

Structural Low Cement Content (LCC) Concrete

An Eco-friendly Alternative for Construction Industry

By

Saif Yousuf

A thesis submitted in partial fulfilment of the requirements for the
Masters of Applied Science degree for Civil Engineering



uOttawa

Department of Civil Engineering
University of Ottawa
Ottawa, Ontario, Canada

© Saif Yousuf, Ottawa, Canada, 2018

ABSTRACT

Pressure is mounting in the construction industry to adopt more environmentally sustainable methods to reduce CO₂ emissions. Portland cement (PC) often constitutes to more than two-thirds of the embodied energy of concrete, and its production generates 5% of global greenhouse gas emissions. One efficient strategy to reduce the cement content without sacrificing performance is the use of particle packing models (PPM) to mix- proportion concrete mixtures with low cement content, the so-called low cement content (LCC) concrete. If on the one hand LCC was seen to be an effective sustainable alternative to the construction industry, its mechanical behaviour, durability and long-term performance are still under debate and thus further research is needed in the area. In this project, continuous PPM theories were used to mix- design structural concrete mixes presenting distinct mechanical properties (i.e. 25 & 35 MPa) and cement contents. Their performance was evaluated in the fresh and hardened states, and gaps, recommendations, and further needs were highlighted. Results show that the use of PPM enables the development of LCC systems, showing impressive hardened state performance (i.e. higher compressive strength and modulus of elasticity and lower electrical resistivity) and low carbon footprint. However, challenges in the fresh state were faced, which may be potentially solved with the use of chemical admixtures, fillers and/or supplementary cementing materials (SCMs).

Keywords: Low cement content (LCC), particular packing models (PPMs), binder efficiency.

Table of Contents

Abstract	ii
Acknowledgements	viii
Chapter 1	1
1.1 Introduction	1
1.2 Objectives and Scope	4
1.3 Thesis Layout	5
Chapter 2	6
2.1 Literature Review	6
2.1.1 Particle packing models (PPMs)	6
2.1.2 Discrete packing model	7
2.1.3 Continuous packing model	13
2.1.4 The role of the packing distribution factor (q)	17
2.1.5 Maximum Paste Thickness (MPT)	18
2.1.6 Rheology of fresh concrete	20
2.1.7 Concrete Workability	22
2.1.8 Consistency (slump test)	23
2.1.9 Mechanical properties of hardened concrete	24
2.1.10 Durability and long-term performance of concrete	28
2.1.11 Sustainability and eco-efficiency in the concrete industry	31
2.2 Gap in the State-of-the-Art	33
Chapter 3	34
3.1 Structural Concrete with lower cement amount using continuous Packing Model: An Eco-Friendly Alternative for Construction Industry	34
3.1.1 Introduction	35
3.1.2 Background: Packing Models	36
3.1.3 Scope And Objectives Of Work	39
3.1.4 Materials And Methods	40
3.1.5 Experimental Results	46
3.1.6 Discussion	56
3.1.7 Conclusions	69
3.1.8 Acknowledgements	69

3.1.9 References	70
Chapter 4.....	74
4.1 Conclusion & recommendations.....	74
4.1.1 Fresh state properties	74
4.1.2 Hardened state properties	75
4.1.3 Optimizing concrete mixture behaviour.....	76
4.1.4 Eco-efficiency of concrete mixtures.....	77
4.1.5 Modelling and forecasting concrete properties	77
4.1.6 Future Works	78
Chapter 5.....	79
5.1 References.....	79

List of Figures

Figure 2.1: Discrete packing model	8
Figure 2.2: Loosening effect	9
Figure 2.3: Wall effect.	10
Figure 2.4: Wedging effect.	10
Figure 2.5: The wall effect at the interface of the aggregate fractions.	11
Figure 2.6: Continuous packing model	15
Figure 2.7: Minimum porosity calculated by the Westman and Hugill modified model according to the distribution modulus, minimum grain of 0.17 μm and maximum of 16 mm.	16
Figure 2.8: (a) Dry packing of particles under uniaxial load, (b) Concrete as a dry packing with cement paste.....	19
Figure 2.9: Rotational rheometer, (1) Rotational device, (2) base reaction and console, (3) elevator, (4) Mortar vessel, (5) mortar impeller.	22
Figure 2.10: Capillary porosity vs. strength relationship obtained in cementitious materials.....	25
Figure 2.11: Influence of the water-to-cement ratio and curing age on concrete strength.	26
Figure 2.12: Arrangement of the flexural test by third-point loading (ASTM C 78).	27
Figure 2.13: Determination of Stiffness Damage Index (SDI: $SI/SI+SII$) and Plastic Deformation Index (PDI: $DI/DI+DII$) from SDT output.	28
Figure 2.14: Concrete resistivity under relative humidity (saturated and unsaturated) and temperature	30
Figure 2.15: Binder intensity (bi_{cs}) vs. 28-day compressive strength for Brazilian (green dots) and international (red dots) data.	32
Figure 3.1: Relation between expected porosity and q-value.....	40
Figure 3.2: Flexural strength test was conducted on UTM of capacity 1000 kN by third point loading at 28 days.....	45
Figure 3.3: Schematic representation and picture of the experimental device used for the measurements of surface resistivity of concrete specimens.....	46
Figure 3.4: Schematic representation and picture of the experimental device used for the measurements of internal resistivity of concrete specimens.....	47
Figure 3.5: Cumulative particle size distributions of the three concrete compositions designed using Alfred continuous PPM, where CPFT = cumulative percentage of particles finer than a specific size.....	48
Figure 3.6: Slump value for 25 MPa concrete mixes.....	49
Figure 3.7: Slump value for 35 MPa concrete mixes.....	50
Figure 3.8: Fresh state density for 25 MPa concrete mixes.....	51
Figure 3.9: Fresh state density for 35 MPa concrete mixes.....	51

Figure 3.10: Compressive strength at distinct ages for 25 MPa concrete mixes.....	52
Figure 3.11: Compressive strength at distinct ages for 35 MPa concrete mixes.....	52
Figure 3.12: Surface resistivity values at distinct ages for 25 MPa concrete mixes.....	53
Figure 3.13: Surface resistivity values at distinct ages for 35 MPa concrete mixes.....	54
Figure 3.14: Internal resistivity values at distinct ages for 25 MPa concrete mixes.....	54
Figure 3.15: Internal resistivity values at distinct ages for 35 MPa concrete mixes.....	55
Figure 3.16: Modulus of Rupture for 25 MPa concrete mixes at 28 days.....	56
Figure 3.17: Modulus of Rupture for 35 MPa concrete mixes at 28 days.....	56
Figure 3.18: Modulus of Elasticity for 25 MPa concrete mixes at 28 days.....	57
Figure 3.19: Modulus of Elasticity for 35 MPa concrete mixes at 28 days.....	57
Figure 3.20: Influence of amount of superplasticizer on the slump value for 35 MPa concrete mix with distribution factor $q: 0.37$	59
Figure 3.21: Concrete as a dry packing with cement paste.....	64
Figure 3.22: Comparison between hardened state properties and MPT for A) 25 MPa and B) 35 MPa concrete mixes.....	65
Figure 3.23: Comparison between binder intensity factor and compressive strength for A) 25 MPa and B) 35 MPa concrete mixes.....	67
Figure 3.24: Modeling the behaviour of concrete as a function of MPT and water-to-cement ratio.....	70

List of Tables

Table 2.1: Comparison of different packing systems (Kumar & Santhanam, 2003).....	17
Table 3.1: Physical and chemical properties of the Portland cement.....	42
Table 3.2: Moisture content and absorption of coarse and fine aggregates.....	42
Table 3.3: Specific gravity for aggregates.....	42
Table 3.4: 25 MPa and 35 MPa mix design and w/c ratio for distinct q factors.....	43
Table 3.5: Global Testing Matrix.....	47

ACKNOWLEDGEMENTS

Firstly, I would like to express my sincere gratitude to my advisor Prof. Dr. Leandro Sanchez for the continuous support of my Master study and related research, for his patience, motivation, and immense knowledge. His guidance helped me throughout the entire project from the research to the Thesis writing. I could not have imagined having a better advisor and mentor for my Master study.

Besides that, I would like to thank Muslim Majeed and Gamal Elnabelsya, for their enormous help in the Structures Laboratory. My sincere thanks to all of my teammates of the Concrete Research Group, especially to Cassandra Trottier, Derick Asirvatham and Sami Shammeh, for their insightful remarks and encouragement, which has broaden my research from various perspectives. Moreover, I would like to give a special thanks for Dr. Vito Santos for all of his help and support to my work. Without him this Thesis could not have become a reality. I would also like to thank Prof. Dr. Beatriz Martin-Perez and Prof. Dr. Elena Dragomirescu for providing me research opportunities (CO-OP) during my undergraduate studies, which encouraged me for doing further research based studies.

I would also like to acknowledge the generous help of Mr. Mohammad Ali Khan from Lafarge Canada Inc. for providing me with the aggregates needed to complete all the laboratory tasks. Thanks to GiaTec for providing me with the SmartBox devices. I would also like to thank Mr. Andre Demers from Natural Resources Canada (CANMET) for his support and help throughout this MASc project.

Finally I would like to thank each of my family members, specially my father Mahmudul Islam and my mother Shakhee Islam for their endless support when I needed. My Masters studies have become possible because of their boundless encouragement and support.

CHAPTER 1

1.1 Introduction

Concrete is one of the most common construction materials used in civil infrastructure worldwide. Its demand is increasing day by day, raising to 400% from the years 1990 to 2002 (Humphreys et al., 2002); (Damineli et al., 2010). Looking back in time, one may notice that concrete-like materials with a number of different cementitious ingredients were used to build ancient civilizations over centuries. Otherwise, the most common cementitious material (also called “binder”) used nowadays to produce modern concrete is portland cement (PC). PC often constitutes to more than two-thirds of the embodied energy of concrete, and its production currently generates more than 5% of global greenhouse gas emissions (Mangulkar & Jamkar, 2013). Moreover, according to Damineli et al. (2010), the need for cement in developing countries are expected to double in the next 40 years, which may result in several environmental issues.

There are various strategies that might be used to decrease the carbon footprint in concrete construction. Maybe the most conventional one currently adopted in practice is the partial PC replacement by residues from other industries, the so-called supplementary cementing materials (SCMs). SCMs such as fly-ash (FA), silica fume (SF) and blast-furnace slag (BFS) have been widely selected in concrete technology to enhance the short and long-term performances of concrete mixtures as well as their eco-efficiency. However, the lack of important global amounts of SCMs along with their current depletion emphasizes the importance of finding other solutions to reduce the negative environmental impact of concrete.

It has been found that increasing binder efficiency (i.e., amount of binder used to develop one unit of material’s property such as compressive strength), or in other words designing low cement content (LCC) systems through the use of advanced particle packing models (PPM) may

correspond to powerful and efficient approaches to lessen concrete carbon footprint (Popovics S. , 1998); (Damineli et al., 2010). PPMs are based on the idea of optimizing the particle size distribution (PSD) or grading of the aggregates skeleton in concrete (Mangulkar & Jamkar, 2013); (Popovics S. , 1998); (Dinger & Funk, 1997); (Damineli et al., 2010). Normally, PPMs are divided in two types: continuous and discrete.

Discrete models can be defined as systems containing two or more discrete particle sizes, in other words, “narrowly defined size classes of particles such as monodisperse, bimodal or even narrow size cuts of multimodal particles” (Brouwers & Radix, 2005). Therefore, in concrete technology applications, discrete approaches refer to the packing of multimodal distributions containing “n” discrete size classes of particles, the so-called “gap-graded” systems. The fundamental assumption of the discrete approach is that each class of particle will pack to its maximum density in the volume available, where the model is classified as binary, ternary or multimodal. Otherwise, continuous PPMs consider continuously sized particles available in the mixture (i.e., no gaps throughout the whole PSD). Moreover, it assumes a similarity condition for particle packing, which means that the array of particles (i.e., “granulation image”) surrounding every particle in the distribution should be similar, regardless the size of the particle (Mangulkar & Jamkar, 2013). The latter approach is considered compelling in concrete technology since most of the concrete components, at least in theory and for mixtures designed for conventional applications, might be treated as continuous PSDs. Either discrete or continuous, PPMs can lead to a significant reduction in the binder content (Fuller & Thompson, 1907); (Brouwers & Radix, 2005).

Usually, conventional mix- design approaches (e.g., ACI method) used in the construction industry adopt empirical techniques and assumptions to proportion the distinct ingredients, which often results in the non-efficient use of PC (i.e., high amounts of cement used to obtain only moderate

strengths). It is well established that the mechanical properties of concrete are primarily related to its porosity, which is proportional to the water-to-cement ratio of the mix (i.e. high w/c ratios provide high porosity in the material). Therefore, no theoretical correlation between “mechanical properties” and “cement consumption” is found in the literature, especially in the design of conventional mixtures (e.g. 20-45 MPa), which supports the use of LCC. However, there are still some doubts on the performance of LCC mixes in the fresh (i.e. consistency, rheological behaviour, etc.) and hardened states (i.e. mechanical properties, stiffness, etc.) along with durability and long-term behavior, which prevents its current use for important applications (i.e. structural applications) and highlights the need of further research in the area.

1.2 Objectives and Scope

The current project presents two distinct yet interconnected objectives: 1) to evaluate the fresh and hardened state behaviours of concrete mixtures with reduced cement content, the so-called low cement content (LCC) concrete towards a greener and more sustainable future in the construction industry, and 2) to introduce, discuss and appraise the use of *continuous particle packing models* (PPMs) to mix- design structural conventional concrete mixtures with reduced cement content.

PPMs application in civil engineering is relatively new and thus an in-depth experimental campaign was performed throughout the project to understand its influence on a number of different properties of concrete. It is worth noting that in this project LCC concrete is defined as a concrete mixture presenting an amount of cement lower than the minimum required in North America for harsh climates and flat works according to ACI 302 (i.e. 335 kg/m³).

In this project, conventional concrete mixes (i.e. 25 and 35 MPa) with different cement contents were designed with the use of conventional (i.e. absolute volume method – ACI method) and continuous PPMs (i.e. Alfred model). A number of experimental test procedures were conducted at the laboratory in the fresh (i.e. slump test, density and air content) and hardened states (i.e. compressive strength, bending flexure, modulus of elasticity, stiffness damage test, surface electrical resistivity, etc.), and analysis and recommendations on the use of PPMs and LCC for structural applications were performed.

1.3 Thesis Layout

This MASc thesis presents and analyses the results of a comprehensive laboratory campaign on the use of particle packing models (PPMs) to mix- design concrete mixtures with reduced cement content. The main objective of this work is to perform an in-depth evaluation of the fresh (i.e. consistency, density, etc.) and hardened state (i.e. compressive and tensile strength, modulus of elasticity and overall quality) properties of conventional and low cement content (LCC) concrete mixtures designed with conventional and PPMs.

This document is divided into a number of sections, with the core of the document corresponding to the scientific paper covering the specific objectives of the current research. In order to make the content of this paper-based MASc thesis clearer to readers, Chapter 1 is first presented with the aim of efficiently introducing the global context of the study, followed by the description of the main objectives and scope of the work. A brief literature review of the current state-of knowledge on PPMs and LCC is then presented (Chapter 2). The following section (Chapter 3) describes in details an extended version of the scientific paper produced throughout this Thesis. Finally, based on the results obtained in this study, a series of conclusions and recommendations were prepared and presented in section 4 of this document.

It is worth noting that a journal version of the scientific paper presented in Chapter 3 was already submitted to Journal of Building Engineering (Elsevier) and is currently under review.

CHAPTER 2

2.1 Literature Review

2.1.1 Particle packing models (PPMs)

Recently, the interest in particle packing theories has increased in distinct sectors of engineering. This is happening because natural and/or industrial granular materials currently being used contain a number of particles of different sizes and shapes. Examples of granular particles are aggregate particles (i.e. coarse and fine), minerals, metals and/or chemical powders, soil, etc. The physicochemical behaviour presented by these materials is thus dependent not only on the interactions between their components but also on their particular properties (Stroeven & Stroeven, 1999).

Flowability of concentrated suspensions such as mortar and/or concrete also depends on physicochemical parameters. Particle size distribution (PSD), for instance, promotes higher or lower packing density and defines, in the presence of water, the rheological behaviour of suspensions. Moreover, distinct characteristics, such as mechanical strength, elastic modulus, bleeding, creep, shrinkage, and durability related properties, can also be improved through the use of better packing densities and thus superior concrete performance might be achieved through particle packing (De Larrard & Sedran, 1994).

Particle packing concepts are based on the selection of the size and proportion of granular materials and thus larger voids are filled by smaller particles, whose voids will then be filled by even smaller particles in a continuous process (Oliveira et al., 2000).

Since the first paper written on particle packing in concrete (Féret in 1892), several particle packing models (PPMs) were proposed as tools for calculating the particle packing density (PPD) of

granular materials, and thereby for optimizing the so-called aggregates skeleton of concrete mixtures (Goltermann et al., 1997).

There are two basic approaches in the use of PPMs: *discrete* and *continuous* models. The differences of these two will be further discussed in the following sections. It is worth noting that the most common discrete and continuous PPMs (Furnas and Alfred models, respectively) were actually studied and were seen to converge on a unique equation (Equation 2.1). The latter shows that, in fact the two distinct approaches using Furnas (discrete) and the Alfred (continuous) models can be considered as two different ways of expressing the same thing.

$$CPFT(\%) = 100 \left(\frac{D^q - D_S^q}{D_L^q - D_S^q} \right) \quad (2.1)$$

where CPFT is the volumetric percentage of particles smaller than the diameter D, D_L is the diameter of the largest particle, D_S is the diameter of the smallest particle, and q is the distribution factor.

2.1.2 Discrete packing model

Discrete packing approaches could be described as packing of multimodal distributions containing two or more discrete particle sizes. In discrete methods, the coarse particles are first densely packed, forming the structure within which the smaller particles are subsequently introduced. In three-component packing, the midsized particles are packed into the pores formed by the coarse particles, and the smaller particles are packed into the pores formed by the midsized particles up to the highest packing density (Dinger & Funk, 1997). Discrete PPMs are often considered as “gap-graded” systems. Figure 2.1 shows discontinuous grading of a discrete PPM.

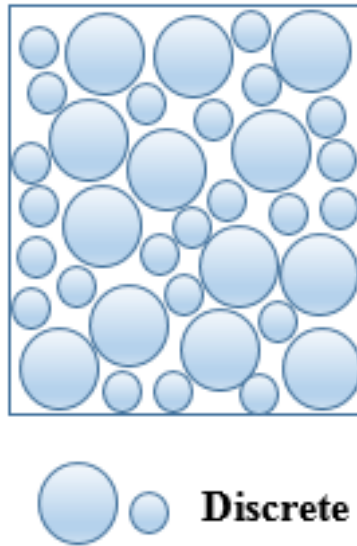

Figure 2.1: Discrete packing model

Furnas's name is the one that comes up first while talking on discrete PPM. The equations prescribing the packing density of granular suspensions were first introduced by Furnas in 1929 (Fennis & Walraven, 2012). To consider an ideal packing model, Furnas had taken into consideration a mixture of two materials only including fine and coarse fraction particles (binary or bi-modal mixture). For the fine fraction, Furnas considered the diameter (d_1), volume fraction (y_1), and packing density (ϕ_1). On the other hand, for the coarse fraction the author considered the diameter (d_2), volume fraction (y_2) and the packing density (ϕ_2). Furnas described two distinct cases which were dependent on the volume fraction of the fine and coarse elements of the mix, known as fine grain and coarse grain dominant, respectively. According to Furnas, a mix could be called "fine grain dominant" whenever the volume fraction of small particles is present in larger amounts (i.e. $y_1 > y_2$). On the other hand, a coarse grain dominant mix would take place when the volume fraction of coarse particles is present in larger amounts (i.e. $y_1 < y_2$). Due to the particle size distribution, the voids between the larger particles can be filled by the smaller particles. However, to validate Furnas model, the condition $d_1 \ll d_2$ must be fulfilled; otherwise the diameter

ratio d_1/d_2 should also influence the packing density of the binary mixtures (Kumar & Santhanam, 2003). The reason for this are: (1) the smaller particles may be too large to be situated within the interstices of the larger particles, and (2) the packing of smaller particles along the surface of a larger particle gives a lower packing density than in the bulk of the binary packing due to the wall effect.

Particle packing can be affected by both structural and interaction effects. Westman and Hugill recognized the existence of geometrical particle interaction, without taking into account this interaction between particle groups, when developing their algorithm in 1930. However, in 1931, Furnas published a paper where the author showed the effect of geometrical interaction between two different size classes on the maximum packing density (Fennis & Walraven, 2012).

There are three main interaction effects: loosening, wall and wedging effects. When a fine particle is embedded into a granular matrix of coarse particles and it is too large to fit in a void between the coarse aggregates ($d_1 \approx d_2$), it disturbs the overall packing density of the granular coarse particles. The latter is called loosening effect, and it increases the void ratio of the aggregates skeleton (Figure 2.2).

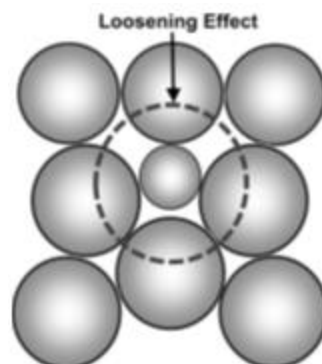

Figure 2.2: Loosening effect (Mehdipour & Khayat, 2017)

“Wall effect” happens whenever the dominant fine particle packing is “retained” by the boundaries of coarse particles, causing further voids to be formed around the coarse aggregate particle (Figure 2.3). For those fine particles, the surface of coarse aggregates particles seems to be a “wall” due to their size difference, and that is why this phenomenon is called wall effect.

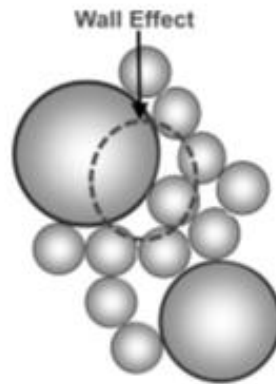

Figure 2.3: Wall effect (Mehdipour & Khayat, 2017).

Similar to the first two effects, “wedging effects” can also decrease the particle packing density. The wedging effect occurs whenever fine particles are not sufficiently fine to fill the voids among the coarse particles (Figure 2.4). For angular particles, the wedging effect is more prevailing, in comparison to spherical particles (Kwan, 2015).

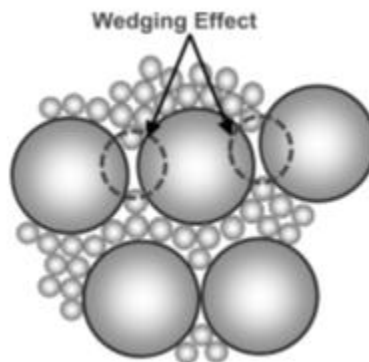

Figure 2.4: Wedging effect (Mehdipour & Khayat, 2017).

Powers (1968), in his studies on particle packing, considered the impact of loosening effect. He proposed an expression to get the minimum void ratio of binary mixtures. Aim and Goff (1967) also introduced a simple geometrical binary model, including the explanation on the higher porosity observed experimentally in the interfacial transition zone (ITZ) of larger particles (Figure 2.5), addressing the wall effect (Kumar & Santhanam, 2003). They suggested that a correction factor should be used on particle packing calculations of binary mixtures accounting for that effect.

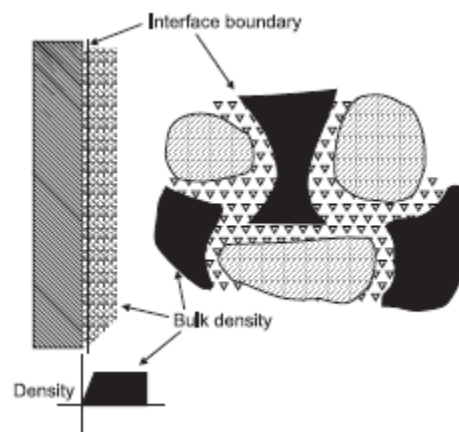

Figure 2.5: The wall effect at the interface of the aggregate fractions (Kumar & Santhanam, 2003).

Toufar et al. (1977) proposed a model aiming to calculate the packing density of multicomponent mixtures, based on the weighted average of the total number of binary mixtures for diameter ratios (d_1/d_2) between 0.22 and 1. The fundamental concept of the model is that the smaller particles (diameter ratio slightly above 0.22) should be too large to fit in the space between larger particles. For ternary mixtures with very small diameter ratios (such as in concrete) the binary mixture of coarse and fine aggregates, without cement in the interstices, is not realistic from a physical point of view, and it must result in extremely low packing density. However, the author found a way to at least partially solve this issue: based only on two larger particles, to calculate the binary packing

density and the average particle size. Then, to use the values obtained to recalculate the binary packing system with the finer components. This resulting packing density then would represent the ternary packing density of the system.

A modified Toufar model was proposed by Goltermann et al. (1997) for multi-component aggregate blends, and two new parameters were developed (“*eigenpacking*” degree and characteristic diameter of aggregate) to compensate the deviations from the assumptions of monosized and perfectly spherical particles. For ternary blends, the authors suggested blending two fractions with the highest particle size ratio, and then combining it with the third fraction.

De Larrard & Belloc (1997) proposed distinct models based on multi-component mixtures. Firstly, aiming to optimize the granular skeleton, Stovall, de Larrard and Buil developed the *Linear Packing Density Model* (LPDM), involving the wall effect in the “dominant fine grains” field and the loosening effect in the “dominant coarse grains” field (Stovall et al., 1986). Next, the Solid Suspension Model (SSM) was proposed after some modification in the LPDM, bringing the idea of a virtual packing density, which represent the maximum packing density achievable with a given mixture, by keeping each particle in its original shape and placed one by one of a mixture (De Larrard & Sedran, 1994). An important concept introduced in this model is β , which is the maximum packing density achievable within a given granular mixture. Afterwards, a new discrete model, the so-called *Compressible Packing Model* (CPM), was proposed by De Larrard in 1999, assuming that the packing density also depends on the mixture compaction (compaction index). Hence, the index K was introduced to calculate the value from a virtual packing density (β) to an actual packing density (ϕ); and also two new concepts were defined to characterise the mixtures: filling diagram and segregation potential (Kumar & Santhanam, 2003).

More recently, Roquier (2016) introduced a new version of the CPM, so-called the 4-parameter CPM to predict the packing density of bidisperse spherical particles. This model incorporates the loosening effect, the wall effect, the compaction index, and the critical cavity-size ratio. The critical cavity-size ratio indicates whether a fine particle can fit inside a small cavity without disturbing the overall skeleton of larger particles.

2.1.3 Continuous packing model

In continuous PPM, it is assumed that all possible particle sizes are present in the PSD. In other words, there is no “gap” between size classes, with subsequent size class ratios close to 1:1. The first continuous PPM was brought by Fuller and Thompson in 1907 (Equation 2.2). In the “Fuller Thomson model”, the “ideal” grading curve is the one that maximizes packing density.

$$CPFT = \left(\frac{d}{D}\right)^n \times 100 \quad (2.2)$$

where CPFT is the cumulative percentage finer than d, D is the maximum particle size, d the given particle size, and n was found to be optimal at 0.5. However, n was recently changed to 0.45 (Kumar & Santhanam, 2003).

In 1998, Fuller’s “ideal” curve was modified by Shakhmenko & Birsh (1998) for concrete mixture proportioning. They mentioned that the exponential factor (n) on Fuller’s curve depends on the shape of the particles (i.e. angular vs. round). They also found that Fuller’s curve works well with dry concrete mixtures. However, the amount of sand might be increased for more flowable and pumpable mixtures or whenever it is required a slump greater than 50 mm (Shakhmenko & Birsh, 1998). It was also suggested that depending on the consistency of the concrete and types of aggregate, the Fuller’s ideal curve should be modified, according to Equation 2.3.

$$CPFT = T_n(d_i - d_0)^n \quad (2.3)$$

where n is the ideal exponential factor of the grading curve, d_i is the particle size, d_0 is the minimum particle size of the distribution, T_n is a coefficient which depends on the maximum size and shape of the aggregates.

In 1930, Andreassen followed some of the previous PPMs discussed above, especially Fuller Thompsons' model to develop his work on particle packing. After some experimental and modeling testing, the author proposed an "ideal" packing packing curve (Equation 2.4), where it was assumed that the smallest particle would be infinitesimally small.

$$CPFT = \left(\frac{d^q}{D}\right) \times 100 \quad (2.4)$$

where CPFT is the cumulative percentage finer than d , d is the given particle size, D is the maximum particle size, and q is the distribution factor.

Dinger and Funk (1997) worked on Andreassen's equation and modified accordingly, as they recognized that in real life the finest particles of a given material are not infinitesimally small but are finite in size. As a result, a revised model was developed which linked Andreassen and Furnas distributions, the so-called AFDZ (Andreassen, Funk, Dinger, and Zheng) or Alfred model (Equation 2.5).

$$CPFT = \left(\frac{d-d_0}{D-d_0}\right)^q \times 100 \quad (2.5)$$

where CPFT is the cumulative percent finer than d , d is the given particle size, d_0 is the minimum particle size, D is the maximum particle size, and q is the distribution factor.

Depending on the rheological features required for a concrete mixture, the q values in Alfred's equation may vary from 0.21 to 0.37, with factors closer to 0.21 for high flowable concrete (i.e. self-consolidating concrete, SCC) and 0.37 for roller compacted concrete (RCC). Hence conventional vibrated concrete mixtures would be in between these extreme q values (Kumar & Santhanam, 2003).

Figure 2.6 illustrates a continuous PPM with the presence of various particle sizes. It is worth noting that continuous PPMs are based on assumptions of perfect spheres, smooth particle surfaces and no attracting or repelling forces between particles, which do not necessarily happen in reality. Furthermore, some of the parameters that are not considered in the Alfred model can indeed change the packing density of concrete mixtures such as morphology (i.e. shape and texture), porosity (i.e. within the aggregate particles and cement paste), interaction effects (i.e. loosening, wall and wedging effects) and different compacting techniques.

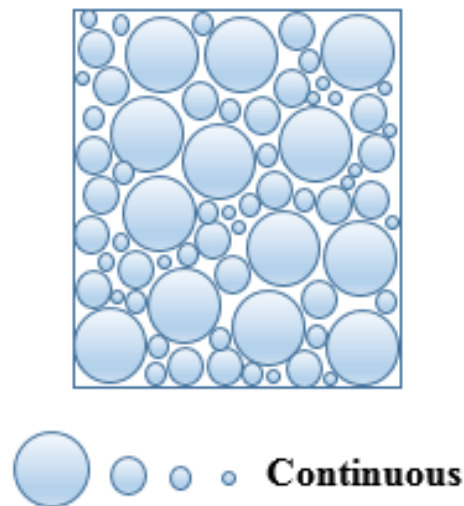

Figure 2.6: Continuous packing model

According to Fruhstofer and Aneziris (Fruhstofer & Aneziris, 2014), as well as Alfred and Zinger (Fennis & Walraven, 2012), the highest packing density can be achieved with a q factor equal to

0.37, which would likely bring benefits to the short and long term hardened state performance of concrete mixtures along with an increase in binder efficiency. However, it should be considered that highly packed mixtures may bring some limitations in flowability, thus not being suitable for all concrete mixtures, depending on the application.

In 1994, Funk and Dinger worked on the previous Westman and Hugill model, and proved theoretically and experimentally that the lowest porosity is achieved with a q factor of 0.37. Moreover, they found that the porosity of a given granular system suddenly raises whether a greater q factor is used, yet the same trend was not observed for q values lower than 0.37 (Figure 2.7).

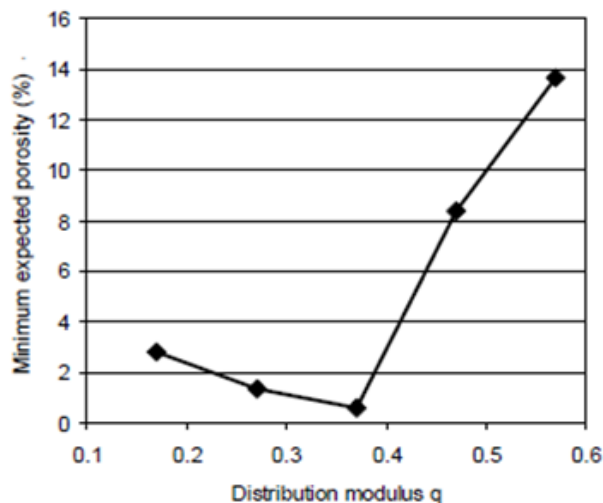

Figure 2.7: Minimum porosity calculated by the Westman and Hugill modified model according to the distribution modulus, minimum grain of 0.17 μm and maximum of 16 mm (Funk and Dinger, 1994).

Table 2.1 summarizes the different PPM approaches previously described, comparing not only the type of packing system but also the interaction effects considered in each of them.

Table 2.1: Comparison of different packing systems (Kumar & Santhanam, 2003).

Year	Models	Packing system			Effect on packing		
		Binary	Ternary	Multi-modal	Wall effect	Loosening effect	Compaction effect
Discrete approach							
1	1929	Furnas	X				
2	1967	Aim & Goff	X				
3	1969	Powers	X			X	
4	1977	Toufar, Klose & Born	X	X		X	
5	1986	LPDM			X	X	
6	1994	SSM			X	X	
7	1997	Modified Toufar			X		X
8	1999	CPM			X	X	X
9	2000	Modified LPDM			X	X	X
Continuous approach							
1	1907	Fuller & Thomson		X			
2	1930	Andreassen		X			
3	1997	Modified Andreassen		X			

2.1.4 The role of the packing distribution factor (q)

In a continuous packing model, such as the Alfred model, the packing distribution factor q represents the fraction portion of the fine and coarse particles. The higher the q value, the higher the coarse fraction in the mix. Changes in q values directly interfere with the particles' interaction. Lower q values correspond to a rise in the proportion of fine materials in the PSD, which provides a higher amount of matrix (e.g. cement paste) among the coarse aggregates. If $q < 0.30$, the mixture may likely present interesting flowability, which enables the production of well-compacted concretes. If this value is even lower ($q < 0.25$), it is possible to design self-consolidating concrete (Castro & Ferreira, 2016).

The use of packing systems may also result in a significant reduction of voids. Therefore, smaller amount of matrix (cement paste) is required for the same flow and thus lower amount of water is needed to reach the required water-to-cement ratio (Damieneli et al., 2017). Once the concrete strength is directly related to water-to-cement ratio, the mechanical properties may be increased. In addition, the desired strength can be achieved with a reduced volume of paste, which means an

increase of binder efficiency (Damieneli et al., 2017) and may result in improvements on the durability-related properties of the concrete, since the material gets more packed and denser, due to the porosity reduction. Finally, since portland cement production is responsible for high CO₂ emissions, and PC is by far the most expensive ingredient in the system, the use of an optimized amount of cement is one of the most eco-friendly and cost-effective ways to design concrete (Damieneli et al., 2017).

2.1.5 Maximum Paste Thickness (MPT)

The flowability of concrete can be increased when the distance between coarse particles (diameter > 100 µm) become higher than a minimum critical value. Since the space between coarse particles relies on the cement paste volume and, consequently, the amount of fine particles, concrete flow will be greatly influenced by the PPM selected on the mix- design.

The maximum paste thickness (MPT) represents on “average” the maximum distance between aggregate particles greater than 100 µm and can be a useful tool for the assessment of PPMs. MPT considers that part of the cement paste is responsible for coating the coarse grain surfaces, whereas another important portion fills the voids among them, and lastly, the fraction in excess accomplishes the separation of the aggregates particles (Bonadia et al., 1999).

If on the one hand the w/c ratio has been widely used as a tool for forecasting the compressive strength of concrete mixtures, the MPT might be suitable for assessing more precisely the mechanical properties differences between mixtures with distinct packing densities and same water to cement ratios (de Larrard & Belloc, 1997).

In a dry packing of particles under compression, the coarse particles tend to be submitted to maximum stresses, as they act as “hard points” in a soft medium constituted by smaller particles

(Figure 2.8a). However, a completely different scenario is observed when the same system is filled with cement paste in higher volume than the packing porosity (Figure 2.8b). The cement paste will then take place between close aggregates particles, and thus provide some flow to the mix. The distance between these aggregates is defined as the maximum paste thickness (MPT) (de Larrard & Belloc, 1997).

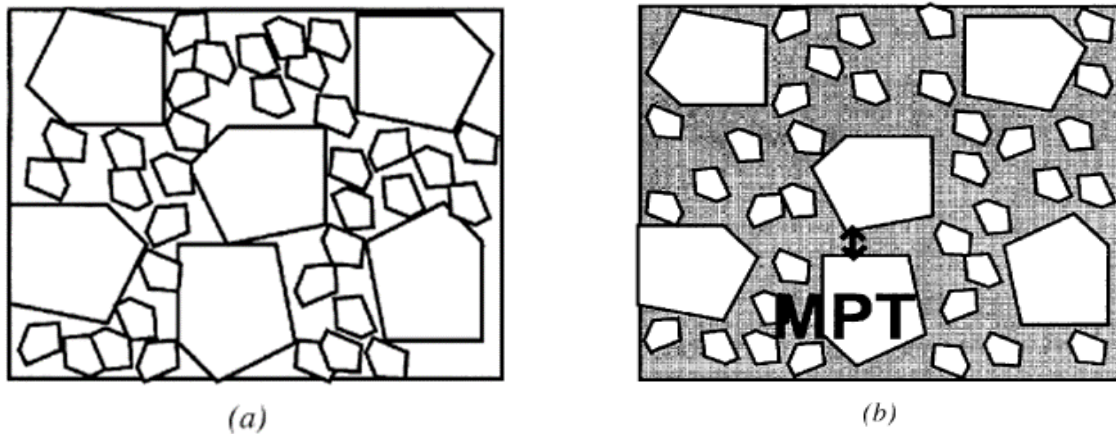

Figure 2.8: (a) Dry packing of particles under uniaxial load, (b) Concrete as a dry packing with cement paste (de Larrard & Belloc, 1997).

De Larrard & Belloc (1997) defined MPT as

$$\text{MPT} = D_{\max} \left(\sqrt[3]{\frac{g^*}{g}} - 1 \right) \quad (2.6)$$

where D_{\max} is the maximum aggregate size, g is the aggregate volume in a unit volume of concrete, which can be easily derived from the mixture proportioning, and g^* can calculate by means of Equation 2.7,

$$g^* = 1 - 0.47 \sqrt[5]{\frac{D_{\min}}{D_{\max}}} \quad (2.7)$$

where D_{\min} is the minimum sized aggregate corresponding to 10% passing, and D_{\max} is the maximum sized aggregate corresponding to 90% passing.

De Larrard & Belloc (1997) compared the compressive strength developments of cement pastes and composite materials (i.e. mortar and concrete) with different aggregate types and amounts. It was found that the strength of the cement paste is always higher compared to composite materials such as concrete, even though the stiffness is higher for composite. Moreover, the author found that the strength in composite materials decreases when the maximum sized aggregate (MSA) and the MPT increase, at a given age and for a given type of aggregate.

2.1.6 Rheology of fresh concrete

Rheology is the science of flow and deformation of materials. Deformation and flow are referred to as strain or strain rate, respectively, and indicate the distance over which a body moves under the influence of external forces or stress. For this reason, rheology is used to study fundamental relations, the so-called constitutive relations between loads and deformation of materials.

Rheology, as a science of flow, studies the behaviour of fluids, such as liquids, suspensions, slurries, and emulsions. In a fluid, the presence of solid particles interferes on its flux lines, increasing the viscosity and deviating its behaviour from a conventional *Newtonian fluid* such as water. *Non-Newtonian* fluids, such as the ones used in civil engineering, behave in a wide variety of ways or can even present sometimes unpredictable behaviour.

In fresh state, cement paste, mortar and concrete can be considered *Non-Newtonian* fluids and thus different behaviours might be expected as a function of their mix- proportioning and ingredients. The influence of PSD on the rheological properties of suspensions relies on the size of the particles. Two groups of forces from distinct natures can be identified in granular systems: A) “*Surface Forces*” acting in the presence of small particles with high specific surface areas, and B) “*Gravitational Forces*,” for large particles with smaller specific surface area. The smaller the particle, the lower the effect of gravitational forces and the higher the effect of surface forces, i.e.,

physicochemical attraction and repulsion. Therefore, in suspensions composed by wide PSD, both groups of forces will be acting. It is worth noting that high PDS are often found in most concrete mixtures, with particles sizes varying from 1 μm to $> 20 \text{ mm}$, where the large particles represent the aggregates, which are embedded into a matrix of smaller particles (Oliveira et al., 2000).

In a system of crowded particles, flowability is produced by the mobility proportioned by the fluid linking the solid particles. Thus, first of all, the liquid needs to fill the voids between the particles, and then it needs to cover all of their surface area. After these first two steps, the fluid starts detaching the various particles, separating and allowing them to move independently (Damineli et al., 2013). The higher the distance, the easier the movement. When the voids between particles are high, the fluid content required for allowing the overall flow is higher. Hence, it is crucial to consider the behaviour of the cement paste, the forces acting on the aggregates and the interaction between cement paste and aggregates to understand the relationship between PSD and flow.

It is well established in civil engineering that rheology is the science able to fully characterize the overall behaviour of crowded suspensions such as concrete in the fresh state. The efforts related to the mixing process of concrete and, therefore, its rheological parameters can be measured by rotational rheometers (Figure 2.9) capable of dealing with intense torques produced during the mixing process (Franca et al., 2016). The resulting rheometry data reflects the flowability of mixes under distinct torque conditions and can be extremely valuable to classify concrete behaviours for a number of field application (e.g., self-compacting, pumped, shotcrete, vibrated, etc.) (Santos et al., 2009). However, due to its high cost and non-trivial character, rheology is often left aside and easier, cheaper and more straightforward test procedures are normally selected to assess concrete in the fresh state. Although incomplete, these straightforward methods are able to identify some of

the rheological properties of concrete and, when used in a correct way, are thus able to answer some specific questions on the fresh state behaviour of the material.

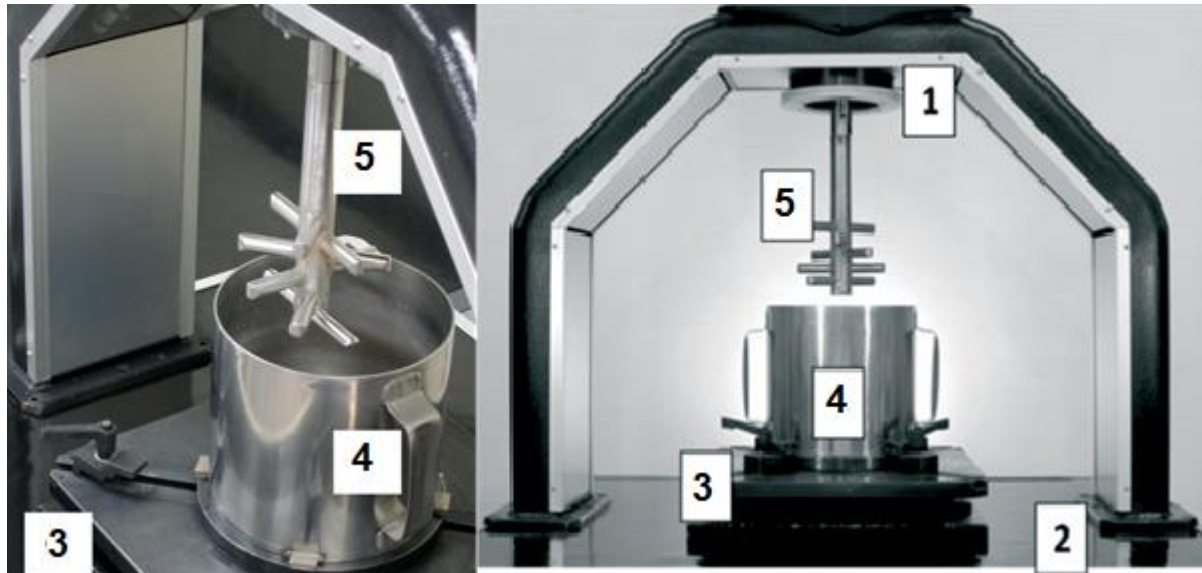

Figure 2.9: Rotational rheometer, (1) Rotational device, (2) base reaction and console, (3) elevator, (4) Mortar vessel, (5) mortar impeller (Franca, 2016).

2.1.7 Concrete Workability

Workability is a qualitative concept of concrete that describes the ease and homogeneity with which it can be mixed, transported, compacted and finished, without exhibiting excessive bleeding and/or segregation (Ramachandran & Feldman, 1995). Thus, workability includes properties such as flowability, moldability, cohesiveness, compatibility and finishing.

A number of factors may affect the workability of concrete mixtures such as the cement paste and aggregate contents, viscosity of the cement paste, maximum size, PSD, texture and shape of the aggregates.

Workability always depends on the application. Flowable mixtures may be considered quite workable for self-consolidating concrete (SCC), whereas they would have been considered not workable to be compacted with roller compacted concrete (RCC) techniques in the field. Rheometry through the use of rheometers would be very likely the procedure capable of quantifying the workability and full rheological behaviour of concrete mixtures. Yet, they are not that often used in practice due to the reasons previously described (Pileggi et al., 2000).

Several “simple” methods have been suggested to determine concrete workability, but none showed to be capable of measuring this qualitative property directly. As a result, various straightforward test procedures currently used in the market are selected for measuring “indices” of workability, such as consistency through the use of slump tests. Other methods could also be used to indirectly measure aspects of workability such as the *Compacting Factor*, *Ball Penetration* and the *Vebe Tests*. Even though all the prior procedures might be used to appraise indices of concrete workability, they actually measure different fresh state properties and thus cannot be compared to each other. Hence, it is very important to understand what is measured through these distinct test methods to avoid misinterpretation and improper use of their outcomes.

2.1.8 Consistency (slump test)

The slump test is one of the most common tests conducted around the world for fresh concrete. It is a widespread practice that the slump test is performed on the site before concrete’s acceptance to understand some aspects of “workability” of the material (Neville, 2011). However, it is well established that slump is a “single-point” test and thus can only describe a portion of the concrete fresh state behaviour, the so-called consistency (Struble & Ji, 2001).

Consistency of a concrete is the ease with which the material flows under its own weight, being an important component, yet not fully describing the materials’ workability since mixtures with

the same consistency may present distinct workability depending on the application (Struble & Ji, 2001).

Chemical admixtures such as water reducers presenting different ranges (i.e. low range, middle range or high range, the so-called superplasticizers) may be used to change the viscosity and thus the consistency of concrete mixtures in the fresh state. The effects of superplasticizer admixtures (SP) on the cement hydration as well as on the microstructure and morphology of hardened cement paste have been widely reported in the literature (Ramachandran & Feldman, 1995). Yet, it is well established that besides the consistency, the use of SP in concrete influences its overall flow, decreases the water requirements for the same consistency and may change setting time (Castro et al., 2009; Castro et al., 2011; Oliveira et al., 2018).

2.1.9 Mechanical properties of hardened concrete

In conventional concrete design and quality control, compressive strength is the property generally specified. The main reason is that besides being a structural material requiring minimum mechanical performance, evaluations of mechanical properties such as compressive and tensile strengths are often less expensive and relatively straightforward when compared to other physicochemical parameters. Furthermore, various properties of concrete, such as permeability, resistivity, elastic modulus, along with some durability-related properties, are believed to be dependent on strength and may consequently be deduced from strength results.

Compressive strength is the fundamental property of ceramic-like materials such as concrete. Due to its porous nature (starting from their ionic/covalent chemical bonds), concrete behaves quite well under compressive stresses and presents an inferior behaviour under tensile stresses of about 10% of its performance in compression for sound materials (Mehta & Monteiro, 2005).

In general, there exists a fundamental inverse relationship between capillary porosity (composed by major pores) and compressive strength of concrete. The lower the capillary porosity, the greater the compressive strength. Yet, this relationship is not linear and convex trend as by Figure 2.10.

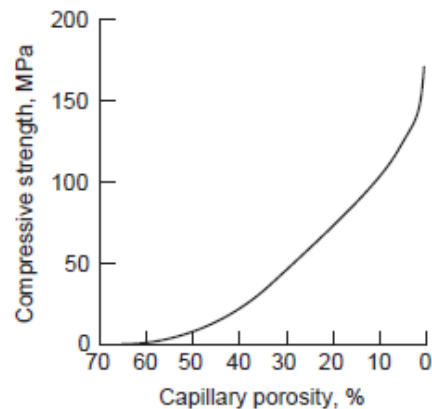

Figure 2.10: Capillary porosity vs. strength relationship obtained in cementitious materials (Mehta, 2005).

While the overall porosity of hardened cement pastes can be directly related to their strength, with concrete the situation is not as straightforward. The presence of coarse and fine aggregates as well as interfacial transition zones (ITZs) between the aggregates and the cement paste makes predictions of strength based upon strength vs. porosity relationships less precise. Yet, the concept of strength vs. porosity relationship must still be followed since porosities found in all component phases of concrete, including ITZs and aggregates, indeed become a limiting strength factor. However, in concrete, the compressive strength of the material should rely on both the strength of the matrix (i.e. mortar) and the ITZ (Mehta & Monteiro, 2005).

Duff Abrams (1924) developed maybe the most widespread relationship regarding the compressive strength of conventional concrete. This relationship accounts for the quality of both concrete matrix and ITZ through the use of the water-to-cement ratio parameter. The higher the

w/c ratio, the higher the porosity of the cement paste, matrix and ITZ, resulting in a weaker overall material (Figure 2.11).

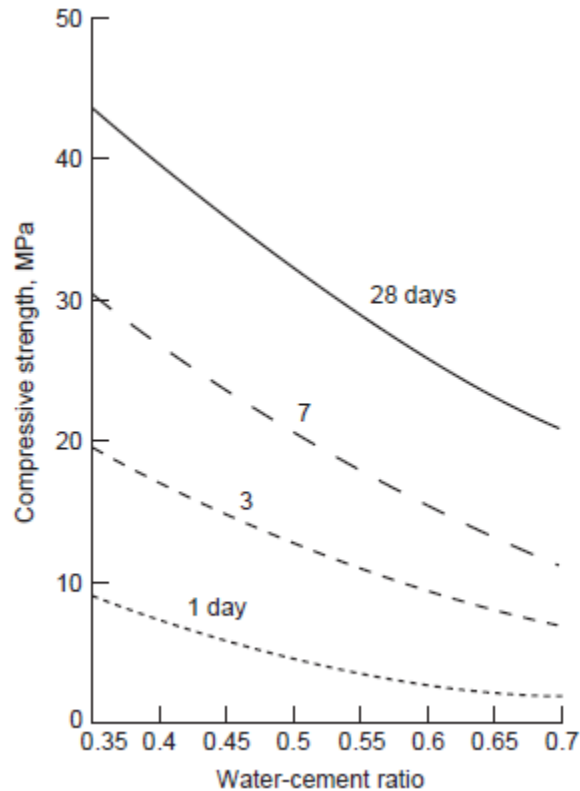

Figure 2.11: Influence of the water-to-cement ratio and curing age on concrete strength (Mehta, 2005).

Tensile strength of porous cementitious materials is barely measured because of the poor performance of these materials under tension. Yet, there are some structures and structural components made by cementitious materials in which the tensile strength is an important parameter, such as pavement, slabs on ground, etc. Otherwise, it is well established in fracture mechanics that the tensile strength is the most important feature controlling cracking formation/spreading in cementitious materials, which may bring an interest on its evaluation. Moreover, it has been found that the granular skeleton might influence cracks initiation/spreading

through the so-called “arrest mechanisms” often found in concrete. Thus, it is anticipated that PPMs might directly influence the behaviour of cementitious materials under compressive and especially tensile stresses (Santana Rangel et al., 2017; Castro & Ferreira, 2016; Zuo et al., 2018). One of the most commonly used tests for estimating “indirectly” the tensile strength of concrete is through ASTM C 78 - third-point flexural loading test (Figure 2.12). Although not a “direct” nor “pure” measure of the tensile strength, the third point flexural test provides an indication of the behaviour of cementitious materials under bending which could be directly correlated to their practical response in the field.

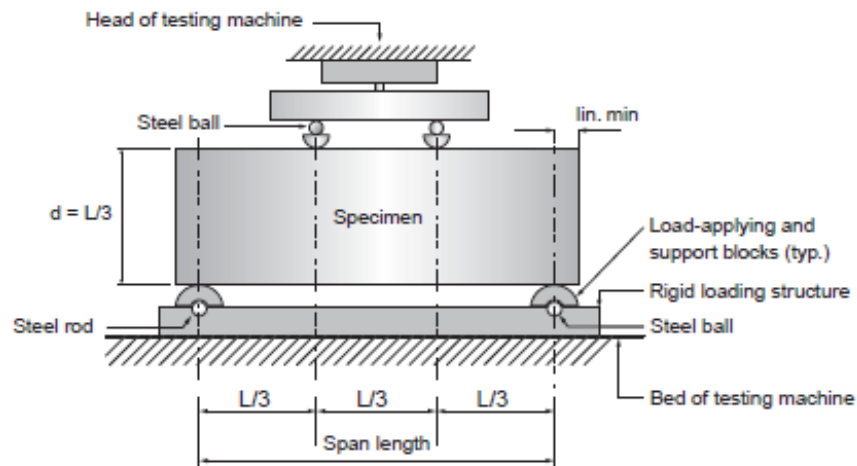

Figure 2.12: Arrangement of the flexural test by third-point loading (ASTM C 78).

Recently, Sanchez et al. (2012) proposed the use of the Stiffness Damage Test (SDT) to quantify the degree of damage in concrete affected by a number of distress mechanisms such as alkali-aggregate reaction (AAR), freezing and thawing (FT) and delayed ettringite formation (DEF). The SDT is a cyclic test procedure in compression usually performed at 40% of the design (28-day) concrete strength of the sample under analysis. The main outcomes of the test are: 1) the modulus of elasticity (calculated as the average of the modulus obtained in cycles 2 and 3) as well as the 2)

Stiffness Damage Index (SDI) and 3) Plastic Deformation Index (PDI), which are respectively the ratio between the dissipated energy (SI) or plastic deformation (DI) placed over the five loading/unloading cycles and the total energy (i.e. SI + SII) or deformation (DI + DII) obtained over the five cycles (Sanchez et al., 2016) (Figure 2.13).

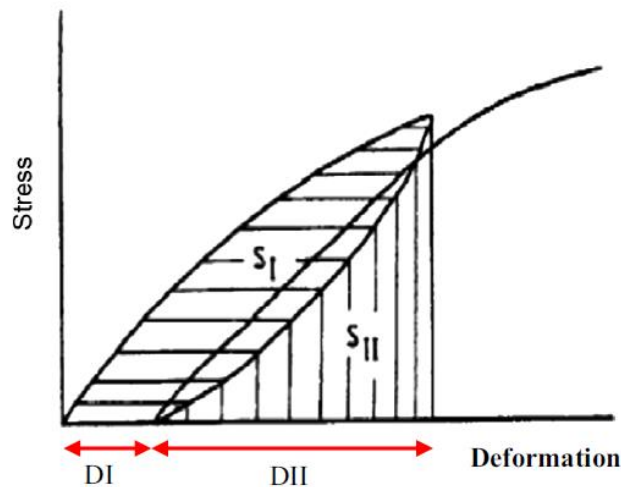

Figure 2.13: Determination of Stiffness Damage Index (SDI: S_I/S_I+S_{II}) and Plastic Deformation Index (PDI: $DI/DI+D_{II}$) from SDT output (Sanchez et al., 2016).

Although the SDT has been used so far to detect damage in affected and distressed concrete, it is also expected to be a promising tool to appraise the overall quality of cementitious materials and the likely influence on the hardened state properties by the quality/arrangement of the aggregate's skeleton.

2.1.10 Durability and long-term performance of concrete

Durability is usually related to the long-term performance of a material in service. For conventional PC concrete, durability can be defined as its ability to resist weathering action, chemical attack, abrasion, or any other physical and or chemical process of deterioration (ACI Committee 201). In other words, concrete will be durable if it can keep its original performance when exposed to its service environment.

Normally, to assess the behaviour of conventional PC concrete against a given mechanism of damage, concrete samples are cast and placed in environments enabling the development of the mechanism under evaluation. This is the case of the most common distress mechanisms such as freezing and thawing, alkali-aggregate reaction, sulfate attack (internal and or external), etc. However, although very precise, most of those test procedures are time-consuming and expensive to perform and thus some fast alternatives were proposed. One of those alternatives was the use of non-destructive techniques (NDT) such as electrical resistivity (ER).

ER has been widely used by researchers to appraise the overall quality and ability of a material to resist against different durability-related problems (Morris et al., 2002). However, caution should be taken on the test results since it is strongly influenced by the temperature and humidity of the samples (Liu & Presuel-Moreno, 2014), as well as the composition of mixture ingredients (type of cementing materials). Moreover, ER results rely on pore connectivity and tortuosity and pore solution composition.

The effect of temperature and moisture content of concrete on ER is presented in Figure 2.14. Specimens with unsaturated (relative humidity (RH) of 92%, 82%) and saturated conditions were assessed under distinct temperatures (Liu & Presuel-Moreno, 2014). One may notice that the lower the RH, the higher the ER. Furthermore, the higher the temperature, the lower the ER. Otherwise this trend is not linear and presents an exponential decay.

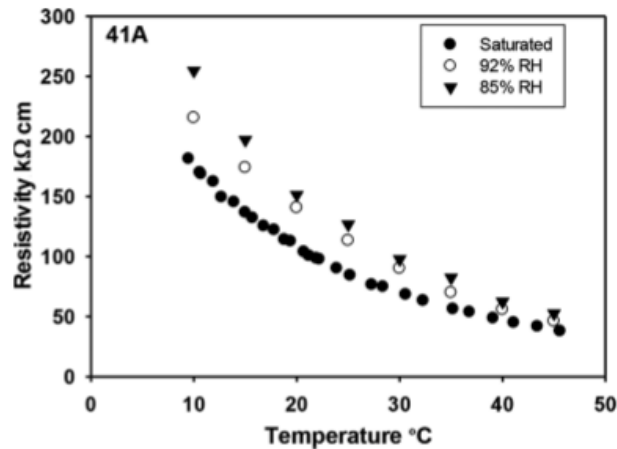

Figure 2.14: Concrete resistivity under relative humidity (saturated and unsaturated) and temperature (Liu & Presuel-Moreno, 2014)

There are several methods available for measuring the resistivity of concrete including bulk resistivity (two-point uniaxial), surface resistivity (four-point probe) and internal resistivity (embedded electrodes). Usually, concrete resistivity is measured in $k\Omega.cm$, and the measurements are based on Equation 2.8.

$$\rho = k.R \tag{2.8}$$

where R is the resistance of concrete, and k is a geometrical factor which depends on the size and shape of the sample along with the distance between the probes of the device.

A detailed concrete corrosion study was done by Layssi et al. (2015), where the authors described various techniques and the influences, especially for bulk and surface electrical resistivity. It was mentioned that concrete microstructure properties such as pore size distribution and shape may affect the durability and long term performance of concrete mixtures, as finer pores with fewer connectivity results in lower permeability (Layssi et al., 2015). However, a porous microstructure with more substantial interconnections causes higher permeability which also decreases the

durability of concrete. Therefore, it can be claimed that ER quantifies the conductive properties of concrete, providing an idea on its microstructure (size and extent of the interconnectivity of pores).

2.1.11 Sustainability and eco-efficiency in the concrete industry

The relationship between climate changes and CO₂ emissions has been very well established, and the PC industry is one of the most contributors regarding the carbon footprint of civil construction (Gartner & Hirao, 2015). Moreover, global PC production is expected to increase 2.5 times between 2005 and 2050 with the majority of this growth occurring in developing countries (Damineli et al. 2010).

Improving the efficiency of PC's use is one of the most important strategies for reducing CO₂ emissions. Such approach could result in an overall 15% reduction in cement consumption by the year 2050 (Damineli et al., 2010). This alternative has not been systematically investigated yet, but some key options have already been discussed to reduce PC consumption such as: (a) the use of high range dispersants, better known as superplasticizers; (b) the use of more efficient particle packing of concrete mixtures; (c) the increase in compressive strength and thus volumetric reduction of concrete's use in the field, and (d) a combination of these prior strategies leading to the production of "green mixtures" (Sanchez et al., 2016).

It has been suggested that a performance indicator might be developed to understand and quickly estimate PC efficiency in concrete, which would also help to produce a benchmark since there is little to no discussion in the literature on that matter (Damineli et al., 2010). Therefore, Damineli et al. proposed an index accounting for PC efficiency, the so-called *Binder Intensity Index (bi)*, which is defined as the amount of PC required to obtain 1 desired unit of a given concrete; e.g. the amount of PC in kg/m³ to obtain 1 MPa of compressive strength at a given time (i.e., 28 days), as given by Equation 2.9. There are several advantages of using the *bi factor*, from being a simple

concept to present a familiar outcome that once benchmarked, may be used for comparison with similar concrete families to assess the eco-efficiency of a given mix:

$$bi = \frac{B}{CS} \quad (2.9)$$

where, bi is the binder intensity index, B is the binder amount (in kg/m^3) and CS is the compressive strength in MPa. It is worth noting that the bi factor may be used as an indicator of a number of concrete properties other than compressive strength. Damineili et al (2010) benchmarked the relationships between the binder intensity index (bi) and the compressive strength of concrete mixtures used in Brazil and around the globe (Figure 2.15).

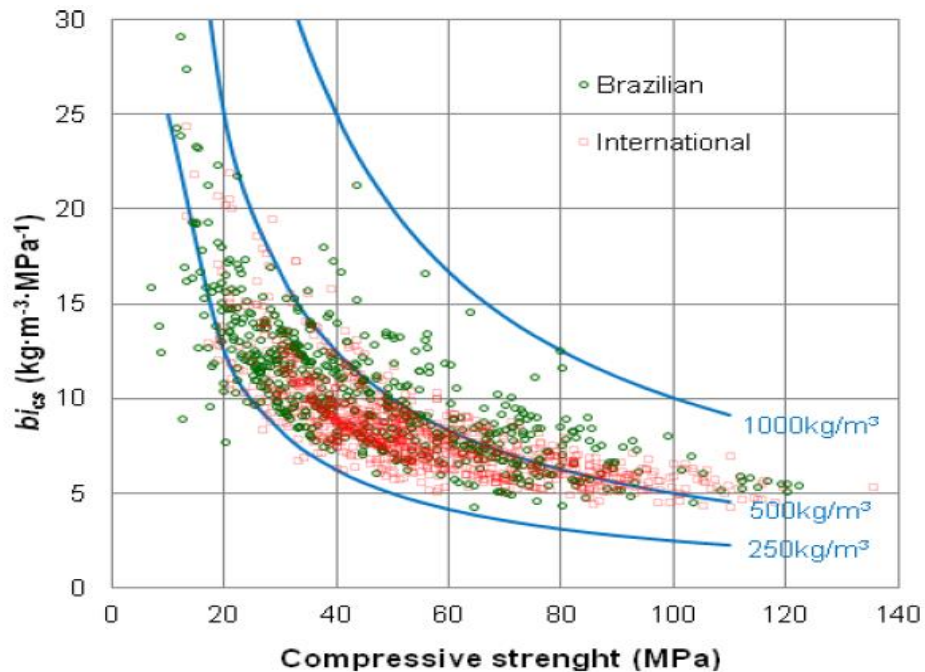

Figure 2.15: Binder intensity (bi_{cs}) vs. 28-day compressive strength for Brazilian (green dots) and international (red dots) data. The lines represent concretes with the same amount of total binder (Damineili, 2010).

It is interesting to notice from Figure 2.15 that the higher the compressive strength, the lower the b_i factor. In other words, high strength concrete mixtures implicitly have low b_i indices or lower carbon footprint. However, high to very high b_i factors are obtained in conventional concrete mixtures used in civil infrastructure (i.e. compressive strength ranging from 20 to 40 MPa), which might be claimed as the most frequent concrete-type classes used worldwide. The latter highlights the need for the optimization of conventional concrete mixtures towards a PC reduction and thus greener future in civil engineering.

2.2 Gap in the State-of-the-Art

It is clear from the previous sections that there is a lack of results demonstrating the efficiency on the use of particle packing models (PPMs) to improve the behaviour of concrete mixtures in the fresh and hardened states. Moreover, the use of PPMs as a means of reducing PC and thus increasing binder efficiency while maintaining (or increasing) performance was barely discussed in the past, needing thus further development.

This project aims to analyze and quantify the behaviour of conventional (CC) and low cement content (LCC) concrete mixtures designed with conventional (i.e. ACI method) and continuous particle packing models (i.e. Alfred model) to increase both performance and binder efficiency in concrete mixtures. In this research, two conventional concrete types (i.e. 25 and 35 MPa) were designed and fabricated through conventional and PPM techniques. Three distinct q factors were selected according to the literature (i.e. 0.26, 0.31 and 0.37) for comparison purposes. Several properties in the fresh and hardened states were evaluated over time and discussions on the use of LCC systems for structural applications is performed. Future research needs are also highlighted.

CHAPTER 3

3.1 Structural Concrete with lower cement amount using continuous Packing Model: An Eco-Friendly Alternative for Construction Industry

Yousuf. S.^a, Sanchez L.F. M.^b, Santos V.A.A.^c, Shammeh. S.A.^d,

(a) MAsc Student – University of Ottawa

(b) Prof. Dr. – University of Ottawa

161 Louis-Pasteur, Ottawa, Ontario, Canada, K1N 6N5

Department of Civil Engineering

leandro.sanchez@uottawa.ca

(c) Post-doctoral Fellow – University of Ottawa

vito.alencar@uottawa.ca

(d) Undergrad Student - University of Ottawa

ABSTRACT

Pressure is mounting in the civil construction industry to adopt more environmentally sustainable methods to reduce CO₂ emissions. It is essential that the concrete industry consider its carbon footprint amongst increasing demand and tightening environmental restrictions. One of the most efficient methods used to mediate this impact is to use concrete systems with low cement content, the so-called low cement content (LCC) concrete. This material addresses the issue in an innovative and eco-friendly manner through the use of more efficient mix-design strategies and by-products from other industries. Although sustainable, the use of LCC concrete in structural applications is relatively new, and its performance and long-term behaviour are still relatively unknown. This project aimed to mix- proportion concrete mixtures with reduced cement amount through the use of packing theories. Evaluations were performed in the fresh and hardened states of the material, while gaps, recommendations, and further needs were highlighted. Results

indicated that the use of packing models seems to enable the development of LCC systems with engrossing performance in the hardened state while presenting reasonably small environmental impact. Otherwise, particular attention should be taken on the fresh state properties of highly packed mixtures, which might be improved through the use of admixtures (i.e., plasticizers), fillers and or even supplementary cementing materials (SCMs).

Keywords: *low cement concrete, packing model, q factor, maximum paste thickness, binder intensity factor.*

3.1.1 INTRODUCTION

As the developed world expands day by day, the demand for additional civil infrastructure rises, and since concrete is one of the most common materials used for such types of structures, the use of concrete has increased 400% between 1990 and 2002, which causes a significant environmental impact worldwide [1,2]. Portland cement (PC) is the most commonly used binder in concrete, and its production requires high amounts of energy releasing a considerable amount of CO₂ [3]. According to the 2003 Intergovernmental Panel on Climate Change (IPCC), the cement industry caused 5% of anthropogenic CO₂ emissions [2]. Moreover, in developing countries, the global cement production is expected to increase by 2.5 times in the next 40 years [2]. To reduce the overall CO₂ emissions, supplementary cementing materials (SCM) have been used as a partial replacement of PC. Likewise, increasing the binder intensity (bi) factor (i.e., amount of strength developed per binder mass unit [2]) was seen to be an attractive strategy to decrease concrete carbon footprint [4].

In standard concrete mix designs, the cement content used is typically high and is selected empirically as a function of the consistency targeted (i.e., slump), water-to-cement (w/c) ratio needed to build a required strength along with the maximum size and volumetric amount of the

coarse aggregate. In such methods, there is no thorough evaluation and selection of the materials gradation (or particle size distribution - PSD). It has been found that the use of packing model theories (either discrete or continuous) could lead to a significant reduction in the cement content by improving the aggregate skeleton distribution [5,6]. The packing model's approach is based on the idea of optimizing the PSD or grading of the aggregates skeleton in concrete [2-4,7]. One of the first models proposed was Fuller-Thompson's model in 1908 [5]. Over the past century, packing models have been expanded and researched repeatedly. Two categories of models were developed over the years: discrete models and continuous models.

Brouwers [6] defines discrete models as procedures that work with "narrowly defined size classes of particles such as monodisperse, bimodal or even narrow size cuts of multimodal particles." Therefore, in concrete technology applications, discrete approaches refer to the packing of multimodal distributions containing "n" discrete size classes of particles, the so-called gap-graded systems [6]. Otherwise, continuous particle packing models consider continuously sized particles available in the mixture (i.e., no gaps throughout the whole PSD). Moreover, it assumes a similarity condition for particle packing, which means that the array of particles (in other words "granulation image") surrounding every particle in the distribution should be similar, regardless of the size of the particle [3]. The latter approach is considered compelling in concrete technology since most of the concrete components, at least in theory and for materials designed for conventional applications, might be treated as continuous PSDs.

3.1.2 BACKGROUND: PACKING MODELS

The first investigations concerning particle packing in materials started around 200 years ago [7]. The packing of a particle system is a function of PSD, particle shape, texture, the presence of liquids, etc. According to Dinger, the PSD of a granular material directly affects the packing of a

system of particles, which causes the particle packing to be an essential parameter to granular systems [7]. There are two types of particle packing models (PPMs) which are discrete and continuous.

The discrete approach refers to the packing of multimodal distributions containing two or more discrete size classes of particles. According to this method, coarse particles are packed densely first, forming the structure within which smaller particles are packed. Dinger also demonstrated that in a three-component packing, the midsized particles are packed into the pores formed by the coarse particles, and the smaller particles are packed into the pores formed by the midsized particle particles up to the highest packing density [7].

Continuous packing models are described having a wide PSD where all possible sizes are present in a mixture as continuously graded. The adjacent classes in the continuous distribution have ratios that approach 1:1 and no gaps exist between size classes. The beginnings of the continuous approach were developed in the late 1920's by Andreassen, where it was recognized that the most common experimental distributions were continuous [7], while most of the discrete distributions were actually narrow continuous distributions.

A continuous PSD curve can be described by a power function as given by Equation 3.1, with a distribution factor q , to adjust the shape of the distribution curve. Andreassen suggested that the optimal q factor should range between 0.33 and 0.50, with minimum particle size, d_0 equal to zero. These values were obtained through mathematical and theoretical models [6]. In 1980, Funk and Dinger recognized the need to have a finite size for the smallest aggregate and the effect such an assumption would have on the particle packing. This last approach gave rise to the so-called Alfred or modified Andreassen model [8]. In this model, the q factor represents the distribution coefficient for defined minimum and maximum particle sizes.

$$CPFT = (d - d_0/D - d_0)^q \times 100 \quad (3.1)$$

where CPFT is the cumulative volume percent finer than d , d is the particle size, d_0 is the minimum particle size, D is the maximum particle size, and q represents the distribution factor. To achieve maximum packing density, the minimum particle size should be equal to zero. Since this is impossible in reality, the lower the minimum particle size used, the denser is the packing.

The theoretical model priorly discussed is based on assumptions of perfect spheres, smooth particle surfaces and no attracting or repelling forces between particles, which very likely does not happen in reality. Moreover, entirely packed mixtures would bring limitations of flowability, thus not being suitable for concrete mixes in the fresh state. Finally, some of the parameters that are not considered in the Alfred model can indeed change the packing density of concrete mixtures, such as morphology (shape and texture), porosity (within the aggregate particles and cement paste), wall effect, and different compacting techniques. According to Fruhstofer and Aneziris [9], as well as to Alfred and Zinger [8], the densest packing model can be achieved with a q factor equal to 0.37, which would likely bring benefits to the short and long-term hardened state properties of concrete along with a decrease in the binder content of the mixture. Otherwise, according to Vogt (2010), it has been found that whether the distribution factor increases above 0.37, the porosity of a system rises instantly, yet the same trend was not observed for q values lower than 0.37 [10].

Vogt [10], using Westman & Hugill approach, calculated the expected porosities for concrete mixtures designed with different q values (Figure 3.1). They pointed out that for wide PSDs, q values ranging from 0.20 to 0.40 might still be useful to design densely packed mixtures. However, no quantitative data was provided on the different properties found in the fresh or hardened state/durability achieved through the use of distinct q values. Likewise, most of the concrete mixtures designed through the use of PPMs found in the literature present moderate to high binder

amounts (greater than 375 kg/m^3). Hence, there is currently only a few data available quantifying the influence of the use of continuous packing models on the short and long-term performance of structural conventional concrete mixtures with low environmental impact (e.g., low cement content).

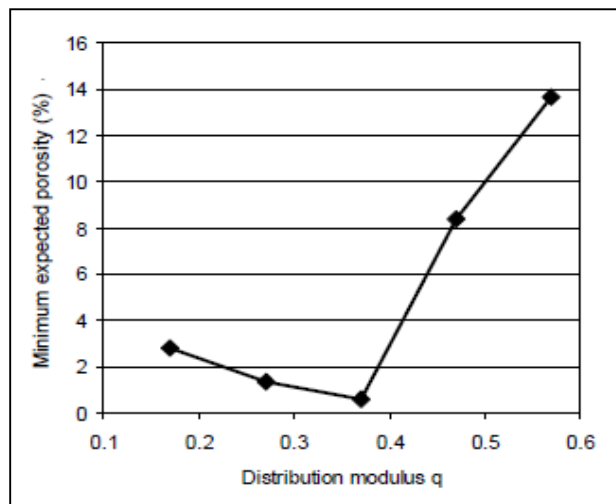

Figure 3.1: Relation between expected porosity and q-value [10].

3.1.3 SCOPE AND OBJECTIVES OF WORK

This project aims to analyze and quantify the behaviour of concrete mixtures designed with the use of the Alfred continuous PPM to increase binder efficiency in concrete. Three q factors were selected in this research and properties in the fresh (i.e., slump test, air content and density) and hardened state (i.e., compressive strength, bending flexure, stiffness damage test, ultrasonic pulse velocity, electrical internal resistivity and surface resistivity) are measured and analyzed. Comparisons are made between concrete mixtures designed by PPM and conventional methods, and discussions on the possibility of using LCC systems for structural applications is performed.

It is worth noting that LCC is defined in the context of this work as a concrete mixture presenting an amount of cement lower than the minimum required in North America for harsh climates and flat works according to ACI 302 (i.e. 335 kg/m³).

3.1.4 MATERIALS AND METHODS

Materials and mixture proportions

Three concrete types presenting different q factors (0.26, 0.31 and 0.37) were selected to fabricate 35 MPa and 25 MPa mixtures. The idea was to choose q factors that would provide the mixes with a high, moderate and low amount of fines, respectively [13]. A fourth concrete mixture (for both 25 and 35 MPa mixes), following the conventional “absolute volume” method (i.e., ACI method), and presenting the same w/c ratio, was designed for control purposes. Using Abrams Law, the w/c ratios selected for the mixtures were 0.61 and 0.47 for 25 and 35 MPa, respectively, and kept constant in all mixes [14]. Batches of 32 liters (roughly 15 cylinders per batch) were cast for each q factor, as well as for the control mixtures and thus the various tests in the fresh and hardened states were conducted on the mixes.

CSA (Canadian Standards Association) Type GU (General Use) Portland cement was used for this research. The chemical and physical properties of the cement are presented in Table 3.1. Natural sand (i.e. with particles smaller than 4.75 mm) was used as fine aggregate, while crushed limestone with particles ranging from 5 to 20 mm in size was selected as coarse aggregate. To characterize the aggregates, water absorption and specific gravity were performed according to the standard procedure proposed by ASTM C128 – 15 [11] for fine aggregates and ASTM C127 – 15 [12] for coarse aggregates. Results of the moisture content and absorption are presented in Table 3.2. Table 3.3 shows values of specific gravity for fine and coarse aggregates.

Table 3.1: Physical and chemical properties of the Portland cement.

Chemical Composition (%)	CaO	59.9
	SiO ₂	19.0
	Al ₂ O ₃	4.8
	SO ₃	4.0
	Fe ₂ O ₃	3.7
	MgO	2.3
Residue on 45 μ (%)		4.7
LOI at 1150 °C (%)		2.0
Blaine (m ² /kg)		436

Table 3.2: Moisture content and absorption of course and fine aggregates.

	Moisture Content (%)	Absorption (%)
Coarse	0.16	0.22
Fine	0.47	1.08

Table 3.3: Specific gravity for aggregates.

Particle Size	Specific Gravity (kg/l)
100 μm	3.15
2.38 mm	2.70
4.5 mm	2.62
9.5 mm	2.62
12.5 mm	2.62
19.0 mm	2.62

Using Alfred Model and the three distribution factors previously presented, the mix- proportioning of the concrete mixtures was performed. Three distinct zones were considered in the PSD: a) binder/fines: all the material smaller than 100 μm ; b) sand: from 100 to 4750 μm ; and c) coarse aggregates: from 4750 to 19000 μm . Aggregates were sieved according to ASTM Standard C136 [15] to obtain the grading proportions provided by the different q factors. For the coarse aggregates, the meshes selected were the ones typically used in conventional structural concrete, from 25 – 19 mm to 9.5 - 4.75 mm; while for the fine aggregates, the meshes used were from 4.75 mm (No. 4) to 0.15 mm (No. 100). Table 3.4 illustrates the 25 and 35 MPa mix-designs used in this project.

Table 3.4: 25 MPa and 35 MPa mix design and w/c ratio for distinct q factors.

q factor	Cement	Fine Aggregate	Coarse Aggregate	25 MPa mix	35 MPa mix
	kg/m^3			w/c	
q ₁ : 0.26	401	814	1007	0.61	0.47
q ₂ : 0.31	341	808	1132		
q ₃ : 0.37	277	789	1285		
ACI (25 MPa)	314	783	1024		
ACI (35 MPa)	370	783	1024		

It is worth noting that chemical admixtures and or supplementary cementing materials were intentionally not added to the concrete mixtures so that a benchmark on the behaviour of mixes designed though the use of PPMs could be developed and compared to conventional methods.

Moreover, it is believed that the introduction of those materials would have brought new variables to the system, making more complicated the understanding of the research outcomes and the influence of the different variables assessed.

Fabrication, curing of testing of the specimens

Twelve 100 by 200 mm concrete cylinders were fabricated for each of the four different concrete mixtures (i.e., three using PPMs with distinct q factors and 1 using the ACI method) as per ASTM C-192/C192M [16]. Eight prismatic 400 x 100 x 100 mm specimens were also fabricated and used for flexural analysis.

While casting, test procedures were performed in the fresh state on the four different mixtures, such as slump test [18], air content [19], and density [20]. After 24h from casting, the specimens were demolded and moist cured over time up to testing. Test methods were then conducted to evaluate some hardened state properties such as compressive and flexural strength, stiffness damage test, internal and surface electrical resistivity.

Compressive strength was measured at 3, 7, 14 and 28 days of curing age as per ASTM C39M - 17b [21]. Three cylinders were tested from each mixture at each time period with a 3,000 kN capacity compression testing machine at a loading rate of 4.5 kN/s. Flexural strength test was conducted with a 1,000 kN capacity Universal Test Machine (UTM) by third-point loading test at 28 days as per [17] (Figure 3.2). Two prims per mixture were selected for flexural testing.

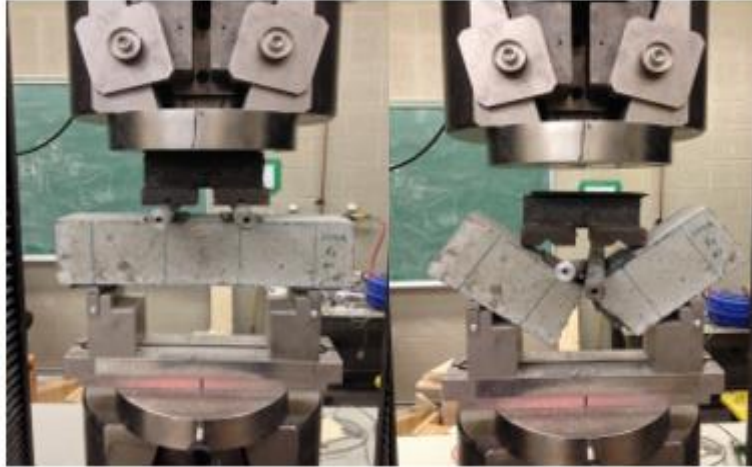

Figure 3.2: Flexural strength test was conducted on UTM of capacity 1000 kN by third point loading at 28 days.

The Stiffness Damage Test (SDT) was carried out on all concrete mixtures (i.e., 25 and 35 MPa mixes using PPMs and conventional methods). Three cylinders of each mixture were subjected to five loading/unloading compressive cycles, using a loading level of 40% of their 28-day compressive strength as per Sanchez [25]. The goal of the SDT was to quantify the damage degree or even the quality of the mixtures through analysis on the presence of flaws/imperfections in the concrete samples. The test procedure was first developed by Walsh [26] and was recently optimized by Sanchez [27]. This technique allows the damage characterization in concrete through three main outcomes: 1) the modulus of elasticity (calculated as the average of the modulus obtained in cycles 2 and 3) as well as the 2) Stiffness Damage Index (SDI) and 3) Plastic Deformation Index (PDI), which are respectively the ratio between the dissipated energy or plastic deformation placed over the five loading/unloading cycles and the total energy or deformation obtained over the five cycles [27].

Non-destructive techniques were also carried out on all the concrete mixtures appraised. Electrical resistivity (ER) of materials was measured with devices provided by Proceq and Giatec Scientific

Inc. The measurements of the surface ER were made based on the four-probe (Wenner-Array) technique [22]. Four measurements were taken on each specimen, and average values were calculated from them. The device automatically measures ER around the concrete specimen using four channels of the 4-probe array as presented in Figure 3.3: .

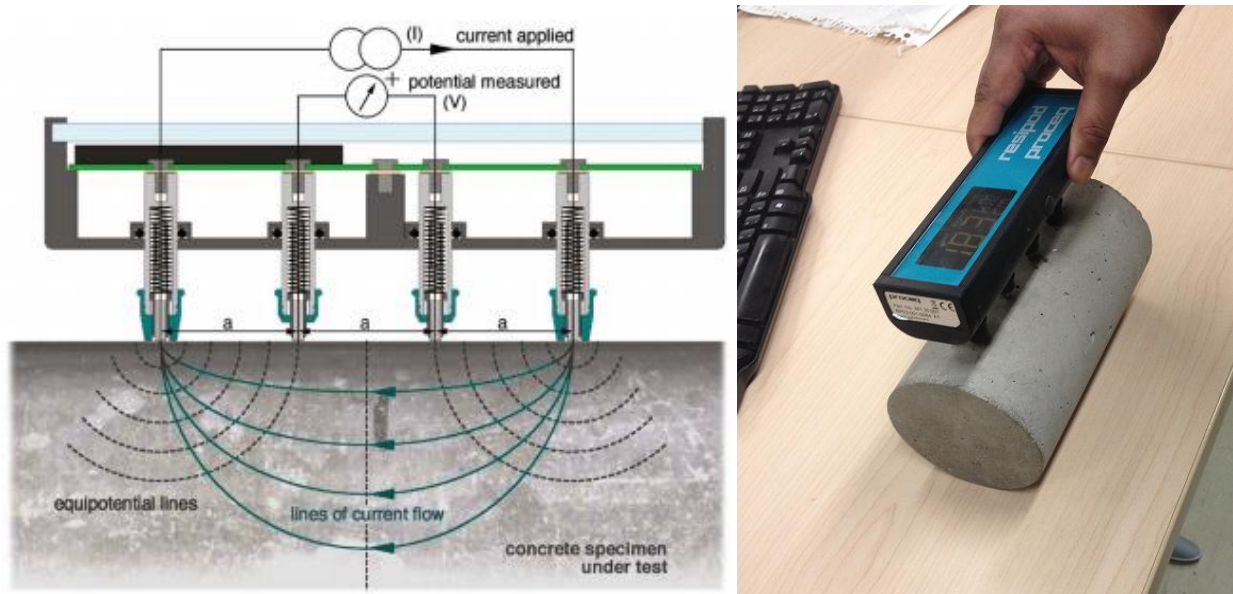

Figure 3.3: Schematic representation and picture of the experimental device used for the measurements of surface resistivity of concrete specimens [23].

The internal resistivity was assessed using a commercially available sensor that measures both ER and internal temperature. This sensor is comprised by three main components: two electrodes, a data acquisition unit and a thermocouple (Figure 3.4:). The electrodes were placed into the cylinders after concrete was cast and compacted. The thermocouple was then inserted at the center of each cylinder. The mixture was then slightly vibrated to ensure that the electrodes and thermocouple were strongly embedded in concrete and not loose, as per Tomlinson [24]. The geometric factor used was 9.13. Table 3.5 shows the testing matrix performed over the current experimental campaign.



Figure 3.4: Schematic representation and picture of the experimental device used for the measurements of internal resistivity of concrete specimens.

Table 3.5: Global Testing Matrix.

Mixes	Compressive Strength				Third-point Loading	SDT	Surface Resistivity	Internal Resistivity
	3d	7d	14d	28d	28d	28d	28d	28d
ACI	3	3	3	3	2	3	3	3
q1	3	3	3	3	2	3	3	3
q2	3	3	3	3	2	3	3	3
q3	3	3	3	3	2	3	3	3

3.1.5 EXPERIMENTAL RESULTS

The following sections present the results of testing carried out to evaluate the fresh and hard state properties of the different concrete mixtures evaluated. These results are often based on the average value of three specimens at a given age and from a given mix.

PSD for PPM and conventional mix- designed concrete mixtures

Three concrete mixtures were designed using Alfred (or modified Andreassen) continuous PPM, where the values assumed for the distribution factors (q) were 0.26, 0.31 and 0.37 (Figure 3.5).

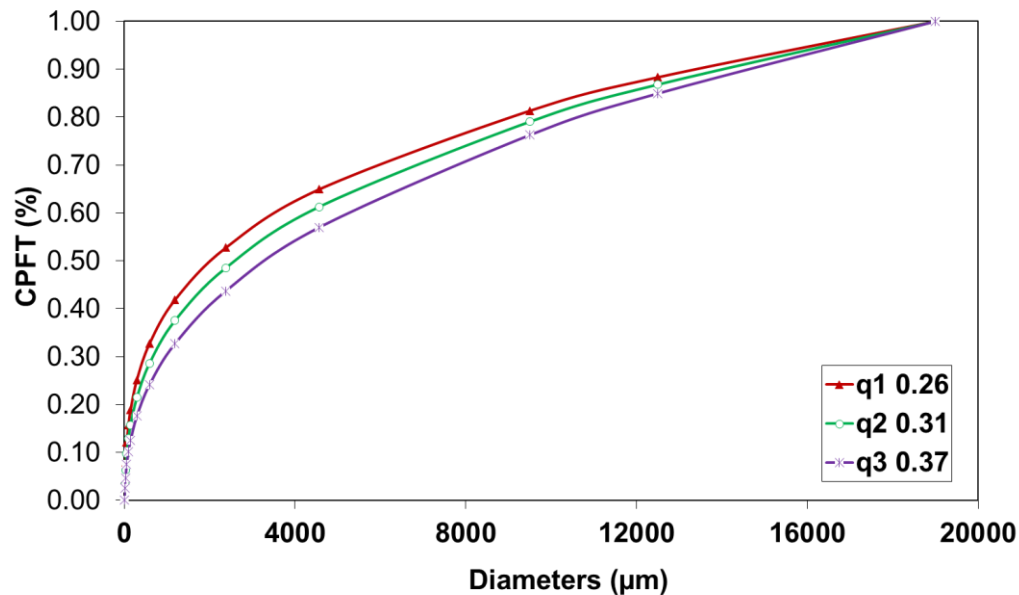

Figure 3.5: Cumulative particle size distributions of the three concrete compositions designed using Alfred continuous PPM, where CPFT = cumulative percentage of particles finer than a specific size.

The reference mixture was conventionally designed through the use of ACI method. The lower value of q_1 (0.26) was selected to provide the concrete mixture with a high amount of fine particles (i.e. cement content in this case), comparable to the ones used in North America market for a wide range of applications. The intermediate q value (0.31) was chosen so that the amount of cement would be close to the minimum binder amount required in North America for concrete under harsh climates according to ACI 302 (i.e. 335 kg/m^3), and finally the highest q factor (0.37) was used to provide the mixture with the least amount of porosity and thus fine materials (i.e. cement content) as per Westman & Hugill, which enables the proportioning of a LCC mix.

Fresh state behaviour

Figures 3.6 and 3.7 show the relationship between slump measurements and the corresponding q values for 25 and 35 MPa mixes, respectively.

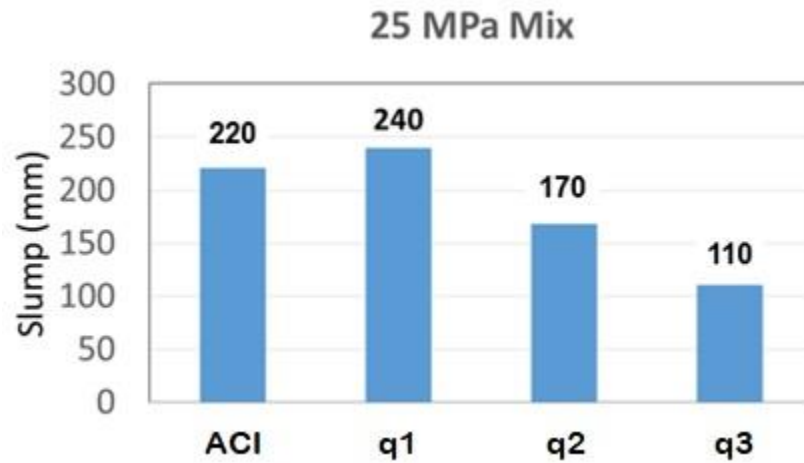

Figure 3.6: Slump value for 25 MPa concrete mixes.

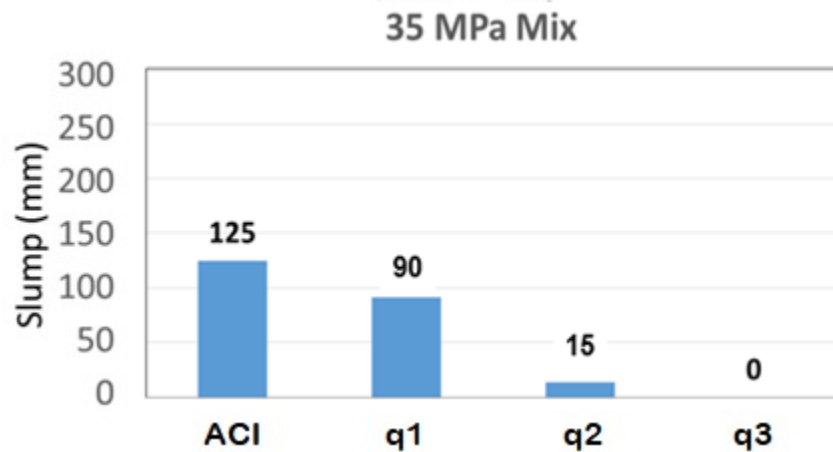

Figure 3.7: Slump value for 35 MPa concrete mixes.

Looking at the above figures one may notice that for 25 MPa mixtures, the slump values obtained for the mixes designed by ACI and PPM (q1) methods were quite high and close (220-240 mm).

Otherwise, the consistency values decreased for the mixes designed with PPMs as a function of the q value used. The higher the q factor, the lower the slump value obtained. The values obtained were 170 mm and 110 mm, respectively, for mixtures designed with PPM and q factors of 0.31 and 0.37. The same general trend was found for the 35 MPa mixes, although this time the slump found for the conventional mixture designed with PPM with distribution factor q1 (90 mm) was lower than the ACI mix- designed concrete (125 mm). The concrete mixes designed with PPMs with q2 and q3 showed 15 mm and zero slump, respectively.

Figures 3.8 and 3.9 illustrate the density values obtained for the 25 and 35 MPa concrete mixtures in the fresh state, respectively. Differently from the slump values, one sees that mixes with higher q-values presented higher densities for both concrete types. The values ranged from 2,541 kg/m³ to 2,636 kg/m³ for the 25 MPa mixes and from 2,577 kg/m³ to 2,681 kg/m³ for the 35 MPa mixtures.

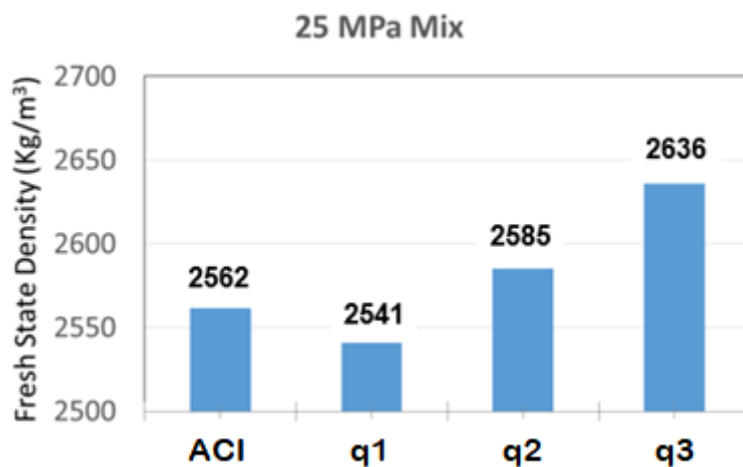

Figure 3.5: Fresh state density for 25 MPa concrete mixes.

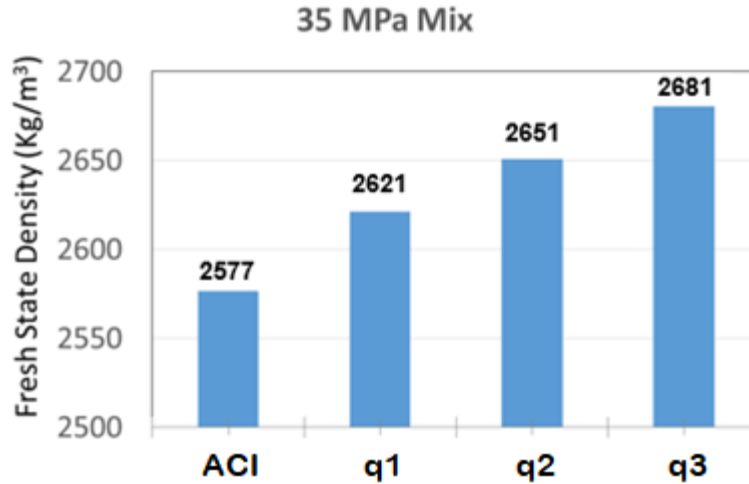

Figure 3.6: Fresh state density for 35 MPa concrete mixes

Compressive strength

Figure 3.10 shows the 25 MPa compressive strength values over time (i.e., 3 to 28 days) obtained for the concrete mixtures evaluated in this project. Analyzing the results, one verifies that all the designed 25 MPa concrete mixtures reached or overcame the targeted strength much before 28 days. Additionally, the q3 and q2 mixes (higher packing density) reached the targeted strength at lower ages (14 days).

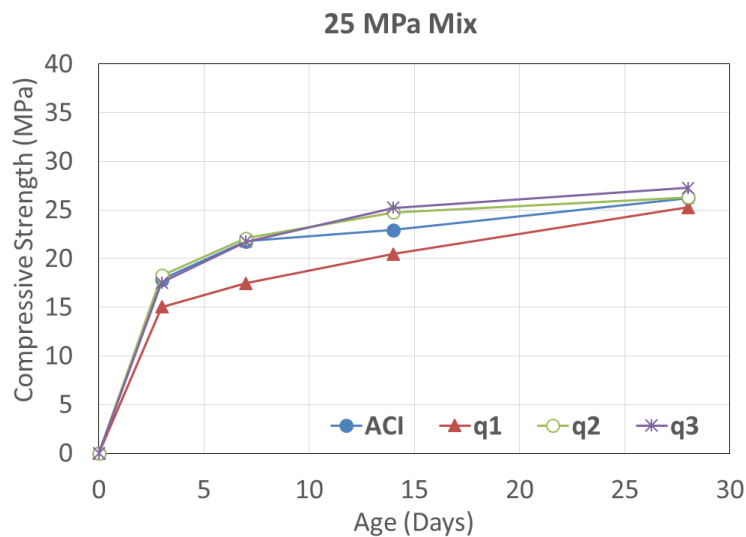

Figure 3.7: Compressive strength at distinct ages for 25 MPa concrete mixes.

Similarly to 25 MPa, all the 35 MPa concrete mixtures reached the targeted strength before 28 days (Figure 3.11). However, differently from the 25 MPa concrete, all the mixes made by PPM developed quite similarly their compressive strength over time.

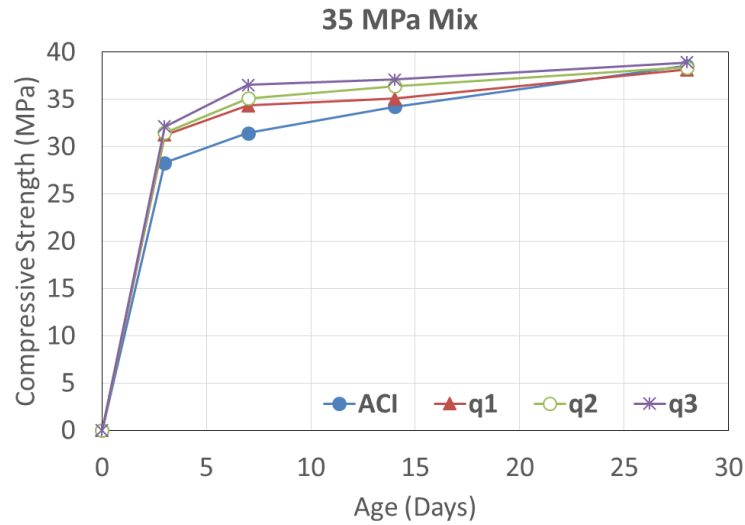

Figure 3.8: Compressive strength at distinct ages for 35 MPa concrete mixes.

Also, it could be seen that q3 presented higher strength at lower ages, while the reference mix seemed to slowly increase its strength over time. Despite of the smaller cement amount of q2 and q3 mixes, all 35 MPa concrete family presented similar compressive strength at 28 days.

Surface electrical resistivity

Figures 3.12 and 3.13 present the relationship between the surface resistivity over time for the 25 and 35 MPa concrete mixtures, respectively. The surface resistivity graphs showed two remarkable trends: 1) it increases as a function of time for all mixes and; 2) it seems to be higher for higher packing density mixes for all ages. The only exception was 25 MPa q1 and q2 mixes that presented close results throughout the analysis timeframe. Moreover, the resistivity curves showed for all mixtures a “concave shape” as a function of time, quite similar to their compressive strength gain.

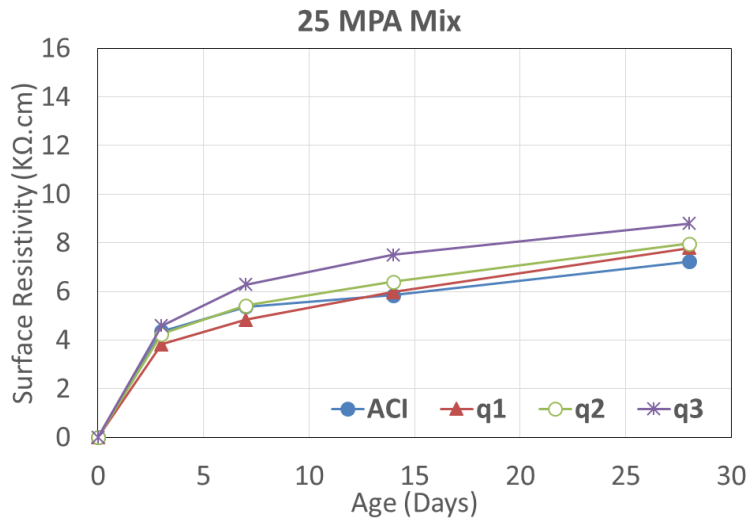

Figure 3.9: Surface resistivity values at distinct ages for 25 MPa concrete mixes.

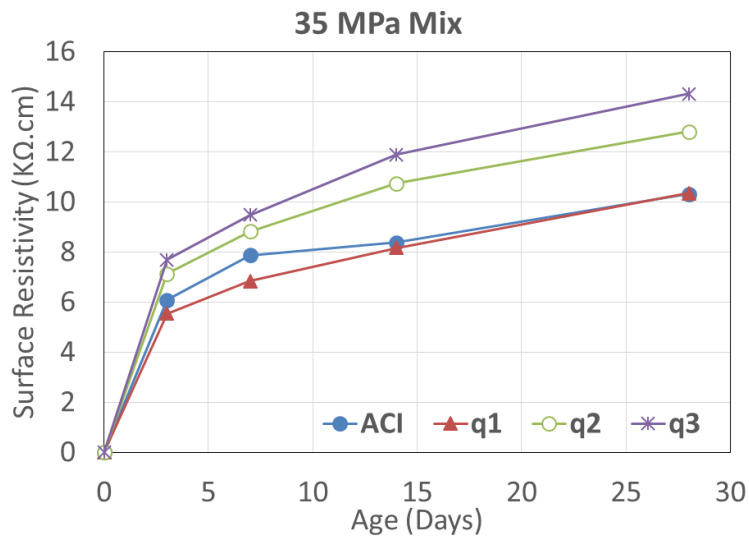

Figure 3.10: Surface resistivity values at distinct ages for 35 MPa concrete mixes.

Internal electrical resistivity

The internal measurements of electrical resistivity for 25 and 35 MPa concrete mixtures are presented in figures 3.14 and 3.15, respectively.

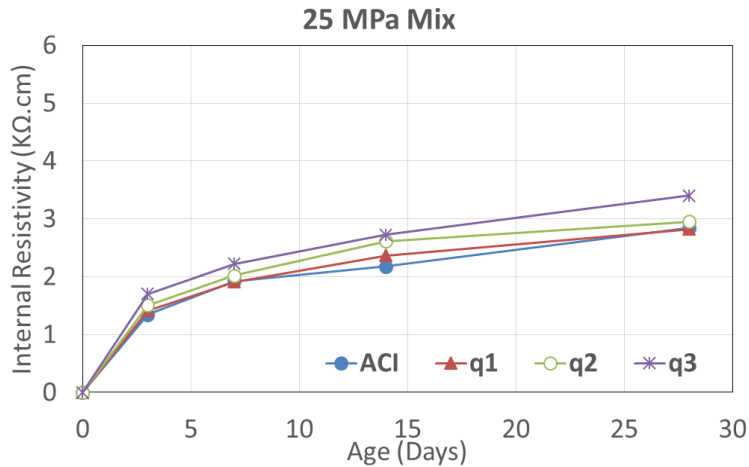

Figure 3.11: Internal resistivity values at distinct ages for 25 MPa concrete mixes.

In the 25 MPa mixes plot, one may see that all mixes showed similar results over time, with q3 reaching a slightly higher value after 28 days. However, significantly higher results, in distinct ages, were obtained by 35 MPa q3 mixture, in comparison to other mixes in this family. Overall, 35 MPa mixtures presented higher internal resistivity than 25 MPa mixes, as expected.

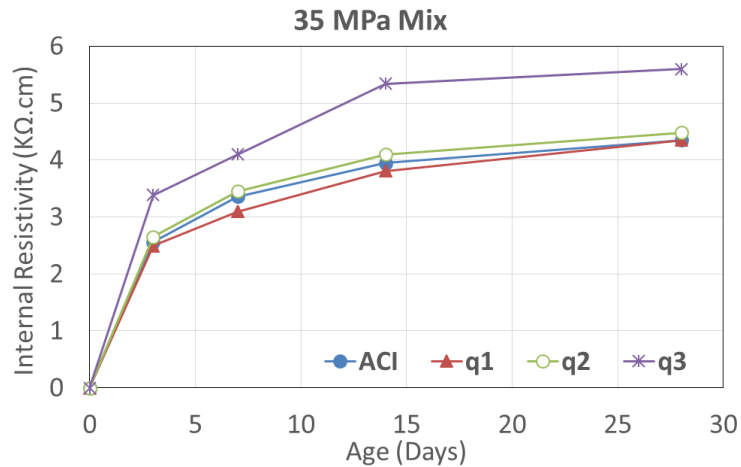

Figure 3.12: Internal resistivity values at distinct ages for 35 MPa concrete mixes.

Flexural Strength: Modulus of Rupture

Figure 3.16 shows the modulus of rupture results for 25 MPa concrete mixtures. Analyzing the data, one sees that the value obtained by the ACI mix was lower (3.9 MPa) than PPM mixes (4.6

– 4.7 MPa). The same behaviour can be observed for the 35 MPa concrete mixtures (Figure 3.17), where PPM mixes reached values between 5.3 and 5.5 MPa, while the ACI mix result was 4.8 MPa.

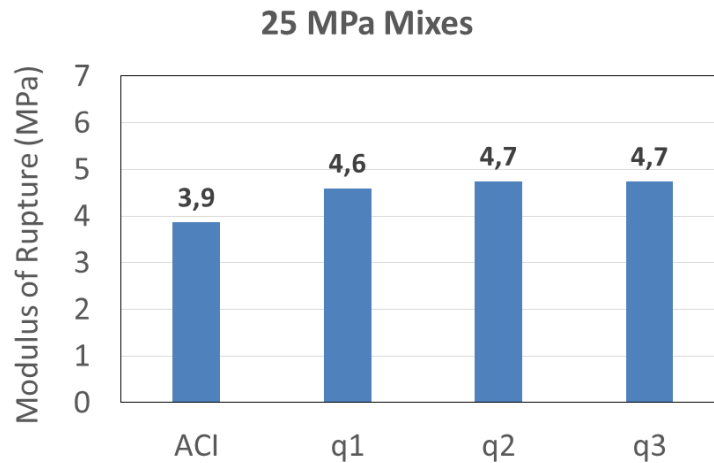

Figure 3.13: Modulus of Rupture for 25 MPa concrete mixes at 28 days.

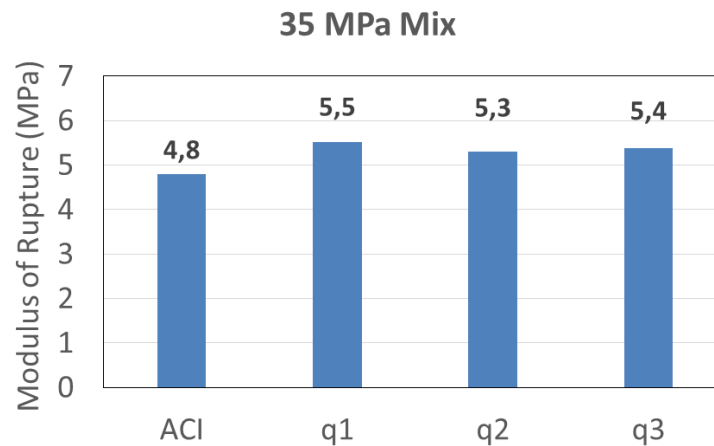

Figure 3.14: Modulus of Rupture for 35 MPa concrete mixes at 28 days.

Stiffness Damage Test

Stiffness Damage Test (SDT) results are found in Figures 3.18 and 3.19. Analyzing the results of the plots, it is possible to notice that the higher the q-values, the higher the modulus of elasticity

obtained for both 25 and 35 MPa mixtures. The results ranged from 22.3 GPa to 37.1 GPa for the 25 MPa mixes, while it ranged from 28.7 GPa to 45.3 GPa for the 35 MPa mixtures. However, the SDI and PDI indices did not present any variations for both 25 and 35 MPa mixes as a function of the packing density (i.e. all the mixtures presented SDIs and PDIs equal to 0.09).

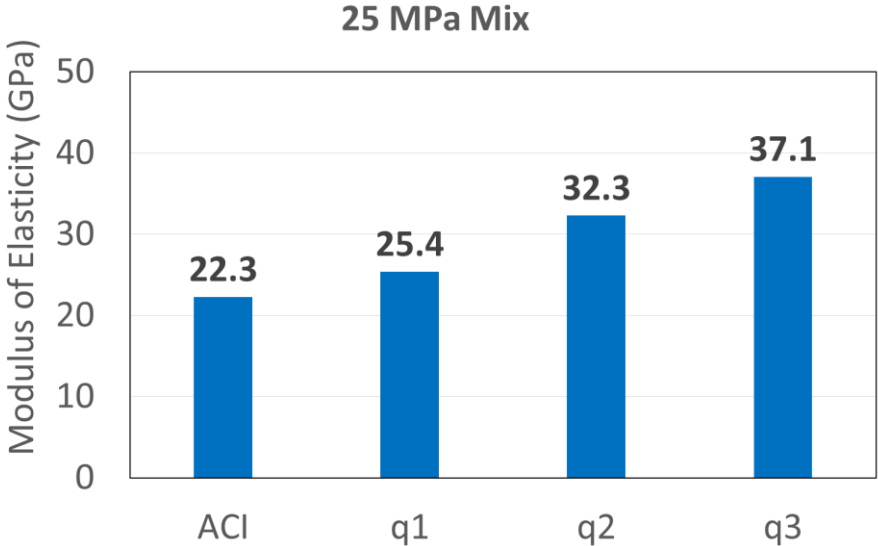

Figure 3.15: Modulus of Elasticity for 25 MPa concrete mixes at 28 days.

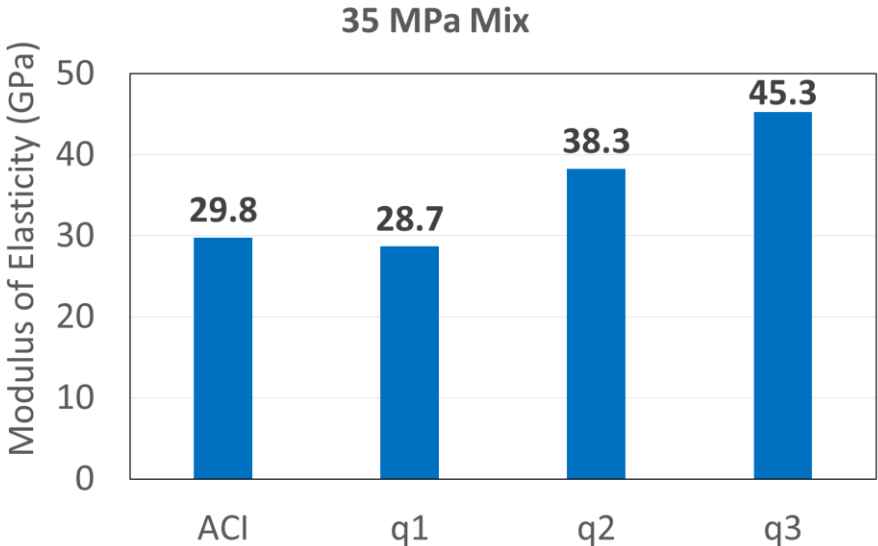

Figure 3.16: Modulus of Elasticity for 35 MPa concrete mixes at 28 days.

3.1.6 DISCUSSION

Fresh state properties

Slump is a practical and in-situ test for measuring the consistency of concrete. Although quite simple and unable to fully explain the rheological behaviour of concrete in its fresh state, it is used extensively worldwide to make necessary decisions regarding concrete consistency (often called wrongly as “workability” in practice). In this work, the use of chemical and/or SCMs/filler was avoided so that one might benchmark the use PPM mix- designed conventional systems.

Assessing the results obtained in this work, one verifies that the higher the packing density, the lower the slump (or, the higher is the material consistency). This is very likely related to the higher amount of smaller particles ($< 4750 \mu\text{m}$ size) presented in mixture q1 when compared to q3, and also probably more important, the higher amount of binder (or PC) in q1, which acts as a lubricant between larger particles in the fresh state and enhances the mixture flow. Moreover, the effect of packing models in the concrete consistency showed to be more critical in systems containing less amount of water (i.e., 35 MPa mixtures). That seems to indicate that water can also act as a lubricant and thus allow the binder reduction, causing less impact on their fresh state behaviour. Hence, the prior results seem to indicate that although reduced cement systems through the use of higher packing densities demand less amount of water to enable flow, the presence of much higher interaction forces (friction) among the aggregates seems to be a limiting factor already in systems with moderate amount of water. Therefore, particular attention should be taken for LCC systems regarding fresh state behaviour.

It is widely known in concrete technology that some classes of chemical admixtures (i.e. plasticizers, especially the so-called high range or superplasticizers), supplementary cementing materials (SCMs) and even fillers may enhance the flow and consistency of concrete mixtures for the same amount of binder and water in the system.

In this work, in order to evaluate the effect of superplasticizers (SP) on LCC regarding practical purposes such as their effective performance on reduced cement systems, a polycarboxylate-based SP with a solid concentration content of 20% was selected for use in 35 MPa LCC concrete mixtures designed through PPM using q_3 . Three percentages of SP dosage were selected (i.e. 2, 4 and 8%) by cement mass. The water amount present in the superplasticizer was considered in the design to keep the same initial w/c ratio. Figure 3.20 illustrates the consistency results obtained as a function of the SP percentages used.

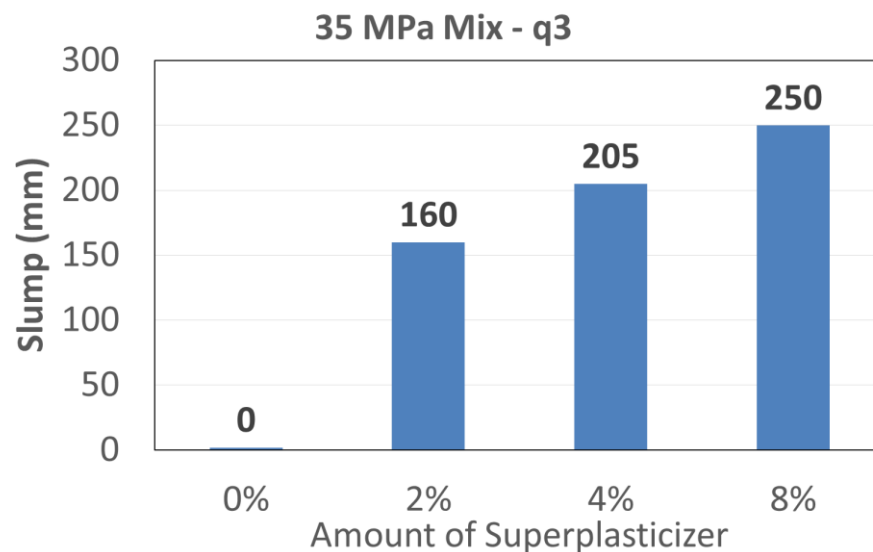

Figure 3.20: Influence of amount of superplasticizer on the slump value for 35 MPa concrete mix with distribution factor q : 0.37.

Analyzing the above data, one verifies that although without SP the slump value obtained was zero, SP additions were effective in decreasing the consistency (or enhancing the slump) of the 35 MPa LCC mix. Slump values of 160 mm were already reached with 2% SP, while 205 mm and 250 mm were achieved with 4% and 8%, respectively, which demonstrates SP's efficiency in enhancing the flow in LCC systems. The results used (especially 4 and 8%) can be considered high in practice, and thus further work is still needed on the optimization of SP's use, likely

incorporating other materials that might contribute to the overall fresh state behaviour, such as SCs and fillers.

Besides consistency, the results presented in section 5.2 also highlighted the effect of PPMs on the fresh state density of concrete mixtures, including LCC systems. Results showed that the density of the concrete in the fresh state significantly increased as the concrete mix became more densely packed according to the different q-values used. These results indicate that better packed concrete might then result in advantages on durability and long-term performance. Moreover, the density of the mixtures was not linked to the amount of binder used (actually it was the opposite), which could help to change the misconception that LCC systems cannot be cohesive and/or durable enough due to the lack of binder. These results also show that LCC system could also improve the quality of concrete regarding creep and shrinkage. However, further tests are necessary.

Hardened state properties

- *Mechanical Properties*

The compressive strength tests were completed at 3, 7, 14 and 28 days. As stated in the literature, the compressive strength of concrete is governed by the water-to-cement ratio (and its porosity), which is typically set by Abrams' Law [14]. Since the mixtures studied in this project presented the same water to cement ratio, it is expected that they would behave similarly.

Considering the compressive strength results, all the concrete mixtures designed in this work met the design criteria (i.e. 25 or 35 MPa at 28 days). Moreover, slightly higher values were found for better-packed skeletons compared to materials with lower packing density, which seems to demonstrate that although Abrams' Law is the most critical factor controlling the compressive strength of conventional concrete, better packing can further improve its performance. Moreover, better-packed mixtures seemed to gain strength somewhat faster than less packed materials, especially in 35 MPa mixtures.

Another interesting point to consider here is the amount of cement. Even though not directly related to strength, cement content of conventional concrete mixes currently used in the market is very high. Furthermore, there is a misconception in the construction industry that cement brings mechanical properties in conventional concrete. Although preliminary, the previous results seem to indicate that LCC systems could be used to achieve conventional strengths for structural concrete, especially with the use of packed systems through PPMs.

Considering the flexural strength results, PPM mix- designed concrete presented superior results (i.e. modulus of rupture) compared to conventional methods. This is a particularly important output since flexural strength (or tensile strength) measurements in general indicates the ability of a given mixture to control first cracking and then crack spreading. Hence, better packed mixes with reduced amount of cement showed higher ability of cracking control compared to conventional mixtures.

The results obtained through the SDT were also quite positive. Maybe the most interesting parameter significantly improved by PPMs was the modulus of elasticity. Concrete mixes with higher q-values (i.e. higher content of coarse aggregate) presented much higher values of modulus of elasticity for both concrete types. Surprisingly, even 25 MPa mixtures PPM mix- designed with q3 showed greater modulus of elasticity than 35 MPa conventionally mix- designed or PPM mix- designed with q1. The results showed actually to be quite close to 35 MPa mixes PPM designed with q2. This seems to emphasize the influence of packing and amount of aggregates on the overall stiffness of granular systems such as concrete. Once more, the use of systems with low cement content did not negatively impact the overall rigidity of the material. On the other hand, SDI and PDI indices did not show any distinction as a function of packing density of the mixtures, which likely highlights that the cyclic and mechanical test is not precise enough to capture small changes

in concrete microstructure due to variations on the packing density. Nevertheless, all the SDI and PDI values obtained were lower than the threshold considered to be “negligible amount of damage” (i.e. SDI & PDI values lower than 0.11-0.12) as per Sanchez et al. [25], which indicates their suitable overall quality.

- *Durability-related properties*

The two NDT methods used in this research program (i.e., internal and surface electrical resistivity) agreed upon their results. It was found that higher packing density materials were observed to have more significant ER than less packed mixes. Additionally, the 25 MPa q3 mix reached, even with a considered very high w/c ratio, comparable results to the 35 MPa mix designed through the conventional ACI method.

Since all the concrete materials present the same w/c ratio (considering 25 and 35 MPa separately), it can be claimed that the resistivity was greatly influenced by the amount of binder (PC or even cement paste content), a phase which presents higher porosity and permeability than the aggregates skeleton, especially in conventional mixtures such as the ones studied in this work. Moreover, it is assumed in the literature that the lower the porosity and the higher the pore network tortuosity, the higher the ER [29]. It seems then that higher pores network tortuosity might have been achieved with better packing, which led to higher ER results. Therefore, the results seem to demonstrate that long-term durability, especially in cases related to transport mechanisms, would be positively affected by the use of well-packed LCC mixtures.

It is worth noting that the concrete pore solution composition can also influence ER results. It has been found that during the hydration process, the ionic composition of the pore solution changes. Ions such as OH^- , SO_4^{2-} , Na^+ , K^+ and Ca^{2+} are often released in the pore solution, which may decrease ER results since the ions mobility is facilitated [24]. Hence, it is anticipated that mixtures

designed through PPMs, especially the ones presenting reduced amount of binder and thus less ions exchange in the pore solution, will present higher ER values which may increase their performance regarding durability-related properties.

Optimizing the behaviour of concrete mixtures: a key point

In the previous sections, discussion was performed on the influence of PPMs and binder content on the fresh and hardened properties of concrete. It is clear that a number of parameters might interfere in the short and long term properties of concrete, such as the water-to-cement ratio (which is directly related to the material's porosity), as well as packing density, amount of fine particles (i.e. $< 100 \mu\text{m}$), etc. However, analyzing the previous sections, it seems that there is still a key point missing to fully characterize the behaviours found, or in other words, a physical parameter able to explain the fresh and hardened state results obtained using PPM with different q factors.

According to De Larrard [28], the w/c ratio has been widely used as a tool for a comprehensive description of the compressive strength of conventional concrete mixtures. However, only this parameter is not precise enough to predict the properties of concrete with especial features (i.e. LCC concrete, high performance concrete, roller compacted concrete, etc.) and thus a new parameter must be introduced in this regard.

De Larrard [28] defined two physical properties that might be of interest in LCC concrete: the maximum paste thickness (MPT) and the inter-particle spacing (IPS) parameter, where the MPT is the maximum distance between aggregate particles (i.e. particles greater than $100\text{-}150 \mu\text{m}$ when the fine aggregates are considered, or even greater than 4.75 mm when only the coarser particles are accounted). IPS determines the maximum distance between fine particles (aggregates less than $100\text{-}150 \mu\text{m}$) [30]. De Larrard and Belloc claimed that in conventional concrete with high concentrated granular systems (such as the ones designed with PPMs), the mechanical properties

of the material may be governed by the distance between the coarse aggregate particles which, according to them, might be imagined as mini- test specimens submitted to uniaxial compressive loads, where the aggregates at the top and bottom would be the test frame platens (Figure 3.21). IPS would act physically the same as MPT, yet it might be primarily linked to the fresh state behaviour of LCC concrete.

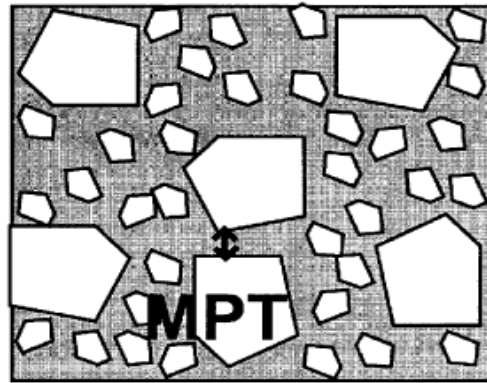

(b)

Figure 3.21: Concrete as a dry packing with cement paste [28].

In this work, MPT was determined according to [28] (Equation 3.2) and its influence on the different hardened state concrete properties was evaluated and compared with the different mix-designs used in this research.

$$MPT = D_{max} \left(\sqrt[3]{\frac{g^*}{g}} - 1 \right) \dots\dots\dots(3.2)$$

where D_{max} is the maximum aggregate size, g is the aggregate volume in a unit volume of concrete, which can be easily derived from the mixture proportioning, and g^* can be calculated by means of Equation 3.3,

$$g^* = 1 - 0.47 \sqrt[5]{\frac{D_{min}}{D_{max}}} \dots\dots\dots(3.3)$$

where D_{min} is the minimum sized aggregate corresponding to 10% passing, and D_{max} is the maximum sized aggregate corresponding to 90% passing. Moreover, to evaluate the different distribution factors (q values) on the most extensive scale possible, the MPT used was the one based on a 5 mm coarse aggregate particle; i.e. the one that yields the highest paste thickness possible in the system. Figure 3.22 illustrates the comparison between MPT and the hardened state parameters of concrete for the 25 and 35 mixes studied.

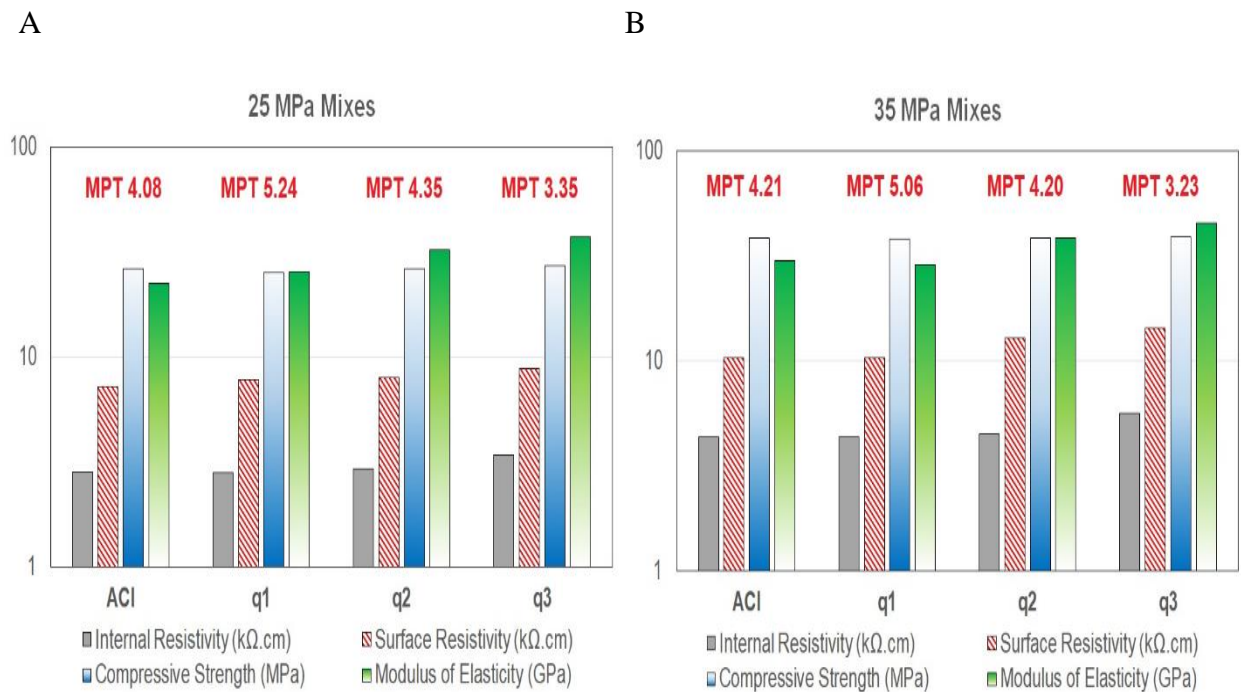

Figure 3.22: Comparison between hardened state properties and MPT for A) 25 MPa and B) 35 MPa concrete mixes.

Analyzing the results one notices that as soon as the distribution factor increases (q -value), the system becomes denser, which lessens the overall number of voids and thus decreases the binder amount required. Therefore, MPT seems to be a key parameter for controlling important hardened state and long-term properties of conventional concrete, since the higher the distribution factor, the lower the MPT, the higher the compressive strength, modulus of elasticity and electrical resistivity (both internal and surface) for both 25 and 35 MPa mixtures. However, it is important

to mention that as MPT lessens, the system’s flowability also decreases and the system presents higher viscosity. These results seem to demonstrate that the distance between particles might govern several of the hardened state properties of high concentrated granular systems such as concrete.

Eco-efficiency of concrete mixtures

The relationship between climate changes and CO₂ emissions has been very well established, and the PC industry is one of the most contributors regarding the carbon footprint of civil construction. Improving the efficiency of PC’s use is one of the most important strategies for reducing CO₂ emissions. Such approach could result in an overall 15% reduction in cement consumption by the year 2050 [32]. In that context, it has been suggested that a performance indicator might developed to understand and quickly estimate PC efficiency in concrete, which would also help to produce a benchmark, since there is little to no discussion in the literature on that matter [31].

Damineli [32] proposed an index accounting for PC efficiency, the so-called *Binder Intensity Index* (*bi*), which is defined as the amount of PC required to obtain 1 desired unit of a given concrete; e.g. the amount of PC in kg/m³ to obtain 1 MPa of compressive strength at a given time (i.e., 28 days). (Equation 3.4).

$$bi = \frac{B}{CS} \dots\dots\dots (3.4)$$

where, *bi* is binder intensity index (in kg/m³.MPa), *B* is the binder amount (in kg/m³) and *CS* is the compressive strength in MPa. It is worth noting that the *bi* factor may be used as an indicator of a number of concrete properties other than compressive strength. Damineli et al benchmarked the relationships between the binder intensity index (*bi*) and the compressive strength of concrete mixtures used in Brazil and around the globe. The authors noticed that the higher the compressive

strength, the lower the bi factor. In other words, high strength concrete mixtures implicitly have low bi indices or even lower carbon footprint. However, high to very high bi factors are obtained in CC mixtures used in civil infrastructure (i.e. from 20 to 40 MPa), which are the most frequent concrete-type classes used worldwide. In order to assess how eco-friendly the mixtures evaluated in this work were, the bi factors were calculated for all of them and the results were located in Figure 3.23 for 25 and 35 MPa mixes.

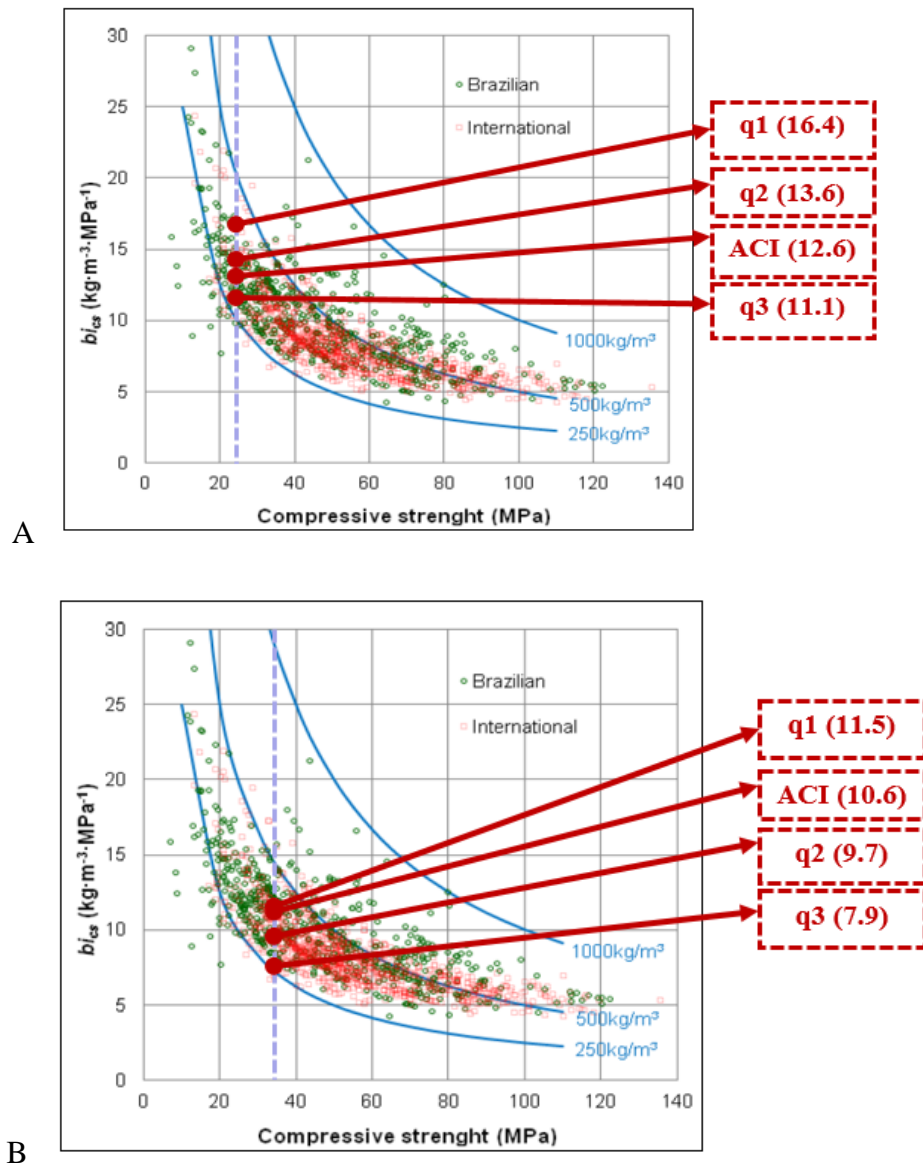

Figure 3.23: Comparison between binder intensity factor and compressive strength for A) 25 MPa and B) 35 MPa concrete mixes [2].

Looking at the above plots, it seems that the use of continuous PPMs could be a way of lowering cement in CC, since the higher the packing density (and the q value), the lower the bi factor obtained. While ACI mixes presented 12.6 and 10.6 as bi factors for 25 and 35 MPa mixes, respectively, $q3$ mixes reached considerably lower values (11.1 and 7.9 respectively), with $q3$ being considered a LCC mix (i.e. binder content lower than 335 kg/m^3 as per ACI 302 [33]). These results are very encouraging, particularly considering that the mixtures were intentionally designed without the use of chemicals, fillers or even SCMs, which leaves a room for improvements leading to further decreases in cement content, and consequently bi factor, for PPM mix- designed mixes.

Modelling and forecasting concrete properties

Modeling and forecasting behaviour is the ultimate goal of experimental research. Response surface methodology (RSM) is a collection of statistical and mathematical techniques useful for understanding, developing, improving and optimizing processes. RSM aims to optimize a response (output variable) which is influenced by several independent variables (input variables), by careful design of experiments [34]. In this work, two level factorial designs (i.e. 2D RSM analysis) were built through the evaluation of two independent factors from the experimental data gathered within this research. The two independent factors selected for studying were MPT and the water-to-cement ratio. These two factors were parametrized as a function of independent outcomes such as modulus of elasticity, surface ER and binder efficiency. These models were generated to forecast the influence of MPT and water to cement ratio in mechanical, long term and sustainable performance of concrete mixtures

Figure 3.24 illustrates the relationship between surface ER, modulus of elasticity and bi factor as a function of MPT and w/c . All the plots show linear relationships with the MPT for all mixtures.

The higher the MPT (maximum paste thickness), the higher the bi factor and the lower the surface ER and modulus of elasticity. Moreover, it can be seen as the w/c increases, the slope of the curve becomes steeper, which means the higher the packing density, the higher the surface ER and modulus of elasticity. This analysis shows that the use of highly packed mixes is essential not only for reducing the amount of cement but rather to improve the long term performance of CC mixes (i.e. Increasing mechanical properties and reducing the transport mechanisms through the material). Finally, these models highlight once more the misconception of linking “mechanical strength and performance” to “binder content”, especially while the use of PPMs.

A)

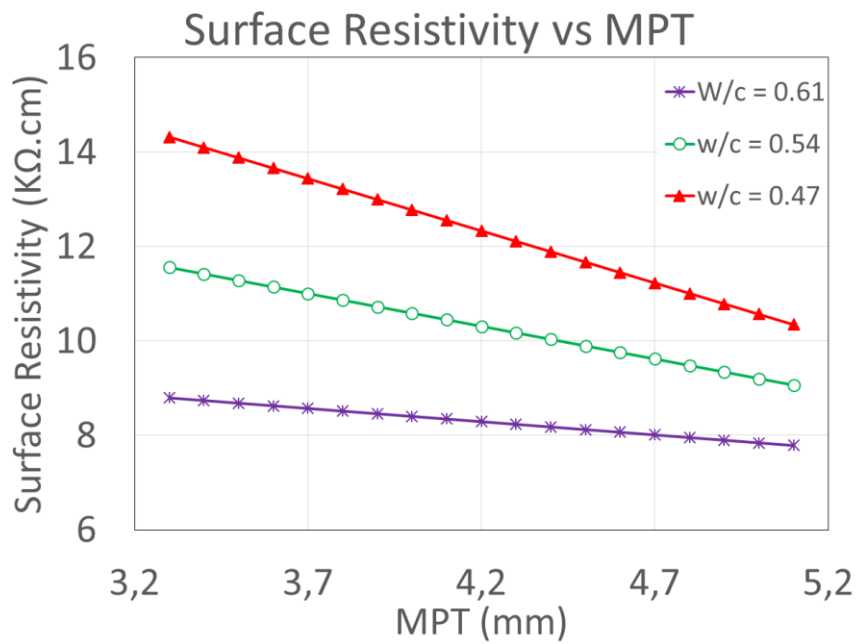

B)

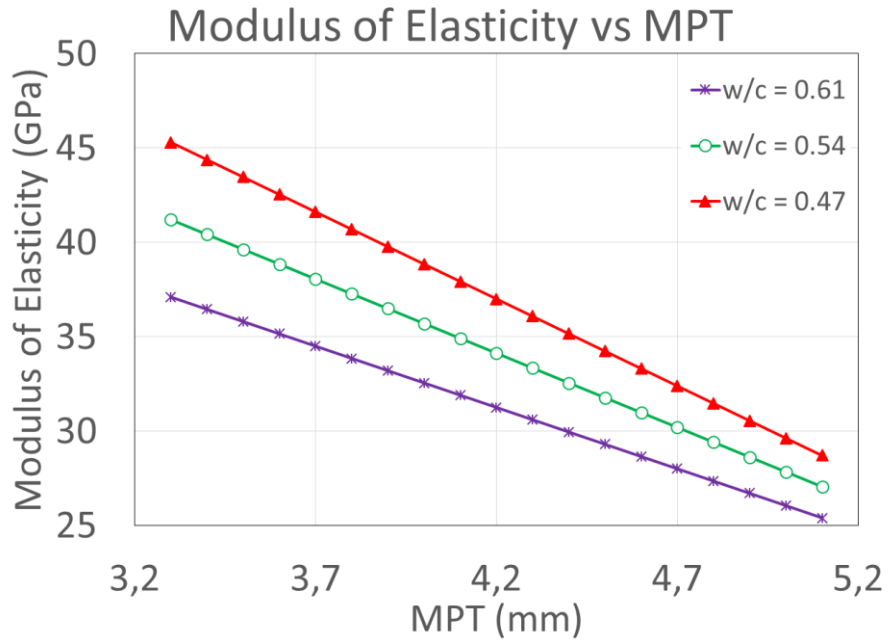

C)

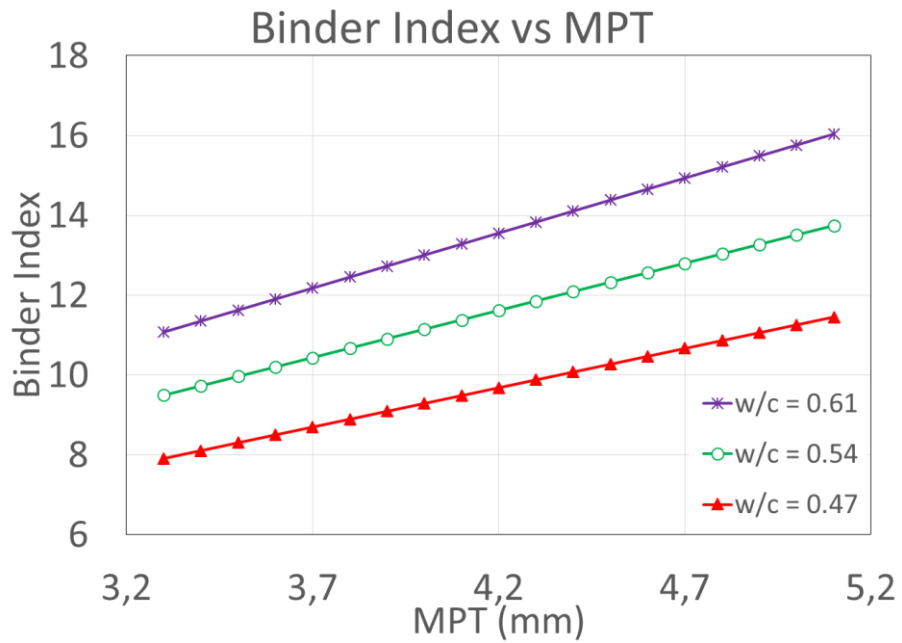

Figure 3.24: Modeling the behaviour of concrete as a function of MPT and water-to-cement ratio.

3.1.7 CONCLUSIONS

This project aimed to evaluate and quantify the behaviour of concrete mixtures designed with the use of continuous PPMs to increase binder efficiency in concrete. Three q factors were selected in this research and properties in the fresh and hardened states were measured and analyzed. The main conclusions on the above investigations are:

- The use of PPMs showed capability of improving the hardened state (i.e. compressive strength, modulus of elasticity, bending flexure) and durability related (resistivity) properties of conventional concrete mixtures.
- Abrams' Law, although a critical parameter that sets the mechanical properties of conventional concrete (i.e. compressive strength), does not seem to be able to further explain the different performances obtained by PPM designed mixtures with different q values. The MPT showed to be a key parameter in differentiating the hardened state behaviour of mixtures with distinct packing degrees though and should be further investigated.
- PPMs seems to enable the development of LCC systems with remarkable performance and low b_i factors. Further research is still needed to confirm these preliminary results.
- Particular attention should be taken in very well-packed mixtures in the fresh state, since very low consistency (i.e. close to zero slump) may be achieved. The latter is expected to be highly improved while the use of fillers, chemical admixtures and/or SCMs.

3.1.8 ACKNOWLEDGEMENTS

The authors would like to thank Mr. Muslim Majeed and Gamal Elnabelsya Thomassin from the Materials and Structural laboratory at uOttawa, as well as the post-doc, graduate and undergraduate research assistants who helped with the manufacturing and testing of the test specimens used in

this project. We also would like to acknowledge the generous help from *Ciment Québec* and *Lafarge Canada Inc.* for providing this research with cement and aggregates. Special thanks to *Giatec* for providing this research with the SmartBox devices and to Mr. Andre Demers from Natural Resources Canada (CANMET) for his support and help throughout this work.

3.1.9 REFERENCES

- [1] Battele. 2002. *Climate Change: Toward a Sustainable Cement Industry*. Richland, Washington, United States.
- [2] Damineli, B. L.; Kemeid, F. M., Aguiar, P. S. and John, V. M. "Measuring the eco-efficiency of cement use," *Cement & Concrete Composites*, pp. 555-562, 2010.
- [3] Mangulkar, M., and Jamkar, S. "Review of Particle Packing Theories Used for Concrete Mix Proportioning," *International Journal of Scientific and engineering Research Volume-4*, pp. 143-148, 2013.
- [4] Popovics, S. "History of mathematical model for strength development of Portland cement concrete," *ACI Materials Journal*, Vol. 95 (5), pp. 593-600. , 1998.
- [5] Fuller, W. B. and Thompson, S. E. "The Laws of Proportioning Concrete," *American Society of Civil Engineers*, Vol.33, pp. 223-298, 1907.
- [6] Brouwers, H. and Radix, H. "Self-compacting concrete: the role of the particle size distribution," *First International Symposium on Design*, pp. 109-118, Changsha, China (2005).
- [7] Dinger, D. R. and Funk, J. E., "Particle-Packing Phenomena and Their Application in Materials Processing," *MRS Bulletin*, v. 22, 12, 1997, pp. 19-23.
- [8] Fennis, S. A. and Walraven, J. C. "Using particle packing technology for sustainable mixture design," *HERON Vol. 57 No. 2* , pp. 73 - 102, 2012.

- [9] Fruhstofer J. and Aneziris, C. "The influence of Coarse Fraction on the Porosity Refractory Castables," *Journals of Ceramic Science and Technology*, pp. 155-165, 2014.
- [10] Vogt, C. "Ultrafine particles in concrete: Influence of ultrafine particles on concrete properties and application to concrete mix design," Stockholm, Sweden: Royal Institute of Technology, School of Architecture and the Built Environment, 2010.
- [11] ASTM Standard C 128-15, Standard Test Method for Relative Density (Specific Gravity) and Absorption of Fine Aggregate, West Conshohocken, PA 19428-2959: ASTM International, 2015.
- [12] ASTM Standard C 127-15, Standard Test Method for Relative Density (Specific Gravity) and Absorption of Coarse Aggregate, West Conshohocken, PA 19428-2959: ASTM International, 2015.
- [13] Kosmatka, S.H.; Kerkhoff, B. and Panarese W. C. "Design and Control of Concrete Mixtures," Portland Cement Association, 2012.
- [14] Abrams, D. A., Design of Concrete Mixtures, Lewis Institute, Structural Materials Research Laboratory, Bulletin No. 1, PCA LS001, Chicago, http://www.cement.org/pdf_files/LS001.pdf, 1918, 20 pages.
- [15] ASTM Standard C 136-01, Standard Test Method for Sieve Analysis of Fine and Coarse Aggregates, West Conshohocken, PA 19428-2959: ASTM International, 2001.
- [16] ASTM Standard C192/C192M-16a, Standard Practice for Making and Curing Concrete Test Specimens in the Laboratory, West Conshohocken, PA 19428-2959: ASTM International, 2016.
- [17] ASTM C78/C78M-16 Standard Test Method for Flexural Strength of Concrete (Using Simple Beam with Third-Point Loading), West Conshohocken, PA 19428-2959: ASTM International, 2002.

- [18] ASTM C143/C143M-15a Standard Test Method for Slump of Hydraulic-Cement Concrete, West Conshohocken, PA 19428-2959: ASTM International, 2016.
- [19] ASTM C231/C231M-17a Standard Test Method for Air Content of Freshly Mixed Concrete by the Pressure Method, West Conshohocken, PA 19428-2959: ASTM International, 2017.
- [20] ASTM Standard C138/C138M - 17a, Standard Test Method for Density (Unit Weight), Yield, and Air Content (Gravimetric) of Concrete, West Conshohocken, PA 19428-2959: ASTM International, 2017.
- [21] ASTM C39/C39M-17b, Standard Test Method for Compressive Strength of Cylindrical Concrete Specimens, West Conshohocken, PA 19428-2959: ASTM International, 2016.
- [22] Morris, W.; Moreno, E.I. and Sagües, A.A. “Practical evaluation of resistivity of concrete test,” *Cement and Concrete Research*, Vol. 26, No. 12, pp. 1779-1787, 1996.
- [23] Proceq. (2017). Resipod Family: Operating Instructions - Concrete Durability Testing. Retrieved from www.proceq.com.
- [24] Tomlinson, D.; Moradi, F.; Hajiloo, H.; Ghods, P.; Alizadeh, A.; Green, M. “Early age electrical resistivity behaviour of various concrete mixtures subject to low temperature cycling,” *Cement and Concrete Composites* 83 (2017) 323-334.
- [25] Sanchez, L. F. M., Fournier, B., Jolin, M, Bastien, J., Mitchell, D. Overall assessment of alkali-aggregate reaction (AAR) in concretes presenting different strengths and incorporating a wide range of reactive aggregate types and natures. *Cement and Concrete Research*, vol. 93, 17-31, 2017.
- [26] Walsh, J.B. The Effect of Cracks on the Uniaxial Elastic Compression of Rocks. *Journal of Geophysical Research*, vol. 70, no. 2, pp. 399-411, 1965.

- [27] L.F.M. Sanchez, B. Fournier, M. Jolin, J. Bastien, Evaluation of the Stiffness Damage Test (SDT) as a tool for assessing damage in concrete due to ASR: test loading and output responses for concretes incorporating fine or coarse reactive aggregates, *Cem. Concr. Res.* 56 (2014) 213–229.
- [28] De Larrard, F. and Belloc, A. (1997) The influence of aggregate on the compressive strength of normal and high-strength concrete. *ACI Materials Journal*, 94(5), 417–426..
- [29] Riding, K.A., Poole, J.L., Schindler, A.K., Juenger, M.G., and Folliard, K.J., “Simplified Concrete Resistivity and Rapid Chloride Permeability Test Method,” *ACI Materials Journal*, Vol. 105, No. 4, pp. 390-394, 2008.
- [30] P. Bonadia, A. R. Studart, G. R. Pileggi and S. L. Vendrasco, "Applying MPT principle to high-alumina castables," *American Ceramic Society Bulletin*, vol. 78, pp. 57-60, 1999.
- [31] Damineli, B. L., Kemid, F., Aguiar, P., John, V. Measuring the eco-efficiency of cement use. *Cement and Concrete Composites*, 32 (2010) 555-562.
- [32] B. L. Damineli, R. G. Pileggi and V. M. John, "Lower binder intensity eco-efficient concrete," Woodhead Publishing Limited, Sao Paulo, Brazil, 2013.
- [33] ACI Committee 302, Guide for Concrete Floor and Slab Construction, ACI 302.1R-15, American Concrete Institute, Farmington Hills, Michigan, 2015.
- [34] V. V. Toropov, L. F. Alvarez (1998). Application of genetic programming and response surface methodology to optimization and inverse problems. In: *Inverse problems in engineering mechanics* (551-560). Rotterdam.

CHAPTER 4

4.1 Conclusion & recommendations

4.1.1 Fresh state properties

The previous sections showed that the use of PPMs influence the fresh state behaviour of concrete mixtures. Data gathered in this work demonstrated that the higher the packing density, the higher the material consistency (or the lower the slump value). In other words, the lower the binder amount, the less the lubrication and the higher the friction among particles which decreases flowability. Moreover, the fresh state properties (i.e. consistency in this work) seems to be more influenced by PPMs in systems with lower amount of water (e.g. 35 MPa compared to 25 MPa) since water also acts as a lubricant and thus allows the binder reduction, causing less impact on the material's flow. Hence, the results previously presented indicate that although reduced cement systems (with higher packing density) demand less water to enable flow, the presence of much higher interaction forces (friction) among the aggregate particles looks like to be a limiting factor in systems with moderate amount of water. Consequently, particular consideration must be taken on the fresh state behaviour of LCC.

The density of concrete mixtures in the fresh state was also affected by the use of PPMs. Prior results highlighted that the higher the packing density, the higher the fresh density of concrete mixtures. The latter reinforces the idea that better packed concrete might then provide advantages on the long-term performance. Besides that, the density of the mixtures were not linked to the amount of binder used (actually it was the opposite) which may help to change the current misconception that LCC systems cannot be cohesive and/or durable enough due to the lack of binder.

4.1.2 Hardened state properties

Mechanical properties

Although Abrams' Law is very likely the most important aspect governing the mechanical properties (i.e. compressive strength) of conventional concrete, the results obtained in this research demonstrated that mechanical performance may be improved through the use of PPMs. Considering compressive strength, better-packed mixtures presented slightly higher values compared to lower packing density mixes over all ages. Moreover, better-packed microstructures presented faster strength gain in comparison with less packed materials, especially in 35 MPa mixes. Therefore, data gathered in this research helped to provide a better understanding on the misconception currently found in the market that the amount of binder is directly related to the mechanical properties of concrete mixtures.

Likewise, the performance of PPM mix- designed concrete in flexure (i.e. modulus of rupture) was significantly higher than concrete designed through conventional procedures. The latter is a particularly important outcome since flexural strength (or indirect tensile strength) measurements indicate the ability of a given material to control the nucleation and propagation of cracks. In other words, concrete with higher packing densities (and lower binder amounts) showed improved ability of controlling cracking when compared to conventional concrete.

Maybe the most exciting and promising results obtained in this research were the ones from the evaluation of the stiffness (i.e. modulus of elasticity) of the mixtures. High packing density mixes with higher amount of aggregates and lower cement content presented significantly higher modulus of elasticity results when compared to conventional concrete. Moreover, high packed mixtures with higher porosity (i.e. higher water-to-cement ratio) and thus lower mechanical

properties showed sometimes similar or greater stiffness values than lower packed mixtures with lower porosity. For example, 25 MPa PPM mix-designed mixtures with the highest packing density (ρ_3) showed greater modulus of elasticity than 35 MPa conventionally mix- designed mixtures. The prior results evidence the importance and effects of the amount of aggregates and PSD on the overall stiffness of granular systems such as concrete.

Durability-related properties

It is anticipated that better packed systems would present improved durability and long-term behaviour in the field. In this work, internal and surface electrical resistivity were used to evaluate the “potential” durability performance of concrete mix- designed with different packing densities. As most of the mechanical properties, results indicated that the higher the packing density, the higher the ER values obtained. Therefore, mixtures with higher amount of binder presented lower ER results very likely due to their higher cement paste content and overall porosity. Furthermore, high packed mixtures with higher porosity (i.e. higher water-to-cement ratio) presented sometimes similar ER values when compared to lower packed mixtures and lower porosity.

4.1.3 Optimizing concrete mixture behaviour

The results obtained throughout this research showed that only the water-to-cement ratio according to Abram’s law is not enough to distinguish the mechanical properties of mixtures with distinct packing densities. Therefore, the concept of maximum paste thickness (MPT) was introduced and used in the evaluation of the gathered results. Interestingly, systems thought to have roughly the same porosity (i.e. mixtures with the same water-to-cement ratio), and thus same mechanical and durability properties were found to distinguish themselves as a function of their MPT. Hence, the higher the MPT, the lower the mechanical and durability-related properties. Conversely, MPT also influenced the fresh state properties of concrete mixtures. Low MPT values decreased the cement

paste content in the mixes and their respective lubrication, which increased the friction among particles and reduced their flow.

4.1.4 Eco-efficiency of concrete mixtures

The binder intensity (bi) factor was assessed to provide a quantitative measure of the eco-efficiency of the concrete mixtures studied in this research. The bi values gathered for the distinct mixtures demonstrated that the use of PPMs is an effective tool to mix- proportion eco-friendly concrete mixtures with suitable performance in the fresh and hardened states, since values close to the bottom line proposed by Daminieli et al (2010) were found. Nevertheless, it is worth noting that the bi factors obtained might have been even lower while the use of chemical admixtures and supplementary cementing materials (SCMs).

4.1.5 Modelling and forecasting concrete properties

Response Surface Methodology (RSM) is known as a valuable tool for understanding, developing, improving and optimizing processes within a given range of values selected by the designer. In this work, RSM was used to forecast fresh and hardened state behaviours of concrete mix-designed through PPMs. Two independent factors (MPT and water-to-cement ratio) were selected to produce 2D RSM plots, which were quite helpful to forecast targeted behaviours within the range of values used in this work. With these models in hand, designers might select parameters for PPMs mix- designed concrete without the need of their full characterization and testing in the laboratory. The results gathered through the use of RSM not only highlighted the conclusions prior discussed in the above sections but also helped to make even clearer the current market misconception that links “mechanical strength and performance” of concrete mixtures to their “binder content”, especially while the use of PPMs.

4.1.6 Future Works

While this Thesis has demonstrated that the hardened state and durability related properties of concrete mixtures may be largely improved by the use of PPMs, a number of research opportunities have arisen from the results and discussion performed. This section highlights some of these possibilities as presented hereafter:

- Particular attention should be given to the fresh state behaviour of PPM mix- designed concrete. Thus, opportunities of understanding the influence of chemical admixtures (e.g. water reducers), supplementary cementing materials (SCMs) and fillers on the overall rheological behaviour of highly packed systems with reduced cement content is still an open task;
- Special attention should also be given to the durability (i.e. freeze-thaw, alkali-aggregate reaction, sulfate attack, carbonation and chloride penetration, etc.) and long-term performance (i.e. fatigue, creep, etc.), of PPM mix-designed concrete incorporating (or not) SCMs and fillers. The influence of packing density on durability-related problems is still uncertain;
- While the use of continuous PPMs such as Alfred model was found to be effective in designing concrete mixtures with reduced binder content, there is still room for improving the current continuous PPM mix- design approach, perhaps “breaking” the curve into distinct phases and providing a “gap-graded” PSD to the system;
- Finally, the structural behaviour of conventional concrete with reduced amount of cement was barely investigated and should be further assessed.

CHAPTER 5

5.1 References

- Abrams, D. A. (1920). Design of concrete mixtures. Chicago, USA: Structural Materials Research Laboratory, Lewis Institute.
- ACI Committee 302, Guide for Concrete Floor and Slab Construction, ACI 302.1R-15, American Concrete Institute, Farmington Hills, Michigan, 2015.
- Addis, B., & Alexander, M. (1994). Cement-Saturation And Its Effects On The Compressive Strength And Stiffness Of Concrete. Cement and Concrete Research, Vol. 24, No. 5, 975-986.
- Alsadey, S. (2012). Influence of Superplasticizer on Strength of Concrete. International Journal of Research in Engineering and Technology (IJRET), 164-166.
- ASTM. (2001). ASTM Standard C 136-01:Standard Test Method for Sieve Analysis of Fine and Coarse Aggregates. West Conshohocken, PA 19428-2959, United States: ASTM International.
- ASTM. (2002). ASTM Standard C78/C78M-16: Standard Test Method for Flexural Strength of Concrete (Using Simple Beam with Third-Point Loading). West Conshohocken, PA 19428-2959, United States: ASTM International.
- ASTM. (2015). ASTM Standard C 127-15: Standard Test Method for Relative Density (Specific Gravity) and Absorption of Coarse Aggregate. West Conshohocken, PA 19428-2959, United States: ASTM International.
- ASTM. (2015). ASTM Standard C 128-15: Standard Test Method for Relative Density (Specific Gravity) and Absorption of Fine Aggregate. West Conshohocken, PA 19428-2959, United States: ASTM.
- ASTM. (2016). ASTM Standard C143/C143M-15a: Standard Test Method for Slump of Hydraulic-Cement Concrete. West Conshohocken, PA 19428-2959, United States: ASTM International.
- ASTM. (2016). ASTM Standard C192/C192M-16a: Standard Practice for Making and Curing Concrete Test Specimens in the Laboratory. West Conshohocken, PA 19428-2959, United States: ASTM International.
- ASTM. (2016). ASTM Standard C39/C39M-17b: Standard Test Method for Compressive Strength of Cylindrical Concrete Specimens. West Conshohocken, PA 19428-2959: ASTM International.
- ASTM. (2017). ASTM Standard C138/C138M - 17a: Standard Test Method for Density (Unit Weight), Yield, and Air Content (Gravimetric) of Concrete. West Conshohocken, PA 19428-2959, United States: ASTM International.

- ASTM. (2017). ASTM Standard C231/C231M-17a: Standard Test Method for Air Content of Freshly Mixed Concrete by the Pressure Method . West Conshohocken, PA 19428-2959, United States: ASTM International.
- ASTM Standard D6910/D6910M-09. (2009). West Conshohocken, PA: ASTM International, USA.
- Barnes, H., Hutton, J., & Walter, K. (1989). An Introduction to Rheology. Amsterdam, The Netherlands: Elsevier Science.
- Bizinotto, M. B., Faleschini, F., Fernández, C. G., & Hernández, D. F. (2017). Effects of chemical admixtures on the rheology of fresh recycled. *Construction and Building Materials*, 353-362.
- Bonadia, P., Studart, A., Pileggi, G., & Vendrasco, S. (1999). Applying MPT principle to high-alumina-castables. *American Ceramic Society Bulletin*, Vol. 78, 57-60.
- Brouwers, H., & Radix, H. (2005). Self-compacting concrete: the role of particle size distribution. *First International Symposium on Design, Performance and Use of Self-Consolidating Concrete*, (pp. 109-118). Changsha, Hunan, China.
- Castro, A. L., Liborio, J. B. L., Pandolfelli, V. C. (2009) Performance of advanced concretes for building site designed by computing mix proportion technique. *Ceramica*, Vol. 55, 233-251.
- Castro, A. L., Liborio, J. B. L., Pandolfelli, V. C. (2011) The influence of cement type on the performance of advanced concretes designed by computing mix proportion technique. *Ceramica*, Vol. 57, 10-21.
- Castro, A. L., & Ferreira, F. (2016). Effect of particle packing in the durability of high performance concretes. *Revista Ingeniería de Construcción*, Vol. 31, 91-104.
- Crisp, T., Waldron, P., & Wood, J. (1993). Development of a non destructive test to quantify damage in deteriorated concrete. *Magazine of Concrete Research*, Vol. 45 (165), 247-256.
- Dameneli, B. L., Pileggi, R. G., & John, V. M. (2013). Lower binder intensity eco-efficient concrete. Woodhead Publishing Limited, San Paulo, Brazil.
- Dameneli, B., Pileggi, R., & John, V. (2017). Influence of packing and dispersion of particles on the cement content of concretes. *Bracon Structures and Material Journal*, 998-1010.
- Dameneli, B., Kemid, F., Aguiar, P., & John, V. (2010). Measuring the eco-efficiency of cement use. *Cement & Concrete Composites*, Vol 32, 555-562.
- Dat, W. K. (1999). *Concrete Mix Design, Quality Control and Specification*, Second Edition. New York, USA: E & FN.
- De Larrard, F., & Belloc, A. (1997). The Influence of Aggregate on the Compressive Strength of Normal- and High-Strength Concrete. *ACI Materials Journal*, Vol. 94, 418-425.

- De Larrard, F., & Sedran, T. (1994). Optimization of ultra-high performance concrete by the use of a packing model. *Cement and Concrete Research*, Vol. 24, 997-1009.
- De Larrard, F., & Tondat, P. (1993). Sur la contribution de la topologie du squelette granulaire à la résistance en compression du béton. *Materials and Structures*, 505–516 .
- Dinger, D., & Funk, J. (1997). Particle-Packing Phenomena and Their Application in Materials Processing . *MRS Bulletin*, Vol. 22 (12), 19-23.
- Fennis, S., & Walraven, J. (2012). Using particle packing technology for sustainable concrete mixture design. *HERON* Vol. 57, 73-101.
- Franca, M.S., Cardoso, F.A., Pileggi, R.G. (2016) Influence of the addition sequence of PVA-fibers and water on mixing and rheological behavior of mortars. *Ibracon Structures and Materials Journal*. Vol. 9 (2), 226-243.
- Frushtofer, J., & Aneziris, C. (2014). The Influence of Ultrafine Particles on the Porosity Refractory Castables. *Journals of Ceramic Science and Technology*, 155-165.
- Fuller, W. B., & Thompson, S. (1907). The Laws of Proportioning Concrete. *American Society of Civil Engineers*, Vol. 33, 223-298.
- Geotechnics. (21 de 12 de 2017). GEOTECHNICS. Fonte: www.geotechnics.co.nz:
<https://www.geotechnics.co.nz/buy/laboratory-4/marsh-funnel-viscometer/>
- Goltermann, P., Johansen, V., & Palbol, L. (1997). Packing of aggregates: an alternative tool to determine the optimal aggregate mix. *ACI Material Journal*, Vol.94, 435-443.
- Hearn, N., Hooton , D., & Nokken, M. (2006). Pore Structure, Permeability, and Penetration Resistance Characteristics of Concrete. *Em West, Significance of tests and properties of concrete and concrete-making materials* (pp. 238-252). West Conshohocken/PA, USA: ASTM International.
- House, T. A. (21 de 12 de 2017). The Anchor House. Fonte: www.theanchorhouse.com:
http://www.theanchorhouse.com/?essential_grid=crushing-grinding
- Humphreys, K., Mahasenan, M., Placet, M., & Fowler, K. (2002). *Climate Change: Towards a Sustainable Cement Industry*. Washington, USA: World Business Council for Sustainable Development .
- Kosmatka, S., Kerkhoff, B., & Panarese, W. (2012). *Design and Control of Concrete Mixtures*. Cement Association of Canada.
- Kumar, S., & Santhanam, M. (2003). Particle packing theories and their application in concrete mixture proportioning: A review. *Indian Concrete Journal*. Vol 77, 1324-1331.
- Layssi, H., Ghods, P., Alizadeh, A., & Salehi, M. (May de 2015). Electrical Resistivity of Concrete: Concepts, applications, and measurement techniques. *Concrete International Magazine* , pp. 41-46.

- LEUTERT. (21 de 12 de 2017). LEUTERT. Fonte: <https://www.leutert.com>:
<https://www.leutert.com/cement-mud-testing/en/products/marsh-funnel.php?lang=EN>
- Li, D., Li, L.-y., Wang, X., & Xing, F. (2017). A double-porosity model for water flow in unsaturated concrete. *Applied Mathematical Modelling*, Vol. 53, 510-522.
- Liu, Y., & Presuel-Moreno, F. (2014). Normalization of Temperature Effect on Concrete Resistivity by Method Using Arrhenius Law. *Aci Materials Journa*, Vol.111, 433-442.
- Machinery, X. M. (21 de 12 de 2017). Xingyang Mining Machinery. Fonte: www.ore-processing.com: <http://www.ore-processing.com/processing-equipment/ceramic-ball-mill.html>
- Mangulkar, M., & Jamkar, S. (2013). Review of Particle Packing Theories Used for Concrete MixProportioning. *International Journal of Scientific and engineering Research Volume-4*, 143-148.
- Mehdipour, I., & Khayat, K. (2017). Understanding the role of particle packing characteristics in rheophysical properties of cementitious suspensions: A literature review. *Construction and Building Materials*, Vol. 161, 340-353.
- Mehta, P.K., Monteiro, P.J.M. (2005). *Concrete*, New York: McGraw-Hill Professional, 660 p.
- Morris, W., Moreno, E., & Sagües, A. (1996). Pratical evaluation of resistivity of concrete test. *Cement and Concrete Research*, Vol. 26, No. 12, 1779-1787.
- Morris, W., Vico, A., Vazquez, M., & de Sanchez, S. (2002). Corrosion of reinforceing steel Eavluated by means of concrete resistivity measurements. *Corrosion Science*, Vol. 44, 81-99.
- Morrison, F. A. (2004). What is Rheology? *The Industrial Physicist* Vol. 10, 29-31.
- Neville, A. M. (2011). *Properties of Concrete*, 5th edition. London, UK: Pitman Publishing Co.
- Oliveira, C.A., Maciel, G.F., Castro, A.L., Barbosa, M.P, Campos, R.S. (2018). Impact of particle packing concept on dosage of high performance concrete. *Revista Materia*, Vol.23 (1), 1-15.
- Oliveira I. R., Studart A. R., Pileggi R. G. and Pandolfelli V.C. (2000), *Dispersão e empacotamento de partículas: princípios e aplicações em processamento cerâmico*, São Paulo: Fazenda Arte Editorial, 224 p.
- Pileggi, R. G., Pandolfelli, V. C., Paiva, A. E., Gallo, J. B. (2000), Novel rheometer for refractory castables, *Am. Ceram. Soc. Bull.*, Vol. 79 (1), 54-58.
- Popovics, S. (1998). History of mathematical model for strength development of Portland cement concrete. *ACI Materials Journal*, Vol. 95 (5), 593-600.
- Powers, T. (1968). *The Properties of Fresh Concrete*. New York, USA.: John Wiley.

- Proceq. (30 de 12 de 2017). *Corrosion potential, concrete resistivity and permeability testers*. Source: [www.proceq.com: https://www.proceq.com/compare/corrosion-potential-concrete-resistivity-and-permeability/](https://www.proceq.com/compare/corrosion-potential-concrete-resistivity-and-permeability/)
- Ramachandran, V. S. (2000). *Concrete Science. In: Analytical Techniques in Concrete Science and Technology*. Noyes Publications.
- Ramachandran, V., & Feldman, R. (1995). *Concrete Admixtures Handbook: Properties, Science and Technology*. New Jersey, USA: Noyes Publications.
- Riding, K. P. (2008). Simplified Concrete Resistivity and Rapid Chloride Permeability Test method. *ACI Journal, Vol. 105 (4)*, 390-394.
- Roquier, G. (2016). The 4-parameter Compressible Packing Model (CPM) including a new theory about wall effect and loosening effect for spheres. *Powder Technology, Vol. 302*, 247–253
- Roussel, N., & Le Roy, R. (2004). The Marsh cone: a test or a rheological apparatus? *Cement and Concrete Research*, 1-8.
- Sanchez, L. F., Fournier, B., Jolin, M., & Bastien, J. (2015). Evaluation of the Stiffness Damage Test (SDT) as a tool for assessing damage in concrete due to alkali-silica reaction (ASR): Input parameters and variability of the test responses. *Construction and Building Materials, Vol. 77*, 20-32.
- Sanchez, L., Fournier, B., & Jolin, M. (2012). Study of the parameters of the Stiffness Damage Test (SDT) for assessing concrete structures damaged due to alkali-silica reaction (ASR). *International Conference on Alkali-Aggregate Reaction (ICAAR)*. Texas, USA: ResearchGate.
- Sanchez, L., Fournier, B., Jolin, M., & Bastien, J. (2014). Evaluation of the Stiffness Damage Test (SDT) as a tool for assessing damage in concrete due to ASR: test loading and output responses for concretes incorporating fine or coarse reactive aggregates. *Cement and Concrete Research, Vol. 56*, 213–229.
- Sanchez, L.F.M., Fournier, B., Jolin, M., Bastien, J., Mitchell, D. (2016). Practical use of the Stiffness Damage Test (SDT) for assessing damage in concrete infrastructure affected by alkali-silica reaction. *Construction and Building Materials, Vol. 125*, p. 1178–1188.
- Sanchez, L., Fournier, B., Jolin, M., Bastien, J., & Mitchell, D. (2017). Tools for assessing damage in concrete affected by AAR coming from fine and coarse aggregates. *IBRACON Structures and Material Journal*, 84-91.
- Santana Rangel, C., Amario, M., Pepe, M., Yao, Y., Mobasher, B., Toledo Filho, R.D. Tension stiffening approach for interface characterization in recycled aggregate concrete. *Cement and Concrete Composites, Vol. 82*, 176-189.

- Santos, V.A.A., Valenzuela, F., Gallo, J.B., Pandolfelli, V.C. (2009) What Affects Erosion Resistance of Refractory Castables? *Refractories Applications and News*, v.14, n.6, p.9-16.
- Shakhmenko, G., & Birsh, J. (1998). Concrete mix design and optimization. *Second International PhD Symposium in Civil Engineering, Budapest*, 1-8.
- Smaoui, N., Fournier, M., Bissonnette, B., & Durand, B. (2004). Evaluation of the expansion attained to date by concrete affected by ASR - Part I: Experimental study. *Canadian Journal of Civil Engineering*, Vol. 31, 826-845.
- Stoval, T., De Larrard, F., & Buil, M. (1986). Linear packing density model of grain mixtures. *Powder Technology*, Vol.48, 1-12.
- Stroeven, M., Stroeven, P. (1999). Assessment of packing characteristics by computer simulation. *Cement and Concrete Research*, Vol. 29, 1201–1206.
- Struble, L. J., & Ji, X. (2001). Rheology. Em R. a. Beaudoin, *Handbook of Analytical Techniques in Concrete Science and Technology* (pp. 333-367). LLC Norwich, New York, U.S.A: William Andrew Publishing/Noyes Publications.
- Tomlinson, D., Moradi, F., Hajiloo, H., Ghods, P., Alizadeh, A., & Green, M. (2017). Early age electrical resistivity behaviour of various concrete mixtures subject to low temperature cycling. *Cement and Concrete Composites*, Vol. 83, 323-334.
- Toufar, W., Klose, E., Born, M. (1977), Berechnung der packungsdichte von korngemischen. *Aufbereitungs-Technik*, Vol. 18, 603-608.
- Vogt, C. (2010). Ultrafine particles in concrete - Influence of ultrafine particles on concrete properties and. Stockholm, Sweden: Royal Institute of Technology, School of Architecture and the Built Environment.
- Walsh, J. B. (1965). The effects of cracks on the uniaxial elastic compression of rocks. *Journal of Geophysical Research*, Vol 70, Issue 2 , 399-411.
- Westman, A., & Hugill, H. (1930). The Packing of Particles. *Journal of American Ceramic Society*, Vol. 13, 767–779.
- Zuo, W., Liu, J., Tian, Q., Xu, W., She, W., Feng, P., Miao, C. (2018). Optimum design of low-binder Self-Compacting Concrete based on particle packing theories. *Construction and Building Materials*, Vol. 163, 938-948.