

Real-time, Location-based Hand Hygiene Monitoring and Notification System

Malak Baslyman

Thesis submitted to the
Faculty of Graduate and Postdoctoral Studies
in partial fulfillment of the requirements for the degree of

Master of Computer Science

Under the auspices of the Ottawa-Carleton Institute for Computer Science



uOttawa

University of Ottawa
Ottawa, Ontario, Canada

November 2014

© Malak Baslyman, Ottawa, Canada, 2014

Abstract

Rising infection rates in healthcare is a global issue that causes complications for the patient, extended hospital stay, financial difficulties, and even death. One of the crucial factors that reduce those infections is better *hand hygiene*. Due to the lack of automated systems that can help monitoring hand hygiene compliance and reporting on collected data, some hospitals use direct observations, surveys, dispensers usage measurements and other such methods to monitor the compliance of care providers.

This thesis proposes an alternative system that takes advantage of emerging off-the-shelf infrastructures in hospitals, and in particular of Real-Time Location Systems (RTLS) and intelligent hand sanitizer dispensers. Our RTLS-based system improves upon the current methods by enabling interactions with care providers through notifications when they do not execute expected hand hygiene actions during care processes, even for fine-grained location situations and by introducing the concept of intelligent dispensers. RHMNS (RTLS-based Hand Hygiene Monitoring and Notification System) has two approaches (time-based and activation-based) that are sharing the same structure but they are different in their way of deciding on taken or missed hand hygiene opportunities. RHMNS also provides informative reports about hand hygiene compliance and trends.

Acknowledgment

First of all, whatever blessings or achievements I or any of his creatures rose up with is only from Allah. All grace and thanks are due to him. Then, peace be upon the one who taught people that education is the most precious thing in life and that seeking knowledge is a dignified attitude, prophet Mohammed (pbuh).

I would like to express my deep feelings of appreciation and gratefulness to my decent supervisor, Professor *Daniel Amyot*. Working with him and under his supervision is way beyond a rich experience. He patiently taught me how to see a research opportunity in each problem, how to enjoy facing challenges, how to respect research ethics and how to be a good researcher. He never limited my creativity but he always ensured that I was on the right track. I would like to thank him also as my program coordinator who has been such a big help and who never hesitated to solve my problems or listen to my complaints. Finally, I would like to thank him for training me in staying healthy by using the stairs, going up and down for six floors, instead of taking the elevator.

I would like also to thank the *Saudi Government* for sponsoring me during my studies, the *University of Ottawa* for giving me this generous opportunity to pursue my dreams and *The Ottawa Hospital* for giving me the precious chance of working on solving a real-world problem.

This work would have not been done successfully without the unlimited support of *Alain Mouttham*. I am so grateful for each moment he spent teaching me how to manage a real business. I would also like to thank *Rana Chreyh* for her help and kindness during this work.

I would never forget to thank *Alan Stewart* and *Samer Sader* for helping me implement the intelligent dispenser concept. I am totally thankful to *Renaud Bougueng Tchemeube* for all the time he gave to help me understand the RTLS technology at the beginning of this project.

Raoufeh Rezaee, my officemate, my close friend and my dear sister, I am very thankful for each moment we spent together, for each cup of coffee we had before and during work, and for each moment we faced a challenge, we tackled a problem and we celebrated achievement. Thank you, and even “thank you” is less than what you deserve.

A deeply hearty thank to my beloved family, to whom I owe this achievement and without whose support this work would not have been accomplished. *Haifaa* and *Salim*, my parents, I am so proud of you and of each moment you spent teaching me that education comes first and for all that you have sacrificed to make me the person I am today. *Safieh*, *Shoa’a* and *Abdulnasir*, my grandmother, my aunt and my uncle, without your support and having you around, I would not have been able to have reached this far. My sisters, *Walaa*, *Basher* and *Dalia*, I am so thankful to you for encouraging and motivating me all the way to keep moving forward and improving. A special thank goes to *Walaa* for being always motivated and patient with me and for being my closest friend and my studying partner since I was KG1 till now. *I could not finish this part without thanking my closest friend, Weam, for having my back since forever.*

Finally, I would like to thank my English teacher and dear friend *Phil Soffe*. Without the effort he put in me to improve my English before starting my master’s studies, I would never have been able to write a sentence in this document. I will always be grateful towards him.

Table of Contents

Abstract	i
Acknowledgment	ii
Table of Contents	iv
List of Figures	vii
List of Tables	viii
List of Acronyms	ix
Chapter 1. Introduction	1
1.1 <i>Motivation</i>	1
1.2 <i>Problem Context</i>	2
1.3 <i>Research Question and Thesis Goals</i>	3
1.4 <i>Research Methodology</i>	3
1.5 <i>Thesis Contributions</i>	6
1.6 <i>Publications</i>	7
1.7 <i>Thesis Outline</i>	7
Chapter 2. Background	9
2.1 <i>Hand Hygiene Compliance in Healthcare</i>	9
2.1.1 <i>Hand Hygiene Moments</i>	9
2.1.2 <i>The Role of Hand Hygiene in Reducing Healthcare-Associated Infection Rates</i>	10
2.1.3 <i>Improvement of Hand Hygiene Compliance</i>	11
2.2 <i>Real-Time Location Systems</i>	12
2.3 <i>Chapter Summary</i>	15
Chapter 3. Literature Review	16
3.1 <i>Literature Review Methodology</i>	16
3.1.1 <i>Compose Keywords</i>	16
3.1.2 <i>Gather Relevant Work</i>	17
3.1.3 <i>Filter Gathered Work</i>	18
3.1.4 <i>Extract Data</i>	18
3.1.5 <i>Summarize Data</i>	18

3.2	<i>Traditional Hand Hygiene Monitoring Methods</i>	18
3.3	<i>Automated Hand Hygiene Monitoring Systems</i>	20
3.4	<i>Commercial Systems</i>	23
3.5	<i>Chapter Summary</i>	24
Chapter 4.	RHMNS Architecture	27
4.1	<i>Problem Specification</i>	27
4.1.1	Issues	27
4.1.2	Objectives	27
4.1.3	System Requirements	28
4.1.4	Expected Scenarios.....	30
4.2	<i>System Components</i>	31
4.2.1	Real-Time Location System.....	32
4.2.2	Intelligent Dispenser System.....	34
4.2.3	Real-Time Information Correlation System.....	38
4.2.4	Database Management System.....	41
4.2.5	Information Reporting System.....	43
4.2.6	RHMNS Detailed Architecture	46
4.3	<i>RHMNS Approaches</i>	47
4.3.1	Time-based Approach.....	47
4.3.2	Activation-based Approach.....	47
4.4	<i>Chapter Summary</i>	48
Chapter 5.	Testing and Validation	49
5.1	<i>Proof-of-Concept Demonstrations</i>	49
5.2	<i>Evaluation Strategy</i>	50
5.2.1	Criteria	51
5.2.2	Scoring System.....	52
5.2.3	Scenarios.....	54
5.2.4	Test Setup	56
5.3	<i>Preparation</i>	57
5.3.1	Lab Setup.....	57
5.3.2	Software Configuration (Map, Events, Database).....	58
5.3.3	Test Preparation	59
5.4	<i>Test Implementation and Execution</i>	59
5.5	<i>Results</i>	60
5.6	<i>Challenges</i>	62
5.7	<i>Discussion</i>	63
5.8	<i>Chapter Summary</i>	64

Chapter 6. Discussion	65
6.1 <i>Comparison</i>	65
6.1.1 Architecture.....	65
6.1.2 Features.....	66
6.2 <i>Recommendations</i>	68
6.2.1 Proposed Requirements Types	68
6.2.2 RHMNS Adoption.....	69
6.3 <i>Threats to Validity</i>	70
6.3.1 Construct Validity	70
6.3.2 Internal Validity	70
6.3.3 External Validity	71
6.4 <i>Chapter Summary</i>	71
Chapter 7. Conclusions and Future Work.....	72
7.1 <i>Answer to Research Question</i>	72
7.2 <i>Contributions</i>	73
7.3 <i>Future Work</i>	73
References.....	75
Appendix A: Literature Review Queries.....	80
Appendix B: Sample Hand Hygiene Compliance Reports.....	81
Appendix C: Experiment Sheet	84

List of Figures

Figure 1	Design Science in IS guidelines (Hevner et al., 2004).....	4
Figure 2	Design Science framework (Hevner et al., 2004).....	4
Figure 3	Thesis methodology	5
Figure 4	Ekahau RTLS WiFi tags for patients, assets, and staff	13
Figure 5	Ekahau IR beacon	14
Figure 6	RTLS architecture (Ekahau RTLS Requirements and Design Guide, 2010).....	14
Figure 7	RHMNS goal model.....	28
Figure 8	RHMNS scenario model.....	30
Figure 9	RHMNS abstract architecture.....	31
Figure 10	RTLS subsystems.....	33
Figure 11	The intelligent dispenser: first prototype.....	35
Figure 12	The intelligent dispenser’s system architecture	36
Figure 13	The intelligent dispenser: final prototype.....	37
Figure 14	Momentary switch (in the red cycle) placed inside the intelligent dispenser	37
Figure 15	Database schema of received data in real time (PK = Primary Key, FK = Foreign Key).....	41
Figure 16	EazyBI architecture (EazyBI’s website, 2014).....	44
Figure 17	A sample of overall weekly HH performance in June 2014.....	45
Figure 18	RHMNS detailed architecture.....	46
Figure 19	Room B403 at TOH equipped with RHMNS equipment for the second demo	50
Figure 20	The simulated patient room (university laboratory)	57
Figure 21	Map of the simulated patient room in Ekahau’s Site Survey tool	58
Figure 22	Boxplot diagram of the maximum, minimum and median performance results of RHMNS during the experiment, with boxes representing the 95% confidence intervals (Response time in seconds, the others in %).	62
Figure 23	Sample hand hygiene report generated with EazyBI	81
Figure 24	Sample reports on nurses, with ratios.....	82
Figure 25	Sample report comparing two nurses with bar charts	83

List of Tables

Table 1	Summary of the main approaches competing with RHMNS	25
Table 2	RHMNS requirements.....	29
Table 3	Event table details	42
Table 4	Confusion matrix.....	52
Table 5	Scoring system values	53
Table 6	Precision of decision scores.....	53
Table 7	Robustness scores	53
Table 8	Accuracy of positions scores	53
Table 9	Response time scores	54
Table 10	Mean results of the evaluation process	60
Table 11	Mean results of the evaluation process based on the scoring system	60
Table 12	RHMNS best and worst performance results – scores (and values)	61
Table 13	General comparison between RHMNS and related systems in terms of system architecture.....	66
Table 14	Comparison between RHMNS and competing systems in terms of features	67

List of Acronyms

Acronym	Definition
ABHR	Alcohol-based hand rub
API	Application Programming Interface
FK	Foreign Key
GRL	Goal-oriented Requirement Language
HAI	Healthcare-associated infection
HCP	Healthcare provider
HH	Hand hygiene
HTTP	Hypertext Transfer Protocol
IS	Information System
JDBC	Java Database Connectivity
LED	Light Emitting Diode
PK	Primary Key
QR	Quick Rhythm
RFID	Radio Frequency IDentification
RGB	Red-Green-Blue
RHMNS	Real-Time, Location-based Hand Hygiene Monitoring and Notification System
RTLS	Real-Time Location System
SDK	Software Development Kit
SQL	Structured Query Language
SR	Slow Rhythm
TCP	Transmission Control Protocol
TOH	The Ottawa Hospital
UCM	Use Case Map
UML	Unified Modeling Language
URN	User Requirements Notation
WiFi	Wireless local area network

Chapter 1. Introduction

In this thesis, we propose a novel approach that combines *Real-Time Location Systems* (RTLS) and an innovative *intelligent dispenser* system in a unique way to monitor *hand hygiene* (HH) compliance among healthcare providers (HCP) and remind them in a timely way of missed *hand hygiene opportunities* in case they did not perform any when required. This chapter presents the motivations and the research question. It discusses the research methodology and the contributions. It also highlights the publications produced out of this work and outlines the rest of the thesis.

1.1 Motivation

This work was motivated by the current status of HH compliance in the healthcare domain. Even though much work and many studies showed that optimal HH practice is essential to save patients from going through unnecessary suffering and to reduce the number of death cases because of infections, many healthcare providers do not perform HH as required because of time pressure, the perception that their hands are not dirty, and other reasons that will be explained in details in Chapter 2. One of the issues is the lack of efficient computer-based auditing systems and the lack of interactive systems that remind HCPs of the need of washing their hands or give them feedback on their current performance. Our work aims to improve HH compliance among HCPs and help them to perform optimal HH practice. This will help healthcare organizations limit the propagation of infections, improve patient safety, meet their compliance objectives, and ultimately save human lives.

Another strong motivation point is the interest and collaboration of a real healthcare environment. This thesis results from a project led by the *University of Ottawa* and *The Ottawa Hospital* (TOH). Such partnership provides the opportunity to look at the problem closely and to test proposed solutions in a real environment. It also enables us to get our hands on major concerns of healthcare authorities, real constraints such as patient

and staff privacy, and ideas about possibly acceptable computer-based systems in a healthcare environment.

Yet another motivation is the availability of new and relevant technology. For the past few years, RTLS have been introduced in the healthcare sector to tackle some issues such as tracking patients, staff, devices and other resources. In terms of improving HH compliance, there is some work that proposed automated systems claiming the ability to improve HH by monitoring HCPs or reminding them of missed HH opportunities. However, they currently have severe limitations, as will be discussed in Chapter 3. This encourages us to investigate the ability of RTLS to solve the HH compliance problem and to come up with reliable, robust, and affordable methods to employ and reuse this technology in a new context.

1.2 Problem Context

A healthcare-associated infection (HAI) is “an infection that a patient contracts (or acquires) in a setting where healthcare is delivered (e.g., a hospital) or in an institution (e.g., a long-term care facility) or in a home care arrangement. The infection was neither present nor developing at the time the individual was admitted” (Public Health Agency of Canada, 2013). Raising HAI rates represent a severe issue. Every year in Canada, HAI affect more than 200,000 patients, with more than 8,000 dying as a result (Public Health Agency of Canada, 2013). Deaths caused by *C.difficile* infections have tripled since 1997, while the infection rate associated with *methicillin-resistant staphylococcus aureus* has increased by more than 1,000% between 1995 and 2009. Such trends are observed worldwide by the World Health Organization. The recent *Ebola* virus pandemic in West Africa represents yet another example of a deadly infection that can devastate entire populations if not contained properly.

In addition, such infections are very costly. For example, the overall annual direct medical costs of HAI to U.S. hospitals were estimated to be between \$35 billion and \$45 billion in 2007 (Scott, 2009). Despite the fact the one of the best solutions to this problem is better HH practice, compliance among healthcare providers with optimal HH practice is considered to be less than 40% (Suresh and Cahill, 2007).

1.3 Research Question and Thesis Goals

“Is it feasible to have an RTLS-based system that is reliable, accurate, valid and adoptable, that does not threaten HCP privacy in the context of monitoring HH practice in hospitals, and that reminds HCPs of taking HH actions when required?”

The research question focuses on the possibility of having an automated RTLS-based HH monitoring and notification system that is reliable in terms of performance, accurate in terms of results and decisions, valid in terms of solving real hand hygiene problems and adoptable by real healthcare organizations.

Accordingly, the main goal of this thesis is to answer the research question by:

- 1- Investigating the technical and medical fields and designing an RTLS-based system that has the features required above.
- 2- Validate the designed system.
- 3- Demonstrate the results of using the system in likely scenarios.

1.4 Research Methodology

In order to have efficiently-conducted research, an adequate research methodology that suits the problem context and the means of solving the problem should be followed. Due to the nature of this thesis, which involves business and organizational infrastructures and novel computer-based technology, the *Design Science Methodology in Information Systems (IS)* has been chosen to inspire this thesis' methodology.

The design science methodology in IS combines two complementary methodologies: *behavioural design* and *design science*. Whereas behavioural design focuses mainly on developing and verifying theories and methodologies, design science focuses on the originality and innovation of artifacts to extend knowledge (Hevner et al., 2004). This combination suits the IT field where an artifact should be produced with considerations to existing knowledge in the discipline and should be produced creatively to solve real-world problems. Each artifact produced and validated through the design science methodology should meet seven guidelines summarized in Figure 1. The framework of this methodology is highlighted in Figure 2.

Guideline	Description
Guideline 1: Design as an Artifact	Design-science research must produce a viable artifact in the form of a construct, a model, a method, or an instantiation.
Guideline 2: Problem Relevance	The objective of design-science research is to develop technology-based solutions to important and relevant business problems.
Guideline 3: Design Evaluation	The utility, quality, and efficacy of a design artifact must be rigorously demonstrated via well-executed evaluation methods.
Guideline 4: Research Contributions	Effective design-science research must provide clear and verifiable contributions in the areas of the design artifact, design foundations, and/or design methodologies.
Guideline 5: Research Rigor	Design-science research relies upon the application of rigorous methods in both the construction and evaluation of the design artifact.
Guideline 6: Design as a Search Process	The search for an effective artifact requires utilizing available means to reach desired ends while satisfying laws in the problem environment.
Guideline 7: Communication of Research	Design-science research must be presented effectively both to technology-oriented as well as management-oriented audiences.

Figure 1 Design Science in IS guidelines (Hevner et al., 2004)

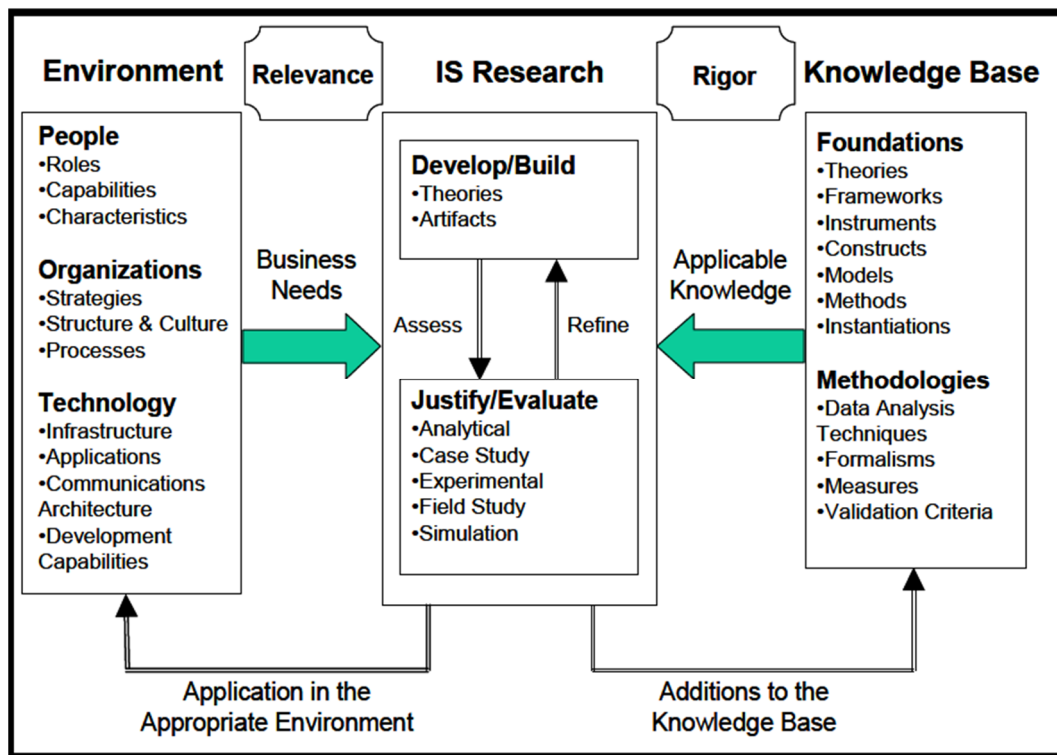

Figure 2 Design Science framework (Hevner et al., 2004)

As seen in Figure 2, there are two elements that feed the IS research component. The first one is the environment in which we find people, organizations, existing technology, problems to solve or performance to improve. The second component is a knowledge base composed of foundations and methodologies related to a potential system to improve or design. The IS research component represents the internal cycle of designing a system that has two overlapping phases: development and evaluation. It is essential in the design science in IT methodology to develop a system that is totally relevant to the environment intending to adopt it and that is rigorously connected to the knowledge base in the same domain.

The thesis methodology has adapted design science methodology as follows:

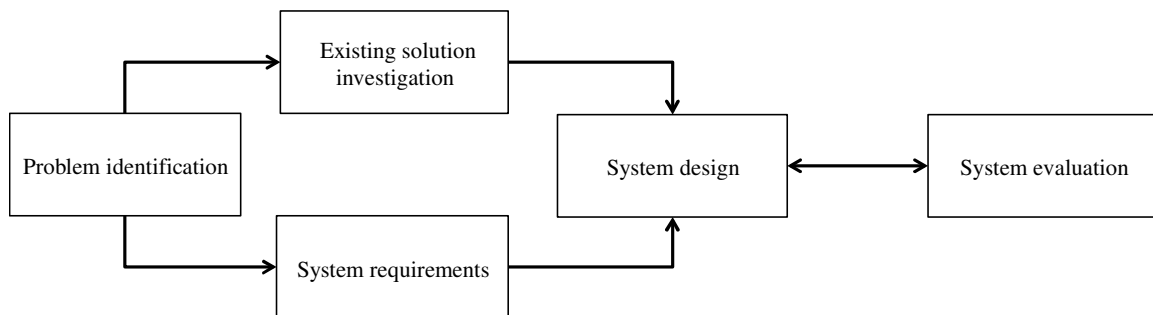

Figure 3 Thesis methodology

As Figure 3 presents, there are five phases in our methodology:

- **Problem identification:** this is the first phase where the problem of lack of appropriate HH practice in healthcare should be studied and identified clearly.
- **Existing solutions investigation:** in this phase, the existing systems (under development or adopted in hospitals) to improve HH compliance among HCPs should be studied carefully to define specifically where are the gaps to fill and how to improve upon them.
- **System requirement:** through many sessions with the stakeholders at TOH, the system requirements should be gathered and the system objectives should be defined.
- **System design:** in this phase, all gathered information should be used to model and develop a unique piece of software that fulfills the requirements and meets the

objectives. Additionally, it should improve on the available system to better monitoring of HH performance.

- **System evaluation:** this phase overlaps with the system design phase. Many demonstrations should be delivered while designing the system and validation experiments should be conducted after building each system iteration.

The way in which the design science methodology in IS is adapted here can be seen clearly in the phases of our methodology. Our phases for problem identification and system requirement belong to the first component of design science, i.e., the environment. The phase focusing on the existing solution investigation is related to the knowledge base component, while the last two phases (system design and evaluation) are equivalent to the IS research component. The guidelines from the design science methodology are also included in our methodology. Our new system is an artifact designed to solve a problem in the real world based on a clear knowledge base in terms of design and evaluation. The search for technology meant to be used in a way that matches hospital regulations is carefully designed. Our system is introduced to both technologist and management-oriented audiences. It has a several contributions that will be explained in the next section.

1.5 Thesis Contributions

There are significant contributions in this work. This thesis provides a novel *RTLS-based Hand Hygiene Monitoring and Notification System (RHMNS)* that:

- Introduces the concept of *intelligent dispenser* system, which transmits activation messages wirelessly to a server when soap or alcohol-based hand rub is being dispensed. Current dispensers only transmit infrared (IR) signals to specific designed devices upon usage. This new concept has a considerable impact on the accuracy of identifying HH actions being taken.
- Integrates the intelligent dispenser with an RTLS-based system.
- Provides an algorithm that identifies the cases where performing HH is required according to Ontario legislation. Most automated systems, as will be shown in Chapter 3, do not cover all these cases (either inside a patient room or when enter-

ing or exiting a patient room). This feature is essential for TOH to diagnose precisely non-compliance reasons among the staff members.

- Identifies each HCP individually and reminds them (via electronic badges) of washing their hands when an HH opportunity is identified as missed.

1.6 Publications

This thesis led to two conference publications. The first is directly related to this thesis while the second is the topic of another thesis, but with shared application infrastructure (RTLS and database).

- **Baslyman, M.**, Rezaee, R., Amyot, D., Mouttham, A., Chreyh, R., Geiger, G. Towards an RTLS-based Hand Hygiene Notification System. *4th Int. Conference on Current and Future Trends of Information and Communication Technologies in Healthcare (ICTH-2014)*, Halifax, Canada, September 2014. *Procedia Computer Science*, Elsevier, Vol. 37, 2014, pp. 261-265.
- Rezaee, R., **Baslyman, M.**, Amyot, D., Mouttham, A., Chreyh, R., Geiger, G. Location-Based Patient-Device Association and Disassociation. *4th Int. Conference on Current and Future Trends of Information and Communication Technologies in Healthcare (ICTH-2014)*, Halifax, Canada, September 2014. *Procedia Computer Science*, Elsevier, Vol. 37, 2014, pp. 282-286.

1.7 Thesis Outline

The rest of this thesis is organized as follows:

- **Chapter 2:** presents background about what HH is, why it is important, HH improvement strategies and concepts related to RTLS technologies.
- **Chapter 3:** discusses the main existing methods designed to monitor and improve HH compliance. These methods vary from very simple ones to highly sophisticated ones.
- **Chapter 4:** presents the RHMNS requirements as well as its goal and scenario models. Then, it discusses the architecture of RHMNS, design choices, and the implementation.

- **Chapter 5:** explains in details an experiment conducted to validate RHMNS at the hospital and in a university laboratory. It presents validation results, and it highlights challenges and threats.
- **Chapter 6:** presents a comparison between RHMNS and other competing systems, discusses recommendations for deployment, and discusses threats to validity.
- **Chapter 7:** concludes the main points of the thesis by answering the research question, recalling the contributions, and summarizing future work items.

Chapter 2. Background

This chapter presents background information on the *hand hygiene* (HH) process, the importance of performing HH in healthcare, and common strategies to improve HH compliance among *healthcare providers* (HCPs). In addition, this chapter briefly explains *Real-Time Location Systems* (RTLS) as they are to be used in our approach to solving the problem. These background concepts and terms are required to better understand and appreciate the literature review presented in the next chapter.

2.1 Hand Hygiene Compliance in Healthcare

Hand hygiene is the act of cleaning hands by the use of running water, soap or *alcohol-based hand rub* (ABHR) to remove visible soil or invisible microorganisms (Public Health Ontario, 2014). Unclean hands of HCPs are one of the transport means of *Healthcare-Associated Infections* (HAIs, e.g., catheter-related bloodstream infection and catheter-related urinary tract infection) from a patient to another. Although cleaning hands seems to be an obvious act while being a powerful weapon against HAIs that cause death and unnecessary suffering to patients and their families, the compliance to HH regulations among HCPs in Canada is less than 40%, as reported by Public Health Ontario (2014). In the following sections, we discuss where performing HH is required as well as methods to improve adherence to HH best practices.

2.1.1 Hand Hygiene Moments

The term *moment* has been used widely to refer to the situations where HCPs shall perform HH. According to Public Health Ontario (2014), there are four moments where HH is strictly required: before initial patient/patient environment contacts, before aseptic procedures, after body fluid exposure risks and after patient/patient environment contacts. Furthermore, the first and last moments include cleaning hands once an HCP enters a patient room and before leaving the room, even if the HCP did not touch a patient or their

environment inside the room. Sax et al. (2007) proposed the so-called ‘My five moments for hand hygiene’ methodology, which includes the above four moments but with the fourth moment split into two separated parts: after initial patient contact and after initial patient’s surrounding (devices, sinks, etc.) contact. This methodology provides a better understanding of when and where HH is definitely needed. In addition, it helps HCPs to perform HH when they are having complex or multiple tasks to accomplish at the same time as it flows naturally into their workflow. This methodology was also created for the purpose of simplifying and clarifying the HH concept during training, observation and reporting on performance sessions.

2.1.2 The Role of Hand Hygiene in Reducing Healthcare-Associated Infection Rates

These days, hand hygiene remains an important issue due in part to disappointing compliance rates. Public Health Ontario (2014) observes that 90% of patients in Canada feel more comfortable with healthcare services knowing that there is an HH program in place. Many studies mention that HH is an element crucial to ensuring patient safety and reducing HAI rates. Cleaning hands with ABHR, which is considered a partial replacement for hand cleaning at sinks, will kill most invisible transient microorganisms. Cleaning hands hence helps improve patient safety while decreasing HAI rates.

Very recent work done by Salama et al. (2013) is a good example of the facts discussed in the previous paragraph. Salama et al. led a 7-month experiment to investigate the relation between performing HH consistently and HAIs, and the impact of education (including lectures, posters, feedback on compliance and further explanations on why, how and when to perform HH) in the fourth month of the experiment on increasing HH compliance. Their findings show that the rate of HH compliance increased from 42.9% to 61.4% with education. More interestingly, the rate of HAIs per 1000 patient-days decreased sharply from 37.2 to 15.1. Other studies have shown similar results, including those of Pessoa-Silva et al. (2007) and Grayson et al. (2008).

On the other hand, there are also a few studies showing that increasing HH compliance has not caused significant reduction in HAI rates (e.g., Thi Anh Thu et al., 2007) and that intervention has had no impact on improving HH compliance (e.g., Rupp et al.,

2008). However, there are two factors that negatively affected the results of these studies: the duration of experiments and the design of the interventions themselves.

2.1.3 Improvement of Hand Hygiene Compliance

In order to improve compliance to the HH process, the reasons for disobedience should first be considered. Grol and Grimshaw (2003) as well as Pyne (2010) provided some reasons for not adhering to HH activities. One of the reasons is that HCPs are not convinced of the significance of performing HH robustly and frequently due to the absence of concrete evidence of its effectiveness, and to lack of knowledge or institutional policies. Some HCPs reported that they thought they were performing HH as it should be done (they were surprised to learn that they were not) whereas others attributed non-compliance to the heaviness of workload, the lack of facilities, bad location of dispensers, oblivion, or fear of harming their hands by frequently using chemical cleaning substances. Another interesting point to mention is that some HCPs (especially nurses) care mainly about immediate consequences and their own safety; this explains why they care the most about wearing gloves (Squires et al., 2013).

With the knowledge of many reasons for non-compliance, several studies attempted to design strategies and approaches in order to promote HH in hospitals. Precise analysis of reasons and various carefully-planned strategies are key to improving HH performance among HCPs. One of the approaches is a campaign that includes educational lectures, training sessions, group discussion sessions, role models, etc. However, such attempts will not succeed without support related to social norms (activists, press, authorities, etc.) and, mainly, without governmental support (Grol and Grimshaw, 2003). Let us take the European experience at improving HH in healthcare as a successful example. Belgium, England and France, by uniting the efforts of healthcare institutions (organizing country-wide campaigns) and the efforts of their governments, succeeded in increasing awareness all around their countries, which resulted in increasing HH compliance (Magiorakos et al., 2010).

There are also some innovative approaches such as SureWash¹. This is a commercial computer-based system designed for the sake of training HCPs on the desired performance of HH. SureWash is provided with monitors to show HCPs how to clean their hands effectively, and with video cameras to record the way HCPs clean their hands compared to the presented information. The system gives HCPs immediate corrections and recommendations to improve hand cleaning (Higgiens and Hannan, 2003).

Many studies highlighted the importance of *reminders* in encouraging HCPs to perform HH. More precisely, some healthcare providers mentioned that their performance would be much better if they were reminded of cleaning their hands. Reminder methods are different in complexity and influence; they could range from very simple posters and signs to advanced electronic alerts or flashing lights. In addition, monitoring and giving feedback on each HCP's individual performance would help promoting self-conscience to respect hospital policies. The development and the impact of such methods are main concerns of our work, and they will be discussed in more detail with examples in Chapter 3.

2.2 Real-Time Location Systems

“Real-time location systems (RTLS, also known as real-time locating systems) are local systems for identification and tracking of the location of assets and/or persons in real or near-real time” (Boulos and Berry, 2012). Generally, RTLS systems are RFID (Radio Frequency IDentification) over WiFi (wireless local area networks), but different vendors use different technologies. Examples of such technologies include systems that enable different components of an RTLS to communicate wirelessly over an existing WiFi infrastructure, infrared (IR) signals that can cover room-level areas precisely, etc. (Healthcare IT News, 2009²). Aeroscout (2011) and Ekahau (2014) are amongst the most popular RTLS vendors.

In an RTLS, each device (tags for patients, badges for HCPs, asset tags for mobile devices, etc., see Figure 4) is equipped with location sensors that can report the current location. In the Ekahau world, these small devices communicate with software located in

¹ <http://www.surewash.com/>

² <http://www.sonitor.com/pdfs/0912.pdf>

an RTLS server called “positioning engine” to send required information such location ID (identifier), events occur based on some defined rules, time, change in temperature, etc. It is possible to get the position of a specific device by relying only on the WiFi network based on triangulation or on the monitoring of signal strengths (with a low and fluctuating precision of about 3-4 meters), or by using IR beacons (with a maximum resolution of one meter, sufficient to distinguish beds in hospital rooms). The beacons (Figure 5) are usually passive, which means they only send information when location sensors integrated into devices trigger them, and they are capable of covering areas that starts from a meter up to 100 meters (e.g., a full room or a corridor). All tags can be configurable to be passive or active; active tags do not need any trigger to activate their location sensors and they can report on their location periodically, e.g., every 5 seconds or even every day, depending on what is required. Moreover, client interfaces such as end-user applications or browser-based applications, e.g., *Ekahau Vision*, can be provided with an RTLS to help users monitor and track (and even define rules for tracking) equipment, staff or whoever is tagged. Application Programming Interfaces (APIs) are usually supplied to provide open communication from the user’s side to the positioning engine side, so that users have more freedom to customize the product to fulfill their own needs. Another core component is *Site Survey*, a WiFi-planning and survey application that enables the user to plan floors and to upload maps into the positioning engine. All location data gathered by this tool is sent to the positioning engine in order to track tags and monitor areas. A complete RTLS architecture is presented in Figure 6.



Figure 4 Ekahau RTLS WiFi tags for patients, assets, and staff



Figure 5 Ekahau IR beacon

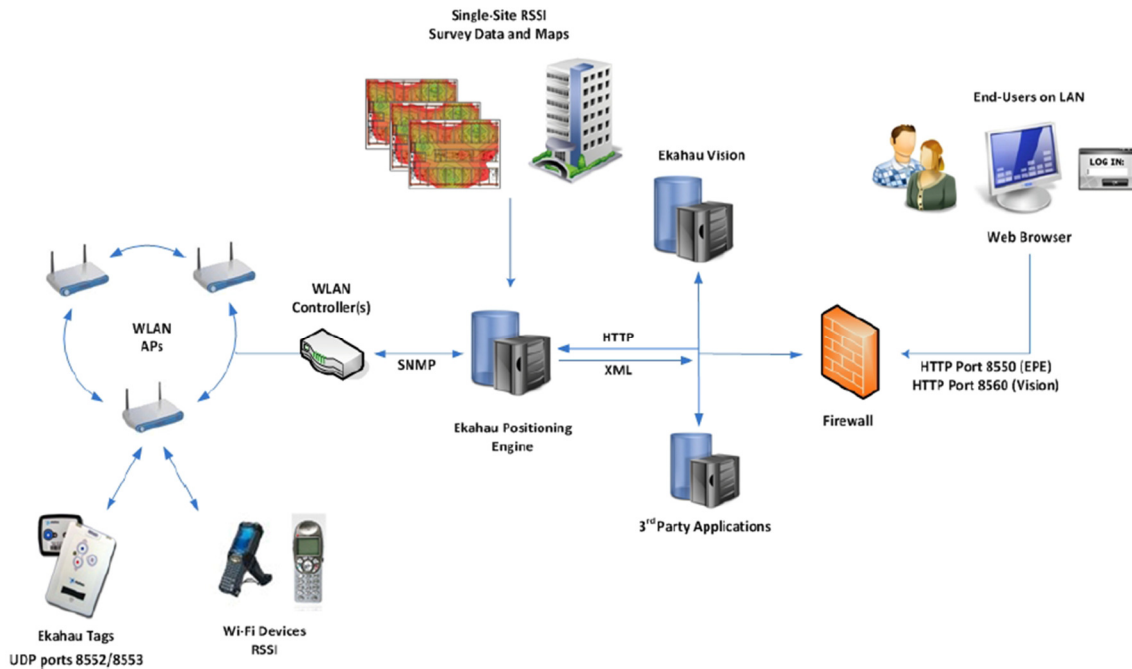

Figure 6 RTLS architecture (Ekahau RTLS Requirements and Design Guide, 2010)

RTLS are often used to solve healthcare-related issues (Boulos and Berry, 2012). An RTLS could be deployed to track patients or ensure their safety in hospitals (especially in the case of Alzheimer and dementia patients), to find equipment quickly when needed (Rezaee et al., 2014), to track patient flows or movement, or to measure wait times in emergency rooms (Tchemeube, 2013; Tchemeube et al., 2013). Another way to amortize the investment in this expensive technology would be to use it also for improving HH compliance. This point is going to be studied in Chapter 3 and then we will explain our deployment of a specific RTLS in such context in Chapter 4.

2.3 Chapter Summary

This chapter presented important background concepts and terminology and discussed the position of HH on the healthcare map. It highlighted the crucial importance of performing HH and its effect on reducing HAIs. Another covered point was the approaches designed to improve HH compliance supported by some successful examples. Lastly, RTLS, the technology used as a solution for many healthcare issues, was discussed as well. In the next chapter, how this technology and others have been employed to solve the HH problem will be presented through a literature review.

Chapter 3. Literature Review

This chapter provides a review of the main approaches to monitoring hand hygiene (in real time), together with an assessment against important evaluation criteria such as what monitored opportunities (e.g., the moments discussed in the previous chapter) are covered, whether hand hygiene actions are recorded, whether HCP can be identified individually, whether reminders can be sent in real time, and whether the proposed approach was validated.

3.1 Literature Review Methodology

In this research, a literature review methodology composed of five steps has been followed to ensure that most of the work relevant to ours has been covered. The steps are: compose keywords, gather relevant papers, filter the gathered papers, extract data from the filtered papers and summarize the result. These steps will be discussed in details in the following subsections. This methodology has been inspired by the approaches of Khan et al. (2003) and Brereton et al. (2007).

As we are interested in ways to assess whether an individual HCP is performing HH at the right moment as well as at ways to remind them to do so if this is not the case, any work that is relevant should cover at least one of the following criteria:

- Automated or electronic monitoring HH compliance system in healthcare.
- Real-time monitoring HH compliance system in healthcare.
- Real-time prompting system in healthcare.
- Experimented and validated system in healthcare.

3.1.1 Compose Keywords

This step is not just about finding the suitable keywords for running queries, but also about choosing search engines and testing the chosen keywords. In terms of choosing the appropriate keywords, it was decided to cover two major parts, which are HH monitoring

systems and HH notification systems, first separately and then together (as a third part). Each part was used to find the probable keywords that might lead to relevant work. For example, in the HH monitoring part, the following are potential keywords: hand washing, compliance, obey, control, healthcare, healthcare workers, health providers, challenge, problem, etc. More advanced queries were constructed out of the more promising keywords from the three parts, such ((“hand hygiene” OR “hand washing”) AND “monitoring” AND (“RTLS” OR “RFID”)). The final queries are included in Appendix A.

The resulting queries have been used on several search engines for two reasons. The first reason is to know to what extent the queries are useful and to choose the best ones, at times with some fine-tuning (to ensure a reasonable and manageable number of papers were returned). The second one is to see which search engine can perform better in our research area, which combined two separate domains: healthcare and real-time location and tracking systems. The best results were obtained by using Google Scholar, SpringerLink, IEEE Explorer and PubMed. Two conditions have been selected in each engine to “sort papers based on most relevant results” and “show articles in journals or papers in conferences”. Some search engines have been discarded, e.g., Scopus and ScienceDirect, because they have almost the same relevant work acquired by the chosen search engines and these search engines have more relevant work than the discarded ones. The final queries (Appendix A) have been used on the four selected search engines.

In addition to using the four search engines to write the literature review, there are some other important data sources used in this chapter. The University Ottawa digital library, the expertise of industrial collaborators, commercial web sites and ad hoc searches enriched the chapter.

3.1.2 Gather Relevant Work

After the advanced queries have been run on the four search engines, a total of 101 papers have been collected. The abstracts of the papers were read to decide whether each paper was within the scope of this research based on the criteria mentioned in section 3.1. As a result, a total of 70 papers have been selected.

3.1.3 Filter Gathered Work

Each paper remaining after the previous step was reviewed again, but this time with a deeper look at the introduction, results and methods, in order to make a decision on the usefulness and relevance of each paper to the research area. This step reduced the number of papers to 26. Many excluded papers were discussing automated monitoring systems and the effectiveness of having reminder systems in theory. Some of these excluded papers were still useful in a generic way and were used in the background chapter.

3.1.4 Extract Data

The final 26 papers were read carefully in order to extract data that supports the papers' assumed concepts, methods and gained results.

3.1.5 Summarize Data

In the last step, we summarized the most relevant and important data and synthesized paragraphs that describe the papers and findings briefly and precisely. A summary table was also produced.

Note that there were several iterations through the five steps to attain the desired result and papers, especially for the first and third steps. The next sections describe our finding based on the type of HH monitoring approach (traditional, automated, commercial), with a summary at the end of the chapter.

3.2 Traditional Hand Hygiene Monitoring Methods

Due the crucial importance of HH, as highlighted in Chapter 2, monitoring HH performance has become more and more necessary in order to improve HH compliance among HCPs. The *gold standard* in this area, i.e., the oldest method and a most trustable one according to healthcare administrators, is *direct observation*. This widely-used method consists in sending auditors to shadow HCPs and record each HH action they perform and HH opportunity they miss (Haas and Larson, 2007). Although this can be a rather precise method to measure HH compliance, direct observation is a very expensive and time-consuming job. In addition, it can threaten patient privacy when auditors shadow

HCPs (Gould et al., 2010), and it is susceptible to the *Hawthorne effect*, whereby HCPs improve their behavior when they know they are being observed by an auditor, sometimes with a 300% difference (Ali et al., 2013). Therefore, alternatives to direct observation have been considered, such as self-reporting and peer reporting.

Another interesting alternative consists in measuring the amount of gel or ABHR consumed daily, which is called *product uptake*. Gould et al. (2010) claimed that the method could be more accurate than direct observation, and that their combination could be even more accurate compared to the each individually. Using a product uptake method is inexpensive, does not involve tedious work, does not disrupt the medical routine or the patient privacy, and avoids the Hawthorne effect bias. However, it cannot identify the behavior of HCPs in performing HH individually, and even less in real time.

Boyce et al. (2008; 2009) proposed a prototype to automate the product uptake method by embedding electronic devices into ABHR dispensers (from Gojo³) to record the frequency of HH performed actions. The prototype records the time and date of each HH action and stores this data in a database located in the embedded device. The stored data is transferred to a computer via a data logger in order to compare it against the numbers of patients and HCPs in certain units. Boyce et al. conducted a six-month trial, which showed the accuracy of such system by recording more than 150,000 HH events in the monitoring period. Moreover, it revealed that most HH events were taken by the dispensers located in the corridors rather than those located in patient rooms.

Another example of automating the uptake method is the work done by Kinsella et al. (2007). They instrumented Gojo ABHR dispensers with sensors to detect the act of using the dispensers. Their study aimed to measure how many times HH actions were performed in a 47-day trial and to figure out the impact of the dispensers' locations on performing HH. Kinsella et al. reported that the dispensers located at the entrance of rooms were used more frequently than the ones located at the opposite side of the entrance or than the gel at patient beds.

Both of these systems are useful attempts in terms of automating uptake methods; however, they lack too many important features that qualify them to be automated moni-

³ http://www.gojo.com/united-states/market/healthcare/smartlink-compliance-solutions.aspx?sc_lang=en

toring HH systems, such as recognizing HCPs individually or notifying them of missed HH opportunities in a timely way.

3.3 Automated Hand Hygiene Monitoring Systems

The need for automated systems to monitor HH is becoming increasingly important because of the limitations and cost of human-based observation methods and because of the need for real-time interactive reporting systems. One of the very early attempts is the study done by Swoboda et al. (2004). The main objectives of their study were to investigate the feasibility of having an automated monitoring and notification system and to see the impact of such system on the decrease of nosocomial infections. The system is composed of three major components: 1) motion detectors located at the entrance of each patient room to detect room entering and exiting events, 2) sensors embedded into (soap and ABHR) dispensers, sinks and water taps to send radio signals if any of them was activated, and 3) a computer to correlate the collected data. In case someone entered or exited a room and did not wash their hands, the system would generate an audible sound to remind them of washing their hands (and between 10 pm and 6 am, the system would remind them via visual messages). By the end of the trial, the study found that nosocomial infections decreased by 48% while the compliance rates increased in the monitoring and prompting phase by around 10% and in the last phase (monitoring only) by around 7% with respect to the baseline. One of the drawbacks of this system is that it cannot distinguish between HCPs and visitors. This system was designed to remind HCPs who have to practice HH and already have HH practice background, but not visitors. In addition, if more than one person entered a room at once, the system would consider them as one entering event.

Venkatesh et al. (2007) developed a similar approach in terms of the means used to monitor HH compliance. The main objective of their study was to investigate the impact of audible prompts on improving HH compliance. The study proved by the end of a six-month trial that the compliance improved by approximately 35%. However, the improvement of compliance did not show a significant difference in reducing HAIs.

Polgreen et al. (2010) proposed a WiFi-based system that can monitor room entering and exiting events and as well as HH performance through the use of small devices

called *motes*. There are three types of motes: badges to be worn by HCPs, beacons to monitor the room and triggers attached to off-the-shelf hand hygiene dispensers. The three kinds of motes can send information, such as timestamp and signal strength, wirelessly to each other. The received information is stored in a flash memory integrated in each mote in order to use the collected data to compute the compliance level over a specific period of time. Polgreen et al. claimed that their proposed solution is effective and inexpensive compared to state-of-art technologies like RFID-based system.

MedSense is a more sophisticated electronic monitoring system proposed by Cheng et al. (2011). A group of devices is used to monitor the compliance of performing HH before and after initialing contact with patients. The devices are badges for HCPs, beacons to cover each patient zone, and sensors embedded into soap and ABHR dispensers to send wireless signals to the badges when they have been activated. The badges read information sent by beacons and dispensers, and they send the information wirelessly to a server that has logic for detecting HH opportunities and actions, and for generating reports on the collected data. In the conducted eight-month trial, Cheng et al. found that the error rate when detecting HH action and opportunities is just 14.4% per hour compared to direct observation.

Snodgrass (2013) came up with a system that is similar to the idea presented in MedSense in terms of having three devices communicating wirelessly, but this system has an innovative feature in terms of the way chosen to notify HCPs of HH status. The badges are provided with three different colors of light (red = need to wash hands, yellow = about to need washing hands, and green = clean hands). Each bed and each dispenser monitored by a beacon is able to cause the light color of a badge to change. For example, if an HCP performs an HH action before touching a patient, the dispenser beacon involved makes the light color change to green. When the HCP enters the patient zone, the zone's beacon makes the light color change to yellow. If the HCP does not perform an HH action after getting out of the patient zone, the light color changes to red. Then, if there is still no HH action taken, an alert may be generated to remind the HCP about washing hands. Sahud et al. (2010) also presented a system similar to MedSense and Snodgrass' work with respect to the concepts and the methodology used for monitor-

ing HH compliance, but this system is also different in that it is RFID based and does not remind HCPs of missed HH opportunities.

Levchenko et al. (2011; 2012; 2013) developed, at the Toronto Rehabilitation Institute, a unique system that consists of three independent types of components: controllers and infrared emitters for monitoring areas, wearable electronic monitoring devices, and wearable dispensers. The system scans patient rooms and corridors looking for HH opportunities and sends reminders to healthcare providers when appropriate. Then, if a hand hygiene action is performed, a signal is sent from a dispenser to the wearable electronic monitors of the person who performed the action. Moreover, this system records every HH opportunity and action, and records where HH actions were performed before or after the reminders. The collected data is downloaded to a personal computer to generate reports and statistics. The research findings showed that when testing the system, the HH activity rates have increased by more than 1.5 times compared to the baseline observational study. Another important point is that the participants in the experiments preferred to receive a vibration signal instead of an audible signal in case they missed HH opportunities.

Armellion et al. (2012) developed an original system made of three major component types: motion-sensors placed at the entrance of each room to identify room entering and exiting events, video cameras located with views of each sink and dispenser to record HH actions, and human auditors to monitor HH compliance when an HCP gets into a room. Based on the evaluation from the human side of the use of dispensers and the data collected from the sensors, the system either sends text to be shown on LED (Light Emitting Diode) screens located in the hallway to remind HCPs of washing their hands, or just summarizes the collected data during the day and sends it by email. The conducted a 107-week experiment (from June 2008 to June 2010), which showed that the real-time feedback feature increased the compliance rate dramatically (from around 10% in the pre-feedback period to 81.6% in the post-feedback period).

Another interesting system is the one proposed by Fisher et al. (2013). The main objective of their system is to study the possibility of replacing manual auditing of HH compliance with an automated audit system. Basically, the system shares the same features as the previous ones, namely monitoring HH actions and notifying healthcare pro-

viders of missed HH opportunities. The only difference here is the system components, which affect the result of the research. These components are: protection zone transmitters to cover patient beds separately, wash transmitters embedded into dispensers that send ultrasound signals when dispensers are used, and wireless tags carried by healthcare providers to receive ultrasound signals sent by dispensers and to report on missed and taken HH actions to the system. Surprisingly, their wireless Hand Hygiene Monitoring System underestimated HH opportunities and HH compliance by 5.2% in comparison to manual audits. They claim that the reasons for this difference could be either that some dispensers did not have transmitters or that the communication between tags and wash transmitters was lost at some point. One more possible reason is that some protection zones transmitters were blocked.

While most systems are designed to monitor HH compliance, a second system is created to analyze non-compliance behavior that could occur because of bad positioning of dispensers, inconvenient room structure or similar causes. Boudjema et al. (2013) decided to think out of the box by creating a system that records the movements and paths taken by health providers to reach patients. Each room is instrumented with four floor-level antennas, located at a room entrance, below two dispensers and in a patient area in the room, to read RFID tags embedded into shoes of health providers. The decision of performing HH action is taken based on steps that health providers take to reach patients and the level of hydro-alcoholic liquid in dispensers. A recording camera was set up to compare obtained results of the system against recorded videos. The evaluation of the system illustrated that the sensitivity and accuracy of the system were very high almost all the time. However, the system reported some false information when healthcare providers performed HH actions very quickly (in less than 5 seconds), or did not touch the floor, or had contacts with patients from the side of beds that did not have antenna, or because of misplacements of beds.

3.4 Commercial Systems

Generally speaking, commercial systems are mainly about using RTLS technology, monitoring HH compliance once an HCP enters or exits a patient room, and reminding and reporting upon collected data. Some companies that are manufacturing RTLS hard-

ware and developing software tried to combine their solutions with another solution provided by another companies. A good example would be Aeroscout (2011), which integrated a sensor into the SmartLinked dispensers manufactured by Gojo and used it side-by-side with Aeroscout's own RTLS technology. The result is a system that can track HCPs individually and can receive IR activation messages from smart dispensers once they have been activated.

On the other hand, companies like SafeHeaven⁴ decided to have the same system architecture as Aeroscout's, but by providing a full solution that uses its own hardware and software. Hence, SafeHeaven designed both RTLS and smart dispenser hardware and software. Other similar systems include: Hill-Rom⁵, AIRISTA⁶ and IntelligentM⁷.

However, there are systems quite different from what is mentioned above in terms of structure or features. For example, the BioVigil⁸ system provides small sensors to be located above patient room doors. Those sensors send reminders (red/yellow LED and audible alert on portable BioVigil tags) to HCPs about washing their hands. The tags use a chemical sensing technology to decide whether HCPs respond to the reminders by washing their hands or not. All data is stored into the tags' memory and is loaded later on into a secure database in the tags station. A study by Edmond et al. (2010) showed significant improvement in HH compliance using BioVigil's approach.

3.5 Chapter Summary

In conclusion, a number of competitive systems have been presented in this chapter. They vary with regards to the complexity of technical means. Some of them are simply sensor-based applications, while the others are WiFi-based or RFID-based systems. More sophisticated and original approaches with respect to the adopted technology or the idea of notifying HCPs or analyzing their behavior have been discussed as well. Almost all automated systems shared common features such as identifying HH opportunities and re-

⁴ <http://info.versustech.com/safehaven-hand-hygiene>

⁵ <http://www.hill-rom.ca/ca/>

⁶ <http://www.airista.com/>

⁷ <http://www.intelligentm.com/>

⁸ <http://www.biovigilsystems.com/>

minding HCPs of missed ones. They proved the feasibility of being considered as replacements for traditional observation methods.

Table 1 Summary of the main approaches competing with RHMNS

Approach	Technology	Monitor HH opportunity	Record taken HH actions	Identify HCP individually	Remind HCP of missed HH	Validation
Boyce et al. (2009)	Embedded sensors into dispensers to count the number of usages	None	Yes	No	No	Yes
Kinsella et al. (2007)	Embedded sensors into dispensers to count the number of usages	None	Yes	No	No	Yes
Swoboda et al. (2004)	Embedded sensors into dispensers and sinks + motion-detectors in doorways	Enter/exit room	Yes	No	Yes	Yes
Venkatesh et al. (2007)	Embedded sensors into dispensers and sinks + motion-detectors in doorways	Enter/exit room	Yes	No	Yes	Yes
Polgreen et al. (2010)	WiFi-based communicating devices: room beacon + integrated beacons into dispensers + HCP badges	Enter/exit room	Yes	Yes	No	Yes
Cheng et al. (2011)	WiFi-based communicating devices: bed beacon + integrated beacons into dispensers + HCP badges	Before/after contact patient	Yes	Yes	No	Yes
Snodgrass (2013)	WiFi-based communicating devices: bed beacon + integrated beacons into dispensers + HCP badges	Before/after contact patient	Yes	Yes	Yes	N/A
Levchenko et al. (2012)	IR emitters to monitor zones+ wearable dispensers + wearable electronic monitoring device	N/A	Yes	Yes	Yes	Yes
Armellion et al. (2012)	Motion-detectors in doorways + video cameras in sinks and dispensers zone + human third-party	Enter/exit room	Yes	No	Yes	Yes
Fisher et al. (2013)	Ultrasound transmitters over bed and embedded into dispensers + wireless HCP badges	Before/after contact patient	Yes	Yes	Yes	Yes
Boudjema et al. (2013)	RFID-based antennas located in doorways + under dispensers + around bed + embedded into HCPs' shoes	Enter/exit room + Before/after contact patient	Yes	Yes	No	Yes
Edmond et al. (2010)	Motion-detectors in doorways + chemical sensing HCP badges	Enter/exit room	Yes	Yes	Yes	Yes

The field of automated HH monitoring systems is still immature but it is improving and growing rapidly. Table 1 highlights the main competing systems, which were presented in scientific publications and are not exclusively commercial, to this thesis' RHMNS. For each system, the table presents its technology, its ability to monitor HH opportunities and to record HH actions, its ability to remind HCPs of missed HH opportunities and availability of validation (these are the criteria presented in section 3.1). Our system attempts to contribute to this area by filling the gaps between the current systems and what is truly needed, and by the uniqueness of its architecture. These points will be discussed in the next chapter.

Chapter 4. RHMNS Architecture

This chapter discusses the architecture of our proposed system, namely RHMNS, and discusses each component in details. In addition, it presents two approaches that have been designed to solve the problem differently but using a shared infrastructure.

4.1 Problem Specification

4.1.1 Issues

As explained in Chapter 2, one of the main issues in the healthcare sector is the low rate of HH compliance among HCPs. Not performing HH as required may cause transmitting certain kinds of infections from patients to patients via HCPs' hands. Yes, improving HH practice (by traditional methods) and fighting infection transmission in hospitals are very costly. Hence, there is a need for having effective automated systems that help healthcare authorities to monitor the current status of HH compliance among their staff, to design long-term improvement plans, and to help HCPs improve their HH performance.

4.1.2 Objectives

Based on the problem context and hospital (i.e., TOH) concerns, there are three main objectives for the solution system in this thesis:

- 1- Monitor HH compliance among HCPs.
- 2- Notify HCPs of missed HH opportunities.
- 3- Generate reports on collected data.

Indirectly, reports and notifications will also help ensuring staff and patient safety through reductions of HAIs. There are also a few secondary objectives for the system, such as: testing the ability of RTLS technology to function appropriately in such context, having more reliable and effective methods for monitoring HH compliance, and deciding

whether the system is sufficient for adoption in a real healthcare environment. Note that our system monitors and notifies HCPs only; patients and visitors are out of the scope of this thesis.

The goal-oriented model⁹ in Figure 7 highlights the system goals and requirements briefly, and additionally TOH's objectives, which are: improve patient safety, evoke long-term improvement and minimize cost (RTLS is already used at TOH). Various positive contributions are identified, as well as dependencies (the **D** links) of the information correlation solution on an RTLS and on an intelligent dispenser.

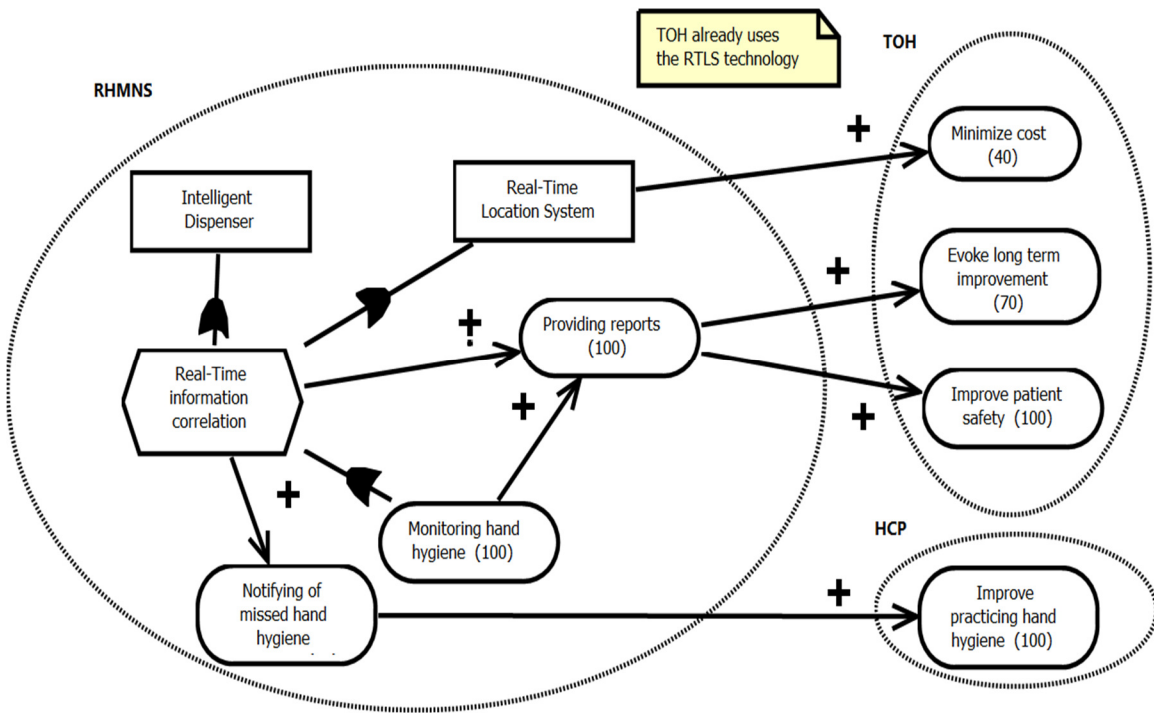

Figure 7 RHMNS goal model

4.1.3 System Requirements

The requirements listed below have been designed to meet the objectives and to clarify precisely the functionalities of the system. Table 2 contains the requirements with their current status, and matches them with the objectives. Note that these requirements were validated by collaborators from the biomedical engineering department at TOH.

⁹ The notation used in this diagram is the Goal-oriented Requirement Language – GRL (Amyot and Mussbacher, 2011). The diagram highlights the system, its actors, their goals, and impacts of solutions.

Table 2 RHMNS requirements

ID	Requirements	Importance	Status	Objective
R1	The system shall identify who comes into a patient room.	Mandatory	Done	Obj. 1
R2	The system shall record ID and time of entering and exiting the room of HCPs.	Mandatory	Done	Obj. 1
R3	The system shall record time that HCPs enter and exit a hand sanitizer zone. (A hand sanitizer zone is an area covered by a beacon located above a dispenser).	Mandatory	Done	Obj. 1
R5	The system shall calculate the time that HCPs spend at a hand sanitizer zone.	Mandatory	Done	Obj. 1
R6	The system shall record a patient zone that HCPs enter and exit. (A patient zone is an area covered by a beacon above a patient bed).	Mandatory	Done	Obj. 1
R7	The system shall detect the use of dispensers.	Mandatory	Done	Obj. 1, Obj. 2
R8	The system should detect the use of an infrared enabled hand sanitizer.	Optional	Proposed	Obj. 1, Obj. 2
R9	The system shall decide whether HCPs washed or did not wash their hands when they come into/out of a patient room based on data collected from R3 to R7.	Mandatory	Done	Obj. 1, Obj. 2
R10	The system shall notify HCPs (via a tag buzzer signal) to wash their hands in case they enter a room and spend more than 60 seconds without washing their hands.	Mandatory	Done	Obj. 2
R11	The system shall remind HCPs (a second time) to wash their hands in case they entered a patient zone before washing their hands, via tag buzzer.	Mandatory	Done	Obj. 2
R12	The system shall notify HCPs of washing their hands in case they move from a patient zone to another patient zone in one room without entering a hand sanitizer zone.	Mandatory	Done	Obj. 2
R13	The system shall notify all HCPs of washing their hands in case the number of dispenser events is less than the number of health providers who were at a hand sanitizer zone at the same time.	Mandatory	Done	Obj. 2
R14	The system shall not notify HCPs of washing their hands in case they exit a patient zone and enter it again without leaving the room or moving to another patient zone inside the room.	Mandatory	Done	Obj. 2
R15	The system shall generate reports that contain HCPs' types, dates and washing hand confirmation.	Mandatory	Done	Obj. 3

4.1.4 Expected Scenarios

In a healthcare environment, HCPs are behaving differently but there is a behaviour pattern that was noticed by the thesis author after shadowing nurses for a whole day at TOH. In addition, the nature of their job restricts them to work within specific scenarios with respect to HH performance. Therefore, there are a few scenarios that HCPs are expected to behave within and that the system should support.

First, the best-case scenario in which HCPs wash their hands in any hand sanitizing area when needed (when entering a patient room, before an initial patient contact, after an initial patient contact, before moving to another patient, and when leaving the room). Second, the worst-case scenario in which HCPs do not wash their hands where needed; as a result they should be reminded of each missed HH opportunity. There are also scenarios mixes of scenario parts in which HCPs wash their hands in some cases and do not wash their hands in others. For example, HCPs wash their hands when entering a room but not before leaving the room. The model in Figure 8, expressed with the use Case Map (UCM) notation (Amyot and Mussbacher, 2011), defines these scenarios, including the notification activity to remind HCPs of washing their hands. Each path with arrows represents a potential scenario and each **X** represents an activity or responsibility to be performed.

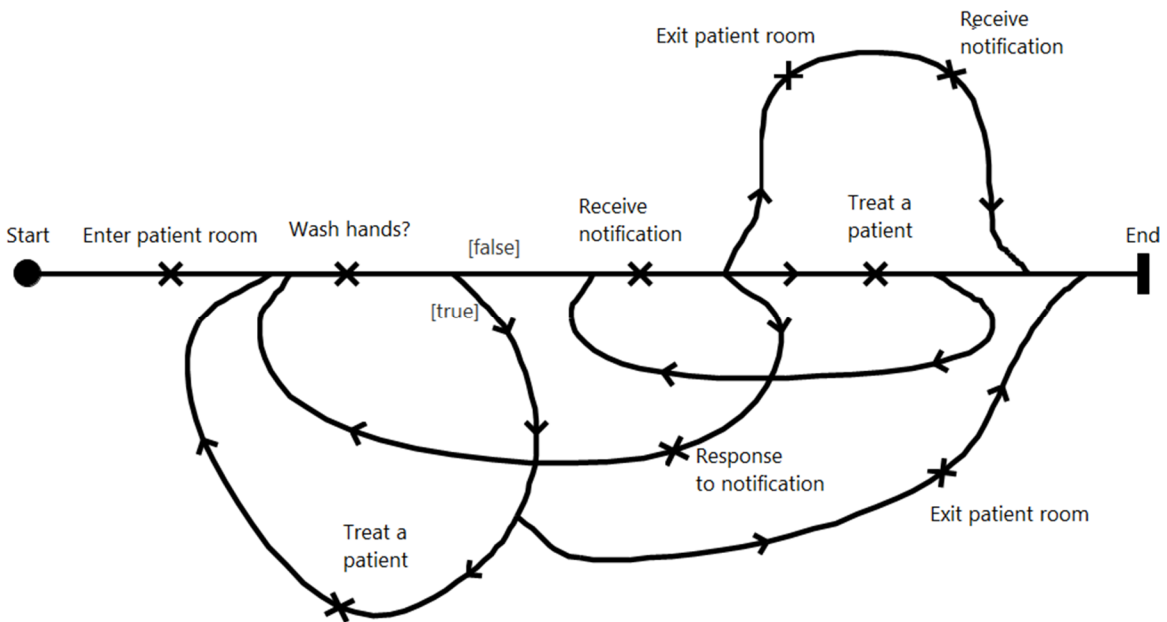

Figure 8 RHMNS scenario model

4.2 System Components

At this level, the structure of the system has been designed and modified many times to solve the problem better and to meet the requirements. Here is the resulting abstract architecture of RHMNS, independent from specific vendor technologies:

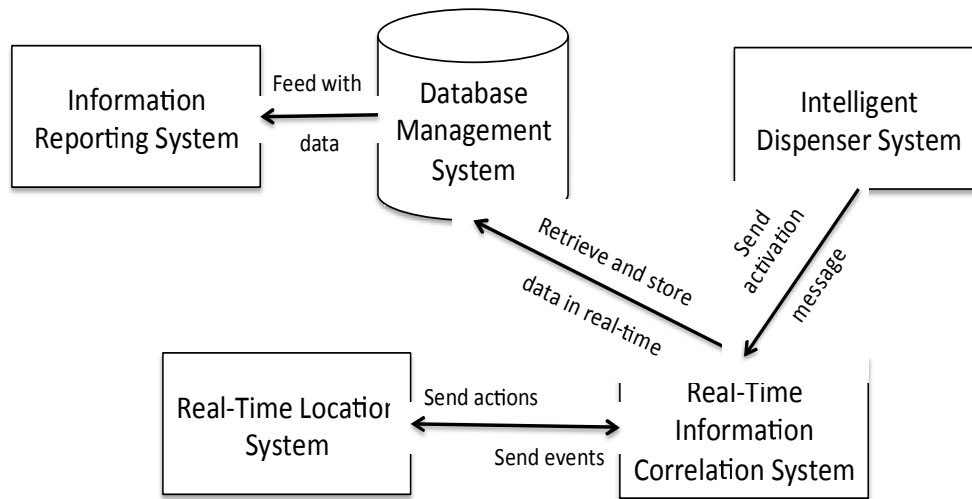

Figure 9 RHMNS abstract architecture

As seen in Figure 9, there are five core components:

- **Real-Time Location System:** this is the unit that tracks HCPs and identifies their current locations. In addition, it generates events and sends actions in real time based on pre-defined rules when needed via sophisticated software and equipment.
- **Intelligent Dispenser System:** this unit is specially designed for the purpose of this study. The intelligent dispenser system sends activation messages wirelessly to another component in the system over the WiFi network when soap is dispensed. The dispenser is original in terms of the way it communicates with other components and in terms of being integrated with an RTLS system.
- **Real-Time Information Correlation System:** this custom-made system mainly links all components together in real time. Additionally, it is responsible for analyzing received data instantly and deciding on HH opportunities, actions and notifications based on defined HH logic.

- **Database Management System (DBMS):** this component is designed to store all data received from the information correlation system and to retrieve data to be used or updated afterward.
- **Information Reporting System:** this component generates informative reports regarding HH compliance trends by analyzing and filtering data stored in our DBMS for off-line analysis, improvement and future strategic plans.

These components are explained in detail in the coming sections.

4.2.1 Real-Time Location System

The general architecture and capabilities of a generic RTLS (illustrated with the Ekahau technology) are explained in section 2.2. However, the main functions of RTLS involve, in our context, tracking HCPs and sending them reminders. In order to accomplish these two tasks, there are four core subsystems that together form the RTLS component in our specific system.

- **WiFi Tags:** these are RFID-based small devices that can send data or receive actions wirelessly over the network. They can be configured to meet the task requirements, for example, to be active or passive tags, to update their locations periodically or when reach IR beacon sensor, to send events when they are being pressed or when motion occurs, etc. Furthermore, they can be configured with information about the network over which they send data or receive actions. Badges are a type of tags used in this study because HCPs carry them to provide location information and to receive reminders.
- **RTLS Server (Controller):** this subsystem is the brain of the RTLS system. This is a (web) service where raw data received from tags is transformed into an understandable data format that represents locations or events. This is also where configuration of tags is set, maps are uploaded, and statuses of equipment can be checked (battery level, last time of update or maintenance, etc.). Additionally, the RTLS server has an HTTP-based API that can be used to change or control anything in the system by coding and receiving/sending from/to a third party component.

- **RTLS Vision:** this component is a web-based application that visualizes the location of devices and people on uploaded maps in real time. Moreover, action can be sent to specific tags or groups of tags once an event occurs. Events are defined by choosing rules from pre-defined rules in RTLS vision. For example, the *Enter Hand Sanitizer Zone* event is based on a rule called *Enter Zone*. When an HCP enters a hand sanitizer zone, an event is received. This event can be sent in real time to pre-assigned e-mails or visualized interactively.
- **RTLS Database:** all received data, events logs, maps, configurations, etc. are stored in this component and can be retrieved when needed.

Figure 10 highlights the RTLS subsystems, instantiated with Ekahau's technology:

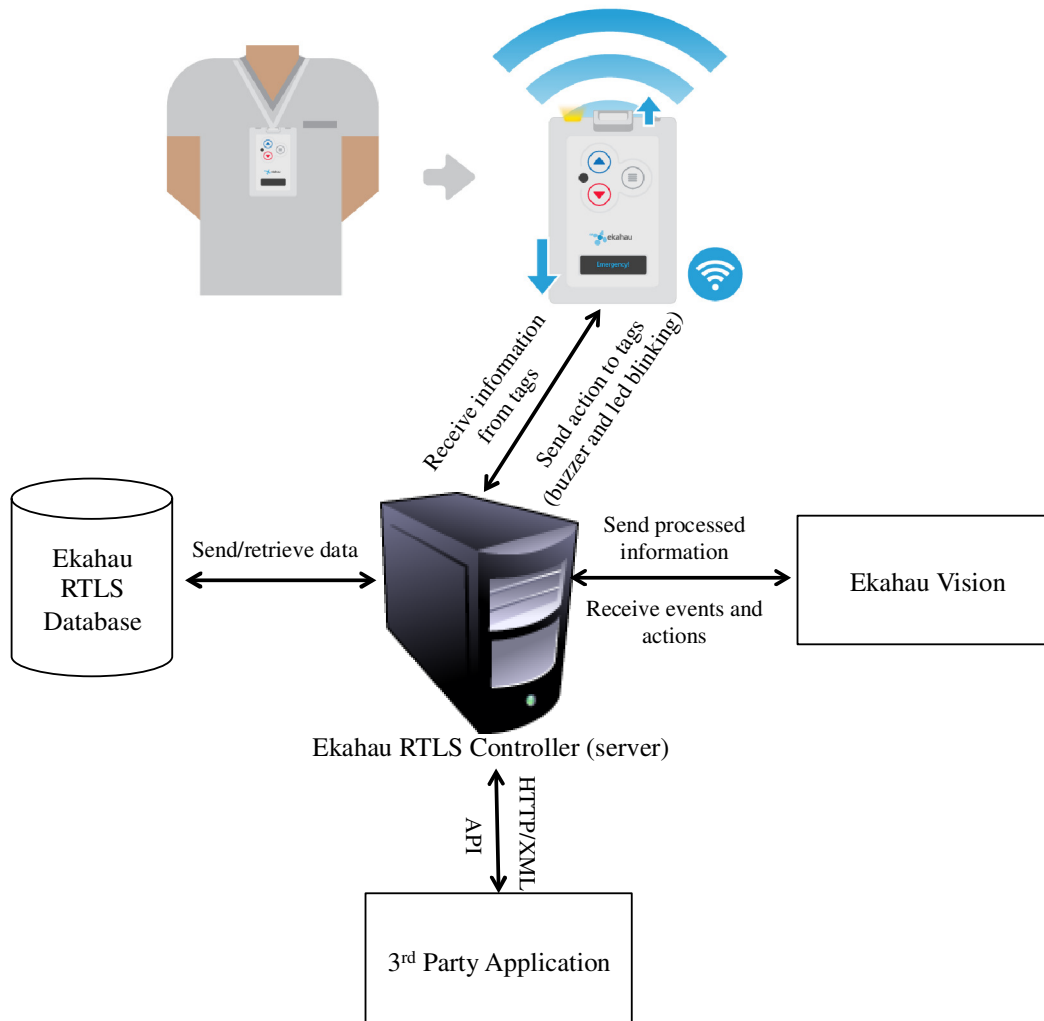

Figure 10 RTLS subsystems

4.2.2 Intelligent Dispenser System

Most soap dispensers do not communicate events over a network. The main idea behind the development of this new type of dispensers is to have dispensers that send activation messages wirelessly and directly to another component in the system when soap, gel, ABHR or other such sanitizing substances are being dispensed. In contrast, dispensers that are integrated into RTLS systems presently transmit IR signals when they are activated. RTLS badges, for example, can read these IR signals, as explained in Chapter 3, to report the act of performing HH.

Having such intelligent dispenser system contributes positively to solving two main issues with existing approaches. The first issue is losing some activation messages while transmitting IR signals to HCP badges. This can happen if an HCP badge is flipped on the other side, which does not have an IR receiver part (hence blocking the line of sight required by IR systems), if the dispensers are located higher or lower than the badge level, or if the badge runs out of battery. Another significant issue is having more than one HCP in a dispenser zone at once. In this case, if one HCP performed HH, all badges of the HCPs present in the zone would receive the same activation message. As a result, this might give false information, as the hands of all HCPs would be considered clean.

In contrast, our proposed intelligent dispenser system overcomes these problems by communicating directly with the core system, which avoids having to transmit anything through (unreliable) badges. In addition, the intelligent dispenser system is an independent component that continues working and interacting with the system even if the RTLS unit is unavailable, which is crucial to keep recording taken HH opportunities and compare them (later on) to the duties of a specific HCP in a patient room, such that estimated compliance numbers are always available. Moreover, our system has a specific approach to handle having more than one HCP in one hand sanitizer zone at once, which will be discussed afterword in section 4.3.

Before discussing the architecture of the final intelligent dispenser system, it is noteworthy to mention our first prototype, used to simulate and test the concept. In this first prototype, an RTLS tag was placed on a regular dispenser's handle, which needs to be pushed to dispense sanitizing substances, as seen in Figure 11. The tag was configured to send an event when its button is pressed. The tag sends the event wirelessly to the

RTLS server and this simulates our proposed intelligent dispenser concept. Following this prototype, the design and implementation phases of the intelligent dispenser started.



Figure 11 The intelligent dispenser: first prototype

A touch-free dispenser made by Gojo, designed to avoid touching the dispenser with hands and spreading infections, was used to implement the idea. The final prototype has four major parts:

- **The microcontroller board** is the main board (Arduino Mega 2516) in which the digital port and the WiFi port are located. The board is programmed and controlled via the Arduino¹⁰ development environment.
- **The WiFi board** transmits and receives signals to/from the microcontroller board via the WiFi port. This is a Hydrogen Arduino WiFi shield board.
- **The switch** is a momentary on/off switch (shown in Figure 14) that is connected to the microcontroller board via the digital port. It sends electronic signals when pressed.

¹⁰ Arduino is “an open-source physical computing platform based on a simple microcontroller board, and a development environment for writing software for the board”. See: <http://arduino.cc>

- **The power system adapter** operates the intelligent dispenser. The power adapter is used instead of batteries to last a few months. Communicating via WiFi signals requires much power; thus, batteries may not work for more than a few days.

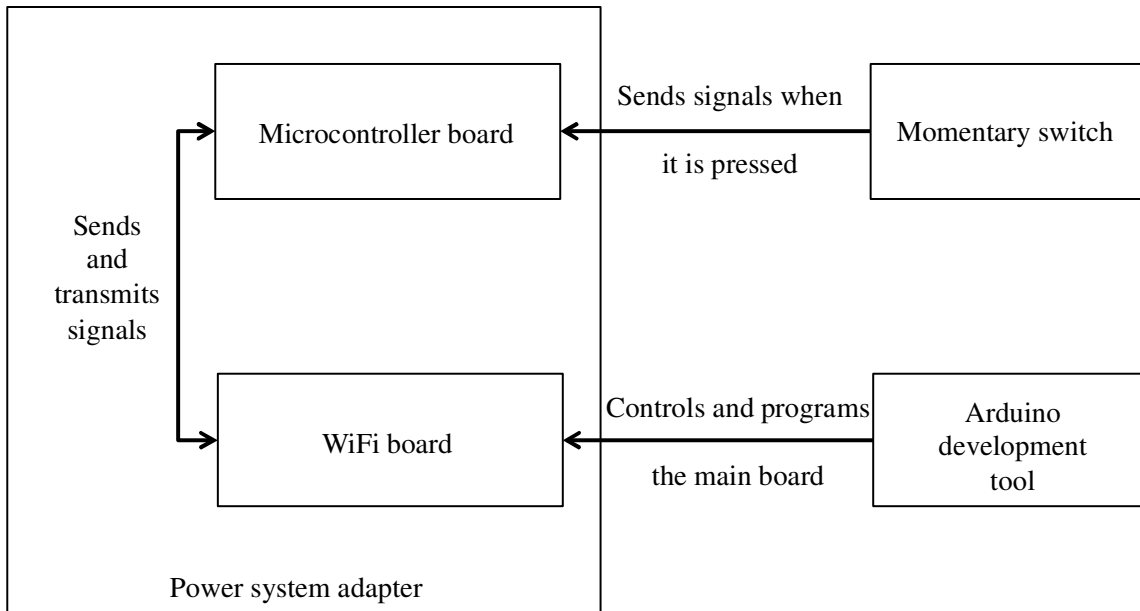

Figure 12 The intelligent dispenser’s system architecture

Figure 12 shows the intelligent dispenser system architecture as explained in the above paragraph. Figure 13 presents the final intelligent dispenser prototype from the outside. The black box on the right side of the dispenser contains the microcontroller board, the WiFi board and its power adapter, while the momentary switch is located inside the dispenser as shown in Figure 14. The switch is mechanically pressed when soap is dispensed by the GoJo device. Another small component was integrated into the dispenser: a LED, used as a system performance status, to help the user troubleshoot problems.



Figure 13 The intelligent dispenser: final prototype



Figure 14 Momentary switch (in the red cycle) placed inside the intelligent dispenser

In a nutshell, the intelligent dispenser subsystem is programmed to send WiFi signals over a local network to a predefined server (using the Transmission Control Protocol – TCP) once it is being activated. It sends structured messages that contain the dispensers’ identifier and how many times a specific dispenser has been used since it was turned on. This intermediate server is further linked to another component (the main application server) to deliver the received data. The concept of the intelligent dispenser has been implemented and demonstrated by Alan Stewart¹¹ and Samer Sader¹², and then integrated into the overall solution by the author of this thesis.

4.2.3 Real-Time Information Correlation System

This part of the system is an application server that receives events from the intelligent dispenser component, receives events from and sends actions to the RTLS component, stores/retrieves data in/from the database, and correlates¹³ received data in real time against the predefined HH detection logic in order to decide on HH compliance. The application server is written in Java because Ekahau’s RTLS SDK is written in Java.

The application server has many functions. The first function is to communicate with the RTLS server. Mainly, this is done by the use of the SDK controller provided by Ekahau’s RTLS. When an event occurs, the RTLS server sends the information about the event to the application server via a pre-written class corresponding to the event. Then, the information about the event (event name, event type, time, date, tag information, etc.) can be extracted as needed from the received class instance to be used either in the HH logic or stored in the database. The following piece of code is an example of an Enter Zone event class:

```
// Called when a new Zone Entered event has been received

public void newZoneEnteredEvent (ZoneEvent pEvent,
                                Device pDevice, LocationEstimate pLocation) {
```

¹¹ Alan Stewart is a computer and electronic instrumentation technologist at the School of Computer Science and Electrical Engineering, University of Ottawa.

¹² Samer Sader is an academic and administrative support specialist at the School of Computer Science and Electrical Engineering, University of Ottawa.

¹³ *Correlation* in our context refers mainly to coordinating and linking multiple sources of information together.

```

// Print something about the received event.

// Get the event information (name, a device that caused the event).
String eventDesc = pEvent.toString() + " --- device: " +
                    pDevice.toString();

// pLocation can be null if the evaluation of the tag's location
has been unsuccessful.
if (pLocation != null) {
    eventDesc += " --- location: " + pLocation.toString();
}

Long timestamp = pEvent.getEventTime();
String deviceName = pDevice.getName();
String zoneName = pLocation.getZoneName();

System.out.println(eventDesc);
}

```

Receiving events from the intelligent dispenser is the second function of the application server. It receives dispense signals from the intelligent dispenser via the intermediate TCP server, as explained in the previous section. The received data is sent to the database to be stored and is checked when entering or exiting a hand sanitizer zone event occurs. Another function of the application server is to communicate with the database in order to store or retrieve data in real time. The application uses a Java Database Connectivity (JDBC) connection to accomplish this task.

There are several HH logic rules that are defined in the application server. The rules are:

- 1- If an HCP enters a patient room and did not wash his/her hands within 60 seconds, a *buzzer* (vibration with an audible alert accompanied by change in the LED color) will be sent to his/her badge.
- 2- If an HCP enters a patient room and goes directly to a patient bed zone, a buzzer will be sent to his/her badge.
- 3- If an HCP did not wash his/her hands before moving to another patient bed zone in the same room, a buzzer will be sent to his/her badge.
- 4- If an HCP exits a patient room and did not wash his/her hands, a buzzer will be sent to his/her badge.
- 5- If there are more than one HCP in a hand sanitizer zone at once and if the number of HCPs is less than the number of the intelligent dispensers' activation messages

received when one of the HCP gets out the zone, a buzzer will be sent to the badges of all HCPs involved.

The last case is conservative but is required, otherwise a buzzer would not be sent to the badges of MCPs with missed HH opportunities.

The following is an example of HH logic. When a new *Entered Zone* event has been received, the following code checks whether there is an HH opportunity to be taken and whether the HCP missed it. The code investigates all possible HH opportunities if the entered zone was a patient environment (a patient bed zone).

```
// PE means Patient Environment
if (EnteredZoneType.contains("PE")) {

// First, check the type of the last zone entered by the HCP

    if (lastEnteredZoneType.contains("PE")) {

// If last entered zone type was a patient environment, then check
// if the current entered zone is the same as the last entered one. If
// it is not, then send a buzzer to the HCP because they moved from a
// patient environment to another without performing HH.

        if (!LatestEnteredZoneName.contains(CurrentZoneName)) {
            SendBuzzer(HPMac);
        }

// Store data in database: Room ID, HCP badge MAC, date, zone name,
// Hand washing confirmation, and buzzer status.

        DataBase.InsertNewRecord(RoomId, HCPMac, date,
            CurrentZoneName, 0, true);
    }

    else {
        DataBase.InsertNewRecord(RoomId, HCPMac, date,
            CurrentZoneName, 1, false);
    }

else if (!lastEnteredZoneType.contains("HS")) {

// This includes any zone other than hand sanitizing (HS) zones
// or patient environment zones.

        SendBuzzer(HPMac);
        DataBase.InsertNewRecord(RoomId, HCPMac, date,
            CurrentZoneName, 0, true);
    }

else if (lastEnteredZoneType.contains("HS")){

// Retrieve data from the database about the HCP washing hands in
// the last entered zone that is a hand sanitizer.
```

```

if (DB.HandwashingConf.GetHWC(HPMac).contains("0")) {
    SendBuzzer(HPMac);
    DataBase.InsertNewRecord(RoomId, HCPMac, date,
        CurrentZoneName, 0, true);
}

else {
    DataBase.InsertNewRecord(RoomId, HCPMac, date,
        CurrentZoneName, 1, false);
}
}
}}

```

4.2.4 Database Management System

Figure 15 represents the database schema of data received from the RTLS side and from the intelligent dispenser side:

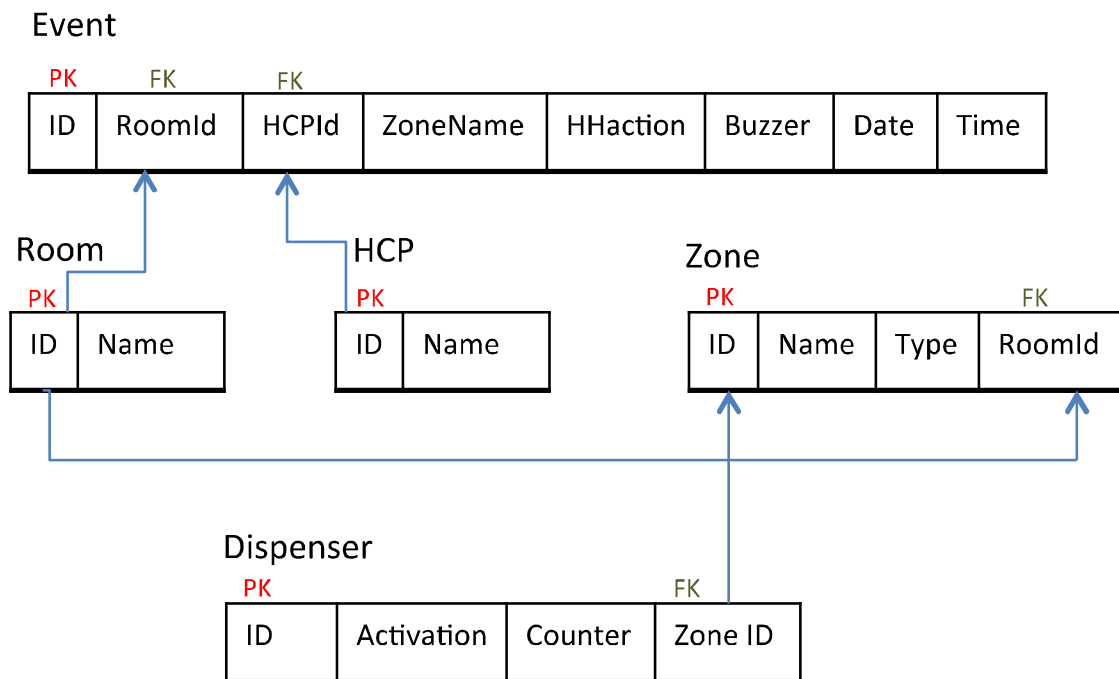

Figure 15 Database schema of received data in real time (PK = Primary Key, FK = Foreign Key)

As shown in the previous figure, there are five tables:

- **Event table:** the main purpose of this table is to store events as they occur in real time. Thus, RHMNS can check the latest received event before the current event for a specific tag, for example, each time it needs to decide on HH opportunities

or missed HH opportunities (as explained in the previous code sample). Table 3 explains the table attributes and their functions.

Table 3 Event table details

Attribute	Type	Function
ID	Integer	The primary key.
RoomId	Integer	To store where an event takes place (foreign key).
HCPId	Integer	To store who caused to happen the event (foreign key).
ZoneName	Varchar ¹⁴	To store the current entered zone name, in some cases to retrieve the latest entered zone before the current one.
HHAction	Integer	To store the number of taken HH actions when an HCP enters a hand sanitizer zone and is checked when an HCP enters other zones.
Buzzer	Boolean	To store the buzzer status.
Date	Varchar	To store the date at which the event occurs.
Time	Long	To store the time at which the event occurs.

- **Room table:** this table is designed to store information on rooms in hospitals. It has two attributes: ID, which is the primary key of type integer, and name, which is of type varchar to store names of rooms.
- **Zone table:** this table is designed to store information on zones inside rooms. It has four attributes: ID, which is the primary key of type integer; name, which is of type varchar to store names of zones; type, which is of type varchar, that can be for one zone one of Hand Sanitizing (HS), Patient Environment (PE), Room or Corridor type; and RoomId to link zones to their rooms (foreign key).
- **HCP table:** this table is meant to store information of HCPs in RTLS system. It has two attributes: ID, which is the primary key of type integer, and name, which is of type varchar to store virtual names of HCPs such as nurse1 (not their real information for privacy purpose).

¹⁴ Varchar is a data type in SQL server 2008 for strings. It is an acronym for variable (length) character.

- **Dispenser table:** this table exists to store intelligent dispensers IDs, which are the primary key, activation as a confirmation of something being dispensed, counter, and zones IDs where these dispensers are located (foreign key) all of type integer.

The Event and Dispenser tables are filled and updated in real time while the others are static tables filled when deploying the system or when there are updates to the environment or personnel (Room, HCP and Zone tables). It could be argued that having ZoneName in the Event table is unnecessary as zone names and types could be retrieved from the other tables and the logic could be done instantly in the application server. However, ZoneName is playing a significant role in terms of checking the previous zone event before the current event for a specific HCP, which is important for the HH algorithm to work properly (as shown in the above code).

An interesting point to mention is related to the Counter field in the Dispenser table. Counter here counts how many HCPs were in the same zone of a specific dispenser, and Activation represents the number of uses of the dispenser. These two attributes, together with data stored in the Event table, help making the decision about performing HH. On the other hand, the three static tables participate mainly in generalizing the code. Instead of relying on zone names or IDs received from the RTLS server and of defining them in the application server, which would lead to code duplication, the system receives zone names from the RTLS server, checks their types in the database, and continues checking the rules based on the retrieved types. Consequently, the number of code lines is reduced significantly and adopting new changes or deploying the system in a huge hospital will be more efficient and easier to maintain.

4.2.5 Information Reporting System

This component aims to analyze and present the collected data into meaningful forms. It has to generate reports and deliver them to appropriate hospital stakeholders. EazyBI¹⁵ is the web-based business intelligence tool that has been chosen for supporting this task. The tool has several features that facilitate integrating data from many resources and pub-

¹⁵ <https://eazybi.com>

lishing dashboards, without the inherent complexity of more advanced tools such as the IBM Cognos Business Intelligence tool¹⁶.

In terms of data integration, the tool can import data from different sources, for example: from MS Excel Comma-Separated Value (CSV) documents directly, from data warehouses or from applications via connections. EazyBI stores a copy of the imported data into its local database to facilitate processing the data in the end-user web browser. Through the browser, the user can analyze the data by defining filters or equations, or present the data by choosing a group of fields or a specific period of time. In addition, the user can create reports by using the analyzed data and can create several types of charts (e.g., line chart, bar chart, pie chart, etc.). Then, the user can create dashboards and send them by email or schedule a time for them to be sent. Moreover, dashboards can be exported as PDF documents or as HTML pages to be used in other applications. Privacy is one of the most important features that the tool supports. The user can set his account to private and share the data with specific users to keep it only for themselves. Figure 16 shows the architecture of EazyBI.

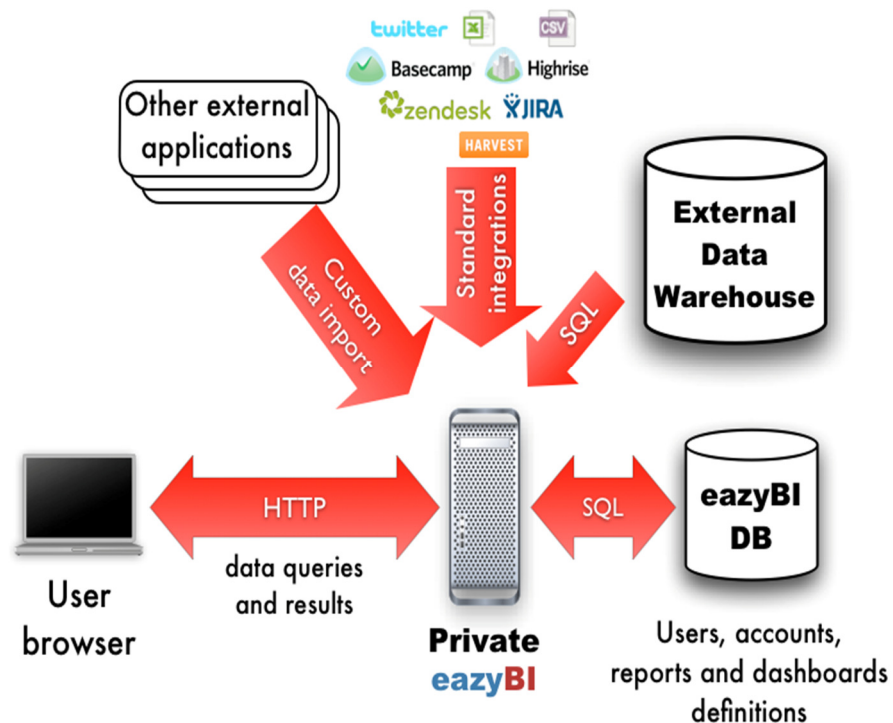

Figure 16 EazyBI architecture (EazyBI's website, 2014)

¹⁶ <http://www-03.ibm.com/software/products/en/business-intelligence>

In our case, a connection between EazyBI and our database has been created to import the data through the use of SQL queries. Then, some filters have been defined to filter the data according to different factors (time, HCP, taken HH opportunities, etc.). Finally reports that have information about HH compliance were created and emailed to some addresses. Figure 17 shows a sample of a created line graph about collected data during the experiment period (June 2014). A more complete HH compliance report is illustrated in Appendix B.

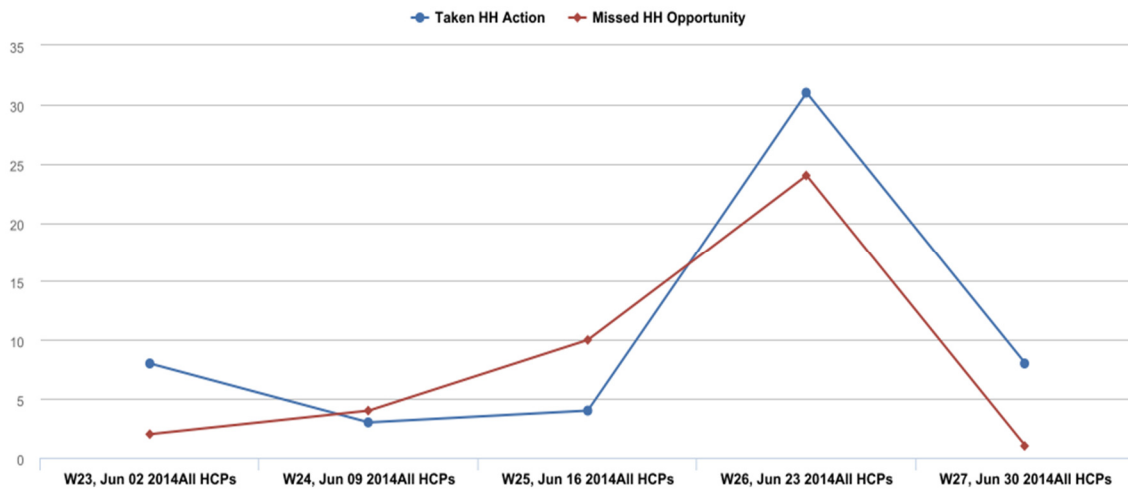

Figure 17 A sample of overall weekly HH performance in June 2014.

The reporting information component can create many types of reports based on the data in our database, such as:

- HH compliance of a specific HCP, a group of HCPs or all HCPs over a day, a week, a month and a year.
- Specific numbers of taken or missed HH opportunities by HCP or for all of them.
- Specific number of sent reminders to an HCP or all them in a specific period of time, compared with the number of missed HH opportunities.
- Statistics on who practice HH better among nurses, doctors or physicians.
- Sanitizing areas that are used often to practice HH.
- Most forgotten moments of practicing HH.
- Detailed records (time and date) of enter/exit zones in a patient room of HCPs.

4.2.6 RHMNS Detailed Architecture

A more detailed architecture representation of all RHMNS subsystems, with the specific technologies used in the experiments, is summarized in Figure 18.

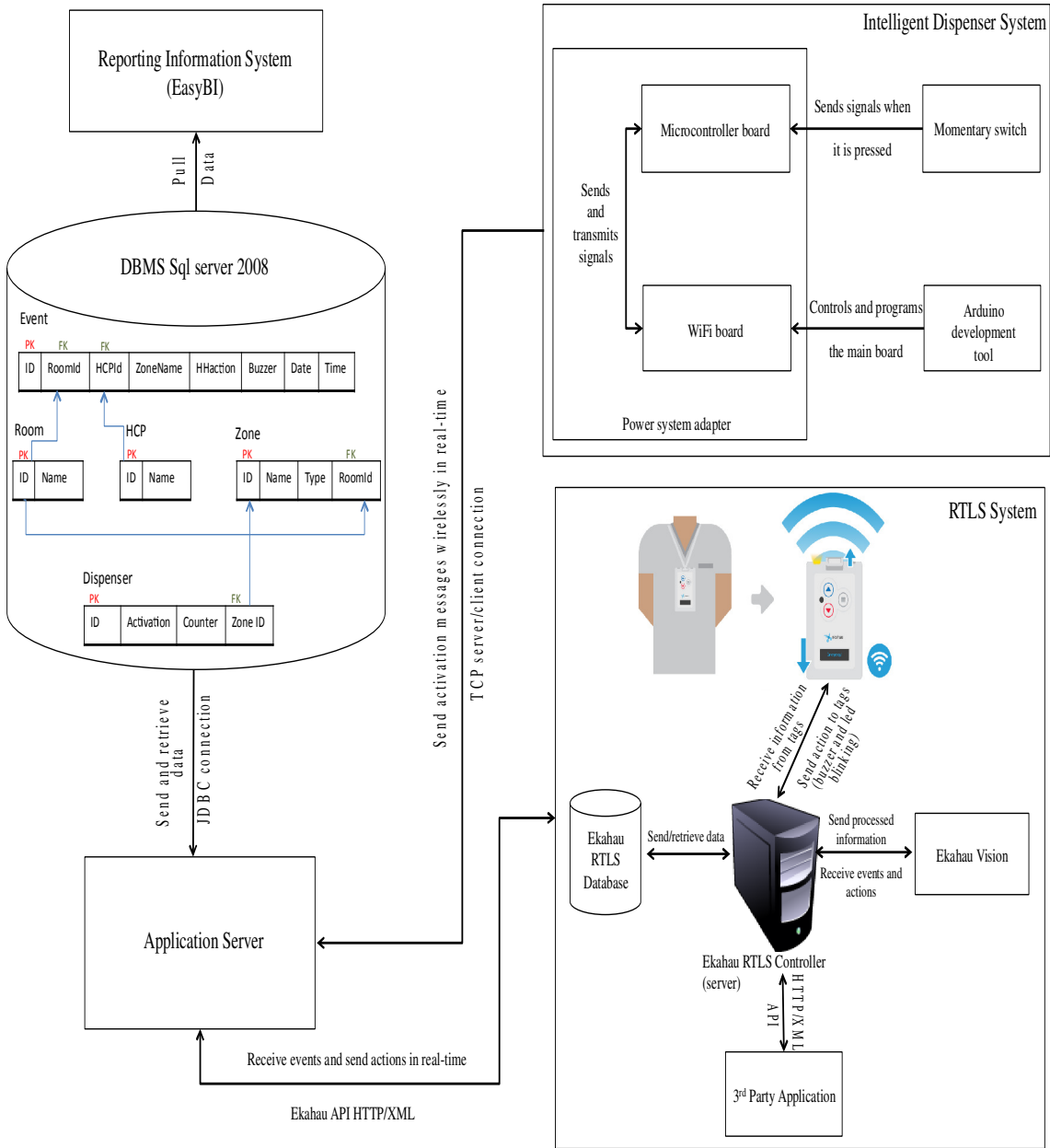

Figure 18 RHMNS detailed architecture

4.3 RHMNS Approaches

There are two approaches that have been designed based on the general architecture of RHMNS: a *time-based approach* that relies on the time spent in front of a hand sanitizer, and an *activation-based approach* that is based on receiving explicit activation messages from an intelligent dispenser system to decide whether HCPs have performed HH or not.

4.3.1 Time-based Approach

The system tracks HCPs at regular time intervals (every 5 seconds). It determines that an HCP did not wash his/her hands if an appropriate *enter hand sanitizer zone* event was not received: i) within 30 seconds of receiving an *Enter Patient Room* event, ii) before receiving an *enter Bed Zone* event, iii) before receiving an *Exit Room* event, or iv) if the time spent in the hand sanitizer zone was less than 15 seconds (minimum time for performing HH action using alcohol-based hand rub). In such cases, the system sends a buzzer and audible alert to the HCP badge, as a reminder. This approach has been developed under the request of the TOH group to be an appropriate alternative to the other approach if the latter was too costly (or impossible) to implement.

4.3.2 Activation-based Approach

This approach is logically similar to the time-based approach, but with a significant addition. The core idea is to use the intelligent dispensers to send events wirelessly when dispensers are being activated (instead of waiting, as HCPs seldom stay near a dispenser while washing their hands). The decision regarding hand washing is hence based on concrete evidence (sanitizer being dispensed) rather than inferred based on a duration (without evidence that sanitizer was dispensed).

There are two different categories of situations covered by this system: the *One-HCP* case, where there is only one HCP in the hand sanitizer zone, and the *Multi-HCP* case, where there are many HCPs in the zone. In the One-HCP case, the system recognizes precisely who performed the hand hygiene action. In the Multi-HCP case however, it becomes challenging for the system to determine who used the dispenser and who did not, and to which badges notifications should be sent. In this latter case, the system counts the number of HCPs that are in the hand sanitizer zone at the same time and the

number of times that the dispenser has been activated. If the number of times the dispenser was used is less than the number of HCPs, the system takes a conservative approach and sends notifications to *all* HCP badges involved. Otherwise, the system assumes that all HCPs performed proper hand hygiene actions.

4.4 Chapter Summary

This chapter discussed the unique architecture of RHMNS. Each component of the system (RTLS system, the intelligent dispenser system, DBMS and reporting information system) was explained in detail. The two approaches exploiting RHMNS that were designed to assess HH compliance based on either time or activation messages sent from the intelligent dispenser system were explained as well. The next chapter will present the experimental validation of RHMNS and will discuss major points to consider before deploying such system in hospitals.

Chapter 5. Testing and Validation

This chapter presents an experiment conducted on RHMNS to validate it and to test the system's ability to perform under certain conditions. It highlights the different phases of the experiment starting from the design of the evaluation strategy to the discussion of the obtained results. It also shows interesting observations noticed while testing the system as well as challenging issues still to be faced.

5.1 Proof-of-Concept Demonstrations

Before formally evaluating RHMNS, two proof-of-concept demonstrations were given to a TOH group and to some academic staff at the University of Ottawa while designing and implementing the system. The first demonstration was held in a laboratory at the University of Ottawa in November 2013. The main objectives of this demonstration were to i) show the capability of RHMNS to track a single HCP and to decide on HH opportunities based on entered zones (with the use of the first dispenser prototype to simulate the functionalities of the intelligent dispenser illustrated in Figure 11), and ii) gather feedback from TOH collaborators on what was presented. The feedback was positive and encouraged us to go further with the project.

The second demonstration was more demanding and valuable than the first one because while the first demonstration was done in a lab, the second one was done in a real environment at TOH, with more advanced features of RHMNS. A patient room with two real beds was given to us to prepare for the demonstration, as seen in Figure 19 (Room B403 at TOH, equipped with RHMNS equipment). The main objective of the demonstration was to showcase the idea of notifying HCPs when needed, to demonstrate a *Multi-HCP* scenario and to test the fully designed architecture of RHMNS. Surprisingly, we encountered many challenges, most of which related to hardware. One of them is that the signal strength of the wireless network was weak in that area; therefore, the performance of the system was affected negatively. The badges could not update their cur-

rent location in a reasonable amount of time. The performance of badges was not just affected by the weakness of signals, but also by the frequent and constant use of specific badges, which required much power and recharging, and by the crowd on the floor. On some days, the badges stopped working and they could not communicate with the RTLS server. However, the system was behaving well after 6pm.

Despite these challenges, a successful demonstration was delivered that covered all system requirements, and we received the blessing of our collaborators on what was presented. After that demonstration, RHMNS was ready to move to the next step, which involved more rigorous validation and testing.

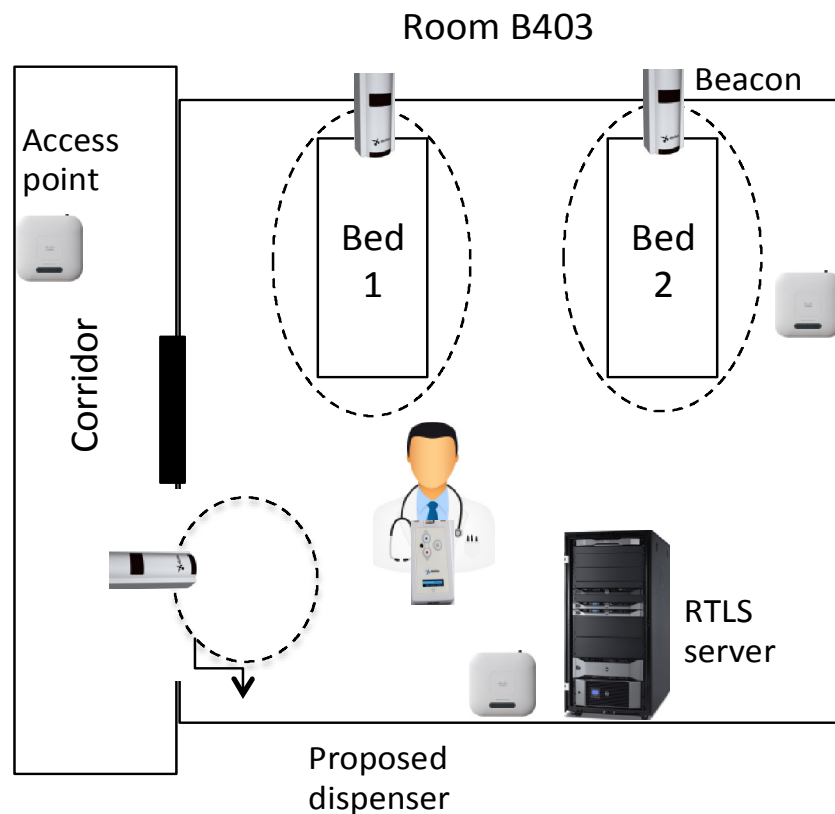

Figure 19 Room B403 at TOH equipped with RHMNS equipment for the second demo

5.2 Evaluation Strategy

In this section, the strategy behind RHMNS's evaluation is discussed. Firstly, some important criteria were chosen to evaluate RHMNS. Then, a scoring system was designed to suite the evaluation process and the two approaches exploiting RHMNS. Then, potential

scenarios were selected to test the system; these scenarios aim to cover of our requirements and the different types of HH moments. The test scenarios were repeated many times to obtain statistics on the results. These phases are discussed in detail in the following sub-sections.

5.2.1 Criteria

Based on the requirements discussed in Chapter 4 and the problem context discussed in Chapter 1, there are some of criteria that crucially affect the usefulness of RHMNS and impact strongly the decision of whether to adopt the system in hospitals. The criteria are explained below, in no particular order.

- **Robustness:** this criterion is for testing the ability of RHMNS to perform robustly under any condition. As shown in section 5.1, it is possible for RTLS systems to be affected by environmental conditions, for example by the number of people around and other sources of noise and interference, and by the signal strength of wireless networks. In addition, using the same badges for a long period of time may affect the RTLS system as well. Such factors could have a negative impact on the way that RTLS equipment communicates (tags to RTLS server or vice versa). As a result, sometimes the system crashes, which requires shutting down all system components, while other times it stops responding or takes a longer time to respond than it normally takes. System failures and delays are two major concerns in terms of system robustness, so they were investigated closely while performing the validation process.
- **Accuracy:** this criterion investigates how accurate RHMNS is regarding the detection of current HCP positions. This measurement has a considerable impact on the next criterion (precision of decision).
- **Precision:** this is the most important criterion to be investigated. It measures how precise the system is in terms of making decisions on HH missed opportunities or taken actions, which is one of the core objectives of RHMNS. Consequently, to validate the precision of decision, a confusion matrix is defined (Table 4, with true positives, true negatives, false positives and false negatives) to acquire important metrics:

- *precision* ($TP / (TP + FP)$)
- *recall* ($TP / (TP + FN)$)
- *f-measure* ($2 \times \text{precision} \times \text{recall} / (\text{precision} + \text{recall})$)

Table 4 Confusion matrix

	Positive	Negative
True	Washed-no buzzer (TP)	Not washed-buzzer (TN)
False	Washed-buzzer (FP)	Not washed-no buzzer (FN)

- **Response time:** the crucial factor in any RTLS is time. In our context, a few seconds of delay can significantly affect the decision of notifying HCPs or the decision based on performing HH actions. In this criterion, the time taken by RHMNS to generate events when entering zones and sending buzzers, and the time taken by the intelligent dispenser to send activation messages, are recorded and calculated to help assessing whether RHMNS is performing well in terms of timing.
- **Privacy:** an important point to ensure is not to threaten HCPs' privacy. Their personal information shall not be known or stored and their movements outside patient rooms and corridors shall not be tracked.
- **Deployment:** this one is meant to measure whether all requirements need to be fulfilled when deploying RHMNS: hardware setup, database configuration, etc.

It is important to mention that there were no explicit non-functional requirements provided by TOH collaborators to clarify what is the target value of each criterion. The stakeholders do not have a clear understanding at this time about what values would be acceptable to users. Our system can hence as a prototype environment to determine useful target values in the future.

5.2.2 Scoring System

The selected scoring system associates a weight to each criterion based on its importance. The final score for each criterion will be the product of its observed score by this weight. The scale for weights goes from 1 to 5 and the non-weighted scores from 0 to 3. The final

score for each approach will be obtained by adding all scores of all criteria for each approach separately (weighted sum). Table 5 describes the quantitative scores their corresponding qualitative interpretation.

Table 5 Scoring system values

Qualitative values	Quantitative values
Fully satisfied	3
Satisfied	2
Weakly satisfied	1
Rejected	0

Each criterion needs to have its own scoring range that eventually will be matched to its quantitative values (see Table 6 to Table 9):

Table 6 Precision of decision scores

Score in percentage	Equivalent score	Weight	Total score
100%-95%	3	5	15
94%-90%	2		
89%-85%	1		
84% and less	0		

Table 7 Robustness scores

Score in percentage	Equivalent score	Weight	Total score
100%-95%	3	4	12
94%-90%	2		
89%-85%	1		
84% and less	0		

Table 8 Accuracy of positions scores

Score in percentage	Equivalent score	Weight	Total score
100%-95%	3	3	9
94%-90%	2		
89%-85%	1		
84% and less	0		

Table 9 Response time scores

Seconds	Equivalent score	Weight	Total score
0-5	3	3	9
6-8	2		
9-10	1		
More than 10	0		

The weight of privacy is 2 and of that of deployment is 1 (their final maximum scores are 6 and 3 respectively), and their scores will be assessed in the preparation phase.

5.2.3 Scenarios

As explained in section 4.1.4, there are scenarios and behaviours of HCPs expected in terms of performing HH. In order to test how well RHMNS handles these scenarios, several precise scenario instances have been carefully designed 1) to cover all scenario paths in the Use Case Map model of Figure 8, and 2) to simulate the simplicity and the complexity of real scenarios running in hospitals. Basically, complex scenarios are a combination of multiple simple scenarios that together make a real reasonable scenario. The number of designed simple scenarios was relatively high (around 13 based on the coverage of the Use Case Map model of Figure 8 and of requirements related to the handling of multiple HCPs) for the validation process. This number was reduced to 4 by combining some scenarios into more complex ones. The scenarios, which involve two nurses and two beds in a room, are as follows:

1- Best case scenario (no buzzer)

- a. Nurse 1 enters room 1.
- b. Nurse 1 goes to hand sanitizer zone.
- c. Nurse 1 washes her hands.
- d. Nurse 1 goes to bed 1.
- e. Nurse 2 enters the room.
- f. Nurse 2 goes to hand sanitizer zone.
- g. Nurse 2 washes her hands.
- h. Nurse 2 leaves the room.
- i. Nurse 2 enters the room again.
- j. Nurse 2 goes to hand sanitizer zone.
- k. Nurse 2 washes her hands.

- l. Nurse 2 goes to bed 1.
- m. Nurse 1 goes to hand sanitizer zone.
- n. Nurse 1 washes her hands.
- o. Nurse 1 leaves the room.
- p. Nurse 2 goes to hand sanitizer zone.
- q. Nurse 2 washes her hands.
- r. Nurse 2 leaves the room.

2- Worst case scenario (no HH action)

- a. Nurse 1 enters room 1.
- b. Nurse 1 goes to bed 1 (should receive a buzzer).
- c. Nurse 2 enters the room.
- d. Nurse 2 spends 30 seconds not going to any zone (should receive a buzzer).
- e. Nurse 2 leaves the room (should receive a buzzer).
- f. Nurse 2 enters the room again.
- g. Nurse 2 goes to bed 1 (should receive a buzzer).
- h. Nurse 1 leaves the room (should receive a buzzer).
- i. Nurse 2 goes to hand sanitizer zone but does not washes her hands.
- j. Nurse 2 leaves the room (should receive a buzzer).

3- Mixed Scenario 1

- a. Nurse 1 and nurse 2 enter room 1.
- b. They go to a hand sanitizer zone.
- c. They wash their hands.
- d. Nurse 1 goes to bed 1 while nurse 2 goes to bed 2.
- e. Nurse 1 goes to bed 2 (should receive a buzzer).
- f. Nurse 1 leaves the room (should receive a buzzer).
- g. Nurse 2 goes to a hand sanitizer zone.
- h. Nurse 2 washes her hands.
- i. Nurse 2 leaves the room.

4- Mixed Scenario 2

- a. Nurse 1 enters room 1.
- b. Nurse 1 spends 30 seconds not going to any zone (should receive a buzzer).
- c. Nurse 1 goes to a hand sanitizer zone.
- d. Nurse 1 washes her hands.
- e. Nurse 2 enters the room.
- f. Nurse 2 goes to the hand sanitizer zone.

- g. Nurse 2 washes her hands.
- h. Nurse 2 goes to bed 2.
- i. Nurse 2 goes back to the hand sanitizer zone.
- j. Nurse 2 leaves the room without washing her hands (both nurses should receive buzzers because the system takes a conservative approach).
- k. Nurse 1 washes her hands.
- l. Nurse 1 goes to bed 2.
- m. Nurse 1 leaves the room (should receive a buzzer).

These scenarios are meant to have more than one event happening at once to test the importance of having the system response fast with the correct responses, at the same time. In other words, it shows the negative impact of RHMNS on monitoring HH compliance and notifying HCPs in case the system misbehaved with unacceptable delays, wrong decisions, wrong identifying of positions or no response at all. They are meant to show the worst and the best of the system, and mixed situations.

5.2.4 Test Setup

It is important to test RHMNS from two different angles: 1) usefulness of its architecture and its HH algorithm, and 2) the validity of the system to be adopted in a real healthcare environment. For testing the first part, the four designed scenarios are repeated 30 times for both approaches (activation-based approach and time-based approach) in a slow rhythm (SR). Slow rhythm means waiting for one event to happen before moving to another one in the same scenario; for example, waiting for receiving the *Enter Bed 1* event before entering bed 2 to make sure that the system did not miss capturing any event that could affect the evaluation of the designed architecture or HH algorithm. In addition, a quick testing rhythm (QR) has been used to simulate the rush that HCPs are always in and a more realistic healthcare environment. The same scenarios have been repeated 20 times for both approaches with no consideration for missing or late events. The numbers of times the scenarios were repeated using both rhythms may increase if the systems (e.g., WiFi) are fluctuating in terms performance.

5.3 Preparation

This part presents three preparation steps that should be done before starting the testing and validation.

5.3.1 Lab Setup

The experiment was conducted in a laboratory at the School of Information Technology and Engineering building of the University of Ottawa. The laboratory (room 4-051) was set up to simulate a similar room at the hospital (two beds, a sink zone and a dispenser zone). Five beacons were configured to micro-zone mode (each covering at most a small zone such as a hand sanitizer zone) and were located in each monitored zone (bed 1, bed 2, a dispenser zone, entrance of the room and corridor). Two access points were connected to the main router of the local network that was connected to the RTLS server, and they were located at three different heights to have good triangulation and accuracy. The prepared laboratory is shown in Figure 20.

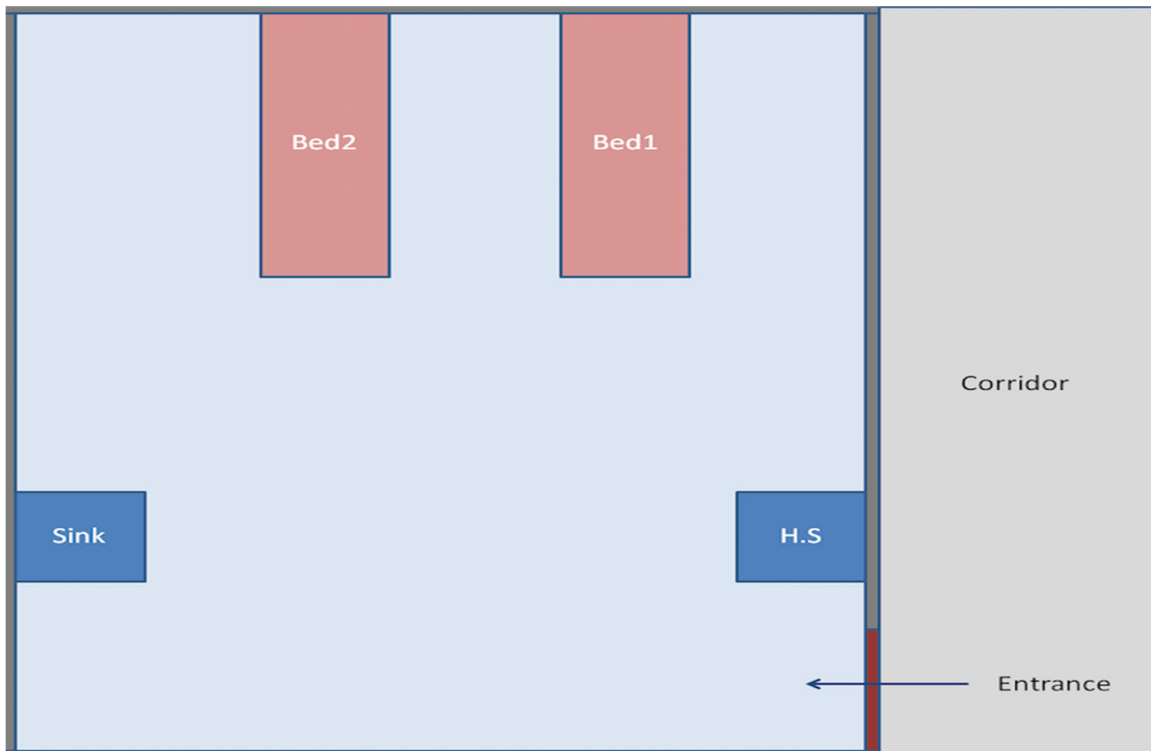

Figure 20 The simulated patient room (university laboratory)

5.3.2 Software Configuration (Map, Events, Database)

There is a need for configuring three parts of the software used here. Firstly, the map of the simulated patient room in the laboratory must be drawn using Ekahau's Site Survey tool, as shown in Figure 21, in order to provide the RTLS server with the location information model (*positioning model*). This model is required by the RTLS server to identify the location of tags accurately. Secondly, a set of rules should be defined in Ekahau's Vision tool to generate events when the rules' conditions are satisfied. For example, the *Enter Bed1* event will be generated when a rule named *Enter Area* is activated (the condition of this rule is satisfied in case the area defined as the Bed1 zone sees an HCP entering it). Lastly, the database has to be updated with the new map information (name of zones) and the new badge IDs if there were new ones.

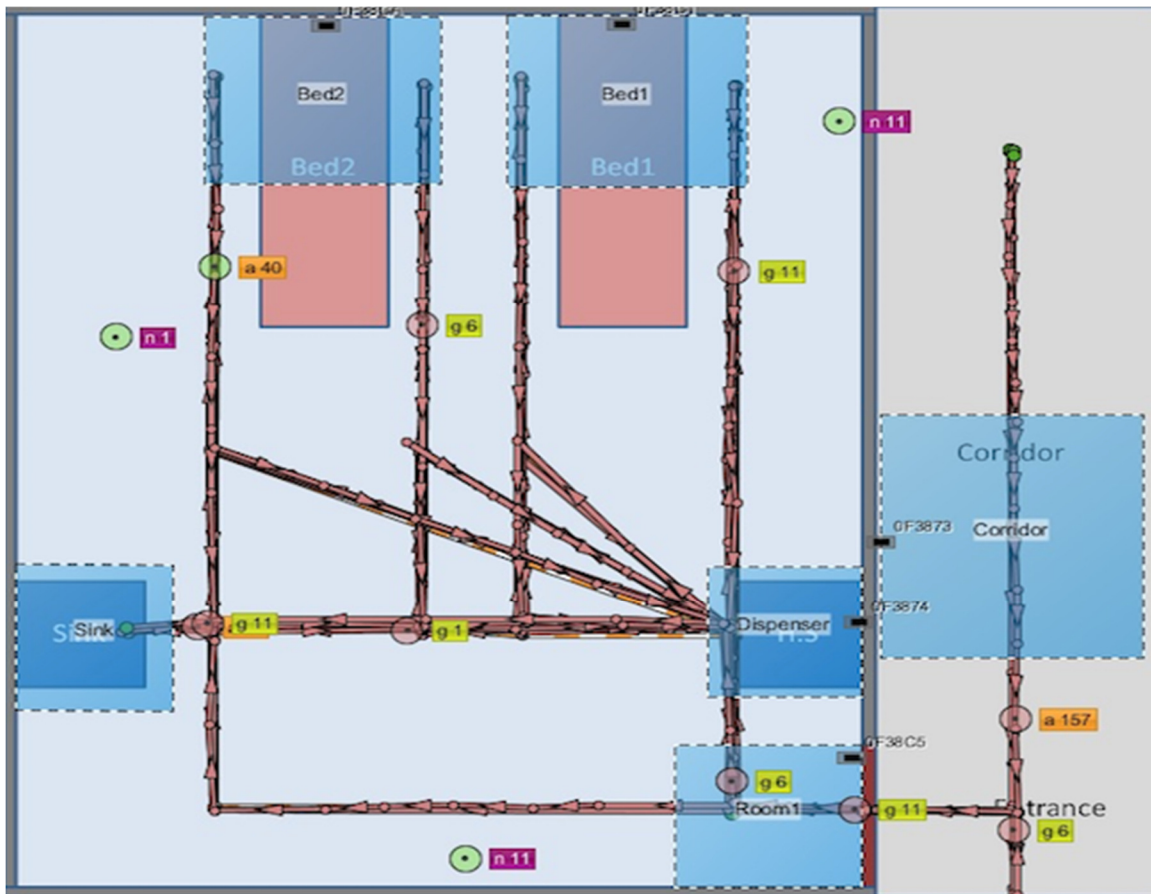

Figure 21 Map of the simulated patient room in Ekahau's Site Survey tool

By the end of this step, the privacy and deployment criteria can be evaluated. In terms of privacy, RHMNS does not allow anyone to have access to the collected data but the

authorized administration staff as log in (username and password) is needed before one can start using the system. The system does not track HCPs outside of patient rooms and corridors. In addition, real information of HCPs is never known; all data stored in the database system is about the badges (physical MAC address and type of HCP: physician, nurse, doctor, etc.). The score for privacy is 3, fully satisfied.

Moving to the second criterion (deployment), if any hospital wants to adopt RHMNS or if it has already been equipped with the system but it needs to expand it to cover more areas, all steps under this section (5.3) should be done/repeated. Equipping the new area with hardware, drawing or adding a new map, defining new rules based on the new map and configuring the database should be repeated. Hence, deploying RHMNS is not difficult but it is time-consuming and still requires tedious work. RTLS tools are currently not smart enough to update themselves automatically based on new changes. The score for deployment is 1, i.e., weakly satisfied.

5.3.3 Test Preparation

Each expected and designed scenario was tested individually before running the experiment to ensure that the system logic is working as required and that the equipment is working properly and configured correctly.

5.4 Test Implementation and Execution

The four scenarios have been implemented and were tested 30 times for each approach (activation-based and time-based) using a slow rhythm, in our laboratory setup (Figure 20). The first part of the experiment did not go further than 30 repetitions for each approach individually because the behaviour of the system became predictable and identical since round number 15 for the activation-based approach and since round number 12 for time-based approach. Then, the second part involved repeating the selected scenarios 20 times for each approach, this time using a quick rhythm. The process of validating and testing RHMNS was performed over four consecutive weeks and during three different parts of the day (morning, afternoon and evening), to mitigate bias caused by using a single time of the day or a single day in terms of having people and other interference sources around. Numbers, observations, awkward and interesting behaviour of the system

were collected and will be discussed in the coming sections. The experiment sheet used to collect data for each test run is included in Appendix C.

5.5 Results

Table 10 shows the obtained scores in percentage of success for each criterion after evaluating each approach individually. These scores represent the average of RHMNS performance during the validation test.

Table 10 Mean results of the evaluation process

Systems	Criteria										
	Robustness		Accuracy			Decision Precision			Response time		
	Crash down	No response	Correctly detected	Incorrectly detected	Not detected	Recall	Precision	F-measure	Event	Buzzer	Dispenser
Activation-based SR	0%	20%	95%	2.5%	1.8%	80%	95%	87%	5 sec	1 sec	1 sec
Time-based SR	0%	20%	95%	4%	1%	88%	98%	93%	4.5 sec	1 sec	1 sec
Activation-based QR	0%	0%	99%	1%	0%	100%	97%	98%	4 sec	1 sec	1 sec
Time-based QR	0%	10%	87%	7%	5%	79%	92%	85%	3.5 sec	1 sec	1 sec
Total	0%	12.5%	94%	3.6%	2%	87%	96%	91%	4 sec	1 sec	1 sec

Table 11 Mean results of the evaluation process based on the scoring system

Criteria	Weight	Scores		Evaluation	
		Activation-based	Time-based	Activation-based	Time-based
Robustness	4	8/12	4/12	Satisfied	Weakly satisfied
Accuracy	3	9/9	6/9	Fully satisfied	Satisfied
Decision Precision	5	10/15	5/15	Satisfied	Weakly satisfied
Response time	3	9/9	9/9	Fully satisfied	Fully satisfied
Privacy	2	6/6	6/6	Fully satisfied	Fully satisfied
Deployment	1	1/3	1/3	Weakly satisfied	Weakly satisfied
Total score	-	43/54	31/54	-	-

Table 11 shows the results, this time weighted according to our scoring system for both approaches, after combining the results of slow rhythm (SR) tests and quick rhythm (QR) tests of each approach. It presents the big picture of the performance of RHMNS from the evaluation and testing process.

Overall, both systems performed almost equally under identical conditions and during a full month of testing. As shown in the above tables, the activation-based approach performed better than the time-based approach. Parts of the experiment took place in the morning and in early afternoon, which are busy times with people and a number of active electronic devices and networks around; as a result, the scores of systems were varied. The high scores for response time for both approaches are reasonable because they are basically beacon-based, which accelerates the sending of current locations. Other obtained values are acceptable but surprising as well; this is going to be explained in next section.

Table 12 shows the best and worst performance results of RHMNS during the experiment. There are two scores in almost each cell. The numbers in percent represent the observed performance results of the experiment, while the other numbers represent the weighted interpretation in our scoring system.

Table 12 RHMNS best and worst performance results – scores (and values)

Criteria	Best case		Worst case	
	Activation-based	Time-based	Activation-based	Time-based
Robustness	12 (100%)	12 (100%)	0 (80%)	0 (80%)
Accuracy	9 (99%)	9 (99%)	0 (78%)	0 (60%)
Decision Precision	15 (96%)	15 (96%)	0 (75%)	0 (77%)
Response time	9 (4 s)	9 (4 s)	6 (7 s)	0 (12 s)
Privacy	6	6	6	6
Deployment	1	1	1	1
Total score	52/54	52/54	13/54	7/54

The boxplot in Figure 22 shows the variation between maximum values and minimum value of the dataset, and median value results, while the box (interquartile range) itself shows where 95% (confidence interval) of the results lie.

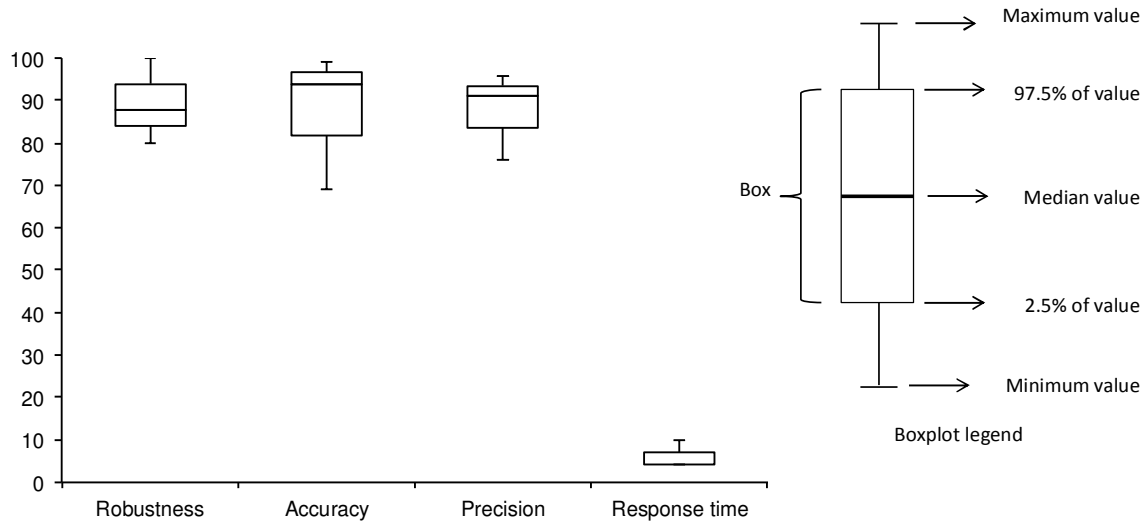

Figure 22 Boxplot diagram of the maximum, minimum and median performance results of RHMNS during the experiment, with boxes representing the 95% confidence intervals (Response time in seconds, the others in %).

5.6 Challenges

There were many challenges faced when conducting the experiment, including the following:

- 1- The validation process could not take place at TOH because the given room was no longer available to us. Therefore, although RHMNS worked properly in our lab at the University of Ottawa, it is not guaranteed to work properly at TOH as well.
- 2- The Ekahau RTLS equipment and software were at the end of their useful life and needed to be updated, which affected the performance of RHMNS as some of the hardware stop working suddenly and the software did not respond properly at times.
- 3- The delay in reporting current locations through badges, via the WiFi network, was disturbing and unacceptable. Subsequently, infrared beacons were installed in each zone to cover the weakness of WiFi-based location detection and to provide location information in a faster and more reliable way.

5.7 Discussion

There are many interesting observations made while validating RHMNS. The most remarkable ones are listed below:

- 1- When RHMNS rebooted and everything started over, it took around 13 seconds to generate and receive the first event.
- 2- The tested scenarios included just 2 nurses because the infrared beacon monitoring the hand sanitizer zone was configured to monitor micro-zones and was installed at a specific height to get results that are as accurate as possible. Therefore, the zone was too small to have more than 2 nurses in it at once. However, a scenario involving three nurses was tested while designing the test phase, before configuring the beacon in this specific way to verify the logic, and after the configuration to prove the validity of the concept (and everything worked fine). This beacon was the only one installed right above the intelligent dispenser due to the critical role of the hand sanitizer zone in deciding HH compliance.
- 3- Out of curiosity, the time taken to report the current location wirelessly (without the use of beacons) was recorded while testing the activation-based approach, for an additional 30 test runs. The average time taken to update the current location was around 20 seconds, which is absolutely unacceptable in such healthcare context.
- 4- If a badge was moved to a place that is not included in the map, the location of the badge is reported based on the zone in the map closest to the current location. For example, it was identifying that the badge was in the corridor or at the entrance of room 1, while the badge was in the other side of the lab that was not included in the map.
- 5- It rarely happened that the system detected one of the badges that entered a zone, but could not detect the other badges that entered the same zone at the same time.
- 6- RHMNS is not sensitive enough when generating events for two consecutive entrances in one zone. The system could detect either the first entrance or the second one, unless the time between the two events was around one minute.

- 7- Sometimes, RHMNS misses catching events, especially exit hand sanitizer events. The time-based approach is the most negatively affected one as this delay may yield to wrong decisions.
- 8- While designing the test phase, two buzzer commands took around 13 seconds to reach their target badges. This happened due to the low battery level of the badges. When the battery level is low, the badges cannot send any information or receive any command.
- 9- There are two major concerns with the time-based approach. The first one is spending less than 15 seconds in a hand sanitizer zone in case an HCP dispensed ABHR and moved out of the zone while rubbing it in their hands; the system will consider a missed HH opportunity because the time spent in the zone less than 15 seconds. The second concern is that if an HCP entered a hand sanitizing area and spent 30 seconds without washing hands, RHMNS would consider this a taken HH action. Due to the current limitations of the current validation and experiments, these concerns need to be further tested by conducting an experiment involving real users in a real healthcare environment.
- 10- There are some cases where RHMNS will be unable to identify taken or missed HH opportunities by an HCP such as when the HCP's badge does not face beacons because it is flipped on the other side or when the HCP enters the zone walking backward.

5.8 Chapter Summary

This chapter presented the experiment conducted in a simulated patient room at the University of Ottawa. Time-based and activation-based approaches have been validated for over a month with identical testing processes. The performance of both approaches was deemed appropriate by the hospital stakeholders. In terms of robustness, the activation-based approach performed better than the time-based approach; however, this was not a significant difference in general. In the next chapter, how RHMNS improves on competing systems, RHMNS limitations, and how RHMNS can be enhanced and expanded will be discussed.

Chapter 6. Discussion

This chapter discusses the commonalities and differences between RHMNS and other related systems through comparisons of system architectures and features. Then, it provides some important recommendations on the deployment of RHMNS in practice. Finally, it assesses the validity of this work against typical threats.

6.1 Comparison

In this section, RHMNS is compared to the related systems explained in Chapter 3 in terms of system architectures and features.

6.1.1 Architecture

Table 13 summarizes the architecture of each system. Overall, most systems have badges carried by HCPs that send information wirelessly to servers. They are similar at a conceptual level with our RTLS-based system. The main difference between RHMNS and these systems is in the way dispensers report their activation. RHMNS improves upon related systems by including an intelligent dispenser system that sends activation messages wirelessly and directly to the server, while the dispensers in other systems send IR signals received by HCPs badges (which forward the received information to servers). As explained in Chapter 4, transmitting IR signals from dispensers to badges would be an issue if badges did not receive the signals for any reason. As a result, taken HH action will not be counted. In RHMNS, if badges, for example, run out of battery, the intelligent dispenser system will still send activation messages to the server, which helps to attain an estimated result of HH compliance.

On the other hand, there are some innovative systems designed for a specific purpose, such as understanding non-compliant behaviour (Boudjema et al., 2013), or designed with unique means, such as the use of chemical indicators (Edmond et al.,

2010). However, these systems lack many features, compared to RHMNS, as will be explained in the next sub-section.

Table 13 General comparison between RHMNS and related systems in terms of system architecture

Approach	Technology
Boyce et al. (2009)	Embedded sensors into dispensers to count the number of usages
Kinsella et al. (2007)	Embedded sensors into dispensers to count the number of usages
Swoboda et al. (2004)	Embedded sensors into dispensers and sinks + motion-detectors in doorways
Venkatesh et al. (2007)	Embedded sensors into dispensers and sinks + motion-detectors in doorways
Polgreen et al. (2010)	WiFi-based communicating devices: room beacon + integrated beacons into dispensers + HCP badges
Cheng et al. (2011)	WiFi-based communicating devices: bed beacon + integrated beacons into dispensers + HCP badges
Snodgrass (2013)	WiFi-based communicating devices: bed beacon + integrated beacons into dispensers + HCP badges
Levchenko et al. (2012)	IR emitters to monitor zones+ wearable dispensers + wearable electronic monitoring device
Armellion et al. (2012)	Motion-detectors in doorways + video cameras in sinks and dispensers zone + human third-party
Fisher et al. (2013)	Ultrasound transmitters over bed and embedded into dispensers + wireless HCP badges
Boudjema et al. (2013)	RFID-based antennas located in doorways + under dispensers + around bed + embedded into HCPs' shoes
Edmond et al. (2010)	Motion-detectors in doorways + chemical sensing HCP badges
Baslyman et al. (2014)	Intelligent dispenser communicating wirelessly with the server + RTLS-based system with HCP badges

6.1.2 Features

Table 14 presents a general comparison between RHMNS and competing systems in terms of features (this table extends Table 1 with one more row at the bottom):

Table 14 Comparison between RHMNS and competing systems in terms of features

Approach	Monitor HH opportunity	Record HH taken actions	Identify HCP individually	Remind HCP of missed HH	Validation
Boyce et al. (2009)	None	Yes	No	No	Yes
Kinsella et al. (2007)	None	Yes	No	No	Yes
Swoboda et al. (2004)	Enter/exit room	Yes	No	Yes	Yes
Venkatesh et al. (2007)	Enter/exit room	Yes	No	Yes	Yes
Polgreen et al. (2010)	Enter/exit room	Yes	Yes	No	Yes
Cheng et al. (2011)	Before/after contact patient	Yes	Yes	No	Yes
Snodgrass (2013)	Before/after contact patient	Yes	Yes	Yes	N/A
Levchenko et al. (2012)	N/A	Yes	Yes	Yes	Yes
Armellion et al. (2012)	Enter/exit room	Yes	No	Yes	Yes
Fisher et al. (2013)	Before/after contact patient	Yes	Yes	Yes	Yes
Boudjema et al. (2013)	Enter/exit room + Before/after contact patient	Yes	Yes	No	Yes
Edmond et al. (2010)	Enter/exit room	Yes	Yes	Yes	Yes
Baslyman et al. (2014)	Enter/exit room + Before/after contact patient	Yes	Yes	Yes	Yes

In this table, the systems in **bold** are the competitors closest to RHMNS. The others, for example Kinsella et al. (2007) or Cheng et al. (2011), are lacking core features such as the ability to identify HCPs individually or to remind HCPs of missed HH opportunities.

According to the four moments of HH explained in Chapter 2, the only two systems that track these moments are RHMNS and Boudjema et al. (2013). However, the latter does not have the notification feature. On the other hand, there are four systems that share all features with RHMNS (Snodgrass, 2013; Fisher et al., 2013; Edmond et al., 2010; Levchenko et al., 2012). Nevertheless, Snodgrass (2013), Fisher et al. (2013) and

Edmond (2010) do not cover all four HH moments. They only identify either before/after patient contact or enter/exit a patient room opportunities. Levchenko et al. (2012) did not mention the HH moments that the system can identify.

Table 14 highlights that there are a few systems competing with RHMNS. However, RHMNS improves upon all them by identifying the four HH moments that are required by Public Health Ontario (2014) and at the same time it is capable of identifying HCPs individually, reminding them of missed HH opportunities individually and recording taken HH actions. In addition, RHMNS considers the case where more than one nurse is present in one sanitizing zone at the same time, while none of above-mentioned systems did.

6.2 Recommendations

This section presents some recommendations directed to any hospital or healthcare organization interested in adopting RHMNS or using an RTLS to monitor HH compliance.

6.2.1 Proposed Requirements Types

There are several types of requirements that are highly recommended for inclusion in the system requirements list in the future. These requirements concern essential non-functional criteria to consider before deploying any RTLS system;

- **Response time:** different stakeholder categories require different response times for different types of events and situations. Thresholds and targets needs to be determined and turned into requirements.
- **Integration:** requirements need to be identified on the necessary integration with directories (e.g., to identify HCPs or badges), reporting systems, and various healthcare information systems.
- **Compatibility:** the system shall be compatible with current WiFi infrastructure at the hospital/organization, otherwise this could make the entire project fail.
- **Wireless quality:** WiFi coverage quality is also an issue as infrared beacons cannot be installed everywhere, so appropriate requirements need again to be identified.

6.2.2 RHMNS Adoption

In order to adopt RHMNS, there are a few important points to consider:

- 1- **Cost:** it is important to calculate the total cost of adopting RHMNS before taking the decision. In addition to acquisition, deployment and maintenance costs, the cost should be estimated considering the approach selected:
 - **Activation-based approach:** if a hospital wants to adopt this approach, the cost of manufacturing and programming the intelligent dispenser system should be calculated. It might be quite expensive to equip all hand sanitizing areas with intelligent dispensers. One solution would be to prioritize and provide the care units where practicing HH is critical and where not performing HH may cause death (such as cancer centers) with the intelligent dispenser systems. Then, after evaluating the usefulness of the intelligent dispensers, the hospital could decide whether to adopt this approach in other units or not. In any case, a hospital can still use the first prototype (with an Ekahau tag) to attain what could be good-enough quality, likely at a cheaper cost. However, the issue in the latter case is to keep the tag clean all the time; otherwise, microorganisms and bacteria may transfer from hand to hand while practicing HH.
 - **Time-based approach:** it is crucial in this approach to monitor any hand sanitizing area using a beacon, while in the other approach it is preferable to use beacons but not crucial. So considering the cost of installing and maintaining extra beacons is required.
- 2- **User experience:** it is highly advised to evaluate real user experience before adopting RHMNS, likely through a pilot study. The system can then be customized based on the real users' opinions and will be beneficial at all levels.
- 3- **Specifications:** it is recommended to choose the vendor of RTLS very wisely and to ensure the availability of some specific features, for example, that badges can receive audible alert or text messages, or that tags should update current location each 3 seconds, and to ensure their support and availability to help when needed.

6.3 Threats to Validity

As validity is the extent to which observations and conclusions are well-formed and correspond to the real world, it is important to explore common categories of threats to validity, as suggested by Perry et al. (2000).

6.3.1 Construct Validity

Construct validity aims to assess the extent to which the tests actually measure what our hypothesis/system claims to be doing. An important threat here is that the four scenarios used to test the system may not be representative of real (frequent/important) situations in hospitals. Our scenarios were designed to offer a good coverage of theoretical situations, but our validation would benefit from unplanned or unexpected scenarios and situations involving real nurses and doctors doing their daily work. A related issue is that our scoring system (section 5.2.2) could be seen as arbitrary, as we do not have precise target values for the six criteria used during the evaluation. Such values can eventually be provided by using our system as a prototype or pilot system. Another threat is that we have ignored issues related to power management of tags and badges, and more importantly of intelligent dispensers. The frequent location updates required by our system and the additional power needed by dispensers to send events over the WiFi network may drain so much power that this approach could make the RTLS unusable (because batteries would require being recharged too frequently) or make the automatic dispensers unusable (because batteries would required to be changed too often). These aspects require further research and testing.

6.3.2 Internal Validity

Internal validity estimates the degree to which conclusions about causal relationships can be made based on the test settings and measures obtained. One obvious threat here is that bias might have been introduced by having the thesis author perform the tests, collect the raw data, and analyze the results. A similar issue pertains to the literature review, mainly done by one person. This was mitigated to some extent by having her supervisor involved in reviewing this work and by the participation of another student in performing the experiments (e.g., acting as the nurse who walks around). However, having a more

systematic and multi-author literature review and removing the author from the validation experiments would help minimizing potential bias. Another threat is that statistical significance was not sought for the experiments (because of limited resources), and there was no formal assessment of whether the variables used in the experiments are independent or not. Regarding the equipment, one threat here is that the Ekahau system we used was over 2 years old, with dying badges, and this introduced another level of bias. A new generation of Ekahau products is available and having access to fresher devices would help make a more precise assessment of our approach against the type of equipment that hospitals would deploy nowadays.

6.3.3 External Validity

External validity is concerned with whether results of the experiment can be generalized to other cases or contexts. Again, there are many threats here, the most important one being that the experiment data was mainly obtained in a laboratory, and not in a real hospital. This was somewhat mitigated by a pre-experiment demonstration done in a real hospital, but with a private WiFi network and without having the scenarios tested systematically multiple times. More experiment is required on that side. In addition, even if this would work in a room of the collaborating hospital, this would not mean that the system could work as well in other units or other hospitals, and hence a better sample of real contexts is required. Another threat is that our RHMNS implementation uses a specific RTLS technology (Ekahau's), and results could be worse or better with other location tracking vendors and technologies. Again, more testing is required along that dimension to claim more general results.

6.4 Chapter Summary

This chapter presented a comparison between RHMNS and close competitive systems in terms of their architecture and features. Then, it proposed some recommendations with regard to the system requirements and the system adoption. Lastly, it discussed threats to validity in our work. We are now in a position to provide conclusions and future work items, which are the topics of the next section.

Chapter 7. Conclusions and Future Work

This chapter recalls the thesis' research question, but this time with an answer and a summary of the thesis contributions. It also sheds light on future work items based on limitations and threats discussed in Chapters 5 and 6.

7.1 Answer to Research Question

“Is it feasible to have an RTLS-based system that is reliable, accurate, valid and adoptable, that does not threaten HCP privacy in the context of monitoring HH practice in hospitals, and that reminds HCPs of taking HH actions when required?”

The answer is yes. The system developed in this thesis is capable of monitoring the four required HH moments and of reminding HCPs of missed ones by sending audible alerts, buzzers, and LED color change to their badges. Also, it is able to record each taken or missed HH opportunity for HCPs, individually. In case there are more than one HCP simultaneously present at a given hand sanitizing zone, the system estimates how many of them have washed their hands and sends reminders if needed. As shown in Chapter 5, the performance of RHMNS during the experimental validation process showed the system was reliable, robust and accurate. In terms of adoptability, it is possible to adopt RHMNS provided that proper consideration is given to the effort, time and money required to acquire, install, configure, use, and maintain/optimize it. RHMNS protects HCP privacy as it does not track them out of patient rooms or corridors and it does not identify or record HCPs' real information. A crucial point to mention is that although the lab experiment results suggest that the answer is yes, the system may behave differently in a real healthcare environment due to the nature of this workplace.

7.2 Contributions

This thesis contributes to the field of automated hand hygiene monitoring and compliance in healthcare in the following ways:

- 1- It introduces the concept of *intelligent dispenser* that communicates wirelessly with servers, and validated a proof-of-concept product.
- 2- It integrates the intelligent dispenser with an RTLS-based system, a reporting system, and a custom-made real-time information correlation system to form a *RTLS-based Hand Hygiene Monitoring and Notification System (RHMNS)*.
- 3- It provides a system (RHMNS) that monitors the movements of healthcare providers inside patient rooms and corridors to identify four relevant hand hygiene moments and that records whether appropriate actions were taken or whether opportunities were missed.
- 4- It provides a system (RHMNS) that reminds healthcare providers of washing their hands, in a timely way, only when a hand hygiene opportunity is identified as missed.

7.3 Future Work

Among the future work opportunities mentioned in the thesis or implied by section 6.3 on threats to validity, here are some specific points that we would like to test or extend in the future:

- 1- Test the system with the new generation of Ekahau RTLS equipment, as this company claims that this new generation is faster and more accurate in terms of specifying location. Also, during the night in a hospital, sending audible alerts to HCPs to remind them of washing their hands is not acceptable, as most patients will be sleeping. The alternative is to send buzzers with text messages, which was not available until now.
- 2- Conduct a user experience study at the hospital to test the system in a real environment with real users.
- 3- Conduct similar experiments across different units or hospitals, to generalize the results.

- 4- Work on minimizing the cost of producing the intelligent dispenser and tackle the issue of the amount of power needed to operate the device.
- 5- Integrate RHMNS to the hospital information systems and compliance auditing system.
- 6- Enhance the report generation feature to cover more interesting metrics, trends and representations, and to be compatible with report formats required by governments and hospitals.

References

Aeroscout: *AeroScout Adds Hand Hygiene Compliance Monitoring to Its Patient & Staff Safety Solutions for Healthcare Organizations*. Press release; February 16, 2011. Available at <http://bit.ly/QBe424>

Ali M.A., Nachumow J.P., Srigley J.A., Mann S., Furness C.D. and Gardam M.: Measuring the Effect of Sousveillance in Increasing Socially Desirable Behaviour. In: *2013 IEEE Int. Symp. on Technology and Society (ISTAS)*, IEEE CS, 2013, 266–267.

Amyot D. and Mussbacher G.: User Requirements Notation: The First Ten Years, The Next Ten Years. *Journal of Software (JSW)*, Vol. 6, No. 5, Academy Publisher, May 2011, 747–768.

Armellino D., Hussain E., Schilling M.E., Senicola W., Eichorn A., Dlugacz Y. and Farber B.F.: Using High-Technology to Enforce Low-Technology Safety Measures: The Use of Third-party Remote Video Auditing and Real-time Feedback in Healthcare. *Clinical Infectious Diseases* 54(1), 2012, 547. DOI:10.1093/cid/cir773.

Baslyman M., Rezaee R., Amyot D., Mouttham A., Chreyh R., and Geiger G.: Towards an RTLS-based Hand Hygiene Notification System. In: *4th Int. Conference on Current and Future Trends of Information and Communication Technologies in Healthcare (ICTH-2014)*, Procedia Computer Science, Elsevier, September 2014, Vol. 37, 2014, 261–265.

Beresford L.: Applied Psychology Improves Hand Hygiene in Hospitals. *The Hospitalist*, Wiley, September 2013.

Boscart V.M., McGilton K.S., Levchenko A. and Hufton G., Holliday P., Fernie G.R.: Acceptability of a wearable hand hygiene device with monitoring capabilities. *Journal of Hospital Infection* 70(3), Elsevier, 2008, 216–222.

Boudjema S., Dufour J.C., Aladro A.S., Desquerres I. and Brouqui P.: MediHandTrace®: a tool for measuring and understanding hand hygiene adherence. *Clin Microbiol Infect* 20(1), 2014, 22–28.

Boulos M. and Berry G.: Real-time locating systems (RTLS) in healthcare: a condensed primer. *International Journal of Health Geographics*, June 2012, 11–25.

Boyce J.M.: Hand hygiene compliance monitoring: current perspectives from the USA. *J. Hospital Infection* 70 suppl 1, 2008, 2–7.

Boyce J.M., Cooper T. and Dolan M.J.: Evaluation of an electronic device for real-time measurement of alcohol-based hand rub use. *Infection Control and Hospital Epidemiology*, 30(11), 2009, 1090–1095. DOI:10.1086/644756.

Brereton P., Kitchenham B.A., Budgen D., Turner M., and Khalil M.: Lessons from applying the systematic literature review process within the software engineering domain. *Journal of Systems and Software* 80(4), 2007, 571–583.

Cheng V.C.C., Tai J.W.M., Ho S.K.Y., Chan J.F.W., Hung K.N., Ho P.L. and Yuen K.Y.: Introduction of an electronic monitoring system for monitoring compliance with Moments 1 and 4 of the WHO “My 5 Moments for Hand Hygiene” Methodology. *BMC Infectious Diseases*, 2011, 11:151. <http://www.biomedcentral.com/1471-2334/11/151>

Edmond M.B., Goodell A., Zuelzer W., Sanogo K., Elam K. and Bearman G.: Successful use of alcohol sensor technology to monitor and report hand hygiene compliance. *Journal of Hospital Infection* 76(4), Elsevier, 2010, 364–365.

Ekahau Inc.: *The Ekahau Real-Time Location System*. 2014. Available online at <http://bit.ly/RC55yc>

Ekahau, Professional Services: “Ekahau RTLS Requirements and Design Guide”. Requirements and Design Considerations for Deployment of Ekahau RTLS (2010)

Fisher D.A., Seetoh T., Oh May-Lin H., Viswanathan S., Toh Y., Yin W.C., Siw Eng L., Yang T.S., Schiefen S., Je M., Feng Peh R., Wei Ling Loke F. and Dempsey M.: Automated Measures of Hand Hygiene Compliance among Healthcare Workers Using Ultrasound: Validation and a Randomized Controlled Trial. *Infect Control Hosp Epidemiol* 34(9), 2013, 919–928.

Ghosh A., Lacey G., Gush C. and Barnes S.: The impact of real-time computerised video analysis and feedback on hand hygiene practice and technique on a surgical ward. In: *International Conference on Prevention & Infection Control*, Geneva, Switzerland, *BMC Proceedings*, 5(Suppl 6):O52, 2011.

Gould D.J., Drey N.S. and Creedon S.: Routine hand hygiene audit by direct observation: has nemesis arrived? *Journal of Hospital Infection* 77(4), Elsevier, 2011, 290–293.

Grayson M.L., Jarvie L.J., Martin R., et al. Significant reductions in methicillin-resistant *Staphylococcus aureus* bacteraemia and clinical isolates associated with a multisite, hand hygiene culture-change program and subsequent successful statewide roll-out. *Med J Aust* 188(11), 2008, 633–640.

Grol R. and Grimshaw J.: From best evidence to best practice: effective implementation of change in patients’ care. *Lancet* 362(9391), October 2003, 1225–30.

Haas J.P. and Larson E.L.: Measurement of compliance with hand hygiene. *Journal of Hospital Infection* 66(1), Elsevier, 2007, 6–14.

Hevner A.R., March S.T., Park J. and Ram S.: Design Science in Information Systems Research. *MIS Quarterly*, Vol. 28, No. 1, March 2004, pp 75-105.

Higgins A. and Hannan M.M.: Improved hand hygiene technique and compliance in healthcare workers using gaming technology. *Journal of Hospital Infection* 84(1), Elsevier, 2013, 32–37.

Khan K., Kunz R., Kleijnen J., Antes G.: *Five steps to conducting a systematic review*. *Journal of the royal society of medicine*, 2003, 96:118-121.

Kinsella G., Thomas A.N., and Taylor R.J.: Electronic surveillance of wall-mounted soap and alcohol gel dispensers in an intensive care unit. *Journal of Hospital Infection* 66(1), Elsevier, 2007, 66, 34–39.

Levchenko A., Boscart V.M. and Fernie G.R.: The feasibility of an automated monitoring system to improve nurses' hand hygiene. *International journal of medical informatics* 80(8), 2011, 596–603.

Levchenko A., Boscart V.M. and Fernie G.R.: Hand Hygiene Monitoring and Real-Time Prompting System. In: *2012 IEEE Systems Conference*, IEEE CS, 2012,1–5.

Levchenko A., Boscart V.M. and Fernie G.R.: The Effect of Automated Monitoring and Real-Time Prompting on Nurses' Hand Hygiene Performance. *Computers, Informatics, Nursing (CIN)* 31(10), October 2013, 498–504.

Magiorakos A.P., Leens E., Drouvot V., May-Michelangeli L., Reichardt C., Gastmeier P., Wilson K., Tannahill M., McFarlane E. and Simon A.: Pathways to clean hands: highlights of successful hand hygiene implementation strategies in Europe. *Euro Surveill* 15(18), 2010, Art. 4. <http://www.eurosurveillance.org/ViewArticle.aspx?ArticleId=19560>

Perry D.E., Porter A.A. and Votta L.G.: Empirical studies of software engineering: a roadmap. *Conf. on the Future of Software Engineering*, ICSE'2000, ACM, 2000, 345–355.

Pessoa-Silva C.L., Hugonnet S., Pfister R., et al. Reduction of health care associated infection risk in neonates by successful hand hygiene promotion. *Pediatrics* 120(2), 2007, 382–390.

Public Health Agency of Canada. *The Chief Public Health Officer's Report on the State of Public Health in Canada, 2013: Infectious Disease—The Never-ending Threat*. September 2013. Available online at <http://publichealth.gc.ca/CPHOREport>

Public Health Ontario, Ontario Agency for Health Protection and Promotion, Provincial Infectious Diseases Advisory Committee. *Best Practices for Hand Hygiene in All Health Care Settings*. 4th ed. Toronto, ON: Queen's Printer for Ontario; April 2014.

Polgreen P.M, Hlady C.S., Severson M.A., Segre A.M. and Herman T.: Method for Automated Monitoring of Hand Hygiene Adherence without Radio-Frequency Identification. *Infect Control Hosp Epidemiol* 31(12), December 2010, 1294–1297. DOI:10.1086/657333.

Pyne E.: *Physician Attitudes toward Hand Hygiene in the Acute Care Setting*. Wisconsin Medical Society Fellowship, June-August 2010. <http://www.dhs.wisconsin.gov/communicable/HAI/Reports/HHProjectReport.pdf>

Rezaee R., Baslyman M., Amyot D., Mouttham A., Chreyh R., and Geiger G.: Location-Based Patient-Device Association and Disassociation. In: *4th Int. Conference on Current and Future Trends of Information and Communication Technologies in Healthcare (ICTH-2014)*, Procedia Computer Science, Elsevier, September 2014, Vol. 37, 2014, 282–286.

Rupp M.E., Fitzgerald T., Puumala S., et al. Prospective, controlled, cross-over trial of alcohol-based hand gel in critical care units. *Infect Control Hosp Epidemiol* 29(1), 2008, 8–15.

Sahud A., Bhanot N., Radhakrishnan A., Bajwa R., Manyam H. and Post J.: An Electronic Hand Hygiene Surveillance Device: A Pilot Study Exploring Surrogate Markers for Hand Hygiene Compliance. *Infection Control and Hospital Epidemiology* 31(6), June 2010, 634–639.

Salama M.F., Jamal W.Y., Al Mousa H.A., Al-AbdulGhani K.A. and Rotimi V.O.: The effect of hand hygiene compliance on hospital-acquired infections in an ICU setting in a Kuwaiti teaching hospital. *Journal of Hospital Infection* 6(1), Elsevier, 2013, 27–34.

Sax H., Allegranzi B., Uçkay I., Larson E., Boyce J. and Pittet D.: ‘My five moments for hand hygiene’: a user-centred design approach to understand, train, monitor and report hand hygiene. *Journal of Hospital Infection* 67(1), Elsevier, 2007, 9–21.

Scott II R.D.: *The Direct Medical Costs of Healthcare-Associated Infections in U.S. Hospitals and the Benefits of Prevention*. Centers for Disease Control and Prevention, March 2009. Available online at http://www.cdc.gov/hai/pdfs/hai/scott_costpaper.pdf

Snodgrass D. *Sanitization compliance monitoring system*. US patent 8,674,840. Ultra-Clenz, LLC, 2013.

Squires J.E., Suh K.N., Linklater S., Bruce N., Gartke K., Graham I.D., Karovitch A., Read J., Roth V., Stockton K., Tibbo E., Woodhall k., Worthington J. and Grimshaw J.M.: Improving physician hand hygiene compliance using behavioural theories: a study protocol. *Implementation Science*, February 2013, 8–16.

Suresh G. and Cahill J.: National Patient Safety Goals. How ‘User Friendly’ is the Hospital for Practicing Hand Hygiene?: An Ergonomic Evaluation. *The Joint Commission Journal on Quality and Patient Safety* 33.3, 2007.

Swoboda S.M., Earsing K., Strauss K., Lane S., and Lipsett P.A.: Electronic monitoring and voice prompts improve hand hygiene and decrease nosocomial infections in an intermediate care unit. *Crit Care Med* 32(2), 2004, 358–364.

Tchemeube R.B.: Location-Aware Business Process Management for Real-time Monitoring of Patient Care Processes. M.C.S. thesis, Computer Science, University of Ottawa, Canada, 2013

Tchemeube R.B., Amyot D., Mouttham A. Location-Aware Business Process Management for Real-time Monitoring of a Cardiac Care Process. In: *23rd Int. Conf. Center for Advanced Studies on Collaborative Research (CASCON'13)*, IBM/ACM, November 2013, 230–244.

Thi Anh Thu L., Dibley M.J., Nho V.V., Archibald L, Jarvis W.R., Sohn A.H. Reduction in surgical site infections in neurosurgical patients associated with a bedside hand hygiene program in Vietnam. *Infect Control Hosp Epidemiol* 28(5), 2007, 583–588.

Venkatesh A.K., Lankford M.G., Rooney D.M, Blachford T., Watts C.M., and Noskin G.A.: Use of electronic alerts to enhance hand hygiene compliance and decrease transmission of vancomycin-resistant *Enterococcus* in a hematology unit. *Am J Infect Control* 36(3), 2008, 199–205.

Appendix A: Literature Review Queries

The composite queries used in the literature review are as follows:

- ("hand washing" OR "hand hygiene") AND
("problem" OR "challenge" OR "issues") AND
healthcare AND compliance
- ("hand washing" OR "hand hygiene") AND compliance AND healthcare
- ("hand washing" OR "hand hygiene") AND
compliance AND Canada AND healthcare
- ("hand washing" OR "hand Hygiene") AND
("monitor" OR "measure") AND
compliance AND healthcare
- ("hand washing" OR "hand hygiene") AND
("automated monitoring" OR "automated system" OR "RFID") AND
healthcare
- ("hand washing" OR "hand hygiene") AND
("RTLS" OR "systems") AND
healthcare
- ("hand washing" OR "hand hygiene") AND
("strategy" OR "method") AND
healthcare AND compliance AND improvement

Appendix B: Sample Hand Hygiene Compliance Reports

A sample of a hand hygiene (HH) compliance report generated by EazyBI with a connection to the RHMNS database is shown in Figure 23.

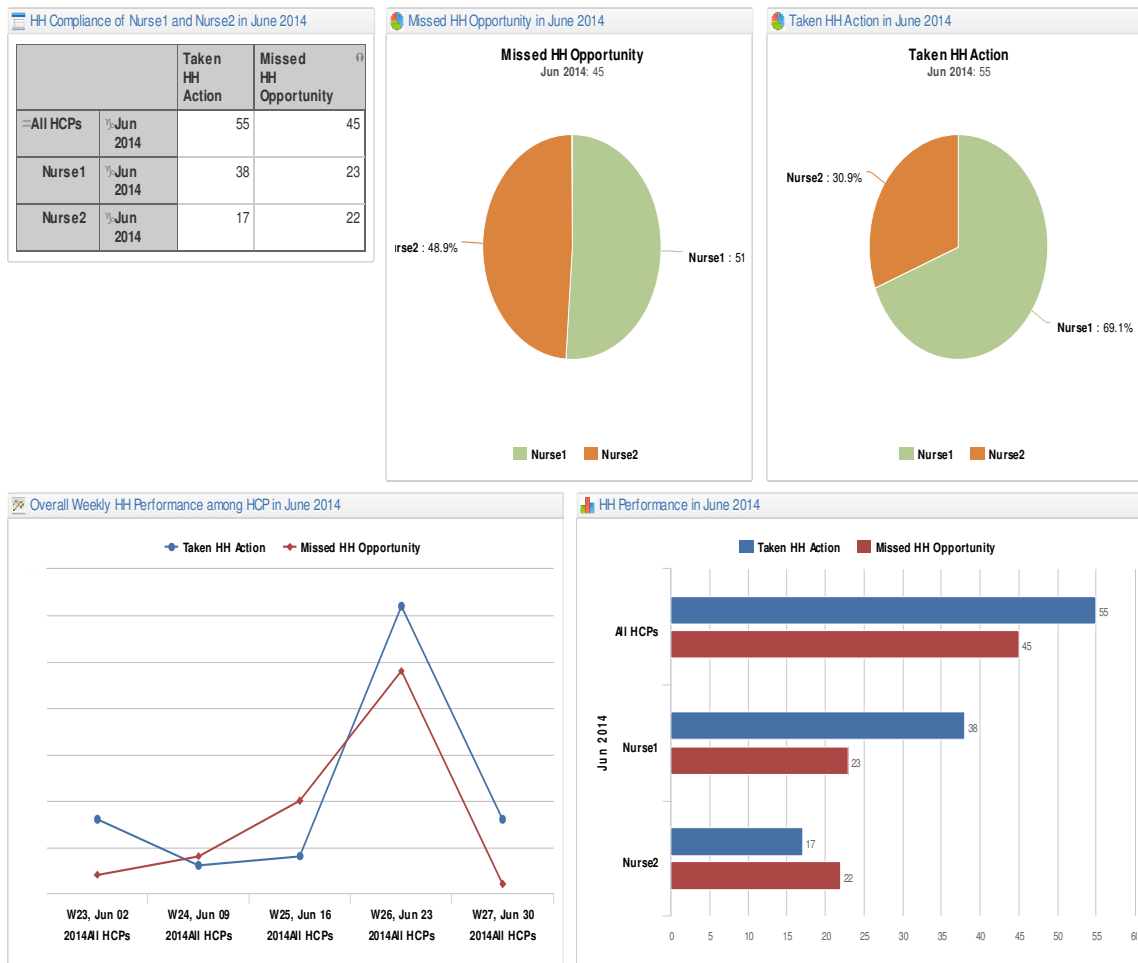

Figure 23 Sample hand hygiene report generated with EazyBI

The table in the report shows how many times Nurse1 and Nurse2 (together and individually) took HH actions, out of 61 HH opportunities for Nurse 1 and 39 HH opportunities for Nurse 2 (in total 100 HH opportunities for both nurses in June 2014).

The pie charts demonstrate the same information presented in the table but in percentage representation. The line chart presents trends of taken and missed HH opportunities weekly, by all HCPs over June 2013. The bar chart highlights the same information described in the table.

The following two report samples (Figure 24) show that the numbers can also be represented with ratios in order at times to be more meaningful than pure numbers (as in the pie charts of Figure 23).

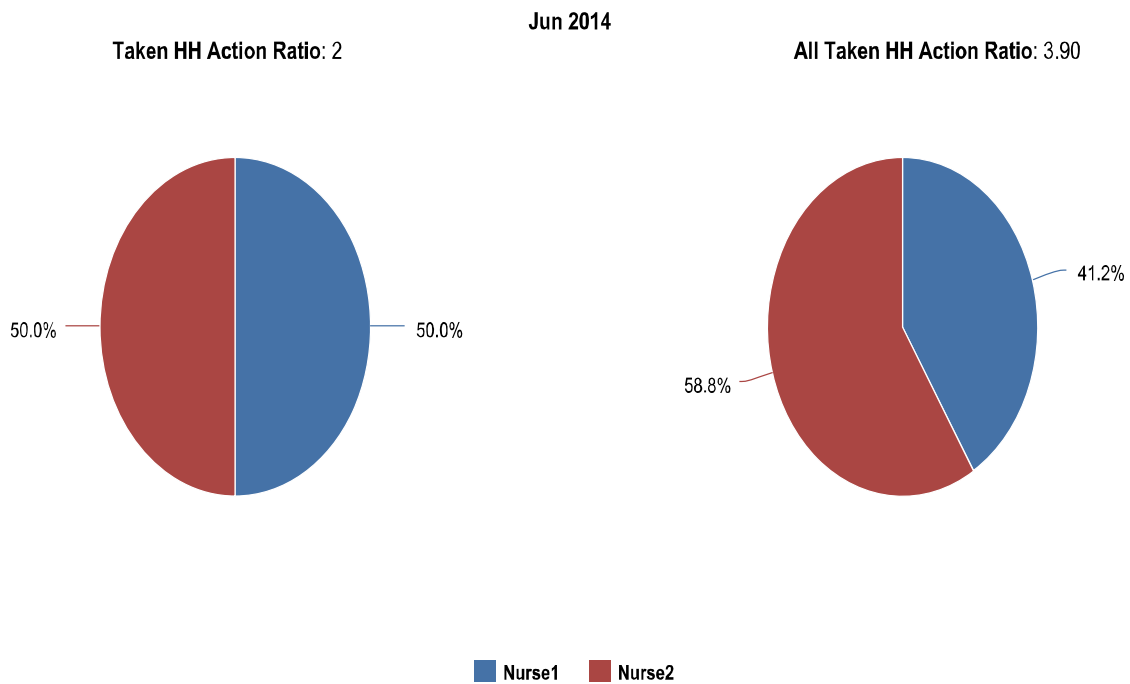

Figure 24 Sample reports on nurses, with ratios

As seen in the right pie chart of Figure 24, Nurse 2 has taken more HH action than Nurse 1. However, this does not mean that Nurse 1 is missing more HH opportunities than Nurse 2. In the same figure, the left pie chart shows the total number of taken HH opportunities by each nurse individually compared to all HH opportunities identified by RHMNS, which shows that both nurses practiced HH almost equally when it was required to do so.

The following bar chart (Figure 25) shows the ratio of all HH opportunities (missed or taken) by each nurse, individually.



Figure 25 Sample report comparing two nurses with bar charts

Appendix C: Experiment Sheet

Date: **Time:** **Round:** **Scenario no.:**

1- Robustness:

Crash down:

Not respond:

2- Accuracy of detection positions

No. of entered zones:

No. of correctly detected

No. of wrongly detected

3- Decision precision

No. of required buzzers:

Washed-No-buzzer

Not-washed-buzzer

Not-washed-no-Buzzer

Washed-buzzer

4- Response time

Enter zone

Exit zone

dispenser

send buzz

receive buzz

5- Comments