



National Library
of Canada

Bibliothèque nationale
du Canada

Canadian Theses Service

Service des thèses canadiennes

Ottawa, Canada
K1A 0N4

NOTICE

The quality of this microform is heavily dependent upon the quality of the original thesis submitted for microfilming. Every effort has been made to ensure the highest quality of reproduction possible.

If pages are missing, contact the university which granted the degree.

Some pages may have indistinct print especially if the original pages were typed with a poor typewriter ribbon or if the university sent us an inferior photocopy.

Reproduction in full or in part of this microform is governed by the Canadian Copyright Act, R.S.C. 1970, c. C-30, and subsequent amendments.

AVIS

La qualité de cette microforme dépend grandement de la qualité de la thèse soumise au microfilmage. Nous avons tout fait pour assurer une qualité supérieure de reproduction.

S'il manque des pages, veuillez communiquer avec l'université qui a conféré le grade.

La qualité d'impression de certaines pages peut laisser à désirer, surtout si les pages originales ont été dactylographiées à l'aide d'un ruban usé ou si l'université nous a fait parvenir une photocopie de qualité inférieure.

La reproduction, même partielle, de cette microforme est soumise à la Loi canadienne sur le droit d'auteur, SRC 1970, c. C-30, et ses amendements subséquents.

Extracellular β -D-Mannanase Activity
from *Trichoderma harzianum* E58

Joan P. Torrie

Thesis submitted to
the School of Graduate Studies and Research
in partial fulfillment of the requirements for the degree of
Doctor of Philosophy in Biology

University of Ottawa



National Library
of Canada

Bibliothèque nationale
du Canada

Canadian Theses Service Service des thèses canadiennes

Ottawa, Canada
K1A 0N4

The author has granted an irrevocable non-exclusive licence allowing the National Library of Canada to reproduce, loan, distribute or sell copies of his/her thesis by any means and in any form or format, making this thesis available to interested persons.

The author retains ownership of the copyright in his/her thesis. Neither the thesis nor substantial extracts from it may be printed or otherwise reproduced without his/her permission.

L'auteur a accordé une licence irrévocable et non exclusive permettant à la Bibliothèque nationale du Canada de reproduire, prêter, distribuer ou vendre des copies de sa thèse de quelque manière et sous quelque forme que ce soit pour mettre des exemplaires de cette thèse à la disposition des personnes intéressées.

L'auteur conserve la propriété du droit d'auteur qui protège sa thèse. Ni la thèse ni des extraits substantiels de celle-ci ne doivent être imprimés ou autrement reproduits sans son autorisation.

ISBN 0-315-75032-4

Canada



UNIVERSITÉ D'OTTAWA
UNIVERSITY OF OTTAWA

ABSTRACT

Until recently, very little data was available regarding the production and substrate specificity of the individual fungal enzymes involved in the degradation of heteropolymeric β -D-mannans. It was not until the potential application of 'cellulase-free' β -D-mannanases (EC 3.2.1.78) in the processing of chemical pulps was considered that, interest in physicochemical characteristics of β -D-mannanases increased. Extracellular β -D-mannanases of yeast and filamentous fungi were of particular interest because of the ability of these organisms to excrete relative high amounts of proteins at a high rate. In this work, 4 yeasts (*Pichia wickerhammi*, *Candida wickerhammi*, *Pichia stipitis* CBS5776, *Pichia stipitis* CBS5876), and 5 fungi (*Theivalia* spp., *Thermoascus aurantiacus*, *Tyromyces palustris* A, *Aspergillus niger*, *Trichoderma harzianum*), known to excrete enzymes capable of hydrolyzing polysaccharides found in association with β -D-mannans, were assessed for their ability to degrade β -D-mannans. The β -D-mannanase activity found in the culture filtrate of *T. harzianum* was selected for further study and a 'cellulase-free' β -D-mannanase isolated from culture filtrates of *T. harzianum* grown on medium supplemented with 1% w/v locust bean gum studied.

β -D-Mannanase activity was detected in *T. harzianum* culture filtrates from media supplemented with 1 % (w/v) Avicel, locust bean gum galactomannan, konjac root glucomannan, or spruce wood water-solubles. Medium supplemented with 1 % (w/v) mannose did not induce β -D-glucomannanase or β -D-galactomannanase activity. However, when 0.5 % (w/v) β -D-galactomannan was added with mannose, β -D-mannanase activity was detected in the culture filtrate. Growth of the fungus on mannan-

rich locust bean gum resulted in the highest specific β -D-glucomannanase and β -D-galactomannanase values. A zymogram assay was developed to selectively detect β -D-mannanase activity in crude culture filtrates. The presence of different polysaccharides in the growth medium resulted in different β -D-mannanase zymogram profiles. Analyses of the protein profiles of the culture filtrates separated by isoelectric focusing revealed several bands having β -D-mannanase and endoglucanase activity.

A protein band having β -D-mannanase activity but lacking detectable cellulase activity was identified. This enzyme was purified to homogeneity via a sequence involving ultrafiltration, ion exchange and gel filtration. This 'cellulase-free' β -D-mannanase has the highest reported pI for a fungal β -D-mannanase. The isolated enzyme had a molecular weight of 42.9 ± 4 kD, an optimum temperature of 60 - 65 °C, an optimum pH of 5.8, a pI of 6.55, and possessed at least 75% of maximum activity over a pH range from 3.21 - 6.8. Enzymatic activity was stable during 12 months of storage at 4 °C. β -D-mannanase activity was resistant to pepsin, α -chymotrypsin, trypsin, and *Staphylococcus* V8 protease. The effect of metal ions, detergent and solvents on β -D-mannanase activity was also determined.

Although the enzyme did not degrade Avicel or Solka floc, it did associate with both celluloses. Enzyme associated with these celluloses remained active towards locust bean gum galactomannan. The overall efficiency of the enzyme (V_{max}/K_m) for the target substrate, locust bean gum galactomannan, was reduced by the presence of 1.0% w/v Avicel. The specific activity of the enzyme towards locust bean galactomannan, guar gum, konjac glucomannan and pine glucomannan was 73.4, 27.2, 41.7 and 44.3 IU/mg protein respectively. Of the four β -D-mannans tested, the enzyme had greatest overall

efficiency towards konjac glucomannan. However, deacetylation of konjac glucomannan lowered the efficiency of the enzyme by 41.5%.

The products of enzymatic hydrolysis of the β -D-mannans were dimers, trimers and low molecular weight oligomers. Enzymatic hydrolysis of mannobiose, mannotriose and mannotetrose was not detected by TLC analysis. When carboxymethyl cellulose was treated with the enzyme, HPLC and TLC analysis did not detect hydrolysis products. The enzyme did not possess detectable α -galactosidase, β -mannosidase, or β -xylanase activity.

However, the ability of the enzyme to degrade β -D-mannans in the presence of celluloses and xylans, as well as the observed increase in reducing sugars in spruce lignin carbohydrate solutions after enzyme treatment, demonstrated the ability of the enzyme to act in the presence of other polysaccharides and wood components.

RÉSUMÉ

Jusqu'à tout récemment encore, il existait très peu de renseignements disponibles sur la production et la spécificité des substrats d'enzymes fongiques qui interviennent dans la décomposition des hétéropolymères de β -D-mannanes. Ce n'est que l'on ait envisagé d'utiliser des β -D-mannanases (EC 3.2.1.78) « libres de cellulase » pour transformer la pâte chimique, que s'est accru l'intérêt pour les caractéristiques physicochimiques des β -D-mannanases. Les β -D-mannanases extracellulaires de levures et de champignons filamenteux représentaient un intérêt particulier, car ces organismes avaient la capacité d'extraire, à des vitesses élevées, des quantités relativement élevées de protéines. Au cours de ces travaux, pour évaluer leur capacité de décomposer les β -D-mannanes, on a étudié quatre levures (*Pichia wickerhammi*, *Candida wickerhammi*, *Pichia stipitis* CBS5776, *Pichia stipitis* CBS5876) et cinq champignons (*Theivalia spp.*, *Thermoascus aurantiacus*, *Tyromyces palustris* A, *Aspergillus niger*, *Trichoderma harzianum*), connus pour extraire les enzymes capables d'hydrolyser les polysaccharides découverts en association avec les β -D-mannanes. On a choisi d'étudier plus en profondeur l'activité de la β -D-mannanase présente dans le filtrat cultivé de *T. harzianum* et d'une β -D-mannanase « libre de cellulase » isolée à partir de filtrats cultivés de *T. harzianum* qui a poussé dans un milieu alimenté de gomme de caroube à 1 % (w/v).

On a détecté une activité de la β -D-mannanase dans les filtrats cultivés de *T. harzianum* issus de milieux auxquels on a ajouté de l'Avicel (w/v) à 1 %, du galactomannane de gomme de caroube, du glucomannane de racine de konjac ou des solubles dans l'eau de sapin. Le milieu alimenté de mannose à 1 % (w/v) n'a pas provoqué une activité de la β -D-glucomannanase ou de la β -D-galactomannanase. Toutefois, lorsqu'on a ajouté au mannose 0,5 % du β -D-galactomannane (w/v), on a détecté une activité de la β -D-mannanase dans les filtrats cultivés. La croissance de

champignons sur la gomme de caroube riche en mannanes a conduit aux valeurs les plus élevées de la β -D-glucomannanase et de la β -D-galactomannanase. On a mis au point des essais à partir de diagrammes enzymatiques afin de détecter de manière ponctuelle l'activité du β -D-mannanase dans des filtrats cultivés de forme brute. La présence de différents polysaccharides dans le milieu de croissance s'est traduite par divers profils de diagrammes enzymatiques de la β -D-mannanase. L'analyse des profils protéiques des filtrats cultivés isolés par électrofocalisation a révélé diverses bandes présentant une activité de la β -D-mannanase et de l'endoglucanase.

On a identifié une bande protéique possédant une activité de la β -D-mannanase mais dont celle de la cellulase était imperceptible à détecter. On a purifié cette enzyme jusqu'à obtention d'homogénéité par la voie d'une séquence où l'on a utilisé l'ultrafiltration, l'échange d'ions et la filtration sur gel. Cette β -D-mannanase « libre de cellulase » possédait le pI le plus élevé enregistré pour ce qui est d'un β -D-mannanase de souche fongique. L'enzyme isolée possédait un poids moléculaire de 42,94 kD, une température optimale de 60 - 65 °C, un pH optimal de 5,8, un pI de 6,55, et enregistrait une activité maximale d'au moins 75 % pour un pH qui varie de 3,21 à 6,8. L'activité enzymatique s'est avérée stable pendant les 12 mois d'entreposage à 4 °C. L'activité de la β -D-mannanase offrait une résistance à la pepsine, à la α -chymotrypsine, à la trypsine et à la protéase V8 *Staphylococcus*. On a également pu mesurer l'influence des ions métalliques, des détergents et des solvants sur l'activité de la β -D-mannanase.

Bien que l'enzyme n'ait pas pu décomposer d'Avicel et de Solka floc, elle a été liée à ces celluloses. L'enzyme liée à ces celluloses est demeurée active sur le galactomannane de la gomme de caroube. L'efficacité globale de l'enzyme (V_{max}/K_m) destinée au substrat cible, le galactomannane de la gomme de caroube, a subi une réduction en raison de la présence de 1,0 % w/v Avicel. Les activités respectives de l'enzyme sur le galactomannane de la gomme de caroube, de la gomme de guar, des glucomannanes de konjac et de pin étaient de 73,4, de 27,2, de 41,7 et de 44,3 UI/mg de protéines. Parmi les quatre β -D-mannanes analysés, c'est le glucomannane de

konjac qui a produit l'efficacité globale la plus manifeste de l'enzyme. Toutefois, la déacétylation du glucomannane de konjac a réduit dans une proportion de 41,5 % l'efficacité de l'enzyme.

Les produits issus de l'hydrolyse enzymatique des β -D-mannanes étaient des dimères, des trimères et des oligomères de poids moléculaires peu élevés. L'analyse par chromatographie en couche mince (CCM) n'a pas permis de détecter l'hydrolyse enzymatique des mannobiose, mannotriose et mannotérose. Lorsqu'on a traité la carboxyméthyl cellulose avec l'enzyme, la CHPL (chromatographie à haute pression liquide), et la CCM n'ont pas permis de détecter les produits de l'hydrolyse. Il a également été impossible de détecter l'activité de la β -galactosidase, de la β -mannosidase ou de la xylanase. susceptible de présenter l'enzyme. Toutefois, la capacité de l'enzyme à décomposer les β -D-mannans en présence de celluloses et de xylanes, tout comme les plus importantes réductions observées de sucres dans les solutions d'hydrates de carbone de lignine de sapin après traitement enzymatique, ont fait la preuve de la capacité de l'enzyme à réagir en présence d'autres polysaccharides et de composantes du bois.

TABLE OF CONTENTS

ABSTRACT	i
RÉSUMÉ	iv
LIST OF TABLES	xiii
LIST OF FIGURES	xv
ACKNOWLEDGEMENTS	xix
INTRODUCTION	1
I. Research Objectives and Rationale	1
II. The Structure of Wood	6
III. The Composition and Structure of Mannans	10
A. Wood mannans	14
IV . Enzymatic Degradation of Mannans	15
A. Classification and detection of β -mannanase activity	28
1. Classification and detection of β -mannanase capable of degrading wood mannans.	31
V. The Potential Applications of β -Mannanases	33
MATERIALS AND METHODS	35
I. Reagents	35
II. Fungal Culture Conditions and Inoculum	35
III. Polysaccharide Preparation and Analysis	36
A. Substrate preparation.	36
1. Celluloses.	36

2. Xylans.	36
3. Wood and wood derivatives.	36
4. Mannans.	37
B. Analysis of polysaccharides used as media supplements.	38
IV. Analytical Methods and Experimental Techniques	39
A. Quantitative chromogenic techniques.	39
B. Enzyme assays.	40
C. Isoelectric focusing and zymogram techniques.	42
1. Isoelectric focusing (IEF).	42
2. Zymogram analysis.	43
D. Chromatographic techniques.	44
1. Thin layer chromatography (TLC) analysis.	44
2. High performance liquid chromatography (HPLC).	45
3. Ion exchange chromatography.	45
4. Gel filtration.	48
V. Experimental Procedures	49
A. Screening protocols for fungal β -D-mannanase activity.	49
1. The ability to grow in β -D-mannan supplemented medium.	49
2. The ability to utilize β -D-mannan.	50
3. The ability of culture filtrates to solubilize β -D-mannan on solid medium.	50
B. Production and identification of <i>T. harzianum</i> E58 β -D-mannan- degrading enzymes.	51

1. Production of β -D-mannanase activity by <i>Trichoderma</i> <i>harzianum</i> E58	51
2. Production of β -D-mannanase activity in the presence of mannose.	53
C. Isolation of the extracellular β -D-mannanase activity from <i>T.</i> <i>harzianum</i> E58.	53
STEP 1. Production and concentration of culture filtrate containing β -D-mannanase activity	53
STEP 2. Fractionation of the Amicon retentate by preparative anion exchange on DEAE-Sepharose.	54
STEP 3. Gel filtration of pooled β -D-mannanase from anion exchange chromatography.	55
D. Enzyme properties of the β -D-mannanase isolated from <i>T. harzianum</i> E58 culture filtrate.	55
1. Molecular weight determination.	55
2. Substrate hydrolysis.	56
3. Optimum temperature.	58
4. Thermostability.	58
5. The influence of pH on activity.	59
E. Effectors of enzyme activity.	60
1. Proteases.	60
2. Metal ions.	60
3. Detergents and solvents.	61

F. Interaction with non-target polysaccharides.	62
1. Enzyme activity in the presence of non-target substrates.	62
2. Association with celluloses and xylans.	62
3. Impact on apparent kinetic parameters.	63
G. The interaction of <i>T. harzianum</i> β -D-mannanase with other hemicellulases.	63
RESULTS	65
I. Detection and Determination of β -Mannan Degradation by Various Fungi . . .	65
II. Production of β -Mannanase Active Enzymes by <i>T. harzianum</i> E58	68
A. Production of β -mannanase activity by <i>T. harzianum</i> E58 grown on mannan-rich and non-mannan polysaccharide media.	68
B. β -D-Mannanase production in the presence of mannose.	72
III. Zymogram Detection of β -Mannanase Proteins in Culture Filtrates of <i>T. harzianum</i> E58	75
IV. Isolation and Properties of Extracellular β -Mannanase 6.55 from <i>T. harzianum</i> E58	82
A. Isolation of β -mannanase 6.55.	82
STEP 1: Ultrafiltration.	86
STEP 2: Anion exchange chromatography on DEAE-Sepharose.	86
STEP 3: Gel filtration.	89
B. Estimation of protein homogeneity and characterization.	91
C. Substrate specificity.	91
D. The kinetic parameters of <i>T. harzianum</i> E58 β -mannanase 6.55.	96

E. Substrate side-groups and enzyme activity.	101
F. The effect of temperature on enzyme activity.	103
G. The effect of pH on enzyme activity	103
H. Effectors of enzyme activity.	107
1. Proteases.	107
2. Metal ions.	109
3. Detergents and solvents.	109
I. The interaction of <i>T. harzianum</i> E58 β -D-mannanase with non-mannan polysaccharides.	111
1. Celluloses.	114
2. Xylans.	119
J. The interaction of <i>T. harzianum</i> E58 β -mannanase with other hemicellulases.	119
DISCUSSION	122
I. Detection and Determination of β -Mannan Degradation	122
A. The role of model substrates.	122
B. Detection of β -mannanase activity.	124
C. Measurement of β -mannanase activity levels.	126
II. Production of Extracellular β -Mannanase by <i>T. harzianum</i> E58.	130
III. Isolation and Properties of Extracellular β -Mannanase 6.55 from <i>T. harzianum</i> E58 Culture Filtrate.	136
A. Isolation of β -mannanase 6.55.	136
B. Molecular properties of β -mannanase 6.55.	139

C. Substrate specificity of β -mannanase 6.55.	141
D. Effectors of enzyme activity.	144
IV. The Interaction of <i>T. harzianum</i> E58 β -Mannanase 6.55 with Non-target Polysaccharides	150
V. The Interaction of <i>T. harzianum</i> E58 β -Mannanase 6.55 with Other Hemicellulases	154
Concluding Remarks	157
REFERENCES.	159

LIST OF TABLES

Table 1. The percent composition of wood.	4
Table 2. The structural diversity of mannans.	12
Table 3a. Identification of β -mannanase producing bacteria	18
Table 3b. Identification of β -mannanase producing fungi	23
Table 4. Mannan utilization by selected organisms	66
Table 5. Extracellular enzyme activities detected after growth of <i>Trichoderma harzianum</i> on various substrates.	71
Table 6. The influence of substrate composition on the relative endoglucanase and galactomannanase activities in <i>Trichoderma harzianum</i> E58 culture filtrates.	73
Table 7. Purification of the β -mannanase activity from the culture filtrate of <i>Trichoderma harzianum</i> E58 grown on 1% (w/v) locust bean gum. . .	84

Table 8. Enzyme activities measured during the isolation of β -mannanase activity found in <i>Trichoderma harzianum</i> E58 culture filtrate.	85
Table 9. Characteristics of isolated fungal β -mannanases	93
Table 10. Kinetic parameters of <i>Trichoderma harzianum</i> E58 β -mannanase 6.55	100
Table 11. Effect of protease on the activity of β -mannanase 6.55.	108
Table 12. The effect of the presence of Avicel and xylan on the kinetic parameters of β -mannanase 6.55 towards locust bean gum β -D- galactomannan	116
Table 13. The association of β -mannanase activity with celluloses.	118
Table 14. The ability of extracellular hemicellulase enzymes to release reducing sugars from black spruce lignin carbohydrate complex.	121

LIST OF FIGURES

Figure 1.	The association of cellulose, hemicellulose and lignin within wood lignocellulose	7
Figure 2.	The schematic representation of woody cell wall structure	9
Figure 3.	Partial chemical structure of O-acetyl-galactoglucomannan from softwood	16
Figure 4.	The production of β -mannanase activity and changes in the medium during growth of <i>Trichoderma harzianum</i> E58 on modified Mandels medium containing 1% (w/v) of Avicel, locust bean gum, konjac root powder β -glucomannan, or, spruce water-solubles	68
Figure 5.	Enzyme production by <i>Trichoderma harzianum</i> E58 grown on modified Mandels medium containing 1% (w/v), a) Avicel; b) Locust bean gum; c) Konjac root powder; d) Spruce water-solubles.	69

Figure 6.	The β -galactomannanase activity, protein content, and pH of culture filtrates of <i>Trichoderma harzianum</i> E58 grown on Mandels medium containing	
	a) 1% (w/v) Locust bean gum, b) 0.5% (w/v) Mannose + 0.5% (w/v) locust bean gum, c) 1% (w/v) Mannose.	74
Figure 7a.	Silver stain profiles of proteins present in culture filtrates of <i>Trichoderma harzianum</i> E58 separated by isoelectric focusing. . .	76
Figure 7b.	β -Galactomannanase zymogram profiles of proteins present in culture filtrates of <i>Trichoderma harzianum</i> E58 separated by isoelectric focusing.	77
Figure 8a.	Zymogram and protein staining of culture filtrates from <i>Trichoderma harzianum</i> E58 grown on 1.0% (w/v) Avicel medium and separated by isoelectric focusing.	80
Figure 8b.	Zymogram and protein staining of culture filtrates from <i>Trichoderma harzianum</i> E58 grown on 1.0% (w/v) locust bean gum medium and separated by isoelectric focusing	81

Figure 9.	The effect of incubation time upon locust bean gum β -D-galactomannan and konjac β -D-glucomannan hydrolysis by <i>Trichoderma harzianum</i> E58 β -mannanase 6.55.	83
Figure 10.	Anion exchange chromatography of <i>Trichoderma harzianum</i> E58 ultrafiltration retentate.	88
Figure 11.	Sephadex G-100 gel filtration chromatography of pooled β -mannanase fractions obtained from anion exchange chromatography.	90
Figure 12.	Coomassie blue stained SDS PAGE gel of protein standards kit and isolated β -mannanase 6.55.	92
Figure 13.	Thin layer chromatography analysis of β -mannanase treated materials	95
Figure 14.	The substrate specificity of pure β -mannanase.	97
Figure 15.	The effect of substrate concentration on the rate of β -D-mannan hydrolysis by <i>Trichoderma harzianum</i> β -mannanase 6.55.	99
Figure 16.	Lineweaver-Burk plot for <i>Trichoderma harzianum</i> β -mannanase 6.55 active on konjac and deacetylated konjac β -D-glucomannan.	102

Figure 17.	The effect of temperature on β -D-mannan hydrolysis by <i>Trichoderma harzianum</i> β -mannanase 6.55.	104
Figure 18.	The thermostability of <i>Trichoderma harzianum</i> β -mannanase 6.55	105
Figure 19.	The effect of pH on <i>Trichoderma harzianum</i> β -mannanase 6.55 activity.	106
Figure 20.	The influence of metal ions on the hydrolysis of locust bean gum β -D-galactomannan by <i>Trichoderma harzianum</i> β -mannanase 6.55 activity.	110
Figure 21.	The influence of detergents on β -mannanase 6.55 activity.	112
Figure 22.	The influence of methanol and ethanol upon the activity of <i>Trichoderma harzianum</i> β -D-mannanase 6.55.	113
Figure 23.	Lineweaver-Burk plot for <i>Trichoderma harzianum</i> β -mannanase 6.55 activity on locust bean gum β -D-galactomannan in the presence of Avicel PH101 or larchwood xylan.	115

ACKNOWLEDGEMENTS

Dr. K.G. Johnson guided and focused my interest in mannans and made the completion of this thesis not only possible but mannan-torrie! Thanks Ken.

The research work described in this thesis was done under the supervision of Drs. J.N. Saddler and K.G. Johnson. The time they took to evaluate and discuss this thesis with me was greatly appreciated. I would like to thank Drs., Dave Brown, Donn Kushner, and Dennis Sprott who served on the research advisory committee for this project. I also wish to thank Dr. C. Charest for reviewing sections of the thesis. I would like to thank the many people at Forintek's Eastern Laboratories, especially the members of the Bioinnovations Department, for the use of their facilities and their friendly support. The encouragement, patience, and *especially* the numerous rides to and from the labs, provided by my family and friends are gratefully acknowledged.

Most of the experimental work was carried out in the Eastern Laboratories of Forintek Canada Corporation. The protein purification work occurred at the National Research Council in Dr. K.G. Johnson's laboratory. The financial assistance of the Natural Sciences and Engineering Research Council of Canada through the postgraduate scholarship programme is gratefully acknowledged. Additional support was provided by the University of Ottawa School of Graduate Studies Scholarship Programme. Research expenses were paid in part through a two year contract (April 1988 - April 1990) held by Forintek Canada Corporation with the Canadian Forestry Service for the study of hemicellulases in the preparation of high value cellulosic materials.

INTRODUCTION

I. Research Objectives and Rationale

The growing awareness of the deleterious environmental and health effects arising from extensive use of harsh chemical processes in the pulp and paper processing, and allied wood products industries in particular, has heightened interest in the potential of less or non-toxic, biological alternatives. As a result of their potential application in waste treatment, chemical and solvent production, the processing of wood pulps, and improvement of domestic animal feed stocks, enzymes involved in the biodegradation of lignocellulosic material have received increased attention. Recent investigations have focused primarily on delignification, bleaching, and improvement of pulp properties using ligninases and hemicellulases. As different aspects of the biological degradation and modification of lignocellulosic materials have been studied, it has become clear that certain deficiencies in current knowledge limit the efficient use and optimization of the biodegradation options. Areas where current knowledge is limited include the types and nature of the chemical bonds between major lignocellulosic components, how these are formed, what types of enzyme activity are required to cleave such bonds, and the whole area of enzyme-enzyme and enzyme-substrate interactions at various stages of degradation. To place the present study of *Trichoderma harzianum* E58 β -mannanase in context, various aspects of these areas are presented.

Studies on the biodegradation of the three major components of lignocellulosic materials, cellulose, hemicellulose, and lignin, have revealed the highly heterogeneous nature of the hydrolytic enzymes involved as well as their abundance in nature. By and large, these investigations have been application-driven, and as such research activities have focused sequentially on microbial cellulases, ligninases, and more recently, on hemicellulases. When data from preliminary ligninase studies were less effective in lignin removal than originally anticipated (Haemmerli *et al.*, 1986; Viikari *et al.*, 1987), research using hemicellulases to explore hemicelluloses and their possible role in maintaining the structural integrity of the lignocellulose matrix intensified. This research focused on xylan, the major hemicellulose of hardwoods, and xylanases, the enzymes involved in its degradation.

It is known that the production of high grade dissolving wood pulp is hampered by the presence of hemicellulose impurities such as β -mannans and xyans that clog equipment and/or result in product defects. These impurities cannot be chemically removed without significant destruction of the cellulose (Hinck *et al.*, 1985). Studies on xylanases were directed towards the goal of selective modification of woody materials and the enhancement of pulp and paper properties without damage to the structure of the cellulose component of the pulp, therefore enzymes lacking cellulase activity but possessing xylanase activity were sought. From this search our understanding of the degradation of lignocellulose material was enriched. Fungi were identified as rich sources of hemicellulases of high catalytic activity which as a result of their extracellular expression could be isolated with relative ease. Unlike cellulose hydrolysis which required the synergistic interaction of three groups of enzymes, (endoglucanases, cellobiase, and

exoglucanases), (Ghose and Bisaria 1979; Mandels 1982), complete wood xylan degradation required the co-ordinated action of endoxylanases, xylobiases, and xylan substituents-hydrolyzing enzymes such as acetyl xylan esterases, α -glucuronidases, and α -arabinosidase (Biely 1985; Grohmann *et al.*, 1989; Khan *et al.*, 1989; Poutanen *et al.*, 1987; Poutanen and Sundberg 1988; Wong *et al.*, 1988).

Several reports have shown that pre-treatment with hemicellulase enzymes could reduce the amount of chlorine or chlorine dioxide required to bleach pulps, substantially reducing the production of chloro-organic material found in pulp effluents. Virtually all previous reports on the use of hemicellulases in the modification of pulps have described the results of xylanase enzyme treatments (Kantelinen *et al.*, 1988; Noe *et al.*, 1986; Paice and Jurasek 1984; Senior *et al.*, 1988; 1991). The ability of *T. harzianum* xylanases to aid in the biobleaching of a variety of hardwood (Angiosperms) and softwood (Gymnosperms) pulps has recently been assessed (Senior *et al.*, 1988; Clark *et al.*, 1990). Although a significant improvement in the hardwood pulp properties was observed, only a marginal effect on softwood pulps was obtained. This is not surprising if one considers that the hemicelluloses found in softwood pulps are predominately mannans (Table 1). Thus, the acquisition of β -mannanases capable of selectively hydrolyzing β -mannan but not cellulose is desirable. The production and characterization of such a 'cellulase-free' β -mannanase is described in this dissertation.

Table 1. The Percent Composition of Wood.

Component	Tree species		
	Aspen	White Spruce	Eastern White Pine
Cellulose	48	41	41
Lignin	21	27	29
Xylan	24	13	9
Glucomannans	3	—	—
O-acetyl-galactoglucomannans	—	18	18
Pectins, Starch, Ash, etc.	4	1	3

(From Timell 1967)

The main goals of this research were to study β -mannanase activity from *T. harzianum* E58 with respect to: 1) Detection and isolation of enzyme activity capable of selectively degrading β -D-mannan but lacking cellulase activity; 2) Factors affecting production of β -mannanase active proteins; 3) Catalytic properties of a β -mannanase and assessment of effectors which may impact on the potential application of this enzyme; 4) Evaluation of its relationship with non-mannan lignocellulosic substrates and other hemicellulases.

Trichoderma species have minimal nutritional requirements, grow rapidly, and excrete relatively high amounts of proteins at a high rate. Their metabolic versatility has been well documented and their genetics have been extensively studied (Eveleigh 1985). Such features make this fungus an appealing source of enzymes with potential industrial applications.

Although the production of cellulases and xylanases from a variety of *Trichoderma* species has been reported (Ghose and Bisaria 1979; Mandels 1982; Mes-Hartree *et al.*, 1988; Senior *et al.*, 1989a; 1989b), relatively little work describing the regulation and production of β -mannanases has been performed. The limited research that has been undertaken has shown that some *Trichoderma* species produce extracellular β -mannanases when grown on either cellulose or mannan (Khan *et al.*, 1989; Reese and Shibata 1965); however, substrate specificity and characterization of these enzymes has not been described. In this study, *T. harzianum* E58, a known producer of cellulases and xylanases (Saddler 1982; Tan *et al.*, 1985a; 1987) was selected as a potential β -mannanase source to facilitate direct comparison of the factors affecting β -mannanase production and activity with those already known to impact on the cellulase and/or

xylanase activity of the fungus. It was hoped that such comparisons would provide some insight into β -mannan degradation within the hemicellulose-cellulose matrices found in nature.

Since Canada is the world's largest exporter of softwood pulps, enzymes capable of modifying the softwood hemicelluloses would have great potential in current Canadian pulp and paper operations. That mannanases alone or in combination with other hemicellulases might be more effective than xylanases alone in the removal of mannans in softwood pulps is probable. For example, a recent study (Clark *et al.*, 1990) indicated that β -D-mannanase treatment of radiata kraft pulps could reduce the chlorine bleaching requirement by approximately 25%. Because of the beneficial environmental impact, this potential application of mannan specific enzymes has generated a renewed interest in the purification and characterization of β -D-mannanases and their use in the selective removal of mannans from wood (Araujo and Ward 1990b; 1990c; Johnson *et al.*, 1990; Johnson and Ross 1990; Rättö and Poutanen 1988; Talbot and Sygusch 1990).

II. The Structure of Wood

An appreciation of the issues of selective enzymatic degradation of mannans, and wood mannans in particular, requires a basic understanding of the chemistry and structure of wood and β -mannans. Wood is composed primarily of plant lignocelluloses which are the most abundant naturally occurring polymers (Dekker 1985). Lignocelluloses are heterogenous matrices consisting of: cellulose, a β -linked glucose homopolysaccharide; lignin, a polyphenolic complex; and hemicellulose containing polymers of alkali soluble β -D-mannan and/or β -D-xylan (Figure 1).

Figure 1. The association of cellulose, hemicellulose and lignin within wood lignocellulose, a) Transverse section; b) Longitudinal section through wood cell wall (adapted from Fengel and Wegener 1983).

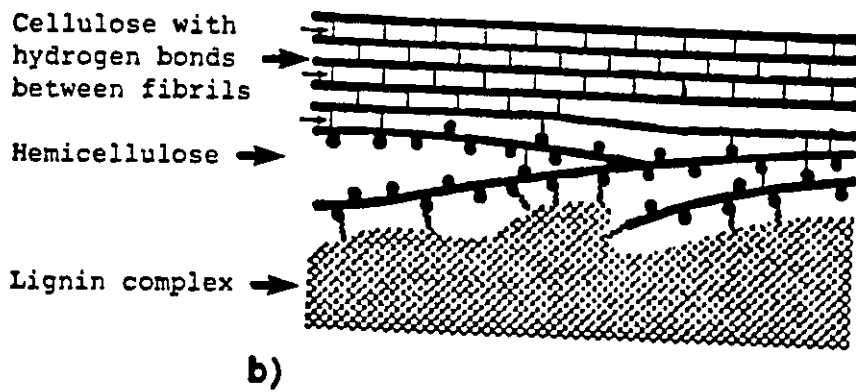
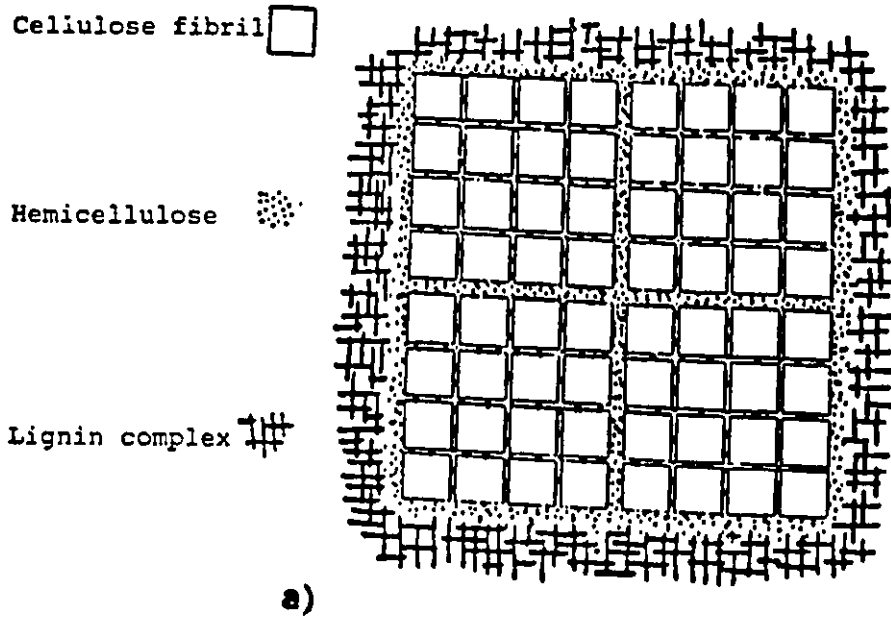

The wood cell wall is believed to be composed of a cellulose framework encrusted by lignin within a hemicellulose matrix that may act as a kind of glue (Fengel and Wegener 1983; Meier 1985). A representation of mature woody tissue appears in Figure 1. Typically, the wood matrix is composed of; 20 - 30% lignin, 40 - 60 % cellulose, and 10 - 30% hemicellulose (Fengel and Wegener 1983; Timell 1967). There are two types of plant cell wall layers which are referred to as the primary and the secondary cell walls. The area between plant cells, beside the primary layer is called the lamella (Figure 2a) (Fengel and Wegener 1983). The primary layer is the first layer laid down along the newly formed cell plate during anaphase of mitotic nuclear division (Burgess 1985). Secondary layers are deposited on top of the primary wall after its growth has ceased and lignification, the thickening of the cell wall layer by the addition of lignin compounds, has begun (Burgess 1985; Harada and Cote 1985; Sjöström 1981). Most of the hemicellulose is located in the secondary layers of the cell wall (Goodwin 1983, Meier 1985). The precise role of the hemicellulose polymers is not known, although it has been suggested that they mediate linkages between lignin and cellulose (Fengel and Wegener 1983; Sjöström 1981). In the secondary layers hemicellulose polymers are thought to direct cellulose microfibrils into their characteristic helicoidal arrangement (Figure 2b) (Neville 1988). The exact proportion of lignin, cellulose, xylan and mannan within a given wood depends upon the tree species and varies with the age of the tree (Harada and Cote 1985; Meier 1985). Xylans are the major hemicellulose of all hardwoods. In softwoods, the major wood resource within Canada, the hemicellulose component is 50-85% mannan. Yet, wood mannans and their degradation have not been as extensively studied as cellulose or xylan.

Figure 2. The schematic representation of woody cell wall structure, a) Simplified structure of a woody cell; ML-lamella, P-primary layer, S1, S2, and S3-secondary layers, (from Sjoström 1981); b) Diagrammatic representation of the possible role of hemicellulose in the orientation of microfibrils in the cell wall of woody tissue. The hemicellulose is represented as dark pipe cleaner shaped chains between parallel layers of cellulose microfibrils (from Neville 1988).

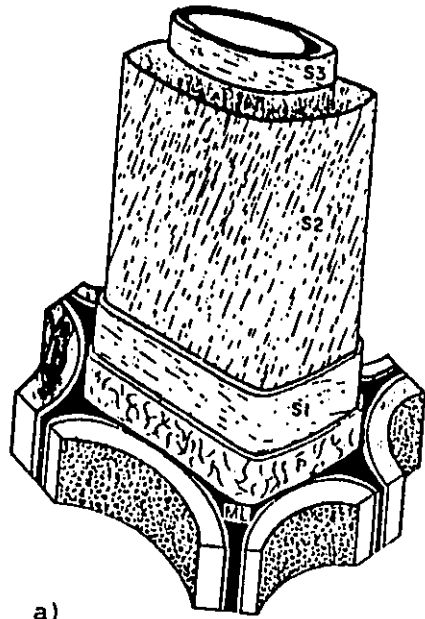

a)

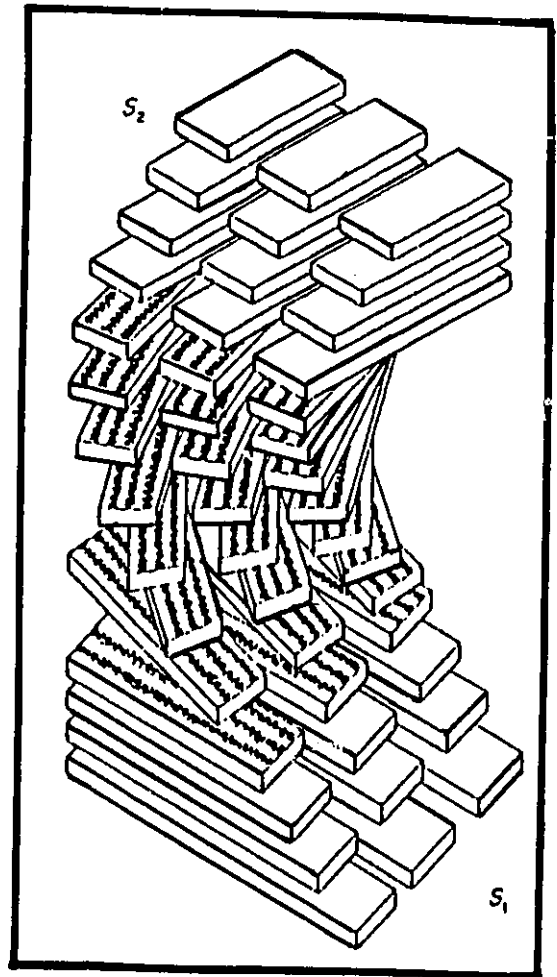

b)

III. The Composition and Structure of Mannans

Mannan is a generic term referring to any polysaccharide containing mannopyranosyl units as major components. Mannans, classified as either α or β according to the glycosidic linkage of the mannopyranosyl unit, are widely distributed in nature and are distinguished by their diverse composition and large degree of structural complexity. α -Mannans are found in the cell walls of yeast, fungal mycelia, and glycoprotein complexes. β -Mannans include industrial gums such as guar, xanthan and locust bean gum. Xanthan is an exopolysaccharide of the bacterium, *Xanthomonas campestris* and possesses both α and β -linked mannose (Kierulf and Sutherland 1988; McNeely and Kang 1973; Sutherland 1984). β -Mannans are found in seed endosperm (Meier 1985), algae (Levin 1974; MacKie and Preston 1974) and are the major hemicellulose of softwoods. Most β -mannans studied have been isolated from plant material. β -Mannans have been reported, in Orchidaceae and Araceae tubers, in Liliaceae leaves and bulb scales (Meier and Reid 1982), in fern stem tissue (Bremner and Wilke 1971), as a reserve polysaccharide in the endosperm of legume seeds (Meier and Reid 1982) and coffee beans (Hashimoto and Fukumoto 1969; Wolfrom *et al.*, 1961), in *Aloe arborescens* leaves (Wozniowski *et al.*, 1990), as well as in woody materials (Fengel and Wegener 1983; Timell 1961). Since the majority of mannans found in wood are β -mannans and since the potential application of the mannanase described in this thesis is the selective hydrolysis of wood mannans, this review will be limited to β -mannans and the enzymes reported to degrade them.

Pure mannans have been defined as those mannans containing less than 10% non-mannose sugar residues and have been shown to be a major part of the dry weight of palm seeds such as ivory nut (Meier and Reid 1982). Most mannans are complex heteropolysaccharides (Table 2). Many β -mannans contain glucopyranosyl units within their backbone and are designated glucomannans. The konjac β -mannan isolated from tubers of *Amorphophallus konjac* (Kato and Matsuda 1972; Smith and Srivastava 1959) is an example of a β -D-glucomannan. Other β -mannans, such as guar and locust bean gum possessing α -linked galactose branches are referred to as β -D-galactomannans. Xanthan is an example of a complex mannan containing glucose, glucuronate, and mannose in a ratio of 2.8 : 2 : 2 with extensive α (1,3) and α (1,2) linked mannose side chains as well as β -linkages (McNeely and Kang 1973; Muller and Lecourtier 1988). A further degree of complexity arises from the fact that mannans frequently possess acetyl groups and other acidic groups bound by ester linkages to the free hydroxyl groups of the sugar residues within the polysaccharide backbone (Bacon 1979). The position of these linkages within mannans is believed to be random and in many mannans the degree of *in vivo* substitution is still debated. Similarly, the arrangement of mannopyranosyl and glucopyranosyl units within the backbone of most glucomannans is believed to be random (Meier and Reid 1982). The distribution pattern of D-galactosyl residues along the β -D-mannan chain of most β -D-galactomannans is also thought to be irregular (McCleary 1988b; McCleary and Matheson 1986).

Polysaccharides, like proteins, possess secondary and tertiary structure. For example, cellulose molecules form hydrogen bonds with one another giving rise to a complex of microcrystalline and amorphous regions (Neville 1988). Mannan gums form

Table 2. The Structural Diversity of Mannans.

Mannan Source	Structural Unit ^a	References
Ivory nut	β Man β Man β Man β	Chanzy <i>et al.</i> , 1979.
Yeast (cell wall)	$ \begin{array}{c} \alpha \text{ Man } \alpha \text{ Man } \alpha \text{ Man } \alpha \\ \qquad \qquad \\ \alpha \text{ Man } \quad \alpha \text{ Man} \\ \qquad \qquad \\ \alpha \text{ Man } \quad \alpha \text{ Man} \end{array} $	Nakajima and Ballou 1974.
Konjac root powder (<i>Amorphophalus konjac</i>) Man:Glu = 3.1:2 (actual arrangement of monomers not determined)	β Man β Glu β Man β Man β Glu β	Chanzy <i>et al.</i> , 1982. Bewley and Reid 1985.
Coffe bean Man:Gal = 47:1	$ \begin{array}{c} \beta \text{ Man } (\beta \text{ Man } \beta \text{ Man } \beta)_{48} \\ \\ \alpha \text{ Gal} \end{array} $	Wolfrom <i>et al.</i> , 1961.
Guar bean gum Man:Gal = 65:35	$ \begin{array}{c} \beta \text{ Man } \beta \text{ Man } \beta \\ \\ \alpha \text{ Gal} \end{array} $	Emi <i>et al.</i> , 1972.
<i>Melilotus officinalis</i> seeds Man:Gal = 1.1:1	$ \begin{array}{c} \beta(\text{Man } \beta \text{ Man})_b \beta \text{ Man } \beta(\text{Man } \beta \text{ Man})_c \\ \qquad \qquad \qquad \qquad \\ \alpha \text{ Gal } \quad \alpha \text{ Gal } \qquad \quad \alpha \text{ Gal} \\ \qquad \qquad \qquad \qquad \qquad \qquad \qquad b + c = 9 \end{array} $	Gupta and Grasdalen 1988.
Locust bean gum (carob) <i>Ceratonia siliqua</i> Man:Gal = 2.8:1 to 6.3:1 (varies with growth conditions)	$ \begin{array}{c} \beta \text{ Man } \beta \text{ Man } \beta \text{ Man } \beta \text{ Man } \beta \\ \\ \alpha \text{ Gal} \end{array} $	Rol 1973. Winter <i>et al.</i> , 1987.

^a Symbols for subunits are: β) β -1,4 linkages; α) α linkages; Man) mannose, Glu) glucose, Gal) galactose.

gels in which water becomes part of the ordered structure of the mannan in solution. Bacon (1979) suggested that the subjects of secondary and tertiary structure and subunit binding normally associated with research in protein chemistry are also important aspects that must be considered in attempts to elucidate the structure and the biodegradability of polysaccharides. The frequency and position of galactosyl, acetyl groups, and/or other acid substituents along the main chain of a polysaccharide affect the configuration of the polysaccharide as well as its interaction with other polysaccharides. For example, Rees (1977) described the tertiary structure of certain galactomannans and glucomannans as helical-ribbons which because of their heteropolysaccharide nature and their substituent groups possessed greater flexibility and accessibility than cellulose. He suggested that the more ordered the structure of a polysaccharide, the more difficult it would be to hydrolyze (Rees 1977). Shatwell and his coworkers (Shatwell *et al.*, 1991a; 1991b; 1991c) found that the degree of acetylation of xanthan influenced its association with guar gum, locust bean gum and konjac β -D-glucomannan. Furthermore, Maekajji (1974) suggested that the acetyl groups present in konjac β -D-glucomannan suppressed intermolecular hydrogen bonding, thereby altering tertiary structure, and that their removal decreased the solubility of the polymer. In his studies on the relationship between the enzymatic hydrolysis of β -D-galactomannans and konjac β -D-glucomannan and their secondary structure, McCleary (McCleary 1986; McCleary and Matheson 1975; 1983; 1986) found that the primary and secondary structure of the mannan affected the extent of hydrolysis. The above observations support Bacon's (Bacon 1979) argument that the subjects of primary, secondary, and tertiary structure are important aspects to consider in any attempts to elucidate the structure and biodegradability of polysaccharides.

Certainly the primary, secondary, and tertiary structure of β -D-mannans remain to be resolved. Difficulties in the analysis and comparison of reported β -D-mannanase activities arise, in part, from the lack of knowledge of the structure of β -D-mannans and result in ambiguity in the use of the terms mannan, glucomannan, galactoglucomannan, galactomannan, and mannan degrading enzyme.

A. *Wood mannans.*

Like the non-wood mannans described previously, wood mannans are complex heteropolysaccharides whose primary and secondary structure *in vivo* has yet to be resolved. A universal model of a typical wood mannan is not possible because composition differs among taxa and changes with age and in response to the environmental stresses the tree has experienced. While hardwoods contain only 3 - 5 % glucomannan, softwoods contain 20 - 30% glucomannan (Fengel and Wegener 1983). Reaction or tension wood contains less galactoglucomannan than normal wood (Timell 1982). A major deterrent to a precise description of wood mannan structure resides in the methods of mannan extraction. For example, acetyl groups can be removed and partial hydrolysis of the polysaccharide can occur during isolation procedures (Sjöström 1981). This may account for some of the variations that have been reported in the proportion of mannose : glucose : galactose and the degree of acetylation of mannans isolated from the same species, (Fengel and Wegener 1983). Nevertheless, general statements about wood mannans can be made. The structure of mannans is similar in both hardwoods and softwoods wherein galactose may be linked by α -1,6 bond to the mannose units within the β -1,4 glucomannan backbone. This backbone does not have a simple repeating unit.

Three or more mannose or glucose units may be bound to each other along the backbone before the insertion of the other sugar unit. Hardwoods contain β -D-glucomannans with the mannose to glucose ratio in the backbone of the molecule varying from 1:1 to 2:1. By contrast, softwood mannan has a backbone containing mannose and glucose in a ratio of approximately 3 : 1 (Figure 3). Softwood β -D-galactoglucomannans that have acetyl groups attached to the β -D-glucomannan backbone are referred to as O-acetyl-galactoglucomannans (Fengel and Wegener 1983). The term softwood mannan is often used to refer to both softwood β -D-glucomannans and β -D-galactoglucomannans.

IV. Enzymatic Degradation of Mannans

Heteropolymeric β -D-mannans are used in the paper, textile, food, pharmaceutical, explosive manufacture, oil recovery and dye industries. The abundance of β -D-mannans in nature and their high degree of heterogeneity with respect to chemical composition and structure implies that enzymes involved in their degradation would be equally diverse and abundant especially among the fungi which are the organisms responsible for much of the plant degradation in nature. In spite of their industrial importance and prevalence in nature, little data were available, until recently, regarding the physicochemical characteristics of the individual fungal enzymes involved in the degradation of these β -D-mannans. Several fungi and bacteria are reported to produce mannanases and enzymes with β -mannanase activity have been purified from plant seeds. To date, few studies have reported the characteristics of the individual fungal or bacterial enzymes capable of degrading wood mannans.

Figure 3. Partial chemical structure of O-acetyl-galactoglucomannan from softwood
(from Fengel and Wegener 1983).

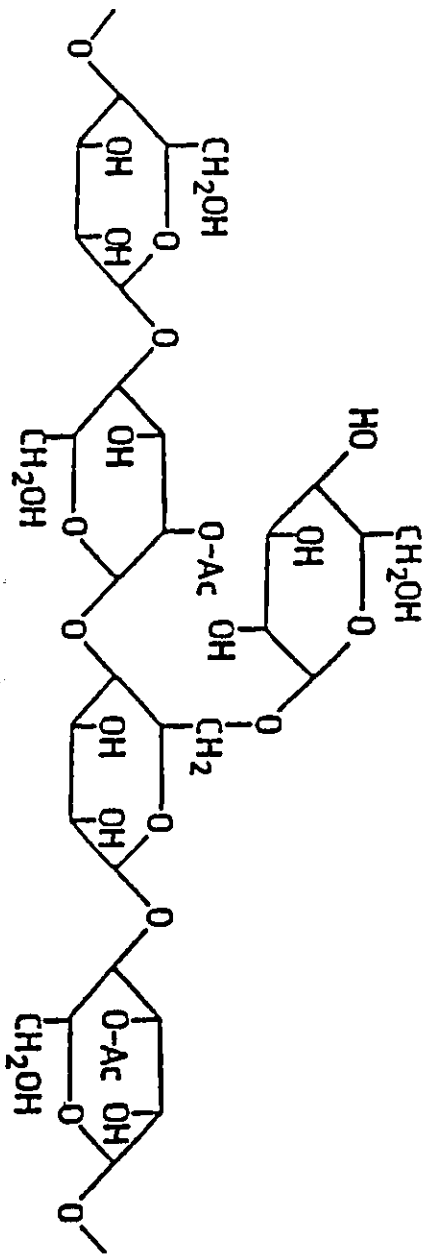

Commercial preparations of enzyme mixtures of *Bacillus* spp. and *Aspergillus* spp. having β -mannanase activity are available (Novo Laboratories Ltd.). Researchers in New Zealand (Clark *et al.*, 1988; 1990) have assessed the potential of commercial sources of β -mannanase to degrade *Pinus radiata* mannans. Sinner and his co-workers (1976) found β -mannanase isolated from a commercial preparation of *Aspergillus* spp. did not significantly degrade sprucewood holocellulose although it was capable of completely hydrolyzing guar gum β -D-galactomannan. However, in a later study they (Sinner *et al.*, 1979) reported that 25% of the mannan was removed from sprucewood holocellulose after 5 days of treatment with an enzyme fraction obtained from a commercial preparation of *Aspergillus niger*.

Even fewer reports describing the ability of fungal β -mannanases from non-commercial preparations to degrade wood mannans are available. Ishihara and Shimizu (1980; Shimizu and Ishihara 1983), used larchwood glucomannan to characterize β -mannanase activity of *Tyromyces palustris* in media of low pH (pH 5 -2.8). Recently, the ability of β -mannanases purified from *Polyporus versicolor* cultures to release reducing sugars from aspen lignin-carbohydrate complexes was measured (Overend and Johnson 1991). Comprehensive reviews of microbial β -D-mannan degradation have been presented by Dekker (Dekker 1979, Dekker and Richards 1976) and earlier by Reese and Shibata (1965). McCleary summarized studies detailing the degradation of vegetable β -D-mannans (McCleary 1986; 1988a; McCleary and Matheson 1983; McCleary *et al.*, 1983). Many of these studies had been carried out within his research group. Recent reports describing the microbial degradation of β -D-mannans are summarized in Table 3.

Table 3a. Identification of β - Mannanase Producing Bacteria.

Organism	Growth Substrate ^a (%w/v)	Assay Substrate ^a (%w/v)	Assay Conditions	Activity Level Reported ^b	References
<i>Actinomyces</i> various strains	copra mannan (1%)	copra mannan (1%)	40°C, 30 min Somogyi assay	1 - 11.4 mg/10 mL/ml filtrate/30 min	Takahashi <i>et al.</i> , 1983
<i>Aeromonas hydrophila</i>	konjac (0.5%)	<i>Codium</i> mannan (0.4%)	37°C, 10 min N/S assay	0.446 U/ mg protein	Araki 1983
<i>Alcaligenes</i> app.	<i>Codium fragile</i> mannan (1.5%)	<i>Codium fragile</i> mannan (1.5%)	25°C, 2 days +/- clearing zone on agar	+ clearing	Araki and Kitamikado 1978
<i>Bacillus brevis</i> ATYC 8186	locust bean (1%) + 20%v/v potato extract + corn steep solids (0.1%)	locust bean (0.5%)	50°C, 30 min DNS reducing sugar assay	1.9 U/ml filtrate	Araujo and Ward 1990b
<i>Bacillus cereus</i>	as above	as above	as above	2.4 U/ml filtrate	as above
<i>Bacillus cereus</i>	N.R.	guar gum (0.5%)	30°C, 8 days % original viscosity remaining	134.6%	Souw and Rehm 1975
	N.R.	locust bean (0.5%)	as above	7%	as above
<i>Bacillus circulans</i> 215	konjac (0.5%)	konjac (0.5%)	30°C N/S assay	0.025 mM/min/ mg protein	Ogawa <i>et al.</i> , 1987

continued....

Table 3a. *continued....*

Organism	Growth Substrate (%w/v)	Assay Substrate (%w/v)	Assay Conditions	Activity Level Reported ^a	References
<i>Bacillus circulans</i> ATCC 4513	locust bean (1%) + 20%v/v potato extract + corn steep solids (0.1%)	locust bean (0.5%)	50°C, 30 min DNS reducing sugar assay	0.9 U/ml filtrate	Araujo and Ward 1990b
<i>Bacillus coagulans</i>	N.R.	guar gum (0.5%)	30°C, 8 days % original viscosity remaining	9.8 %	Souw and Rehm 1975
	N.R.	locust bean (0.5%)	as above	138 %	as above
<i>Bacillus firmus</i>	N.R.	guar gum (0.5%)	30°C, 8 days % original viscosity remaining	13.7 %	Souw and Rehm 1975
	N.R.	locust bean (0.5%)	as above	14.7 %	as above
<i>Bacillus lentus</i>	N.R.	guar gum (0.5%)	as above	9.8 %	as above
	N.R.	locust bean (0.5%)	as above	12.9 %	as above
<i>Bacillus licheniformis</i>	N.R.	guar gum (0.5%)	as above	10.2 %	as above
	N.R.	locust bean (0.5%)	as above	7.7 %	as above
<i>Bacillus licheniformis</i> ATCC 27811	locust bean (1%) + 20%v/v potato extract + corn steep solids (0.1%)	locust bean (0.5%)	50°C, 30 min DNS reducing sugar assay	1.5 U/ml filtrate	Araujo and Ward 1990b

continued....

Table 3a. continued....

Organism	Growth Substrate (%w/v)	Assay Substrate (%w/v)	Assay Conditions	Activity Level Reported ^a	References
<i>Bacillus magisterium</i> ATCC 14581	locust bean (1%) + 20%v/v potato extract + corn steep solids (0.1%)	locust bean (0.5%)	50°C, 30 min DNS reducing sugar assay	0.7 U/ml filtrate	Araujo and Ward 1990b
<i>Bacillus polymyxa</i> NRRL 842	as above	as above	as above	4.1 U/mL filtrate	as above
<i>Bacillus pumilus</i>	locust bean (0.5%)	locust bean (0.5%)	50°C, 30 min DNS sugar assay	34 U/mL filtrate	Araujo and Ward 1990c
<i>Bacillus stearothermophilus</i> ATCC 266	locust bean (1%)	locust bean (0.2%)	55°C, 5 min DNS reducing sugar assay	2.3 U/mg protein	Talbot and Sygusch 1990
<i>Bacillus</i> spp. AM-001	konjac (1.0%) {screened on 1% larchwood}	konjac (0.5%)	50°C, 10 min N/S assay	23 U/mg protein	Akino <i>et al.</i> , 1987
<i>Bacillus subtilis</i> (various strains)	locust bean (1%) + 20%v/v potato extract + corn steep solids (0.1%)	locust bean (0.5%)	50°C, 30 min DNS reducing sugar assay	7.6 - 106.2 U/ mL filtrate	Araujo and Ward 1990b
<i>Bacillus subtilis</i> ATCC 12711	wheat bran (3%)	locust bean (0.5%)	50°C, 10 min N/S assay	30 nkat/mL	Rätüš and Poutanen 1988
	wheat bran (3%) plus locust bean (0.5%)	as above	as above	256 nkat/mL	as above
<i>Bacillus subtilis</i> K50	soybean extract (5.0%)	coffee mannan (1%)	40°C, 5 min Shaffer-Somogyi sugar assay	65 U/mL filtrate	Emi <i>et al.</i> , 1972

continued....

Table 3a. *continued....*

Organism	Growth Substrate (%w/v)	Assay Substrate (%w/v)	Assay Conditions	Activity Level Reported*	References
<i>Bacteriodes ovatus</i> ATCC 8433 (outer membrane)	guar gum (0.5%)	guar gum (0.5%)	37°C, 15 min Dyggert reducing sugar assay	190.8 µg/min	Gherardini and Salyers 1987a
<i>Bacteriodes ovatus</i> ATCC 8433 (cell wall)	as above	as above	as above	384 µg/min	Gherardini and Salyers 1987b
<i>Cellulomonas</i> spp. ATCC 21399	Avicel (2%)	locust bean (0.5%)	50°C N/S assay	20 - 130 U/mL	Poulsen and Petersen 1989
<i>Enterobacter</i> spp.	<i>Codium fragile</i> mannan (1.5%)	<i>Codium fragile</i> mannan (1.5%)	25°C, 2 days +/- clearing zone on agar	+ clearing	Araki and Kitamikado 1978
<i>Klebsiella</i> spp.	as above	as above	as above	+ clearing	as above
<i>Moraxella</i> spp.	as above	as above	as above	+ clearing	as above
<i>Pseudomonas</i> spp.	as above	as above	as above	+ clearing	as above
<i>Pseudomonas</i> spp. PT-5	<i>Prophra tenera</i> (0.25%)	konjac (0.16%)	35°C N/S assay	0.52 U/mg protein	Yamaura <i>et al.</i> , 1990
<i>Streptomyces</i> No.17	copra mannan (2%)	copra mannan (1%)	40°C, 30 min Somogyi assay	2220 mg/10 mL/ml filtrate/30 min	Takahashi <i>et al.</i> , 1984

continued...

Table 3a. continued....

Organism	Growth Substrate (%w/v)	Assay Substrate (%w/v)	Assay Conditions	Activity Level Reported ^a	References
<i>Streptomyces olivo-chromogenes</i> ATCC 21713	wheat bran (3%)	locust bean (0.5%)	50°C, 10 min N/S assay	9 nkat/mL	Rättö and Poutanen 1988
	wheat bran (3%) plus locust bean (0.5%)	as above	as above	45 nkat/mL	as above

^a Locust bean refers to locust bean gum powder or the β -galactomannan extracted from it. The term konjac refers to konjac root powder or the β -D-glucomannan extracted from it.

^b Results reported from sugar assays are expressed as the amount of reducing sugar released, where mannose or glucose is used as the assay standard. Units of activity, (U) are usually expressed as μ moles reducing sugar released per minute.

N/S = The Nelson Somogyi reducing sugar assay.

N.R. = Information not reported.

Table 3b. Identification of β - Mannanase Producing Fungi.

Organism	Growth Substrate ^a (%w/v)	Assay Substrate ^a (%w/v)	Assay Conditions	Activity Level Reported ^b	References
<i>Aspergillus awamori</i>	wheat bran (3%)	locust bean (0.5%)	50°C, 10 min N/S assay	21 nkat/mL	Ritüš and Poutanen 1988
	wheat bran (3%) plus locust bean (1%)	as above	as above	34 nkat/mL	as above
<i>Aspergillus niger</i>	commercial source (Miles Lab.)	RBB-carob galactomannan (0.2%)	40°C, 10 min ΔOD 590nm/min standardized against N/S assay	6.5 U/mg protein	McCleary 1988a
<i>Aspergillus niger</i> NRRL 337	locust bean (1%)+ (20%) v/v + potato extract + corn steep liquor (0.1%)	locust bean (0.5%)	50°C, 30 min DNS reducing sugar assay	5.2 U/mL filtrate	Araujo and Ward 1990a
<i>Aspergillus tamarri</i>	<i>Trifolium repens</i> (white clover) (0.1%)	Salep glucomannan (0.05%)	37°C, N/S assay	2.9 U/mg protein	Civas <i>et al.</i> , 1984
<i>Glionatz trabeum</i> NRCC 5907	wheat bran (1%)	konjac (0.2%)	50°C, 15 min N/S assay	2.7 U/mg protein	Johnson 1990
<i>Haematosterium sanguinolenum</i> NRCC 5902	as above	as above	as above	10.9 U/mg protein	Johnson 1990
<i>Lenzites saepiaria</i> NRCC 5910	wheat bran (1%)	as above	as above	5.2 U/mg protein	Johnson 1990

continued...

Table 3b. continued...

Organism	Growth Substrate (%w/v)	Assay Substrate (%w/v)	Assay Conditions	Activity Level Reported*	References
<i>Neocallimastix patriciarum</i>	oat spelt xylan (0.5%)	guar gum (0.5%)	39°C, 60 min Lever reducing sugar assay	239 nmol/ mg protein/h	Williams and Orpin 1987
	cellobiose (0.5%)	as above	as above	471 nmol/ mg protein/h	as above
	glucose (0.5%)	as above	as above	263 nmol/ mg protein/h	as above
<i>Penicillium purpurogenum</i>	white copra meal (4%) + 0.5% corn steep liquor	copra mannan (1%)	50°C, 30 min Somogyi assay	0.7 U/mg protein	Park <i>et al.</i> , 1987
<i>Phoma hibernica</i> PE-55	filter paper	poly - D - galactomannan (0.125%)	30°C, 30min Nelson reducing sugar assay	9.5 μ mol/ 30 min/ mg protein	Urbanek and Zalewako-Sobezak 1988
	filter paper	glucomannan sulfite hemlock (0.125%)	as above	3.0 μ mol/ 30min	Urbanek <i>et al.</i> , 1978
	filter paper	kraft hemlock galactoglucomannan (0.125%)	as above	3.4 μ mol/ 30min	Urbanek <i>et al.</i> , 1978
<i>Polyporus versicolor</i> NRCC 5909	wheat bran (1%)	konjac (0.2%)	50°C, 15 min N/S assay	8.3 U/mg protein	Johnson 1990
	locust bean (0.1%)	as above	as above	3.42 U/mg protein	as above
	oat-spelta xylan (1%)	as above	as above	0.62 U/mg protein	as above
	acid-swollen avicel (1%)	as above	as above	0.15 U/mg protein	as above

continued...

Table 3b. continued...

Organism	Growth Substrate (%w/v)	Assay Substrate (%w/v)	Assay Conditions	Activity Level Reported*	References
<i>Polyporus versicolor</i> NRCC 5909	avicel (1%)	konjac (0.2%)	50°C, 15 min N/S assay	1.08 - 3.99 U/mg protein	Johnson 1990 and Johnson <i>et al.</i> , 1990.
	avicel (1%)	locust bean (0.2%)	50°C, 15 min N/S assay	3.42 U/mg protein	Johnson 1990
	avicel (1%)	guar gum (0.2%)	as above	0 U/mg protein	Johnson 1990
<i>Poria placenta</i>	locust bean (0.1%) + Solka-Floc (0.5%) + glucose (0.5%) + hemlock sawdust (0.5%)	lobolly pine (0.5%)	40°C, 60 min N/S assay	4.4 μ mol/ mg protein/h	Highley <i>et al.</i> , 1981
	locust bean (0.1%) + Solka-Floc (0.5%) + glucose (0.5%) + sweetgum sawdust (0.5%)	lobolly pine (0.5%)	40°C, 60 min N/S assay	14.5 μ mol/ mg protein/h	Highley <i>et al.</i> , 1981
<i>Poria placenta</i>	wheat bran (1%)	konjac (0.2%)	50°C, 15 min N/S assay	8.2 U/mg protein	Johnson 1990
<i>Sporotrichum cellulophilum</i> ATCC 20493	locust bean (1%) + (20%) v/v + potato extract + corn steep (0.1%)	locust bean (0.5%)	50°C, 30 min DNS reducing sugar assay	4.8 U/mL filtrate	Araujo and Ward 1990a
<i>Schizophyllum commune</i> NRCC 5911	wheat bran (1%)	konjac (0.2%)	50°C, 15 min N/S assay	2.4 U/mg protein	Johnson 1990

continued...

Table 3b. continued...

Organism	Growth Substrate (%w/v)	Assay Substrate (%w/v)	Assay Conditions	Activity Level Reported ^a	References
<i>Talaromyces</i> <i>byssochlamydioides</i> NRRL 3658	locust bean (1%)+ 20% v/v + potato extract + corn steep liquor (0.1%)	locust bean (0.5%)	50°C, 30 min DNS reducing sugar assay	4.8 U/mL filtrate	Araujo and Ward 1990a
<i>Talaromyces</i> <i>emersonii</i> NRRL 3221	as above	as above	as above	43.1 U/mL filtrate	Araujo and Ward 1990a
<i>Talaromyces</i> <i>emersonii</i> ATTC 18080	as above	as above	as above	0.6 U/mL filtrate	Araujo and Ward 1990a
<i>Thielavia</i> <i>terrestris</i> NRRL 8126	locust bean (1%)+ 20% v/v + potato extract	locust bean (0.5%)	50°C, 30 min DNS reducing sugar assay	6.7 U/mL filtrate	Araujo and Ward 1990d
<i>Trichocladium</i> <i>condense</i> NRCC 5903	wheat bran (1%)	konjac (0.2%)	50°C, 15 min N/S assay	3.5 U/mg protein	Johnson 1990
<i>Trichoderma</i> <i>reesei</i>	wheat bran (3%)	locust bean (0.5%)	50°C, 10 min N/S assay	11 nkat/mL	Rätö and Poutanen 1988
	wheat bran (3%) + locust bean (1%)	as above	as above	24 nkat/mL	as above
<i>Tyromyces</i> <i>palustris</i> IV	glucose (2%) + birch meal (0.5%)	larchwood glucomannan (0.4%)	40°C, 10 min N/S assay	228.74 ΔOD 660nm/min	Ishihara and Shimizu 1980

^a Locust bean refers to locust bean gum powder or the β-D-galactomannan extracted from it. The term konjac refers to konjac root powder or the β-D-glucomannan extracted from it.

^b Results reported from sugar assays are expressed as the amount of reducing sugar released, where mannose or glucose is used as the assay standard. Units of activity, (U) are usually expressed as μmoles reducing sugar released per minute.

N/S = The Nelson Somogyi reducing sugar assay.

N.R. = Information not reported.

Past research into β -mannanases has focused primarily on the degradation of vegetable mannans such as guar and locust bean gums. The majority of bacterial enzymes having β -mannanase activity have been obtained from *Bacillus* species. A β -mannanase from *Bacillus subtilis* capable of degrading guar gum and konjac β -D-glucomannan was crystallized and its activity was described by Emi and his colleagues (1972). Talbot and Sygusch (1990) have purified a thermostable β -mannanase from *Bacillus stearothermophilus*. Akino and his co-workers (Akino *et al.*, 1987; 1988) explored cell-associated enzymes produced by alkalophilic *Bacillus* spp. capable of degrading konjac, guar gum, and locust bean gum mannans. They have successfully cloned the *Bacillus* β -mannanase gene into *Escherichia coli* and have begun to study the structure and function of the enzyme using these clones (Akino *et al.*, 1989a; 1989b). Gherardini and Salyers (1987a; 1987b) studied anaerobic guar gum degradation by cell-associated and membrane bound β -galactomannanases of *Bacteriodes ovatus*. Akari and Kitamikado (1988) reported on the specificity of β -mannanase from *Aeromonas hydrophila* using a variety of vegetable mannans as assay substrates. McCleary and his co-workers have evaluated the degradation of vegetable mannans by commercially available enzyme preparations and by crude extracts from *A.niger* and *Bacillus subtilis*, legume seeds and *Helix pomatia* gut extract (McCleary 1979b; 1983a; 1986; 1988b; McCleary *et al.*, 1983). The properties of a β -mannanase isolated from commercial preparations of *Aspergillus niger* have been reported (Yamazaki *et al.*, 1976; Yamazaki and Dietrichs 1979). Araujo and Ward (1990d) described four β -mannanases that had been purified from culture filtrates of the thermophilic fungi *Thielava terrestris* and were active on coffee bean β -D-mannan and locust bean gum β -D-galactomannan.

A. Classification and detection of β -mannanase activity.

Enzymes are known to attack polysaccharides by either removing one or two sugars from the non-reducing end of the chain (exo-hydrolysis) or by cleaving bonds within the chain itself (endo-hydrolysis). All the β -mannanases characterized to date, with the exception of two β -mannanases, one isolated from *Aeromonas hydrophilia* (Araki and Kitamikado 1988) and another isolated from germinating guar seeds (McCleary 1983b; 1988c), act by cleaving bonds within the polysaccharide chain to produce a mixture of small oligomers and are, therefore, considered to be endo- β -mannanases. None of the enzymes isolated to date has been reported to be capable of cleaving both alpha and beta linked mannose subunits. β -Mannanase activity has been detected in the culture filtrates of microbes grown on a variety of substrates and activity has been measured using a variety of different assays and β -D-mannan substrates.

That growth substrates can affect the level of β -mannanase activity detected has been documented (Araujo and Ward 1990a; Highley *et al.*, 1981; Johnson 1990), (Table 3). Lyr (1963) reported that higher extracellular β -mannanase levels were obtained when various fungi were grown on cellulose compared with growth on mannan-rich substrates. Moreover, the number and quality of β -mannanases detected can also be affected by the growth substrate (Torrie *et al.*, 1991). Thus, the use of different growth substrates to screen microbes for β -mannanase production generates some ambiguity in the reported enzyme activity levels.

In addition, the use of different assay techniques makes direct comparisons of β -mannanase levels even more difficult. Variation in the ability of isolated β -mannanases

to hydrolyze different β -mannans is well documented (Akino *et al.*, 1987; Emi *et al.*, 1972; Ghose *et al.*, 1985; McCleary 1979b; 1986; 1988a; 1991; McCleary and Matheson 1983; Reese and Shibata 1965) (Table 3). This ability varies according to the number and pattern of glucopyranosyl subunits within the main chain and the pattern and frequency of substituent groups along the chain. For example, Johnson (1990) reported that the exocellular β -mannanases from *Polyporus versicolor* grown on 1% (w/v) Avicel, were able to hydrolyze a β -D-glucomannan from konjac root powder and a β -D-galactomannan from locust bean gum, but not a β -D-galactomannan from guar gum, apparently because of the high degree of galactosyl side groups occurring in this substrate (Table 3). In reviewing Table 3 it is apparent that reported β -mannanase assays also vary in the temperature of incubation, length of incubation, substrate concentration, buffer system and pH as well as the method used to measure hydrolysis. Many of these variables affect the solubility and tertiary structure of the assay substrate as well as the stability and activity of the enzymes under assessment. Thus, it is difficult to compare the β -mannanase activities reported in the literature.

There is a definite need for an IUPAC (International Union of Pure and Applied Chemistry), standard for measuring and reporting β -mannanase activity. Although IUPAC has recommended standard assay methods for reporting and measuring cellulase activity (Ghose 1987) and assays are currently being developed to standardize the methods used to measure xylanase activity, no standard β -mannanase assay has been adopted. In summarizing the recommendations of the IUPAC cellulase committee, Ghose (1987) maintained that cellulase activity and cellulose degradation were complex matters involving feedback mechanisms, transglycosylation, and a variety of end-products. Ghose

referred to celluloses as "a variable and undefined substrate whose precise structure is still unknown". He also found that the variety of sources of celluloses used as assay substrates has complicated comparisons with and interpretation of the values in the literature and therefore, advocated the development and use of a standard substrate. All the problems in developing a standard cellulase assay outlined by Ghose are also present when one considers β -galactomannans, β -glucomannans and β -mannanase assays. In fact, as heteropolysaccharides, β -mannans present a nightmare of end-products compared with a homopolymer such as cellulose. Furthermore, our knowledge of the structure of cellulases and celluloses that evolved as a result of the research of the 1970s and 1980s far outdistances our current rudimentary understanding of β -D-mannans and β -mannanases. Thus, developing a consensus regarding a standard β -mannanase assay will be an even greater challenge than Ghose and his colleagues faced.

Methods that have been used to measure the degradation of a variety of β -mannans include: 1) Monitoring changes in viscosity; 2) Gel filtration and/or thin layer chromatography followed by reducing sugar assays or by acid hydrolysis and HPLC analysis of the separated fractions; 3) Monitoring the release of dye from complexes of β -mannan and dyes such as Remazol Brilliant Blue-carob; and 4) Enzymatic assays based upon detection of hydrolysis using reducing sugar assays, such as the Nelson-Somogyi and DNS assays. Each of these techniques was considered for use during the study of *Trichoderma harzianum* β -mannanase.

1. Classification and detection of β -mannanase capable of degrading wood mannans.

The ability of reported enzymes to degrade vegetable β -D-mannans does not necessarily reflect their ability to degrade wood mannans. β -Mannanases from most of the organisms studied have not yet been evaluated using softwood mannans or pulps as substrates. The ambiguous nature of the terms mannan and β -mannanase make it difficult to identify from the literature those enzymes which would be capable of effective hydrolysis of wood mannans.

Detection and quantification of β -D-mannanase activity in crude enzyme preparations using wood as an assay or growth substrate is impractical for several reasons. For example, insoluble substrates such as whole wood, sawdust, and pulps are difficult to separate from growing fungi and absorbed/adsorbed proteins which may have enzymatic activity. Furthermore, interpretation of data from wood based assays for β -mannanase activity is further complicated by the heterogenous nature of both the substrate and the enzyme preparation. As previously mentioned, wood is a heterogenous matrix containing cellulose and xylan polymers as well as β -D-mannans. Culture filtrates from most organisms, especially those from microbes grown on wood substrates, and commercial enzyme preparations contain a variety of other polysaccharidases. These extraneous enzymes may degrade non-mannan components found in the wood thereby liberating a complex mixture of products which would be difficult to distinguish from the products of any β -mannanase activity that may or may not be present in the crude enzyme preparation. In addition, the random arrangement of glucose and mannose along the

backbone of softwood β -D-glucomannans and β -D-galactoglucomannans make quantitative and even qualitative evaluation of the activity and specificity of enzymes on wood mannans difficult. For example, softwood mannan has a backbone of mannose and glucose in a ratio of approximately 3 : 1 (Figure 3). Galactose is linked at irregular intervals by α -1,6 mannose bonds to the glucomannan backbone and since the backbone does not have a simple repeating unit, three or more mannopyranosyl or glucopyranosyl units may occur interstitially prior to the insertion of the other pyranosyl. Thus, the enzymatic hydrolysis of softwood mannan could result in at least six different trimers and an even greater number of tetramers. The heterogeneity of the monomeric and oligomeric components of random mannan breakdown and the variation in the relative amount of each component in the breakdown products of β -mannanase action, renders quantitative analysis of partial hydrolysis extremely difficult. This problem is further compounded with reducing sugar assays where mixtures of oligomers and dimers do not respond in a linear manner (Breuil and Saddler 1985).

Even if one were able to rationalize the above parameters for wood mannans as an assay substrate, the fact that the mode of wood mannan preparation could affect the nature of the substrate, not to mention the batch to batch variation, militates against its use. Therefore, because of the complexity of wood mannans and the heterogenous matrix of lignin, cellulose, and hemicellulose found in wood, there is a need to use other mannans as model substrates to initially detect and characterize mannanase activity. Model substrates such as locust bean gum β -D-galactomannan (Araujo and Ward 1990a; 1990b; 1990d; Rättö and Poutanen 1988; Talbot and Sygusch 1990), and konjac root powder β -D-glucomannan (Johnson 1990; Johnson *et al.*, 1990) have been used in the

detection, production, and characterization of enzymes assessed as candidates for use in the selective removal of mannans from wood pulps.

V. The Potential Applications of β -Mannanases

As mentioned previously, the potential of β -mannanases in biopulping applications (Clark *et al.*, 1988; Johnson *et al.*, 1990; Kantelinen *et al.*, 1988; Paice *et al.*, 1988), has renewed interest in these enzyme activities. Data regarding β -mannanases and possibly other wood degrading enzymes may also aid in the development of better wood preservation techniques. Highley (1987) believed hemicellulose degradation to be a critical step in the initial stages of wood deterioration and that blocking this process may arrest or significantly retard the decay process. The loss of wood and wood products caused by decay is estimated to cost more than 50 million (canadian) dollars per year. Fungal diseases have been identified as one of the main factors contributing to loss of forests and reducing the value of finished lumber products. For this reason, lumber manufacturers, foresters, and individuals interested in the preservation of wood products have an economic interest in the enzymatic hydrolysis of wood by microorganisms and macro-fungi. The extent of the decay problem is demonstrated by estimates that mortality due to insects and fungal diseases of forests is almost 130 million cubic metres of wood per year. It has been calculated that even if only 8% of this loss could be prevented, an additional 1.45 billion dollars of forest products could be generated representing 400 million dollars in wages and salaries (Kendrick 1985). An improved understanding of degradative fungal enzymes may lead to more effective methods for rot control and subsequent reductions in the economic losses of the forest products industry.

The potential use of a β -mannanase, or complexes of mannanases may not be limited to the forest products industry in that β -mannans occur as undesired components in agricultural wastes, inks, chicken feed, and coffee extracts (Boopathy 1987; Ehlers 1980; McCleary 1986; Wilke 1979). A suggestion that β -mannanases be used as a clarification agent for fruit juices and wines has been forwarded (Dekker 1979; Firantas *et al.*, 1983). Finally, on a more esoteric plane, selective enzymatic hydrolysis of mannose containing carbohydrates may be used to elucidate their location and structure within plant tissue. β -Mannans whose structures have been studied by analyzing the products of their enzymatic hydrolysis include guar gum (Heyne and Whistler 1948), carob or locust bean gum (McCleary 1979a), konjac flour (Smith and Srivastava 1959), coffee bean mannan (Wolf from *et al.*, 1961), ivory nut (Chanzy and Dube 1979), and softwood mannan (Boutelje and Hollmark 1972; Hoffman and Parameswaran 1976; Sinner *et al.*, 1976; 1979).

An understanding of the physicochemical characteristics and the factors that affect β -mannanase production and activity are germane to the determination of its potential application. This dissertation summarizes work directed towards obtaining the information needed to assess the potential of *T. harzianum* E58 β -mannanase.

MATERIALS AND METHODS

I. Reagents

The source of each reagent is indicated within the description of the methodology where it is used. All chemicals used in the preparation of growth medium and assay reagents were A.C.S. certified grade. Where possible analytical grade compounds were employed in studies of enzyme effectors and inhibitors. Electrophoresis and chromatography work was carried out using analytical or HPLC grade chemicals prepared in distilled deionized water (MillQ-Reagent Water System, Millipore Ltd.). Exceptions to the above statements are indicated in the text.

II. Fungal Culture Conditions and Inoculum

Cultures were obtained from the Forintek Canada Corp. culture collection. Cultures were grown on Mandels (Mandels *et al.*, 1976) medium agar containing 1% (w/v) mannose, for 4 days at 28°C or 44°C. All cultures were maintained on agar slants containing 2% (w/v) mannose, 1% (w/v) yeast extract and 1% (w/v) peptone agar.

For β -D-mannanase (EC 3.2.1.78) production studies using *Trichoderma harzianum* E58, a mycelial suspension of the fungus was inoculated into 500 mL baffled flasks containing 250 mL of Mandels medium (Mandels *et al.*, 1976) supplemented with 2% (w/v) mannose. Following 4 days of incubation in a gyratory shaker operated at 100 rpm and 28°C, the culture was centrifuged (3800 x g, 30 min) and washed twice with 100 mL of Mandels medium. This cell preparation was used as the source inoculum for production studies (2% v/v).

III. Polysaccharide Preparation and Analysis

A. *Substrate preparation.*

1. *Celluloses.*

Avicel PH101 (Fluka AG, Switzerland), solka floc AS1040 (Brown and Co., NH, USA), carboxymethyl cellulose (CMC); Sigma Chem Co., medium viscosity, DP 1100, DS 0.7) were used without further preparation.

2. *Xylans.*

Oat spelts xylan (lot # 87F-0349, Sigma Chem Co., St. Louis, Mo, USA) and larchwood xylan (lot #113F-003, Sigma Chem Co., St.Louis, Mo, USA) were used without further preparation. Birch and aspen xylans were gifts from Dr. K.G. Johnson (NRC Canada, Ottawa). The sample of *Pinus radiata* xylan was a gift from Dr. Tom Clark (Forest Research Institute, New Zealand).

3. *Wood and wood derivatives.*

a) *Wood sawdust.*

Black spruce sawdust samples were supplied by Dr. H.H. Brownell (Forintek Canada Corp.). The black spruce samples had been ball-milled (3 weeks, 20 -40 mesh) and then solvent extracted with 1 part ethanol to 2 parts benzene. The sample of *Pinus radiata* sawdust was a gift from Dr. Tom Clark (Forest Research Institute, New Zealand).

b) Black spruce lignin carbohydrate complex.

Black spruce lignin carbohydrate complex (LCC) was a gift from Dr. Brownell (Forintek Canada Corp.). The LCC had been extracted from a sample of the black spruce sawdust by liquid-liquid partitioning (Brownell 1970) and contained 56.7% Klason lignin and 43.5 % carbohydrate.

c) Spruce wood water-solubles.

Spruce water-soluble extracts (SWS) were obtained from white spruce wood chips using the steam treatment methods described by Brownell and Saddler (1984). In this process, 350 g of wood chips were steamed for 70, 90, 120, 160 and 180 seconds at 240°C followed by explosive decompression. The material from each treatment time was stirred in a 5% (w/v) slurry of distilled water. The slurry was washed twice with 10 L of deionized distilled water under vacuum at room temperature. The resulting filtrates were combined and were concentrated 10-fold by rotary evaporation prior to lyophilization. The lyophilized extract from each treatment was stored at -20° C until needed.

4. Mannans.

a) Growth medium supplements.

Locust bean gum (lot #37F-0186) was purchased from Sigma (St. Louis, Mo, USA). Konjac root powder was purchased from a local market. Two percent (w/v) slurries of each mannan were prepared by slow addition to distilled water at 80°C. The slurries were blended in a Waring blender and centrifuged for 20 min at 2200 x g to

remove suspended particles. Mannans used as growth substrates were prepared immediately prior to use.

b) Assay substrates.

Yeast cell wall α -mannan from *Saccharomyces cerevisiae* was purchased from Sigma (St. Louis, Mo USA). High viscosity grade guar gum was purchased from Serva (Heidelberg, Germany). β -D-Mannans used for enzyme assays were prepared from konjac root powder, locust bean gum, and guar gum according to the method of Dea *et al.*, (1977). The mannan powders were washed with 50% ethanol and the residues were resuspended in distilled water. The resultant solutions were then lyophilized. Solubilized locust bean gum was prepared by limited cellulase pre-treatment according to the method described by McCleary (1988d). Pine glucomannan, a gift from Dr. Tom Clark (Forest Research Institute, New Zealand), had been extracted from *Pinus radiata* and was used without further modification. Deacetylated konjac glucomannan was prepared by alkali treatment (0.2 M NaOH) of assay grade konjac glucomannan according to the procedure of Biely *et al.*, (1986). To prevent contamination, 0.02% (w/v) azide was added to all reconstituted substrates used in enzyme assays. Rehydrated substrates were stored at 4°C.

B. Analysis of polysaccharides used as media supplements.

The composition of the polysaccharide used to supplement growth medium was determined following the acid hydrolysis Klason procedure (TAPPI Standard method T222 os-74, 1989). The acidic hydrolysates were analyzed by high performance liquid chromatography (HPLC) as described in Analytical Methods, Section D. Samples

requiring neutralization prior to HPLC separation using a BioRad HPX87P column were titrated with saturated barium hydroxide. The insoluble barium hydroxide precipitate was removed by centrifugation and the resultant supernatant fractions concentrated 10-fold by rotary evaporation. In each case, erythritol was used as an internal standard.

IV. Analytical Methods and Experimental Techniques

A. Quantitative chromogenic techniques.

Protein concentration was estimated using the Bio-Rad protein microassay procedure (Bio-Rad Laboratories, Richmond, CA) which is based on the Bradford method (Bradford, 1976). Bovine serum albumin was used as the assay standard.

Total carbohydrate content was measured by the phenol sulfuric acid assay using glucose and mannose as the standard (Dubois *et al.*, 1956).

Reducing sugars were determined by either the 3,5 - dinitrosalicylic acid (DNS) assay method (Miller 1959) or the Nelson-Somogyi method with the appropriate monomer as the standard (Somogyi 1952). The DNS assay was used to monitor enzyme activity eluted from columns during enzyme purification. In all other procedures, reducing sugars were measured by the Nelson-Somogyi method. After the samples had been boiled for 15 minutes and the assay reagents added, samples were centrifuged for 5 minutes in a microcentrifuge to remove the unhydrolyzed substrates. The optical density of the sample was determined at 500 nm and sample dilutions with optical densities ranging from 0.200 to 0.900 were used to quantify the reducing sugars present in the sample. Duplicates of each sample were analyzed and the amount of reducing sugar present in each sample was

calculated from standard curves prepared using mannose, glucose, and xylose as standards.

B. Enzyme assays.

β -D-Galactomannanase and β -D-glucomannanase activities (EC 3.2.1.78) were estimated using β -D-mannans prepared from locust bean gum and konjac root powder respectively. Unless otherwise specified, reaction mixtures containing 50 mM sodium acetate buffer, pH 4.8, appropriate enzyme dilutions, and 2.5 mg of β -D-mannan substrate in a total volume of 1.0 mL were prepared. The enzyme reaction was initiated by the addition of 0.5 mL of an appropriate dilution of the enzyme to the aqueous substrate pre-warmed at 50°C for 5 minutes. Following 30 minutes incubation at 50°C, the reaction was terminated by the addition of Nelson-Somogyi copper reagent and the amount of reducing sugars liberated was estimated by the Nelson-Somogyi method as previously described. The activity of the enzyme towards pine glucomannan, solubilized locust bean gum, guar gum, deacetylated konjac glucomannan, and yeast cell wall α -mannan was also estimated by the above method. For all mannans, one unit of activity was defined as the amount of enzyme catalyzing the release of 1 μ mol of mannose equivalent per minute at pH 4.8 and 50°C.

Endoglucanase activity (EC 3.2.1.4), was determined as described for β -D-mannanase activity except that carboxymethyl cellulose served as the assay substrate. One unit of endoglucanase activity was defined as the amount of enzyme catalyzing the release of 1 μ mole of glucose equivalent per minute at pH 4.8 and 50°C.

Xylanase activity (EC 3.2.1.8), was estimated with the aforementioned xylan substrates in reaction mixtures prepared as for the measurement of β -D-mannanases with the following exceptions. After incubation at 50°C, reaction mixtures were immediately boiled for 10 minutes and then cooled in an ice-water bath. Cooled samples were centrifuged to sediment insoluble xylan and denatured protein. The resultant supernatant fractions were assayed for their content of reducing sugars using the Nelson-Somogyi method. One unit of activity was defined as the amount of enzyme catalyzing the release of 1 μ mole of xylose equivalent per minute at pH 4.8 and 50°C.

The ability of the enzyme to release reducing sugars from insoluble celluloses was determined as for xylanase activity except that Avicel and solka floc were employed as assay substrates and one unit of activity was defined as the amount of enzyme catalyzing the release of 1 μ mole of glucose equivalent per minute at pH 4.8 and 50°C.

α -Galactosidase (EC 3.2.1.22), activity was estimated using *p*-nitrophenyl- α -galactopyranoside (Sigma, St Louis, Mo) as the substrate. Reaction mixtures contained 50 mM sodium acetate buffer, pH 4.8, appropriate enzyme dilutions, and 2 mg of substrate in a total volume of 1.0 mL. After the reaction was initiated by the addition of 0.5 mL dilute enzyme to the aqueous substrate pre-warmed at 50°C for 5 minutes, the reaction mixtures were incubated at 50°C for 30 minutes. The reactions were terminated by the addition of 1 mL of 10 % (w/v) Na₂CO₃ and the absorbance at 410 nm was measured. One unit of enzyme activity was defined as the amount of enzyme catalyzing the release of 1 μ mole of *p*-nitrophenol per minute at pH 4.8 and 50° C.

β -Xylosidase (EC 3.2.1.37), β -mannosidase (EC 3.2.1.25), and β -glucopyranosidase (EC 3.2.1.21) activities were measured as above using the

corresponding *p*-nitrophenyl substrates (Sigma, St. Louis, Mo). One unit of enzyme activity was defined as the amount of enzyme catalyzing the released of 1 μ mole of *p*-nitrophenol per minute at pH 4.8 and 50° C.

Protease activity was estimated using the Azocoll (Calbiochem Corp. San Diego, Calif) method. One mL of sample was incubated with 1 mL of 50 mM buffer (final concentration) at the desired pH containing 5 mg of Azocoll. Following 30 minutes at 37°C, reactions were terminated by removing the unhydrolyzed insoluble substrate by filtration of the reaction mixture through a Pasteur pipette plugged with glass wool. The absorbance of the filtrate at 520 nm was determined from a standard curve relating the concentration of the solubilized Azocoll to the absorbance at 520 nm. One unit of activity was defined as the amount of enzyme catalyzing the solubilization of 1 mg of Azocoll per minute at 37°C.

C. Isoelectric focusing and zymogram techniques.

1. Isoelectric focusing (IEF).

Samples of enzyme preparations were loaded onto pre-cast IEF minigels prefocused to provide a pH gradient of 3 to 10 (Pharmacia Ltd., Sweden), using a 1 μ L sample applicator. Isoelectric focusing was accomplished using a Pharmacia PhastSystem electrophoresis apparatus which generate a total of 500 Vh during each 45 minute run. Duplicate gels were run simultaneously. One gel was used for zymogram analysis (*vide infra*) while the second was immediately stained to locate protein bands. Protein bands were detected by silver staining, (Blum *et al.*, 1987; Heukeshoven and Dernick 1985), using the Pharmacia Silver Stain Kit. The isoelectric points (pI values) of the protein

bands were determined by comparison with protein standards of known isoelectric points.

2. Zymogram analysis.

Outlines of PhastSystem gels were traced onto the hydrophobic side of Gel-Bond film (FMC Corp., Switzerland). The film was placed in a LKB gel casting mold with a 0.3 mm spacer. Molten (44.5°C), degassed agar (2% w/v) in 50 mM sodium acetate buffer (pH 4.8) containing 0.5% (w/v) of the assay substrate, was poured onto the hydrophilic side of the gel. A second film was placed, the hydrophobic side down, onto the agar and a glass plate was placed on top of the films. Once the substrate agar had solidified, the individual tracings of the gels were cut out of the film-substrate agar-film sandwiches.

An IEF gel containing the focused proteins was gently washed with 50 mM sodium acetate buffer (pH 4.8), the top film removed from the agar substrate and the IEF gel overlaid on the agar substrate film. To maintain a moist environment during incubation of the zymogram, the IEF gel and the substrate agar film were incubated (30 minutes, 50°C) in sealed petri plates on top of water-saturated filter paper.

After incubation, the IEF gel was removed from the agar and stained for protein. The substrate agar was flooded with a 0.1% (w/v) Congo red solution. To ensure uniform staining, the petri plates were shaken gently at 25°C and 80 rpm for 30 minutes after which the excess dye was drained from the plates. Unbound dye was eluted with 1 M NaCl and the bound dye was fixed by washing the agar with 5% (v/v) acetic acid. Zones of enzyme activity appeared as cleared areas upon a red background. The stained

agar was compared with the silver stained IEF gel and the pI values of proteins causing clearing zones on the agar were noted.

In separate zymogram experiments, mannose (1 % w/v) was added to β -D-mannan substrate agar to assess the effect of mannose on the β -D-mannanase activity of the focused proteins of each culture filtrate. The zymogram profiles obtained were compared with the zymogram profiles obtained from substrate agar to which no mannose had been added. Similarly, the effect of SWS (spruce wood water-solubles) on β -D-mannanase activity was assessed by incorporating SWS from 180 second steam treated spruce wood into the zymogram agar .

D. Chromatographic techniques.

1. Thin layer chromatography (TLC) analysis.

Thin layer chromatography of enzyme-treated and untreated substrates was performed with a solvent mixture of n-butanol:pyridine: distilled water, (6:4:3 v/v/v), according to the method of Kusakabe *et al.*, (1983). Samples were spotted onto glass plates coated with a 0.5 mm layer of silica gel (Merck Inc., Germany). Resolved carbohydrates and hydrolysis products were detected using a ceric sulphate detection reagent developed by John Labelle (NRC Canada, Ottawa). The reagent contained 1 g ceric sulphate, 0.25 g ammonium molybdate, 10 mL concentrated sulfuric acid, and 90 mL distilled water. After spraying with this reagent, plates were heated at 80°C. Carbohydrate containing materials appeared as purple spots on an off-white background. Resolved spots were compared with the migration of monomers and small molecular weight oligomers. β -Mannobiose, β -mannotriose, and β -mannotetrose standards were a

generous gift from Dr. Isao Kusakabe (University of Tsukuba, Ibaraki, Japan) and had been purified from copra mannan hydrolyzed by *Streptomyces* spp. enzymes (Kusakabe *et al.*, 1983).

2. High performance liquid chromatography (HPLC).

Chromatographic separations of polysaccharide constituents were performed using a Waters 712 WISP system HPLC interfaced with a Digital Pro350 microcomputer. Two column systems were employed. The BioRad HPX 87H column, which separates acidic solutions was operated at 70°C using a flow rate 0.6 mL/min with 0.01 N H₂SO₄ as the eluant.

For the resolution of mannose and xylose, as well as small manno-oligomers, a BioRad HPX 87P column linked to a BioRad HPX 42A column was employed. Samples were fractionated on this system at 70°C using a flow rate 0.6 mL/min with deionized distilled water as eluant.

All samples were filtered through 0.45 μm HV pre-filters (Millipore Ltd.) before loading onto the columns. Relative amounts of each sugar component was determined by automatic integration using an erythritol standard.

3. Ion exchange chromatography.

All ion exchange columns were run under gravity. Samples were applied to the columns in a solution of the starting buffer used for column equilibration.

a) Cation exchange chromatography

Cation exchange chromatography was performed with 15 mL columns of CM-Sepharose pre-swollen gel (Pharmacia, Uppsala, Sweden) equilibrated with 10 mM sodium acetate buffer. To determine if β -D-mannanase activity was absorbed to this cation exchange resin, buffered samples were applied to columns equilibrated with sodium acetate buffer at the following pH values : 3.7, 4.0, 4.4, 4.8, and 5.5. Following sample application, columns were washed with three column bed volumes of the appropriate buffer and the protein content of the effluent was estimated by monitoring the absorbance at 280 nm. The β -D-galactomannanase activity of eluant was monitored by the DNS assay as described earlier.

b) Anion exchange chromatography

Anion exchange chromatography was performed with pre-swollen DEAE-Sepharose gels (Pharmacia, Uppsala, Sweden).

i) Selection of preparative anion exchange conditions.

For determination of the optimal conditions for preparative anion exchange, 15 mL columns of DEAE-Sepharose were equilibrated with 10 mM Tris-HCl buffer at pH values of 7.0, 7.45, 8.1, 8.6, or 9.1. Following sample application, the columns were washed with three column bed volumes of the appropriate buffer and the protein content of the effluent estimated by monitoring the absorbance at 280 nm. The β -D-galactomannanase activity of the eluant was monitored by the DNS assay as described earlier.

For determination of the optimal salt concentration for elution of β -D-mannanase active protein absorbed to DEAE-Sepharose at pH 8.6, a series of 15 mL columns were equilibrated with 10 mM Tris-HCl buffer of pH 8.6 containing 0, 0.001, 0.05, 0.1, and 0.3 M NaCl. Enzyme preparations were desalted by gel filtration (as described below in Section D part 4 - Gel Filtration), and then applied (0.05 mg protein/column) to the columns. Protein was eluted by washing the columns with the appropriate buffer solution and the absorbance of the effluent fractions (1 mL) at 280 nm was monitored. Protein containing fractions were assayed for β -D-galactomannanase activity.

ii) Preparative DEAE-Sepharose exchange chromatography.

Preparative DEAE-Sepharose exchange chromatography was performed with a 2.6 x 23 cm ($V_o = 33$ mL; $V_t = 115$ mL) column equilibrated with 10 mM Tris-HCl buffer, pH 8.6 containing 0.02% (w/v) sodium azide. Enzyme preparations were desalted by gel filtration, (as described below in Section D part 4 - Gel Filtration), and applied to the column via a sample reservoir. The column was washed with approximately three column bed volumes of starting buffer before a linear salt gradient from 0 - 0.35 M NaCl was applied to elute the protein bound to the ion exchange matrix. Effluent fractions (1.5 mL) were monitored for both their absorbance at 280 nm and enzyme activities.

4. Gel filtration.

a) Desalting and buffer exchange.

Where required, samples were desalted and buffer solutions exchanged by gel filtration using pre-packaged 10 mL columns of Bio-Gel P-6 (Econo-Pac 10DG, BioRad, Richmond, Calif.). Columns were equilibrated with the desired buffer, the sample (3 mL) loaded directly onto the column, and the protein content of the effluent fractions (1 mL) estimated by monitoring absorbance at 280 nm.

b) Gel filtration chromatography

A Sephadex G-100 (Pharmacia Corp., Sweden) gel filtration column was equilibrated with 10 mM potassium phosphate, pH 6.2 containing 0.02% azide. The column was calibrated for molecular weight determination using a standard mixture of; thyroglobulin, gamma globulin, ovalbumin, myoglobin, and vitamin B₁₂ (Bio-Rad, Richmond, Calif USA).

Gel filtration properties were expressed in terms of the distribution coefficient, K_{av} :

$$K_{av} = \frac{V_t - V_e}{V_t - V_o}$$

where V_t is the total volume of the column, V_e is the volume at which a particular component elutes, and V_o is the void volume of the column system. V_o and V_t were determined with the Dextran Blue 2000 (Pharmacia Corp., Sweden) and vitamin B₁₂ respectively.

V. Experimental Procedures

A. Screening protocols for fungal β -D-mannanase activity.

Microorganisms were grown on solid agar media containing yeast extract and Bacto-peptone to ensure that any required vitamins or cofactors necessary for enzyme production were present. The agar medium (YPLA) contained 1% (w/v) yeast extract, 2% (w/v) peptone, 1% (w/v) locust bean gum and 2% (w/v) Bacto-agar. Further growth experiments were carried out using liquid medium (YPLM) of similar composition. Fungi tested for their ability to produce β -D-mannanase included representative strains of two fungi known to be capable of mannan degradation, *Aspergillus niger* (Reese and Shibata 1965; Sinner *et al.*, 1976) and *Tyromyces palustris* (Shimizu and Ishihara 1983) as positive controls. Four yeasts, (*Candida wickerhamii* 689A, *Pichia wickerhamii* 689, *Pichia stipitis* CBS5776, *Pichia stipitis* CBS5876), and 3 other filamentous fungi (*Trichoderma harzianum* E58, *Thielavia sp.* CM1131014, and *Thermoascus aurantiacus* C436), known to excrete enzymes capable of hydrolyzing polysaccharides found *in vivo* to be associated with β -D-mannans, were examined. Mesophile slant cultures were incubated at room temperature. The two thermophiles, *Thielavia sp.* and *Thermoascus aurantiacus* were incubated at 44°C. All slants were stored at 4°C.

1. The ability to grow in β -D-mannan supplemented medium.

The ability to grow on solid agar in the presence of locust bean was determined using YPLA medium. YPLA medium was inoculated from slant cultures of the selected microorganisms and the plates were incubated at the appropriate temperature for 14 days. To determine if the locust bean gum in the medium was being hydrolyzed, fungi were

transferred to liquid media where substrate utilization could be more easily monitored. Microorganisms which showed visible growth in YPLA medium were transferred to 500 mL shake flasks (150 rpm) containing 200 mL of YPLM medium and were incubated for an additional 2 weeks. Ten mL samples were withdrawn aseptically every 3 days, the fungi removed by filtration through glass microfibre filters (Whatman 934AH glass microfibre paper), and the locust bean remaining in the filtrate was estimated as described below.

2. The ability to utilize β -D-mannan.

Utilization of locust bean gum was estimated by measuring both the total carbohydrate and the reducing sugars present in filtrates from two week old cultures using the phenol sulfuric acid and Nelson-Somogyi techniques respectively. The total carbohydrate utilized was expressed as a percent of the total sugar found in the uninoculated medium. The average relative degree of polymerization (DP) of each culture filtrate was calculated by dividing the total carbohydrate remaining by the reducing sugars equivalents detected, as described by Emi and his coworkers (1972). The culture filtrates of fungi that utilized more than 10% of the locust bean in the medium were then assayed for the presence of β -D-mannanase activity as follows.

3. The ability of culture filtrates to solubilize β -D-mannan on solid medium.

The ability of fungi culture filtrates to solubilize locust bean gum and konjac root powder in solid medium was determined by a Congo red agar assay. Eight mm glass microfibre disks (Whatman 934AH glass microfibre paper) were soaked in a sample of

culture filtrate and placed on agar containing the β -D-mannan substrate of interest. The agar plates were sealed with parafilm and incubated at 50° C for 30 min. Disks were then removed from the plates and the plates were flooded with 0.1% (w/v) Congo red dye. To allow the dye to react with the substrate and ensure that staining was uniform, the plates were incubated at room temperature for 30 minutes with gentle shaking (80 rpm). Excess stain was then drained from the plates and the agar plates destained with three successive washes of 1M NaCl. Areas where Congo red failed to bind appeared as clear zones on a red background and indicated the ability of the filtrate fraction to solubilize the mannan. Areas where the agar was partially decolorized by the NaCl were recorded as partial solubilization. A lack of a clearing zone where the disk had been placed was interpreted as a lack of the ability of the test culture filtrate to solubilize β -D-mannan.

B. Production and identification of *T. harzianum* E58 β -D-mannan-degrading enzymes.

1. Production of β -D-mannanase activity by *Trichoderma harzianum* E58 grown on different polysaccharide medium.

To determine if β -D-mannanase activity was present when *T. harzianum* was grown on non-mannan polysaccharides, activity was assessed during growth on different substrates. Enzyme production studies were carried out using modified Mandels' medium lacking peptone. This medium was supplemented with the vitamin complement of Vogel's medium (Montenecourt and Eveleigh 1977) and contained 1% (w/v) of either Avicel, SWS, oat spelts xylan, locust bean gum or konjac root powder glucomannan.

For each substrate studied, three 2 L baffled flasks containing 600 mL of medium were inoculated with 1 mL of the washed cell suspension described earlier, (Section II). The cultures were grown for 12 to 15 days at 28°C on a gyratory shaker operated at 150 rpm. Every 24 - 48 hours, 20 mL samples were aseptically removed and filtered through Whatman 934AH glass microfibre paper. After recording the pH, 0.01% (w/v) sodium azide was added to prevent contamination and the crude filtrates were stored at 4°C.

The ability of each culture filtrate to solubilize both konjac root powder β -D-glucomannan and locust bean gum β -D-galactomannan was determined by the previously described Congo red agar assay. All culture filtrates were analyzed by IEF followed by β -D-galactomannanase and β -D-glucomannanase zymogram analyses. The β -D-galactomannanase and endoglucanase activity of each culture filtrate was measured by the Nelson-Somogyi method using the appropriate monomer as the assay standard. The reducing sugar equivalents present, in the uninoculated media and in the culture filtrates to which assay substrate had not been added, were determined for each sample. These background levels of reducing sugar were subtracted from the calculated enzyme activities.

When β -D-galactomannanase activity was maximal (units/ml culture filtrate), culture filtrates were analyzed with respect to protein content, β -D-glucomannanase activity, IEF protein banding patterns, and zymogram profiles using CMC as well as the β -D-mannan substrates. At the same time, the effect of 1% (w/v) mannose on the IEF galactomannanase zymogram profiles of each filtrate was examined in separate studies.

2. Production of β -D-mannanase activity in the presence of mannose.

To study the effect of mannose on β -D-mannanase production, media containing 0.5% and 1.0% (w/v) locust bean gum were supplemented with 0.5% and 1.0% (w/v) mannose prior to inoculation. Medium containing mannose, but not locust bean gum, was also prepared. Cultures were grown and sampled as described in the previous procedure. These samples were examined for β -D-galactomannanase activity, pH, protein, and mannose content. IEF protein bands and zymogram patterns of culture filtrates after 6 - 8 days growth were determined as described previously.

C. Isolation of the extracellular β -D-mannanase activity from *T. harzianum* E58.

At each step in the isolation of β -D-mannanase activity, the amount of β -mannobiase, α -galactosidase, β -glucosidase, β -xylobiase, endoglucanase, α -mannanase, β -glucomannanase, β -galactomannanase, and protease activity, as well as total protein, was measured. The ability of the enzyme preparation to hydrolyze Avicel, oat spelts xylan, larchwood xylan, guar gum, and pine glucomannan was also measured.

STEP 1. Production and concentration of culture filtrate containing β -D-mannanase activity.

A total of 14 L of 6 day old *Trichoderma harzianum* E58 culture, grown in seven 4 L flasks each containing 2 L of modified Mandels' medium supplemented with 1.0 % (w/v) locust bean gum was filtered through Whatman 934AH glass microfibre paper under reduced pressure. The resultant culture filtrate was concentrated by ultrafiltration using a Pellicon ultrafiltration cell (Millipore Corp. Bedford, Mass.) equipped with 10

Kd membranes and was further concentrated in an Amicon (Danvers, Mass.) ultrafiltration cell equipped with a YM - 10 membrane. The Amicon retentate was desalted and stored at 4°C, after the addition of 0.02% (w/v) sodium azide.

STEP 2. Fractionation of the Amicon retentate by preparative anion exchange on DEAE-Sepharose.

Anion exchange chromatography was performed as described in Section 4 (iii). Forty-seven mL (approximately 50 mg of protein) of ultra-retentate was loaded onto the column. After the column was washed with buffer a salt gradient was applied. The salt gradient was generated using a Pharmacia GM1 gradient mixer (Pharmacia, Sweden) containing 200 mL of eluant buffer and 200 mL buffer containing 800 mM NaCl in the same buffer. The pH of the eluted fractions was adjusted to pH 5-6 using 2.5 μ L dilute glacial acetic acid per mL. Effluent fractions were monitored for β -mannobiase, α -galactosidase, endoglucanase, β -D-glucomannanase, β -D-galactomannanase, and xylanase activities as previously described (Section B) using 1:50 dilutions of selected fractions. The spectrometer was zeroed with a substrate blank and enzyme activities were expressed relative to the reducing sugars detected in untreated assay substrates. Fractions possessing a relative mannanase activity greater than 1.0 were examined by IEF and β -D-galactomannan and β -D-glucomannan zymograms. Fractions of individual peaks with relative enzyme activities greater than 1.0 were pooled and 0.02% (w/v) sodium azide added.

STEP 3. Gel filtration of pooled β -D-mannanase from anion exchange chromatography.

Pooled β -D-mannanase fractions were concentrated in an Amicon (Danvers, Mass.) ultrafiltration cell equipped with a YM - 2 membrane. The Amicon retentate was desalted and the buffer exchanged for 10 mM potassium phosphate, pH 6.2. Ten mL of this concentrate was applied to a column of Sephadex G-100 as described in Section D2. Eluent fractions were monitored for β -D-glucomannanase, β -D-galactomannanase, and endoglucanase activity using the DNS assay. Fractions possessing a relative mannanase activity greater than 1.0 were pooled after examination by IEF and the β -D-galactomannan zymogram techniques.

D. Enzyme properties of the β -D-mannanase isolated from *T. harzianum* E58 culture filtrate.

1. Molecular weight determination.

The molecular weight of the purified β -D-mannanase was determined by sodium dodecyl sulfate (SDS) gel analysis using Pharmacia's PhastSystem electrophoresis apparatus and 10/15 pre-cast native gradient PAGE gels. Proteins were detected by the Pharmacia silver staining kit for protein analysis. A second SDS gel electrophoresis using the larger pre-cast Mini-PROTEAN II Ready-Gel and apparatus (Bio-Rad, Richmond Calif.), was also employed. In the latter system, homogenous 12% pre-cast PAGE gels (0.5% (w/v) SDS), were used with Tris-HCl running buffer at pH 8.3. Protein (10 μ g) was electrophoresed at 200 V and 2.0 amps. Proteins were detected by staining with a solution of 0.25 % (w/v) Coomassie blue R-250, 40% (w/v) methanol,

and 30% (w/v) acetic acid, followed by washing with a solution of 40% (w/v) methanol and 30% (w/v) acetic acid. A molecular weight standards kit (Pharmacia, Sweden) containing rabbit muscle phosphorylase b (94, 000 mwt.), bovine serum albumin (67,000 mwt.), egg white ovalbumin (43,000 mwt.), bovine carbonic anhydrase (30, 000 mwt.), soya bean trypsin inhibitor (20,100 mwt.), and bovine milk α -lactalbumin (14,400 mwt.) was used for calibration.

2. Substrate hydrolysis.

The dilution of the purified *T. harzianum* β -D-mannanase releasing 0.05 mg of reducing sugar equivalents per mL from locust bean gum galactomannan under standard assay conditions was determined. Unless otherwise specified, all subsequent studies on the hydrolysis of β -D-mannans were carried out using this enzyme dilution. Specific activity was defined as the number of enzyme units per mg protein. The specific activity of the enzyme on the β -D-mannans substrates from guar gum, locust bean gum, konjac root powder, and pine glucomannan were determined by the β -D-mannanase activity assay.

a) The effect of incubation time.

A series of enzyme substrate mixtures containing 0.5 mL of diluted enzyme and 0.5 mL of 1.0 % (w/v) substrate were incubated at 50 ° C. After 0, 5, 10, 15, 30, 45 minutes and 1, 2, 4, 6, 8 hours, duplicate reaction mixtures were removed and the reaction terminated by rapid cooling in an ice waterbath. Fifty μ L of each reaction mixture were spotted onto TLC plates and the components separated and detected by the

TLC technique described. After the indicated incubation periods, the amount of reducing sugars present in each reaction mixture was determined by the Nelson-Somogyi method. A set of substrate and enzyme controls were co-incubated with test samples. The procedure was carried out using locust bean gum β -D-galactomannan and konjac root powder β -D-glucomannan as assay substrates.

b) The degree of β -D-mannan hydrolysis.

The products of the hydrolysis of the four β -D-mannans were detected by TLC analysis. One percent (w/v) of each mannan was incubated for 20 hours at 40 °C with 0.1 units of glucomannanase activity. The reaction was terminated by boiling for 10 minutes followed by rapid cooling in an ice-water bath. The cooled samples were then applied to TLC plates. The resolved hydrolysates of each β -D-mannan were compared with untreated samples, monomers, and small molecular weight oligomers. The increase in reducing sugar equivalents in enzyme substrate mixtures after incubation was measured by the Nelson-Somogyi method.

c) Hydrolysis of manno-oligomers.

Microcentrifuge tubes containing equal 40 μ L volumes of dilute enzyme and 1% (w/v) of oligomer were incubated for 30 minutes at 50°C. The reaction was terminated by boiling for 10 minutes followed by rapid cooling in an ice-water bath. Cooled samples were then applied to TLC plates for analysis. The resolution of the enzyme-treated reaction mixtures was compared with untreated mixtures, monomers and small molecular weight oligomers.

d) Kinetic parameters.

Serial dilutions from 0.001 to 1.0 % (w/v) of each test substrate were prepared in duplicate and pre-incubated for 5 minutes at 50° C. To 0.5 mL of each dilution in the series, 0.5 mL of dilute enzyme was added and the reaction mixtures incubated at 50°C for 30 minutes. A second set of substrate dilutions were incubated with 0.5 mL of buffer without enzyme to determine the background level of reducing sugars for each dilution in the series. This procedure was repeated for each of the four β -D-mannans substrates, as well as for deacetylated konjac root powder β -D-glucomannan. K_m and V_{max} values were obtained from the linear portion of Lineweaver-Burk plots of the data for substrate concentrations within approximately 0.2 - 2 K_m . The physiological co-efficient (V_{max} / K_m) and its value relative to that obtained for locust bean gum galactomannan were calculated from the K_m and V_{max} values obtained.

3. Optimum temperature.

Optimal temperature was determined by measuring β -D-mannanase activity on all four β -D-mannan substrates according to the described β -mannanase assay except that incubation of the reaction mixtures was carried out at 25°, 35°, 45°, 50°, 55°, 60°, 65°, 70°, and 75°C.

4. Thermostability.

The thermostability of the enzyme was assessed at 50°, 55°, 60°, 65°, 70°, and 75°C. Enzyme dilutions were incubated at each temperature for 0, 5, 10, 15, 20, 30, 45, 60, 90, 120, and 180 minutes, and were then rapidly immersed in an ice- water bath.

Cooled samples were evaluated for β -D-galactomannanase and β -D-glucomannanase activity as previously described. For each sample, the specific activity was calculated and compared with the specific activity of untreated enzyme. The specific activity of untreated enzyme was arbitrarily set to 100 and the activity of heat-treated enzyme was expressed relative to this value.

5. The influence of pH on activity.

The influence of pH on enzyme activity was determined using 25 mM buffer solutions at pH 3.5, 4.0, 4.4, 4.8, 5.6, 6.0 with sodium acetate buffer; pH 5.8, 6.2, 6.8, 7.5, 8.0 with potassium phosphate buffer; and pH 7.1, 7.5, 8.0, 8.5, 8.9 with TrisHCl. β,β -Dimethyl glutaric acid was also used to buffer the reaction mixture over the pH range 3.6 - 7.4. The assay substrate (1.0 % w/v) was prepared at each pH value in 50 mM of buffer. One half mL of dilute enzyme, prepared in distilled water, was incubated with 0.5 mL of substrate and the assay for β -D-galactomannanase and β -D-glucomannanase performed. The effect of the buffer and/or pH on the assay method itself was determined by measuring the response of the assay to 0.05, 0.025 and 0.01 mg mannose/assay solution at each pH value. The response was compared with the value obtained under normal assay conditions and a correction factor calculated. The specific activity of the enzyme within each reaction mixture was calculated and corrected for the effect of the pH and/or buffer on the Nelson-Somogyi assay itself. Using the procedures outlined above, the impact of pH 3.5, 4.8, 5.8, 7.1, 8.0, and 8.9, on the enzymatic degradation of pine glucomannan and guar gum were also assessed.

E. Affectors of enzyme activity.

1. Proteases.

To determine the effect of proteases on enzyme activity, 10 μg of enzyme was pre-treated with 50 μg each of either pepsin (EC 3.4.23.1), trypsin (EC 3.4.21.4), protease K (EC 3.4.21.14, from *Tritirachium album*), α -chymotrypsin (EC 3.4.21.1), or *Staphylococcus aureus* protease XVII-B (EC 3.4.21.19). All proteases were purchased from Sigma (St. Louis, MO.). All enzyme-protease mixtures were pre-incubated at 37° C in 10 mM potassium phosphate buffer at pH 7.5 except for enzyme-pepsin mixtures which were incubated in 10 mM sodium acetate at pH 3.5. After 30 minutes incubation, the total protein, β -glucomananase activity, and β -galactomannanase activity of the reaction mixtures was measured and compared with untreated enzyme samples. For each protease treatment, the remaining enzyme activity relative to enzyme activity incubated without protease (units/mg enzyme in pre-incubation reaction) was calculated. The specific activity was calculated as units of enzyme activity obtained after treatment divided by the amount of protein remaining after treatment. This value was expressed relative to the specific activity of enzyme that had been pre-incubated in the absence of protease. For each treatment, both the relative activity and the relative specific activity measured for β -glucomananase and β -galactomannanase were calculated.

2. Metal ions.

The effect of metal ions, and EDTA on activity was determined after diluted enzyme was pre-incubated for 15- 20 minutes with each of the potential affectors prior to the addition of the assay substrate.

The influence of metals upon the activity of the β -mannanase was assessed using serial dilutions of their chloride salts across a concentration range of 0 - 100 mM. Sodium chloride was also assessed at concentrations up to and including 500 mM. The effect of the metal ion on the assay method itself was determined by measuring the response of the assay to 0.05 mg mannose in solutions containing 0-100 mM of each metal salt. This response was compared with the value obtained under normal assay conditions and a correction factor calculated. The specific activity of the enzyme within each reaction mixture was calculated and corrected for the effect of the metal ion on the Nelson-Somogyi assay. Activity was expressed relative to the activity of enzyme assayed without the addition of any metal ions. The influence of 0.5 - 20 mM EDTA , a metal ion chelating agent, on the β -galactomannanase and β -glucomannanase activity of the enzyme was also assessed using the methodology outlined above.

3. Detergents and solvents.

The effects of detergents and solvents upon the activity of the enzyme were determined in the same manner as described for the metal ion studies. The impact of the addition of 0 - 2 % (v/v) Tween 80, Triton X-100, SDS (Sigma Chem Co., St Louis, Mo), Zwitterion TM314, and Phemerol chloride (Calbiochem Corp., San Deigo, Calif.) upon β -D-mannan hydrolysis was assessed by measuring the amount of enzymatically released reducing groups. Similarly, the influence of 1 - 20 % (v/v) methanol and ethanol on β -D-glucomannanase and β -D-galactomannanase activity was measured and expressed relative to the activity measured without the addition of solvent.

F. Interaction with non-target polysaccharides.

1. Enzyme activity in the presence of non-target substrates.

The activity of the enzyme towards celluloses, xylans and wood derivatives was measured by the Nelson-Somogyi assay. Substrates (25 mg) were incubated with 0.1 units of β -D-glucomannanase activity for 20 hours at 40 ° C and the amount of reducing sugar equivalents released was measured. The treated substrates were also analyzed by TLC and the migration of the resolved components compared with untreated samples as well as with that of monomers and low molecular weight oligomers.

In separate experiments, β -D-galactomannanase and β -D-glucomannanase activities of the enzyme were measured under standard β -mannanase assay conditions in the presence of 0.1, 0.2, 0.5 % (w/v) of either Avicel PH101, CMC, solka floc, larch xylan, birch xylan, or aspen xylan. Similarly, the impact of the addition of 0.1 and 0.2 % (w/v) pine xylan upon the ability of the enzyme to hydrolyze pine glucomannan was measured by the Nelson-Somogyi assay.

2. Association with celluloses and xylans.

The possible association of the β -D-mannanase with the "non-target" polysaccharides, Avicel PH101, solka floc, larch xylan, birch xylan, and aspen xylan was explored. Three units of β -D-galactomannanase activity were incubated with 1.0, 0.5, 0.2 % (w/v) of Avicel in 1.5 mL of 25 mM sodium acetate buffer at 30° C and pH 4.8 in a microcentrifuge tube. The mixture was agitated every 10 minutes. After 30 minutes, reaction mixtures were centrifuged for 5 minutes, the supernatant fraction decanted, the insoluble Avicel resuspended in buffer and washed twice with buffer. The β -D-

galactomannanase activity was determined for the supernatant fraction, both the wash fractions, and the washed insoluble Avicel pellet. Similarly, the association of β -D-mannanase activity with 1.0, 0.5, and 0.2 % (w/v) solka floc and 0.5, 0.2, and 0.1 % (w/v) of each xylan was assessed.

3. Impact on apparent kinetic parameters.

The possibility that Avicel or larch wood could alter the apparent kinetic parameters of β -D-mannanase towards locust bean gum β -D-galactomannan was explored by the addition of 1.0 % (w/v) Avicel, 0.1% (w/v) Avicel and 0.25 % (w/v) larch wood to the locust bean gum β -D-galactomannan used in the kinetic studies. The kinetic parameters were then determined as described earlier.

G. The interaction of *T. harzianum* β -D-mannanase with other hemicellulases.

The increase in reducing sugars released resulting from β -D-mannanase 6.55 in combination with xylanase (EC 3.2.1.8), acetyl xylan esterase (EC 3.1.1.6), and α -galactosidase (EC 3.2.1.22), using 0.5% (w/v) black spruce lignin carbohydrate (LCC) as substrate was determined after 2 hours incubation at 50 ° C in sodium acetate buffer, pH 4.8. The endoxylanase was a purified protein isolated from culture filtrates of *T. harzianum* and was a gift from Dr. David Senior (Forintek Canada Corp.). α -Galactosidase was isolated from the second peak of α -galactosidase activity detected during ion exchange chromatography procedure described earlier. Acetyl xylan esterase from *Schizophyllum commune* was a purified protein received from Dr. K.G. Johnson (NRC Canada, Ottawa). The number of units of each enzyme added to the substrate

solution were as follows: α -galactosidase 400 , acetyl xylan esterase 100, endoxylanase 700, and β -D-mannanase 200. Immediately following incubation, the reducing sugars released from the LCC by each enzyme combination was determined by the Nelson-Somogyi method.

RESULTS

I. Detection and Determination of β -Mannan Degradation by Various Fungi

The ambiguous nature of the term mannan, the lack of a standard assay, and the lack of a standard unit of activity or method for reporting β -mannanase activity, are all factors that make it extremely difficult to select a candidate fungi for β -D-mannanase studies based on the literature alone. Therefore, hemicellulolytic yeast and filamentous fungi already under study in the Forintek laboratories were screened for their ability to degrade β -D-mannan. *Aspergillus niger* and *Tyromyces palustris*, two fungi reported to be capable of β -mannanase production, were included as positive controls to ensure that the assays used to monitor β -D-mannan degradation and extracellular β -D-mannanase production were effective. All 9 test microorganisms listed in Table 4 were capable of growth on solid agar in the presence of locust bean gum β -D-galactomannan. When grown in liquid culture, neither *Pichia wickerhammi*, *Candida wickerhammi*, *Thielavia* spp., nor *Thermoascus aurantiacus* utilized a significant proportion of the mannan. However their growth did result in lower degrees of substrate polymerization (Table 4). *Trichoderma harzianum* E58 utilized 43% of the substrate and lowered the degree of polymerization (DP) 12-fold compared with the DP value observed in the uninoculated media after 14 days incubation (Table 4).

The Congo red agar assay for detection of solubilized β -D-mannan indicated that culture filtrates of *T. harzianum* E58 supplemented with both mannan rich and non-mannan polysaccharides were able to hydrolyze β -D-galactomannans and β -D-glucomannan. After flooding β -D-mannan agar plates with Congo red, sites where culture

Table 4. Mannan utilization by selected organisms

Fungi	Percent substrate utilized^a	Degree of Polymerization of residual substrate^b
Uninoculated media	0	224
<i>Aspergillus niger</i> 207E	89	18
<i>Candida wickerhammi</i> 689A	<5	32
<i>Pichia wickerhammi</i> 689B	<5	35
<i>Pichia stipitis</i> CBS5776	20	26
<i>Pichia stipitis</i> CBS5876	17	20
<i>Thievalia</i> spp. CMI131014	<5	33
<i>Thermoascus aurantiacus</i> C436	<5	30
<i>Trichoderma harzianum</i> E58	43	18
<i>Tyromyces palustris</i> A 227A	46	5

^a Organisms were grown for 14 days at 28° C (thermophiles at 44 ° C), on a gyrorotary shaker (150 rpm). After 14 days growth in yeast peptone medium supplemented with 1% (w/v) locust bean gum, the amount of sugar remaining in the culture filtrates was determined by the phenol sulfuric assay for total sugars.

^b The degree of polymerization of the substrate (DP) was calculated by dividing the amount of total sugar remaining by the reducing sugar equivalents remaining in the culture filtrates.

filtrates of *T. harzianum* E58 had been applied exhibited distinct clearing zones. Since *T. harzianum* appeared to be capable of high β -D-mannan utilization and to possess depolymerizing activity, it was selected for further study.

II. Production of β -Mannanase Active Enzymes by *T. harzianum* E58

A. Production of β -mannanase activity by *T. harzianum* E58 grown on mannan-rich and non-mannan polysaccharide media.

The enzymatic activity, pH, and reducing power were monitored in culture filtrates of *T. harzianum* grown in modified Mandels medium containing 1% (w/v) Avicel, oat spelts xylan, spruce water solubles (SWS), konjac root powder, or locust bean gum (Figure 4; Figure 5). Three replicate flasks of each medium type were sampled for 12 -14 days. Variation in data obtained from replicate flasks was less than 9.5%. During growth of the fungi, the pH of the medium containing konjac or locust bean gum remained relatively stable at pH 5.8 - 6.3. In all other media, the pH of the filtrate dropped during the first 4-5 days of incubation and then rose to approximately pH 6.3 within 3 days (Figure 4a).

While the level of reducing sugars in the SWS medium decreased during the first 4 days of incubation, reducing sugars were not detected in culture filtrates from medium containing konjac root powder or Avicel. During growth on locust bean gum medium, the levels of reducing sugars increased slightly when β -mannanase was first detected in the culture filtrate (Figure 4b). The Congo red agar assay for β -mannanase activity

Figure 4. The production of β -mannanase activity and changes in the medium during growth of *Trichoderma harzianum* E58 on modified Mandels medium (28° C, 150 rpm) containing 1% (w/v) of Avicel, locust bean gum, konjac root powder β -glucomannan, or, spruce water solubles; a) pH Profile of culture filtrate; b) Reducing sugar equivalents in the culture filtrates. The incubation time when mannanase activity was first detected in the culture filtrate is denoted by "↓" on figure a).

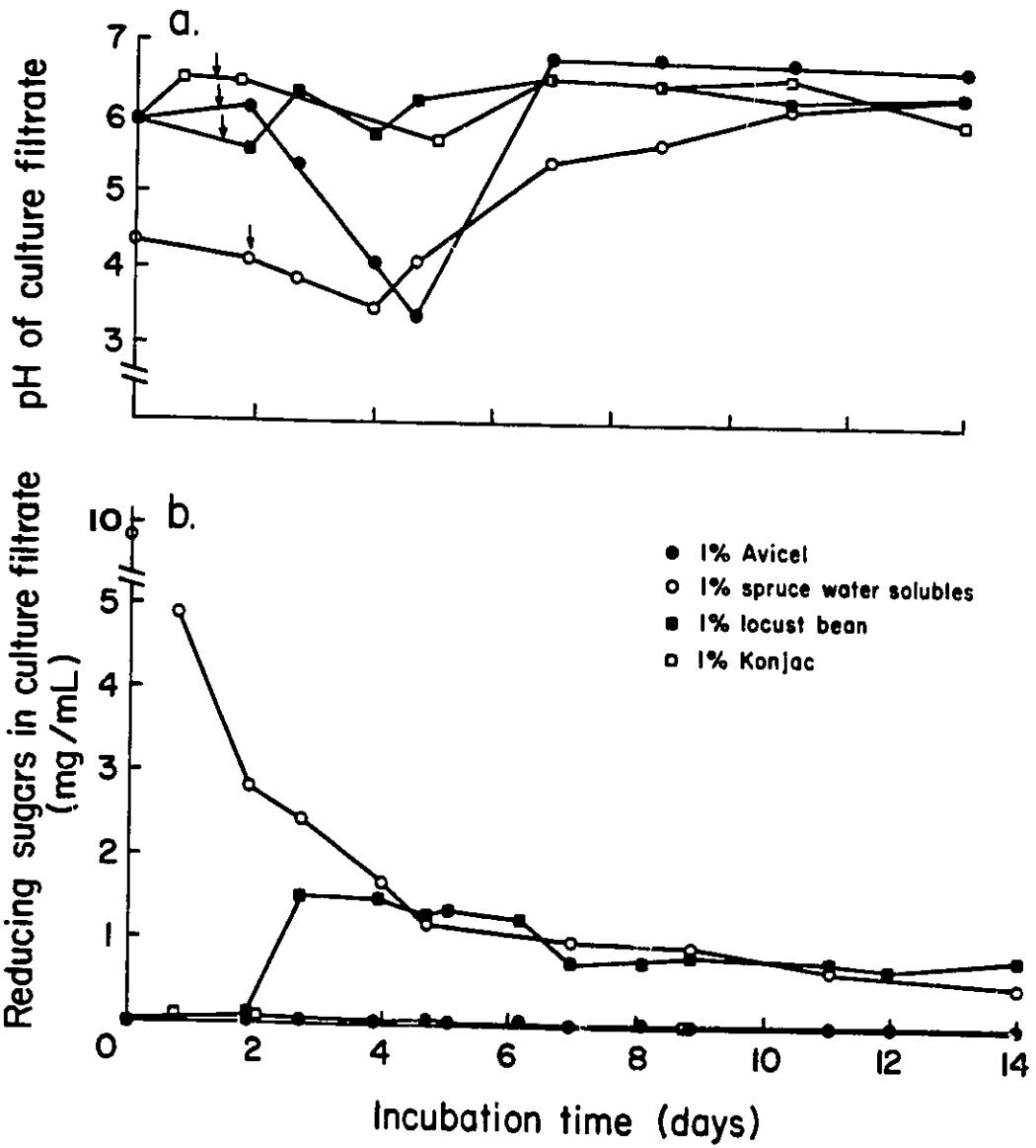
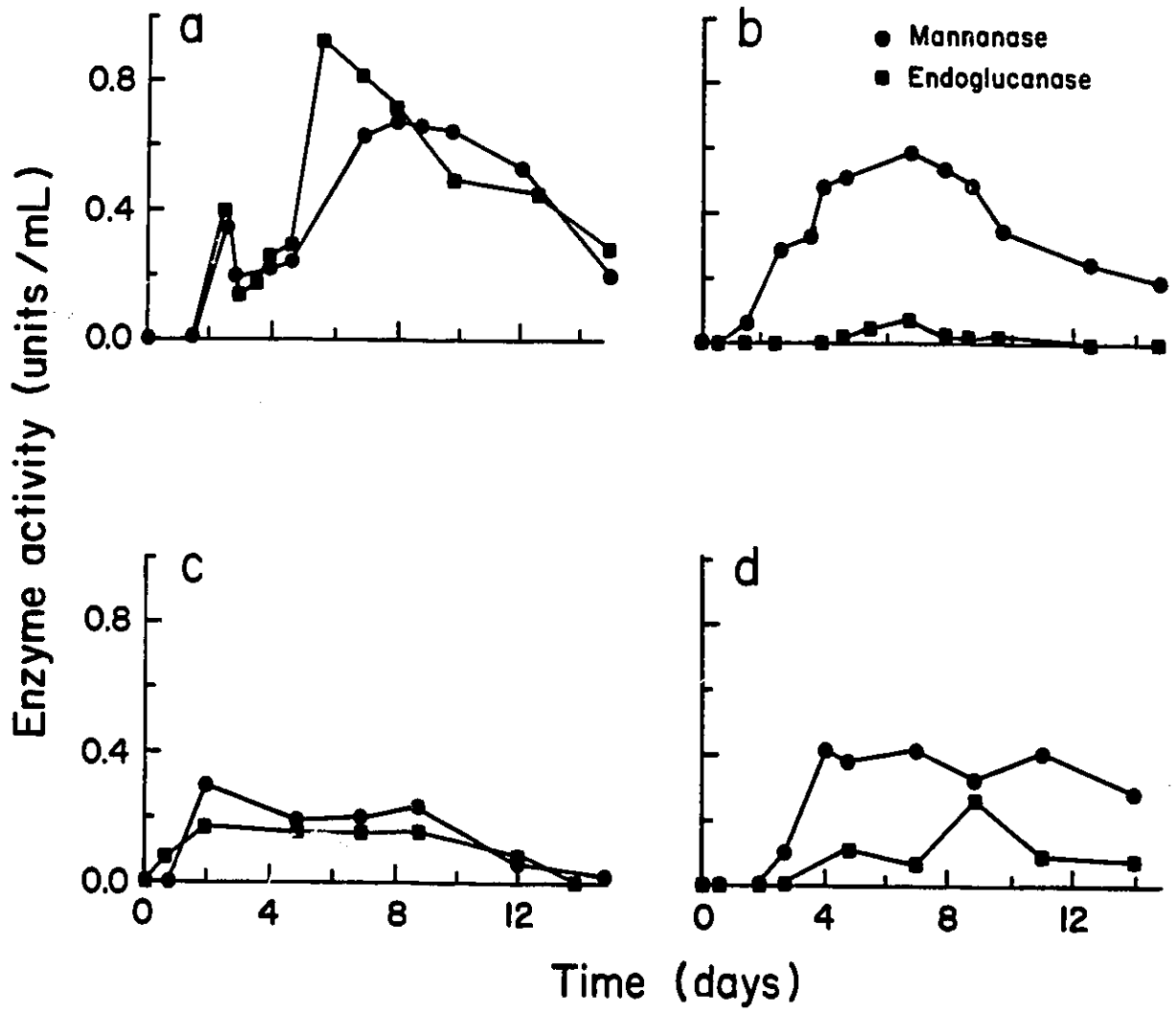

Figure 5. Enzyme production by *Trichoderma harzianum* E58 grown (28°C, 150 rpm) on modified Mandels medium containing 1% (w/v), a) Avicel; b) Locust bean; c) Konjac root powder; d) Spruce water solubles. One unit of enzyme activity was defined as the amount releasing 1 μ mol of reducing equivalents per minute from 0.5% (w/v) of the assay substrate. Locust bean gum β -D-galactomannan was used as the β -mannanase assay substrate. Endoglucanase activity was determined using carboxymethyl cellulose as the assay substrate.



detected the ability to solubilize both konjac root powder β -D-glucomannan and locust bean gum β -D-galactomannan in culture filtrates from medium containing Avicel, konjac root powder, and SWS, 10 to 24 hours before β -mannanase activity was detected by the reducing sugar assay.

The level of β -mannanase activity detected in the culture filtrates during growth differed depending on the media supplement. In culture filtrates from medium containing 1% (w/v) xylan, no β -galactomannanase activity was detected by the reducing sugar assay. However, β -galactomannanase activity, as measured by the Nelson-Somogyi reducing sugar assay, was detected after 2 to 3 days growth in culture filtrates from SWS, locust bean gum, Avicel, and konjac root powder media (Figure 5). Growth on medium containing SWS or konjac root powder resulted in consistent but relatively lower β -mannanase values (units/mL filtrate) than those obtained after growth on Avicel or locust bean gum media. The highest levels of β -mannanase activity from these cultures were detected after 6 to 8 days growth. Although Avicel and locust bean gum culture filtrates exhibited maximum β -galactomannanase levels of 0.66 and 0.60 units per mL of filtrate respectively (Figure 5), β -galactomannanase and β -glucomannanase specific activities were 3.6 and 3.8 fold greater in culture filtrates from medium containing locust bean gum compared with the specific activities obtained after growth on Avicel medium (Table 5).

In all media, the time-course production of β -mannanase and endoglucanase were similar (Figure 5). However, the endoglucanase values obtained after growth on mannan-rich media were less than 60% of the equivalent value obtained after growth on Avicel (Figure 5; Table 5). The ratio of galactomannanase to endoglucanase activities found in

Table 5. Extracellular enzyme activities detected after growth of *Trichoderma harzianum* on various substrates^a.

Substrate (1 %w/v)	Specific enzyme activity (Units/mg protein)			IEF protein bands with detectable mannanase activity ^b (pI values)
	β -D- Galacto- mannanase	β -D- Gluco- mannanase	Endo- glucanase	
Avicel PH101	7.4	2.8	8.2	6.55 5.59 4.8 4.35 < 4.0
Locust bean gum	26.7	10.7	3.3	6.55 5.59 4.8
Konjac root powder	7.5	4.5	4.2	6.55 5.59 4.8
Spruce water solubles	3.7	2.7	1.8	6.55 4.8 4.35 < 4.0
Mannose	N.D.	N.D.	1.3	N.D.
Mannose + 0.5% locust bean gum	7.2	2.9	1.4	6.55 5.59 4.8 4.35 < 4.0
Oat spelts xylan	N.D.	N.D.	5.9	6.55 5.59

^a Activities reported were taken on the day when peak mannanase activity (Units/ml) was detected, usually after 6-8 days incubation. Assays were carried out as described in the text.

^b Culture filtrates were analyzed by isoelectric focussing (IEF) and the protein bands having mannanase activity determined by the β -D-galactomannan zymogram analysis as described in the text.

N.D. None detected.

the culture filtrates when β -mannanase activity (Units/mL) was maximal appeared to reflect the original mannose to glucose ratio within the growth medium (Table 6).

B. β -D-Mannanase production in the presence of mannose.

T. harzianum grown in medium supplemented with increasing concentrations of mannose alone (up to 1.0% w/v), did not produce detectable extracellular β -mannanase activity (Table 5), although extracellular protein was detected (Figure 6). However, activity was detected in culture filtrates of media containing 0.1 - 1.0% (w/v) locust bean gum in addition to 0.1 - 1.0% (w/v) mannose. In all media supplemented with 0.5 -1.0 % (w/v) mannose, the pH of the medium dropped below 4 within the first 2-3 days of growth and then slowly increased to initial levels. In the culture filtrates of locust bean gum medium supplemented with 0.5 -1.0% (w/v) mannose, β -D-mannanase activity could be detected before the mannose supplement had been completely utilized (Figure 6). The presence of mannose did not affect the level of activity nor did it affect the time-course production profile of the β -galactomannanase activity in medium containing locust bean gum. The presence of mannose did not induce β -mannanase production nor did it repress production at levels that could be expected in medium containing 0.5% - 1.0% (w/v) β -mannan. However, a higher maximal level of β -galactomannanase activity was reached in medium containing 1.0 % (w/v) locust bean gum than reached in medium containing 0.5% (w/v) locust bean gum (Figure 6).

Table 6. The influence of substrate composition on the relative endoglucanase and galactomannanase activities in *Trichoderma harzianum* E58 culture filtrates.

Substrate (1% w/v)	Ratio of mannose to glucose in growth substrate.	Ratio of galactomannanase to endoglucanase activities in culture filtrate.
Avicel	0.01	0.9
Konjac root powder	1.33	1.8
Spruce water solubles	2.68	2.1
Locust bean gum	49.80	8.1

Figure 6. The β -galactomannanase activity, protein content, and pH of culture filtrates of *Trichoderma harzianum* E58 grown (28 °C, 150 rpm) on Mandels medium containing a) 1% (w/v) Locust bean gum, b) 0.5% (w/v) Mannose + 0.5% (w/v) locust bean gum, c) 1% (w/v) Mannose.

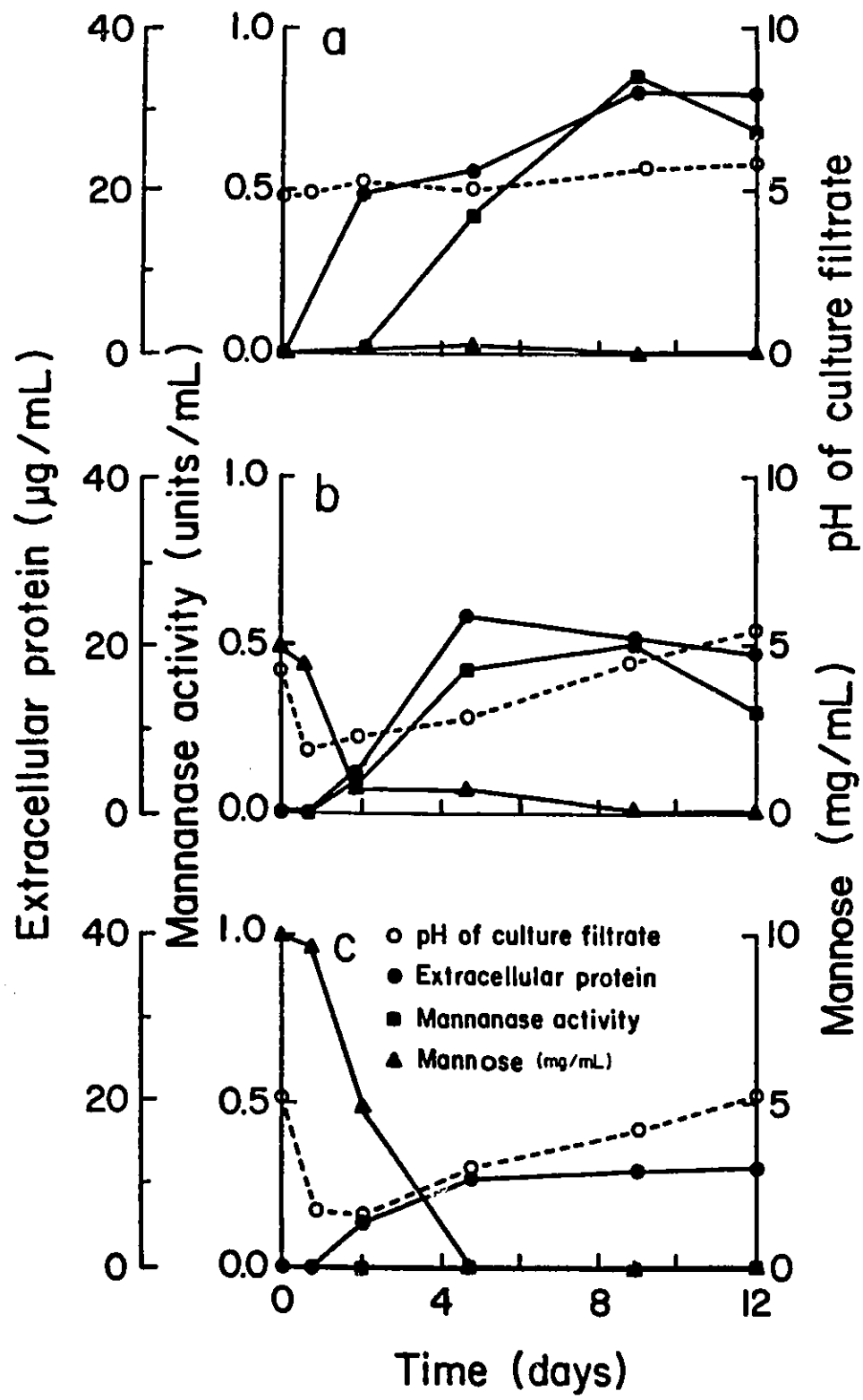

III. Zymogram Detection of β -Mannanase Proteins in Culture Filtrates of *T. harzianum* E58

When maximal β -mannanase activity levels (units/mL) were observed in culture filtrates derived from locust bean gum and konjac root powder supplemented media, the protein levels expressed as mg per mL of filtrate, were less than half of those found in Avicel or SWS culture filtrates. This observation was visually confirmed by silver staining of the isoelectric focused gels of the culture filtrates (Figure 7a).

For a given culture filtrate, zymogram patterns of β -galactomannanase and β -glucomannanase activities were similar. However, culture filtrates from the different medium varied in the number of protein bands having detectable β -mannanase activity (Figure 7). Enzymes with low isoelectric points ($\text{pH} \leq 4.5$) were detected in filtrates from spruce water solubles and Avicel media. When 0.5% (w/v) locust bean gum medium was supplemented with 0.5% (w/v) mannose, these acidic β -mannanases were also detected. At mannose levels lower than 0.1% (w/v) the acidic proteins with β -D-mannanase activity were not detected. Moreover, proteins with low pI values ($\text{pH} \leq 4.5$), from culture filtrates of medium containing only locust bean gum or konjac root powder did not exhibit detectable levels of β -mannanase activity (Figure 7). In all cases, the β -mannanase activity associated with proteins with acid pI values was detected only when the medium pH had fallen below 4.5. Zymogram analysis did not detect β -mannanase

Figure 7a. Silver stain profiles of proteins present in culture filtrates of *Trichoderma harzianum* E58 separated by isoelectric focusing. Lanes from left to right contain 1.0 μ L of 7 day culture filtrate after growth in modified Mandels medium containing (w/v); a) 1.0% Avicel, b) 1.0% Locust bean, c) 1.0% Konjac, d) 1.0% Spruce wood water solubles, e) 1.0% Oat spelts xylan, f) 1.0% Mannose, g) 1.0% Mannose + 0.5% locust bean.

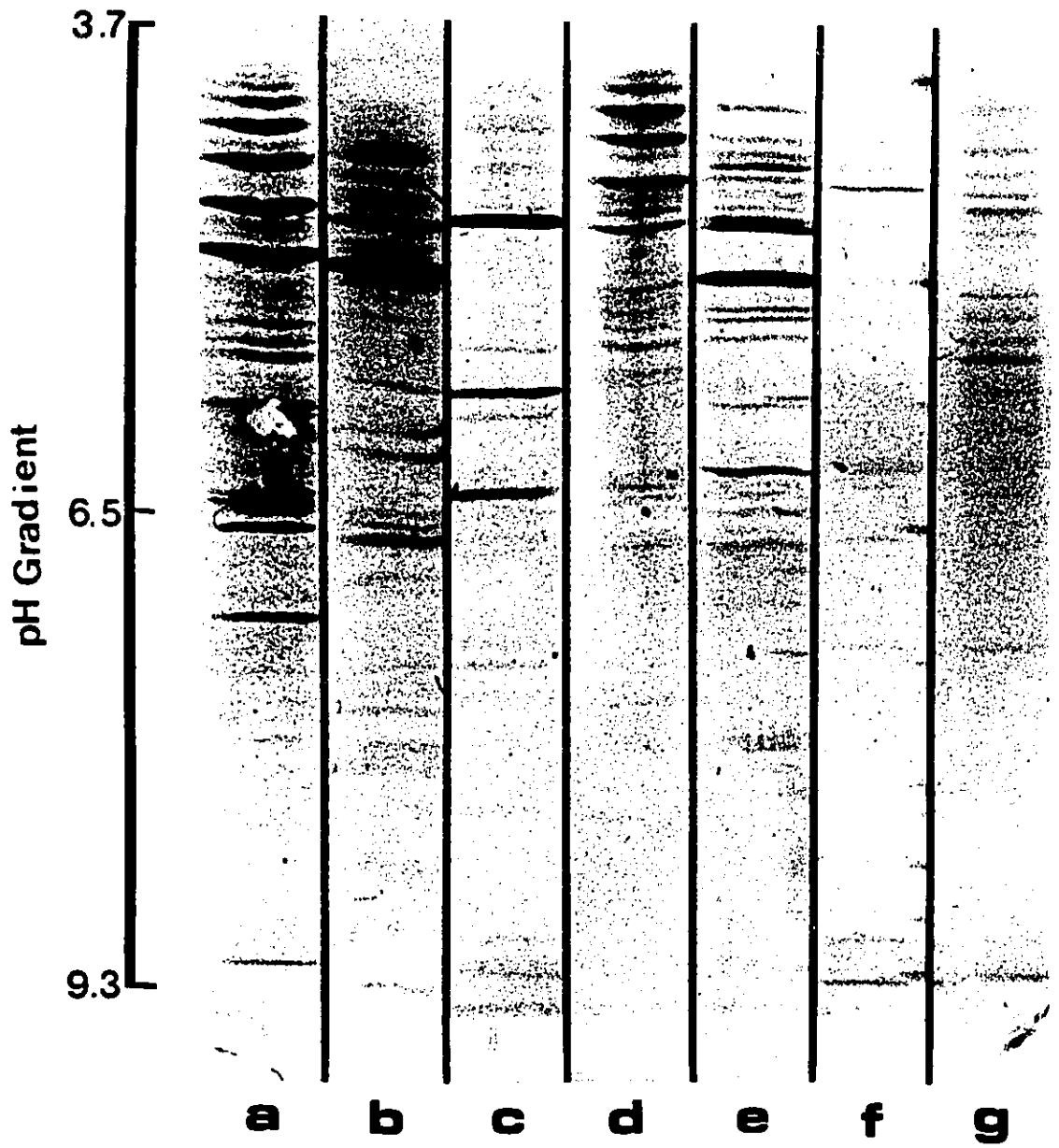
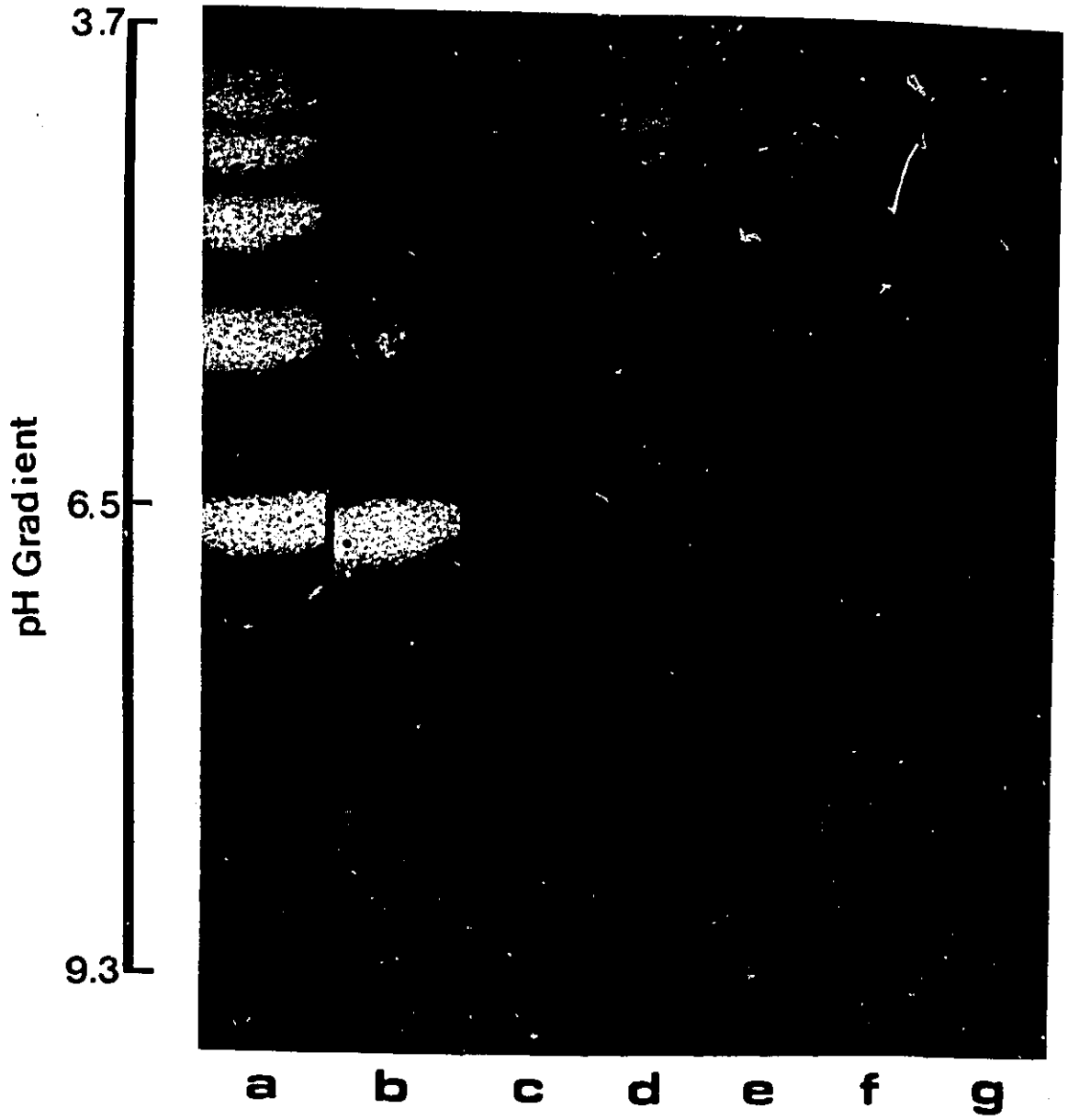

Figure 7b. β -Galactomannanase zymogram profiles of proteins present in culture filtrates of *Trichoderma harzianum* E58 separated by isoelectric focusing. Lanes from left to right contain 1.0 μ L of 7 day culture filtrate after growth in modified Mandels medium containing (w/v); a) 1.0% Avicel, b) 1.0% Locust bean, c) 1.0% Konjac, d) 1.0% Spruce wood water solubles, e) 1.0% Oat spelts xylan, f) 1.0% Mannose, g) 1.0% Mannose + 0.5% locust bean.



activity in culture filtrates from cultures grown in medium supplemented with only mannose (Figure 7), confirming the results of the β -mannanase reducing sugar assay (Figure 6c).

Although growth in medium containing xylan did not produce detectable β -mannanase as measured by the reducing sugar assay, faint bands in the acidic region of the IEF gel were detected by konjac root powder β -D-glucomannan and locust bean gum β -D-galactomannan zymogram analysis, indicating that trace levels of β -mannanases were present in the filtrate (Table 5; Figure 7b).

When culture filtrates from locust bean gum medium were concentrated to the same protein concentration as that found in Avicel medium culture filtrates, the acidic β -mannanases were still not detected. However, locust bean gum culture filtrates concentrated to more than 10-fold the protein concentration of the other filtrates produced faint β -mannanase bands of clearing in the pI range of 3 - 4.5. This indicated that either the acidic proteins present possessed relatively low levels of β -mannanases, or were present in much smaller proportions compared with the total extracellular protein present in Avicel, SWS, xylan, or mannose supplemented locust bean gum culture filtrates.

Incorporation of 1% (w/v) mannose into the zymogram substrate agar did not alter the β -mannanase activity profile of any tested culture filtrate, suggesting that all detected β -mannanases were capable of solubilizing locust bean gum or konjac root powder in the presence of 1% (w/v) mannose. This result was confirmed by the reducing sugar enzyme assay data in that, when 1% (w/v) mannose was added to the assay, β -mannanase levels were unaffected. Similarly, incorporation of 1% (w/v) SWS into either the enzyme assays or the zymogram agar did not result in any change in measured enzyme levels.

The β -mannanase activity within the culture filtrates was relatively stable. After 2 weeks of storage at 4° C, 85 -90% of the initial activity remained. After 12 months of storage, culture filtrates from Avicel or locust bean gum media retained 80-85 % of their original β -mannanase activity. The β -mannanase zymogram profile of the supplemented cultures did not change even after 12 months storage.

When culture filtrates from Avicel-grown cells were separated by IEF and the protein bands were assayed directly by the overlay zymogram technique (Figure 8), most of the bands exhibiting β -mannanase activity also possessed some endoglucanase activity. The protein band with a pI of 6.55 was active on both β -D-galactomannan and β -D-glucomannan. This protein was detected in all culture filtrates that possessed detectable β -mannanase activity (Figure 7). Zymograms of the filtrates from cells grown on locust bean gum and Avicel showed that this protein band was devoid of any endoglucanase activity (Figure 8). Since there was considerable interest in obtaining a protein or group of proteins possessing β -mannanase activity but lacking endoglucanase activity, efforts were focused on the isolation and characterization of this protein, which was provisionally designated β -mannanase 6.55.

Figure 8a. Zymogram and protein staining of culture filtrates from *Trichoderma harzianum* E58 grown on 1.0% (w/v) Avicel medium and separated by isoelectric focusing. Lanes from left to right contain; a) Silver stain of culture filtrate proteins, b) 0.5% (w/v) β -D-Galactomannan zymogram, c) 0.5% (w/v) Carboxymethyl cellulose endoglucanase zymogram, d) 0.5% (w/v) β -D-Glucomannan zymogram. The arrow indicates the focused protein band exhibiting glucomannanase and galactomannanase activity but not endoglucanase activity.

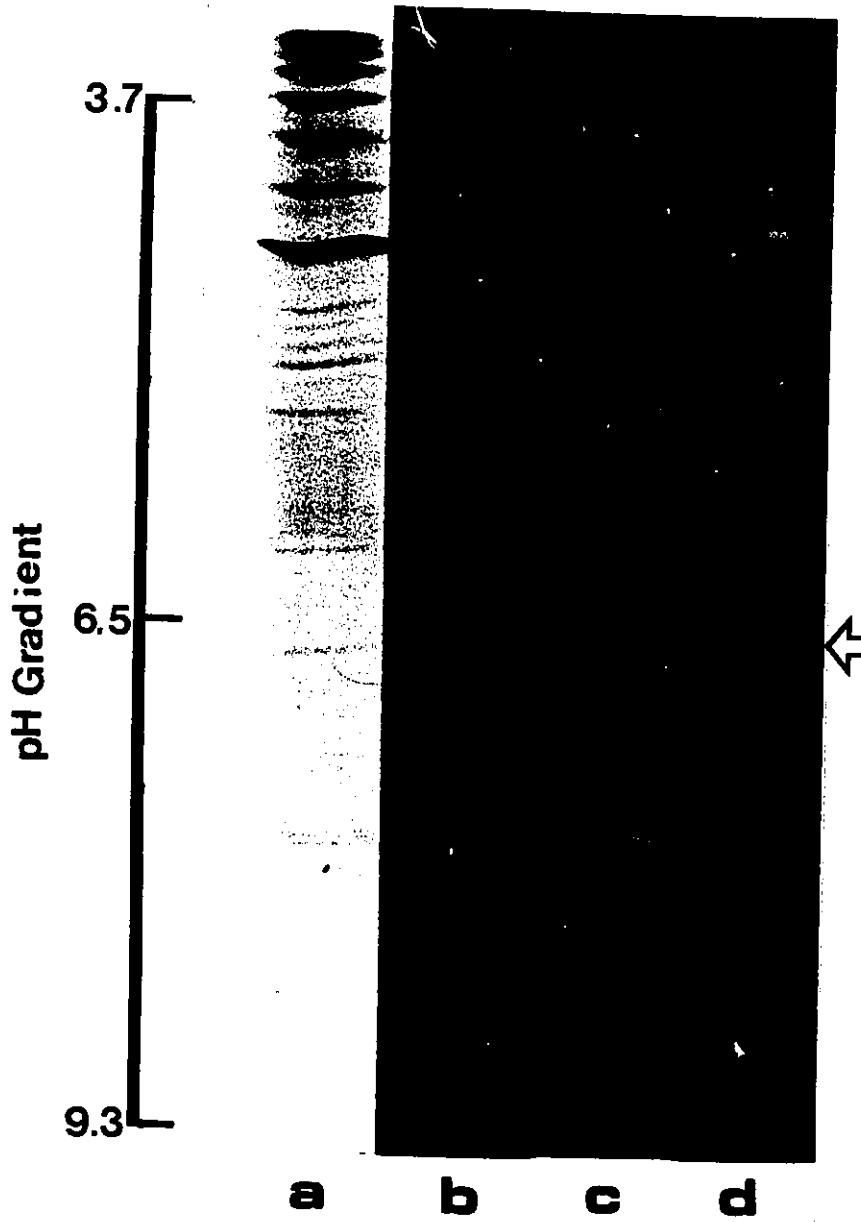
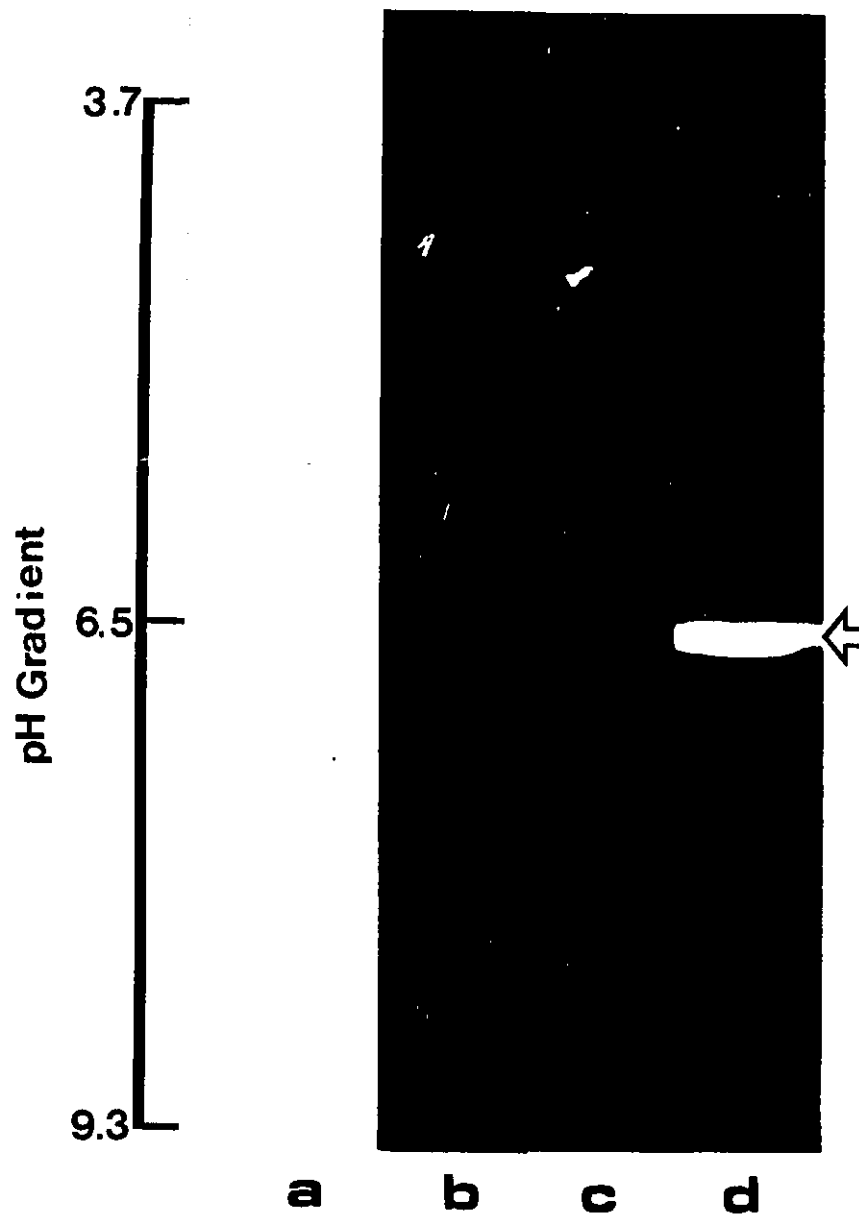

Figure 8b. Zymogram and protein staining of culture filtrates from *Trichoderma harzianum* E58 grown on 1.0% (w/v) locust bean gum medium and separated by isoelectric focusing. Lanes from left to right contain; a) Silver stain of culture filtrate proteins, b) 0.5% (w/v) β -D-Galactomannan zymogram, c) 0.5% (w/v) Carboxymethyl cellulose endoglucanase zymogram, d) 0.5% (w/v) β -D-Glucomannan zymogram. The arrow indicates the focused protein band exhibiting glucomannanase and galactomannanase activity but not endoglucanase activity.



IV. Isolation and Properties of Extracellular β -Mannanase 6.55 from *T. harzianum* E58 Culture Filtrate.

Throughout the characterization and isolation of β -mannanase 6.55, β -glucomannanase and β -galactomannanase activities were monitored by the Nelson-Somogyi reducing sugar assay using konjac root powder β -D-glucomannan and locust bean gum β -D-galactomannan as the respective assay substrates. All values presented are averages of 2 - 4 replicate samples. Variation among replicate samples was less than \pm 5.5 % of the average value reported. Experiments to determine the effect of incubation time upon the detected hydrolysis of these mannans demonstrated that, under the assay conditions employed (30 minutes, 50 ° C, 25 mM sodium acetate buffer, pH 4.8, and 0.5% (w/v) substrate) the detected rate of hydrolysis was linear. For both locust bean gum and konjac root powder mannans the rate of reducing sugar equivalents released was linear for the first 2 hours of incubation (Figure 9).

A. Isolation of β -mannanase 6.55.

T. harzianum E58 culture filtrate from cultures grown for 6 days in modified Mandels medium containing 1% (w/v) locust bean gum served as a source material for the enzyme. Purification of β -mannanase 6.55 activity was achieved by sequential ultrafiltration, anion exchange chromatography, and gel filtration as described below. Throughout the sequence, the hydrolytic activity of the various fractions towards a variety of substrates was monitored to determine the best strategy to isolate β -mannanase 6.55. Results are tabulated in Tables 7 and 8.

Figure 9. The effect of incubation time upon locust bean gum β -D-galactomannan and konjac β -D-glucomannan hydrolysis by *Trichoderma harzianum* E58 β -mannanase 6.55.

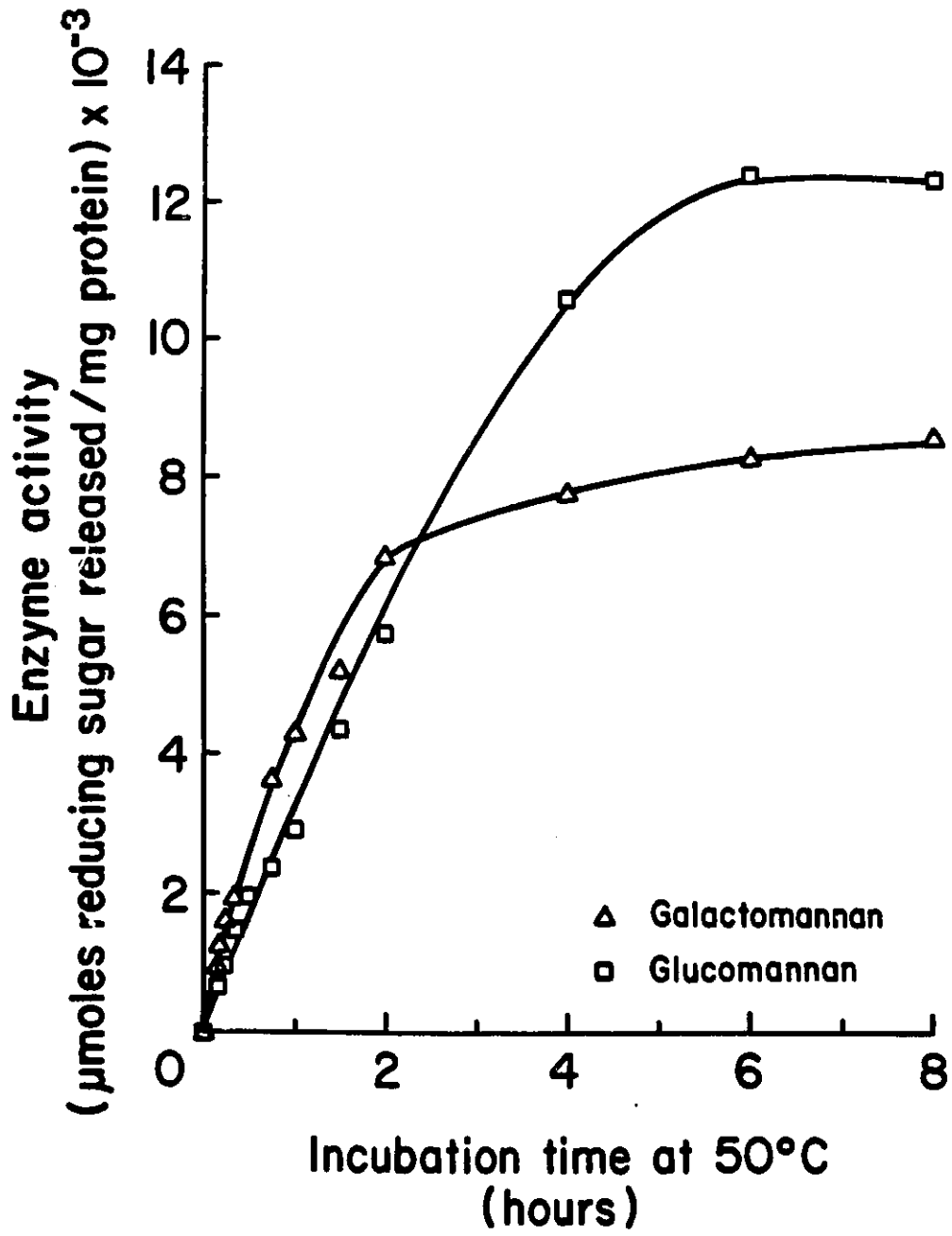

Table 7. Purification of the β -mannanase activity from the culture filtrate of *Trichoderma harzianum* E58 grown on 1% (w/v) locust bean gum.^a

Purification Step	Protein (mg/mL)	Percent Relative Protein	Specific Activity^b (Units/mg protein)	Percent of Original Mannanase Activity Recovered^b
Culture filtrate	0.021	100	26.0 14.8	100
Desalted concentrate (Pelicon 10kD membrane Retentate)	0.997	57.38	33.4 22.0	70.9 85.2
Anion Exchange (DEAE Sepharose CL-6B)	0.215	8.87	74.6 38.7	26.4 23.2
Gel Filtration (Sephadex G100)	0.254	5.61	73.4 41.7	15.2 15.8

^a The fungus was grown in a liquid culture of modified Mandels medium containing 1% (w/v) locust bean gum inoculated with a 4 day mycelium culture. After 6 days growth (150 rpm, 28 °C) the culture filtrate was harvested by vacuum filtration using Whatman glass microfibre filters.

^b The first value is β -galactomannanase activity measured using locust bean gum β -D- galactomannan as the assay substrate. The second value refers to β -glucomannanase activity measured using konjac root powder β -D-glucomannan as the assay substrate.

Table 8. Enzyme activities measured during the isolation of β -mannanase activity found in *Trichoderma harzianum* E58 culture filtrate.

Assay Substrate	Specific Activity at each Separation Step (Units/mg protein)				
	Crude Culture Filtrate ^a	Pellicon Filtrate ^b	Pellicon Retentate ^b	Anion Exchange	Gel Filtration
p-nitrophenol- β -D-mannopyranoside	0.54	< 0.03	0.12	0.04	< 0.03
p-nitrophenol- β -D-glucopyranoside	0.21	< 0.03	0.18	< 0.03	—
p-nitrophenol- β -D-xylopyranoside	0.45	< 0.03	0.44	< 0.03	—
p-nitrophenol- α -D-galactosidase	4.21	< 0.03	4.66	0.05	< 0.03
Mannans:					
Konjac root powder	14.80	7.33	22.00	38.73	41.67
Locust bean gum	26.01	7.40	33.44	74.63	73.41
Guar gum	22.01	10.38	25.74	28.80	27.16
Pine (glucomannan)	24.33	9.25	18.09	34.96	44.24
Yeast α -mannan	4.08	6.93	1.12	< 0.03	—
Celluloses:					
Avicel PH101	1.71	4.50	0.63	< 0.03	< 0.03
Carboxymethyl-cellulose	8.01	< 0.03	7.57	0.45	< 0.03
Xylans:					
Oat spelt	8.19	18.18	2.15	< 0.03	—
Larchwood	13.32	34.95	8.77	< 0.03	—

^a The fungus was grown in a liquid culture of modified Mandels medium containing 1% (w/v) locust bean gum and inoculated with a 4 day mycelium culture (5% v/v). After 6 days growth (150 rpm, 28 °C) the culture filtrate was harvested.

^b The culture filtrate was concentrated using a Pellicon ultrafiltration cell equipped with 10 kD membranes and a smaller ultrafiltration cell equipped with YM-10 membranes. The retentate was then desalted and designated Pellicon retentate.

STEP 1: Ultrafiltration.

When the culture filtrate of *T. harzianum* E58 grown on 1% (w/v) locust bean gum medium was concentrated by ultrafiltration using a Pellicon cell equipped with 10kD membranes, both β -glucomannanase and β -galactomannanase activities were found in the retentate. The specific activities of β -galactomannanase and β -glucomannanase were 1.28 and 1.49 fold greater than that found in the original culture filtrate (Table 7). In contrast, Avicel degrading enzymes, α -mannanase and xylanase activities appeared to be concentrated in the Pellicon ultrafiltrate (Table 8). Overall, ultrafiltration recovered 70.9 - 85.2 % of the original β -mannanase activity and resulted in a 1.3 - 1.5 fold increase in β -mannanase specific activity.

STEP 2: Anion exchange chromatography on DEAE-Sepharose.

Ion exchange chromatography was selected as a possible method for separating β -mannanase activity from the other enzyme activities found in the retentate (Table 8). Since the protein of interest had a pI near neutrality either cation or anion exchange columns could have been chosen. However, preliminary experiments indicated that β -mannanase activity could not be detected in the effluent of cation exchangers washed with buffers of increasing pH from 3.7 - 4.8 nor could it be eluted by 0.45 M NaCl. Cation exchange columns at pH 5.5 and anion exchange columns at pH 7.0, 7.45, or 8.1 retained less than 65% of input β -mannanase activity. However, anion exchange mini-columns equilibrated at pH 8.6 retained more than 85% of the input activity, while mini-columns at pH 9.1 bound all β -mannanase activity. For this reason, anion exchange

chromatography was selected as the second purification step. To ensure that active β -mannanase was bound, but not to the extent that strong salt solutions would be required for elution, DEAE-Sepharose CL-6B equilibrated with low ionic strength buffer (10 mM) at pH 8.6 was used for large scale enzyme purification.

A series of 15 mL mini-columns of DEAE-Sepharose were equilibrated with 10 mM TrisHCl buffer, pH 8.6, containing a range of NaCl concentrations (0 - 0.3 M), to determine an optimal range for application of a linear salt gradient to elute bound proteins. β -Mannanase activity did not bind to the column equilibrated with 0.3 M NaCl but 69% of input β -mannanase activity was bound to the column equilibrated with 0.1 M NaCl. β -Mannanase activity levels detected in the effluent of columns equilibrated with lower salt concentrations did not differ significantly from the levels detected in control exchange columns (0 mM NaCl, pH 8.6 anion exchange). Based on these results, a salt gradient from 0 to 0.4 M NaCl was chosen and applied over 220 mL of buffer to achieve good resolution with complete elution of the original β -mannanase activity added.

The elution profile of *T. harzianum* E58 ultrafiltration retentate after fractionation on DEAE-Sepharose is presented in Figure 10. All input β -xylanase activity was eluted in the column buffer wash. β -Glucomannanase and β -galactomannanase activities began to elute from the column at a salt concentration of approximately 35 mM. α -Galactosidase activity eluted in two peaks after the major β -mannanase peak. Neither endoglucanase nor β -mannobiase were detected in individual effluent fractions. A second run of the column demonstrated the reproducibility of this protein and activity profile.

Figure 10. Anion exchange chromatography of *Trichoderma harzianum* E58 ultrafiltration retentate. Fifty mg of protein were applied to a 2.6 cm x 23 cm DEAE-Sepharose column equilibrated with 10 mM Tris-HCl buffer, pH 8.6, containing 0.2% (w/v) azide. Ultra-retentate originated from the culture filtrate of *Trichoderma harzianum* grown for 6 days (28 °C, 150 rpm) in modified Mandels medium containing 1% (w/v) locust bean gum.

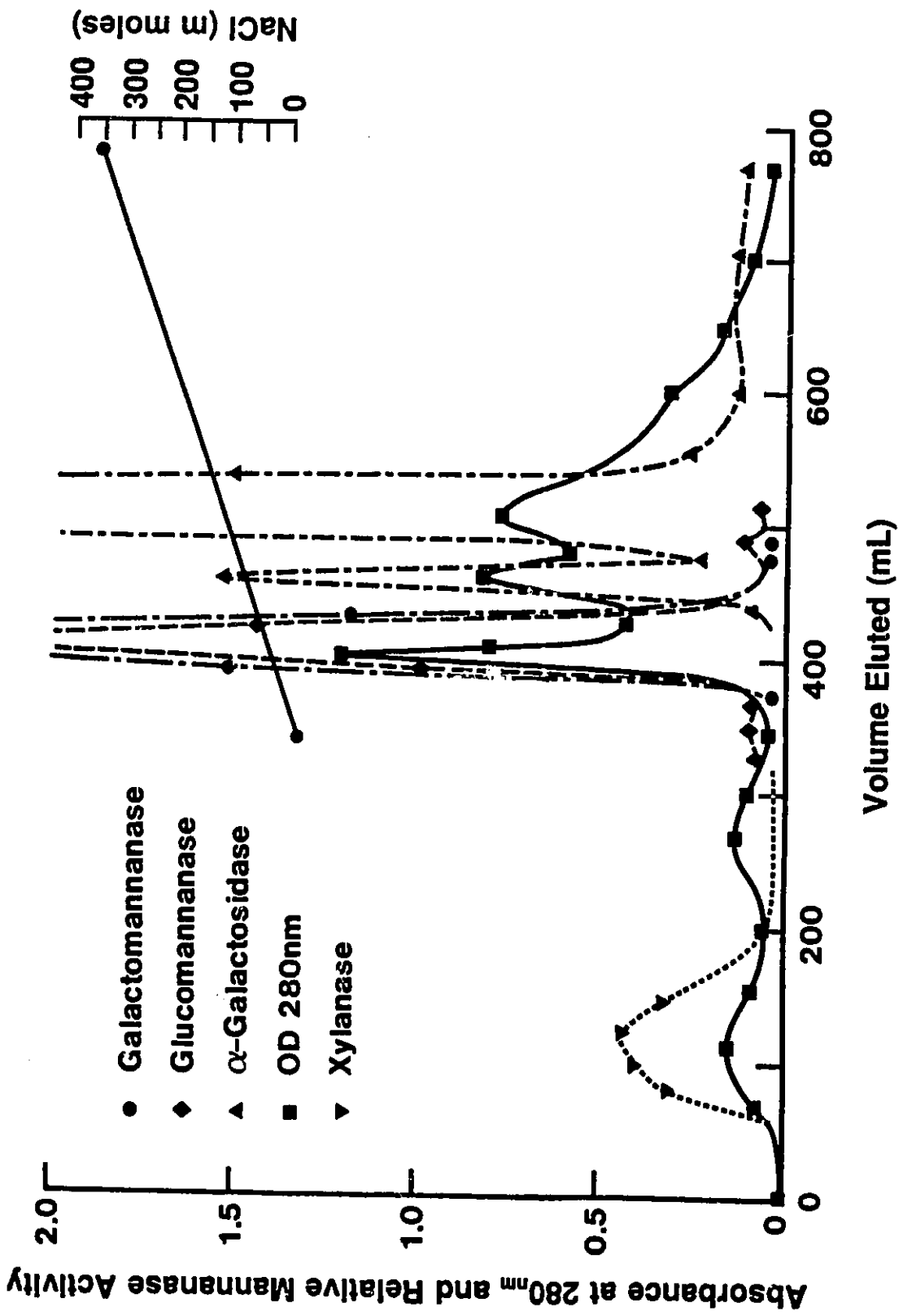

Anion exchange fractions possessing relative β -mannanase activity equal to or greater than 1.7 were pooled. The increase in the specific activity towards konjac root powder, locust bean gum, pine glucomannan and guar in comparison with the original filtrate was 2.62, 2.87, 1.44 and 1.31 fold respectively (Table 8). At this stage, the pooled β -mannanase fractions contained trace amounts of α -galactosidase and β -endoglucanase activities. Zymogram analysis revealed that the β -mannanase activity was associated with a major protein of pI 6.55 and a minor protein of pI 5.6.

STEP 3: Gel filtration.

To remove the contaminating enzyme activity, pooled anion exchange fractions were concentrated using a Amicon ultrafiltration cell equipped with a YM-10 membrane and were subjected to gel filtration. The elution profile of the material from a Sephadex G-100 gel filtration column is presented in Figure 11. This column was calibrated with a series of proteins of known molecular weight and its void and total volume calculated to be 84.8 and 243.8 mL respectively. The major protein peak associated with β -mannanase activities had a K_{av} value of 0.321 which corresponded to a molecular weight of 39.8 kDaltons. Prior to pooling fractions containing β -mannanase activity, aliquots of each fraction were examined by IEF and SDS gel electrophoresis. Only those fractions containing single bands as visualized by coomassie blue were pooled. Silver staining of the protein profile obtained by SDS-PAGE PhaseGel (10/15 gradient) gel electrophoresis of these pooled β -mannanase fractions revealed a single peak with an estimated molecular weight of 42.9 kD.

Figure 11. Sephadex G-100 gel filtration chromatography of pooled β -mannanase fractions obtained from anion exchange chromatography. The column was equilibrated with 10 mM potassium phosphate (containing 0.02% azide) to pH 6.2 prior to sample application. Arrows indicate void and total column volumes.

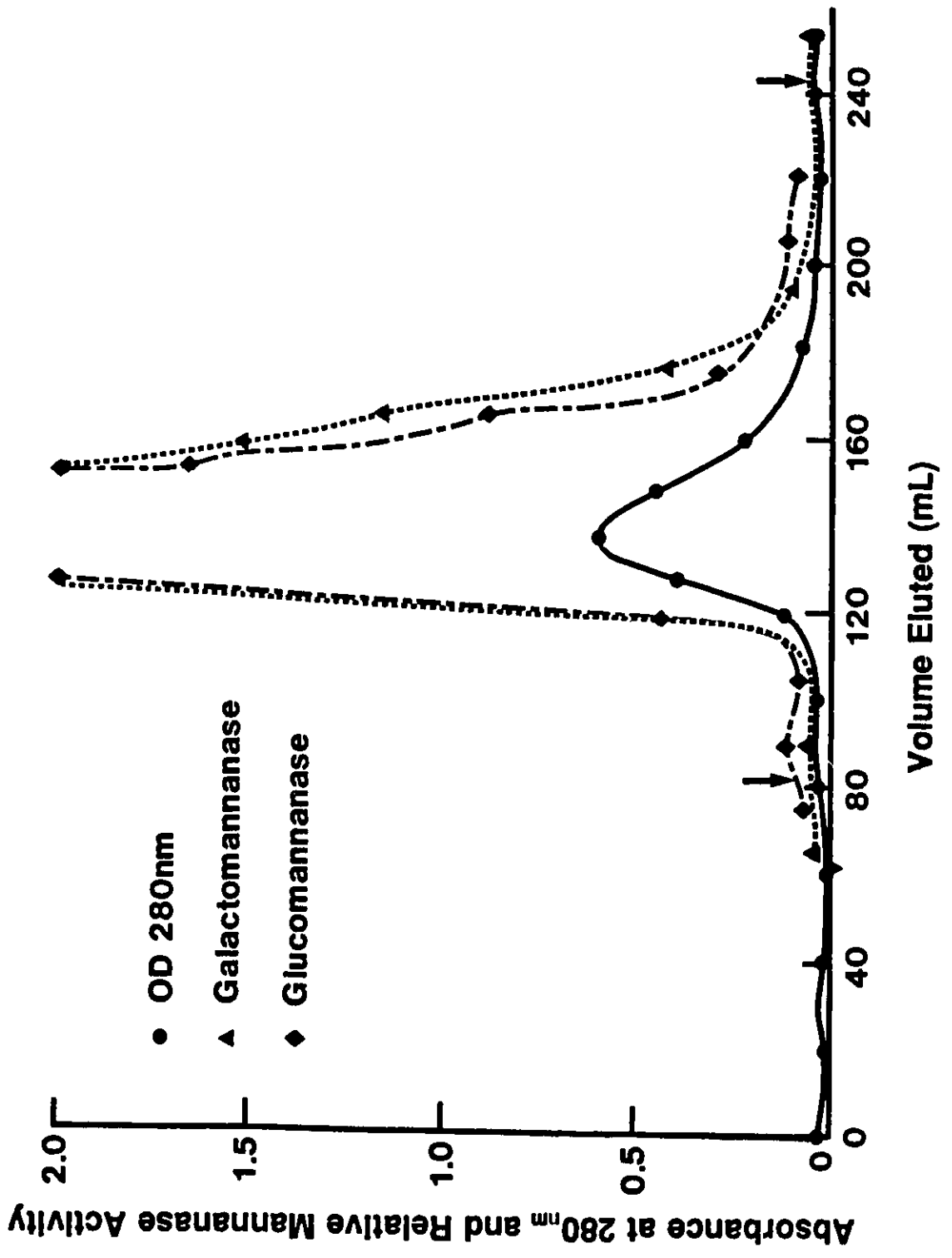

B. Estimation of protein homogeneity and characterization.

The β -mannanase 6.55 was deemed to be pure on the basis that the terminal purification step generated a preparation which exhibited a single band when subjected to SDS-PAGE electrophoresis analysis and whose β -mannanase activity was associated with a protein of pI 6.55. Coomassie blue staining of the profile obtained on a 12% PAGE-SDS homogenous gel revealed a single band with an estimated molecular weight of 42.9 (Figure 12). The isoelectric point of the protein was 6.55. The protein content of the purified enzyme preparation represented 5.6% of the original culture filtrate protein and approximately 15.5% of the initial β -mannanase activity (Table 7). The increase in the specific activity towards konjac root powder β -D-glucomannan, locust bean gum β -D-galactomannan, pine glucomannan and guar gum β -D-galactomannan relative to the original filtrate was 2.81, 2.82, 1.82 and 1.23 fold respectively.

For the purposes of comparison, some of the physicochemical characteristics of β -mannanase 6.55 and other fungal β -mannanases are summarized in Table 9.

C. Substrate specificity.

As previously mentioned, during purification of β -mannanase 6.55 from the crude culture filtrate, a variety of potential substrates were employed. As purification of β -mannanase 6.55 proceeded, the ability of component proteins to hydrolyze p-nitrophenol- β -D-mannopyranoside diminished (Table 8). This observation suggested that β -mannanase 6.55 was an endomannanase incapable of hydrolyzing mannobiose and perhaps other

Figure 12. Coomassie blue stained SDS PAGE gel (12% PAGE Mini-PROTEAN Ready Gel, BioRad, Richmond Calf.). Lane 1) protein standard kit (protein and molecular weight in kDaltons listed); Lane 2) isolated β -mannanase 6.55.

Phosphorylase b (97.4)-
Bovine serum albumin (66.2)-
Ovalbumin (43)-

Carbonic anhydrase (31)-

Soybean trypsin inhibitor (21.5)-

Lysozyme (14.4)-



Lane 1 2

TABLE 9. Characteristics of isolated fungal β -mannanases

Source	Mwt (KDa)	pI	pH optimum	Thermostability (optimum) °C	References
<i>Aspergillus niger -oryzae.</i>	42± 2	4.1	3 - 3.8	50% Activity remaining after 3 h at 70°C (65°C)	Eriksson and Winell 1968
<i>Aspergillus niger</i>		4.1	3.6	Stable for at least 1 h below 60°C (80°C, 10 min)	Yamazaki et al., 1976
<i>Aspergillus tamarii</i>	53± 1	NA	4.8	80% activity remaining after 1 h at 55°C	Civas et al., 1984
<i>Penicillium purpurogenum</i> No.618	57	4.1	5.0	Stable for 30 min below 65°C, (70°C)	Park et al., 1987
<i>Polyporus versicolor</i>	44.7	4.6	5.5	(65°C)	Johnson et al., 1990
	43.6	4.5	5.6	(65°C)	
	57.5	4.25	5.5	(65°C)	
	33.9	3.75	5.5	(65°C)	
<i>Rhizopus niveus</i>	NA	NA	5.5	(40°C) 40% of original activity remaining after 30 min at 50°C	Hashimoto and Fukumoto 1969
<i>Thielava terrestris</i> NRRL 8126	52	NA	4.5	(65°C)	Araujo and Ward 1990d
	30	NA	5.5	(70°C)	
	55	NA	5.0	(75°C)	
	89	NA	5.5	(75°C)	
<i>Trichoderma harzianum</i> E58	42.9± 4	6.55	5.6	60% original activity remaining after 2 hours at 50°C (55 - 65°C, substrate dependent)	This work
<i>Tyromyces palustris</i>	61	3.45	3.5 - 3.8	Completely inactivated after 15 minutes at 80°C (75°C)	Ishihara and Shimizu 1980

NA - data not available.

small mannose oligomers. A study of the hydrolysis of β -mannans and small manno-oligomers was carried out to test this hypothesis.

The following substrates were treated with purified β -mannanase 6.55 under optimum conditions for 30 minutes: mannose, mannobiose, mannotriose, and mannotetrose. In addition 1% (w/v) of each of the following β -D-mannans were incubated for 20 hours with β -mannanase 6.55: locust bean gum β -D-galactomannan, konjac root powder β -D-glucomannan, guar gum β -D-galactomannan, and pine β -D-glucomannan. Aliquots of each reaction mixture were subjected to thin layer chromatography in a solvent system which permitted clear resolution of mannose and higher mannose oligomers (Figure 13). In no case was the release of free mannose detected nor were hydrolytic or transmannosidase products detected in reaction mixtures containing mannobiose, mannotriose, or mannotetrose. In separate experiments, enzyme reaction mixtures of 1% (w/v) locust bean gum β -D-galactomannan or 1% (w/v) konjac β -D-glucomannan were incubated for 20 hours and aliquots removed at intervals were subjected to TLC analysis. Neither mannose nor glucose were among the hydrolysis products detected in any of these β -mannan aliquots. The hydrolysis profiles of the mannans and the inability of the enzyme to degrade small oligomers suggest that the isolated protein is a β -D-endomannanase active on manno-oligosaccharides that are 5 or more subunits in length.

In subsequent experiments, several plant polysaccharides that contained β ,1-4 linkages and monosaccharide components that are frequently encountered in natural environments where β -D-mannans are found, were tested for their ability to serve as substrates for β -mannanase 6.55. The addition of the enzyme to either aspen or birch

Figure 13. Thin layer chromatography analysis of β -mannanase treated materials. Columns from left to right are ; standards M1 - mannose , M2 - mannobiose, M3 -mannotriose, M4 - mannotetraose, C2 - cellobiose, uLB - untreated locust bean gum β -D-galactomannan, tLB - enzyme treated locust bean gum β -D-galactomannan, uK - untreated konjac root powder β -D-glucomannan, tK - enzyme treated konjac root powder β -D-glucomannan, uP - untreated pine glucomannan, tP - enzyme treated pine glucomannan, uG - untreated guar gum β -D-galactomannan, tG - treated guar gum β -D-galactomannan.

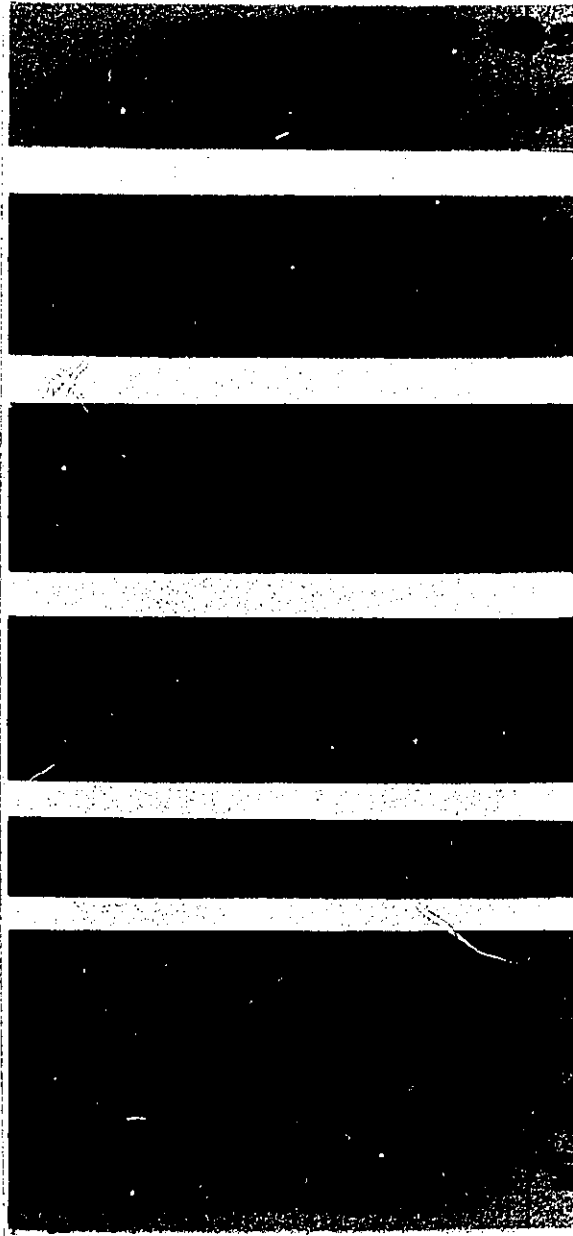

xylans, using standard assay techniques (i.e. 30 min, 50° C, pH 4.8), did not result in detectable release of reducing groups. In addition, β -mannanase 6.55 did not appear to possess detectable β -xylobiase or α -galactosidase activity.

In separate experiments, β -mannanase 6.55 was unable to hydrolyze larchwood or oat spelts xylan even after 20 hours incubation at 40° C. Neither Avicel, CMC, nor Solka floc degradation was detected by TLC or reducing sugar analysis after 20 hours (40° C) incubation with the enzyme. Moreover, the enzyme was inactive on yeast α -mannan. By contrast, approximately 30% of the total reducing sugars present in the β -mannans locust bean gum, konjac β -D-glucomannan, and pine β -D-glucomannan were released after 20 hours incubation, and 14% of the carbohydrate in a spruce lignin carbohydrate complex was released by the enzyme. Although the enzyme did not release detectable levels of reducing groups from pine sawdust, an increase in reducing sugars was detected in the spruce sawdust enzyme reaction mixtures after 20 hours incubation at 40° C. These results are summarized graphically in Figure 14. The above observations are consistent with the endo-mannanolytic nature of β -mannanase 6.55.

D. *The kinetic parameters of T. harzianum E58 β -mannanase 6.55.*

The kinetic parameters of β -mannanase 6.55 were determined for the following β -D-mannan substrates: guar gum β -galactomannan, locust bean gum β -D-galactomannan, pine β -D-glucomannan, and konjac root powder β -D-glucomannan. In addition, the physiological coefficient (v_{\max}/K_m), a term which relates the binding affinity and catalytic rate was determined for each of these substrates.

Figure 14. The substrate specificity of pure β -mannanase. Treated samples (25 mg substrate) were incubated for 20 hours (40°C) with 0.1 Units of glucomannanase activity.

SUBSTRATES

CELLULOSE

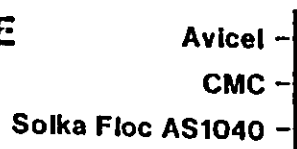

MANNAN

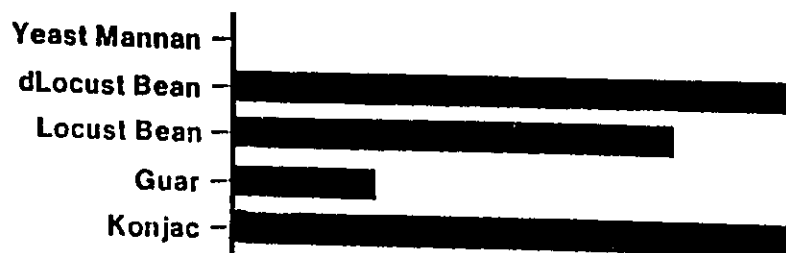

XYLAN

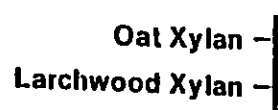

WOOD

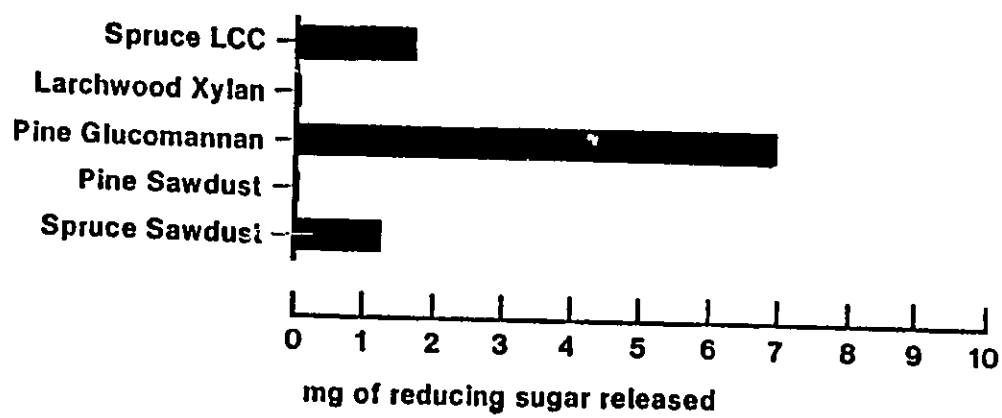

In Figure 15, the effect of substrate concentration on the specific enzyme activity is depicted. Specific activity values for locust bean gum β -D-galactomannan, konjac root powder β -D-glucomannan, and pine β -D-glucomannan were similar for substrate concentrations ranging from 0.001 - 0.075 mg/mL. In contrast, the specific activity of the enzyme towards guar gum β -D-galactomannan was less than half the value determined for the other substrates over this range. At substrate concentrations above 1 mg/mL, the specific activity of the enzyme towards locust bean gum β -D-galactomannan was significantly greater than that calculated for the other substrates. The relationship between substrate concentration and specific enzyme activity appeared to be similar for the two β -D-glucomannans. However, the specific activity of the enzyme towards locust bean gum β -D-galactomannan was greater than the activity towards guar gum β -D-galactomannan and presented a different profile over the substrate concentration range tested (0.001 - 5 mg/mL).

Lineweaver-Burk plots were generated from the above data and K_m and v_{max} values for each substrate were determined. Depending on the substrate used, great variability in K_m values was observed while v_{max} values were more consistent (Table 10). Relative activity, which was arbitrarily set at 100 for locust bean gum β -D-galactomannan, was greatest for the konjac root powder β -D-glucomannan substrate. This situation occurred principally because of the low K_m value indicating that, of the substrates tested, β -mannanase 6.55 had the highest affinity for this glucomannan. Although hydrolysis of guar gum mannan, a highly branched β -D-galactomannan, displayed the highest calculated v_{max} value (catalytic rate), the enzyme had the least

Figure 15. The effect of substrate concentration on the rate of β -D-mannan hydrolysis by *Trichoderma harzianum* β -mannanase 6.55.

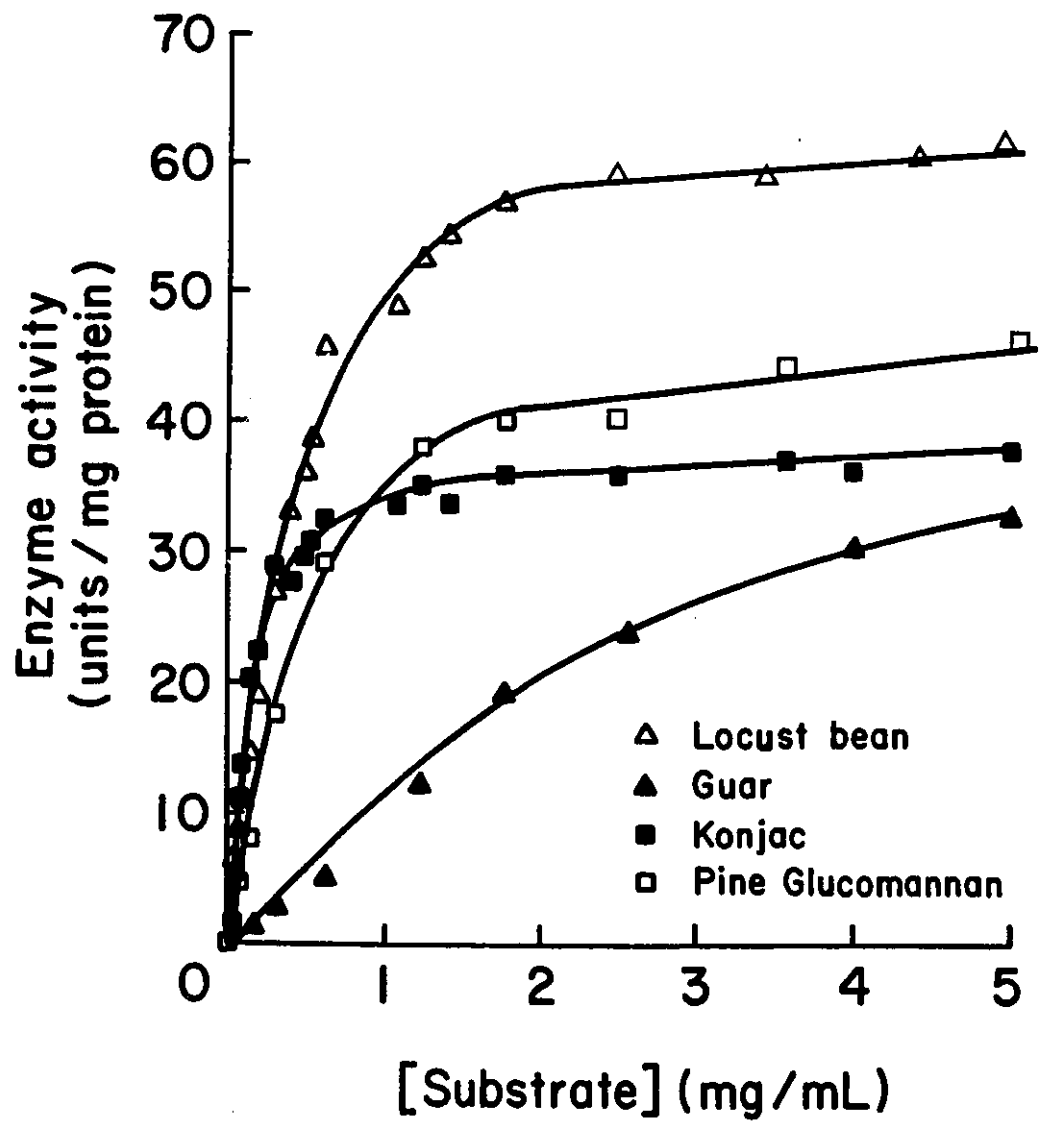

Table 10. Kinetic parameters of *Trichoderma harzianum* E58 β -mannanase 6.55 ^a

Substrate	K_m (mg/mL)	V_{max} (μ mol/min/mg protein)	V_{max}/K_m	Relative Activity ^b
Locust bean gum β -D- galactomannan	0.62	76.7	124.6	100.0
Guar gum β -D- galactomannan	8.00	80.0	10.0	8.0
Pine β -D- glucomannan	1.17	76.9	65.9	53.0
Konjac root powder β -D-glucomannan	0.35	62.5	176.4	142.0
Deacetylated Konjac β -D-glucomannan	0.26	27.3	104.1	83.0

^a Activity was determined by using the Nelson-Somogyi assay to measure the μ moles of reducing sugars released from the substrate per minute at 50 ° C (pH 4.8, 25 mM NaAcetate) during a 30 minute assay.

^b V_{max}/K_m relative to the substrate used for enzyme production (Locust bean gum).

affinity for this substrate. The calculated physiological coefficient (v_{\max}/K_m), an indicator of the overall efficiency of the enzyme, was 17 to 6.5 fold less for guar gum β -D-galactomannan than for values calculated for pine β -D-glucomannan, konjac root powder β -D-glucomannan, and locust bean gum β -D-galactomannan.

E. *Substrate side-groups and enzyme activity.*

Most β -mannans are complex heteropolysaccharides that contain galactose and/or acetyl side groups along their main mannan or glucomannan chain. These side groups can effect the efficiency of the enzyme towards its target substrate, the mannose linkages within the main chain. The possible effect of galactose side groups was studied by comparing the activity of the enzyme towards two β -galactomannans that varied in the number of galactopyranosyl substituents. The lower specific activity of the enzyme (Table 8) and the lower relative activity (Table 10) towards β -D-galactomannan from guar gum compared with β -D-galactomannan from locust bean gum, which is a less substituted galactomannan, suggest that the number of galactose side groups occurring along the mannan chain affects the ability of the enzyme to hydrolyze β -mannan.

The possible effect of acetylation was studied by comparing the activity of the enzyme towards deacetylated konjac β -D-glucomannan and untreated or normal konjac β -D-glucomannan. The specific activity of the enzyme towards deacetylated konjac β -D-glucomannan (0.5% w/v) was 40% lower than the specific activity of the enzyme for acetylated (normal) konjac β -D-glucomannan. While deacetylation of this substrate had little effect upon the affinity of the enzyme, a decrease in the v_{\max} term was observed along with a concomitant decrease in relative activity (Figure 16; Table 10).

Figure 16. Lineweaver-Burk plot for *Trichoderma harzianum* β -mannanase 6.55 active on konjac and deacetylated konjac β -D-glucomannan. The velocity (rate of hydrolysis) was expressed as units/mg protein. For each data set, the linear reciprocal plot was generated using substrate concentrations within approximately $(0.2 \text{ to } 2)K_m$ and is indicated on the graph by the solid lines.

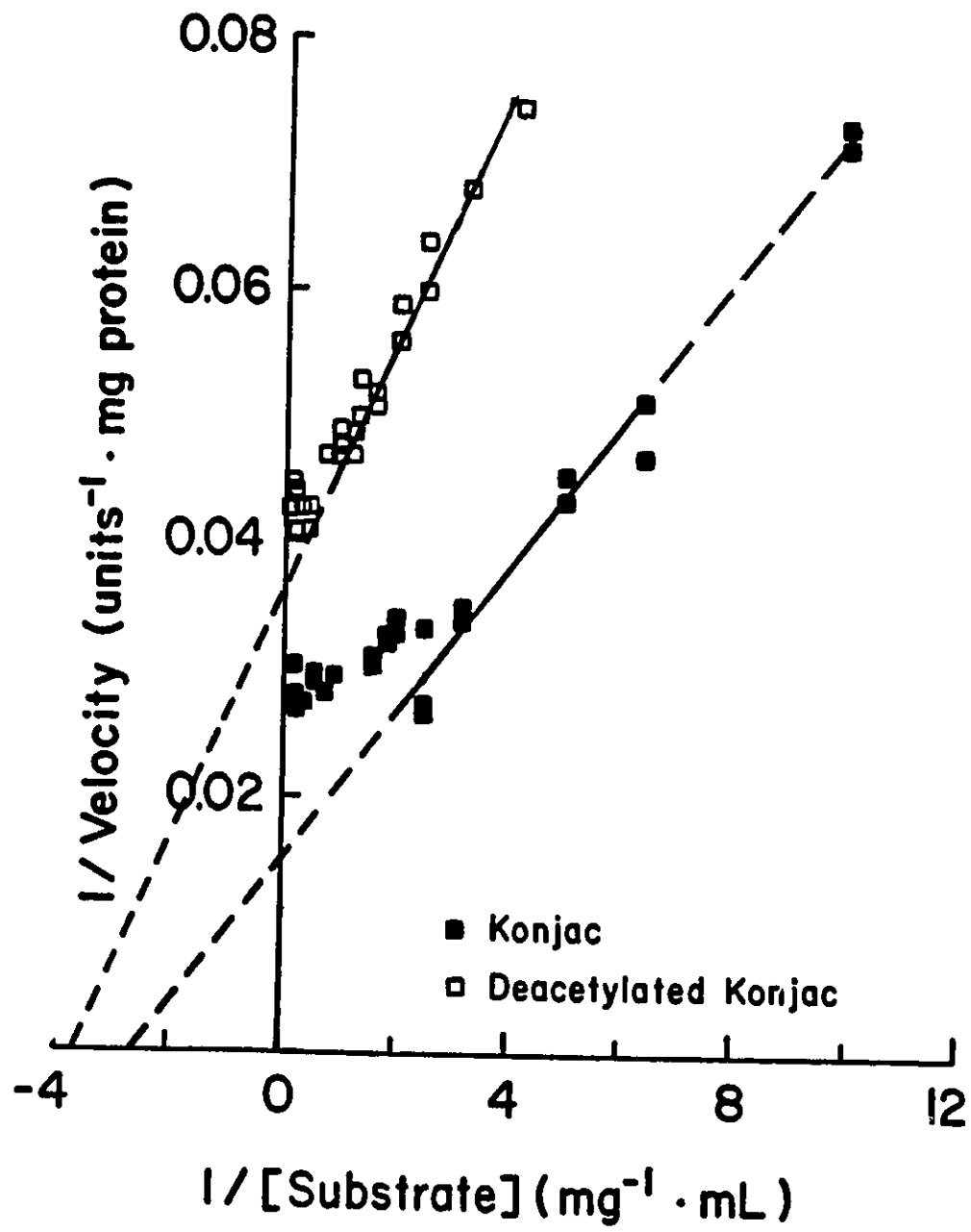

F. *The effect of temperature on enzyme activity.*

The effect of temperature on purified β -mannanase 6.55 was determined across a broad range from 25 to 75°C (Figure 17). Hydrolysis of locust bean gum had a clear optimum temperature of 65°C, while hydrolysis of pine β -D-glucomannan appeared to have an optimum temperature of 55°C. Activity was detected across the entire temperature range and the optimum was between 55 - 65°C for all four β -mannans (Figure 17).

In separate experiments, the thermostability of the enzyme activity was determined and was found to be the same for all four assay substrates (Figure 18). At temperatures below 70°C, following an initial rapid decrease in activity with time, the rate of decrease in activity after pre-incubation at a given temperature was diminished. After 20 minutes at 70°C, 20% of the enzyme activity remained but activity was no longer detected after 45 minutes pre-incubation at 70°C. However, 60% of the activity remained after 2 hours pre-incubation at 50°C (Figure 18).

G. *The effect of pH on enzyme activity*

β -Mannanase 6.55 was active across the pH range from 3 to 9 (Figure 19), with optimal activity occurring near pH 6.0. Like the thermostability of enzyme activity, the optimum pH for enzyme activity did not vary with the assay substrate. However, the type of buffer used to maintain a given pH did affect activity. When β,β -Dimethyl-glutaric acid was used as the buffer, enzyme activity was 10 - 20 % less than that recorded at the same pH in a sodium acetate buffered solution. The highest activity levels were found

Figure 17. The effect of temperature on β -D-mannan hydrolysis by *Trichoderma harzianum* β -mannanase 6.55.

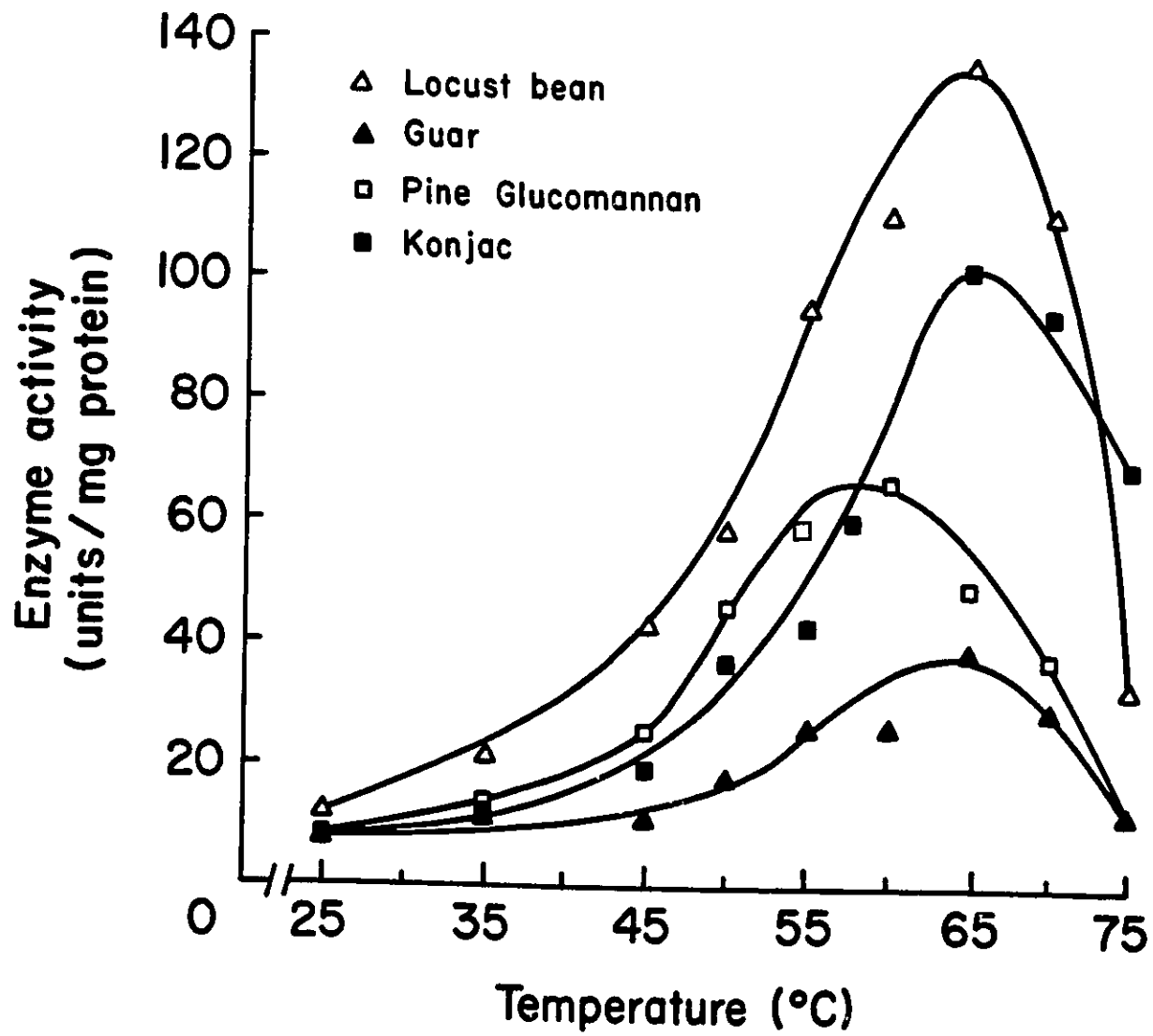

Figure 18. The thermostability of *Trichoderma harzianum* β -mannanase 6.55. The enzyme was pre-incubated at a given temperature for varying lengths of time prior to the addition of the assay substrate. Substrate hydrolysis was measured by the Nelson-Somogyi reducing sugar assay (0.5% (w/v) locust bean gum β -D-galactomannan, pH 4.8, 50°C, 30 min). Activity is expressed relative to the activity of untreated enzyme.

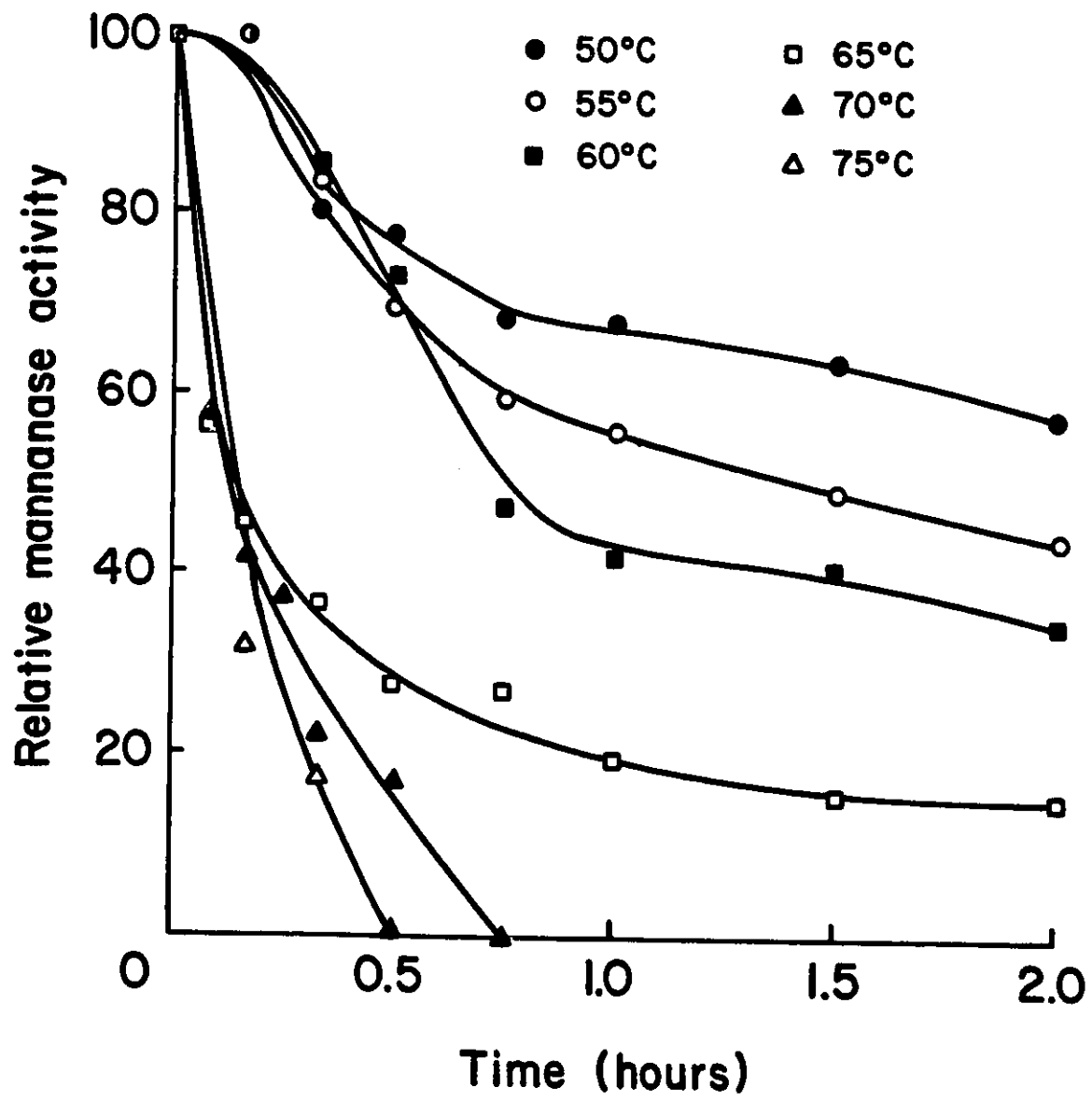
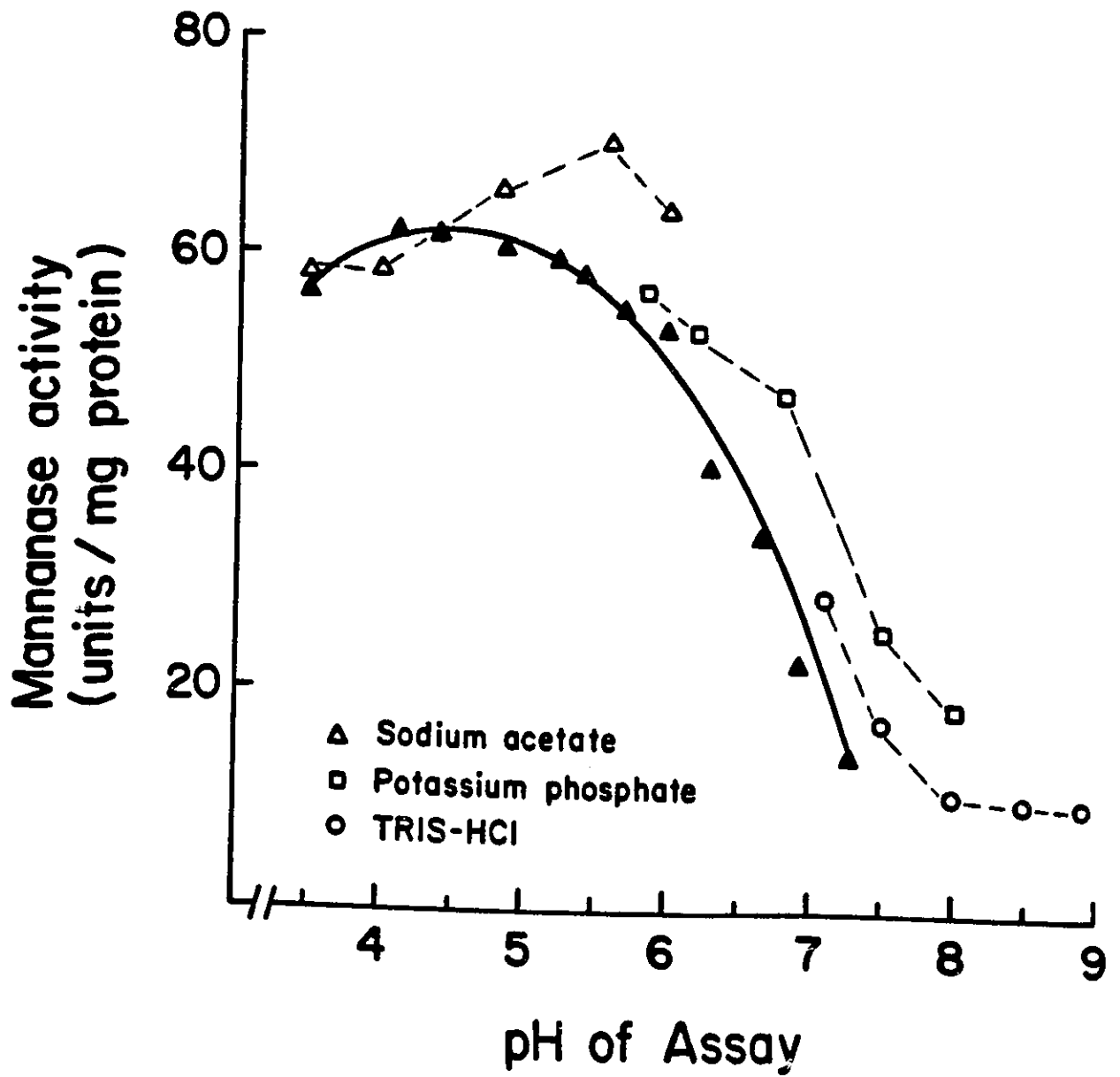

Figure 19. The effect of pH upon *Trichoderma harzianum* β -mannanase 6.55 activity. Enzyme activity data determined with a single buffer, β,β -dimethyl-glutaric acid, over the pH range in which the enzyme was most active, was plotted (Δ - Δ). Other buffers (25 mM) employed to cover the full pH range studied are listed on the graph.



when sodium acetate was used as the buffer. When sodium acetate buffer was employed, the optimum pH was 5.6. Regardless of the which buffer was used, 75% of the enzyme activity under optimum pH conditions was maintained over the pH range 3.5 - 6.5 (Figure 19).

H. *Affectors of enzyme activity.*

1. *Proteases.*

The effect of a number of proteases on the activity of purified β -mannanase 6.55 was determined using a mass ratio of protease to enzyme of 5:1 . Konjac β -D-glucomannan and locust bean gum β -D-galactomannan served as substrates. Results are presented in Table 11. The ability of the enzyme to degrade β -D-mannans from both konjac root powder and locust bean gum was unaffected by α -chymotrypsin or trypsin and less than 12% of β -mannanase activity was lost after *Staphylococcus aureus* V8 protease treatment. While pepsin did not the decrease β -galactomannanase activity of the enzyme, approximately 20% of the β -glucomannanase activity of the enzyme was destroyed during pre-incubation with pepsin. Protease K, a protease isolated from fungi, decreased enzyme activity by two-thirds towards both the β -D-glucomannan and the β -D-galactomannan substrates. Although the total activity per mL was decreased by two-thirds, only a 14% decrease in specific activity was observed when the enzyme was pre-incubated with protease K, indicating that much of the hydrolyzed portion of the enzyme is not critical to endo-mannanolytic activity. Similarly, the increase in specific

Table 11. Effect of protease on the activity of β -mannanase 6.55.

Protease Treatment ^a	Relative β -D-Mannanase Activity ^b			
	Galactomannanase		Glucomannanase	
	Relative % Activity	Relative Specific Activity ^c	Relative % Activity	Relative Specific Activity ^c
None	100	100	100	100
Pepsin	103	159	78.5	121
α -Chymotrypsin	99.9	135	104	140
Trypsin	100	117	109	127
Protease K	33.5	86.9	33.3	86.1
<i>Staphylococcus aureus</i> V8 protease	88.8	N.E	93.0	N.D.

^a Mannanase enzyme was treated for 30 minutes (37 ° C) with 500 μ g/mL proteases.

^b After protease treatment enzyme activity remaining was determined as described in the text and expressed as percent activity relative to untreated enzyme.

^c Units enzyme activity divided by mg protein remaining after treatment relative to the specific activity (Units/mg protein) of untreated enzyme.

N.D. Not determined.

activity after α -chymotrypsin and pepsin treatments indicated that these proteases also hydrolyzed portions of the β -mannanase enzyme not directly involved in the activity being measured (Table 11).

2. Metal ions.

The effect of various ions on β -mannanase 6.55 activity is graphically depicted in Figure 20. While none of the metal ions tested enhanced activity varying degrees of inhibition were observed. Concentrations of NaCl up to 450 mM NaCl did not affect the activity of the enzyme towards konjac β -D-glucomannan or locust bean gum β -D-galactomannan. As well, no change in the activity of the enzyme was detected when as much as 100 mM KCl or CaCl₂ was added to the assay medium. The interference of MnCl₂ · 4H₂O with the detection assay did not permit specific determination of its effect on enzyme activity. Addition of up to 20 mM ethylenediamine tetraacetic acid (EDTA) to the β -mannanase assay had no impact upon the measured activity of the enzyme. The order of decreasing inhibition by other tested metal ions was; Hg²⁺ > Fe²⁺ > Cu²⁺ > Zn²⁺ > Co²⁺ > Mg²⁺ (Figure 20).

3. Detergents and solvents.

The effect of various types of detergent upon the activity of β -mannanase 6.55 was studied by the addition of 0 - 2 % (v/v) of the following detergents to the enzyme reaction mixture: Tween 80, Triton X-100, SDS, Zwitterion TM314, or Phemerol chloride. At low concentrations of 0.001 - 0.2% (v/v), the presence of non-ionic (Tween 80, Triton X100), cationic (Phemerol chloride), and zwitter ion detergents in the assay

Figure 20. Influence of metal ions on the hydrolysis of locust bean gum β -D-galactomannan by *Trichoderma harzianum* β -mannanase 6.55 activity. Activity is expressed relative to the activity of enzyme assayed without the addition of metals.

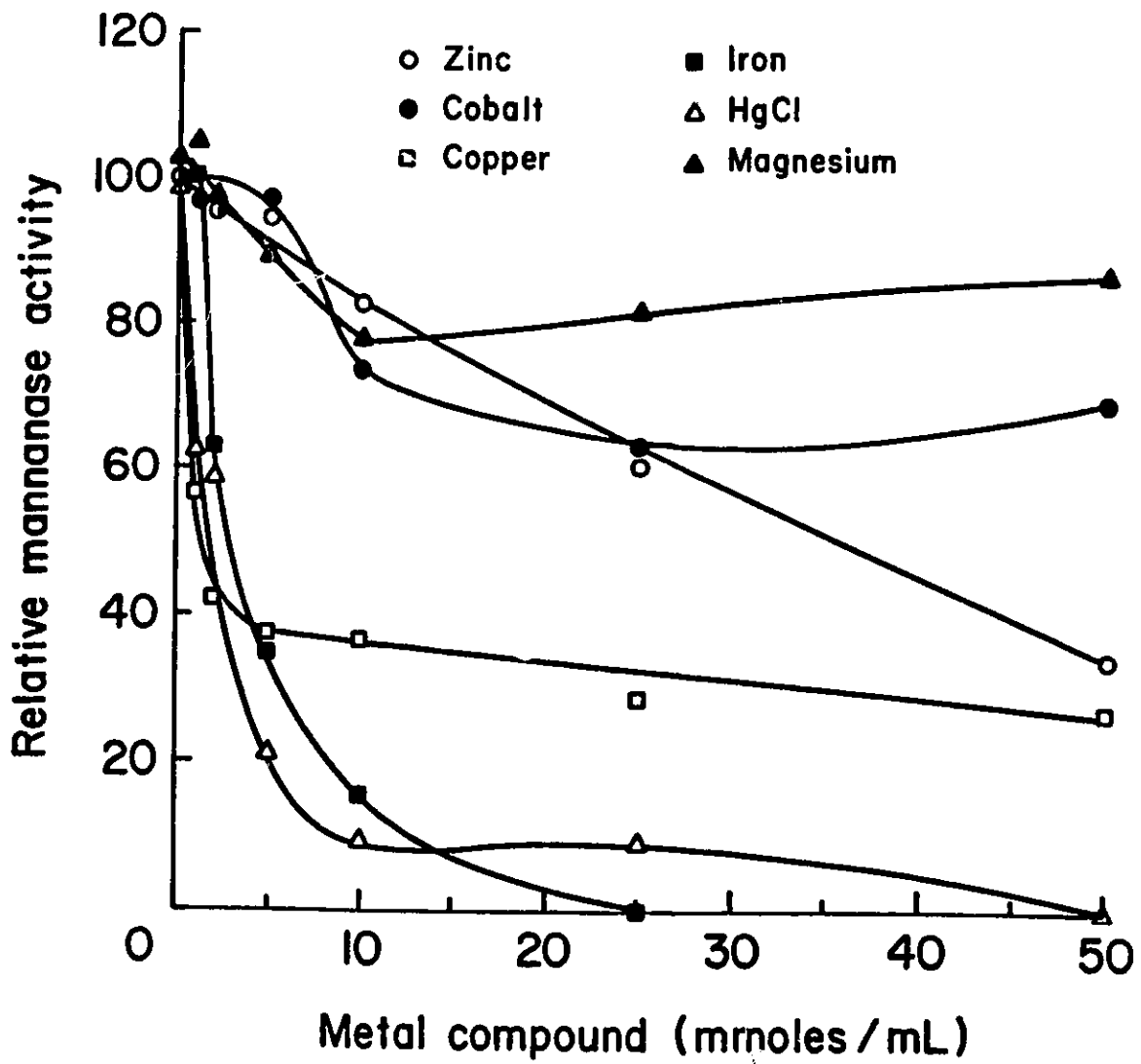

medium increased the level of enzyme activity towards both locust bean gum and konjac root powder β -D-mannans (Figure 21). Within the variation of the assay results, SDS had little effect on the activity of the enzyme. At higher concentrations of phemerol chloride or zwitterion detergent ($>0.2\%$ v/v), relative enzyme activity decreased. All detergents except SDS, increased the variation in the assay itself at concentrations above 0.5% (v/v).

Ethanol and methanol were assayed for their influence on β -mannanase 6.55 activity. The addition of up to 20% (v/v) of either solvent increased the relative activity of the enzyme towards both locust bean gum β -D-galactomannan and konjac β -D-glucomannan. The observed solvent-mediated increase in the relative β -mannanase activity is depicted graphically in Figure 22. Enzyme reaction mixtures containing 40% (v/v) of either solvent exhibited less than 30% of the activity found in reaction mixtures to which no solvent had been added. By contrast, the presence of 10 and 20% (v/v) of either solvent appeared to increase relative β -D-mannanase activity by as much as 80% .

I. *The interaction of T. harzianum E58 β -D-mannanase with non-mannan polysaccharides.*

Since potentially enzyme degradable β -D-mannan linkages invariably occur within a matrix that includes other plant cell wall materials, it was considered important to investigate the action of β -mannanase 6.55 in the presence of various polymers of plant origin. Such investigations were deemed important in order to develop some insight into the potential use of β -mannanase 6.55 in practical applications where other plant material would be present, such as in the enzymatic treatment of wood pulps. Although previous

Figure 21. Influence of detergents on β -mannanase 6.55 activity. Activity is expressed relative to the activity of enzyme assayed in the absence of detergent.

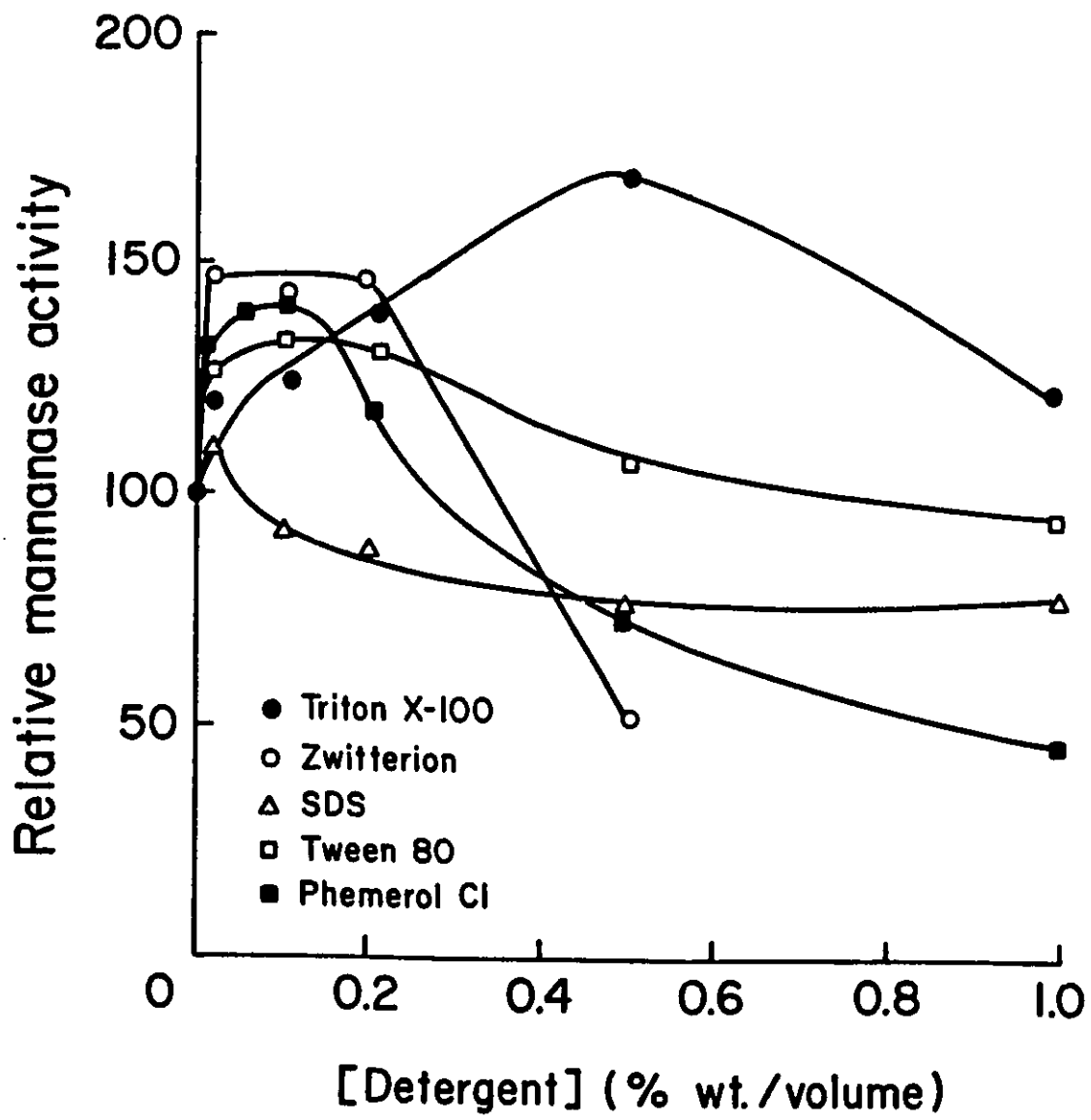
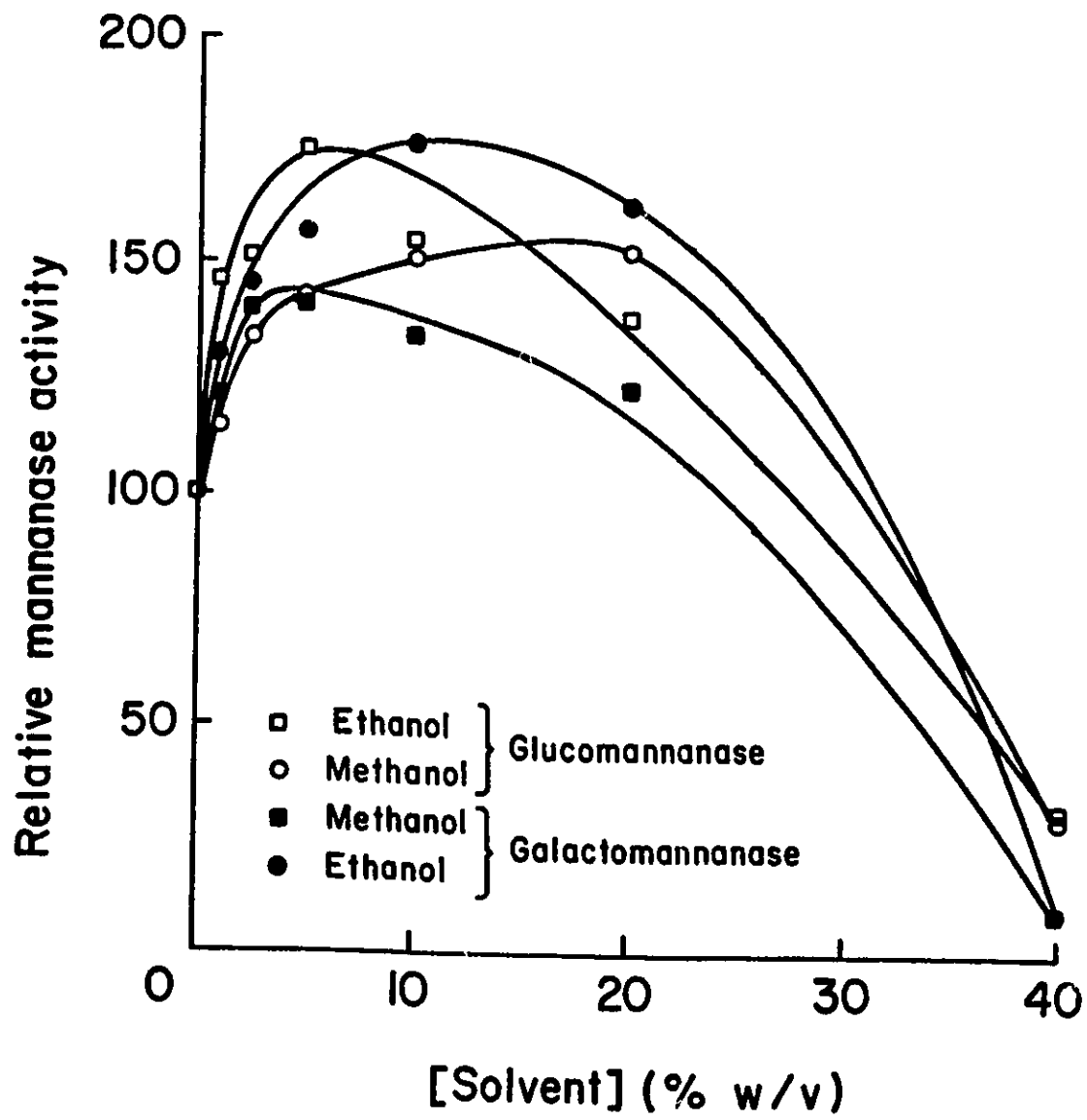

Figure 22. The influence of methanol and ethanol upon the activity of *Trichoderma harzianum* β -D-mannanase 6.55. Activity is expressed relative to the activity of enzyme assayed in the absence of solvent.



studies (Section IV-C), indicated that neither celluloses nor xylans were degraded by β -mannanase 6.55, the possibility that these materials might affect the ability of the enzyme to interact and degrade β -mannans had to be examined.

1. Celluloses.

The effect of the cellulose on the enzyme activity varied with respect to the β -D-mannan substrate used to assay enzyme activity. The presence of 0.5% (w/v) CMC or Solka floc (0.5% w/v) or Avicel (0.2 - 0.5% w/v) in the assay medium did not appear to affect the specific activity of the enzyme towards konjac root powder β -D-glucomannan. In contrast, the specific activity of β -mannanase 6.55 towards locust bean gum β -D-galactomannan appeared to be increased 15 - 20% by the presence of any one of these three celluloses in the reaction mixtures.

The effect of Avicel upon the kinetic parameters of β -mannanase 6.55 with respect to locust bean gum β -D-galactomannan was studied (Figure 23; Table 12). The presence of 0.1% (w/v) Avicel in the assay medium had little effect on the overall efficiency of the enzyme (v_{\max}/K_m) towards the target substrate. While the apparent K_m and v_{\max} values of the enzyme for locust bean gum β -D-galactomannan were increased in the presence of 1.0% Avicel, the overall efficiency of enzymatic hydrolysis was approximately half that observed in the absence of Avicel (Table 12).

To determine if β -mannanase 6.55 formed an association with non-target polysaccharides and to see if such an association affected the activity of the enzyme, purified β -mannanase 6.55 was mixed with various concentrations of Avicel and Solka floc. Following incubation, the cellulose was removed by centrifugation, the resulting

Figure 23. Lineweaver-Burk plot for *Trichoderma harzianum* β -mannanase 6.55 activity on locust bean gum β -D-galactomannan in the presence of Avicel PH101 or larchwood xylan. The "non-mannan" polysaccharide added were; a) None - locust bean alone, b) 0.25% (w/v) Larchwood xylan, c) 0.1% (w/v) Avicel PH101, d) 1.0% (w/v) Avicel PH101. The velocity (rate of hydrolysis) was expressed as units/mg protein. For each data set, the linear reciprocal plot was generated using substrate concentrations within approximately $(0.2 \text{ to } 2)K_m$ and is indicated on the graph by the solid lines.

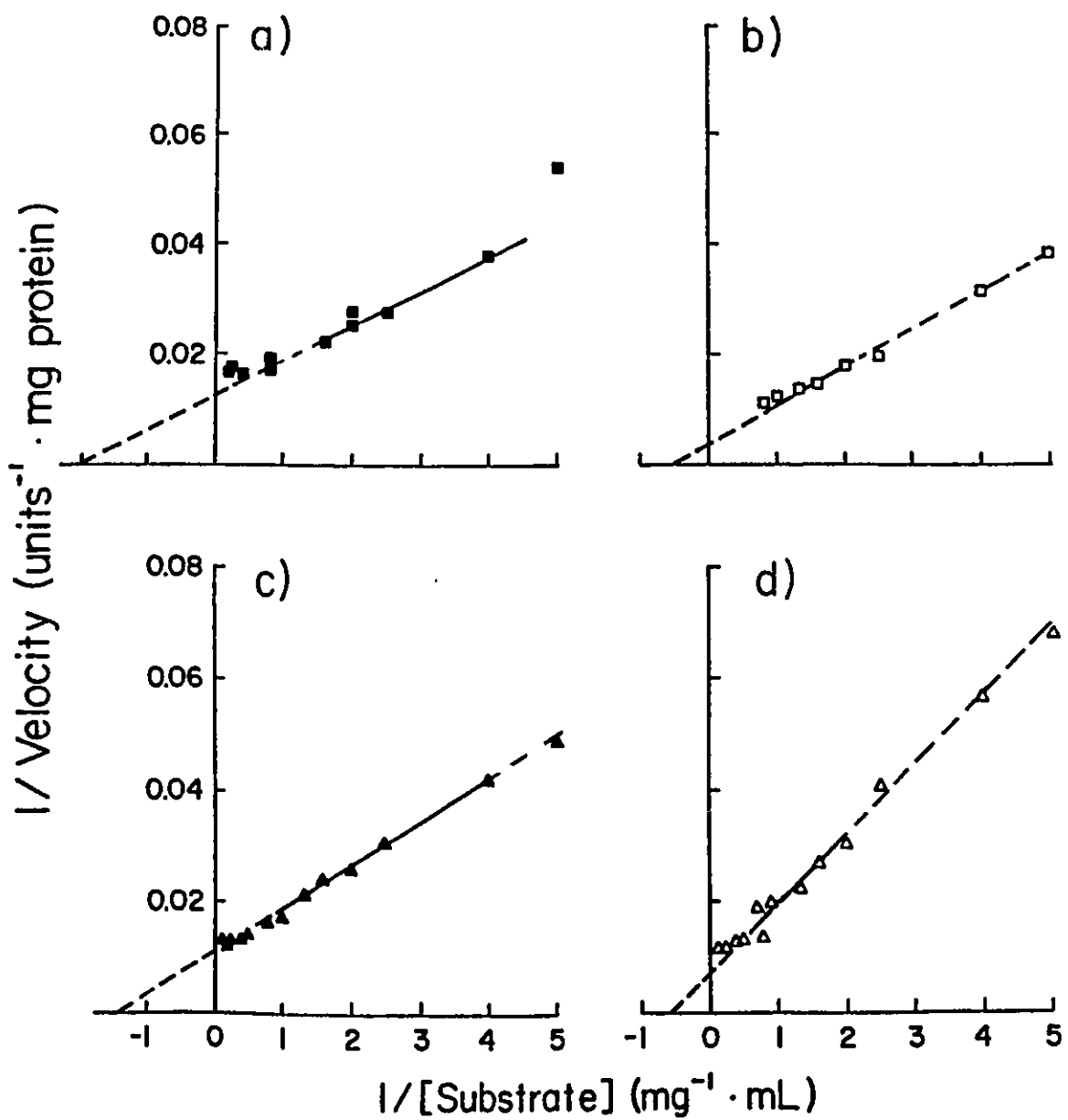

Table 12. The effect of the presence of Avicel and xylan on the kinetic parameters of β -mannanase 6.55 towards locust bean gum β -D-galactomannan.

Assay Substrate	K_m (mg/mL)	V_{max} (μ mol/min/mg protein)	V_{max}/K_m	Percent Relative Activity ^a
Locust bean gum β -D-galactomannan (alone)	0.601	81.3	137	100
Locust bean gum β -D-galactomannan + 0.1 % (w/v) Avicel	0.700	86.8	124	90.5
Locust bean gum β -D-galactomannan + 1.0 % (w/v) Avicel	1.91	138	72.1	52.7
Locust bean gum β -D-galactomannan + 0.25 % (w/v) larchwood xylan	2.00	275	138	101

^a V_{max}/K_m relative to the value for the control (locust bean gum β -D-galactomannan alone).

pellet washed twice and the initial supernatant fraction, as well as the supernatant fractions obtained from each wash, and the insoluble cellulose fractions were assayed for β -mannanase activity using locust bean gum β -D-galactomannan (Table 13). When the enzyme was pre-incubated with 0.2%, 0.5% and 1.0% (w/v) Avicel, β -mannanase activity associated with the insoluble cellulose, and a significant portion could not be removed by washing. The greater the concentration of Avicel, the greater the proportion of total activity associated with the insoluble cellulose. In all cases, the total enzyme activity initially added to a reaction mixture could be accounted for by summing the various subfractions of each Avicel-enzyme mixture (Table 13).

In similar experiments with Solka floc, β -mannanase activity was found to be associated with the insoluble Solka floc fraction. However, only 74.0%, 84.7 % and 87.2% of the total enzyme activity pre-incubated with 1.0%, 0.5% and 0.2% (w/v) Solka floc respectively was recovered in the supernatant fraction and the insoluble Solka floc fractions. As with Avicel pre-incubations, the relative activity recovered in the initial supernatant fraction decreased with increasing concentrations of Solka floc. Unlike Avicel pre-incubation treatments however, the proportion of the relative activity associated with 0.5% (w/v) Solka floc did not differ from the amount associated with 1.0% (w/v) Solka floc (Table 13).

Table 13. The association of β -mannanase activity with celluloses.

Concentration of Cellulose (%w/v)	Relative Percent Mannanase Activity ^a	
	Activity associated with washed cellulose	Activity not associated with washed cellulose
Control (0%)	N.A.	100
Avicel PH101 (0.2%)	51.6	45.3
Avicel PH101 (0.5%)	58.7	37.9
Avicel PH101 (1.0%)	84.1	26.6
Solka floc AS1040 (0.2%)	44.1	43.1
Solka floc AS1040 (0.5%)	55.9	30.8
Solka floc AS1040 (1.0%)	55.3	18.7

^a Enzyme activity of *Trichoderma harzianum* E58 β -mannanase 6.55 was determined after 30 minutes preincubation with cellulose at 30 ° C. Activity is expressed as a percent of the activity of the enzyme (Units/mg protein) after preincubation at 30 ° C for 30 minutes in the absence of cellulose. Activity was measured using the Nelson Somogyi assay with locust bean gum β -D-galactomannan (0.5% w/v) as the substrate.

2. Xylans.

The ability of β -mannanase 6.55 to associate with xylans was also investigated. The enzyme was pre-incubated with insoluble fractions of 0.5%, 0.2% and 0.1% (w/v) larchwood, birch, and aspen xylans. The supernatant fraction contained 65 - 80% of the total β -mannanase activity initially added to reaction mixtures. Unlike the cellulose studies, the remaining β -mannanase activity was recovered in the wash fractions and less than 10% of the total activity was associated with the insoluble xylans after two washings. In separate experiments, the effect of various xylans on β -mannanase activity was also studied. The presence of 0.5% (w/v) birch xylan in the assay medium did not affect the specific activity of the enzyme towards locust bean gum β -D-galactomannan or konjac β -D-glucomannan. However, the presence of 0.1% (w/v) or 0.2% (w/v) pine xylan decreased the activity of the enzyme towards pine glucomannan by 25% and 30% respectively. The addition of 0.5% (w/v) larch xylan to the assay medium did not affect the specific activity of the enzyme for locust bean gum β -D-galactomannan or konjac β -D-glucomannan. However, the presence of 0.25% larch xylan increased the apparent K_m and v_{max} of the enzyme for locust bean gum without increasing the overall relative activity of the enzyme for the target substrate (Figure 23; Table 12).

J. *The interaction of T. harzianum E58 β -mannanase with other hemicellulases.*

Since β -mannans are often found within a complex matrix of polysaccharides and/or lignocellulosics, the ability of β -mannanase to interact with other hemicellulases may be important in the removal of hemicellulose from such matrices. As a preliminary

assessment of the possible interaction of β -mannanase 6.55 with other hemicellulases, enzymatic treatment of black spruce lignocellulose complex (LCC) by β -mannanase with and without xylanase, acetyl xylan esterase and the α -galactosidase was performed. Results are presented in Table 14. An additive effect upon the amount of reducing sugar equivalents released from the substrate was observed when β -mannanase and endoxylanase were co-incubated. Even at an enzyme loading of 400 Units/mg substrate, degradation of the LCC by the α -galactosidase enzyme was limited. The α -galactosidase enzyme did not act synergistically with any of the other tested enzymes. While less than additive reducing sugar release was achieved when β -mannanase and acetyl xylan esterase were co-incubated, when all four enzymes were used together a 66.7% increase above calculated levels was attained (Table 14), emphasizing the complexity of the interactions between lignocellulose matrices and hydrolytic enzymes.

Table 14. The ability of extracellular hemicellulase enzymes to release reducing sugars from black spruce lignin carbohydrate complex.

Enzyme Treatment	Percent Total Carbohydrate Liberated ^a	Observed Hydrolysis ^b (μg reducing sugars released)	Calculated Hydrolysis (Based on additive effect)	Percent Difference (between observed and calculated)
β-D-mannanase	6.6	164	—	—
β-D-xylanase	1.7	43.5	—	—
α-D-galactosidase	0.28	7.1	—	—
acetyl xylan esterase	0.38	9.5	—	—
β-D-mannanase + β-D-xylanase	8.6	216	207	+4.0%
β-D-mannanase + α-D-galactosidase	7.3	181	171	+5.8%
β-D-mannanase + acetyl xylan esterase	6.8	171	174	-1.4%
β-D-mannanase + β-D-xylanase + α-D-galactosidase + acetyl xylan esterase	14.9	374	224	+66.9

^a Percent total carbohydrates liberated is the percentage of reducing groups liberated by the enzyme treatment relative to the total carbohydrate of the lignin carbohydrate complex measured by the phenol sulfuric acid assay.

^b 0.5% (w/v) Black spruce lignin carbohydrate complex was enzyme treated at 50° C for 2 hours as described in the text. Increase in reducing potential was measured by the Nelson-Somogyi assay using mannose as the sugar standard.

DISCUSSION

To effectively interpret the data arising from this study as well as that available in the literature, one must first consider the methods used to detect and measure β -mannanase activity.

I. Detection and Determination of β -Mannan Degradation

A. *The role of model substrates.*

Unlike the relatively straight forward measurement and detection of enzyme catalyzed reactions occurring in solutions with simple low molecular weight substrates and/or products, enzyme hydrolysis of specific chemical bonds found in heterogenous matrices is more difficult to monitor. This is particularly evident with lignocellulosic materials, where a great diversity of composition and structure, according to origin, is encountered. To monitor specific hydrolytic enzyme action in such complex, heterogenous materials, it is often useful to employ a model substrate containing one or more features of the target component that is absent in the other components within the mixture or matrix. For example, in the work presented in this thesis, plant lignocellulosics are the matrix in which the target substrates, β -D-galactomannans and β -D-glucomannans, are enmeshed while cellulose and xylan carbohydrate complexes are the other components found in the matrix. Therefore, appropriate model substrates would possess, in sufficiently high concentrations to allow detection of hydrolysis, one or more of the following linkages; mannopyranosyl-mannopyranosyl, mannopyranosyl-glucopyranosyl or mannopyranosyl-galactopyranosyl. Ideally model substrates should also

be readily and cheaply available in large quantities with little or no batch to batch variation in composition. The failure of mixtures of crude plant lignocellulosics and wood β -D-mannans to meet these criteria was discussed previously, (Introduction - Section IV.A.1 Classification and detection of β -mannanase capable of degrading wood mannans). However, β -D-galactomannan from guar gum, β -D-galactomannan from locust bean gum, and konjac root powder β -D-glucomannan fulfilled the above criteria, and were chosen as model substrates in this study.

Both locust bean gum and guar gum β -D-galactomannan contain β -linked mannopyranosyl-mannopyranosyl bonds similar to those found in the main chain of wood hemicellulose β -galactoglucomannan and β -D-glucomannan components. In addition, the galactopyranosyl-mannopyranosyl linkages found in these two β -D-galactomannans is the same type as that found in lignocellulosic β -D-galactoglucomannans. The galactopyranosyl substituent groups are α -1,6 linked to the mannopyranosyl units of the main chain of the polysaccharide in both locust bean gum and guar gum β -D-galactomannan as well as in lignocellulosic β -D-galactoglucomannans. For the current study, locust bean gum was chosen over guar gum β -D-galactomannan as a model substrate for routine β -mannanase assays because the proportion of galactopyranosyl to mannopyranosyl in locust bean gum was closer to the ratio found in softwood β -D-galactoglucomannans than that found in guar gum β -D-galactomannan.

The ability of an enzyme to release reducing sugars or solubilize β -D-galactomannan does not necessarily mean that the activity of the enzyme will result in significant degradation of the β -D-galactoglucomannans and/or the β -D-glucomannans found in lignocellulosics. For example, α -galactosidase (EC 3.2.1.22) may be capable

of releasing reducing sugars in the form of galactopyranosyl residues from locust bean gum β -galactomannan but would be incapable of hydrolyzing the mannopyranosyl linkages in the main chain of any β -D-mannan. Furthermore, the presence of glucopyranosyl units within the main chain of a β -D-glucomannan or β -D-galactoglucomannan could affect the affinity of a given β -mannanase for the substrate and/or the catalytic rate of the reaction. Like wood β -D-glucomannans, konjac root powder β -D-glucomannan does not possess a regular repeating structure nor blocks of cellulose or mannans within its chain (Table 2; Figure 3), (Brownsey *et al.*, 1988, Chanzy *et al.*, 1982; Fengel and Wegner 1983). Therefore, it was decided to include konjac root powder β -D-glucomannan as a model of the β -1,4 glucopyranosyl-mannopyranosyl linkages found in wood β -D-mannans. Since both konjac root powder and wood β -glucomannans are acetylated in their native state (Dea *et al.*, 1977; Hori and Elbein 1985; Sjöström 1981), konjac root powder β -D-glucomannan was also employed as the model substrate to explore the impact of acetyl groups on the enzymatic hydrolysis of β -D-glucomannans.

B. Detection of β -mannanase activity.

When the ability of the nine organisms listed in Table 4 to grow in medium containing 1 % (w/v) β -D-mannan and utilize the substrate was initially monitored, locust bean gum β -D-galactomannan was chosen as the model substrate, rather than konjac root powder β -D-glucomannan, in order to avoid false positives. Locust bean gum β -D-galactomannan lacks glucopyranosyl units within its chain and would therefore be unlikely to undergo partial hydrolysis by any endoglucanase that might be present.

Similarly, to avoid false positives arising from α -galactosidase activity, all preparations with detectable β -galactomannanase activity were also tested for their ability to solubilize β -D-glucomannan. *Aspergillus niger* 207E and *Tyromyces palustris*A 227A were included as positive controls to ensure that the methods used to monitor activity were effective. The other test organisms, whose physiology and production of a variety of extracellular enzymes were already under study at Forintek, were all known to produce extracellular xylanase(s).

Although *Pichia wickerhammi*, *Candida wickerhammi*, *Thielavia* spp., and *Thermoascus aurantiacus* were known to utilize xylan, they were unable to utilize β -mannan (Table 4). This is not surprising. The inability of a single organism to utilize all components in lignocellulose, has been well documented. Furthermore, in nature, the complete decomposition of all the polysaccharides found in lignocellulosics is thought to be the result of the action of successive communities of organisms (Highley 1987; Hudson 1980; Eriksson *et al.*, 1990). Although little or no β -D-galactomannan utilization by *P. wickerhammi*, *C. wickerhammi*, *Theivala* spp., or *Thermoascus aurantiacus* was observed, these organisms were capable of lowering the degree of polymerization of the locust bean gum β -D-galactomannan. This would suggest that although these organisms produced non-specific depolymerizing enzyme(s), they lacked the β -mannan specific enzymes required to sufficiently hydrolyze the substrate. Of the three remaining organisms, *T. harzianum* E58 utilized a higher proportion of the β -D-galactomannan substrate and reduced the degree of polymerization of the residual substrate more than either of the two *P. stipitis* strains (Table 4). Based on the above data, the production of extracellular β -mannanase activity by *T. harzianum* E58 was selected for further study.

C. Measurement of β -mannanase activity levels.

Traditionally, polysaccharidase levels have been determined using assays based upon the release of reducing sugars from polysaccharide substrates. More recently, researchers have used HPLC analysis to quantify and identify the products of cellulose and xylan hydrolysis (Schwald *et al.*, 1988; Senior *et al.*, 1988). Unfortunately, HPLC analysis alone is an impractical ineffective method for monitoring the degradation of β -D-galactomannans or β -D-glucomannans. Unlike xylan and cellulose which are predominately homopolymeric, β -D-mannans are heteropolymers whose hydrolysis results in a complex array of oligomers which have not yet been effectively resolved and identified by HPLC techniques. Furthermore owing to the lack of a complete set of manno-oligomer, galactomanno-oligomer, galactoglucomanno-oligomer and glucomanno-oligomer standards, the products of β -D-galactomannan and β -D-glucomannan hydrolysis cannot yet be quantified by HPLC. Thus, until more information has been obtained regarding the structure of β -D-glucomannans and β -D-galactoglucomannans and the products of their hydrolysis, HPLC analysis will not become a stand alone assay for measuring β -mannanase activity levels. Moreover, as a qualitative assay technique HPLC analysis does not provide information regarding the hydrolytic products of β -D-mannans that cannot be obtained by cheaper less time consuming methods such as TLC analysis. As a consequence, HPLC analysis was not employed as a routine technique for β -mannanase assays and its use was limited to detection of monomeric sugars in this study.

Other methods of quantifying β -D-mannan hydrolysis were considered. Viscosity assays are based upon differential rheological properties which accompany polymer hydrolysis. Although viscosity assays are sensitive to endopolysaccharidase activity

regardless of background sugar levels, their routine use for monitoring samples of unknown activity is limited. Disadvantages of this technique include; i) Factors such as temperature alter the viscosity of a solution independent of enzyme activity. Therefore, reproducible results require precise temperature control and either large sample sizes or specialized expensive glassware.; ii) The relation between degradation of polysaccharides and changes in viscosity seldom occur in a simple linear fashion (Rapp *et al.*, 1984), and; iii) There is no direct connection between viscosity and the quantity of polysaccharide hydrolyzed. In proportion to their relative hydrolytic activity upon a given substrate exopolysaccharidase action tends to result in relatively little change in the viscosity of a solution compared with the same amount of hydrolytic activity from an endopolysaccharidase (Canevascini and Gattlen 1981; Firantas *et al.*, 1983). These limitations militate against β -mannanase assays based on changes in viscosity.

Gel filtration and/or TLC followed by total acid hydrolysis and HPLC analysis of the separated hydrolysis products was considered too expensive and time consuming a protocol to be considered for routine assays involving large numbers of samples. Reports that other researchers had only had limited success in using this protocol to separate and measure hetero-oligomers greater than 7 or 8 units also discouraged consideration of this method (McCleary and Matheson 1983; 1986).

The use of assays based on the detection of the released dye from a given substrate is limited by the availability of β -D-mannans-dye complexes and by reports indicating that dyes do not bind readily or completely to most β -D-mannans (Wood 1980). In addition, changes in the pH and ionic strength of the reaction-mixture have been reported to affect dye complexing (Wood 1980). Dye-conjugates are not natural substrates, and

therefore, may not mimic the target linkage accurately. Furthermore, very few researchers have used dye assays to quantify β -mannanase activities levels therefore, use of such an assay would severely limit the ability to compare β -mannanase levels with those reported in the literature. Numerous polysaccharidase assays are based upon detection of the reducing sugars released during the enzymatic hydrolysis of a polysaccharide. Although reducing sugar assays do not distinguish between different monomeric sugars and are less sensitive to oligomers than monomers, they do provide a relatively simple, inexpensive rapid method for measuring the extent of hydrolysis. For these reasons, this type of assay has become the technique of choice among researchers who frequently analyze large numbers of samples. The most commonly used techniques are the dinitrosalicylic acid (Miller 1959), and the Nelson-Somogyi (Somogyi 1952) assays. The DNS assay is a simpler protocol and more rapid reaction than Nelson-Somogyi. However, the Nelson-Somogyi reaction is more sensitive. Although both methods have been reported to be influenced by incubation conditions, the DNS assay is more readily affected. Variation in the response of the DNS assay with the type of lignocellulose material assayed is greater than the variability recorded in the Nelson-Somogyi assay under the same conditions. Furthermore, there is greater variability in the response of the DNS reaction to different monomer and dimer mixtures than found in the Nelson-Somogyi reaction (Breuil and Saddler 1985). Therefore, the Nelson-Somogyi reaction was chosen to measure β -mannanase activity levels. Where a more rapid estimate of relative activity was sufficient the DNS technique employed.

The substrate, its concentration, and the length of time the reaction-mixture is incubated are all factors that need to be considered in comparing reported activity levels

and in developing a standard assay method. It has been clearly established by several researchers that even under identical assay conditions the activity of a given β -mannanase is a function of the type of β -D-mannan used to assess the enzyme. For example, the specific activity of *T. harzianum* E58 β -mannanase 6.55 obtained when locust bean β -D-galactomannan and pine β -glucomannan were used as substrates was 73.4 and 44.2 Units/mg protein respectively (Table 8; Figure 15). The incubation time (Figure 9) and the concentration of a given β -D-mannan in the reaction mixture (Figure 15) have also been shown to affect the specific activity value observed for β -mannanase 6.55.

A survey of the current literature reveals that a variety of assay methods have been used to monitor the β -mannanase levels from different species and strains of organisms and that the activity has been expressed using various types of units (Table 3). Different strains of a given species vary in their ability to utilize β -mannans. For example, the strain of *Thielavia* assessed in the current study did not have detectable β -mannanase activity while Araujo and Ward (1990a) reported that *T. terrestris* ATCC 26917 and *T. terrestris* NRRL 8126 possessed β -mannanase activity levels of 2.8 and 12.5 Units/mL culture filtrate. In the same study one strain of *Talaromyces emersonii* exhibited a level of 43.6 Units/mL while another strain possessed a β -mannanase activity of only 0.6 Units/ml under identical assay conditions. Unfortunately Araujo and Ward (1990a) did not report the mg protein/mL of culture filtrate and, thus, it is not possible to determine if the differences in the enzyme activity levels reported between strains arose from variations in growth or in protein production. Even without a standard measurement method, comparison of β -mannanase level would be more meaningful if activity levels were reported using the same units, i.e. μ mol reducing sugar equivalent released per

minute per mg protein, and if the strain of the organism used, growth substrate, and conditions employed were routinely stated.

In this study, as with most studies reported in the literature, the method used to monitor β -mannanase activity represented an attempt to balance the need for a rapid convenient assay with the need for a precise accurate measurement of β -mannanase activity within the limitations of the economic and technical resources available. In spite of the absence of a standard β -mannanase assay, a great deal of information about the hydrolysis of β -D-mannans can be obtained by comparison of the conditions under which different β -mannanases are produced and active, the molecular properties of β -mannanases, and the products of enzyme hydrolysis of structurally different β -D-mannan substrates.

II. Production of Extracellular β -Mannanase by *T. harzianum* E58.

T. harzianum E58 did not produce extracellular β -mannanase when grown in medium supplemented with only mannose (Figure 6c; Figure 7), indicating that, in this organism, the β -mannanase system is inducible. Induction of β -mannanase has also been demonstrated in *Aspergillus giganteus* (Reese and Shibata 1965). Several workers have shown that the level of β -mannanase activity produced by a variety of organisms is a function of the carbohydrate present in the growth medium (Table 3), (Highley *et al.*, 1981; Johnson 1990; Rättö and Poutanen 1988; Williams and Orpin 1987). The nature of the polysaccharide in the growth media also affects the levels of endoxylanase and cellulase produced by *T. harzianum* E58 (Senior *et al.*, 1989b). In this study, the

pattern and the amount of β -mannanase activity produced by *T. harzianum* E58 grown on media containing Avicel, oat spelts xylan, and a variety of mannan-rich substrates, were compared in order to determine if the nature of the polysaccharide substrate also affects the β -mannanase system of *T. harzianum* E58. Since one of the goals of this research was to identify and isolate β -mannanase active proteins lacking cellulase activity, the level of endoglucanase activity was also monitored.

Although growth medium containing 1% (w/v) xylan did not result in β -mannanase activity detectable by the Nelson-Somogyi assay, zymogram analysis of culture filtrates revealed proteins of pI values 5.59 and 6.55 that exhibited β -galactomannanase activity (Table 5; Figure 7). This observation is probably a result of the greater sensitivity of the zymogram assay. The greater sensitivity of both the zymogram technique, and the Congo-red agar assay, to oligomer production would also explain why β -mannanase activity was usually detected (Figure 4), 12 - 24 hours before activity could be measured by the Nelson- Somogyi technique (Figure 5).

β -Galactomannanase activity was detected in the filtrate of all other cultures after 2 to 3 days growth (Figure 5). Growth on SWS and growth on konjac root powder β -D-glucomannan resulted in consistent but relatively lower levels of both β -mannanase and endoglucanase activity (IU/mL filtrate) than growth on either Avicel or locust bean gum β -D-galactomannan. The specific activity levels detected in the culture filtrates of the cells grown on spruce water solubles were lower than the values obtained with the other substrates (Table 5). Wood decomposition products present in the water-soluble fraction of steam treated aspen wood have been shown to repress cellulase production by *T. harzianum* E58 (Saddler and Mes-Hartree 1984). It is probable that decomposition

products present in the spruce water-solubles inhibit both cellulase and β -mannanase production.

Although the specific activity of the β -mannanases produced in medium containing konjac root powder β -D-glucomannan was greater than that found in spruce wood water soluble culture filtrates, the former resulted in the lowest levels of extracellular protein and enzyme activity per mL of culture filtrate. Why supplementing the growth medium with konjac root powder β -D-glucomannan should result in such low extracellular protein levels is unclear. Konjac root powder β -D-glucomannan supplementation may result in absorption of extracellular protein to the mycelium. The products of the hydrolysis of this polysaccharide may reduce the production of extracellular proteins and/or their activity. It is also possible that only limited forms of β -mannanase are formed or excreted in the presence of konjac root powder β -D-glucomannan. Whatever the cause of the low levels of extracellular activity in konjac root powder β -D-glucomannan culture filtrates, there is clear evidence that growth conditions have a profound influence on the phenotypic expression of β -mannanase in *T. harzianum* E58.

When culture filtrates of each of the polysaccharide media were separated by IEF and the protein bands assayed directly by an overlay zymogram (Figure 7), multiple forms of β -mannanase were detected. Multiple forms of β -mannanase have been reported to occur in several organisms (Akino *et al.*, 1989a; McCleary 1988e; Takahashi *et al.*, 1984) including *Polyporus versicolor* (Johnson and Ross 1990), *Thievalia terrestris* (Araujo and Ward 1990c) and *Bacillus pumilus* (Araujo and Ward 1990b). Although, the presence of multiple forms of β -mannanases and the quantity produced by other organisms has not been reported to correlate with the polysaccharide composition of the

growth substrate or with a decrease in medium pH during growth, a decrease in pH during growth and a corresponding production of acidic protease have been implicated in the inactivation of cellulases (Halliwell 1979; Kalra *et al.*, 1984). In the current study, protease activity could not be correlated with the appearance of multiple forms of β -mannanase. When the culture filtrate of locust bean gum β -D-galactomannan supplemented medium was concentrated 40-fold, faint clearing bands were detected in the acidic region by zymogram analysis. This observation suggests that, even in culture filtrates where the pH is near neutrality, very low constitutive levels of acidic β -mannanases are present. Whether the acidic pH of the medium is directly responsible for increased production of acidic β -mannanases remains to be determined.

While the cellulase activity of certain strains of *Trichoderma* spp. are reported to be repressed and/or inactivated in the presence of monomeric sugars (Eriksson 1979), both β -glucomannanase and β -galactomannanase activities were present when *T. harzianum* E58 was grown in 0.5 - 1% (w/v) locust bean gum β -D-galactomannan medium supplemented with 0.5% (w/v) mannose (Table 5; Figure 6b; Figure 7). The same level and profile of activities were obtained in the β -D-galactomannan containing medium in either the absence or presence of supplementary mannose. This indicated that although mannose did not induce β -mannanase production, there was no repression of production at levels that could be expected during the hydrolysis of substrates containing 0.5 - 1.0% (w/v) mannan. Moreover, the profile and number of mannanases detected did not differ when 1% (w/v) mannose was present in the zymogram substrate gel. This further demonstrated that this concentration of mannose did not significantly inhibit β -mannanase activity.

By contrast, the presence of mannose in the growth medium containing locust bean gum β -D-galactomannan did alter the number and profile of β -mannanases detected by the zymogram technique using β -D-glucomannan and β -D-galactomannan substrates (Figure 7). In fact the number of bands showing β -mannanase activity varied among filtrates of the polysaccharide media as well (Figure 7). Enzymes with low isoelectric points (pH less than 4.5) were detected in the spruce water-solubles and Avicel grown filtrates but not in locust bean gum or konjac filtrates (Figure 7). When 0.5% locust bean was supplemented with 0.5% mannose, these acidic mannanases could also be detected, although at mannose levels lower than 0.1% the bands were not detectable. In all cases the mannanases with acid pI values were detected in filtrates whose pH had dropped below 4.5.

As stated previously, because of potential commercial applications, β -mannanase activity which does not occur in association with cellulase activity is of particular interest. Endoglucanase values obtained after growth of *T. harzianum* E58 on mannan-rich substrates were less than half of the equivalent values obtained after growth on medium containing Avicel. The reduced levels of endoglucanase activities (Figure 5) may be a response to the relative amounts of the cellulose and mannan components originally present in the growth medium. When β -D-mannan-rich substrates were acid hydrolysed and the component sugars analyzed by HPLC, the ratio of mannose to glucose in each of the substrates appeared to be related to the ratio of β -galactomannanase and β -glucomannanase to endoglucanase activities detected (Table 6).

In earlier work on xylanase production by *T. harzianum* E58, the regulation of the cellulase and xylanase enzymes appeared to be under separate control (Senior *et al.*,

1989b). This is also true of several other fungi (Biely 1985; Hrmovà *et al.*, 1986). However, the similar time frame of β -mannanase and endoglucanase production observed in Figure 5 made it difficult to determine if the regulation of these two enzymes was under separate control. A previous report (Lyr 1963), indicated that higher extracellular β -mannanase levels were obtained when various fungi were grown on cellulose as compared with mannan-rich substrates. *T. harzianum* E58 appears to follow this pattern. However, on the basis of specific activity, filtrates from the cultures grown on locust bean gum exhibited a 3.6 and 3.8 fold increase in respective β -galactomannanase and β -glucomannanase specific activities over those obtained after growth on Avicel (Table 5). Based upon the higher specific activity and the lower level of endoglucanase found in the culture filtrates obtained after growth on locust bean gum β -D-galactomannan medium, culture filtrate of *T. harzianum* E58 grown on this substrate was used in the subsequent work on the isolation and characterization of cellulase-free β -mannanase activity.

III. Isolation and Properties of Extracellular β -Mannanase 6.55 from *T. harzianum* E58 Culture Filtrate.

A. Isolation of β -mannanase 6.55.

Unlike other fungal extracellular polysaccharidases (DeGussem *et al.*, 1978, Johnson *et al.*, 1988, Johnson *et al.*, 1990; Tan *et al.*, 1987a; Urbanek *et al.*, 1978, Uziie *et al.*, 1985, Wolter *et al.*, 1980), β -mannanase 6.55 from *T. harzianum* E58 was purified to homogeneity with comparative ease using a three step process involving ultrafiltration, ion exchange chromatography, and gel filtration.

The association of β -mannanase activity with the Pellicon retentate after ultrafiltration of the culture filtrate through a series of 10 kD membranes (Table 7) is to be expected given the molecular weight of β -mannanase 6.55 (mwt \approx 43 kD, *vide infra*). Similarly, the presence of endoxylanase in the ultra-filtrate is not surprising since a portion of *T. harzianum* E58 xylanase activity has been reported to be associated with protein capable of passing through the Pellicon system (Tan *et al.*, 1985b).

Anion exchange chromatography proved to be a powerful and efficient procedure for removal of extraneous enzyme activities, particularly endoxylanase from the *T. harzianum* E58 β -mannanase. *T. harzianum* E58 xylanases possess pI values of 8.5, 9.4, and 9.5 (Tan *et al.*, 1985b; Wong *et al.*, 1986). The appearance of xylanases in the void volume of the anionic chromatography column buffered at pH 8.6 indicated, as expected on the basis of their pI values, that xylanase activity did not bind to the DEAE-Sephrose (Figure 10). In contrast, β -mannanase 6.55 which would have been expected to bind very tightly to an anion exchange column equilibrated at pH 8.6, was eluted with a very low salt concentration indicating that its anionic interaction was very weak

(Figure 10). In addition, although proteins of pI 6.55 would normally be expected to bind to anion exchange chromatography columns equilibrated at pH 7.45 or 8.1, β -mannanase activity was weakly and incompletely immobilized on these columns. The β -mannanase system of *P. versicolor* was also found to require anion exchange columns equilibrated at higher than expected pH values in order to achieve binding (Johnson *et al.*, 1990). Johnson and his coworkers (1990) found that a DEAE-Bio-GelA anion column of pH 8.5 was required to bind β -mannanase activity associated with proteins of pI 3.75 - 4.6. Although these proteins possess low pI values, the surface charge of the protein and the distribution of charge may be such that proteins do not form many electrostatic bonds with the DEAE solid matrix and, therefore, are easily exchanged by small variations in the salt concentration of the aqueous phase of the column.

α -Galactosidase activity was detected in the two protein peaks that eluted from the anionic column after the β -mannanase had been eluted (Figure 10). These proteins were unable to release detectable levels of reducing sugar from locust bean gum β -D-galactomannan. McCleary (1983b) found α -galactosidases isolated from germinating seeds were capable of detectable hydrolysis of β -D-galactomannans in the absence of β -mannanases. However, Kaneko and his colleagues (1990), reported that the α -galactosidase isolated from the fungus *Mortierella vinacea* catalyzed the hydrolysis of terminal α -galactoside linkages from the non-reducing end of galactomannan oligomers but not branch point linkages within the oligomer. Extracellular *T. harzianum* E58 α -galactosidase activity detected in the anion exchange fractions may have a substrate specificity similar to *M. vinacea* α -galactosidase. It is possible that access to their substrate binding sites is limited by the tertiary structure of unhydrolyzed locust bean gum

β -D-galactomannan and, thus, the enzymes appear unable to release the α -(1,6) galactose from locust bean gum β -galactomannan. However, these α -galactosidase enzymes may, in concert with the β -mannanases of the fungus, play a key role in the complete hydrolysis of β -D-galactomannans. In his studies of the enzymatic interactions occurring within germinating guar seeds, McCleary (1983b) found that β -endomannanases and α -galactosidase activity proteins are produced at the same time, and along with β -exomannanases, are involved in the complete hydrolysis of guar gum β -D-galactomannan.

Zymogram analysis indicated that most of the extracellular endoglucanases from *T. harzianum* E58 grown in medium containing 1% (w/v) locust bean gum β -D-galactomannan exhibited acidic pI values (Figure 8). The absence of detectable endoglucanase activity in the anionic chromatography fractions reflected the low pI values of these proteins most of which were probably tightly bound to the resin. Only trace levels of endoglucanase activity were detected in the pooled concentrated β -mannanase fractions (Table 8) obtained from the anion exchange chromatography step.

To remove trace contaminating endoglucanase activity from the β -mannanase obtained from anion exchange, this preparation was subjected to gel filtration. Superimposable, symmetrical peaks of A_{280} , β -D-galactomannanase, and β -D-glucomannanase activities were eluted (Figure 11). After pooling and concentration of these peak fractions, the resultant preparation did not contain detectable endoglucanase activity. Subsequent IEF and SDS-PAGE analyses of the preparation revealed the presence of a single protein of molecular weight 42.9 kD and pI of 6.55. It was on this basis that *T. harzianum* E58 β -mannanase 6.55 was judged to be homogeneous.

Overall, the process generated a 2.82-fold purification of the enzyme with approximately 15% recovery of the original total culture filtrate activity (units/mL), using β -D-galactomannan and β -D-glucomannan as substrates. The consistent loss of input activity during purification has been noted in the preparation of other fungal β -mannanases, (Araujo and Ward 1990d, Ishihara and Shimizu 1980, Johnson *et al.*, 1990, Park *et al.*, 1987). The specific activity values of the purified protein are within the range of those reported in the literature where appropriate comparison can be made. Once homogenous, β -mannanase 6.55 proved to be highly stable.

B. *Molecular properties of β -mannanase 6.55.*

The native molecular weight of the major protein of the β -mannanase preparation obtained by anion exchange chromatography was estimated by gel filtration chromatography (Figure 11) to be 39.8 kD. Molecular weight determination of the β -mannanase by SDS-PAGE generated a value of 42.9 kD which was in very close agreement with the molecular weight estimated by gel filtration. Normally the native molecular weight would be expected to be slightly higher than the denatured protein weight due to the presence of glycosidic groups and other substituents associated with the native protein. Variation in the apparent molecular weight of a *Trichoderma* cellulase have also been found when these two methods were used (Håkansson *et al.*, 1978; Ülker and Sprey 1989). Ülker and Sprey (1989) proposed that these proteins have tertiary non-globular structures which lead to altered sieving properties during gel filtration. They therefore, recommend that molecular weight determinations be based on the values obtained by SDS-PAGE analysis.

The apparent molecular weight of the extracellular *T. harzianum* E58 protein, β -mannanase 6.55, as determined by SDS gel electrophoresis is within the 30-89 kD range reported for fungal β -mannanases (Table 9). Since similar values were obtained by native gel filtration (Figure 11) and SDS gel electrophoresis (Figure 12) it was assumed that β -mannanase 6.55 is a monomeric enzyme. Fungal β -mannanases reported to date have been monomeric, while dimeric (Talbot and Sygusch 1990) and trimeric (Gherardini and Salyers 1987a; 1987b) as well as monomeric β -mannanases have been isolated from bacterial cultures.

The relatively high pI value of this enzyme makes it unique among the fungal β -mannanase characterized to date. With the exception of two β -mannanases with pI values of 7.0 and 7.7 isolated from snail gut juice (McCleary 1979b), a cell wall associated β -endomannanase with a pI of 6.9 from *Bacteriodes ovatus* (Gherardini and Salyers 1987), an extracellular β -mannanase recently isolated from *Pseudomonas* spp. PT-5 (Yamaura *et al.*, 1990), and an β -exomannanase with pI 9.4 isolated from guar seeds (McCleary 1988c), all other β -mannanases that have been described possess pI values of less than 6.0. Although a few bacterial β -mannanases possessing pI values greater than 5.5 have been reported, the fungal β -mannanases described have been proteins with isoelectric points of 4.6 or lower (Table 9). Without detailed knowledge of the tertiary structure and charge distribution of the mannanase or specific information about its active centre, it is difficult to elucidate the significance of the pI value of the protein with respect to its enzymatic activity, structure, or stability. However, it is interesting to note that β -xyianases having pI values of 9.4 and 9.5, which are higher

pI values than most other β -xylanases have also been isolated from *T. harzianum* E58 (Tan *et al.*, 1985a;1985b).

C. *Substrate specificity of β -mannanase 6.55.*

The inability of the β -mannanase 6.55 to hydrolyze *p*-nitrophenol mannopyranoside, mannobiose, mannotriose and mannotetrose, along with the TLC profile of the hydrolysis products of β -D-mannans (Figure 13) are consistent with the action of an endo-mannanolytic β -mannanase. Both Araki (1983) and McCleary (1979b) have proposed that β -mannanases be classified on the basis of their ability to hydrolyze homomeric β -D-manno-oligomers. Araki (1983) recognized 3 classes of β -mannanases: I) those that are capable of hydrolyzing manno-oligomers of DP > 2 such as the β -mannanases isolated from *A. niger* (Yamazaki *et al.*, 1976) and *Penicillium purpurogenum* (Park *et al.*, 1987); II) those that can hydrolyze manno-oligomers of DP > 3, for example, the β -mannanases of the alkalophile *Bacillus* sp. AM001 (Akino *et al.*, 1988), *B. subtilis* (Emi *et al.*, 1972), and *Pseudomonas* sp. PT-5 (Yamaura *et al.*, 1990), and III) those that are only effective on manno-oligomers of DP > 4 such as the β -mannanase of *Rhizopus niveus* (Hashimoto and Fukumoto 1969). β -Mannanase 6.55 appears to be a class III β -endomannanase.

Since most β -D-mannans are heteropolymers, the ability to hydrolyze monomeric manno-oligomers should not be the sole criteria for classifying β -mannanases. Their ability to catalyze the degradation of β -D-glucomannans, β -D-galactomannans, and β -D-galactoglucomannans should also be considered in any classification scheme. As discussed in the Introduction, the degree and distribution of α -linked galactoside

substituents affects β -mannanase activity. Most of the β -mannanases isolated and characterized to date have been reported to vary in their ability to hydrolyze β -D-galactomannans with varied content of α -linked galactoside substituent. Research by McCleary and his coworkers (McCleary 1979a; 1979b; 1988a; McCleary and Matheson 1983; 1986) has shown that β -mannanases also differ in their ability to hydrolyze β -D-galactomannan which vary in the distribution of α -galactopyranosyl substituents along the β -D-mannan backbone. The lower enzyme efficiency (V_{max}/K_m) and affinity of β -mannanase 6.55 towards guar gum compared with locust bean gum β -D-galactomannan (Table 10) may reflect the inability of the enzyme to bind to and hydrolyze β -1,4 mannose - mannose linkages at or near α -galactoside branch points.

Differences in the substituent groups and glucose content of β -D-glucomannans have also been shown to affect β -mannanase activity. McCleary (1991) reported salep β -D-glucomannan, which has a higher proportion of mannose to glucose (80:20) than konjac root powder β -D-glucomannan (60:40) or wood β -D-mannans (radiata pine 71:27 to 75:24), was more extensively hydrolyzed than konjac root powder. McCleary and Matheson (1983), also found that deacetylated salep was more extensively hydrolyzed by *A. niger* β -mannanase than the native salep.

On the basis of kinetic parameters, deacetylated konjac root powder β -D-glucomannan was a much poorer substrate than native konjac root powder β -D-glucomannan. Deacetylation of konjac root powder β -D-glucomannan did not result in a change in the substrate binding affinity of β -mannanase 6.55 (K_m), but the catalytic rate (V_{max}), decreased by more than 50%, lowering the overall efficiency value by 40% (Figure 16; Table 10). In their study of the β -mannanases of *Polyporus versicolor*,

Johnson and Ross (1990) also reported that deacetylated konjac root powder β -D-glucomannan was a poorer substrate than the native acetylated form. Unlike β -mannanase 6.55 however, both the catalytic rate and the affinity of the *P. versicolor* enzymes for deacetylated substrate were significantly lower than that obtained for the acetylated substrate (Johnson and Ross 1990). The superiority of natural konjac root powder β -D-glucomannan as a substrate was thought by Johnson and Ross (1990) to reflect the greater solubility of the natural as opposed to deacetylated form of the substrate. This hypothesis is supported by studies carried out by Maekajji (1974) that suggest that acetyl groups within konjac alter its tertiary structure and removing them decreases polymer solubility.

The dissimilarity of the response of *A. niger* β -mannanase to deacetylated salep compared with the response of *P. versicolor* β -mannanases and β -mannanase 6.55 to deacetylated konjac root powder β -D-glucomannan may reflect differences in the tertiary structure of the deacetylated forms of the two substrates. As McCleary (1991) explained, salep β -D-glucomannan powder remains in solution after deacetylation while removal of acetyl groups from konjac root powder β -D-glucomannan leads to its precipitation due to self association of the konjac root powder polysaccharide.

Differences in the affinity of β -mannanase 6.55 for the two β -D-glucomannans, konjac root powder and pine β -D-mannans (Table 10) may be also reflect differences in the structures of these β -D-glucomannans. Since the pine β -D-glucomannan was extracted by strong alkylating reagents (McDonald 1987), it is possible that deacetylation of pine β -D-glucomannan occurred and lower enzyme affinity towards pine β -D-glucomannan as inferred from the measured K_m may have arisen from resulting changes

in the β -D-mannan structure. To determine if substrate acetylation plays a role in the enzyme efficiency of β -mannanase 6.55 towards pine β -D-glucomannan one would need to prepare a series of acetylated pine β -D-glucomannans and compare the kinetic parameters for each substrate.

If deacetylation of wood β -D-mannans did, in fact, decrease the extent of enzymatic hydrolysis by β -mannanase 6.55, the ability of purified β -mannanases to work in concert with other hemicellulases could be affected. Unlike deacetylation of β -D-glucomannan, deacetylation of xylans has been reported to increase the susceptibility of xylan to xylanases (Grohmann *et al.*, 1989; Wood and McCrae 1986). Esterases and xylanases are reported to act synergistically on acetyl xylans (Biely *et al.*, 1986). Deacetylation or the addition of esterases may aid in the hydrolysis of the xylan components of the lignocellulose matrix while at the same time making the β -D-glucomannan component of the matrix more recalcitrant to enzyme treatment.

D. *Affectors of enzyme activity.*

Once a protein lacking xylanase and cellulase activity but capable of hydrolyzing β -D-mannan had been identified and isolated, the next objective was to characterize the enzyme and assess its potential vis-à-vis the type of environment in which it could be utilized. For example the temperature optima, thermostability, and pH optima of the enzyme, as well as the effects of solvents, ionic environment, detergents, and proteases upon enzyme activity, could all have an impact on potential applications.

The temperature optimum for β -mannanase 6.55 activity varied, between approximately 60 - 65°C, depending upon the nature of the assay substrate (Figure 17).

The higher optimum temperature observed when konjac root powder β -D-glucomannan, locust bean gum β -D-galactomannan, or guar gum β -D-galactomannan were used as assay substrates may reflect the ability of these substrates to protect the protein, to some extent, against thermal denaturation. Studies wherein the enzyme was pre-incubated in the absence of any substrate indicated that thermostability, measured as residual activity, was independent of the type of β -D-mannan substrate. This observation is consistent with the hypothesis that variations in observed temperature optima are a result of interactions between a given substrate and the enzyme.

Most extracellular fungal and bacterial β -mannanases have a temperature optimum between 60 - 70°C (Table 9). The thermostability of β -mannanases is much more variable. The thermostability of β -mannanase 6.55 (Figure 18) was comparable to that of the β -mannanases of *P. versicolor* (Johnson *et al.*, 1990), *Bacillus subtilis* (Emi *et al.*, 1972), and *Aspergillus tamaris* (Civas *et al.*, 1984). As would be expected, thermophiles such as *Thiobacillus terrestris* (Aruajo and Ward 1990c) produce β -mannanases that are more stable at higher temperatures (Table 9).

Some β -mannanases are only active over a comparatively narrow pH range. For example, the β -mannanase from *B. stearothermophilis* is stable only over a pH range of 5.5 - 7.5 (Talbot and Sygusch 1990). In contrast β -mannanase 6.55 maintains activity over a broad acidic pH range and still possessed approximately 15% of its activity at pH 9.0 (Figure 19). The reported pH optimum of fungal β -mannanases ranges from 3.6 to 5.6 (Table 9), while most of the bacterial β -mannanases described have pH optimum ranging from 5.5 - 7.5. Notable exceptions are the three bacterial β -mannanases of the

alkalophilic *Bacillus* sp. which possess pH optimum of 9.0, 9.0 and 8.5 (Akino *et al.*, 1988).

Like all β -mannanase of fungal origin assessed so far (Civas *et al.*, 1984; Johnson *et al.*, 1990; Park *et al.*, 1987), β -mannanase 6.55 activity is unaffected by EDTA but is inhibited by low levels of Hg^{2+} ions (Figure 20). In contrast, β -mannanase of *Pseudomonas* sp. PT-5 (Yamaura *et al.*, 1990) and the β -mannanase of *Streptomyces* sp. IV (Takahashi *et al.*, 1984) are both inhibited by EDTA and therefore are the only known β -mannanases suspected of being metalloenzymes.

In order to gain additional information on the stability of *T. harzianum* E58 β -mannanase 6.55 and to gain further insight into the nature of this protein, the effects of detergents, methanol, ethanol, and selected proteases on the ability to hydrolyze locust bean gum β -D-galactomannan were studied. The impact of ethanol, methanol and proteases on β -mannanase activity has only been reported for the β -mannanases of one other organism, *P. versicolor* (Johnson and Ross 1990). As well, there are few data regarding the effect of detergents on β -mannanases activity. Detergents are classified according to the charge on the hydrophilic portion of the detergent molecule. SDS, an anionic detergent frequently used for complete protein denaturation had little effect on the activity of β -mannanase 6.55 at any tested concentration (Figure 21). In their study of the β -mannanase system from *P. versicolor*, Johnson and Ross (1990) found that 0.5 % (w/v) SDS inhibited two of the four distinct β -mannanase activities while the activity of the other two more hydrophobic β -mannanases was enhanced by the addition of 0.5% (w/v) SDS. The effect of various detergents on the activity of β -mannanase 6.55 did not correlate with the type of detergent being tested (Figure 21). Similarly, after assessing

various types of detergents, Johnson and Ross (1990) found that the effect of detergents on activity of the *P. versicolor* β -mannanases could not be correlated with the type of detergent being tested. The stimulatory effect of a given detergent upon both the β -mannanases of *P. versicolor* and on β -mannanase 6.55, decreased at higher concentrations (≥ 0.2 to 0.5 % v/v), while inhibitory effects became stronger as the concentration of the detergent increased. Without specific analyses of these proteins one cannot explicitly aver that their relative resistance to significant concentrations of various detergents arises from unusual structural features, but it would seem probable that their active site is not available to the deleterious effects of detergents (or for that matter, to solvents or proteases which are discussed below) seen with most proteins. In addition, detergents can affect the solubility and tertiary structure of the substrate and therefore indirectly affect the availability of the substrate to the enzyme. Thus, the effect of detergent on enzyme activity may not be solely a result of the interaction between detergent and protein but might also involve solubility of the β -D-mannan substrate and its structure in solution. Such changes in substrate solubility and structure may alter both the degree of hydrolysis and the level of activity detected.

Both ethanol and methanol at concentrations of up to 20 % (w/v) appeared to enhance the activity of β -mannanase 6.55 (Figure 22), which was analogous to the previous observations on the activity of *P. versicolor* β -mannanases reported by Johnson and Ross (1990). In fact, the activity of the two more hydrophobic β -mannanases of *P. versicolor* was enhanced in the presence of 20 % (w/v) ethanol and remained active towards konjac root powder β -D-glucomannan at concentrations up to 40 % (w/v) ethanol (Johnson and Ross 1990). The ability to maintain activity in 20 - 60% (w/v) ethanol and

other organic solvents has been reported for several enzymes and many theories have been presented to explain the phenomenon (Deetz and Rozzell 1988; Klibanov 1986; Neidleman 1990; Scopes 1985). Whether the apparent increase in β -mannanase 6.55 activity in the presence of 20% (w/v) ethanol or methanol is the result of alterations in protein or substrate configuration, changes in the substrate affinity at the active site, or reaction partitioning, could not be determined from the available data.

Overall, the studies of effects of temperature, pH, metal ions, detergents, ethanol, and methanol on β -mannanase 6.55 and similar studies of *P. versicolor* β -mannanases (Johnson *et al.*, 1990; Johnson and Ross 1990) provide strong evidence that the activity of fungal β -mannanases may be part of a very stable tertiary protein structure. Likewise, the experimental data on the impact of protease pretreatment of β -mannanase implies that activity originates from a stable structure. β -Mannanase 6.55 retained at least 78% of its original activity towards both konjac root powder β -D-glucomannan and locust bean gum β -D-galactomannan after pretreatment with either pepsin, α -chymotrypsin, trypsin, or *Staphylococcus aureus* V8 protease (Table 11). This indicated that few or no proteolytic sites within the catalytically active micro-environment of the enzyme were exposed or available. However, protease K, a protease of fungal origin was able to obtain access to and cleave sites within β -mannanase 6.55 critical to enzyme activity thus lowering total activity by 66% (Table 11). In comparison, the four β -mannanases of *P. versicolor* have been reported to retain at least 65% of their activity after treatment with pepsin, trypsin, or α -chymotrypsin with the two more hydrophobic enzymes retaining at least 74% of their original activity. In addition the activity of the two hydrophobic enzymes, as

measured by the release of reducing sugars from konjac root powder β -D-glucomannan, was unaffected by pepsin treatment (Johnson *et al.*, 1990).

Proteolytic cleavage of an enzyme does not necessarily result in inactivation since catalytic domains can be highly organized and are often more resistant than the protease susceptible peptide loops that link the domains (Shami *et al.*, 1989). This may be the reason for the observed decrease in total protein and the corresponding increase in the relative specific activity of β -mannanase 6.55 after pepsin, α -chymotrypsin and trypsin treatment (Table 11). Even the observed decrease in the relative specific activity after pretreatment with protease K is less than half of the decrease in relative total activity (Table 11). Such data suggest that much of the protein hydrolyzed by this protease K was not critical for maintaining β -mannanase 6.55 activity towards locust bean gum β -D-galactomannan or konjac root powder β -D-glucomannan.

Similarly protease treatment of cellulases from *Trichoderma* sp. and other fungi has been shown to result in increased specific activity towards soluble substrates such as CMC (Chen and Grethlein 1988; Eriksson and Pettersson 1982; Hagspiel *et al.*, 1989; Tilbeurgh *et al.*, 1986). However, activity towards insoluble substrates such as wood or Avicel decreased after protease treatment (Chen and Grethlein 1988; Tilbeurgh *et al.*, 1986). This phenomenon has been attributed to the existence of separate binding and catalytic domains within the enzymes. Separation of the binding domain from the catalytic domain by proteases is believed to decrease the frequency of successful enzyme substrate interactions for insoluble substrates. It is possible that β -mannanases also possess catalytic domains and binding domains and that cleavage of the enzyme by protease treatment

results in the separation of these domains, which would lower the enzyme efficiency towards insoluble substrates such as lignocellulosics.

IV. The Interaction of *T. harzianum* E58 β -Mannanase 6.55 with Non-target Polysaccharides

Since β -D-mannans occur within a matrix that includes other plant cell wall materials, it is important to determine if β -mannanase 6.55 can function in the presence of cellulose, xylan, and lignin. Experimental data investigating the impact of celluloses and xylans on the activity β -mannanases towards their target β -mannan substrates has not been previously reported. Although celluloses and xylans were not degraded by β -mannanase 6.55, the presence of these non-target polysaccharides, especially celluloses, often influenced the ability of the enzyme to hydrolyze its target substrate (Figure 23, Table 12).

The observed decrease in the specific activity of β -mannanase 6.55 towards pine β -glucomannan might arise from several sources including: the presence of inhibitory material in the pine xylan fraction, non-specific enzyme adsorption by the xylan, and/or mannan-xylan complexing could limit enzyme access to the target substrate. In contrast, hardwood xylans did not appear to affect the specific activity of the enzyme nor did β -mannanase activity adsorb to the insoluble fractions of these hardwood xylans. Structural differences between softwood xylans and hardwood xylans may account for this disparity. Although the presence of 0.25% larchwood xylan did not significantly increase the overall efficiency of β -mannanase 6.55 towards locust bean gum β -D-galactomannan,

the apparent increase in both the catalytic rate (V_{max}), and the K_m value (Table 12), suggests that even hardwood xylans may alter the micro-environment in which enzyme-substrate interaction occurs (Table 12).

The presence of Avicel (1 % w/v) had an unequal effect on the apparent catalytic rate and K_m and lowered the efficiency of the enzyme by 52.7% (Table 12). The decrease in the affinity of β -mannanase 6.55 for locust bean gum β -D-galactomannan, as reflected in the three fold increase in the apparent K_m due to the presence of 1% (w/v) Avicel, suggests that the association of Avicel with either the β -D-mannan or with the enzyme itself is a factor contributing to the lower enzyme efficiency. However, caution should be exercised when interpreting this preliminary data. According to Lehninger (1975), Michaelis-Menten kinetics only apply to a system if the inhibitor combines rapidly and reversibly with the enzyme. It is not known if Avicel meets these prerequisites. Further studies would be required to determine the nature of the affect of Avicel upon β -mannanase 6.55 efficiency.

Independent of the mechanism(s) by which different forms of cellulose affect enzyme activity, there was clear evidence for a β -mannanase-cellulose association. When β -mannanase 6.55 was preincubated with various concentrations of either Avicel or Solka floc, enzyme activity was associated with the insoluble cellulose (Table 13). β -Mannanase activity was still present after the cellulose was washed twice with buffer suggesting that the protein was strongly adsorbed to the cellulose under these conditions. The total enzyme activity initially present in the reaction mixture could be accounted for by summing the amounts of activity occurring in the buffer wash and associated with

Avicel. Hence, adsorption of β -mannanase 6.55 to Avicel did not result in a reduction or loss of measurable β -mannanase activity (Table 13).

Although adsorption of β -mannanase activity to cellulose has not been previously reported, adsorption of *T. harzianum* E58 xylanase to Avicel has been reported (Senior *et al.*, 1990; 1991). Moreover, the xylanase component of commercial enzyme preparations has also been reported to adsorb to a variety of celluloses (Tatsumoto *et al.*, 1988) and the adsorption of cellulases to cellulose which has been known for at least thirty years (Halliwell 1979), is an extensively studied phenomenon. In the past 15 years, various factors such as pH, ionic strength, substrate structure and surface area, protein structure changes and hydration, temperature, the enzyme:substrate ratio, as well as the presence of enzyme-enzyme complexes or potential complexing, have been identified as factors affecting protein adsorption to polysaccharides (Gilbert and Tsao 1983, Kyriacou *et al.*, 1988; 1989, Tomme *et al.*, 1988). The mechanism of adsorption is believed to be primarily a hydrogen bonding of the protein onto cellulose surfaces (Kyriacou *et al.*, 1988; 1989), and each component of the cellulase complex was postulated to have distinctly different adsorption sites on cellulose as well as different rates of adsorption to the cellulose (Ryu *et al.*, 1984). In fact the variation in the substrate affinity and the adsorption of cellulases to insoluble substrates after exposure to proteases aided in the discovery of separate binding and catalytic domains within cellulases. By consolidating the information obtained from studies of cellulases complexes and domains, a general model for enzymatic hydrolysis of insoluble polymeric substrates such as lignocellulosics, based on the existence of different domains with variable affinity for the substrate has recently been developed (Ståhlberg *et al.*, 1991). Such a model,

describing domains within an enzyme as possessing different substrate affinities and functions, may apply to the enzymes involved in the degradation of β -D-mannans as well. However, the detailed characterization studies of β -mannanases, needed to determine if this model could also be applied to β -mannanases, have yet to be carried out for β -mannanases.

If β -mannanases are to be of practical value in the selective removal of β -mannan from lignocellulosic material during biobleaching they must function in an environment containing little mannan but rich in cellulose. Therefore the nature of the observed decrease in enzyme efficiency in the presence of Avicel, the basis of the adsorption of β -mannanases to non-target polysaccharides, as well as the effect of substrate and enzyme concentration upon the interaction of β -mannanases with non-target polysaccharides should be explored further.

Equally important is an understanding of the relationship between lignins and β -mannanases. The binding of *Trichoderma* spp. cellulases to hardwood lignins and softwood lignin-carbohydrate complexes is reported to reduce activity (Chernoglazov *et al.*, 1988). Cellulase adsorption to lignin has been shown to be influenced by the nature of the insoluble portion of the lignin (Sutcliffe and Saddler 1986). Loss of *T. harzianum* E58 xylanase activity is thought to be due partially to nonspecific adsorption to lignin and is reported to be strongly inhibited by water soluble lignins (Senior *et al.*, 1991). In contrast, the presence of 1% (w/v) spruce wood water solubles did not appear to inhibit the activity of β -mannanase 6.55. The release of reducing sugars from spruce sawdust and the spruce LCC during incubation with β -mannanase 6.55 demonstrated the ability of the enzyme to be active in the presence of lignin. However, lignin may present a

recalcitrant physical barrier to the enzymatic hydrolysis of β -D-mannans. Such a barrier could account for the relatively low levels of reducing sugars released from LCC by β -mannanase 6.55 (Table 14) and other β -mannanases (Ross *et al.*, 1991), even when β -mannanases are used with a mixture of other hemicellulases. Even in wood pulp studies using crude hemicellulase mixtures where treatment has been shown to enhance chemical bleaching, complete removal of residual carbohydrate was not achieved (Viikari *et al.*, 1991). In studies on the interaction of hemicellulases and their ability to hydrolyze hardwood lignin carbohydrate complexes Overend and Johnson (1991) did not observe the release of small oligomers or monomers from the complex after treatment with various hemicellulase mixtures. They suggested that the lignin protected the carbohydrate component of the complex from extensive enzymatic hydrolysis in part, as a result of the high potential of lignins for ion binding and the occurrence of conformational changes in the lignin-carbohydrate complex during initial hydrolysis that increased its recalcitrance.

V. The Interaction of *T. harzianum* E58 β -Mannanase 6.55 with Other Hemicellulases

Only limited preliminary studies of the interaction of β -mannanases during the hydrolysis of β -D-mannans and lignocelluloses have been carried out. When combined, some *P. versicolor* β -mannanases displayed a synergistic relationship while other combinations resulted in negative interactions with respect to degradation of konjac root powder β -D-glucomannan (Johnson and Ross 1990). By contrast, data from preliminary studies indicated that the activity of *Thielavia terrestris* β -mannanases on coffee bean β -mannan is additive (Araujo and Ward 1990b). Whether the multiple forms of β -mannanases from *T. harzianum* E58 (Figure 7), interact synergistically or not was not

studied. If these enzymes did interact synergistically one would have expected a decrease in the specific β -mannanase activity of the preparation as the multiple forms of the enzyme were separated and a single enzyme isolated. As the data summarized in Table 7 and Table 8 show, this appeared not to be the case. However multiple forms may have a role in the hydrolysis of other β -D-mannans and/or during hydrolysis under different abiotic conditions.

To determine if other hemicellulases acting in concert with β -mannanase 6.55 could increase the amount of reducing sugars liberated from a lignocellulose, various combinations of hemicellulases were assessed using spruce LCC. The complexity of interaction among these enzymes and between enzyme activity and substrate are reflected in the synergistic release of reducing sugars found only when all four enzyme preparations (β -mannanase, β -xylanase, α -galactosidase, and acetyl xylan esterase) were present (Table 14). The low levels of reducing sugars released from the spruce LCC by xylanase treatment alone probably reflects the inhibitory effect of lignin on *T. harzianum* E58 xylanases (Senior *et al.*, 1991). Variable patterns of inhibition and synergy according to the types of enzyme activity present have been documented in other studies examining the enzymatic treatment of hardwood LCCs (Overend and Johnson 1991). Researchers, studying the ability of hemicellulase mixtures to release reducing sugars from hardwood LCCs, have found that acetyl xylan esterase was essential for the release of detectable levels of reducing sugars from some LCCs (Overend and Johnson 1991). In other studies of hardwood LCC degradation researchers found that the effect of combining acetyl xylan esterase with three of the four β -mannanases tested was relatively small. In fact, combining the fourth β -mannanase with acetyl xylan esterase resulted in a 40 %

inhibition of expected activity (Ross *et al.*, 1991). From these studies it was (Ross *et al.*, 1991) concluded that the observed increases in the release of reducing sugars could be explained by the effect of deacetylation on xylanase activity.

A rather interesting observation arising from the combination enzyme studies with black spruce LCC was that only when α -galactosidase was present with the other three hemicellulases did one observe a synergistic hydrolytic response. In the absence of any of the other three hemicellulases, α -galactosidase did not appear to augment the release of reducing sugars equivalents from the spruce LCC. While this may imply that certain α -galactose substituents in the substrate matrix must be hydrolyzed to facilitate more complete enzyme action, it is equally possible that non-catalytic binding to the matrix might evoke conformational changes that ultimately result in enhanced action by the other hydrolytic enzymes. Whatever the case, it is clear that hydrolysis of such complex substrates by enzyme mixtures is not straight forward and predictive models will require much higher degrees of definition with respect to the conformation of both the enzymes and substrates involved.

In all studies, very high dosages of enzymes were added to overcome any inactivation resulting from non-specific adsorption and any possible inhibition of the enzymes. These studies have provided some insight into the mechanisms of lignocellulose hydrolysis. However, the use of such high levels of enzymes can lead to excess ineffective loading of the individual enzymes and is unlikely to be cost effective on an industrial scale. Thus, before enzymatic hydrolysis can become an effective tool in the selective modification of LLCs a more complete understanding of the physicochemical relationship between enzymes and LCCs must be obtained. In order to achieve this

understanding, more highly defined hemicellulose and lignin substrates will be needed. With this understanding the full potential of enzymes in waste treatment and biobleaching can be realized.

Concluding Remarks

There are now several examples, such as starch hydrolysis and biological bleaching, where large scale industrial applications of enzymes have replaced or greatly enhanced traditional chemical methods. To fully realize the potential of enzyme-based alternatives it is desirable to have as great an understanding of the physicochemical nature of both enzyme and substrate as possible. The apparent success of xylanase applications in pulp biobleaching applications and the predominant use of softwood species in Canadian pulp mills motivated the current investigation into the production, isolation and characterization of β -mannanase activity. The extracellular β -mannanase activity of *T. harzianum* E58 was shown to be an inducible enzyme system, consisting of multiple forms, whose production was influenced by the carbohydrate substrates present in the growth medium. A protein having β -D-mannanase activity but lacking detectable cellulase activity was identified and isolated. The relatively high pI value of this β -mannanase makes it unique among the fungal β -mannanase characterized to date.

Since β -mannanase activity was stable during 12 months of storage at 4° C, resistant to pepsin, α -chymotrypsin, trypsin, and *Staphylococcus* V8 proteases, not inhibited in solutions of 20% (v/v) ethanol or methanol, and retained in a variety of detergent solutions, β -mannanase 6.55 activity appeared to originate from a very stable region within the protein structure. A further understanding of the nature of this stability

may be gained by studying the molecular structure and chemical composition of the enzyme.

Degradation of β -D-mannans by β -mannanase 6.55 in the presence of celluloses and xylans, as well as the observed increase in reducing sugars in spruce lignin carbohydrate solutions after enzyme treatment, demonstrated the ability of the enzyme to act in the presence of other polysaccharides and wood components. These preliminary results indicate that the enzyme may be of value in treatments designed to selectively hydrolyze β -D-mannans in softwood lignocelluloses.

During the study of *T. harzianum* β -mannanase 6.55 and its production critical questions concerning the structure of β -D-mannans and the lignocellulosic matrix in which these components are usually imbedded have arisen. Identified among the unresolved issues concerning the substrate were; 1) The inability to assess the extent and type of hydrolysis that occurs because of the complex heterogeneity of LLC and the lack of highly defined substrates, 2) The types of conformational changes occurring in the enzyme and the substrate during initial enzyme hydrolysis and what their role in recalcitrance may be, and 3) The nature of the interactions that might occur between β -mannanases and the non-mannan components of the LCC. Enzyme adsorption appears to play a key role in the latter case and merits further investigation.

It is hoped that as more β -mannanases are isolated and characterized, and more defined substrates become available, the role β -mannanases and the associations that they form with other enzymes and carbohydrates will be elucidated and will lead to an effective means of controlling the modification of lignocellulosic materials for use in industrial scale applications.

REFERENCES

- Akino, T., C. Kato, and K. Horikoshi 1989a. The cloned β -mannanase gene from alkalophilic *Bacillus* sp. AM-001 produces two β -mannanases in *Escherichia coli*. Arch Microbiol 152: 10-15.
- Akino, T., C. Kato, and K. Horikoshi 1989b. Two *Bacillus* β -mannanases having different COOH termini are produced in *Escherichia coli* carrying pMAH5. Appl Environ Microb 55: 3178-3183.
- Akino, T., N. Nakamura, and K. Horikoshi 1987. Production of β -mannosidase and β -mannanase by an alkalophilic *Bacillus* sp. Appl Microbiol Biotechnol 26: 323-327.
- Akino, T., N. Nakamura, and K. Horikoshi 1988. Characterization of three β -mannanases of an alkalophilic *Bacillus* sp. Agric Biol Chem 52: 773 - 779.
- Araki, T. 1983. Purification and characterization of an endo- β -mannanase from *Aeromana* sp. F-25. J Fac Agr Kyush Univ 27 (3-4): 89-98.
- Araki, T., and M. Kitamikado 1978. Distribution of mannan-degrading bacteria in aquatic environments. Bull Japanese Soc Sci Fisheries 44: 1135-1139.

- Araki, T., and M. Kitamikado 1988. Exo-1,4- β -mannanase from *Aeromona hydrophila*, In Methods in Enzymology, (W.A. Wood and S.T. Kellogg eds.), Biomass Part A: Cellulose and Hemicellulose, American Chemical Society 160: 583-589.
- Araujo, A., and O.P. Ward 1990a. Extracellular mannanases and galactanases from selected fungi. J Ind Microbiol 6: 171 -178.
- Araujo, A., and O.P. Ward 1990b. Hemicellulases of *Bacillus* species: preliminary comparative studies on production and properties of mannanases and galactanases. J Appl Bacteriol 68: 253-261.
- Araujo, A., and O.P. Ward 1990c. Mannanase components from *Bacillus pumilus*. Appl Environ Microbiol 56 (6): 1954-1956.
- Araujo, A., and O.P. Ward 1990d. Purification and some properties of the mannanases from *Thielavia terrestris*. J Ind Microbiol 6: 269-274.
- Bacon, J.S.D. 1979. Factors limiting the action of polysaccharide degrading enzymes. In Microbiol Polysaccharides and Polysaccharases (R.C.W. Berkeley, G.W. Gooday, and D.C. Ellwood eds.), Academic Press, N. Y. pp 269-284.

- Bewley, J.D., and J.S.G. Reid 1985. Mannans and glucomannans, *In* Biochemistry of Storage Carbohydrates in Green Plants, (P.M. Dey and R.A. Dixon eds.), Academic Press, N.Y. pp 289 - 304.
- Biely, P. 1985. Microbial xylanolytic systems. *Trends Biotechnol* 3: 286-290.
- Biely, P., C.R. MacKenize, J.Puls, and H. Schneider 1986. Cooperativity of esterases and xylanases in the enzymatic degradation of acetyl xylan. *BioTechnol* 4: 731-733.
- Blum, H., H. Beier, and H.J. Gross 1987. Improved silver staining of plant proteins, RNA, DNA in polyacrylamide gels. *Electrophoresis* 8: 93-99.
- Boopathy, R. 1987. Inoculum source for anaerobic fermentation of coffee pulp. *Appl Microbiol Biotechnol* 26: 588-594.
- Boutelje, J., and B.H. Hollmark 1972. Studies with interference microscopy on enzymic hydrolysis of fiber walls. *Holzforschung* 26: 76-81
- Bradford, M. 1976. A rapid and sensitive method for quantification of microgram quantities of protein utilizing the principle of protein-dye binding. *Anal Biochem* 72: 248-254.

- Bremner, I., and K.C.B. Wilke 1971. The hemicelluloses of Bracken partII. A galactoglucomannan. *Carbohydr Res* 20: 193 - 203.
- Breuil, C., and J.N. Saddler 1985. Comparison of the 3,5-dinitrosalicylic acid and Nelson-Somogyi methods of assaying for reducing sugars and determining cellulase activity. *Enzyme Microb Technol* 7: 327-332.
- Brownell, H.H., 1970. Spruce milled wood lignin and lignin-carbohydrate complex: Molecular size and shape and frequency of lignin-carbohydrate linkages. *TAPPI* 53: 1278- 1281.
- Brownell H.H., and J.N. Saddler 1984. Steam explosion pretreatment for enzymatic hydrolysis. *Biotechnol Bioeng Symp* 14: 55-68.
- Brownsey, G., P. Cairns, M. Miles, and V.J. Morris 1988. Evidence for intermolecular binding between xanthan and the glucomannan konjac mannan. *Carbohydr Res* 176: 329 - 334.
- Burgess, J. 1985. An introduction to plant cell development, (Cambridge University Press, Cambridge).
- Canevascini, G. and C. Gattlen 1981. A comparative investigation of various cellulase assay procedures. *Biotechnol Bioeng.* 23: 1573 - 1590.

- Chanzy, H., M. Dubé, R.H. Marchessault, and J.F. Revol 1979. Single crystals and oriented crystallization of ivory nut mannan. *Biopolymers* 18: 887-898.
- Chanzy, H., A. Grosrenaud, J.P. Joseleau, M. Dubé, and R.H. Marchessault 1982. Crystallization behavior of glucomannan. *Biopolymers* 21: 301-311.
- Chen, H.C., and H.E. Grethlein. 1988. Effect of cellulases size reduction on activity and accessibility. *Biotechnol Lett* 10 : 913- 918.
- Chernoglazov, V.M., O.V. Ermolova, and A.A. Klyosov 1988. Adsorption of high-purity endo-1, 4- β -glucanases from *Trichoderma reesei* in components of lignocellulosic materials: cellulose, lignin, and xylan. *Enzyme Microb Technol* 10: 503-507.
- Civas, A., R. Eberhard, P. LeDieet, and F. Petek 1984. Glycosidases induced in *Aspergillus tamarii*: Secreted α -D-galactosidase and β -D-mannanase. *Biochem J* 219: 857-863.
- Clark, T.A., A. MacDonald, S. Archer, D. Steward, and P. Dare 1988. Pulp modification by enzymatic hydrolysis. Report #c144 PAPRO New Zealand, Forest Research Institute New Zealand.

- Clark T.A., A.G. McDonald, D.J. Senior, and P.R. Mayers 1990. Mannanase and xylanase treatments of softwood chemical pulps: Effects on pulp properties and bleachability. *In* Biotechnology in Pulp and Paper Manufacture: Applications and Fundamental Investigations, (T.K. Kirk and H.-M. Chang eds.), Butterworth-Heinemann, Boston, pp 39 - 43.
- Dea, C.M., E.R. Morris, D.A. Rees, E.J. Welsh, H.A. Barnes, and J. Price 1977. Associations of like and unlike polysaccharides: Mechanism and specificity in galacto-mannans, interacting bacterial polysaccharides, and related systems. *Carbohydr Res* 57: 249 - 272.
- Deetz, J.S., and J.D. Rozzell 1988. Enzyme-catalysed reactions in non-aqueous media. *TIBTECH* 6: 15 - 19.
- DeGusseem, R.I., G.M. Aerts, M. Claeysens, and C.K. DeBruyne 1978. Purification and properties of an induced β -D-glucosidase from *Stachybotrys atra*. *Biochim Biophys Acta* 525: 142-153.
- Dekker R.F.H. 1979. The hemicellulase group of enzymes. *In*: Polysaccharides in Food. (J.M.V. Blanshard and J.R. Mitchell eds.), Butterworths, London, pp 93-108.

- Dekker, R.F.H. 1985. Biodegradation of the hemicelluloses. *In* Biosynthesis and Biodegradation of wood components, (T. Higuchi ed.), Academic Press Inc., Orlando. USA pp 505-533.
- Dekker, R.F.H., and G.N. Richards 1976. Hemicellulases: Their occurrence, purification, properties, and mode of action. *Adv Carbohydr Chem Biochem* 32: 277-352.
- Dubois, M., K.A. Giles, J.K. Hamilton, P. Rebers, and F. Smith 1956. Colorimetric determination of sugars and related substances. *Anal Chem* 28: 350 356.
- Ehlers, G.M. 1980. Possible applications of enzymes in coffee processing, *In* Proc 9th Colloq ASIC, June 1980, London England.
- Emi, S., J. Fukumoto, and T. Yamamoto 1972. Crystallization and some properties of mannanase. *Agr Biol Chem* 36: 991-1001
- Eriksson, K.-E. 1979. Biosynthesis of polysaccharides, *In* Microbial Polysaccharides and Polysaccharidases, (R.C.W. Berkeley, G.W. Gooday and D.C. Ellwood eds.), Academic Press N.Y. pp 285 - 293.

- Eriksson, K.-E., R.A. Blanchette, and P. Ander 1990. Microbial and enzymatic degradation of wood and wood components, Springer-Verlag Berlin
- Eriksson, K.-E., and B. Pettersson 1982. Purification and partial characterization of two acidic proteases from the white-rot fungus *Sporotrichum pulverulentum*. Eur J Biochem 124: 635-642.
- Eriksson, K.E., and M. Winell 1968. Purification and characterisation of a fungal β -mannanase. Acta Chemica Scandinavica 22: 1924-1934.
- Eveleigh, D.E. 1985. Trichoderma, *In* Biology of Industrial Microorganisms (Arnold L. Demain and Nadine A. Solomon eds., The Benjamin/Cummings Publishing Company Inc. London) pp 487-509.
- Fengel, D., and G. Wegener 1983. Wood: Chemistry, ultrastructure, reactions. Walter de Gruyter and Co., Berlin.
- Firantas, S.-G.A., I.Y. Venzhinskene and A.B. Pailyukonis 1983. Determination of β -mannanase activity by the viscosimetric and spectrophotometric methods. All-union Science Research Institute of Applied Enzymology, Vilnius. pp 461-466, *Translated from Prikladnaya Biokhimiya i Mikrobiologiya* 18 (4): 581-587.

- Gherardini, F.C., and A.A. Salyers 1987a. Characterization of an outer membrane mannanase from *Bacteroides ovatus*. *J Bact* 169: 2031-2037.
- Gherardini, F.C., and A.A. Salyers 1987b. Purification and characterization of a cell-associated, soluble mannanase from *Bacteroides ovatus*. *J Bacteriol* 169: 2038-2043.
- Ghose, T.K. 1987. Measurement of cellulase activities. *Pure Appl Chem* 59: 257-268.
- Ghose T.K., and V.S. Bisaria 1979. Studies on the mechanism of enzymatic hydrolysis of cellulosic substances. *Biotechnol Bioeng* 21: 131-146.
- Ghose, T.K., T. Panda, and V.S. Bisaria 1985. Effect of culture phasing and mannanase on production of cellulase and hemicellulase by mixed culture of *Trichoderma reesei* D 1-6 and *Aspergillus wentii* Pt 2804. *Biotechnol Bioeng* 27: 1353-1361.
- Gilbert, I.G., and G.T. Tsao 1983. Interaction between solid substrate and cellulase enzymes in cellulose hydrolysis. *Ann Rep Fermentation Processes* 6: 323-358.

- Goodwin, T.W. 1983. Introduction to Plant Biochemistry, 2nd ed., Pergamon Press Ltd., Willowdale Ontario.
- Grohmann, K., D.J. Mitchell, M.E. Himmel, B.E. Dale, and H.A. Schroeder 1989. The role of ester groups in resistance of plant cell wall polysaccharides to enzymatic hydrolysis. *Appl Biochem Biotechnol* 20: 45-61.
- Gupta, A.K., and H. Grasdalen 1988. A D-galacto-D-mannan from *Melilotus officinolis* seeds. *Carbohydr Res* 173: 159-168.
- Haemmerli, S.D., M.S. Leisola, and A. Fiechter 1986. Polymerization of lignins by ligninases from *Phanerocheate chrysosporium*. *FEMS Lett* 35: 33-36.
- Hagspiel, K., D. Haab and C.P. Kubicek 1989. Protease activity and proteolytic modification of cellulases from a *Trichoderma reesei* QM 9414 selectant. *Appl Microbiol Biotechnol* 32: 61-67.
- Håkansson, U., L. Fägerstam, G. Pettersson, and L. Andersson 1978. Purification and characterization of a low molecular weight 1,4- β -glucan glucanohydrolase from the cellulolytic fungus *Trichoderma viride* QM 9414. *Biochem Biophys Acta* 524: 385 - 392.

- Halliwell, G. 1979. Microbial β -glucanases. *Prog Indust Microbiol* 15:1 -60.
- Harada, H., and W.A. Cote 1985. Structure of Wood *In* Biosynthesis and Biodegradation of wood components, (T. Higuchi ed.), Academic Press Inc., Orlando. USA pp 1-42.
- Hashimoto, Y., and J. Fukumoto 1969. Studies on the enzyme treatment of coffee beans Part I. Purification of mannanase of *Rhizopus niveus* and its action on coffee mannan. *Nippon Nōgeikagaku Kaishi* 43 : 317 - 322.
- Heukeshoven, J., and R. Dernick 1985. Simplified method for silver staining of proteins in polyacrylamide gels and the mechanism of silver staining. *Electrophoresis* 6: 103-112.
- Heyne, E., and R.L. Whistler 1948. Chemical composition and properties of guar polysaccharides. *J Amer Chem Soc* 70: 2249-2252.
- Highley, T.L. 1987. Changes in chemical components of hardwood and softwood by brown-rot fungi. *Mater und Organismen* 22 (1): 39-45.
- Highley, T.L., K.E. Wolter, and F.J. Evans 1981. Polysaccharide-degrading complex produced in wood and in liquid media by the brown-rot fungus *Poria placenta*. *Wood and Fiber* 13 (4): 265-274.

- Hinck, J.F., R.L. Casebier, and J.K. Hamilton 1985. Dissolving Pulp Manufacture. ITT Rayoneir Inc., Publication #239., Shelton WA.
- Hoffman, P., and N. Parameswaran 1976. On the ultrastructural localization of hemicelluloses within delignified tracheids of spruce. *Holzforschung* 30: 62-70.
- Hori, H., and A.D. Elbein 1985. Biosynthesis of plant cell wall polysaccharides, *In* Biosynthesis and Biodegradation of Wood Components (T. Higuchi ed.), Academic Press Inc., Toronto. pp 109-140.
- Hrmová, M., P. Biely, and M. Vrsanska 1986. Specificity of cellulase and β -xylanase induction in *Trichoderma reesei* QM 9414. *Arch Microbiol* 144: 307-311.
- Hudson, H.J. 1980. Fungal Saprophytism 2nd ed., Edward Arnold Ltd., London.
- Ishihara M., and K. Shimizu 1980. Hemicellulases of brown-rotting fungus *Tyromyces palustris* IV: Purification and some properties of an extracellular mannanase. *Mokuzai Gakkaishi* 26: 811-818.
- Johnson, K.G. 1990. Exocellular β -mannanases from hemicellulolytic fungi. *MIRCEN* 6: 209-217.

- Johnson, K.G., B.A. Harrison, H. Schneider, C.R. MacKenzie, and J.D. Fontana 1988. Xylan-hydrolyzing enzymes from *Streptomyces* spp.. *Enz Microb Technol* 10: 403-409.
- Johnson, K.G., and N.W. Ross 1990. Enzymic properties of β -mannanase from *Polyporus versicolor*. *Enzyme Microb Technol* 12: 960-964.
- Johnson, K.G., N.W. Ross, and H. Schneider 1990. Purification and some properties of β -mannanases from *Polyporus versicolor*. *J MICREN* 6 : 245-254.
- Johnson, K.G., M.C. Silva, C.R. Mackenzie, H. Schneider, and J.D. Fontana 1989. Microbial degradation of hemicellulosic materials. *Appl Biochem Biotechnol* 20/21: 245- 248.
- Kalra. M.K., M.S. Sidhu, D.K. Sandu, and R.S. Sandu 1984. Production and regulation of cellulases in *Trichoderma harzianum*. *Appl Microb Biotechnol* 20: 427-429.
- Kaneko, R., I. Lusakabe, Y. Sakai, and K. Murakami 1990. Substrate specificity of α -galactosidase from *Mortierella vinacea*. *Agric Biol Chem* 54 : 237 - 238.

Kantelinen A., M. Rättö, J. Sundquist, M. Ranua, L. Viikari, and M. Linko
1988. Hemicellulases and their potential role in bleaching. *In Proc 1988
Tappi Bleaching Conference*, Tappi Press, pp 1-9.

Kato, K., and K. Matsuda 1972. Studies on the Chemical Structure of Konjac
Mannan Part III. Theoretical aspect of controlled degradation of the main
chain of the mannan. *Agr Biol Chem* 36(4): 639-644.

Kendrick, B. 1985. *The Fifth Kingdom*. Mycologue Publications, Waterloo,
Canada.

Khan, A.W., K.A. Lamb, and K.G. Johnson 1989. Formation of enzymes
required for the hydrolysis of plant cell wall polysaccharides by
Trichoderma reesei. *MIRCEN J* 5: 49-54.

Kierulf, C., and I.W. Sutherland 1988. Thermal stability of xanthan preparations.
Carbohydr Polymers 9:185 - 194.

Klibanov, A.M. 1986. Enzymes that work in organic solvents. *CHEMTECH*
(June) pp 354-359.

- Knapp, J.S., and M. Legg 1986. The effect of different cellulosic growth substrates and pH on the production of cellulolytic enzymes by *Trichoderma reesei*. J Appl Bacteriol 61: 319-329.
- Kusakabe, I., R. Takahashi, K. Murakami, A. Maekawa, and T. Suzuki 1983. Preparation of crystalline β -1,4- mannoooligosaccharides from copra mannan by mannanase from *Streptomyces*. Agric Biol Chem 47: 2391-2392.
- Kyriacou, A., R.J. Neufeld, and C.R. Mackenzie 1988. Effect of physical parameters on the adsorption characteristics of fractionated *Trichoderma reesei* cellulase components. Enzyme Microb Technol 10: 675-681.
- Kyriacou, A., R.J. Neufeld, and C.R. Mackenzie 1989. Reversibility and competition in the adsorption of *Trichoderma reesei* cellulase components. Biotech Bioeng 33: 631-637.
- Lehninger, A. 1975. Biochemistry, Worth Publishers Inc., New York.
- Levin, R.A. 1974. Biochemical taxonomy, *In* Algal Physiology and Biochemistry (W.D. Stewart ed.), University of California Press, Berkeley. pp 12 -13.

- Lyr, H. 1963. Über das Vorkommen von Mannanase bei Pilzen. *Zeitschrift für Allg Mikrobiol* **3**: 25-36.
- Mackie, W., and R.D. Preston 1974. Cell wall and intercellular region polysaccharides, *In Algal Physiology and Biochemistry* (W.D. Stewart ed.), University of California Press, Berkeley. pp 53 - 54.
- Maekajji, K. 1974. The mechanism of gelation of konjac mannan. *Agric Biol Chem* **34**: 315 - 321.
- Mandels, M. 1982. Cellulases, *In Annual Report of the Fermentation Proceedings* (G. Tsao ed.), Academic Press Inc., N. Y. vol **5**: 35-78.
- Mandels, M., R. Andreotti, and C. Roche 1976. Measurement of saccharifying cellulose. *Biotechnol Bioeng Symp* **6**: 2-34.
- McCleary, B.V. 1979a. Enzymatic hydrolysis, fine structure, and gelling interaction of legume-seed D-galacto-D-mannans. *Carbohydr Res* **71**: 205-230.
- McCleary B.V. 1979b. Modes of action of β -mannanase enzymes of diverse origin on legume seed galactomannans. *Phytochem* **18**: 757-763.

- McCleary, B.V. 1983a. β -D- Mannanase from *Helix pomatia*. Carbohydr Res 111: 297-310.
- McCleary, B.V. 1983b. Enzymic interactions in the hydrolysis of galactomannan in germinating guar: The role of exo- β -mannanase. Phytochem 22: 649-658.
- McCleary, B.V. 1986. Enzymatic modification of plant polysaccharides. Int J Biol Macromol 8: 349- 354.
- McCleary, B.V. 1988a. β -D-Mannanases, *In* Methods in Enzymology: Biomass Part A Cellulose and Hemicellulose, (W.A. Wood and S.T. Kellogg eds.), Academic Press Inc., Vol. 160: 596-610.
- McCleary, B.V. 1988b. Carob and guar galactomannans, *In* Methods in Enzymology: Biomass Part A Cellulose and Hemicellulose, (W.A. Wood and S.T. Kellogg eds.), Academic Press Inc., Vol. 160: 523-528.
- McCleary, B.V. 1988c. Exo- β -D-mannanase from *Cyamopsis tetragonolobus* guar seed, *In* Methods in Enzymology: Biomass Part A Cellulose and Hemicellulose, (W.A. Wood and S.T. Kellogg eds.), Academic Press Inc., Vol. 160: 585-597.

- McCleary, B.V. 1988d. Soluble dye-labelled polysaccharides for assay of endohydrolases, *In Methods in Enzymology*: (W.A. Wood and S.T. Kellogg eds.), Biomass Part A Cellulose and Hemicellulose, American Chemical Society., Vol 160: 74-86.
- McCleary, B.V. 1988e. Synthesis of β -D-mannopyranosides for the assay of β -D-mannosidase and exo- β -D-mannanase, *In Methods in Enzymology*: Biomass Part A Cellulose and Hemicellulose, (W.A. Wood and S.T. Kellogg eds.), Academic Press Inc., Vol. 160: 515-517.
- McCleary, B.V. 1991. Comparison of endolytic hydrolases that depolymerize 1,4- β -D-mannan, 1,5- α -L-arabinan, and 1,4- β -D-galactan, *In Enzymes in Biomass Conversion*, (G. F. Leatham and M. E. Himmel eds.,) American Chemical Society, Washington D..C., pp 435 - 449.
- McCleary, B.V. and N.K. Matheson 1975. Galactomannan structure and β -mannanase and β -mannosidase activity in germinating legume seeds. *Phytochem* 14: 1187-1194.
- McCleary, B.V. and N.K. Matheson 1983. Action patterns and substrate-binding requirements of β -D-mannanase with mannosaccharide and mannan-type polysaccharides. *Carbohydr Res* 119: 191-219.

- McCleary, B.V. and N.K. Matheson 1986. Enzymic analysis of polysaccharide structure. *Adv Carbohydr Chem Biochem* 44: 147 - 276.
- McCleary, B.V., E. Nurthen, F.R. Taravel, and J.-P. Joseleau 1983. Characterization of the oligosaccharides produced on hydrolysis of galactomannan with β -D-mannanase. *Carbohydr Res* 118: 91-109.
- McDonald, A. 1987. Hemicellulose extraction from *Pinus radiata*. Forest Research Institute Report #1710.
- McNeely, W.H., and K.S. Kang 1973. Xanthan and some other biosynthetic gums, *In Industrial Gums: polysaccharides and their derivatives*, 2nd ed., (R.L. Whistler and J.N. DeMiller eds.), Academic Press N.Y. pp 474-498.
- Meier, H. 1985. Localization of polysaccharides in wood cell walls *In Biosynthesis and Biodegradation of Wood Components* (T. Higuchi ed.), Academic Press Inc., NY pp 43-50.
- Meier, H., and J.S.G. Reid 1982. Reserve polysaccharides other than starch in higher plants. *In Encyclopedia of Plant Physiology, New Series*, 13A (F.A. Loewus and W. Tanner eds.), pp 418-471, Springer-Verlag, Berlin.

- Mes-Hartree, M., C.M. Hogan, and J.N. Saddler 1988. Influence of growth substrate on production of cellulase enzymes by *Trichoderma harzianum* E58. *Biotechnol Bioeng* 31: 725-729.
- Miller, G.L. 1959. Use of dinitrosalicylic acid reagent for determination of reducing sugar. *Anal Chem* 31:426-428.
- Montenecourt, B.S., and D.E. Eveleigh 1977. Preparation of mutants of *Trichoderma reesei* with enhanced cellulase production. *Appl Environ Microbiol* 34: 777-784.
- Muller, G., and J. Lecourtier 1988. Temperature-induced extension and dissociation of native xanthan. *Carbohydrate Polymers* 9: 213-225.
- Nakajima, T., and C.E. Ballou 1974. Characterization of the carbohydrate fragments obtained from *Saccharomyces cerevisiae* mannan by alkaline degradation. *J Biol Chem* 249: 7679-7684.
- Neidleman, S.L. 1990. Enzyme reactions under stress conditions. *CRC Critical Reviews in Biotechnol* 9 (4): 273-286.

- Neville, A.C. 1988. A pipe-cleaner molecular model for morphogenesis of helicoidal plant cell walls based on hemicellulose complexity. *J Theor Biol* 131: 243-254.
- Noe, P. J., Chevalier, F. Mora, and J. Comtat 1986. Action of xylanases on chemical pulp fibers. Part II. Enzymatic beating. *J Wood Chemistry Technol* 6: 167-184.
- Ogawa, M., J. Katou, T. Ariga, M. Nakajima and M. Natori 1987. Partial purification of extracellular konjac-glucomannan decomposing enzyme from *Bacillus circulans* No. 215 by affinity chromatography. *Nippon Shokuhin Kogyo Gakkoishi* 34 (8): 520-523.
- Overend, R., and K.G. Johnson 1991. Lignin-carbohydrate complexes from poplar wood: Isolation and enzymatic degradation, *In* *Enzymes in Biomass Conversion*, (G.F. Leatham and M.E. Himmel eds.,) American Chemical Society, Washington D.C., pp 270 - 287.
- Paice, M.G., and L. Jurasek 1984. Removing hemicellulose from pulps by specific enzymatic hydrolysis. *J Wood Chem Technol* 4(2): 187-198.

- Paice, M.G., R. Bernier, and L. Jurasek 1988. Viscosity-enhancing bleaching of hardwood kraft pulp with xylanase from a cloned gene. *Biotechnol Bioeng* 32: 235-239.
- Park, G.G., I. Kusakabe, Y. Komatsu, H. Kobayashi, T. Yasui, and K. Murakami 1987. Purification and some properties of β -mannanase from *Penicillium purpurogenum*. *Agric Biol Chem* 51: 2709-2716.
- Poulsen, O.M., and L.W. Petersen 1989. Growth and enzyme production of *Cellulomonas* spp. ATCC 21399 on microcrystalline cellulose: Effects of increasing concentration of a mineral medium. *Appl Microbiol Biotechnol* 30: 535-539.
- Poutanen, K., M. Rättö, J. Puls, and L. Viikari 1987. Evaluation of different microbial xylanolytic systems. *J. Biotechnol* 6: 49-60.
- Poutanen, K., and M. Sundberg 1988. An acetyl esterase of *Trichoderma reesi* and its role in the hydrolysis of acetyl xylans. *Appl Microbiol Biotechnol* 28: 419-424.
- Rapp, P., H. Reng, and D.-C. Hempel 1984. Cellulose degradation and monitoring of viscosity decrease in cultures of *Cellulomonas uda* grown in cultures of printed newspaper. *Biotechnol Bioeng* 26: 1167-1175.

- Rättö, M., and K. Poutanen 1988. Production of mannan-degrading enzymes. *Biotechnol Lett* 10 (9): 661-664.
- Rees, D.A. 1977. *Polysaccharide Shapes (Outline Studies in Biology)* Chapman and Hall Ltd, London.
- Reese E.T., and Y. Shibata 1965. β -Mannanases of fungi. *Can J Microbiol* 11: 167-183
- Rol, F. 1973. Locust bean gum, *In Industrial Gums: Polysaccharides and their derivatives*, 2nd ed., (R.L. Whistler and J.N. DeMiller eds.), Academic Press N.Y., pp 323-337.
- Ross, N.W., K.G. Johnson, C. Braun, C.R.E. MacKenzie, and H. Schneider 1991. Enzymic hydrolysis of water-soluble lignin-carbohydrate complexes from *Populus deltoides*: Effects of combinations of β -mannanases, xylanase and acetyl xylan esterase. *Enz Microb Tech* (in Press).
- Ryu, D.D.Y., C.Kim, and M. Mandels 1984. Competitive adsorption of cellulase components and its significance in a synergistic mechanism. *Biotechnol Bioeng* 26: 488-496.

Saddler, J.N. 1982. Screening of highly cellulolytic fungi and the action of their cellulase enzyme systems. *Enzyme Microb Technol* **4**: 414-418.

Saddler, J.N., and M. Mes-Hartree 1984. The enzymatic hydrolysis and fermentation of pretreated wood substrates. *Biotechnol Adv* **2**: 161-181.

Schwald, W., H.H. Brownell, and J.N. Saddler 1988. Enzymatic hydrolysis of steam treated aspen wood: Influence of partial hemicellulose and lignin removal prior to pretreatment. *J Wood Chem Technol* **8**: 543-560.

Scopes, R.K. 1985. *Protein Purification; Principles and Practices*, 2nd ed., Springer-Verlag, New York.

Senior, D.J., P.R. Mayers, D. Miller, R. Sutcliffe, L. Tan, and J.N. Saddler 1988. Selective solubilization of xylan in pulp using a purified xylanase from *Trichoderma harzianum*. *Biotech Lett* **10** (12): 907-912.

Senior, D.J., P.R. Mayers, and J.N. Saddler 1989a. Production and purification of xylanases. In: *Plant cell wall polymers: Biogenesis and Biodegradation*, (N.G. Lewis and M.G. Paice, eds.), ACS Symp. Series No. 399, Amer Chem Soc, pp 641-654.

Senior, D.J., P.R. Mayers, and J.N. Saddler 1989b. Xylanase production by *Trichoderma harzianum* E58. *Appl Microbiol Biotechnol* 32: 137-142.

Senoir, D.J., P.R. Mayers, C. Breuil, and J.N. Saddler 1990. Interaction of xylanase with pulp: Non-selective adsorption and inactivation of xylanase, *In* *Biotechnology in Pulp and Paper Manufacture: Applications and Fundamental Investigations*, (T.K. Kirk and H.-M. Chang eds.), Butterworth-Heinemann, Boston, pp 169-182.

Senior, D.J., P.R. Mayers, and J.N. Saddler 1991. The interaction of xylanases with commercial pulps. *Biotechnol Bioeng* 37: 274-279.

Shami, E.Y., A. Rothstein, and M. Ramjeesingh 1989. Stabilization of biologically active proteins. *TIBTECH* 7: 186-190.

Shatwell, K.P., I.W. Sutherland, S.B. Ross-Murphy, and I.C. Dea 1991a. Influence of the acetyl substituent on the interaction of xanthan with plant polysaccharides - III. Xanthan-guar gum systems. *Carbohydr Polymers* 14: 115 - 130.

- Shatwell, K.P., I.W. Sutherland, S.B. Ross-Murphy, and I.C. Dea 1991b.
Influence of the acetyl substituent on the interaction of xanthan with plant polysaccharides - III. Xanthan-konjac mannan systems. Carbohydr Polymers 14 : 131 - 147.
- Shatwell, K.P., I.W. Sutherland, S.B. Ross-Murphy, and I.C. Dea 1991c.
Influence of the acetyl substituent on the interaction of xanthan with plant polysaccharides - III. Xanthan-locust bean gum systems. Carbohydr Polymers 14 : 29 -51.
- Shimizu, K., and M. Ishihara 1983. Isolation and characterization of oligosaccharides from the hydrolyzate of Larchwood glucomannan with endo-B-D-mannanase. Agric Biol Chem 47: 949-955.
- Sinner, M., N. Parameswaran, V.N. Yamazaki, W. Liese, and H.H. Dietrichs 1976. Specific enzymatic degradation of polysaccharides in delignified wood cell walls. Applied Polymer Symposium 28: 993-1024.
- Sinner M., N. Parameswaran, and H.H. Dietrichs 1979. Degradation of delignified sprucewood by purified mannanase, xylanase and cellulases. Adv Chem Series 181: 303-329

- Sjöström, E. 1981. Wood Chemistry: Fundamentals and Applications, Academic Press, Toronto.
- Smith, F. and H.C. Srivastava 1959. Constitutional studies on the glucomannan of konjak flour. J Amer Chem Soc 81: 1715-1718.
- Somogyi, M. 1952. Notes on sugar determination. J Biol Chem 195: 19-23.
- Souw, P., and H.J. Rehm 1975. Microorganisms in Gums v. Degradation of the galactomannans guar gum and locust bean gum by different Bacilli. Eur J Appl Microbiol 2: 47-58.
- Ståhlberg, J., G. Johansson, and G. Pettersson 1991. A new model for enzymatic hydrolysis of cellulose based on the two-domain structure of cellobiohydrolase I. BioTech 9: 286 -290.
- Sutcliffe, R., and J.N. Saddler 1986. The role of lignin in the absorption of cellulases during enzymatic treatment of lignocellulosic material. Biotechnol Bioeng Sym 17: 751-762.
- Sutherland, I.W. 1984. Hydrolysis of unordered xanthan in solution by fungal cellulases. Carbohydr Res 131: 93 - 104.

- Takahashi R, I. Kusakabe, H. Kobayashi, K. Murakami, A. Maekawa, and T. Suzuki 1983. Studies on mannanase of Actinomycetes I. Some Properties of Extracellulases. *Japan J Trop Agric* 27: 140-148.
- Takahashi R, I. Kusakabe, H. Kobayashi, K. Murakami, A. Maekawa, and T. Suzuki 1984. Purification and some properties of mannanase from *Streptomyces* sp.. *Agric Biol Chem* 48: 2189-2195.
- Talbot, G., and J. Sygusch 1990. Purification and characterization of thermostable β - mannanase and α -galactosidase from *Bacillus stearothermophilus*. *Appl Environ Microbiol* 56: 3505 - 3510.
- TAPPI 1989. Test method T222 os-74, *In* vol 1, Chemical Properties Committee Process and Product Development Division, Chairman, J.C. Abott, TAPPI press, Atlanta, Georgia, USA
- Tan L.L., P.R. Mayers, M. Illing, and J.N. Saddler 1987. The copurification of β -glucosidase, β -xylosidase and β -1,3-glucanase in the two separate enzyme complexes isolated from *Trichoderma harzianum*. *Biochem Cell Biol* 65: 822-832.

- Tan, L.U.L., K.K.Y. Wong, and J.N. Saddler 1985a. Functional characteristics of two xylanases purified from *Trichoderma harzianum*. *Enzyme Microb Technol* 7: 431-436.
- Tan, L.U.L., K.K.Y. Wong, and J.N. Saddler 1985b. Purification and characterization of two D-xylanases from *Trichoderma harzianum*. *Enzyme Microb Technol* 7:425-430.
- Tatsumoto, K., J.O. Baker, M.P. Tucker, K.K. Oh, A. Mohagheghi, K. Grohmann, and M.E. Himmel 1988. Digestion of pretreated aspen substrates: Hydrolysis rates and absorptive loss of cellulase enzymes. *Appl Biochem Biotechnol* 18: 159 - 174.
- Tilbeurgh, H. van, P. Tomme, M. Claeysseus, R. Bhikhabhai, and G. Petterson 1986. Limited proteolysis of the cellobiohydrolase I from *Trichoderma reesi*. *FEBS Lett* 204:223-227.
- Timell, T.E. 1961. Isolation of galactoglucomannans from the wood of gymnosperms. *Tappi* 44: 88-96.
- Timell, T.E. 1965. Galactoglucomannans from the wood of gymnosperms *In* *Methods in Carbohydrate Chemistry* (Whistler, Roy L., James N. BeMiller and M.L. Wolfrom eds.), Academic Press N.Y. 5: 134-137.

Timell, T.E. 1967. Recent progress in the chemistry of wood hemicelluloses. *Wood Sci Technol* 1: 45-70.

Timell, T.E. 1982. Recent progress in the chemistry and topochemistry of compression wood. *Wood Sci Technol* 16: 83-122.

Tomme, P., H., van Tiibeurgh, G. Petterson, J. van Damme, J. Vandekerckhove, J. Knowles, T. Teeri, and M. Claeysens 1988. Studies of the cellulolytic system of *Trichoderma reesei* QM9414: Analysis of domain function in two cellobiohydrolases by limited proteolysis. *Eur J. Biochem* 170: 575-581.

Torrie, J., D. Senior, and J.N. Saddler 1991. Production of β -mannanases by *Trichoderma harzianum* E58. *Appl Microbiol Biotechnol* 34: 303-307.

Ülker, A., and B. Sprey 1989. Production and characterization of an unglycosylated low molecular weight 1, 4- β -glucanohydrolyase of *Trichoderma reesei*, In *Trichoderma reesei* Cellulases: Biochemistry, Genetics, Physiology and Application (C.P. Kubicek, D.E. Eveleigh, H. Estetbauer, W. Steiner, and E.M. Kubicek-Pranz eds.), Royal Society of Chemistry, Cambridge pp 60- 80.

- Urbanek H., J. Zalewsko-Sobezak, and A. Borowinska 1978. Isolation and properties of extracellular cellulase-hemicellulase complex of *Phoma hibernica*. *Archiv Microbiol* 118: 265-269.
- Urbanek, H., and J. Zalewsko-Sobezak 1988. Cellulases-hemicellulase complex of *Phoma hibernica*. *In* *Methods in Enzymology: Biomass Part A Cellulose and Hemicellulose*, (W.A. Wood and S.T. Kellogg eds.), Academic Press Inc., Vol. 160: 5589-597.
- Uziie, M., M. Matsuo, and T. Yasui 1985. Purification and some properties of *Chaetomium trilaterale* β -xylosidase. *Agric Biol Chem* 49: 1159-1166.
- Vian, B. and D. Reis 1987. Molecular shape and cytochemical characterization of hemicelluloses from higher plant cell walls. *Food Hydrocolloids* 1: 557-558.
- Viikari, L., A. Kantelinen, M. Rättö, and J. Sundquist 1991. Enzymes in pulp and paper processing, *In* *Enzymes in Biomass Conversion*, (Gary F. Leatham and Michael E. Himmel eds.,) American Chemical Society, Washington D..C., pp 12 - 21.

- Viikara, L., M. Ranua, A. Kantelinen, M. Linko, and J. Sundquist 1987. Application of Enzymes in Bleaching. *In Proceedings of the International Symposium of Wood Pulping Chemistry*, 1: 151- 154, TAPPI Press.
- Wilke, K.C. 1979. The hemicelluloses of grasses and cereals. *Adv Carbohydr Chem* 36: 215-264.
- Williams, A.G., and C.G. Orpin 1987. Polysaccharide-degrading enzymes formed by three species of anaerobic rumen fungi grown on a range of carbohydrate substrates. *Can J Microbiol* 33: 418-426.
- Winter, W.T., B.K. Song, and H. Bouckris 1987. Structural studies on galactomannans and their complexes. *Food Hydrocolloids* 1: 581-582.
- Wolfrom, M.L., M.L. Laver, and D.L. Patin 1961. Carbohydrates of the coffee bean. II. Isolation and Characterization of a mannan. *J Org Chem* 26 : 4533-4535.
- Wolter, K.E., T.L. Highley, and F.J. Evans 1980. A unique polysaccharide- and glycoside-degrading enzyme complex from the wood-decay fungus *Poria placenta*. *Biochem Biophys Res Comm* 97 (4): 1499-1504.

- Wong, K.Y., L.U.L. Tan, and J.N. Saddler 1986. Purification of a third distinct xylanase from the xylanolytic system of *Trichoderma harzianum*. *Can J Microbiol* 32: 570-576.
- Wong, K.Y., L.U.L. Tan, and J.N. Saddler 1988. Multiplicity of β -1,4-xylanase in microorganisms: Functions and Applications. *Microbiol Reviews* 52 (3).
- Wood, P. J. 1980. Specificity in the interaction of direct dyes with polysaccharides. *Carbohydr Res* 85: 271-287.
- Wood, T.M., and S.I. McCrae 1986. Studies of two low-molecular-weight endo(1,4)- β -D-xylanases constitutively synthesized by the cellulolytic fungus *Trichoderma koningii*. *Carbohydr Res* 148: 321-330.
- Wozniowski, T., W. Blaschek, and G. Franz 1990. Isolation and structure analysis of a glucomannan from the leaves of *Aloe arborescens* var. Miller. *Carbohydr Res* 198 :387 - 391.
- Yamaura, I., T. Matsumoto, M. Funatsu, and Y. Funatsu 1990. Purification and some properties of endo-1,4- β -D-mannanase from *Pseudomonas* sp. PT-5. *Agric Biol Chem* 54: 2425-2427.

Yamazaki, V.N., and H.H. Dietrichs 1979. Die wirkungsweise einer gereinigten endo-1,4-B-mannanase auf galactomannan aus guar. *Holzforschung* 33: 36-42.

Yamazaki, V.N., M. Sinner, and H.H. Dietrichs 1976. Isolierung und Eigenschaften einer β -1,4-Mannanase aus *Aspergillus niger*. *Holzforschung* 30: 101-109.