

## INFORMATION TO USERS

This manuscript has been reproduced from the microfilm master. UMI films the text directly from the original or copy submitted. Thus, some thesis and dissertation copies are in typewriter face, while others may be from any type of computer printer.

**The quality of this reproduction is dependent upon the quality of the copy submitted.** Broken or indistinct print, colored or poor quality illustrations and photographs, print bleedthrough, substandard margins, and improper alignment can adversely affect reproduction.

In the unlikely event that the author did not send UMI a complete manuscript and there are missing pages, these will be noted. Also, if unauthorized copyright material had to be removed, a note will indicate the deletion.

Oversize materials (e.g., maps, drawings, charts) are reproduced by sectioning the original, beginning at the upper left-hand corner and continuing from left to right in equal sections with small overlaps.

ProQuest Information and Learning  
300 North Zeeb Road, Ann Arbor, MI 48106-1346 USA  
800-521-0600

UMI<sup>®</sup>





Université d'Ottawa • University of Ottawa



**The Roles of the Carboxyl-terminal regions of Phospholipid Transfer  
Protein (PLTP) and Cholesteryl Ester Transfer Protein (CETP) in  
Lipid Transfer**

**Stephanie Walter**

Submitted to the School of Graduate Studies in Partial Fulfillment of the Requirements  
for the Degree of Masters of Science

Department of Biochemistry, Microbiology, and Immunology  
Faculty of Medicine  
University of Ottawa

December, 2002

© Stephanie Walter, Ottawa, Canada, 2002



National Library  
of Canada

Acquisitions and  
Bibliographic Services

395 Wellington Street  
Ottawa ON K1A 0N4  
Canada

Bibliothèque nationale  
du Canada

Acquisitions et  
services bibliographiques

395, rue Wellington  
Ottawa ON K1A 0N4  
Canada

*Your file Votre référence*

*Our file Notre référence*

The author has granted a non-exclusive licence allowing the National Library of Canada to reproduce, loan, distribute or sell copies of this thesis in microform, paper or electronic formats.

The author retains ownership of the copyright in this thesis. Neither the thesis nor substantial extracts from it may be printed or otherwise reproduced without the author's permission.

L'auteur a accordé une licence non exclusive permettant à la Bibliothèque nationale du Canada de reproduire, prêter, distribuer ou vendre des copies de cette thèse sous la forme de microfiche/film, de reproduction sur papier ou sur format électronique.

L'auteur conserve la propriété du droit d'auteur qui protège cette thèse. Ni la thèse ni des extraits substantiels de celle-ci ne doivent être imprimés ou autrement reproduits sans son autorisation.

0-612-76551-2

## Abstract

In human plasma, there are two lipid transfer proteins that play major roles in lipoprotein metabolism and reverse cholesterol transport. Cholesterol ester transfer protein (CETP) transfers neutral lipids, and is responsible for all of the plasma cholesteryl ester (CE) and triglyceride (TG) transfer activity. Both CETP and phospholipid transfer protein (PLTP) can facilitate the exchange of phospholipid (PL) among lipoproteins, but only PLTP mediates net mass PL transfer. Residues at the carboxy termini of CETP and PLTP have been shown to be essential for protein function. In order to examine the roles of the C-termini of CETP and PLTP in determining lipid specificity, we have expressed and characterized chimeric proteins in which the C-termini of PLTP and CETP are exchanged. The chimeras CETP<sub>1-460</sub>/PLTP<sub>445-476</sub> (CP), CETP<sub>1-460</sub>/PLTP<sub>445-476</sub>-mycHIS (CP-HIS), and PLTP<sub>1-444</sub>/CETP<sub>461-476</sub> (PC) were secreted from COS-7 cells, indicating that the overall fold of the proteins was not disturbed. The proteins CP, CPHIS, and PC each had less than 10% of the CE and TG transfer activities of CETP. The proteins CP and CPHIS each had less than 10% of the PLTP-specific PL transfer activity of PLTP. These results suggest that the carboxy-termini of CETP and PLTP act in concert with other parts of the molecule to facilitate lipid transfer. Another goal of this research was to produce and characterize a panel of monoclonal antibodies (mAbs) to human PLTP. Attempts to produce mAbs in mice using protein immunization were unsuccessful, but PLTP-specific antibodies were detected in serum from mice immunized with plasmid DNA encoding the human PLTP sequence.

## Acknowledgements

First and foremost, I would like to thank my supervisor and mentor, Dr. Ross Milne. Throughout my time at the Heart Institute, he has given me independence, confidence, and guidance, in both work and other aspects of life. I would also like to thank my committee members, Dr. Ruth McPherson and Dr. Steve Evans for their input and assistance. Many past and present members of the lipoprotein and atherosclerosis group helped me along the way, in particular: Dr. Valerie Guyard-Dangremont, for getting me started on PLTP, Ann Nguyen and Vivian Franklin for their technical skills, Suzanne Davenport for her work on the monoclonal antibodies, Dr. Gerard Vassiliou for his clear explanations and his generous donations of time and assistance preparing labeled lipoproteins, Shermin Rahimkhani for his different perspectives and many shared coffee breaks, Reema Harish for her help during the summers, and Anna Toma for dealing with all the administrative business. My work was funded by scholarships from the Natural Sciences and Engineering Research Council of Canada (NSERC) and the University of Ottawa. And finally, I wish to thank Allan Wille for his continuous support.

## Table of Contents

|                       |      |
|-----------------------|------|
| Abstract.....         | ii   |
| Acknowledgements..... | iii  |
| List of Tables.....   | vi   |
| List of Figures.....  | vii  |
| Abbreviations.....    | viii |

### Chapter I: Introduction

|   |    |
|---|----|
| Lipoproteins and Atherosclerosis.....                               | 1  |
| Lipid Transfer Proteins.....  | 4  |
| CETP in Lipid Metabolism.....                                       | 6  |
| PLTP in Lipid Metabolism.....                                       | 10 |
| The Lipid Transfer / Lipopolysaccharide Binding Protein Family..... | 14 |
| Structure / Function Aspects of CETP.....                           | 19 |
| Structure / Function Aspects of PLTP.....                           | 23 |
| The Carboxy-termini of CETP and PLTP.....                           | 26 |
| Rationale and Objectives.....                                       | 29 |

### Chapter II: Materials and Methods

|   |    |
|---|----|
| Molecular Biology.....  | 33 |
| Expression and Relative Quantification of Immunoreactive Protein..... | 44 |
| Lipid transfer Activities of Wildtype and Chimeric Proteins.....      | 48 |
| Data Analysis and Statistics.....                                     | 51 |

|  |    |
|--|----|
| Antibody Production.....   | 52 |
| <br>   |    |
| <b>Chapter III: Results</b>  |    |
| Expression of Proteins in COS-7 Cells.....                                       | 56 |
| Relative Quantification of Immunoreactive Protein.....                           | 58 |
| Lipid Transfer Activities of Wildtype and Chimeric Proteins.....                 | 59 |
| Antibody Production.....   | 64 |
| <br>   |    |
| <b>Chapter IV: Discussion</b>  |    |
| Design and Expression of Chimeric Proteins.....                                  | 69 |
| Method Development and Validation.....   | 71 |
| Lipid Transfer Activities of Chimeric Proteins, and Structural Implications..... | 74 |
| Anti-PLTP Antibodies.....  | 77 |
| Ongoing and Future Work.....   | 79 |
| Summary.....   | 84 |
| <br>   |    |
| References.....  | 85 |
| Statement of Contributions of Collaborators.....                                 | 97 |
| Curriculum Vitae.....  | 98 |

## List of Tables

|  |    |
|--|----|
| Table 1. Properties of plasma lipoproteins.....                            | 2  |
| Table 2. The sequences of oligonucleotides used for molecular biology..... | 35 |

## List of Figures

|   |    |
|---|----|
| Figure 1. The roles of CETP in lipid metabolism.....                                  | 7  |
| Figure 2. Reverse Cholesterol Transport.....  | 8  |
| Figure 3. The roles of PLTP in lipid metabolism.....                                  | 12 |
| Figure 4. Amino acid sequence alignment of human BPI, LBP, CETP, and PLTP.....        | 15 |
| Figure 5. The crystal structure of human BPI and two bound phospholipids.....         | 18 |
| Figure 6. Models of human CETP and PLTP tertiary structures.....                      | 20 |
| Figure 7. The ‘tilted peptide’ model of the CETP C-terminal helix.....                | 28 |
| Figure 8. Schematic representation of PLTP, CETP, and chimeric proteins.....          | 31 |
| Figure 9. Cloning of PLTP/CETP tail chimeras.....                                     | 39 |
| Figure 10. Cloning of CETP/PLTP tail chimeras.....                                    | 41 |
| Figure 11. Cloning of binding pocket chimeras by ‘monster chimera’ strategy.....      | 43 |
| Figure 12. Epitopes of monoclonal antibodies.....                                     | 46 |
| Figure 13. Expression of PLTP, CETP, and chimeric proteins in COS-7 cells.....        | 57 |
| Figure 14. Relative Quantitation of Immunoreactive Protein by Slot Blot.....          | 60 |
| Figure 15. Phospholipid transfer activity of PLTP, CETP, and chimeric proteins.....   | 61 |
| Figure 16. Cholesteryl ester transfer activity of CETP, PLTP, and chimeric proteins.. | 63 |
| Figure 17. Triglyceride transfer activity of CETP, PLTP, and chimeric proteins.....   | 65 |
| Figure 18. Screening of mouse sera for anti-human PLTP antibodies.....                | 68 |
| Figure 19. Structural models of two binding pocket chimeras of CETP and PLTP.....     | 82 |

## Abbreviations

|             |  |
|-------------|--|
| ABC         | ATP-binding cassette                             |
| apo         | apolipoprotein                                   |
| ATCC        | American type culture collection                 |
| BSA         | bovine serum albumin                             |
| BPI         | Bactericidal / Permeability Increasing Protein   |
| mAb         | monoclonal antibodies                            |
| CAD         | coronary artery disease                          |
| CE          | esterified cholesterol                           |
| CETP        | cholesteryl ester transfer protein               |
| CHD         | coronary heart disease                           |
| CHO cells   | chinese hamster ovary cells                      |
| CM          | Chylomicrons                                     |
| CMV         | cytomegalovirus                                  |
| COS-7 cells | monkey kidney cells                              |
| ELISA       | Enzyme-linked Immunosorbent Assay                |
| GM-CSF      | granulocyte-macrophage colony stimulating factor |
| HDL         | high density lipoprotein                         |
| HL          | hepatic lipase                                   |
| HUVE        | human umbilical vein endothelial                 |
| IDL         | intermediate density lipoprotein                 |
| kb          | kilobasepair                                     |

|       |                                       |
|-------|---------------------------------------|
| kDa   | kiloDalton                            |
| KO    | knockout                              |
| LCAT  | lecithin-cholesterol-acyl transferase |
| LDL   | low density lipoprotein               |
| LPS   | lipopolysaccharide                    |
| LPL   | lipoprotein lipase                    |
| LBP   | lipopolysaccharide binding protein    |
| PBS   | phosphate-buffered saline             |
| PC    | phosphatidylcholine                   |
| PCR   | polymerase chain reaction             |
| PL    | phospholipid                          |
| PLTP  | phospholipid transfer protein         |
| SR-B1 | scavenger receptor B1                 |
| TBS   | tris-buffered saline                  |
| Tg    | transgenic                            |
| TG    | triacylglycerol, triglyceride         |
| TrL   | triglyceride-rich lipoproteins        |
| TSE   | tris-saline-EDTA                      |
| VLDL  | very low density lipoprotein          |

## Chapter I: Introduction

### Lipoproteins and Atherosclerosis

Cholesterol and other lipids are required by tissues throughout the body for energy, membrane synthesis, and steroidogenesis. However, in order for hydrophobic lipids to be transported through the circulatory system, they must be shielded from the aqueous environment. This is achieved by the formation of lipoprotein particles, large complexes containing both lipid and protein. The predominant lipoprotein structure is a spherical particle with a core of neutral lipids, triacylglycerol (TG) and esterified cholesterol (CE), surrounded by a monolayer of amphipathic lipids, phospholipid and cholesterol, and stabilized by specific apolipoproteins. Plasma lipoprotein particles do not remain static; rather their size and composition are highly dynamic, due to continual remodeling by enzymes including lipid transfer proteins. Lipoprotein metabolism must be tightly regulated in order to maintain a healthy lipid balance, and avoid the development of cardiovascular and metabolic diseases. (Gotto et al. 1986)

Lipoproteins can be classified according to several criteria, including size, electrophoretic mobility, apolipoprotein and lipid composition, and buoyant density; however, the boundaries between classes are not rigid, and hence, even within each class, the populations are highly heterogeneous (Table 1). Chylomicrons (CM), large, TG-rich particles, are produced in the gut in a postprandial state, and are rapidly metabolized to generate remnants which are cleared from the circulation by the liver. Very low density lipoprotein (VLDL) particles are also large and TG-rich, and are secreted by the liver. VLDL are hydrolysed by lipoprotein lipase (LPL), giving rise to smaller and more dense

**Table 1. Properties of Plasma lipoproteins.**

Physical properties of human plasma lipoprotein classes. CM are the largest and least dense of the lipoproteins, as they have the highest ratio of lipid to protein. HDL are small and dense, and have a lower ratio of lipid to protein. Adapted from Gotto et al. (1986).

| <b>Class</b>           | <b>Density<br/>(g/ml)</b> | <b>Electrophoretic<br/>mobility</b> | <b>Diameter<br/>(nm)</b> | <b>Molecular<br/>weight<br/>(x10<sup>6</sup>Da)</b> |
|------------------------|---------------------------|-------------------------------------|--------------------------|---|
| <b>CM</b>              | 0.93                      | Remains at<br>origin                | 75-1200                  | 50-1000   |
| <b>VLDL</b>            | 0.93-1.006                | Pre-β                               | 30-80                    | 10-80   |
| <b>IDL</b>             | 1.006-1.019               | Slow pre-β                          | 25-35                    | 5-10  |
| <b>LDL</b>             | 1.019-1.063               | β                                   | 18-25                    | 2.3   |
| <b>HDL<sub>2</sub></b> | 1.063-1.125               | α                                   | 9-12                     | 0.36  |
| <b>HDL<sub>3</sub></b> | 1.125-1.21                | α                                   | 5-9                      | 0.175   |

intermediate density lipoprotein (IDL) particles. The IDL can be further hydrolysed by LPL and hepatic lipase (HL) to produce low density lipoprotein (LDL), the major transporter of cholesterol in human plasma. LDL particles have a core mainly of CE and can deliver cholesterol to cells via the cell-surface LDL receptor. Numerous studies have demonstrated a correlation between high plasma LDL-cholesterol levels and increased risk of atherosclerosis (reviewed in Frolich et al. 2001). Atherosclerosis begins with the development of a fatty lesion, which forms when LDL in the arterial wall becomes oxidized and is engulfed by macrophages to form foam cells (Parthasarathy et al. 1992; Ross 1999).

In contrast, an elevated plasma level of high density lipoprotein (HDL) - cholesterol is negatively correlated with premature coronary heart disease (CHD), a major cause of death worldwide (reviewed in Kwiterovich 1998). The exact mechanism for the protective effect of HDL is unclear, but is likely due in part to the involvement of HDL in the redistribution of cholesterol from peripheral tissues to the liver for excretion in bile or reincorporation into lipoproteins. This process is known as 'reverse cholesterol transport' (reviewed in Bruce et al. 1998a). In the initial step of this pathway, a transporter such as the ATP-binding cassette protein, ABC-A1, on the surface of cells such as macrophages and fibroblasts, promotes efflux of cellular cholesterol onto HDL. A subfraction of the HDL population, which are lipid-poor, disc-shaped particles with a pre- $\beta$  electrophoretic mobility (pre- $\beta$ -HDL), are particularly efficient acceptors of cellular cholesterol (Barter and Rye 1996).

## Lipid Transfer Proteins

In the late 1970s, a protein that could catalyse the exchange of cholesteryl esters among lipoproteins was isolated from human lipoprotein deficient plasma (Patnaik et al. 1978). This factor was also shown to be capable of transferring triglyceride between lipoproteins (Morton and Zilversmit 1982). LTP-1, as it was initially called, could exchange phosphatidylcholine (PC) between LDL and HDL, but could not facilitate mass transfer of PC from phospholipid vesicles to HDL (Tall et al. 1983), suggesting the presence of at least one other plasma lipid transfer protein. In fact, a second plasma factor, called LTP-II, was later separated from LTP-I and characterized (Albers et al. 1984; Tall et al. 1983; Tollefson et al. 1988). In contrast to LTP-I, LTP-II had no neutral lipid transfer activity but could facilitate net mass transfer of phospholipid (PL) from VLDL to HDL (Tollefson et al. 1988). LTP-II was also found to be identical to a plasma factor which could convert HDL<sub>3</sub> into smaller and larger particles *in vitro* (Rye and Barter 1986). LTP-I and -II are now referred to as cholesteryl ester transfer protein (CETP), and phospholipid transfer protein (PLTP), respectively.

The cDNA for human CETP was cloned in 1987 from a human liver cDNA library. It was found to encode a 17 amino acid signal peptide, followed by a 476 residue mature protein (Drayna et al. 1987). In humans, CETP mRNA is most highly expressed in liver, spleen and adipose tissue, and to a lesser degree, in small intestine, adrenal, kidney, and heart (Drayna et al. 1987; Jiang et al. 1991). CETP mRNA has been found in several species, including human, monkey, hamster, and rabbit, with 80-95% homology between species (Nagashima et al. 1988; Drayna et al. 1991; Jiang et al. 1991; Pape et al. 1991). To date, plasma CETP activity has been detected in some species

including human, rabbit, hamster and chicken, but not in other species such as mouse, rat, and pig. (Ha and Barter 1982; Guyard-Dangremont et al. 1998) Human plasma of normolipidemic subjects contains CETP at about 2 µg/ml (Marcel et al. 1990).

The complete cDNA for human PLTP was cloned from a human umbilical vein endothelial (HUVE) cell cDNA library in 1994 (Day et al. 1994). Within the 1750 base pair cDNA, a 1518 nucleotide open reading frame encodes a 17 amino acid hydrophobic signal sequence followed by a 476 amino acid mature protein. The human, mouse, rabbit, and pig PLTP genes share greater than 80% homology (Pussinen et al. 1997; Jiang and Bruce 1995a; Albers et al. 1995; Gander et al. 2002). PLTP mRNA is ubiquitously expressed in human tissues, with the highest expression in the placenta, pancreas, and lung, followed by kidney, heart, liver, skeletal muscle, and brain (Day et al. 1994). Plasma PLTP activity has been found in all species tested to date, including mouse, goat, sheep, and chicken (Guyard-Dangremont et al. 1998). Recent reports indicate that there may be two distinct forms of PLTP in human plasma: a low activity form in a high molecular weight complex containing apoAI, and a high activity form in a low molecular weight, apoE-containing complex (Oka et al. 2000a; Karkkainen et al. 2002). There are variable reports of plasma PLTP concentration, and of the correlation between PLTP mass and activity in plasma (Murdoch et al. 2002; Desrumaux et al. 1999; Oka et al. 2000b; Huuskonen et al. 2000a). This controversy may be due to differences in anti-PLTP antibodies, or to the presence of inactive but immunoreactive PLTP in plasma (Oka et al. 2000a).

## **CETP In Lipid Metabolism**

CETP is responsible for all of the neutral lipid transfer activity in human plasma (Tall et al.1983; Hesler et al. 1988). It mediates an equimolar exchange of neutral lipids between CE-rich lipoproteins such as HDL, and TG-rich lipoproteins such as VLDL, resulting in a net exchange of CE into VLDL and TG into HDL (Morton and Zilversmit 1983; Yen et al.1989). Similarly, TG from VLDL can be exchanged with CE from LDL. TG transfer is required for net CE transfer, suggesting that CETP operates via a hetero-exchange mechanism (Ko et al. 1995). In fact, most evidence indicates that CETP probably acts as a shuttle, carrying lipids back and forth between lipoproteins (Swenson et al. 1988; Swenson et al. 1989; Connolly et al 1996). CETP may also facilitate a selective uptake process in which CE is transported into the cell without HDL particle degradation. Cell-surface CETP on adipocytes appear to mediate this process, although it is unclear what the exact mechanism is (Benoist et al.1997). (Figure 1).

CETP is thought to have multiple roles in the reverse cholesterol transport pathway (Figure 2). First, cholesterol that has been effluxed from cells to discoidal, lipid-poor HDL is esterified by the enzyme lethicin-cholesterol-acyl transferase (LCAT), and the HDL particle assumes a spherical conformation with  $\alpha$ -electrophoretic mobility. The LCAT-mediated esterification of cholesterol is promoted by CETP (Oliveira et al. 1997). Second, the CE is transferred, via CETP, from HDL to apoB-containing lipoproteins VLDL and CM remnants, allowing delivery of cholesterol to the liver via the LDL receptor. And third, the neutral lipid exchange mediated by CETP causes the HDL particle to become more TG-enriched. The products of hydrolysis of the TG-rich HDL by HL, called “remnant HDL” can be taken up by the liver or can interact with scavenger

**Figure 1. The Roles of CETP in lipid metabolism**

**A)** CETP mediates a reciprocal exchange of neutral lipids between lipoproteins. The result is a net mass transfer of TG into HDL or LDL from VLDL, and of CE into VLDL from HDL or LDL.

**B)** Cell surface CETP on adipocytes may also mediate selective uptake of CE from HDL, without whole particle uptake.

**A**

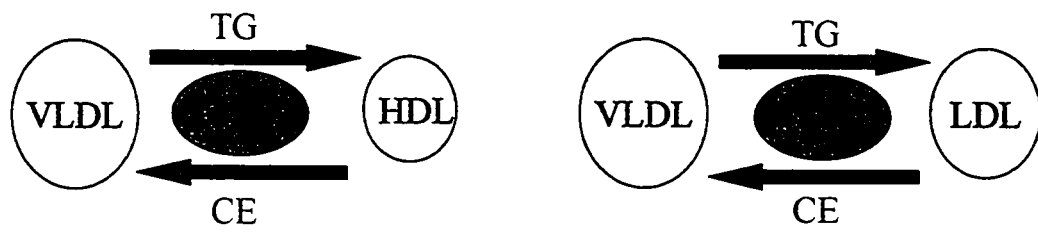

**B**

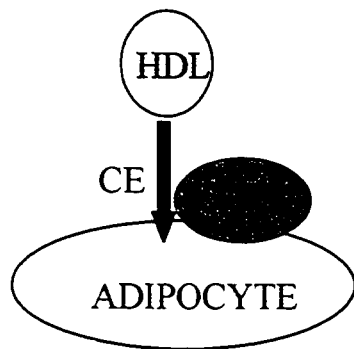

## **Figure 2. Reverse Cholesterol Transport.**

The roles of CETP and PLTP are highlighted.

Free cholesterol and phospholipid are effluxed from peripheral cells such as macrophages via cell surface ABC-A1 **(A)**. Pre $\beta$ -HDL is an efficient acceptor of effluxed cholesterol, and is formed primarily through the actions of PLTP, by transfer of excess surface lipids generated during hydrolysis of triglyceride-rich lipoproteins (CM or VLDL) onto lipid poor apoAI, and through HDL remodeling **(B)**. Esterification of the cholesterol by LCAT, a reaction promoted by CETP, results in a change of conformation of the HDL, from discoidal to spherical **(C)**. Esterified cholesterol can then be transferred to apoB-containing lipoproteins via CETP, for delivery to the liver through the LDLreceptor **(D)**. Large, TG-rich HDL particles are formed as a result of CETP activity, and are hydrolysed by HL, resulting in remnant HDL particles that can be taken up by the liver, or can interact with SR-B1, leading to selective CE uptake **(E)**.

(adapted from VanTol 2002)

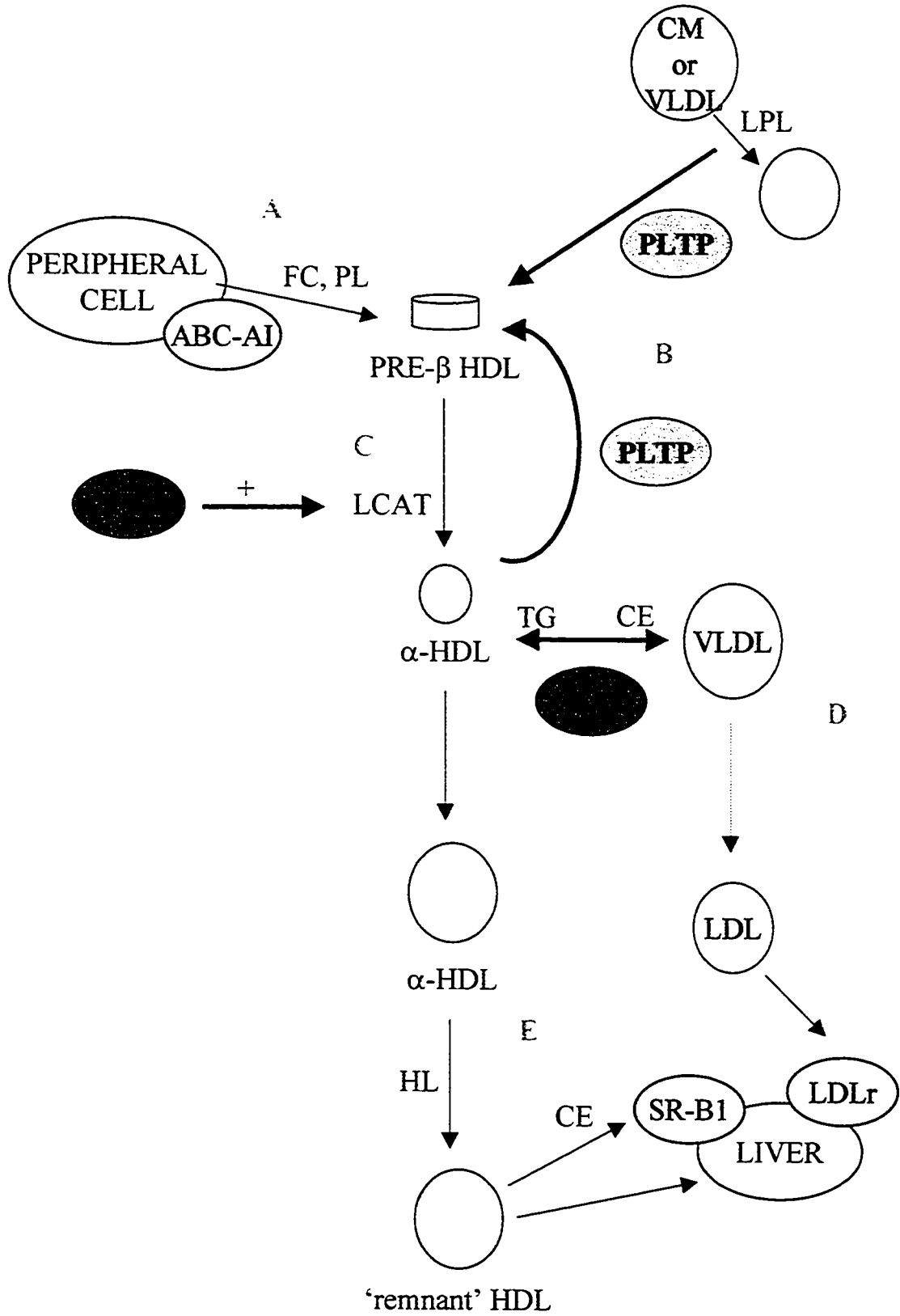

receptor B1 (SR-B1), leading to selective CE uptake (Acton et al. 1996; Collet et al. 1999). CETP on the surface of hepatocytes also appears to mediate selective uptake from HDL (X. Zha, personal communication).

In the general population of normolipidemic people, no strong relationship between CETP and HDL-cholesterol levels has been determined (Marcel et al. 1990). However, several genetic mutations resulting in CETP deficiency are prevalent in people of Japanese descent, and are thought to account for about 10% of the variance in HDL levels in that population (Inazu et al. 1994). Two mutations in particular which have high allele frequencies are a mutation in intron 14 causing defective mRNA splicing (2% allele frequency), and a missense Asp442Gly substitution resulting in poorly secreted CETP with reduced CE transfer activity (7% allele frequency) (Brown et al. 1989; Takahashi et al. 1993). CETP-deficient subjects have an increased level of plasma HDL-cholesterol, particularly in the form of large CE-rich particles. Delayed catabolism of the apoAI associated with these large particles also results in an elevated level of plasma apoAI (Yamashita et al. 1990; Ikewaki et al. 1993). Due to the absence of neutral lipid transfer, subjects with complete CETP deficiency have an increased TG to CE ratio in VLDL and IDL, and their LDL tends to be small and TG-rich. These LDL are potentially atherogenic because of a low affinity for LDL receptor (Bisgair et al. 1991; Sakai et al. 1995). In several studies, subjects with CETP deficiency had a higher incidence of coronary artery disease (CAD) than those without CETP mutations, excluding a subgroup of subjects with the highest level of HDL who appeared to be protected, regardless of their CETP genotype (Zhong et al. 1996; Moriyama et al. 1998). However, in another

study, CETP deficiency appeared to be a risk factor for CAD, despite elevated plasma HDL levels (Hirano et al. 1997).

Neutral lipid transfer activity is negligible in mice, and in these animals, most of the plasma cholesterol is found in the HDL fraction. Mice transgenic for human CETP have a decreased level of HDL-cholesterol and increased VLDL- and LDL-cholesterol (Agellon et al. 1991; Jiang et al. 1993). These changes in lipid profile are even more pronounced in mice that express both human CETP and human apoAI, likely due to preferential interaction of CETP with species-specific HDL particles (Hayek et al. 1992). On a high-fat diet, these mice only had a slight increase in aortic fatty streaks (Hayak et al. 1995), but in another study in which mice were transgenic for simian CETP, feeding a high-fat diet resulted in severe atherosclerosis (Marotti et al. 1993).

On one hand, it would seem that CETP could promote atherosclerosis by decreasing plasma HDL. On the other hand, the role CETP plays in the reverse cholesterol transport pathway would make it an anti-atherogenic agent. Adding to the confusion is the fact that various animal models have provided conflicting evidence. It appears that the general environment in terms of genetics, diet, and metabolism determines the overall effect of CETP on atherosclerosis. And thus it remains unclear whether ultimately CETP is protective or proatherogenic.

### **PLTP In Lipid Metabolism**

Both PLTP and CETP can mediate the exchange of phospholipids (PL) among lipoproteins, and each protein is thought to contribute about half of the PL exchange activity in human plasma (Tall et al. 1983; Hesler et al. 1998). However, only PLTP can

mediate net mass transfer of PL (Tall et al. 1983). As triglyceride-rich particles such as CM and VLDL undergo lipolysis, the lipoprotein core size is reduced, leaving an excess of surface components such as phospholipid, cholesterol, and apolipoproteins. PLTP enhances the transfer of excess PL from VLDL to nascent HDL during lipolysis of these particles, a process which can be modeled *in vitro*, using radiolabelled PC vesicles. (Tall et al. 1985). PLTP can also transfer excess unesterified cholesterol onto the new HDL particles (Nishida and Nishida 1997) (Figure 3). So far, no intermediate of PLTP bound to ligand has been isolated, so it has been proposed that in contrast to CETP, PLTP may form a bridge between donor and acceptor particles, possibly lowering the energy barrier for lipid dissociation or association (Huuskonen, et al. 1996; Huuskonen et al. 2001; Lallanne and Ponsin 2000).

The importance of PLTP for HDL generation can be seen in several animal models. Plasma from PLTP knockout (PLTP KO) mice is unable to facilitate PL transfer in both *in vitro* and *in vivo* assays (Jiang et al 1999). These mice had significantly reduced levels of plasma HDL-PL, -cholesterol, and -apoA1. The decrease in HDL may be compounded by an increased rate of catabolism of the unstable HDL particles in these animals (Qin et al 2000). Additionally, when the PLTP KO mice are fed a high-fat diet, they have increased lipids in VLDL and LDL, indicating the accumulation of lipoprotein surface components in TG-rich particles. In order to address whether CETP activity could compensate for a lack of PLTP activity *in vivo*, PLTP KO mice were crossed with human CETP transgenic (CETP Tg) mice. The *in vitro* and *in vivo* PL transfer activity in the PLTP KO / CETP Tg mice were the same as the PLTP KO alone, suggesting that the primary mediator of plasma PL transfer activity is PLTP (Kawano et al. 2000). These

**Figure 3. The roles of PLTP in lipoprotein metabolism.**

**A)** As VLDL and chylomicrons undergo lipolysis by lipoprotein lipase, excess surface phospholipids are released. PLTP transfers these PL onto lipid-poor apoAI particles to form discoidal pre $\beta$ -HDL.

**B)** PLTP also mediates an HDL conversion process, generating discoidal, lipid poor pre $\beta$ -HDL and larger HDL<sub>2</sub> particles from small, spherical HDL<sub>3</sub> particles.

(adapted from Huuskonen et al. 2000b)

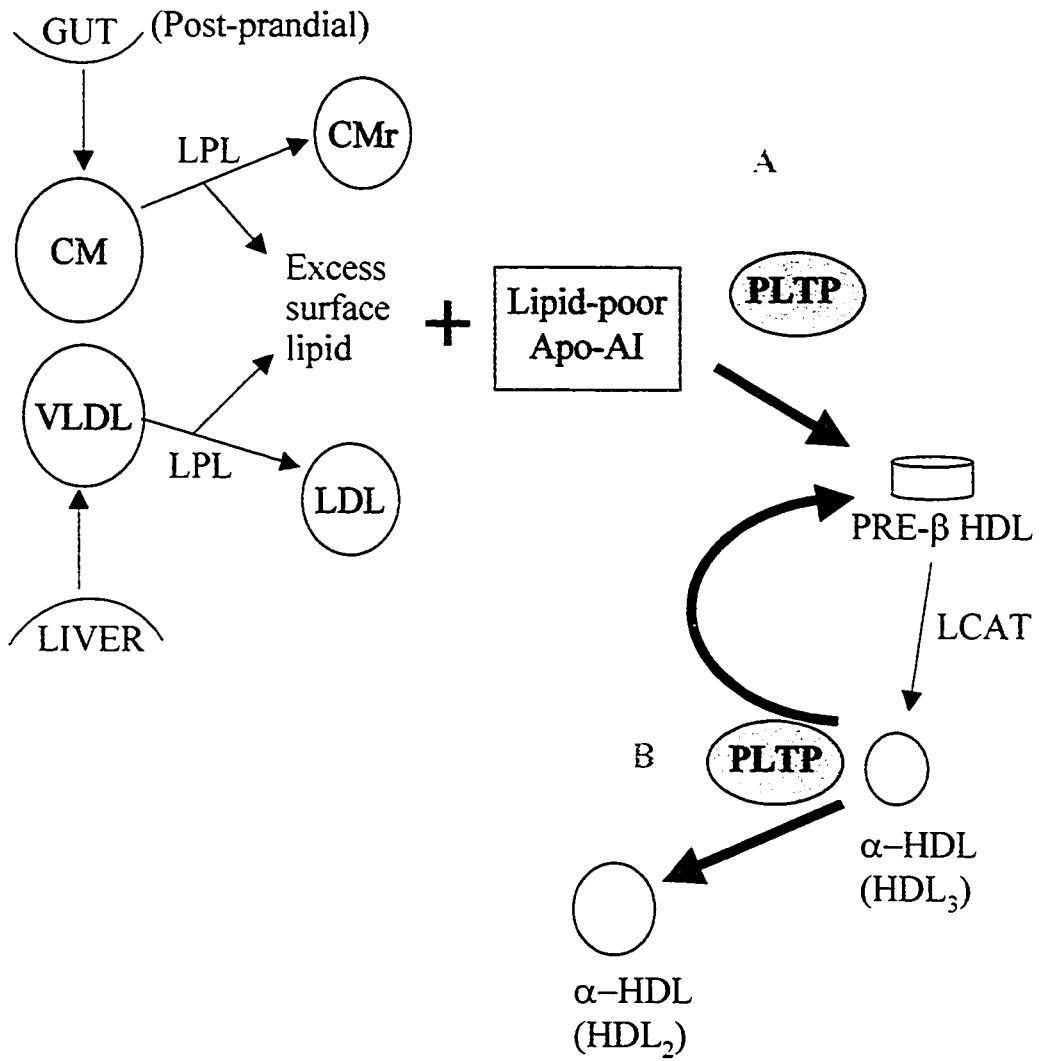

studies emphasize the importance of PLTP activity *in vivo* for maintenance of plasma HDL levels.

In mice expressing high levels of human PLTP, introduced by either adenovirus or a transgene, total HDL levels are significantly reduced (Föger et al 1997; Ehnholm et al. 1998; van Haperen et al. 2000). However, generation of the pre- $\beta$  subclass of HDL particles is increased in these animals. In contrast to the high PLTP expressors, mice transgenic for both human PLTP and human apoAI had only slightly increased PLTP expression, and the lipid profiles actually showed an increase in plasma HDL-lipid and apoAI (Jiang et al. 1996). Nonetheless, plasma from these mice also possesses an increased ability to generate pre- $\beta$  HDL. This highlights a second major function of PLTP, known as 'HDL-conversion' or 'HDL-remodeling'. *In vitro*, when purified plasma PLTP is incubated with HDL<sub>3</sub>, larger HDL<sub>2a</sub> particles are generated, and lipid-poor apoAI is released. (Jauhiainen et al. 1993; Tu et al. 1993) (Figure 3). Correspondingly, *in vivo*, increased PLTP activity results in the formation of larger HDL particles which can carry lipid to the liver, and smaller, lipid poor pre- $\beta$  HDL particles. PLTP is also capable of proteolytic cleavage of apoAI which could contribute to enhanced HDL clearance in mice expressing higher levels of PLTP (Jauhiainen et al. 1999).

Several mechanisms involving particle fusion have been proposed for PLTP-mediated HDL conversion. One model suggests that lipid-poor apoAI is released from the HDL surface due to an increased surface pressure caused either by penetration of the lipoprotein surface by PLTP, or by an increase in the amount of surface lipid resulting from net PL transfer (Lusa et al. 1996). The HDL particle becomes unstable as its core is partially exposed by the loss of apoAI, and two unstable particles fuse to form a larger,

thermodynamically stable particle. A second model of PLTP-mediated HDL conversion proposes that PLTP initially catalyses the fusion of two HDL particles to form an intermediate that is unstable and subject to further remodeling (Settasatian et al. 2001). The intermediate fusion product can either rearrange into 3 smaller particles, or, at a slower rate, form a single, more stable, larger HDL particle, accompanied by the release of lipid-poor apoAI. PL transfer activity appears to be required for the HDL remodeling activity of PLTP, as inhibitors or mutations in PLTP that eliminate PL transfer activity also eliminate HDL conversion (Huuskonen et al. 2000c).

The generation and remodeling of HDL particles by PLTP is crucial for reverse cholesterol transport. Lipid poor pre- $\beta$  HDL is an efficient acceptor of cellular cholesterol, and larger HDL particles are ligands for SR-B1-mediated CE uptake in the liver (Figure 2). In fact, plasma from human PLTP Tg mice was able to prevent the accumulation of cholesterol in macrophages, demonstrating that PLTP directly promotes cholesterol efflux (van Haperen et al. 2000). Thus PLTP could be considered to be anti-atherogenic. Recently, however, PLTP deficiency in two mouse models with genetic susceptibility to atherosclerosis was shown to decrease the secretion of apoB-containing lipoproteins and slowed progression of the disease (Jiang et al. 2001). Clearly the role of PLTP in overall lipoprotein metabolism is complex and still not well understood.

### **The Lipid Transfer/ Lipopolysaccharide Binding Protein Family**

The lipid transfer / lipopolysaccharide (LPS) binding gene family includes CETP, PLTP, Bactericidal / Permeability-Increasing Protein (BPI) and LPS-binding protein (LBP) (Day et al. 1994) (Figure 4). All four family members are hydrophobic proteins

**Figure 4. Amino acid sequence alignments of BPI, LBP, PLTP, and CETP.**

All four human sequences are shown in the top panel. The alignment was done by CLUSTAL32 using 11 known mammalian sequences. Completely conserved residues are indicated with an asterisk, highly conserved residues with a dot. The secondary structure of BPI is shown:  $\alpha$ -helices are represented by cylinders and  $\beta$ -strands by arrows. The horizontal dashed line indicates the linker region between the amino and carboxyl terminal domains.

From: Beamer et al.1997. *Science* **276**: p.1863 (Reproduced with permission)

The same alignment was used in the bottom panel, but only the human PLTP and CETP sequences are shown. Hydrophobic residues are shown in red, positively charged residues in blue, and negatively charged residues in green. Identical amino acids are indicated with an asterisk.

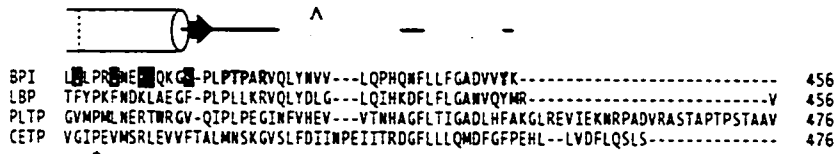
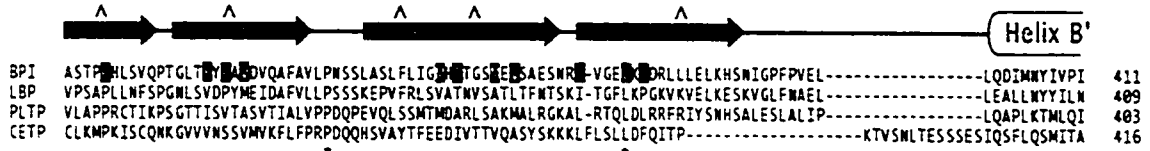
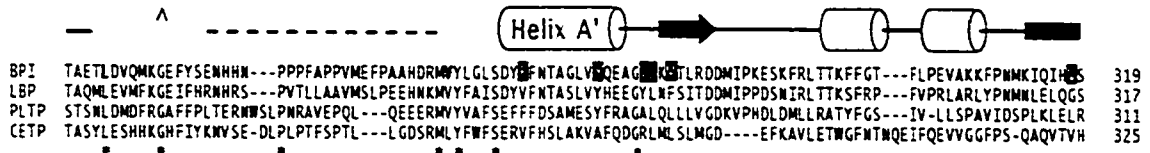
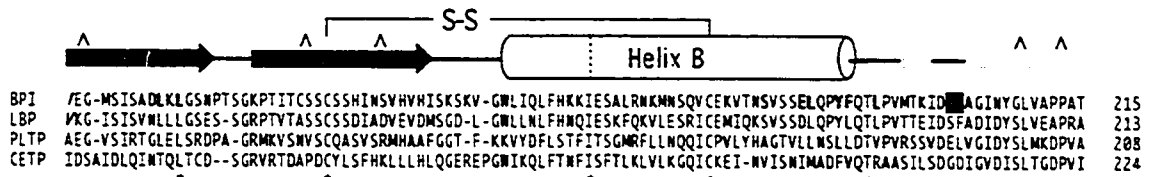
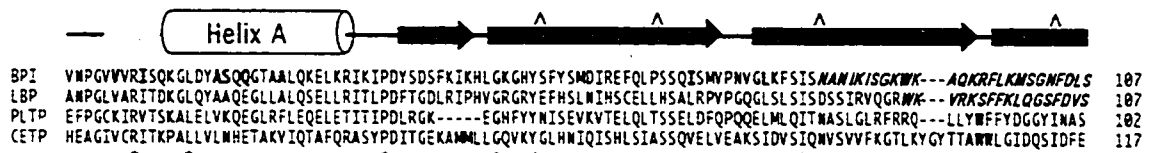

PLTP -----EPGCKIRVRSKALELVKQEGRLFLQELETITIPDLRGK----EGHFYNYISEVKYTELQLTSSSELDFO 66  
 CETP CSKGTSHAGIVCRITKPALVLVNHEATKYQTAFAQRASYPDITGEKAMMLGQVYKGLHNIQISHLSIASSQVLE 77

PLTP PQQELMQLQITNASLGLRFRRO---LLYFFYDGGYINASAG-VSIRTGLELRDPA-GRMKVSNVSCQASVSRMH 137  
 CETP LAKSINVSIGNVSNVFKGTLKYGYTTAWLIGDQSIDVSIQNVSVVFKGTLKYGYTTAWLIGDQINTQLTCD--SGRVRTDAPDCYLSFHKLL 151

PLTP AAFGGT-F-KKVDLSTFITSGRMFLNQIICPVLYHAGTVLLNSLLDTPVRSVDELVGDYSLMKDPVASTSN 212  
 CETP LHLQGEREPGNIKQLFTNFI SFTLKLVLKQKICKET-NVISNIMADFVQTRAASILSDGIGVDSLTGDPVI 227

PLTP LDMDFRGAFFPLTERNWSLPNRAVEPQL---QEERMVYVAFSEFFFDAMESYFRAGALQLLVGDKVPHOLDMLLRAT 289  
 CETP LSHHKGFYKMYSE-DLPLPTFSPTL---LGD SRMLYFWFSE RVFHS LAKVAFOGRMLSLMGD----EFKAVLETW 299

PLTP YFGS---IV-LLSPAVIDSPLKLELRVLAPPRCTIKPSGTTISVTASVTIALVPPDQPEVQLSSMTMDARLSAKMAL 362  
 CETP GENTNQEIFQEVVGGFPS-QAQVTVHCLKMPKISCONKGVVNSVMVKFLFRPDQHSVATTFEEDIVTTVQASY 375

PLTP RGAAL-RTQLDLRRFRYISNHSALSLALIP-----LQAPLKTMLQIGVMPMLNERTWRGV-QIPLPEG 424  
 CETP SKKGLFLSLLDFOITP-----KTVSNLTESSESISQSFQSMITAVGIPVMSRLEVFTALMNSK 437

PLTP INFVHEV---VTNHAGFLTIGADLHFAGKLEREVIEKNRPADVRASTAPTSTAAY 476  
 CETP VSLFDIINPEIITRDGFLLLQMDFGFPEHL--LVDFLQSLSS----- 476

capable of binding phospholipid and LPS. In addition to these common ligands, a range of other hydrophobic and amphipathic compounds can be bound by individual family members. For instance, CETP can bind the neutral lipids CE and TG, as well as retinyl esters, cholesterol, and 25-hydroxycholesterol (Bruce et al. 1998b), and PLTP can bind  $\alpha$ -tocopherol (vitamin E) and unesterified cholesterol in addition to various phospholipids (Kostner et al. 1995; Nishida and Nishida 1997; Rao et al. 1997). BPI and LBP assist in the host response to Gram-negative bacterial infection by binding to endotoxins (LPS) on the bacterial cell surface, while CETP and PLTP modulate lipid metabolism by exchanging lipids among lipoproteins and cells. BPI is a membrane-bound cellular protein, whereas LBP, CETP, and PLTP are primarily found as HDL-associated plasma proteins. The human PLTP, BPI, and LBP genes are on chromosome 20, and the CETP gene has been mapped to chromosome 16 (Whitmore et al. 1995). These four genes are probably descendants of a common ancestor gene, as they share similar intron/exon boundaries (Tu et al 1995).

The x-ray crystal structures of PLTP and CETP have yet to be determined; however a great deal of information can be obtained by analysis of the 3-D structure of BPI. In 1997, the human BPI structure was determined by x-ray crystallography to a resolution of 2.4 Å, and was refined in 2000 to 1.7Å (Beamer et al 1997; Kleiger et al. 2000). Despite its hydrophobicity, BPI was found to be an elongated molecule with its length nearly four times its width, and curved into a 'boomerang' shape. Although the amino acid sequences of the amino- and carboxyl- terminal halves of the protein are only 15% identical, the molecule possesses a two-fold axis of pseudosymmetry and folds into two very similar domains. Opening onto the concave face of each domain is an apolar

ligand-binding pocket bounded by two  $\alpha$ -helices and backed by a 5-stranded  $\beta$ -sheet. The two domains are connected by a central  $\beta$ -sheet. The crystal structure of BPI was solved with a phospholipid molecule bound in each pocket; the acyl chains are buried within the protein, and the polar head groups are exposed to solvent. (Figure 5).

A significant degree of amino acid homology is shared between BPI and the other three family members: human CETP is about 20% identical to PLTP, and about 25% identical to LBP and BPI; human PLTP is 24% identical to LBP and 26% to BPI (Day et al. 1994; Jiang et al 1995b). In particular, residues important for structure and function are conserved throughout the family, such as two highly conserved cysteine residues that form a single disulfide bond in each molecule. In BPI, Cys132 and Cys175 have been shown to be essential for function (Horwitz et al 1996). Similarly, in PLTP, Cys146 and Cys185 are directly required for proper protein folding and secretion (Huuskonen et al. 1999). The corresponding amino acids in CETP are Cys143 and Cys184. (Bruce et al. 1998b). Conservation of residues among family members seems to be greatest in the central region of the BPI structure, where secondary structural elements form the overall protein fold around the two lipid-binding pockets. Residues localized to the tips of the boomerang shape are more variable, and were found to be important for functional differences between BPI and LBP (Beamer et al.1998). Considering the genetics, amino acid sequence similarity, and common ligands of the four family members, it seems likely that they would share elements of tertiary structure and possibly also some functional mechanisms.

**Figure 5. The crystal structure of human BPI and two bound phospholipids.**

BPI forms a 'boomerang' shaped molecule, with two very similar domains giving it pseudo-twofold symmetry. The amino-terminal domain is shown in green, and the carboxy-terminal in blue. Each domain has a hydrophobic pocket formed by two  $\alpha$ -helices and a 5-stranded  $\beta$ -sheet. The amino and carboxyl terminal domains are connected by a proline-rich linker, shown in yellow.

**A)** A view of the concave side of the molecule. A phosphatidylcholine molecule is bound in each of the two hydrophobic pockets, with the acyl chains inside the pocket and the polar head group facing solvent (shown in grey and red).

**B)** A view of the convex side of the molecule. The amino and carboxyl terminal domains each form a  $\beta$ -barrel, connected by a central  $\beta$ -sheet.

Images were produced using Rasmol (Sayle and Milner-White 1995). (PDB accession number 1bp1)

A



B

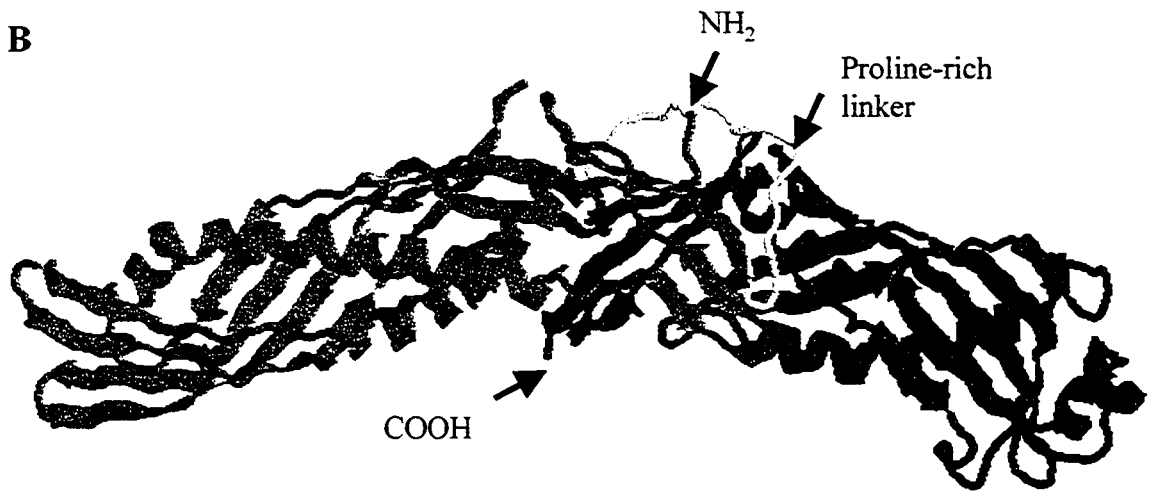

NH<sub>2</sub> TERMINAL  
β-BARREL

CENTRAL  
β-SHEET

COOH TERMINAL  
β-BARREL

## Structure / Function aspects of CETP

CETP has been shown to have a stable tertiary structure that is resistant to degradation by urea, and attempts to isolate an active fragment of CETP from bacteria have been unsuccessful, suggesting that it is the global structure of the protein that enables it to function (Hesler et al. 1989). It has been proposed that CETP adopts a tertiary structure resembling that of BPI, and based on an amino acid sequence alignment of human CETP and BPI, and the atomic coordinates of the BPI structure, a model of the 3D structure of CETP has been built (Figure 6A). This model is supported by biophysical measurements indicating that CETP has an elongated shape with proportions of  $\alpha$ -helices and  $\beta$ -sheets that are similar to those of BPI (Connolly et al. 1996).

Further evidence in support of a BPI-like structure of CETP comes from immunochemical analyses (Roy et al. 1996; Guyard-Dangremont et al. 1999). The epitopes of a panel of anti-CETP monoclonal antibodies (mAb) were mapped to the linear sequence of CETP by testing their reactivity to peptide fragments expressed in *E.coli*, and then pairs of antibodies were tested for competition for binding to native CETP. Antibodies that were far apart in the linear sequence could exhibit competition, and when the epitopes were examined in the proposed model of CETP, they were found to be in close proximity. It is interesting that most of the antibodies generated against CETP have epitopes on the convex side of the molecule, possibly an indication that the concave side of the molecule is not usually exposed to solvent. Despite epitopes far from the putative lipid binding pockets, several antibodies could inhibit CETP-mediated lipid transfer (TP12, TP18, and TP19). This would suggest that rather than directly blocking

**Figure 6. Models of human CETP and PLTP tertiary structures.**

**A) CETP.** The model of CETP residues 7 to 476 is based on the tertiary structure of human BPI, and a sequence alignment of CETP and BPI. CETP residues 7 to 464 are shown in grey, and are positioned according to the atomic coordinates of the corresponding residues of BPI. Residues 465 to 476 of CETP (red) extend past the carboxy-terminus of BPI, and have been added into the model in a hypothetical position. These amino acids are thought to form an amphipathic  $\alpha$ -helix, and energy minimization predictions have the helix lying across the entrance to the amino-terminal lipid-binding pocket.

The atomic coordinates for this model were obtained from Dr. L. Beamer (University of Missouri-Columbia), and the image was produced using Rasmol (Sayle and Milner-White 1995).

**B) PLTP.** The model of PLTP residues 1 to 448 is based on the tertiary structure of human BPI, and a sequence alignment of PLTP and BPI. Residues 448-476 of PLTP extend past the C-terminus of BPI and are therefore not included in the model.

The atomic coordinates for this model were obtained from Dr. V. Olkkonen (National Public Health Institute, Helsinki, Finland), and the image was produced using Rasmol (Sayle and Milner-White 1995).

A



B

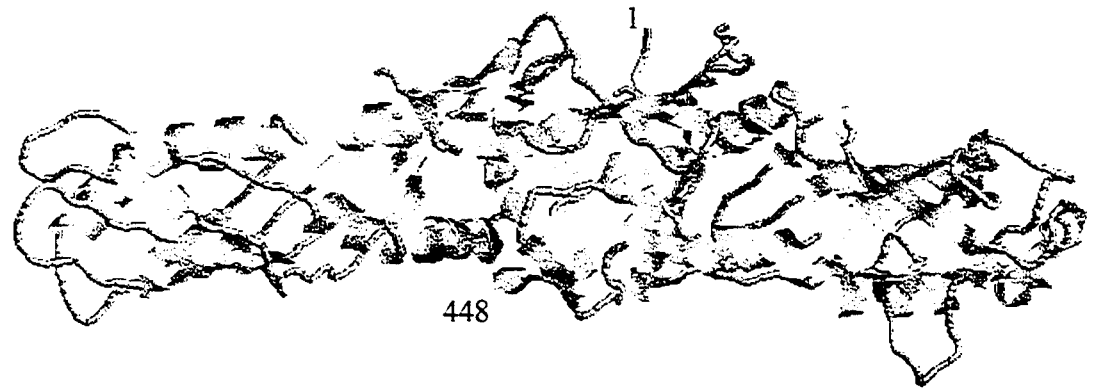

$\text{NH}_2$  TERMINAL  
 $\beta$ -BARREL

CENTRAL  
 $\beta$ -SHEET

$\text{COOH}$  TERMINAL  
 $\beta$ -BARREL

lipoprotein binding or access to the ligand pocket, inhibition is accomplished by an indirect mechanism such as by eliciting a conformational change.

There is some evidence that, like BPI, CETP has two distinct lipid binding pockets, although it is not known whether each pocket binds only specific lipids. Inhibitors exist that can selectively block either CE or TG transfer activity, and both activities can be simultaneously blocked by adding a TG and CE inhibitor together, suggesting that the 2 neutral lipids are not competing for the same binding site. (Melchior et al. 1995; Ko et al. 1994; Morton and Zilversmit 1982). However, as the TG molecule is significantly larger than CE, these findings could instead be the result of variable interactions of the inhibitors with CETP and the two ligands. On the other hand, TG and CE do compete for transfer (Ohnishi et al. 1994), which would suggest that the two lipids may bind in the same pocket. One model for CETP proposes that one binding pocket is specific for binding neutral lipids and the other for phospholipids (Wang et al. 1992). As several positively charged residues are predicted to be localized near the entrance to the C-terminal ligand-binding pocket, this pocket could be specialized for PL binding (Bruce et al. 1998b). The N-terminal pocket, which does not contain charged residues, could be specific for neutral lipids. CE transfer is inhibited by modification of Cys13, which is predicted to be in the N-terminal binding pocket, evidence that implicates this pocket in CE transfer. Unfortunately, however, the effect of this modification on TG or PL transfer activity was not studied. (Hope et al. 2000). Similarly, there appears to be a free cysteine (Cys333) in the C-terminal binding pocket, and modifications of this residue may provide steric hindrance to CE transfer (Epps and Vosters 2002).

The calculated molecular weight of CETP is 53 kDa yet the observed molecular weight on SDS-PAGE ranges from 66 to 74 kDa. This discrepancy is due to N-linked glycosylation at four sites: Asn88, Asn240, Asn341, and Asn396, and the broad range of sizes observed results from variable glycosylation at Asn341 (Stevenson et al. 1993). The proposed model of CETP indicates that the asparagine residues 88, 240, and 396 are all exposed to solvent, whereas Asn341 is partially buried in the protein structure, and is therefore less accessible for glycosylation. The model also suggests that all of the glycosylation sites are localized to the convex side of the protein, restricting interactions with lipoproteins to the concave side, a reasonable proposal as it seems the lipid binding pockets open onto the concave surface (Bruce et al. 1998b).

The interaction of CETP with lipoproteins results from a combination of hydrophobic and electrostatic interactions. The affinity of CETP for the lipoprotein surface increases as the surface charge becomes more negative, and this is accompanied by a faster rate of lipid transfer (Nishida et al. 1993; Desrumaux et al. 1998). Two positively charged residues are conserved among the lipid transfer/LPS binding protein family; in CETP these correspond to Lys233 and Arg259. The single amino acid mutants K233A and R259D both have reduced CE transfer activity, and in the case of K233A, defective binding to HDL (Jiang et al. 1995b). However, according to the model of CETP structure, both of these residues seem to be located on the convex side of the protein, and therefore it is unlikely that either residue participates directly in HDL binding. (Bruce et al. 1998b). It is still unclear exactly how these charged residues are involved in CETP-lipoprotein interactions and CETP-mediated neutral lipid transfer.

Some other residues that are structurally important have been identified by point mutation. The mutants P446R, L456R, D460G and K377A all show decreased CETP secretion in cell culture, and inheritance of the D442G mutant allele of CETP found in some Japanese subjects results in decreased secretion of CETP (Wang et al. 1993; Jiang et al. 1995b; Takahasi et al. 1993). According to our model, none of these residues is located on the concave face or in the binding pockets, suggesting a role in overall protein folding. Residues 442, 446, and 456 may form part of the central  $\beta$ -sheet connecting the two lipid binding pockets, a region which is probably required for the overall protein fold (Bruce et al 1998b).

### **Structure / Function aspects of PLTP**

It has been proposed that PLTP also has a BPI-like protein structure, and so molecular models of the 3D structure of PLTP have been made, based on the crystal structure of BPI and amino acid sequence alignments (Huuskonen et al. 1999, Desrumaux et al. 2001) (Figure 6B). In contrast to CETP, a lack of a large panel of antibodies to PLTP means that other methods of examining protein structure must be used. To date, point mutagenesis has been the primary tool used to examine structure-function relationships of PLTP, and to identify residues involved in PLTP-lipoprotein interactions and PLTP-mediated phospholipid transfer.

In order to determine the roles of each of the two putative lipid binding pockets of PLTP, point mutations have been made to residues predicted to sit inside or at the entrance to the N-terminal and C-terminal lipid binding pockets<sup>1</sup> (Huuskonen et al. 1999).

---

<sup>1</sup> Throughout this document, PLTP residue numbering refers to the mature protein.

Each mutation was designed so it should not disrupt proper protein folding, and this was confirmed by efficient secretion in each case. Valine 17, predicted to sit inside the N-terminal binding pocket, was changed to a bulky tryptophan residue to exclude the fatty acyl chains of a ligand from the pocket. This mutation resulted in a significant decrease in PL transfer activity but only a modest reduction in HDL-binding, relative to wildtype PLTP. At the entrance to this same binding pocket, the mutant L179W also had a significant decrease in PL transfer activity but no change in HDL-binding, relative to wildtype PLTP. Also predicted to be localized at the entrance to the N-terminal lipid binding pocket, the mutant F447E was designed to disturb interactions with the nonpolar part of a lipid. This mutant had a significant decrease in PL transfer activity but an increase in HDL-binding, relative to wildtype PLTP. In all three N-terminal pocket mutants, the lack of correlation between activity and HDL-binding suggests that this pocket is involved in some other step of the PL transfer process.

Inside the C-terminal pocket, the mutations C318S and M260W had 20-40% inhibition of activity and 30% or mild decrease in HDL-binding, respectively. A third mutation, of a residue predicted to be located at the entrance to the C-terminal binding pocket, L269W, resulted in complete loss of activity and a drastically reduced capacity to bind HDL. As Leu269 is on the concave side of the protein, the lack of HDL-binding by the L269W mutant indicates that HDL may interact with PLTP on its concave surface. The close correlation between the HDL-binding capacity and the PL transfer activity of the C-terminal pocket mutants suggests that this pocket may be responsible for PLTP-HDL interactions. These studies show that both pockets of PLTP are essential for PL transfer activity. Double mutants, with one substituted residue from each pocket, all had

slightly less activity than the lower of the two individual mutants, suggesting that the two pockets function in tandem.

In the crystal structure of BPI, a cluster of positively charged residues is localized to the amino-terminal tip of the boomerang shape. These residues are conserved in LBP, and were found to participate in the interaction of LBP with the negatively charged LPS (Lamping et al. 1996). According to the structural model of LBP, this cluster of positive charge appears to be fully exposed at N-terminal tip of the protein (Beamer et al. 1998). The equivalent residues in PLTP are aromatic, hydrophobic residues, and in the PLTP model they are also predicted to be solvent exposed at the amino-terminal tip of the boomerang shape. Several of these hydrophobic amino acids are conserved in CETP. Single amino acid point mutations were made to six residues of PLTP, within this cluster, to address whether this region of the protein is involved in hydrophobic interactions with HDL (Desrumaux et al. 2001). The mutants Y45A, Y90A, W91A, F92A, F93A, and Y94A were all secreted although with variable efficiencies. Mutations to residues 90, 91, 92, and 93 had significantly decreased ability to transfer phospholipid from liposomes to HDL, or between HDL particles, and to remodel HDL. Only the Y90A mutant caused a reduction in the ability of PLTP to transfer PL from liposomes to VLDL or LDL substrates. These results suggest that this cluster of hydrophobic residues may be required specifically for interactions of PLTP with HDL.

There are six putative N-linked glycosylation sites within the PLTP sequence, at asparagine residues 47, 77, 100, 126, 228, and 381 (Day et al. 1994) There are also multiple putative O-linked glycosylation sites. This results in an observed molecular weight of plasma PLTP on reducing SDS-PAGE of about 81 kDa, although the calculated

molecular weight of the mature PLTP protein is 55 kDa. Glycosylation of PLTP is crucial for its secretion and activity (Huuskonen et al. 1998).

### **The Carboxy-Termini of CETP and PLTP**

When the amino acid sequences of human CETP and BPI are aligned, CETP extends for an additional 12 residues at the carboxy terminus, relative to BPI. This carboxy terminal 'tail' of CETP has been shown to be critical for protein function. First, a deletion mutant  $\Delta 470-475$  retains its ability to transfer PL and bind HDL, but has only 20% of the neutral lipid transfer activity of wildtype CETP (Wang et al. 1992; Wang et al. 1995). In addition, the monoclonal antibody TP2 binds specifically in the last 26 amino acids of CETP, and eliminates all CETP-mediated neutral lipid and PL transfer activity (Swenson et al. 1989; Wang et al. 1992). Predictions of secondary structure and circular dichroism measurements indicate that this region of CETP probably forms an amphipathic  $\alpha$ -helix (Bolanos-garcia et al. 1998). When this putative C-terminal helix is modeled into the proposed tertiary structure of CETP, it is predicted to lie across the opening of the amino-terminal lipid-binding pocket (Figure 6A) (Bruce et al. 1998b). Several amino acid mutations near the C-terminus decrease the secretion efficiency of CETP, either by disrupting the helical structure or its placement, highlighting the importance of both (Wang et al. 1993; Bruce et al. 1998b).

Point mutagenesis near the C-terminus of CETP showed that residues on the hydrophobic face of the amphipathic helix participate in neutral lipid transfer, and residues on the hydrophilic face bind TP2. However, the binding of CETP to TP2 actually causes an increase in the affinity of CETP for lipoproteins (Swenson et al. 1989).

One proposed mechanism for this is that antibody binding causes movement of the flexible tail, exposing the hydrophobic face, which in turn stabilizes hydrophobic interactions with lipoproteins. As mutations in the helix have little effect on PL transfer, or even stimulate it, perhaps this region of CETP is only involved in neutral lipid transfer. (Wang et al. 1992)

Although it is still unclear how the C-terminal helix of CETP could facilitate neutral lipid transfer, one mechanism that has been proposed is the 'tilted peptide' model (Brasseur et al. 1997; Bruce et al. 1998). According to this theory, the helix would interact with the lipoprotein surface at an angle relative to the phospholipid acyl chains, thereby disrupting their packing. A disruption such as this would release the contents of the lipoprotein core, allowing them to move into the lipid-binding pocket of CETP (Figure 7). In fact, it has been shown that a peptide of CETP residues 461-476 binds membranes in an oblique manner and causes the vesicle contents to leak out (Perez-Mendez et al. 1997).

When the amino acid sequence of human PLTP is aligned with BPI, PLTP also has an extension at the C-terminus, relative to BPI, in this case 28 residues long. A series of C-terminal deletion mutants showed that this region of PLTP is required for enzyme activity: removal of 5 or 10 residues from the C-terminal had no effect on PLTP activity, deletion of 20 or 25 residues reduced the activity to less than 40% of wildtype PLTP, deletion of 30 residues produced a secreted protein with no activity, and deletion of more than 35 residues resulted in a misfolded protein that was not secreted (Huuskonen et al. 1998). This study shows that the last 30 residues of PLTP are not required for overall protein folding. In contrast, extension of the deletion to 35 amino acids would disrupt the

**Figure 7. The 'tilted peptide' model of the CETP C-terminal helix.**

**A)** The carboxy-terminal helix of CETP (residues 465-476) interacts with the lipoprotein surface at an angle relative to the phospholipid plane. This causes a disruption of the packing of the phospholipid monolayer.

**B)** The disruption of the lipoprotein surface enables the neutral lipids within the core of the lipoprotein to move out of the lipoprotein core and into a lipid binding pocket of CETP.

A

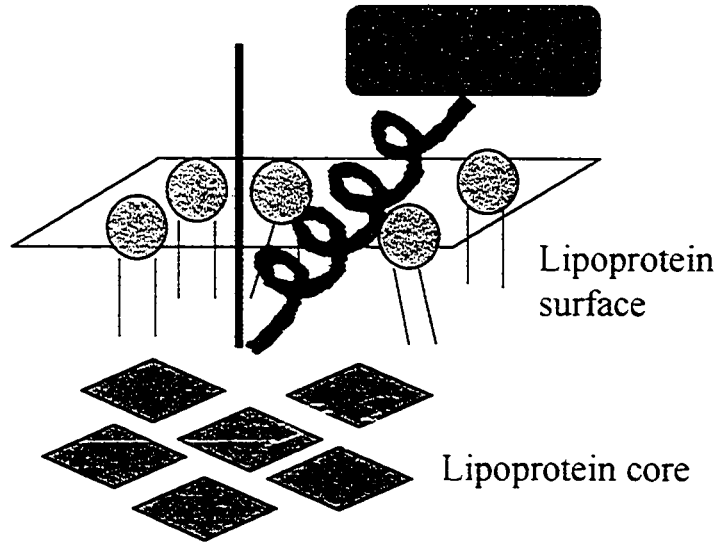

B

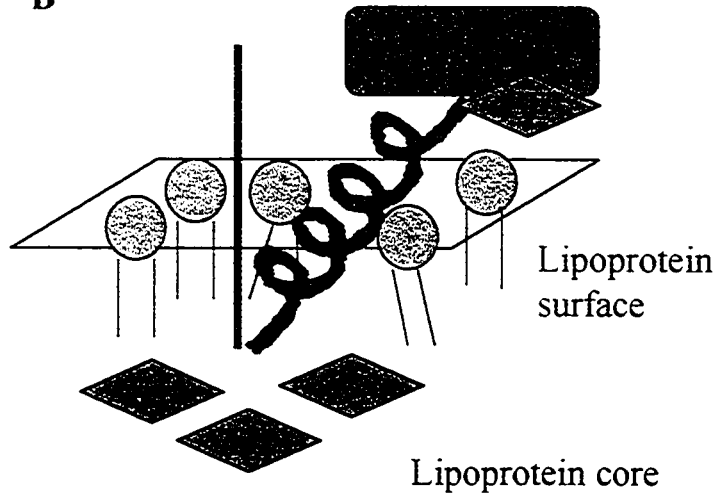

central  $\beta$ -sheet, causing a major folding defect. It also implicates residues 447 to 451 in PL transfer. The aromatic residue Phe447 is conserved in CETP and is substituted with a tyrosine in BPI and LBP. Antiserum against PLTP residues 453-476 does not recognize the inactive F447E mutant, perhaps because this residue is required for maintaining the conformation of the tail region (Huuskonen et al. 1999). Residues 445-456 of PLTP are predicted to form an  $\alpha$ -helix which may also be able to penetrate phospholipid monolayers or bilayers on an oblique angle, although this has not been tested (L. Lins and R. Brasseur, personal communication)

### **Rationale and Objectives**

Structural domain swaps, or 'chimeric' proteins are an invaluable tool for investigation of the functionality of individual domains in related proteins. BPI and LBP share about 45% amino acid identity in humans, and are predicted to have similar tertiary structures, yet they elicit opposing host responses to Gram-negative bacterial infection. LBP activates cells by delivering LPS to CD14, causing an inflammatory response in the host. In contrast, BPI decreases endotoxin-triggered inflammation by neutralizing LPS and opsonizing the bacteria. Chimeras of LBP and BPI have been used to determine the roles of the N- and C- terminal domains of each protein, and provide information about how such closely related proteins can differ so widely in function. The results of these studies confirmed that the amino-terminal domains of BPI and LBP are responsible for LPS binding, and the carboxy-terminal domains regulate the delivery of LPS to specific acceptors during the host response to Gram-negative bacterial infection. The C-terminal domain of LBP is required for CD14-dependent cell activation, whereas the C-terminal

domain of BPI is necessary for clearance of intact bacteria through an unknown mechanism (Abrahamson et al. 1997; Iovine et al. 2002).

PLTP and CETP are clearly key players in overall lipid metabolism; however, the structural basis for their lipid specificities are still unidentified. We were interested in whether the carboxy-terminal helix of CETP enables it to transfer CE and TG between lipoproteins, and whether the carboxy-terminal of PLTP enables it to transfer phospholipid from vesicles to lipoproteins. With the discovery of the 2-domain structure of BPI, and the subsequent structural models of PLTP and CETP, we were able to design and express several chimeric proteins in which the carboxy-terminal tails were swapped, in order to look for answers to these questions. Our hypothesis was that the carboxy-terminal tail regions of CETP and PLTP are the primary determinants of substrate specificity. Thus, we thought that a chimera composed of CETP with its tail replaced by the tail of PLTP would gain PLTP-like PL transfer activity, and a chimera composed of PLTP with the CETP tail would gain neutral lipid transfer activity. However, the results of this study seem to suggest that the carboxy-terminal tail alone is insufficient to determine the lipid specificity of each protein, and that both the C-terminal tail and other parts of the molecule are required for activity. Thus we prepared another two DNA constructs, each with one lipid binding pocket from each of PLTP and CETP, and both with the C-terminal helix of CETP. A schematic representation of our chimeric proteins is shown in Figure 8.

A second goal of this research was to produce and map the epitopes of a panel of monoclonal antibodies to human PLTP. These would be useful both for our current studies and for future structure-function studies of PLTP, as so far, very few anti-PLTP

**Figure 8. Schematic representation of PLTP, CETP, and chimeric proteins.**

The CETP amino acid sequence is shown in blue; the PLTP amino acid sequence in green. All constructs were prepared in the vector pCMV5. The full name of each construct is indicated on the left, with the abbreviation in parentheses. Numbering refers to amino acids in the mature proteins (not to scale).

CETP<sub>1-476</sub>



PLTP<sub>1-476</sub>-myc-HIS

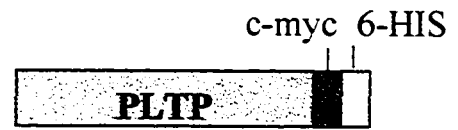

CETP<sub>1-460</sub>/PLTP<sub>445-476</sub>  
(CP)



CETP<sub>1-460</sub>/PLTP<sub>445-476</sub>-myc-HIS  
(CP-HIS)



PLTP<sub>1-444</sub>/CETP<sub>461-476</sub>  
(PC)



PLTP<sub>1-444</sub>/CETP<sub>461-464</sub>/GlyGly/CETP<sub>465-476</sub>  
(PGGC)

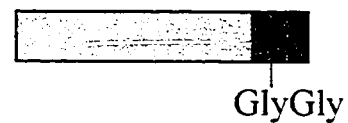

CETP<sub>1-16</sub>/PLTP<sub>11-184</sub>/CETP<sub>200-476</sub>  
(bpN-PLTP/bpC-CETP/CETP tail)



CETP<sub>1-266</sub>/PLTP<sub>253-418</sub>/CETP<sub>432-476</sub>  
(bpN-CETP/bpC-PLTP/CETP tail)



antibodies have been produced. We have attempted to produce monoclonal antibodies to PLTP using a standard protein immunization technique, and a more novel DNA immunization strategy in mice, as well as a synthetic peptide conjugate immunization in chickens.

## Chapter II: Materials and Methods

### Molecular biology

#### *Materials:*

Primers were from Gibco BRL Life Technologies (Carlsbad, CA) or from Sigma Genosys (Oakville, ON). T4 DNA ligase, dNTPs, Vent DNA polymerase, and restriction enzymes were from New England Biolabs (Beverly, MA). Pfu Turbo (2.5 U/ml) was from Strategene (LaJolla, CA). The DH5 $\alpha$  *Escherichia coli* cells were from the American Type Culture Collection (ATCC) (Rockville, MD), and were made competent by the method of Inoue (1990). Shrimp Alkaline Phosphatase was from Boehringer Mannheim (Germany). Miniprep spin kits, maxiprep kits, and the QIAEX II DNA extraction kit were from QIAGEN (Valencia, CA).

The expression vector pCMV5 was provided by Dr. D. Russell (University of Texas Southwestern Medical Center). The vectors PCR-BluntII-TOPO, pTrcHIS-B, and pcDNA3.1(-)BmycHIS were from Invitrogen Life Technologies. The cDNA for human PLTP, including the signal sequence, was initially obtained in pBK as a gift from Dr. X.C. Jiang (Columbia University, New York). The cDNA for human CETP, including the signal peptide, was originally a gift from Dr. D. Drayna (Genentech Inc., South San Francisco, CA). The expression construct CETP-pCMV5 contained the full-length sequence of human CETP, including the signal peptide, which had previously been subcloned in our laboratory into the EcoRI and HindIII sites of pCMV5.

### *General Cloning Methods:*

All constructs were derived from the parental plasmids PLTP-pBK and CETP-pCMV5, using various combinations of polymerase chain reactions (PCR) and restriction enzyme strategies. Primer sequences are shown in Table 2.

For subcloning purposes, restriction digests were done for 3-18 hours to ensure complete digestion, followed by inactivation at 65°C for 15 minutes. Cut vector was treated with shrimp alkaline phosphatase for 30-90 minutes at 37°C, followed by inactivation at 65°C for 15 minutes. Fragments were isolated from agarose using the QIAEX II extraction kit according to the manufacturer's instructions. Ligations were done overnight at room temperature, with 1 µl T4 DNA ligase, using molar ratios of vector to insert of 1:1 up to 1:10, with a total of 200-300 ng DNA per reaction in 10-20 µl total reaction volume. Either half or all of the ligation mixture was used for transformation of *E.coli*.

Mutagenic PCR was done according to the instructions for the QuikChange Site-Directed Mutagenesis Kit (Stratagene). Successful PCR was confirmed by running a small sample of the product on agarose gel. The PCR product was then digested with DpnI for 1-2 hours to remove template DNA prior to transformation of *E.coli*. Inverse PCR was done according to the method of Gama and Breitwieser (1999), and following the guidelines provided for the PfuTurbo DNA polymerase (Stratagene). A small sample of the PCR product was run on an agarose gel to check for successful amplification. The PCR product was digested with DpnI at 37°C for 60 minutes, followed by an additional extension time of 30 minutes at 72°C. The DpnI-digested DNA

**Table 2. The sequences of oligonucleotides used for molecular biology.**

Primers were used in subcloning of DNA to generate plasmids to express chimeric proteins, as described in 'Materials and Methods' All sequences are shown as 5' to 3'. Phosphorylation is indicated by P\*. New restriction sites are underlined. The amino acid numbers corresponding to the mature protein sequences are shown in parentheses.  
(continued on following page)

Primers for cloning wildtype PLTP expression constructs

|   |   |
|---|---|
| 5' PLTP EcoRI<br>(PLTP -3 to 5)         | GCACATGCAGAAT <u>CCCCAGGCTGC</u>        |
| 3' PLTP-stop-EcoRI<br>(PLTP 473 to 476) | GGGATTGAGAAT <u>TCAGACAGCTGCTGTGG</u>   |
| 5' PLTP-XbaI<br>(PLTP -17 to -14)       | CTGAGCCCGCT <u>CTAGATGGCCCTCTTC</u>     |
| 3' PLTP-XbaI<br>(PLTP 473 to 476)       | GGATTGAGGT <u>CTAGAACAGCTGCTGTGGACG</u> |
| 3' PLTP-stop-XbaI<br>(PLTP 474 to 476)  | CTTGGGGAT <u>CTAGAGCTCAGACAGCTGC</u>    |

Primers for cloning 'PC' and 'PGGC'

|  |   |
|--|---|
| PLTP ClaI Fwd<br>(PLTP 437 to 446)                                     | GGATTCCTCACC <u>ATCGATGCTGATCTCCAC</u>                              |
| PLTP ClaI Rev<br>(PLTP 437 to 446)                                     | GTGGAGATCAGC <u>ATCGATGGTGAGGAATCC</u>                              |
| PLTP-CETP C-term<br>Coding (PLTP 443 to 444<br>and CETP 461 to 476)    | CGGGGCTGACTTTGGCTTCCCTGAGCACCTGCTG-<br>GTGGATTTCCTCCAGAGCTTGAGCTAG  |
| PLTP-CETP C-term<br>Noncoding (PLTP 443 to<br>444 and CETP 461 to 476) | TAACTAGCTCAAGCTCTGGAGGAAATCCACCAG-<br>CAGGTGCTCAGGGAAGCCAAAGTCAGCCC |
| PLTP-GlyGly-CETP-Rev<br>(CETP 461 to 464)                              | P*- TCCAGGGAAGCCAAAGTCAGCC  |
| PLTP-GlyGly-CETP-Fwd<br>(CETP 465 to 471)                              | P*-GGAGAGCACCTGCTGGTGGATTTC   |

Primers for cloning 'CP' and 'CPHIS'

|                                    |   |
|------------------------------------|---|
| CETP-ClaI Fwd<br>(CETP 451 to 463) | CGAGATGGCTTCCCTGCTG <u>ATCGATATGGACTTT-</u><br>GGCTTC |
| CETP-ClaI Rev<br>(CETP 451 to 463) | GAAGCCAAAGTCCAT <u>ATCGATCAGCAGGAAGC-</u><br>CATCTCG  |

**Table 2. The sequences of oligonucleotides used for molecular biology.**

Primers were used in subcloning of DNA to generate plasmids to express chimeric proteins, as described in 'Materials and Methods'. All sequences are shown as 5' to 3'. Phosphorylation is indicated by P\*. New restriction sites are underlined. The amino acid numbers corresponding to the mature protein sequences are shown in parentheses.  
(continued from previous page)

|   |   |
|---|---|
| CETP-PLTP Fwd<br>(CETP 454 to 460 and<br>PLTP 445 to 448) | GCTTCCTGCTGCTCCAGATGGATCTCCA<br>CTTTGC  |
| CETP-PLTP Rev<br>(CETP 454 to 460 and<br>PLTP 445 to 448) | GCAAAGTGGAGATCCATCTGGAGCAGCAG-<br>GAAGC |
| CP-deleteSTOP-Fwd<br>(PLTP 472 to 476)                    | CGTCCACAGCAGCTGTAGCGCTAGAACA<br>AAAAC   |
| CP-deleteSTOP-Rev<br>(PLTP 472 to 476)                    | GTTTTTGTCTAGCGCTACAGCTGCTGTGG<br>ACG    |
| <u>Primers used for cloning binding pocket chimeras</u>   |   |
| A. CETP-NheI (390)-fwd<br>(CETP 66 to 74)                 | CCACTTGTCCATCGCTAGCAGCCAGGTGG           |
| B. CETP-Nhe (390)-rev<br>(CETP 66 to 74)                  | CCACCTGGCTGCTAGCGATGGACAAGTGG           |
| C. CETP-16-rev<br>(CETP 7 to 16)                          | P*-GGTGATGCGGCACACGATGCCTGCCTCGTGC      |
| D. PLTP-11-fwd<br>(PLTP 11 to 20)                         | P*-TCCAAGGCGCTGGAGCTGGTGAAGCAGGAGGG     |
| E. PLTP-184-rev<br>(PLTP 176 to 184)                      | P*-GTCCAGGAGTGAGTTAAGCAGGACCGTCC        |
| F. CETP-200-fwd<br>(CETP 200 to 208)                      | P*-ACAAGGGCTGCCAGCATCCTGTCAGATGG        |
| G. CETP-NheI(1007)-fwd<br>(CETP 272 to 279)               | CTCGCTGGCCAAGCTAGCTTTCCAGG              |
| H. CETP-NheI(1007)-rev<br>(CETP 272 to 279)               | CCTGGAAAGCTAGCTTGGCCAGCGAG              |
| I. CETP-266-rev<br>(CETP 257 to 266)                      | P*-AGAGAACCAGAAGTACAGCATGCGGGAGTC       |
| J. PLTP-253-fwd<br>(PLTP 253 to 262)                      | P*-GAGTTCTTCTTCGACTCTGCCATGGAGAGC       |
| K. PLTP-418-rev<br>(PLTP 409 to 418)                      | P*-CTGCACTCCACGCCAAGTCCTCTCATTGAGC      |
| L. CETP-432-fwd<br>(CETP 432 to 441)                      | P*-CTCATGAACAGCAAAGGCGTGAGCC-TCTTCG     |

was ligated overnight at room temperature, in the presence of T4 DNA ligase and ATP. Enzymes were inactivated at 65°C for 10 minutes before transformation of *E.coli*.

Bacteria were grown on Luria-Bertaini (LB) agar plates containing 50 µg/ml ampicillin, and colonies for analysis were picked and grown in 2 ml of liquid LB also containing 50 µg/ml ampicillin. Plasmid DNA was isolated by alkaline lysis (Sambook et al. 1989), or using the Qiagen spin miniprep kit when the sample was to be used for DNA sequencing. Larger-scale preparations of the plasmid DNA were done using the QIAGEN maxiprep kit according to the manufacturer's instructions.

*Cloning of wildtype human PLTP expression constructs:*

The sequence coding for the mature PLTP was amplified from PLTP-pBK, by PCR using the primers 5'PLTP-EcoRI and 3'PLTP-STOP-EcoRI, according to the guidelines for Vent DNA polymerase. The PCR product was digested with EcoRI, isolated from agarose gel, and ligated into EcoRI-cut PCR-BluntII-TOPO. The PLTP coding sequence was then subcloned into pTrcHISB, using EcoRI, such that the N-terminal hexaHIS epitope was in frame with the mature PLTP protein. The correct coding sequence in the bacterial expression construct PLTP-HIS-pTrcHIS was verified by DNA sequencing.

The primers 5'PLTP-XbaI and 3'PLTP-STOP-XbaI were used to PCR amplify the full-length PLTP sequence including the signal peptide and the STOP codon from the PLTP-pBK plasmid, adding XbaI sites at both ends. Similarly, the primers 5'PLTP-XbaI and 3'PLTP-XbaI were used to PCR amplify the PLTP sequence without the STOP codon from the PLTP-pBK plasmid, adding XbaI sites at both ends. Each PCR product

was digested with XbaI, isolated from agarose gel, and ligated into XbaI cut pcDNA3.1(-)B-mycHIS. In the first case, the resulting plasmid is PLTP-pcDNA3.1, used to express wildtype hPLTP. In the second case, the PLTP sequence is in frame with the sequence coding for the c-myc and hexaHIS epitopes at the 3' end of the MCS, so that the resulting plasmid, PLTP-mycHIS-pcDNA3.1 expresses hPLTP with c-myc and 6-HIS tags at its C-terminal. In order to express PLTP using the same vector as CETP, the DNA coding for the PLTP plus the c-myc and hexaHIS tags was isolated by digestion of the PLTP-mycHIS-pcDNA3.1 plasmid with PmeI, a blunt-cutter. The PmeI fragment was then subcloned into pCMV5 at the SmaI site of the MCS, to generate the expression construct PLTP-mycHIS-pCMV5. The correct PLTP coding sequence was confirmed by restriction digests and DNA sequencing.

*Cloning of PLTP/CETP tail Chimeras:*

The cloning strategies for the constructs PLTP<sub>1-444</sub>/CETP<sub>461-476</sub>-pCMV5 ('PC') and PLTP<sub>1-444</sub>/CETP<sub>461-464</sub>/GlyGly/CETP<sub>465-476</sub>-pCMV5 ('PGGC') are shown in Figure 9. A unique ClaI site was generated in PLTP-pcDNA3.1, at PLTP residue 441, by PCR mutagenesis using primers PLTP-ClaI-fwd and PLTP-ClaI-rev. The resulting plasmid, PLTP-ClaI-pcDNA3.1, was digested with ClaI and AflIII, which cuts at the 3' end of the MCS of pcDNA3.1, and the 6kb fragment was isolated. Coding and non-coding oligos for PLTP residues 441 to 444, and CETP residues 461 to 476, with ClaI and AflIII compatible ends, were annealed by incubating equal amounts of the single stranded primers in annealing buffer (10 mM Tris-HCl, pH 7.5, 100 mM NaCl, 1 mM EDTA) at 95°C for 2 minutes, followed by slow cooling to room temperature. The double-stranded

**Figure 9. Cloning of PLTP/CETP tail chimeras**

**A) PLTP<sub>1-444</sub>/CETP<sub>461-476</sub>-pCMV5 (PC)**

1: a new ClaI site was added to PLTP-pcDNA3.1 at PLTP residue 441 by mutagenic PCR. 2: PLTP-ClaI-pcDNA3.1 was digested with ClaI and AflII, and the 6kb fragment was isolated. 3: this fragment was ligated to a double-stranded oligo coding for CETP residues 441-476. 4: The sequence coding for PLTP<sub>1-444</sub>/CETP<sub>461-476</sub> was subcloned into pCMV5.

**B) PLTP<sub>1-444</sub>/CETP<sub>461-464</sub>/GlyGly/CETP<sub>465-476</sub>-pCMV5 (PGGC)**

Inverse PCR was used to insert 2 glycine residues into the PC DNA, between CETP residues 464 and 465.

Numbering refers to amino acids in the mature proteins.

**A**

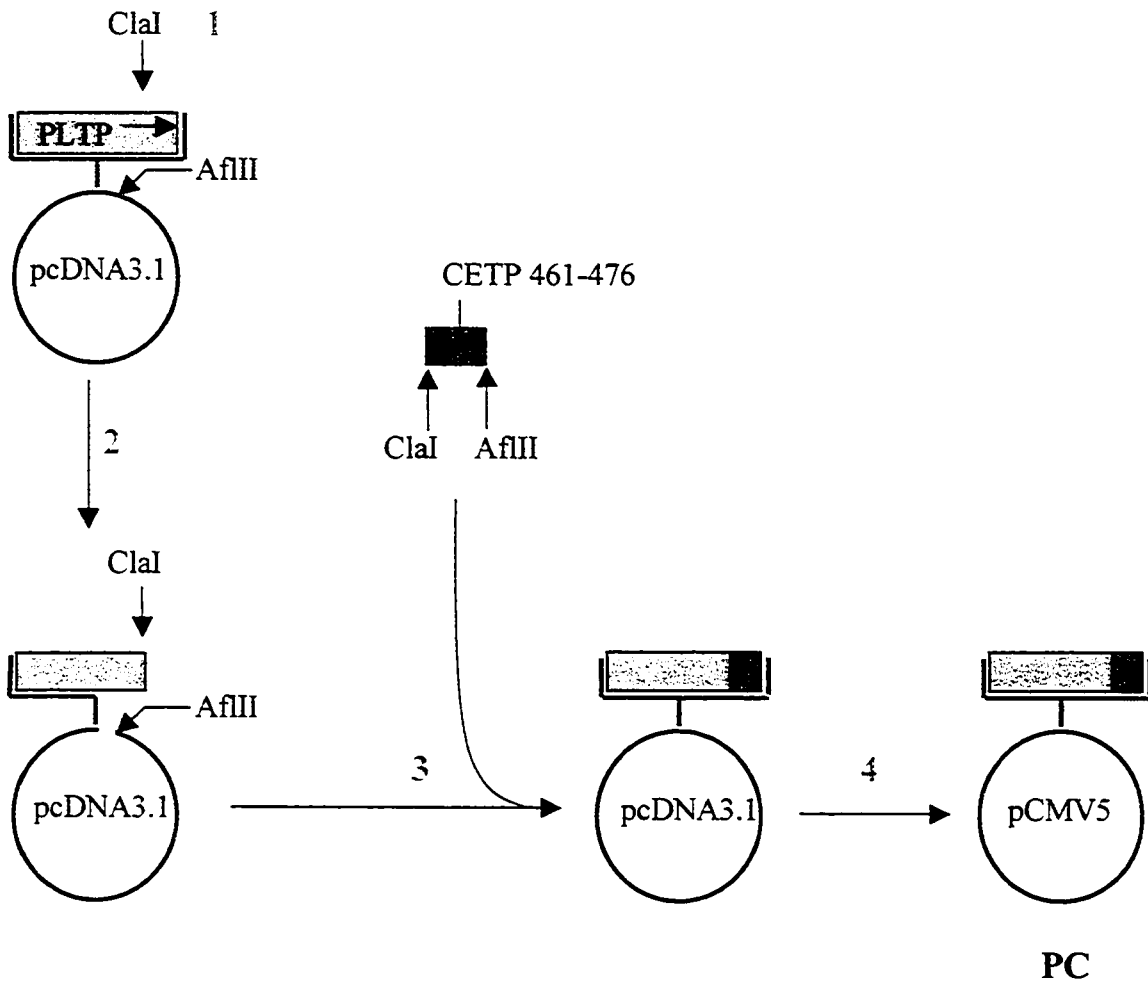

**B**

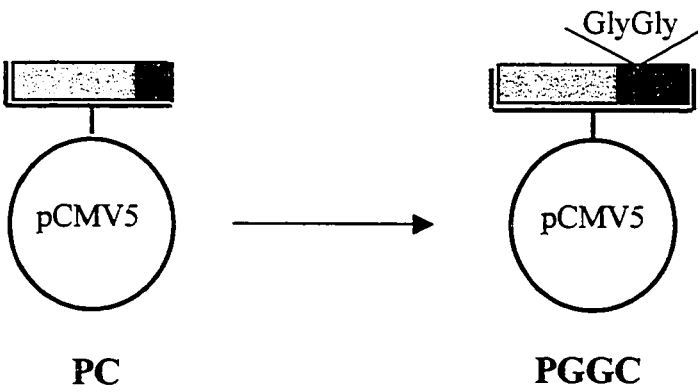

oligo was then ligated into the ClaI-AlfII cut PLTP-ClaI-pcDNA3.1. This generated the construct PLTP<sub>1-444</sub>/CETP<sub>461-476</sub>-pcDNA3.1. In order to generate the final expression construct, PLTP<sub>1-444</sub>/CETP<sub>461-476</sub>-pCMV5, the sequence coding for PLTP<sub>1-444</sub>/CETP<sub>461-476</sub> was isolated from pcDNA3.1 by digestion with PmeI, and subcloned into the SmaI site of pCMV5. The orientation and coding sequence was confirmed by restriction digests and DNA sequencing. Two glycine residues were inserted into the 'PC' construct between CETP residues 464 and 465 by inverse PCR with primers PLTP-GlyGly-CETP-fwd and PLTP-GlyGly-CETP-rev to generate the 'PGGC' construct. The presence of the desired coding sequence was confirmed by DNA sequencing.

*Cloning of CETP/PLTP tail chimeras:*

The cloning strategies for the chimeras CETP<sub>1-460</sub>/PLTP<sub>445-476</sub>-pCMV5 ('CP') and CETP<sub>1-460</sub>/PLTP<sub>445-476</sub>-mycHIS-pCMV5 ('CP-HIS') are shown in Figure 10. A unique ClaI site was generated in CETP-pCMV5, just upstream of CETP residue 460, by PCR mutagenesis using primers CETP-ClaI-fwd and CETP-ClaI-rev. The sequence coding for PLTP residues 445-476 was obtained from the plasmid PLTP-ClaI-pcDNA3.1 by isolating the small fragment resulting from digestion with ClaI and PmeI, and was ligated into ClaI/SmaI cut CETP-ClaI-pCMV5. A second mutagenic PCR was performed with primers CETP-PLTP-fwd and CETP-PLTP-rev, in order to revert the sequence back to the correct coding sequence where the restriction site had been added in the first step. In the CP construct, the DNA encoding the c-myc and hexaHIS epitopes are present. However, the epitopes are not expressed due to the STOP codon at the 3' end of the PLTP coding sequence. Thus to generate the plasmid CETP<sub>1-460</sub>/PLTP<sub>445-476</sub>-mycHIS-

**Figure 10. Cloning of CETP/PLTP tail chimeras.**

**A) CETP<sub>1-460</sub>/PLTP<sub>445-476</sub>-pCMV5 (CP)**

1: A new ClaI site was generated in CETP-pCMV5, upstream of CETP residue 460, by mutagenic PCR. 2a: CETP-ClaI-pCMV5 was digested with ClaI and SmaI and the large fragment was isolated. 2b: PLTP-ClaI-pcDNA was digested with ClaI and PmeI, and the small fragment coding for PLTP residues 445 to 476 was isolated. 3: The two fragments from step 2 were ligated together. 4: The ClaI site was removed by mutagenic PCR to regenerate the correct coding sequence at CETP residue 460.

**B) CETP<sub>1-460</sub>/PLTP<sub>445-476</sub>-myc-HIS-pCMV5 (CP-HIS)**

The stop codon (red hexagon) between PLTP residue 476 and the c-myc and 6-HIS epitopes in the CP construct was deleted by mutagenic PCR.

Numbering refers to amino acids in the mature proteins.

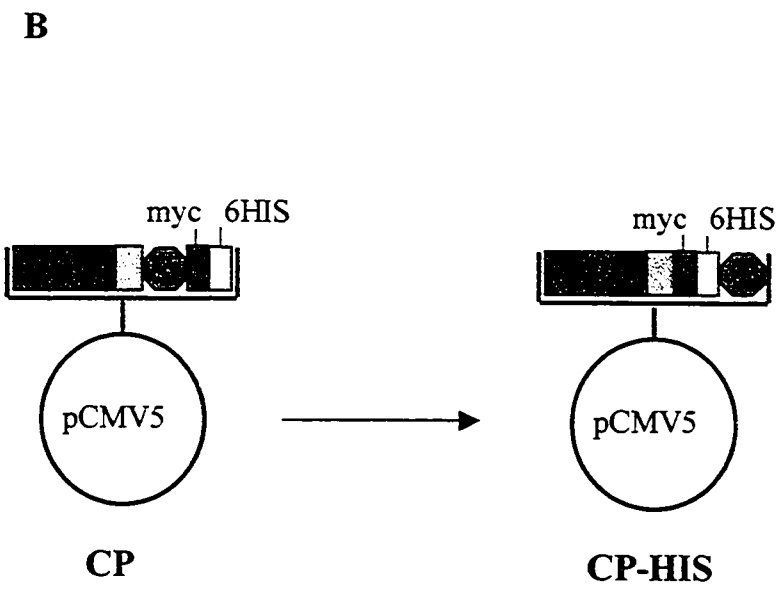
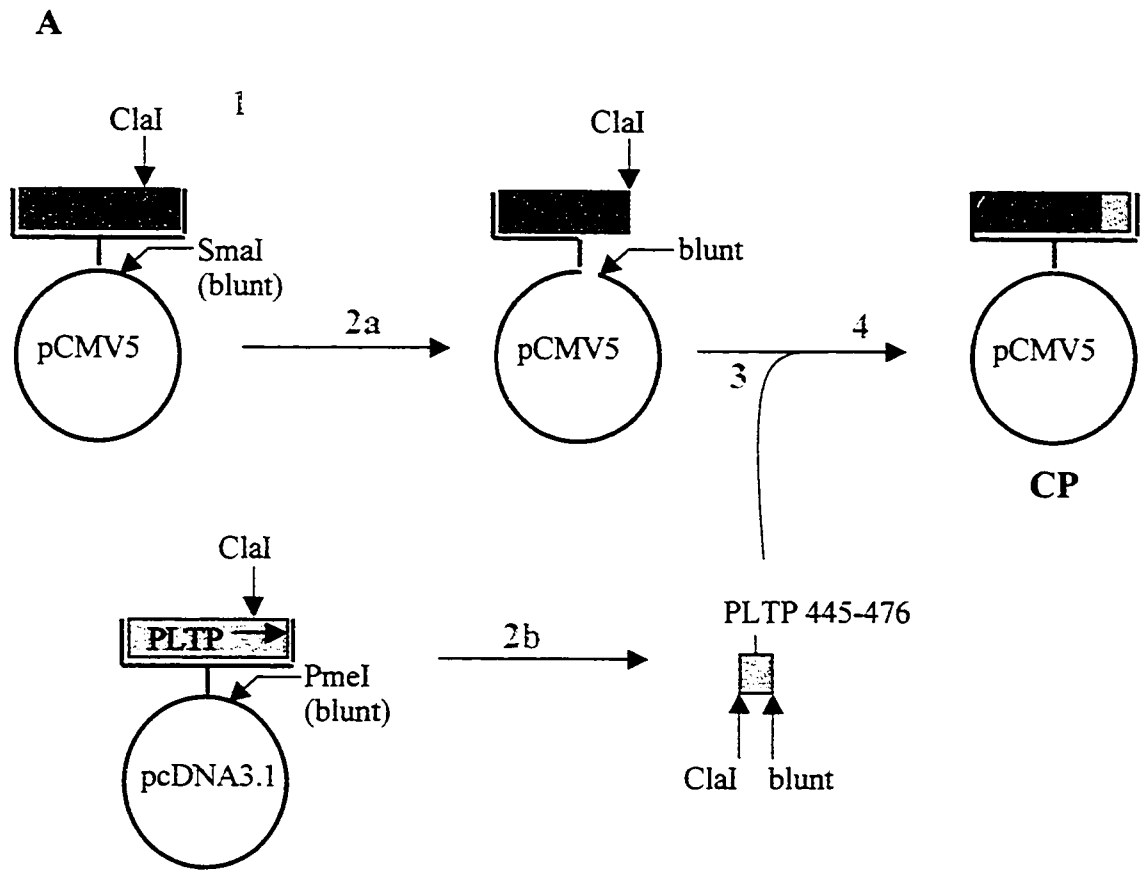

pCMV5, the stop codon was removed by PCR using the primers 'CP- deleteSTOP-fwd and 'CP-deleteSTOP-rev'. The coding sequences of each construct were checked by restriction digests and DNA sequencing.

*Cloning of CETP/PLTP Binding pocket chimeras:*

A 'monster chimera' strategy was employed to generate two binding pocket chimeras (Yang and Zwieb 2001). First, a large region of the PLTP sequence was inserted into the middle of the CETP sequence, and then excess, unwanted regions of DNA were deleted by 2 sequential inverse PCR amplifications. Each intermediate plasmid was checked by restriction digests, and maxipreps of the DNA were made at each stage. The entire coding sequences of the final plasmids were confirmed by DNA sequencing. A representation of the cloning strategy is shown in Figure 11.

*A: CETP<sub>1-16</sub>/PLTP<sub>11-184</sub>/CETP<sub>200-476</sub>-pCMV5 (bpN-PLTP/bpC-CETP/CETPtail):*

A unique NheI site was added to CETP-pCMV5 at basepair 390 (residue 70 of CETP) by mutagenic PCR using primers A and B. An 1100bp fragment encoding the first ~330 residues of PLTP was obtained by digesting PLTP-pcDNA3.1 with XbaI and NheI. This fragment was ligated into NheI-cut CETP-NheI(390)-pCMV5. The orientation of the PLTP coding sequence in the 'monster' construct was checked by restriction digests before continuing. Primers E and F were used in the first inverse PCR reaction to amplify the 'monster chimera' excluding the unwanted region between PLTP residue 184 and CETP residue 200. In the second inverse PCR reaction, primers C and D were used to amplify the product of the first PCR, excluding the region between CETP residue 16 and PLTP residue 11.

**Figure 11. Cloning of binding pocket chimeras by the ‘monster chimera’ strategy.**

Numbers refer to amino acids in the mature wildtype proteins. Residues from CETP are shown in blue, and residues from PLTP are shown in green. The approximate locations of primer sequences are indicated as arrows. Only the coding sequence is depicted (not to scale).

**A) CETP<sub>1-16</sub>/PLTP<sub>11-184</sub>/CETP<sub>200-476</sub>**

1: a unique NheI site is generated in CETP-pCMV5 by site directed mutagenesis at CETP residue 70. 2: PLTP-pcDNA3.1 is digested with XbaI and NheI, and the fragment encoding PLTP residues 1-330 is ligated into the CETP at the NheI site, to generate ‘monster chimera A’. 3: an inverse PCR reaction using primers E and F amplifies the entire plasmid, excluding the region between PLTP residue 184 and CETP residue 200. 4: a second inverse PCR reaction with primers C and D amplifies the plasmid, excluding the region between CETP residue 16 and PLTP residue 11.

**B) CETP<sub>1-266</sub>/PLTP<sub>253-418</sub>/CETP<sub>432-476</sub>**

1: a unique NheI site is generated in CETP-pCMV5 by site directed mutagenesis at CETP residue 275. 2: PLTP-pcDNA3.1 is digested with XbaI, and the fragment encoding the entire PLTP sequence is ligated into the CETP at this NheI site, to generate the ‘monster chimera B’. 3: an inverse PCR reaction with primers I and J amplifies the plasmid, excluding the region between CETP residue 266 and PLTP residue 253. 4: a second PCR reaction using primers K and L amplifies the plasmid, excluding the region between PLTP residue 418 and CETP residue 432.

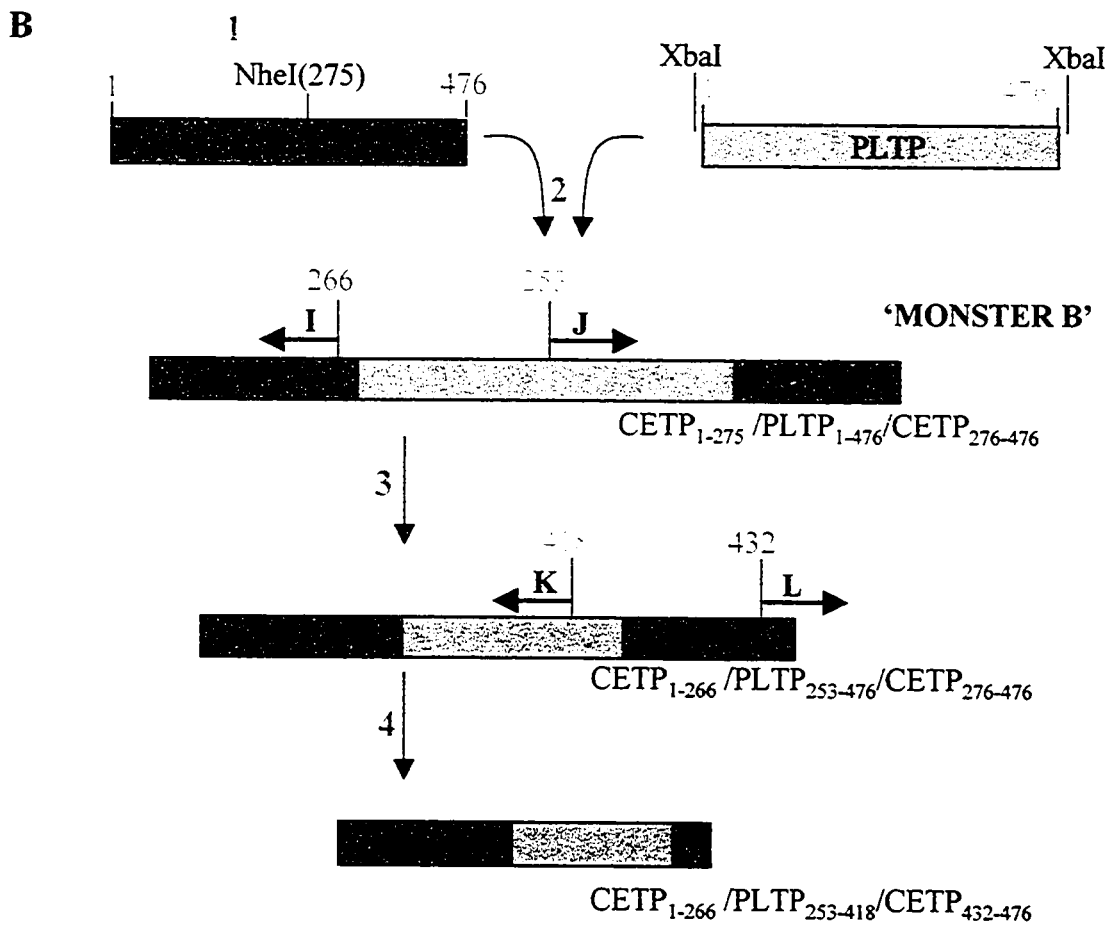
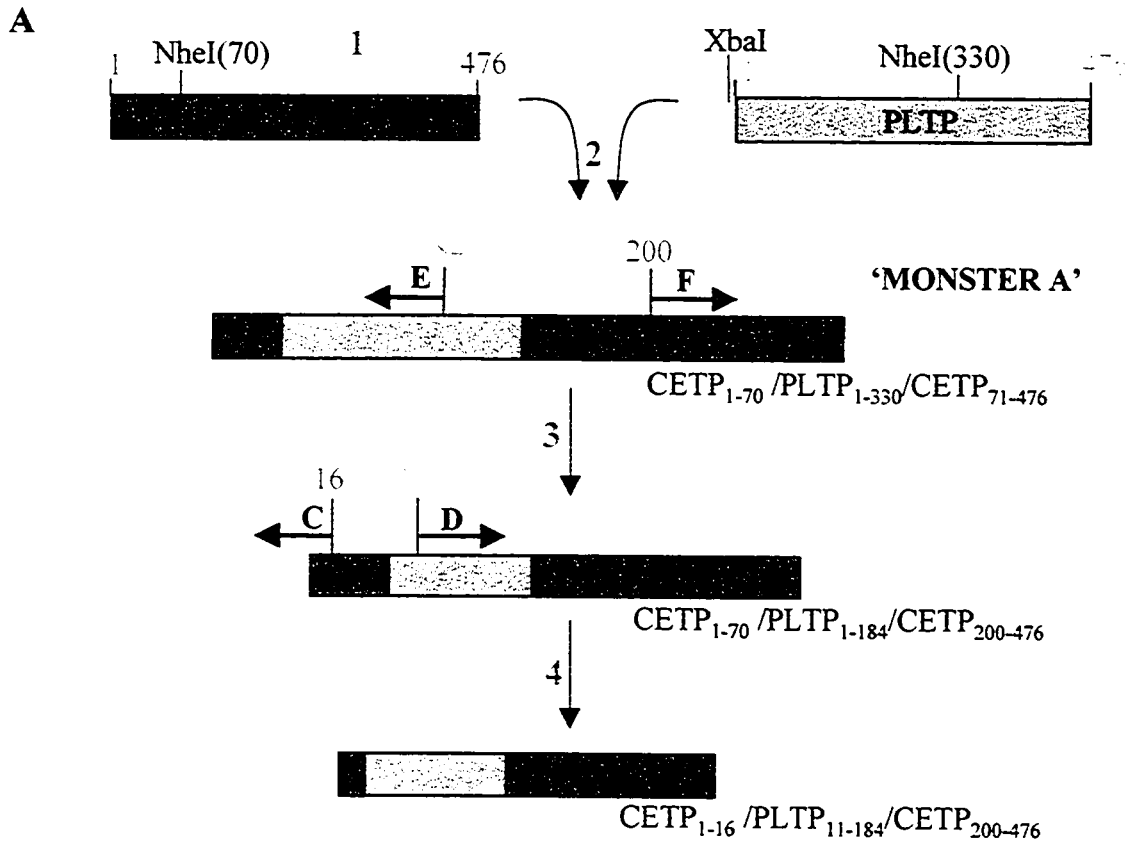

*B: CETP<sub>1-266</sub>/PLTP<sub>253-418</sub>/CETP<sub>432-476</sub>-pCMV5 (bpN-CETP/bpC-PLTP/CETPtail):*

A unique *NheI* site was added to CETP-pCMV5 at basepair 1007 (residue 275 of CETP) by PCR using primers G and H. A 1500bp fragment encoding the entire PLTP sequence was obtained by digesting PLTP-pcDNA3.1 with *XbaI*, and was ligated into *NheI*-cut CETP-*NheI*(1007)-pCMV5. The orientation of the PLTP insert in the 'monster chimera' was checked by restriction digests before continuing. Primers I and J were used in the first inverse PCR reaction to amplify the 'monster chimera' excluding the unwanted region between CETP residue 266 and PLTP residue 253. In the second inverse PCR reaction, using primers K and L, the region between PLTP residue 418 and CETP residue 432 was removed.

### **Expression and Relative Quantification of Immunoreactive Protein**

#### *Materials:*

COS-7 cells (Monkey kidney) were from ATTC. Cell culture media, L-glutamine, penicillin/streptomycin, trypsin, lipofectamine (2mg/ml), and precast Novex SDS acrylamide gels were from Gibco/Invitrogen Life Technologies. Fetal calf serum was from Sigma (St.Louis, MO). Complete, EDTA-free protease inhibitor tablets were from Roche (Germany). Nitrocellulose membrane and the slot-blotting apparatus were from BioRad (Hercules, CA). The production and characterization of the anti-human CETP monoclonal antibodies has been described previously (Roy et al. 1996; Guyard-Dangremont et al. 1999). The hybridoma clone for the anti-myc monoclonal antibody 9E10 was obtained from ATCC, and IgG was purified from ascites according to standard methods (Milne et al. 1992). The mAb to the oligohistidine tag (anti-HIS) was

from Cedarlane (Hornby, ON). A linear epitope map of the primary mAbs used is shown in Figure 12. The secondary antibody was a sheep anti-mouse IgG conjugated to horseradish peroxidase from Amersham Pharmacia Biotech (England). The enhanced chemiluminescent (ECL) substrate used for Western blotting was Supersignal West Pico from Pierce (Rockford, IL).

#### *Expression of Proteins in COS-7 Cells:*

COS-7 Cells were maintained in DMEM with 10% FBS, 2 mM L-glutamine, 0.10 standard units/ml penicillin and 0.10 µg/ml streptomycin, in 10 cm dishes, by splitting 1/10 every 3 to 4 days. Confluent cells were split 1/3 into 6-well dishes and grown for 24 hours before transfection. Transfection was done according to manufacturer's instructions, in OPTI-MEM with 1 µg DNA and 12 µg lipofectamine per 35 mm well. After a 5 hour incubation at 37°C, 1 ml of growth media containing 20% FBS was added and the cells were left at 37°C overnight. On the day following transfection, the media was replaced by OPTI-MEM and the cells were left to grow for a further 48 hours before harvesting cells and media.

The media was removed, centrifuged for 5 min at 1000RPM to spin down dead cells, transferred to a fresh tube, and 0.05% azide and protease inhibitor cocktail (1 tablet per 50 ml of media) were added. The cells were rinsed once in physiological PBS (137 mM NaCl, 2.7 mM KCl, 7.6 mM Na<sub>2</sub>HPO<sub>4</sub>, 1.5 mM KH<sub>2</sub>PO<sub>4</sub>, pH 7.4), scraped into an Eppendorf tube, spun down briefly at 12,000g, and lysed in 50 µl of TritonX-100 lysis buffer per well (200 mM Tris maleate pH 6.0, 2 mM CaCl<sub>2</sub>, 1.4% (w/v) TritonX-100). After a 30 minute incubation on ice, debris was spun down at 12,000 g for 5 minutes.

**Figure 12. Epitopes of monoclonal antibodies.**

**A)** A linear epitope map of anti-CETP monoclonal antibodies used in this study (not to scale). (Roy et al. 1996; Guyard Dangremont et al. 1999)

**B)** PLTP was expressed with C-terminal c-myc and hexaHIS epitopes, and mAbs to these epitopes were used for detection of PLTP (not to scale)

**C)** A summary of the antibodies used to detect PLTP, CETP, and the chimeric proteins PC, CP, and CP-HIS

Numbering refers to amino acids in the mature proteins.

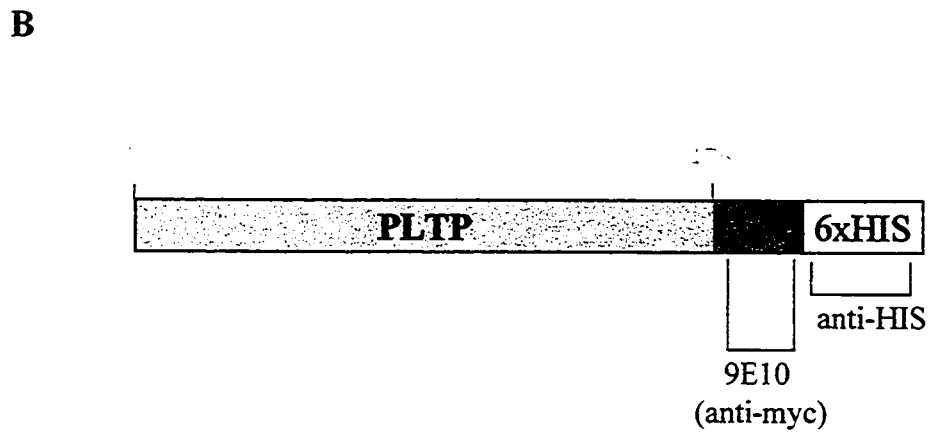
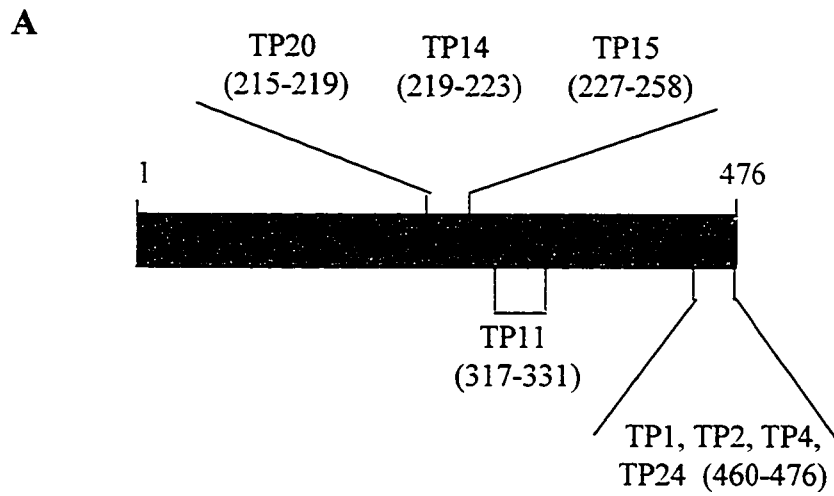

**C**

|          | TP1, TP2, TP4, TP24 | TP11, TP14, TP15, TP20 | anti-HIS | 9E10 |
|----------|---------------------|------------------------|----------|------|
| PLTP-HIS |                     |                        | ✓        | ✓    |
| CETP     | ✓                   | ✓                      |          |      |
| PC       | ✓                   |                        |          |      |
| CP       |                     | ✓                      |          |      |
| CP-HIS   |                     | ✓                      | ✓        | ✓    |

The supernatant was collected and an equal volume of 2x protein sample buffer (125 mM Tris-HCl, pH 6.8, 20% glycerol, 4% SDS, 5%  $\beta$ -mercaptoethanol) was added to the lysate.

PLTP, CETP and chimeric proteins in both cells and media of transfected cells were analysed by Western blot to check transfection efficiency, secretion, and degradation. An equal volume of 25% TCA was added to media samples (75 to 100  $\mu$ l), and after a 30 minute incubation on ice, proteins were precipitated by centrifugation at 12,000 g for 5 minutes. The supernatant was discarded, and the pellet was dissolved directly in an appropriate volume of 2x protein sample buffer for gel loading.

Samples were run under reducing conditions on 8 or 10% SDS acrylamide gels at 125V for about 2 hours, and transferred to nitrocellulose membrane at 4°C for 90 minutes at 100V. Membranes were blocked in 5% skim milk in PBS for at least 30 minutes at room temperature, and incubated with the appropriate antibody in blocking solution overnight at 4°C. Blots were washed a minimum of 3 times for 10 minutes each, in PBS (50 mM sodium phosphate, 150 mM NaCl, 0.05% (w/v) sodium azide, 1 mM EDTA) followed by incubation with secondary antibody diluted in blocking solution, for 1 hour at room temperature. The blots were washed as previously and chemiluminescent substrate applied before exposing to x-ray film for 2 to 40 minutes.

#### *Quantifying Immunoreactive Proteins:*

Once the presence of each protein in the media was confirmed by Western Blot, relative amounts of immunoreactive protein were quantified by application of serial dilutions of media directly onto nitrocellulose membrane via a slot blot apparatus,

according to the manufacturer's instructions. Mock transfection media and PBS alone were applied as negative controls. Blotting was performed as described for Western Blots. Bands were scanned on a densitometer (BioRad) and analysed using the Quantity One software (BioRad). For relative quantification using slot blots, PLTP and CPHIS were detected with 9E10; CETP, CP, and CPHIS with TP11; and CETP and PC with TP24. When samples were to be used for determination of relative PLTP activity, each protein concentration was determined relative to wildtype PLTP. Similarly, for determination of relative CETP activities, each protein concentration was quantified relative to wildtype CETP.

### **Lipid Transfer Activities of Wildtype and Chimeric Proteins**

#### *Materials:*

Plasma was obtained from normolipidemic subjects. [ $1\alpha,2\alpha(n)$ - $^3\text{H}$ ]cholesteryl oleate and L-3-phosphatidylcholine,1,2-di[ $1$ - $^{14}\text{C}$ ]palmitoyl were from Amersham Pharmacia Biotech (England). [ $9,10$ - $^3\text{H(N)}$ ]-Triolein was from Perkin Elmer. Heparin Sodium (10,000 units/ml) was from Organon Teknika Inc. (Toronto, ON).

#### *Isolation and Labeling of Lipoproteins:*

Lipoproteins were isolated by preparative sequential ultracentrifugation using solid KBr to adjust densities (Havel et al. 1955). LDL, HDL, and HDL<sub>3</sub> were isolated as the plasma fractions  $1.019 < \rho < 1.063$  g/ml,  $1.063 < \rho < 1.21$ , and  $1.125 < \rho < 1.21$ , respectively. After isolation, lipoproteins were dialyzed extensively in TBS (10 mM Tris, 150 mM NaCl, 0.05% (w/v) sodium azide, 1 mM EDTA, pH 7.4). Protein

concentration was analyzed using a BCA assay (Pierce) with BSA as a standard, and total cholesterol was determined using a commercial kit (Roche).

HDL labeled with  $^3\text{H}$ -cholesteryl ester was prepared by rapidly injecting 100  $\mu\text{Ci}$  of cholesteryl oleate dissolved in ethanol directly into a mixture of 5 mg of HDL, protease inhibitors, glutathione (0.01% final), and LPDS (approximately 50 mg protein; heat inactivated to remove LCAT activity), and rotating gently at  $37^\circ\text{C}$  for 30-48 hours. Following the incubation, the HDL was reisolated by ultracentrifugation as described.

LDL containing  $^3\text{H}$ -triolein was prepared by incubating 40 ml of fresh human plasma with  $^3\text{H}$ -triolein-containing vesicles, in the presence of EDTA (1 mM), sodium azide (0.05% (w/v)), and protease inhibitors (1 tablet), with gentle rotation at  $37^\circ\text{C}$  for 18 hours. Following the incubation, the LDL was isolated by ultracentrifugation as described. The vesicles were made from a mixture of POPC (5.6 mg) and  $^3\text{H}$ -triolein (80  $\mu\text{Ci}$ ), that was dried under nitrogen and recovered in 2 ml of TBS, followed by extensive sonication.

*Phospholipid transfer assay:*

PLTP-specific phospholipid transfer activity was determined by the radiolabeled liposome to HDL<sub>3</sub> transfer assay described (Damen et al. 1982), but the incubation was extended from 30 to 60 minutes. Samples were incubated with PC vesicles and HDL<sub>3</sub>, followed by the selective precipitation of the vesicles using a heparin/manganese solution.  $^{14}\text{C}$  in the supernatant represents phospholipid transferred from the liposomes to HDL<sub>3</sub>. Blank counts represent spontaneous transfer without an exogenous source of PLTP, and this was subtracted from the counts in each sample. The counts transferred to

the HDL<sub>3</sub> fraction were expressed as percent of the total counts present, and this value is referred to as PL transfer activity.

#### *Neutral Lipid Transfer Assays*

To assay the CE transfer activity of each mutant relative to wildtype CETP, the method of Wang et al (1991) was followed with some modifications. Media samples of 25–100 µl were assayed, and the total volume of media in each reaction was made up to 100 µl with mock transfection media. The sample was incubated with <sup>3</sup>H-CE-HDL (2 µg of cholesterol) and LDL (20 µg of cholesterol), in a total volume of 500 µL TSE (50 mM Tris, 150 mM NaCl, 0.05 % (w/v) sodium azide, 1 mM EDTA, pH 7.4) in a shaking water bath at 37°C for 3 hours. Blank and total count tubes were also prepared, in which TSE was substituted for sample. The reaction was stopped on ice and by adding 450 µl of TSE containing 50 µg of LDL protein to aid precipitation. This was followed by the addition of 350 µl of precipitation buffer composed of 4 parts 20% BSA (w/v), 1 part 2 M MnCl<sub>2</sub>, and 1 part 10,000 units/mL heparin. To total count tubes, 350 µl TSE was added instead of the precipitation solution. LDL was precipitated on ice for 10 minutes, followed by centrifugation in a microfuge at 12,000g for 15 minutes. One ml of supernatant was transferred to a scintillation vial, mixed with 2ml of scintillation fluid, and <sup>3</sup>H remaining in the supernatant HDL fraction was counted for 10 minutes. The blank counts represent spontaneous transfer without an exogenous source of CETP, and this was subtracted from the counts in each sample. The counts transferred to the LDL fraction were expressed as percent of the total counts present, and this is referred to as CE transfer activity.

The triglyceride transfer of each construct was assayed in the same manner as described for the CE transfer, with the following changes. Samples were incubated with  $^3\text{H-TG-LDL}$  (20  $\mu\text{g}$  cholesterol) and HDL (40  $\mu\text{g}$  cholesterol). The reaction was left at 37°C for 18 hours before precipitation of LDL. In this case, counts in the supernatant represent counts transferred to the acceptor HDL particle. Again, blank counts were subtracted from each sample, and the counts transferred to HDL were expressed as a fraction of the total counts, referred to as TG transfer activity.

### **Data analysis and statistics**

The same analysis was applied to data from each of the PL, CE, and TG transfer activity assays. The activity in the mock transfection media was subtracted from each sample, and any negative activity values were set at zero. To determine the specific activity (SA) in each sample, the activity was divided by the relative amount of immunoreactive protein present. Specific PL transfer activity was determined based on the relative amount of PLTP present, and specific CE and TG activity were determined based on the relative amount of CETP present. The mean SA was determined for the wildtype protein in each experiment. Then, each sample SA was divided by the mean wildtype SA to determine the relative SA. Each experiment was repeated 3 times with 10 to 15 samples of each type per experiment. The mean relative SA was determined for each construct by pooling all of the values from the 3 independent experiments, and are expressed  $\pm$  standard error of the mean (SEM). An analysis of variance (ANOVA) was performed to demonstrate that there is no significant difference between the results of the

3 separate experiments in each case. Two-sample t-tests were used to compare the pooled data for each chimeric protein relative to the wildtype.

### **Antibody production**

#### *Materials:*

Nickel-triacetic acid (Ni-NTA) resin was from Qiagen. Chinese Hamster Ovary (CHO) cells and the Sp2/0 myeloma cells were from ATCC. The serum-free media Hy-Q CCM5 was from Cedarlane Laboratories. The plasmid expressing GMCSF was provided by Dr. L. Chan (Baylor College of Medicine, Houston, Texas).

#### *Protein Purification*

Recombinant human PLTP with an N-terminal hexaHIS tag was expressed in *E.coli* using the plasmid PLTP-HIS-pTRCHIS, and purified by Nickel chelate affinity chromatography under denaturing, reducing conditions. Briefly, bacteria were lysed (6 M guanidine HCl, 20 mM sodium phosphate, 500 mM NaCl, pH 7.8, plus 1%  $\beta$ -mercaptoethanol) and incubated with Ni-NTA resin for 1 to 2 hours at 4°C. Solutions for chromatography contained 8 M urea, 20 mM sodium phosphate, 500 mM NaCl, and 0.1%  $\beta$ -mercaptoethanol. Nonspecific proteins were removed by washes at pH 7.8, 6.0, and 5.3, and HIS-PLTP was eluted at pH 4.0. The concentration and purity of the HIS-PLTP was estimated by running a sample on SDS-PAGE and immunoblotting with the anti-HIS mAb or staining with Coomassie Blue. The protein was dialysed against PBS, and the insoluble fraction was used for immunization.

Recombinant human PLTP with a C-terminal hexaHIS tag was stably expressed in CHO cells and purified from serum-free media by Nickel chelate affinity chromatography under native conditions. Media was collected 24 to 48 hours after the cells had reached confluence, and concentrated in 30 kDa molecular weight cutoff concentrators (Amicon). Solutions for chromatography contained 50 mM sodium phosphate and 300 mM NaCl. The media was passed over the Ni-NTA resin twice, washed at pH 7.6 and 6.0, and PLTP-HIS was eluted at pH 4.0. The concentration and purity of the PLTP-HIS was estimated by running a sample on SDS-PAGE and immunoblotting with the anti-HIS mAb or staining with Coomassie Blue.

#### *Protein Immunization*

Approximately 15  $\mu\text{g}$  of bacterially expressed protein in 250  $\mu\text{l}$  PBS and emulsified in complete Freund's adjuvant was used to immunize female Balb/c mice intraperitoneally. Two additional boosts were given of the same antigen in incomplete Freund's adjuvant, at 2 to 3 week intervals. Approximately one year after the initial immunization, the mice were given a final intravenous boost of approximately 25  $\mu\text{g}$  of the native protein in PBS. Three or four days following the final boost, the spleen was harvested and cells were fused with Sp2/0 myeloma cells according to the method of Milne et al. (1992). Hybridomas were screened by ELISA for reactivity with bacterially expressed PLTP, and positive clones were subcloned and expanded. Cells from one positive subclone were used to produce ascites and purified IgG that was used for further testing by ELISA and Western blot.

### *DNA Immunization*

Female Balb/c mice were injected four times at intervals greater than 2 weeks, intradermally with plasmid DNA in PBS. The first two injections were of 25 µg of the plasmid PLTP-HIS-pcDNA, which expresses human PLTP with c-myc and hexaHIS epitopes at the C-terminal. For the third and fourth injections, the mice were also given 25 µg of the plasmid GMCSF-pCMV1, which expresses granulocyte macrophage colony stimulating factor (GMCSF). As a negative control, mice were injected on the same schedule with 25 µg each of the empty plasmid pcDNA3.1, and the GMCSF expression vector. The mice were bled 1 week following each injection, and serum was tested for reactivity on ELISA with bacterial and native PLTP. Three or four days following the fourth boost, the spleen was harvested for fusion with Sp2/0 myeloma cells in order to produce hybridomas. Hybridomas were screened on ELISA for reactivity with native human PLTP expressed in CHO cells, and positive clones were subcloned, expanded, and used for further testing on ELISA and Western blot. Sp2/0 cells were injected directly into the peritoneal cavity of one immunized mouse in order to induce tumor formation and ascites production (Milne et al. 1992).

In a second DNA immunization experiment, female Balb/c mice were injected 3 times intradermally and once intramuscularly with 25 µg each of the PLTP and GMCSF expression plasmids, at intervals of greater than 2 weeks. Control mice were injected on the same schedule with 25 µg each of the empty plasmid pcDNA3.1, and the GMCSF expression vector. The mice were bled 1 week following each injection, and serum was tested for reactivity on ELISA and Western blot with bacterial and native PLTP. A final intravenous boost was given with native PLTP protein purified from CHO cell media, 4

days before fusion. Hybridomas were screened by ELISA for reactivity with bacterially expressed PLTP.

## Chapter III: Results

### Expression of Proteins in COS-7 Cells

DNA encoding wild type PLTP (PLTP<sub>1-476</sub>-myc-HIS-pCMV5), wild type CETP (CETP<sub>1-476</sub>-pCMV5), and three C-terminal chimeric proteins of PLTP and CETP (PLTP<sub>1-444</sub>/CETP<sub>461-476</sub>-pCMV5 ('PC'), CETP<sub>1-460</sub>/PLTP<sub>445-476</sub>-pCMV5 ('CP'), and CETP<sub>1-460</sub>/PLTP<sub>445-476</sub>-mycHIS-pCMV5 ('CP-HIS')), in the expression vector pCMV5, were transiently transfected into COS-7 cells. The proteins could all be detected by Western blotting of cell lysate and serum-free media 72 hours post-transfection. CETP was detected by all of the CETP mAbs tested (TP1, TP2, TP4, TP24, TP11, TP14, TP15, and TP20), and PLTP was detected by the anti-HIS and 9E10 (anti-myc) antibodies. The PC chimera could be detected with the CETP C-terminal mAbs TP1, TP2, TP4, and TP24. The CP chimera could be detected with the CETP central domain mAbs TP11, TP14, TP15, and TP20, and CPHIS could be detected with the same mAbs as the CP, as well as the anti-HIS and anti-myc mAbs. Some typical Western blots are shown in figure 13.

The chimeric proteins appeared to be produced and secreted at levels comparable to the wild type proteins. The sizes of both the cellular and secreted forms of each protein were as expected based on the number of amino acids, and predicted glycosylation sites in each molecule. The intracellular form of CETP has a predicted mass of 58 kDa, and the CP chimera should be about 2 kDa larger than the wildtype CETP. The addition of the hexa-HIS and c-myc epitopes to the CP construct adds an additional 3 kDa of molecular weight. These differences are visible on Western blot. Similarly, the PC construct is expected to be about 2 kDa smaller than the wildtype

**Figure 13. Expression of PLTP, CETP, and chimeric proteins in COS-7 cells.**

Cells were transiently transfected with the various constructs, and 72 hours post-transfection, cell lysate (c) and TCA precipitated media (m) were run on SDS-PAGE under reducing conditions. Immunoblotting was with **A)** anti-HIS, **B)** TP20, or **C)** TP1. 'Mock' refers cell lysate and media from cells transfected with the empty plasmid pCMV5. Molecular weight markers are indicated on the left.

**A**

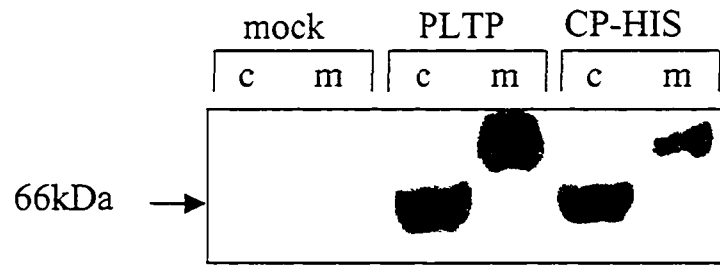

**B**

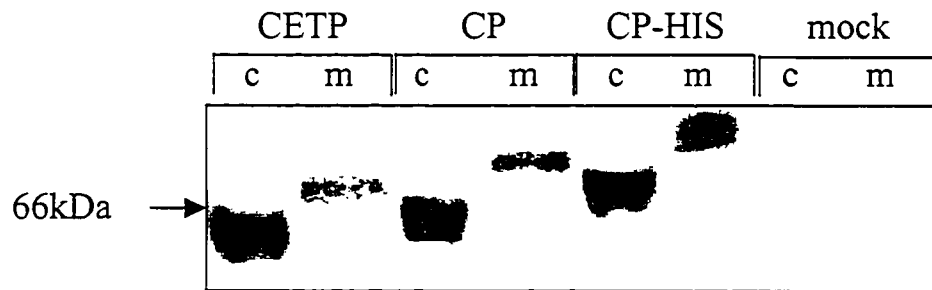

**C**

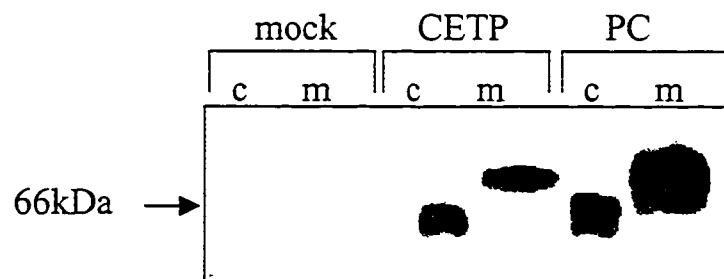

CETP, although this difference is less obvious on Western blot. The intracellular form of the PLTP-HIS is predicted to be about 60 kDa, and the CPHIS construct appears slightly larger on Western blot. The mature form of each protein is visible in the media, and are about 5 to 20 kDa larger than the cellular form, due to post-translational modifications. Often the bands in the media were spread over a range of sizes, probably due to variable glycosylation of the proteins. There are no sites for N-glycosylation in the exchanged regions of CETP or PLTP, so the degree of glycosylation should be the same as the parent protein. Successful secretion of the chimeras indicates that the overall protein folding and post-translational modifications were not disturbed. As the epitopes of the anti-HIS, anti-myc, and CETP C-terminal mAbs are located at the extreme C-termini of the proteins, reactivity of the constructs with these antibodies indicates the presence of full length protein in each case.

The construct 'PGGC' was never detected on Western blot in either cell lysate or media with any of the CETP C-terminal tail antibodies tested (TP1, TP2, TP4, or TP24). However, it is not possible to say whether this is because of a loss of the epitope, or a lack of recombinant protein.

### **Relative Quantification of Immunoreactive Protein**

Once the presence of each protein in the transfection media was demonstrated by Western blot, relative amounts were quantified on slot blots. PLTP and CPHIS were compared using the anti-myc mAb 9E10, CETP and PC were compared with TP24, and CETP, CP, and CPHIS were compared using TP11. Application of increasing amounts of media gave a linear increase in the densitometry signal, with  $R^2 = 0.75$  in all cases.

Application of mock transfected media consistently gave densitometry readings comparable to those for PBS alone, for each of the three antibodies used. The linear regression lines for each sample type on any given slot blot were shown to be approximately parallel, and densitometry signals for each sample type were generally within a similar range for each blot. Figure 14 shows a typical slot blot for each antibody, and the corresponding plots of densitometry signal versus amount of media applied.

### **Lipid Transfer Activities of Wildtype and Chimeric Proteins**

#### *PLTP-specific Phospholipid Transfer Activity*

Various amounts of transfected COS-7 cell media containing wildtype PLTP, wildtype CETP, or the chimeric proteins CP and CPHIS were assayed for the ability to transfer radiolabelled phospholipid from phosphatidylcholine vesicles to HDL<sub>3</sub>. In each of three independent experiments, the PL transfer activity in media containing PLTP increased linearly with the amount of PLTP protein assayed. However, as the amount of CETP, CP, or CPHIS protein was increased, the PL transfer activity did not increase. The results of one experiment are shown as representative results of the 3 independent experiments (Figure 15A). The transfer activity per relative units of PLTP protein (“specific activity”) was calculated for each sample in each experiment. Based on pooled data from the three independent experiments, the specific activity of CETP, CP, and CPHIS, were all found to be less than 10% of the specific activity of wildtype PLTP, with  $p < 0.0001$  in a Student’s t-test (Figure 15B). These results confirm that as expected, wildtype CETP does not show any PL transfer activity in this type of *in vitro* assay. The

**Figure 14. Relative Quantification of Immunoreactive Protein by Slot Blot.**

Various amounts of media from COS-7 cells transiently transfected with wildtype or chimeric proteins were applied to nitrocellulose membrane using a slot blot apparatus. At the top right of each panel is a typical slot blot, for each primary antibody used: **A)** TP24; **B)** TP11; **C)** 9E10. The densitometry signal (area x intensity) versus amount of media applied was plotted, and a linear regression line generated for each construct on each blot.

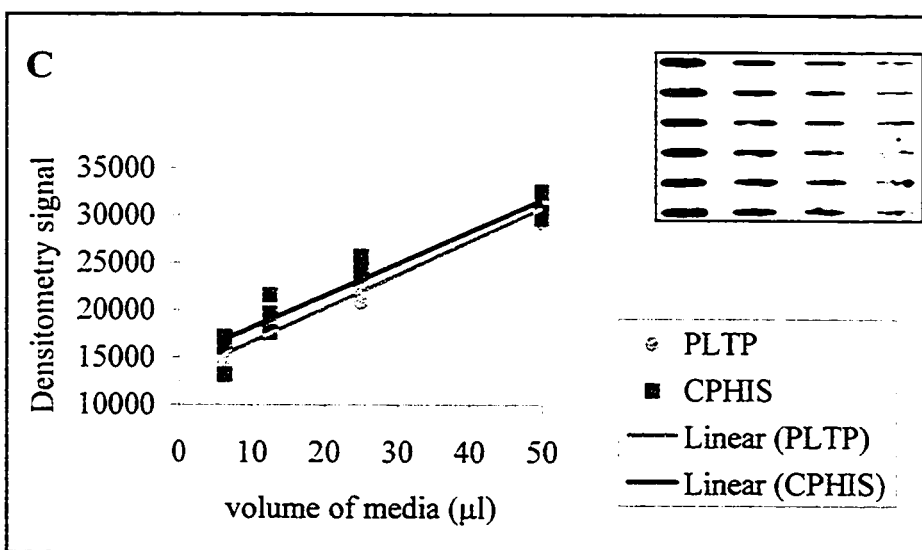
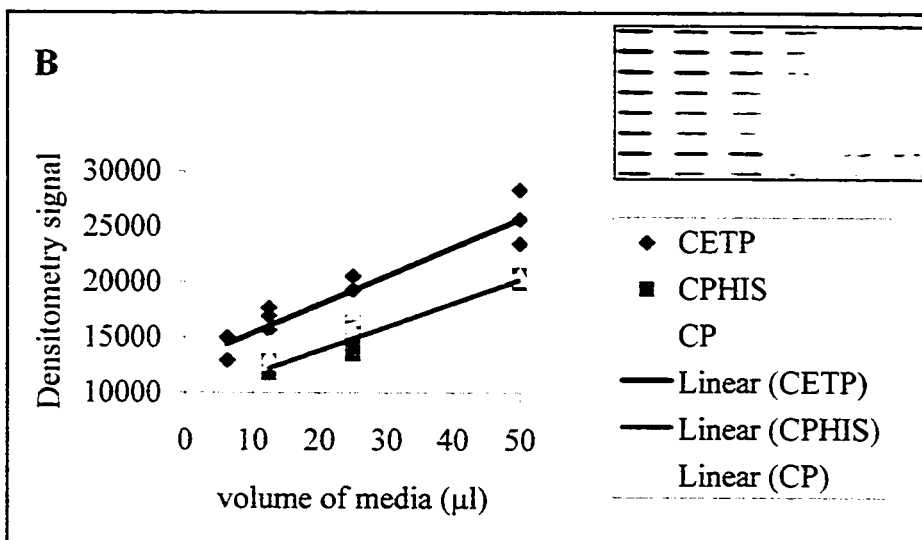
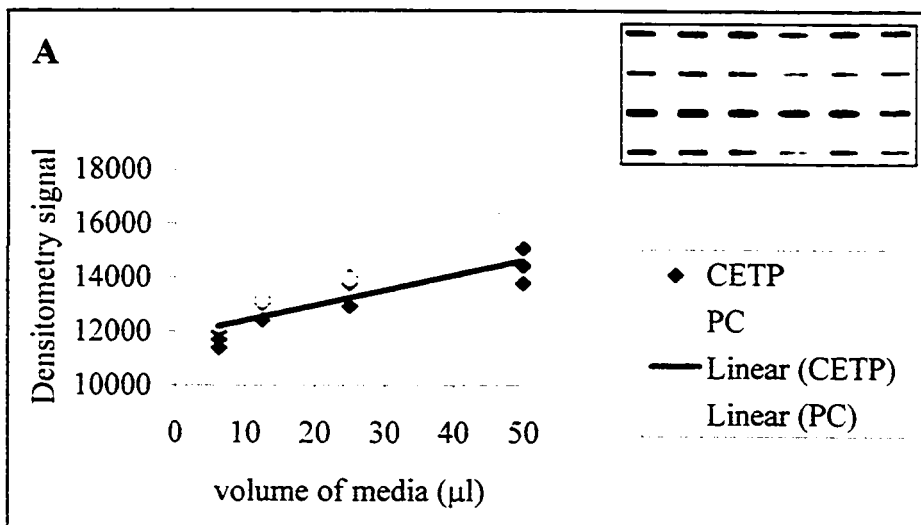
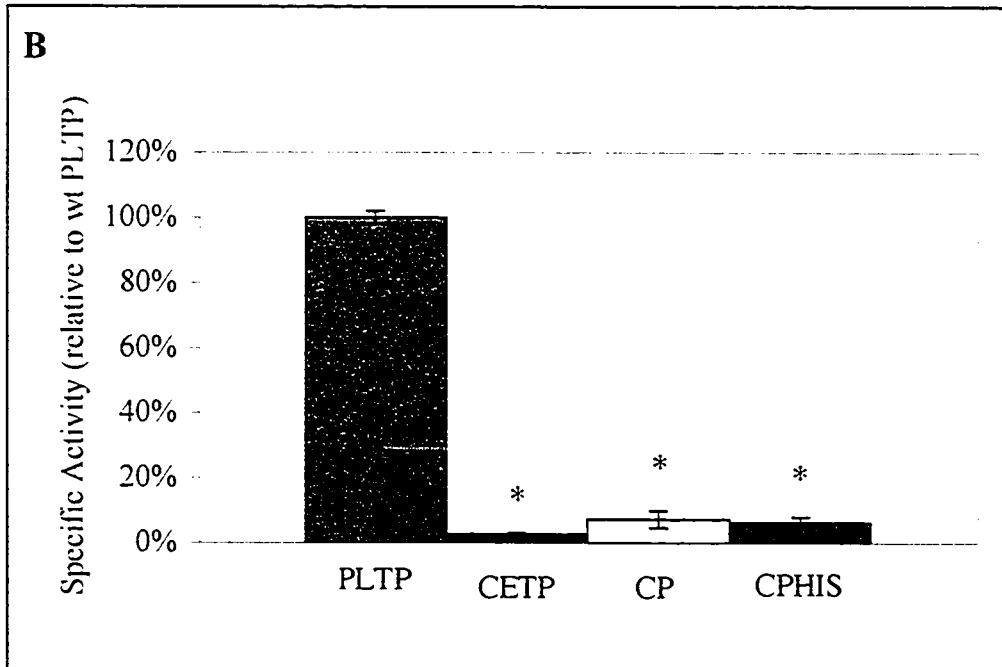
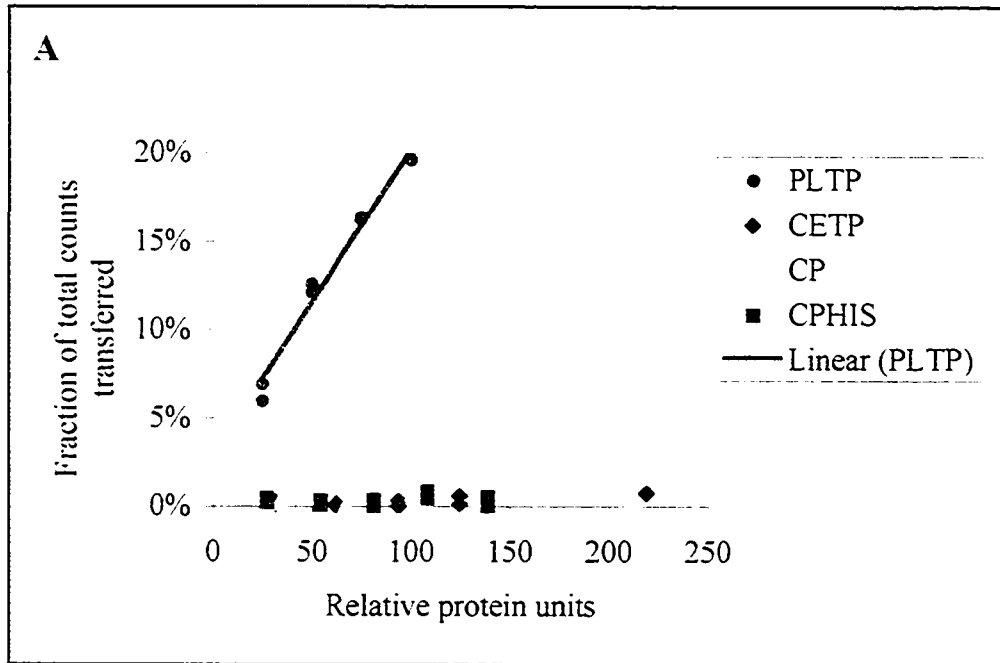

**Figure 15. Phospholipid transfer activity of PLTP, CETP, and chimeric proteins.**

Transfer of  $^{14}\text{C}$ -PC from liposomes to HDL<sub>3</sub> was measured in the media from COS-7 cells 72 hours post-transfection. The relative amounts of CPHIS and PLTP protein were determined by slot-blotting with 9E10 (anti-myc), and the relative amounts of CPHIS, CP, and CETP protein were determined by slot-blotting with TP11.

**A)** The results from one PL transfer assay, as representative of three independent experiments. The fraction of the total radioactivity transferred in 1 hour is plotted against the relative amount of immunoreactive protein present.

**B)** The specific activity for each construct was calculated by dividing the fraction of the total radioactivity transferred by the amount of immunoreactive protein present. The results are expressed as percentages of the wildtype PLTP, and are shown as the mean values  $\pm$  SEM, using pooled data from three independent experiments. \* In two-sample t-tests,  $p < 0.0001$  compared to wildtype PLTP activity.



lack of PL transfer activity of the chimeras CP and CPHIS indicates that the replacement of the C-terminal tail of CETP with that of PLTP is not sufficient to confer PLTP-like PL transfer activity to CETP. Without an antibody that would react with both PLTP and the PC chimera, the relative amounts of these proteins could not be compared, and therefore the PL transfer activity of the PC was not determined.

#### *Neutral Lipid Transfer Activity*

Secreted protein was also assayed for the ability to transfer the neutral lipids cholesteryl ester and triglyceride between lipoproteins. In each of three independent CE transfer experiments, the amount of CE transferred from HDL to LDL in media samples containing CETP increased linearly with the volume of media assayed. In contrast, as the volume of media containing PLTP, PC, CP, or CPHIS assayed was increased, there was no increase in activity. This is illustrated by one representative experiment (Figure 16A). The CE transfer activity per relative units of CETP protein (“specific activity”) was calculated for each sample in each experiment. Based on pooled data from the three independent experiments, the specific activity of PLTP, PC, CP, and CPHIS, were all found to be less than 10% of the specific activity of wildtype CETP, with  $p < 0.0001$  in Student’s t-test (Figure 16B).

Similar results were obtained in TG transfer experiments: in each of three independent experiments, the amount of TG transferred from LDL to HDL in media samples containing CETP increased linearly with the volume of media assayed. In contrast, as the volume of media containing PLTP, PC, CP, or CPHIS assayed was increased, there was no increase in activity. The results of one experiment are shown as

**Figure 16. Cholesteryl Ester transfer activity of CETP, PLTP, and chimeric proteins.**

Transfer of  $^3\text{H}$ -CE from HDL to LDL was measured in the media from COS-7 cells 72 hours post-transfection. The relative amounts of CETP, CP, and CPHIS protein were determined by slot-blotting with TP11, the relative amounts of CPHIS and PLTP protein were determined by slot-blotting with 9E10 (anti-myc), and the relative amounts of CETP and PC protein were determined by slot-blotting with TP24.

- A)** The results from one CE transfer assay, as representative of three independent experiments. The fraction of the total radioactivity transferred in 3 hours is plotted against the relative amount of each protein present.
- B)** The specific activity for each construct was calculated by dividing the fraction of the total radioactivity transferred by the amount of protein present. The results are expressed as percentages of the wildtype CETP, and are shown as the mean values  $\pm$  SEM, from data pooled from three independent experiments. \* In two-sample t-tests,  $p < 0.0001$  compared to wildtype CETP activity.

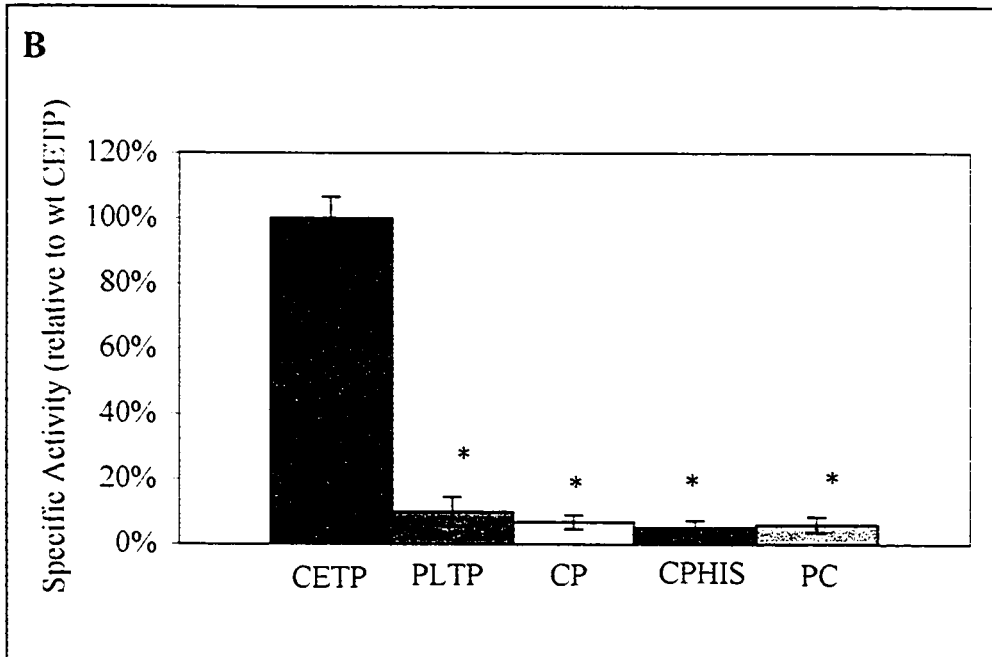
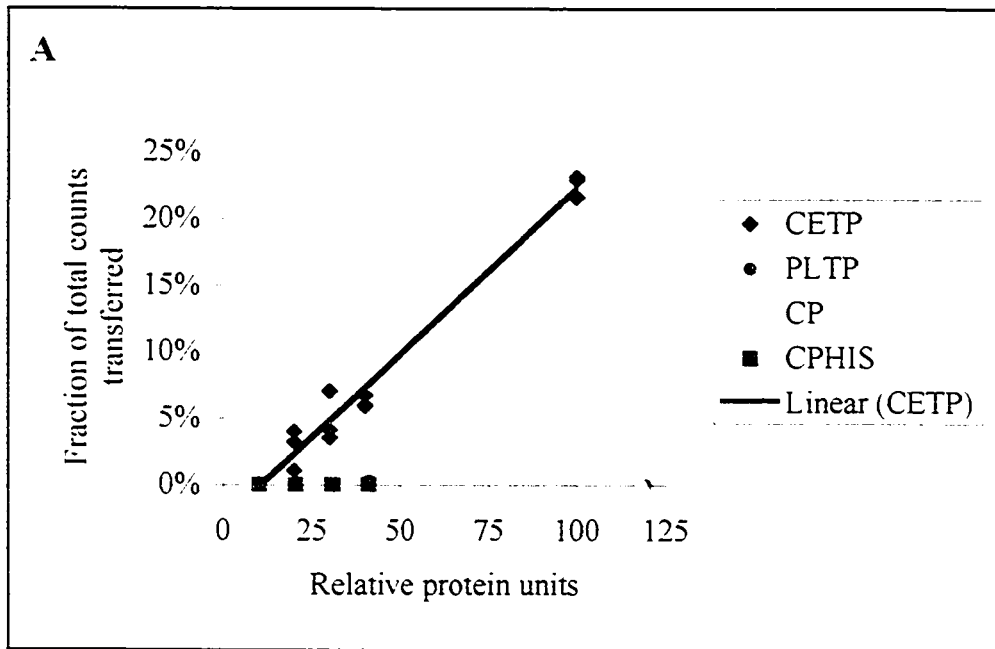

representative of the three independent experiments (Figure 17A). The TG transfer activity per relative units of CETP protein (“specific activity”) was calculated for each sample in each experiment. Based on pooled data from the three independent experiments, the specific activity of PLTP, PC, CP, and CPHIS, were all found to be less than 5% of the specific activity of wildtype CETP, with  $p < 0.001$  in a Student’s t-test (Figure 17B).

The results of the CE and TG transfer assays confirm that the wildtype PLTP does not transfer neutral lipids. Second, they demonstrate that when the C-terminal helix of CETP is replaced by the C-terminal of PLTP, the neutral lipid transfer activity of CETP is not retained. Third, they show that replacement of the PLTP C-terminal with the C-terminal tail of CETP is not sufficient to impart CE or TG transfer activity to PLTP.

## **Antibody production**

### *Protein Purification*

Recombinant HIS-PLTP was expressed in *E.coli* and purified on Ni-NTA under denaturing, reducing conditions. When the column eluate was run on SDS-PAGE, and immunoblotted using the mAb to the hexahis epitope, a single band at 58kDa was detected. By staining all of the proteins in the eluate with Coomassie Blue, impurities of various sizes were detected, although the band at 58kDa appeared to be the major component. When fractions containing PLTP were pooled and dialysed against PBS, the protein formed an insoluble aggregate.

PLTP was also expressed in a stable CHO cell line, and secreted protein was purified under native conditions. The protein was run on SDS-PAGE, and using

**Figure 17. Triglyceride transfer activity of CETP, PLTP, and chimeric proteins.**

Transfer of  $^3\text{H}$ -TG from LDL to HDL was measured in the media from COS-7 cells 72 hours post-transfection. The relative amounts of CETP, CP, and CPHIS protein were determined by slot-blotting with TP11, the relative amounts of CPHIS and PLTP protein were determined by slot-blotting with 9E10 (anti-myc), and the relative amounts of CETP and PC protein were determined by slot-blotting with TP24.

**A)** The results from one TG transfer assay, as representative of three independent experiments. The fraction of the total radioactivity transferred in 18 hours is plotted against the relative amount of each protein present.

**B)** The specific activity for each construct was calculated by dividing the fraction of the total radioactivity transferred by the amount of protein present. The results are expressed as percentages of the wildtype CETP, and are shown as the mean values  $\pm$  SEM, from data pooled from all independent experiments. For CP, CPHIS, and PC,  $n=3$ ; for PLTP  $n=2$ . \* In two-sample t-tests,  $p<0.0001$  compared to wildtype CETP activity. \*\* In two-sample t-test,  $p<0.001$  compared to wildtype CETP activity.

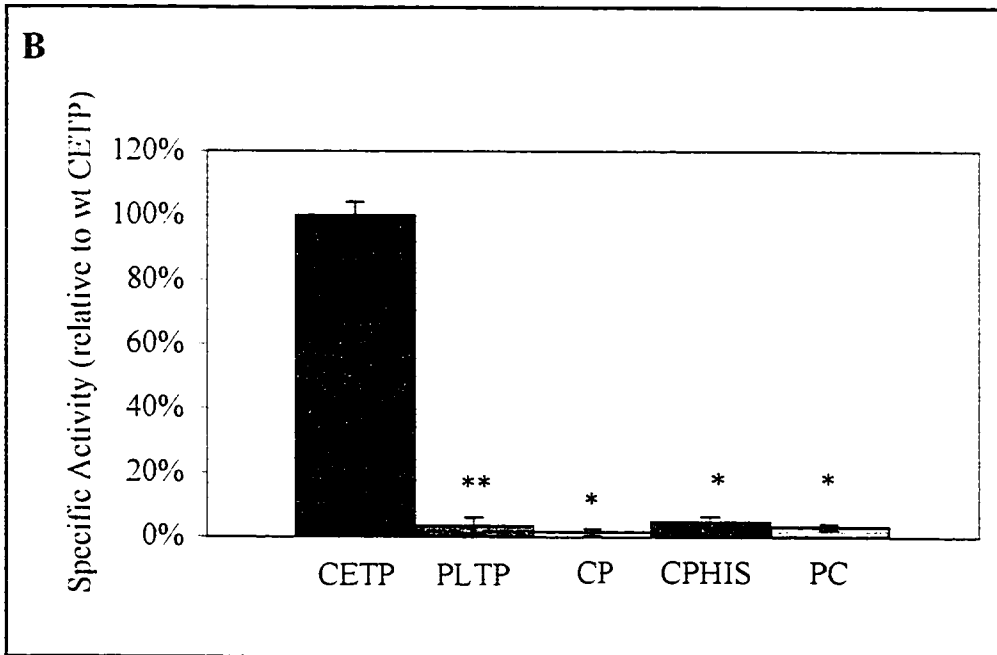
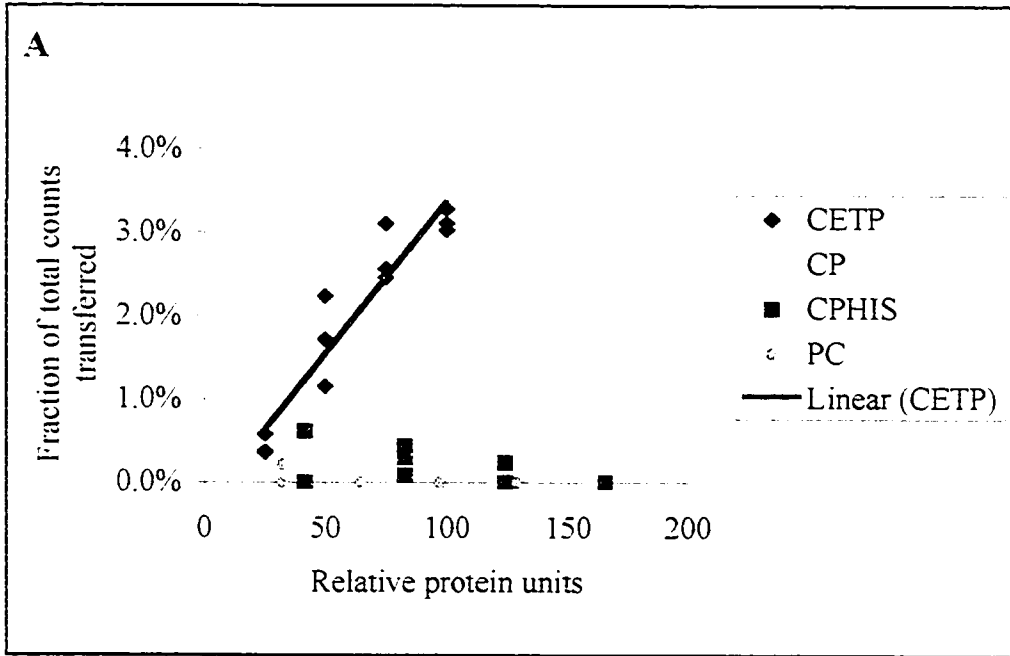

antibodies to either the c-myc or the hexahis epitopes, a single band at about 90kDa was detected on immunoblot. Using Coomassie Blue stain, impurities of various sizes were detected.

### *Protein Immunization*

Mice were given three injections of denatured, recombinant PLTP purified from *E.coli*, followed by a final boost of native recombinant PLTP purified from CHO cell media, as described under 'Materials and Methods'. After the three injections with bacterially expressed PLTP, serum from two of the mice reacted on ELISA, and pooled sera from five mice reacted on a Western blot under reducing conditions (not shown). Fusions from two mice produced one hybridoma clone that initially reacted with the bacterial recombinant PLTP on ELISA. However, on subsequent ELISAs, this hybridoma appeared to react with nonspecific proteins. Further, the ascites and IgG produced from this clone did not react on ELISA or Western blot with either the bacterial or mammalian form of recombinant PLTP.

### *DNA Immunization*

Mice were immunized intradermally with plasmid DNA encoding full-length human PLTP, as described under 'Materials and Methods'. After three injections, two mice had serum antibodies against both the bacterial and the mammalian forms of the recombinant protein, as shown by ELISA (Figures 18A and 18B). In addition, serum from one of these mice reacted strongly and specifically on a Western blot against COS cells and media expressing PLTP, and PLTP purified from CHO cell media (Figure 18C).

The same serum did not react on Western blot with other HIS-tagged proteins. Fusions from the two mice with the highest titre on ELISA resulted in some hybridoma clones that were initially positive on an ELISA screen against native PLTP, but all of these clones either became unreactive during subcloning and growth, or were found to be reacting with non-specific proteins.

**Figure 18. Screening of mouse sera for anti-human PLTP antibodies.**

Mice were bled 1 week after three intradermal injections with the human PLTP expression plasmid PLTP-HIS-pcDNA. ELISAs were performed against both **A)** denatured, bacterially expressed PLTP, and **B)** native PLTP purified from CHO cell media. **C)** Serum from mouse 3 was used on a Western blot against 1) cell lysate and 2) media from COS-7 cells transiently transfected with PLTP-pCMV5 DNA, and 3) PLTP purified from CHO media.

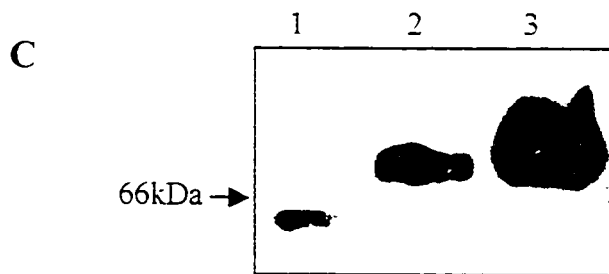
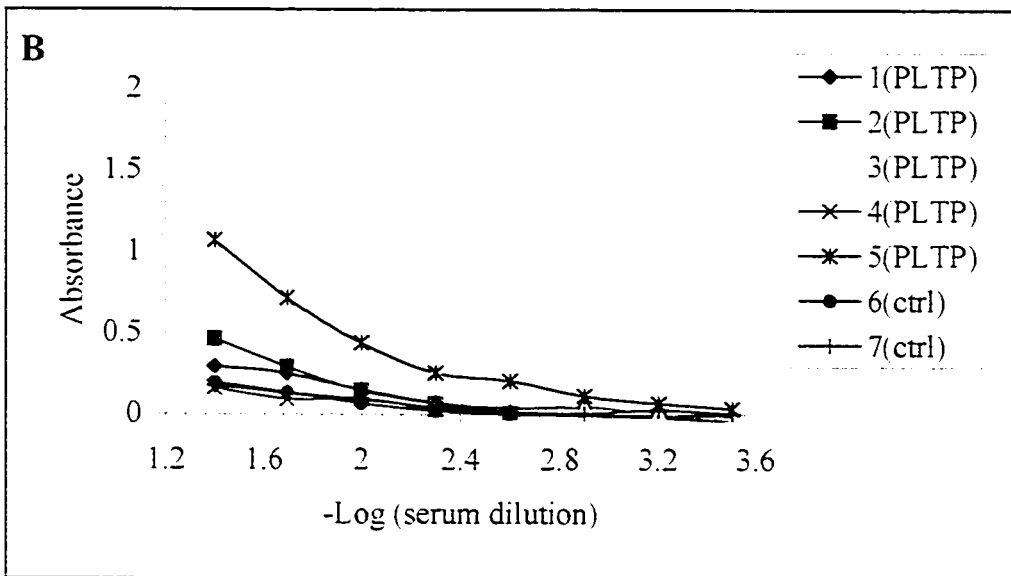
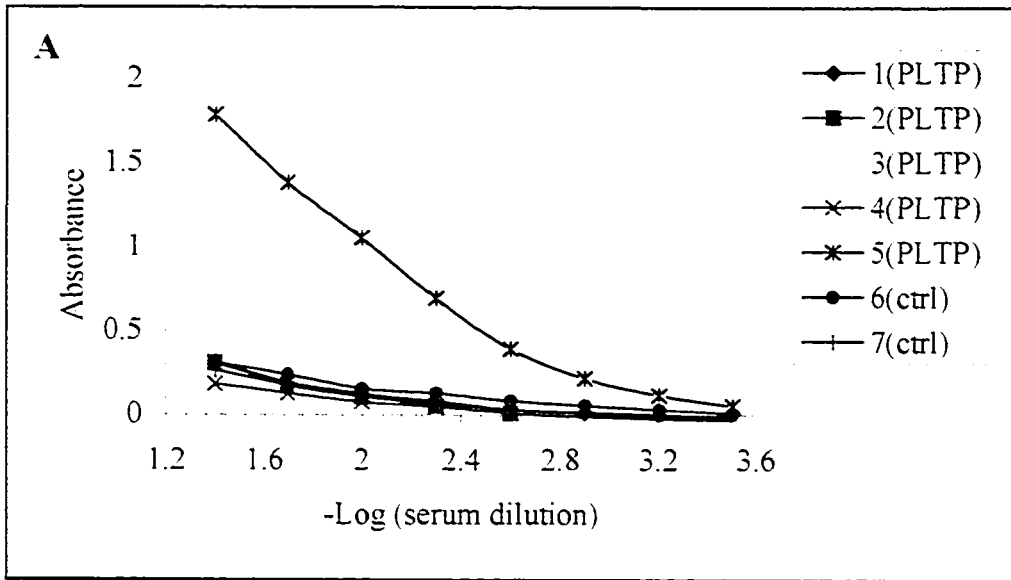

## Chapter IV: Discussion

### Design and Expression of Chimeric Proteins

In this study, we expressed C-terminal tail chimeras of PLTP and CETP in order to investigate whether this region determines the lipid transfer specificity of each protein. Deletion mutants and site-directed mutagenesis had previously implicated this region as critical for the function of both CETP and PLTP. In the case of CETP, neutral lipid transfer activity is significantly reduced by mutation of specific bulky, hydrophobic residues, particularly leucines and phenylalanines, near the carboxy terminus, and by deletion of residues 470 to 475 (Wang et al. 1993, Wang et al. 1992). Similarly, the phospholipid transfer activity of PLTP is reduced to less than 40% of the wildtype PLTP by deletion of residues 457 to 476, and is abolished by deletion of residues 447 to 476 (Huuskonen et al. 1998). Our approach was to interchange a small section at the carboxy terminus of each protein with the corresponding region of the other. Thus we could ascertain which properties of the parent proteins are retained, and whether any properties are gained via the exchanged regions.

Our chimeras were designed based on 3-D models of PLTP and CETP tertiary structure that had been developed from BPI tertiary structure information. As we were working from two separate models rather than a known protein structure, we can not conclude for certain whether the tail regions of the chimeras would be situated in a position equivalent to where they lie in the native proteins. However, this is a shortcoming of all modeling and structural studies, and we must make do with these models until we are able to directly solve the structures of PLTP or CETP.

The region of the CETP C-terminal tail that we chose to exchange with PLTP included residues 465 to 476, which have been proposed to form an amphipathic alpha-helix (Wang et al. 1993). These residues in particular had been previously demonstrated to be important for both neutral lipid transfer and TP2 binding (Wang et al. 1992). We also included residues 461 to 464 as a 'linker' region to ensure sufficient flexibility of the helix in the chimeric molecule. Based on a sequence alignment of mature PLTP and CETP, we replaced the equivalent 32 residues of PLTP with these 16 residues of CETP, and vice-versa.

Some studies with C-terminal deletion mutants of CETP and PLTP have suggested that residues near the carboxy termini may be required for folding and secretion of the mature proteins. In the case of CETP, the deletion mutant  $\Delta 465-475$  was secreted from transfected COS-7 cells, but the mutants  $\Delta 463-469$ ,  $\Delta 457-462$ , and  $\Delta 451-456$  were not secreted (Wang, et al. 1992), suggesting that removal of more than 12 residues from the C-terminus of CETP results in a misfolded protein. Similarly, the PLTP deletion mutant  $\Delta 447-476$  is secreted, but  $\Delta 442-476$  is not, suggesting that removal of more than 30 residues from the C-terminus of PLTP results in misfolded protein (Huuskonen et al. 1998). We were hoping, therefore, that we could make chimeric proteins by exchanging the two carboxy-terminal sequences directly, while leaving the overall folding of the proteins undisturbed.

Previous studies have also shown that recombinant PLTP with a hexaHIS tag at the C-terminus is secreted from cultured cells and is active (Albers et al. 1995). Our results confirm this, as the wildtype PLTP with C-terminal hexaHIS and c-myc tags expressed in COS-7 cells was secreted and active. However, we decided to make the

'CP' construct both with and without the epitope tags, to be certain that in the context of the chimeric protein, the extra amino acids do not interfere with folding or activity. The addition of the hexaHIS and c-myc epitopes also had the advantage of enabling us to detect and quantify the CPHIS protein relative to the wildtype PLTP, using the anti-HIS or anti-myc antibodies.

Since the chimeric proteins CP, CPHIS, and PC were efficiently secreted from transfected COS-7 cells, it appears that the loss of amino acids at the carboxy-terminus of one protein can be compensated for by the addition of residues from the other, at least in terms of protein folding and secretion. Thus we can conclude that any defects in activity are due to the specific sequences at the C-terminal and not to a globally misfolded protein.

### **Method Development and Validation**

One of the hurdles for completion of this project was the quantification of proteins in the media from transfected cells. Part of this problem was related to the availability of suitable antibodies: as we are using chimeric proteins, each construct contains different antibody epitopes, and therefore we could not use a single antibody to compare all of the constructs. For example, a radioimmunoassay (RIA) has been developed for the determination of the amount of CETP protein in a sample, relative to a standard (Marcel et al. 1990). However, this assay uses TP2, and therefore could only be used for those constructs expressing the TP2 epitope. Second, because of the lack of a 'standard' of known CETP or PLTP concentration, we could only determine relative protein concentrations, instead of absolute values. The third limitation was that relatively

small quantities of protein were present in the media. In previous studies, one way of getting around this problem was the use of acetone to precipitate all of the media from at least one 10 cm dish to quantify protein, which would mean larger-scale transfections. We chose instead to develop a slot blot method for determining the relative amounts of wildtype and chimeric proteins in the media samples.

Once the conditions for the slot blots were optimized, we were able to obtain consistent, reliable data for the relative amounts of PLTP, CETP, or chimeric protein in a given media sample. As described under 'materials and methods', for PLTP activity assays, we expressed each protein concentration relative to wildtype PLTP, and for CETP activity assays, we expressed each protein concentration relative to wildtype CETP. One drawback to this method is that two separate blots were required to compare some of the constructs. For example, in order to compare wildtype PLTP with the construct 'CP', we first had to compare PLTP with CPHIS on a 9E10 (anti c-myc) slot blot, and then compare CPHIS with CP on a TP11 slot blot. However, we simply considered this to be using a 'secondary standard', which would have been required for other quantification methods also. In circumstances where plotting the densitometry values against the volume of media applied did not give a  $R^2$  value of greater than 0.75 for every construct, the slot blot was repeated. Generally, the relative protein concentrations were determined from a single slot blot, but four dilutions of each sample were applied, each in triplicate, for a total of twelve data points. We found this method to be reliable and accurate.

The measurements of neutral lipid transfer activity also required some development. Published methods for the radiolabeled CE transfer assay often suggested incubating a given number of counts from  $^3\text{H}$ -CE-HDL, and a given amount of protein

from the LDL as the CE acceptor. We adapted this method such that a consistent amount of cholesterol from the donor and acceptor was present, regardless of the number of counts. This way, we could ensure an excess of acceptor cholesterol, and therefore minimize back-transfer of radiolabeled CE. We also found that results were inconsistent if we did not add the same volume of media into each reaction; therefore every sample in our assays was made up to a total of 100  $\mu$ l with mock transfection media. The time of incubation varies among publications, and we chose a 3 hour incubation as that was usually sufficient time for 100  $\mu$ l of media containing CETP to transfer up to 25% of the total counts from HDL to LDL. The published linear range of CE transfer assays is about 20-30% of the total counts transferred (Glenn and Melton 1995).

In terms of the TG transfer assays, most published methods used  $^3\text{H}$ -CE and  $^{14}\text{C}$ -TG double-labeled HDL. However, our equipment is not capable of differentiating between the two types of radioactivity, so a single-label experiment was designed, based on the CE-transfer assay we had already set up. In preliminary experiments,  $^3\text{H}$ -TG-labelled HDL was isolated, but it seemed to be unstable, so we instead isolated  $^3\text{H}$ -TG-labelled LDL, and used HDL as the acceptor. The transfer of TG is much less efficient than that of CE (Ohnishi et al. 1994), so the incubation was left for 18 hours, which did not increase the background transfer.

Before testing the activities of the chimeras, we tested the wildtype PLTP and wildtype CETP for PL, CE, and TG transfer. As expected, PLTP could transfer PL from vesicles to HDL<sub>3</sub>, but had no neutral lipid transfer activity. In contrast, CETP could transfer neutral lipids between HDL and LDL, but could not transfer PL from vesicles to HDL<sub>3</sub>.

## **Lipid Transfer Activities of Chimeric Proteins, and Structural Implications**

Initially, we thought that the addition of the C-terminal helix of CETP would be sufficient to impart neutral lipid transfer activity to PLTP. This seemed like a reasonable proposal since there is not yet any evidence supporting a model in which the ligand-binding pockets of PLTP somehow exclude neutral lipids. In fact, the binding pockets of PLTP must be somewhat flexible as they can accommodate a wide range of ligand sizes (Kostner et al. 1995; Nishida and Nishida 1997; Rao et al. 1997). Perhaps the reason PLTP does not transfer neutral lipids under normal circumstances is not because it can't bind them in its ligand-binding pockets, but rather that it cannot access the neutral lipids in the core of the lipoproteins. Kinetic studies imply that the C-terminal helix of CETP is involved in the rate-limiting step of neutral lipid transfer (Wang et al. 1995), and our current model of CETP suggests that the helix facilitates the extraction of the lipid from the core of the lipoprotein. If the rate-limiting step of extracting the lipids from the lipoprotein core could be overcome by PLTP, then perhaps the protein could transfer neutral lipids. We proposed, therefore, that if the CETP C-terminal helix was attached to the PLTP, it should be able to extract the neutral lipid from lipoproteins, and allow them to move into the ligand-binding pocket of PLTP, thereby enabling PLTP to facilitate neutral lipid transfer. However, this was not the case, as PLTP with its tail replaced by that of CETP did not gain either CE or TG transfer activity. This would suggest that the helix alone does not confer neutral lipid transfer capability to CETP. On the other hand, the two chimeras composed primarily of CETP, with the carboxy-terminal tail replaced by that of PLTP (CP and CPHIS) were also incapable of neutral lipid transfer. Thus the tail region of PLTP is unable to compensate for the equivalent region of CETP.

Although CETP does not mediate mass transfer of phospholipid, it can facilitate the exchange of phospholipid among lipoproteins (Tall et al. 1983). Mutations and deletions in the C-terminus do not decrease this activity, and in some cases even stimulate it (Wang et al. 1992). The difference between the activities of PLTP and CETP in the *in vitro* liposome to HDL<sub>3</sub> assay may be due to the differential interaction of the two proteins with the phospholipid vesicles. The interaction of CETP with lipoproteins has been shown to be dependent on the negative surface charge of the lipoprotein (Nishida et al. 1993), which can be conferred by the presence of apolipoproteins. Thus the interaction of CETP with protein-free PC vesicles may be weaker than that of PLTP. As PLTP-lipoprotein interactions seem to be mediated by residues away from the C-terminus (Huuskonen et al. 1999; Desrumaux et al. 2001), we would not expect the binding of the CP or CPHIS chimeras to the vesicles to be any stronger than that of the wildtype CETP. However, we thought that the C-terminal of PLTP may be involved in some other aspect of PL transfer, and that by replacing this part of CETP with the equivalent part of PLTP, we would be able to confer PLTP-like PL transfer activity to CETP. In fact, the constructs CP and CPHIS did not gain PL transfer activity, and we concluded that the carboxyl terminus of PLTP is not solely responsible for enabling the protein to transfer phospholipid from vesicles to HDL<sub>3</sub>.

Taken together, our results suggest that, for both PLTP and CETP, a specific combination of residues in the C-terminus and elsewhere in the protein are required for each protein's specific activity. In terms of the CETP tail, energy minimization modeling predicts that the helix lies across the opening to the amino-terminal lipid binding pocket, forming some kind of 'lid'. Perhaps residues in or at the entrance to the binding pocket

need to directly interact with residues in the C-terminal tail in order to allow the neutral lipid to move from the lipoprotein core into the CETP pocket. The PLTP tail may perform a similar function to that of CETP, forming a lid across one or both of the lipid binding pockets.

On the other hand, the mechanisms of lipid transfer by CETP and PLTP are thought to be different. While CETP acts as a 'shuttle', carrying neutral lipids back and forth between lipoproteins, PLTP generates a 'bridge' in order to lower the energy barrier of transfer between donor and acceptor particles (Connolly et al. 1996; Lalanne and Ponsin 2000). Thus, although the carboxy-terminal regions have been shown to be critical for function in both proteins, perhaps the basis for these requirements are different. For example, the longer tail of PLTP may form part of the bridge between donor and acceptor particles, while the tail of CETP releases neutral lipids from the lipoprotein core.

Residues throughout both proteins have been shown to be essential for function as well, highlighting the fact that the overall protein structure is important. For example, some residues in the hydrophobic cluster that were shown to be important for PLTP activity are conserved in CETP, but others are not, and perhaps some of these amino acids contribute to the lipid specificity of PLTP (Desrumaux et al. 2001). It is possible that amino acid substitutions in the carboxy terminal tails of PLTP and CETP cause a subtle change in protein conformation that prevents specific lipid transfer by each protein.

## **Anti-PLTP Antibodies**

Various groups have attempted to produce anti-PLTP antibodies, with limited success. A major difficulty is that the protein is extremely hydrophobic, and therefore not a good soluble antigen. This is compounded by the fact that two of the most commonly used animals for antibody production, mice and rabbits, have PLTP that is highly homologous to the human protein. Initially, our recombinant PLTP was purified from *E.coli* in a denatured form, and we began immunizing mice with this protein. Although the protein was not pure, as visualized on SDS-PAGE, PLTP appeared to be the major component of the mixture. Also, we thought that the insoluble aggregate which formed during dialysis to remove the urea and low pH buffer may have been more immunogenic than a soluble protein.

Later, we produced and purified native recombinant protein from CHO cell media, which was glycosylated, folded and active. The final boost was given intravenously with this soluble antigen in the hope that we might stimulate B-cells that were producing antibodies to native epitopes on the PLTP molecule. Although sera from some of these mice reacted with the bacterial PLTP on ELISA and on Western blot, unfortunately, none of the hybridomas produced recognized PLTP. As there is such a high degree of sequence homology between the mouse and human PLTP, it is possible that the mice mounted only a weak immune response to the human PLTP. Instead they may have responded to either the hexaHIS tag on the recombinant protein, or to a contaminating protein. This could account for the positive ELISA results. Although the Western blot with the pooled sera looked like at least one mouse out of the five was producing antibodies specific for PLTP, two mice were sacrificed due to illness, and it is

possible that one of these had been producing the anti-PLTP antibodies. Unfortunately, at this stage the mice were not individually identified.

At this point we designed a new strategy based on the concept that immunization with naked plasmid DNA encoding the protein of interest could result in a highly specific immune response towards that protein in its native form (Davis 1997; Donnelly et al. 1997). Various reports have shown that either intradermal (id) or intramuscular (im) injections with very little DNA can produce long lasting responses. We chose to use id injections of DNA, due to the simplicity of the technique, and the high density of antigen presenting cells (APCs) in the skin. However, if the injections are too deep (subcutaneous), there are few APCs and the desired response may not be observed. We were able to demonstrate that the immunization was successful, as ELISAs against PLTP expressed in both bacterial and mammalian systems showed that sera from two mice had PLTP-specific antibodies after three injections. In addition, serum from one mouse reacted on Western blot with recombinant PLTP from transiently transfected COS cells and media, and purified mammalian PLTP, but not with other proteins containing a hexaHIS epitope. However, the fusion from this mouse produced hybridomas that either lost reactivity during subcloning and growth, or that were reactive to non-specific proteins on ELISA and Western blot. Fusion from the second mouse did not produce any positive hybridoma clones at all.

When immunizing with protein, the final boost is given intravenously 3 to 4 days before harvesting the spleen, as this is the established time for antigen-specific B-lymphoblasts to migrate there (Milne et al. 1992). It has not been determined whether a similar migration to the spleen would occur in this time frame, if at all, when the final

boost is DNA, given intradermally. Perhaps although it seemed we had anti-PLTP antibodies in the serum after DNA immunization, we did not obtain PLTP-specific hybridomas because of the timing, type, or location of the final boost.

In addition to our own efforts to produce anti-PLTP antibodies, we were generously given samples of several other antibodies to test and use. Dr. X.C Jiang (Columbia University, New York) used an adenovirus expression system to produce a rabbit polyclonal antibody, but we have never been able to show reactivity of this antibody on immunoblots with any of our recombinant PLTP samples. Dr. S. Marcovina (Northwest Research Laboratories, Seattle, WA) produced a murine monoclonal antibody, mAb4, which reacts with inactive PLTP but not active PLTP from human plasma (Murdoch et al. 2002). We found that mAb4 reacted on Western blot with PLTP purified from CHO cell media, and the cellular form of PLTP in transiently transfected COS-7 cells; however, it did not react with the mature form of PLTP in the media from transfected COS-7 cells. It is unclear why these antibodies react under some conditions against some samples, but not others. It may be in part due to poor sensitivity, or slight differences between the antigen used for immunization and the samples tested on the blots.

### **Ongoing and Future Work**

It was somewhat surprising that none of the chimeras tested had any PLTP-specific PL, CE, or TG transfer activity despite being efficiently expressed and secreted. It would be interesting to determine whether there are any defects in lipid or HDL binding ability of each construct that could be hindering activity. Also, to date we have

only tested these chimeras for a limited number of functions, and although the activities studied were those in which the C-terminal tails have been implicated, there are still several other functions to be tested. For example, both CETP and PLTP can exchange phospholipid between lipoproteins; therefore we would expect that each of our chimeras would have this ability as well. As the HDL conversion activity of PLTP is important *in vivo* in terms of overall HDL metabolism and reverse cholesterol transport, it would be useful to determine if any of the PLTP/CETP chimeras possess this activity. It would also be interesting to investigate the structural basis of the selective uptake ability of cell-surface CETP by determining the activity of the chimeras. This activity is diminished by TP2 binding (Benoist et al 1997), but neutral lipid transfer is not required, as inactive mutants are still capable of mediating selective uptake (Zha,X., Milne,R., and McPherson,R., unpublished results)

The 'tilted peptide' model describes how the C-terminal helix of CETP could interact with lipoproteins, and in fact, a synthetic peptide representing CETP residues 461 to 476 has been shown to cause the contents of a lipid vesicle to be released from its core. To investigate whether the CETP C-terminal helix indeed acts as a 'tilted peptide', we are collaborating with Dr. Robert Brasseur (Faculté Universitaire des Sciences Agronomiques de Gembloux, Belgium) to generate a novel CETP mutant in which the native helix is replaced by a model helix that could penetrate the phospholipid monolayer of lipoproteins at approximately the same angle as the native helix. This mutant could also show whether the helical structure alone is sufficient, or whether particular residues within the native helix are specifically required for neutral lipid transfer.

Our results suggest that a more specific interaction of the C-terminal tail with one or both of the lipid-binding pockets is required for the transfer activities of CETP and PLTP. In order to test this theory, I prepared DNA constructs to express two further chimeras, each having one binding pocket from CETP and one from PLTP (ie. bpN-CETP/bpC-PLTP, and bpN-PLTP/bpC-CETP). Again, these chimeras were based on the models of CETP and PLTP structure, and the amino acid alignments with BPI, and were designed in collaboration with Dr. Lesa Beamer. In each of these chimeras, the carboxy-terminal region and the amino acids forming the central  $\beta$ -sheet between the two binding pockets are from CETP. Structural models of these chimeras are shown in Figure 19. BPI/LBP fusions of this type were successfully expressed and purified from CHO cells, and were used to identify the role of each lipid binding pocket (Abrahamson et al. 1997; Iovine et al. 2002). These two proteins share 45% amino acid homology, whereas CETP and PLTP share just 20%. We are hoping that these chimeras can help answer questions about whether each of the the two binding pockets of the proteins bind specific lipids, and whether the carboxy-terminal tail of CETP interacts with residues in one or both binding pockets. If we are able to express and test the activities of these two chimeras, we plan to produce another two CETP/PLTP binding pocket chimeras, each with the carboxy-terminus and the central connecting region from PLTP.

In case the lack of neutral lipid transfer activity of the 'PC' construct was due to insufficient flexibility of the CETP tail helix, 2 glycine residues were inserted just after the natural flexible linker region between residues 464 and 465 (PGGC). Unfortunately, this construct was never detected on Western blot in either cell lysate or media with any of the CETP C-terminal tail antibodies. It is quite possible that the epitopes are lost with

**Figure 19. Structural models of two binding pocket chimeras of CETP and PLTP.**

**A) CETP<sub>1-16</sub>/PLTP<sub>11-184</sub>/CETP<sub>200-476</sub>**

The carboxy-terminal  $\beta$ -barrel and the central  $\beta$ -sheet are from CETP: residues 1 to 16 (cyan) and 200 to 476 (purple). The amino-terminal  $\beta$ -barrel is from PLTP: residues 11 to 184 (green).

**B) CETP<sub>1-266</sub>/PLTP<sub>253-418</sub>/CETP<sub>432-476</sub>**

The amino-terminal  $\beta$ -barrel and the central  $\beta$ -sheet are from CETP: residues 1 to 266 (red) and 432 to 476 (blue). The carboxy-terminal  $\beta$ -barrel is from PLTP: residues 253 to 418 (yellow).

A

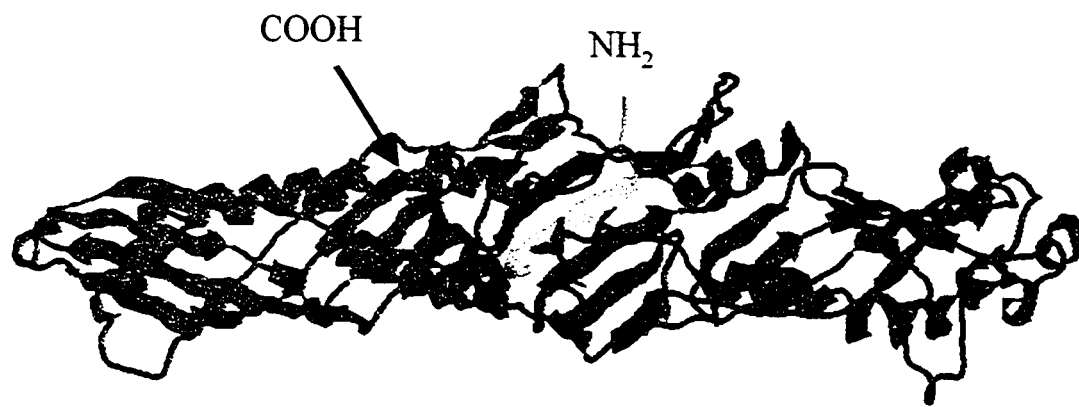

N-terminal  
 $\beta$ -barrel (PLTP)

Central  
 $\beta$ -sheet (CETP)

C-terminal  
 $\beta$ -barrel (CETP)

B

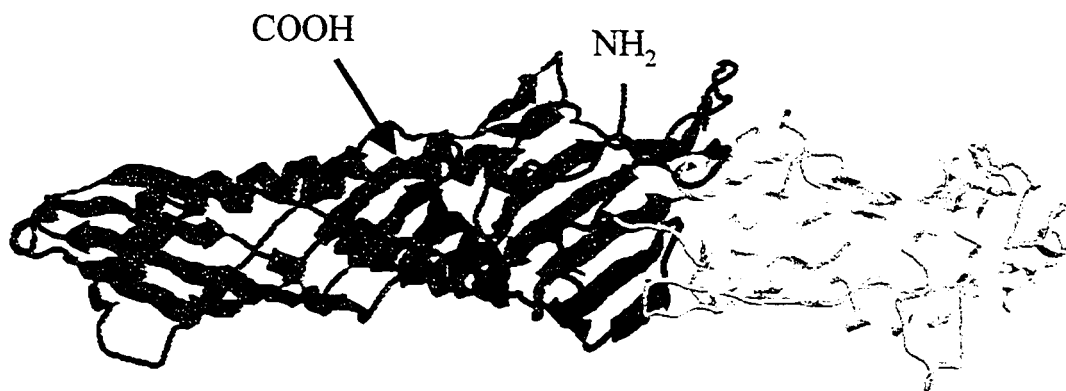

N-terminal  
 $\beta$ -barrel (CETP)

Central  
 $\beta$ -sheet (CETP)

C-terminal  
 $\beta$ -barrel (PLTP)

the insertion of residues at this position, as several of the point mutants between residues 460 and 476 result in severely diminished TP2 binding (Wang et al. 1993). However, we were not able to distinguish between a loss of the epitopes and a lack of protein expression.

We had hoped to have an anti-PLTP antibody that we could use to detect and quantify some of the chimeric proteins relative to wildtype PLTP, but as no antibodies were successfully produced, we have not yet completed the study of the 'PC' and 'PGGC' constructs. As we could not determine the relative amounts of wildtype PLTP and PC, we were unable to obtain data on the phospholipid transfer activity of PC. However, based on the results that we do have, it seems unlikely that this construct would have any activity. We were also unable to make any conclusions about the expression of the 'PGGC' protein, or to test its activity. Antibodies to PLTP should also enable us to investigate the binding pocket chimeras in terms of PL transfer activity.

We are continuing our efforts to produce monoclonal murine anti-PLTP antibodies by DNA immunization, but we are now using intramuscular injections of DNA, and the final boost is an intravenous injection of recombinant PLTP protein purified from CHO cell media. We would also like to try using PLTP KO mice for immunization, however, because of positive serology of available PLTP KO strains, we have been unable to introduce the mice into our animal facility.

Concurrently, we are investigating the possibility of using chickens to produce an antibody to a specific peptide within the PLTP sequence. Based on the structural model of PLTP, we chose to synthesize a peptide that was relatively non-hydrophobic, and which was predicted to form an  $\alpha$ -helix in an exposed position. A peptide of PLTP

residues 141 to 157 has been synthesized and conjugated to keyhole limpet hemocyanin (KLH). Chickens were immunized 3 times at 2 week intervals, and serum and eggs are to be collected following the immunization (Resgen). A blast search of this peptide did not reveal any chicken sequences, and we are hoping to obtain eggs containing IgY specific for the PLTP peptide.

### **Summary**

In this study, we tested the hypothesis that the carboxy-termini of PLTP and CETP are responsible for determining the different lipid specificities of the two transfer proteins. The results of our experiments to date with C-terminal tail chimeras of PLTP and CETP suggest that the carboxy terminal region alone does not confer neutral lipid transfer capability to CETP, or PLTP-specific PL transfer activity to PLTP. Rather, the carboxy-terminal region must co-operate with other parts of the molecule to facilitate lipid transfer in both cases. In order to investigate this further, we have prepared DNA to express a fourth C-terminal tail swap chimera (PGGC), as well as two binding pocket chimeras of PLTP and CETP. In addition, we are continuing our efforts to produce monoclonal antibodies to human PLTP, which we hope will be useful for future structure-function studies of PLTP.

## References

- Abrahamson, S.L., Wu, H.M., Williams, R.E., Der, K., Ottah, N., Little, R., Gazzano-Santoro, H., Theofan, G., Bauer, R., Leigh, S., Orme, A., Horwitz, A.H., Carroll, S.F., and Dedrick, R.L. (1997) Biochemical characterization of recombinant fusions of lipopolysaccharide binding protein and bacteriocidal/permeability-increasing protein. Implications in biological activity. *J. Biol. Chem.* **272**: 2149-2155.
- Acton, S., Rigotti, A., Landschulz, K.T., Xu, S., Hobbs, H.H., and Krieger, M. (1996) Identification of scavenger receptor SR-BI as a high density lipoprotein receptor. *Science.* **271**: 518-20.
- Agellon, L.B., Walsh, A., Hayek, T., Moulin, P., Jiang, X.C., Shelanski, S.A., Breslow, J.L., and Tall, A.R. (1991) Reduced high density lipoprotein cholesterol in human cholesteryl ester transfer protein transgenic mice. *J Biol Chem* **266**: 10796-801.
- Albers, J.J., Tollefson, J.H., Chen, C.H., and Steinmetz, A. (1984) Isolation and characterization of human plasma lipid transfer proteins. *Arteriosclerosis* **4**: 49-58.
- Albers, J.J., Wolfbauer, G., Cheung, M.C., Day, J.R., Ching, A.F., Lok, S., and Tu, A.Y. (1995) Functional expression of human and mouse plasma phospholipid transfer protein: effect of recombinant and plasma PLTP on HDL subspecies. *Biochim. Biophys. Acta* **1258**: 27-34.
- Barter, P.J., and Rye, K.A. (1996) Molecular mechanisms of reverse cholesterol transport. *Curr Opin Lipidol* **7**: 82-7
- Beamer, L.J., Carroll, S.F. and Eisenberg, D. (1997) Crystal structure of human BPI and two bound phospholipids at 2.4 angstrom resolution. *Science* **276**: 1861-1864.
- Beamer, L.J., Carroll, S.F. and Eisenberg, D. (1998) The BPI/LBP family of proteins: a structural analysis of conserved regions. *Protein Sci.* **7**: 906-914.
- Beamer, L.J., Carroll, S.F. and Eisenberg, D. (1999) The three-dimensional structure of human bacteriocidal/permeability-increasing protein: implications for understanding protein-lipopolysaccharide interactions. *Biochem. Pharmacol.* **57**: 225-229.
- Benoist, F., Lau, P., McDonnell, M., Doelle, H., Milne, R., and McPherson, R. (1997) Cholesteryl ester transfer protein mediates selective uptake of high density lipoprotein cholesteryl esters by human adipose tissue. *J Biol Chem* **272**: 23572-7.
- Bisgaier, C.L., Siebenkas, M.V., Brown, M.L., Inazu, A., Koizumi, J., Mabuchi, H., and Tall, A.R. (1991) Familial cholesteryl ester transfer protein deficiency is associated with triglyceride-rich low density lipoproteins containing cholesteryl esters of probable intracellular origin. *J Lipid Res* **32**: 21-33.

- Bolanos-Garcia, V.M., Soriano-Garcia, M., and Mas-Oliva, J. (1998) Stability of the C-terminal peptide of CETP mediated through an (i, i + 4) array. *Biochim Biophys Acta* **1384**: 7-15.
- Brasseur, R., Pilot, T., Vandekerckhove, J., and Rosseneu, M. (1997) Peptides in membranes: tipping the balance of membrane stability. *Trends Biochem. Sci.* **22**: 167-171.
- Brown, M.L., Inazu, A., Hesler, C.B., Agellon, L.B., Mann, C., Whitlock, M.E., Marcel, Y.L., Milne, R.W., Koizumi, J., and Mabuchi, H., et al. (1989) Molecular basis of lipid transfer protein deficiency in a family with increased high-density lipoproteins. *Nature* **342**: 448-51.
- Bruce, C., Chouinard, R.A., Jr. and Tall, A.R. (1998a) Plasma lipid transfer proteins, high-density lipoproteins, and reverse cholesterol transport. *Annu. Rev. Nutr.* **18**: 297-330.
- Bruce, C., Beamer, L.J. and Tall, A.R. (1998b). The implications of the structure of the bactericidal/permeability-increasing protein on the lipid-transfer function of the cholesteryl ester transfer protein. *Curr. Opin. Struct. Biol.* **8**: 426-434.
- Collet, X., Tall, A.R., Serajuddin, H., Guendouzi, K., Royer, L., Oliveira, H., Barbaras, R., Jiang, X.C., and Francone, O.L. (1999). Remodeling of HDL by CETP in vivo and by CETP and hepatic lipase in vitro results in enhanced uptake of HDL CE by cells expressing scavenger receptor B-I. *J Lipid Res* **40**: 1185-93.
- Connolly, D.T., McIntyre, J., Heuvelman, D., Remsen, E.E., McKinnie, R.E., Vu, L., Melton, M., Monsell, R., Krul, E.S., and Glenn, K. (1996) Physical and kinetic characterization of recombinant human cholesteryl ester transfer protein. *Biochem J* **320**: 39-47.
- Damen, J., Regts, J., and Scherphof, G. (1982) Transfer of [<sup>14</sup>C]phosphatidylcholine between liposomes and human plasma high density lipoprotein. Partial purification of a transfer-stimulating plasma factor using a rapid transfer assay. *Biochim Biophys Acta* **712**: 444-52.
- Davis, H.L. (1997) Plasmid DNA expression systems for the purpose of immunization. *Curr. Opin. Biotechnol.* **8**: 635-640.
- Day, J.R., Albers, J.J., Lofton-Day, C.E., Gilbert, T.L., Ching, A.F., Grant, F.J., O'Hara, P.J., Marcovina, S.M., and Adolphson, J.L. (1994) Complete cDNA encoding human phospholipid transfer protein from human endothelial cells. *J. Biol. Chem* **269**: 9388-9391.
- Desrumaux, C., Athias, A., Masson, D., Gambert, P., Lallemand, C., and Lagrost, L. (1998) Influence of the electrostatic charge of lipoprotein particles on the activity of the human plasma phospholipid transfer protein. *J. Lipid Res.* **39**: 131-142.

- Desrumaux, C., Athias, A., Bessede, G., Verges, B., Farnier, M., Persegol, L., Gambert, P., and Lagrost, L. (1999) Mass concentration of plasma phospholipid transfer protein in normolipidemic, type IIa hyperlipidemic, type IIb hyperlipidemic, and non-insulin-dependent diabetic subjects as measured by a specific ELISA. *Arterioscler. Thromb. Vasc. Biol.* **19**: 266-275.
- Desrumaux, C., Labeur, C., Verhee, A., Tavernier, J., Vandekerckhove, J., Rosseneu, M., and Peelman, F. (2001) A hydrophobic cluster at the surface of the human plasma phospholipid transfer protein is critical for activity on high density lipoproteins. *J. Biol. Chem.* **276**: 5908-5915.
- Donnelly, J.J., Ulmer, J.B., Shiver, J.W., and Liu, M.A. (1997) DNA Vaccines. *Annu Rev Immunol* **15**: 617-48.
- Drayna, D., Jarnagin, A.S., McLean, J., Henzel, W., Kohr, W., Fielding, C., and Lawn, R. (1987) Cloning and sequencing of human cholesteryl ester transfer protein cDNA. *Nature* **327**: 632-4.
- Ehnholm, S., van Kijk, K.W., van't Hof, B., van der Zee, A., Olkkonen, V.M., Jauhiainen, M., Hofker, M., Havekes, L., and Ehnholm, C. (1998) Adenovirus mediated overexpression of human phospholipid transfer protein alters plasma HDL levels in mice. *J. Lipid Res.* **39**: 1248-1253.
- Epps, D.E., and Vosters, A.F. (2002) The essential role of a free sulfhydryl group in blocking the cholesteryl site of cholesteryl ester transfer protein (CETP). *Chem Phys Lipids* **114**: 113-22.
- Föger, B., Santamarina-Fojo, S., Shamburek, R.D., Parrot, C.L., Talley, G.D., and Brewer, H.B.Jr. (1997) Plasma phospholipid transfer protein - Adenovirus-mediated overexpression in mice leads to decreased plasma high density lipoprotein (HDL) and enhanced hepatic uptake of phospholipids and cholesteryl esters from HDL. *J. Biol. Chem.* **272**: 27393-27400.
- Frohlich J, Dobiasova M, Lear S, Lee KW. (2001) The role of risk factors in the development of atherosclerosis. *Crit Rev Clin Lab Sci* **38**: 401-40.
- Gama, L., and Breitwieser, G.E. (1999) Generation of epitope-tagged proteins by inverse PCR mutagenesis. *Biotechniques* **26**: 814-6.
- Gander, R., Eller, P., Kaser, S., Theurl, I., Walter, D., Sauper, T., Ritsch, A., Patsch, J.R., and Foger, B. (2002) Molecular characterization of rabbit phospholipid transfer protein: choroid plexus and ependyma synthesize high levels of phospholipid transfer protein. *J. Lipid Res* **43**: 636-45.
- Glenn, K.C., and Melton, M.A. (1995) Quantification of Cholesteryl Ester Transfer Protein: Activity and Immunochemical Assay. *Methods Enzymol* **263**: 339-351.

- Gotto, A.M., Jr., Pownall, H.J. and Havel, R.J. (1986) Introduction to the plasma lipoproteins. *Methods Enzymol.* **128**: 3-41.
- Guyard-Dangremont, V., Desrumaux, C., Gambert, P., Lallemand, C., and Lagrost, L. (1998) Phospholipid and cholesteryl ester transfer activities in plasma from 14 vertebrate species. Relation to atherogenesis susceptibility. *Comp Biochem Physiol B Biochem Mol Biol* **120**: 517-25.
- Guyard-Dangremont, V., Tenekjian, V., Chauhan, V., Walter, S., Roy, P., Rassart, E., and Milne, R.W. (1999) Immunochemical evidence that cholesteryl ester transfer protein and bactericidal/permeability-increasing protein share a similar tertiary structure. *Protein Sci* **8**:2392-8.
- Ha, Y.C., and Barter, P.J. (1982) Differences in plasma cholesteryl ester transfer activity in sixteen vertebrate species. *Comp Biochem Physiol B* **71**: 265-9.
- Havel, R.J., Eder, H.A., and Bragdon, J.H. (1955) The distribution and chemical composition of ultracentrifugally separated lipoproteins in human serum. *J Clin Invest* **34**: 1345-1353.
- Hayek, T., Chajek-Shaul, T., Walsh, A., Agellon, L.B., Moulin, P., Tall, A.R., and Breslow, J.L. (1992) An interaction between the human cholesteryl ester transfer protein (CETP) and apolipoprotein A-I genes in transgenic mice results in a profound CETP-mediated depression of high density lipoprotein cholesterol levels. *J Clin Invest* **90**: 505-10.
- Hayek, T., Masucci-Magoulas, L., Jiang, X., Walsh, A., Rubin, E., Breslow, J.L., and Tall, A.R. (1995) Decreased early atherosclerotic lesions in hypertriglyceridemic mice expressing cholesteryl ester transfer protein transgene. *J Clin Invest* **96**: 2071-4.
- Hesler, C.B., Tall, A.R., Swenson, T.L., Weech, P.K., Marcel, Y.L., and Milne, R.W. (1988) Monoclonal antibodies to the Mr 74,000 cholesteryl ester transfer protein neutralize all of the cholesteryl ester and triglyceride transfer activities in human plasma. *J. Biol. Chem* **263**: 5020-5023.
- Hesler, C.B., Brown, M.L., Feuer, D.S., Marcel, Y.L., Milne, R.W., and Tall, A.R. (1989) Structure-function analysis of plasma cholesteryl ester transfer protein by protease digestion and expression of cDNA fragments in *Escherichia coli*. *J. Biol. Chem* **264**: 11317-11325.
- Hirano, K., Yamashita, S., Nakajima, N., Arai, T., Maruyama, T., Yoshida, Y., Ishigami, M., Sakai, N., Kameda-Takemura, K., and Matsuzawa, Y. (1997) Genetic cholesteryl ester transfer protein deficiency is extremely frequent in the Omagari area of Japan. Marked hyperalphalipoproteinemia caused by CETP gene mutation is not associated with longevity. *Arterioscler Thromb Vasc Biol* **17**: 1053-9.

- Hope, H.R., Heuvelman, D., Duffin, K., Smith, C., Zablocki, J., Schilling, R., Hegde, S., Lee, L., Witherbee, B., Baganoff, M., Bruce, C., Tall, A.R., Krul, E., Glenn, K., and Connolly, D.T. (2000) Inhibition of cholesteryl ester transfer protein by substituted dithiobisnicotinic acid dimethyl ester: involvement Of a critical cysteine. *J Lipid Res* **41**: 1604-14.
- Horwitz, A.H., Leigh, S.D., Abrahamson, S., Gazzano-Santoro, H., Liu, P.S., Williams, R.E., Carroll, S.F., and Theofan, G. (1996) Expression and characterization of cysteine-modified variants of an amino-terminal fragment of bactericidal/permeability-increasing protein. *Protein Expr Purif* **8**:28-40.
- Huuskonen, J., Olkkonen, V.M., Jauhiainen, M., Metso, J., Somerharju, P., and Ehnholm, C. (1996) Acyl chain and headgroup specificity of human plasma phospholipid transfer protein. *Biochim. Biophys. Acta Lipids Lipid Metab.* **1303**: 207-214.
- Huuskonen, J., Jauhiainen, M., Ehnholm, C. and Olkkonen, V.M. (1998) Biosynthesis and secretion of human plasma phospholipid transfer protein. *J. Lipid Res.* **39**: 2021-2030.
- Huuskonen, J., Wohlfahrt, G., Jauhiainen, M., Ehnholm, C., Teleman, O., and Olkkonen, V.M. (1999) Structure and phospholipid transfer activity of human PLTP: analysis by molecular modeling and site-directed mutagenesis. *J. Lipid Res.* **40**: 1123-1130.
- Huuskonen, J., Ekstrom, M., Tahvanainen, E., Vainio, A., Metso, J., Pussinen, P., Ehnholm, C., Olkkonen, V.M., and Jauhiainen, M. (2000a) Quantification of human plasma phospholipid transfer protein (PLTP): relationship between PLTP mass and phospholipid transfer activity. *Atherosclerosis* **151**: 451-461.
- Huuskonen, J., and Ehnholm, C. (2000b) Phospholipid transfer protein in lipid metabolism. *Curr Op Lipdol* **11**: 285-289.
- Huuskonen, J., Olkkonen, V.M., Ehnholm, C., Metso, J., Julkuunen, I., and Jauhiainen, M. (2000c) Phospholipid transfer is a prerequisite for PLTP-mediated HDL conversion. *Biochemistry* **39**: 16092-16098.
- Huuskonen, J., Olkkonen, V.M., Jauhiainen, M. and Ehnholm, C. (2001) The impact of phospholipid transfer protein (PLTP) on HDL metabolism. *Atherosclerosis* **155**: 269-281.
- Ikewaki, K., Rader, D.J., Sakamoto, T., Nishiwaki, M., Wakimoto, N., Schaefer, J.R., Ishikawa, T., Fairwell, T., Zech, L.A., Nakamura, H., et al. (1993) Delayed catabolism of high density lipoprotein apolipoproteins A-I and A-II in human cholesteryl ester transfer protein deficiency. *J Clin Invest* **92**: 1650-8.
- Inazu, A., Jiang, X.C., Haraki, T., Yagi, K., Kamon, N., Koizumi, J., Mabuchi, H., Takeda, R., Takata, K., and Moriyama, Y., et al. (1994) Genetic cholesteryl ester transfer protein deficiency caused by two prevalent mutations as a major determinant of increased levels of high density lipoprotein cholesterol. *J Clin Invest* **94**: 1872-82.

- Inoue H, Nojima H, Okayama H. (1990) High efficiency transformation of *Escherichia coli* with plasmids. *Gene* **96**: 23-8.
- Iovine, N., Eastvold, J., Elsbach, P., Weiss, J.P., and Gioannini, T.L. (2002) The carboxyl-terminal domain of closely related endotoxin-binding proteins determines the target of protein-lipoplysaccharide complexes. *J Biol Chem* **277**: 7970-8.
- Jauhiainen, M., Metso, J., Pahlman, R., Blomqvist, S., van Tol, A., and Ehnholm, C. (1993) Human plasma phospholipid transfer protein causes high density lipoprotein conversion. *J. Biol. Chem* **268**: 4032-4036.
- Jauhianen, M., Huuskonen, J., Baumann, M., Metso, J., Oka, T., and Egashira T. (1999) Phospholipid transfer protein (PLTP) causes proteolytic cleavage of apolipoprotein A-I. *J Lipid Res* **40**: 654-664.
- Jiang, X.C., Moulin, P., Quinet, E., Goldberg, I.J., Yacoub, L.K., Agellon, L.B., Compton, D., Schnitzer-Polokoff, R., and Tall, A.R. (1991) Mammalian adipose tissue and muscle are major sources of lipid transfer protein mRNA. *J Biol Chem* **266**: 4631-9.
- Jiang, X.C., Masucci-Magoulas, L., Mar, J., Lin, M., Walsh, A., Breslow, J.L., and Tall, A. (1993) Down-regulation of mRNA for the low density lipoprotein receptor in transgenic mice containing the gene for human cholesteryl ester transfer protein. Mechanism to explain accumulation of lipoprotein B particles. *J Biol Chem* **268**: 27406-12.
- Jiang, X.C. and Bruce, C. (1995a). Regulation of murine plasma phospholipid transfer protein activity and mRNA levels by lipopolysaccharide and high cholesterol diet. *J. Biol. Chem* **270**: 17133-17138.
- Jiang, X.C., Bruce, C., Cocke, T., Wang, S., Boguski, M., and Tall, A.R. (1995b). Point mutagenesis of positively charged amino acids of cholesteryl ester transfer protein: conserved residues within the lipid transfer/lipopolysaccharide binding protein gene family essential for function. *Biochemistry* **34**: 7258-7263.
- Jiang, X.C., Francone, O.L., Bruce, C., Milne, R., Mar, J., Walsh, A., Breslow, J.L., and Tall, A.R. (1996) Increased pre $\beta$ -high density lipoprotein, apolipoprotein AI, and phospholipid in mice expressing the human phospholipid transfer protein and human apolipoprotein AI transgenes. *J. Clin. Invest.* **98**: 2373-2380.
- Jiang, X.C., Bruce, C., Mar, J., Lin, M., Ji, Y., Francone, O.L., and Tall, A.R. (1999) Targeted mutation of plasma phospholipid transfer protein gene markedly reduces high-density lipoprotein levels. *J. Clin. Invest.* **103**: 907-914.
- Jiang, X.C., Qin, S., Qiao, C., Kawano, K., Lin, M., Skold, A., Xiao, X., and Tall, A.R. (2001) Apolipoprotein B secretion and atherosclerosis are decreased in mice with phospholipid-transfer protein deficiency. *Nat Med* **7**: 847-52.

Karkkainen, M., Oka, T., Olkkonen, V.M., Metso, J., Hattori, H., Jauhiainen, M., and Ehnholm, C. (2002) Isolation and partial characterization of the inactive and active forms of human plasma phospholipid transfer protein (PLTP). *J Biol Chem* **277**: 15413-8.

Kawano, K., Qin, S.C., Lin, M., Tall, A.R. and Jiang, X.C. (2000) Cholesteryl ester transfer protein and phospholipid transfer protein have nonoverlapping functions *in vivo*. *J. Biol. Chem* **275**: 29477-29481.

Kleiger, G., Beamer, L.J., Grothe, R., Mallick, P. & Eisenberg, D. (2000) The 1.7 Å crystal structure of BPI: A study of how two dissimilar amino acid sequences can adopt the same fold. *J. Mol. Biol.* **299**: 1019-1034.

Ko, K.W.S., Ohnishi, T. and Yokoyama, S. (1994) Triglyceride transfer is required for net cholesteryl ester transfer between lipoproteins in plasma by lipid transfer protein. Evidence for a hetero-exchange transfer mechanism demonstrated by using novel monoclonal antibodies. *J. Biol. Chem* **269**: 28206-28213.

Kostner, G.M. Oettl, K., Jauhiainen, M., Ehnholm, C., Esterbauer, H., and Dieplinger, H. (1995) Human plasma phospholipid transfer protein accelerates exchange/transfer of  $\alpha$ -tocopherol between lipoproteins and cells. *Biochem J.* **305**: 659-667.

Kwiterovich, P.O.Jr. (1998) The antiatherogenic role of high-density lipoprotein cholesterol. *Am. J. Cardiol.* **82**: 13Q-21Q.

Lalanne, F. and Ponsin, G. (2000) Mechanism of the phospholipid transfer protein-mediated transfer of phospholipids from model lipid vesicles to high density lipoproteins. *Biochim. Biophys. Acta* **1487**: 82-91.

Lamping, N., Hoess, A., Yu, B., Park, T.C., Kirschning, C.J., Pfeil, D., Reuter, D., Wright, S.D., Herrmann, F., and Schumann, R.R. (1996) Effects of site-directed mutagenesis of basic residues (Arg 94, Lys 95, Lys 99) of lipopolysaccharide (LPS)-binding protein on binding and transfer of LPS and subsequent immune cell activation. *J Immunol* **157**: 4648-56.

Lusa, S., Jauhiainen, M., Metso, J., Somerharju, P. and Ehnholm, C. (1996) The mechanism of human plasma phospholipid transfer protein-induced enlargement of high-density lipoprotein particles: evidence for particle fusion. *Biochem J.* **313**: 275-282.

Marcel, Y.L., McPherson R., Hogue, M., Czarnecka, H., Zawadzki, Z., Weech, P.K., Whitlock, M.E., Tall, A.R., and Milne, R.W. (1990). Distribution and concentration of cholesteryl ester transfer protein in plasma of normolipidemic subjects. *J. Clin. Invest.* **85**: 10-17.

Marotti, K.R., Castle, C.K., Boyle, T.P., Lin, A.H., Murray, R.W., and Melchior, G.W. (1993) Severe atherosclerosis in transgenic mice expressing simian cholesteryl ester transfer protein. *Nature* **364**: 73-5.

- Melchior, G.W., Greenlee, K.A., Castle, C.K., Prough, M.J., Milne, R.W., Marotti, K.R., and Kezdy, F.J. (1995) Evidence that cynomolgus monkey cholesteryl ester transfer protein has two lipid binding sites. *J. Biol. Chem* **270**: 21068-21074.
- Milne, R.W., Weech, P.K., and Marcel, Y.L. (1992) Immunological methods for studying and quantifying lipoproteins and apolipoproteins. *In* Lipoprotein analysis; A practical approach. Edited by C.A. Converse and E.R. Skinner. Oxford University Press, New York. pp. 145-168.
- Moriyama, Y., Okamura, T., Inazu, A., Doi, M., Iso, H., Mouri, Y., Ishikawa, Y., Suzuki, H., Iida, M., Koizumi, J., Mabuchi, H., and Komachi, Y. (1998) A low prevalence of coronary heart disease among subjects with increased high-density lipoprotein cholesterol levels, including those with plasma cholesteryl ester transfer protein deficiency. *Prev Med* **27**: 659-67.
- Morton, R.E. and Zilversmit, D.B. (1982) Purification and characterization of lipid transfer protein(s) from human lipoprotein-deficient plasma. *J. Lipid Res* **23**: 1058-1067.
- Morton, R.E., and Zilversmit, D.B. (1983) Inter-relationship of lipids transferred by the lipid-transfer protein isolated from human lipoprotein-deficient plasma. *J Biol Chem* **258**: 11751-7.
- Murdoch, S.J., Wolfbauer, G., Kennedy, H., Marcovina, S.M., Carr, M.C., and Albers, J.J. (2002) Differences in reactivity of antibodies to active versus inactive PLTP significantly impacts PLTP measurement. *J Lipid Res* **43**: 281-9.
- Nagashima, M., McLean, J.W., and Lawn, R.M. (1988) Cloning and mRNA tissue distribution of rabbit cholesteryl ester transfer protein. *J Lipid Res* **29**: 1643-9.
- Nishida, H.I., Arai, H., and Nishida, T. (1993). Cholesterol ester transfer mediated by lipid transfer protein as influenced by changes in the charge characteristics of plasma lipoproteins. *J Biol Chem* **268**: 16352-60.
- Nishida, H.I. and Nishida, T. (1997). Phospholipid transfer protein mediates transfer of not only phosphatidylcholine but also cholesterol from phosphatidylcholine cholesterol vesicles to high density lipoproteins. *J. Biol. Chem.* **272**: 6959-6964.
- Ohnishi, T., Tan, C., and Yokoyama, S. (1994) Selective transfer of cholesteryl ester over triglyceride by human plasma lipid transfer protein between apolipoprotein-activated lipid microemulsions. *Biochemistry.* **33**: 4533-42.
- Oka, T., Kujiraoka, T., Ito, M., Egashira, T., Takahashi, S., Nanjee, M.N., Miller, N.E., Metso, J., Olkkonen, V.M., Ehnholm, C., Jauhiainen, M., and Hattori, H. (2000a). Distribution of phospholipid transfer protein in human plasma: presence of two forms of phospholipid transfer protein, one catalytically active and the other inactive. *J Lipid Res* **41**: 1651-7.

- Oka, T., Kujiraoka, T., Ito, M., Nagano, M., Ishihara, M., Iwasaki, T., Egashira, T., Miller, N.E., and Hattori, H. (2000b) Measurement of human plasma phospholipid transfer protein by sandwich ELISA. *Clin. Chem.* **46**: 1357-1364.
- Oliveira, H.C., Ma, L., Milne, R., Marcovina, S.M., Inazu, A., Mabuchi, H., and Tall, A.R. (1997). Cholesteryl ester transfer protein activity enhances plasma cholesteryl ester formation - Studies in CETP transgenic mice and human genetic CETP deficiency. *Arterioscler. Thromb. Vasc. Biol.* **17**: 1045-1052.
- Pape, M.E., Rehberg, E.F., Marotti, K.R. and Melchior, G.W. (1991) Molecular cloning, sequence, and expression of cynomolgus monkey cholesteryl ester transfer protein. Inverse correlation between hepatic cholesteryl ester transfer protein mRNA levels and plasma high density lipoprotein levels. *Arteriosclerosis Thrombosis* **11**: 1759-1771.
- Parthasarathy, S., Steinberg, D., Witztum, J.L. (1992) The role of oxidized low-density lipoproteins in the pathogenesis of atherosclerosis. *Annu Rev Med* **43**: 219-25.
- Pattanaik, N.M., Montes, A., Hughes, L.B. and Zilversmit, D.B. (1978) Cholesteryl ester exchange protein in human plasma isolation and characterization. *Biochim. Biophys. Acta* **530**: 428-438.
- Perez-Mendez, O., Decout, A., Vandekerckhove, J., Brasseur, R., and Rosseneu. (1997) Abstract in *Atherosclerosis* **134**: 371.
- Pussinen, P.J., Olkkonen, V.M., Jauhiainen, M. and Ehnholm, C. (1997) Molecular cloning and functional expression of cDNA encoding the pig plasma phospholipid transfer protein. *J. Lipid Res* **38**: 1473-1481.
- Qin, S.C., Kawano, K., Bruce, J., Lin, M., Bisgaier, C., Tall, A.R., and Jiang, X.C. (2000) Phospholipid transfer protein gene knock-out mice have low high density lipoprotein levels, due to hypercatabolism, and accumulate apoA-IV-rich lamellar lipoproteins. *J. Lipid Res.* **41**: 269-276.
- Rao, R., Albers, J.J., Wolfbauer, G. and Pownall, H.J. (1997) Molecular and macromolecular specificity of human plasma phospholipid transfer protein. *Biochemistry* **36**: 3645-3653.
- Ross, R. (1999) Atherosclerosis—an inflammatory disease. *N Engl J Med* **340**: 115-26.
- Roy, P., MacKenzie, R., Hiramata, T., Jiang, X.C., Kussie, P., Tall, A., Rassart, E., and Milne, R. (1996) Structure-function relationships of human cholesteryl ester transfer protein: Analysis using monoclonal antibodies. *J. Lipid Res.* **37**: 22-34.
- Rye, K.A., and Barter, P.J. (1986) Changes in the size and density of human high-density lipoproteins promoted by a plasma-conversion factor. *Biochim Biophys Acta* **875**: 429-38.

- Sakai, N., Yamashita, S., Hirano, K., Ishigami, M., Arai, T., Kobayashi, K., Funahashi, T., and Matsuzawa, Y. (1995) Decreased affinity of low density lipoprotein (LDL) particles for LDL receptors in patients with cholesteryl ester transfer protein deficiency. *Eur J Clin Invest* **25**: 332-9.
- Sambrook, J., Fritsch, E.F., and Maniatis, T. (1989) *Molecular Cloning: A Laboratory Manual*. Cold Spring Harbor Laboratory Press, NY.
- Sayle, R.A., Milner-White, E.J. (1995) RASMOL: biomolecular graphics for all. *Trends Biochem Sci* **20**: 374
- Settasatian, N., Duong, M., Curtiss, L.K., Ehnholm, C., Jauhiainen, M., Huuskonen, J., and Rye, K.A. (2001) The mechanism of the remodeling of high density lipoproteins by phospholipid transfer protein. *J. Biol. Chem.* **276**: 26898-26905.
- Stevenson, S.C., Wang, S., Deng, L., and Tall, A.R. (1993) Human plasma cholesteryl ester transfer protein consists of a mixture of two forms reflecting variable glycosylation at asparagine 341. *Biochemistry* **32**: 5121-6.
- Swenson, T.L., Brocia, R.W., and Tall, A.R. (1988) Plasma cholesteryl ester transfer protein has binding sites for neutral lipids and phospholipids. *J Biol Chem* **263**:5150-7.
- Swenson, T.L., Hesler, C.B., Brown, M.L., Quinet, E., Trotta, P.P., Haslanger, M.F., Gaeta, F.C., Marcel, Y.L., Milne, R.W., and Tall, A.R. (1989) Mechanism of cholesteryl ester transfer protein inhibition by a neutralizing monoclonal antibody and mapping of the monoclonal epitope. *J. Biol. Chem* **264**: 14318-14326.
- Takahashi, K., Jiang, X.C., Sakai, N., Yamashita, S., Hirano, K., Bujo, H., Yamazaki, H., Kusunoki, J., Miura, T., Kussie, P., et al. (1993) A missense mutation in the cholesteryl ester transfer protein gene with possible dominant effects on plasma high density lipoproteins. *J Clin Invest* **92**: 2060-4.
- Tall, A.R., Abreu, E. and Schuman, J.S. (1983). Separation of plasma phospholipid transfer protein from cholesterol ester/phospholipid exchange protein. *J. Biol. Chem* **258**: 2174-2186.
- Tall, A.R., Krumholtz, S., Olivecrona, T. and Deckelbaum, R.J. (1985) Plasma phospholipid transfer protein enhances transfer and exchange of phospholipids between very low density lipoproteins and high density lipoproteins during lipolysis. *J. Lipid Res* **26**: 842-851.
- Tollefson, J.H., Ravnik, S. and Albers, J.J. (1988) Isolation and characterization of a phospholipid transfer protein (LTP-II) from human plasma. *J. Lipid Res* **29**: 1593-1602.
- Tu, A.Y., Nishida, H.I. and Nishida, T. (1993) High density lipoprotein conversion mediated by human plasma phospholipid transfer protein. *J. Biol. Chem* **268**: 23098-23105.

- Tu, A.Y., Deeb, S.S., Day, J.R. and Albers, J.J. (1995) Organization of human phospholipid transfer protein gene. *Biochem. Biophys. Res. Commun.* **207**: 552-558.
- van Haperen, R., van Tol, A., Vermeulen, P., Jauhiainen, M., van Gent, T., van den Berg, P., Ehnholm, S., Grosveld, F., van der Kamp, A., and de Crom, R. (2000) Human plasma phospholipid transfer protein increases the antiatherogenic potential of high density lipoproteins in transgenic mice. *Arterioscler. Thromb. Vasc. Biol.* **20**: 1082-1088.
- van Tol, A. (2002) Phospholipid Transfer Protein. *Curr Op Lipidol* **13**: 135-139.
- Wang, S., Brown, M.L., Agellon, L.B. and Tall, A.R. (1991). Structure-function studies of human cholesteryl ester transfer protein by linker insertion scanning mutagenesis. *Biochemistry* **30**: 3484-3490.
- Wang, S., Deng, L., Milne, R.W. and Tall, A.R. (1992) Identification of a sequence within the C-terminal 26 amino acids of cholesteryl ester transfer protein responsible for binding a neutralizing monoclonal antibody and necessary for neutral lipid transfer activity. *J. Biol. Chem* **267**: 17487-17490.
- Wang, S., Wang, X., Deng, L., Rassart, E., Milne, R.W., and Tall, A.R. (1993) Point mutagenesis of carboxyl-terminal amino acids of cholesteryl ester transfer protein. Opposite faces of an amphipathic helix important for cholesteryl ester transfer or for binding neutralizing antibody. *J. Biol. Chem* **268**: 1955-1959.
- Wang, S., Kussie, P., Deng, L. and Tall, A.R. (1995) Defective binding of neutral lipids by a carboxy-terminal deletion mutant of cholesteryl ester transfer protein. Evidence for a carboxyl-terminal cholesteryl ester binding site for neutral lipid transfer activity. *J. Biol. Chem* **270**: 612-614.
- Whitmore, T.E., Day, J.R. and Albers, J.J. (1995) Localization of the human phospholipid transfer protein gene to chromosome 20q12-q13.1. *Hum. Gene Ther.* **28**: 599.
- Yamashita, S., Sprecher, D.L., Sakai, N., Matsuzawa, Y., Tarui, S., and Hui, D.Y. (1990) Accumulation of apolipoprotein E-rich high density lipoproteins in hyperalphalipoproteinemic human subjects with plasma cholesteryl ester transfer protein deficiency. *J Clin Invest* **86**: 688-95.
- Yang, C.H., and Zwieb, C. (2001). Swapping of functional domains using a chimeric monster deletion mutagenesis strategy. *Biotechniques* **31**: 724, 726, 728.
- Yen, F.T., Deckelbaum, R.J., Mann, C.J., Marcel, Y.L., Milne, R.W., and Tall, A.R. (1989) Inhibition of cholesteryl ester transfer protein activity by monoclonal antibody. Effects on cholesteryl ester formation and neutral lipid mass transfer in human plasma. *J. Clin. Invest* **83**: 2018-2024.

Zhong, S., Sharp, D.S., Grove, J.S., Bruce, C., Yano, K., Curb, J.D., and Tall, A.R. (1996) Increased coronary heart disease in Japanese-American men with mutation in the cholesteryl ester transfer protein gene despite increased HDL levels. *J Clin Invest* **97**: 2917-23.

## Statement of Contributions of Collaborators

I have done the majority of the work presented in this paper, with contributions from the following people: All of the images of structural models were prepared by Dr. Ross Milne. The design of all of the chimeric proteins was done in collaboration with Dr. Lesa Bearner. Dr. Valerie Guyard-Dangremont prepared the PLTP-blunt-TOPO DNA construct. Reema Harish, a summer student under my supervision, prepared the CETP<sub>1-460</sub>/PLTP<sub>445-476</sub>-pCMV5 (CP) DNA, and did some of the preliminary expression studies of this construct. Rick Magun, also under my supervision, prepared the CETP-NheI(370)-pCMV5 and the CETP-NheI(1007)-pCMV5 DNA constructs. Suzanne Davenport shared the antibody work with me. For some experiments, Gerard Vassiliou prepared the <sup>3</sup>H-CE-labeled HDL.

## Stephanie M. Walter

### Education

*Bachelor of Science, Honours, Biochemistry*

Queen's University at Kingston

Graduated May 1997 with First Class Honours

*Scholarships:* Canada Scholarship 1993-1997

Queen's University Tricolour Scholarship 1993-1995

*Masters of Science, Biochemistry*

University of Ottawa

Expected date of graduation: November 2002

*Scholarships:* Natural Sciences and Engineering Research Council of Canada 2000-2002

Strategic Areas of Development Scholarship 2000-2002

University of Ottawa Excellence Scholarship 2000-2002

*Other Courses*

French Language Training (intermediate). New Avenues Linguistics. 1999-2000

Journalistic Writing. Algonquin college, Ottawa. 1999.

### Publications

Chauhan, V., **Walter, S.**, Nguyen, A.T., and Milne, R. Cholesteryl ester transfer protein: Structure, function, and role in atherosclerosis. *Recent Research Developments Lipids*. 2001. 5: 37-45.

**Walter, S.** Working to Fill the Gap: Students, educators, and the private sector are counting on biotech co-op programs to build a competitive industry. *Biotechnology Focus*. 2000. Jan/Feb; 3(1): 20-21.

Guyard-Dangremont V, Tenekjian V, Chauhan V, **Walter S**, Roy P, Rassart E, Milne RW. Immunochemical evidence that cholesteryl ester transfer protein and bactericidal/permeability-increasing protein share a similar tertiary structure. *Protein Science*. 1999 Nov;8(11):2392-8.

## **Experience**

*Laboratory Technician*, University of Ottawa Heart Institute. Supervisor: Dr. Ross Milne. Nov.1998 - Sept.2000.

*Work / Travel in Australia*: New South Wales Cancer Council, office work, live-in nanny. Sept 1997 - Aug. 1998

*Research Assistant*, Cancer Research Laboratories, Queen's University. Supervisor: Dr. Martin Petkovich. May - Aug1997.

*Research Assistant*, Queen's University Biochemistry Department. Supervisor: Dr. John Elce. May - Aug1996.

*Screening and Information Officer*, Health and Welfare Canada, Bureau of Non-prescription drugs. May – Aug.1995.