

Exploring the effect of maternal physical activity and placental region on
mitochondrial protein content and function in the placenta

Jonathan Rankin, BSc

Thesis submitted to
The Faculty of Graduate and Postdoctoral Studies
University of Ottawa
In partial fulfillment of the requirements for the master's degree in the
School of Human Kinetics

© Jonathan Rankin, Ottawa, Canada, 2019

Abstract

The placenta is responsible for mediating fetal growth and development, thereby influencing health across the lifespan. Physical activity (PA) confers benefits to mother and baby during pregnancy, but little is known about its impact on the placenta. There were two purposes of this study: i) to determine if maternal PA during pregnancy influences placenta mitochondrial protein content and function, and ii) to determine if there were differences in placenta mitochondrial protein content and function in different regions of the placenta, namely proximal or distal to the centre of the placenta. Healthy women between 12-28 weeks gestation were recruited, and free-living PA was objectively assessed at multiple time points during pregnancy using an accelerometer. Participants were grouped by minutes of moderate-to-vigorous PA (MVPA) per day. Placenta tissue samples were collected from central and distal placental regions immediately post-birth and were used for two separate analyses. Half of the samples were flash frozen in liquid nitrogen and used for western blot analysis of mitochondrial complex I-V proteins. Fresh mitochondria were isolated from the other half of the samples, and high-resolution respirometry was used to measure placental mitochondrial respiration. There were significant positive correlations between maternal PA and mitochondrial protein content in peripheral tissue samples, but protein content was significantly higher in central tissue compared to peripheral tissue samples. In addition, state 3 respiration was higher in central tissue samples of placentas from participants with high MVPA compared to participants with low MVPA. Finally, complex I protein was higher in central tissue samples of placentas from female offspring compared to placentas of male offspring. However, many of these results are underpowered and further study is warranted. This study provides new avenues to explore the relationship between PA and placenta mitochondria in healthy populations.

Acknowledgements

First, I would like to give a sincere thanks to my amazing supervisor, Dr. Kristi Adamo. Kristi has been the driving force for the completion of my Master's degree. She has motivated and guided me throughout this process and has challenged me to think and act independently. Kristi has always been her students' number one advocate, and I am so grateful to have worked with this superwoman for the last 2.5 years. I would also like to thank my committee members, Dr. Keir Menzies and Dr. Mike De Lisio. The success of my thesis would not have been possible without your guiding comments and questions. A special thanks to Keir, who assisted me greatly with my respirometry protocols when I felt completely lost.

My Master's journey started when I met Dr. Zach Ferraro in undergrad. He mentored and guided me to choosing Kristi's lab for volunteering, and ultimately for pursuing my graduate studies. Thank you, Zach, for your wisdom and experience, and for being my favourite lecturer in my undergrad. A huge thanks to the two research coordinators on the PLACENTA study that I worked with over the course of my degree. Alysha, your work and facilitation in the main project, as well as the students' individual projects, was invaluable. Rose, you guided me through the final stages of my analyses, and I'm so thankful for your input and advice.

Of course, I did not go through this journey alone. The other students in my lab made my degree infinitely more interesting and rewarding, for which I am grateful. Kat, you started as my friendly next-door (desk) neighbor, but here we are as very good friends. I'm so happy we went through this journey together, from the lab to conferences, and now finally to our separate end-goals. I'm so proud of what you've accomplished. Ashley, you and I were the first students of this "generation" in Kristi's lab, and though we had different paths, I'm thankful for the

friendship we have. Pegah, Lyra, and Kelly, though we knew each other for less time I'm happy to have gotten to know you. Last but not least, thanks to Shuhiba for all of her continued work in our lab. Shuhiba, you helped me immensely throughout the process of my degree, from study design to helping with data collection for nearly all the subjects. I absolutely could not have done this without you, and I will take the things I've learned from you wherever I go.

I had incredible help and support from some of our collaborators at our partner labs at RGN. Alexanne, you were so patient with me when I was learning how to do my analysis and work in your lab. I cannot thank you enough for the time and effort you put into helping me with my project, and answering so many questions. Jeremiah, you also went above and beyond what I would have hoped for in helping me achieve my goals for my project. Dr. Yan Burelle, thank you for also taking the time to help troubleshoot my analysis when I was stuck. Kim and Phil, thanks for answering my questions and talking through things with me.

My experience over the last two years was greatly enriched by my friends and family. To all of the friends I've gained throughout this degree, thank you for giving me the opportunity to share experiences, or just unwind. Thanks to Darrin, Kevin, Wes, Maji, Kaamel, Tyler, and Jenn for making my two years much more enjoyable. I'd also like to acknowledge my opportunity to be involved with the HKGSA as Co-VP Social, and to thank the rest of the council for their hard work and dedication for entertaining, educating, and advocating for our student body.

Of course, thanks to my family for their support and wise words. They are my foundation and my inspiration. Lastly, special thanks to my wonderful girlfriend Vikki. She helped guide me through the final stages of this degree and was always caring and understanding of the time sacrifices required for thesis writing. Thanks for always motivating me to be more when I want to just give up, and for making me laugh and smile when I need it most.

Table of Contents

Abstract.....	ii
Acknowledgements.....	iii
Glossary of Terms.....	vii
List of Figures.....	viii
List of Tables.....	ix
Statement of Contribution of Collaborators.....	x
Chapter 1 – Introduction.....	1
1.1 Fetal Programming.....	1
1.2 The Role of the Placenta.....	2
1.2.1 Offspring Sex Differences During Development.....	5
1.2.2 Placental Regions.....	6
1.3 Relationship Between the Placenta and Physical Activity.....	7
1.4 Mitochondria.....	8
1.4.1 The Electron Transport Chain and Oxidative Phosphorylation.....	9
1.4.2 Mitochondrial Biogenesis.....	11
1.5 Physical Activity and Mitochondria.....	12
1.6 High-Resolution Respirometry.....	14
1.7 Study Rationale.....	17
1.8 Research Aims.....	19
1.9 Hypotheses.....	19
Chapter 2 - Methods.....	21
2.1 Participants.....	21
2.2 Participant visits and accelerometer data capture.....	22
2.3 Tissue collection and preparation.....	23
2.4 Western blots.....	24
2.5 High-resolution respirometry.....	26
2.5.1 Mitochondrial isolation.....	26
2.5.2 Oxygraph analysis.....	26
2.6 Statistical analyses.....	29
2.6.1 Effects of PA on mitochondrial protein content.....	29
2.6.2 Effects of PA on mitochondrial respiration.....	29

2.6.3 Regional differences in the placenta	30
2.6.4 Analyses by offspring sex	30
Chapter 3 - Results.....	31
3.1 Study Population Demographics.....	31
3.2 Analysis by MVPA.....	33
3.2.1 Effects of MVPA on mitochondrial protein content.....	33
3.2.2 Effects of MVPA on mitochondrial respiration.....	38
3.3 Analysis by Placenta Region	39
3.3.1 Regional differences in mitochondrial protein content.....	39
3.3.2 Regional differences in mitochondrial function	41
3.4 Analyses by Offspring Sex	42
3.4.1 Differences in mitochondrial protein content between offspring sexes.....	42
3.4.2 Differences in mitochondrial function between offspring sexes	43
Chapter 4 – Discussion	44
4.1 Effect of PA on mitochondrial protein content & function	44
4.2 Regional differences in the placenta	46
4.3 Offspring Sex	47
4.4 Mechanism of the effect of PA on the placenta.....	48
4.5 Limitations	50
4.6 Conclusion	53
References.....	54
Appendix A: Western Blot Protocol.....	71
Appendix B: High-Resolution Respirometry Protocol.....	73
Appendix C: Calculated statistical power and estimated required sample size for the statistically-significant findings of the study.....	80

Glossary of Terms

ADP: adenosine diphosphate

ATP: adenosine triphosphate

CCP: carbonyl cyanide m-chlorophenyl hydrazone

CI: mitochondrial complex I

CII: mitochondrial complex II

CIII: mitochondrial complex II

CIV: mitochondrial complex IV

CV: mitochondrial complex V

CPAG: Canadian Physical Activity Guidelines

DOHAD: Developmental Origins of Health and Disease

ETC: electron transport chain

GDM: gestational diabetes mellitus

GWG: gestational weight gain

HRR: high-resolution respirometry

LGA: large for gestational age

mtDNA: mitochondrial DNA

MVPA: moderate to vigorous physical activity

OPS: Oxygraph Plus System

OXPPOS: oxidative phosphorylation

PA: physical activity

PGC-1 α : peroxisome proliferator-activated receptor gamma coactivator 1-alpha

ROS: reactive oxygen species

S3: state III respiration

TMPD: N, N, N', N'-tetramethyl-p-phenylenediamine

WHO: World Health Organization

List of Figures

Figure 1. Diagram of the human placenta.....	4
Figure 2. Placental membrane separating the blood in the fetal capillaries from the maternal blood in the intervillous space.....	5
Figure 3. Diagram of the electron transport chain in mitochondria.....	11
Figure 4. Diagram of SUIIT protocol reagents, and their effect on the electron transport chain	16
Figure 5. Example placental OPS tracing showing O ₂ concentration over time during the experiment....	17
Figure 6. Placenta sampling diagram	24
Figure 7. Oxygraph data from two individual experiments	28
Figure 8. Gel images from western blot analysis	35
Figure 9. The relationship between average daily moderate-to-vigorous physical activity during the 2 nd trimester and total relative protein quantity in placenta by region	36
Figure 10. The relationship between average daily moderate-to-vigorous physical activity during the 2 nd trimester and complex II protein quantity in placenta by region	36
Figure 11. The relationship between average daily moderate-to-vigorous physical activity during the 2 nd trimester and complex I protein quantity in placenta by region.....	37
Figure 12. The relationship between average daily moderate-to-vigorous physical activity during the 2 nd trimester and complex V protein quantity in placentas of female offspring by region.....	37
Figure 13. Mitochondrial respiration data from central and peripheral placenta tissue, grouped by physical activity status.....	38
Figure 14. Comparison of placental mitochondrial protein content by placental region.....	40
Figure 15. Comparison of mitochondrial protein content in placentas of female and male offspring by placental region.	40
Figure 16. Comparison of mitochondrial respiration data by placental region.....	41
Figure 17. Comparison of mitochondrial respiration data in placentas of female and male offspring by placental region.	42
Figure 18. Comparison of mitochondrial protein content by offspring sex..	43
Figure 19. Comparison of mitochondrial respiration data by offspring sex.....	43

List of Tables

Table 1. Study inclusion and exclusion criteria.....	22
Table 2. Study population demographics for the mitochondrial protein content analysis.....	32
Table 3. Participant and offspring characteristics for the mitochondrial respiration analysis.....	33

Statement of Contribution of Collaborators

I, Jonathan Rankin, hereby declare that I am the sole author of this Master's thesis. The work contained in this thesis is my own, and I take full responsibility for its content. This thesis contains data that was collected as part of the larger Physical Activity and dietary implications Throughout pregnancy (PLACENTA) study. The PLACENTA study was funded by CIHR (MOP-142298), awarded to Dr. Kristi Adamo. Ethical approval was obtained from several Research Ethics Boards, including: the Ottawa Health Science Network (Protocol# 20160178-01H), the Children's Hospital of Eastern Ontario (REB# 16/68X), Hôpital Montfort (#LG-01-06-16), University of Ottawa (#H11-15-29), Queensway Carleton Hospital (File# 17-03). The PLACENTA study was designed by my supervisor, Kristi Adamo. I was responsible for the placenta tissue collection of over 30 women throughout the time spent in my MSc. For the purpose of this thesis, the data from the placenta mitochondria component for 17 women is presented. Data analysis and statistical analyses were completed by myself under the guidance of Dr. Kristi Adamo, who also provided editorial corrections.

Chapter 1 – Introduction

1.1 Fetal Programming

In 1990, David Barker proposed the “thrifty phenotype” hypothesis, wherein aspects of a person’s health throughout the lifespan can be traced back to their intrauterine environment (D. J. Barker, 1990). In the time since this hypothesis was advanced, many researchers have investigated the effects of undernutrition and being born small-for-gestational-age (SGA) on cardiovascular disease (D. J. P. Barker, 2000), hypertension (Strachan & Hart, 1990), and type 2 diabetes (Dabelea et al., 2000) later in life. More recently, many studies have found that the relationship between birth weight and early life comorbidities lies on a U-shaped curve, where those being born SGA *or* large-for-gestational-age (LGA) are at risk of developing insulin resistance at 5 years of age (Wilkin et al., 2002), type 2 diabetes before 18 years of age (Wei et al., 2003), and obesity in adolescence (Murtaugh, Jacobs Jr., Moran, Steinberger, & Sinaiko, 2003). This broadening of Barker’s original hypothesis has led to a new and growing field of study referred to as “Developmental Origins of Health and Disease” (DOHaD).

Chronic disease has become a major problem worldwide, resulting in widespread morbidity and mortality (WHO, 2005). Obesity is an example of a chronic disease whose prevalence has risen dramatically over the past 40 years, especially among children and youth (Roberts, Shields, de Groh, Aziz, & Gilbert, 2012). In Canada, excess weight gain and physical inactivity are among the top 5 risk factors most attributable to disease burden (Krueger, Krueger, & Koot, 2015). In 2013, these two risk factors alone directly cost \$10 billion to Canadian society, increasing to \$30 billion when indirect costs are considered (Krueger et al., 2015). Moreover, obesity is a risk factor for a plethora of chronic conditions (Brown, Fujioka, Wilson,

& Woodworth, 2009), and is often difficult to treat and manage (Wooley & Garner, 1991) and virtually impossible to cure (Ochner, Tsai, Kushner, & Wadden, 2015). A systematic review by Trimmel *et al.* (2017) indicated that there is an urgent need for obesity prevention worldwide. In line with the principles of DOHAD, the World Health Organization (WHO) (WHO, 2007) and Obesity Canada (Lau et al., 2007) have both indicated pregnancy as an optimal timeframe for interventions for preventing obesity. Women who gain excessive weight during pregnancy are more likely to retain their pregnancy weight up to 6 months postpartum (Gunderson & Abrams, 2000), and are more at risk for becoming obese later in life (Rooney & Schauburger, 2002). As well, excessive gestational weight gain (GWG) based on the 2009 Institute of Medicine (IOM) guidelines (Institute of Medicine, 2009) has a large impact on a child's birthweight (Hull et al., 2011), which is subsequently a risk factor for obesity later in life (Johnsson, Haglund, Ahlsson, & Gustafsson, 2015). Healthy physical activity (PA) and dietary behaviours are independently associated with guideline-concordant GWG (Olson & Strawderman, 2003). However, the exact mechanisms are not well understood. More research is needed to examine the effects of diet and PA on the intrauterine environment. The following sections will focus on PA and its role during pregnancy, how PA may impact the placenta, and subsequently the role of mitochondria within these relationships.

1.2 The Role of the Placenta

The placenta is a transient organ that regulates the exchange of gases and nutrients vital to the fetus' growth and development. It functions as a surrogate for the kidneys, lungs, gastrointestinal tract, and endocrine glands of the fetus (Jansson & Powell, 2007). The placenta is, in part, self-regulatory, producing its own blood vessels and villous trees to adapt to the changing environment *in utero* (Cross & Mickelson, 2006). The ability of the placenta to

perform these functions is in part related to its morphology (Fowden, Forhead, Coan, & Burton, 2008). Placental size, villous volume, and adequate blood flow are important factors in determining optimal placental nutrient transport (Harding, 2001).

Nutrient transport in the placenta occurs at the junction between the placental villi, which stem from the fetal blood circulation, and the intervillous space bathed in maternal blood. At this junction, three main cell types are found: syncytiotrophoblasts, cytotrophoblasts, and endothelial cells (Wang Y, 2010). Syncytiotrophoblasts form a continuous layer on the outer portion of the placental villi and act as the main barrier between maternal and fetal blood circulation. Just beneath the layer of syncytiotrophoblasts are cytotrophoblasts, undifferentiated cells that continuously differentiate into syncytiotrophoblasts during the pregnancy to allow for villous development. At the core of the placental villi are the villous capillaries which are enclosed by endothelial cells that are sensitive to angiogenic changes relating to placental growth (Wang Y, 2010). Figure 1 shows the structure of human placenta, and Figure 2 shows the structure and cell types present in placental villi (Medical Dictionary, 2011).

One critical role of the placenta is to protect the fetus by preventing harmful substances from entering the fetal circulation. The placenta is capable of maintaining a favourable physiological environment for the growing fetus in the presence of adverse conditions like pathogen exposure by providing a physical barrier while selectively regulating nutrient transport to the fetus (Jansson & Powell, 2007). The adaptability of the placenta to adverse conditions is limited though, and certain factors such as pregnancy-related diseases or malnutrition can cause the placenta to become maladaptive. These conditions can exacerbate biological stresses within the body that are normally present during pregnancy, such as hypertriglyceridemia, insulin resistance, and pro-inflammatory markers (Stewart et al., 2007). Pregnant women with obesity

are especially vulnerable, as they are more susceptible to pregnancy-related disorders, like gestational diabetes mellitus (GDM), respiratory and hypertensive disorders, as well as placental complications like preeclampsia and intrauterine growth restriction (Aviram, Hod, & Yogev, 2011). The cumulative effect of pregnancy, obesity, and one or more of these complications can put women and their fetuses at high risk for complications.

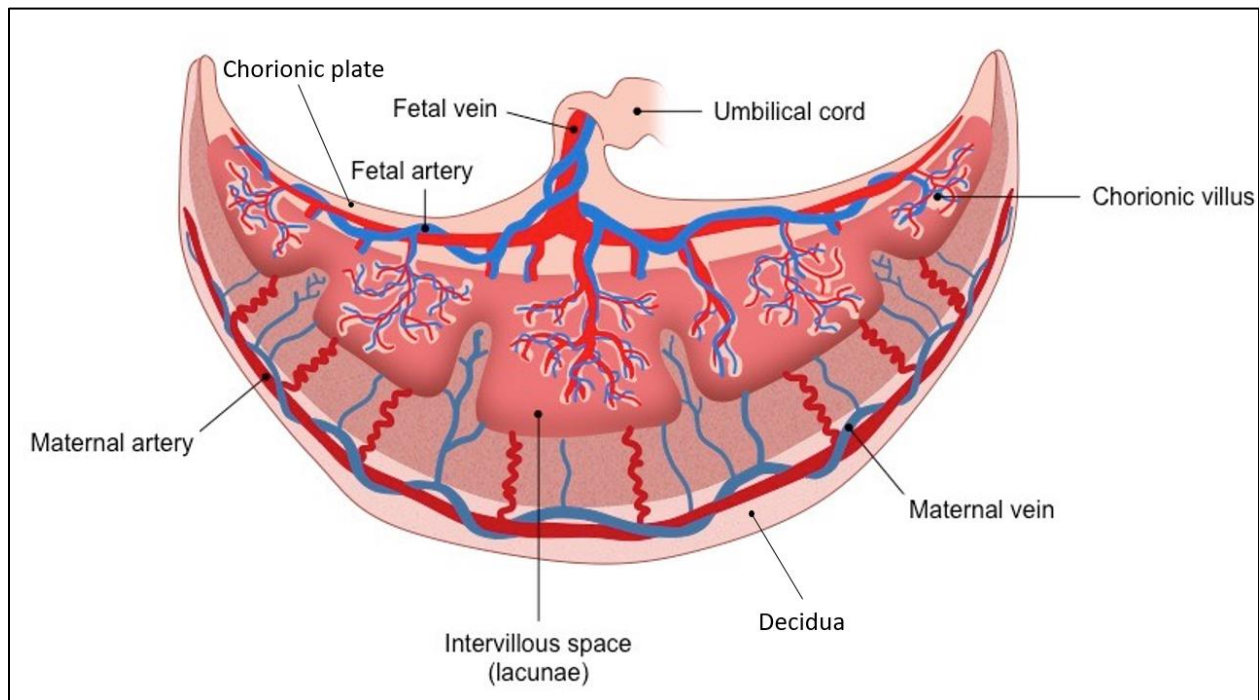

Figure 1. Diagram of the human placenta. Diagram shows the maternal blood vessels invading into the placenta, immersing the placental villi in maternal blood. Adapted from (Cornell, 2016).

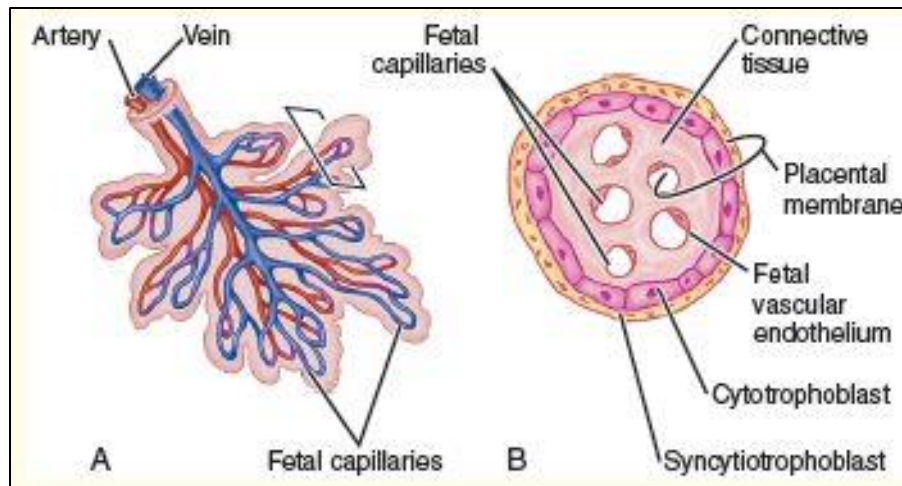

Figure 2. Placental membrane separating the blood in the fetal capillaries from the maternal blood in the intervillous space. A) Chorionic villus containing the fetal vessels and surrounded by maternal blood in the intervillous space; B) cross-section through a villus, showing the layers of the placental membrane separating the fetal blood from the maternal blood surrounding the villus (Medical Dictionary, 2011).

1.2.1 Offspring Sex Differences During Development

Aside from sex-specific physical characteristics, females and males grow differently in the womb. Males tend to be born longer, have higher fetal-to-placental weight ratios, and tend to grow faster *in utero* when compared to females (Eriksson, Kajantie, Osmond, Thornburg, & Barker, 2010). A higher fetal-to-placental weight ratio means that the placenta of a male fetus may be more “efficient,” meaning it may be able to provide nourishment for the development and maintenance of more fetal tissue per unit weight of placenta tissue (Eriksson et al., 2010). Efficiency may come with a cost, where these placentas may have less “reserve capacity,” or are less capable of adapting to adverse conditions (Eriksson et al., 2010). In contrast, females tend to have lower fetal -to -placental weight ratios but may be more adaptive and resilient to adverse changes *in utero* (Eriksson et al., 2010).

A major function of the placenta is to adapt to adverse stimuli, such as inadequate nutrients or oxygen concentrations, to regulate and protect fetal growth and development. The placenta of female offspring responds to adverse stimuli by restricting fetal growth, thus preserving the functionality of the placenta. In contrast, male offspring adopt a riskier growth strategy: their placentas tend not to restrict fetal growth in the presence of adverse stimuli, placing a strain on the placenta (Clifton, 2010). Thus, in the presence of an adverse stimulus, such as pre-eclampsia, the male fetus may sacrifice placental growth and associated vasculature in favour of fetal tissue growth. The underdeveloped placenta in these cases could potentially constrain downstream fetal development. This strategy can lead to a higher risk of pregnancy and birth complications (Di Renzo, Rosati, Sarti, Cruciani, & Cutuli, 2007), as well as a higher incidence of diseases like hypertension later in life (Gilbert & Nijland, 2008).

1.2.2 Placental Regions

The placenta is a heterogenous organ, consisting of many structures and cell types. Different regions of the placenta can differ in thickness, cell type proportions, and blood flow. For instance, through ultrasound and Doppler technology, Jauniaux et al. found that in a healthy pregnant population, the onset of placental-maternal blood circulation occurs first around the edges or periphery of the placenta and spread inwards. However, by mid-gestation, resistance to maternal blood flow is lower in central regions of the placenta compared to the periphery, suggesting increased blood flow to central regions (Jauniaux, Hempstock, Greenwold, & Burton, 2003). Reported differences in blood flow may be in part because placental implants first and deepest in central regions, becoming shallower as placentation spreads to the periphery. These deep placentation sites often have thicker blood vessels with larger plugs than peripheral sites, which take longer to unplug (Jauniaux et al., 2003). However, once the vessel plugs are removed

(approximately 13 weeks of gestation), central blood vessels will provide more blood flow to the placental bed than peripheral sites. It is thus important to consider these regional differences when comparing individual placental tissue samples to each other.

1.3 Relationship Between the Placenta and Physical Activity

Physical activity plays a role in modifying the placenta in both healthy and unhealthy pregnancies (Clapp, Kim, Burciu, & Lopez, 2000). Some studies show that acute bouts of PA during pregnancy redirects absolute blood flow from the placenta and other visceral organs to muscle, which creates periods of intermittent hypoxia in the placenta for the duration of the activity (Clapp, 2003). However, directly after the cessation of the active bout, blood flow normalizes. These bouts of intermittent hypoxia may upregulate angiogenic factors in the placenta, which may result in increased placental tissue growth rate and volume (Clapp et al., 2000). In addition, regular exercise training during pregnancy can reduce the effect of exercise on blood flow redirection and promote consistent blood flow to the uterus (Clapp et al., 2000). Physically active pregnant women show lower maternal serum levels of anti-angiogenic factors soluble fms-like tyrosine kinase-1 (sFlt-1) and soluble endoglin (sEng) and higher maternal serum levels of placental growth factor (PlGF) than physically inactive pregnant women (Weissgerber, Davies, & Roberts, 2010).

A study by Jackson et al. used stereological analysis to estimate the volume and surface area of villous and non-villous placental tissue of 60 physically-active pregnant women (Jackson, Gott, Lye, Knox Ritchie, & Clapp, 1995). They found that women who engaged in aerobic exercise in early to mid-pregnancy had a higher proportion of villous tissue to non-villous tissue in the placenta than women who did not engage in exercise. This higher proportion of villous

tissue is thought to translate into more efficient perfusion per placental weight. Also, properly prescribed exercise can reduce the risk of some pregnancy-related disorders, such as preeclampsia and GDM (Rudra, Sorensen, Luthy, & Williams, 2008, Davenport et al., 2018). Recent reviews by summarize the current state of knowledge on the potential impacts of PA on pregnancy outcomes, including decreased risk of developing preeclampsia and gestational diabetes, decreased risk of having a caesarian section, and optimized fetal birth weight and leanness (Mottola et al., 2018, Ferraro, Gaudet, & Adamo, 2012). The authors indicate that there is little to no risk associated with properly-prescribed PA during pregnancy in women without contraindications.

1.4 Mitochondria

Mitochondria are the main regulators of metabolism in mammalian cells (Krebs & Johnson, 1937; Ogata & Yamasaki, 1997). These organelles are responsible for the production of adenosine triphosphate (ATP), an energy-carrying molecule that is responsible for powering most cellular processes in mammalian cells. To produce enough ATP to meet the demands of the cell, mitochondria require oxygen, supplied by a process called cellular respiration (Smolina, Bruton, Kostareva, & Sejersen, 2017). Mitochondria frequently undergo fusion and fission, exchanging mitochondrial DNA (mtDNA) and repairing damaged components, then proliferating. The relative rates of these processes, also called mitophagy and mitochondrial biogenesis, determines the mitochondrial content of a cell (Yan, Lira, & Greene, 2012).

Mitochondria naturally produce reactive oxygen species (ROS) during ATP production. However, mitochondrial dysfunction may lead to increased production of ROS, which can damage cellular proteins and cause disease (Bragoszewski, Turek, & Chacinska, 2017).

Interestingly, mitochondria are also sensitive to the accumulation of ROS, which can cause deformation and dysfunction of the organelle. Since normal pregnancy is characterized by higher levels of oxidative stress, mitochondria may be especially susceptible to perturbations involving ROS (Holland, Dekker Nitert, et al., 2017).

1.4.1 The Electron Transport Chain and Oxidative Phosphorylation

A large proportion of the ATP utilized at rest is synthesized in the mitochondria through oxidative phosphorylation (OXPHOS) (Hatefi, 1985). OXPHOS is carried out by a set of redox reactions that pass electrons along a chain of protein complexes within the mitochondria called the electron transport chain (ETC). In brief, high-energy electron carrier molecules are reduced by successive protein complexes. The protons released by these reactions are pumped into the intermembrane space, creating an imbalance of electrical potential. These protons will be pumped back out into the matrix through ATP synthase channels, which catalyses the production of ATP from adenosine diphosphate (ADP). Figure 1 shows a diagrammatic representation of this process.

The electron transport chain begins when electron-carrying coenzymes nicotinamide adenine dinucleotide (NADH) and flavin adenine dinucleotide (FADH₂) interact with NADH dehydrogenase (Complex I, CI) and succinate dehydrogenase (Complex II, CII), respectively. NADH is oxidized to NAD⁺ by CI, which transfers 2 electrons to CI and pumps 4 protons into the intermembrane space. FADH₂ is oxidized to FAD by CII, which transfers 2 electrons to CII. Both CI and CII transfer their donated electrons to ubiquinone, which is reduced to ubiquinol. Ubiquinol transfers its donated electrons to Q-cytochrome C oxidoreductase (Complex III, CIII), which then reduces cytochrome C, pumping 4 protons into the intermembrane space.

Cytochrome C passes its donated electrons to cytochrome C oxidase (Complex IV, CIV) which uses the donated electrons to reduce molecular oxygen into water, thus allowing the cycle to be continued and also pumping 2 protons into the intermembrane space, giving a total of 10 protons from one NADH molecule, and 6 protons from FADH₂. Due to the excess protons in the intermembrane space, an electrochemical gradient forms across the membrane. Protons leave the membrane via ATP synthase (Complex V, CV), which in turn catalyses the reaction of combining ADP and phosphate into ATP. The entire process occurs continuously as energy substrates are metabolized in the cell.

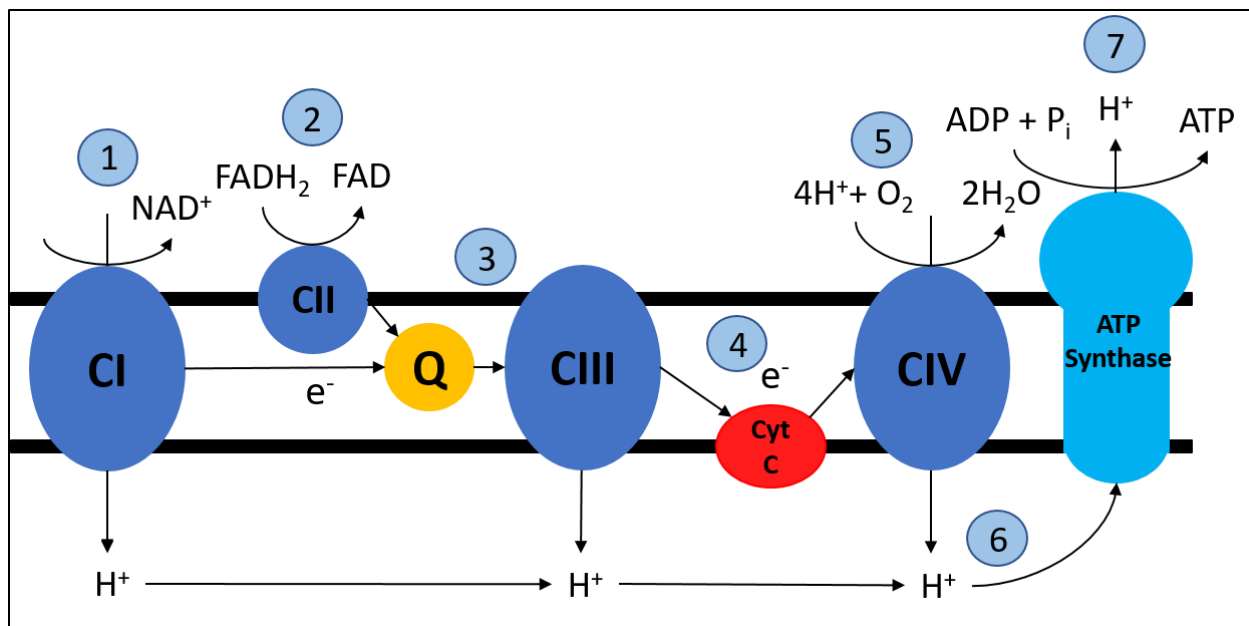

Figure 3. Diagram of the electron transport chain in mitochondria. (1) NADH carries electrons from the Krebs cycle and transfers one to complex I (CI), pumping one hydrogen (H^+) into the intermembrane space. (2) $FADH_2$ deposits two electrons onto complex II (CII). (3) Electrons from CI and CII are transferred to ubiquinone, which are then transferred to complex III (CIII), which pumps more H^+ into the intermembrane space. (4) Electrons from CIII are passed to cytochrome C (Cyt C) and then to complex IV (CIV). (5) Complex IV uses electrons to reduce molecular oxygen to water, which pumps more H^+ into the intermembrane space. (6) Hydrogen atoms exit the intermembrane space along their charge gradient through ATP synthase. (7) The charge generated from H^+ exiting through ATP synthase causes a conformational change in the enzyme, converting ATP and inorganic phosphate into ATP. $NADH$ = nicotinamide adenine dinucleotide, reduced; NAD^+ = nicotinamide adenine dinucleotide, oxidized; $FADH_2$ = Flavin adenine dinucleotide, reduced; FAD = Flavin adenine dinucleotide, oxidized; e^- = electron, ADP = adenosine diphosphate, ATP = adenosine triphosphate. Original diagram adapted from Polyzos & McMurray, 2017.

1.4.2 Mitochondrial Dynamics

Mitochondrial fission, or biogenesis, is the process by which a mitochondrion undergoes fission to create new mitochondria. Biogenesis occurs in response to a stimulus, such as endurance exercise (Bruce, Kriketos, Cooney, & Hawley, 2004). Increasing the number of mitochondria through biogenesis increases the ATP output potential of the cell (Russell, Foletta, Snow, & Wadley, 2014). In contrast, mitochondrial fusion is the process of fusing mitochondria to share mtDNA, repair damaged mitochondria, or alter the efficiency of the mitochondria. In

myocytes, physical inactivity can cause an increase in mitochondrial fusion, leading to mitochondrial loss and muscle atrophy (Hoppeler & Fluck, 2003). Peroxisome proliferator-activated receptor gamma coactivator 1-alpha (PGC-1 α) and nuclear respiratory factor 1 (NRF1) are critical proteins involved in mitochondrial biogenesis in skeletal muscle (Russell et al., 2014). Although the presence of PGC-1 α in the placenta has been confirmed, its purpose and contribution to mitochondrial biogenesis in this organ have not been well defined (Jiang, Teague, Tryggestad, & Chernausk, 2017). On the other hand, NRF1 is a known activator of mitochondrial biogenesis in the placenta and is linked to the transcription of the five mitochondrial complex subunits (Scarpulla, 2008).

1.5 Physical Activity and Mitochondria

Physical activity is the most important modifiable risk factor for cardiovascular disease, diabetes mellitus, obesity, and hypertension (Warburton, Nicol, & Bredin, 2006). Increasing PA can subsequently increase physical fitness, which has an effect of decreasing all-cause mortality risk (Blair, 1996) and improves psychological wellbeing (Dunn, Trivedi, & O'Neal, 2001), body composition, and overall health (Warburton, Gledhill, & Quinney, 2001). Physical activity regulates mitochondrial quantity and quality in skeletal muscle through biogenesis and mitophagy (Yan et al., 2012). Endurance exercise leads to an increase in PGC-1 α (Baar, 2002), which upregulates biogenesis (Puigserver & Spiegelman, 2003). Endurance exercise also stimulates mitofusin-1 and mitochondrial fission 1 protein content in skeletal muscle (Perry et al., 2010), which are implicated in mitochondrial regulation through fission (Westermann, 2010). Thus, high-quality mitochondria are maintained through upregulated fusion and fission of mitochondria, through repeated bouts of endurance exercise (Cartoni et al., 2005).

Physical activity has also been shown to influence mitochondria in non-contractile tissue. Physical activity can reduce the risk of incidence and severity of non-alcoholic fatty liver disease (NAFLD), a disease caused by excess fatty acid accumulation in the liver (Church *et al.*, 2006). Animal studies have identified mitochondrial oxidation as a potential mediator between PA and hepatic protection against NAFLD. For instance, rats bred with high aerobic capacity display improved mitochondrial oxidation in the liver, which mitigates the risk and progression of liver disease (Morris *et al.*, 2017). Note that although the study by Morris *et al.* used rats that were selectively bred for high or low aerobic capacity, and thus were not engaging in PA as an independent variable, aerobic capacity is directly influenced by aerobic PA (Dehn & Bruce, 1972). Also, there is some evidence that PA can reduce oxidative stress in non-contractile tissue. In the brain, PA can improve the balance of ROS and antioxidants, thus protecting neurons from ROS-related damage and diseases like Alzheimer's disease (Bernardo *et al.*, 2016). Similarly, PA performed throughout pregnancy has been shown to increase endothelial nitric oxide synthase (eNOS) and nitric oxide (NO), and decrease ROS in term placenta (Ramírez-Vélez, Bustamante, Czerniczyniec, Aguilar De Plata, & Lores-Arnaiz, 2013). These findings indicate that mitochondria have diverse roles outside of energy production and that PA plays a part in modulating some of these roles.

Although not the focus of this thesis, it has been postulated that myokines may be responsible for the improvement of placental mitochondrial content and function. Myokines are proteins released by myocytes during physical activity that serve an endocrine function, either directly to the muscle involved in force production or other tissues in the body (Pedersen, Åkerström, Nielsen, & Fischer, 2007). Some of these myokines, such as interleukin-6 (IL-6), irisin, and SPARC have been identified in human placenta, although their specific function on

placental tissue is currently unknown (Garcés et al., 2014, Dubé, 2017). These myokines, and others that have not been introduced here may be responsible for some of the changes to non-contractile tissue seen after bouts of PA.

1.6 High-Resolution Respirometry

One way that mitochondrial function can be measured is through high-resolution respirometry (HRR). High-resolution respirometry is the measurement of oxygen consumption of freshly isolated mitochondria in real-time. The novelty of HRR is its ability to segmentally measure the ETC by examining its component protein complex activities. The Hansatech Oxygraph Plus System (OPS) (Hansatech Instruments Ltd, UK) is an instrument that measures mitochondrial oxygen consumption using HRR (Garedew, Hütter, Haffner, Gradl, & Gradl, 2005). The OPS uses a ‘Clark electrode’, an oxygen-sensing cathode that is separated from the solution chamber by a membrane permeable to molecular oxygen. The Clark electrode then detects this oxygen gas to determine the concentration of oxygen present in solution. A measurement of decreasing oxygen concentration is thought to be the result of the process of oxidative phosphorylation by the mitochondria in solution.

The OPS provides an in-depth analysis of the electron-transport chain (ETC) through substrate activation and subsequent inhibition of each protein complex in the chain individually. The process through which respiration is measured is through the addition of specific reagents to the solution in a sequence, each acting on the protein complexes of the ETC (see Figure 2 below). This sequential analysis allows for a greater ability to phenotype individual pieces of the mitochondria’s OXPHOS capacity, and, if the mitochondria exhibit dysfunction, the ability to

detect the location of the dysfunction in the ETC. The substrates, inhibitors, and uncoupler used in this protocol are listed below.

Glutamate, malate, and pyruvate are substrates involved in CI activation. Succinate is a substrate linked to CII activation. ADP is the substrate that is converted into ATP by CV, using the electrochemical gradient created by the ETC. By dispersing the electrochemical gradient, ADP facilitates state 3 respiration to occur. Carbonyl cyanide m-chlorophenyl hydrazine (CCCP) is a compound that uncouples the mitochondrial inner membrane, allowing for the artificial dispersion of the proton gradient, thus eliminating CV's function as a potential rate-limiting step for oxygen consumption. Antimycin A inhibits CIII, halting the ability of CI and CII to function. Ascorbate and N, N, N', N'-tetramethyl-p-phenylenediamine (TMPD) are substrates for CIV that skip the initial three protein complexes, allowing for measurement of CIV in isolation. Potassium cyanide (KCN) inhibits CIV, which halts the uptake of oxygen and thus stops the OPS measurement. A visual representation of the OPS analysis is shown in Figure 3.

The OPS is recognized for its sensitivity to changes in oxygen concentration with very low mitochondria yields (0.04 mg), and its resistance to oxygen leak (Gnaiger, 2001). High-resolution respirometry has been used to study human placental mitochondria (Holland, Hickey, et al., 2017; Mandò et al., 2014), however much of this research has focused on placental pathologies like pre-eclampsia, and no research to date has investigated the role of PA on placental mitochondria using HRR.

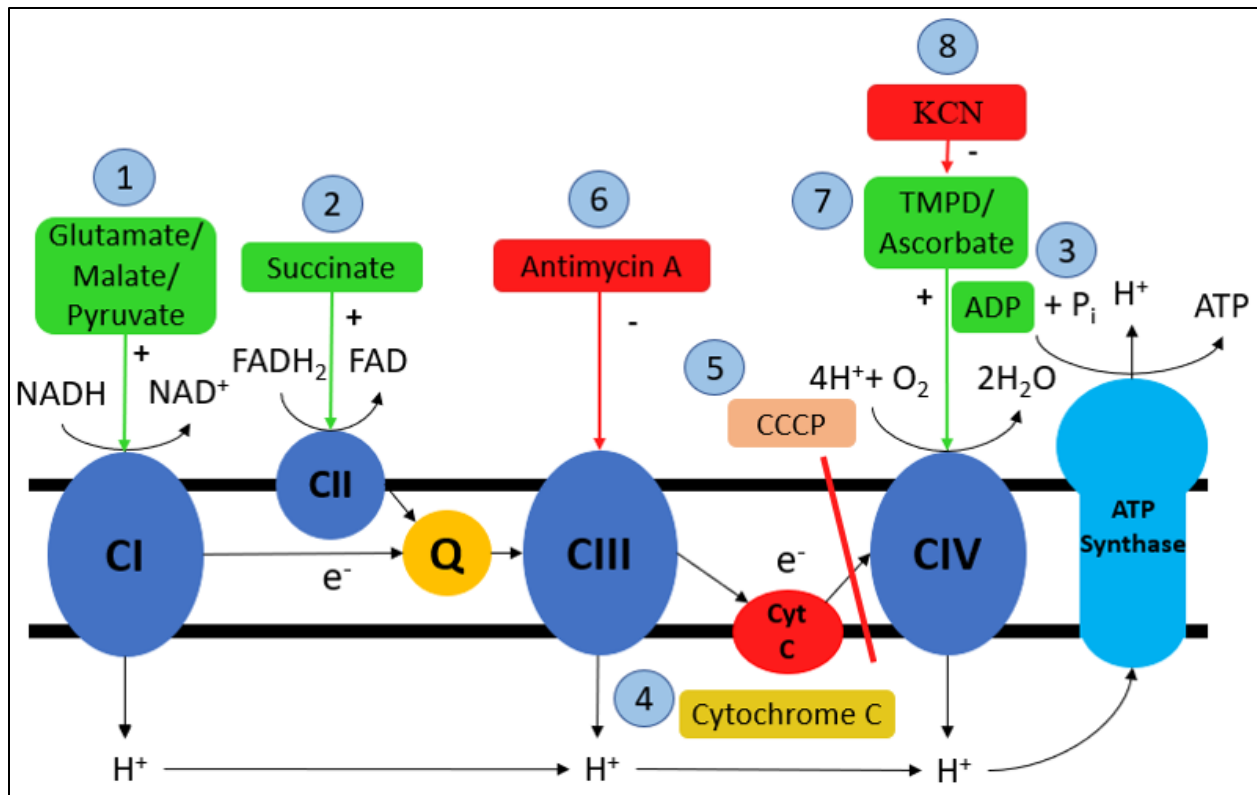

Figure 4. Diagram of SUI protocol reagents, and their effect on the electron transport chain. (1) glutamate, malate, and pyruvate stimulate complex I activity; (2) succinate stimulates complex II activity; (3) ADP acts as a substrate for ATP synthase, allowing the proton gradient to be dispersed and state III respiration to proceed; (4) cytochrome C tests mitochondrial membrane integrity; (5) CCCP uncouples the mitochondrial membrane, allowing protons to leak and ATP synthase to be bypassed; (6) antimycin A inhibits complex III; (7) ascorbate and TMPD stimulate complex IV activity; (8) KCN inhibits complex IV and halts respiration. Original diagram adapted from Polyzos & McMurray, 2017.

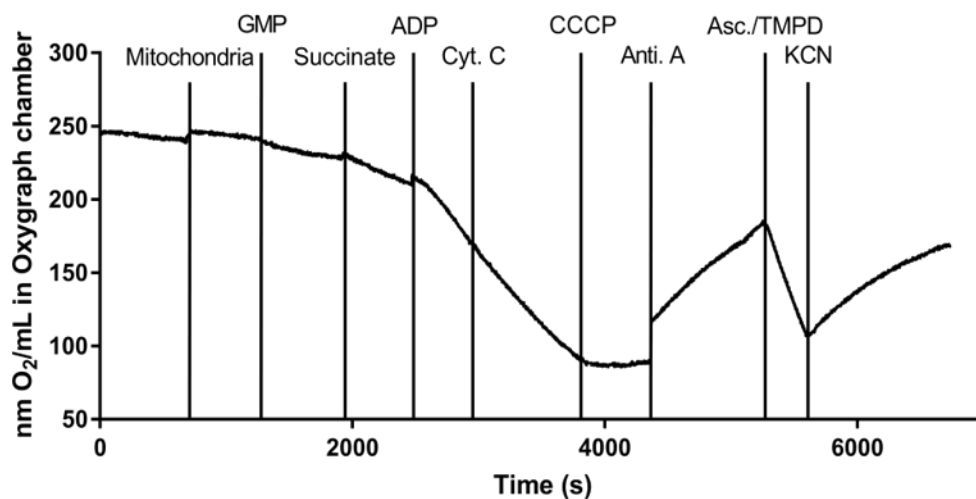

Figure 5. Example placental OPS tracing showing O₂ concentration over time during the experiment. The tracing shows the raw data from the substrate-uncoupler-inhibitor titration (SUIT) protocol from a participant in the “Active” physical activity status category. Mitochondria = isolated mitochondria added to Oxygraph chamber, GMP = glutamate + malate + pyruvate, ADP = adenosine diphosphate, Cyt. C = cytochrome C, CCCP = carbonyl cyanide m-chlorophenyl hydrazone, anti. A = antimycin A, Asc./TMPD = ascorbate + N,N,N',N'-tetramethyl-p-phenylenediamine, KCN = potassium cyanide.

1.7 Study Rationale

Physical activity promotes improved mitochondrial biogenesis and function in skeletal myocytes through direct, innervated stimulation to produce force, which promotes the activation of certain factors that contribute to mitochondrial biogenesis, such as PGC-1 α (Holloszy & Booth, 1976). This mechanism, however, does not apply to the placenta given it is not an innervated organ and does not contribute directly to PA through force production (Reilly & Russell, 1977). Thus, factors that influence mitochondrial biogenesis and function through PA are proposed to be provided indirectly, through changes in blood flow and subsequently vaso-placental shear stress, and blood content.

Given our current knowledge on the relationships between PA and both mitochondria and pregnancy, we believe there is value in extending our understanding of placenta mitochondria

and their potential relationship with maternal PA. Currently, research on placental mitochondria is almost exclusively focused on pregnancy complications such as preeclampsia or intrauterine growth restriction (Wolf, Owe, Juhl, & Hegaard, 2014). Few studies have examined placental mitochondria in healthy populations, which account for the majority of pregnancies. The studies that do address healthy populations and include PA as an exposure focus on ROS production in placenta mitochondria as a source of oxidative stress during pregnancy (Ramírez-Vélez et al., 2013). It is unclear if there are PA-related differences in mitochondrial protein content and function in placentas from otherwise healthy women.

Data published by Jauniaux et al. demonstrated that different regions of the placenta might have different onset times of maternal blood flow, as well as blood flow resistance (Jauniaux et al., 2003), suggesting that separate regions of the placenta may develop and function differently. However, despite the evidence that the placenta is heterogeneous in form and function, few studies consider regional differences when implementing their sampling methods. Examination of the placenta literature shows a variety of locations from which placenta biopsies are chosen. The majority of the literature describes samples taken only from the centre of the placenta, while some studies do not describe which region samples are taken from (Jarvenpaa et al., 2007, Herse et al., 2007). Some studies choose to sample a combination of areas from both central and peripheral regions (Soleymanlou et al., 2005, Kang et al., 2011) but treat the sample as a ‘homogenate’ or ‘pooled sample’ and do not compare sample regionality or origin in their analyses. The novelty of my study will show whether placenta regionality influences placental mitochondrial protein content and function for the first time.

1.8 Research Aims

The purpose of this study was to determine the effect of maternal mid-pregnancy PA, as well as the placental region, on mitochondrial protein content and function in term placenta. This study is the first comprehensive study to investigate mitochondrial function in healthy human placenta. For this study, mitochondrial protein content is defined as the relative quantity of mitochondrial protein complexes in the placenta, determined by western blotting. Mitochondrial function is defined as the relative rate of oxygen consumption of specific mitochondrial states within isolated mitochondria using HRR.

This study had three main aims:

Aim 1: To determine the relationship between maternal PA on mitochondrial protein content and function in the placenta.

Aim 2: To identify differences in mitochondrial protein content and function between tissue samples taken from the central region and the distal (peripheral) region of the placenta.

Aim 3: To identify differences in mitochondrial protein content and function between male and female offspring placentas.

1.9 Hypotheses

Hypothesis 1: Placentas of physically-active women will have greater mitochondrial protein content and function compared to physically-inactive women.

Hypothesis 2: Mitochondria located proximal to the insertion point of the umbilical cord (central region) will have greater access to placental bed blood flow and increased rate of oxygen

consumption, and thus will have greater mitochondrial protein content and function compared to mitochondria located distal to the insertion point (peripheral region).

Hypothesis 3: Placentas from female offspring tend to promote placental growth and development throughout pregnancy more than placentas from male offspring. Thus, placentas from female offspring will have greater mitochondrial protein content compared to placentas of male offspring.

Chapter 2 - Methods

2.1 Participants

Seventeen pregnant women participating in the PLACENTA study (CIHR MOP 142298) were recruited for this study. Participants were screened by phone to determine their eligibility for the study. Inclusion and exclusion criteria are shown in Table 1. Body mass index (BMI) was calculated as the participant's pre-pregnancy weight in kg divided by their height in metres squared. All participants gave written informed consent before participation, and ethics approval for this study was obtained from the University of Ottawa, The Ottawa Hospital (TOH), Montfort Hospital, Queensway-Carleton Hospital (QCH), and the Children's Hospital of Eastern Ontario (CHEO). This study adhered to the ethical guidelines of the Declaration of Helsinki (World Medical Association, 2013).

Table 1. Study inclusion and exclusion criteria.

Inclusion Criteria	Exclusion Criteria
Maternal age 18-40 years	Consuming alcohol, tobacco, or drugs
Pre-pregnancy BMI between 18.5-29.9 kg/m ²	Pre-pregnancy insulin treated diabetes
Gestational age less than 28 weeks	Diagnosis of fetal growth restriction or hypertensive diseases
Weight stable for at least 6 months prior to pregnancy	Untreated thyroid disease
Given medical clearance by doctor	Hypertension requiring medication
	Contraindications to exercise
	Planning to have the child adopted
	Participants who score ≥ 13 on the EPDS or who indicate that they are at risk of harming themselves
	Unable to communicate in English or French

BMI = Body mass index; EPDS = Edinburgh Postnatal Depression Scale.

2.2 Participant visits and accelerometer data capture

All participants were asked to visit the laboratory at least two times during their pregnancy (2nd and 3rd trimester, T2 and T3, respectively), with participants recruited before 16 weeks visiting the laboratory an extra time (T1). Visits occurred between gestational weeks 12-16 (T1), 24- 28 (T2), and 34-38 (T3). Participants were given an omniaxial Actical® accelerometer (Philips Respironics, Bend, OR, USA) to wear for seven days after each visit, and bouts of free-living PA were recorded during this time. The Actical® was chosen because it is a highly reliable and valid device for measuring PA (Colley et al., 2011). Participants were instructed to wear the Actical® on their hip during the day, and to only remove during bathing or swimming activities, and during sleep. Valid days of Actical® wear were defined as having at

least 10 hours of accumulated wear time. Actical® data was downloaded as counts per minute then reduced and analysed using SAS version 9.3 in accordance with the methodology described in the Canadian Health Measures Survey (R. Colley, Gorber, & Tremblay, 2010). The output of this analysis was minutes of sedentary time and light, moderate, and vigorous PA per day, based on standardized cut-points. The Canadian Physical Activity Guidelines (CPAG) and the Canadian guidelines for physical activity throughout pregnancy recommend that adults participate in at least 150 minutes of moderate-to-vigorous PA (MVPA) per week, accumulated in 10-minute bouts, so only 10-minute bouts or more of MVPA were used in the analysis of this study (Tremblay et al., 2011, Mottola et al., 2018). Participants were considered to have an “Active” PA status if their mid-pregnancy (T2) MVPA met or exceeded 150 minutes per week or 21.4 minutes per day, and those participants whose MVPA was below 150 minutes per week were considered to have an “Inactive” PA status.

2.3 Tissue collection and preparation

Human term placentas were processed on ice within 60 minutes of delivery. Eight samples, roughly two grams wet weight each, were taken from the maternal side (four samples located near the centre of the placenta, four samples located on the outer edge), avoiding the maternal layer of surface decidua (see Figure 4 for the sampling diagram). Half of the samples were flash frozen in liquid N₂ for use in Western blot analysis, while the other half were kept fresh on ice for mitochondrial isolation and high-resolution respirometry. The fresh samples were blotted on absorbent paper to remove excess blood and were suspended in 25 mL of a tris-EGTA preservation buffer on ice (9.34 mM TRIS HCl, 5.66 mM TRIS, 1 mM EGTA, 285.7 mM sucrose). These samples were transported to the laboratory on ice for further processing and analysis.

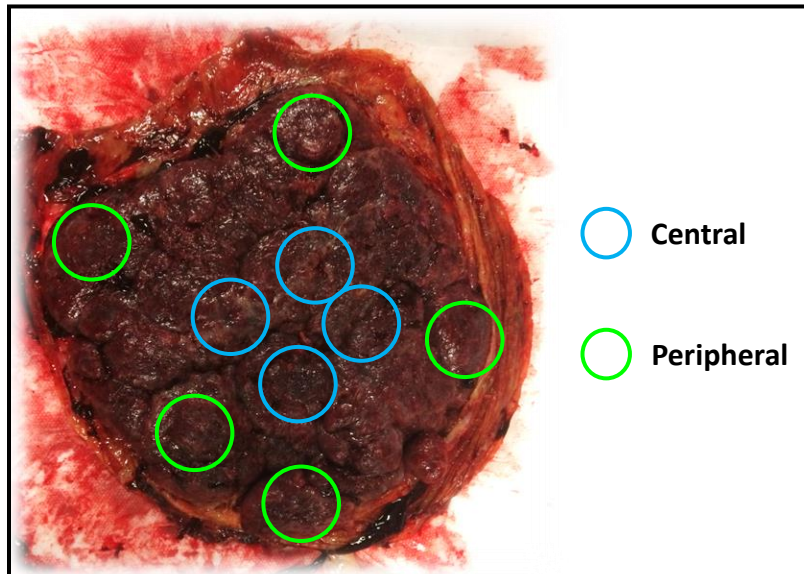

Figure 6. Placenta sampling diagram. Placenta is shown with the maternal side facing the camera. Cotyledons are circled showing possible areas for taking tissue samples. Blue circles denote “central” cotyledons of the placenta, proximal to the centre of the disk. Green circles denote “peripheral” cotyledons, distal to the centre of the disk, or close to the edge of the disk. For the sampling protocol, four central samples and four peripheral samples were randomly chosen from the maternal side of each placenta. Cotyledons with obvious necrosis, infarction, or calcification were avoided. Photo is original.

2.4 Western blots

Central and peripheral placenta tissue from 12 participants were used for this analysis. Twelve samples were used for this analysis instead of the total 17 due to methodological constraints. The primary antibody used for all blots was Total OXPHOS Human WB Antibody Cocktail (ab110411), which contains five antibodies against mitochondrial complex I (CI) subunit NDUFB8 (ab110242), mitochondrial complex II (CII) subunit 30kDa (ab14714), mitochondrial complex III (CIII) subunit Core 2 (ab14745), mitochondrial complex IV (CIV) subunit II (ab110258), and ATP synthase (CV) subunit alpha (ab14748), respectively. Flash-frozen placenta tissue was crushed into powder and kept on dry ice. Protein was then extracted from powdered tissue by homogenizing in ice-cold Radioimmunoprecipitation assay buffer, and protein was quantified using a Bradford Protein Assay (Bio-Rad). Protein lysates were prepared

in laemmli buffer and beta-mercaptoethanol for resolving by Mini-PROTEAN® TGX Stain-Free™ gel (Bio-Rad, 456-8086). On each gel, 12 central or 12 peripheral placenta samples were run against a loading control consisting of all 24 pooled samples. The resolved proteins were then transferred onto a PVDF membrane (Bio-Rad) by wet transfer method. After the protein transfer, PVDF membranes were blocked with 5% powdered milk in TBST solution for one hour at room temperature on a rocker. The membranes were incubated overnight on a shaker at 4°C with a 1:1000 dilution (in 5% powdered milk in TBST solution) of mouse monoclonal antibodies against CI subunit, CII subunit, CIII subunit Core 2, CIV subunit II, and CV subunit alpha. The blots were washed three times for five minutes each using TBST on a rocker, then incubated at room temperature with a dilution of 1:5000 (in 5% powdered milk in TBS-T solution) of Goat Anti-Mouse IgG (H + L)-HRP Conjugate (Bio-Rad, 170-6516) on a rocker. Blots were washed three times as previously described. The blots were developed using Clarity ECL Western Substrate (Bio-Rad) and imaged. Densitometry analysis of the bands was performed using Image Lab 6.0 software (Bio-Rad). Complex IV subunit II protein did not appear on the blots and thus was excluded from the analysis. Further investigation into the literature did not reveal a reason for why CIV did not work for this western blot when all of the other complexes were successfully probed using this mitochondrial antibody cocktail. Mitochondrial complex IV subunit II protein has been identified in human skeletal muscle (Samjoo et al., 2013), brain (Rice, Smith, Roberts, Perez-Costas, & Melendez-Ferro, 2014), and adipose tissue (Gómez-Serrano et al., 2017) using the same antibody as was used in this study. However, since there is currently no published research identifying mitochondrial complex IV subunit II protein in placenta tissue using this antibody, it is unknown if the antibody binds to this protein.

2.5 High-resolution respirometry

2.5.1 Mitochondrial isolation

Placenta tissue samples were weighed upon arrival at the laboratory. Tissue samples were then homogenized on ice using a Powergen 125 homogenizer (Fisherbrand, Ottawa, ON, Canada). The homogenate was centrifuged at 1000 x g for 10 minutes at 4°C. The supernatant was extracted using a syringe to avoid the fat layer formed on top of the supernatant, then the centrifuge step was repeated. The resulting supernatant was then centrifuged at 10000 x g for 10 minutes at 4°C to sediment the mitochondrial fraction. The mitochondrial pellet was resuspended in a second preservation buffer containing a lower concentration of EGTA (8.71 mM TRIS HCl, 1.54 mM TRIS, 0.05 mM EGTA, 285.7 mM sucrose), then this centrifuge step was repeated to further purify the pellet. The resulting mitochondrial pellet was suspended in 200 µL of the second preservation buffer. Protein content of the isolated mitochondria sample was assessed by a Pierce™ BCA Protein Assay (Thermo Scientific™, Waltham, MA, USA).

2.5.2 Oxygraph analysis

Mitochondrial respiration was assessed using the Hansatech Oxygraph Plus System (OPS, Hansatech Instruments Ltd, UK). The oxygraph was calibrated before each experiment. Four chambers were used: two for the mitochondria from the central tissue, and two for the mitochondria from the peripheral tissue. In each chamber, isolated mitochondria were suspended in 1 mL of respiration buffer (110 mM KCl, 5 mM K₂HPO₄, 10 mM MOPS) at a concentration of 0.5 g protein per mL of buffer at 23°C. Baseline respiration measurements of the isolated mitochondria were taken, then a SUIIT (substrate, uncoupler, inhibitor titration) protocol was followed (Figure 3). Glutamate (10 mM), pyruvate (5 mM), and malate (2.5 mM) were added to

assess CI activity in the absence of ADP. Succinate (10 mM) was added to assess CII activity in the absence of ADP. ADP (2 mM) was added to assess state III (S3) respiration. Carbonyl cyanide m-chlorophenyl hydrazone (CCCP) was added to uncouple the mitochondrial membrane and assess uncoupled S3 respiration. CCCP was added in three increments of 0.1 μ M, and the highest rate of O₂ consumption was recorded. Antimycin A (8 μ M) was added to inhibit CIII, halting S3 respiration. Ascorbate (3 mM) and N, N, N', N'-tetramethyl-p-phenylenediamine (TMPD) (0.3 mM) were added in combination to assess CIV activity. Potassium cyanide (0.6 mM) was added to inhibit CIV activity and halt respiration. Rates of change in O₂ concentration were subtracted from baseline values to reflect individual changes (for a representation of the data output from this experiment, see Figure 5).

A. Inactive participant

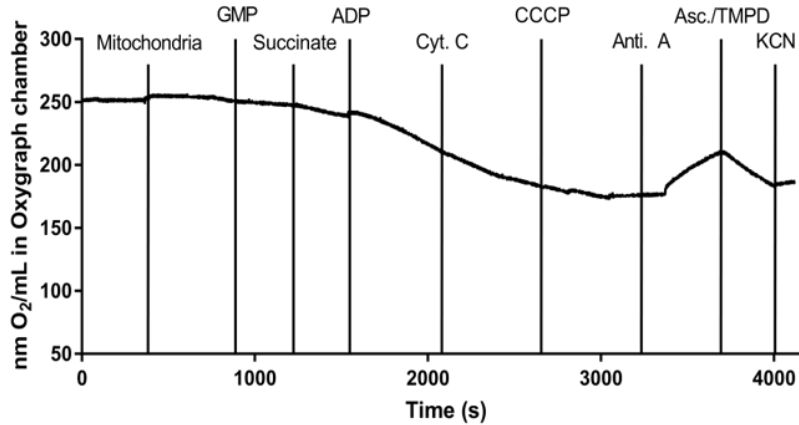

B. Active participant

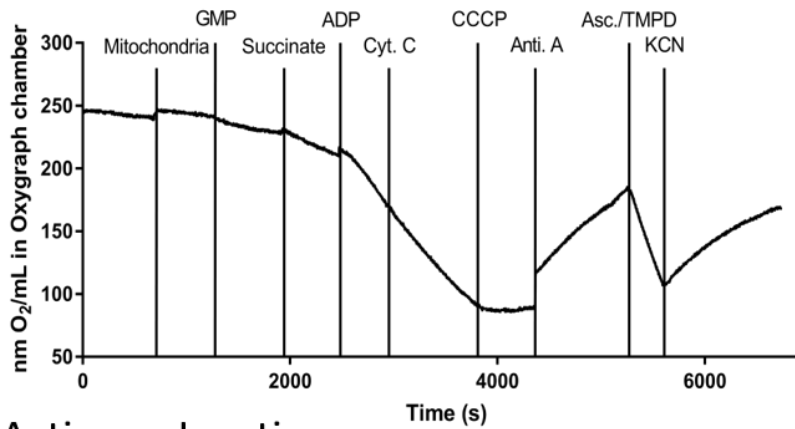

C. Active vs Inactive

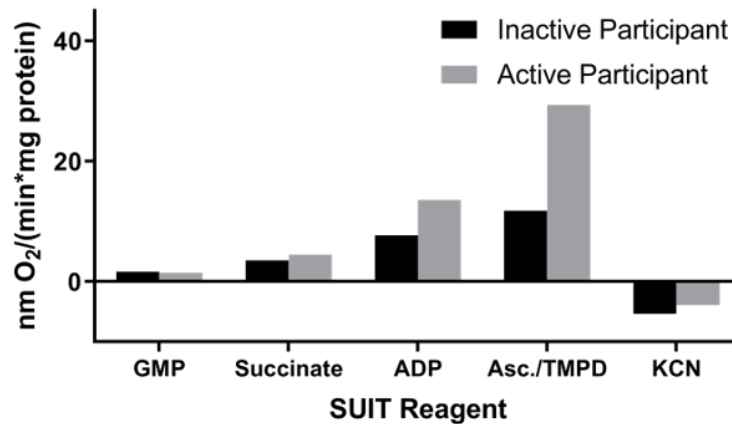

Figure 7. Oxygraph data from two individual experiments. Tracings show the raw data from the substrate-uncoupler-inhibitor titration (SUIT) protocol for two participants, (A) inactive and (B) active. (C) is the analysed results of both tracings showing the rate of oxygen flux after the addition of each SUIIT reagent. For each plot: mitochondria = isolated mitochondria added to Oxygraph chamber, GMP = glutamate + malate + pyruvate, ADP = adenosine diphosphate, cyt. C = cytochrome C, CCCP = carbonyl cyanide m-chlorophenyl hydrazone, anti. A = antimycin A, Asc./TMPD = ascorbate + N,N,N',N'-tetramethyl-p-phenylenediamine, KCN = potassium cyanide.

2.6 Statistical analyses

For all analyses, significance was set at $p < 0.05$. Data with $p < 0.1$ was reported as trending towards significance. The statistical tests used are described in detail below.

2.6.1 Effects of PA on mitochondrial protein content

Due to a large difference in group size between Active and Inactive participants for the western blot analysis (Active = 3 participants, Inactive = 9 participants) and because MVPA in the western blot analysis sample was not normally distributed, Spearman's rank-order correlations were used to assess the relationships between MVPA and mitochondrial protein content. Spearman's rank-order correlations were also used to assess the relationships between MVPA and protein content in placentas from male offspring, while Pearson's correlations were used to assess these relationships in placentas from female offspring. Complex I, CII, CIII, CV, and total protein content of placenta mitochondria from the western blot analysis were used to represent relative mitochondrial protein content. For each variable, central and peripheral measurements were presented separately.

2.6.2 Effects of PA on mitochondrial respiration

Independent samples t-tests were used to identify differences in mitochondrial function between the Active and Inactive groups. Spearman's rank-order correlations were used to assess the relationships between MVPA and mitochondrial function in placentas from male offspring, while Pearson's correlations were used to assess these relationships in placentas from female offspring. The variables used to represent mitochondrial function were CI, CII, and CIV leak respiration, as well as state 3 respiration, from the OPS analysis.

2.6.3 Regional differences in the placenta

Paired sample t-tests were used to identify regional differences of mitochondrial function and protein content in placentas from the total sample pool as well as from male and female offspring, respectively. Complex I, CII, CIII, CV, and total relative protein content were compared between central and peripheral tissue. Central and peripheral measurements of CI, CII, and CIV respiration, as well as S3 respiration, were also compared.

2.6.4 Analyses by offspring sex

Differences in mitochondrial protein content and function between male and female offspring placentas were assessed using independent samples t-tests.

Chapter 3 - Results

3.1 Study Population Demographics

Table 2 shows participant characteristics for the Active and Inactive groups for the western blot analysis. Table 3 shows participant characteristics for the Active and Inactive groups for the OPS analysis. For both analyses, all participant groups were similar in age, pre-pregnancy weight, pre-pregnancy BMI, gestational age at birth, placental weight, offspring birth weight, and offspring birth length (all p-values > 0.05). By design, the Active group for both the OPS and the western blot analyses had significantly higher MVPA minutes per day compared to the Inactive group ($p < 0.01$). The MVPA minutes per day of the female offspring group were not significantly different than the male offspring group for both analyses (p-values > 0.05).

Table 2. Study population demographics for the mitochondrial protein content analysis.

	Inactive (n = 9)	Active (n = 3)	Female Offspring (n = 7)	Male Offspring (n = 5)
<u>Participant</u>				
Maternal age (years)	34.0 ± 3.2	32.3 ± 0.6	33.6 ± 3.4	33.6 ± 2.1
Pre-pregnancy weight (kg)	63.6 ± 10.5	59.7 ± 3.7	59.2 ± 5.6	67.5 ± 11.8
Pre-pregnancy BMI (kg/m ²)	22.7 ± 2.5	21.4 ± 1.2	21.6 ± 1.6	23.5 ± 2.9
MVPA during 2 nd trimester (min/day)	4.1 ± 5.7	29.2 ± 6.9**	13.4 ± 13.2	6.0 ± 11.8
Gestational age at birth (weeks)	40.0 ± 1.0	39.5 ± 1.1	40.1 ± 0.9	39.7 ± 1.2
Placenta weight (g)	499 ± 117	536 ± 94	465 ± 61	575 ± 130
<u>Offspring</u>				
Birth weight (kg)	3.18 ± 0.33	3.36 ± 0.32	3.10 ± 0.16	3.42 ± 0.42
Birth length (cm)	49.8 ± 2.2	51.1 ± 1.9	49.2 ± 1.5	51.5 ± 2.3

Values are presented as mean ± SD. Inactive = low physical activity group (<21.4 minutes of MVPA/day; Active = high physical activity group (≥21.4 minutes of MVPA/day); BMI = body mass index; MVPA = moderate-to-vigorous physical activity. ** indicates a significant difference between groups, p < 0.01.

Table 3. Participant and offspring characteristics for the mitochondrial respiration analysis.

	Inactive (n = 11)	Active (n = 6)	Female Offspring (n = 11)	Male Offspring (n = 6)
<u>Participant</u>				
Maternal age (years)	32.8 ± 3.2	33 ± 2.8	32.5 ± 3.2	34.2 ± 2.3
Pre-pregnancy weight (kg)	63.8 ± 10.1	62.1 ± 7.9	62.6 ± 8.1	65.0 ± 12.2
Pre-pregnancy BMI (kg/m ²)	23.2 ± 2.5	22.5 ± 2.9	23.1 ± 2.6	22.9 ± 2.9
MVPA during 2 nd trimester (min/day)	7.2 ± 6.8	40 ± 17.3**	15.6 ± 15.9	9.3 ± 13.3
Gestational age at birth (weeks)	40.3 ± 1.1	39.7 ± 0.8	40.1 ± 1.0	39.8 ± 1.1
Placenta weight (g)	502 ± 97	479 ± 126	465 ± 68	550 ± 131
<u>Offspring</u>				
Birth weight (kg)	3.27 ± 0.35	3.33 ± 0.36	3.20 ± 0.31	3.47 ± 0.40
Birth length (cm)	50.4 ± 2.3	50 ± 2.7	50.0 ± 2.4	51.4 ± 2.1

Values are presented as mean ± SD. Inactive = low physical activity group (<21.4 minutes of MVPA/day; Active = high physical activity group (≥21.4 minutes of MVPA/day); BMI = body mass index; MVPA = moderate-to-vigorous physical activity. ** indicates a significant difference between groups, p < 0.01.

3.2 Analysis by MVPA

3.2.1 Effects of MVPA on mitochondrial protein content

Western blot images are shown in Figure 6. There was a significant positive correlation between MVPA and total relative protein in peripheral tissue, $r_s = 0.599$, $p = 0.040$ (Figure 7).

There was a significant positive correlation between MVPA and relative protein of CII in peripheral tissue, $r_s = 0.683$, $p = 0.014$ (Figure 8). A correlation between MVPA and relative

protein of CI in central tissue trends towards significance, $r_s = 0.556$, $p = 0.060$ (Figure 9). A correlation between MVPA and relative protein of CII in central tissue trends towards significance, $r_s = 0.543$, $p = 0.087$ (Figure 8). No correlations between MVPA and CIII, CV, or total relative protein approached significance in central tissue, and no correlations between MVPA and CI, CIII, or CV relative protein approached significance in peripheral tissue (all p-values > 0.1).

In the placentas of female offspring, there was a significant correlation between MVPA and CV relative protein in peripheral tissue, $r_p = 0.783$, $p = 0.037$ (Figure 10). There was a correlation between MVPA and total relative protein in peripheral tissue from female offspring placentas that trends towards significance, $r_p = 0.746$, $p = 0.054$. No correlations approaching significance were found between MVPA and relative content of any protein in central tissue, or between MVPA and CI, CII, or CIII relative protein in peripheral tissue (all p-values > 0.1).

In male offspring placentas, there was a correlation between MVPA and CII relative protein in central tissue that trends towards significance, $r_s = 0.872$, $p = 0.054$. There was also a correlation between MVPA and CII relative protein in peripheral tissue from male offspring placentas that trends towards significance, $r_s = 0.872$, $p = 0.054$. No correlations approaching significance were found between MVPA and CI, CIII, CV, or total relative protein in central tissue, or between MVPA and CI, CIII, CV, or total relative protein in peripheral tissue (all p-values > 0.1).

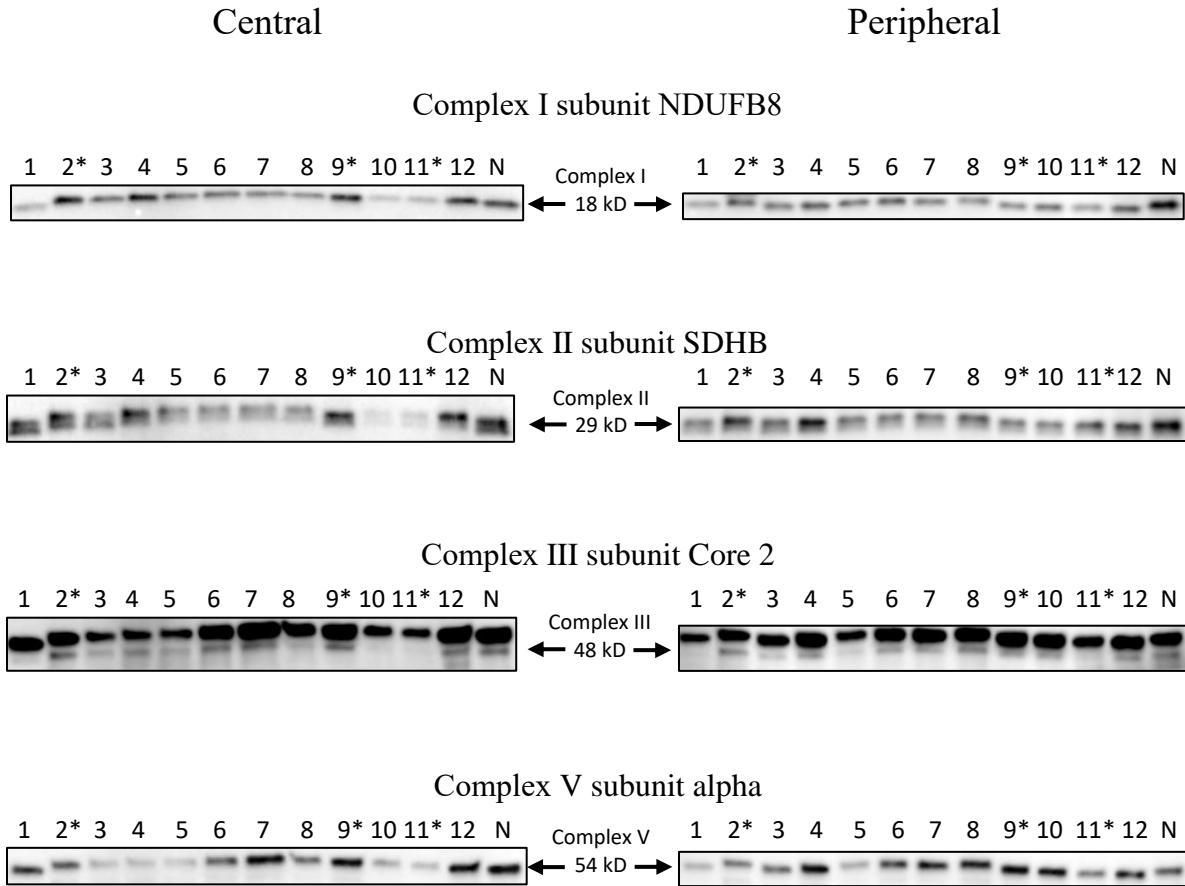

Figure 8. Gel images from western blot analysis. Western blot analysis was performed on mitochondrial proteins complex I subunit NDUFB8, complex II subunit SDHB, complex III subunit Core 2, and complex V subunit alpha. Two blots were performed, one from tissue located in the center of the placenta, the other from tissue located in the peripheral of the placenta. Lanes 1-12 are protein samples from individual participants. Bands on an individual gel were normalized to their respective stain-free image lanes, and were then normalized to the loading control, consisting of identical samples of protein from all 24 samples in both gels. * indicates a participant from the “Active” physical activity status group.

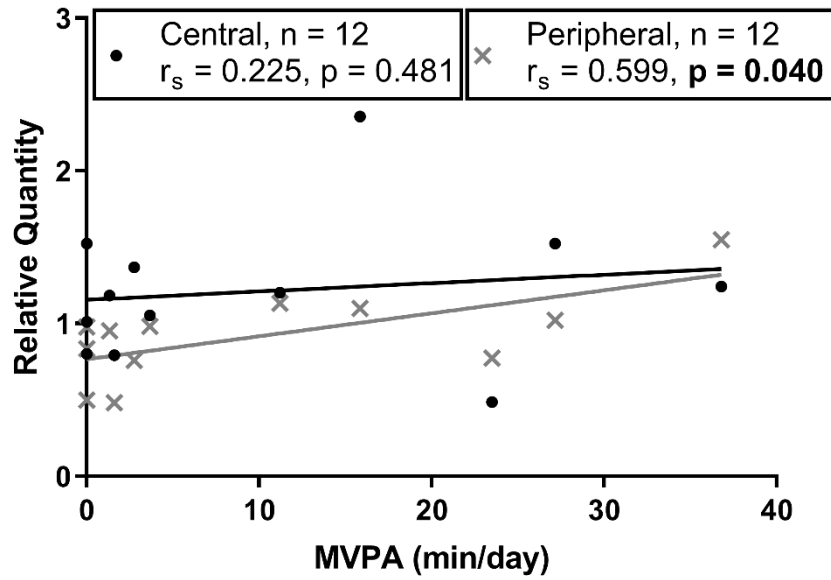

Figure 9. The relationship between average daily moderate-to-vigorous physical activity during the 2nd trimester and total relative protein quantity in the placenta by region. Bolded p-value indicates a significant relationship between MVPA and total relative quantity of protein in peripheral placenta tissue.

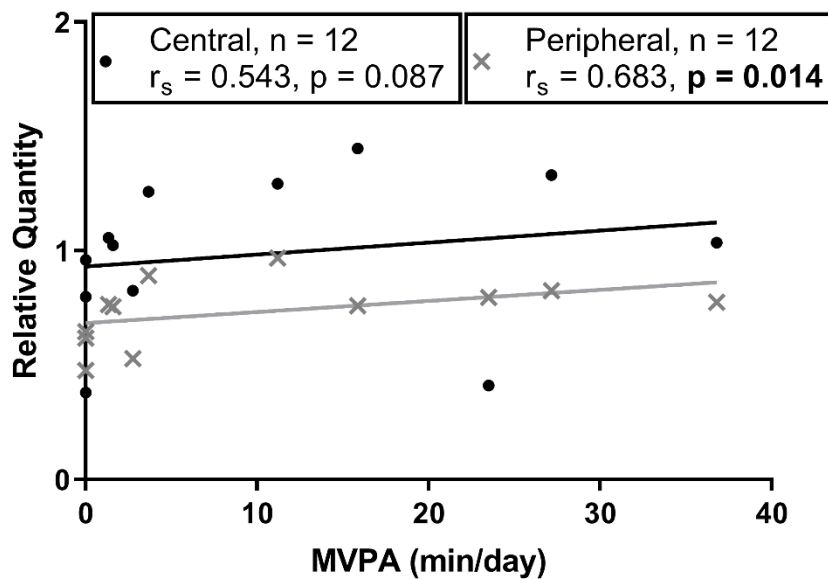

Figure 10. The relationship between average daily moderate-to-vigorous physical activity during the 2nd trimester and complex II protein quantity in the placenta by region. Bolded p-value indicates a significant relationship between MVPA and relative quantity of complex II protein in peripheral placenta tissue.

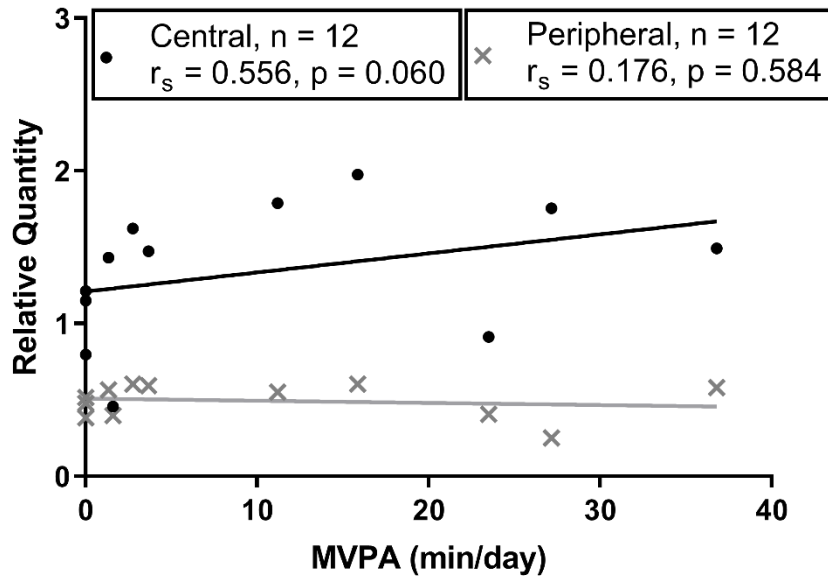

Figure 11. The relationship between average daily moderate-to-vigorous physical activity during the 2nd trimester and complex I protein quantity in the placenta by region.

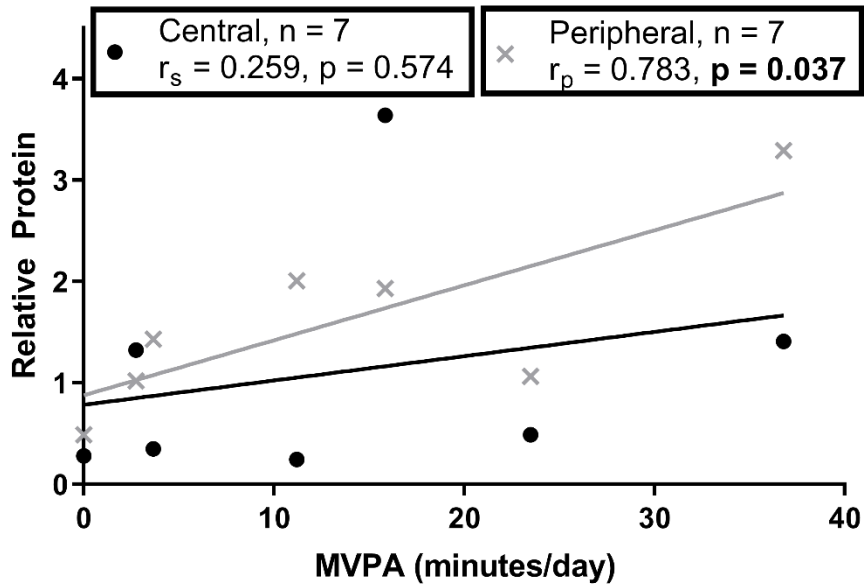

Figure 12. The relationship between average daily moderate-to-vigorous physical activity during the 2nd trimester and complex V protein quantity in placentas of female offspring by region. Bolded p-value indicates a significant relationship between MVPA and relative quantity of complex II protein in peripheral placenta tissue.

3.2.2 Effects of MVPA on mitochondrial respiration

State 3 respiration in central tissue samples from Active participants was significantly higher than Inactive participants, $t(15) = 2.737$, $p = 0.015$ (Figure 11). Complex I activity in was higher in central tissue for Active participants compared to Inactive participants, but this trend was not significant, $t(15) = 2.058$, $p = 0.057$. No differences approaching significance were found between MVPA and CII or CIV activity in central tissue, or between MVPA and any functional outcomes in peripheral tissue. There were also no correlations between MVPA and any measures of mitochondrial function for male or female offspring placentas that approached significance (all p -values > 0.1).

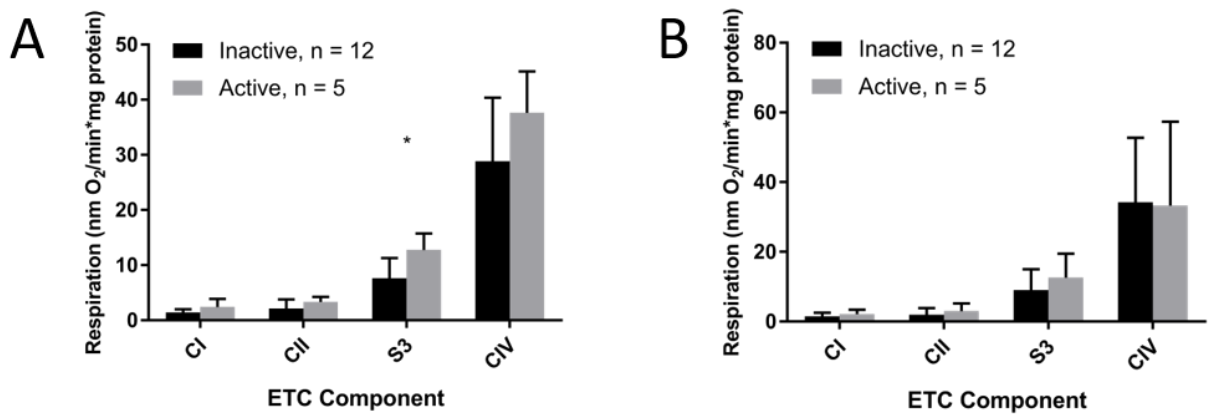

Figure 13. Mitochondrial respiration data from central and peripheral placenta tissue, grouped by physical activity status. Panels show mean \pm SD change in O_2 per minute, per mg of isolated mitochondria protein for each component of the electron transport chain between Active and Inactive participants in central (A) and peripheral (B) tissue. ETC = electron transport chain, CI = complex I, CII = complex II, S3 = state 3 respiration, CIV = complex IV. * indicates a significant difference between groups, $p < 0.05$.

3.3 Analysis by Placenta Region

3.3.1 Regional differences in mitochondrial protein content

Relative protein of CI was significantly higher in central tissue samples compared to peripheral tissue samples, $t(11) = 6.941$, $p < 0.001$ (Figure 12). Relative protein of CII was significantly higher in central tissue compared to peripheral tissue, $t(11) = 3.204$, $p = 0.008$. Total relative protein was significantly higher in central tissue compared to peripheral tissue, $t(10) = 2.304$, $p = 0.042$. No differences were found for relative protein of CIII or CV between central and peripheral tissue that approached significance (all p -values > 0.1).

In placentas of female offspring, relative protein of CI was significantly higher in central tissue compared to peripheral tissue, $t(6) = 8.070$, $p < 0.001$ (Figure 13). Relative protein of CII was higher in central tissue compared to peripheral tissue in female offspring placentas, but this difference was not significant, $t(6) = 2.036$, $p = 0.088$. There were no differences approaching significance in CIII, CV, and total relative protein between central and peripheral tissue from female offspring placentas (all p -values > 0.1).

In placentas of male offspring, relative protein of CI was significantly higher in central tissue compared to peripheral tissue, $t(4) = 2.867$, $p = 0.046$ (Figure 13). Total relative protein was significantly higher in central tissue from male offspring placentas compared to peripheral tissue, $t(4) = 3.141$, $p = 0.035$. Relative protein of CII was higher in central tissue from male offspring placentas compared to peripheral tissue, but this difference was not significant, $t(4) =$

2.625, $p = 0.058$. There were no differences in relative protein of CIII or CV between central and peripheral tissue of male offspring placentas that approached significance (both p -values > 0.1).

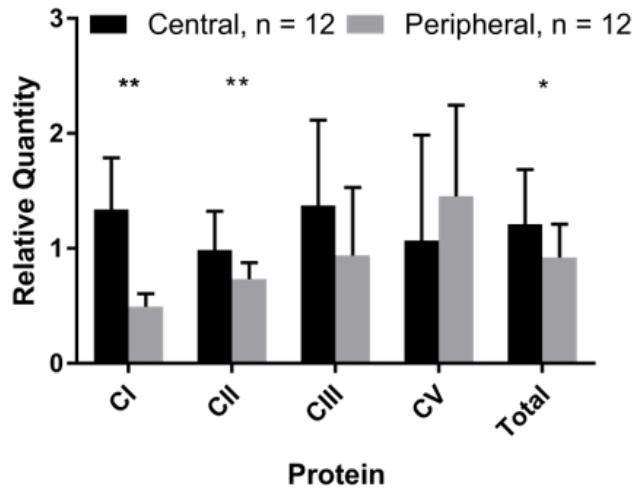

Figure 14. Comparison of placental mitochondrial protein content by placental region. Differences in relative CI, CII, CIII, CV, and total protein quantity between central and peripheral placental regions are shown. CI = complex I, CII = complex II, CIII = complex III, CV = complex V, Total = average of CI, CII, CIII, and CV. * indicates a significant difference between groups, $p \leq 0.05$. ** indicates a significant difference between groups, $p \leq 0.01$.

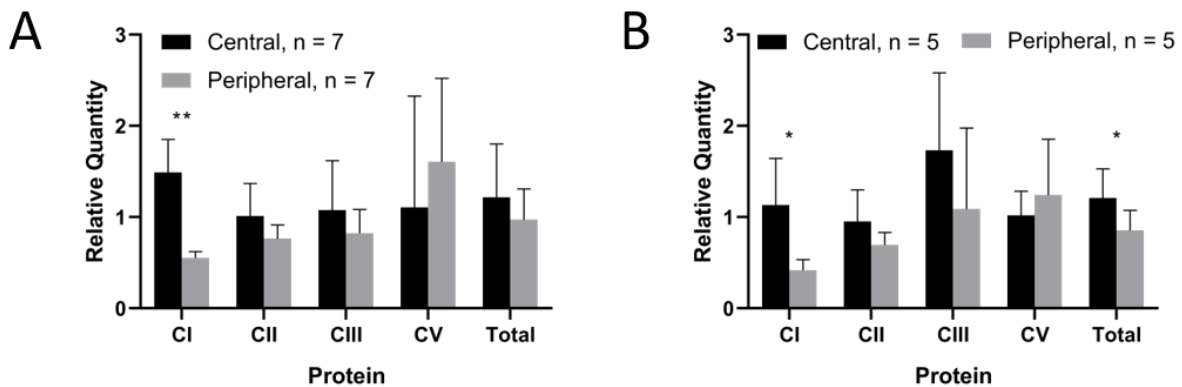

Figure 15. Comparison of mitochondrial protein content in placentas of female and male offspring by placental region. Differences in relative CI, CII, CIII, CV, and total protein quantity between central and peripheral placental regions in female offspring (A) and male offspring (B) are shown. CI = complex I, CII = complex II, CIII = complex III, CV = complex V, Total = average of CI, CII, CIII, and CV. ** indicates a significant difference between groups, $p \leq 0.01$.

3.3.2 Regional differences in mitochondrial function

There were no differences in CI, CII, and CIV respiration, as well as S3 respiration between central and peripheral tissue that approached significance (all p-values > 0.1, Figure 14). There were also no differences that approached significance in any measure of mitochondrial function between central and peripheral tissue, from male or female offspring placentas (all p-values > 0.1, Figure 15).

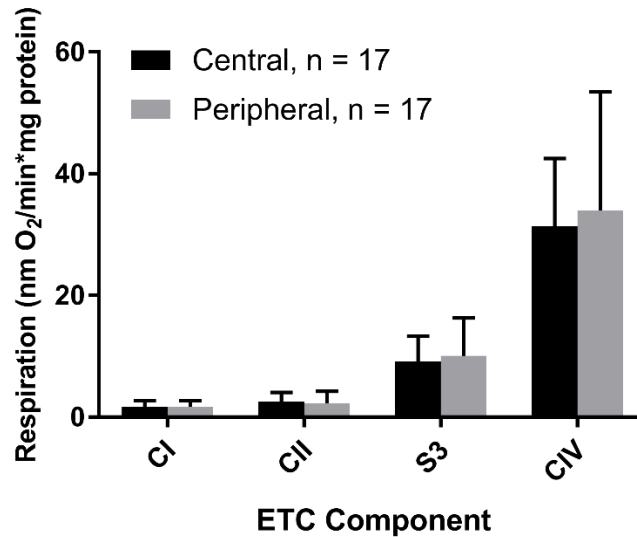

Figure 16. Comparison of mitochondrial respiration data by placental region. Differences in function of CI, CII, CIV, and S3 respiration between central and peripheral placental regions are shown. CI = complex I, CII = complex II, CIII = complex III, CV = complex V, Total = average of CI, CII, CIII, and CV.

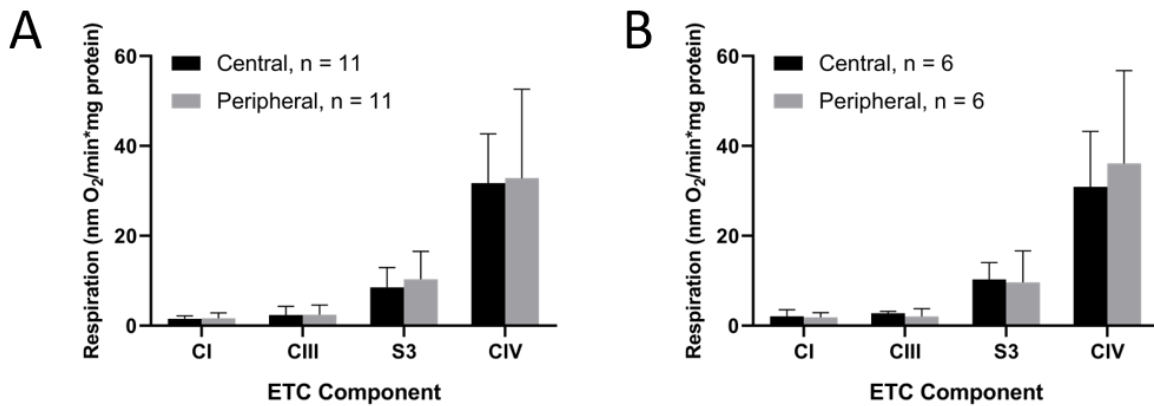

Figure 17. Comparison of mitochondrial respiration data in placentas of female and male offspring by placental region. Differences in function of CI, CII, CIV, and S3 respiration between central and peripheral placental regions in female offspring (A) and male offspring (B) are shown. CI = complex I, CII = complex II, CIII = complex III, CV = complex V, Total = average of CI, CII, CIII, and CV.

3.4 Analyses by Offspring Sex

3.4.1 Differences in mitochondrial protein content between offspring sexes

Female offspring placentas had significantly higher relative CI protein in peripheral tissue than male offspring placentas, $t(10) = 2.503$, $p = 0.031$ (Figure 16). No differences approaching significance were found in CII, CIII, CV, or total relative protein in peripheral tissue between male and female placentas, and no differences approaching significance were found in any relative protein content in central tissue between male and female placentas (all p -values > 0.1).

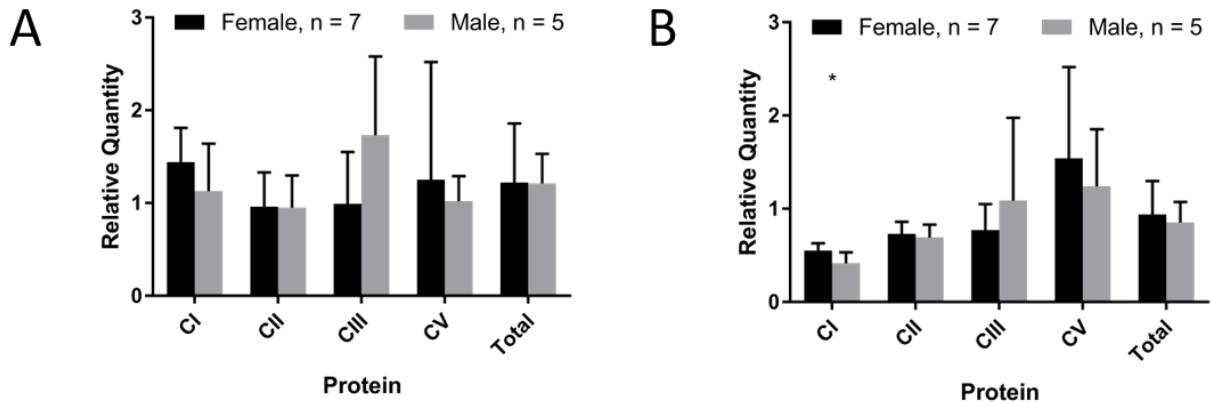

Figure 18. Comparison of mitochondrial protein content by offspring sex. Differences in relative CI, CII, CIII, CV, and total protein quantity in central (A) and peripheral (B) tissue between male and female offspring placentas are shown. CI = complex I, CII = complex II, CIII = complex III, CV = complex V, Total = average of CI, CII, CIII, and CV. * indicates a significant difference between groups, $p \leq 0.05$.

3.4.2 Differences in mitochondrial function between offspring sexes

No differences were found in any measures of mitochondrial function for central or peripheral tissue between male and female offspring placentas that approached significance (all p-values > 0.1, Figure 17).

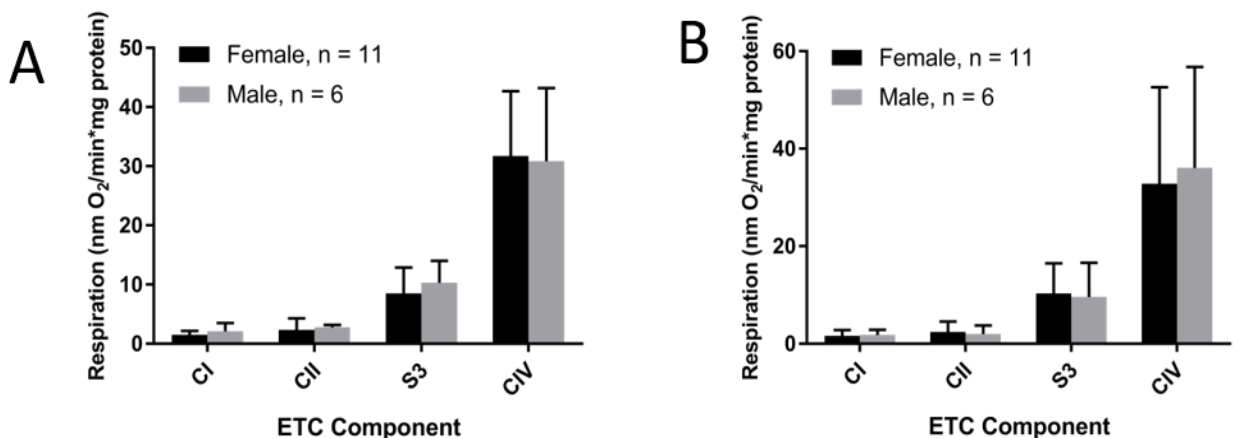

Figure 19. Comparison of mitochondrial respiration data by offspring sex. Differences in function of CI, CII, CIV, and S3 respiration in central (A) and peripheral (B) tissue between male and female offspring placentas are shown. CI = complex I, CII = complex II, CIII = complex III, CV = complex V, Total = average of CI, CII, CIII, and CV.

Chapter 4 – Discussion

4.1 Effect of PA on mitochondrial protein content & function

The primary aim of this study was to identify relationships between mid-pregnancy maternal PA and mitochondrial protein content and function in the placenta. Physical activity in early and mid-pregnancy is associated with mid-pregnancy placental growth estimated by B-mode ultrasound, specifically in metabolically-active tissue like intermediate and terminal villi (Clapp et al., 2000). We anticipated that participants who had engaged in more PA in mid-pregnancy would have a similar increase in the growth of metabolically-active tissue in the placenta, and thus have increased mitochondrial function and more mitochondrial protein compared to women who had engaged in less PA in mid-pregnancy. My results show that there was a significant positive relationship between MVPA and both CII and total relative protein in peripheral tissue (Figure 6 & 7), as well as positive relationships between MVPA and both CI and CII relative protein in central tissue that trend towards significance (Figure 7 & 8). These results appear to be in line with the hypothesis and suggest that mid-pregnancy MVPA has some relationship with mitochondrial protein content in the placenta, particularly in peripheral areas. Increasing the frequency of PA during pregnancy has been associated with decreasing placental weight (Hilde, Eskild, Owe, Bø, & Bjelland, 2017, Ramírez-Vélez et al., 2013). Interestingly, the study by Ramírez-Vélez et al. also indicated that fetal birth weight did not change with increasing maternal PA, which indicates a greater placental efficiency, or ability to grow and sustain more fetal tissue per unit of placental tissue. Increased placental efficiency may indicate greater mitochondrial density to maintain fetal growth, which is consistent with our findings.

Figure 6 shows an interesting interaction between MVPA and total relative protein content in central and peripheral placenta tissue. In participants with lower MVPA values, total relative protein content in central tissue is higher on average than in peripheral tissue. However, in participants with higher MVPA values, this difference in protein content between central and peripheral tissue disappears, which may indicate that mid-pregnancy MVPA has a greater effect on mitochondrial protein content in peripheral regions of the placenta. Since PA has been associated with greater blood flow to the placenta (Clapp, 2003), and that the central areas of the placenta have been shown to have greater vascularization than peripheral placentas (Jauniaux et al., 2003), perhaps the effect of increased in PA-associated blood flow is more pronounced in peripheral placenta tissue compared to central tissue, which would thus promote increased mitochondrial content in those peripheral areas.

State 3 respiration is characterized by the addition of ADP to a suspension of mitochondria in the presence of excess substrates, which allows for the synthesis of ATP coupled with the dissipation of the proton gradient that speeds up the respiration process. State 3 respiration is equivalent to the maximal rate of oxidative phosphorylation in living cells and is, therefore, the most biologically-relevant respiration measure of this study, despite the artificial environment (Chance & Williams, 1955, Palmeira & Moreno, 2012). In this study, S3 respiration was significantly higher in the Active group compared to the Inactive group when analyzing mitochondrial isolated from the central region of the placenta (Figure 10). This result is in concordance with the hypothesis and suggests that there is a relationship between mid-pregnancy MVPA on mitochondrial function in central placental tissue, where higher MVPA is associated with higher mitochondrial function. A study by Jackson et al. showed that women who participated in a moderate exercise program until mid- pregnancy had a higher proportion of

villous tissue to non-villous tissue in the placenta compared to non-exercising women, which was further increased if participation in the exercise program persisted until the end of pregnancy (Jackson et al., 1995). This PA-associated increase in villous tissue, along with a potential increase in angiogenic factors (Clapp et al., 2000), suggests a greater capability for nutrient transport in the placenta. Since ATP production from mitochondria is involved in active nutrient transport in the placenta, these factors may be related to the differences in mitochondrial S3 respiration between Active and Inactive participants in this study.

A study by Holland *et al.* measured mitochondrial function using HRR but employed a different technique from my study (Holland, Hickey, et al., 2017). Instead of isolating mitochondria from fresh placenta tissue for use in the OPS, the Holland group permeabilized fresh placenta cells with saponin, maintaining their structure and integrity but allowing the SUT reagents and oxygen to enter and exit the cells. Although cell permeabilization is thought to more closely reflect the *in vivo* environment compared to direct mitochondrial isolation, the latter method is more established in placental literature (Gasnier et al., 1993, Olivera & Meigs, 1975). In the future, these two techniques should be compared prospectively to determine their differences when studying placenta mitochondria.

4.2 Regional differences in the placenta

The secondary aim of this study was to identify regional differences in placenta mitochondrial protein content and function. By mid-pregnancy, resistance to maternal blood flow is lower in the central region compared to the peripheral region (Jauniaux et al., 2003), so I predicted that participants would have increased mitochondrial protein content and function in the central region of the placenta compared to the peripheral region due to increased blood flow

(Jauniaux et al., 2003). In keeping with this hypothesis, there was a significantly higher protein content of CI, CII, and total protein in central tissue samples compared to peripheral tissue samples (Figure 11). These protein results suggest that there are more mitochondria in term placenta tissue on the maternal side closer to the centre of the disk compared to close to the edge of the disk. There is some evidence to suggest that mitochondrial content is closely paired with blood flow in muscle tissue (Terjung, Zarzeczny, & Yang, 2002). However, placenta tissue may have different mechanisms for mitochondrial biogenesis and angiogenesis compared to muscle. Thus, the mechanism for this difference in mitochondrial proteins is currently unknown. These results confirm that the placenta is indeed a heterogeneous organ and stresses the importance of regional sampling considerations when studying placenta biology and function.

4.3 Offspring Sex

Male and female offspring fetoplacental units have been shown to have different growth patterns, especially under conditions of environmental stress. Female offspring tend to conserve placental growth during adverse events, thereby restricting fetal growth but maintaining an optimal environment for the fetus (Eriksson et al., 2010). Males, on the other hand, respond to adverse events by prioritizing fetal over placental growth (Clifton, 2010). Male offspring-pregnancies are at a greater risk for GDM, pre-eclampsia, umbilical cord abnormalities, acute fetal distress, and intrauterine fetal death, while female offspring-pregnancies are at a greater risk for the development of intrauterine growth restriction (Di Renzo et al., 2007). Because of these differences in growth strategies, I hypothesized that there would be a stronger correlation between maternal MVPA and mitochondrial protein, as well as greater mitochondrial protein content overall, in placentas of female offspring compared to male offspring.

There was a significant positive correlation between MVPA and CV relative protein content (Figure 9), and a positive trending correlation between MVPA and total relative protein content, in peripheral tissue from female offspring placentas. In male offspring placentas, there was a positive trending correlation between MVPA and CII relative protein content in both central and peripheral tissues, but no correlations between MVPA and CV or total relative protein content. Finally, CI relative protein content in peripheral tissue was significantly higher in female offspring placentas compared to male offspring placentas (Figure 15). These results indicate that there may be differences in male and female placental development that contribute to different mitochondrial protein content and function; though these results should be considered with caution. Although there is evidence showing differential growth strategies between male and female offspring, little is known about the structural or functional differences of the placenta between sexes at the biological level in healthy pregnancies (Clifton, 2010). Moreover, the differences between sexes were quite variable, which could be due to the low sample size and statistical power of these results. Despite these limitations, future placental mitochondrial research should consider evaluating offspring sexes separately.

4.4 Mechanism of the effect of PA on the placenta

The mechanism by which PA may affect placenta mitochondria has not been established; however, based on the current knowledge of the interactions of the placenta within the maternal body, we posit that the mechanism could be due to vascular or endocrine changes to the placenta (or a combination of both). A study by Clapp et al. demonstrated that acute bouts of PA were associated with a redirection of blood flow away from the fetoplacental unit, thereby decreasing the oxygen availability for the fetus and placenta for the duration of the activity (Clapp, 2003). Although this phenomenon has not been directly observed yet, these episodes of intermittent

hypoxia are thought to trigger a sympathetic response from the fetoplacental unit to release angiogenic factors that may promote new vessel formation, thereby increasing placental perfusion volume and increase the growth of functional tissue in the placenta (Clapp *et al.*, 2000). Sustaining PA throughout pregnancy to allow this sympathetic response to perpetuate may upregulate mitochondrial biogenesis and increase mitochondrial protein content. The second proposed mechanism is that myokines, which are proteins or peptides released by skeletal muscle during physical activity that exert endocrine effects, may have endocrine effects on placental tissue to upregulate mitochondrial biogenesis (Pedersen *et al.*, 2007). These myokines have been suggested to facilitate some of the beneficial effects of physical activity on the body and aid in preventing chronic disease (Petersen & Pedersen, 2005). A review by Dubé *et al.* has identified myokines such as interleukin-6 and irisin in the placenta, which may have a potential impact on placental function and fetal growth (Dubé, Aguer, Adamo, & Bainbridge, 2017). Recently, preliminary data from our group show that another exercise-induced myokine, SPARC, has been shown to improve placental invasion early in pregnancy (Dubé, 2017). We propose that one or multiple of these myokines released during physical activity may signal for the placenta to upregulate mitochondrial biogenesis. These myokines could target peroxisome proliferator-activated receptor gamma coactivator 1-alpha (PGC-1 α), a critical gene involved in mitochondria biogenesis, in placental tissue. Irisin, in particular, has been shown to increase PGC1- α activity of both myocytes and adipocytes in mice, though its role in human tissue, particularly the placenta, is currently unknown (Schnyder & Handschin, 2015). The mechanisms outlined above could work independently or together to upregulate mitochondrial content in the placenta.

Although the assessment of mitochondrial complex protein content is considered valuable due to their direct involvement in the electron transport chain, it should be noted that there are at

least 1200 different proteins in the mitochondria (Yang et al., 2013). These proteins have roles in the numerous functions of the mitochondria, which cannot all be accounted for in this study.

Mitochondrial function, however, measures the capacity of the mitochondria as whole organelles to respire and should be considered the most important measure of this study.

To our knowledge, this is the first study to explore the relationship of objectively-measured maternal PA on directly-measured term placenta mitochondrial protein content and function. The main strength of this study lies in the reporting of objective measurements of PA and of placental mitochondrial protein content and function. Self-reported physical activity is not as accurate as objectively/prospectively-measured PA (Evenson & Wen, 2010), and pregnant women have been found to over-report their physical activity using a self-report questionnaire when compared to directly-measured PA using an Actical® accelerometer (Brett, Wilson, Ferraro, & Adamo, 2015). Thus, we recruited our study participants prospectively and used accelerometers to objectively measure their PA in real-time. Furthermore, great care was taken to minimize protein degradation and optimize the quality of my term placenta samples. This included collecting my placenta samples on ice within an hour of birth, with the OPS analysis performed immediately to minimize any protein and RNA degradation that could have occurred (Fajardy et al., 2009). For these reasons, I am confident that the variables assessed in this study were as accurate as was feasible.

4.5 Limitations

An observational, exploratory study involving pregnant human participants comes with inherent limitations. For instance, the length of human pregnancy caused a delay of 3-7 months from the time of recruitment to the time of data collection, depending on the participant's

gestational age at the outset. The natural timeline of this study is further complicated by the reliance on birthing unit staff to promptly contact our research team upon admittance of our participants to the various hospitals or birthing centres (five locations in total). In some cases, we were unable to proceed with the OPS analysis due to delays in communication from the birthing unit staff, which caused the sample size to be further reduced. The difficulties associated with this prospective approach, coupled with the short duration of an MSc. degree, restricted the number of samples that could be included in the analyses of this study. Since the effect of PA on mitochondrial protein content and function has yet to be studied, determining an appropriate sample size *a priori* was not possible. However, from this analysis, I have calculated appropriate sample sizes for adequate statistical power that are shown in Appendix C. Now with a better estimation of sample sizes required to observe differences in these analyses, future study designs involving placenta mitochondrial protein content and function will be able to perform analyses with adequate statistical power.

It is worth noting that only mid-pregnancy (T2) values were used for the PA analyses. This is because only 33% of the participants completed an early pregnancy (T1) lab visit, and late pregnancy (T3) PA measures were unfit to be used as the participants' MVPA values decreased significantly from T2, with only 3 participants being in the "Active" range of MVPA at T3 (Figure 6). This observation is in agreement with other research that found that pregnant individuals often decrease their physical activity levels or replace higher intensity activities with lower ones – especially in the third trimester (Evenson & Wen, 2010, Poudevigne & O'Connor, 2006). Despite the fact that participants' MVPA was highest at T2, my sample pool was largely physically-inactive: 12 out of 17 participants did not meet the 2019 Canadian guidelines for physical activity throughout pregnancy (Mottola et al., 2018). Future research on PA and

pregnancy should consider using more than 2-3 time points to measure PA to better estimate whole-pregnancy PA and should recruit more participants that engage in higher amounts of PA during pregnancy.

Due to the nature of this study, only women who were experiencing healthy or non-complicated pregnancies were included. As such, all the samples included in this study were from vaginal deliveries and thus were exposed to different durations of labour before the birth of the offspring. A review by Burton et al. cautions against the use of vaginally-delivered placentas for respirometry and protein analyses (Burton & Fowden, 2012). Compared to delivery by caesarean section, vaginal delivery is known to increase oxidative stress to the placenta and fetus, which may lead to different mitochondrial outcomes that are not as representative of the *in vivo* environment (Hung et al., 2011). There is also evidence that suggests that gene expression may be altered by active labour (Sitras, Paulssen, Gronaas, Vartun, & Acharya, 2008; Lager et al., 2014). As well, some of the participants in this study were induced (meaning their labour was stimulating using oxytocin), and some elected for analgesia (i.e., an epidural); however, we were unable to access this information within our outlined study ethics so it is unclear if labour length or medications could impact mitochondrial function or protein content in the placenta after delivery. Ideally, the variability caused by labour length and medications would have been removed by recruiting only participants undergoing scheduled cesarean sections, thus removing variability associated with labour and standardizing medications across all samples; however, given the prospective design of the study, this method of recruitment was not an option.

4.6 Conclusion

This exploratory study investigated if mitochondrial protein content and function in term human placentas were affected by physical activity during pregnancy, or by differences in placental region. This is the first comprehensive study looking at mitochondrial function in the placenta. The results indicated that there was higher mitochondrial protein in tissue samples taken from the centre of the placental disk compared to samples from the peripheral, and that there was a significant positive association between PA and protein content in samples taken from the peripheral. Moreover, S3 respiration was significantly higher in central samples taken from participants who met the Canadian guideline for physical activity throughout pregnancy compared to participants who did not meet the guideline. However, there were no significant associations between mitochondrial function and placental region. These results suggest that increased PA during pregnancy is associated with increased mitochondrial protein content in peripheral regions of the placenta, and increased mitochondrial function in central regions. Complex I protein from peripheral placenta tissue samples was higher in placentas from female offspring compared to placentas from male offspring, which may support the notion that male and female offspring grow differently in the womb. We propose that the increases in mitochondrial protein content and function may be associated with the fetal sympathetic response to reduced blood perfusion during exercise, or by the endocrine effect of myokines on the placenta, or both. Future research involving placenta mitochondria should consider regional differences when sampling the placenta, as well as offspring sexual dimorphism into their study design. This study was the first to examine the potential contributions of PA to placenta mitochondrial function and has thus provided new avenues for future work involving physical activity in the healthy pregnant population.

References

- Aviram, A., Hod, M., & Yogev, Y. (2011). Maternal obesity: Implications for pregnancy outcome and long-term risks-A link to maternal nutrition. *International Journal of Gynecology and Obstetrics*, *115*(SUPPL. 1), S6–S10. [https://doi.org/10.1016/S0020-7292\(11\)60004-0](https://doi.org/10.1016/S0020-7292(11)60004-0)
- Baar, K. (2002). Adaptations of skeletal muscle to exercise: rapid increase in the transcriptional coactivator PGC-1. *The FASEB Journal*, *16*(14), 1879–1886. <https://doi.org/10.1096/fj.02-0367com>
- Barker, D. J. (1990). The fetal and infant origins of adult disease. *BMJ*, *301*(6761), 1111–1111. <https://doi.org/10.1136/bmj.301.6761.1111>
- Barker, D. J. P. (2000). In utero programming of cardiovascular disease. In *Theriogenology* (Vol. 53, pp. 555–574). Elsevier. [https://doi.org/10.1016/S0093-691X\(99\)00258-7](https://doi.org/10.1016/S0093-691X(99)00258-7)
- Bernardo, T. C., Marques-Aleixo, I., Beza, J., Oliveira, P. J., Ascensão, A., & Magalhães, J. (2016). Physical Exercise and Brain Mitochondrial Fitness: The Possible Role Against Alzheimer's Disease. *Brain Pathology*, *26*(5), 648–663. <https://doi.org/10.1111/bpa.12403>
- Blair, S. N. (1996). Influences of Cardiorespiratory Fitness and Other Precursors on Cardiovascular Disease and All-Cause Mortality in Men and Women. *JAMA: The Journal of the American Medical Association*, *276*(3), 205. <https://doi.org/10.1001/jama.1996.03540030039029>
- Bragoszewski, P., Turek, M., & Chacinska, A. (2017). Control of mitochondrial biogenesis and function by the ubiquitin-proteasome system. *Open Biology*, *7*(4).

<https://doi.org/10.1098/rsob.170007>

Brett, K. E., Wilson, S., Ferraro, Z. M., & Adamo, K. B. (2015). Self-report Pregnancy Physical Activity Questionnaire overestimates physical activity. *Canadian Journal of Public Health, 106*(5), e297–e302. <https://doi.org/10.17269/CJPH.106.4938>

Brown, W. V., Fujioka, K., Wilson, P. W. F., & Woodworth, K. A. (2009). Obesity: Why be concerned? *American Journal of Medicine, 122*(4 SUPPL. 1), S4-11.
<https://doi.org/10.1016/j.amjmed.2009.01.002>

Bruce, C. R., Kriketos, A. D., Cooney, G. J., & Hawley, J. A. (2004). Disassociation of muscle triglyceride content and insulin sensitivity after exercise training in patients with Type 2 diabetes. *Diab Tologia, 47*(1), 23–30. <https://doi.org/10.1007/s00125-003-1265-7>

Burton, G. J., & Fowden, A. L. (2012). Review: The placenta and developmental programming: Balancing fetal nutrient demands with maternal resource allocation. In *Placenta* (Vol. 33, pp. S23-7). Elsevier. <https://doi.org/10.1016/j.placenta.2011.11.013>

Cartoni, R., Léger, B., Hock, M. B., Praz, M., Crettenand, A., Pich, S., ... Russell, A. P. (2005). Mitofusins 1/2 and ERR α expression are increased in human skeletal muscle after physical exercise. *The Journal of Physiology, 567*(1), 349–358.
<https://doi.org/10.1113/jphysiol.2005.092031>

Chance, B., & Williams, G. R. (1955). Respiratory enzymes in oxidative phosphorylation. I. Kinetics of oxygen utilization. *The Journal of Biological Chemistry, 217*(1), 383–393.
<https://doi.org/10.1111/j.1460-9568.2009.07042.x> Qualitatively

Church, T. S., Kuk, J. L., Ross, R., Priest, E. L., Biltoff, E., & Blair, S. N. (2006). Association of

Cardiorespiratory Fitness, Body Mass Index, and Waist Circumference to Nonalcoholic Fatty Liver Disease. *Gastroenterology*, *130*(7), 2023–2030.

<https://doi.org/10.1053/j.gastro.2006.03.019>

Clapp, J. F. (2003). The effects of maternal exercise on fetal oxygenation and fetoplacental growth. In *European Journal of Obstetrics Gynecology and Reproductive Biology* (Vol. 110, pp. S80–S85). [https://doi.org/10.1016/S0301-2115\(03\)00176-3](https://doi.org/10.1016/S0301-2115(03)00176-3)

Clapp, J. F., Kim, H., Burciu, B., & Lopez, B. (2000). Beginning regular exercise in early pregnancy: Effect on fetoplacental growth. *American Journal of Obstetrics and Gynecology*, *183*(6), 1484–1488. <https://doi.org/10.1067/mob.2000.107096>

Clifton, V. L. (2010). Review: Sex and the Human Placenta: Mediating Differential Strategies of Fetal Growth and Survival. *Placenta*, *31*(SUPPL.), S33-9. <https://doi.org/10.1016/j.placenta.2009.11.010>

Colley, R. C., Garrigué, D., Janssen, I., Craig, C. L., Clarke, J., & Tremblay, M. S. (2011). Physical activity of Canadian adults: accelerometer results from the 2007 to 2009 Canadian Health Measures Survey. *Health Rep*, *22*(1), 7–14. <https://doi.org/10.1016/j.yspm.2011.03.006>

Colley, R., Gorber, S. C., & Tremblay, M. S. (2010). Quality control and data reduction procedures for accelerometry-derived measures of physical activity. *Health Reports / Statistics Canada, Canadian Centre for Health Information = Rapports Sur La Santé / Statistique Canada, Centre Canadien d'information Sur La Santé*, *21*(1), 63–69. <https://doi.org/82-003-X>

Cornell, B. (2016). Placenta. Retrieved May 29, 2019, from <http://ib.bioninja.com.au>

- Cross, J. C., & Mickelson, L. (2006, May). Nutritional influences on implantation and placental development. *Nutrition Reviews*. <https://doi.org/10.1301/nr.may.S12-S18>
- Dabelea, D., Hanson, R. L., Lindsay, R. S., Pettitt, D. J., Imperatore, G., Gabir, M. M., ... Knowler, W. C. (2000). Intrauterine exposure to diabetes conveys risks for type 2 diabetes and obesity: A Study of Discordant Sibships. *Diabetes*, *49*(12), 2208–2211. <https://doi.org/10.2337/diabetes.49.12.2208>
- Davenport, M. H., Ruchat, S. M., Poitras, V. J., Jaramillo Garcia, A., Gray, C. E., Barrowman, N., ... Mottola, M. F. (2018, November 1). Prenatal exercise for the prevention of gestational diabetes mellitus and hypertensive disorders of pregnancy: A systematic review and meta-analysis. *British Journal of Sports Medicine*. BMJ Publishing Group Ltd and British Association of Sport and Exercise Medicine. <https://doi.org/10.1136/bjsports-2018-099355>
- Dehn, M. M., & Bruce, R. A. (1972). Longitudinal variations in maximal oxygen intake with age and activity. *J Appl Physiol*, *33*(6), 805–807. <https://doi.org/10.1152/jappl.1972.33.6.805>
- Di Renzo, G. C., Rosati, A., Sarti, R. D., Cruciani, L., & Cutuli, A. M. (2007). Does fetal sex affect pregnancy outcome? *Gender Medicine*, *4*(1), 19–30. [https://doi.org/10.1016/S1550-8579\(07\)80004-0](https://doi.org/10.1016/S1550-8579(07)80004-0)
- Dubé, C. (2017). *The Effect of Exercise-Induced Myokines on Placental Health and Function (Unpublished master's thesis)*.
- Dubé, C., Aguer, C., Adamo, K., & Bainbridge, S. (2017). A role for maternally derived myokines to optimize placental function and fetal growth across gestation. *Applied Physiology, Nutrition, and Metabolism*, *42*(5), 459–469. <https://doi.org/10.1139/apnm->

- Dunn, A. L., Trivedi, M. H., & O'Neal, H. A. (2001). Physical activity dose-response effects on outcomes of depression and anxiety. *Medicine and Science in Sports and Exercise*, 33(Supplement), S587–S597. <https://doi.org/10.1097/00005768-200106001-00027>
- Eriksson, J. G., Kajantie, E., Osmond, C., Thornburg, K., & Barker, D. J. P. (2010). Boys live dangerously in the womb. *American Journal of Human Biology*, 22(3), 330–335. <https://doi.org/10.1002/ajhb.20995>
- Evenson, K. R., & Wen, F. (2010). National trends in self-reported physical activity and sedentary behaviors among pregnant women: NHANES 1999-2006. *Preventive Medicine*, 50(3), 123–128. <https://doi.org/10.1016/j.ypmed.2009.12.015>
- Fajardy, I., Moitrot, E., Vambergue, A., Vandersippe-Millot, M., Deruelle, P., & Rousseaux, J. (2009). Time course analysis of RNA stability in human placenta. *BMC Molecular Biology*, 10. <https://doi.org/10.1186/1471-2199-10-21>
- Ferraro, Z. M., Gaudet, L., & Adamo, K. B. (2012, February). The potential impact of physical activity during pregnancy on maternal and neonatal outcomes. *Obstetrical and Gynecological Survey*. <https://doi.org/10.1097/OGX.0b013e318242030e>
- Fowden, A. L., Forhead, A. J., Coan, P. M., & Burton, G. J. (2008). The placenta and intrauterine programming. In *Journal of Neuroendocrinology* (Vol. 20, pp. 439–450). Blackwell Publishing Ltd. <https://doi.org/10.1111/j.1365-2826.2008.01663.x>
- Garcés, M. F., Peralta, J. J., Ruiz-Linares, C. E., Lozano, A. R., Poveda, N. E., Torres-Sierra, A. L., ... Ea-m, G. (2014). Irisin Levels During Pregnancy and Changes Associated With the

Development of Preeclampsia. *J Clin Endocrinol Metab*, 99, 2113–2119.

<https://doi.org/10.1210/jc.2013-4127>

Garedew, A., Hütter, E., Haffner, B., Gradl, P., & Gradl, L. (2005). High-resolution
Respirometry for the Study of Mitochondrial Function in Health and Disease . The
OROBOROS Oxygraph-2k. *11th Congress Eu. Shock Soc.*, 107–111. Retrieved from
<http://citeseerx.ist.psu.edu/viewdoc/download?doi=10.1.1.578.1453&rep=rep1&type=pdf>

Gasnier, F., Rousson, R., Lermé, F., Vaganay, E., Louisot, P., & Gateau-Roesch, O. (1993). Use
of Percoll gradients for isolation of human placenta mitochondria suitable for investigating
outer membrane proteins. *Analytical Biochemistry*, 212(1), 173–178.

<https://doi.org/10.1006/abio.1993.1309>

Gilbert, J. S., & Nijland, M. J. (2008). Sex differences in the developmental origins of
hypertension and cardiorenal disease. *AJP: Regulatory, Integrative and Comparative
Physiology*, 295(6), R1941–R1952. <https://doi.org/10.1152/ajpregu.90724.2008>

Gnaiger, E. (2001). Bioenergetics at low oxygen: Dependence of respiration and phosphorylation
on oxygen and adenosine diphosphate supply. In *Respiration Physiology* (Vol. 128, pp.
277–297). [https://doi.org/10.1016/S0034-5687\(01\)00307-3](https://doi.org/10.1016/S0034-5687(01)00307-3)

Gómez-Serrano, M., Camafeita, E., López, J. A., Rubio, M. A., Bretón, I., García-Consuegra, I.,
... Peral, B. (2017). Differential proteomic and oxidative profiles unveil dysfunctional
protein import to adipocyte mitochondria in obesity-associated aging and diabetes. *Redox
Biology*, 11, 415–428. <https://doi.org/10.1016/j.redox.2016.12.013>

Gunderson, E. P., & Abrams, B. (2000). Epidemiology of gestational weight gain and body
weight changes after pregnancy. *Epidemiologic Reviews*, 22(2), 261–274.

<https://doi.org/10.1093/oxfordjournals.epirev.a018001>

Harding, J. (2001). The nutritional basis of the fetal origins of adult disease. *International Journal of Epidemiology*, 30(1), 15–23. <https://doi.org/10.1093/ije/30.1.15>

Hatefi, Y. (1985). The Mitochondrial Electron Transport System and Oxidative Phosphorylation. *Annual Review of Biochemistry*, 54(1), 1015–69.

<https://doi.org/10.1146/annurev.bi.54.070185.005055>

Herse, F., Dechend, R., Harsem, N. K., Wallukat, G., Janke, J., Qadri, F., ... Staff, A. C. (2007). Dysregulation of the circulating and tissue-based renin-angiotensin system in preeclampsia. In *Hypertension* (Vol. 49, pp. 604–611).

<https://doi.org/10.1161/01.HYP.0000257797.49289.71>

Hilde, G., Eskild, A., Owe, K. M., Bø, K., & Bjelland, E. K. (2017). Exercise in pregnancy: an association with placental weight? *American Journal of Obstetrics and Gynecology*, 216(2), 168.e1-168.e9. <https://doi.org/10.1016/j.ajog.2016.10.018>

Holland, O., Dekker Nitert, M., Gallo, L. A., Vejzovic, M., Fisher, J. J., & Perkins, A. V. (2017, June). Review: Placental mitochondrial function and structure in gestational disorders. *Placenta*. <https://doi.org/10.1016/j.placenta.2016.12.012>

Holland, O., Hickey, A., Alvsaker, A., Moran, S., Hedges, C., Chamley, L., & Perkins, A. (2017). Changes in mitochondrial respiration in the human placenta over gestation. *Placenta*, 65(0), 41–49. <https://doi.org/10.1016/j.placenta.2017.06.011>

Holloszy, J. O., & Booth, F. W. (1976). Biochemical Adaptations to Endurance Exercise in Muscle. *Annual Review of Physiology*, 38(1), 273–291.

<https://doi.org/10.1146/annurev.ph.38.030176.001421>

Hoppeler, H., & Fluck, M. (2003). Plasticity of skeletal muscle mitochondria: structure and function. *Med Sci Sports Exerc*, *35*(1), 95–104.

<https://doi.org/10.1249/01.MSS.0000043292.99104.12>

Hull, H. R., Thornton, J. C., Ji, Y., Paley, C., Rosenn, B., Mathews, P., ... Gallagher, D. (2011). Higher infant body fat with excessive gestational weight gain in overweight women. *American Journal of Obstetrics and Gynecology*, *205*(3), 211.e1-211.e7.

<https://doi.org/10.1016/j.ajog.2011.04.004>

Hung, T. H., Chen, S. F., Hsieh, T. T. ang, Lo, L. M., Li, M. J., & Yeh, Y. L. (2011). The associations between labor and delivery mode and maternal and placental oxidative stress. *Reproductive Toxicology*, *31*(2), 144–150. <https://doi.org/10.1016/j.reprotox.2010.11.009>

Jackson, M. R., Gott, P., Lye, S. J., Knox Ritchie, J. W., & Clapp, J. F. (1995). The effects of maternal aerobic exercise on human placental development: Placental volumetric composition and surface areas. *Placenta*, *16*(2), 179–191. [https://doi.org/10.1016/0143-4004\(95\)90007-1](https://doi.org/10.1016/0143-4004(95)90007-1)

Jansson, T., & Powell, T. L. (2007). Role of the placenta in fetal programming: underlying mechanisms and potential interventional approaches. *Clinical Science*, *113*(1), 1–13. <https://doi.org/10.1042/CS20060339>

Jarvenpaa, J., Vuoristo, J. T., Savolainen, E. R., Ukkola, O., Vaskivuo, T., & Ryyanen, M. (2007). Altered expression of angiogenesis-related placental genes in pre-eclampsia associated with intrauterine growth restriction. *Gynecological Endocrinology*, *23*(6), 351–355. <https://doi.org/10.1080/09513590701350291>

Jauniaux, E., Hempstock, J., Greenwold, N., & Burton, G. J. (2003). Trophoblastic oxidative stress in relation to temporal and regional differences in maternal placental blood flow in normal and abnormal early pregnancies. *American Journal of Pathology*, *162*(1), 115–125. [https://doi.org/10.1016/S0002-9440\(10\)63803-5](https://doi.org/10.1016/S0002-9440(10)63803-5)

Jiang, S., Teague, A. M., Tryggestad, J. B., & Chernausk, S. D. (2017). Role of microRNA-130b in placental PGC-1 α /TFAM mitochondrial biogenesis pathway. *Biochemical and Biophysical Research Communications*, *487*(3), 607–612. <https://doi.org/10.1016/j.bbrc.2017.04.099>

Johnsson, I. W., Haglund, B., Ahlsson, F., & Gustafsson, J. (2015). A high birth weight is associated with increased risk of type 2 diabetes and obesity. *Pediatric Obesity*, *10*(2), 77–83. <https://doi.org/10.1111/ijpo.230>

Kang, J. H., Song, H., Yoon, J. A., Park, D. Y., Kim, S. H., Lee, K. J., ... Cha, D. H. (2011). Preeclampsia leads to dysregulation of various signaling pathways in placenta. *Journal of Hypertension*, *29*(5), 928–936. <https://doi.org/10.1097/HJH.0b013e328344a82c>

Krebs, H. A., & Johnson, W. A. (1937). Metabolism of ketonic acids in animal tissues. *Biochemical Journal*, *31*(4), 645–660. <https://doi.org/10.1042/bj0310645>

Krueger, H., Krueger, J., & Koot, J. (2015). Variation across Canada in the economic burden attributable to excess weight, tobacco smoking and physical inactivity. *Canadian Journal of Public Health*, *106*(4), e171–e177. <https://doi.org/10.17269/CJPH.106.4994>

Lager, S., Aye, I. L. M. H., Gaccioli, F., Ramirez, V. I., Jansson, T., & Powell, T. L. (2014). Labor inhibits placental mechanistic target of rapamycin complex 1 signaling. *Placenta*, *35*(12), 1007–12. <https://doi.org/10.1016/j.placenta.2014.10.006>

- Lau, D. C. W., Douketis, J. D., Morrison, K. M., Hramiak, I. M., Sharma, A. M., & Ur, E. (2007). 2006 Canadian clinical practice guidelines on the management and prevention of obesity in adults and children. *Canadian Medical Association Journal*, *176*(8), s1–s13. <https://doi.org/10.1503/cmaj.061409>
- Mandò, C., De Palma, C., Stampalija, T., Anelli, G. M., Figus, M., Novielli, C., ... Cetin, I. (2014). Placental mitochondrial content and function in intrauterine growth restriction and preeclampsia. *American Journal of Physiology. Endocrinology and Metabolism*, *306*(4), E404-13. <https://doi.org/10.1152/ajpendo.00426.2013>
- Medical Dictionary. (2011). Placental membrane separating the blood in the fetal capillaries from the maternal blood in the intervillous space. Retrieved from https://medicine.academic.ru/139719/placental_membrane
- Medicine, I. of, & Council, N. R. (2009). *Weight Gain During Pregnancy: Reexamining the Guidelines*. (A. L. Taktine & K. M. Rasmussen, Eds.), *Institute of Medicine of the National Academies*. National Academies Press (US). <https://doi.org/10.17226/12584>
- Morris, E. M., McCain, C. S., Allen, J. A., Gastecki, M. L., Koch, L. G., Britton, S. L., ... Thyfault, J. P. (2017). Aerobic capacity mediates susceptibility for the transition from steatosis to steatohepatitis. *Journal of Physiology*, *595*(14), 4909–4926. <https://doi.org/10.1113/JP274281>
- Mottola, M. F., Davenport, M. H., Ruchat, S. M., Davies, G. A., Poitras, V. J., Gray, C. E., ... Zehr, L. (2018a, November). 2019 Canadian guideline for physical activity throughout pregnancy. *British Journal of Sports Medicine*. BMJ Publishing Group Ltd and British Association of Sport and Exercise Medicine. <https://doi.org/10.1136/bjsports-2018-100056>

- Mottola, M. F., Davenport, M. H., Ruchat, S. M., Davies, G. A., Poitras, V. J., Gray, C. E., ... Zehr, L. (2018b, November 1). 2019 Canadian guideline for physical activity throughout pregnancy. *British Journal of Sports Medicine*. BMJ Publishing Group Ltd and British Association of Sport and Exercise Medicine. <https://doi.org/10.1136/bjsports-2018-100056>
- Murtaugh, M. A., Jacobs Jr., D. R., Moran, A., Steinberger, J., & Sinaiko, A. R. (2003). Relation of birth weight to fasting insulin, insulin resistance, and body size in adolescence. *Diabetes Care*, 26(1), 187–192. <https://doi.org/10.2337/diacare.26.1.187>
- Ochner, C. N., Tsai, A. G., Kushner, R. F., & Wadden, T. A. (2015, April 1). Treating obesity seriously: When recommendations for lifestyle change confront biological adaptations. *The Lancet Diabetes and Endocrinology*. Elsevier. [https://doi.org/10.1016/S2213-8587\(15\)00009-1](https://doi.org/10.1016/S2213-8587(15)00009-1)
- Ogata, T., & Yamasaki, Y. (1997). Ultra-high-resolution scanning electron microscopy of mitochondria and sarcoplasmic reticulum arrangement in human red, white, and intermediate muscle fibers. *Anatomical Record*, 248(2), 214–223. [https://doi.org/10.1002/\(SICI\)1097-0185\(199706\)248:2<214::AID-AR8>3.0.CO;2-S](https://doi.org/10.1002/(SICI)1097-0185(199706)248:2<214::AID-AR8>3.0.CO;2-S)
- Olivera, A. A., & Meigs, R. A. (1975). Mitochondria from human term placenta. I. Isolation and assay conditions for oxidative phosphorylation. *BBA - Bioenergetics*, 376(3), 426–435. [https://doi.org/10.1016/0005-2728\(75\)90164-4](https://doi.org/10.1016/0005-2728(75)90164-4)
- Olson, C. M., & Strawderman, M. S. (2003). Modifiable behavioral factors in a biopsychosocial model predict inadequate and excessive gestational weight gain. *Journal of the American Dietetic Association*, 103(1), 48–54. <https://doi.org/10.1053/jada.2003.50001>
- Palmeira, C. M., & Moreno, A. J. (2012). *Mitochondrial Bioenergetics - Methods and protocols*.

<https://doi.org/10.1007/978-1-61779-382-0>

Pedersen, B. K., Åkerström, T. C. A., Nielsen, A. R., & Fischer, C. P. (2007). Role of myokines in exercise and metabolism. *Journal of Applied Physiology*, *103*(3), 1093–1098.

<https://doi.org/10.1152/jappphysiol.00080.2007>

Perry, C. G. R., Lally, J., Holloway, G. P., Heigenhauser, G. J. F., Bonen, A., & Spriet, L. L. (2010). Repeated transient mRNA bursts precede increases in transcriptional and mitochondrial proteins during training in human skeletal muscle. *Journal of Physiology*, *588*(23), 4795–4810. <https://doi.org/10.1113/jphysiol.2010.199448>

Petersen, A. M. W., & Pedersen, B. K. (2005). The anti-inflammatory effect of exercise. *Journal of Applied Physiology*, *98*(4), 1154–1162. <https://doi.org/10.1152/jappphysiol.00164.2004>

Polyzos, A. A., & McMurray, C. T. (2017a, January). The chicken or the egg: mitochondrial dysfunction as a cause or consequence of toxicity in Huntington's disease. *Mechanisms of Ageing and Development*. <https://doi.org/10.1016/j.mad.2016.09.003>

Polyzos, A. A., & McMurray, C. T. (2017b, January). The chicken or the egg: mitochondrial dysfunction as a cause or consequence of toxicity in Huntington's disease. *Mechanisms of Ageing and Development*. <https://doi.org/10.1016/j.mad.2016.09.003>

Poudevigne, M. S., & O'Connor, P. J. (2006). A review of physical activity patterns in pregnant women and their relationship to psychological health. *Sports Medicine*, *36*(1), 19–38. <https://doi.org/10.2165/00007256-200636010-00003>

Puigserver, P., & Spiegelman, B. M. (2003, February). Peroxisome proliferator-activated receptor- γ coactivator 1 α (PGC-1 α): Transcriptional coactivator and metabolic regulator.

Endocrine Reviews. <https://doi.org/10.1210/er.2002-0012>

Ramírez-Vélez, R., Bustamante, J., Czerniczyniec, A., Aguilar De Plata, A. C., & Lores-Arnaiz, S. (2013). Effect of exercise training on enos expression, NO production and oxygen metabolism in human placenta. *PLoS ONE*, 8(11).

<https://doi.org/10.1371/journal.pone.0080225>

Reilly, F. D., & Russell, P. T. (1977). Neurohistochemical evidence supporting an absence of adrenergic and cholinergic innervation in the human placenta and umbilical cord. *The Anatomical Record*, 188(3), 277–285. <https://doi.org/10.1002/ar.1091880302>

Rice, M. W., Smith, K. L., Roberts, R. C., Perez-Costas, E., & Melendez-Ferro, M. (2014). Assessment of cytochrome C oxidase dysfunction in the substantia nigra/ventral tegmental area in schizophrenia. *PLoS ONE*, 9(6), e100054.

<https://doi.org/10.1371/journal.pone.0100054>

Roberts, K., Shields, M., de Groh, M., Aziz, A., & Gilbert, J.-A. (2012). Overweight and obesity in children and adolescents: Results from the 2009 to 2011 Canadian Health Measures Survey. Retrieved from <http://www.statcan.gc.ca/pub/82-003-x/2012003/article/11706-eng.htm>

Rooney, B. L., & Schauberger, C. W. (2002). Excess pregnancy weight gain and long-term obesity: One decade later. *Obstetrics and Gynecology*, 100(2), 245–252.

[https://doi.org/10.1016/S0029-7844\(02\)02125-7](https://doi.org/10.1016/S0029-7844(02)02125-7)

Rudra, C. B., Sorensen, T. K., Luthy, D. A., & Williams, M. A. (2008). A prospective analysis of recreational physical activity and preeclampsia risk. *Medicine and Science in Sports and Exercise*, 40(9), 1581–1588. <https://doi.org/10.1249/MSS.0b013e31817cab1>

- Russell, A. P., Foletta, V. C., Snow, R. J., & Wadley, G. D. (2014). Skeletal muscle mitochondria: A major player in exercise, health and disease. *Biochimica et Biophysica Acta - General Subjects*. <https://doi.org/10.1016/j.bbagen.2013.11.016>
- Samjoo, I. A., Safdar, A., Hamadeh, M. J., Glover, A. W., Mocellin, N. J., Santana, J., ... Tarnopolsky, M. A. (2013). Markers of Skeletal Muscle Mitochondrial Function and Lipid Accumulation Are Moderately Associated with the Homeostasis Model Assessment Index of Insulin Resistance in Obese Men. *PLoS ONE*, 8(6), e66322. <https://doi.org/10.1371/journal.pone.0066322>
- Scarpulla, R. C. (2008). Transcriptional Paradigms in Mammalian Mitochondrial Biogenesis and Function. *Physiological Reviews*, 88(2), 611–638. <https://doi.org/10.1152/physrev.00025.2007>
- Schnyder, S., & Handschin, C. (2015). Skeletal muscle as an endocrine organ: PGC-1 α , myokines and exercise. *Bone*. <https://doi.org/10.1016/j.bone.2015.02.008>
- Sitras, V., Paulssen, R. H., Gronaas, H., Vartun, A., & Acharya, G. (2008). Gene expression profile in labouring and non-labouring human placenta near term. *Molecular Human Reproduction*, 14(1), 61–65. <https://doi.org/10.1093/molehr/gam083>
- Smolina, N., Bruton, J., Kostareva, A., & Sejersen, T. (2017). Assaying mitochondrial respiration as an indicator of cellular metabolism and fitness. In *Methods in Molecular Biology* (Vol. 1601, pp. 79–87). https://doi.org/10.1007/978-1-4939-6960-9_7
- Soleymanlou, N., Jurisica, I., Nevo, O., Ietta, F., Zhang, X., Zamudio, S., ... Caniggia, I. (2005). Molecular evidence of placental hypoxia in preeclampsia. *Journal of Clinical Endocrinology and Metabolism*, 90(7), 4299–4308. <https://doi.org/10.1210/jc.2005-0078>

- Stewart, F. M., Freeman, D. J., Ramsay, J. E., Greer, I. A., Caslake, M., & Ferrell, W. R. (2007). Longitudinal assessment of maternal endothelial function and markers of inflammation and placental function throughout pregnancy in lean and obese mothers. *Journal of Clinical Endocrinology and Metabolism*, 92(3), 969–975. <https://doi.org/10.1210/jc.2006-2083>
- Strachan, D. P., & Hart, J. T. (1990). Fetal and placental size and risk of hypertension in adult life. *BMJ*, 301(6751), 552–552. <https://doi.org/10.1136/bmj.301.6751.552>
- Terjung, R. L., Zarzeczny, R., & Yang, H. T. (2002, September 1). Muscle blood flow and mitochondrial function: influence of aging. *International Journal of Sports Nutrition and Exercise Metabolism*. <https://doi.org/10.1123/ijsnem.12.3.368>
- Tremblay, M. S., Warburton, D. E. R., Janssen, I., Paterson, D. H., Latimer, A. E., Rhodes, R. E., ... Duggan, M. (2011). New Canadian Physical Activity Guidelines. *Applied Physiology, Nutrition, and Metabolism*, 36(1), 36–46. <https://doi.org/10.1139/H11-009>
- Wang Y, Z. S. (2010). Cell types of the placenta. In *Biology of the placenta*. San Rafael (CA): Morgan & Claypool Life Sciences. Retrieved from <https://www.ncbi.nlm.nih.gov/books/NBK53245/>
- Warburton, D. E. R., Gledhill, N., & Quinney, A. (2001). The Effects of Changes in Musculoskeletal Fitness on Health. *Canadian Journal of Applied Physiology*, 26(2), 161–216. <https://doi.org/10.1139/h01-012>
- Warburton, D. E. R., Nicol, C. W., & Bredin, S. S. D. (2006). Health benefits of physical activity: the evidence. *CMAJ: Canadian Medical Association Journal = Journal de l'Association Medicale Canadienne*, 174(6), 801–9. <https://doi.org/10.1503/cmaj.051351>

- Wei, J.-N., Sung, F.-C., Li, C.-Y., Chang, C.-H., Lin, R.-S., Lin, C.-C., ... Chuang, L.-M. (2003). Low Birth Weight and High Birth Weight Infants Are Both at an Increased Risk to Have Type 2 Diabetes Among Schoolchildren in Taiwan. *Diabetes Care*, 26(2), 343–348. <https://doi.org/10.2337/diacare.26.2.343>
- Weissgerber, T. L., Davies, G. A. L., & Roberts, J. M. (2010). Modification of angiogenic factors by regular and acute exercise during pregnancy. *Journal of Applied Physiology*, 108(5), 1217–1223. <https://doi.org/10.1152/jappphysiol.00008.2010>
- Westermann, B. (2010, December). Mitochondrial fusion and fission in cell life and death. *Nature Reviews Molecular Cell Biology*. <https://doi.org/10.1038/nrm3013>
- WHO. (2005). *Preventing Chronic Diseases: A Vital Investment*. World Health Organization Global Report. WHO Press. Retrieved from [https://books.google.ca/books?hl=en&lr=&id=dF00DgAAQBAJ&oi=fnd&pg=PR3&dq=prevalence+of+chronic+disease+in+canada&ots=8WVvFtznMw&sig=yR85w0SGqTBeKxNwozO2hzEjt0s#v=onepage&q=prevalence of chronic disease in canada&f=false](https://books.google.ca/books?hl=en&lr=&id=dF00DgAAQBAJ&oi=fnd&pg=PR3&dq=prevalence+of+chronic+disease+in+canada&ots=8WVvFtznMw&sig=yR85w0SGqTBeKxNwozO2hzEjt0s#v=onepage&q=prevalence+of+chronic+disease+in+canada&f=false)
- WHO european ministerial conference on counteracting obesity. (2007). *WHO Conference report*. Copenhagen, Denmark. Copenhagen, Denmark.
- Wilkin, T. J., Metcalf, B. S., Murphy, M. J., Kirkby, J., Jeffery, A. N., & Voss, L. D. (2002). The Relative Contributions of Birth Weight, Weight Change, and Current Weight to Insulin Resistance in Contemporary 5-Year-Olds. *Diabetes*, 51(12), 3468–3472. <https://doi.org/10.2337/diabetes.51.12.3468>
- Wolf, H. T., Owe, K. M., Juhl, M., & Hegaard, H. K. (2014). Leisure time physical activity and the risk of pre-eclampsia: A systematic review. *Maternal and Child Health Journal*, 18(4),

899–910. <https://doi.org/10.1007/s10995-013-1316-8>

Wooley, S. C., & Garner, D. M. (1991). Obesity treatment: the high cost of false hope. *Journal of the American Dietetic Association*, *91*(10), 1248–51. Retrieved from <http://www.ncbi.nlm.nih.gov/pubmed/1918744>

World Medical Association declaration of Helsinki: Ethical principles for medical research involving human subjects. (2013, November 27). *JAMA - Journal of the American Medical Association*. American Medical Association. <https://doi.org/10.1001/jama.2013.281053>

Yan, Z., Lira, V. A., & Greene, N. P. (2012, July). Exercise training-induced regulation of mitochondrial quality. *Exercise and Sport Sciences Reviews*. <https://doi.org/10.1097/JES.0b013e3182575599>

Yang, J. S., Kim, J., Park, S., Jeon, J., Shin, Y. E., & Kim, S. (2013). Spatial and functional organization of mitochondrial protein network. *Scientific Reports*, *3*. <https://doi.org/10.1038/srep01403>

Appendix A: Western Blot Protocol

Protein Extraction:

- 1- Place mortar and pestle into dry ice and pour some liquid nitrogen into the mortar.
- 2- Put lid on box and allow tools to cool for 5 minutes.
- 3- Place sample into mortar and grind with pestle until the sample is a fine powder.
-If sample starts thawing, pour more liquid nitrogen into mortar and wait a few minutes.
- 4- Scoop powder into a new tube.
- 5- Weigh out ~50-100mg of tissue into a 2ml tube, keeping the sample frozen.
- 6- Add 1ml of cold RIPA buffer and homogenize samples with a mechanical homogenizer for 10 seconds. Return sample to ice for 10 seconds then homogenize again for 10 seconds
- 7- Return sample to ice until all of the samples are homogenized.
- 8- Centrifuge all samples at max speed for 10 minutes at 4°C.
- 9- Spin down samples and collect supernatant → this is your protein sample.

Sample Preparation:

- 10- Quantify protein samples using Biorad DC assay.
- 11- Aim to prepare 100ul of a 1ug/uL solution, enough for 4 gels. (use 25ul of 4x reducing protein loading buffer, sample, and make up remaining volume with RIPA buffer)
- 12- Samples can be used immediately or stored at -80°C for future use.

Running Gel:

- 1- Precast gel is used, so no gel preparation required.
- 2- Once gel is solid, assemble electrophoresis unit and fill inner and outer chambers to appropriate level with 1X Running buffer. (I prefer to fill between 2-4 gel lines for 1 or 2 gels)
- 3- Load **5ul** of ladder and **15ul** of each sample. Any blank well should be filled with 4x loading buffer diluted to 1x with lysis buffer.
- 4- Run gel at 200V until the loading dye front reaches the bottom of the gel.

Transfer and Stain-Free visualization:

- 1- While gel is running, cut appropriate sized PVDF membrane. Soak it in 100% **Ethanol** for 20 **minutes**, then transfer and leave it in cold transfer buffer for at least 10 minutes.
- 2- Once gel is finished running, crack apart glass and immediately expose gel to UV light for 45 seconds. (Protein gel → Stain-free → Optimal exposure)
- 3- Remove gel and leave in cold transfer buffer for at least 10 minutes.
- 4- Create the transfer “sandwich” and run at 100v for 1 hour.
- 5- Disassemble cassette and place membrane in TBS-T.

- 6- Expose membrane to UV light (Protein Blot → Stain Free → Dark bands → optimal exposure).
- 7- Return membrane to TBS-T. This will be used to normalize the results later using ImageLab.

Traditional Probing Method:

- 1- Pour 5% powdered milk onto the membrane to block, rock for 1 hour.
- 2- Pour primary antibody made in 5% powdered milk onto membrane.
- 3- Incubate on a rocker for one hour at room temperature.
- 4- Wash membrane 3x5 minutes with TBS-T.
- 5- Dilute Goat Anti-Mouse secondary antibody 1/5000 in 5% powdered milk and pour onto membrane. Incubate on rocker for 1 hour.
- 6- Wash membrane 3x10 minutes with TBS-T.
- 7- Mix ECL kit and pipette onto membrane for 3 minutes.
- 8- Visualize membrane.

Appendix B: High-Resolution Respirometry Protocol

A) Collection

B) Preparation

C) Isolation Protocol

D) BCA Protein Quantification Protocol

E) OPS Preparation and Calibration Protocol

F) Substrate/Inhibitor Protocol

Appendix

1) Cleaning and Troubleshooting

2) Tools and Apparatus

3) Reagents

A) Collection

1. Before heading to the hospital/birthing centre, make sure you take:

- 1 small ice box filled with ice
- 1 50 ml falcon tube filled with 50 ml of “Buffer A”
- 3 50 mL falcon tubes, empty

2. When collecting tissue samples, cut out two large pieces of tissue from cotyledons close to the centre of the placenta. Place them on the absorbent cloth and squish them to release as much blood as possible. Using forceps, dip them in PBS a few times to release more blood. Take the tissue and place it in one of the falcon tubes with 50 ml Buffer A. Label this tube “Central”.

3. Repeat step 2 using peripheral tissue.

4. Keep these tubes on ice until you get to the lab at RGN.

B) Preparation

1. Record the time of arrival at RGN.
2. Turn on the centrifuge in preparation for the isolation protocol. If the centrifuge door is open, close it. Set the temperature to 4°C.
3. Turn on the water bath located below the Oxygraph chambers. The temperature should be set to 23°C. Make sure the water is flowing through the tubes connecting the Oxygraph chambers; if not, check around for kinks.
4. Take your central and peripheral tubes to the scale. Tare a weigh boat, then fish out the tissue using a spatula and place on the weigh boat. Quickly record the weight and return the tissue to the buffer, then repeat for the other tube of tissue.
5. Create 200 mL **Buffer A**: Tris HCl 20 mL, Tris EGTA 20 mL (both in the lab fridge 1), 19.46g Sucrose (glass cabinet), fill with clean water to 200 mL.

C) Isolation Protocol

You will need:

- 2 small homogenizing tubes, with plastic pestles removed (keep on ice), label C and P
- 2 Eppendorf tubes labeled “Central Homogenate” and “Peripheral Homogenate”
- 6 Nalgene clear plastic tubes (50 mL) (keep on ice), label C1, C2, C3, P1, P2, P3
- 2 caps for the Nalgene tubes
- 1 large beaker for liquid waste
- 2 plastic syringes
- 2 metal syringe needles
- Pipettes & tips, 5000 uL and 200 uL

1. Remove the tissue from one of the tubes using a spatula and place into a homogenizing tube. Pour about 10-15 mL of buffer A from the original falcon tube into the homogenizing tube.
2. Homogenize tissue using the handheld metal homogenizer on setting 6. Turn on for 2 seconds, moving the homogenizer up and down in the tube, then turn off and remove the homogenizer and wait for 10 seconds. Repeat 4 times until tissue is fully homogenized. **Keep sample in a beaker**

of ice water at all times during this step, as the homogenizer produces heat. Discard old buffer A falcon tube.

3. *Collect about 100 uL of the tissue homogenate, transfer this to an Eppendorf tube, then freeze the tube in liquid nitrogen. Transfer the rest of the homogenate to a clear Nalgene tube and fill to about 1-2 cm below the cap with buffer A from the newly-made batch.

4. Repeat steps 1-3 using the other tissue (central or peripheral).

5. **Centrifuge #1** Transfer to Nalgene tube 1, fill to 1cm below the top with buffer A. Centrifuge at 1000g for 10 minutes at 4°C. **Record the time that Centrifuge 1 was started.**

(**Person 1:** begin preparing Oxygraph electrodes, shown in E).

(**Person 2:** if cord blood was collected, person 2 will still be working on this).

6. **Centrifuge #2** Transfer supernatant to a clean tube 2 using the syringe and a needle, centrifuge again at 1000g for 10 minutes at 4°C.

(**Person 1:** begin calibration, shown in E).

(**Person 2:** Prepare 100 mL Buffer B in 250 mL graduated cylinder: Tris HCl 10 mL, Tris EGTA 0.5 mL, 9.78g Sucrose, fill with water to 100 mL, pour into beaker at 4°C).

7. **Centrifuge #3** Collect supernatant, transfer to a clean tube 3 by pouring slowly, be careful not to disturb pellet. Centrifuge at 10000g (should read 9190 rpm) for 10 minutes at 4°C.

(**Person 1 or 2:** get Oxygraph buffer and TMPD from -80° freezer, let buffer thaw in water bath (suspend from cap). Transfer remaining Buffer A into an empty falcon tube).

(**Person 1:** continue calibration)

(**Person 2:** begin preparing BSA standards, located in D)

8. **Centrifuge #4** Discard supernatant with the vacuum, re-suspend in the same tube with buffer B with regular pipette (2mL to break up pellet, then fill). Centrifuge again at 10000g for 10 minutes at 4°C.

(**Person 1:** Make 500 mM pyruvate solution: 5.5 mg pyruvate powder (freezer), 100 uL H₂O. This can be done before or after the incubation in D.)

(**Person 2:** continue preparing BSA standards, be ready for plating quickly)

9. Discard supernatant with vacuum, re-suspend in 200 uL buffer B. Proceed to protein quantification.

D) BCA Protein Quantification Protocol

You will need:

- 96-well plate
- ~10 plastic micro centrifuge tubes
- BCA Protein Quantification Kit
- 10 mL beaker (for BCA/Copper mix)
- Isolated mitochondria

1. Create 5 BSA standards using the BCA Protein Quantification kit using micro centrifuge tubes:

- a) **0**: 0 uL BSA, 240 uL water
- b) **0.125**: 30 uL BSA, 210 uL water
- c) **0.25**: 60 uL BSA, 180 uL water
- d) **0.375**: 90 uL BSA, 150 uL water
- e) **0.5**: 120 uL BSA, 120 uL water

2. Create a 1:50 mitochondria solution (2 uL mitochondria, 98 uL water).

3. Put triplicate of 25 uL of each solution in wells.

-Using the left side of the well-plate (or the right side if the left has been used), put the standards in the first five rows A-E, putting each standard in wells 1, 2, and 3. In rows F and G, put a triplicate of the Central dilution (F), and Peripheral dilution (G). Put 200 uL water in triplicate in row H.

4. Prepare BCA mix: 5.88 mL BCA, 120 uL Copper solution.

5. Pipette 200 uL of the BCA mix into each well using the repeater pipette (not row H).

6. Incubate at 37°C for 15 mins.

7. Take your plate to the plate reader PC on the other side of the lab. Open up the Omega software. Select “measure”, then select the BCA-PLACENTA protocol. ***Make sure you select “Edit” on the protocol to match the software’s template with your plate.** Confirm to start the reading.

8. Enter the absorbance values into the excel spreadsheet template to calculate the concentration of the mitochondrial samples.

E) Oxygraph Preparation and Calibration Protocol

Never touch the gold part of the electrode with water. EVER!

You will need:

- 4 electrodes
- Rolling paper
- Membrane tape
- KCl solution
- Thin-tip forceps
- 4 large rubber rings and 4 small rubber rings
- Ring setting tool
- DD water and 70% ethanol spray bottles
- Sodium hydrosulfite
- Magnetic stir bar

1. Turn on water bath.
2. Cut rolling paper into squares (cutting off the glue strip), and cut membrane into similar-sized squares.
3. Drop KCL solution onto the circular electrode, adding a drop onto the centre.
4. Place the paper onto the centre with forceps. Place the membrane onto the paper.
5. Place the smaller ring around the centre, setting it with the ring tool. Place the larger ring onto the circular electrode.
6. Open the bottom of the chamber and place the electrode inside, close it. Plug the electrode in.

*If the area where the electrode sits is covered in a white salty residue, rinse off the chambers with water and dry with a Kimwipe before inserting the electrode.

7. Place the stirring magnet inside the chamber, and add 1 mL of water.

Calibration (you can calibrate a chamber on both computers at the same time)

8. Open the O2view software and click the “Liquid Calibration” button. Select Channel 1, set the temperature to 23C, and keep the pressure as is. Turn the stirrer on (light blue button) and set the speed to 20. Press “Calibrate”.

9. Follow the steps. When the program says “establish 0”, add sodium hydrosulfite*.
10. Save the calibration.
11. When the calibration is done, vacuum out the calibration solution and wash. Make sure you put water in the chamber afterwards so the membrane does not dry out.
12. Repeat calibration with Channel 2.
13. **Repeat whole procedure for all four chambers.**
14. Follow the steps in the reagent protocol.

F) Substrate/Inhibitor Protocol

You will need:

- Two drawers of Hamilton syringes
- Pipettes & tips, 2.5 uL, 10 uL, 100 uL, 1000 uL
- Bag of substrates found in -20°C freezer labeled “Jon’s substrates & inhibitors”
- If any substrates need to be replaced, the replacements are found in a large plastic bag in the same freezer

At each step, place two labeled markers on the software, for chamber 1 and chamber 2.

1. Add Respiration buffer (from -80° freezer), add 9 uL Pi, 5 uL MgCl₂, 1 uL BSA
(Volume of respiration buffer = 1 mL – mitochondrial suspension volume)
2. Measure baseline until all chambers stop fluctuating (5-10 mins).
3. Add mitochondria (0.5 mg), Measure mitochondria baseline slope. **Make sure you add Central mitochondria to Chamber 1, and Peripheral mitochondria to Chamber 2.**
4. Add **Glutamate (10 uL), Malate (5 uL), and Pyruvate (10 uL)**, measure protein complex 1 activity.
5. Add **Succinate (20 uL)**, measure complex 2 activity.
6. Add **Cytochrome C (2.5 uL)**, test membrane integrity.
7. Add **ADP (40 uL)**, measure state III phosphorylation slope. This slope often takes a while to stabilize (~10 minutes). If oxygen level approaches 0, take off the cap and pipette air/bubbles into the chamber until the oxygen level comes back up.
8. Add **Amytal (3.3 uL)**, measure halt of complex 1 activity (may not have much of an effect).
9. Add **CCCP (try 10 uL)**, measure reduced OXPHOS due to uncoupling.
10. Add **Antimycin A (20 uL)**, inhibit complex 3 activity (halts ETC).
11. Add **Ascorbate (3 uL) and TMPD (3 uL)**, measure complex 4 activity.
12. Add **KCN (30 uL)**, measure halt of complex 4 activity.

End

Once the protocol is finished, stop recording and save the data as “PLAXXX DD-MMM-YY P/C” (D=day, M=month, Y=year, P=peripheral, C=central). Calculate the slopes of each step using the software, and export the data onto an Excel sheet with the same name.

Appendix C: Calculated statistical power and estimated required sample size for the statistically-significant findings of the study.

Result	Sample size	Effect size	P-value	Statistical power	Estimated required sample size
Aim 1: Effect of MVPA on placenta mitochondrial function and content					
Complex II protein correlation - Peripheral	12	0.683	0.014	0.831*	12
Total protein correlation - Peripheral	12	0.599	0.040	0.647	17
State 3 respiration higher in Active group - Central	17	1.520	0.015	0.761	20
Aim 2: Regional differences in placenta mitochondrial function and content					
Complex I protein – Central higher than Peripheral	12	2.004	<0.001	0.999*	5
Complex II protein – Central higher than Peripheral	12	0.925	0.008	0.830*	12
Total protein – Central higher than Peripheral	12	0.665	0.042	0.555	20
Aim 3: Offspring sex differences in placenta mitochondrial function and content					
MVPA and Complex V protein correlation - Peripheral female	7	0.783	0.037	0.758	8
Complex I protein higher in females - Peripheral	12	1.405	0.031	0.582	20

Statistical power and estimated required sample size were calculated using G*Power software. Effect size is displayed as r for correlations, and Cohen's d_z for t-tests. α -error was set to 0.05, and $1 - \beta$ error probability was set to 0.80. * indicates statistical power > 0.8.