

# **SAP Based Rapid Dewatering of Oil Sands Mature Fine Tailings**

By  
**Aida Farkish**

A thesis submitted  
under the supervision of Dr. Mamadou Fall

In partial fulfillment of the  
requirements for the degree of  
Master of Applied Science  
in Environmental Engineering  
Department of Civil Engineering  
University of Ottawa  
Ottawa, Canada  
April, 2013

The M.A.Sc. in Environmental Engineering is a joint program  
with Carleton University administrated by  
Ottawa-Carleton Institute for Environmental Engineering  
© Aida Farkish, Ottawa, Canada, 2013

*To My Parents*

## Abstract

Mature fine tailings (MFT), as a mixture of residual bitumen, sand, silt, fine clay particles and water, are a byproduct of oil sands extraction. The large volume, and poor consolidation and water release ability of MFT have been causing significant economic and environmental concerns. Therefore, several studies have been implemented on finding innovative dewatering/disposal techniques. As a result, different methods have been introduced and tested at a laboratory or a field scale, yet very few of these are commercially used in the oil sands industries. Despite the extensive research, an optimal solution has not been found due to the lack of technical or economic feasibility.

In the present study, a novel approach that consists of the rapid dewatering of MFT by using a super absorbent polymer (SAP) to produce dense MFT is proposed. A comprehensive laboratory investigation on the geotechnical characteristics and behavior before and after treatment of MFT is conducted. The effects of SAP based dewatering and freeze/thaw cycles on the undrained shear strength of dewatered MFT by using a vane shear apparatus are studied. Furthermore, the ability of recycled SAP to dewater and densify MFT is assessed. Finally, this study provides the results of consolidation and hydraulic conductivity testing to evaluate the void ratio versus effective stress and hydraulic conductivity of MFT. The effects on the behavior and characteristics of MFT after amendment with usage of recycled SAP are also investigated.

The results indicate that SAP has the ability to significantly dewater, densify and increase the undrained shear strength of MFT. Furthermore, when subjected to freeze/thaw cycles, the MFT dewatered with SAP shows an additional increase in strength and solid content. It is also found to be possible to regenerate the polymer (still within sachets) through light thermal drying, and the regenerated SAP can still significantly dewater and thus increase the shear strength and solid content of the MFT. In addition, the obtained high solid content affects and improves the compressibility of the material, thus resulting in low initial void ratios. On the other hand, low hydraulic permeability that is derived from low initial void ratios and consolidation is improved by the freeze/thaw process due to the interconnected voids created during the freezing process.

## **Acknowledgement**

I would like to express my deepest gratitude to my supervisor and mentor, Dr. Mamadou Fall, for his constant guidance, support, motivation and unceasing help during the course of my Master's degree.

Special thanks to Mr. Jean Claude Celestin for his continual help, useful information and technical assistance. I would also like to acknowledge Dr. Jules-Ange Infante for his technical assistance and support.

I am thankful to my many student colleagues for providing a stimulating and fun environment in which to learn and grow.

I am indebted to my beloved uncles, Jamil and Zahed Mardukhi, for their fatherly support and generous care whenever I was in need during my stay in Canada.

Finally, I would like to take this opportunity to express my profound gratitude from the deepest part of my heart to my beloved parents, Fayzeh Mardukhi and Kourosch Farkish, and my dear brother, Araz Farkish. I cannot imagine my current position without their love and support. To them, I dedicate this thesis.

# Table of Contents

Abstract .....	i
Acknowledgement .....	ii
List of Figures .....	vii
List of Tables .....	ix
<b>Chapter One - Introduction .....</b>	<b>1</b>
1.1 General statement.....	1
1.2 Objective of the research .....	2
1.3 Scope of thesis .....	3
1.4 Organization of manuscript.....	3
1.5 References.....	5
<b>Chapter Two - Theoretical and Technical Background.....</b>	<b>6</b>
2.1 Introduction.....	6
2.1.1 Canadian oil sands .....	6
2.1.2 Oil sands bitumen .....	8
2.2 Review of oil sands extraction technology.....	8
2.2.1 Introduction.....	8
2.2.2 Mining.....	8
2.2.3 Open pit mining .....	8
2.2.4 Hot water process.....	9
2.2.5 In situ recovery .....	10
2.3 Mature fine tailings .....	12

2.4 MFT properties .....	13
2.4.1 MFT mineralogy .....	13
2.4.2 Composition of MFT pore water .....	13
2.5 Tailings ponds.....	14
2.6 Environmental issues of MFT.....	15
2.6.1 Impacts of tailings ponds on land use .....	15
2.6.2 Impacts of tailings ponds on regional water supply.....	15
2.6.3 Impacts of tailings ponds on regional and ground water quality .....	15
2.6.4 Impacts of tailings ponds on air quality .....	16
2.7 Oil sands tailings management .....	16
2.8 Tailings treatment technologies .....	17
2.8.1 Chemical or biological amendments.....	18
2.8.2 Physical or mechanical processes .....	23
2.8.3 Natural processes .....	26
2.8.4 Mixtures/co-disposal.....	28
2.8.5 Permanent storage .....	29
2.9 Super absorbent polymer .....	31
2.9.1 Absorption capacity .....	31
2.9.2 Types of SAPs.....	34
2.9.3 SAP properties .....	35
2.10 Summary and conclusions .....	36
2.11 References.....	38

<b>Chapter Three - Technical paper I – SAP based rapid dewatering of oil sands mature fine tailings .....</b>	<b>42</b>
---	-----------

3.1 Introduction.....	43
3.2. Experimental program .....	46
3.2.1. Material.....	46
3.2.2 SAP dewatering methods, specimen preparation and mix proportioning .....	49
3.3 Testing and procedures .....	51
3.3.1 Freeze–thaw cycles .....	51
3.3.2 Regeneration of SAP.....	53
3.3.3. Vane shear tests.....	54
3.3 Results and discussion .....	56
3.3.1 Vane shear testing on SAP-MFT (Direct method) .....	56
3.3.2 Shear strength of MFT dewatered with SAP-sachets (indirect method) .....	59
3.3.3 Effect of freeze/thaw.....	62
3.4 Conclusion .....	67
3.5 References.....	69

**Chapter Four - Technical paper II - Consolidation and hydraulic conductivity of oil sands mature fine tailings dewatered by super absorbent polymer .....** 72

4.1 Introduction.....	72
4.2 Experimental programme.....	74
4.2.1 Materials .....	74
4.2.2 SAP dewatering process .....	77
4.2.3 Freeze/thaw dewatering .....	78
4.2.4 SAP regeneration process .....	79
4.2.5 Specimen preparation.....	80

4.2.6 Testing of the specimens.....	81
4.3. Results and discussion .....	83
4.3.1 Consolidation behaviour of MFT treated by SAP .....	83
4.3.2 Hydraulic conductivity of MFT treated by SAP .....	88
4.4 Summary and conclusion.....	91
4.5 Acknowledgment .....	92
4.6 Reference .....	93
<b>Chapter Five - Summary, conclusion &amp; recommendations.....</b>	<b>96</b>
5.1 Summary.....	96
5.2 Conclusion .....	97
5.2 Recommendations.....	98
<b>Appendix A .....</b>	<b>99</b>
<b>Appendix B .....</b>	<b>107</b>

## List of Figures

Fig. 1.1 Schematic diagram that illustrates the organization of the thesis.....	4
Fig. 2.1 Oil sands areas .....	6
Fig. 2.2 Structural model of Athabasca oil sands .....	7
Fig. 2.3 A typical commercial HWP plant.....	10
Fig. 2.4 MFT tailings pond. ....	14
Fig. 2.5 Particle-size distribution curves for various samples of thickened tailings.....	19
Fig. 2.6 pH and viscosity of desanded thickener feed (Chalaturnyk et al., 2002). ....	22
Fig. 2.7 Sedimentation rate of desanded thickener feed tailings (Chalaturnyk et al., 2002). ....	22
Fig. 2.8 Filtration curves of MFT diluted to 5 wt% and 10 wt% (Alamgir et al., 2012).....	25
Fig. 2.9 Freeze–thaw dewatering mechanism (Dawson et al., 1999) .....	27
Fig. 2.10 Water cap tailings test ponds .....	30
Fig. 2.11 Super absorbent polymer (SAP) .....	31
Fig. 2.12 A schematic drawing of a swelling SAP (Zohuriaan-Mehr and Kabiri, 2008). ....	32
Fig. 3.1 MFT grain size distribution .....	47
Fig. 3.2 Absorption capacity of the SAP .....	49
Fig. 3.3a Front view of the slope table. Fig. 3.3.b drainage system .....	52
Fig. 3.4 Change in the absorption capacity of the SAP by performing different methods of regeneration.....	54
Fig. 3.5a Vane shear strength of MFT directly mixed with SAP versus time, Fig.3.5b Solid content of MFT directly mixed with SAP vs. time.....	57
Fig. 3.6 Effect of changes made with direct method on the MFT with the addition of different amounts of SAP: a) 0%; b)1%; c) 3% .....	58

Fig. 3.7a Shear strength of MFT treated with SAP sachet versus curing time, Fig. 3.7b MFT shear strength versus solids content, Fig. 3.7c Solids content of MFT treated with SAP sachets versus curing time .....	60
Fig. 3.8 Solids content of MFT directly mixed with SAP (D) and MFT mixed with SAP sachets (S) versus curing time .....	62
Fig. 3.9.a Effect of freeze/thaw on 1 day cured samples, Fig. 3.9.b Effect of freeze/thaw on 3 day cured samples, Fig. 3.9.c Effect of freeze/thaw on 7day cured samples .....	64
Fig. 3.10 Effect of freeze/thaw on undrained shear strength of MFT with SAP sachets.....	65
Fig. 3.11 Effect of freeze/thaw on solids content of MFT with SAP sachets.....	65
Fig. 3.12 Effect of SAP regeneration on shear strength of MFT .....	67
Fig. 3.13 Effect of SAP regeneration on solids content of MFT .....	67
Fig. 4.1 X-ray diffractogram for the MFT. ....	75
Fig. 4.2 Grain size distribution of the mature fine tailings used.....	76
Fig. 4.3 Absorption capacity of the SAP .....	77
Fig. 4.4 Change in the absorption capacity of the SAP as a result of regeneration cycles.....	80
Fig. 4.5 Apparatus used for consolidation and hydraulic conductivity tests .....	81
Fig. 4.6 Consolidation test results for MFT treated by SAP sachets .....	84
Fig. 4.7 Consolidation test results for MFT treated by recycled SAP .....	85
Fig. 4.8 Consolidation test results for MFT dewatered by SAPs and freeze/thaw .....	87
Fig. 4.9 Hydraulic conductivity test results for MFT dewatered by SAP sachets .....	88
Fig. 4.10 Hydraulic conductivity test results for MFT dewatered by recycled SAPs .....	89
Fig. 4.11 Hydraulic conductivity test results for MFT dewatered by SAPs and freeze/thaw.....	91

## List of Tables

Table 2.1 In-place volumes and established reserves of oil sands at the end of 2012.....	7
Table 2.2 Important factors that affect SAP workability (Zohuriaan-Mehr and Kabiri, 2008)....	33
Table 3.1 MFT mineralogy.....	47
Table 3. 2 Pore water chemistry of the MFT used.....	47
Table 3.3 Effects of different physical and environmental factors on the behaviour of SAP (adapted from Zohuriaan-Mehr et al. 2008) .....	49
Table 4. 1 Pore water chemistry of the MFT used.....	76
Table 4.2 Properties of consolidation test specimens .....	84
Table 4.3 Properties of consolidation test specimens .....	85
Table 4.4 Properties of consolidation test specimens .....	86

# Chapter 1

## Introduction

### 1.1 General statement

Oil sands are an extra heavy form of petroleum and do not flow to wells in their natural state due to high viscosity. Canadian oil sands deposits located in northern Alberta are one of the world's most vast hydrocarbon deposits that occupy an area of about 142,000 square kilometers (km<sup>2</sup>) (NEB, 2004). Oil sands deposits are mined and processed to remove sand, water, mineral particles and other extra material added during extraction.

Mining operations result in slurry tailings with high water content that are pumped into large surface ponds. The majority of the sand and coarse silt particles aggregate shortly after deposition and are removed from the rest of the slurry. After 2 to 3 years, the tailings consolidate at the bottom of the tailings ponds into 30 percent solid content with no further consolidation, thus creating a strong suspension called mature fine tailings (MFT). MFT are a mixture of residual bitumen, sand, silt, fine clay particles and water; the clay content varies from approximately 8% to 25%, and the solid content generally ranges from 35% to 65%. Due to the poor water release ability, poor consolidation, low permeability and low strength of the MFT, tailings dewatering under natural conditions is not feasible (Mikula et al., 1996). Several types of materials added to the tailings during the mining and upgrading processing of oil sands affect the chemical and physical properties of MFT particles (OSRIN Report, 2010). As a result, a strong unique suspension is produced, which governs high water holding capacity.

The oil sands extraction process produces significantly large amounts of slurry tailings that are accumulated in large tailings ponds, thus resulting in the continual necessity to enlarge the contaminant ponds to contain the rapidly produced MFT. Currently, more than 170 km<sup>2</sup> of Alberta's lands are devoted to tailings ponds (Government of Alberta, June 2012) which causes several critical environmental concerns, such as their effects on public health, land use, water supply and air quality. Consequently, various regulations and requirements have been established

for the tailings operations associated with mineable oil sands in order to preserve the environment (ERCB, 2009)

The main objective in oil sands tailings management is to dewater and consolidate the produced MFT to create a trafficable load bearing surface and reduce the dedicated disposal areas (DDAS). In order to determine the optimum technique for dewatering MFT, an understanding of the consolidation rates and permeability behavior of MFT before and after treatment is required. Moreover, treatment time and expenses are two important factors to take into consideration as part of the evaluation of the dewatering techniques.

## **1.2 Objective of the research**

The purpose of the present study is to determine a novel method for dewatering and thickening oil sands MFT by using a super absorbent polymer (SAP). Due to the high price of SAP, the research is directed toward improving the efficiency of SAP by finding a sufficient mixing method and recycling used polymer.

Consequently, the first objective would be to develop an optimized method to mix the MFT and SAP together, thus providing maximum contact between the tailings and polymer. Moreover, in designing the mixing method, the possibility of SAP separation from the MFT should be considered to allow SAP regeneration.

Under this purpose then, finding an applicable method for SAP regeneration is ultimately the next step. The reusing of SAPs reduces the cost of treatment, prevents the waste of useful material and more importantly, preserves the environment. A proper regeneration method should be designed based on the type of SAP that is used to significantly maintain the desorption and absorption abilities of these materials.

As an additional objective, another dewatering technique will be combined to reduce the cost and improve the results. In considering the weather conditions in northern Alberta, the freeze/thaw process is found to be the best fit for the disposal package.

The foremost objective of this study is to obtain various geotechnical parameters of the MFT that indicate their strength (shear strength versus curing time), rate and magnitude of compressibility (void ratio versus effective stress) and hydraulic conductivity (hydraulic

conductivity versus void ratio). The effects of the dewatering methods both by themselves and in combination with other methods will be studied to determine the changes that take place in the properties of the MFT.

### **1.3 Scope of thesis**

In order to achieve the objectives of this thesis, the geotechnical characteristics of the material in question are determined and monitored throughout the treatment. SAP dewatering is managed by using four weight percentages of SAP, including: 0%, 0.5%, 1% and 3%. Also, two different mixing methods are applied to investigate the effect of surface contact on the dewatering ability of used polymers. Moreover, the effect of freeze/thaw cycles on MFT that have been dewatered by SAP is determined by following the method introduced by Johnson et al. (1993).

The examination of the undrained vane shear strength of cured MFT is conducted by using a vane shear apparatus. Laboratory tests that determine the consolidation parameters are performed and variations in the void ratio with effective stress are studied. As well, the equipment allows the determining of changes in the hydraulic conductivity at each step of incremental loading. Tests are carried out in the geotechnical laboratory at the University of Ottawa by following the prescribed standard recommendations (2004 Revision of the ASTM).

### **1.4 Organization of manuscript**

The thesis is organized in the form of technical papers, and divided into five chapters. Chapter One contains the introduction, while Chapter Two provides the literature review. Eight sections are included in Chapter Two; Section One discusses the oil sands resources; Section Two introduces the different oil sands extraction technologies; Sections Three and Four provide an introduction about MFT and their characteristics; Section Five discusses the tailings ponds and evolution of disposed material during storing; Section Six provides an overview about the environmental issues of MFT and tailings ponds; Section Seven presents different oil sands tailings management technologies; and finally, Section Eight gives the background information on SAPs and their potential to be used in waste management.

Chapter Three is the first technical paper. In this paper, SAP based rapid dewatering of oil sands MFT is studied.

Chapter Four is the second technical paper, which deals with the consolidation and hydraulic conductivity of oil sands MFT that have been dewatered by SAP.

Chapter Five contains a summary of the observations and conclusions that have been developed throughout this thesis.

It should be mentioned that because the main results of the thesis are presented as technical papers, some information will be repeated. This is because each paper is independently written (i.e. without taking into account the contents of the other papers or the rest of the document) and in accordance with the manuscript preparation requirements of the corresponding publication medium.

Below is a flow chart that shows the organization of the thesis.

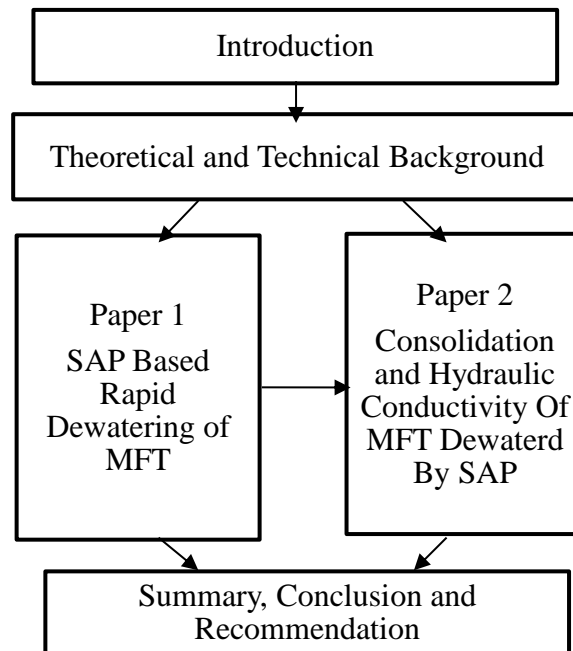

**Fig.1.1** Schematic diagram that illustrates the organization of the thesis.

## 1.5 References

- Energy Resources Conservation Board (ERCB), Directive 074. (2009). "Tailings Performance Criteria and Requirements for Oil Sands Mining Schemes." Alberta Energy Resources Conservation Board, Calgary, Alberta, Canada.
- Government of Alberta. "Tailings" *Government of Alberta*. June 2012. Government of Alberta. (visited 14/2/2013), <http://www.oilsands.alberta.ca/tailings.html>.
- Mikula R.J., Kasperski K.L, Burns R.D, and MacKinnon M D. (1996). "Nature and fate of oil sands fine tailings" *American Chemical Society*, 251 (14), 677-723.
- NEB. (2004). "Canada's oil sands: Opportunities and challenges to 2015: an update." National Energy Board, Alberta, Canada.
- OSRIN Report. (2010). "Oil Sands Tailings Technology Review." BGC Engineering Inc., Oil sands research and information network, University of Alberta, School of Energy and the Environment, Edmonton, Alberta, Canada.

# Chapter 2

## Theoretical and Technical Background

### 2.1 Introduction

#### 2.1.1 Canadian oil sands

Oil sands or bituminous sands are a type of unconventional oil reserves that are found in about 70 countries around the world. Canada's oil sands reserves are one of the world's most vast hydrocarbon deposits situated almost entirely within the province of Alberta. These deposits are categorized based on geology, geography and bitumen content and mainly located in three principle areas: Athabasca, Peace River and Cold Lake. The three designated oil sands areas (OSAs) in Alberta are shown in Figure 2.1, which occupy an area of about 142 000 km<sup>2</sup> (ST98, 2012).



**Fig.2.1** Oil sands areas

*Source: Earth; an introduction to physical geology, 6th Edition, Tarbuck & Lutgens Prentice-Hall, 1999.*

Canada's oil sands resources contain a significant portion of the remaining oil resources in the world. Table 2.1 provides estimations by the Alberta Energy and Utilities Board (AEUB) of in-place volumes and established reserves of oil sands at the end of 2012. The AEUB

estimated that the initial volume in place for oil sands to be 293.1 billion cubic metres, from which 20.8 billion cubic metres are amendable to surface mining and the remaining 272.3 billion cubic metres are categorized as amendable to in situ recovery methods. The difference between in situ areas and surface mining is due to the thickness of the surface above the deposits, as it is considered a mining area if the thickness of the overburden is 75 metres or less (ST98, 2012).

**Table 2.1** In-place volumes and established reserves of oil sands at the end of 2012

<b>Billion m<sup>3</sup></b>	<b>Initial volume in place</b>	<b>Initial established reserves</b>	<b>Cumulative production</b>	<b>Remaining established reserves</b>
<b>Mineable</b>	20.8	6.16	0.82	5.34
<b>In situ</b>	272.3	21.94	0.47	21.46
<b>Total</b>	293.1	28.09	1.29	26.80

Source: ERCB- ST98, 2012

Oil sands are a mixture of quartz sand, silt, clay particles, water film and bitumen which have bonded and behave as a unit. Although there can be considerable variation, oil sands typically contain 75 to 80 percent inorganic material (NEB, 2000) from which 90 percent is quartz sand, 3 to 5 percent water and 10 to 12 percent bitumen with saturation up to 18 percent. The water in the oil sands is in three forms; it covers the sand particles as a 10 nm film, occupies the fines clusters, and appears as a ring among the particles (NEB, 2000). Figure 2.2 presents a schematic diagram of the Athabasca oil sands structure.

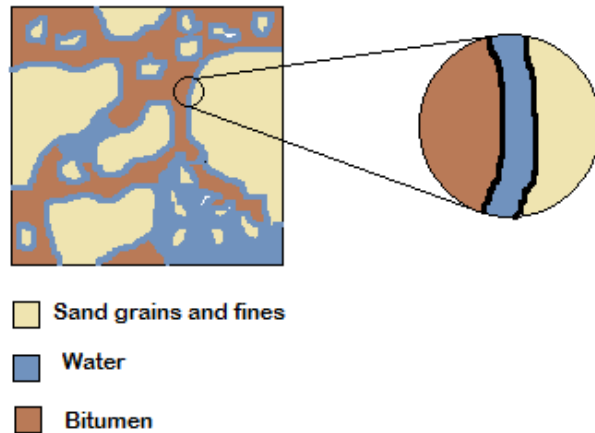

**Fig 2.2** Structural model of Athabasca oil sands

Based on NEB, 2000

The oil sands bitumen is trapped among the sand particles that are surrounded by a film of water. The bond between water and bitumen is weaker than that between sand and the water film, and as a result, the bitumen would be recovered faster. The clay components of oil sands have a major effect on the mixture behavior. The clay particles have an affinity to water and swell when hydrated; they also have a significant ion exchange capability. These characteristics play a noticeable role in the extraction and separation process of oil sands.

### **2.1.2 Oil sands bitumen**

The quality of oil sands reservoirs is based on the degree of saturation of the bitumen and the thickness of the saturated interval. With increase in the clay concentration and reduction in porosity, the bitumen saturation will decrease (ST98, 2012). The bitumen contained in the oil sands is very heavy and has a higher specific gravity than water which will result in the sinking of the oil into the water, unlike other types of oils (Chastko, 2004). In addition, crude oil has a very high viscosity, and high metal concentration and ratio of carbon to hydrogen in comparison to conventional oil (NEB, 2000). As a result, oil sands bitumen will not flow like other oils, thus making the extraction a difficult and complicated process.

## **2.2 Review of oil sands extraction technology**

### **2.2.1 Introduction**

From the first extraction attempts to the present day, the oil sands industry has significantly developed and improved, and Canada has played a considerable role, which has made the country a world leader in oil sands development. Many mining and upgrading methods that are employed today are the result of important innovations put into action in the 1990s (NEB, 2000).

### **2.2.2 Mining**

Depending on the thickness of the surface layer or the depth of the deposits, one of two recovery methods is used to recover the oil.

### **2.2.3 Open pit mining**

In cases where the deposits occur close to the surface, such as north of the Fort McMurray (Athabasca OSA), the open pit mining method is used. As the first step in this surface

mining method, water laden muskeg and layers of muskeg and surface vegetation are removed. The overburden under the muskeg consists of rock, sand and clay, which are removed to reveal the oil sands deposit underneath. The ore is moved to a cyclofeeder by using large mining trucks and power shovels. In the cyclofeeder, oil sands are crushed and mixed with hot water to create slurry that is transferred to a pipeline. Later, the slurry is transported to an extraction plant (NEB, 2000).

#### **2.2.4 Hot water process**

Due to the specific characteristics of oil sands bitumen, conventional extraction methods are not applicable and an alternative method is required to recover the oil. A hot water process (HWP) that is used by oil sands companies to extract bitumen was developed by Dr. Karel Clark in 1939. A typical commercial HWP plant is depicted in Figure 2.3, where oil sands ore is pumped into a large rotating tumbler and hot water (85°C) and a caustic substance (sodium hydroxide (NaOH)) are added to the tumbler. Hot water provides a proper condition for clays to swell and with the help of NaOH, bonds between components are weakened and removed. Later, the slurry is moved through vibrating screens to remove the rocks, coarse particles and clay lumps. In the separation cells, bitumen micelles are united and rise to the surface as froth, where it is skimmed off and separated from the settling sand. The bitumen froth is pumped into a solvent extraction plant and mediocre stream is removed from the froth. In the next step, the froth, which is rich in water and mineral matter, enters the scavenger cells for recovery through a froth settler. A diluent, in this case, naphtha, is added, and the mixture enters a high speed centrifuge to finish the froth treatment and complete the separation. The coarse mineral matter from the primary and secondary separation cells are combined with those from the scavenger units and directed towards tailings oil recovery (TOR). The residual oil trapped in the tailings can be recovered by a TOR system before directing them towards the tailings ponds while the diluent bitumen is transferred to an upgrading site.

In the upgrading unit, the oil sands recovered bitumen is converted into a high quality synthetic crude oil with characteristics similar to conventional crude oil. This is achieved by coking, desulphurization and hydrogen addition to the tar-like viscous bitumen. Upgrading starts by recovering the naphtha and coking in high temperature to crack the long bitumen molecules. Because of the high temperature in coker reactors, most of the bitumen is vaporized into gas

while the heavy carbon rich material forms coke and is separated for use in other industrial applications.

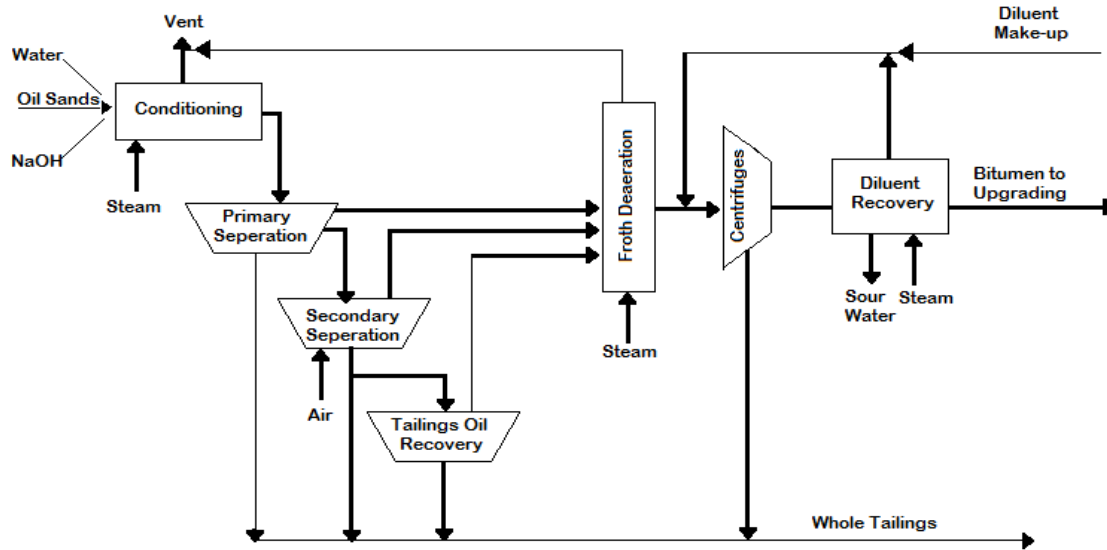

**Fig. 2.3** A typical commercial HWP plant

*Based on National Energy Board (NEB), 2000*

Fractionators separate the remaining hydrocarbon vapors into naphtha, kerosene and gas oil that are sent to hydrotreater units. High temperature and high pressure inside these units with the help of a catalyst create the optimum condition for hydrocarbon vapors to react with hydrogen. As a result, sulphur and nitrogen are removed, and the stream is stabilized. By combining the resulting stream of naphtha and gas oil, high grade crude oil is created with lower density and viscosity compared to first stage extracted bitumen. By using the HWP, 88 to 95 percent of the bitumen can be recovered depending on the grade and origin of the oil sands (OSRIN Report, 2010).

### 2.2.5 In situ recovery

It is not economically feasible to extract oil sands in reservoirs that are covered with a thick surface layer through surface mining; as a result, in situ mining operations are used for deep deposits. It has been estimated that more than 80 percent of Alberta’s oil sands deposits are recovered by the in situ technique, which is almost 39 billion cubic metres (NED, 2000). The extent of deep reservoirs shows the significance of the in situ recovery technology.

Several in situ recovery methods have been tested on Alberta's OSAs, either alone or in combination with other techniques. By using these methods, specific temperatures and pressures are applied to allow the bitumen to flow like other types of conventional oils. As a result, the less viscous bitumen is directed towards the wells. In situ recoveries are applied by using both primary development and enhanced developments (ST98, 2012). Primary development techniques are similar to those that are used in extracting conventional oil. Enhanced development contains several methods that are specifically used for deep viscous reservoirs, and cyclic steam stimulation (CSS) and steam-assisted gravity drainage (SAGD) are the two main methods of this technique.

### **1. Cyclic steam simulation**

CSS was commercialized in 1985 and is a steam based method that produces huge amounts of steam by using large boilers. Steam is injected down the well bore towards the reservoir, thus creating an average temperature of 300° C and pressure around 11,000 kPa (NED, 2000). This range of applied pressure would fracture the rocks to create paths for the bitumen. On the other hand, high temperature would reduce the viscosity of the bitumen, thus allowing the bitumen to flow. Each cycle takes six to eighteen months, starting with steaming followed by soaking and production. By using this method, 20 to 25 percent of the bitumen will be recovered.

### **2. Steam assisted gravity drainage**

Slow production rates due to the discontinuous process of CSS were the motivation to develop a continuous system of heating and production. In 1978, the first steam assisted gravity drainage (SAGD) test was conducted at Cold Lake (NED, 2000). This system contains a network of vertical access shafts and horizontal wells that penetrate through the oil sands deposits. Wells are placed through the vertical tunnels and each pair of wells consists of a producer and an injector. The steam is injected through the injector well located at five metres above the reservoir and heats up the viscous bitumen. Thinner bitumen will penetrate through the soil and move to the producer well at the base of the deposits. At the final step of the SAGD system, the bitumen is pumped to the surface and transferred to the upgrading section. The SAGD system provides up to 60 percent of the recovery factor in the first phase (NED, 2000). In addition, a lower steam oil ratio results in the reduction of operating costs.

## 2.3 Mature fine tailings

Reservoirs that are recovered by using surface mining are mainly located in northern Alberta and the HWP is the dominant extraction method. The HWP produces huge amounts of slurry tailings that are hydraulically transported and stored within surface tailings ponds. The high water content tailings are composed of sand, silt, clay particles and residual bitumen, with 45 to 55 percent solids (Chalaturnyk et al., 2002). After deposition, sand and almost half of the fine particles (mineral particles smaller than 44  $\mu\text{m}$ ) settle quickly and are removed from the rest of the slurry. The remaining water, fines and residual bitumen are transferred to the surface tailings ponds with approximately 8 percent solid content (OSRIN Report, 2010). After 2 to 3 years, the tailings consolidate at the bottom of the tailings pond to a solid content of 30 percent (Johnson et al., 1993). Tailings that have a solid content of 30 percent behave like a liquid and will stay in this state for decades, up to 150 years, due to the slow consolidation rate (Kasperski, 1992).

As a result, a suspension called MFT is formed with virtually no further consolidation. MFT is a mixture of residual bitumen, sand, silt, fine clay particles and water, and the clay content varies from approximately 8 to 25 percent, and the solid content generally ranges from 35 to 65 percent. A strong suspension is created as a result of different chemical and physical properties (Chalaturnyk et al., 2002), such as:

1. Water-soluble asphaltic acids that remain in the tailings due to the residual bitumen. This material will decrease the surface and interfacial tension of the water and acts as clay dispersants.
2. Ultrafine clay particles (less than 0.2  $\mu\text{m}$ ) that retain large amounts of water by forming a gel like structure within the MFT.
3. A strong card-house clay structure which is created based on the existence of organic material on the surface of the clay particles. The strength of this structure depends on the pH of the slurry. By increasing the pH to over 10, the amount of  $\text{OH}^-$  will also increase and will result in collapse of the structure. The same outcome is derived by reducing the pH to lower than 6.

These characteristics will result in poor water release ability, poor consolidation, low permeability and low strength. Therefore, tailings dewatering under natural conditions is not an option and other types of solidification methods should be considered. As the first step after the production of MFT, they are stored in huge surface tailings ponds. It is estimated that currently more than 170 km<sup>2</sup> of Alberta's lands are covered by tailings ponds and they are expected to expand nearly 50% in size by 2020, thus occupying an area of 250 km<sup>2</sup> (Government of Alberta, June 2012).

## **2.4 MFT properties**

### **2.4.1 MFT mineralogy**

One of the most important characteristics of MFT is their mineralogy which helps to predict their behavior under different conditions. MFT consist of sand, clays, amorphous oxides, and trace metals (Mikula et al., 1996). Sand particles are 97.5-99% SiO<sub>2</sub>, 0.5-0.9% Al<sub>2</sub>O<sub>3</sub>, and 1-0.9% Fe. The majority of the clays that build the MFT comprises kaolinite and illite, with traces of smectites, chlorite, vermiculite, and mixed layer clays (Mikula et al., 1996). Although the amounts and types of clay minerals found in tailings ponds vary considerably, kaolinite and illite are predominantly clay minerals. Heavy metals detected in the oil sands tailings of Alberta are: Ti, Zr, Fe, V, Mg, Mn, Al, Pb, Zn, Nb, and Mo. Analyses of MFT by both Syncrude and Suncor show about 1-5% Fe and trace amounts of Al and Si oxides, although these amounts vary with depth (Mikula et al.,1996).

### **2.4.2 Composition of MFT pore water**

Water constitutes a major portion of tailings and its composition has a significant influence on the structure of tailings and their production. Water moves through the fine tailings structure by hydraulic conductivity and permeability, and contains organic and inorganic ions (Mikula et al., 1996). The main sources of the inorganic ions found in tailings water are:

1. Oil sand innate water which contains NaCl, and small amounts of K, Ca, Mg, and SO<sub>4</sub>.
2. Water taken from the water supply.
3. Chemicals added during the HWP.

In addition to inorganic ions, some fractions of organic components exist in the tailings water, which are released during the HWP (Mikula et al., 1996).

## 2.5 Tailings ponds

Slurry tailings with high water content are pumped and stored in tailings ponds as the provincial law strictly prohibits the release of water that has been in contact with bitumen, into water bodies of the mine site. A sketch of an MFT tailings pond is shown in Figure 2.4. Within the ponds, coarse particles start to settle and form a layer at the bottom of the pond (2). Very fine particles, such as clay and fine silt, remain in floatation in a thin layer called fluid fine tailings (3). This suspension is not strong and the water would eventually settle into the lower layer called the MFT (4) (Government of Alberta, 2009).

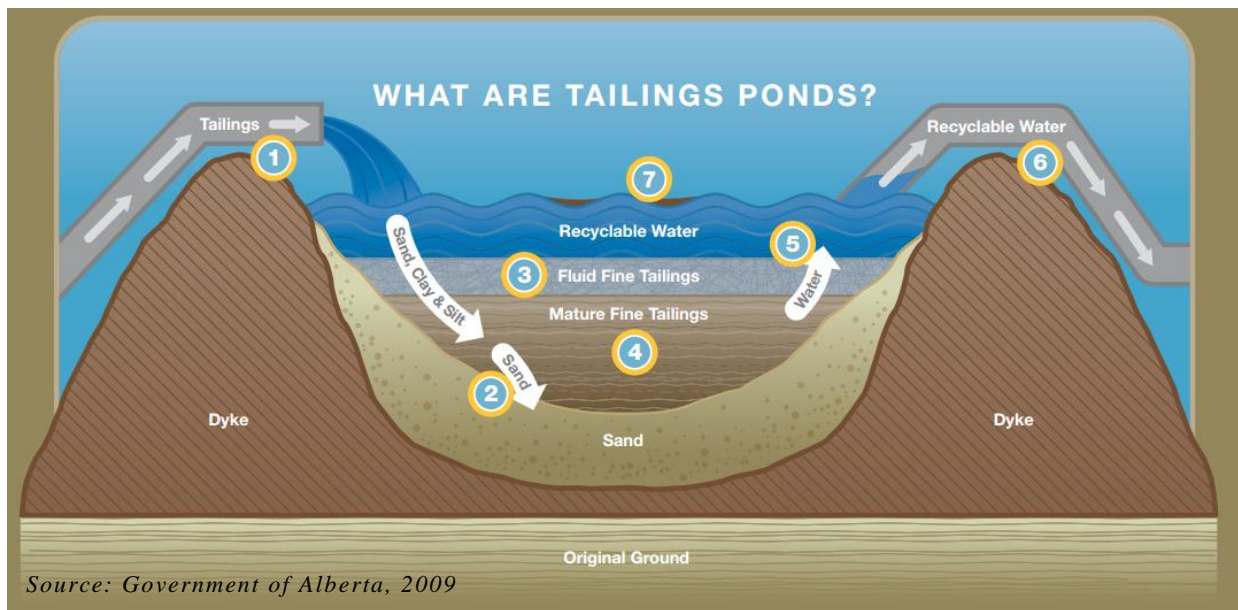

**Fig.2.4** MFT tailings pond.

The MFT layer is heavier than the fluid fine tailings due to a higher solid content. The MFT creates a strong suspension that allows fines to float and remain in the fluid. In addition, clear water will separate from the tailings and rise to the surface of the tailings pond (5), thus creating the opportunity to recover and reuse the wasted water (6). Some residual bitumen will also separate from the tailings and float on the surface of the water (7).

By increasing the amount of produced MFT and the need for more tailings ponds, tailings management remains one of the most difficult and important issues that concern the oil sands industry.

## **2.6 Environmental issues of MFT**

Certainly the storing of MFT in tailings ponds is not a long term solution for the oil sands industry, due to the nature of MFT and harmful effects of tailings ponds on the surrounding environment. This study adopts the information provided by an expert panel of the Royal Society of Canada (RSC) which has singled out the major concerns of tailings ponds and their impacts on the environment and public health.

### **2.6.1 Impacts of tailings ponds on land use**

Currently, more than 170 km<sup>2</sup> of Alberta's lands are devoted to tailings ponds (Government of Alberta, June 2012) and this number is quickly increasing due to the production of approximately 25 million cubic metres of MFT each year (Johnson et al., 1993). The main issue is the very low strength of MFT that cover these areas as they are not trafficable and will not allow reclamation.

### **2.6.2 Impacts of tailings ponds on regional water supply**

All aspects of oil sands development are dependent on water and huge amounts of water are used during the extraction process. Although some of the water is recovered during extraction and some are regained from the surface of the tailings ponds, the produced slurry tailings have high water content. Almost 60 to 80 percent of the produced MFT is water that is trapped among the fine particles. In considering the quantity of produced MFT, a sizable amount of water is kept in tailings ponds that can be reused in the HWP or returned to the source. Therefore, the dewatering of MFT would significantly contribute as waste water management in the area, specifically in terms of the regional water supply.

### **2.6.3 Impacts of tailings ponds on regional and ground water quality**

Oil sands tailings water contains toxic constituents that are harmful to aquatic organisms and affect the water quality of the regional water resources. Although the water release ability of MFT is poor, even small amounts of released water can pollute the surrounding water supplies.

Naphthenic acids (NAs) are a constituent of particular concern as they are a natural component of petroleum that has evolved through the oxidation of naphthenes (Rogers et al., 2002). Given the long term toxicity and magnitude of NAs, they are considered a significant water quality hazard in the foreseeable future (Gosselin et al., 2010).

#### **2.6.4 Impacts of tailings ponds on air quality**

Greenhouse gas (GHG) emission from tailings ponds has been reported in many MFT sites located in northern Alberta (Fedorak et al., 2003, Holowenko et al., 2000). One of the most significant studied areas is the Mildred Lake Settling Basin (MLSB) operated by Syncrude, where methane bubbles were found almost 20 years after starting the operation with an estimated daily flux of 12 g CH<sub>4</sub>/m<sup>2</sup>/d in the most active areas (Holowenko et al., 2000). Studies carried out by Holowenko et al. in 2000 and Fedorak et al. in 2003 demonstrate that the presence of methane gas in tailings ponds will:

1. Provide faster transport of toxic compounds to the capping water.
2. Reduce the oxygen level of lakes.
3. Produce toxic compounds, such as ethylene.
4. Affect plant growth.
5. Reduce reclaimed ecosystem function.
6. Slow down remediation efforts (Yeh et al., 2010).

One of the major environmental concerns in oil sands tailings management is to separate water from the MFT to increase the strength and densification of the tailings, thus providing optimum conditions for reclamation.

#### **2.7 Oil sands tailings management**

The main objective of oil sands tailings treatment is to dewater and consolidate fine tailings to create a trafficable load bearing surface. In the process of treatment, time and expense are two important factors as part of the evaluation of the dewatering technique. The Energy Resource Conservation Board (ERCB) in 2009 published Directive 079 which provides information about oil sands tailings performance criteria and requirements. The purpose of this directive is to regulate tailings operations and management associated with oil sands with two

main objectives; that is, to reduce DDAS and produce trafficable deposits. Accordingly, the following criteria must be achieved annually:

1. Deposited material should show minimum undrained shear strength of 5 kPa after one year of deposition.
2. Remaining deposited material that does not meet the 5 kPa requirement after one year, should be removed or remediated.
3. Deposited material should present enough strength, stability, and structure necessary to establish a trafficable surface with 10 kPa undrained shear strength after 5 years of deposition.

DDAS should be monitored and examined annually and the results should be reported to the ERCB to ensure that the Board (ERCB Board) can hold mineable oil sands operators accountable for tailings management. Operators are allowed to use different dewatering and densification methods for obtaining the required criteria. Directive 079 follows seven long-term objectives with respect to tailings management:

1. to minimize and eventually eliminate long-term storage of fluid tailings in the reclamation landscape;
2. to create a trafficable landscape at the earliest opportunity to facilitate progressive reclamation;
3. to eliminate or reduce containment of fluid tailings in an external tailings disposal area during operations;
4. to reduce stored process-affected waste water volumes on site;
5. to maximize intermediate process water recycling to increase energy efficiency and reduce fresh water import;
6. to minimize resource sterilization associated with tailings ponds; and
7. to ensure that the liability for tailings is managed through reclamation of tailings ponds.

## **2.8 Tailings treatment technologies**

During last 40 years, several different dewatering methods have been introduced and implicated so that the resulting MFT are no longer mobile and do not need surface pond storing

(OSRIN Report, 2010). Some of these techniques are still being used and some of them have remained at the laboratory scale due to different limitations. These techniques are categorized into five different groups:

1. Chemical or biological amendments
2. Physical or mechanical processes
3. Natural processes
4. Mixtures/co-disposal
5. Permanent storage

The following are some of the methods for each group and case study reviews. In reviewing these techniques, it should be considered that the research is focused on finding a scheme that uses more than one technology. In other words, with no unique technology, the optimum result is to be found by combining these techniques.

### **2.8.1 Chemical or biological amendments**

#### **Thickening process (past technique)**

Thickened tailings (TT) technology is a dewatering process for slurries with low solid content that involves the sedimentation of suspended fines with the help of chemicals. Therefore, thickened tailings are defined as highly densified tailings that form a non-segregated mixture (Fourie, 2008). TTs are created within a vessel called thickeners that separate the tailings stream with cyclones (WWF-Canada, October 2010).

**Thickeners:** sedimentation units that come in a variety of sizes and configurations. Thickeners are generally defined by the method of the derived support system, or how the tanks are powered. Overall, there are four major categories of thickeners:

1. Bridge mounted
2. Centre mounted
3. Traction driven
4. Caisson thickener (Jewell and Fourie, 1999).

Tailings will pass through a particular or free settling, then through hindered settling, then to the compression settling at the bottom portion of the thickener (Fourie, 2008). These processes will separate the tailings into a coarse sand underflow and a fluid fine tailings overflow (WWF-Canada, October 2010). Water and fine particles are mainly gathered in the overflow that is later treated by adding polymer to obtain approximately a 30% solid content.

**Flocculants in thickening:** flocculants are organic, high molecular weight synthetics or natural polymers that help to enhance the settling rates of most suspended solids by adsorbing onto solid particles, bringing them together into a floc (Barbour and Wilson, 1993). Flocculants are commonly used in thickening processes to increase the settling rate and decrease the thickener size (Jewell and Fourie, 1999).

Grain size distribution and variation of the size of thickened tailings throughout ponds have significant effects on their behaviors within tailings deposits. As shown in a study by Barbour and Wilson (1993), thickened tailings can be classified as non-plastic silt with a silt content of 45 to 70 percent. Figure 2.5 provides the grain size distribution of TTs from various parts of a tailings pond.

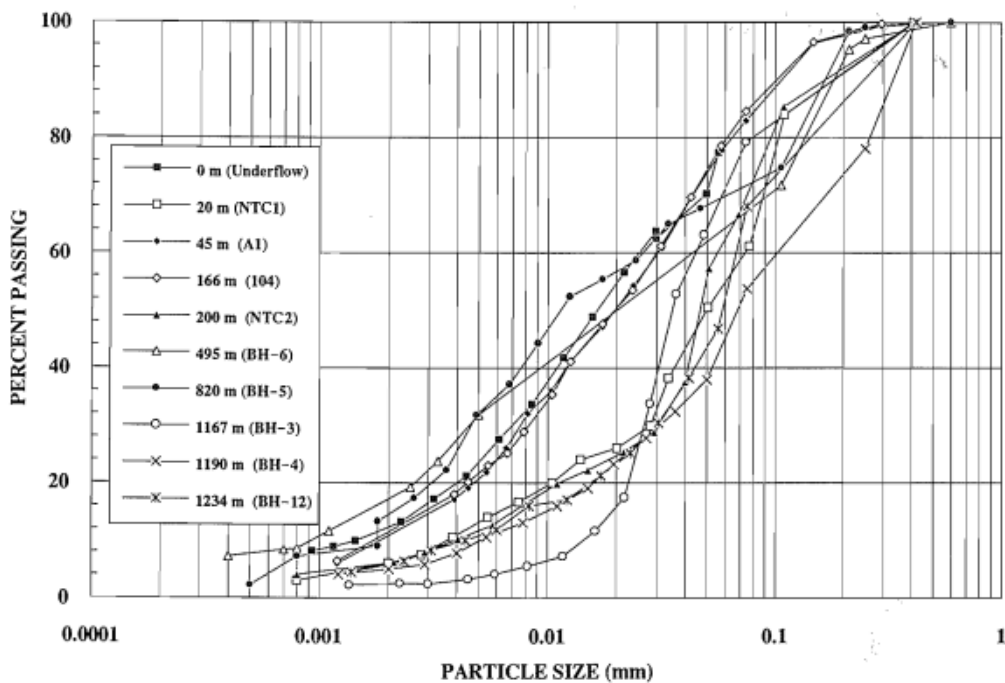

**Fig. 2.5** Particle-size distribution curves for various samples of thickened tailings.

*Source: Barbour and Wilson, 1993.*

The uniformity of grain size results in consistent characteristics and behaviors (permeability, water release ability and consolidation) in the ponds regardless of the distance from the point of discharge (Barbour and Wilson, 1993).

By using this method, tailings would gain consistency as the resultant MFT, as produced, rather than waiting for settlement under gravity and the water can be recovered faster. The typical spent time for creating MFT with a 30% solid content in a thickener vessel is half an hour, which is a significant improvement, compared to the 1 - 3 years that is usually reserved for settlement under natural conditions (OSRIN Report, 2010). Another advantage of the TT technology is that it saves energy by recovering the heat energy which will reduce GHG emissions (WWF-Canada, October 2010).

The following are some advantages and disadvantages of the TT technology used in the oil sands industry (OSRIN Report, 2010).

#### ***Advantages***

1. Quick dewatering.
2. Recovering used water and heated energy.
3. More stable deposits.
4. Resultant MFT would require less land.
5. Fine particles are captured with sands and not available to form more MFT.

#### ***Disadvantages***

1. ERCB requirements are not met and further treatment is needed.
2. High cost and large number of educated operators are required.
3. Tailings can only be stacked in slopes of 0.5% to 1%.
4. Accumulation of coarse materials at the thickeners feedwell will affect the application.

#### **Whole tailings flocculation**

Whole tailings flocculation is the process of removing colloidal-sized particles with the help of a reagent. In this method, a flocculant is added to the tailings to generate composite

tailings. Flocculation would create bonds between colloids to neutralize and counterbalance the charges of particle groups (OSRIN Report, 2010). New loosely bonded agglomerates are called flocs that would destabilize the suspension and settle at the bottom of a vessel or tailings pond. Currently, three groups of flocculants are used (OSRIN Report, 2010):

1. Minerals such as silica, bentonite, alum and ferrichydroxide
2. Natural flocculants, such as starch derivatives
3. Synthetic flocculants, such as polyacrylamides.

A study by Chalaturnyk et al. (2002) showed the characteristics of fine tailings treated with a combination of two different flocculants. In the beginning of the process, hot fresh tailings were treated with  $\text{Ca(OH)}_2$  and later,  $\text{CO}_2$  was added, which resulted in the formation of  $\text{CaCO}_3$  by using the following equation:

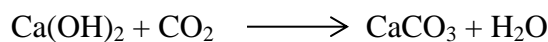

$\text{CaCO}_3$  would absorb the ultrafine particles suspended in the liquid and precipitates. One important aspect of  $\text{CaCO}_3$  particle absorption and precipitation is the temperature of the environment. This process can be improved by increasing the temperature and the discharge HWP (70°C) would provide an optimum platform for the precipitation of  $\text{CaCO}_3$ . Experiments were performed by using “desanded thickener feed” tailings (tailings that were desanded by thickener), composed of 8.5 wt% solids, 56.6 wt% of which are fines (<44 μm). The sample had a viscosity of 2 cp and a pH of 8.5 at room temperature (20°C).

By adding CaO to the tailings, the pipe viscosity and pH of the tailings would increase as presented in Figure 2.6. This increase in the viscosity is an indication of flocculation of the clay which is caused by  $\text{Ca}^{2+}$  and  $\text{OH}^-$  (Chalaturnyk et al., 2002).

The treatment of tailings by  $\text{Ca(OH)}_2$  and later with  $\text{CO}_2$  have a significant effect on their settlement characteristics. Changes in pH as a result of adding  $\text{CO}_2$  reduce the pH from 12 to 11.6, which is an important aspect of settlement. The settlement rates of the desanded tailings treated with flocculants are shown in Figure 2.7.

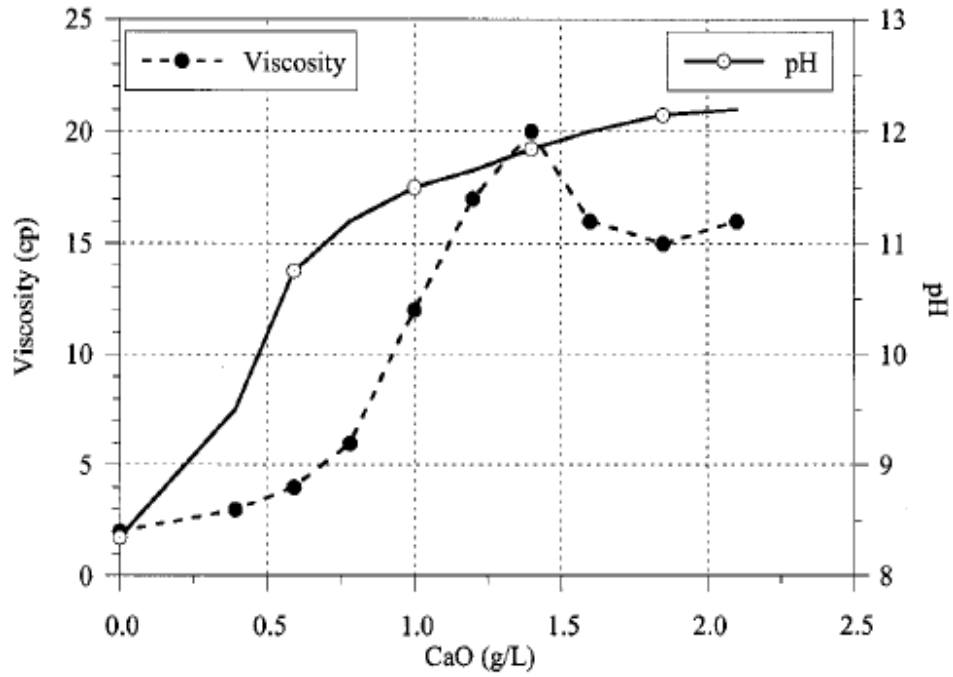

**Fig. 2.6** pH and viscosity of desanded thickener feed tailings sample at 70°C as a function of CaO dosage (Chalaturnyk et al., 2002).

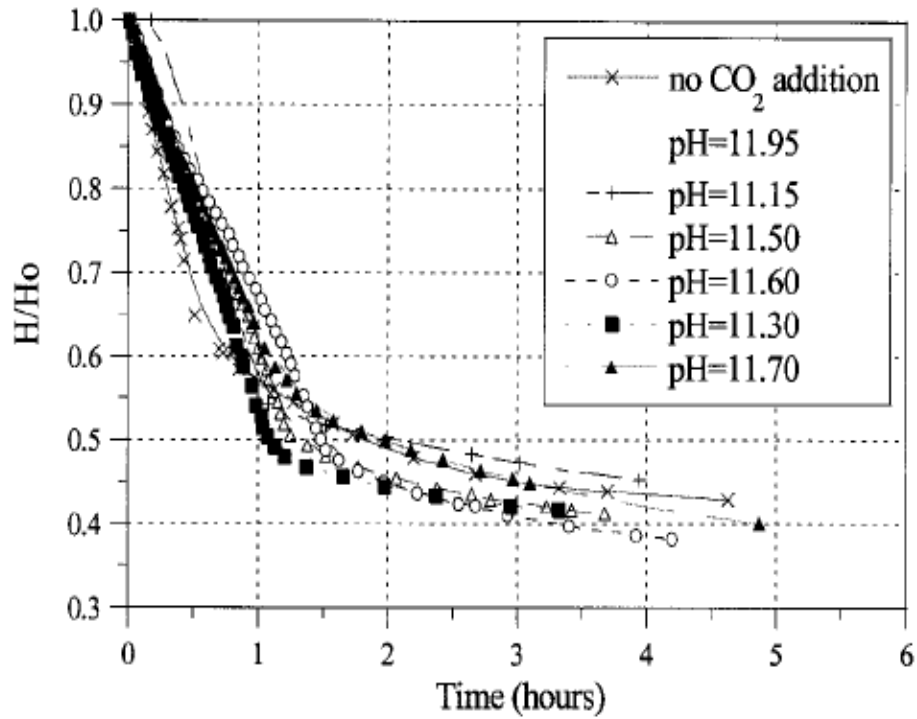

**Fig. 2.7** Sedimentation rate of desanded thickener feed tailings sample treated with Ca(OH)<sub>2</sub> lime and CO<sub>2</sub>, for about 5 h at 70°C (Chalaturnyk et al., 2002).

Some advantages and disadvantages of this technique are (OSRIN Report, 2010):

### *Advantages*

1. Large amounts of water are recovered.
2. A variety of flocculants that can be chosen based on practical and economic feasibility.
3. Resulting material suitable for vacuum or pressure or building beaches and slopes.
4. The entire process would take place in a short amount of time (from days to weeks).

### *Disadvantages*

1. ERCB requirements are not met and further treatment is needed.
2. May need to be used with coagulants.
3. High cost of the operation.

## **2.8.2 Physical or mechanical processes**

### **Centrifuge fine tailings**

A centrifuge will apply a thousand times gravity force to separate particles from liquid and involves two steps of separation. In the first stage, a horizontal solid bowl centrifuge is used along flocculants to form two streams; very high water content slurry with 0.5 to 1 wt% slurry and a cake with up to 60 wt% solids. For the second step, the created cake would undergo further natural dewatering, such as evaporation and freeze/thaw (OSRIN Report, 2010).

The results of the laboratory and bench scale tests have turned out to be promising and encouraging. Therefore, the commercial application of the centrifuge fine tailings technology has started in 2012 (OSRIN Report, 2010). The following are some advantages and disadvantages of this method (OSRIN Report, 2010).

### *Advantages*

1. Addresses legacy MFT.
2. Recovers large amounts of water.
3. Cake with 60 wt% solids is created within a short amount of time (in days).

4. Resulting material is trafficable and speeds up the reclamation process.
5. Process requires fewer operators and labour compared to other methods.

### *Disadvantages*

1. High starting cost.
2. Transportation of generated cake can be challenging.
3. Although the process requires fewer operators, higher skilled and experienced operators are needed.
4. Trafficability of the layer may be an issue at a large scale.

### **Filtered whole tailings**

As one of the basic methods, the filtration of unaltered tailings stream results in filtered whole tailings. Filtration takes place by using pressure or a vacuum (OSRIN Report, 2010) in a way that coarse and medium particles are separated from water. Pressure filters consist of horizontal or vertical plates and vacuum filters contain series of drums and horizontal belts. In the case of MFT filtration, pressure filters are commonly used for their ability to filter a wider spectrum of materials (OSRIN Report, 2010).

The accumulation of solids at the back of the filtration plates creates a filter cake with a significantly high solid content. The hydraulic conductivity and permeability of the produced cakes are important parameters that determine the quality and duration of the filtration. At the end of the filtration process, the filter cakes are removed for disposal or reuse in a site.

The main issue associated with tailings filtration is the large amount of tailings and creation of extremely low hydraulic conductivity with the filtration plates. The latter can be resolved by adding coagulants or flocculants (OSRIN Report, 2010) to increase the flocculation of the particles and increase the hydraulic conductivity.

The filterability of MFT highly depends on the fine content of the tailings. MFT with less fine particles present a sharper filtration curve and it was estimated that the filtration of MFT with more than 4 wt% fine particles is unpractical (Xu et al., 2008). In considering the fact that MFT have up to 18% fine content (OSRIN Report, 2010), it is necessary to add flocculants to create turbulence in the suspension.

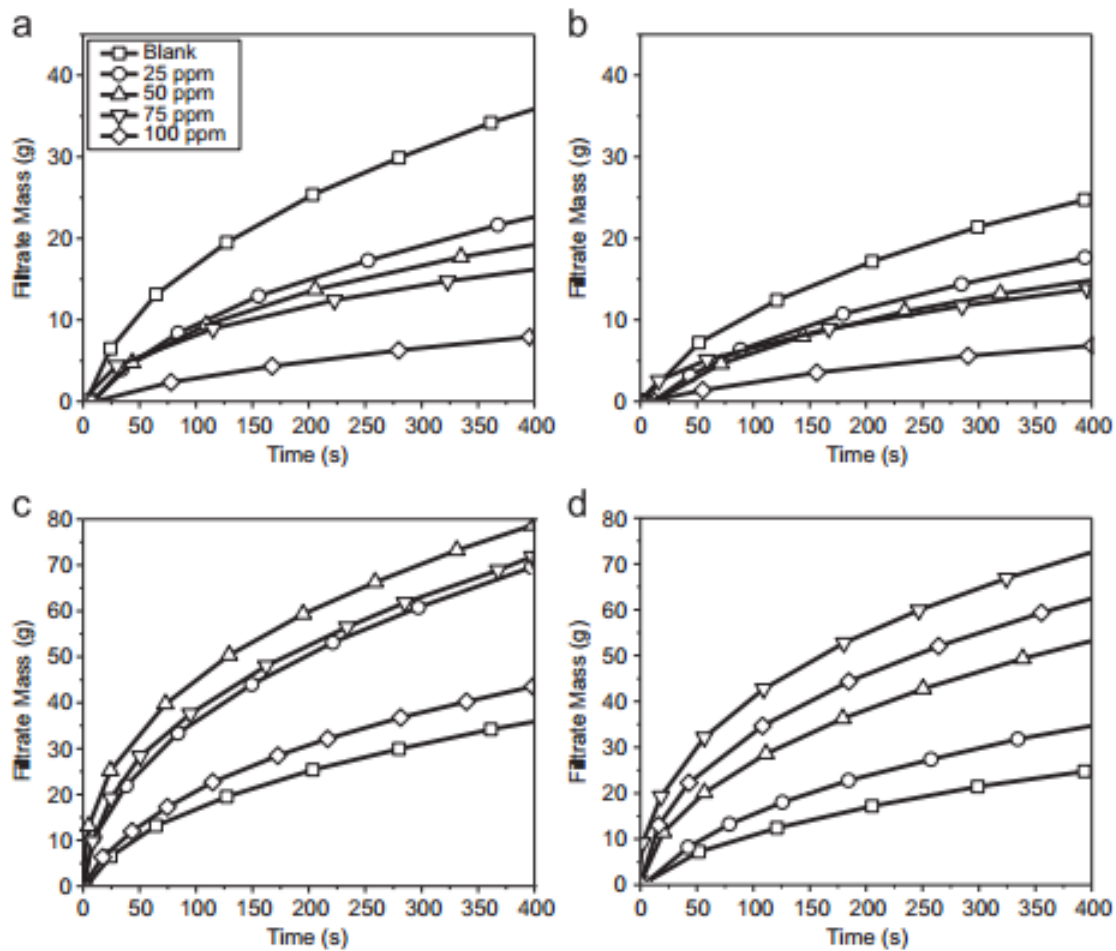

**Fig.2.8** Filtration curves of MFT diluted to 5 wt% and 10 wt% solids, by using Magnafloc (a and b) and Al-PAM (c and d) as filtration aids. (a) 5 wt%, (b) 10 wt%, (c) 5 wt% and (d) 10 wt% (Alamgir et al., 2012)

It is basically impractical to filter MFT with 30-40 wt% solids and the diluting of the MFT is carried out to reduce the solid content of the MTF. Alamgir et al. (2012) showed that flocculants cannot improve the settling and filtration of MFT with 31 percent solid content and even dilution to 15 wt% would not have any improvement on the filtration results. Figure 2.8 presents the results of Alamgir et al. (2012) for the filtration of MFT diluted to 5 wt% and 10 wt% solids with two different polymers as the flocculant. The results illustrate that for both types of flocculants, MFT with lower solid content presents better filtration results and less resistance to filtration (FTR) in the same time period.

Several tests and studies have been carried out to improve the filterability of MFT and many were unsuccessful due to the nature of the MFT, large volumes of tailings and insufficiency of the designed systems. As a result, the filtered whole tailings method has never been carried out to maturation. Some of the advantages and disadvantages of using the filtered whole tailings technology are as follows (OSRIN Report, 2010).

#### *Advantages*

1. High recovery of used water.
2. Significant reduction in size of disposal material.
3. Storing of produced material easier and requires less space.
4. Low moisture content of produced material reduces environmental impacts.

#### *Disadvantages*

1. High cost.
2. Filtered tailings are no longer pump able.
3. Legacy tailings cannot be treated by using this method.

### **2.8.3 Natural processes**

#### **Freeze/Thaw**

Freeze thaw dewatering is a natural process that happens multiple times a year (depending on the climate region of the area). MFT are stored in thin layers that become frozen when the temperature is low enough and the separated water will drain from the layers when thawing takes place. The mechanism of separating the solids and the water starts with the formation of the first ice aggregate which produces a negative pressure. As a result, a strong suction drives the water in the tailings slurry towards the forming ice. The moving mass of water would create a network of paths throughout the layers that would be used as draining channels while thawing. Therefore, during the freezing process, water is separated from the solids in the form of ice and during the thawing process, will drain from the layers.

The process of a closed system of freeze thaw can be explained by presenting void ratio versus effective stress as shown in Figure 2.9 (Dawson et al., 1999). One can assume a fine

grained slurry in the pond that is undergoing a small effective pressure, located at Point A in the curve. The materials are removed from the pond to a point with zero effective stress and swell marginally to Point B. At this point, slurry is frozen and expands to Point C with no effective stress. The change in volume from B to C is due to the formation of ice in the pore space of the slurry and the expansion of the water volume while freezing. During the thawing process, the ice melts and the volume would decrease to Point D. The volume change and transformation from B to D are known as the thawing strain (Dawson et al., 1999).

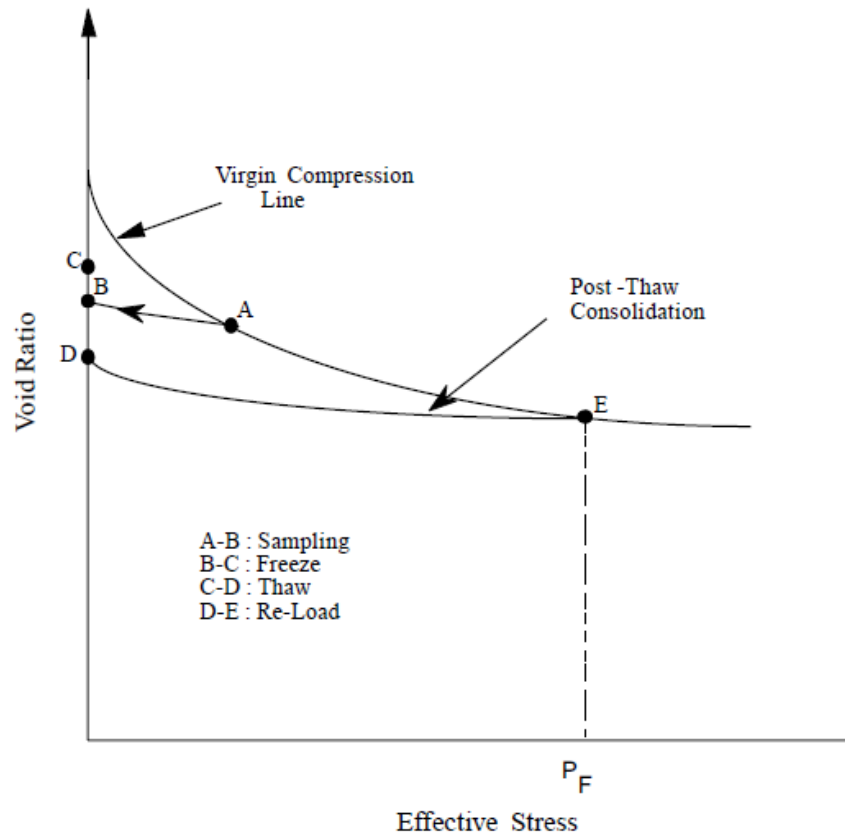

**Fig. 2.9** Freeze–thaw dewatering mechanism (Dawson et al., 1999)

By using this method, the solid content of MFT will increase from 30 to 50 percent and by increasing the number of cycles, another 10 percent improvement can be achieved (Johnson et al., 1993). Also, the effect of the freeze/thaw method can be enhanced by using chemical means and combining other dewatering methods.

Currently, freeze/thaw dewatering is used in several ponds at a commercial scale combined with other methods, such as drying, to improve the densification of the produced MFT. The following are some of the advantages and disadvantages of this method (OSRIN Report, 2010).

### *Advantages*

1. Low cost.
2. Does not require specifically trained operator.
3. Addresses legacy MFT.
4. Allows for other types of treatment to be carried out at the same time.

### *Disadvantages*

1. Labour intensive.
2. Requires a large area to deposit the thin layers.
3. Takes a long time and highly dependent on the weather conditions of the area.

## **2.8.4 Mixtures/co-disposal**

### **Composite/consolidated tailings**

Another process for increasing the speed of water release for fine tailings is through the use of nonsegregating tailings (NST). This method solidifies fine tailings by adding flocculating chemicals to produce a NST slurry referred to as composed tailings (CT). The addition of  $\text{Ca}^{2+}$  to MFT brings coarse particles into the suspension. The newly created suspension is less durable and the coarse particles start to settle in a short period of time while they catch the fine particles along the way and force them to settle (Caughill et al., 1993).

Different flocculants are used as the source of Ca, such as lime ( $\text{CaOH}_2$ ) and gypsum ( $\text{CaSO}_4$ ). By using these materials, the boundary line for the formation of NST is shifted toward a lower solid concentration (Chalaturnyk et al., 2002).

Although the use of CT has been a primary tailings management technique for many years and also commercially used, the process is still under review (OSRIN Report, 2010). The following are some advantages and disadvantages of this technique (OSRIN Report, 2010).

### *Advantages*

1. Low cost.
2. Addresses legacy tailings.
3. Can be implemented at a large scale.
4. Short treatment time and allows for land reclamation.

### *Disadvantages*

1. Low energy efficiency.
2. Careful engineering and operation are required to prevent segregation during deposition.
3. Large containment required until tailings become solid.
4. Produces additional MFT from cyclone overflow.

## **2.8.5 Permanent storage**

### **Water capping**

In this method, fresh water is used as a layer over the deposits of fine tailings in order to form a lake and has been successfully demonstrated in Alberta's tailings ponds. In this reclamation option, the fine tailings materials that remain as fluid are deposited into geotechnically and hydrogeologically secure areas. As a result, the MFT will be capped with a layer of water with a sufficient depth to prevent mixing of the layers and allow the formation of a stable self-sustaining lake ecosystem that is isolated from direct contact with the surrounding environment (OSRIN Report, 2010). Research has shown that these lakes will evolve into natural ecosystems, and over time, support healthy communities of aquatic plants, animals and fish (OSRIN Report, 2010). Figure 2.10 shows the test ponds that were formed in 1989.



**Fig.2.10** Water cap tailings test ponds

The water used in these ponds can be natural surface water or the processed water. The depth of the water changes through time, starting from 5 metres and increases as the MFT layer underneath consolidates. Many studies and tests at the laboratory and the field scale have been carried out on water capping as a remediation method for MFT, and have considered the different aspects of this method. The following are some positive and negative aspects of using water capping to deal with MFT (OSRIN Report, 2010).

### ***Advantages***

1. Low cost.
2. Creates self-sustainable aquatic system.
3. Natural microbial process of system would eventually reduce contaminant concentration.
4. Preserves environment.

### ***Disadvantages***

1. Biological activity in fluid tailings may emit considerable gas, which may result in mixing fluid tailings with overlying water.
2. Limitations for areas where water cap tailings lakes can be located.
3. Some uncertainties about the future of the created ecosystem.

## 2.9 Super absorbent polymer

SAPs are categorized as hydrophilic gels (hydrogels) which have a network of polymer chains in which water is a dispersion medium. SAPs can absorb and retain extraordinarily large amounts of water or any aqueous solutions relative to their own mass (Zohuriaan-Mehr and Kabiri, 2008). A typical granular SAP is shown in Figure 2.11. The high absorption capacity of these materials is a result of their significant swelling capacity that helps to retain large amounts of water. During the past 15 years, SAPs have been used and implicated in several industries and products, and now today, a variety of applications are dependent on SAPs. The global production of SAPs is over 1 million metric tons or 2.2 billion pounds (Staples and Chatterjee, 2002).



**Fig. 2.11** Super absorbent polymer (SAP)

### 2.9.1 Absorption capacity

SAPs are hygroscopic materials which physically entrap water via capillary forces in their macro-porous structure and through the hydration of functional groups as an absorption mechanism (Zohuriaan-Mehr and Kabiri, 2008). Two quite different mechanisms are employed to absorb fluids in absorbent products; capillarity and osmosis.

**Capillarity:** as a fluid transport mechanism, capillarity is the result of suction pressure that draws the aqueous solution into the porous structure of the polymer. The strength of the capillarity suction depends on the pore dimensions and surface energy of the absorbent substance, and the surface tension of the fluid (Staples and Chatterjee, 2002).

**Osmosis:** the net movement of fluid from hypotonic to the hypertonic solution is derived by the energy of mixing (Staples and Chatterjee, 2002). Through the expansion of the polymer chains in the solvent, the differences in the ion concentration within and around the polymer liquid lead to the swelling of the polymer grains until swelling equilibrium is reached.

Both of these phenomena occur simultaneously and lead to the swelling of the polymer. Figure 2.12 shows a single SAP particle in a dry and swollen state. As illustrated in the figure, the polymer chain is in a collapsed state before immersion, ready to imbibe the water. Within the first few seconds of immersion, the chain expands and water is drawn into the polymer grains, creating bonds with absorption units. One of the most important characteristics of SAPs is the shape preservation of their particles after swelling, which is a significant advantage for SAPs in comparison to other hydrogels. This characteristic allows these polymers to resist the pressure that will force water to be released from the crystal structure. Unlike SAPs, traditional absorbent materials (such as tissue papers and polyurethane foams) will lose most of their absorbed water when squeezed (Zohuriaan-Mehr and Kabiri, 2008).

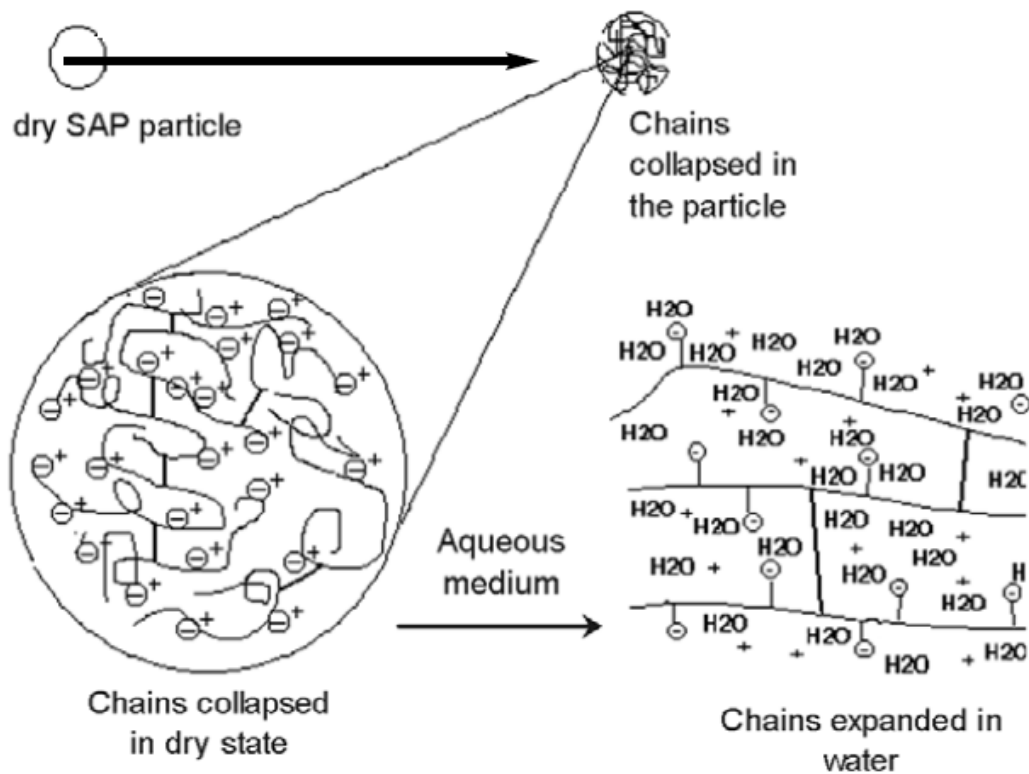

**Fig.2.12** A schematic drawing of a swelling SAP (Zohuriaan-Mehr and Kabiri, 2008).

The swelling behavior of polymers depends on two factors; one that is in the SAP and one that is in the solvent. The number of crosslinks (bonds that link one polymer chain to another) in a polymer chain will affect the expansion of the polymer so that more crosslinks result in less swelling. In other words, a network with higher crosslink density means lower equilibrium swelling capacity. The other factor is the amount of ions and organic components present in the solvent, which affect the electrical stability of the polymer chain, thus reducing the swelling capacity (Staples and Chatterjee, 2002).

Table 2.2 presents the effects of solvent characteristics on the workability of SAPs. Based on these characteristics, the behavior of SAPs in different conditions can be predicted; consequently, conditions can be set to remove the absorbed water from the swollen polymer chains. Significant increases in temperature can result in the dewatering of SAPs. The temperature in which desorption happens depends on the type of SAP and material in the chemical structure of the polymer. In addition, reduction of the pH by using strong acids as a solvent results in releasing the absorbed water.

**Table 2.2** Important factors that affect SAP workability (Zohuriaan-Mehr and Kabiri, 2008)

Factor	Absorption capacity	Absorption rate	Swell gell strength (AUL)	Soluble fraction
Increase in particle size	Non-effective	Decreasing	Increasing	Non-effective
Increase in porosity	Non-effective	Increasing	Decreasing	Non-effective
Increase in ionic strength	decreasing	Decreasing	De/increasing	Non-effective
Increase in temperature	Non-effective	Increasing	Non-effective	Non-effective
Photo/ biodegradation	increasing	Decreasing	Decreasing	Increasing
pH>7	increasing	Increasing	De/increasing	Non-effective
pH<7	decreasing	Decreasing	De/increasing	Non-effective

## 2.9.2 Types of SAPs

SAPs are categorized based on different features, but mainly based on three aspects (Zohuriaan-Mehr and Kabiri, 2008):

1. Original source
2. Presence or absence of electrical charge in the cross linked chains
3. Type of monomeric unit used in their chemical structures.

**Original source:** Based on their original sources, SAPs are often divided into two groups: synthetic and natural. The majorities of SAPs are created from fully synthetic materials or have petrochemical origin. They are produced from acrylic monomers, most frequently acrylic acid (AA), its salts and acrylamide (AM). Natural based SAPs are prepared by adding different synthetic groups into a natural substrate and categorized into two groups:

1. Hydrogels based on polysaccharides
2. Hydrogels based on polypeptides.

**Electrical charge in the cross linked chains:** If only the presence of electrically charged molecules in the cross linked chains are considered, SAPs can be divided into four groups:

1. Non-ionic.
2. Ionic (including anionic and cationic).
3. Amphoteric electrolyte (ampholytic) which contains both acidic and basic groups.
4. Zwitterionic (polybetaines) which contain both anionic and cationic groups in each structural repeating unit.

**Type of monomeric unit:** monomer types that have been used in the preparation of SAPs have a significant effect on the behavior of SAPs. Therefore, SAPs are categorized based on the type of monomeric units as follows:

1. Cross linked polyacrylates and polyacrylamides.
2. Hydrolyzed cellulose-polyacrylonitrile (PAN) or starch-PAN graft copolymers.
3. Cross linked copolymers of maleic anhydride.

### 2.9.3 SAP properties

SAPs are used in different industries and their rare and unique features provide optimal results. The following are some of the most important and determinant characteristics of SAPs (Zohuriaan-Mehr and Kabiri, 2008):

**High absorption capacity:** the most outstanding feature of SAPs is their high capacity for absorption. These materials can absorb and retain extremely large amounts of liquid relative to their own mass.

**High absorption under load (AUL):** as a result of crosslinking which provides a networked structure, these materials will not dissolve under moderate pressure. This feature has led to the widespread commercial acceptance of SAPs.

**Maximum equilibrium swelling:** At the equilibrium swelling point, the chemical potential of water inside and outside of a gel must be equal. Therefore, the elastic and mixing contribution to the chemical potential will balance each other. The swelling characteristics of polymers are highly important, especially in biomedical and remedial applications, since they influence (Ratne et al., 2004):

1. The solute diffusion coefficient of gels
2. The surface properties and surface mobility
3. The optical properties
4. The mechanical properties.

**Environmentally harmless:** nowadays, environmental issues are attached to high public attention and defined as one of the most significant and outstanding features of every project and being environmentally feasible should be proven for all projects. SAPs are highly feasible for use as they do not release any toxins and harmful chemicals into the environment during degradation. In addition, SAPs are colorless and odorless.

**Reusability:** the high cost of SAPs can be considered a disadvantage, but is negligible by focusing on the reusability of SAPs. SAPs have the ability to release and rewetted again several times with approximately equal swelling ratios.

**Photostability:** another important feature of SAPs is their resistance to changes under the influence of radiant energy and especially light. This advantage adds to the durability of their application and stability under different situations.

It is obvious that one type of SAP would not present all of these characteristics and achieving the maximum level of some of these features will lead to inefficiency of the rest. Therefore, the SAP type should be precisely chosen and based on the needs in order to achieve optimal results.

## **2.10 Summary and conclusions**

The Canadian oil sands resources or according to Time magazine “Canada's greatest buried energy treasure” has an important role in Canada’s economy and industrial development. It has been predicted that this influence will become greater in the near future. Meanwhile, the controversial environmental issues associated with this industry are overshadowing the value of the oil sands. Environmentalists, zoologists, and many others are concerned about the damage that is being incurred onto the environment in the affected areas. Therefore, MFT as one of the main byproducts of oil sand extraction is gaining significant attention. As a result, many studies have been carried out with research at both the laboratory and the field scale to try to solve the problems associated with MFT.

This chapter has provided an overview of bitumen recovery from the oil sands reserves which are operated by companies. Surface mining and in situ extraction techniques are described and the differences are discussed among the reserves that each one of these techniques is used. The HWP, as the optimal and commercially used technique to recover bitumen from sand, water and other extra material, is reviewed. MTF which are the main byproduct of HWP are discussed. These slurry tailings have very slow water release ability and permeability which result in poor consolidation rates. The HWP produces large amounts of MFT which are stored in large surface ponds. The problems and environmental concerns associated with tailings ponds have been reviewed. Different dewatering techniques that are currently in use or tested at the laboratory or the field scale have been mentioned. Moreover, the pros and cons of each technique are discussed. Much research has been implemented to improve these techniques and design new

dewatering processes; however, an optimal solution is yet to be found. Therefore, SAPs as a potential dewatering material are introduced and their characteristics have been described.

Consequently, this has inspired the author to perform a laboratory investigation to address the related issues.

## 2.11 References

- Alamgir, A., Harbottle, D., Masliyah, J. and Xu, Z. (2012) "Al-PAM assisted filtration system for abatement of mature fine tailings." *Chemical Engineering Science*, 80(1), 91-99
- Bakass M., Bellat J.P. and Bertrand G. (2006). "The adsorption of water vapor on super absorbent product at low temperatures and low mass." *Journal of Applied Polymer Science*, 100 (2), 1450-1456.
- Bakass M., Bellat J.P. and Bertrand G. (2007). "Characterization of a superabsorbent polymer." *Journal of Applied Polymer Science*, 104 (2), 782-786.
- Barbour S.L. and Wilson G.W. (1993). "Evaluation of the saturated-unsaturated groundwater conditions of a thickened tailings deposit." *Canadian Geotechnical Journal*, 30 (6), 935-946.
- Caughill D.L., Morgenstern N.R., and Scott J.D. (1993). "Geotechnics of nonsegregating oil sand tailings." *Canadian Geotechnical Journal*, 30 (5), 801-811.
- Chalaturnyk R J, Scott J. D. and Ozum B. (2002). "Management of oil sand tailings." *petroleum science and technology*, 20 (9), 1025-1046.
- Chastko, P. (2004). "Developing Alberta's oils sands: from Karl Clark to Kyoto." university of Calgary press, Calgary, Alberta, Canada, 320P
- Chatterjee P.K. and Gupta B.S. (2002). "Measurement techniques for absorbent material and products." *absorbent technology*, 389-406.
- Dawson R.F., Segó D.C., and Pollock G.W. (1999). "Freeze-thaw dewatering of oil sands fine tails." *Canadian Geotechnical Journal*, 36 (4), 578-598.
- Dzinomwa G. P. T., Wood C. J. and Hill D. J. T. (1997). "Fine coal dewatering using pH- and temperature-sensitive superabsorbent polymers." *Polymers for Advanced Technologies*, 8 (12), 767-772.
- Energy Resources Conservation Board (ERCB), Directive 074. (2009). "Tailings Performance Criteria and Requirements for Oil Sands Mining Schemes." Alberta Energy Resources Conservation Board, Calgary, Alberta, Canada.
- Fall M. , Célestin J.C., Han F.S. (2009). "Suitability of bentonite-paste tailings mixtures as engineering barrier material for mine waste containment facilities." *Mineral Engineering*, 22 (9-10), 840-848

- Fourie A., (2008), *Paste 2008: proceedings of the eleventh International Seminar on Paste and Thickened Tailings*, Australian Centre for Geomechanics, Kasane, Botswana
- Fedorak, P. M., Coy, D. L., Dudas, M.J. Simpson, M.J. Renneberg, A. J. and MacKinnon, M. D. (2003). "Microbially-mediated fugitive gas production from oil sands tailings and increased tailings densification rates." *Journal of Environ Engineering and Science*, 2(3), 199–211.
- Gosselin P., Hurdey S.E., Naeth M.A. (2010). "Environmental and health impacts of Canada's oil sand industry." The royal society of Canada (RSC), The academics of Arts, Humanities and sciences of Canada.
- Government of Alberta. (2009). "Environmental management of Alberta's oil sands." Government of Alberta, Alberta, Canada.
- Government of Alberta. "Tailings" *Government of Alberta*. June 2012. Government of Alberta. (visited 14/2/2013), <http://www.oilsands.alberta.ca/tailings.html>.
- Hocking, M.B. and Lee, G.W. (1977). "Effect of chemical agents on settling rates of sludge from effluent of hot-water extraction of Athabasca oil sands." *Fuel*, 56 (3), 325-333.
- Holowenko, F. M.; MacKinnon, M. D.; Fedorak, P. M. (2000). "Methanogens and sulfate-reducing bacteria in oil sands fine tailings waste." *Canadian Journal of Microbiology*, 46(10), 927–937.
- Jewell, R. and Fourie A. (1999). "Paste and Thickened Tailings - A Guide." 2<sup>nd</sup> edn., Australian Centre for Geomechanics.
- Johnson R.L., Bork P., Alen E.A.D., James W.H. and Koverny L. (1993), "Oil sands sludge dewatering." Alberta conservation and reclamation council, Alberta, Canada.
- Kasperski, K.L. (1992). "A review of properties and treatment of oil sands tailings." *AOSTRA Journal of Research*, 8, 11-53.
- Mikula R.J., Kasperski K.L, Burns R.D, and MacKinnon M D. (1996). "Nature and fate of oil sands fine tailings." *American Chemical Society*, 251 (14), 677-723.
- NEB. (2000). "Canada's oil sands: A supply and market outlook to 2015." National Energy Board, Alberta, Canada.
- NEB. (2004). "Canada's oil sands: Opportunities and challenges to 2015: an update." National Energy Board, Alberta, Canada.

- NEB. (2006). "Canada's oil sands: Opportunities and challenges to 2015: an update." National Energy Board, Alberta, Canada.
- OSRIN Report. (2010). "Oil Sands Tailings Technology Review." BGC Engineering Inc., Oil sands research and information network, University of Alberta, School of Energy and the Environment, Edmonton, Alberta, Canada.
- Peer, F. and Venter, T. (2003). "Dewatering of coal fines using a super absorbent polymer." The Journal of the South African Institute of Mining and Metallurgy, 103 (6) 403-410.
- Pollock, G. W. (1988). "large strain consolidation of oil sands tailings sludge." M.A.Sc. thesis, University of Alberta, Edmonton, AB.
- Powter C.B., Biggar K.W., Silva M.J., McKenna G.T. and Scordo E.B. (2011). "Review of oil sands tailings technology options." In Tailings and Mine Waste '10, Taylor & Francis Group, London.
- Proskin S., Segó D., Alostaz M. (2010). Freeze-thaw and consolidation tests on Suncor mature fine tailings (MFT), Cold Regions Science and Technology, 63 (3), 110-120.
- Punmia B.C., Jain A. K and Jain A. Kr. (2005). "Soil Mechanics and Foundations: soil structure and clay mineralogy." 16th edn, Laxmi publication, New Delh, India.
- Ratne B.D., Hoffman A.S., Schoen F.J., Lemons J.E. (2004). "Biomaterials science: an introduction to materials in medicine." Academic press, 848 P
- Rogers, V.V., Liber, K. and MacKinnon, M. D. (2002). "Isolation and characterization of naphthenic acids from Athabasca oil sands tailings pond water." Journal of chemosphere, 48 (5), 519-527.
- Sadeghi M. and Hosseinzadeh H. (2008). "Synthesis and Swelling Behavior of Starch-Poly (Sodium Acrylate-co-Acrylamide) Superabsorbent Hydrogel." Turk J Chem., 32 (3), 375-388.
- Silva M.J., Biggar K.W. and Jacobsz S.W. (1999). "Plant Dewatering and strengthening of tailing: Laboratory and computer simulation." In Tailing and waste management, A.A Balkema, Netherland, 315-322.
- ST98-2004. (2004) Alberta's Energy Reserves 2003 and Supply/Demand Outlook 2004-2013." Energy Resources Conservation Board (ERCB), Calgary, Alberta.
- ST98-2011. (2011). "Alberta's Energy Reserves 2010 and Supply/Demand Outlook 2011-2020." Energy Resources Conservation Board (ERCB), Calgary, Alberta.

- ST98-2012. (2012). "Alberta's Energy Reserves 2011 and Supply/Demand Outlook 2012–2021."  
Energy Resources Conservation Board (ERCB), Calgary, Alberta, Canada.
- Staples T. L., Chatterjee P. K. (2002). "Synthetic super absorbents." In *Absorbent Technology*,  
383-318.
- WWF report. (2010). "Tailings, A lasting oil sands legacy." WWF-Canada, Canada.
- Xu, Y., Dabros T. and Kan J., (2008). "Filterability of oil sands tailings." *Process Safety and  
Environmental Protection*, 86(4), 268-276.
- Yeh, S., Jordaan, S., Brandt, A., Turetsky, M., Spatari, S. and Keith, D. (2010). "Land use  
greenhouse gas emissions from conventional oil production and oil sands." *Journal of  
environmental science and technology*, 44(22), 8766-8772.
- Zohuriaan-Mehr M.J and Kabiri K. (2008). "Superabsorbent polymer materials: A Review."  
*Iranian Polymer Journal*, 17 (6), 451-477.

## Chapter 3

### Technical paper I

#### **SAP based rapid dewatering of oil sands mature fine tailings**

**Aida Farkish, Mamadou Fall**

*University of Ottawa, Department of Civil Engineering, 161 Louis Pasteur, Ottawa, Ontario, Canada K1N 6N5*

**Abstract** - The Canadian oil sands resources presents one of the world's most vast hydrocarbon deposits. The processing of oil sands to extract bitumen generates large volumes of mature fine tailings (MFT). The large volume, poor consolidation and water release ability of MFT have been causing significant economic and environmental concerns. Therefore, significant research efforts have been devoted to finding methods for the dewatering and densification of MFT. In the present paper, a novel approach which consists of the rapid dewatering of MFT by using a super absorbent polymer (SAP) to produce dense MFT is proposed. A comprehensive laboratory investigation on the shear strength testing of MFT specimens dewatered by SAP by using a vane shear apparatus is conducted. Furthermore, the effect of freeze/thaw cycles on the undrained shear strength of the dewatered MFT is studied. Finally, the ability of recycled SAP to dewater and densify MFT is also assessed. Promising results have been obtained. The results indicate that SAP has the ability to significantly dewater, densify and increase the undrained shear strength of MFT. Furthermore, when subjected to freeze/thaw cycles, the MFT dewatered with SAP shows an additional increase in strength and solid content. It is also found that it is possible to regenerate the polymer (still within sachets) through light thermal drying, and the regenerated SAP can still significantly dewater and thus increase the shear strength and solid content of MFT. Therefore, SAP regeneration and the use of regenerated SAP to dewater MFT in a cost-effective way should be assessed in further studies.

**Keywords:** Oil sand, Tailings; Mature Fine Tailing, Super Absorbent Polymer (SAP), Freeze/thaw, Dewatering, strength

### 3.1 Introduction

Oil sands reservoirs as an unconventional form of petroleum are found in about 70 countries around the world, but the largest and primary oil sands reservoirs are located in eight countries: Albania, Canada, Madagascar, Romania, Russia, Trinidad, the USA and Venezuela. Over 95% of the known in-place oil volumes occur in Canada, particularly in northern Alberta. The northern Alberta oil sands resources comprise one of the world's vast hydrocarbon deposits, which extend over 77,000 km<sup>2</sup>, and are distributed in three principle areas: Athabasca, Cold Lake and Peace River (Chalaturnyk et al. 2002).

Oil sands exploration includes both mining ("conventional" methods) and in-situ ("non-conventional") production methods. Due to contaminants and high viscosity, the first problem in exploiting bitumen, which is found in the oil sands, is bringing it to the surface. Various open mining techniques are used to extract oil, and in each of these methods, the bitumen that is pumped to the surface is concomitant with sand, clay minerals, water and air that result in a mixture called a bitumen-rich froth (Canada's Oil Sands Report, 2000). Therefore, bitumen needs to be refined. To extract bitumen, the Clark hot water process (CHWP) (based on the pioneering work of Dr. Karl Clark; Clark 1939; Clark and Pasternack 1932) is commonly used. By using this method, roughly 90% of the bitumen can be recovered from sand. However, this oil sands extraction process generates huge amounts of tailings. It has been estimated that about two tons of oil sands are required to produce one barrel of refined oil (Chalaturnyk et al. 2002). In the current commercial plants, the freshly produced tailings from the extraction operation are typically directed to tailings ponds where the coarse fraction of solids (coarse silt and sand) quickly segregates from the fine fraction and settles. On the other hand, the fine particles (predominantly silt and clay) settle very slowly. After 2–3 years of settling, these fine solids attain a particle concentration of about 30–40 wt% and form a suspension called mature fine tailings (MFT) with virtually no further consolidation. The MFT is the most controversial environmental issue associated with oil sand exploration.

The very large scale of commercial oil sands operations results in the accumulation of a large quantity of MFT. MFT have poor consolidation and water release characteristics. Thus, due to their large depth and very low permeability, the densification under self-weight is very slow and it is estimated that it will take several decades to become trafficable under natural conditions

(BGS Engineering Inc. 2010). It has been predicted that if no change is made in oil sands tailings management or no other dewatering methods are used, the accumulation of tailings which was 400 million cubic meters in 2002 would increase to over one billion cubic meters by 2020 (Chalaturnyk et al. 2002). The media and environmental organizations often emphasize the fact that the oil sands tailings ponds are so large that they can be seen on satellite photos and can easily be found on Google Earth (Powter et al. 2011). This large volume of MFT is detrimental to the sustainability of the oil sands industry. The continuing accumulation of MFT is causing huge economic and environmental concerns. Therefore, storage and disposal of the vast amounts of MFT remain one of the major problems and technological challenges associated with the current oil sands mining and processing technology.

Due to the facts mentioned above, the oil sands industry has expended considerable effort in research on the development of technologies for dewatering, densification and speeding up the consolidation of MFT. Moreover, the research on a viable MFT dewatering and management technology has been intensified since the oil sands industry is required to meet the objectives of Directive 074 from the Energy Resources Conservation Board (ERCB 2009). The key requirement of Directive 074 is that oil sands operators deposit a significant portion of their annual production of fine tailings in designated disposal areas (DDAS). The DDAS must be formed in a manner that ensures trafficable deposits. The performance criteria are based on the strength of the deposit (Houlihan et al. 2010). The following criteria were set by the ERCB: (i) a minimum undrained shear strength of 5 kPa must be reached for the tailings deposited in the previous year; (ii) the tailings material deposited in the previous year which does not meet the 5 kPa requirement must be removed or remediated; and (iii) the deposit must be ready for reclamation within five years after active tailings deposition has stopped. The deposit will have the strength, stability, and structure required to create a trafficable surface. The minimum undrained shear strength of the surface should be at least 10 kPa (Houlihan et al. 2010).

Over the years, many dewatering and/densification technologies or methods have been developed and used or tried to dewater and improve the settling characteristics of these fine tailings. These technologies have been divided into five major types: natural processing, mechanical processing, chemical or biological processing, mixture disposal and permanent storage (BGS Engineering Inc. 2010). One of the most important chemical amendment technologies for the dewatering and the densification of MFT is the addition of polymers as

flocculants to the MFT. Although various flocculation mechanisms are possible, the most important is flocculation by bridging. The addition of these flocculating polymers can enhance the settling rate of the tailings and promote the recovery of water and its recirculation in the oil sands process (Masliyah 2007). To date, polymeric flocculants have been widely used in the oil sands industry, alone or in combination with electrolyte coagulants (e.g., composite tailings CT, tailing reduction operation, TRO). For example, during the TRO process MFT is mixed with a polymer flocculent (anionic polyacrylamide) and deposited in thin layers on slightly sloped areas. As the fines in the MFT consolidate because of the action of the polymer, water in the mixture is released and runs off to be recycled in the production process. More water evaporates as the MFT deposit dries within the deposit (WFF 2010).

However, many of these technologies have been rejected for lack of technical or economic feasibility. Yet technologies that were previously considered as uneconomical may now be regarded as a viable alternative given the requirements of Directive 074 and changing economic conditions. Despite this intense research effort, there is still no optimal and unique technology to treat MFT. Therefore, significant research effort is now devoted to finding alternative methods for MFT dewatering/densification and developing schemes which use more than one type of fine tailings management technology and combining them into a disposal package (Powter et al. 2011).

In the present paper, a novel approach which consists of dewatering MFT by using a super absorbent polymer (SAP) (different than the flocculating polymers mentioned above) to produce dense MFT is proposed. The approach proposed does not require the addition of coarse particles to the mature fine tailings to produce composite slurry (Laros and Baczek, 2012), as well as it can allow the dewatering of the MFT without directly mixing the MFT with the SAP. A comprehensive laboratory investigation on the shear strength testing of MFT specimens dewatered by SAP by using a vane shear apparatus for two types of MFT specimens is conducted. Furthermore, the effect of freeze/thaw cycles on the undrained shear strength of the SAP dewatered MFT is studied. Finally, the ability of recycled SAP to dewater and densify the MFT is also assessed.

## **3.2. Experimental program**

### **3.2.1. Material**

#### **Mature fine tailings (MFT)**

In this study, MFT sampled from an oil sands tailings pond located in northern Alberta are used. Various laboratory tests were conducted to determine the physical, mineralogical and chemical characteristics of the sampled tailings. Figure 3.1 shows the grain size distribution of the MFT obtained through a wet laser diffraction analysis. The tested MFT contain about 19% clay, 77% silt and 4% sand. The results of the Atterberg limits determination (ASTM D4318 – 10) showed that the liquid limit (LL) and the plastic limit (PL) of the MFT are equal to 51.2 and 37.2, respectively; this comprises a plasticity index of 14. The activity of the MFT was determined to be equal to 0.77, i.e., the MFT has normal activity as a result of a high concentration of quartz (Table 3.1). The x-ray diffraction analysis results of the MFT sample indicated that the mineral content consists of 33.6% quartz, 31.3% kaolinite and 21.8% muscovite (Table 1). Various studies have determined that the bitumen content of MFT varies from 2% to 30%, but is probably more typically in the range of 2% to 10% by dry weight.

The chemical composition of the water in the MFT shows some organic components that are believed to be released from the bitumen. As Table 3.2 illustrates, the chemical composition (determined by inductively coupled plasma atomic emission spectroscopy (ICP-AES) of the MFT pore water shows a high concentration of dissolved cations, such as magnesium, calcium and more importantly, sodium, in the MFT pore water, which was added during the extraction process. The pH of the pore water was determined to be 7.9, which is in an optimal range for clay particles to keep their charge and remain in the suspension (Hocking et al., 1977).

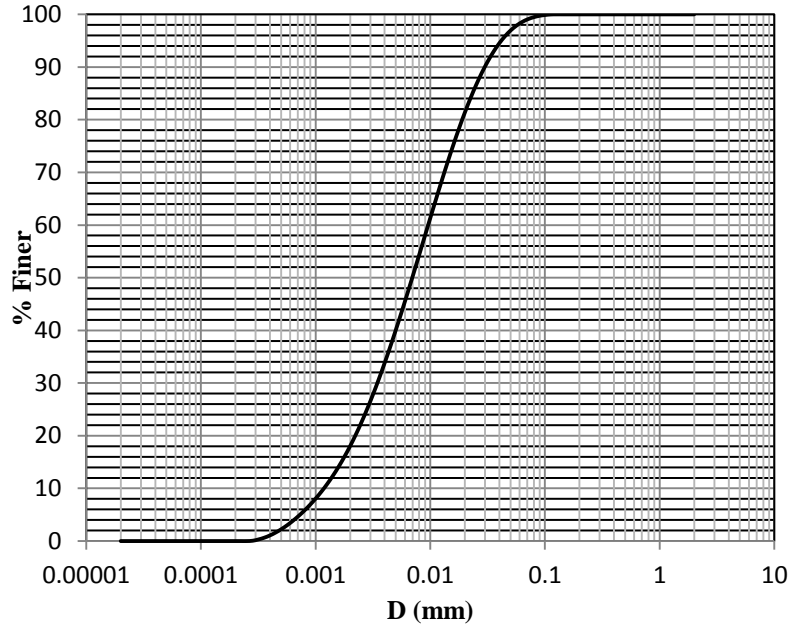

**Fig.3.1** MFT grain size distribution

**Table 3.1** MFT mineralogy

<b>Mineral</b>	<b>Percentage (wt%)</b>	<b>Formula</b>
<b>Quartz</b>	33.6	SiO <sub>2</sub>
<b>Kaolinite</b>	31.3	Al <sub>2</sub> (Si <sub>2</sub> O <sub>5</sub> )(OH) <sub>4</sub>
<b>Muscovite</b>	21.8	KAl <sub>3</sub> Si <sub>3</sub> O <sub>10</sub> (OH) <sub>2</sub>
<b>Siderite</b>	4.5	FeCO <sub>3</sub>
<b>Orthoclase</b>	4.0	KAlSi <sub>3</sub> O <sub>8</sub>
<b>Brookside</b>	2.3	TiO <sub>2</sub>
<b>Magnetite</b>	2.1	Fe <sub>3</sub> O <sub>4</sub>
<b>Calcite</b>	0.2	CaCO <sub>3</sub>

**Table 3. 2** Pore water chemistry of the MFT used

<b>Metal</b>	<b>Conc. µg/L</b>	<b>Metal</b>	<b>Conc. µg/L</b>	<b>Metal</b>	<b>Conc. µg/L</b>
<b>Na</b>	960000	<b>Si</b>	8700	<b>Sr</b>	540
<b>K</b>	19000	<b>Fe</b>	5900	<b>Ba</b>	250
<b>Mg</b>	13000	<b>B</b>	3500	<b>Li</b>	250
<b>Ca</b>	8000	<b>Al</b>	2300	<b>P</b>	210

**Conc:** concentration

## **Super absorbent polymers (SAPs)**

SAPs are hydrophilic gels that contain a network of polymer chains capable of absorbing and retaining extremely large amounts of water relative to their own mass (Staples 2002). These products are able to absorb up to 1000 times their weight of water through physical absorption by using capillarity, osmosis mechanisms, and hydration of functional groups (Zohuriaan-Mehr et al. 2008). Strong osmotic pressure derives the liquid into a polymeric chain and spreads the polymer network into the liquid, which exhibit the swelling ability of the SAPs. Swelling is constrained at the swelling equilibrium point where any incremental pressure will cause the fluid to exude the polymer chains. The SAP hydrogels exhibit high sensitivity to pH, thus swelling changes may be observed in a wide range of pHs, from 1-13. Table 3.3 shows the effect of different factors on the behaviour of SAPs (Zohuriaan-Mehr et al. 2008).

The SAP used in this work (called “Aqua Sorb” by the manufacturer) is a granular cross-linked polyacrylate advanced SAP that rapidly absorbs and retains large volumes of aqueous solutions. The size of the SAP particle ranges from ¼ inch to 45 microns in diameter (ARK, 2003). This product is ideally suited for absorption and solidification of different types of waste waters, with an absorption capacity of 250-300 (gr liquid/ gr SAP) in deionized water as provided by the manufacturer (ARK Enterprises, Inc). This absorption capacity was also confirmed by the SAP absorption tests conducted in the present study (Figure 3.2).

It is well known that the chemical composition or ionic strength of water has a significant effect on the water absorption capacity and rate of SAP (Table 3.3). Hence, the effect of four types of water (distilled; tap; tap water – MFT water mixture (50/50), i.e. the mixture is made of 50% tap water and 50% MFT water; and MFT water) on the absorption capacity and rate of the SAP used in the present study was investigated by using the tea bag method (Sadeghi and Hosseinzadeh 2008). The obtained results are presented in Figure 3.2. Figure 3.2 shows a significant reduction in the SAP absorbing capacity for the MFT water in comparison with distilled and tap water. The presence of organic compounds, a high erythrocyte sedimentation rate (ESR) of the tailings water, and fine particle size of the tailings, affect the absorption mechanisms of the polymer chains. However, it should be emphasized that despite the observed drop in the SAP absorption capacity for the MFT water and the MFT/tap water mixture, the SAP absorption capacity still remains very high. From Figure 3.2, it can be observed that 1 g of SAP

can absorb 107 g of MFT water and 138 g of MFT/tap water mixture (50/50). This indicates that the SAP could lead to the significant dewatering of MFT.

**Table 3.3** Effects of different physical and environmental factors on the behaviour of SAP (adapted from Zohuriaan-Mehr et al. 2008)

Factor	Absorption Capacity	Absorption rate
Increase in particle size	No effects	Decreasing
Increase in porosity	No effects	Increasing
Increase in ionic strength of medium	Decreasing	Decreasing
Increase in temperature of medium	No effects	Increasing
pH > 7	Increasing	Increasing
pH < 7	Decreasing	Decreasing

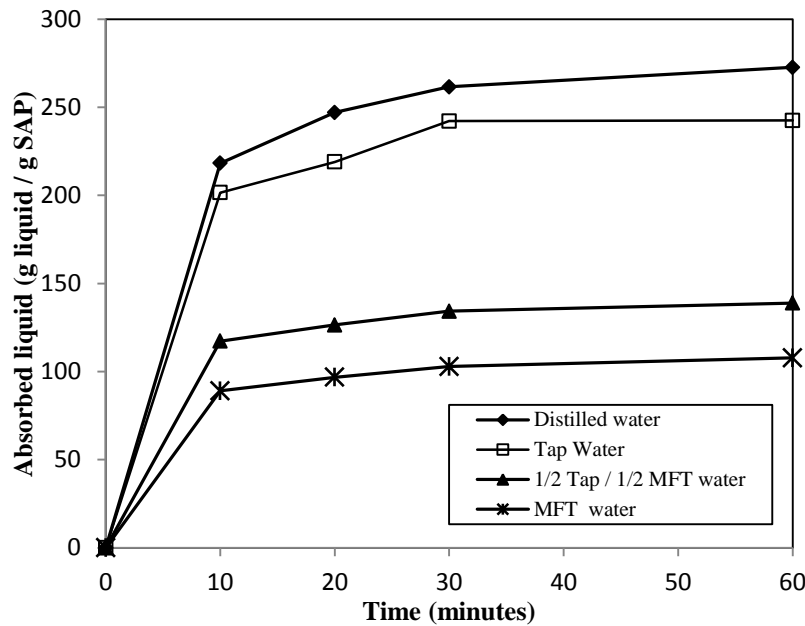

**Fig. 3.2** Absorption capacity of the SAP

### 3.2.2 SAP dewatering methods, specimen preparation and mix proportioning

Two types of SAP based dewatering methods are used in this investigation. The first method, called the direct method in this study, consists of directly mixing a known weight of SAP with a known weight of MFT in a large container until a homogenous mixture is obtained.

The mixing was done manually by using a spatula. The mixing time was approximately 10 min. Various SAP proportions were used to prepare the mixes: 0%, 0.5%, 1% and 3% (the percentage of SAP is by wet mass of MFT). The containers of the SAP-MFT mixtures were then sealed with plastic foil to prevent evaporation. At specific time intervals, the SAP-MFT samples were taken for vane shear testing. The sampling was very carefully done at low pressures by applying a stainless steel core sampler with tubes and a cutting head to obtain an undisturbed sample. The undisturbed cylindrical samples were taken at five different time intervals (1, 8, 24, 72 and 168 hours) and subjected to vane shear testing.

The second method, called the indirect method in the present study, consists of placing sachets (16 × 10 cm) filled with various amounts of SAP (SAP sachets) into containers (40 x 20 cm rectangular containers) that contain MFT slurries, and then the containers were covered with plastic foil to avoid evaporation. These sachets are made of cloth (textile) which would allow the SAP to absorb water from the MFT without direct contact with the tailings. The porosity of the sachet cloth is 47%, which was determined by water evaporation method. The use of SAP in sachets enables the easy separation of the SAP from the MFT, and then the recycling (reuse) of the SAP (see section on SAP regeneration). Sachets with the following dosages of SAP were used: 0%, 0.5%, 1% and 3% in weight. Each sachet contained 5 g of SAP and weighed 10 g (including the cloth) before the mixing with the MFT. The MFT slurries were mixed with the SAP sachets by using a B20F mixer for 10 minutes every day during the first four days, and then left to rest for the next three days. The trial tests performed have shown that this approach (10 min. mixing/day for four days) provides the highest solid content and requires the lowest energy consumption. The mixing of the MFT slurries with the SAP enables to increase the surface contact between the MFT and the SAP sachets (e.g., Dzinomwa et al. 1997). After seven days, the SAP sachets were removed and the first vane shear test was conducted. The removal was done by using a spatula to take away the thin layer of MFT, which was accumulated around the SAP sachets.

## 3.3 Testing and procedures

### 3.3.1 Freeze–thaw cycles

Surface tailings disposal facilities in a cold area, northern Alberta, can be subjected to a series of freeze–thaw cycles that may significantly contribute to the dewatering of MFT. It is therefore, important to determine the impact of the combination of SAP based dewatering methods and freeze–thaw cycles on the dewatering and densification of MFT. The combination of both types of dewatering technologies could result in a significant increase of the strength and densification of the treated MFT as well as reduction in the cost of MFT dewatering.

To evaluate the performance of SAP-MFT subjected to freeze/thaw cycles, four different mixtures of MFT with 0%, 0.5%, 1% and 3% SAP were prepared for both types of SAP dewatering methods (direct and indirect). The initial solid content of the MFT was measured to be 38% by using oven drying. For the direct method, SAP-MFT mixture samples were cured in 40 x 20 cm rectangular containers for different curing times of 1, 3 and 7 days. Each container retained a SAP-MFT layer of 6 kg that was 20 cm in depth. During the freeze/thaw application, the method introduced by Johnson et al. (1993) was followed. This method is fully described in Johnson et al (1993). One dimensional freeze/thaw was used because it represents conditions closer to the field freezing situations (Othman et al, 1994). For the indirect method, a certain number of SAP-sachets (0.5%, 1%, 3%) were added to the MFT in 40 x 20 cm rectangular containers. Then, as previously explained for the indirect method, MFT slurries were mixed with the SAP-sachets by using a mixer for 10 minutes every day during the first four days, and then left to rest for the next three days. After seven days, the SAP-sachets were removed and the MFT samples were placed into the freezer.

For both methods, the samples were frozen in a freezer at -24°C for 24 hours and thawing was carried out at room temperature (23°C) until all of the frozen water was melted (approximately 24 hours). A simple draining method was implemented by using a 1 cm layer of sand at the bottom of the container that drained into a channel in the middle. For the removal of the accumulated water on the surface, a 2% stable slope was formed by using Eq.3.1, and metal shims were placed under one end of the container as shown in Figure 3.3.

$$\text{Eq. (3.1) Slope} = \frac{(Hw_1 - Hw_2) - (Ht_1 - Ht_2)}{30} \times 100$$

Where  $H_w$  is the distance of the led tip of the container from the released water and  $H_t$  is the distance of the tip of the container from the tailings.

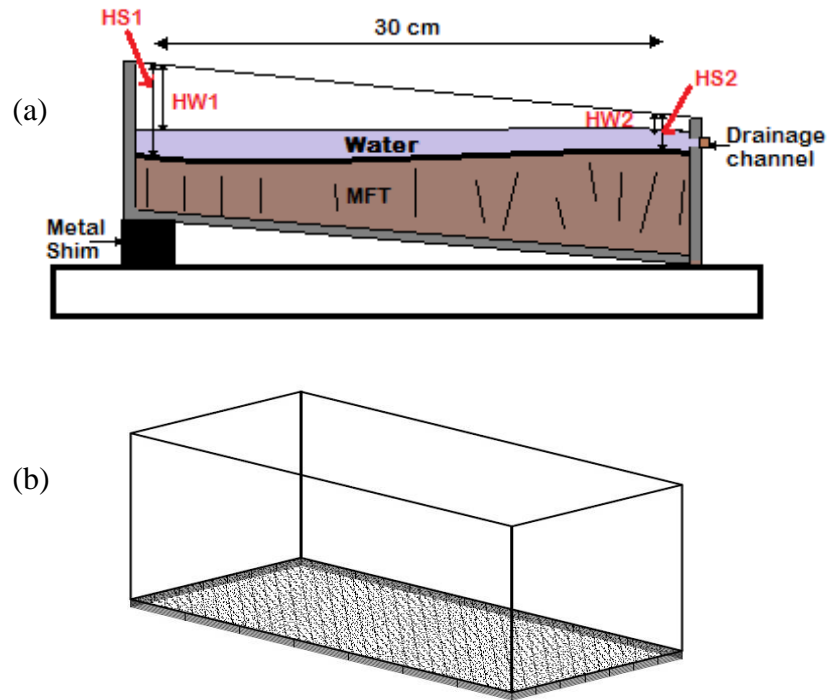

**Fig. 3.3a** Front view of the slope table. **Fig. 3.3.b** drainage system at the bottom of the container

The surface of the frozen MFT showed a network of cracks that were filled with ice crystals which extended throughout the entire tailings. During the thawing process, cracks created by ice crystals provide sufficient canals for the water to reach the surface or drain from the bottom of the container. The water released from the tailings during the thawing process was clear with some streaks of bitumen.

The SAP-MFT was subjected to two freeze/thaw cycles and the thickened mixture was sampled (cylindrical samples) for the purpose of vane shear testing. For each combination of SAP percentage and curing time, two samples were taken to exhibit the repeatability of the results.

### **3.3.2 Regeneration of SAP**

Regeneration of SAP is an excellent way to reduce the cost of dewatering and prevent the waste of reusable polymer, which will also conserve the environment. The ability of SAP to be regenerated by various means also makes this option attractive. In the present study, two techniques of regeneration are investigated, which include pH control and temperature control. The SAP regeneration procedure adopted by Dzinomwa et.al. (1997) was followed.

#### **pH- controlled regeneration**

For pH-controlled regeneration, the pH of the swollen polymer is reduced to 1.0 by adding hydrochloric acid (50% wt). The mass of the acid added to the SAP is 0.01 times of the absorbed water of the polymer. Upon the addition of acid, the SAP starts to release the absorbed water and after approximately 1 hour, an equilibrium level between the released and residual water is reached. The polymer is separated from the acid and the released water by sieving, and washed with distilled water later to rinse off the remaining acid. In order to cancel the effect of acid and neutralize the SAP, the polymer is washed with sodium hydroxide. As the last step, the SAP is oven dried to remove any residual water and by repeating this process, the change in the absorption capacity can be determined.

#### **Temperature-controlled regeneration**

In temperature-controlled regeneration, the swollen polymer is placed into an oven at a temperature of 65°C for 36 hours to release the absorbed water. By recording the weight loss of the SAP through time, the actual time period required for desorption is determined, and by repeating the process, the reduction of the absorption capacity of the polymer is derived.

Figure 3.4 shows the results of a primary test conducted to determine the change in the SAP absorption capacity for MFT water and tap water during five cycles of regeneration for both the pH and temperature controlled regeneration methods. As illustrated in Figure 3.4, the SAP regenerated through the temperature controlled method holds higher absorption ability, and absorbs more liquid in the next cycle. In addition, it was observed that the SAP immersed into acid was not able to perform the granular shape after the procedure and would remain as one aggregate. Also, the pH controlled regenerated SAP could not regain the solid phase after oven drying and remained in the jelly phase, due to the destruction of the polymer structure by the

strong acid. These problems were not resolved by increasing the water content of the acid solution or reduction in immersion time. Therefore, temperature controlled regeneration is found to be more efficient and applicable and was used as the main recycling method throughout the study.

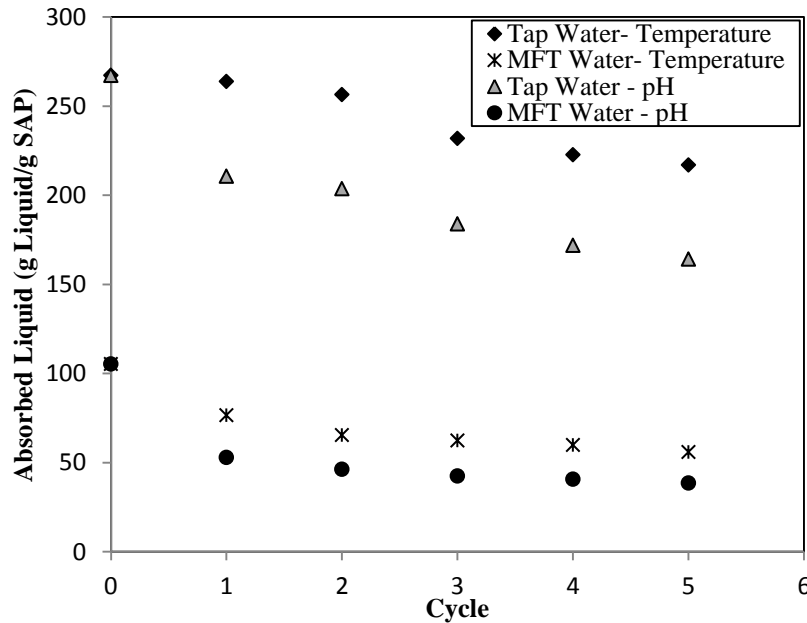

Fig. 3.4 Change in the absorption capacity of the SAP by performing different methods of regeneration

### 3.3.3. Vane shear tests

The vane shear apparatus that was used constitutes of miniature vanes that can be used to shear a predetermined surface along a cylindrical surface to determine the undrained shear strength of saturated fine-grained clayey soils. Vane shear testing was carried out in accordance with ASTM D4648. The vane shear tests were performed in depth of 10 cm from the top of the sample. A four-blade vane with a vane constant ( $K_V$ ) of  $0.000942 \text{ m}^3$  was inserted into an undisturbed tube specimen. The vane constant is a function of the height and width of the vane's blade and was derived by using the following equation:

$$\text{Eq. (3.2)} \quad K_V = \frac{\pi D^2 H}{2 \times 10^6} \left[ 1 + \frac{D}{3H} \right]$$

Where  $D$  is the measured diameter of the vane (mm) and  $H$  is the measured height of the vane (mm).

The vane rotates at a constant rate to determine the torque required to cause a cylindrical surface to be sheared by the vane and the torque is measured by a calibrated spring directly attached to the vane. Spring number one with a spring constant ( $K_s$ ) of 0.0327 was used which produced a repeatable linear relationship between spring deflection (degrees) and applied torque. In the end, the shear strength of the MFT specimen was derived by using the following equations:

$$\text{Eq. (3.3) } T = \Delta R_s \times K_s$$

$$\text{Eq. (3.4) } \tau = \frac{T}{K_v}$$

Where  $T$  is the spring torque (Nm),  $\Delta R_s$  is the actual spring rotation (degree) and  $\tau$  is the shear strength of the specimen (Pa).

It should be emphasized that the remolded zones around a vane blade resulting from insertion is commonly assumed to be small and have slight or no influence on the stress-strain properties of the soil being tested (ASTM D4648/D4648M – 10). In fact, the volume of soil disturbed by the insertion of the vane blade into the assumed cylindrical volume of soil being tested may be significant. Therefore, as recommended by ASTM D4648/D4648M – 10, the vane should displace no more than 15% of the soil being tested which is defined by the vane area ratio (ASTM D4648; Flaate 1966).

Vane shear testing was performed on MFT specimens dewatered through the direct and indirect methods, respectively, as well as on those subjected to freeze/thaw cycles and dewatered with regenerated SAP. The diameter of the MFT specimens was sufficient to allow clearance of at least two blade diameters between all points on the circumference of the shearing surface and the outer edge of the specimen as recommended by ASTM D4648/D4648M.

For the direct method, vane shear testing was conducted on undisturbed cylindrical specimens sampled at five different time intervals (1, 8, 24, 72 and 168 hours). For each combination of SAP percentage and curing time, two samples were tested to ensure the repeatability of the results.

For the indirect method, two series of vane shear tests were performed. The first series of tests were conducted on specimens aged 7 days (MFT slurries were mixed with the SAP sachets by using a mixer for 10 minutes every day during the four first days, and then left to rest for the next three days; after 7 days, the SAP sachets were removed). The second series of tests were performed on specimens aged 14 days; the SAP sachets were removed after 4 days followed by a resting period of 10 days (in a sealed container). Again, each test was repeated at least twice.

For the samples subjected to freeze/thaw, vane shear testing was performed after each cycle for both mixing methods.

The vane shear testing conducted on the MFT treated with regenerated SAP was performed on specimens aged 14 days. The sachets were removed after 4 days followed by a resting period of 10 days (in a sealed container) and each test was repeated at least twice to obtain accurate results.

### **3.3 Results and discussion**

#### **3.3.1 Vane shear testing on SAP-MFT (Direct method)**

Shear strength versus curing time for the specimens is plotted in Figure 3.5 along with the solid content of the samples. The slope of the graphs shows the absorption rate of the SAP which is the highest during the first 24 hours and then gradually decreases. During this time, the swollen polymer grains became visible in the mixture as the result of the absorbed water and the mixture was visibly dryer. Polymer grains, by developing a strong osmotic pressure, absorbed the water trapped among the fine particles and retained the water in the polymer chains that spread throughout the MFT (Zohuriaan-Mehr et al. 2008). With a higher portion of SAP, that is, 3%, the sample exhibited higher strength and a solid content. After 24 hours of curing the MFT with 3% SAP, the sample demonstrated strength close to 5000 Pa, which is the strength required by the ERCB (2009). From Fig.3.5 (a), it can be also seen that the strength of the MFT-SAP nearly stabilizes after 72 hours and its increase throughout the following days is negligible. At this point, the SAP reaches an equilibrium point, which is achieved at the highest absorption capacity. The slight increase in the shear strength after this point can be described by the increase in the structural strength of the MFT as a result of particle settlement and consolidation under its

weight. The final shear strengths of 0.5%, 1%, and 3% SAP-MFT samples after 7 days of curing were determined to be 1.2, 2.5, and 5.2 kPa, respectively.

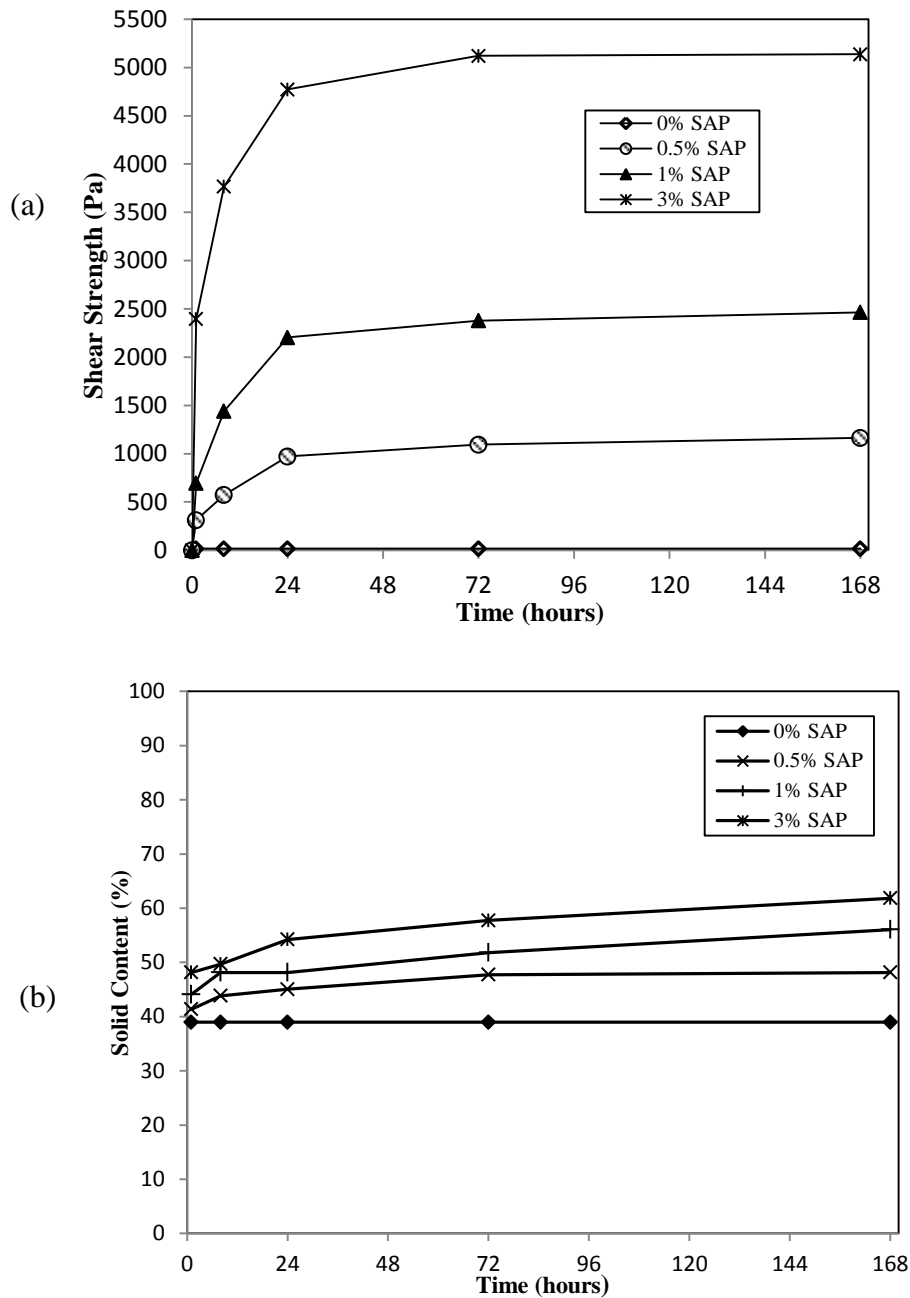

**Fig. 3.5a** Vane shear strength of MFT directly mixed with SAP versus time **Fig. 3.5b** Solid content of MFT directly mixed with SAP vs. time

The evolution of the solid content of the specimens is shown in Figure 3.5b, which indicates a similar pattern as the shear strength. In order to determine the solid content of the

mixture, the samples were taken from those with no SAP to obtain more accurate data. The sample with 3% SAP obtains the maximum solid content after a week of curing. The solid content of the untreated MFT is 39% which later improves to over 60%.

The results of the shear strength testing demonstrate the ability of the SAP to significantly increase the speed of MFT solidification and shear strength. As shown in Figure 3.6, the tailings with the addition of 1% (Figure 3.6b) and 3% SAP (Figure 3.6c) are dry enough to present a structure and show a higher shear strength compared to the untreated MFT (Figure 3.6a).



**Fig. 3.6** Effect of changes made with direct method on the MFT with the addition of different amounts of SAP: a) 0%; b)1%; c) 3%

By using this method, high undrained shear strength was achieved after a few days, which is significantly encouraging compared to the one year required in the ERCB (2009). Another

interesting aspect of the obtained results is the fact that the effect of evaporation was not taken into account for the curing of the MFT and all the samples were sealed. Meanwhile, evaporation from the surface of the MFT in the tailings ponds can highly increase their strength and solid content. Thus, it should be expected that when exposed to evaporation in the field, SAP-MFT would show a significant additional increase in strength.

### 3.3.2 Shear strength of MFT dewatered with SAP-sachets (indirect method)

Figure 3.7a shows the results of vane shear testing performed on MFT dewatered with SAP sachets. The initial shear strength of the MFT samples that were mixed for 4 days with the polymer sachets and allowed to rest for the next 3 days is significantly different from that of the samples that were allowed to rest for another 7 days after the separating of the polymer sachets. Although the samples taken from the 3% SAP mixture presented a high strength of 9 kPa after the first 7 days, samples with 1% and 0.5% SAP endured lower stresses for the first week of amendment. As shown in Figure 3.7a, the samples that are allowed to rest for a week (i.e., 14 day aged samples) have higher strength because of the improved structure and arrangement. The tests for the 3% SAP samples show a 4 kPa increase in strength, while the 0.5% and 1% SAP samples improved by 1 and 2 kPa, respectively.

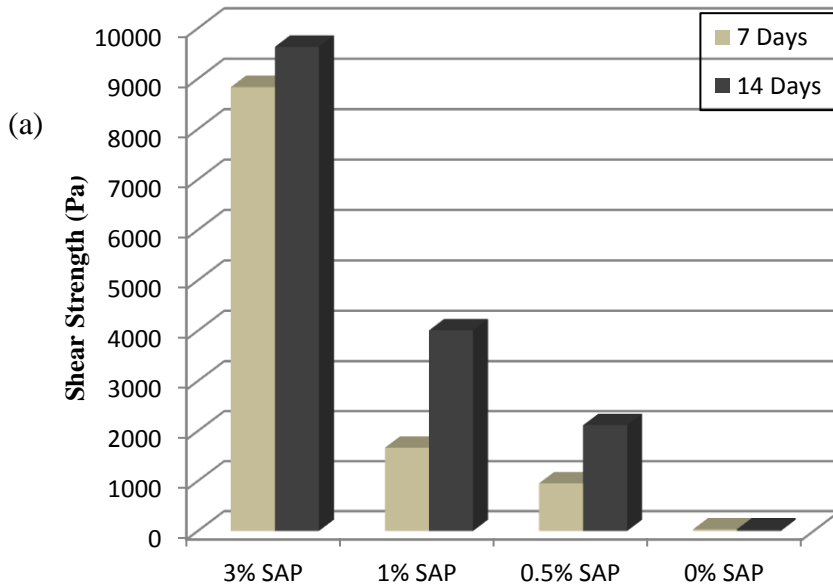

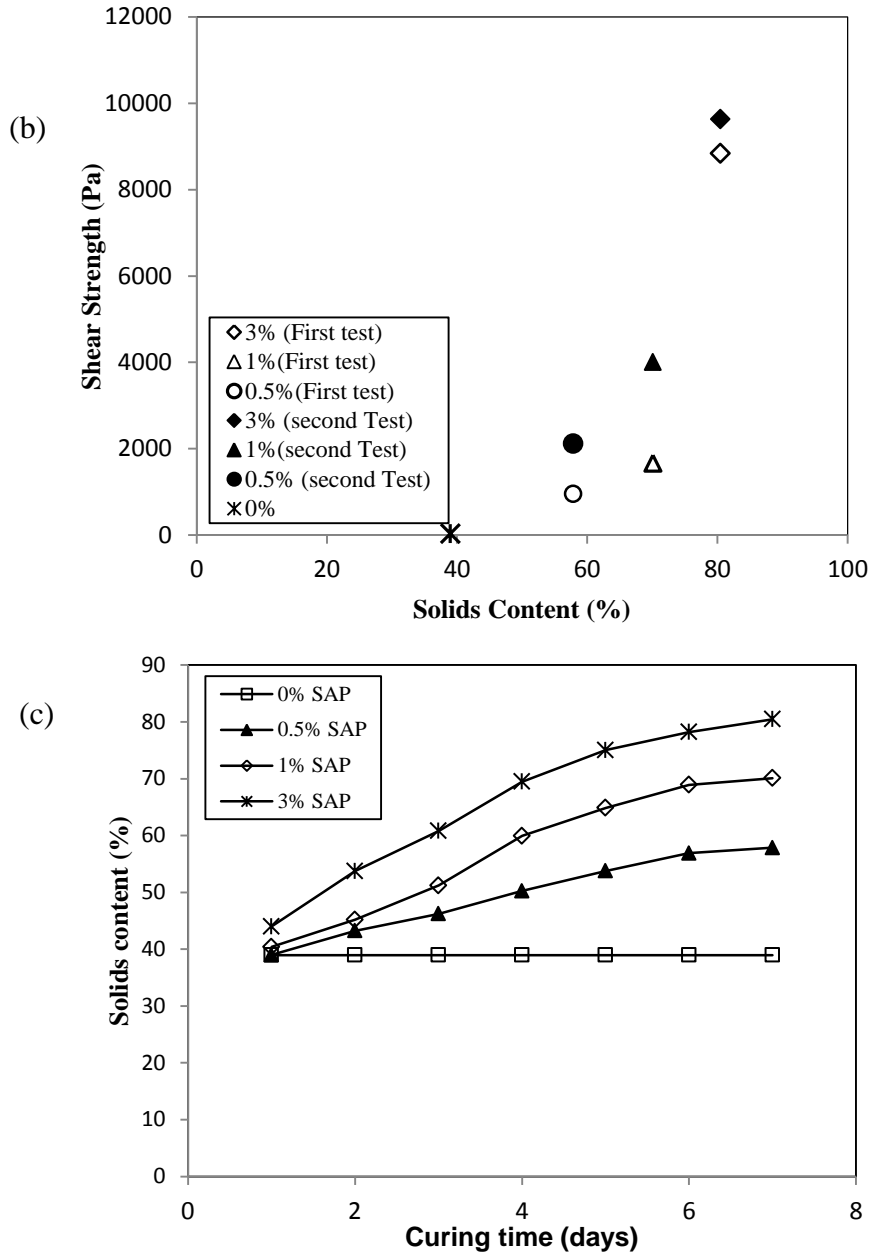

**Fig. 3.7a** Shear strength of MFT treated with SAP sachet versus curing time, **Fig. 3.7b** MFT shear strength versus solids content for the first (after 7 days) and second test (after 14 days), **Fig. 3.7c** Solids content of MFT treated with SAP sachets versus curing time

The increase in the shear strength of the MFT after 7 days of rest (after separation of the SAP sachets) is directly related to the formation of the structure within the MFT. As the structure of any soil is dependent on the interaction forces between soil particle, soil water and their adsorption complexes (Punmia et al. 2005), electrostatic bonds between the clay particles and

polyvalent cations ( $\text{Ca}^{2+}$ ,  $\text{Mg}^{2+}$  and  $\text{Al}^{3+}$ ) have a significant influence on the structure of MFT. In the indirect method, the formation of these bonds is disturbed by mixing the MFT- sachets during the first 4 days. Thus, more time is needed to form a strong structure and samples that had rested for 10 days (3 days with SAP sachets and 7 days without SAP sachets) showed higher shear strength compared to those that were allowed to rest for only 3 days (with SAP sachets).

The shear strength of MFT treated with SAP sachets showed a significant improvement compared to the direct treatment method. This can be due to the fact that the absorbed water and swollen polymer are separated from the tailings; as a result, the solids content of the MFT will increase. One of the difficulties in using the SAP sachets is the decrease in the contact area between the SAP and tailings, which was improved by mixing. The duration of the mixing was determined to have an effect on the dewatering process. To attain the vital contact area, a mixer was used for 10 minutes in the first 4 days of the dewatering.

The solids content of the fine tailings that are shown in Fig. 3.7c illustrate the effect of the mixing. As the solids content of the MFT during the first 4 days has increased around 15% compared to previous days, this proportion decreases to less than 8% on the fifth day. By comparing Figure 3.5b with Fig. 7c, it can be found that the solids content of the tailings cured with SAP sachets shows a significant increase compared to that obtained by the direct method. This comparison is shown in Fig. 3.8, where the solids content of the MFT with 3% polymer is increased up to 61% with the direct method versus 80% with the indirect amendment. Also, the samples with 0.5% and 1% SAP show a 9% and 14% improvement. This difference can be due to the fact that in the direct mixing of tailings and SAP, it is almost impossible to separate the swelling gel from the fine tailings, and as a result, the water would remain in the mixture within the polymer chains.

During the process of dewatering the MFT by using the SAP sachets, all of the samples were completely sealed and the effect of evaporation was not taken into account. Evaporation can highly decrease the water content and improve the densification and strength of MFT. In addition, the obtained results show a significant advantage when the indirect method is used, as the samples present high undrained shear strength after 14 days. This is a great improvement compared to the one year requirement in the ERCB (2009) for MFT to reach 5 kPa.

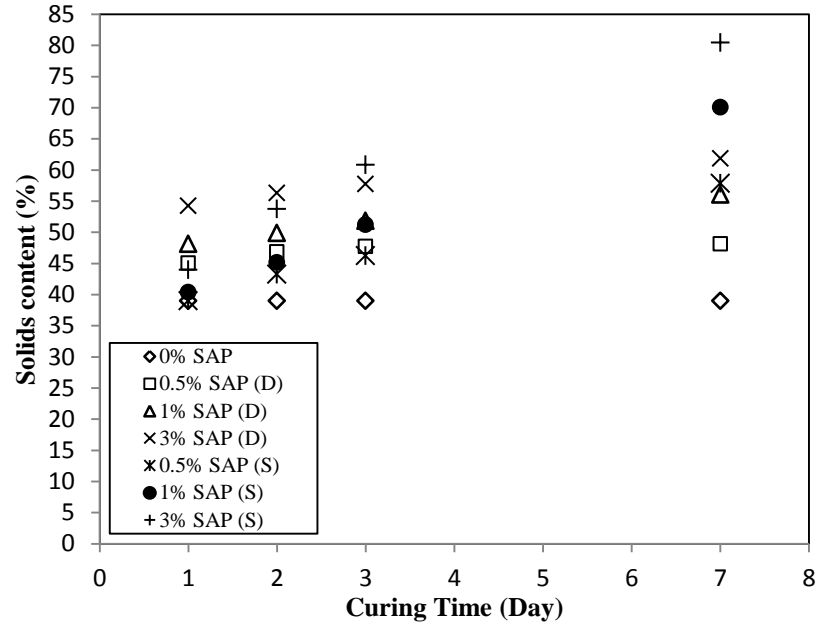

**Fig. 3.8** Solids content of MFT directly mixed with SAP (D) and MFT mixed with SAP sachets (S) versus curing time

### 3.3.3 Effect of freeze/thaw

#### Effect of freeze/thaw cycles on SAP-MFT (direct method)

The effects of freeze/thaw cycles on the undrained shear strength of SAP-MFT are illustrated in Figure 3.9. As shown in Fig. 3.9a, the application of one freeze/thaw cycle on 0% SAP-MFT increases its strength from 30 Pa to a value close to 300 Pa, and the second cycle improves the strength to 500 Pa. The results obtained for the 0.5%, 1%, and 3% SAP-MFT samples predicted the ability to dewater in the second freeze/thaw cycle to be less than the first cycle. The reason for this can be attributed to the decrease in the water content after the first cycle which will reduce the available water to be drained. By conducting the second cycle of freeze/thaw on one day cured samples, the shear strength of the 3% SAP-MFT sample reaches 5.8 kPa, while that of the 0.5% and 1% samples remain under 5 kPa.

Fig. 3.9(b) presents the result of vane shear testing on 3 day cured samples and the effect of freeze/thaw on the strength of the MFT. As shown in the figure, the samples with 0.5%, 1% and 3% SAP are able to endure 2.1, 2.9 and 6 kPa of shear stress respectively, after the second thawing process. Based on the results obtained from the first vane shear test, a significant

improvement in the shear strength after 3 days of curing was not expected. This point is illustrated in Fig.3.9(c) where the shear strength of the 3% SAP-MFT sample remains at 6 kPa while the others show minimal improvement.

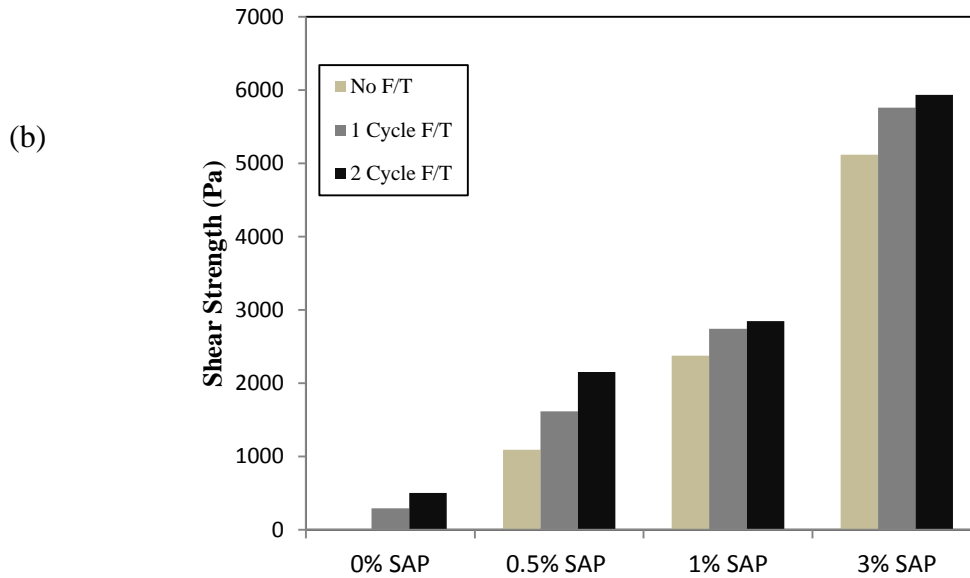
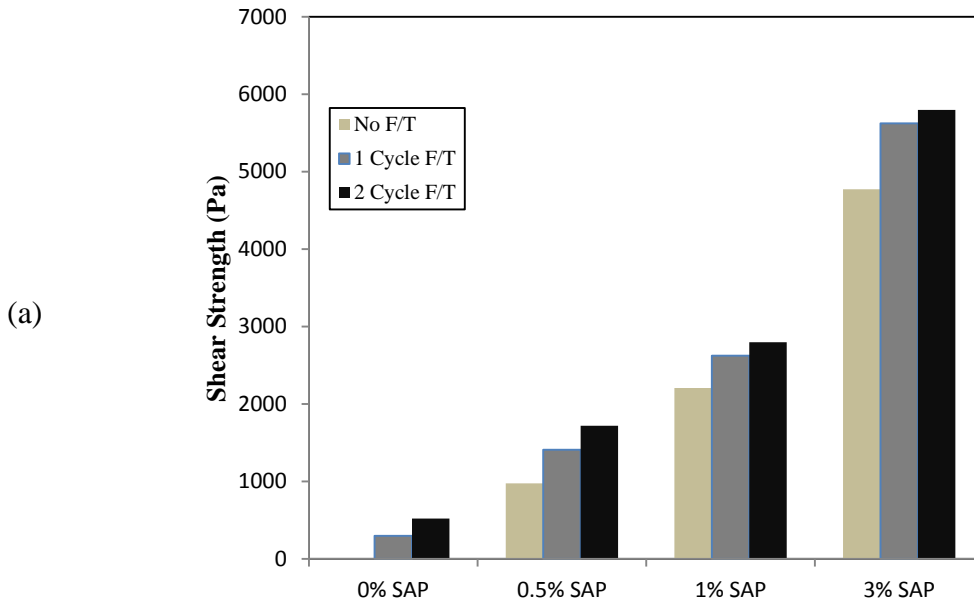

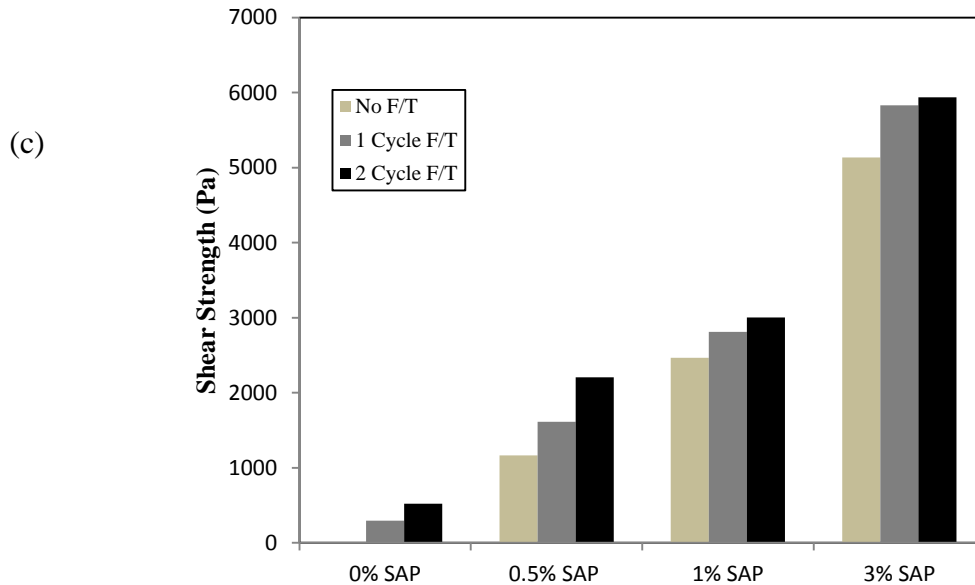
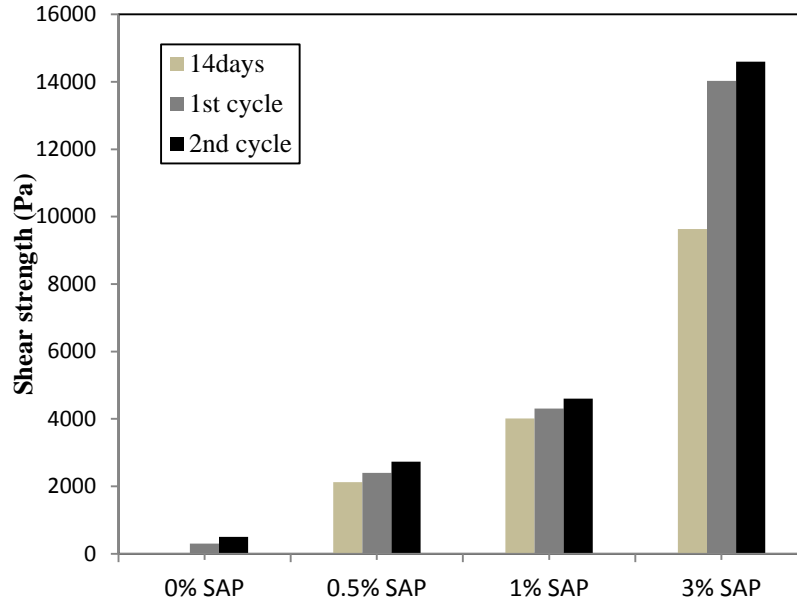

**Fig. 3.9.a** Effect of freeze/thaw on 1 day cured samples, **Fig. 3.9.b** Effect of freeze/thaw on 3 day cured samples, **Fig. 3.9.c** Effect of freeze/thaw on 7day cured samples

### Effect of freeze/thaw cycles on MFT dewatered with SAP sachets

The shear tests were conducted on samples that were cured for 7 days (4 days of mixing) and allowed to rest for another week to rebuild the structure that was disturbed by the mixing. Figure 3.10 shows the effect of two freezing and thawing cycles on the shear strength of MFT with the added SAP sachets. This figure shows a significant increase in the endured stress for all of the samples. Samples with 3% SAP show a dramatic increase of 5 kPa in the first cycle and reach a strength of 14 kPa at the end of second thawing process. This interesting result was derived from the 1% SAP samples that had almost reached the needed 5 kPa of strength at the end of the second cycle.

The solids content of the samples after the first and second cycles is presented in Figure 3.11. It is demonstrated that only one cycle of freeze/thaw on the dewatering of MFT without polymer can increase the solids content from 38% to nearly 45%, and the solids content of the 0.5% SAP samples increased from 57% to 64% at the end of the second cycle. It can be derived from the figure that a higher percentage of polymers will mean less increase in the solids content.



**Fig. 3.10** Effect of freeze/thaw on undrained shear strength of MFT with SAP sachets

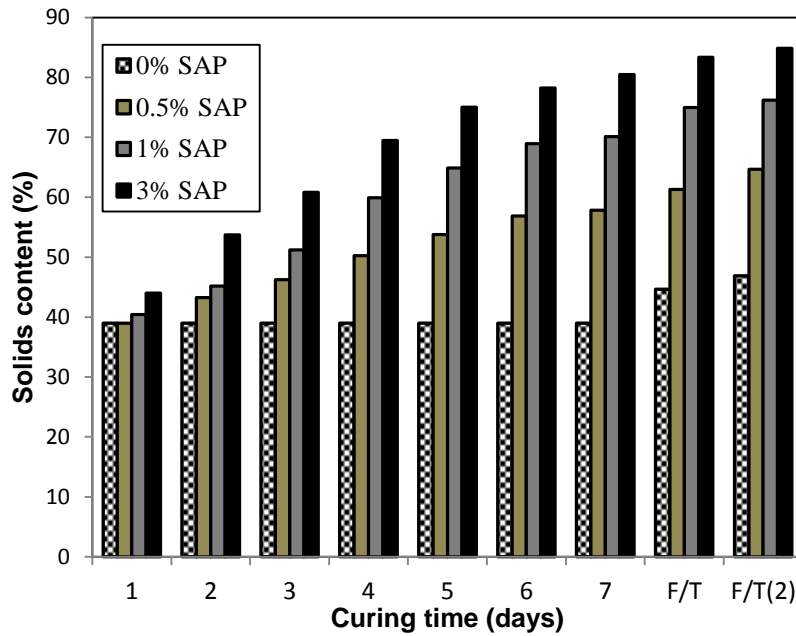
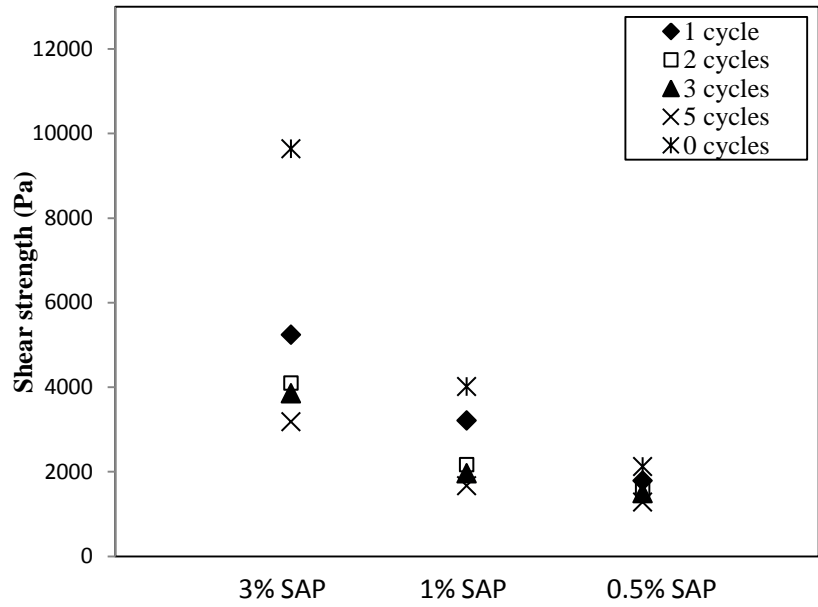

**Fig. 3.11** Effect of freeze/thaw on solids content of MFT with SAP sachets (F/T (first freeze/thaw cycle) and F/T[2](second freeze/thaw cycle))

### **SAP regeneration and effect on shear strength and solids content of SAP-treated MFT**

Based on the results obtained from the preliminary regeneration test, it was determined that temperature-controlled regenerated SAP is more sufficient as it showed higher absorption capacity after several regeneration cycles. Figure 3.12 presents the results of shear strength testing on MFT that was dewatered by using the regenerated polymer. As shown in the graph, the shear strength of the cured MFT decreases as the regeneration cycles increase due to the reduction in the absorption capacity of the regenerated polymer. This reduction in the absorption ability of the SAP is due to the trapped ions that remain in the polymer chains after dewatering the SAP (Dzinomwa et al.1997). The number of ions gradually increases during each cycle and reduce the capacity of the SAP to absorb. Retained ions are bonded to the molecules of the liquid, which will not be released during the desorption process and lead to a slight increase in the weight of the SAP (Dzinomwa et al. 1997).

A significant decrease in the shear strength occurs after the first regeneration cycle and is more significant in the samples with 3% polymer. As derived from the figure, the shear strength of the sample with 3% SAP decreases from 14 kPa to 5.5 kPa in the first cycle while all of the other samples can endure stresses less than 5 kPa. The pattern of the reduction in the solids content of the samples is less fluctuating and follows the same rate for all the samples as presented in Figure 3.13, although it is slightly more noticeable in samples with high SAP content. It should be emphasized that despite this observed drop in strength as the number of regeneration cycle increases, SAP based dewatering still results in a significant increase in the undrained shear strength of MFT. For example, the 3%-SAP MFT samples show a shear strength of over 3000 Pa after five regeneration cycles. This is without considering the positive effect (with regard to strength increase) of freeze/thaw cycles and evaporation, to which the MFT will be exposed in the field.



**Fig. 3.12** Effect of SAP regeneration on shear strength of MFT

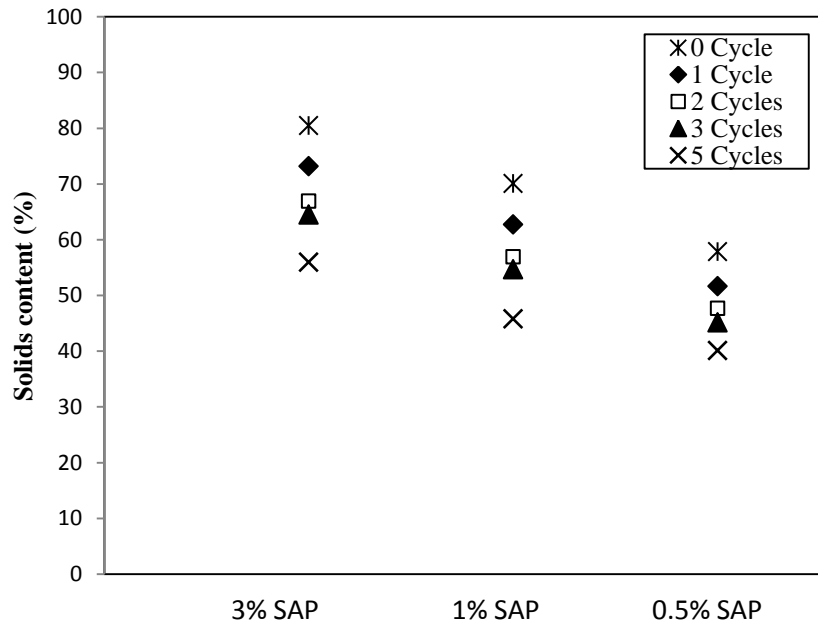

**Fig. 3.13** Effect of SAP regeneration on solids content of MFT

### 3.4 Conclusion

This study has investigated the feasibility of using SAP for the dewatering and densification of oil sand MFT by conducting extensive laboratory tests. Based on the outcomes

obtained, the following conclusions can be drawn:

- rapid and significant dewatering as well as increase in undrained shear strength and solids content of MFT can be achieved by using the proposed SAP dewatering and densification methods (direct or indirect). Better performance with regard to dewatering and increase in strength is obtained with the indirect method,
- freeze/thaw cycles can significantly increase the strength and solids content of MFT dewatered with SAP. This is beneficial for the reduction of SAP dewatering costs, as the required percentage of SAPs will be reduced,
- SAPs regenerated through light thermal drying are also capable of dewatering, and thus increase the strength and solids content of MFT in a significant manner,
- higher strength of MFT treated with SAP should be expected in the field, since the samples tested were not subjected to evaporation, and
- the results place this SAP dewatering and densification method as a promising approach to increase the speed of the dewatering and consolidation processing of MFT, thus increasing the pace of reclamation and reducing the environmental footprint of heavy oil operations in Canada. However, it should be emphasized that further studies should only focus on the indirect dewatering method. This method provides better performance and allows the recycling of SAP, which is critical for the economic feasibility of the SAP dewatering technique. Moreover, the study and development of various cost-effective dewatering methods of SAP is required. If a cost-effective SAP regeneration technology can be established, dewatering by using highly water-absorptive polymers will probably be put to practical use.

### 3.5 References

- ARK. The ARK Entreprises, Inc. P.O. Box 725, Peculiar, Missouri 6407 (2003).  
[http://www.arkent.com/products/aqua\\_sorb.html](http://www.arkent.com/products/aqua_sorb.html).
- Bakass M., Bellat J.P. and Bertrand G. (2006). "The adsorption of water vapor on super absorbent product at low temperatures and low mass." *Journal of Applied Polymer Science*, 100 (2), 1450-1456.
- Bakass M., Bellat J.P. and Bertrand G. (2007). "Characterization of a superabsorbent polymer." *Journal of Applied Polymer Science*, 104 (2), 782-786.
- Barbour S.L. and Wilson G.W. (1993). "Evaluation of the saturated-unsaturated groundwater conditions of a thickened tailings deposit." *Canadian Geotechnical Journal*, 30 (6), 935-946.
- Caughill D.L., Morgensten N.R., and Scott J.D. (1993). "Geotechnics of nonsegregating oil sand tailings." *Canadian Geotechnical Journal*, 30 (5), 801-811.
- Chalaturnyk R J, Don Scott J. and Ozum B. (2002). "Management of oil sand tailings.", *petroleum science and technology*, 20 (9), 1025-1046.
- Chatterjee P.K. and Gupta B.S. (2002). "Measurement techniques for absorbent material and products." *absorbent technology*, 389-406
- Dawson R.F., Segó D.C., and Pollock G.W. (1999). "Freeze-thaw dewatering of oil sands fine tails." *Canadian Geotechnical Journal*, 36 (4), 578-598.
- Dzinomwa G. P. T., Wood C. J. and Hill D. J. T. (1997). "Fine coal dewatering using pH- and temperature-sensitive superabsorbent polymers." *Polymers for Advanced Technologies*, 8 (12), 767-772.
- ERCB, Directive 074. (2009). *Tailings Performance Criteria and Requirements for Oil Sands Mining Schemes.*, Alberta Energy Resources Conservation Board, Calgary, Alberta, Canada.
- Fall M., Célestin J.C., Han F.S. (2009). "Suitability of bentonite-paste tailings mixtures as engineering barrier material for mine waste containment facilities." *Mineral Engineering*, 22 (9-10), 840-848
- Gosselin P., Hurdey S.E. and Naeth M.A. (2010). "Environmental and health impacts of Canada's oil sand industry." *The royal society of Canada, The academics of Arts, Humanities and sciences of Canada.*

- Hocking, M.B. and Lee, G.W. (1977). "Effect of Chemical Agents on Settling Rates of Sludge from Effluent of Hot-Water Extraction of Athabasca Oil Sands." *Fuel*, 56 (3), 325-333.
- Houlihan R.H, Mian M.H. and Lord E.R. (2010). "Oil sands tailings –technology developments and regulations, , Energy Resources Conservation Board, Canada; E.R. Lord, Canada
- Jewell R., Fourie A. (1999).*Paste and Thickened Tailings - A Guide*, 2<sup>nd</sup> edn., Australian Centre for Geomechanics.
- Mikula R.J., Kasperski K.L, Burns R.D, and MacKinnon, M D. (1996)." nature and fate of oil sands fine tailings." *American Chemical Society*, 251 (14), 677-723.
- NEB. (2000). "Canada's oil sands: A supply and market outlook to 2015." National Energy Board, Alberta, Canada.
- NEB. (2004). "Canada's oil sands: Opportunities and challenges to 2015: an update." National Energy Board, Alberta, Canada.
- NEB. (2006). "Canada's oil sands: Opportunities and challenges to 2015: an update." National Energy Board, Alberta, Canada.
- OSRIN Report. (2010). "Oil Sands Tailings Technology Review." Oil sands research and information network, University of Alberta, School of Energy and the Environment, Edmonton, Alberta. Canada.
- Peer F. and Venter T. (2003). "Dewatering of coal fines using a super absorbent polymer." *The Journal of The South African Institute of Mining and Metallurgy*, 103 (6) 403-410.
- Powter C.B. , Biggar K.W., Silva M.J. McKenna G.T. and Scordo E.B. (2011). "Review of oil sands tailings technology options." In *Tailings and Mine Waste '10.*, Taylor & Francis Group, London.
- Proskin S., Sego D., Alostaz M. (2010). "Freeze–thaw and consolidation tests on Suncor mature fine tailings (MFT)." *Cold Regions Science and Technology*, 63 (3), 110-120.
- Punmia B.C., Jain A. K and Jain A. Kr. (2005). "Soil Mechanics and Foundations:soil structure and clay mineralogy." 16th edn, Laxmi publication, New Delhi, India
- Ratne B.D., Hoffman A.S., Schoen F.J. and Lemons J.E. (2004), "Biomaterials science: an introduction to materials in medicine", Academic press.
- Sadeghi M. and Hosseinzadeh H. (2008). "Synthesis and Swelling Behavior of Starch-Poly (Sodium Acrylate-co-Acrylamide) Superabsorbent Hydrogel." *Turk J Chem.*, 32 (3), 375-388.

- Silva M.J., Biggar K.W. and Jacobsz S.W. (1999). "Plant Dewatering and strengthening of tailing: Laboratory and computer simulation." In *Tailing and waste management*, A.A Balkema, Netherland,315-322.
- ST98-2012. (2012). "Alberta's Energy Reserves 2011 and Supply/Demand Outlook 2012–2021." Energy Resources Conservation Board (ERCB), Calgary, Alberta, Canada.
- Staples T. L., Chatterjee P. K. (2002). "Synthetic super absorbents." In *Absorbent Technology*, 383-318.
- Zohuriaan-Mehr M.J and Kabiri K. (2008,). "Superabsorbent polymer materials: A Review." *Iranian Polymer Journal*, 17 (6), 451-477.

## Chapter 4

### Technical paper II

# Consolidation and hydraulic conductivity of oil sands mature fine tailings dewatered by super absorbent polymer

A. Farkish, M. Fall

**Abstract** - This paper presents the results of experimental investigations on the consolidation behavior and hydraulic conductivity of oil sand mature fine tailings (MFT) dewatered by using a super absorbent polymer (SAP). A comprehensive experimental program that consists of consolidation and hydraulic conductivity tests have been conducted on MFT dewatered with SAP as well as MFT dewatered with SAP and subjected to freeze-thaw cycles. The consolidation behavior and hydraulic conductivity of MFT dewatered by using recycled SAP are also investigated. The obtained results indicate that dewatering by using SAP or a combination of dewatering by using SAP and a freeze/thaw process can significantly increase the solid content and decrease the initial void ratio and compressibility of the MFT. Moreover, the freeze–thaw process can significantly increase the hydraulic conductivity of the MFT, which in combination with reduced compressibility, will improve the MFT consolidation.

**Keywords:** Oil sand; Mature fine tailings; Tailings; Freeze–thaw; Consolidation; Super absorbent polymer; Hydraulic conductivity.

## 4.1 Introduction

As a byproduct of the hot water process (HWP), oil sand tailings are produced in large quantities with very high water content (82% water by weight) which are stored in huge surface ponds (Chalaturnyk et al., 2002). These initial tailings are a mixture of sand, silt and clay particles, residual bitumen and water (NEB, 2000). Solids constitute 55 wt% of the tailings with 82 wt% sand particles and 17 wt% fines (smaller than 44  $\mu\text{m}$ ) thus resulting in a slurry tailing. Once the tailings are discharged into a pond, coarse particles (sand and coarse silt) will settle at

the bottom, quickly forming a beach. On the segregated sands, a layer of suspended fine particles is formed with approximately 20 wt% solids. After a few years of being stored in the ponds, a small portion of the fines will segregate to increase the solid content up to 30 wt% and create a stronger slurry structure (Chalaturnyk et al., 2002). These tailings are referred to as mature fine tailings (MFT) that consist of sand, silt and clay particles, residual bitumen and water. With no further consolidation, the MFT remain a strong suspension of clay particles for several decades (Kasperski, 1992). Due to the high water content, poor consolidation rate and low permeability of the MFT, surface pond disposal cannot be considered as a final waste management technique. Moreover, the undesirable impacts of tailings ponds on air quality, water resources, land use and several other aspects of their surrounding environments emphasize the necessity to dewater MFT and eliminate the ponds.

The dewatering of oil sands MFT is a major environmental challenge for the oil sands industries in Canada. Several studies have been implemented on finding effective techniques to dewater MFT produced in Alberta's oil sand reserves. For example, Johnson et al. (1993) and Dawson et al. (1999) investigated the effect of freeze/thaw on the water release ability and consolidation of MFT. Due to the fact that natural dewatering processes such as freeze/thaw fail to achieve fully desirable results, research was directed toward techniques that significantly change and disturb the suspension structure. Consequently, several different techniques have been introduced and tested. For example, Alamgir et al. (2012) used the Al-PAM assisted filtration system to reduce the inventory of MFT and recycle used water. Guo (2012) assessed the effectiveness and efficiency of the electrokinetic (EK) dewatering of MFT which relies on electro osmotic consolidation. Some of the introduced techniques were tested at a laboratory scale and some were examined in field investigations, but very few of these techniques are commercially used in the oil sands industries. Farkish and Fall (2013) proposed a novel technique of dewatering MFT by using a super absorbent polymer (SAP). They showed that a dewatering technique that uses SAP can considerably increase the solid content and undrained shear strength of the MFT in a short amount of time. Their laboratory test results showed that the solid content of the MFT dewatered by using SAP can reach values up to 80 wt%, whereas their undrained shear strength can reach values between 2 and 10 kPa, depending on the amount of SAP used. These values of shear strength are high compared to the initial undrained shear strength (0.17 kPa) of the untreated MFT as well as the minimum undrained shear strength value

(5 kPa) which the tailings deposited in the previous year must reach according to the criteria set by Directive 074 from the Energy Resources Conservation Board (ERCB 2009). Although this represents a considerable increase in undrained shear strength, the MFT dewatered by using SAP with a strength less than 5 kPa will still have to undergo additional consolidation to reduce its water content and thus increase its shear strength to values higher or equal to 5 kPa. The prediction and computation of void ratio changes and settlement rates of the MFT that result from dewatering by using SAP requires compressibility and hydraulic conductivity data. However, no experimental studies have been carried on the consolidation behavior and hydraulic conductivity of MFT that have been dewatered by using SAP. Therefore, the objectives of this study are:

- (i) to investigate the consolidation behavior of MFT dewatered by using SAP. The effect of the various proportions of SAP, recycled SAP and freeze-thaw cycles on the consolidation behavior of MFT dewatered by using SAP will be assessed, and
- (ii) to determine the saturated hydraulic conductivity of MFT dewatered by using SAP. The effect of various proportions of SAP, recycled SAP and freeze-thaw cycles on the hydraulic conductivity of MFT dewatered by using SAP will be assessed.

## **4.2 Experimental programme**

### **4.2.1 Materials**

#### **Mature Fine Tailings**

In this study, MFT that are produced and stored in the tailing ponds of northern Alberta are used. The MFT were dark grayish brown in color and behaved like a liquid due to the high water content which was determined to be 165 wt%. As shown in Figure 4.1, the primary mineral components of the examined MFT were quartz ( $\text{SiO}_2$ ) and kaolinite ( $\text{Al}_2(\text{Si}_2\text{O}_6)(\text{OH})_4$ ) which constituted 33% and 32% of the mineral content, respectively. The grain size distribution of the tailings presented in Figure 4.2 shows 4% sand, 77% silt and 19% clay particles. The index properties of the MFT were determined by following ASTM D4318 – 10 which showed the liquid limit (LL) and the plastic limit (PL) of the MFT to be 51.2 and 37.2, respectively. Accordingly, the size of the water content range in which the MFT present plastic properties is

14, which means that the MFT have a medium plasticity. The activity of the MFT was determined to be equal to 0.77, i.e., the MFT have normal activity as a result of a high concentration of quartz.

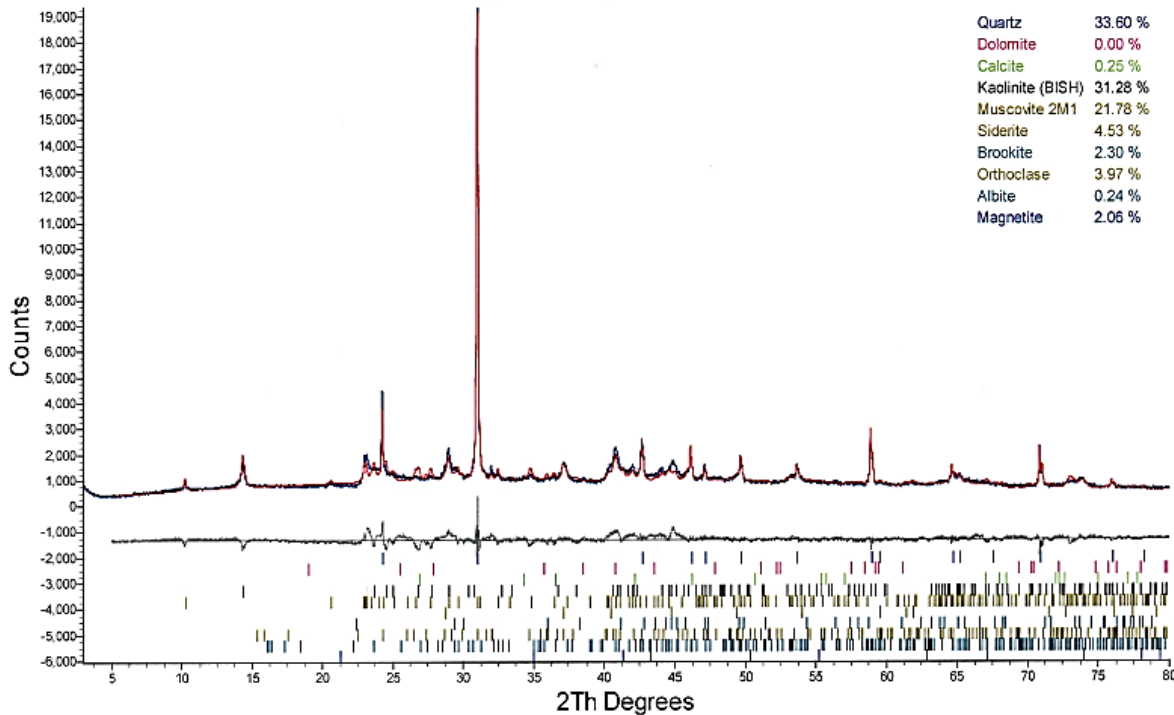

**Fig. 4.1** X-ray diffractogram for the MFT.

Specific gravity tests were conducted by following ASTM D854-02 and the value determined is 2.45 for the MFT. As a result, the tailings are denser than water and ignore the effects of surface tension; thus they will sink in water.

The chemistry of the tailings pore water has a consequential effect on the behavior of the MFT; therefore, influential characteristics of the pore water were investigated. As shown in Table 4.1, the most frequently found elements are sodium, potassium, magnesium and silicate at concentrations of 960,000, 19,000, 13,000 and 8700  $\mu\text{g/L}$ , respectively. The main sources of these elements are bitumen, oil sands connate water (the water trapped among the sand particles) and the HWP. These elements exist in the MFT as organic or inorganic compounds that form an active environment which contributes to the ionic content of the tailings. Most of the sodium ions ( $\text{Na}^+$ ) are the result of added sodium hydroxide ( $\text{NaOH}$ ) during the HWP (Mikula et al., 1996). The pH of the MFT pore water was determined to be 7.9, which provides a sufficient condition

for clay particles to remain in the suspension and increases the concentration of bicarbonates ( $\text{HCO}_3$ ) in the tailings (Hocking et al., 1977; Mikula et al., 1996).

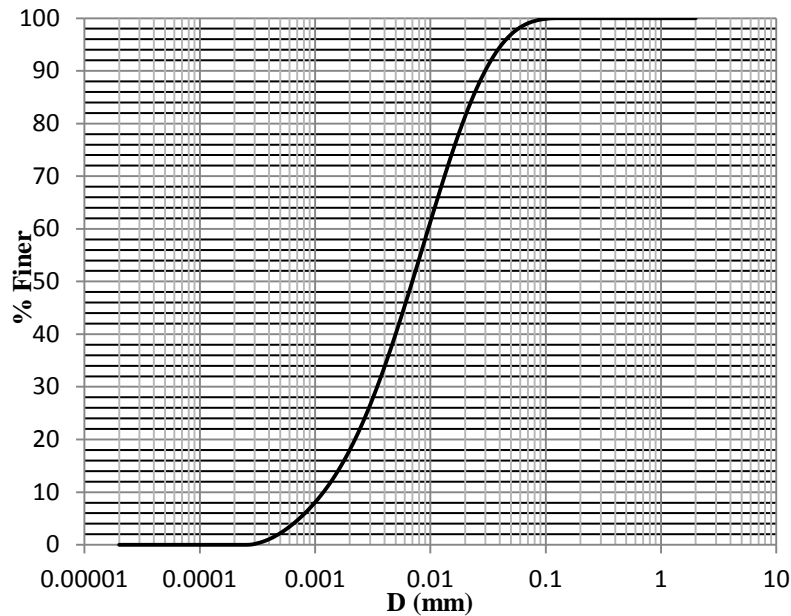

Fig. 4.2 Grain size distribution of the mature fine tailings used

Table 4. 1 Pore water chemistry of the MFT used

Metal	Conc. µg/L	Metal	Conc. µg/L	Metal	Conc. µg/L
Na	960000	Ca	8000	Sr	540
K	19000	Fe	5900	Ba	250
Mg	13000	B	3500	Li	250
Si	8700	Al	2300	P	210

Conc: concentration

### Super Absorbent Polymer (SAP)

SAPs have cross-linked polymer chains and are classified as hydrogels which absorb water by creating strong bonds between hydrogen and water molecules. SAPs are a remarkable class of hydrophilic gels capable of absorbing and retaining great volumes of water or any other fluids (Rosa and Casquilho, 2012). One of the most significant characteristics of SAPs is the swelling capacity which is the increase of volume as a result of liquid absorption. Swelling occurs due to the absorption of a large volume of liquid into the cross-linked network of polymer chains (Rosa and Casquilho, 2012).

The absorption capacity of polymers is resultant of their swelling capacity and the number of cross-links (Staples, 2002). Low density cross-linked polymers present higher swelling and absorption capacity, whereas SAPs with a high density of cross-links have lower swelling and absorption capacity (Staples, 2002). Additionally, the composition of the fluid being absorbed by the SAP is very influential in the absorption capacity of the polymers. Figure 4.3 presents the change in SAP absorption capacity for four different types of water (distilled, tap, 50% MFT water/50% tap water, and MFT water) determined by using the tea bag method. The tea bag method is explained in Sadeghi and Hosseinzadeh (2008). SAPs show lower absorption capacity in ionic fluids; therefore, their highest capacity is reached when absorbing distilled water. As shown in Figure 4.3 after 1 hour of immersion, 1 g of SAP absorbs almost 270 g of distilled water, and as the ionic content of the liquid increases, the absorption capacity consequently decreases. In considering this reduction, 1 g of SAP absorbed a significant amount of MFT water (110 g) after 1 hour of immersion, which indicates the ability of the SAP to significantly dewater oil sands MFT.

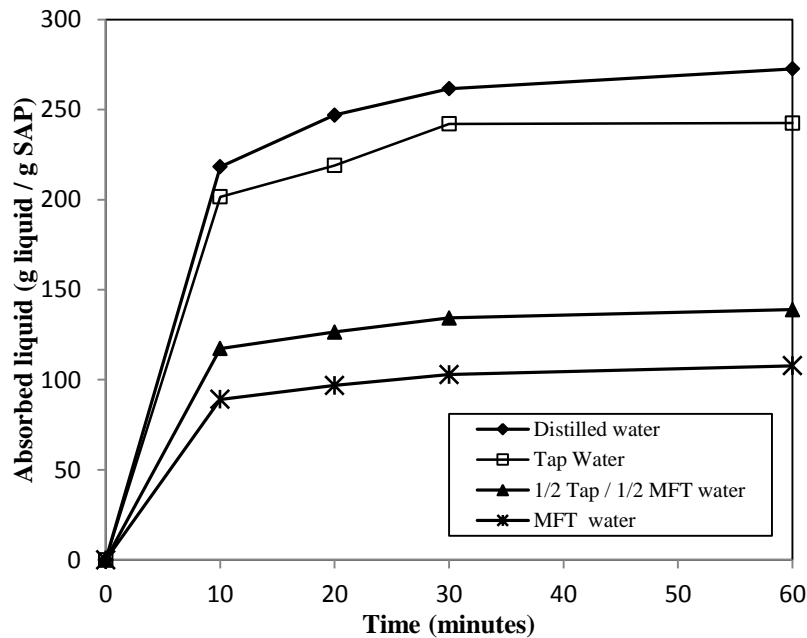

Fig. 4.3 Absorption capacity of the SAP

#### 4.2.2 SAP dewatering process

MFT dewatering was conducted by using SAP to reduce the amount of water trapped in the MFT. Known amounts of SAP were placed into sachets, and then these sachets were mixed

with a certain amount of MFT. The weight proportions of SAP in the tailings were 0%, 0.5%, 1% and 3%. The MFT and SAP sachets were stored in sealed containers for 14 days. During the first 4 days, the SAP and MFT in the sachets were mixed by using an electric mixer for 10 minutes each day. Mixing was done to increase the contact between the SAP and MFT in order to intensify the dewatering process. After 7 days, the SAP sachets were removed and MFT samples were taken at the end of 14 days to conduct the consolidation and hydraulic conductivity tests.

### **4.2.3 Freeze/thaw dewatering**

As the second dewatering technique, the freeze/thaw process was used to strengthen the effect of dewatering by using SAP and increase the solidification rate of the MFT. Freeze/thaw cycles occur in northern Alberta as a result of weather and temperature changes during the year. In the winter, cold weather results in the freezing of MFT stored in surface tailings ponds which enables water to separate from the suspended solids. As a result, a network of thin icy canals is created within the MFT layers. When the temperature rises, the remaining cracks would enable water to drain from the tailings or rise to the surface to evaporate (Johnson et al., 1993).

For dewatering by using the freeze/thaw process, the MFT was first mixed with the SAP sachets. The SAP-MFT mixtures were prepared with four different weight proportions of SAP, 0% 0.5%, 1% and 3%. The resultant mixtures were stored in 40 x 20 cm rectangular containers for 7 days. Each container contained approximately 6 kg of the SAP-MFT mixture with a thickness of 20 cm. The SAP sachets and MFT were mixed for the first 4 days and the sachets were removed at the end of the 7 days. The MFT which were dewatered first by the SAP, were then subjected to freeze-thaw cycles. During the freeze-thaw application, the method introduced by Johnson et al. (1993) was followed. The containers were moved into a freezer where they were kept at -24°C for 24 hours. Thawing was carried out at room temperature (23°C) until all of the frozen water melted (approximately 24 hours).

A simple drainage system was designed to enable the water to exit the MFT. The bottoms of the containers were removed and replaced by metal nets covered with a 2 cm layer of sand topped with filter paper. To accelerate the removal of water that had accumulated on top of the MFT, a slight slope (2%) was made by putting metal shims under the one end of the

containers. Two freeze thaw cycles were conducted on the MFT and samples were taken at the end of each cycle to evaluate the hydraulic conductivity and consolidation behavior.

#### **4.2.4 SAP regeneration process**

SAPs are used in various products and industries, such as in personal care products and drugs, as well as in agriculture, and waste water and solid waste treatment. Regardless of the function, environmental feasibility and reusability of SAPs are important if they are used often in various products. The desorption ability of SAPs enables the removal of absorbed fluid and reuse of the polymers for further absorption and dewatering. The reusing of SAPs will help to preserve the environment, prevent the disposal of useful materials, reuse released water and reduce the cost of application.

SAPs can be recycled by using two methods: temperature induced and pH induced methods (Farkish and Fall, 2013). However, studies performed by Farkish and Fall (2013) have revealed that the former works much better (higher water absorption capacity of the recycled SAP, lower cost) than the latter. Therefore, the temperature induced method was selected and tested.

To assess the effect of temperature based SAP recycling on dewatering, 1 g of polymer was immersed into fluid for 30 minutes. Two different types of fluids (tap water and MFT water) were used to evaluate the effect of fluid composition on the desorption process. After half an hour, the SAP sachets were separated from the water and placed into an oven at 65°C for 36 hours to release the absorbed water. By recording the weight loss of the SAP through time, the actual time period required for desorption was determined, and by repeating the process, the reduction of the absorption capacity of the polymer was derived.

Figure 4.4 presents the change in the absorption capacity of the SAP by the temperature induced method after 5 cycles of dewatering and reusing. This figure illustrates that the absorption capacity of the SAP is less for MFT pore water (106 g liquid/g SAP) compared to distilled water (270 g liquid/g SAP), although a significantly high absorption ability of the SAP can still be shown by the former. Also, as expected, the absorption capacity of the SAP decreased after each regeneration cycle. This reduction in absorption ability is due to the trapped ions that remain in the polymer chains after dewatering (Dzinomwa et al., 1997). The number of

ions gradually increases during each cycle and thus reduces the capacity of the SAP to absorb. Retained ions are bonded to the molecules of the liquid, which will not be released during the desorption process and lead to a slight increase in the weight of the SAP (Dzinomwa et al., 1997).

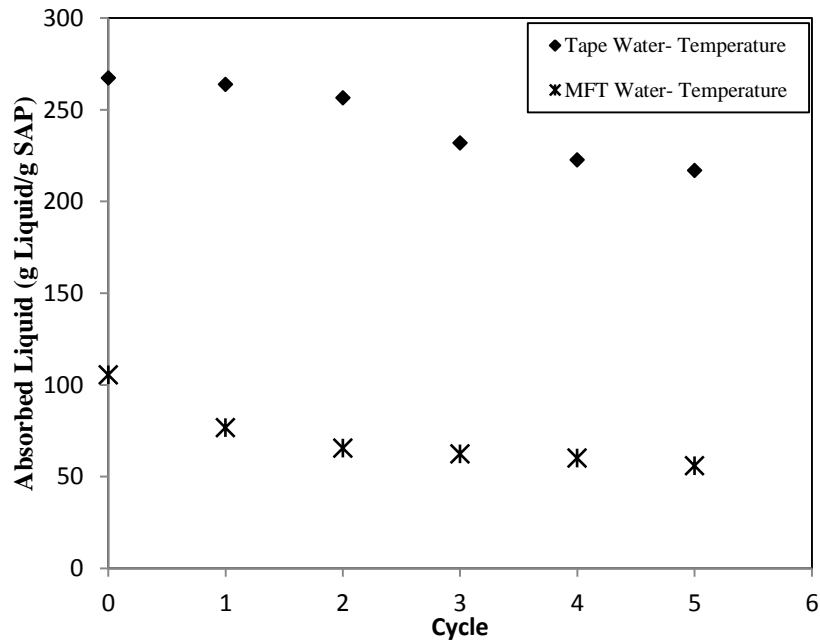

**Fig. 4.4** Change in the absorption capacity of the SAP as a result of regeneration cycles

Regardless of the initial absorption capacity, the reduced rate of absorption for both types of liquids after five regeneration cycles is almost the same and the resultant SAP was able to retain a granular shape and preserve its structure. Based on the results and observations, the temperature induced method for SAP recycling is proven to be feasible, and therefore, is used as the primary recycling technique in this study.

#### 4.2.5 Specimen preparation

taking of undisturbed samples is highly important to determine hydraulic conductivity and the consolidation behavior of soils since even a small disturbance may change the void ratio and/or pore structure of the soil sample which will affect the result for both tests. Sampling was carried out based on ASTM D2435/D2435M – 11 by using a consolidation ring and flexible spatula and trimmer. For each combination of SAP or recycled SAP proportions (0%, 0.5%, 1%, and 3%), two samples were prepared to demonstrate the repeatability of the results. Cylindrical

specimens that had a diameter of 63.5 mm and length of 25 mm were prepared to accommodate the large deformations associated with the relatively low solid contents of fine tailings.

#### 4.2.6 Testing of the specimens

To investigate the permeability and compressibility behaviors of the material in question, hydraulic conductivity and consolidation tests were conducted. The Terzaghi consolidation theory cannot accurately model MFT consolidation due to large strains, nonlinear compressibility and hydraulic conductivity, and the self-weight consolidation associated with the MFT (Proskin et al., 2010). Therefore, an alternative method is required to demonstrate the compressibility characteristics of MFT. Carrier et al. (1979) and Pollock (1988) introduced a new method to obtain the permeability and compressibility data without resorting to the Terzaghi consolidation theory for data analysis. This study follows the same procedure introduced by Pollock (1988) which involves the consolidating of the specimen with incremental loading and directly measuring the hydraulic conductivity by using a constant head test. These tests will illustrate the change in void ratio as effective stress and permeability vary. The apparatus used for this study allows one to obtain void ratio versus effective stress and enables hydraulic conductivity testing to be conducted in each stage (Figure 4.5).

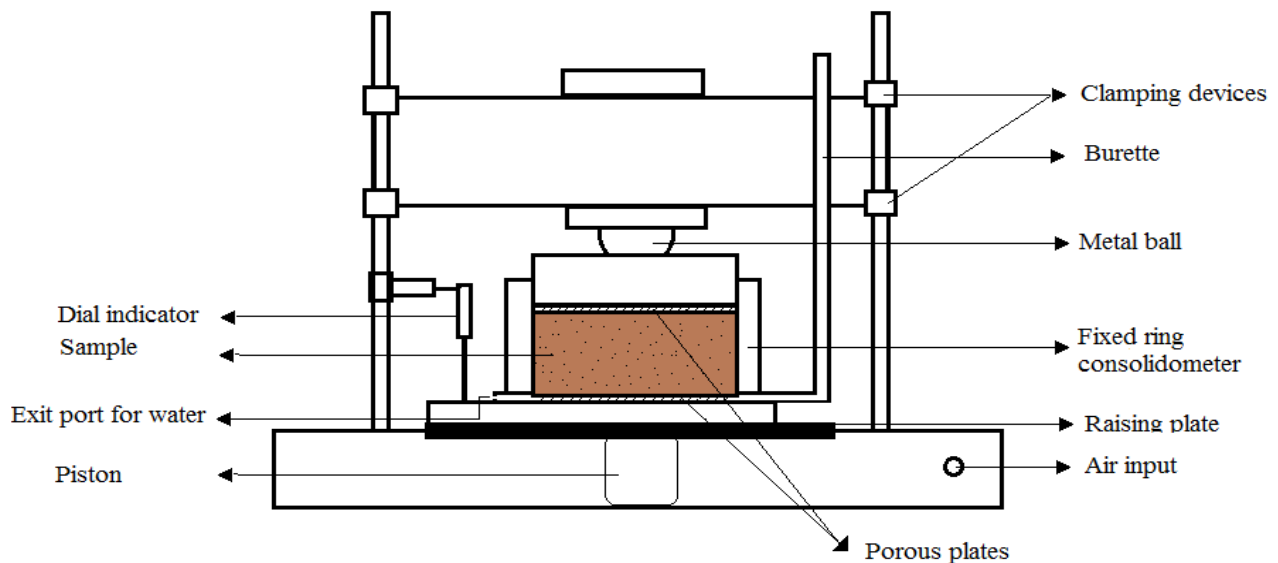

**Fig. 4.5** Apparatus used for consolidation and hydraulic conductivity tests

## **Consolidation test**

The consolidation cell consists of a ring and two porous stones for the top and bottom of the specimen (Figure 4.5). The top porous stone is connected to the top (loading) cap that is made of stainless steel and has a convex area on top for the metal ball to settle. The metal board located at the top of the apparatus can be moved vertically and fixed in a perfect position on top of the metal ball surface. Both the top and the bottom caps have grooves to accelerate the transfer of water from the MFT. The ring can contain specimens that are 63.5 mm in diameter and 25 mm in length. The piston and diaphragm are located beneath the consolidation cell connected to an air supply. Controllable air pressure provides the force for the piston to push the consolidation cell upward where it is stopped by the metal board. Consequently, specific amounts of pressure will cause the specimen to consolidate.

The specimens underwent seven days of self-weight consolidation, starting from the removal of the SAP sachets and excluding the 24 hours of freezing for the freeze-thaw dewatered MFT. Later, they were consolidated under a vertical seepage gradient until they were capable of undergoing the initial step of loading. The specimens were subjected to five different effective stresses: 5, 10, 20, 50 and 100 kPa, by following the procedure described in ASTM D2435/D2435M – 11, and a dial indicator was used to monitor the displacement of the surface of the MFT with time. For each increment, a double drainage system was provided at the top and bottom of the cell. By repeating this procedure, the deformation of the specimens under each amount of effective stress was derived and the void ratio versus effective stress was determined.

## **Hydraulic conductivity test**

Constant head permeability tests were conducted after each step of loading to determine the hydraulic conductivity for each effective stress. One of the problems associated with performing hydraulic conductivity on slurries is the occurrence of consolidation as a result of hydraulic gradients (Pollock, 1988). To resolve this issue, the loading cap was fixed during the permeability test, and also the flow in the constant head was upward. The standard procedure for the permeability test is described in ASTM 2434. After the loading up was fixed, flow was allowed and reading was delayed until a desirable head condition without a noticeable drift in the water level was attained. By using a stop watch, the amount of time to reach the constant head was recorded ( $t$ ) and by using the surface area of the specimen ( $A$ ) and volume of the flow ( $\Delta V$ ),

the hydraulic conductivity can be calculated by using the following equation which is a rearrangement of Darcy's law:

$$\text{Eq (4.1) } k = \frac{\Delta V}{i.A.t}$$

Where  $i$  is the hydraulic gradient equal to the hydraulic head difference ( $\Delta h$ ) divided by the height of the specimen.

At the completion of each hydraulic conductivity test, the loading device was released and the next effective stress was applied. Once the consolidation increment was completed, the device was locked and a permeability test was carried out for the effective stress and void ratio. By repeating this procedure, the hydraulic conductivity ( $k$ ) versus void ratio for each specimen was derived.

### **4.3. Results and discussion**

#### **4.3.1 Consolidation behaviour of MFT treated by SAP**

##### **Consolidation Behaviour of MFT dewatered by SAP sachets**

From the MFT dewatered by the SAP sachets, three types of specimens (0.5% SAP, 1% SAP and 3% SAP) were prepared and tested. The void ratio versus log effective stress data for these samples are plotted in Figure 4.6 along with data from Suthaker and Scott (1994) and Proskin et al. (2010) for the MFT with no treatment. Despite being consolidated with the same effective stress, each specimen shows a unique consolidation curve due to the difference in solid content and initial void ratio. As shown in Table 4.2, specimens with higher initial solid content have a lower void ratio and show less compressibility. As shown in Figure 4.6, higher solid content results in higher pre-consolidation pressure ( $\sigma'_p$ ) and lower slope of the virgin consolidation line.

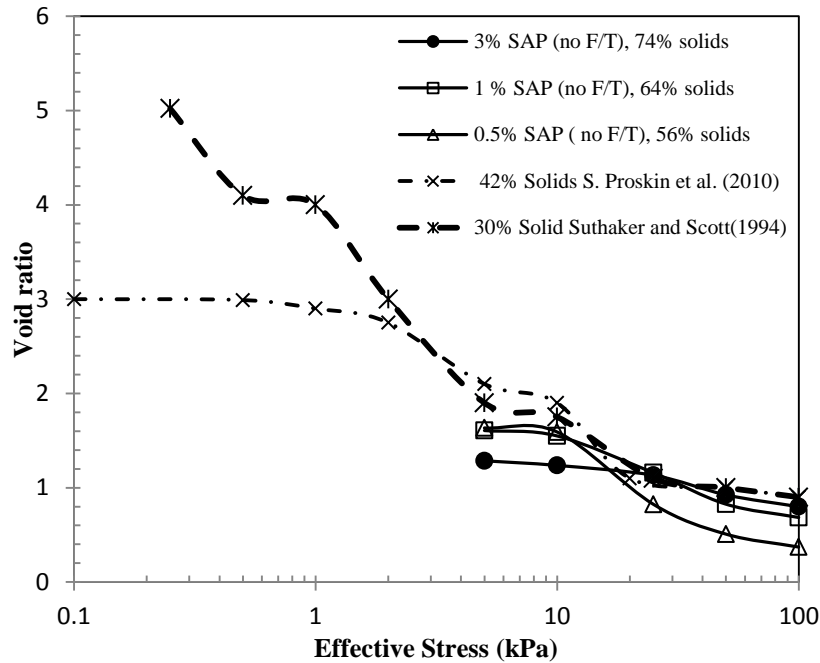

Fig. 4.6 Consolidation test results for MFT treated by SAP sachets

Table 4.2 Properties of consolidation test specimens

	Pre-consolidation properties			Post consolidation properties		
	Solid content (%)	Void ratio	Saturation (%)	Solid content (%)	Void ratio	Compression Index, Cc
MFT- 0.5% SAP	56	1.91	90.0	70	0.37	1.30
MFT- 1% SAP	64	1.87	93.0	76	0.68	0.57
MFT-3% SAP	74	1.29	91.2	82	0.79	0.37
Proskin et al. (2010)	42	3.00	N/A	N/A	0.90	1.1
Suthaker and Scott (1994)	30	5.02	N/A	N/A	0.92	1.7

### Consolidation behaviour of MFT treated by recycled SAP

As expected, the change in the void ratio over the effective stress was highly affected by the solid content of the MFT. Due to the reduction in the absorption capacity of recycled SAP, the solid content of these samples was lower than those treated with SAP that was not recycled.

Consequently, sampling was difficult and unlike the rest of the samples, saturation was not an issue. Figure 4.7 shows the compressibility behavior of MFT dewatered 5 times with recycled SAP in a plot with void ratio versus log effective stress. The initial void ratio ( $e_0$ ) of these specimens is the highest among all the other samples, which ranges from 2 to 3.2 (Table 4.3). The high compressibility of these specimens forms a large slope in the virgin consolidation line of the curves, thus resulting in a large compression index. The figure shows that the change in void ratio ( $\Delta e$ ) over the same stages of effective stress is almost halved as the solid content changes from 42 wt% to 52 wt%.

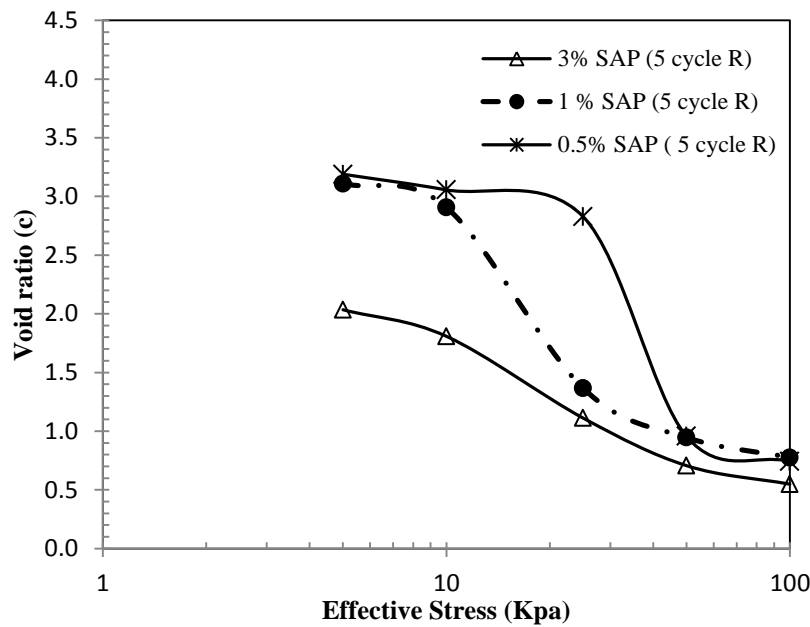

Fig. 4.7 Consolidation test results for MFT treated by recycled SAP

Table 4.3 Properties of consolidation test specimens

	Pre consolidation properties			Post consolidation properties		
	Solid content (%)	Void ratio	Saturation (%)	Solid content (%)	Void ratio	Compression Index
MFT- 0.5% SAP	43.0	3.20	100.0	79	0.74	3.00
MFT- 1% SAP	44.0	3.14	99.2	73	0.77	1.30
MFT-3% SAP	52.0	2.04	98.0	74	0.54	0.56

### Consolidation behaviour of MFT treated by SAP and subjected to freeze/thaw

As shown in Figure 4.8, the consolidation curve of the MFT dewatered by a combination of SAP and the freeze/thaw process is similar to that of the classic soil plots. The ability of the MFT to resist compression will decrease due to the increase in solid content. Table 4.4 presents the properties of samples subjected to the freeze/thaw process and by comparing the data to those presented in Table 4.2, it can be noticed that one cycle of freeze/thaw can decrease the initial void ratio of the samples by a factor of 1.3 to 1.4.

Figure 4.8b illustrates that the curve defined by the specimens subjected to two cycles of freeze/thaw has a lower slope than the curve of specimens subjected to one cycle, thus inferring that these specimens are less compressible. The lower compressibility of these specimens is a result of the low initial void ratio and high solid content caused by an extra cycle of freeze/thaw.

**Table 4.4** Properties of consolidation test specimens

	Pre consolidation properties			Post consolidation properties		
	Solid content (%)	Void ratio	Saturation (%)	Solid content (%)	Void ratio	Compression Index
<b>MFT- 0.5% SAP (1c)</b>	65	1.41	92	75	0.65	0.75
<b>MFT- 1% SAP (1c)</b>	69	1.33	83	76	0.47	0.80
<b>MFT-3% SAP (1c)</b>	72	1.03	95	82	0.62	0.53
<b>MFT- 0.5% SAP (2c)</b>	68	1.06	99	79	0.47	1.15
<b>MFT- 1% SAP (2c)</b>	73	1.04	89	78	0.64	0.53
<b>MFT-3% SAP (2c)</b>	77	0.96	86	84	0.58	0.27

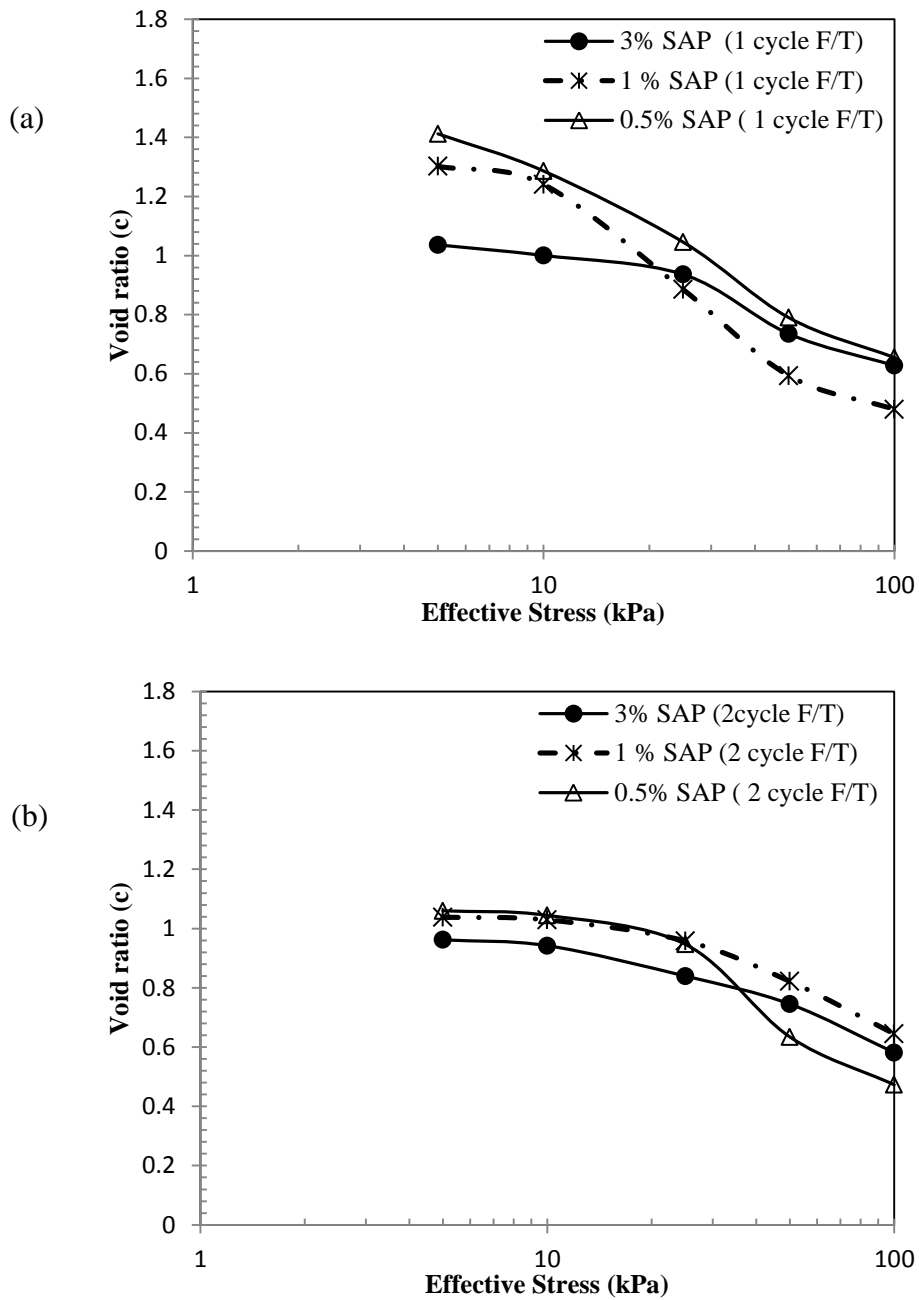

**Fig. 4.8 (a).** Consolidation test results for MFT dewatered by SAPs and 1 cycle of freeze/thaw  
**(b).** Consolidation test results for MFT dewatered by SAPs and 2 cycles of freeze/thaw

### 4.3.2 Hydraulic conductivity of MFT treated by SAP

#### Hydraulic conductivity of MFT treated by SAP sachets

The effects of the initial solid content and void ratio on hydraulic conductivity were investigated by using three different proportions of SAP in the sachets for the dewatering of MFT. Figure 4.9 shows the void ratio ( $e$ ) versus hydraulic conductivity ( $k$ ) for the MFT dewatered by the SAP sachets. Along with these data are the results from Suthaker and Scott (1996) for MFT with 30% solid content. The obtained data seem to follow the same curve derived from the data by Suthaker and Scott (1996). These data indicate that decreases in void ratio mean that the hydraulic conductivity will decrease as well. Overall, the hydraulic conductivity of the MFT samples is very low ( $< 10^{-6}$  cm/s) due to the high concentration of fines (Suthaker and Scott, 1996).

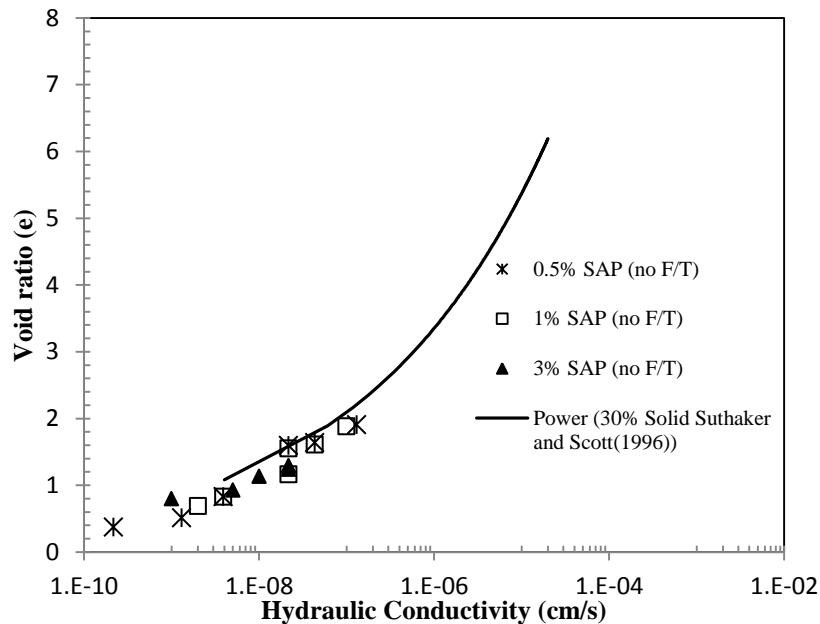
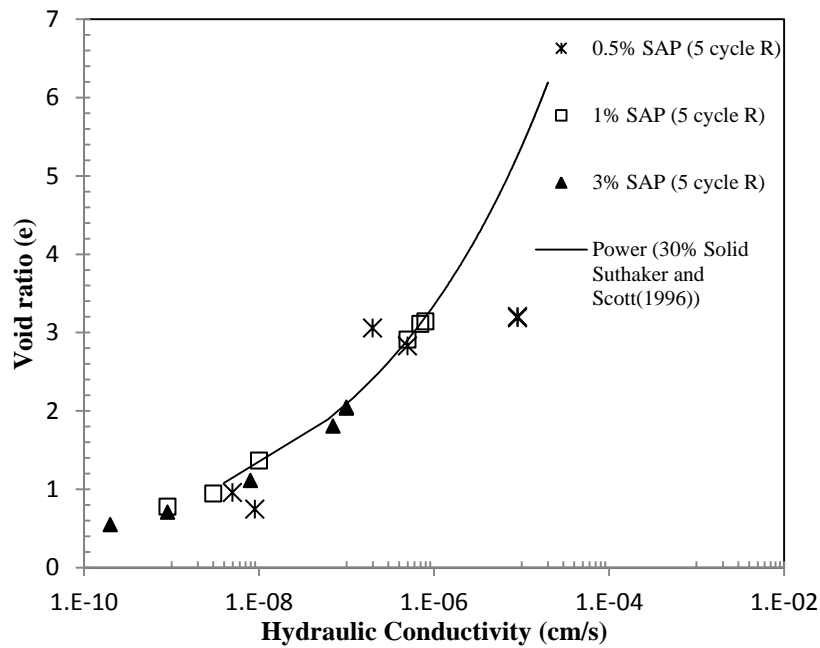

Fig. 4.9 Hydraulic conductivity test results for MFT dewatered by SAP sachets

#### Hydraulic conductivity of MFT treated by recycled SAP

Figure 4.10 presents the results for the permeability testing of the MFT dewatered by regenerated SAP. These data seem to be more scattered, specifically for specimens dewatered with 0.5% SAP which can be due to the high suspended fine particles and initial void ratio. The MFT samples dewatered with recycled SAP show higher permeability compared to the other

samples due to the lower absorption capacity of the recycled polymers. As a result, these specimens have higher hydraulic conductivities ( $k$ ) by a factor of 2 in comparison with the MFT dewatered with non-recycled SAP and by a factor of 3 compared to the SAP treated MFT subjected to the freeze/thaw process. As mentioned by Suthaker and Scott (1996), the hydraulic conductivity of fine tailings depends on the hydraulic gradient; therefore, it does not conform to Darcy's law. The hydraulic gradient influences the deformation of bitumen in the pore throats. Under an applied gradient, bitumen globules will deform, and when the gradient is removed, they will recover back to their original position. As a result, with higher void ratios, the effect of hydraulic gradients is more significant due to the fact that bitumen globules have more space to deform.



**Fig. 4.10** Hydraulic conductivity test results for MFT dewatered by recycled SAPs

### Hydraulic conductivity of MFT treated by SAP and subjected to freeze/thaw cycle

The results of the hydraulic conductivity testing for the MFT samples dewatered with SAP and subjected to the freeze/thaw process are shown in Figure 4.11. Unlike the other samples, these show higher hydraulic conductivity despite a lower void ratio. As shown in the graphs, the permeability of the MFT decreases as effective stress increases (low void ratio), although this reduction is slower in the samples that underwent the freeze/thaw process. As a

result, the obtained data do not follow the same curve as the one fitted by Suthaker and Scott (1996). The obtained data follow a curve with a lower slope than the data for samples dewatered with solely SAP or with data from Suthaker and Scott (1996). The reason for this difference can be found in the altered soil fabric of the MFT due to the freeze/thaw cycle (Proskin et al. 2010). Ice networks created during the freezing process (which work as drainage channels during thawing) create interconnected voids filled with pore fluid. During low effective stress, the peds of the MFT are able to maintain the arrangement of connected voids and result in a higher void ratio for the same load under low effective stresses. However, under high effective stresses, these inner structures will collapse, thus resulting in a significant reduction of hydraulic conductivity (k) (Proskin et al., 2010).

Sudden reductions in hydraulic conductivity can be seen by the gap created among the data when approaching higher effective stresses (low void ratios) and data obtained in lower effective stresses (higher void ratios).

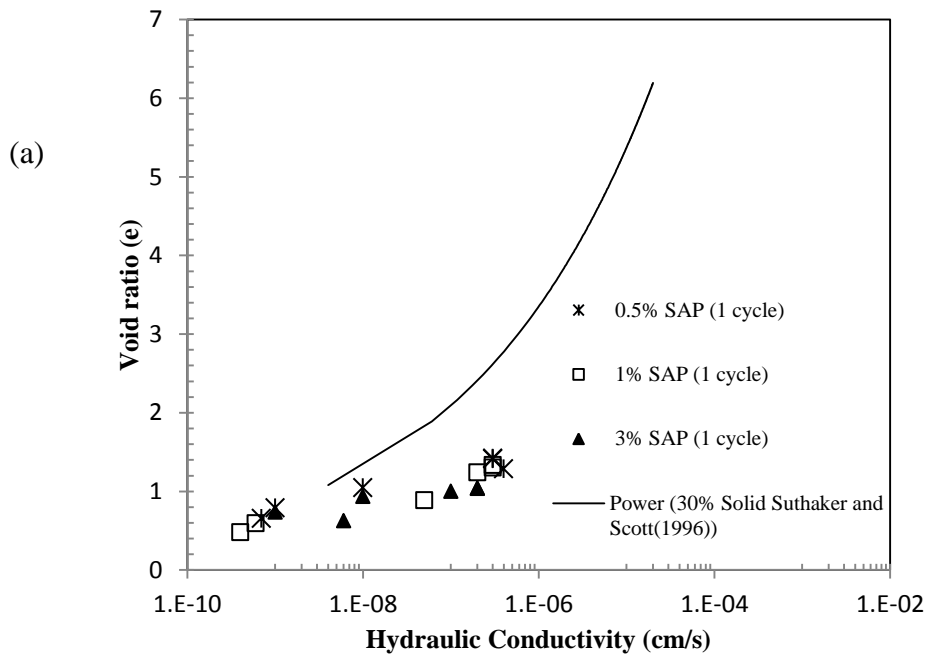

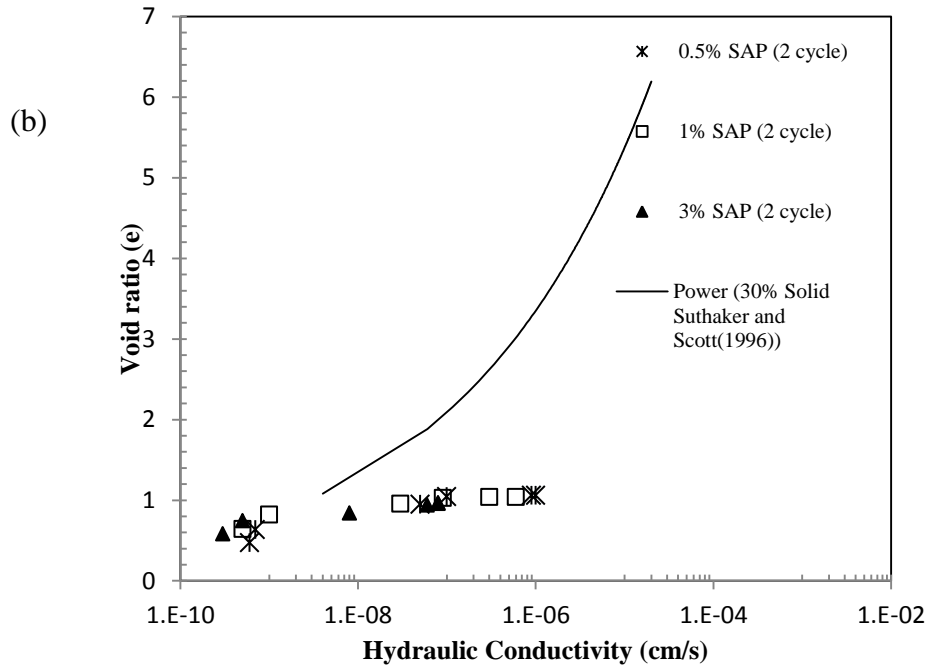

**Fig. 4.11** Hydraulic conductivity test results for MFT dewatered by SAPs and (a) One cycle of freeze/thaw (b) Two cycles of freeze/thaw

#### 4.4 Summary and conclusion

The consolidation behavior and hydraulic conductivity of oil sands MFT dewatered by using SAP alone or SAP combined with freeze/thaw cycle(s) are investigated. Based on the results of large strain consolidation testing, the compressibility characteristics of the dewatered MFT are determined and compared to those obtained by Suthaker and Scott (1994) and Proskin et al. (2010) on MFT that had not been dewatered. MFT dewatered with SAP sachets have significantly lower initial void ratios. The dewatering of MFT by using SAP and the freeze/thaw process decreases the initial void ratio by factors of 3 and 1.4, respectively. The data suggest that as the solid content decreases, the compressibility increases.

A constant head hydraulic conductivity test has been conducted on dewatered MFT after each stage of incremental loading and the data are compared to those from Suthaker and Scott (1996) which were obtained on MFT that were not dewatered. The results indicate that as the void ratio decreases, the hydraulic conductivity decreases as well. Samples that are dewatered by the freeze/thaw process and the use of SAP show higher hydraulic conductivities in low effective stresses compared to samples that are solely dewatered by using SAP. The higher permeability is

a result of the ice network within the MFT created during freezing which remain as interconnected voids after thawing.

SAP regeneration techniques and their effect on the compressibility and permeability of MFT are investigated. The temperature induced method is examined. Consolidation and hydraulic conductivity testing are conducted on MFT that are dewatered with SAP which had undergone five cycles of regeneration. The results suggest that the lower absorption capacity of regenerated SAP will result in higher void ratios, lower compressibility and higher hydraulic conductivity under low effective stresses.

#### **4.5 Acknowledgment**

The authors would like to acknowledge the technical laboratory assistance provided by Jean Claude Célestin and Dr. Julio Angel Infante Sedano of the Department of Civil Engineering, University of Ottawa.

## 4.6 Reference

- Alamgir A., Harbottle D., Masliyah J. and Xu Z. (2012). "Al-PAM assisted filtration system for abatement of mature fine tailings.", *Chemical Engineering Science*, 80(1), 91–99.
- Bakass M., Bellat J.P. and Bertrand G. (2007). "Characterization of a superabsorbent polymer." *Journal of Applied Polymer Science*, 104 (2), 782-786.
- Bakass M., Bellat J.P. and Bertrand G. (2006). "The adsorption of water vapor on super absorbent product at low temperatures and low mass." *Journal of Applied Polymer Science*, 100 (2), 1450-1456.
- Barbour S.L. and Wilson G.W. (1993). "Evaluation of the saturated-unsaturated groundwater conditions of a thickened tailings deposit." *Canadian Geotechnical Journal*, 30 (6), 935-946.
- BGC Engineering Inc. (2010). OSRIN Report No. TR-1. "Oil Sands Tailings Technology Review." Oil sands research and information network, University of Alberta, School of Energy and the Environment, Edmonton, Alberta.
- Caughill D.L., Morgensten N.R., and Scott J.D. (1993). "Geotechnics of nonsegregating oil sand tailings." *Canadian Geotechnical Journal*, 30 (5), 801-811.
- Chalaturnyk R J, Don Scott J. and Ozum B. (2002). "Management of oil sand tailings." *Journal of petroleum science and technology*, 20 (9), 10251046.
- Chatterjee P.K. and Gupta B.S. (2002). "Measurement techniques for absorbent material and products." *Textile Science and Technology*, 13, 389-406.
- Dawson, R. F., Segó, D. C., & Pollock, G. W. (1999). "Freeze/thaw dewatering of oil sands fine tails." *Canadian Geotechnical Journal*, 36(4), 587-598.
- Dzinomwa G. P. T., Wood C. J. and Hill D. J. T. (1997). "Fine coal dewatering using pH- and temperature-sensitive superabsorbent polymers". *Polymers for Advanced Technologies journal*, 8 (12), 767-772.
- ERCB. (2009). "Tailings performance criteria and requirements for oil sands mining schemes." Directive 074, Alberta Energy Resources Conservation Board, Calgary, Alberta, Canada.
- Farkish, A., Fall, M., (2013). SAP based rapid dewatering of oil sands mature fine tailings. *Minerals Engineering* (submitted).

- Guo, Y. (2012). "Electro kinetic dewatering of oil sands tailings." Master thesis, University of Western Ontario London, Ontario, Canada.
- Hocking, M.B. and Lee, G.W. (1977). "Effect of chemical agents on settling rates of sludge from effluent of hot-water extraction of Athabasca oil sands." *Fuel journal*, 56 (3), 325-333.
- Houlihan R.H, Mian M.H. and Lord E.R. (2010). "Oil sands tailings –technology developments and regulations", ISBN 978-0-9806-0-1.
- Johnson R.L., Bork P., Alen E.A.D., James W.H. and Kovernly L. (1993), "Oil sands sludge dewatering." Alberta conservation and reclamation council, RRTAC 93-8.
- Kasperski, K.L. (1992). "A review of properties and treatment of oil sands tailings." *AOSTRA Journal of Research*, 8 (1), 11–53.
- Mikula R.J., Kasperski K.L, Burns R.D, and MacKinnon M D. (1996). "Nature and fate of oil sands fine tailings." *American Chemical Society*, 251 (14), 677-723.
- Miller, W. G, Scott, J. D., & Segó, D. C. (2010). "Influence of the extraction process on the characteristics of oil sands fine tailings." *CIM Journal*, 1(2), 93-112.
- Miller, W. G. (2010). "Comparison of geoenvironmental properties of caustic and noncaustic oil sand fine tailings." Ph.D. thesis, University of Alberta, Edmonton, AB.
- Pollock, W. G. (1988). "Large strain consolidation of oil sands tailings sludge.", M.A.Sc. thesis, University of Alberta, Edmonton, AB.
- Proskin S., Segó D., Alostaz M. (2010). "Freeze–thaw and consolidation tests on Suncor mature fine tailings (MFT)." *Journal Cold Regions Science and Technology*, 63(3), 110-120.
- Rosa, F. and Casquilho, M. (2012). "Effect of synthesis parameters and of temperature of swelling on water absorption by a superabsorbent polymer." *Fuel Processing Technology*, 103, 174–177
- Sadeghi M. and Hosseinzadeh H. (2008). "Synthesis and Swelling Behavior of Starch-Poly(Sodium Acrylate-co-Acrylamide) Superabsorbent Hydrogel" ,*Turk J Chem.*, 32 (3), 375- 388.
- Sathaker, N.N. and Scott, J.D. (1996). "Measurement of hydraulic conductivity in oil sand tailings slurries." *Canadian geotechnical journal*, 33(4), 642-653

- Scott, J.D., Dusseault, M.B. and Carrier, W.D, "Large scale self-weight consolidation testing Consolidation of Soils: Testing and Evaluation : a Symposium." in consolidation of soils testing and evaluation, Yong, R. N. , Townsend, F. C, Issue 892, 1986, 500-514
- Silva M.J., Biggar K.W. and Jacobsz S.W. (1999). "Plant Dewatering and strengthening of tailing: Laboratory and computer simulation." In Tailing and waste management, , A.A Balkema, Netherland, 315-322.
- Staples T. L., Chatterjee P. K. (2002). "Synthetic superabsorbents." In Absorbent Technology., 383-318
- Suthaker, N.N. (1995). "Geotechnics of oil sand fine tailings." Ph.D. thesis, University of Alberta, Edmonton, AB.
- Suthaker, N.N. and Scott, J.D.(1994). "Consolidation testing of oil sand fine tails." Proceedings, International Land Reclamation and Mine Drainage Conference and the Third International Conference on the Abatement of Acidic Drainage, Pittsburgh, PA, 4, pp. 399–406.
- Zohuriaan-Mehr M.J and Kabiri K. (2008,). "Superabsorbent polymer materials: A Review." Iranian Polymer Journal, 17 (6), 451477.

## Chapter 5

### Summary, conclusions & recommendations

#### 5.1 Summary

Oil sands MFT have been dewatered by using a SAP, and over 100 samples are used to determine the solid content, undrained vane shear strength, consolidation rate and hydraulic conductivity of MFT. The effect of the freeze/thaw process is also investigated for each one of the mentioned variables. Two types of SAP based dewatering methods are used in this thesis. The first method is called the direct method in this study, which consists of directly mixing a known weight of SAP with a known weight of MFT in a large container until a homogenous mixture is obtained. The second method is called the indirect method in the present study, which consists of placing sachets filled with various amounts of SAP (SAP sachets) into containers that contain MFT slurries. The MFT slurries are mixed with the SAP sachets by using a mixer for 10 minutes every day during the first four days, and then left to rest for the next three days. Various SAP proportions are used to prepare the mixtures: 0%, 0.5%, 1% and 3%. The undisturbed cylindrical samples are taken at different time intervals (1, 8, 24, 72 and 168 hours for direct method - 7 days and 14 days for indirect method) and subjected to vane shear testing.

To investigate the permeability and compressibility behaviors of the material in question, hydraulic conductivity and consolidation tests are conducted. The procedures involve the consolidating of specimens with incremental loading and directly measuring the hydraulic conductivity by using a constant head hydraulic conductivity test. The results illustrate changes in the void ratios as effective stress and permeability vary.

In addition, two different methods of SAP regeneration (pH induced and temperature induced regeneration) are investigated. The effects of using regenerated SAP on solid content, shear strength, consolidation rate and permeability of MFT have been determined.

## 5.2 Conclusions

The following conclusions can be drawn from the investigations carried out in this thesis.

1. Rapid and significant dewatering as well as increase in undrained shear strength and solid content of MFT can be achieved by using the proposed dewatering and densification methods (direct or indirect) for SAP. Better performance with regard to dewatering and increase in strength is obtained with the indirect method.
2. Freeze/thaw cycles can significantly increase the strength and solid content of MFT that have been dewatered with SAP. This is beneficial for the reduction of dewatering costs, as the required percentage of SAP will be reduced.
3. SAPs that have been regenerated through light thermal drying are also capable of dewatering, and thus increase the strength and solid content of MFT in a significant manner.
4. A higher strength of MFT when treated with SAP should be expected in the field, since the samples tested have not been subjected to evaporation.
5. The dewatering of MFT by using a SAP and the freeze/thaw process decrease the initial void ratio by factors of 3 and 1.4, respectively. Also, the data suggest that as the solid content decreases, the compressibility increases.
6. The results of the constant head hydraulic conductivity test indicate that as the void ratio decreases, the hydraulic conductivity decreases as well. Samples that are dewatered by the freeze/thaw process show higher hydraulic conductivities in low effective stresses compared to samples that are solely dewatered by SAPs. The higher permeability is a result of the ice network within the MFT which was created during freezing and remains as interconnected voids after thawing.
7. Temperature induced SAP recycling has been determined to be more efficient due to higher absorption capacity and lower energy consumption.
8. The lower absorption capacity of regenerated SAP results in higher void ratios, lower compressibility and higher hydraulic conductivities in low effective stresses.
9. The results indicate that a dewatering and densification method that uses SAPs is a promising approach to increase the speed of the dewatering and consolidation processing

of MFT, thus increasing the pace of reclamation and reducing the environmental footprint of heavy oil operations in Canada.

## **5.2 Recommendations**

The following recommendations are suggested.

1. A field scale investigation on the dewatering of MFT with SAP can be conducted to evaluate the ability to apply the laboratory results in the field. The mixing procedure of MFT and SAP sachets, amount of SAP used and curing time, would be dependent on the scale of testing; therefore, more accurate results and estimations of the required time, energy and expenses are required. In the author's opinion, valuable results can be obtained and a greater understanding of the super absorbent behavior of fine tailings will be achieved when a large scale investigation is carried out.
2. Several other dewatering methods can be introduced and tested which can be combined with the methods used in this study to improve the results. Different sets of disposal packages, including SAP dewatering, can be designed and based on the obtained results so that an optimized package would be achieved.
3. Polymer regeneration is considered as a significant advantage for dewatering. Therefore, more research should be done on finding new regeneration methods that allows SAPs to retain higher absorption capacities after several reuse cycles.
4. The pore structure and microstructure of MFT should be explored in more detail and the effect of SAP on the pore structure of slurry can be evaluated.
5. More studies need to be carried out on thixotropic gel strength and its effect on consolidation behavior which can be very beneficial to understanding the long term consolidation behavior of MFT in tailings ponds.
6. The obtained data can be used to model the consolidation and permeability of dewatered MFT in tailings ponds.

**Appendix A**  
**Thesis Figures**

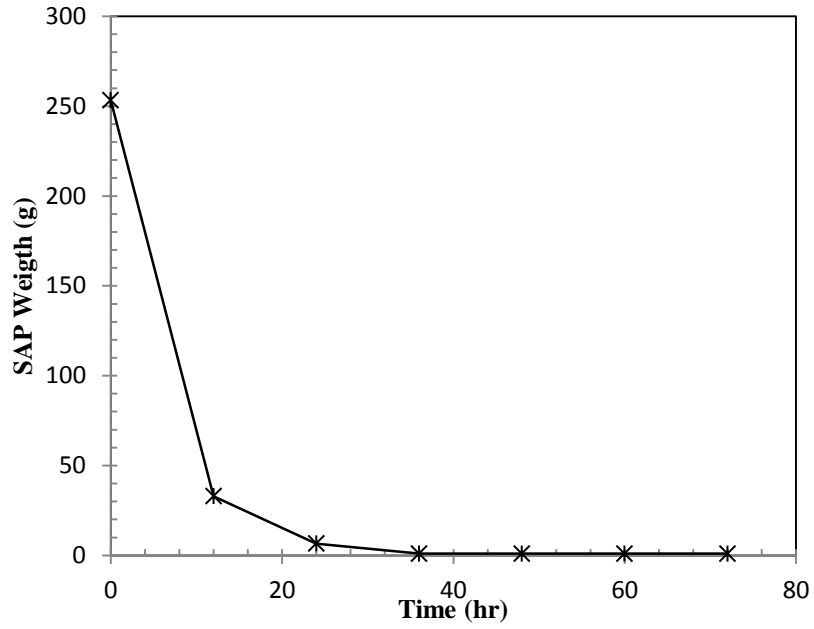

**Fig. A.1** Weight change of SAP in the oven during temperature induced regeneration (Distilled water)

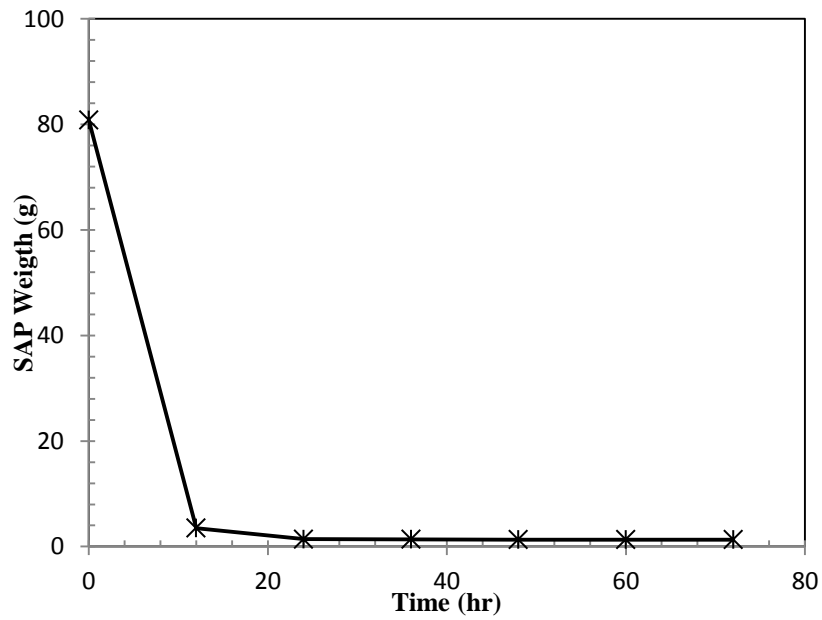

**Fig. A.2** Weight change of SAP in the oven during temperature induced regeneration (MFT water)

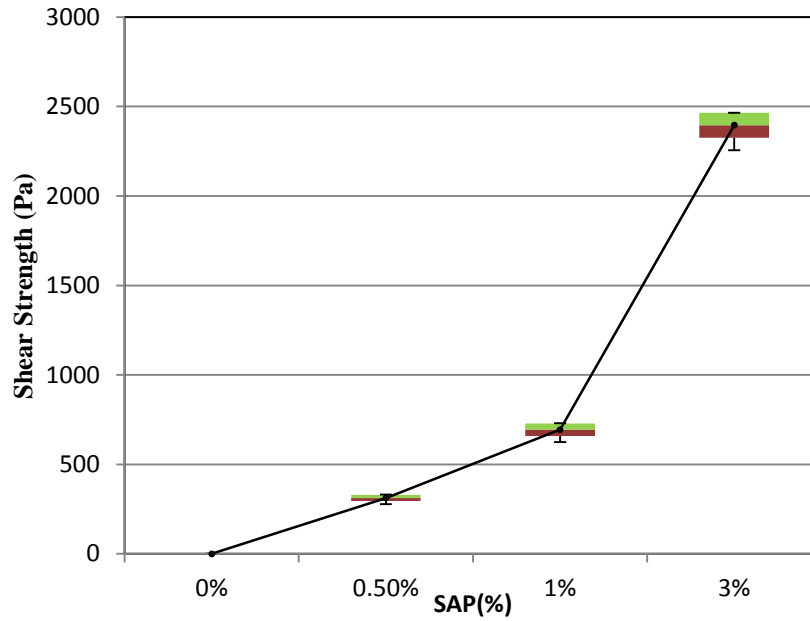

**Fig. A.3** Results of undrained vane shear testing of MFT treated with SAP after 1 hour  
(direct method)

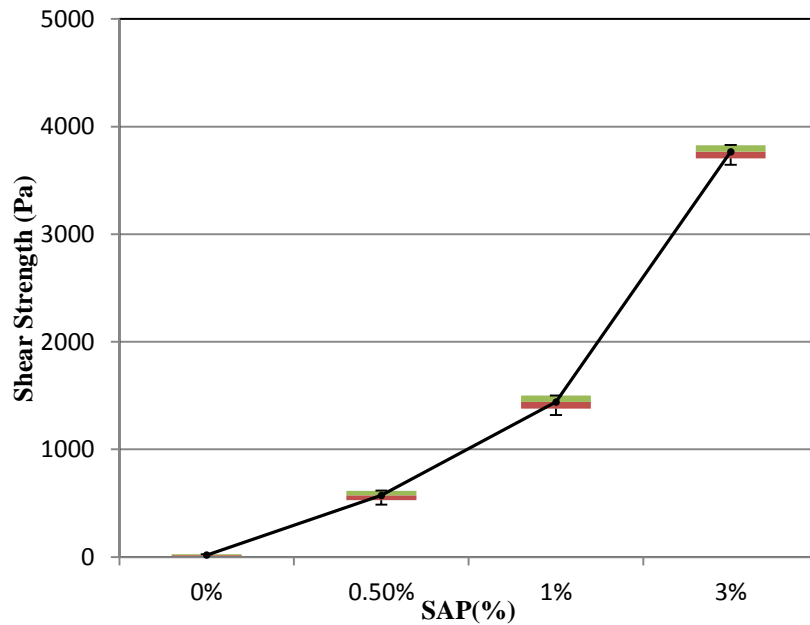

**Fig. A.4** Results of undrained vane shear test of MFT treated with SAP after 8 hours  
(direct method)

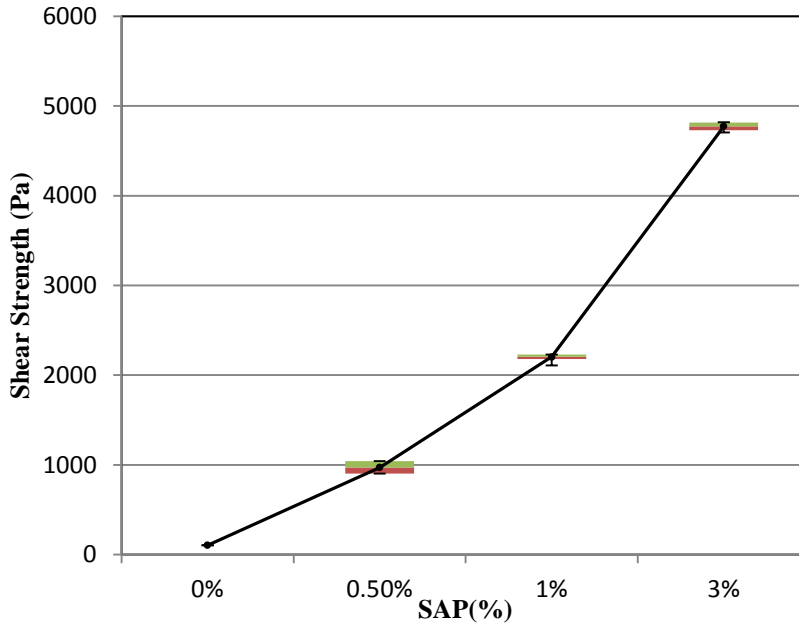

**Fig. A.5** Results of undrained vane shear test of MFT treated with SAP after 24 hours (direct method)

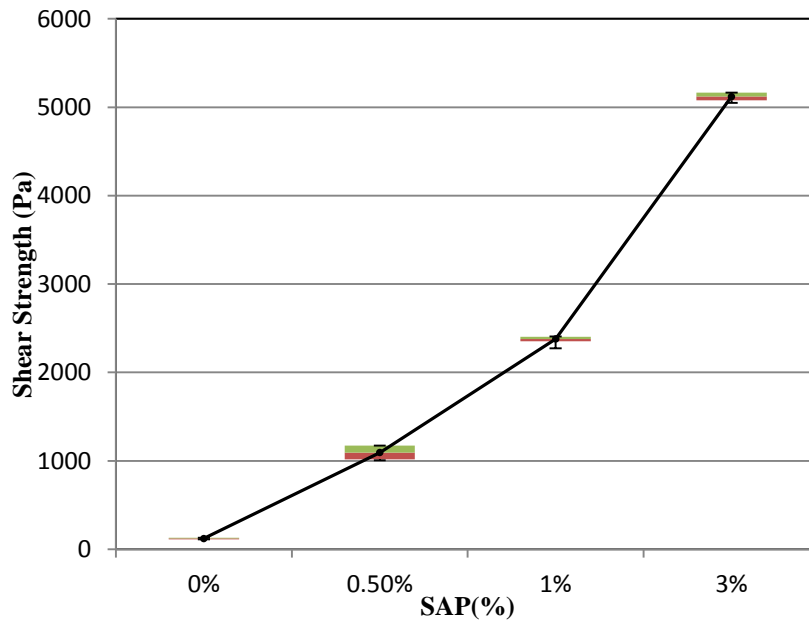

**Fig. A.6** Results of undrained vane shear test of MFT treated with SAP after 72 hours (direct method)

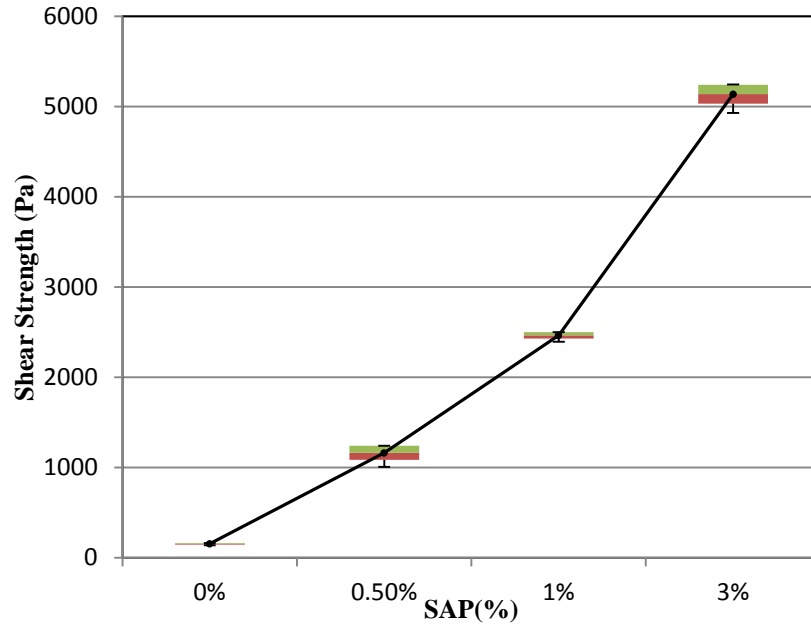

**Fig. A.7** Results of undrained vane shear test of MFT treated with SAP after 168 hours (direct method)

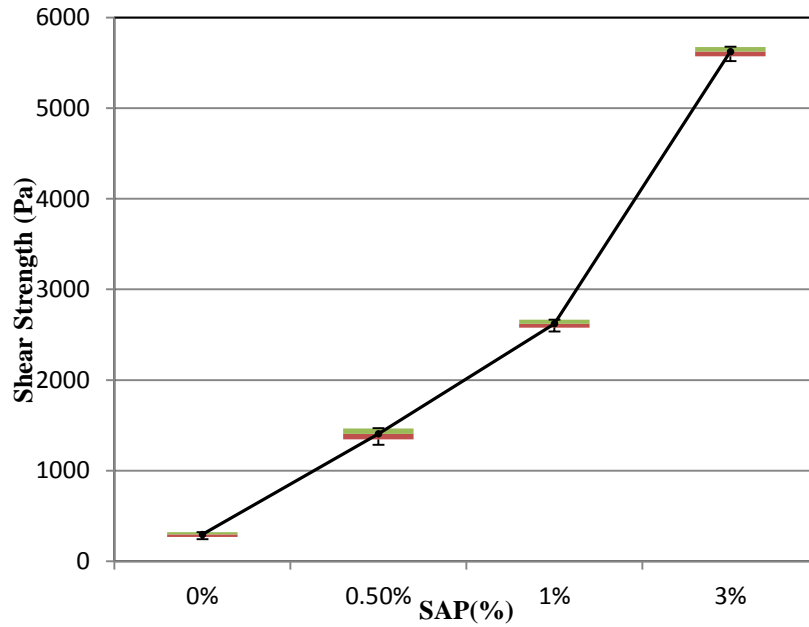

**Fig. A.8** Results of undrained vane shear test of MFT treated with SAP for 24 hours and 1 cycle of freeze/thaw (direct method)

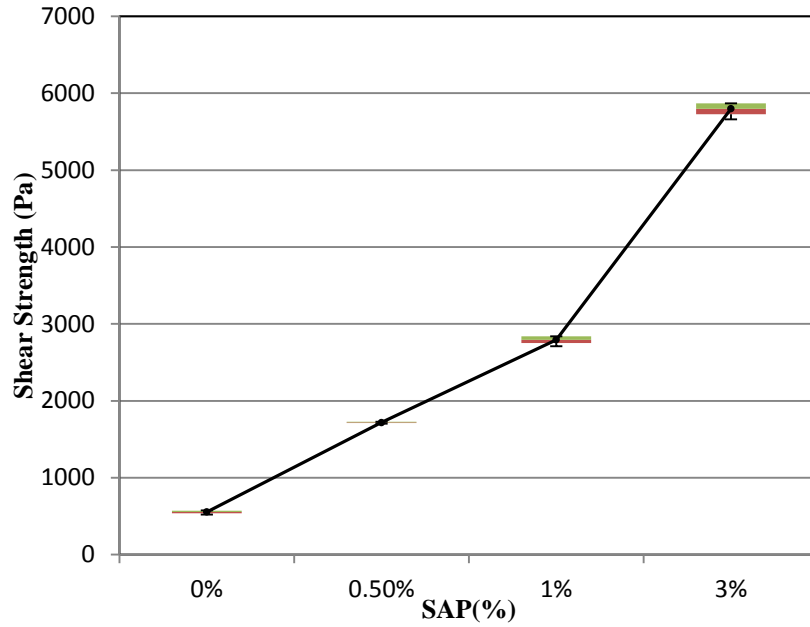

**Fig. A.9** Results of undrained vane shear test of MFT treated with SAP for 24 hours and 2 cycles of freeze/thaw (direct method)

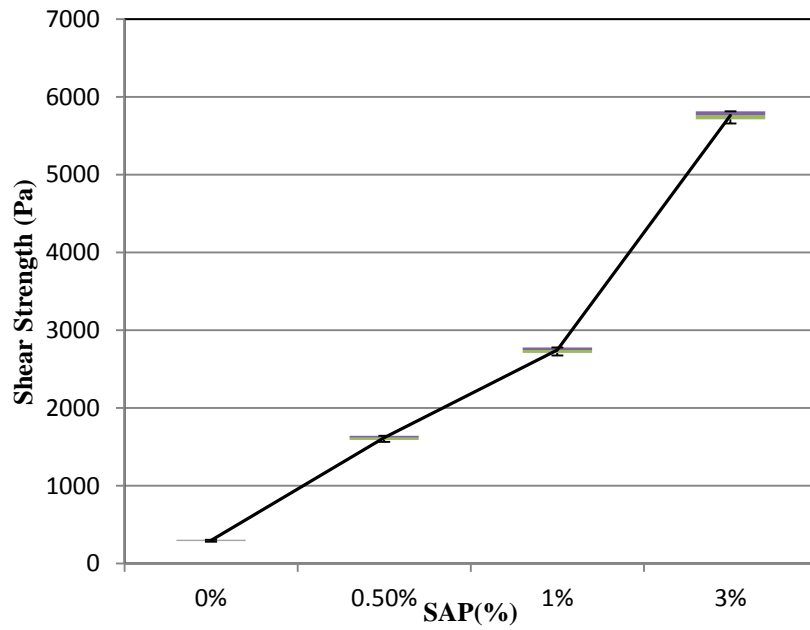

**Fig. A.10** Results of undrained vane shear test of MFT treated with SAP for 76 hours and 1 cycle of freeze/thaw (direct method)

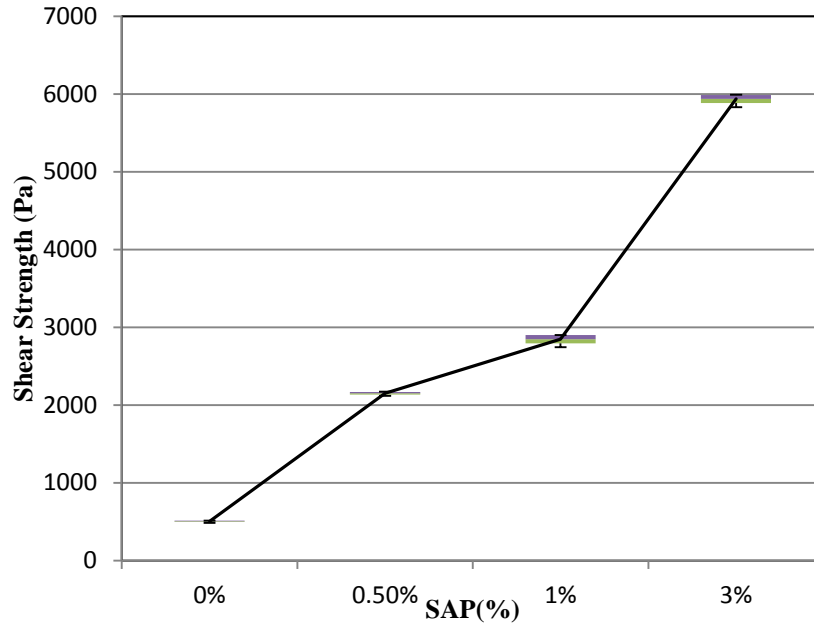

**Fig. A.10** Results of undrained vane shear test of MFT treated with SAP for 76 hours and 2 cycles of freeze/thaw (direct method)

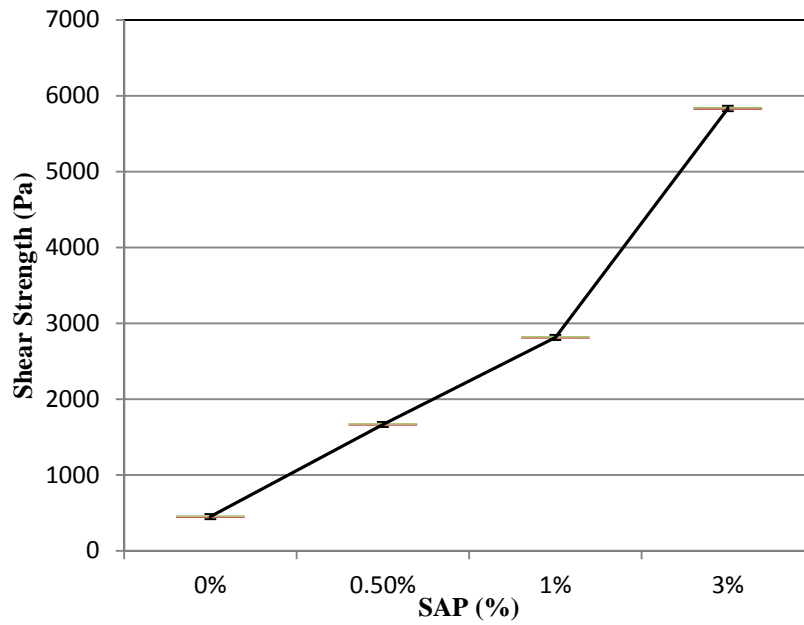

**Fig. A.11** Results of undrained vane shear test of MFT treated with SAP for 168 hours and 1 cycle of freeze/thaw (direct method)

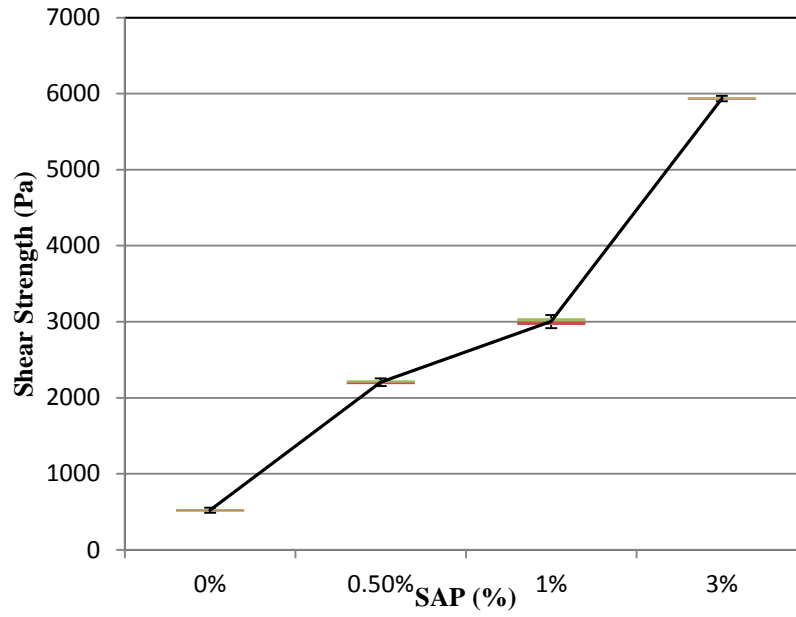

**Fig. A.11** Results of undrained vane shear test of MFT treated with SAP for 168 hours and 2 cycles of freeze/thaw (direct method)

## **Appendix B**

### **Photos from the study**



**Photo A.1** Mixing SAP with MFT (direct method)

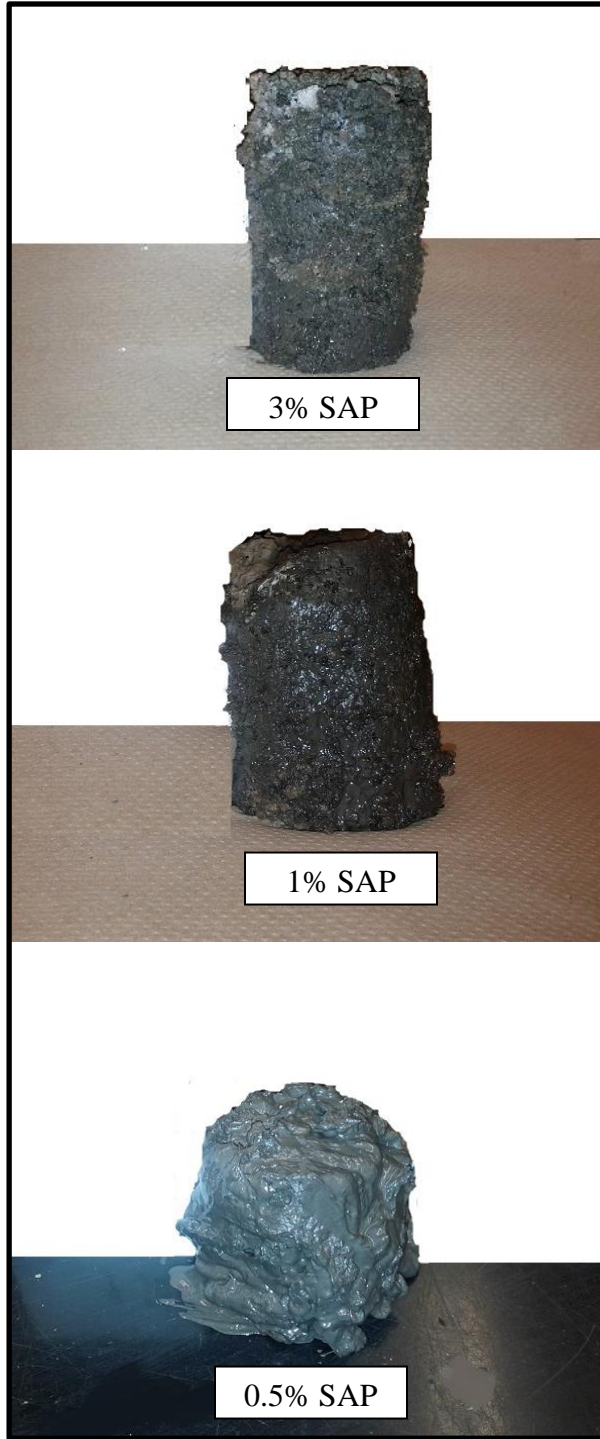

**Photo A.2** MFT treated with SAP by using direct method



**Photo A.3** SAP sachets



**Photo A.4** Mixer used in the indirect method

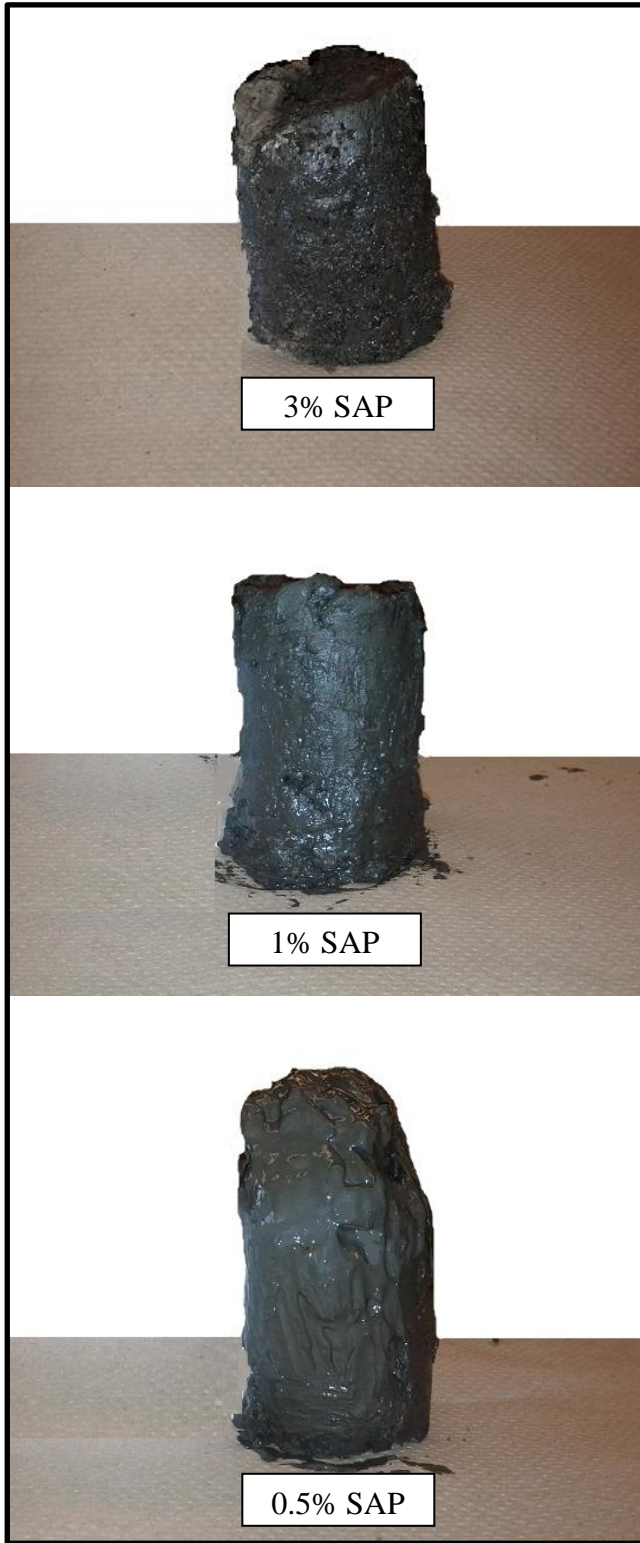

**Photo A.5** MFT treated with SAP by using indirect method

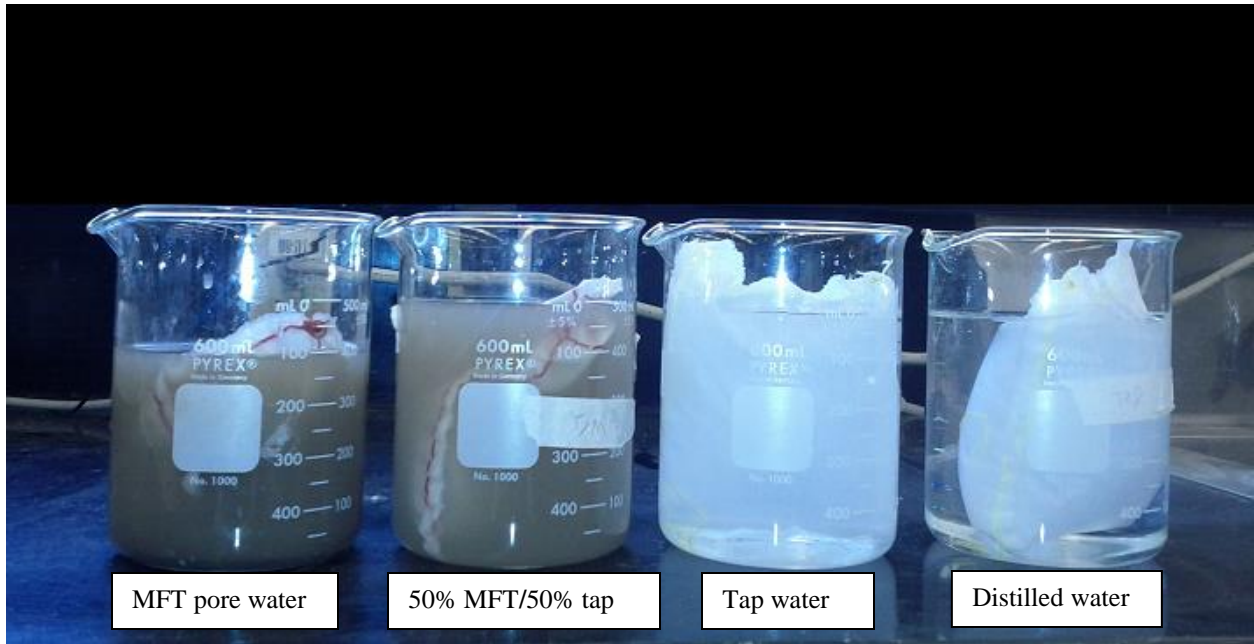

**Photo A.6** Determining SAP absorption capacity

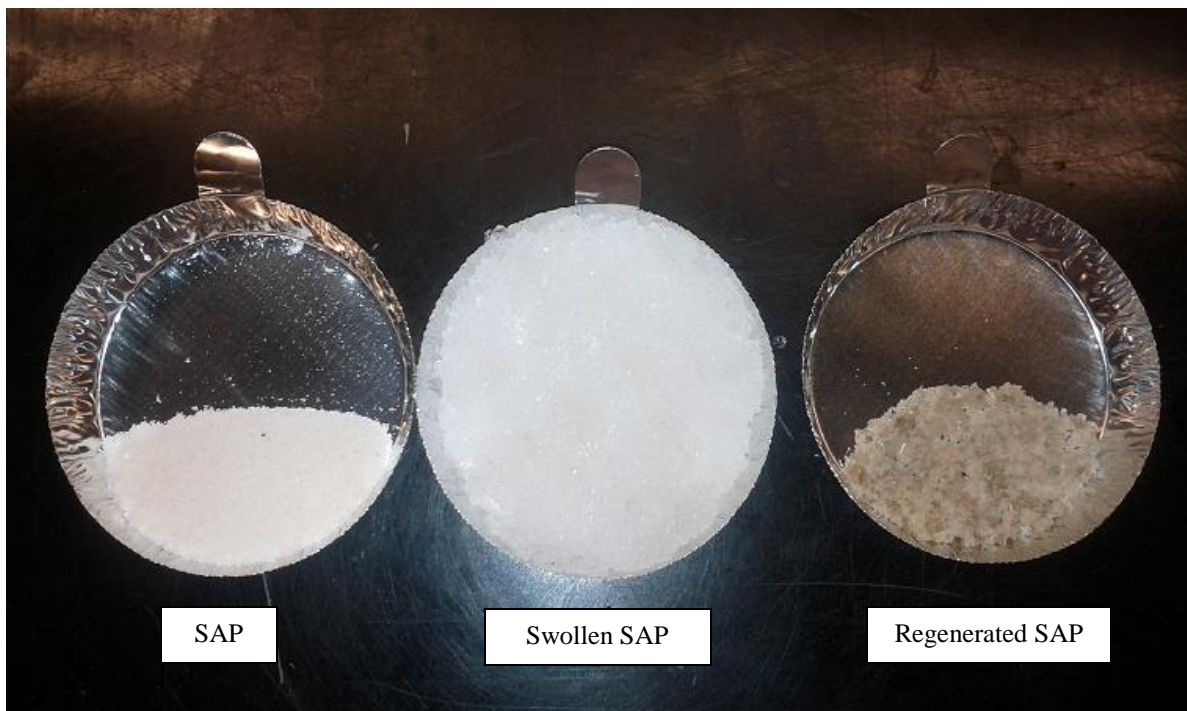

**Photo A.7** Temperature induced regeneration



**Photo A.8** Swelling of temperature regenerated SAP



**Photo A.9** Consolidation and permeability apparatus



**Photo A.10** Vane shear apparatus