

**Regulation of IL-12, IL-23, IL-27 in Response
to IFN- γ /LPS
in Human Monocytes and Macrophages**

Maria Andreea Blahoianu

Thesis submitted to the faculty of Graduate and Postdoctoral Studies
In partial fulfillment of the requirements
For the Doctorate in Philosophy degree in Microbiology and Immunology

Microbiology and Immunology
Faculty of Medicine
University of Ottawa

©Maria Andreea Blahoianu, Ottawa, Canada, 2013

Table of Contents

Dedication	5
Acknowledgements	6
List of Abbreviations	7
List of Figures	11
Abstract	15
<u>Chapter 1 Introduction</u>	17
Monocytes and Macrophages	20
IL-12 cytokine.	21
IL-12 family of cytokine	21
IL-23 and its biological properties	23
IL-27 and its biological properties	25
Inducers of IL-12 family	28
IFN- γ and the JAK/STAT signaling pathway	28
IFN- γ -mediated expression of the IL-12 cytokine family	32
IFN- γ primes cells for heightened responses to LPS	32
Toll-like receptor (TLR) signaling	34
LPS signaling pathways	34
Mitogen-Activated Protein Kinase (MAPK) cascade	35
Phosphatidylinositol-3-kinase (PI3K) signaling pathway	41
Signaling pathways involved in IL-23 regulation	42
Signaling pathways involved in IL-27 regulation	44
Interaction between the MAPK and PI3K signaling pathways	45
Rationale	48
Hypothesis	50
Objectives	50
<u>Chapter 2 Materials and Methods</u>	51
Isolation of monocytes, cell culture and reagents	51
Cell stimulation and collection of supernatants.	53
Reverse-transcription polymerase chain reaction (RT-PCR)	54
Measurements of mRNA by relative quantitative real-time PCR	55
Quantification of IL-23, IL-27 and IL-12/23p40 proteins by ELISA	56
Western blot analysis	57
Cell surface staining of TLR4 and IFNGR1 by flow cytometry	58
Neutralization assay of IFNGR1/CD119	59
Transfection of small interfering RNA (siRNA)	59
Statistical analysis	60

Chapter 3 Regulation of IFN- γ and LPS-induced IL-23 in myeloid cells 61

3.1 IFN- γ -induced IL-23 production and its regulation in primary human monocytes ..61

IFN- γ induces the expression of IL-12p40 and IL-23 in positively selected but not in negatively selected human monocytes 62

The JAK/STAT pathway negatively regulates IL-12/23p40 protein and IL-23p19 mRNA expression but not IL-23 expression following IFN- γ stimulation 70

IL-23 expression in IFN- γ -stimulated monocytes is negatively regulated by the PI3K pathway..... 73

IL-23 expression in IFN- γ -stimulated monocytes is positively regulated by p38 and negatively regulated by the JNK MAPK pathways 78

Role of calcium signaling in IFN- γ -induced IL-23 expression 83

3.2 LPS-induced IL-23 production and its regulation in THP-1 promonocytic cells 88

IFN- γ /LPS induces the expression of IL-12/23p40 and IL-23 production in THP-1 cells 89

LPS-induced IL-23 production is regulated by p38 and JNK MAPKs 89

Role of the PI3K signaling in LPS-induced IL-23 expression 99

3.3 IFN- γ /LPS-induced IL-23 production and its regulation in human monocyte-derived macrophages 107

Generation and characterization of MDMs 107

IFN- γ /LPS and LPS alone induce IL-12/23p40 and IL-23 production in human MDMs 108

IL-12p40/23 expression in LPS- and IFN- γ /LPS-stimulated macrophages is not regulated by the MAPK pathways 108

IL-12p40/23 expression in LPS- and IFN- γ /LPS-stimulated macrophages is not regulated by the PI3K pathway..... 113

IL-12p40/23 expression in LPS- and IFN- γ /LPS-stimulated macrophages is not regulated by the JAK/STAT pathway..... 118

Chapter 4 Regulation of IFN- γ and LPS-induced IL-27 in myeloid cells 134

4.1 IFN- γ -induced IL-27 and IL-27p28 expression are differentially regulated through JNK MAPK and PI3K pathways, independent of JAK/STAT in human monocytic cells.....134

IFN- γ induces IL-27 production in primary human monocytes 135

IFN- γ -induced IL-27 production is not regulated by the JAK/STAT signaling pathway 140

IFN- γ -induced IL-27 protein production is positively regulated by JNK MAPK in monocytic cells 143

IFN- γ -induced IL-27 protein production is positively regulated through PI3K in human monocytes 144

4.2 IFN- γ -induced IL-27 and IL-27p28 expression are differentially regulated through JNK, p38 MAPK and PI3K pathways in THP-1 cells and MDMs 156

LPS and IFN- γ /LPS induce IL-27 production in THP-1 cells and MDMs	158
IFN- γ /LPS-induced IL-27 production is positively regulated through JNK and p38 MAPK signaling pathway in THP-1 cells and MDMs	163
Role of the PI3K signaling pathway in IFN- γ /LPS-induced IL-27 expression	177
Role of JAK/STAT signaling pathways in IFN- γ /LPS-induced IL-27 expression	184
<u>Chapter 5 mRNA-protein inconsistency in response to IFN-γ/LPS in human MDMs.</u>	190
Proteosomal and lysosomal degradation	190
Role of tristetraprolin.....	193
Role of IL-27 receptor recycling	198
<u>Chapter 6 Discussion.....</u>	208
Regulation of IL-23 production in human myeloid cells	209
Regulation of IFN- γ -induced IL-23 production in human monocytic cells	209
Regulation of LPS-induced IL-23 production in THP-1 cells and MDMs	216
Regulation of IL-27 production in human myeloid cells	221
Regulation of IFN- γ -induced IL-27 production in human monocytic cells	221
Regulation of IFN- γ /LPS-induced IL-27 production in THP-1 cells and MDMs.....	227
mRNA-protein discontinuity in response to IFN- γ /LPS in human MDMs	233
Concluding remarks and future directions.....	236
Contribution of Collaborators	244
References	245

Dedication

To my grandparents, Nicolae Mândreanu and Ana Ursu, whose courage and grace have been an inspiration.

Acknowledgements

First and foremost, I would like to acknowledge my supervisor, Dr. Ashok Kumar for his constant guidance and mentorship. His support from the beginning until the end of my thesis has been invaluable. It has been an absolute pleasure to work in his laboratory.

I would also like to thank my co-supervisor Dr. Angel and my thesis committee members Dr. Paul Macpherson and Dr. Lionel Filion for their invaluable advice and support throughout my graduate studies.

My lab mates Dr. Katrina Gee, Aurelia Busca, Mansi Saxena, Shifawn O'Hara, Danylo Sirskyj, Sunita Pandey, Niranjala Gajanayaka, Yulia Konaski, Jay Majithia, Kanish Mohib, Seghen Woldai, Salma Iqbal, Dr. Ali Rahim Rahimi for their friendship and kindness. I was very blessed to work in such a supportive environment.

I would like to thank my sister, and my parents, Rodica and Andrei Blahoianu for imparting on me very early on the importance of a good education.

To my husband and best friend Curtis Shillington for his unconditional love and support.

Finally, to my son, David for always making me laugh and feel blessed.

List of Abbreviations

Akt – Protein kinase B

AP-1 – Activator Protein-1

APC – Antigen-presenting cell

ATP – Adenosine Triphosphate

B cells – B lymphocyte cells

BSA – Bovine serum albumin

CD – Cluster of differentiation

cDNA – complementary deoxyribonucleic acid

cIAP – cellular inhibitor of apoptosis

CTL – Cytotoxic T-lymphocyte

DC – Dendritic cells

EAE – Experimental autoimmune encephalitis

EBI3 – Epstein Barr Virus-induced gene 3

ELISA – Enzyme linked immunosorbant assay

ERK – Extracellular signal-regulated kinase

FBS – Fetal bovine serum

GATA-3 – GATA-binding protein 3

gp130 – Glycoprotein 130

HIV – Human Immunodeficiency Virus

HRP – Horse radish peroxidase

ICAM – Intracellular adhesion molecule

IFIG – Interferon-inducible genes

IFN- γ – Interferon gamma
IFNR – Interferon receptor
IL – Interleukin
IL-1R – IL-1 receptor
IL-12R – IL-12 receptor
IL-23R – IL-23 receptor
IL-27R – IL-27 receptor
IRAK – IL-1R-associated kinases
IRF – Interferon regulator factor
JAK – Janus kinase
JNK – c-Jun N-terminal kinase
LPS - Lipopolysaccharide
MAPK – Mitogen activated protein kinase
M-CSF – Macrophages colony-stimulating factor
MD2 – Myeloid differentiation protein 2
MDM – Monocyte-derived macrophages
MEK – Mitogen-activated kinase kinase
MHC – Major histocompatibility complex
MKK – Mitogen-activated kinase kinase
mRNA – Messenger ribonucleic acid
MS – Multiple sclerosis
mTOR – Mammalian target of rapamycin
MyD88 – Myeloid differentiation primary response gene 88
NF- κ B – Nuclear factor-kappa B

NK cells – Natural killer cells

PAMP – Pathogen-associated molecular pattern

PBMC – Peripheral blood mononuclear cell

PBS – Phosphate buffered saline

PE – Phycoerythrin

PerCP – Peridinin chlorophyll protein

PI3K – Phosphoinositide-3-kinase

PMA – Phorbol-12-myristate-13-acetate

q-RT-PCR – Semi-quantitative real time polymerase chain reaction

SAPK – Stress-activated protein kinase

siRNA – small interfering RNA

STAT – Signal Transducer and activator of transcription

T cells – T lymphocyte cells

TAB – TAK-binding protein

TAK-1 – TCF- β -activated kinase 1

TCCR – T-cell cytokine receptor

Th – T-helper

Th17 – T-helper 17

TIR – TLR/IL-1 homology

TLR – Toll-like receptor

TGF – Transforming growth factor

TMB – 3,3',5,5'-tetramethylbenzidine

TMEV – Theiler's murine encephalomyelitis virus

TNF – Tumor necrosis factor

TRAF – TNF-associated factor

TRIF – TIR-domain-containing adapter-inducing IFN- β

List of Figures

- Figure 1** The IL-12 cytokine family and its receptors. (Page 18)
- Figure 2** The signaling pathway of Interferon (IFN- γ) and its receptor. (Page 30)
- Figure 3** Structure of LPS. (Page 36)
- Figure 4** LPS stimulation activates a variety of signaling pathways and transcription factors. (Page 38)
- Fig. 3.1.1** IFN- γ induces IL-23 and IL-12p40 expression in positively selected human monocytes. (Page 63)
- Fig. 3.1.2** IFN- γ stimulation of CD14-activated monocytes triggers IL-12p40 and IL-23 production. (Page 65)
- Fig. 3.1.3** CD14 engagement sensitizes positively selected monocytes to IFN- γ stimulation by upregulating IFNGR1. (Page 68)
- Fig. 3.1.4** Upregulated IFNGR1 on positively selected monocytes exhibit enhanced TLR-4 receptors following IFN- γ stimulation leading subsequently to enhanced LPS-induced IL-23 production. (Page 71)
- Fig. 3.1.5** IFN- γ -induced IL-12p40 and IL-23 expression is negatively regulated by the JAK/STAT pathway. (Page 74)
- Fig. 3.1.6** IFN- γ -induced IL-23 expression is negatively regulated by the PI3K pathway. (Page 76)
- Fig. 3.1.7** IFN- γ activates ERK, JNK and p38 MAPKs. (Page 79)
- Fig. 3.1.8** IFN- γ -induced IL-12p40 and IL-23 expression is positively regulated by p38 MAPK and negatively regulated by the JNK MAPK pathway. (Page 81)
- Fig. 3.1.9** SP600125, a JNK MAPK inhibitor, does not induce IL-23 production. (Page 84)
- Fig. 3.1.10** IFN- γ -induced IL-12p40 and IL-23 expression is not regulated by the calcium signaling pathway. (Page 86)
- Fig. 3.2.1** LPS induces IL-23p19 mRNA expression, IL-23 and IL-12/23p40 protein production. (Page 90)
- Fig. 3.2.2** Inhibition of LPS-induced ERK, JNK and p38 phosphorylation in THP-1 cells. (Page 93)
- Fig. 3.2.3** LPS-induced IL-23 production is positively regulated through JNK and p38 MAPK signaling pathways. (Page 95)
- Fig. 3.2.4** JNK MAPK siRNA down-regulates LPS-induced IL-23 expression. (Page 97)
- Fig. 3.2.5** p38 MAPK siRNA down-regulates LPS-induced IL-23 expression. (Page 100)
- Fig. 3.2.6** LPS-induced IL-23 production is positively regulated through PI3K signaling pathways in THP-1 cells. (Page 102)
- Fig. 3.2.7** PI3K siRNA down-regulates LPS-induced IL-23 expression. (Page 105)
- Fig 3.3.1** Monocyte-derived macrophage characterization. (Page 109)
- Fig. 3.3.2** LPS and IFN- γ /LPS induce IL-23 expression in monocyte-derived macrophages. (Page 111)

Fig. 3.3.3 IFN- γ /LPS-induced IL-23 production is not regulated through the JNK MAPK pathway in human MDMs. (Page 114)

Fig. 3.3.4 LPS-induced IL-23 production is not regulated through the JNK MAPK pathway in human MDMs. (Page 116)

Fig. 3.3.5 IFN- γ /LPS-induced IL-23 production is not regulated through the p38 MAPK pathway in human MDMs. (Page 120)

Fig. 3.3.6 LPS-induced IL-23 production is not regulated through the p38 MAPK pathway in human MDMs. (Page 122)

Fig. 3.3.7 IFN- γ /LPS-induced IL-23 production is not regulated through the ERK MAPK pathway in human MDMs. (Page 124)

Fig. 3.3.8 LPS-induced IL-23 production is not regulated through the ERK MAPK pathway in human MDMs. (Page 126)

Fig. 3.3.9 IFN- γ /LPS-induced IL-23 production is not regulated through the PI3K pathway in human MDMs. (Page 128)

Fig. 3.3.10 LPS-induced IL-23 production is not regulated through the PI3K pathway in human MDMs. (Page 130)

Fig. 3.3.11 IFN- γ /LPS-induced IL-23 production is not regulated through the JAK/STAT pathway in human MDMs. (Page 132)

Fig. 4.1.1 IFN- γ induces IL-27 expression in primary human monocytes isolated by positive selection. (Page 136)

Fig. 4.1.2 IFN- γ stimulation of negatively selected monocytes and CD14-activated monocytes isolated by negative selection triggers IL-27 production. (Page 138)

Fig. 4.1.3 IFN- γ -induced IL-27 production is not regulated by JAK/STAT pathway in human monocytes. (Page 141)

Fig. 4.1.4 IFN- γ -induced IL-27 production is positively regulated through the JNK MAPK pathway in human monocytes. (Page 145)

Fig. 4.1.5 IFN- γ -induced IL-27 production is not regulated through the p38 MAPK pathway in human monocytes. (Page 147)

Fig. 4.1.6 IFN- γ -induced IL-27 expression is not regulated by the ERK MAPK signaling pathway. (Page 149)

Fig. 4.1.7 IFN- γ -induced IL-27 production is positively regulated through the PI3K pathway in human monocytes. (Page 152)

Fig. 4.1.8 LPS-induced IL-27 production is positively regulated through the PI3K pathway in THP-1 cells. (Page 154)

Fig. 4.2.1 LPS and IFN- γ /LPS induce IL-27 expression in the pro-monocytic cell line, THP-1. (Page 159)

Fig. 4.2.2 LPS and IFN- γ /LPS induce IL-27 expression in monocyte-derived macrophages. (Page 161)

Fig. 4.2.3 LPS-induced IL-27 production is positively regulated through the JNK MAPK pathway in THP-1 cells. (Page 164)

Fig. 4.2.4 JNK MAPK siRNA inhibits LPS-induced IL-27 expression in THP-1 cells. (Page 166)

Fig. 4.2.5 LPS-induced IL-27 production is positively regulated through the p38 MAPK pathway in THP-1 cells. (Page 168)

Fig. 4.2.6 p38 MAPK siRNA inhibits LPS-induced IL-27 expression in THP-1 cells. (Page 170)

Fig. 4.2.7 IFN- γ /LPS-induced IL-27 production is positively regulated through the JNK MAPK pathway in human MDMs. (Page 173)

Fig. 4.2.8 IFN- γ /LPS-induced IL-27 production is positively regulated through the p38 MAPK pathway in human MDMs. (Page 175)

Fig. 4.2.9 IFN- γ /LPS-induced IL-27 production is not regulated through the ERK MAPK pathway in human MDMs. (Page 178)

Fig. 4.2.10 LPS-induced IL-27 production is positively regulated through the PI3K pathway in THP-1 cells. (Page 180)

Fig. 4.2.11 PI3K MAPK siRNA inhibits LPS-induced IL-27 expression in THP-1 cells. (Page 182)

Fig. 4.2.12 IFN- γ /LPS-induced IL-27 production is positively regulated through the PI3K pathway in human MDMs. (Page 185)

Fig 4.2.13 IFN- γ /LPS-induced IL-27 production is not regulated through the JAK/STAT pathway in human MDMs. (Page 187)

Fig. 5.1.1 IFN- γ /LPS-induced IL-27 EBI3 subunit expression is positively regulated through the JNK, p38 MAPK and PI3K pathway in human MDMs. (Page 191)

Fig. 5.1.2 Lysosomal degradation is not implicated in IFN- γ /LPS-induced IL-27 EBI3 or IL-27p28 subunit expression in human MDMs. (Page 194)

Fig. 5.1.3 Proteosomal degradation is not implicated in IFN- γ /LPS-induced IL-27 EBI3 or IL-27p28 subunit expression in human MDMs. (Page 196)

Fig. 5.1.4 IFN- γ /LPS and LPS alone treatment increased TTP mRNA expression in human MDMs. (Page 199)

Fig. 5.1.5 IFN- γ /LPS-induced TTP mRNA expression is negatively regulated through the PI3K pathway in human MDMs. (Page 201)

Fig 5.1.6 IFN- γ /LPS and LPS alone treatment increased cell-surface expression of WSX-1 and gp130 human MDMs. (Page 204)

Fig. 5.1.7 IFN- γ /LPS and LPS alone treatment increased cell-surface expression of WSX-1 and gp130 human MDMs. (Page 206)

Figure 5 A model showing the signalling pathways involved in IL-23 induction following IFN- γ stimulation in human monocytic cells. (Page 214)

Figure 6 A model showing the signalling pathways involved in IL-23 induction following LPS stimulation in THP-1 monocytic cells. (Page 219)

Figure 7 A model showing the signalling pathways involved in IL-27 induction following IFN- γ stimulation in human monocytic cells. (Page 225)

Figure 8 A model showing the signalling pathways involved in IL-27 induction following IFN- γ /LPS stimulation in THP-1 monocytic cells and MDMs. (Page 231)

Table 3 Regulation of IL-23 in response to IFN- γ /LPS in myeloid cells. (Page 240)

Table 4 Regulation of IL-27 in response to IFN- γ /LPS in myeloid cells. (Page 242)

Abstract

IL-12, an immunoregulatory cytokine, plays a key role in the development of cell-mediated immune responses. However, very little is known about the regulation and induction of the other members of this family, particularly IL-23 and IL-27. The regulation of these cytokines was studied in the human primary monocytes and monocyte-derived macrophages (MDMs) as they play a key role in innate and adaptive immune responses. THP-1 promonocytic cells were employed as a model system to confirm the results obtained with monocytes and MDMs. Two stimuli IFN- γ and LPS were used as both are strong inducers of IL-12 family cytokines.

My results show that IFN- γ induced the production of IL-12/23p40 and IL-23p19 mRNA as well as IL-12p40 and IL-23 proteins in primary human monocytes isolated by positive selection. IFN- γ -induced IL-23 and IL-12/23p40 expression was positively regulated by the p38 mitogen-activated protein kinases (MAPK), independent of the Janus kinase (Jak)/signal transducers and activators of transcription (STAT) signaling. In contrast, IL-12 and IL-23 were negatively regulated by the Jak/STAT, phosphoinositide-3 kinase (PI3K) and the c-Jun-N-terminal kinase (JNK) MAPKs in IFN- γ -stimulated monocytes.

LPS significantly stimulated IL-23p19 and IL-12/23p40 mRNA expression as well as IL-12/23p40 and IL-23 protein production in THP-1 cells, while IFN- γ stimulation alone did not affect IL-23 mRNA or protein levels. THP-1 cells were pre-treated with ERK, JNK or p38 MAPK inhibitors and then stimulated with LPS. LPS-induced IL-12p40 and IL-23 proteins were positively regulated by the p38 and JNK MAPKs and PI3K, whereas LPS-induced IL-23p19 mRNA expression was negatively regulated by these kinases. These results were confirmed using siRNA in LPS-stimulated THP-1 cells. My results also show

that IFN- γ /LPS-induced IL-23 expression is not regulated through MAPK or PI3K signaling pathways in human MDMs.

My results also show for the first time that IFN- γ alone without any second stimulus induced IL-27p28 gene expression and IL-27 protein production in human monocytic cells. I investigated the signalling pathways governing the regulation of IL-27 protein and its subunit IL-27p28 following stimulation with IFN- γ in primary human monocytic cells. IFN- γ -mediated IL-27 protein, but not IL-27p28 gene expression was positively regulated by JNK MAPK and PI3K, independent of JAK/STAT signaling in primary human monocytes.

I also investigated the signalling pathways governing the regulation of IL-27 and its α subunit, IL-27p28 following stimulation with IFN- γ alone or IFN- γ -primed LPS-stimulated macrophages (IFN- γ /LPS) and THP-1 cells. A differential regulation of IL-27p28 and IL-27 in response to stimulation by either IFN- γ or IFN- γ /LPS was observed. IFN- γ - and IFN- γ /LPS induced IL-27 expression was positively regulated by the JNK, p38 MAPK and PI3K, independent of Jak/STAT signaling in human MDMs and THP-1 cells. Taken together, my results show that IL-23 induction is differentially regulated by different pathways in response to different stimuli, whereas IL-27 expression is regulated by JNK, p38 MAPK and PI3K regardless in the stimulus in human myeloid cells. These results may provide additional strategies aimed at targeting disease, autoimmune disorders and cancer.

Chapter 1 Introduction

Cytokines are cell-signaling protein molecules that act as immunoregulators, immunomodulators and inter-cellular communicators (1). Cytokines are usually synthesized in the cytoplasm, translocated across the endoplasmic reticulum (ER) through the Golgi apparatus to the plasma membrane directly or through secretory granules (2). There is also a non-canonical cytokine secretion pathway, independent of the ER-Golgi complex, where proteins are released from the cytosol via microvesicles (3). Cytokines can also be packaged in the Golgi body for storage in secretory vesicles to be secreted during receptor-mediated activation (2).

IL-12, an immunoregulatory cytokine, plays a crucial role in cell-mediated immune responses (4). Two heterodimeric cytokines, IL-23 and IL-27 have been recently described (Figure 1). These two cytokines are structurally related to IL-12 and exhibit biological functions similar to IL-12 (5-7). Similarly to IL-12, they are produced by monocytes/macrophages and dendritic cells (DCs) (5, 6, 8). Monocytes/macrophages and DCs are professional antigen presenting cells (APC) and important sources of T-helper cell 1 (Th1) cytokines.

IL-12 production has been shown to be regulated via LPS-induced c-Jun N-terminal kinase (JNK) mitogen-activated protein kinase (MAPK)-dependent AP-1 and $\text{NF-}\kappa\text{B}$ activation (9, 10). While the signalling pathways responsible for IL-12 expression in murine and human DCs have been examined (4, 11-14), the mechanisms responsible for IL-23 and IL-27 expression in monocytes/macrophages remain unknown. Some reports investigated their mRNA level (15-18), however, little is known about the regulation of IL-23 and IL-27 protein production.

Figure 1 The IL-12 cytokine family and its receptors. IL-12 is a heterodimer cytokine composed of a light chain (IL-12p35) and a heavy chain (IL-12p40). Its receptor comprises IL-12 β 1 and IL-12 β 2, which share homology with gp130. IL-12p40 can dimerise with the light chain IL-23p19 in order to form IL-23. The IL-23 receptor is formed by the association of IL-12 β 1 with IL-23R. IL-27 is composed of the light chain IL-27p28 and a heavy chain, EBI3. IL-27 binds to its receptor comprised of gp130 and WSX-1 (19).

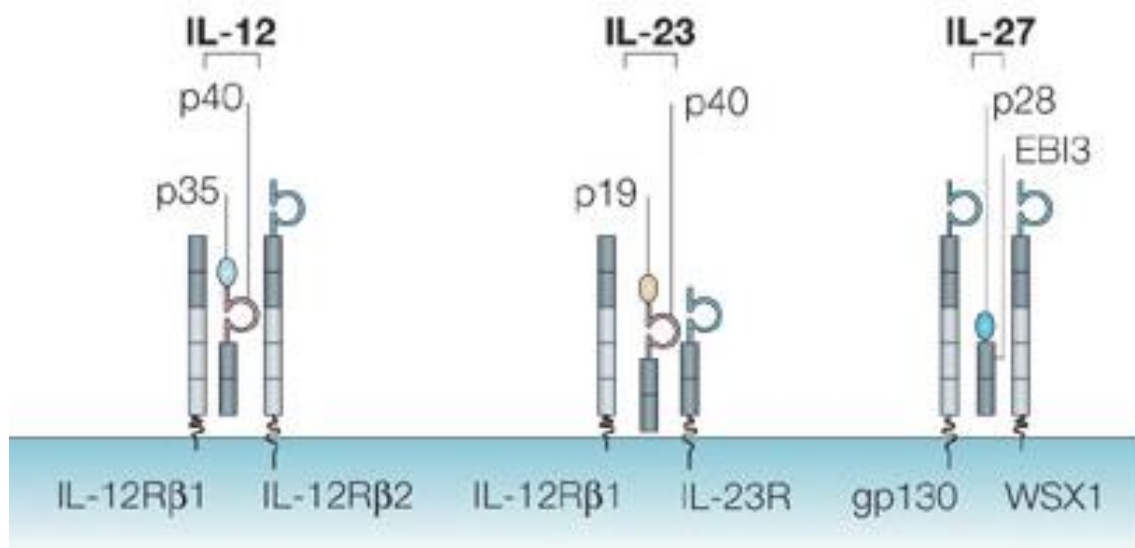

Figure 1

In light of these issues, my thesis will ask the following questions: a) what governs the regulation of IL-23 and IL-27 in human monocytic cells and macrophages; b) what are the possible signalling pathways involved in this regulation.

Monocytes and Macrophages

Monocytes are leukocytes produced by the bone marrow from hematopoietic stem cell precursors. They circulate in the bloodstream for about one to three days and then typically move into tissues throughout the body, in response to inflammatory signals. Once they migrate into tissues, monocytes mature into macrophages or dendritic cells, according to the stimuli they receive in the microenvironment. Microbial products can directly activate monocytes and this leads to production of pro-inflammatory and with some delay of anti-inflammatory cytokines. Typical cytokines produced by monocytes are TNF, IL-1, and IL-12.

Macrophages are tissue-resident cells, derived from the maturation of extravasated peripheral blood monocytes. They are part of the innate immune system and play the key role of professional antigen-presenting cells that offer surveillance of tissues and phagocytose and digest invading pathogens and apoptotic cells (20). They display antigen peptides along with major histocompatibility complex (MHC) on their cell surfaces. Upon ingestion of pathogens, macrophages are carried via the lymphatic system to draining lymph nodes, where they present the digested pathogen into smaller pieces containing epitopes, which are then presented to T cells using MHC. Upon activation, macrophages produce a variety of proinflammatory cytokines, followed in a temporal sequence by secretion of anti-inflammatory mediators in order to limit exposure of surrounding tissues to inflammation (21). Macrophages contribute to innate and adaptive immune responses against viruses by

secreting interferon (IFN)- α , - β , IL-12 and IL-18 and inducing IFN- γ production in natural killer (NK) cells and cytotoxic T cells (22).

IL-12 cytokine

The main producers of IL-12 are phagocytes (monocytes and macrophages), neutrophils and dendritic cells (DC) in response to various pathogens, such as bacteria, fungi and viruses (3, 23). IL-12, a heterodimeric cytokine, is made up of a 35-kDa light chain, p35, and a 40-kDa heavy chain, known as p40 and their dimerization occurs in the endoplasmic reticulum (ER) (24). This ER interaction pathway may also be used by the other heterodimeric cytokine members of the IL-12 family, namely IL-23, IL-27 and IL-35 (3, 25, 26). Both of these genes are expressed in order to produce biologically active IL-12, although it has been suggested that the expression of p35 may be the rate limiting for the secretion of IL-12 heterodimer (24). IL-12 is critical for differentiation and proliferation of naïve CD4⁺ T cells into Th1 cells, being a potent inducer of IFN- γ production by CD8⁺ T cells, natural killer cells and natural killer T cells. Therefore, APCs act as a bridge between the innate and adaptive immune responses through IL-12 production (27).

IL-12 family of cytokines

IL-12 cytokine was first reported in 1989 and its role in promoting differentiation of naïve CD4⁺ T cells into mature Th1 effector cells was rapidly established. Furthermore, IL-12 plays a dominant role in driving naïve T cells to generate into Th1 cells leading to secretion of IFN- γ , thereby stimulating immune responses in order to eradicate intracellular and extracellular pathogens (28). Generally, natural killer (NK) and T cells are the cellular targets of all IL-12 cytokine family. Overexpression of IL-12 causes pro-inflammatory

responses, leading to auto-immune pathogenesis. The IL-10 cytokine is a potent inhibitor of IL-12 production (14, 29), exerting its inhibitory effects by downregulating the activation of the transcription factors NF- κ B and AP-1 (30, 31).

Several subunits of the IL-12 family, namely IL-12p35, IL-23p19, IL-27p28 and EBI3 are expressed in a variety of cells types. However, IL-12p40 transcription appears to be restricted to APCs (32). IL-12p35 requires IL-12p40 for secretion, and secretion of IL-23p19 and IL-28p28 also depends on their ability to partner with the small family of secreted type I cytokine receptors, such as IL-12p40 and IL-27 EBI3, respectively (28, 33). Expression of IL-12 family is induced by pathogen-associated molecular patterns (PAMPs), which are ligands for toll-like receptors (TLRs) on APCs. IL-12 expression is generated by TLRs that were engaged by the PAMPs present on bacterial, fungal or viral microorganisms (23). When APCs interact with microbial products, they communicate with T cells by producing a variety of soluble factors and peptide-MHC/TCR cell to cell interaction. Thusly, they will produce a variety of soluble factors responsible for expanding and differentiating naïve T cells in order to generate mature T cell phenotypes, such as Th1 and Th2 helper cells (28). It has been shown that IL-4, IFN- γ and IL-13 are necessary for optimal IL-12 production (23, 32). However, the precise role of IFN- γ -induced IL-23 and IL-27 expression in monocytes/macrophages is not known.

Even though APCs express functional receptors for all members of the IL-12 cytokine family, (34-36), it is believed that IL-12, IL-23 and IL-27 may have overlapping, but also distinct roles in regulating immune responses, eliminating redundancy in their effects on the intracellular milieu (8, 23, 32). It has been shown that different components of the receptors for these cytokines are expressed on different target cells. Also, IL-12, IL-23 and IL-27 act at different developmental stages of the target cells, such as naïve versus

memory T helper cells (32). Naïve Th cells express receptors for IL-27 and IL-12, but not for IL-23 (37), while memory Th cells express receptors for IL-23, having low cell-surface expression of receptors for the IL-27 or IL-12 cytokines (32, 33).

IL-23 and its biological properties

In 2000, Oppmann et al. demonstrated that the IL-23p19 subunit, a four- α helix cytokine sharing sequence identity of approximately 40% with IL-12p35, has no biological activity by itself, but binds to IL-12p40 to form a new cytokine, IL-23, with similar as well as distinct biological roles as IL-12 (33). IL-23 is produced primarily by monocytic and dendritic cells (DCs) (19, 33). It is a heterodimeric cytokine composed of the p40 subunit, which is shared with IL-12, and a p19 subunit unique to IL-23. Expression of the two subunits is tightly regulated and IL-23p19 is poorly secreted in the absence of IL-12/23p40 (33). Similar to IL-12, IL-23 induces differentiation and proliferation of Th1 cells and the development of cell-mediated immunity (19, 38). Specifically, IL-23 induces proliferation and IFN- γ production of CD4⁺ memory T cells whereas naïve T cells do not respond to this cytokine (19).

IL-23 plays a crucial role in host defences against invading pathogens by coordinating the innate and adaptive immune responses (19, 33). Initially, IL-12-dependent Th1 cells were thought to be the cause for the induction of autoimmunity in several diseases, based on the effects observed by neutralizing IL-12p40 antibodies. Nevertheless, IL-23 has been demonstrated to be the key player in the development of several autoimmune disease such as multiple sclerosis (MS) and experimental autoimmune encephalitis (EAE). Recently it has been discovered that IL-23 plays an essential role in the maintenance of IL-17-producing Th17 cells. The main distinguishing feature of IL-23 is its ability to induce

generation of Th17 cells and IL-17 production (39, 40). The IL-23-Th17 pathway plays a key role in the induction of inflammatory cytokines and pathogenesis of autoimmune disorders such as experimental autoimmune encephalomyelitis, multiple sclerosis, psoriasis, colitis, Crohn's disease, rheumatoid arthritis (40-47) and resistance to various pathogens such as *Cryptococcus neoformans*, and *Klebsiella pneumonia* (48, 49). Moreover, anti-IL-23 antibodies have been used effectively in animal models of inflammatory and autoimmune diseases (42, 43). Daily injections with IL-23 in wild-type mice led to a psoriasis-like phenotype with visually apparent erythema and induration. This was correlated with prominent dermal papillary blood vessel formation and possibly vasodilation as soon as 2 days after starting treatment (50). Histological examination of the skin, displayed epidermal hyperplasia and a mixed dermal infiltrate consisting of neutrophils, macrophages, CD11c⁺ DCs and CD4⁺ T cells as early as 1 day after IL-23 treatment. Importantly, these activities were unique to IL-23, as IL-12 does not induce changes in epidermal thickness when injected into skin. Recently, the impact of IL-23 on autoimmunity and chronic inflammation became well established. High levels of IL-23p19 expression have been observed in microglial cells from multiple sclerosis lesions (51). However, the role of IL-23 in protecting against infectious disease is still poorly understood.

The IL-23 receptor is made up of two subunits, the IL-12R β 1 chain shared by IL-12 and an IL-23-specific chain IL-23R (23, 50, 52). Therefore, any similarity in biological functions shared by IL-12 and IL-23 may be explained by the sharing of IL-12 and IL-23 receptor subunits. IL-23R has been found to be expressed on a variety of cell types, including T cells, NK cells, monocytes, DCs in humans and macrophages in mice (53). The IL-23R subunit of the IL-23 receptor is not expressed on naïve CD4 T cells (53). Various cytokines, such as TGF β , IL-6 and IL-21 have been shown to induce IL-23R expression (54, 55).

The critical role that IL-23 plays in the development of the Th17 cell phenotype has been shown in IL-23p19-deficient mice that cannot produce Th17 cells *in vivo* (41). The IL-23/17 axis is now established as an important mediator of inflammation, playing an important role in autoimmune disease pathogenesis. Over-expression of IL-23 leads to a systemic inflammatory response in transgenic mouse models (56). IL-23 has been shown *in vitro* to induce IFN- γ production by DCs (7, 34) and long-lasting CD4⁺ and CD8⁺ T cell immunity (6, 23). Studies have also shown that DCs and macrophages produce IL-23 rapidly after exposure to LPS and other pathogens (40). This interaction will activate IL-17 responses from tissue-resident T cells including $\alpha\beta$, $\gamma\delta$ and NK T cells. The same study showed that IL-17 can promote IL-1, IL-6, IL-8 and TNF- α expression in stromal, epithelial, endothelial cells and monocytes (40).

IL-27 and its biological properties

IL-27 was discovered in 2002 as yet another heterodimeric cytokine, sharing subunit homology with IL-12. IL-27 is made up of the Epstein-Barr virus-induced gene 3 (EBI3) and p28 (26). IL-27p28, the α subunit, is related to the IL-12p35 polypeptide, while IL-27 EBI3 (β subunit) is related to the IL-12p40 subunit of IL-12 (57). While IL-12 and IL-23 cognate subunits are linked together by disulphide bonds, the IL-27 subunits are linked only by covalent bonds. Absence of disulphide bonds may allow for production of the two subunits by different cell type, followed by extracellular association (58).

IL-27 signals through the IL-27 receptor complex, which is expressed widely within the immune system. Its action is mediated through IL-27 receptor consisting of the orphan cytokines receptor WSX-1/TCCR and gp130. Gp130 is also shared with the IL-6 receptor family and is being part of other cytokine receptors, such as IL-6R and IL-11R (59). WSX-1

was first identified through a homology search of human gp130 cDNA sequence query. Full cDNA sequence analysis for murine and human WSX-1 were isolated and characterized. It was also discovered that WSX-1 shares homology and is structurally similar to gp130 (60). Furthermore, studies have shown that the IL-27 receptor is expressed on a variety of cell types, such as monocytes/macrophages, Langerhans' cells, activated DCs and endothelial cells (32, 61, 62). The IL-27/WSX-1 signaling complex activates STAT-1, which in turn on the Th1 transcription factor T-bet expression in order to initiate Th1 differentiation of naïve CD4⁺ T cells (26, 63).

As previously mentioned, one of the crucial roles that IL-27 plays it to activated the Th1 master transcriptional regulator, T-bet, in order to differentiate naïve T cells into Th1 phenotype and regulation of immunoglobulin class switching in B cells. Recent studies have shown that IL-27 enhances cytotoxic T cells (CTL) activity, making IL-27 the focus of potential antitumor therapies. IL-27 over expression showed to have potent antiangiogenic properties in murine colon carcinoma C26 cells, TBJ neoblastoma cells, or B16F10 melanoma cells (64-68). The anti-tumor and anti-metastatic properties of IL-27 were further confirmed when it was shown that IL-27 can suppress neovascularization of tumours in chick embryonic tumours (69). On the other hand, IL-27EBI3 has been demonstrated in EBV-transformed B cell lines and human T-cell leukemia virus type 1 (HTLV-1)-infected cell lines. However, IL-27p28 or IL-27 expression levels were not detected in these cells. This puzzling activity of EBI3 may suggest that it can act independently from its association with IL-27p28, in regulating anti-viral or anti-tumoral immune responses (70). This can further be explained by the fact that EBI3 associates with the IL-12p35 subunit, forming the recently described heterodimeric cytokine, IL-35.

There is some debate on whether IL-27 can be considered a proinflammatory or anti-inflammatory cytokine. IL-27 can synergize with IL-12 to enhance Th1 polarization, and IFN- γ production (26). Furthermore, IL-27 also synergizes with IL-2 or IL-12 to enhance IFN- γ secretion from NK cells (26). IL-27 has been described as an anti-inflammatory cytokine since it can suppress the secretion of proinflammatory cytokines, such as IL-23-induced IL-17 from activated T cells (71). Furthermore, IL-27 is a potent suppressor of autoimmune activity in disease models that are primarily driven by IL-17-producing Th17 cells (72)(73). Inflammatory tissue damage in IL-27^{-/-} mice infected with *T. gondii* was associated with increased expression of IL-2 (74), while neutralization of IL-2 in the same mice extended their survival (75). Another cytokine antagonized by IL-27 production is IL-6, a potent pro-inflammatory cytokine with roles in a variety of inflammatory diseases. Addition of IL-27 to a T cell proliferation assay completely ablated the proliferation-inducing effect of IL-6, suggesting that IL-27 neutralizes the effects of IL-6 through direct effects on effector T cells (Batten M, Li J, Yi S et al, 2006). IL-27 expression was also found to have pro-inflammatory effects. IL-27p28 and IL-27EBI3 mRNA were found to be up-regulated in Crohn's disease. The stimulatory effects of IL-27 on naïve T cells synergized IL-12 in order to trigger IFN- α production, contributing to a feedback loop in the perpetuation of inflammatory processes in Crohn's disease (76).

As previously mentioned, heterodimeric complexes can form additional members in the IL-12 family cytokine. IL-27EBI3 and IL-12p35 can complex in order to form IL-35 (28, 77). Studies have shown that regulatory T cells, defined by a CD4⁺ CD25⁺ FoxP3⁺ phenotype, can produce both IL-27EBI3 and IL-12p35. This newly discovered cytokine is biologically active and can inhibit T regulatory cell function (25, 78).

IL-27 can induce up to 28 IFN-inducible genes (IFIG) in human MDMs and 5 IFIG in CD4 T cells (79). Therefore, IL-27 may be studied as an anti-HIV cytokine, similar to IFN- α . Studies have shown IL-27 to inhibit HIV (80) and HBV (81) replication. Furthermore, Guzzo et al. observed a trend for decreased IL-27 production in the serum of HIV-infected individuals (82).

Inducers of IL-12 family

IL-12 family cytokine expression are produced by activated monocytes/macrophages and DCs. A wide variety of pathogens have been described as to induce production of IL-12, IL-23 and IL-27 in a variety of myeloid cells. These pathogens are *Francisella tularensis* (83), *Salmonella enteritidis* (84), *Bordetella pertussis* (85), *Mycobacterium tuberculosis* (86), Theiler's murine encephalomyelitis virus (TMEV) (87), Sendai virus (88) and Hepatitis B (89). Furthermore, a variety of PAMPs acting as TLR agonists can increase production of IL-12, -23, -27 cytokines in monocyte/macrophages and DCs (23, 28, 90). IL-23p19 mRNA expression was induced in murine bone marrow-derived myeloid DCs and plasmacytoid DCs upon stimulation with TLR 3, 4, 7 and 9 ligands. However, in the case of plasmacytoid DCs, IL-23p19 mRNA was not translated into protein (91), underlining a differential regulation of each IL-12 family subunit.

IFN- γ and the JAK/STAT signaling pathway

IFN- γ , a dimerized cytokine and the sole member of the type II interferon group was discovered in 1970 (92). It is primarily produced by T and NK cells, but also B cells, NKT cells and professional APCs in response to viral and intracellular bacterial infections (93). Furthermore, it plays a critical role in mounting effective immune responses against tumours.

Conventionally, the biological effects of IFN- γ are elicited through activation of the Janus kinases (JAK)/STAT pathway, starting with the binding of IFN- γ to its cell surface receptors, IFN- γ R1 and IFN- γ R2 (Figure 2). This results in the oligomerization of the receptor subunits. JAK1 and JAK2 are members of the JAK family of kinases and are associated with IFN- γ R1 and IFN- γ R2, respectively, prior to activation. The oligomerization of the IFN- γ receptor subunits brings these kinases into close proximity, allowing them to transphosphorylate each other. The phosphorylation of IFN- γ R1 will not provide a docking site for the SH2 domain of the transcription factor STAT1 (94). Phosphorylated STAT1 will form a homodimer that is translocated into the nucleus and initiates a variety of transcription of genes (95). Recently, it has been shown that some biological effects of IFN- γ can occur in the absence of JAK/STAT signaling. It has been proposed that in the absence of STAT1, IFN- γ signaling can be maintained through compensation of other STAT members (96). The IFN receptors have been shown to interact directly with the p85 subunit of PI3K, independently of JAK-mediated phosphorylation of the receptor (97, 98). IFNGR1 has also been shown to interact directly with MyD88 (99), which may trigger activation of the MKK6/p38 MAPK pathway (99), possibly through Pyk-2 activation (100). Furthermore, IFN- γ has also been shown to activate JNK MAPK in macrophages (101), although the precise sequence of events leading to JNK MAPK activation is not known. Interestingly, IFN- γ has also been shown to negatively regulate LPS-induced IL-23 production in murine macrophages (102). Whether IFN- γ alone can induce the production of IL-23, IL-12p40 or IL-23p19, in human monocytes remains unknown. The complete elucidation of STAT-1-independent IFN- γ signaling is crucial to understand multiple immune responses.

Figure 2 The signaling pathway of Interferon-(IFN-) γ and its receptor. The IFN- γ receptor has two subunits: IFN- γ R1, the ligand-binding (α) chain, and IFN- γ 2, the signal-transducing (β) chain. Upon IFNGR1 interaction with IFN- γ , the α chains dimerise and associate with two β chains. This receptor assembly activates Janus kinases JAK1 and JAK2, recruiting signal transducer and activator of transcription-1 (STAT-1). STAT-1 will form homodimers and translocates to the nucleus to activate a wide range of IFN- γ -responsive genes (Cambridge University Press).

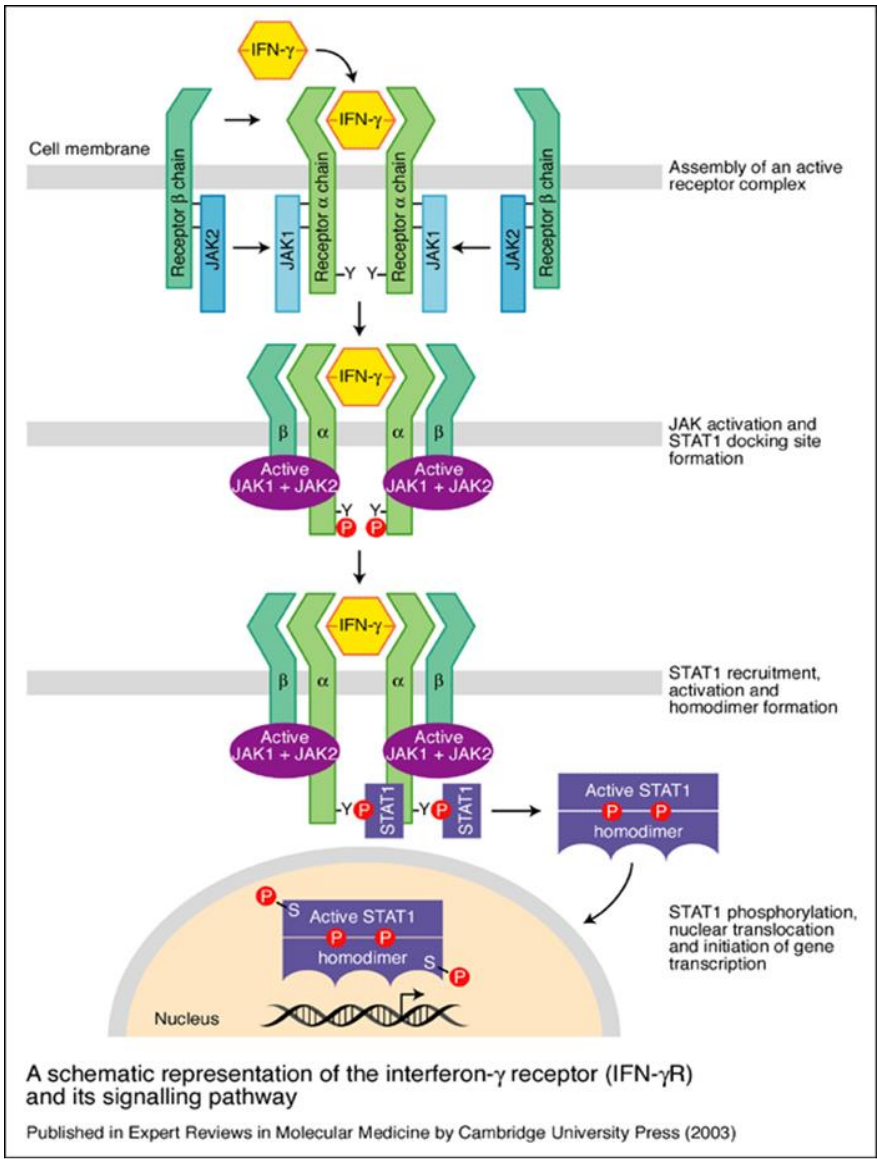

Figure 2

IFN- γ -mediated expression of the IL-12 cytokine family

IFN- γ mediates its biological effects primarily via the activation of Janus kinase (Jak)/signal transducers and activators of transcription (STAT) pathway (103) as seen in Figure 4. IFN- γ has also been shown to activate MAPKs (104), PI3K (105) and Src kinases (106) in a STAT-1-independent manner (103). The signalling pathways regulating IL-12p40 expression in LPS-stimulated monocytic cells have been identified (11, 12, 46, 107, 108). However, very little is known about the regulation of IL-23 (109-112). LPS-induced IL-23p19 was negatively regulated by Rac1 through the NF- κ Bp65 transactivation-dependent and I κ B independent pathway in PMA-treated THP-1 macrophages and human DCs without affecting IL-12/23p40 induction (112). IL-23p19 expression was also regulated by c-rel in murine DCs stimulated with TLR-2, -3, -4, -6 and -9 agonists (109). IFN- γ primes the IL-12p40 promoter so that transcription can occur in the presence of a second stimulus, such as LPS (113-115). IFN- γ can promote IL-12p40 transcription via induction of interferon regulatory factors (IRFs). Studies have shown that a number of IRFs, in particular IRF-1, 2, 5, 7 and 8 are involved in the regulation of IL-12p35 and IL-12p40 transcription (116). In IRF 1 and 2 knock-out murine models, it was shown that IL-12p35 and IL-12p40 expression is defective, while in the IRF8 knock-out model IL-12p40 was not expressed (108, 117, 118). IFN- γ can also enhance IL-23 production during *Francisella tularensis* infection in human monocytes (83).

IFN- γ primes cells for heightened responses to LPS

It has been previously described that IFN- γ increases sensitivity and cytokine production in cells in response to endotoxins (160), in particular it primes macrophages for a more rapid and heightened response to LPS (161)(162). Priming with IFN- γ induces a

variety of genes in response to LPS stimulation, such as iNOS (163), although IFN- γ does not prime all of LPS-induced genes (164). Murine models with IFN- γ receptor knock-out were highly resistant to LPS-induced toxicity (165). Therefore, IFN- γ can be produced during endotoxins responses and serves to amplify cellular responses to the various invading pathogens.

Studies in murine bone marrow macrophages show that optimal IFN- γ priming for TLR agonists responses was at 16 hours (166). IFN- γ was shown to upregulate transcription of TLR4 and LPS-binding abilities in macrophages (167-169) and expression of the MD-2 accessory molecule, the MyD88 adaptor and IRAK, all crucial molecules in the LPS signaling pathway (167, 170). Furthermore, in human monocytes, priming with IFN- γ induces activation of NF- κ B upon stimulation with LPS (171). Interestingly, IFN- γ priming can also enhance TNF- α responses, a macrophage-derived cytokine secreted in response to LPS in myeloid cells (172, 173).

Specific interactions between the pathways activated upon IFN- γ and LPS exposure must occur before transcriptional activation may occur (93). For example, LPS stimulation, following IFN- γ treatment can increase STAT-1 phosphorylation, augmenting IFN- γ -dependent STAT-1-mediated gene expression (174, 175). However, IFN- γ and LPS may employ different signaling pathways for STAT-1 activation, since LPS-induced STAT-1 phosphorylation was ablated by p38 MAPK inhibition, while IFN- γ -induced phosphorylation was not (176). This synergy between LPS and IFN- γ -induces transcription of genes, such as IRF-1, IP-10, ICAM-1 (177, 178) may be explained by a need to tightly coordinate the activation of immune responses after encountering various pathogens.

Toll-like receptor (TLR) signaling

The Toll-like receptor (TLR) family is a group of receptors present on a variety of cell types that mediate innate and adaptive immune responses. In humans, the TLR family comprises 10 TLRs (TLR1 to TLR10) subtypes and the IL-1 receptor (IL-1R) (119). TLRs are transmembrane glycoproteins (119), sharing homology in their cytoplasmic tails. However, they have distinct extracellular or endosomal domains recognizing specific, conserved, microbial ligands (120). TLR-induced signal transduction has been linked to either myeloid differentiation primary response protein 88 (MyD88) and/or TIR-domain-containing adapter-inducing interferon- β (TRIF)-dependent signaling pathways. The activation of either MyD88 or TRIF pathways leads to the activation of adaptor proteins including IL-1R associated kinase (IRAK) and TNF-associated (TRAF) signaling molecules which leads to the activation of TGF- β activated kinase 1 (TAK-1) (121-124).

LPS signaling pathways

Lipopolysaccharide (LPS) is found in the outer membrane of Gram negative bacteria, contributing to its structural integrity. It is a large molecule consisting of a lipid and a polysaccharide, joined together by a covalent bond (Figure 3). LPS binds to LPS-binding protein (LBP) in plasma and is delivered to the cell surface receptor CD14, present on myeloid cells (121) (Figure 4). CD14 is a glycoprotein that has been detected in its soluble form in plasma and breast milk (sCD14). CD14 is anchored in the cell membrane without a transmembrane segment that allows for signal transduction (122, 123). Previously, it has been shown that soluble CD14 is able to activate monocytic cells in the absence of bacterial components or serum (124). TLR4 display a leucine-rich motif to the extracellular domain for interaction with LPS, mediating its signaling. Furthermore, MD2 associates with LPS

signalling in monocytes. Through the activation of the CD14-TLR4-MD2 complex, which in turn activates the PI3K pathway (121), permitting docking of PI3K to the plasma membrane. Upon TLR4 activation, MyD88 is recruited to the TLR4 receptor and interacts with IL-1R-associated kinase (IRAK)-4 (125). IRAK4 will in turn activate other members of the IRAK family, resulting in the recruitment of TRAF6. This will activate a complex containing TGF- β -activated kinase (TAK1) and TAK1-binding proteins (TAB) (126). The TAK1/TAB complex triggers the MAPK and NF- κ B signaling pathways, including JNK and p38 MAPK (126). Studies have shown that LPS-TLR4 signaling in human monocytes also activates Akt. Akt may directly or indirectly activate MAPKs (121).

Mitogen-Activated Protein Kinase (MAPK) cascade

The responses of the immune system are regulated through an extensive array of interconnected and tightly controlled intracellular signaling pathways (127). Diverse extracellular stimuli such as growth factors, cytokines, stress and osmotic shock may activate a signal transduction pathway from the cell surface to the nucleus. The mitogen-activated protein kinase (MAPKs) family of serine/threonine protein kinases is highly conserved across eukaryotic species. These cytoplasmic protein kinases play a key role in many cellular processes such as apoptosis, proliferation and immune defence (128). In mammalian cells the MAPK pathways are: the N-terminal c-jun kinases (JNK), p38 and the extracellular signal-regulated kinases (ERK1 and ERK2) (129). These pathways are activated upon the engagement of particular stimuli to their respective cell-surface membrane-bound receptors. MAPKs are activated through a cascade of sequential phosphorylation events, starting with the phosphorylation of MAPK kinases at two serine residues by MAPK kinase kinases (128).

Figure 3 Structure of LPS. Lipopolysaccharide is a component of the outer membrane of Gram-negative bacteria cell wall. LPS is comprised of three parts: O-antigen (the outermost domain of the LPS molecule), Core and Lipid A. The hydrophobic fatty acids of Lipid A anchor the LPS molecule into the bacterial membrane, while the rest of LPS projects outward (121).

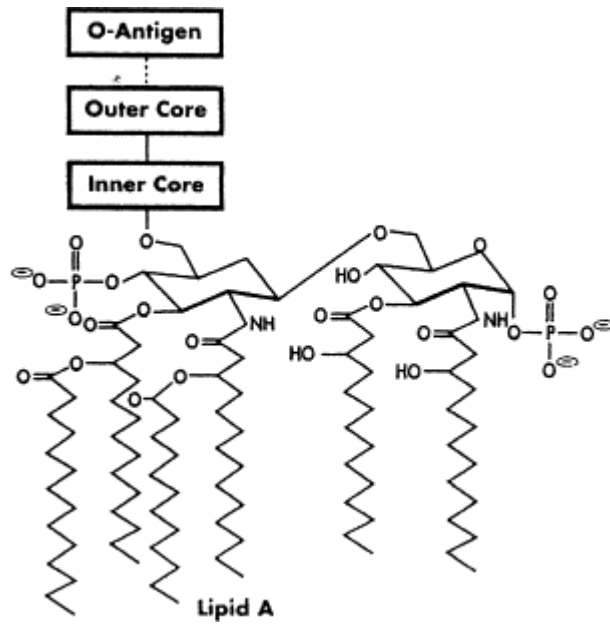

Figure 3

Figure 4 LPS stimulation activates a variety of signaling pathways and transcription factors. LPS forms complexes with a plasma protein called LPS-binding protein (LBP) and it is transferred to the CD14 at the cell surface. LPS then interacts with Toll-like receptor 4 (TLR4) and the accessory protein MD-2. This interaction activates the JNK, p38 and ERK MAPK pathways, which will directly or indirectly phosphorylate various transcription factors. LPS may also activate the IKK pathways via MyD88, which will permit the nuclear translocation of NF- κ B. The PI3K/Akt pathway is also activated by LPS stimulation via kinases (121).

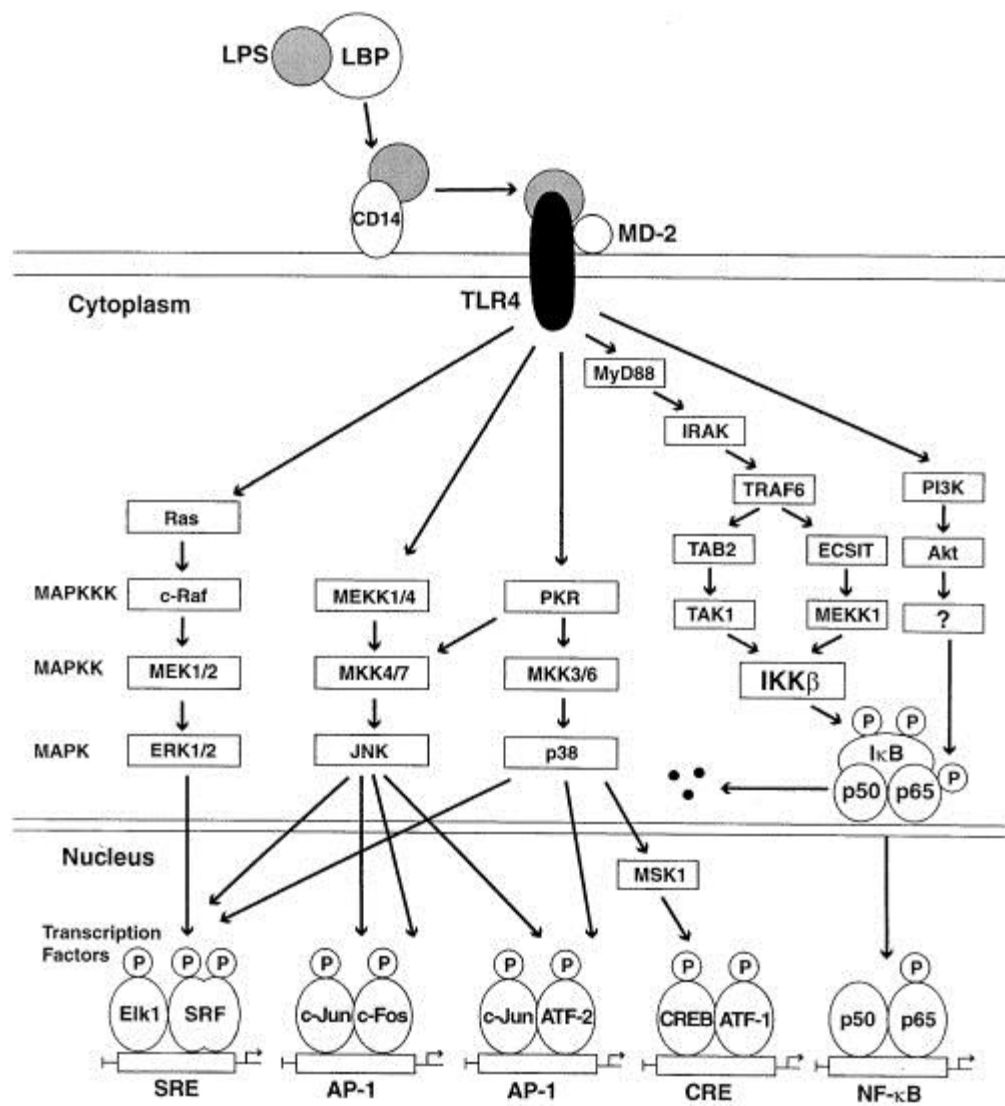

Figure 4

Afterwards, phosphorylated MAPKKs proceed to activate MAPKs at adjacent threonine and tyrosine residues at the conserved Thr-X-Tyr motif, where the X amino acid corresponds to glutamic acid in ERK, proline in JNK and glycine in p38, causing a conformational change. These activated MAPKs can further phosphorylate transcription factors that govern the expression of MAPK-regulated genes (130). It has been demonstrated that MAPK signals can converge and cooperate with other ligand-induced signaling pathways, leading to complex cross-talking mechanisms (131). These integrated signals can modulate the MAPK pathways, offering great diversity in determining cellular responses to environmental stimuli.

JNKs are usually characterized as stress-activated protein kinases that can phosphorylate the DNA-binding protein c-Jun and increase its transcriptional activity. JNK was initially described as a 54 kDa stress-activated protein kinase (SAPK), responding to stimuli that also activate p38, such as LPS, UV radiation and stress. JNK protein kinases are encoded by three genes: JNK1, JNK2 and JNK3, however only JNK1/2 are ubiquitously expressed, while JNK3 is expressed only in the brain, heart and testis (127). SP600125 is an anthrapyrazole identified during a high-throughput biochemical screen. It is a reversible ATP-competitive inhibitor that dose dependently inhibits the phosphorylation of c-Jun, the expression of inflammatory genes and activation of human CD4⁺ cell cultures. SP600125 may also partially inhibit p38 MAPK (132).

There are four p38 kinase isoforms: α (SAPK2), β , β_2 , γ (SAPK3) and δ , with expression of these isoforms varying among tissues. p38 α being the best characterized one and expressed in most cell types, including leukocytes and bone marrow (127). p38 MAPK is involved in regulating the expression of many cytokines, having a crucial role in the activation of the immune system. Also, p38 MAPK activation is essential for expression of

inflammatory cytokines such as IL-6, TNF and IL-1 (127). SB203580, 4-(4-fluorophenyl)-2-(4-methylsulfinylphenyl)-5-(4-pyridyl)1 H-imidazole) is a specific inhibitor of p38 α and p38 β , but not other p38 MAPKs (133). It suppresses the activation of MAP kinase-activated protein kinase 2.

ERK was the first identified member of the MAPK signaling family. It has two widely expressed isoforms, ERK1 and ERK2, and it primarily involved in proliferation and differentiation of cells. Ligands for heterotrimeric guanine nucleotide-binding protein (G protein)-coupled receptors activate the ERK1 and ERK2 pathways (134). PD098059, 2-(2'-amino-3'-methoxyphenyl)-oxanaphthalen-4-one, selectively inhibits the MAPK-activating enzyme MAPK/ERK kinase, MEK. It was identified by screening a compound library against a cascade assay measuring the phosphorylation of myelin basic protein, a protein dependent on MEK activation (135). Therefore, it blocks ERK activation by preventing the phosphorylation of its immediate activator, MEK.

One of the most widely used strategies to analyze the function of cell-signaling molecules is the use of specific inhibitors. These chemical inhibitors are extremely useful for identifying the physiological roles of the cell signalling pathways that they inhibit. Ideally, a signaling inhibitor has a high degree of specificity and fails to affect the activity of a number of other protein kinases, such as closely related MAPK family members.

Phosphatidylinositol-3-kinase (PI3K) signaling pathway

The PI3K signaling pathway plays a crucial role in cell growth and survival, being activated by many growth factors and cytokines. It is made up of a large family of lipid and serine/threonine kinases, including a number of phosphatidylinositol kinases (136). PI3-

kinase is implicated in signal transduction by associating with receptor and non-receptor tyrosine kinases. Class IA PI3K are composed of heterodimers subunits p85 and p100 that play an inhibitory adaptor/regulatory and a catalytic role, respectively. The p85 subunit integrates signals from various tyrosine kinase-linked receptors and intracellular proteins, while binding p110 and activating it. There are three isoforms of PI3K Class IA p110 (α , β and δ) that contain amino-terminal p85-p55 interacting region. P85 and p55 have 7 isoforms that are generated through alternate splicing of three genes, all capable of binding p110 (136). The activation of the PI3K pathway, results in the sequential stimulation of AKT. AKT, also known as Protein Kinase B (PKB), is a serine/threonine-specific protein kinase that plays a key role in multiple cellular processes such as glucose metabolism, apoptosis, cell proliferation, transcription and cell migration. It is involved in the PI3K/AKT/mTOR pathway and other signaling pathways.

LY294002, 2-(4-morpholinyl)-8-phenylchromone, is a morpholine derivative of quercetin and a potent reversible inhibitor of PI3Ks. It has no inhibitory effects against several ATP-requiring enzymes, including MAP kinase, PtdIns 4-kinase, protein kinase A and protein kinase C (137). Studies have shown that PI3K 110β positively regulates IL-12 synthesis induced by LPS in human monocyte-derived macrophages and dendritic cells (27). Furthermore, in the same study it was found that the same PI3K subunit, when activated by LPS, it also positively controls JNK1 activity.

Signaling pathways involved in IL-23 regulation

In response to bacterial and viral infection, myeloid cells are able to initiate a wide variety of innate immune responses, such as production of cytokines and nitrogen oxide

(138). Pathogens are able to induce all of the IL-12 family subunits IL-12p35, IL-12p40, IL-23p19, IL-27p28 and IL-27EBI3 expression at the mRNA and protein level (28, 85-90, 139, 140). However, the mechanisms responsible for LPS and IFN- γ -induced IL-23 and IL-27 expression in human myeloid cells and macrophages are still unknown.

IL-23 subunit expression is controlled by the transcription factors NF- κ B and c-Rel. They bind to the promoter site of IL-23p19 and induce its expression in murine models (109, 141). Furthermore, when c-Rel was deleted, IL-23p19 was not expressed in both DCs and macrophages. MAPK signalling pathways, JNK, p38 and ERK were shown to be involved in LPS-induced IL-23p19 gene expression in murine DCs and macrophages (142). TLR2, TLR4 and TLR7/8 ligands were able to induce IL-23p19 expression and IL-23 production in DCs (111). Moreover, IFN- γ and LPS synergize to induce IL-12 and IL-23 expression in murine and human myeloid-derived DCs and monocytes/macrophages (111, 117, 143). The signalling pathways regulating IL-12p40 expression in LPS-stimulated monocytic cells have been identified (10-12, 107, 108, 144). However, very little is known about the regulation of IL-23 (109-112). LPS-induced IL-23p19 was negatively regulated by Rac1 through the NF- κ Bp65 transactivation-dependent and I κ B independent pathway in PMA-treated THP-1 macrophages and human DCs without affecting IL-12/23p40 induction (112). IL-23p19 expression was also regulated by c-rel in murine DCs stimulated with TLR-2, -3, -4, -6 and -9 agonists (109). Furthermore, deletion analysis of the IL-12p40 promoter showed that LPS-induced IL-12p40 production in THP-1 cells is regulated through the transcription factors AP-1 and NF- κ B via the activation of JNK MAPK (10). Studies that used the p38 MAPK inhibitor, SB203580, have shown that the activation of the p38 MAPK signaling pathway positively regulates IL-23p19 mRNA in LPS-induced microglia cells (51). IL-23p19 and IL-12p40 mRNA expression was regulated by the PI3K/Akt pathway activation, leading to NF-

κ B activation in *Francisella tularensis*-induced human monocytes (140). IL-23 production in human MDMs is negatively regulated by ribosomal S6 kinase 1 (S6K1) activation in response to *M. tuberculosis*. Mammalian rapamycin (mTOR)/S6K1, are downstream mediators of PI3K. The inhibition of this signaling pathway upregulated IL-12/23p40 and IL-23p19 mRNA, as well as IL-23 protein expression (86, 145). Moreover, PI3K pathway was shown to negatively regulate IL-12p40 protein production in a murine splenic DC (146).

Taken together, these results show that TLR ligands can induce IL-23 expression and this is regulated through the MAPK and PI3K signaling pathways through MyD88, IRF and NF- κ B activation. However, little information is available regarding the mechanisms involved in IL-23 regulation of human myeloid cells stimulated with IFN- γ /LPS.

Signaling pathways involved in IL-27 regulation

The IL-27 cytokine is induced in response to a variety of stimuli, such as TLR-3, -4, -7/8, -9, CD40, IL-1 β and IFNR agonists (27, 147-149). Upon binding to its receptor, IL-27 activates the Jak/STAT pathways, in particular JAK-1, JAK-2, TYK-2, STAT-1, -2, -3, -4 -5 (66, 149-151). IL-27 induces activation of Th1 transcription factor, T-bet and is responsible for the upregulation of IL-12 receptor β 2. This signaling cascade is suppressed in STAT-1-deficient murine models (151).

Monocytes/macrophages and DCs stimulated with LPS can produce significant levels of IL-27 subunits (26, 84). Rat splenocytes that were treated with heat-killed *M. tuberculosis* showed an upregulation of IL-27p28 and IL-27EBI3 mRNA expression (152). In LPS and *E. coli*-stimulated bone marrow-derived DCs IL-27p28 gene expression was upregulated (153). TLR3 and 7 ligands were shown to activate JNK MAPK signaling pathway and induce IL-27p28 mRNA expression in TMEV-stimulated RAW264.7 cells, a murine macrophage cell

line (148). Bone marrow-derived macrophages were stimulated with *S. enteritidis* or LPS and IL-27 expression was induced through a TLR4/MyD88-mediated signaling pathway (128)(147). IL-27EBI3 mRNA expression was upregulated via TLR-2,-4,-9, MyD88 and NF- κ B activation in murine splenic DCs (154). Various TLR ligands such as LPS, R848 and CpG were able to induce IL-27p28 through the activation of IRF3 (155). In human MDMs, TLR3,-4 and -7/8 agonists expression of IL-27p28 and IL-27EBI3 gene expression was regulated through IRF1 and was inhibited using neutralizing antibodies against IFN- α (156). IFN- γ is produced by T and NK cells and plays a critical role in mounting effective immune responses against tumours and intracellular pathogens (157). Although IFN- γ -induced enhancement of IL-12 production is well established (113, 115, 158), its role in IL-27 production is poorly understood. Recently, IFN- γ was shown to induce IL-27 production in murine DCs. Murugaiyan *et al.* identified a new pathway by which IFN- γ may limit IL-17-mediated inflammation through differential regulation of osteopontin and IL-27 in dendritic cells (159). Monocytes/macrophages and dendritic cells can also be activated by IFN- γ to produce IL-12 family of cytokines, including IL-27 (26, 115, 159).

Taken together, these results show that TLR ligands can induce IL-27 expression and this is regulated through the MAPK and PI3K signaling pathways through MyD88, IRF1 and 3. However, little information is available regarding the mechanisms involved in IL-27 regulation of human myeloid cells stimulated with IFN- γ /LPS.

Interactions between the MAPK and PI3K signaling pathways

The PI3K and MAPK pathways are intensely studied due their critical involvement in regulating specific immune responses. Studies have implicated the PI3K/AKT pathway in the negative regulation of NF- κ B activation in LPS-stimulated THP-1 cells (179)(180).

However, others have shown that PI3K positively regulates NF- κ B in Hep2G cells, 3T3 fibroblasts, and human monocytes (181)(182). Knockdown models of PI3K/Akt have shown that lack of PI3K/Akt inhibits LPS-induced JNK activation without affecting ERK or p38 MAPK activation in murine MDMs and DCs (27). However, constitutive activation of Akt positively regulates NF- κ B downstream of p38 MAPK activation (183). p38 MAPK pathway can also negatively regulate ERK MAPK/ NF- κ B-dependent increases in pro-asthmatic symptoms, downstream of TLR-4 signaling (184). Heinrichsdorff et al, have shown that p38 MAPK in conjunction with the NF- κ B pathway can protect hepatocytes from TNF-induced death by inhibiting JNK MAPK activation in murine models (185).

In summary, MAPK signalling pathways, JNK, p38 and ERK were shown to be involved in LPS-induced IL-23p19 gene expression in murine DCs and macrophages (142). IFN- γ and LPS can synergize in order to induce IL-12 and IL-23 expression in murine and human myeloid-derived DCs and monocytes/macrophages (111, 117, 143). IL-23p19 was negatively regulated by Rac1 through the NF- κ Bp65 transactivation-dependent and I κ B independent pathway in PMA-treated THP-1 macrophages and human DCs in response to LPS stimulation (112). The p38 MAPK inhibitor, SB203580, have shown that the activation of the p38 MAPK signaling pathway positively regulates IL-23p19 mRNA in microglia cells prior to LPS stimulation (51). In LPS-stimulated bone marrow-derived DCs IL-27p28 gene expression was upregulated (153). Various TLR ligands such as LPS, R848 and CpG were able to induce IL-27p28 through the activation of IRF3 (155). Furthermore, IFN- γ was shown to induce IL-27 production in murine DCs. IFN- γ may limit IL-17-mediated inflammation through differential regulation of osteopontin and IL-27 in dendritic cells (159). Monocytes/macrophages and dendritic cells can also be activated by IFN- γ to produce IL-12 family of cytokines, including IL-27 (26, 115, 159). Taken together, these studies

show that there is a significant amount of cross-talk between the PI3K, MAPK and NF- κ B pathways. The activation of these pathways can regulate various genes, contributing to the tight regulation of immune responses. Furthermore, these signaling pathways have been implicated in the signaling of IL-23 and IL-27, giving another layer of complexity to elucidating the exact pathways that regulate their expression.

Rationale

The IL-12 family of cytokines plays a critical role in coordinating immune responses by bridging the innate and adaptive branches of the immune system (19, 33) and regulating host defenses against invading pathogens, such as *Francisella tularensis* (83), *Salmonella enteritidis* (84), *Bordetella pertussis* (85), *Mycobacterium tuberculosis* (86), Theiler's murine encephalomyelitis virus (TMEV) (87), Sendai virus (88), Hepatitis B (89) and cancer (Engel and Neurath, 2010). The importance of this family of cytokines is further underscored by its role in pathogenesis in a number of autoimmune disorders including experimental autoimmune encephalomyelitis, multiple sclerosis, psoriasis, colitis, Crohn's disease, rheumatoid arthritis (40-47). For these reasons, it is important to fully understand the mechanism regulating production of IL-12, IL-23 and IL-27, particularly in myeloid cells. IL-12, the canonical member of this family, has been extensively studied (4) (3, 23). However, very little is known about the regulation and induction of the other members of this family, particularly IL-23 and IL-27.

Monocytes/macrophages are professional APCs and important sources of IL-12 family of cytokines (3, 23). Previous studies have uncovered a complex mechanism involved in the induction of the subunits of these heterodimeric cytokines in response to different ligands in myeloid cells (3, 25, 26). These studies have also indicated engagement of multiple signaling pathways regulating the expression of IL-12 family of cytokines subunits, IL-12p40, IL-12p35, IL-23p19, IL-27p28 and EBI3. Moreover, certain studies have also indicated that different ligands may induce distinct members the IL-12 family of cytokines by engaging different signaling pathways in myeloid cell lineages (24), suggesting that IL-

12 may be produced in different myeloid cells by employing a variety of cell signaling pathways.

All members of the IL-12 family of cytokines are heterodimers with subunits that may be shared, but are differentially regulated (5, 6, 8). The production of these subunits may be induced by different stimuli and these stimuli may engage different signaling pathways which may result in different levels of IL-12 family production levels. This complexity presents great challenges in fully understanding the regulation of this important group of cytokines. This complexity may be further compounded by different outcomes in different myeloid cells. For this reason it is necessary to study the regulation of the IL-12 cytokine family members in different myeloid cell types. I have chosen human primary monocytes and monocyte-derived macrophages to study the regulation of IL-23 production as these cells are important sources of these cytokines and play a key role in innate and adaptive immune responses. I also employed THP-1 promonocytic cell line as a model system to confirm the results obtained with primary human monocytes and monocyte-derived macrophages. I also employed two stimuli IFN- γ and LPS, since both are strong inducers of IL-12 family cytokines. Previous studies have demonstrated that priming myeloid cells with IFN- γ prior to LPS stimulation resulted in increased levels of cytokine production (93). However, it is not known what mechanisms govern this priming phenomenon. One can envisage that different signaling pathways are engaged in this regulation, highlighting another layer of complexity to studying the regulation of the IL-12 family of cytokines.

Hypothesis: IL-12, IL-23 and IL-27 production is differentially regulated by IFN- γ and LPS activation by distinct signaling pathways in human primary monocytes, MDMs and THP-1 promonocytic cell line.

Objectives:

Specific Aim 1 Regulation of IFN- γ and LPS-induced IL-23 in monocytic cells

- 1.1 IFN- γ -induced IL-23 production and its regulation in primary human monocytes
- 1.2 LPS-induced IL-23 production and its regulation in THP-1 promonocytic cells
- 1.3 IFN- γ /LPS-induced IL-23 production and its regulation in human monocyte-derived macrophages

Specific Aim 2 Regulation of IFN- γ and LPS-induced IL-27 in monocytic cells

- 2.1 IFN- γ -induced IL-27 and IL-27p28 expression are differentially regulated through JNK MAPK and PI3K pathways, independent of JAK/STAT in human monocytic cells
- 2.2 IFN- γ -induced IL-27 and IL-27p28 expression are differentially regulated through JNK, p38 MAPK and PI3K pathways in THP-1 cells and MDMs
- 2.3 mRNA-protein inconsistency in response to IFN- γ /LPS in human MDMs

Chapter 2 Materials and Methods

Isolation of monocytes, cell culture and reagents

PBMCs were isolated from the whole blood of healthy donors by density gradient centrifugation using Ficoll Hypaque (Amersham Biosciences, Piscataway, NJ). Cells from at least three different donors was used for each experiment. In addition the cells, from the same donor were not used for subsequent experiments. The monocytes were then isolated by positive selection using CD14 Micro Beads human (Miltenyi Biotec, Bergisch Gladbach, Germany) by using the AutoMACS separator as per the manufacturer's directions. Monocytes were also negatively selected using the Monocyte Isolation Kit II (Miltenyi Biotec) (186). Untouched monocytes from PBMCs were isolated indirectly using magnetically-labeled biotin-conjugated antibodies against CD3, CD7, CD16, CD56, CD123 and Glycophorin A and anti-biotin MicroBeads. Negatively selected monocytes were then cultured with magnetically-labeled biotin-conjugated antibodies against CD14 (Miltenyi Biotec). The mononuclear cells obtained contained <5% CD3⁺ T cells and CD19⁺ B cells as determined by flow-cytometric analysis. The purified monocytes were rested by keeping them on ice for 30 min. Cells were cultured in IMDM (Sigma-Aldrich, St. Louis, Missouri) supplemented with 10% FBS (Invitrogen, Grand Island, New York), 100 units/ml penicillin, 100 µg/ml gentamicin, 10 mm HEPES, and 2 mm glutamine. Monocytes (1x10⁶/ml) were stimulated with IFN-γ (10 ng/ml) for 16 h. To determine the role of signaling pathways, monocytes (1x10⁶/ml) were incubated with increasing concentrations of various pharmacological inhibitors for 2 h prior to stimulation with IFN-γ. The pharmacological inhibitors specific for Jak/STAT (Jak inhibitor I, 10-100 nM), extracellular signal-regulated

kinase (ERK), (PD98059, 5-50 μ M), p38 MAPK (SB203580, 5-50 μ M), PI3K (LY294002, 5-50 μ M) were purchased from Calbiochem (Calbiochem-Merck, Darmstadt, Germany) whereas inhibitors specific for JNK (SP600125, 5-50 μ M) were purchased from BIOMOL (Plymouth Meeting, PA) and Sigma-Aldrich respectively. Monocytes exposed to the signalling pathway inhibitors for 24 h were >95% viable by flow cytometry.

Monocyte-derived macrophages (MDMs) were produced by adhering 5×10^6 PBMCs per well for 3 h, on a 12-well multidish (Thermo Scientific, Rochester, NY) in serum-free media. After 3 h, cells were washed three times with serum-free media, after which they were cultured for 6 days in complete media with M-CSF (10ng/ μ l). Fresh complete media containing M-CSF was added every two days. Characterization of macrophages was determined by flow cytometry, where the MDMs were stained with phycoerythrin (PE)-conjugated anti-CD11a, -CD11b, -CD11c, -CD80, -CD83, -CD16 and HLA-DR (BD Biosciences, Franklin Lakes, NJ). Histograms were created using WinMDI version 2.8 software (J. Trotter, Scriptts Institute, San Diego, CA).

THP-1, a promonocytic cell line derived from a human acute lymphocytic leukemia patient, was obtained from the American Type Culture Collection (Manassas, VA). Lipopolysaccharide (LPS) derived from *E. coli* 0111:B4 (Sigma-Aldrich Canada Ltd., Oakville, ON, Canada). All other chemicals used for Western blotting were obtained from Bio-Rad (Hercules, California).

Cell stimulation and collection of supernatants

Cells were stimulated with IFN- γ (10 ng/ml, 4 or 16 h) or with IFN- γ for 16 h followed by LPS (1 μ g/ml, 4 h) for quantification of mRNA by relative quantitative real-time PCR. Cells were also stimulated with IFN- γ (10 ng/ml, 16 h) or with IFN- γ and LPS (1 μ g/ml, 16 and 24 h, respectively), for quantification of protein secretion in the culture supernatants by ELISA.

In order to determine the role of signaling pathways, cells (1×10^6 /ml) were incubated with increasing concentrations of various pharmacological inhibitors for 2 h, prior to stimulation with either IFN- γ alone or stimulation of IFN- γ -primed cells with LPS. The pharmacological inhibitors specific for JAK/STAT (Jak inhibitor I, 10-100 nM), extracellular signal-regulated kinase-ERK (PD98059, 5-50 μ M), p38 MAPK (SB203580, 5-50 μ M), PI3K (LY294002, 5-50 μ M) were purchased from Calbiochem (Calbiochem-Merck, Darmstadt, Germany), whereas the inhibitor specific for JNK (SP600125, 5-50 μ M) was purchased from BIOMOL (Plymouth Meeting, PA). Calcium signaling inhibitor, ethylene glycol tetraacetic acid (EGTA, 2-10 mM) was purchased from Sigma-Aldrich. Cells exposed to the signaling pathway inhibitors for 24 h were >95% viable by flow cytometry. These inhibitors were dissolved in DMSO (0.1%) to make a stock concentration of 20mM.

Inhibitor	Concentrations Used	Target	Generic Name	Formula
PD98059	5-50 μ M	ERK MAPK	2'-amino-3'-methoxyflavone	C ₁₆ H ₁₃ NO ₃
SP600125	5-50 μ M	JNK MAPK	Anthra[1,9-cd]pyrazol-6(2H)-one	C ₁₄ H ₈ N ₂ O
SB203580	5-50 μ M	p38 MAPK	4-(4-Fluorophenyl)-2-(4-hydroxyphenyl)-5-(4-pyridyl)1H-imidazole	C ₂₀ H ₁₄ FN ₃ O
LY294002	5-50 μ M	PI3K	2-(4-morpholinyl)-8-phenyl-4H-1-benzopyran-4-one	C ₁₉ H ₁₇ NO ₃
EGTA	2-10mM	Calcium chelator	Ethyleneglycol-bis(β -aminoethyl)-N,N,N',N'-tertaacetic acid	C ₁₄ H ₂₄ N ₂ O ₁₀
JAK Inhibitor-I	10-100nM	JAK kinases	2-(1,1-dimethylethyl)-9-fluro-3,6-dihydro-7H-benz[h]-imidaz[4,5-f]isoquinolin-7-one	C ₁₈ H ₁₆ FN ₃ O

Table 1 List of signaling inhibitors used

In order to determine whether IL-27 expression in human MDMs is regulated through the lysosomal degradation pathway, cells were treated for 2h with chloroquine diphosphate salt at a 25 μ M concentration (Sigma-Aldrich). Furthermore, in order to determine whether IL-27 expression in human MDMs is regulated through the proteosomal degradation pathway, cells were treated for 2h with clasto-lactacystin β -lactone at a 5 μ M concentration (Calbiochem) in DMSO.

Reverse-transcription-polymerase chain reaction (RT-PCR)

mRNA expression were analyzed by quantitative reverse transcription-polymerase chain reaction (qRT-PCR) using random primers (Applied Biosystems, Foster City, CA) and the one-step quantitative RT-PCR system (Applied Biosystems). Total RNA was extracted from cells using the RNeasy kit (QIAGEN Inc., Mississauga, Canada). Samples were lysed in the lysis buffer provided in the kit and then homogenized. Ethanol was added to the lysate

to provide ideal binding conditions. Pure, concentrated total mRNA was eluted in 50µl of distilled water. The cDNA was generated from 1 µg total RNA by using the Qiagen kit according to the manufacturer's instructions (Applied Biosystems). Reverse-transcription PCR was performed in 0.2ml PCR tubes under the following conditions: 10 min at 25°C, 2 hr at 37 °C and 5 min at 85 °C, hold at 4⁰C.

Measurement of mRNA by relative quantitative real-time PCR

The expression level of each mRNA was quantitatively analyzed by a 7500 Real-Time PCR System (Applied Biosystems) with the cDNA prepared as described above and TaqMan Universal Master Mix (Applied Biosystems). The specific primers for human IL-23p19, IL-12/23p40, IL-12p35, IL-27p28, EBI3, TTP and β-actin were purchased from Applied Biosystems. Real-time PCR was performed in 96-well microtiter plates under the following conditions: 2 min at 50 °C, 10 min at 95 °C and 40 cycles of 15 s at 95 °C and 1 min at 60 °C. The primers for IL-23p19 (Hs00373324_m1), IL-12p40 (Hs00233688_m1), IL-27p28 (Hs00377366_m1), IL-27EBI3 (Hs00194957_m1), TTP (Hs00185658_m1) and β-actin (Hs99999903_m1) were purchased from Applied Biosystems. The expression levels of mRNA quantified by TaqMan Gene Expression Assay were shown as the ratio of that of β-actin, which was determined with human β-actin control reagent (Applied Biosystems), by calculation of cycle threshold (Ct) values in amplification plots. Beta-actin was used as endogenous control. To control for cross-contamination, a sample consisting of distilled water was also tested. All the primers were labeled at their 3' terminus with a reporter fluorophore 6-carboxyfluorescein (FAM). The expression levels of the IL-12 family mRNA quantified by TaqMan Gene Expression Assay were shown as the ratio of that of β-actin,

which was determined with human β -actin control reagent (Applied Biosystems), by calculation of cycle threshold (Ct) values in amplification plots.

Target gene	Sequence 5' – 3'
IL-23p19	GTGGGACACATGGATCTAAGAGAAG
IL-27p28	GCCGCCTCTCTGACCCGGCGGTCT
EBI3	GCGCGCTTCCACCGGGTGGGGCCCA
IL-12p40	CAAAAGCAGCAGAGGCTCTTCTGAC
TTP	GCGGAATTCTCTCTGCCATCTACGAGAGCCTC
β-actin	GCCTCGCCTTTGCCGATCCGCCGCC

Table 2 List of target gene primers used and their sequences (Applied Biosystems)

Quantification of IL-23, IL-27 and IL-12/23p40 proteins by ELISA

IL-12/23p40 protein in the culture supernatants was quantified by ELISA using two different monoclonal antibodies that recognize distinct epitopes as described previously (10). ELISA plates (Thermo Fisher Scientific, Nunc, Waltham, MA) were coated overnight at 4°C with anti-human IL-12p40 capture monoclonal antibody (Invitrogen, Camarillo, California; 1 μ g/ml). IL-12/23p40 was detected using biotinylated anti-IL-12/23p40 monoclonal antibody (Invitrogen, Camarillo, California, 350ng/ml). Streptavidin-peroxidase (Jackson ImmunoResearch, West Grove, PA) was used at a final dilution of 1/1000. The color reaction was developed by *o*-phenylenediamine (Sigma-Aldrich) and hydrogen peroxide. Recombinant IL-12/23p40 (R&D Systems) was used as a standard. The IL-12p40 capture antibody measures all p40, regardless of whether it is dimerized with p19 or p35.

IL-23 production was quantified using a commercial ELISA kit (eBiosciences, San Diego, California). ELISA plates (Thermo Fisher Scientific) were coated overnight at 4°C with anti-human IL-23 capture antibody (eBiosciences) as per the manufacturer's instructions. IL-23 was detected using biotin-conjugated anti-human IL-23 (eBiosciences) antibodies. The color reaction was developed using TMB Super Sensitive One Component

HRP Microwell Substrate (SurModics In Vitro Diagnostic Products, Eden Prairie, Minnesota) by using horseradish peroxidase-conjugated avidin provided in the kit.

IL-27 protein in the culture supernatants was quantified by ELISA using two different monoclonal antibodies that recognize distinct epitopes (R&D Systems, Inc., Minneapolis, MN USA). ELISA plates (Thermo Fisher Scientific, Nunc, Waltham, MA) were coated overnight at room temperature with anti-human IL-27 capture monoclonal antibody (R&D Systems, Inc., 0.4 µg/ml). IL-27 was detected using biotinylated anti-IL-27 monoclonal antibody (R&D Systems, Inc., 200 ng/ml). Streptavidin-peroxidase (R&D Systems, Inc.) was used at a final dilution of 1/200. The color reaction was developed using TMB Super Sensitive One Component HRP Microwell Substrate (SurModics In Vitro Diagnostic Products, Eden Prairie, Minnesota) by using horseradish peroxidase-conjugated avidin provided in the kit. Recombinant IL-27 (R&D Systems) was used as a standard. Negatively selected monocytes and negatively selected monocytes cultured with anti-CD14 beads were also stimulated under the same conditions (IFN-γ 10ng/ml for 16 hr, 1×10^6 cells).

Western blot analysis

Cells (1×10^6 /ml) were treated with increasing concentrations of each signalling pathway inhibitor for 2 h, followed by IFN-γ (10 ng/ml) stimulation for 15 min or LPS (1 µg/ml) for 30 min, respectively. Cell lysates were collected and Jak, Akt, ERK, JNK and p38MAPK phosphorylation was determined by Western blot analysis as previously described (10). Cell-associated IL-27p28 and EBI3 levels were determined after 24 h of LPS (1 µg/ml) stimulation. Cell lysates were prepared by treating the cell pellets at 4°C for 30-45 min with lysis buffer (50 mM HEPES pH 7.5, 150 mM NaCl, 10% glycerol, 1% Triton X-

100, 1.5 mM MgCl₂, 100 mM NaF, 100 mM sodium orthovanadate, and 1 mM EGTA pH 7.7), followed by centrifugation for 30 min at 14000 x g at 4°C. Total cell proteins were subjected to 10% polyacrylamide SDS-PAGE and the proteins were subsequently transferred onto polyvinylidene difluoride (PVDF) membranes (BioRad). The membranes were probed with either rabbit anti-human-phospho-p38 (Thr180/Tyr182; New England Biolabs, Mississauga, Ontario, Canada), mouse anti-human-phospho-ERK MAPKs (Thr202/Tyr204) (Santa Cruz Biotechnologies, Inc., Santa Cruz, CA), mouse anti-human phospho-JNK (Thr183/Tyr185; Santa Cruz Biotechnologies, Inc.), rabbit anti-human-phospho-Akt (Ser473; Cell Signalling Technology) antibodies followed by detection with horseradish peroxidase conjugated goat anti-rabbit or goat anti-mouse polyclonal antibodies (Bio-Rad). The membranes were stripped (stripping buffer: 62.5 mM Tris-HCl, pH 6.7, 100 mM 2ME, 2% SDS and 710 µl DTT) for 30 min and re-probed with rabbit polyclonal antibodies specific for the un-phosphorylated forms of either ERK, p38, JNK MAPKs (Santa Cruz) or Akt and GAPDH (Cell Signalling Technology). Cell-associated IL-27p28 and EBI3 levels were visualized using polyclonal goat anti-human IL-27 (R&D Systems) reconstituted as per manufacturer's instructions. All immunoblots were visualized by enhanced chemiluminescence (ECL, Amersham, Baie d'Urfe, PQ, Canada). Antibodies were diluted 1:1000 in 2% bovine serum albumin (MP Biomedicals, Solon, OH, United States).

Cell surface staining measured by flow cytometry

Anti-human mouse antibodies used for flow cytometry were phycoerythrin (PE)-labeled monoclonal IFN- γ R1 and monoclonal TLR4 (R&D Systems). Monocytes (1×10^6 cells) were incubated with either anti-human TLR4-PE, or anti-human IFNGR1-PE at 4°C

for 30 min, then washed with PBS. The cell surface expression of IFN- γ R1 and TLR4 was analyzed by flow cytometry using BD FACSCanto software (BD Biosciences, San Jose, CA, USA). Histograms were done using Windows Multiple Document Interface for Flow Cytometry (WinMDI 2.5 – developer Joe Trotter).

In order to characterize the phenotype of monocyte-derived macrophages, PBMCs (5×10^6 cells) were plated and monocytes were differentiated into macrophages with M-CSF over 6 days. Cells were washed and stained with PE-conjugated antibodies for 15 minutes. Surface expression of CD83, CD80, CD16, CD11a, CD11b, CD11c and HLA-DR (R&D Systems) was assessed by flow cytometry. MDMs were washed and stained with PE-conjugated mouse monoclonal anti-human WSX-1 and Per-CP-conjugated mouse monoclonal anti-human gp130 for 15 minutes, both antibodies obtained from R&D Systems. Surface expression of WSX-1 and gp130 was assessed by flow cytometry.

Neutralization assay of IFN- γ R1/CD119

Monocytes (1×10^6) were incubated with goat anti-human IFN- γ R1/CD119 (10 μ g/ml; IgG; R&D Systems) in the presence of IFN- γ stimulation. As a control, monocytes were also incubated with equal quantities of an isotype-matched anti-goat IgG antibody (R&D systems) in the presence of IFN- γ . Cells were cultured for 16 hr following which supernatants were analyzed for IL-23 production by ELISA as described above.

Transfection of small interfering RNA (siRNA)

Transfection of JNK, p38 siRNA, and p85 PI3K siRNA were performed in the promonocytic cell line THP-1. Cells were seeded in 12 well plates at a concentration of 2.5×10^5 cells/ml in serum-free IMDM media and were transfected with either 1 μ g of small

interfering RNAs specific for JNK, p38, PI3Kp85 or scrambled control siRNA as described by the manufacturer (Santa Cruz, Santa Cruz, CA). Cells were transfected with siRNA for JNK 1 and 2, p38 α , β and γ , or PI3K p85 α and β and nonspecific control pool (siRNA control) using Santa Cruz transfection reagents as per the manufacturer's instructions (Santa Cruz Biotechnologies, Inc.). Briefly, cells were washed once in sterile PBS and then resuspended in serum-free IMDM media. Following transfection, cells were stimulated with LPS (1 μ g/ml, 4 h) for Real-Time PCR and for 30 min for Western blotting for JNK, p38, or p85 PI3K. The supernatants were collected after 24 hours of LPS stimulation (1 μ g/ml) to be analyzed for cytokine expression by ELISA.

Statistical analysis

Means were compared using the two-tailed Student's t test. Results are expressed as mean \pm SEM. All experiments were repeated at least three times and sample sizes are provided in the figure legends.

Ethics Statement

Informed consent was given in writing by all participants based on the study protocol which was approved by the Research Ethics Boards of the Research Institute, Children's Hospital of Eastern Ontario and the Ottawa Hospital Research Institute, University of Ottawa, Ottawa, Ontario, Canada.

Results

Chapter 3 Regulation of IFN- γ and LPS-induced IL-23 in myeloid cells

3.1 IFN- γ -induced IL-23 production and its regulation in primary human monocytes

IL-23 induces differentiation and proliferation of Th1 cells by promoting IFN- γ production by CD4⁺ memory T cells (19, 38). The key feature of IL-23 is its ability to induce generation of Th17 cells and IL-17 production (39, 40). The IL-23-Th17 axis plays a key role in the induction of inflammatory cytokines and pathogenesis of autoimmune disorders (41-44).

Stimulation of various TLRs such as TLR2, TLR4 and TLR7/8 induce IL-23p19 expression and IL-23 production in DCs (111). Moreover, IFN- γ and LPS synergize to induce IL-12 and IL-23 expression in murine and human myeloid-derived DCs and monocytes/macrophages (108, 110, 141). Interestingly, IFN- γ has also been shown to negatively regulate LPS-induced IL-23 production in murine macrophages (187). Whether IFN- γ alone can induce the production of IL-23, IL-12p40 or IL-23p19, in human monocytes remains unknown.

IFN- γ mediates its biological effects primarily via the activation of the Jak/STAT pathway (103). IFN- γ has also been shown to activate MAPKs (101), PI3K (105) and Src kinases (106) in a STAT-1-independent manner (103). The signalling pathways regulating IL-12p40 expression in LPS-stimulated monocytic cells have been studied within the context of IL-12 regulation (10-12, 107, 108, 144). However, very little is known about the regulation of IL-23 in LPS and IFN- γ -stimulated monocytic cells (108, 116, 118, 142). My results show for the first time that IFN- γ induced the production of IL-12p40 and IL-23 in

primary human monocytes isolated by positive selection through the use of anti-CD14 antibodies conjugated with microbeads and not in negatively selected monocytes. My data have also demonstrated a differential positive regulation of IL-12p40 and IL-23 by p38 MAPK. These cytokines were negatively regulated by Jak/STAT, c-Jun N-terminal kinases (JNK) MAPK and PI3K pathways in CD14-activated primary human monocytes in response to stimulation with IFN- γ .

IFN- γ induces the expression of IL-12p40 and IL-23 in positively selected but not in negatively selected human monocytes

IFN- γ is a natural stimulant which is known to prime murine monocytic cells to produce IL-12 in response to LPS (117). Therefore, I first determined whether monocytes isolated by negative or positive selection respond in a differential manner to IFN- γ by producing IL-23 and its subunits. IFN- γ stimulation of positively selected monocytes induce in a time-dependent manner, the expression of IL-23p19 and IL-12/23p40 mRNA (Fig 3.1.1A), with the highest production at 16h. IFN- γ -stimulation of monocytic cells enhanced the production of IL-23 and IL-12/23p40 proteins (Fig 3.1.1B) compared to unstimulated cells. These positively selected monocytes secreted high basal levels of IL-12/23p40 and IL-23 proteins. In contrast to monocytes selected through anti-CD14 beads, stimulation of negatively selected monocytes with IFN- γ failed to induce IL-12/23p40 and IL-23 proteins. At the same time, negatively selected monocytes produced relatively low basal levels of IL-12/23p40 and IL-23 proteins (Fig 3.1.2A and B).

Fig 3.1.1 IFN- γ induces IL-23 and IL-12p40 expression in positively selected human monocytes. (A) Positively selected primary human monocytes (1×10^6 /ml) were stimulated with IFN- γ (10 ng/ml, 4 h or 16 h; n=4). IL-23p19 and IL-12/23p40 mRNA expression were quantified by relative quantitative real-time PCR. (B). Positively selected human primary monocytes (1×10^6 /ml) were stimulated with IFN- γ (10 ng/ml, 16 h, n=22). IL-23 and IL-12/23p40 protein production was determined by ELISA. As a control, I have tested for presence of IL-12p70 cytokine using the IL-23 ELISA kit, ensuring that is no cross-reactivity in the ELISA kit between the two cytokines. The results are shown as mean \pm SEM, * $p < 0.05$; ** $p < 0.01$; *** $p < 0.001$; Unstim- unstimulated.

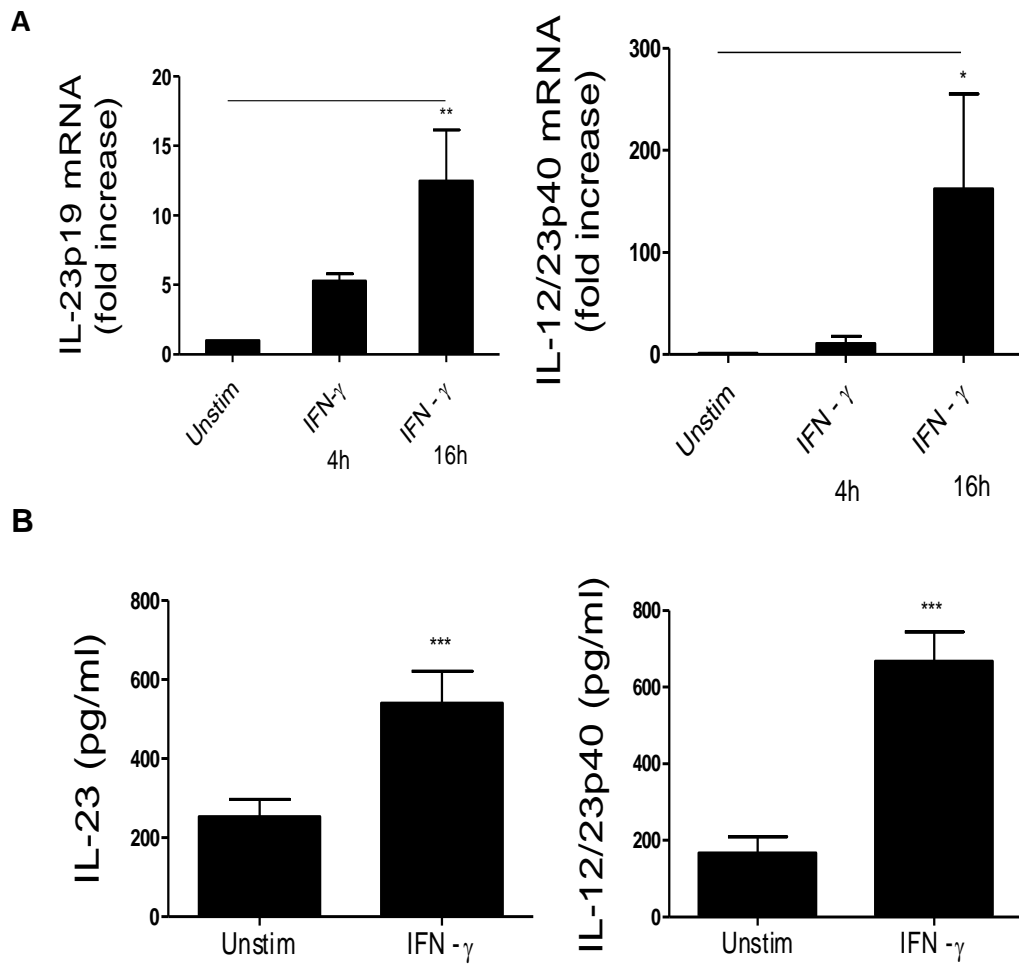

Figure 3.1.1

Fig. 3.1.2 IFN- γ stimulation of CD14-activated monocytes triggers IL-12p40 and IL-23 production. Untouched negatively selected monocytes (1×10^6 /ml) were stimulated with IFN- γ (10 ng/ml, 16 h, n=4). Negatively selected monocytes (1×10^6 /ml) were treated with anti-CD14 antibodies-conjugated beads at 4 C for 1 hr followed by stimulation with IFN- γ (10 ng/ml) for 16 h (n=4). IL-12/23p40 (A) and IL-23 (B) protein production was determined by ELISA. The results are shown as mean \pm SEM, * $p < 0.05$; Unstim- unstimulated.

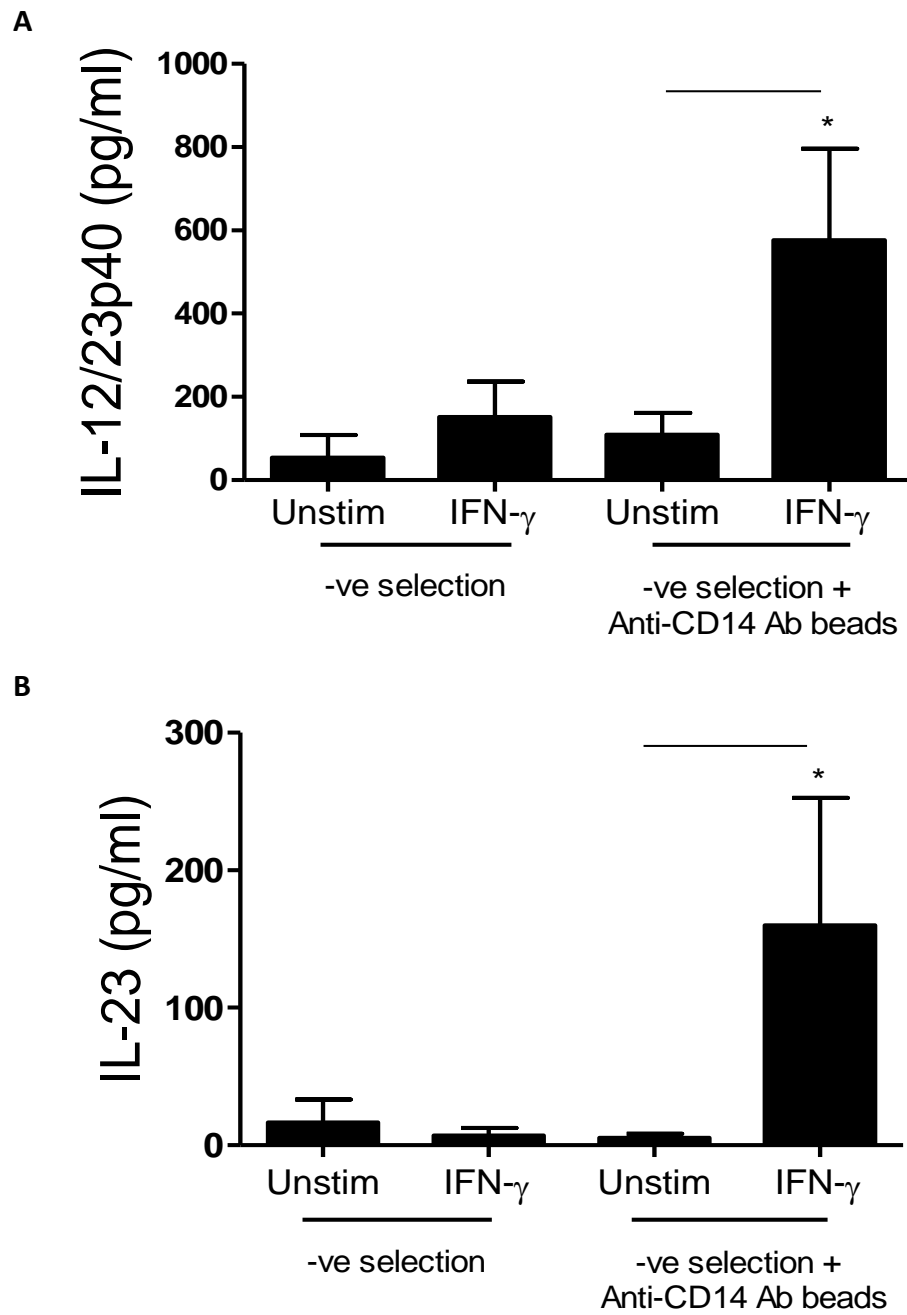

Figure 3.1.2

Since monocytes were isolated by positive selection through the usage of anti-CD14 antibodies coated beads, I hypothesized that IFN- γ -induced production of IL-12/23p40 and IL-23 proteins was due to prior stimulation of monocytes through CD14 receptors. Therefore, negatively selected monocytes were cultured with anti-CD14 antibody-coated beads followed by stimulation with IFN- γ . Interestingly, IFN- γ was able to induce significant production of IL-12/23p40 and IL-23 in these cells (Fig 3.1.2A and B). These results suggest that IFN- γ induces the expression of IL-12/23p40 and IL-23 proteins in cells activated through the CD14 receptors. To understand how CD14 engagement sensitizes monocytes to IFN- γ , I hypothesized that CD14 stimulation may induce the expression of IFN- γ receptors (IFNGR1/CD119). Therefore, I compared the expression of IFNGR1 on positively and negatively selected monocytes, as well as the negatively selected monocytes cultured *in vitro* with anti-CD14 beads. The results show that percentage of IFNGR1-expressing cells were significantly higher in monocytes selected via CD14 engagement compared to negatively selected cells (Fig 3.1.3A, column 1 versus column 2). The expression of IFNGR1 on negatively selected cells cultured with anti-CD14 beads was enhanced compared to the negatively selected cells (Fig 3.1.3A, column 2 versus column 3). A representative histogram showing IFNGR1 expression in positively, negatively selected and negatively selected cells cultured with anti-CD14 beads is shown (Fig 3.1.3A right panel). Thus, enhanced expression of IFNGR1 in response to CD14 activation may result in higher IL-23 production following IFN- γ stimulation.

To further demonstrate that upregulation of IFNGR1 leads to higher IFN- γ -induced IL-23 production, I blocked the IFNGR1 using anti-IFNGR1 antibodies. Treatment of positively selected monocytes with neutralizing anti-IFNGR1 antibody significantly

Fig 3.1.3 CD14 engagement sensitizes positively selected monocytes to IFN- γ stimulation by upregulating IFNGR1. (A) The unstimulated positively selected monocytes, negatively selected monocytes and negatively selected monocytes cultured with anti-CD14 beads from six different healthy individuals (1×10^6 /ml) were cultured in complete media followed by the analysis of IFNGR1 cell-surface expression by flow cytometry and represented as percentage of cells expression IFNGR1 in positively selected, negatively selected monocytes and negatively selected monocytes cultured with anti-CD14 beads is shown (right panels). (B) Positively selected monocytes (1×10^6 /ml) from six healthy donors were stimulated with IFN- γ (10 ng/ml, 16 h) in the presence of either isotype matched control antibodies or anti-IFNGR1 antibodies. IL-23 protein production was determined by ELISA. The results are shown as mean \pm SEM (n=4), * p < 0.05; ** p < 0.01; Unstim-unstimulated; +ve – positive, -ve – negative.

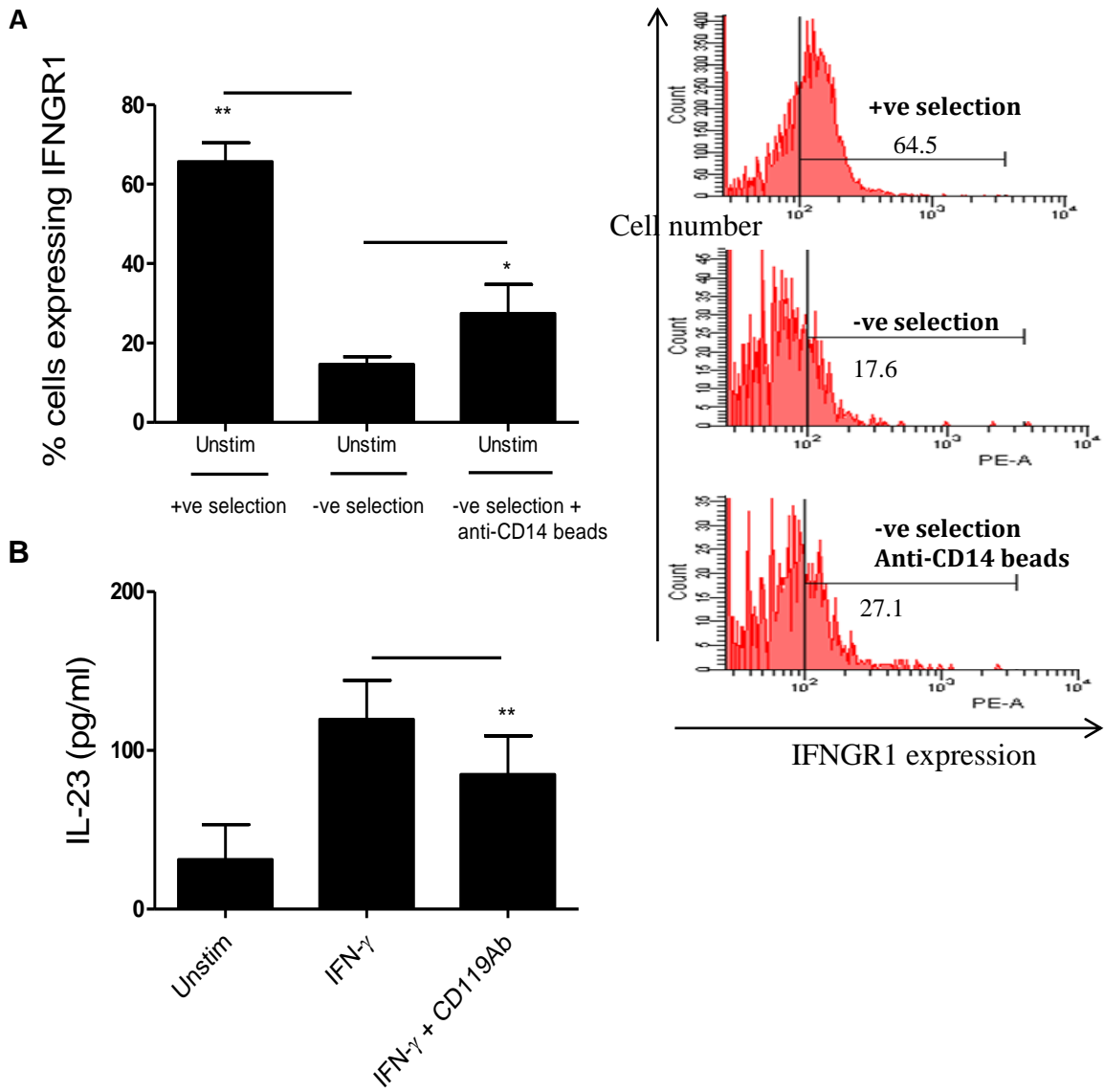

Figure 3.1.3

decreased IFN- γ -induced IL-23 production (Fig 3.1.3B) compared to the IFN- γ stimulated cells treated with an isotype-matched control antibody.

IFN- γ priming of monocytes and APCs has been shown to enhance their ability to produce IL-23 in response to a second stimulus such as LPS (143). Enhanced IFNGR1 expression on positively selected monocytes may also lead to enhanced IFN- γ -mediated expression of TLRs. Therefore, positively and negatively selected monocytes as well as negatively selected monocytes cultured with anti-CD14 beads were stimulated with IFN- γ for 16 hr followed by analyzing the expression of TLR-4 receptors by flow cytometry. The results show that IFN- γ induced significantly higher percentage of TLR-4 receptors-expressing cells on positively selected monocytes as well as negatively selected monocytes cultured with anti-CD14 beads compared to the negatively selected monocytes (Fig 3.1.4A). Next, I determined whether enhanced TLR-4 expression following IFN- γ priming of positively selected monocytes would result in enhanced IL-23 production following LPS stimulation. Results show that IFN- γ priming of positively selected monocytes significantly enhanced LPS-induced IL-23 production (Fig 3.1.4B). Subsequently, I focussed on understanding the mechanism underlying the regulation of IFN- γ -induced IL-23 production in positively selected monocytes.

The Jak/STAT pathway negatively regulates IL-12/23p40 protein and IL-23p19 mRNA expression but not IL-23 expression following IFN- γ stimulation.

IFN- γ mediates its effects primarily through the activation of Jak/STAT pathway (103). Therefore, the role of this pathway in regulating IFN- γ -induced IL-23 expression was investigated using Jak inhibitor-I which inhibits the Jak/STAT pathway. Monocytes pre-

Fig 3.1.4 Upregulated IFNGR1 on positively selected monocytes exhibit enhanced TLR-4 receptors following IFN- γ stimulation leading subsequently to enhanced LPS-induced IL-23 production. (A) The unstimulated positively selected monocytes, negatively selected monocytes and negatively selected monocytes cultured with anti-CD14 beads from six different healthy individuals (1×10^6 /ml) were stimulated with IFN- γ (10 ng/ml) for 16 hr followed by the analysis of TLR-4 receptors expression by flow cytometry and represented as a percentage of cells expression TLR-4 receptors (n=5). (B) Positively selected monocytes (1×10^6 /ml) were stimulated with IFN- γ (10 ng/ml, 16 h) or with IFN- γ (10 ng/ml, 16 h) and LPS (1 μ g/ml, 24 hr). IL-23 protein production was determined by ELISA (n=15). The results are shown as mean \pm SEM, * p < 0.05; ** p < 0.01; *** p < 0.001; Unstim-unstimulated.

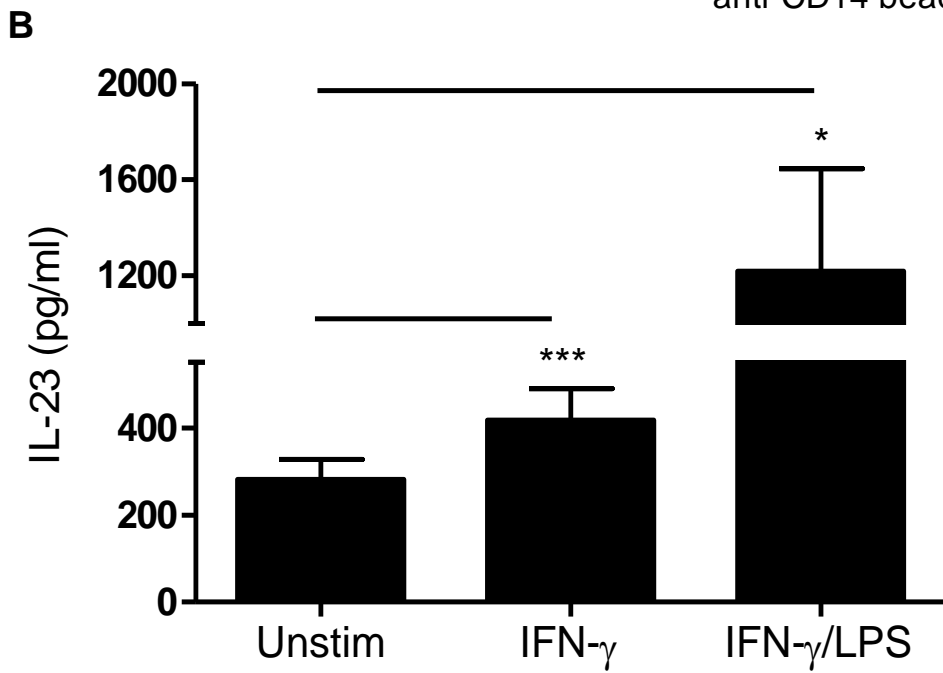
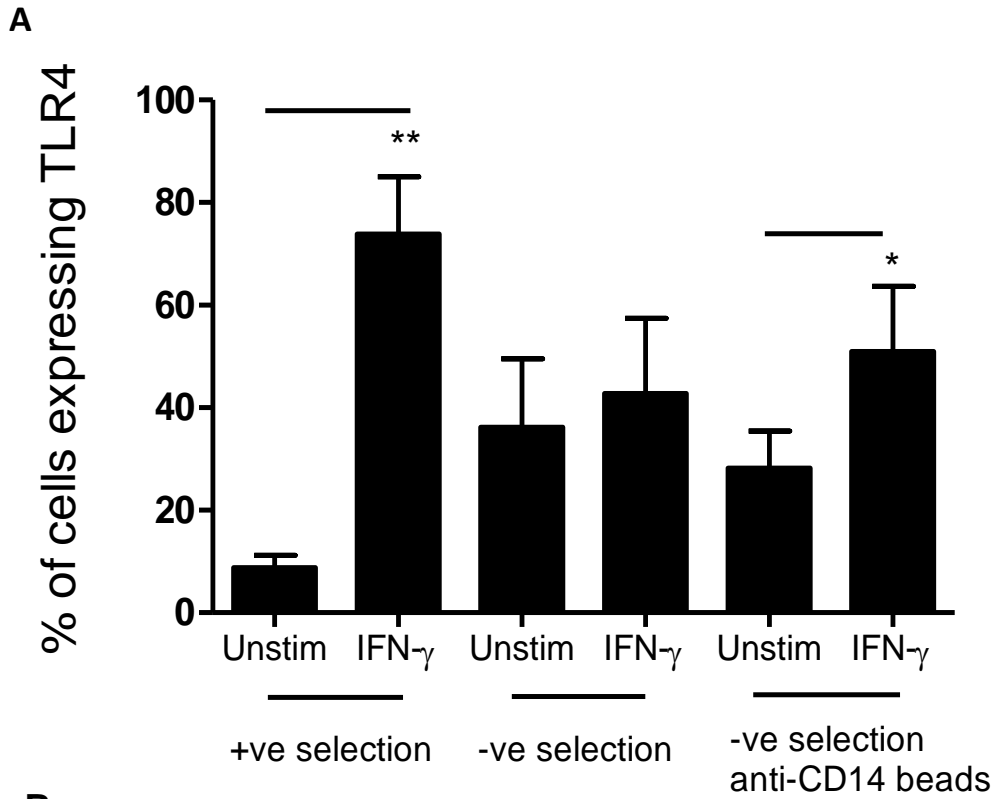

Figure 3.1.4

treated with Jak inhibitor-I were stimulated with IFN- γ and analyzed for STAT1 phosphorylation followed by measurement of IL-12/23p40 and IL-23 expression by relative quantitative real-time PCR (RQ-PCR) and ELISA. Cells pretreated with Jak inhibitor-I showed inhibition of STAT-1 phosphorylation in a dose-dependent manner (Fig 3.1.5A). The unphosphorylated form of the protein was used to demonstrate equal loading control in order to attribute the increased levels of phosphorylation observed to IFN- γ stimulation. Interestingly, IFN- γ stimulation of cells pretreated with Jak inhibitor-I significantly increased the expression of IL-23p19 mRNA and IL-12/23p40 proteins production in a dose-dependent manner (Fig 3.1.5B and 3.1.5C). The Jak inhibitor-I did not significantly enhance IL-23 protein expression in positively selected monocytes following stimulation with IFN- γ . However, a trend towards increased IL-23 production was observed in a dose-dependent manner (Fig 3.1.5D). It may be pointed out that similar concentrations of Jak inhibitor-I inhibited IL-4-induced CD44 expression in THP-1 cells ((data not shown and (188)), suggesting a specific effect of IFN- γ -Jak/STAT pathway in negative regulation of IL-23 production.

IL-23 expression in IFN- γ -stimulated monocytes is negatively regulated by the PI3K pathway

IL-23 has also been shown to be positively regulated by the PI3K pathway following infection of human monocytic cells with *Francisella tularensis* and *Mycobacterium tuberculosis* (86, 140). Therefore, I examined the role of PI3K signalling in the regulation of IL-23 expression in IFN- γ -stimulated monocytic cells by using a pharmacological PI3K inhibitor, LY294002. First, I demonstrated that pretreatment with LY294002 inhibited IFN- γ -induced Akt phosphorylation in monocytes (Fig 3.1.6A). Inhibition of PI3K in IFN- γ -stimulated monocytes significantly enhanced IL-23p19 mRNA expression (Fig. 3.1.6B), as

Fig 3.1.5 IFN- γ -induced IL-12p40 and IL-23 expression is negatively regulated by the JAK/STAT pathway (A). Positively selected monocytes (1×10^6 /ml) were treated with increasing concentrations of Jak inhibitor I (0-100 nM) for 2 h followed by IFN- γ (10 ng/ml) stimulation for 15 min. Cell pellets were harvested for determination of STAT-1 phosphorylation by Western blot analysis. The result shown is a representative of three independent experiments. (B-D) Monocytes (1×10^6 /ml) were treated with increasing concentrations of Jak inhibitor I (0-100 nM) for 2 h followed by stimulation with IFN- γ (10 ng/ml, 16 h) for quantification of IL-23p19 mRNA expression by RQ-PCR (n=3) (B) whereas IL-12/23p40 (n=6) (C) and IL-23 (n=5) (D) protein production was determined by ELISA. The results are shown as mean \pm SEM of 3-5 independent experiments, * p < 0.05; ** p < 0.01; *** p < 0.001; Unstim- unstimulated.

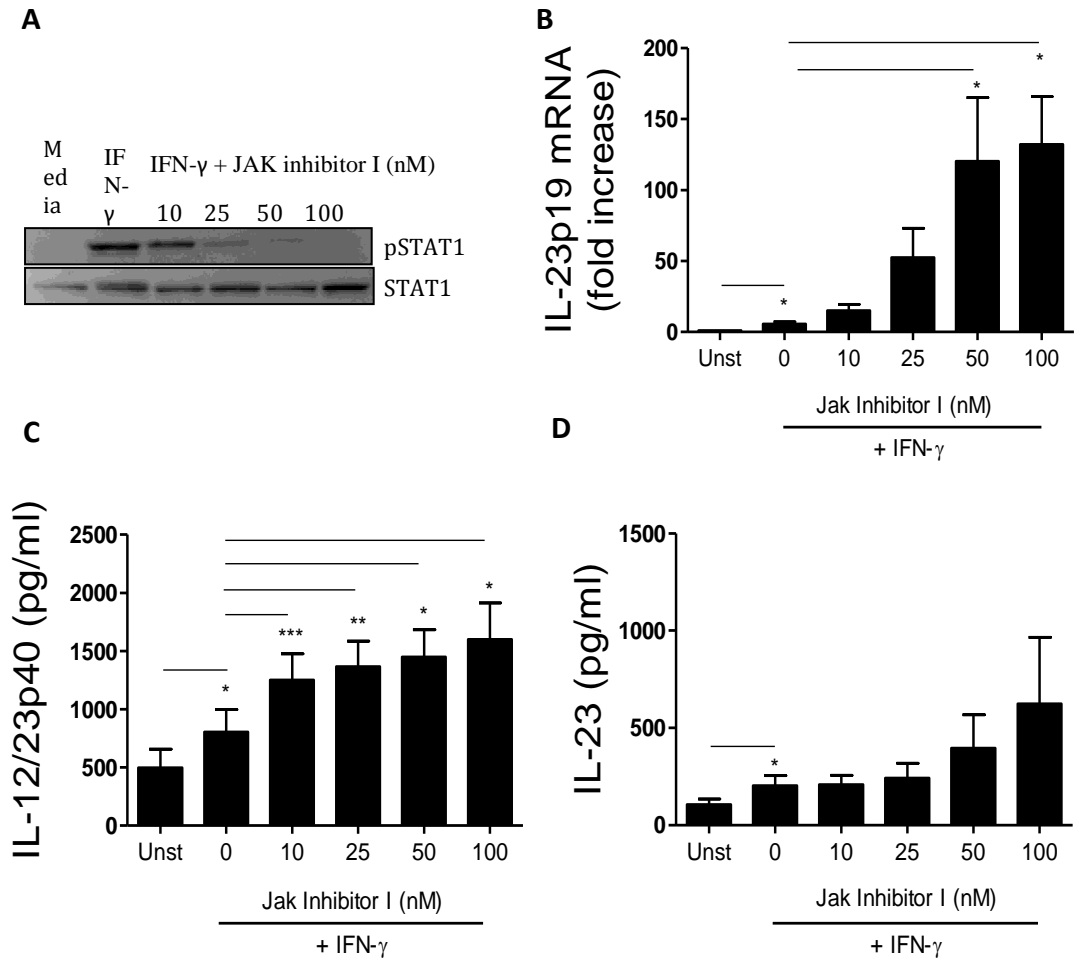

Figure 3.1.5

Fig. 3.1.6 IFN- γ -induced IL-23 expression is negatively regulated by the PI3K pathway. (A). Positively selected monocytes (1×10^6 /ml) were treated with increasing concentrations of the PI3K inhibitor LY294002 (0-50 μ M) for 2 h followed by IFN- γ (10 ng/ml) stimulation for 15 min. Cell pellets were analyzed for Akt phosphorylation by Western immunoblotting. The result shown is a representative of three independent experiments. (B-D): Monocytes were stimulated with IFN- γ (10 ng/ml, 16 h) for quantification of IL-23p19 mRNA expression by RQ-PCR (n=4) (B) and for determination of IL-23 (n=6) (C) and IL-12/23p40 (n=5) (D) protein production by ELISA. The results are shown as mean \pm SEM of 3 to 5 independent experiments, * p < 0.05; ** p < 0.01; Unstim- unstimulated.

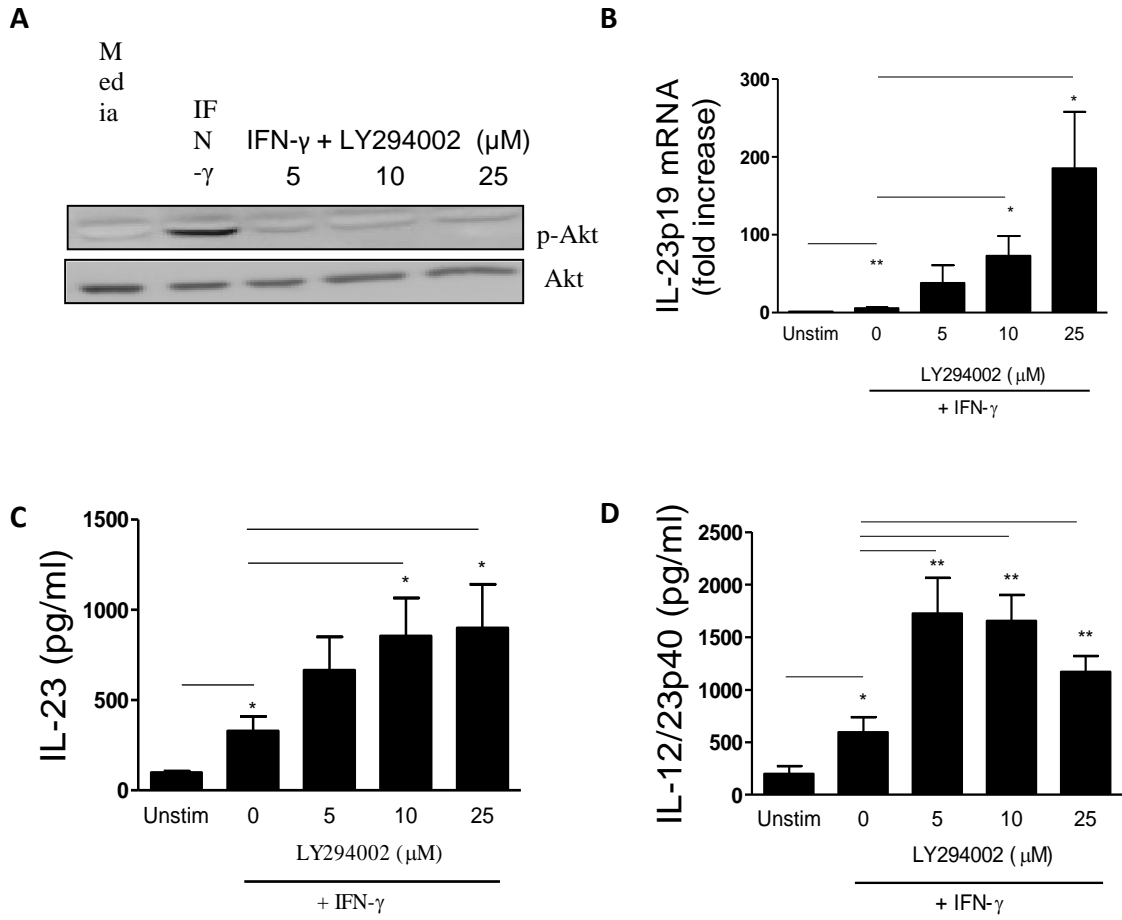

Figure 3.1.6

well as IL-12/23p40 and IL-23 protein production (Fig 3.1.6C, 3.1.6D). These results suggest that IL-12/23p40 and IL-23 expression is negatively regulated by the PI3K pathway in IFN- γ -stimulated primary monocytes isolated by positive selection.

IL-23 expression in IFN- γ -stimulated monocytes is positively regulated by p38 and negatively regulated by the JNK MAPK pathways

To understand the contribution of MAPKs to the regulation of IL-23p19, IL-12/23p40 and IL-23 expression in IFN- γ -stimulated monocytes, I employed inhibitors specific for p38 (SB203580), ERK (PD98059) and JNK (SP600125) MAPKs (10, 110, 111). JNK, p38 and ERK MAPK were phosphorylated in positively selected monocytes following stimulation with IFN- γ (Fig 3.1.7). MAPK were phosphorylated in positively selected monocytes following stimulation with IFN- γ . The specificity of different inhibitors was tested prior to starting the experiments. Cells pretreated with SB203580, PD98059 or SP600125 showed a significant dose-dependent decrease in phosphorylation of p38, ERK and JNK MAPKs, respectively, following IFN- γ stimulation (Fig 3.1.7A, B and C).

The inhibition of JNK resulted in a significant increase in IFN- γ -induced expression of IL-23p19 mRNA, and IL-12/23p40 and IL-23 protein levels (Fig 3.1.8A, B, C left panels). These results suggest that the JNK pathway negatively regulates IFN- γ -induced IL-12/23p40 and IL-23 production. Interestingly, although inhibition of the p38 MAPK significantly enhanced IFN- γ -induced IL-23p19 mRNA expression (Fig 3.1.8A, middle panel), SB203580 significantly decreased the levels of both IL-12/23p40 and IL-23 protein production (Fig 3.1.8B, 3.1.8C middle panels). In contrast, inhibition of ERK MAPK in monocytes stimulated with IFN- γ did not affect IL-23p19 mRNA or IL-12p40 and IL-23 protein levels (Fig 3.1.8A, B, C right panels). Since JNK MAPK inhibitor, SP600125, enhanced IFN- γ -

Fig 3.1.7 IFN- γ activates ERK, JNK and p38 MAPKs. Positively selected monocytes (1×10^6 /ml) were treated with increasing concentrations of inhibitors specific ERK (PD98059), JNK (SP600125) and p38 (SB202190) MAPK for 2 h followed by IFN- γ (10 ng/ml) stimulation for 15 min. Cell pellets were analyzed by Western immunoblotting for phosphorylation of each MAPK. The results shown are representatives of three independent experiments.

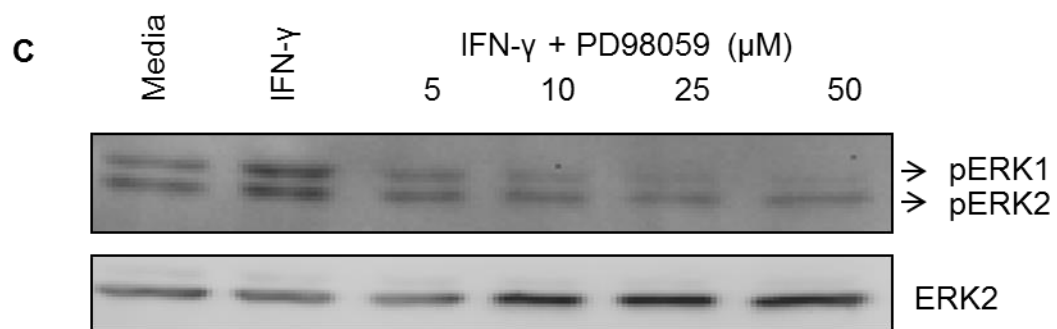
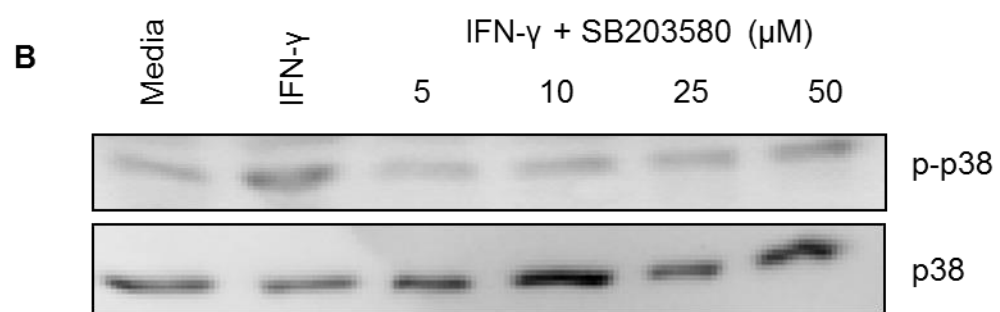
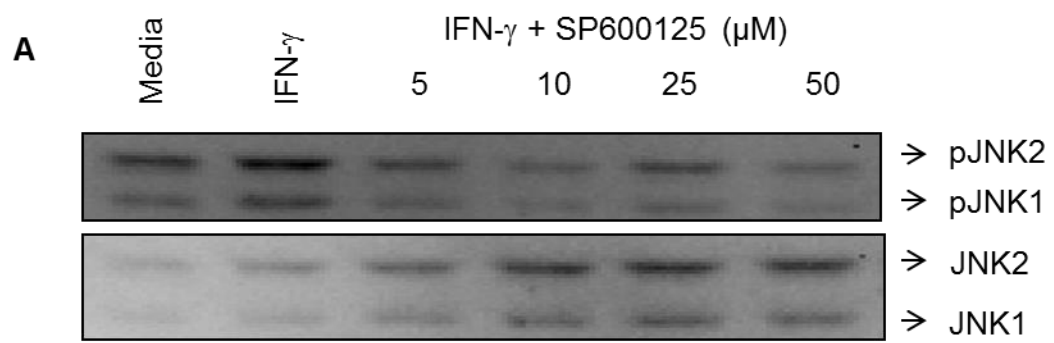

Fig. 3.1.8 IFN- γ -induced IL-12p40 and IL-23 expression is positively regulated by p38 MAPK and negatively regulated by the JNK MAPK pathway. Positively selected monocytes (1×10^6 /ml) were treated with increasing concentrations of ERK (PD98059, right panel), JNK (SP600125, left panel) or p38 (SB202190, middle panel) MAPK inhibitors for 2 h followed by stimulation with IFN- γ (10 ng/ml, 16 h) for quantification of IL-23p19 mRNA expression by RQ-PCR (n=3) (A) or IL-23 (n=5) (B) and IL-12/23p40 (n=5) (C) protein production by ELISA. The results are shown as mean \pm SEM of 3-5 independent experiments, * $p < 0.05$; Unstim- unstimulated.

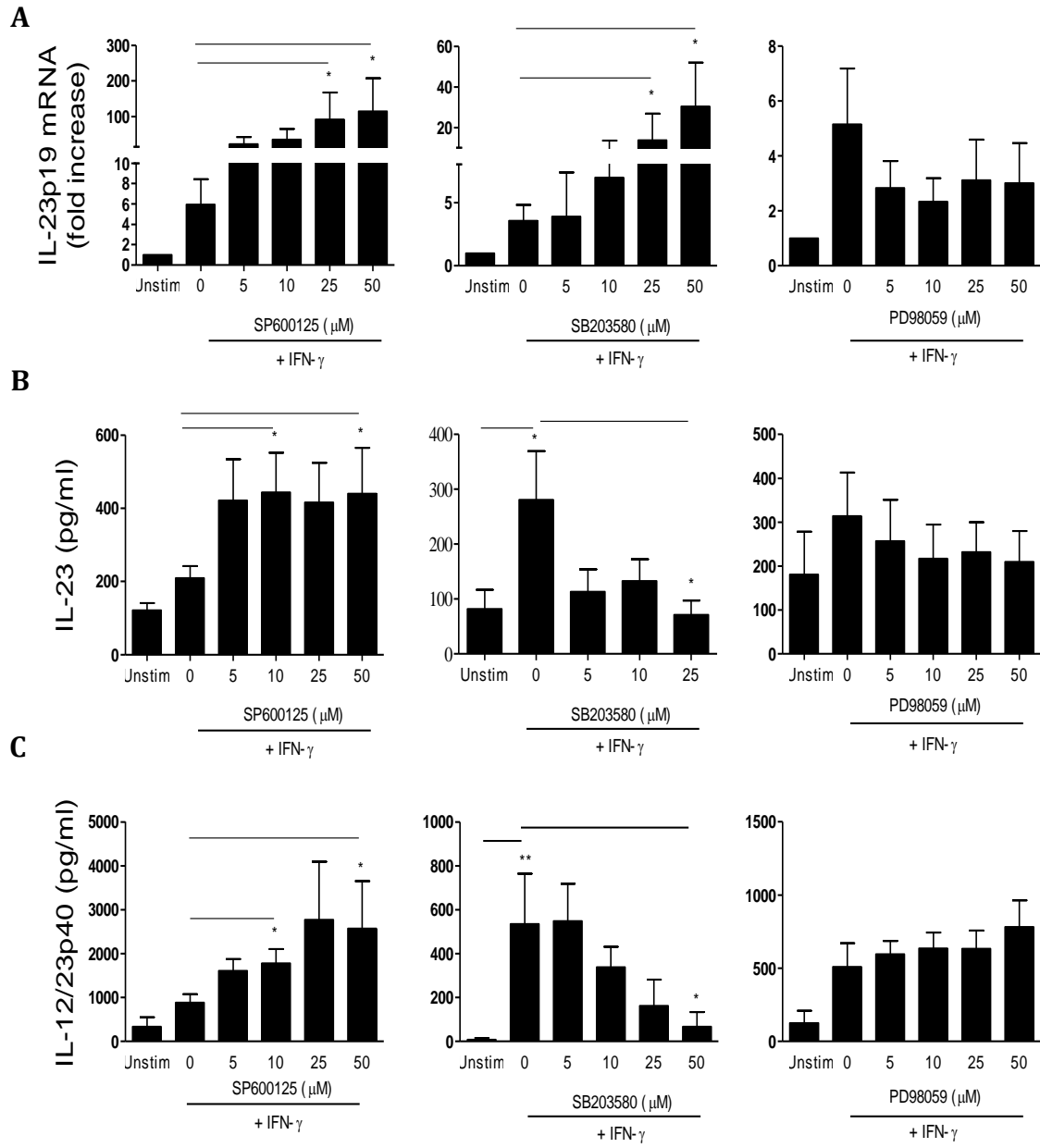

Figure 3.1.8

induced IL-23 production, therefore I demonstrated that SP600125 alone did not induce IL-23 production non-specifically beyond the basal levels (Fig 3.1.9).

Role of calcium signalling in IFN- γ -induced IL-23 expression

LPS-induced IL-12/23p40 expression is regulated in human monocytes by calcium signalling pathway (189). Therefore, the effect of calcium signalling on IFN- γ -induced IL-23 expression was determined in the presence of EGTA, an inhibitor of calcium signalling. Monocytes were treated with EGTA followed by stimulation with IFN- γ and IL-12/23p40 and IL-23 production were determined by ELISA. Monocytic cells pre-treated with EGTA and stimulated with IFN- γ did not show any significant changes in the levels of IL-23 or IL-12/23p40 produced (Fig 3.1.10 A and B, respectively).

In conclusion, my results show that IFN- γ induced the production of IL-12/23p40 and IL-23p19 mRNA, as well as IL-12/23p40 and IL-23 proteins in primary human monocytes isolated by positive selection through anti-CD14 microbeads. In addition, I observed a differential regulation of IL-23p19mRNA and IL-23 protein following IFN- γ stimulation. IFN- γ -induced IL-23 and IL-12/23p40 expression was positively regulated by the p38 MAPK. In contrast, IL-12/23p40 and IL-23 were negatively regulated by the Jak/STAT, PI3K and JNK MAPK in IFN- γ -stimulated monocytes.

Fig. 3.1.9 SP600125, a JNK MAPK inhibitor, does not induce IL-23 production.

Positively selected monocytes (1×10^6 /ml) were treated with increasing concentrations of SP600125. As a control, these cells were stimulated with IFN- γ (10 ng/ml) for 16 h followed by IL-23 quantification by ELISA, n=3. The results are shown as mean \pm SEM of 6 independent experiments, * $p < 0.05$; Unstim- unstimulated.

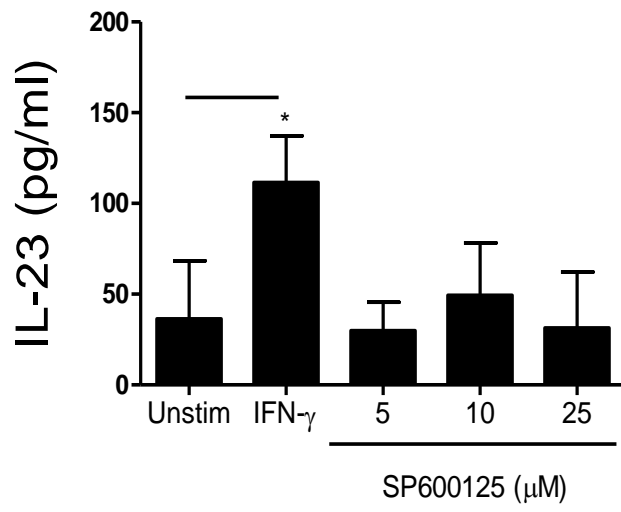

Figure 3.1.9

Fig. 3.1.10 IFN- γ -induced IL-12p40 and IL-23 expression is not regulated by the calcium signaling pathway Positively selected monocytes (1×10^6 /ml) were treated with increasing concentrations of EGTA for 2 h followed by stimulation with IFN- γ (10 ng/ml, 16 h) for quantification of IL-23 (n=5) (A) and IL-12/23p40 (n=4) (B) protein production by ELISA. The results are shown as mean \pm SEM, Unstim- unstimulated.

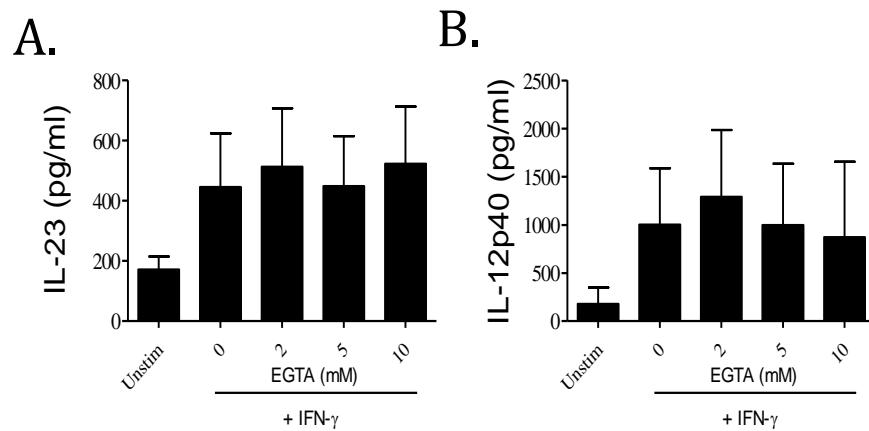

Figure 3.1.10

3.1.2 LPS-induced IL-23 production and its regulation in THP-1 promonocytic cells

LPS has been shown to promote IL-12 production via induction of the MAPKs, PI3K and calcium signalling pathways (10, 121, 190). Recently, IL-23 production has also been reported to be induced following LPS stimulation in human monocytes and PBMCs (110, 191). However, studies examining the signalling pathways involved in LPS-induced IL-23 production have yielded conflicting results. For example, the MAPK and PI3K signalling pathways have both been implicated in the expression of IL-23p19 and IL-12/23p40 mRNA and IL-23 protein secretion in monocytic cells, DCs and the human pro-monocytic THP-1 cell line (10, 109, 111, 140, 192, 193). Studies have shown that LPS-induced IL-23 production is negatively regulated by JNK and p38 MAPKs in monocytic cells (110, 112). My results however, have demonstrated that p38 MAPK is a positive regulator of IL-23 production, while JNK MAPK and PI3K are both negative regulators of IFN- γ -induced IL-23 production in CD14-primed human monocytes (Chapter 3.1, results section).

To further clarify the mechanisms involved in the production IL-23, I employed THP-1 human promonocytic cells as a model system, since these cells are more amenable to approaches, such as siRNA transfections (194). A number of reports suggest that IFN- γ priming may be required to stimulate IL-23 and IL-12 production in a number of different cell types (108, 111, 117, 195, 196). Therefore, I investigated the regulation of IL-23 production in THP-1 cells following stimulation with either IFN- γ or LPS alone, or following LPS stimulation of IFN- γ -primed cells. My results show that LPS induces IL-23p19 mRNA expression as well as IL-12/23p40 and IL-23 protein production. Moreover, LPS-induced IL-23 expression is regulated by the JNK and p38 MAPKs as well as the PI3K signalling pathways.

IFN- γ /LPS induces the expression of IL-12/23p40 and IL-23 production in THP-1 cells

THP-1 cells were stimulated with either LPS or IFN- γ alone or primed with IFN- γ for 16 hr, and afterwards, stimulated with LPS. Cells stimulated with LPS alone displayed increased IL-12/23p40 and IL-23p19 mRNA levels as well as IL-23 and IL-12/23p40 protein production relative to unstimulated cells (Figure 3.2.1A-C). Stimulation with IFN- γ alone did not significantly affect IL-23p19 or IL-12/23p40 mRNA expression or IL-12p40 or IL-23 protein production relative to the unstimulated cells (Figure 3.2.1A-C). Priming of cells with IFN- γ before LPS stimulation resulted in enhanced IL-12/23p40 mRNA expression but had no effect on LPS-induced IL-23p19 mRNA or IL-12/23p40 protein levels compared to LPS-stimulated cells alone (Figure 3.2.1 A-C). Since LPS stimulation alone significantly induced IL-23 and IL-12p40 production, I focused on the signaling pathways involved in IL-23 and IL-12p40 production only in subsequent studies. Surprisingly, priming of cells with IFN- γ before LPS stimulation resulted in decreased IL-23 protein production compared to the cells stimulated with LPS alone (Figure 3.2.1 A-C). However, it should be noted that IFN- γ priming of THP-1 cells had no effect on LPS-induced IL-12/23p40 production.

LPS-induced IL-23 production is regulated by p38 and JNK MAPKs

The roles of MAPKs in the regulation of IL-23p19, IL-12/23p40 and IL-23 expression in LPS-stimulated THP-1 cells were determined by employing inhibitors specific for ERK (PD98059), JNK (SP600125) and p38 (SB203580) MAPKs (10, 110, 111). THP-1

cells were treated with various concentrations of PD98059, SP600125 or SB203580 for 2hr prior to LPS stimulation for 30 min. ERK, JNK and p38 MAPK were phosphorylated in

Fig. 3.2.1 LPS induces IL-23p19 mRNA expression, IL-23 and IL-12/23p40 protein production. (A) THP-1 cells (1×10^6 /ml) were treated with either IFN- γ (10 ng/ml) for 16 hours, LPS (1 μ g/ml) for 4 hours or with both IFN- γ and LPS for 16 hours and 4 hours, respectively. IL-23p19 and IL-12/23p40 mRNA expression were quantified by relative quantitative real-time PCR. (B) THP-1 cells (1×10^6 /ml) were treated with either IFN- γ (10 ng/ml) for 16 hours, LPS (1 μ g/ml) for 24 hours or with both IFN- γ and LPS for 16 hours and 24 hours, respectively. IL-23 protein production was then determined from the cell culture supernatants by ELISA. (C) THP-1 cells (1×10^6 /ml) were treated with either IFN- γ (10 ng/ml) for 16 hours, LPS (1 μ g/ml) for 24 hours or with both IFN- γ and LPS for 16 hours and 24 hours, respectively. IL-12p40 protein production was then determined by ELISA. The results are shown as mean \pm SEM of 3-5 independent experiments, Unstim- unstimulated. Results were generated by Dr. Ali R. Rahimi

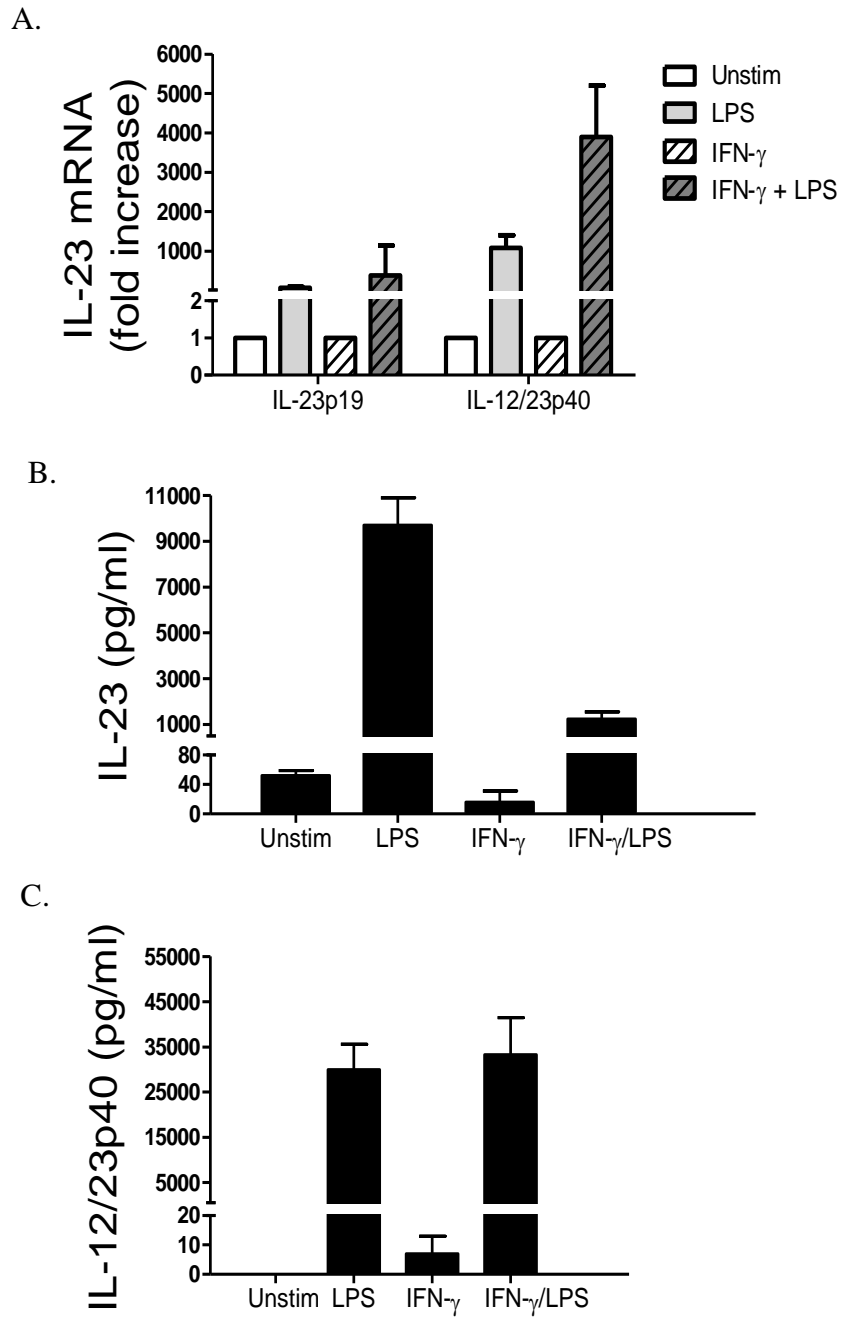

Figure 3.2.1

THP-1 cells following stimulation with LPS (Fig 3.2.2). Cells pretreated with SB203580, PD98059 or SP600125 showed a significant dose-dependent decrease in phosphorylation of p38, ERK and JNK, respectively, following LPS stimulation (Fig 3.2.2). These results show the ability of each inhibitor to block their specific signaling pathways.

Inhibition of ERK, JNK or p38 MAPK caused an increase in IL-23p19 mRNA levels (Figure 3.2.3 A-C left panels). However, inhibition of JNK and p38 MAPK decreased IL-23 (Figure 3.2.3 B and C, middle panels) and IL-12/23p40 protein production (Figure 3.2.3 B and C right panels) with increasing concentrations of each inhibitor. In contrast, inhibition of the ERK pathway by PD98059 did not significantly affect either IL-23 (Fig 3.2.3A, middle panel) or IL-12p40 protein production (Fig 3.2.3A, right panel). These results suggest that p38 and JNK pathways positively regulate LPS-induced IL-23 and IL-12p40 production but negatively regulate IL-23p19 mRNA expression.

The role of JNK and p38 MAPK in LPS-induced IL-23p19 mRNA and total IL-23 protein expression was further confirmed using siRNA transfection to inhibit these signalling proteins. THP-1 cells were transfected with either p38 or JNK specific or control siRNAs for 24 hr, following which cells were stimulated with LPS for another 24 hr for IL-12/23p40 and IL-23 protein production. The ability of JNK and p38 MAPK siRNA to prevent phosphorylation of their respective proteins in response to LPS stimulation was determined by Western blot analysis. JNK siRNA significantly reduced pJNK and total JNK in unstimulated as well as LPS-stimulated cells compared to the cells transfected with control siRNAs (Fig 3.2.4 A). Similarly, JNK siRNA significantly reduced LPS-induced IL-12/23p40 and IL-23 protein production relative to the cells transfected with control siRNAs

Fig. 3.2.2 Inhibition of LPS-induced ERK, JNK and p38 phosphorylation in THP-1 cells. THP-1 cells (1×10^6 /ml) were treated with increasing concentrations of (A) ERK (PD98059), (B) JNK (SP600125) or (C) p38 (SB203580) MAPK inhibitors for 2 hours followed by stimulation with LPS ($1 \mu\text{g}/\text{ml}$) for 30 minutes. Cell culture supernatants were collected and phosphorylation of each MAPK was determined by Western blot. Total proteins ($30 \mu\text{g}$) were analyzed by Western blot analysis using anti-phospho-ERK (p-ERK), anti-phospho-JNK (p-JNK), or anti-phospho-p38 (p-p38) antibodies. The membranes were stripped and re-probed with anti-ERK, anti-JNK, or anti-p38 antibodies, respectively, to control for protein loading. The results shown are representatives of three independent experiments. Results were generated by Dr. Ali R. Rahimi.

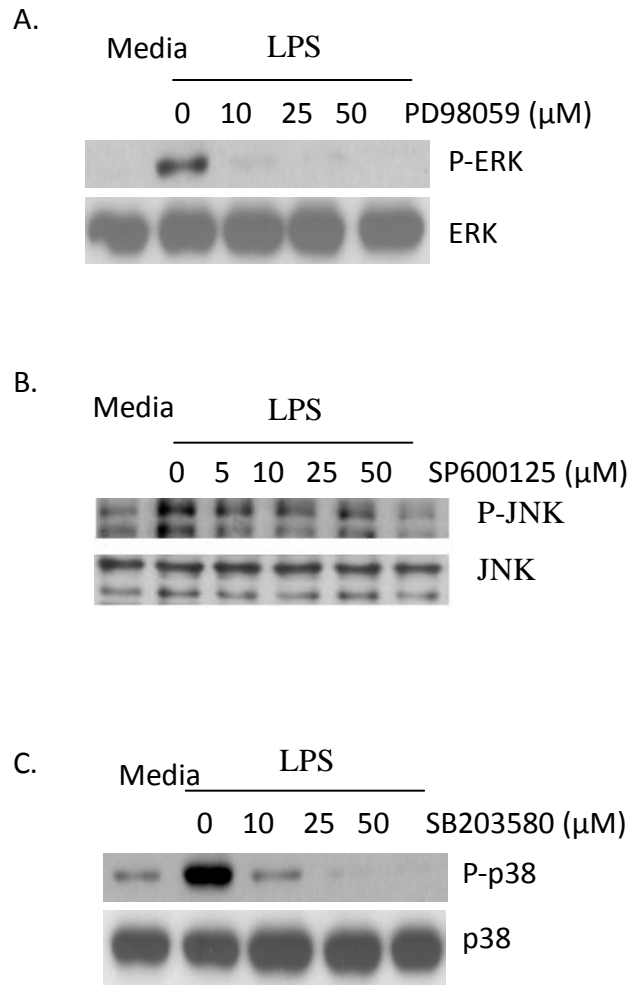

Figure 3.2.2

Fig. 3.2.3 LPS-induced IL-23 production is positively regulated through JNK and p38 MAPK signaling pathways. THP-1 cells (1×10^6 /ml) were treated with increasing concentrations of ERK (PD98059) (n=3), JNK (SP600125) (n=4) or p38 (SB202190) (n=5) MAPK inhibitors for 2 h followed by LPS ($1 \mu\text{g}/\text{ml}$) for 4 h. IL-23p19 mRNA expression was then quantified by relative quantitative real-time PCR. THP-1 cells (1×10^6 /ml) were also treated with increasing concentrations of ERK (PD98059), JNK (SP600125) or p38 (SB203580) MAPK inhibitors for 2 hours followed by LPS ($1 \mu\text{g}/\text{ml}$) for 24 hours. IL-23 and IL-12/23p40 protein production were quantified from the culture supernatants by ELISA. The results are shown as mean \pm SEM, * $p < 0.05$; ** $p < 0.01$; *** $p < 0.001$, Unstim-unstimulated. Results were generated in collaboration with Dr. Ali R. Rahimi.

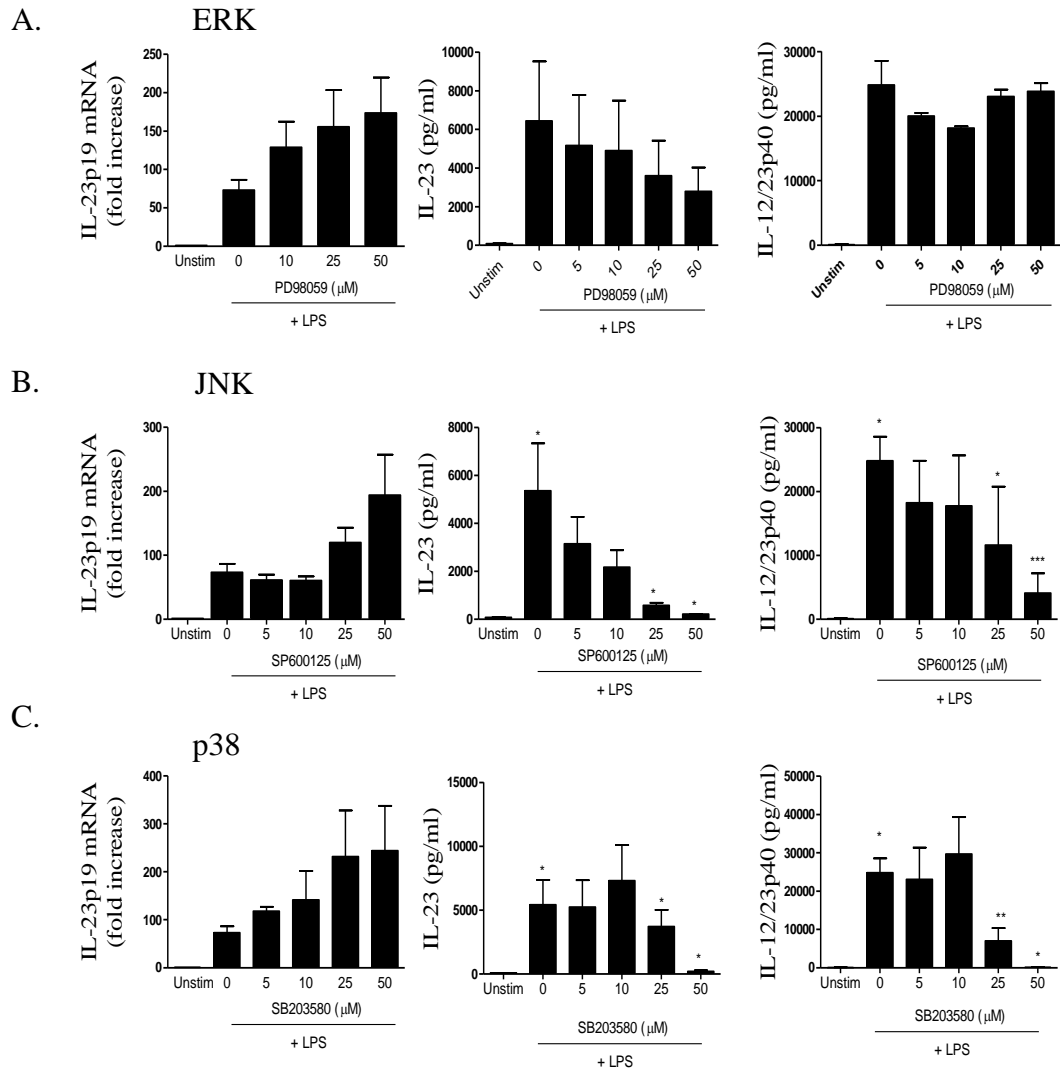

Figure 3.2.3

Fig. 3.2.4 JNK MAPK siRNA down-regulates LPS-induced IL-23 expression. (A) THP-1 cells (2.5×10^5) were transfected with either control siRNA or JNK MAPK siRNA for 24 hours followed by stimulation with LPS ($1 \mu\text{g/ml}$) for 30 minutes for the determination of phosphorylated JNK MAPK by Western blot analysis. The result is a representative of 3 independent experiments. Cells were transfected with either control siRNA or JNK MAPK siRNA for 24 h followed by stimulation with LPS ($1 \mu\text{g/ml}$) for 24 hours for assessment of IL-12/23p40 (n=7) (B) and IL-23 (n=5) (C) protein production by ELISA. The results are shown as mean \pm SEM of 3 to 5 independent experiments; ** p < 0.01; *** p < 0.001, ctrl – control siRNA.

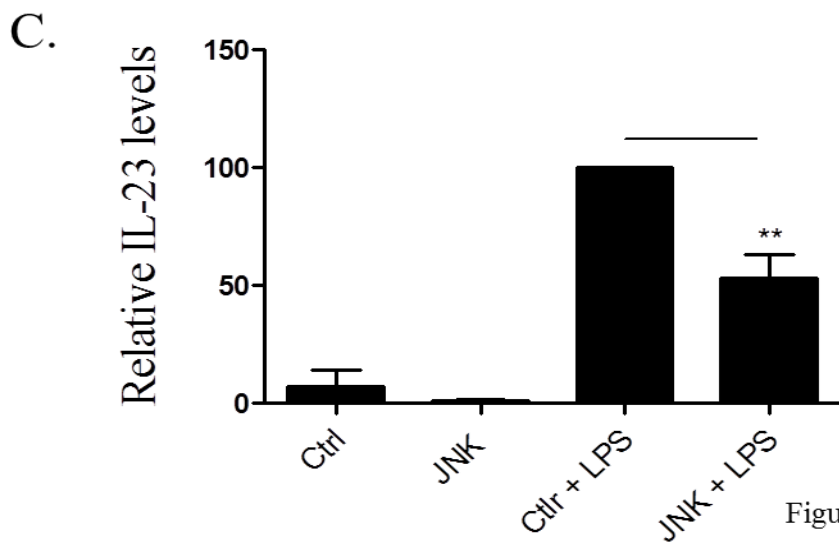
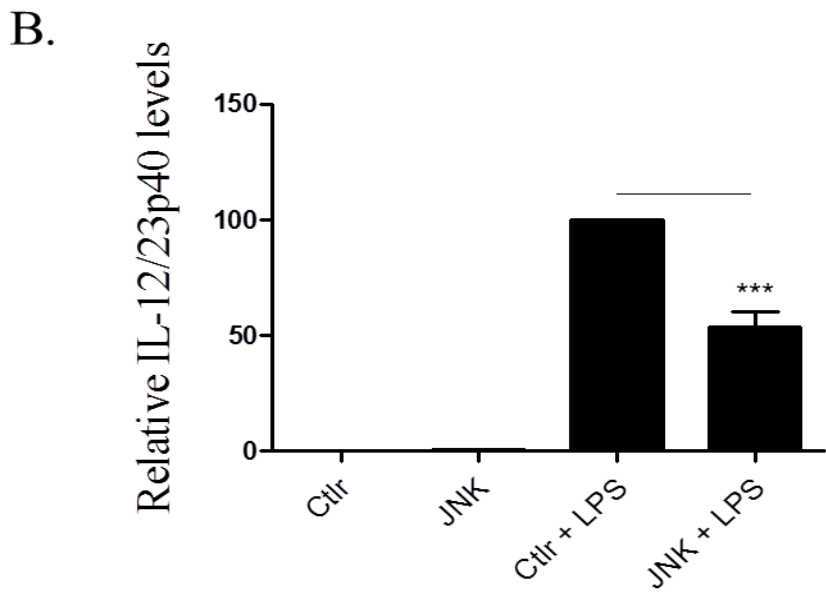
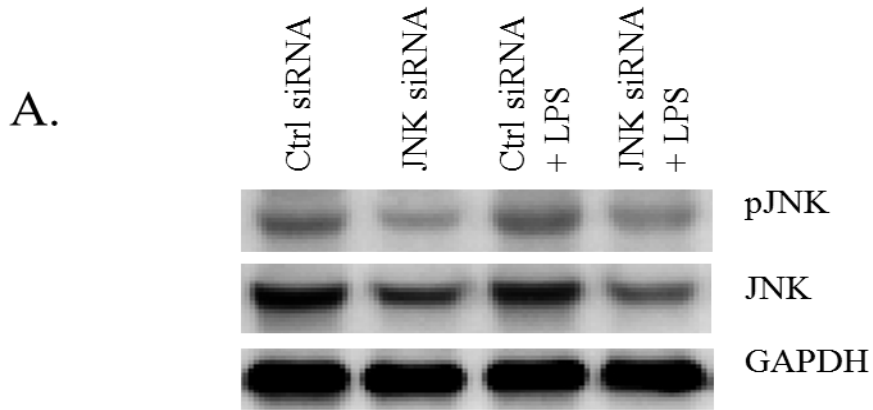

Figure 3.2.4

(Fig 3.2.4 B and C). p38 MAPK siRNA significantly reduced phospho-p38 and total p38 MAPKs in unstimulated as well as LPS-stimulated cells compared to the cells transfected with control siRNAs (Fig 3.2.5A). Furthermore, p38 siRNA significantly reduced LPS-induced IL-12/23p40 and IL-23 protein production relative to the cells transfected with control siRNAs (Fig 3.2.5 B and C) and to the expression of p42/44 ERK MAPK.

Role of the PI3K signalling in LPS-induced IL-23 expression.

IL-23 expression has previously been reported to be regulated by the PI3K signalling pathway (86, 140). Therefore, the effect of PI3K on LPS-induced IL-23 expression was evaluated. The ability of the PI3K inhibitor, LY294002, to prevent Akt phosphorylation in LPS-treated THP-1 cells was first determined by Western blot analysis. THP-1 cells were treated with various concentrations (0-50 μ M) of LY294002 for 2hr prior to LPS stimulation for 15 min. As expected, Akt phosphorylation was decreased in these cells with increasing concentrations of inhibitor relative to cells stimulated with LPS alone (Fig 3.2.6A), indicating that the inhibitor was functioning under these experimental conditions. The effect of PI3K inhibition on IL-23 expression was then determined. THP-1 cells pre-treated with increasing concentrations of PI3K inhibitor for 2 h were stimulated with LPS for either 4 h for mRNA expression or for 24h for IL-12/23 and IL-23 protein expression as determined by real-time PCR and ELISA, respectively. The results show that inhibition of PI3K pathway in LPS-stimulated cells did not affect IL-23p19 mRNA levels compared to the LPS-stimulated cells (Figure 3.2.6B left panel). However, inhibition of PI3K pathway significantly decreased both LPS-induced IL-12/23p40 and IL-23 protein production compared to the untreated control cells (Figures 3.2.6 C).

Fig. 3.2.5 p38 MAPK siRNA down-regulates LPS-induced IL-23 expression. (A) THP-1 cells (2.5×10^5) were transfected with the either control siRNA or p38 MAPK siRNA for 24 hours followed by stimulation with LPS ($1 \mu\text{g/ml}$) for 30 minutes for the determination of phosphorylated p38 MAPK by Western blot analysis. The result is a representative of 3 independent experiments. THP-1 cells were transfected with the either control siRNA or p38 MAPK siRNA for 24 h followed by stimulation with LPS ($1 \mu\text{g/ml}$) for 24 hours for assessment of IL-12/23p40 (n=10) (B) or IL-23 protein production (n=5) (C) by ELISA. The results are shown as mean \pm SEM of 3 to 5 independent experiments; ** $p < 0.01$; *** $p < 0.001$, ctrl – control siRNA.

A.

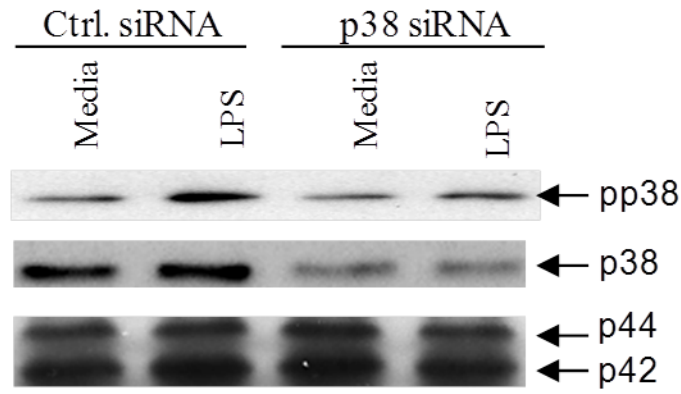

B.

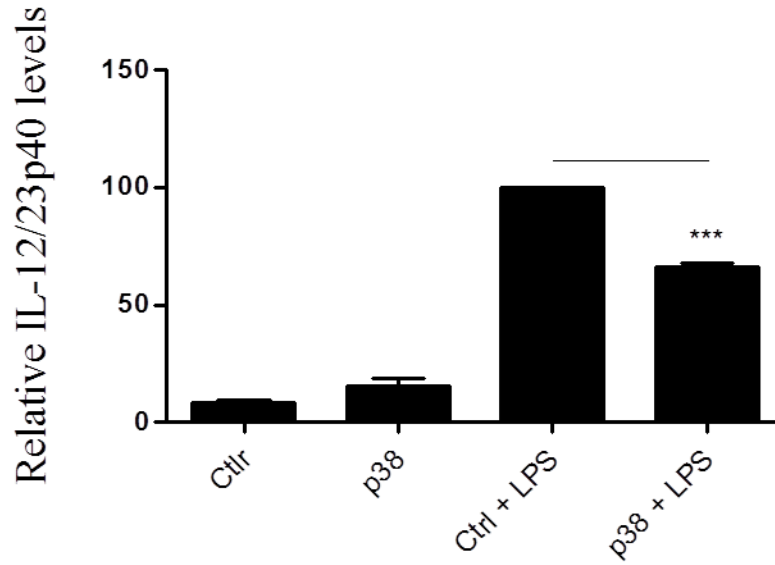

C.

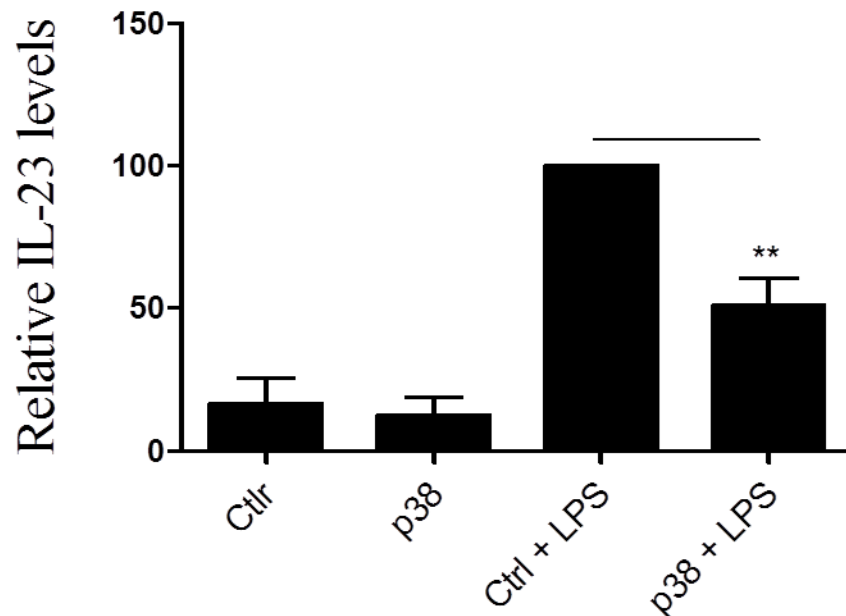

Figure 3.2.102

Fig. 3.2.6 LPS-induced IL-23 production is positively regulated through PI3K signaling pathways in THP-1 cells. (A) THP-1 cells ($1 \times 10^6/\text{ml}$) were treated with increasing concentrations of the PI3K inhibitor LY294002 (0 to 50 μM) for 2 hours followed by LPS (1 $\mu\text{g}/\text{ml}$) for 30 minutes. Cell culture supernatants were collected and PI3K phosphorylation was determined by Western blot analysis. Total proteins (30 μg) were analyzed by Western blot analysis using anti-phospho-Akt (p-Akt) antibodies. Membranes were stripped and re-probed with anti-Akt antibodies to control for protein loading. The results shown are representatives of three independent experiments. (B) THP-1 cells ($1 \times 10^6/\text{ml}$) were treated with increasing concentrations of the PI3K inhibitor LY294002 (0 to 50 μM) for 2 hours followed by LPS (1 $\mu\text{g}/\text{ml}$) for 4 hours, n=3. IL-23p19 mRNA expression was then quantified by relative quantitative real-time PCR. THP-1 cells ($1 \times 10^6/\text{ml}$) were also treated with increasing concentrations of the PI3K inhibitor LY294002 (0 to 50 μM) for 2 hours followed by LPS (1 $\mu\text{g}/\text{ml}$) for 24 hours. (C) IL-23 (n=5) and IL-12/23p40 (n=3) protein production were quantified from the culture supernatants by ELISA, n=3. The results are shown as mean \pm SEM, * p < 0.05; ** p < 0.01; *** p < 0.001, Unstim- unstimulated.

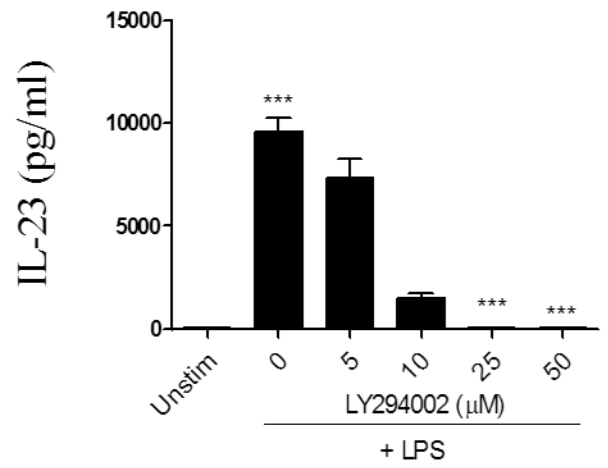
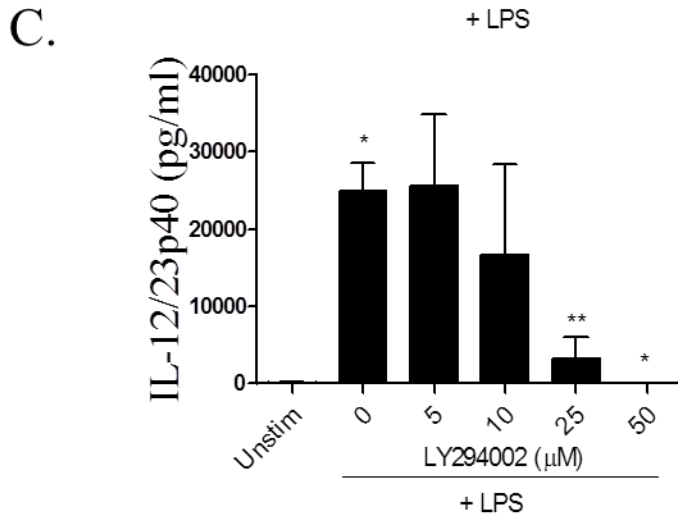
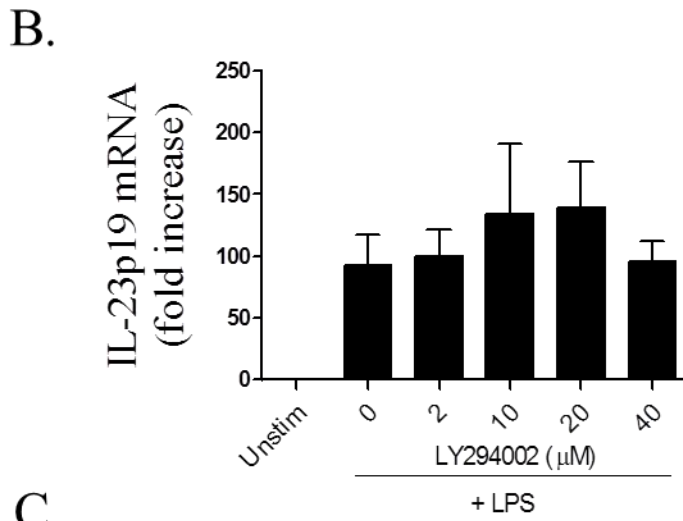
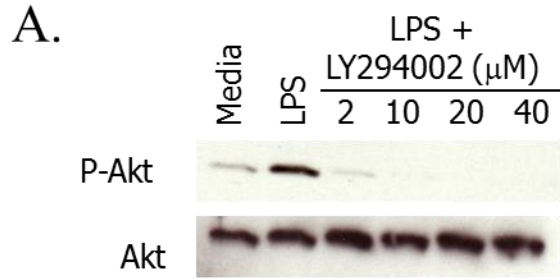

Figure 3.2.6

To confirm the above results obtained with PI3K pharmacological inhibitor, transfection of THP-1 cells with specific siRNA was employed. PI3K is a heterodimeric protein composed of a regulatory p85 subunit that integrates signals from various tyrosine kinase-linked receptors and intracellular proteins. Upon signaling, the catalytic p110 subunit binds to p85, forming an active enzyme. THP-1 cells were transfected with siRNA specific for PI3Kp85 α or nonspecific control pool. Following transfection, cells were cultured for an additional 16 hr and then stimulated with LPS for 24 h for protein analysis by ELISA. Cells treated with p85 siRNA decreased the level of p85 phosphorylation in unstimulated as well as LPS stimulated cells compared to the cells transfected with control siRNA (Fig 3.2.7A). Cells treated with PI3K siRNA showed a decrease in LPS-induced IL-12p40 and IL-23 protein production relative to cells treated with control siRNA (Fig 3.2.7B and C).

Taken together, these results show that LPS significantly stimulated IL-23p19 and IL-12/23p40 mRNA expression as well as IL-12/23p40 and IL-23 protein production in promonocytic THP-1 cells. LPS-induced IL-23 production in THP-1 cells is positively regulated through the JNK, p38 MAPKs and PI3K pathways. In contrast, IFN- γ stimulation alone did not affect either IL-23 mRNA or protein levels.

Fig. 3.2.7 PI3K siRNA down-regulates LPS-induced IL-23 expression. (A) THP-1 cells (2.5×10^5) were transfected with the either control siRNA or p85 PI3K siRNA for 24 hours followed by stimulation with LPS ($1 \mu\text{g/ml}$) for 30 minutes for the determination of phosphorylated p85 PI3K by Western blot analysis. The result is a representative of 3 independent experiments. THP-1 cells were transfected with the either control siRNA or p85 PI3K siRNA for 24 h followed by stimulation with LPS ($1 \mu\text{g/ml}$) for 24 hours for assessment of IL-12/23p40 (n=4) (B) or IL-23 (n=6) (C) protein production by ELISA. The results are shown as mean \pm SEM, ctrl – control.

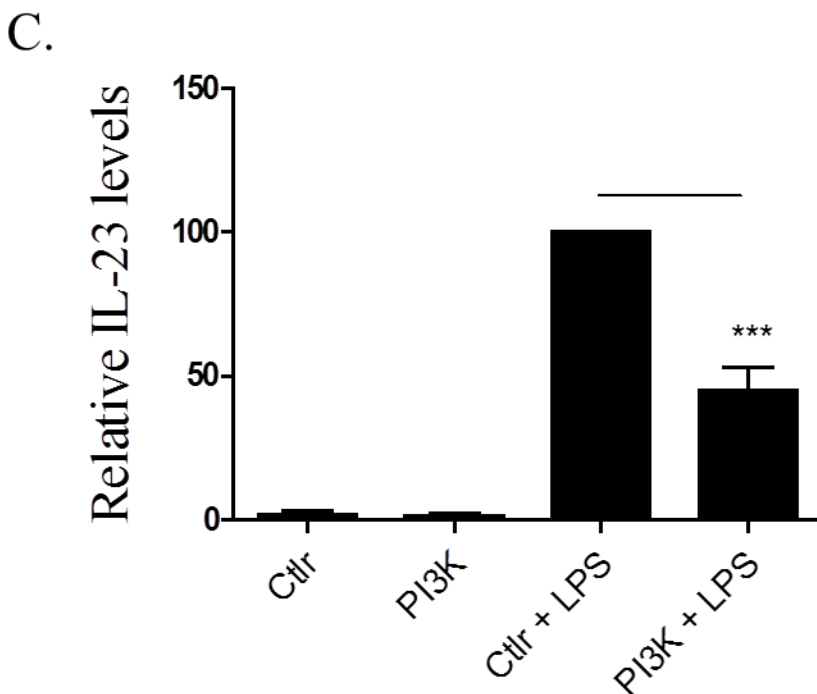
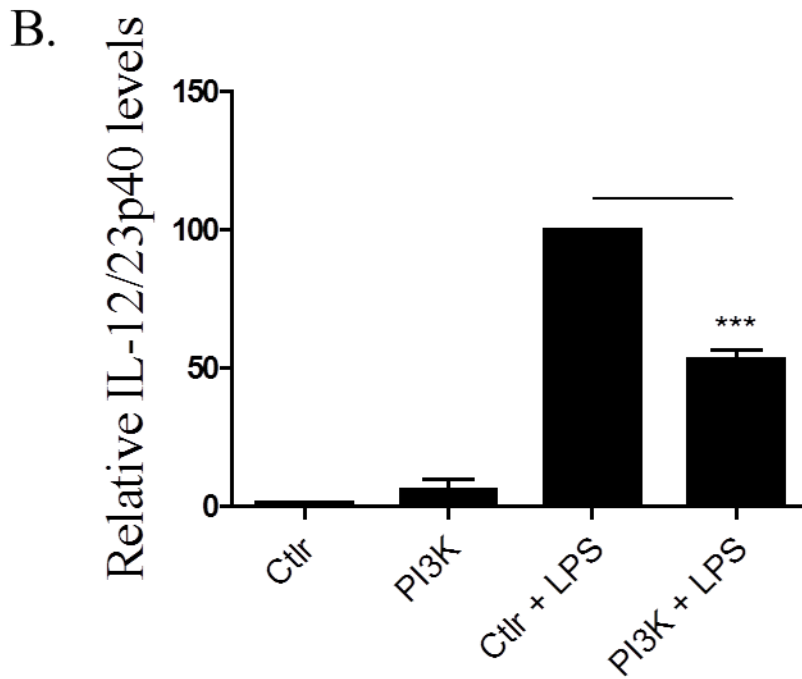
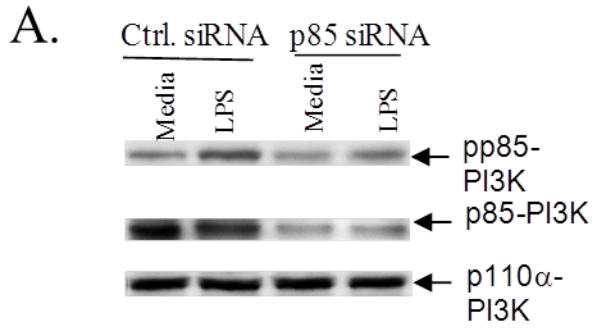

Figure 3.2.7

3.3 INF- γ /LPS-induced IL-23 production and its regulation in human monocyte-derived macrophages

Previous studies demonstrated that the regulation of IL-23 production and expression of its subunits is differentially regulated in myeloid cell subtypes, such as monocytes and DCs (51)(86, 145)(109, 141), my work from chapters 3.1 and 3.2). It was therefore of interest to investigate the production of IL-23 in response to LPS and/or IFN- γ in monocyte-derived macrophages.

Generation and characterization of MDMs

Human monocytic cells were differentiated using M-CSF into MDMs, as described in the Materials and Methods section. Following 6 days in culture, MDMs were assessed for surface expression of CD11a, CD11b, CD11c, CD80, CD83, CD86, CD16 and HLA-DR by flow cytometry (Figure 3.3.1). CD11a, CD11b, CD11c are leukocyte adhesion surface receptors and were highly expressed on MDMs. Furthermore, the co-stimulatory molecule CD80 were also highly expressed on MDMs, in contrast with CD83, a dendritic cell maturation marker. HLA-DR, a MHC II class receptor is expressed on the cell surface of MDMs, coinciding with the antigen-presenting cell phenotype. Six-day old MDMs highly expressed macrophage markers including, CD11a, CD11b, CD11c, HLA-DR and CD16 (Figure 3.3.1).

IFN- γ /LPS and LPS alone induce IL-12p40 and IL-23 production in human MDMs

Next, I wanted to investigate whether IL-12p40 and IL-23 are produced by MDMs following stimulation with either IFN- γ or LPS alone or following LPS stimulation of IFN- γ -primed cells. For this, MDMs were stimulated with either IFN- γ alone (10 ng/ml), LPS alone (1 μ g/ml) or with IFN- γ (10 ng/ml) for 16 hr followed by LPS (1 μ g/ml) for 4 hr for quantification and the expression of mRNA was assessed by relative quantitative real-time PCR. Cells were also stimulated with IFN- γ (10 ng/ml) alone for 16hr, LPS for 24 hr or with IFN- γ for 16 hr followed by LPS stimulation (1 μ g/ml) for 24hr for quantification of protein secretion in the culture supernatants by ELISA. IFN- γ stimulation alone did not induce the expression of either IL-23p19, or IL-12/23p40 mRNA, or the production of IL-12/23p40 or IL-23 proteins (Figure 3.3.2). In contrast, LPS stimulation of MDMs resulted in the expression of IL-23p19 and IL-12/23p40 mRNA as well as the production of IL-12/23p40 and IL-23 proteins (Figure 3.3.2). Interestingly, pre-treatment of MDMs with IFN- γ prior to their stimulation with LPS further enhanced by several fold IL-12/23p40, IL-23p19 mRNA expression and as well as IL-12/23p40 and IL-23 protein secretion (Figure 3.3.2). This synergistic effect of IFN- γ and LPS-induced production of both IL-12/23p40 and IL-23 was of interest, and prompted me to investigate the signalling pathways involved.

IL-12p40 and IL-23 expression in LPS- and IFN- γ /LPS-stimulated macrophages is not regulated by the MAPK pathway

My previous results, demonstrated that the regulation of IL-12/23p40 and IL-23 expression in LPS and IFN- γ -stimulated THP-1 cells involved activation of JNK, p38 MAPKs and PI3K. Therefore, it was of interest to examine if these pathways were also involved in the expression of IL-12/23p40 and IL-23 in MDMs by LPS alone as well as

Fig 3.3.1 Monocyte-derived macrophage characterization. PBMCs (5×10^6 cells) were plated and monocytes were differentiated into macrophages with M-CSF over 6 days. Cells were washed and stained with PE-conjugated antibodies for 15 minutes. Surface expression of CD83, CD80, CD16, CD11a, CD11b, CD11c and HLA-DR was assessed by flow cytometry. The result is a representative of 3 independent experiments. Results were generated by Dr. Aurelia Busca.

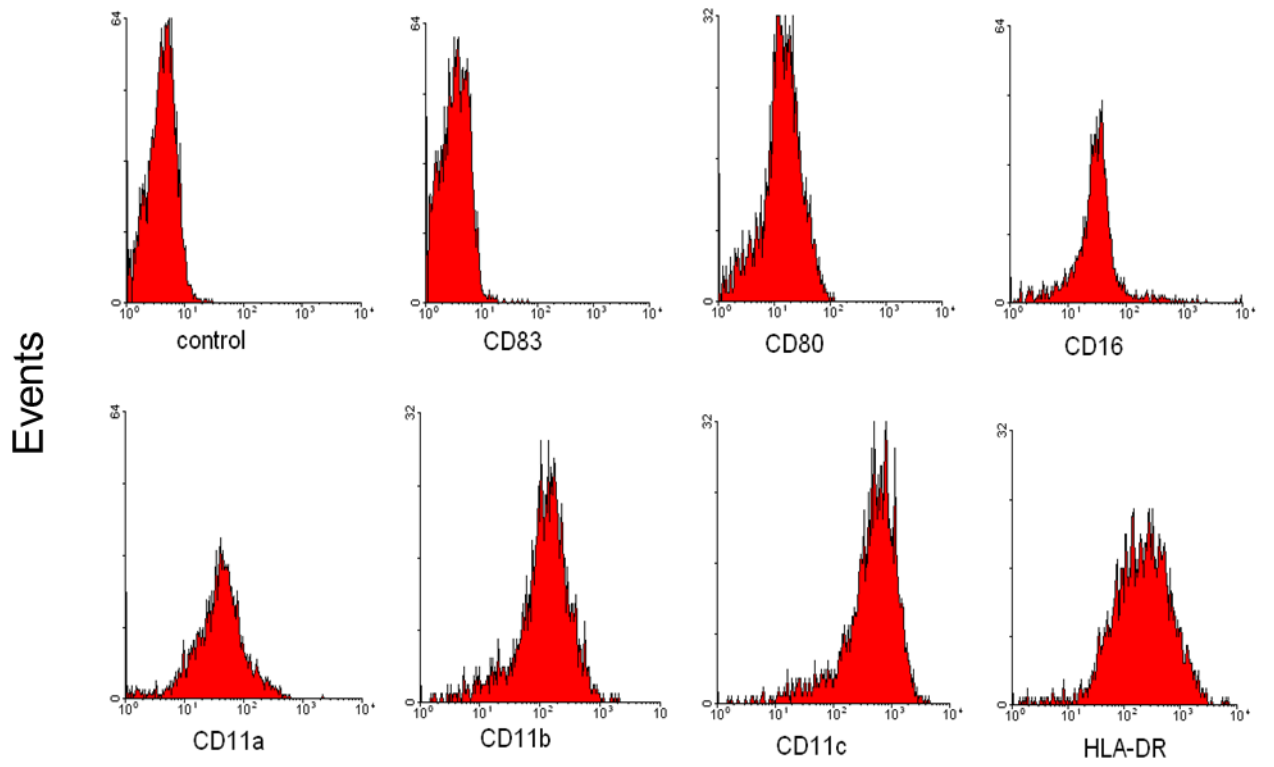

Figure 3.3.1

Fig. 3.3.2 LPS and IFN- γ /LPS induce IL-23 expression in monocyte-derived macrophages. MDMs were treated with IFN- γ (10 ng/ml, 16 h) followed by LPS (1 μ g/ml, 4 h). IL-12p40 and IL-23p19 mRNA expression were quantified by relative quantitative real-time PCR (upper and middle panels). Cells (1×10^6 /ml) were treated with IFN- γ (10 ng/ml, 16 h) followed by LPS (1 μ g/ml, 24 h) and IL-12p40 and IL-23 protein production was determined by ELISA. The results are shown as mean \pm SEM (n=7), * p < 0.05; ** p < 0.01, Unstim- unstimulated.

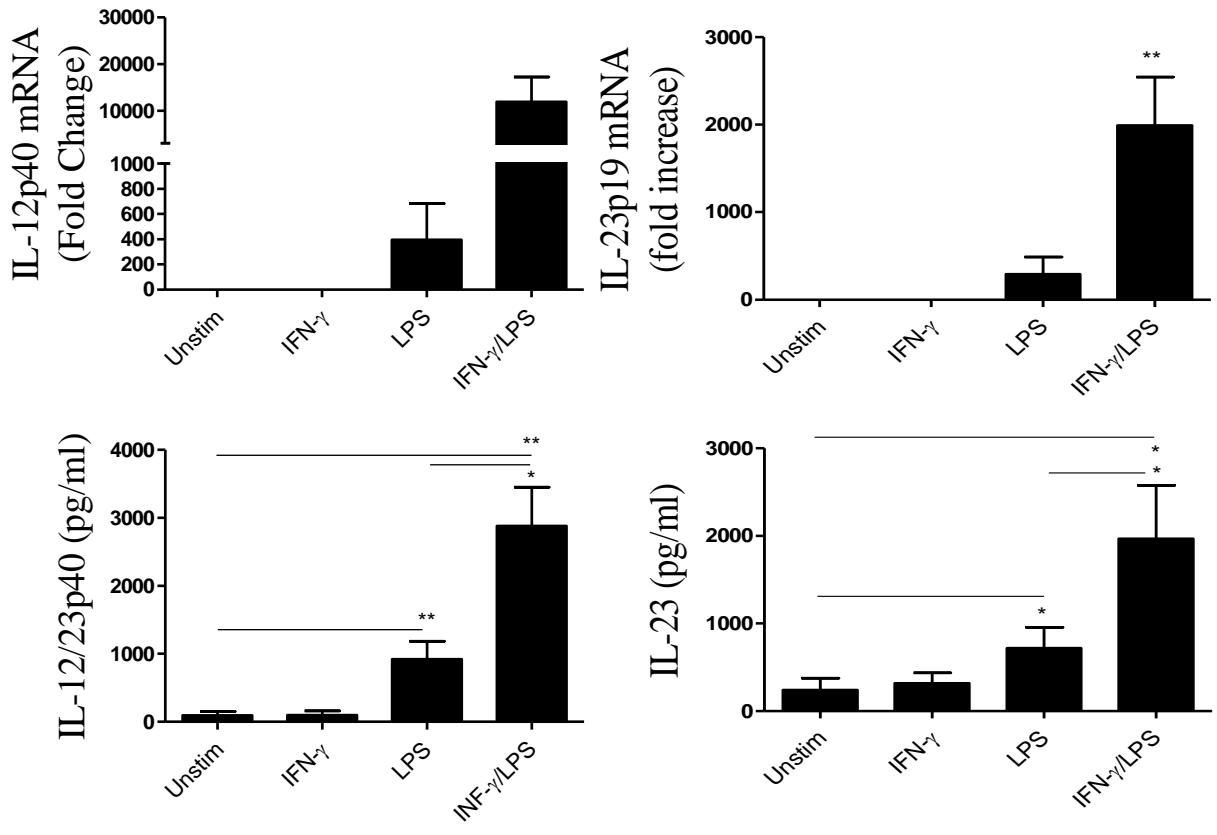

Figure 3.3.2

following IFN- γ priming and LPS-stimulation. MDMs were treated for 2hr with increasing concentrations of MAPK inhibitors namely PD98059, SP600125 or SB203580. Subsequently, cells were first stimulated LPS alone for 24hr and IL-12/23p40 and IL-23 production was examined by ELISA (Figures 3.3.4, 3.3.6 and 3.3.8). The results show that although LPS was able to induce both IL-12/23p40 and IL-23 production, none of the MAPK inhibitors abrogated the expression of these two proteins in MDMs. Next, I have examined whether these MAPK inhibitors regulated the production of IL-12/23p40 and IL-23 in MDMs stimulated with IFN- γ and LPS. For this, the cells were treated for 2hr with MAPK inhibitors, following by priming with IFN- γ for 16hr and finally treating with LPS for 4hr for mRNA analysis and 24hr for ELISA (Figures 3.3.4, 3.3.6 and 3.3.8). The results show that although IFN- γ /LPS stimulation was able to enhance IL-12/23p40 and IL-23 production, MAPKs were not involved in this regulation (Figures 3.3.3, 3.3.5 and 3.3.7). As a control, LPS induced JNK, p38 and ERK MAPK phosphorylation in MDMs and this was prevented using their respective signaling inhibitors for ERK (PD98059), JNK (SP600125) and p38 (SB203580) MAPKs (data not shown).

IL-12p40 and IL-23 expression in LPS- and IFN- γ /LPS-stimulated macrophages is not regulated by the PI3K pathway

IL-23 has also been shown to be positively regulated by the PI3K pathway following infection of human monocytic cells with *Francisella tularensis* and *Mycobacterium tuberculosis* (86, 140), as well as in the THP-1 monocytic cell line (Figure 3.2.6). Therefore, I determined the role of PI3K signalling in the regulation of IL-12/23p40 and IL-23 expression in LPS- and IFN- γ /LPS-stimulated MDMs by using a pharmacological PI3K

Fig. 3.3.3 IFN- γ /LPS-induced IL-23 production is not regulated through the JNK MAPK pathway in human MDMs. MDMs were treated with increasing concentrations of JNK MAPK inhibitor, SP600125 (0-50 μ M) for 2 h followed by stimulation with IFN- γ (10 ng/ml, 16 h) and LPS (1 μ g/ml, 4 h) for quantification of IL-12p40 and IL-23-19 mRNA expression by RQ-PCR, whereas IL-12p40 and IL-23 protein production was determined by ELISA, IFN- γ (10 ng/ml, 16 h) and LPS (1 μ g/ml, 24 h). The results are shown as mean \pm SEM (n=7), Unstim- unstimulated.

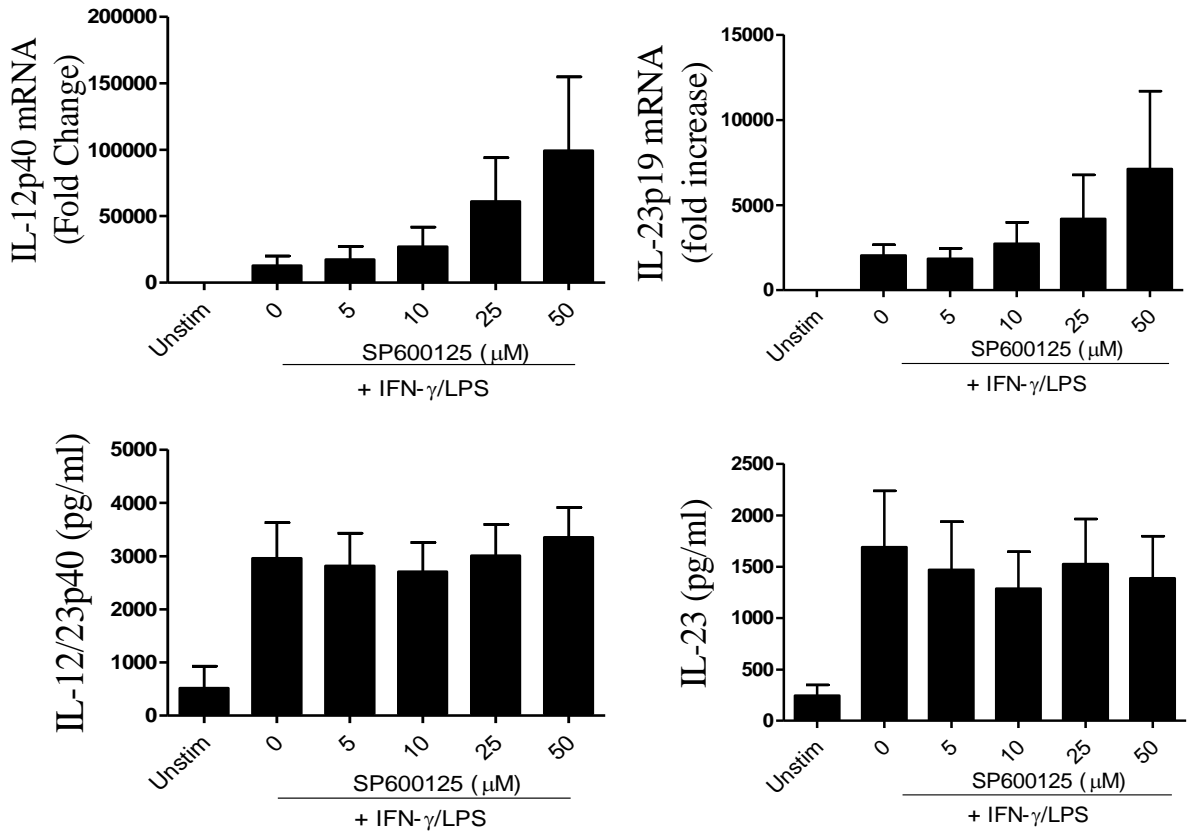

Figure 3.3.3

Fig. 3.3.4 LPS-induced IL-23 production is not regulated through the JNK MAPK pathway in human MDMs. MDMs were treated with increasing concentrations of JNK MAPK inhibitor, SP600125 (0-50 μ M) for 2 h followed by stimulation with LPS (1 μ g/ml, 24 h) for quantification of IL-23 and IL-12p40 protein production, determined by ELISA. The results are shown as mean \pm SEM (n=7), Unstim- unstimulated.

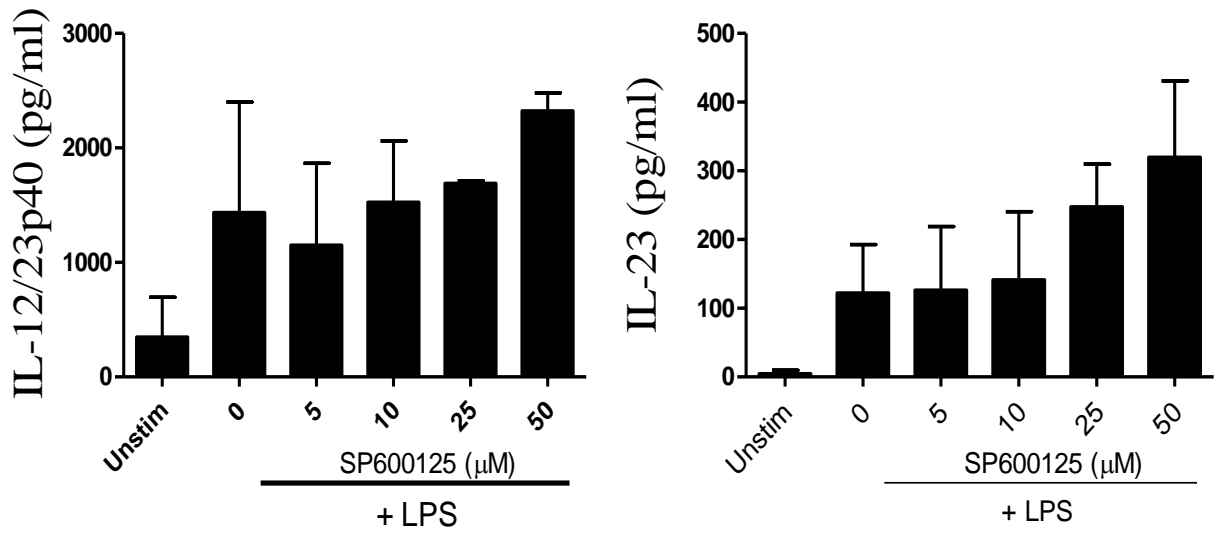

Figure 3.3.4

inhibitor, LY294002. The ability of the PI3K inhibitor, LY294002, to prevent Akt phosphorylation in LPS-treated MDMs was first determined by Western blot analysis. MDMs were treated with various concentrations of LY294002 for 2hr prior to LPS stimulation for 15 min. As expected, LPS induced Akt phosphorylation and this was prevented using LY294002 (data not shown), indicating the biological activity of the inhibitor.

MDMs were treated with LY294002 for 2hr, followed by stimulation with either LPS alone or with IFN- γ for 16 hr and by subsequent LPS-stimulation. Quantification of IFN- γ /LPS-induced IL-12p40 and IL-23 expression was performed using real-time PCR and ELISA. Inhibition of PI3K pathway in IFN- γ /LPS or LPS-stimulated macrophages did not change IL-12/23p40 nor IL-23 protein production (Figure 3.3.9 and 3.3.10). These results suggest that IL-12/23p40 and IL-23 expression is not regulated by the PI3K pathway in LPS- or IFN- γ /LPS-stimulated MDMs (Figure 3.3.9 and 3.3.10, respectively).

IL-12p40 and IL-23 expression in IFN- γ /LPS-stimulated macrophages is not regulated by the Jak/STAT pathway.

Keeping in view that MAPKs and PI3K do not regulate IL-12/23p40 and IL-23 production in IFN- γ /LPS-stimulated MDMs, I next examined the role of the Jak/STAT pathway in the regulation of these cytokines. IFN- γ mediates its effects primarily through the activation of Jak/STAT pathway (103). Therefore, the role of this pathway in regulating IFN- γ /LPS-induced IL-23 expression was investigated using Jak inhibitor-I which inhibits the Jak/STAT pathway. MDMs pre-treated with Jak inhibitor-I were primed with IFN- γ for 16 hr followed by LPS stimulation for another 24 hr and measurement of IL-12p40 and IL-23

expression by relative quantitative real-time PCR (RQ-PCR) and ELISA. Interestingly, treatment with Jak inhibitor-I did not have an effect on either IL-12/23p40 or IL-23 expression (Figures 3.3.11). Taken together, my results suggest that IFN- γ /LPS-induced IL-12/23p40 and IL-23 expression in human MDMs is not regulated through either MAPK, PI3K or Jak/STAT pathways. It may be pointed out that similar concentrations of Jak inhibitor-I inhibited IL-4-induced CD44 expression in THP-1 cells ((data not shown and (188)).

Fig. 3.3.5 IFN- γ /LPS-induced IL-23 production is not regulated through the p38 MAPK pathway in human MDMs. MDMs were treated with increasing concentrations of p38 MAPK inhibitor, SB203580 (0-50 μ M) for 2 h followed by stimulation with IFN- γ (10 ng/ml, 16 h) and LPS (1 μ g/ml, 4 h) for quantification of IL-12p40 and IL-23p19 mRNA expression by RQ-PCR, whereas IL-12p40 and IL-23 protein production was determined by ELISA, IFN- γ (10 ng/ml, 16 h) and LPS (1 μ g/ml, 24 h). The results are shown as mean \pm SEM (n=7); * p < 0.05, Unstim- unstimulated.

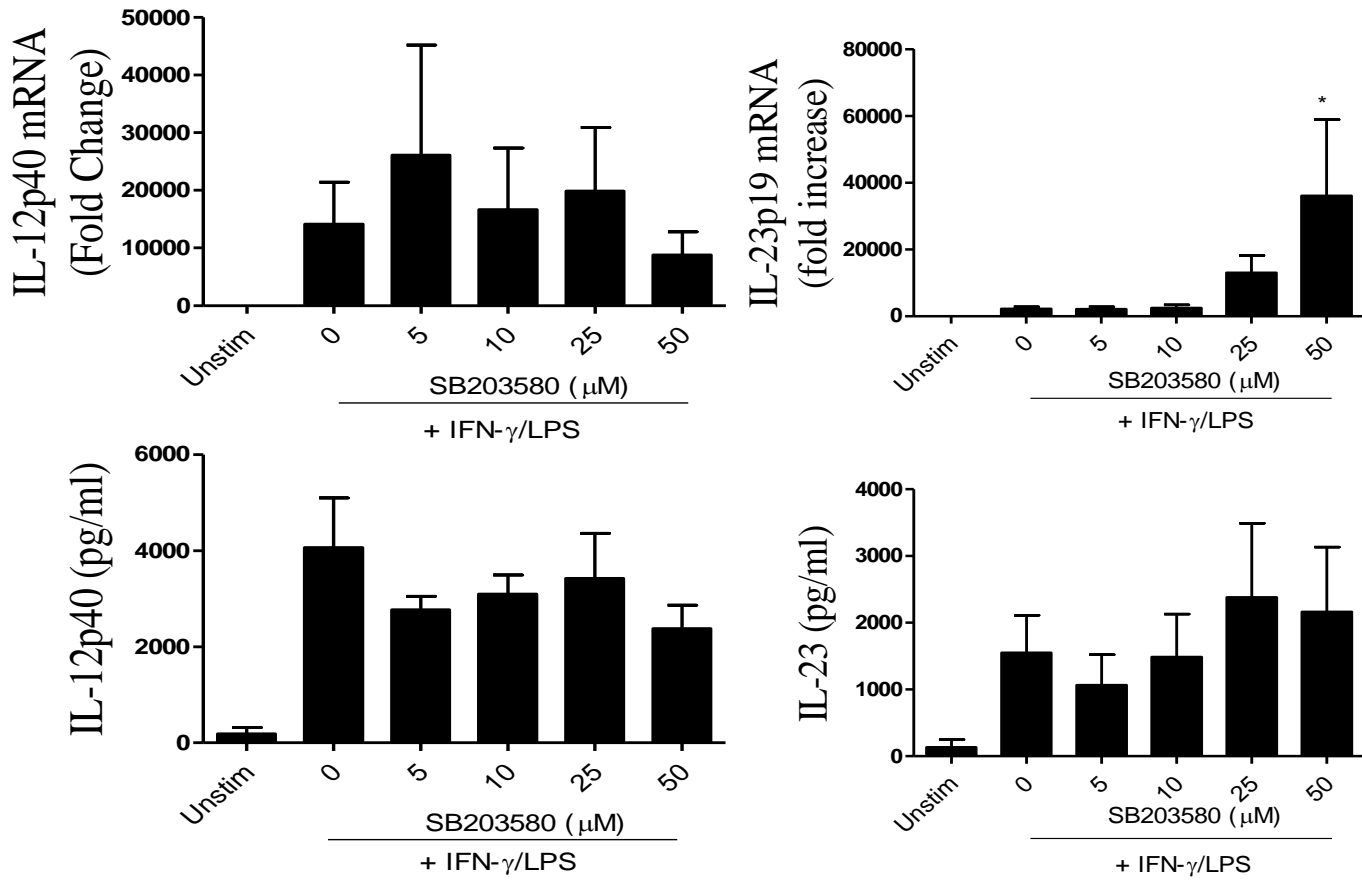

Figure 3.3.5

Fig. 3.3.6 LPS-induced IL-23 production is not regulated through the p38 MAPK pathway in human MDMs. MDMs were treated with increasing concentrations of p38 MAPK inhibitor, SB203580 (0-50 μ M) for 2 h followed by stimulation with LPS (1 μ g/ml, 24 h) for quantification of IL-12p40 and IL-23 protein production, determined by ELISA. The results are shown as mean \pm SEM (n=7); * $p < 0.05$, Unstim- unstimulated.

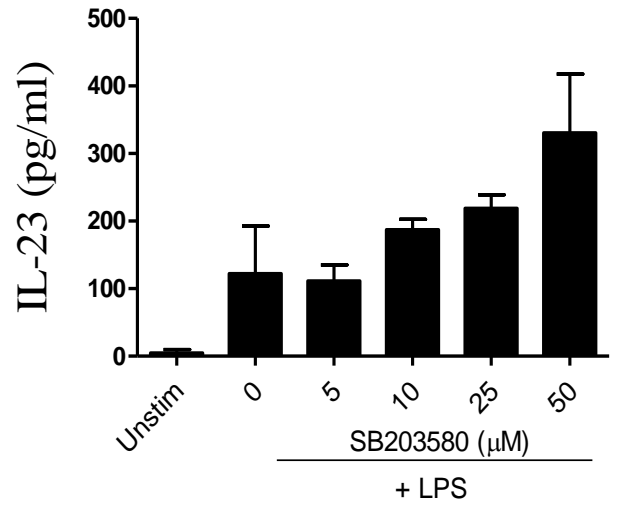
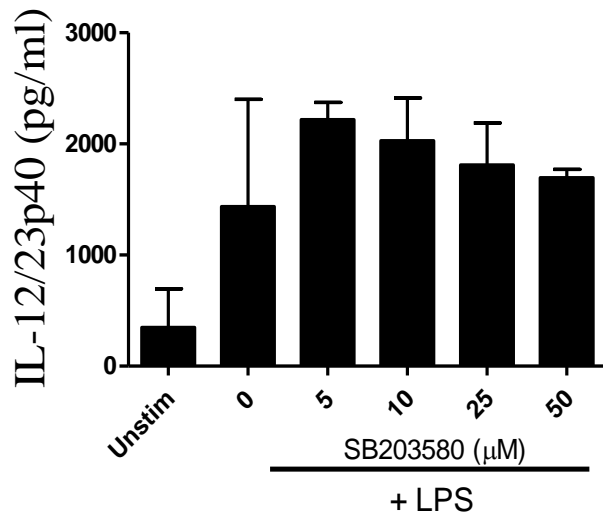

Figure 3.3.6

Fig. 3.3.7 IFN- γ /LPS-induced IL-23 production is not regulated through the ERK MAPK pathway in human MDMs. MDMs were treated with increasing concentrations of ERK MAPK inhibitor, PD98059 (0-50 μ M) for 2 h followed by stimulation with IFN- γ (10 ng/ml, 16 h) and LPS (1 μ g/ml, 4 h) for quantification of IL-12p40 and IL-23p19 mRNA expression by RQ-PCR, whereas IL-12p40 and IL-23 protein production was determined by ELISA, IFN- γ (10 ng/ml, 16 h) and LPS (1 μ g/ml, 24 h). The results are shown as mean \pm SEM (n=7), Unstim- unstimulated.

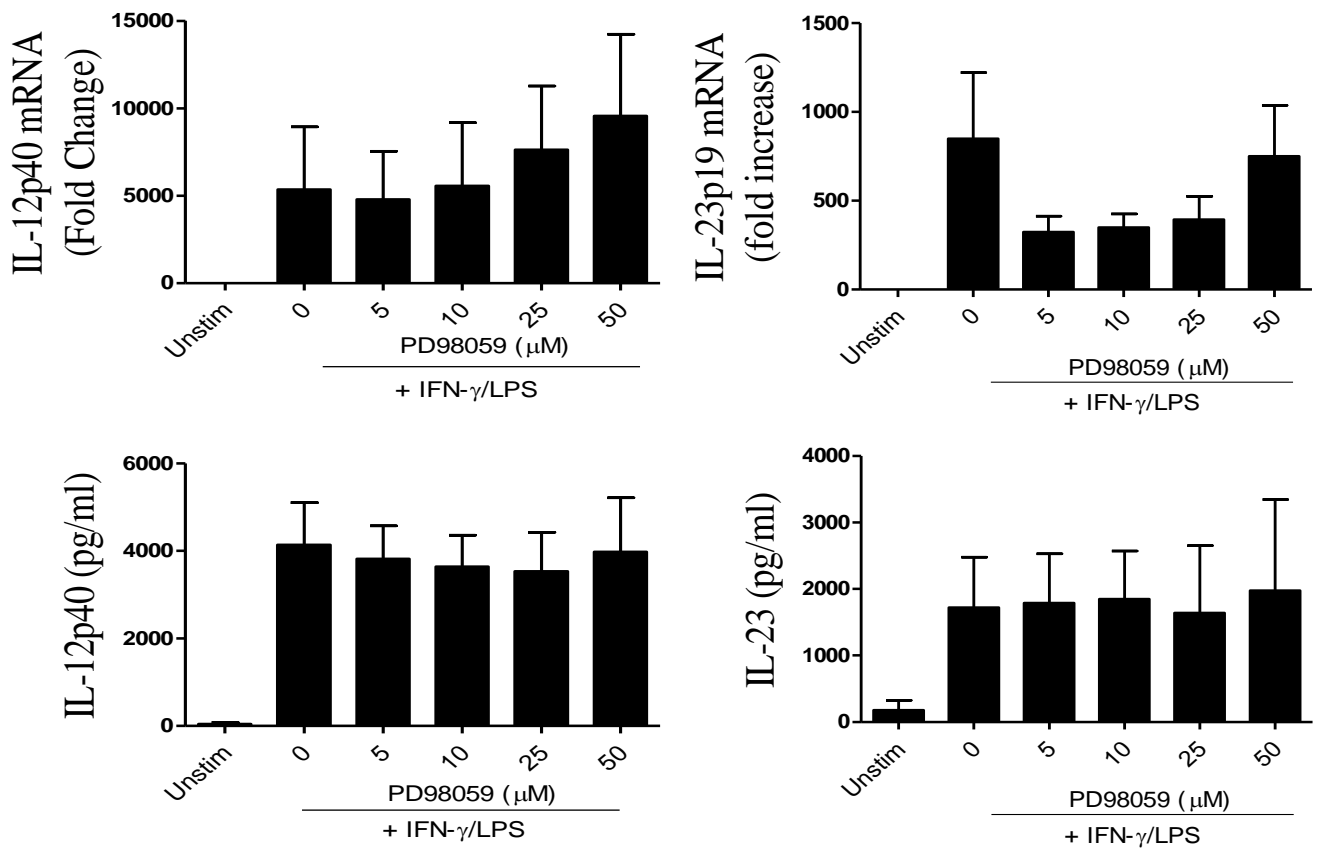

Figure 3.3.7

Fig. 3.3.8 LPS-induced IL-23 production is not regulated through the ERK MAPK pathway in human MDMs. MDMs were treated with increasing concentrations of ERK MAPK inhibitor, PD98059 (0-50 μ M) for 2 h followed by stimulation with LPS (1 μ g/ml, 24 h) for quantification of IL-12p40 and IL-23 protein production, determined by ELISA. The results are shown as mean \pm SEM (n=7), Unstim- unstimulated.

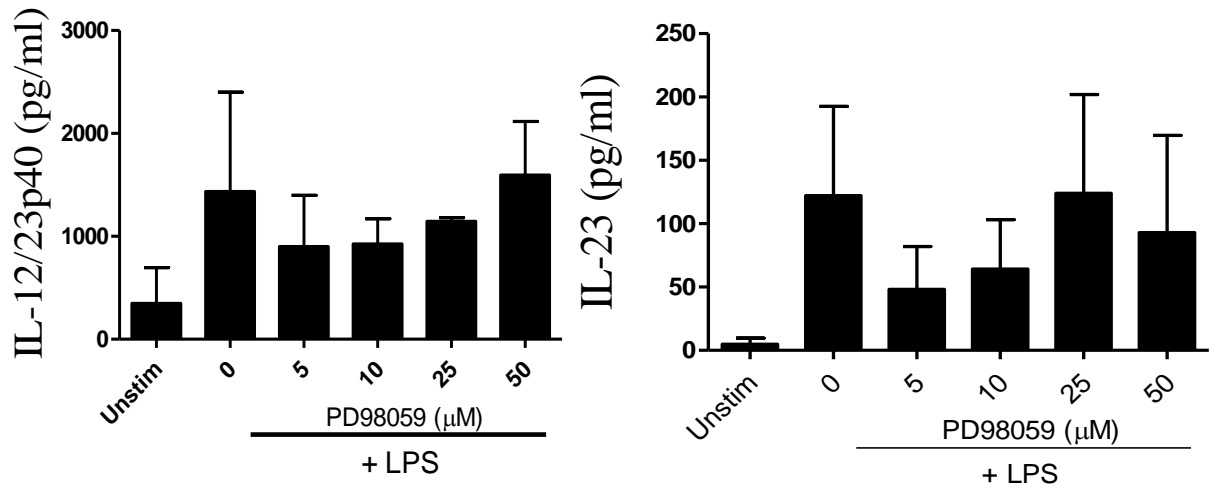

Figure 3.3.8

Fig. 3.3.9 IFN- γ /LPS-induced IL-23 production is not regulated through the PI3K pathway in human MDMs. MDMs were treated with increasing concentrations of PI3K inhibitor, LY294002 (0-50 μ M) for 2 h followed by stimulation with IFN- γ (10 ng/ml, 16 h) and LPS (1 μ g/ml, 4 h) for quantification of IL-12p40 and IL-23p19 mRNA expression by RQ-PCR, whereas IL-12p40 and IL-23 protein production was determined by ELISA, IFN- γ (10 ng/ml, 16 h) and LPS (1 μ g/ml, 24 h). The results are shown as mean \pm SEM (n=6), Unstim- unstimulated.

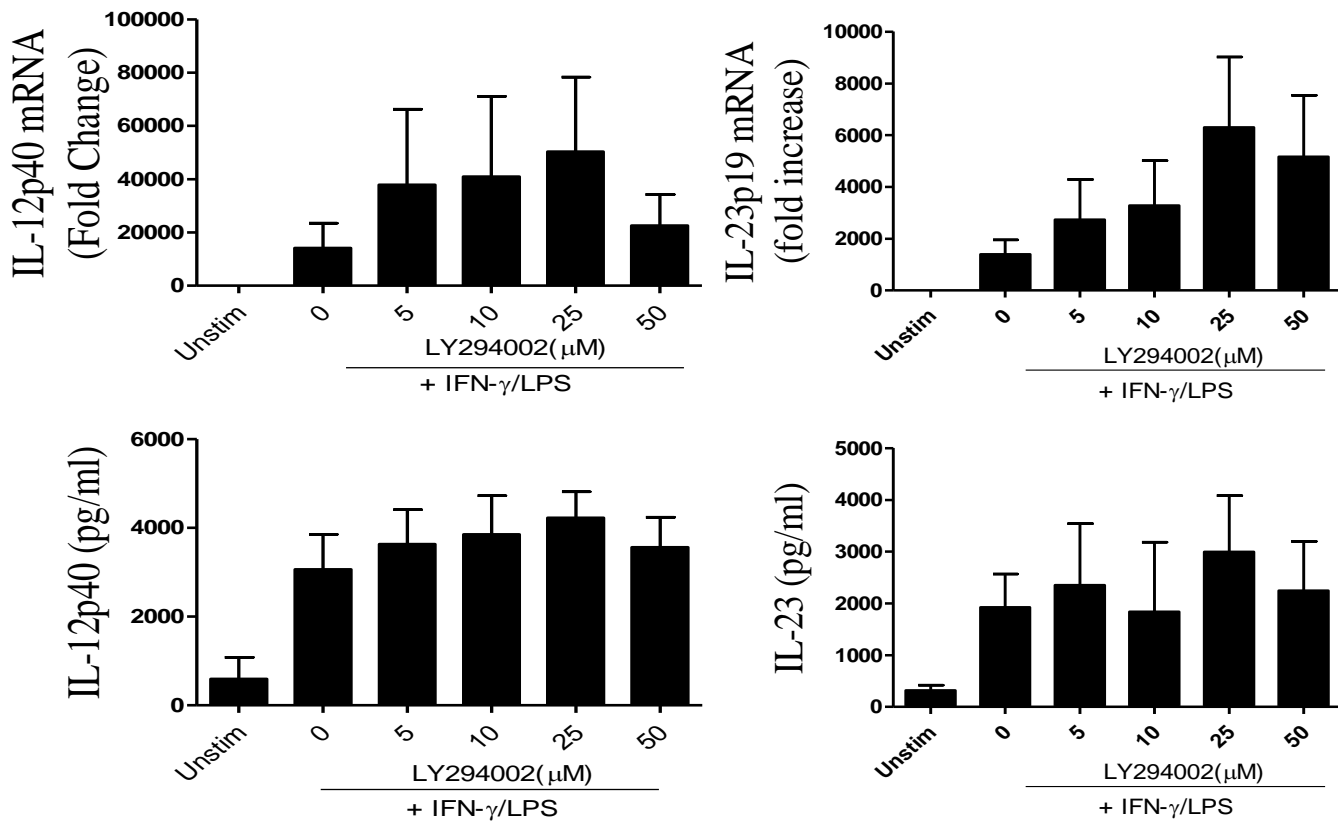

Figure 3.3.9

Fig. 3.3.10 LPS-induced IL-23 production is not regulated through the PI3K pathway in human MDMs. MDMs were treated with increasing concentrations of PI3K inhibitor, LY294002 (0-50 μ M) for 2 h followed by stimulation with LPS (1 μ g/ml, 24 h) for quantification of IL-12p40 and IL-23 protein production, determined by ELISA. The results are shown as mean \pm SEM (n=6), Unstim- unstimulated.

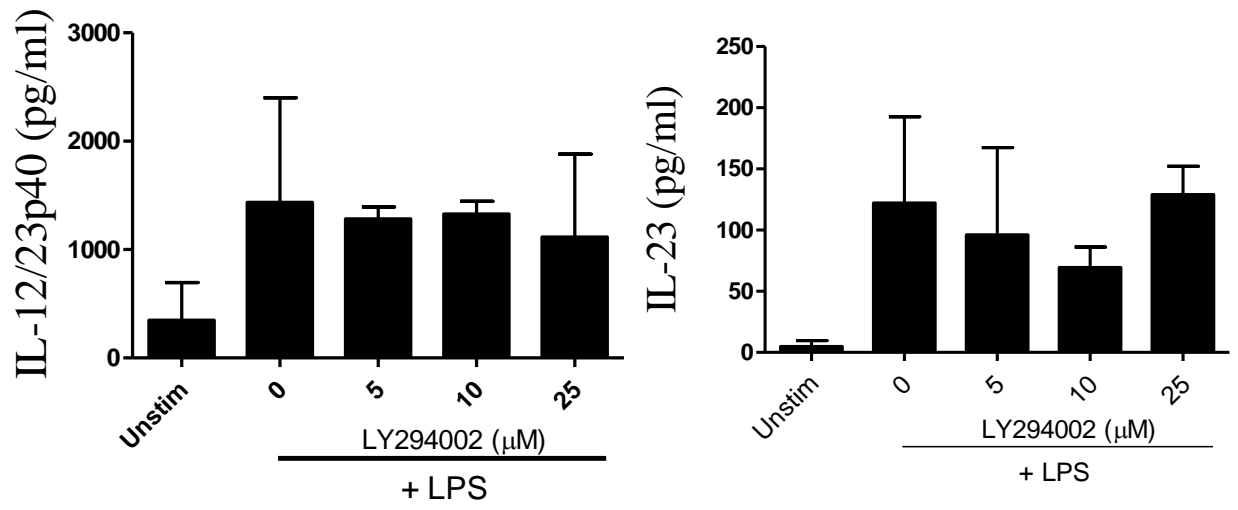

Figure 3.3.10

Fig. 3.3.11 IFN- γ /LPS-induced IL-23 production is not regulated through the JAK/STAT pathway in human MDMs. MDMs were treated with increasing concentrations of JAK/STAT inhibitor, JAK I inhibitor (0-100 μ M) for 2 h followed by stimulation with IFN- γ (10 ng/ml, 16 h) and LPS (1 μ g/ml, 4 h) for quantification of IL-12p40 and IL-23p19 mRNA expression by RQ-PCR, whereas IL-12p40 and IL-23 protein production was determined by ELISA, IFN- γ (10 ng/ml, 16 h) and LPS (1 μ g/ml, 24 h). The results are shown as mean \pm SEM (n=3), Unstim-unstimulated.

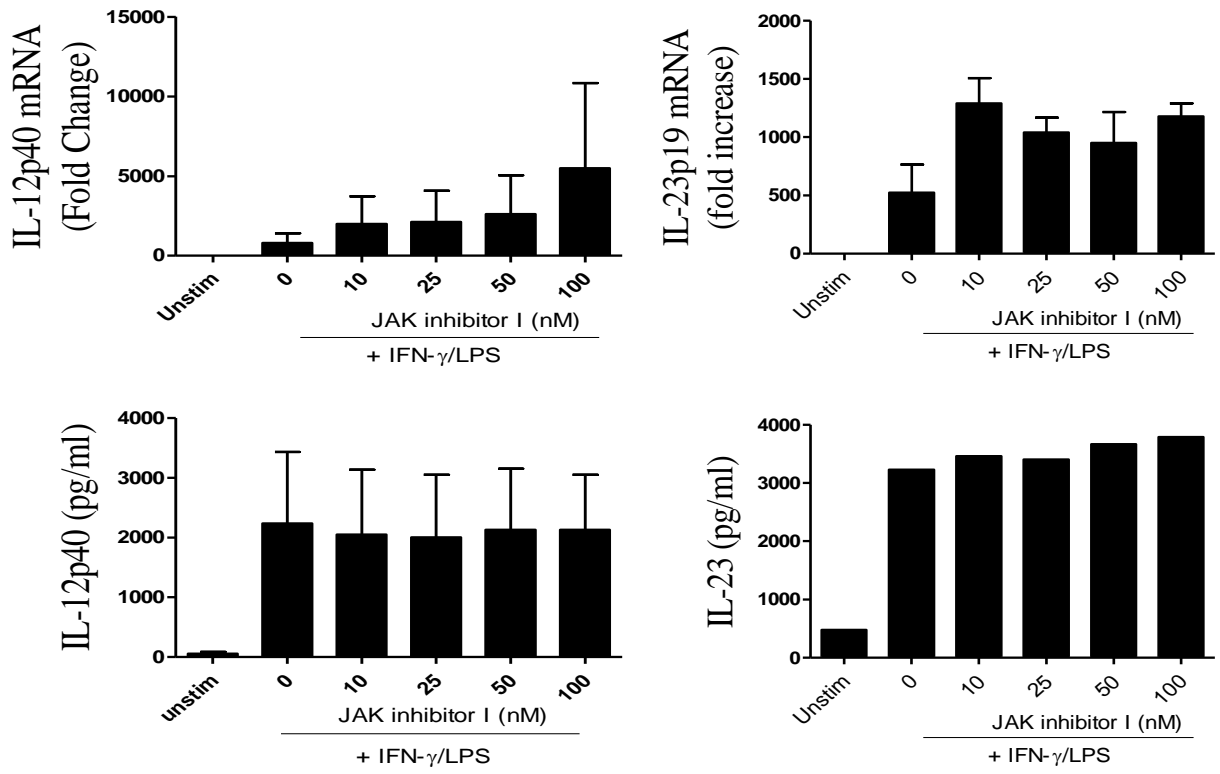

Figure 3.3.11

Chapter 4 Regulation of IFN- γ /LPS-induced IL-27 expression in myeloid cells

4.1 IFN- γ -induced IL-27 and IL-27p28 expression are differentially regulated through JNK MAPK and PI3K pathways independent of Jak/STAT in human monocytic cells

IL-27 is produced early during immune responses and acts as a bridge between the innate and adaptive immune systems (28, 197). It synergizes with IL-12 to increase IFN- γ production by naïve T cells and suppresses Th2-specific transcription factor GATA-3 (26, 63, 198). Given the importance of IL-27 in regulating host responses to invading pathogens, surprisingly very little is known about the molecular mechanisms governing its expression, particularly in humans. TLR-3, 4 and -7 ligands-activated JNK MAPK was shown to regulate IL-27 production in human and murine DCs (155). TLR-3 and-4 agonists upregulated IL-27p28 and EB13 expression through the induction of IFN- γ and interferon regulatory factor (IRF1) in human MDMs (155). Moreover, human macrophages stimulated by TLR-3, -4 and -7/8 ligands exhibited enhanced IL-27p28 expression mediated through IFN- α and IFN- α -activated IRF-1 (156).

Monocytes/macrophages and DCs can also be activated by IFN- γ to produce IL-12 family of cytokines, including IL-27 (26, 115, 154). Recently, IFN- γ was shown to induce IL-27 production in murine DCs (154, 159). Murugaiyan *et al.* identified a new pathway by which IFN- γ may limit IL-17-mediated inflammation through differential regulation of osteopontin and IL-27 production in DCs (115, 154). Although IFN- γ -induced enhancement of IL-12 production is well established (113, 115, 158), its role in IL-27 production and in particular the molecular signalling pathways involved in IFN- γ -induced IL-27 production in human and murine systems remains unknown. Understanding the molecular mechanisms

involved in the regulation of IL-27 production in humans is of critical significance to design therapeutic interventions that can be used clinically in the control of inflammatory, autoimmune and infectious diseases. Therefore, I investigated the molecular mechanisms governing the regulation of IL-27p28 and EBI3 gene expression and IL-27 protein production in human monocytes following stimulation with IFN- γ . My results suggest that IFN- γ -induced IL-27 production and IL-27p28 expression are distinctly regulated. IFN- γ -induced IL-27 production but not IL-27p28 expression is regulated through JNK MAPK and PI3K activation independent of the Jak/Stat signaling pathway.

IFN- γ induces IL-27 production in primary human monocytes

To determine whether IFN- γ can induce IL-27 expression in primary human monocytes, positively selected monocytes were stimulated with IFN- γ for 4-16 h and expression of IL-27 mRNA transcripts and IL-27 proteins was measured. Stimulation of positively selected monocytes with IFN- γ significantly induced the expression of IL-27p28 gene transcripts and IL-27 proteins, whereas IL-27 EBI-3 mRNA was not induced by IFN- γ stimulation (Fig 4.1.1A, B). Since I have observed that monocytes isolated by positive selection using anti-CD14 antibodies coated beads modulated the production of IL-23, I wanted to rule out the possibility that the same mechanism does not contribute to IFN- γ -induced IL-27 production. Therefore, to rule out the role of CD14 involvement in IFN- γ -induced IL-27 production, negatively selected monocytes were cultured with or without anti-CD14 antibody-coated beads for 1hr, followed by stimulation with IFN- γ . Interestingly, IFN- γ was able to induce production of IL-27 in both negatively selected monocytes cultured with anti-CD14 beads (Fig 4.1.2A) as well as in cells cultured without anti-CD14 beads (Fig

Fig. 4.1.1 IFN- γ induces IL-27 expression in primary human monocytes isolated by positive selection. Positively selected primary human monocytes (1×10^6 /ml) from healthy volunteers (n=6) were treated with IFN- γ (10 ng/ml) for 4 or 16 h. IL-27p28 and IL-27 EB13 mRNA expression were quantified by relative quantitative real-time PCR (n=3). The supernatants collected after 16 h stimulation were analyzed for IL-27 protein production by ELISA (n=11). The results are shown as mean \pm SEM, * p < 0.05; ** p < 0.01; *** p < 0.001, Unstim- unstimulated.

A.

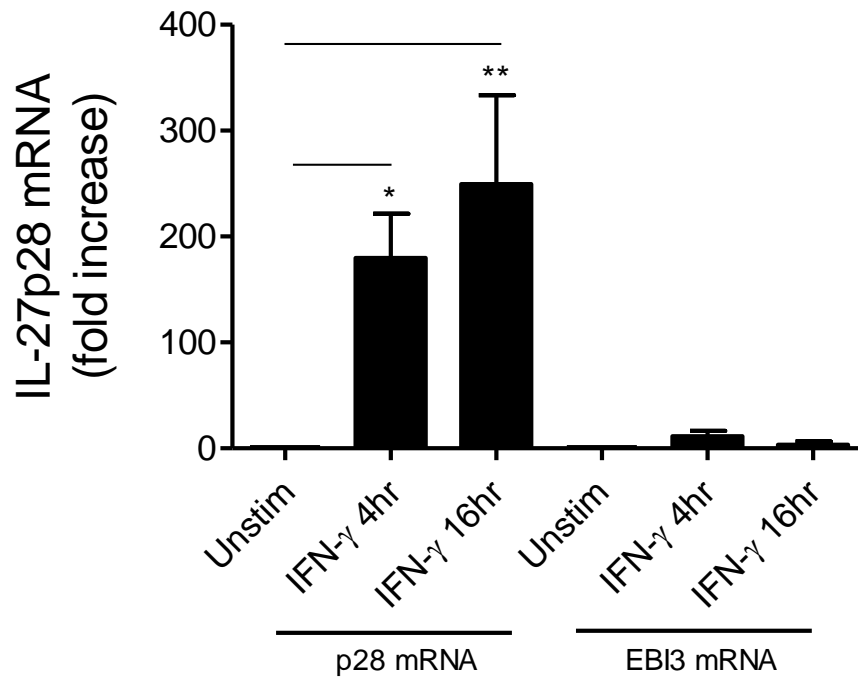

B.

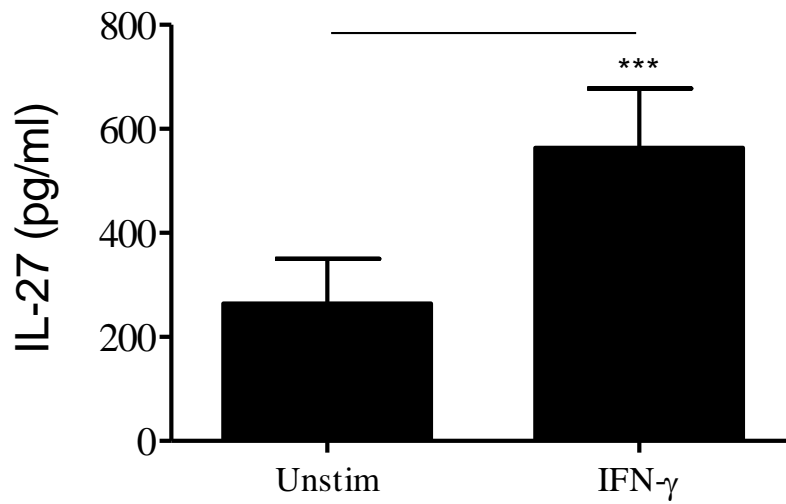

Figure 4.1.1

Fig. 4.1.2 IFN- γ stimulation of negatively selected monocytes and CD14-activated monocytes isolated by negative selection triggers IL-27 production. (A). Negatively selected human primary monocytes (1×10^6 /ml; n=4) were treated with IFN- γ (10 ng/ml, 16 h), or (B) cultured with microbeads conjugated with anti-CD14 antibodies and then stimulated with IFN- γ for 16 h. IL-27 protein production was determined by ELISA. The results are shown as mean \pm SEM, * $p < 0.05$, Unstim- unstimulated.

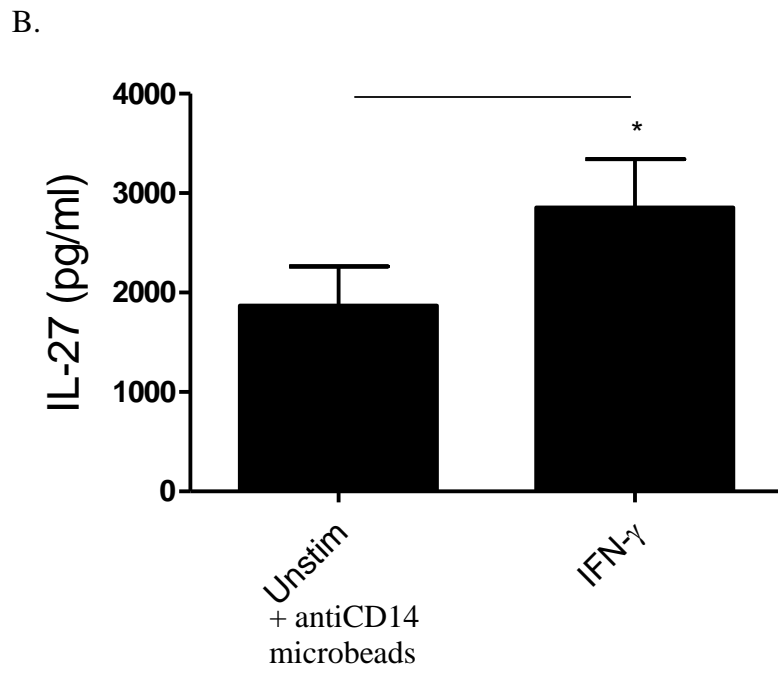
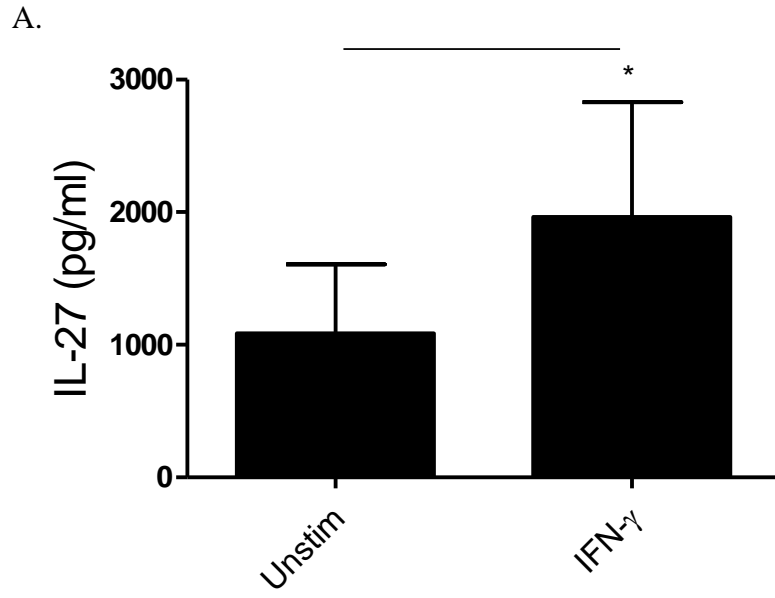

Figure 4.1.2

4.1.2B). The differences in the amount of secreted IL-27 in negatively selected monocytes (Figure 4.1.2) versus positively selected monocytes (Figure 4.1.2) might be attributed to the use of two different IL-27 ELISA reagents. Moreover, unstimulated primary monocytes produced a high basal level of IL-27 protein. These results indicate that IFN- γ can efficiently induce the expression of IL-27 mRNA subunits and protein in monocytes, independent of the mode of isolation. Hence, I focused my studies on the mechanism underlying the regulation of IL-27 in positively selected monocytes in response to IFN- γ stimulation.

IFN- γ -induced IL-27 production is not regulated by the Jak/Stat signaling pathway

Since IFN- γ primarily mediates its biological effects through the JAK-STAT pathway (199), I determined the involvement of IFN- γ -activated JAK/STAT pathway in the regulation of IL-27p28 mRNA and IL-27 protein production. The role of the JAK/STAT pathway was investigated by employing JAK inhibitor-I. Purified monocytes from healthy donors were treated with the JAK inhibitor-1 for 2 h, followed by stimulation with IFN- γ for 16hr for IL-27 mRNA and 24h for IL-27 protein production. The inhibition of JAK kinase did not affect IFN- γ -induced IL-27p28 mRNA transcripts or IL-27 production in human monocytes (Fig 4.1.3). The biological activity of JAK-inhibitor-1 was confirmed by studying its effect on STAT-1 phosphorylation (Fig 4.1.3, upper panel).

Fig. 4.1.3 IFN- γ -induced IL-27 production is not regulated by JAK/STAT pathway in human monocytes. Positively selected monocytes (1×10^6 /ml) were treated with increasing concentrations of Jak inhibitor I (0-100 nM) for 2 h followed by IFN- γ (10 ng/ml) stimulation for 15 min. Cell pellets were harvested for determination of STAT-1 phosphorylation by Western blot analysis. The result is a representative of 3 independent experiments (upper panel). Monocytes (1×10^6 /ml) were treated with increasing concentrations of Jak inhibitor I (0-100 nM) for 2 h followed by stimulation with IFN- γ (10 ng/ml) for 16 h for quantification of IL-27p28 mRNA expression (middle panel) or for proteins by ELISA (lower panel) (n=4). The results are shown as mean \pm SEM, * p < 0.05, Unstim- unstimulated.

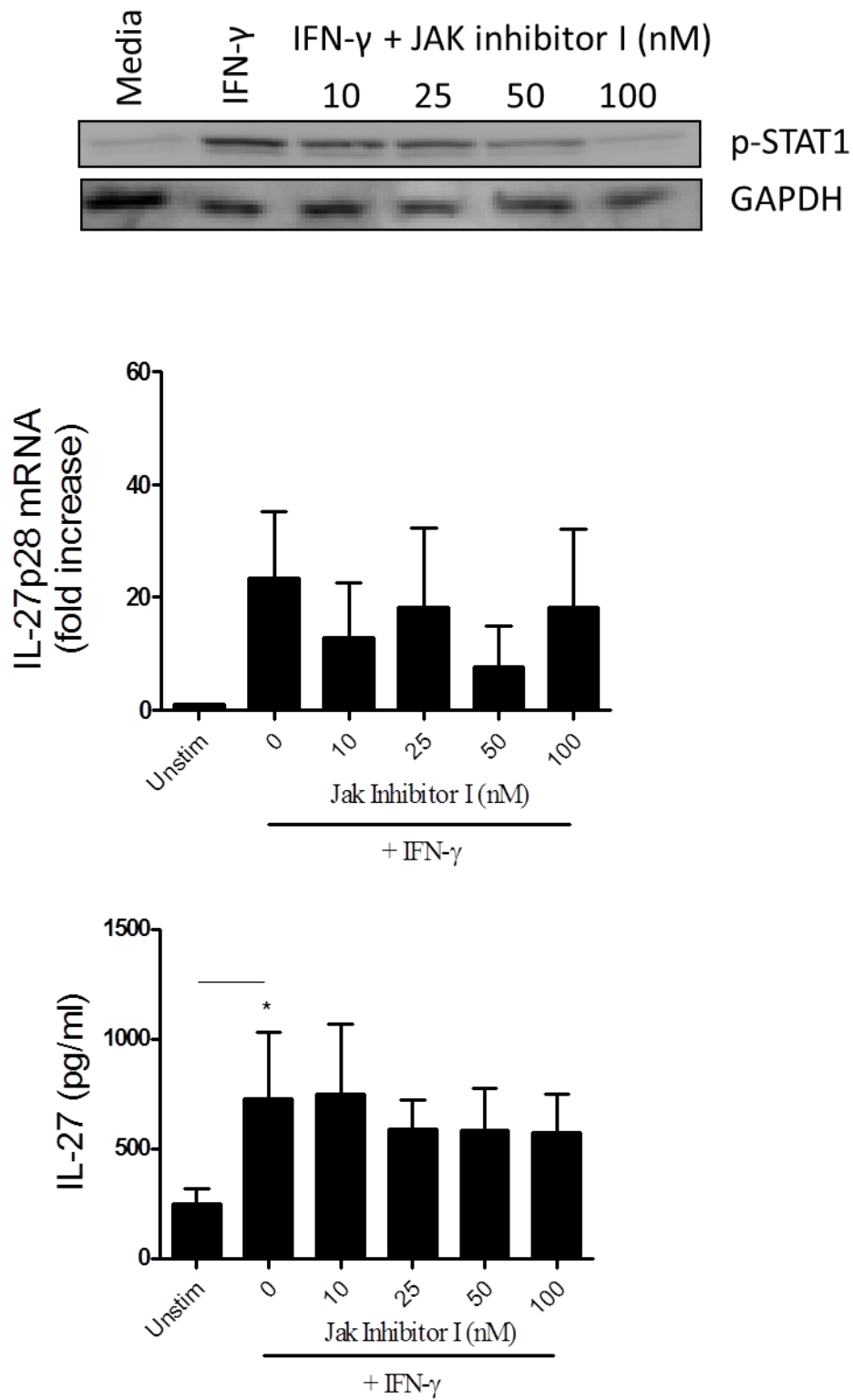

Figure 4.1.3

IFN- γ -induced IL-27 protein production is positively regulated by the JNK MAPK in monocytic cells

Since the Jak/STAT pathway was not involved in the regulation of IFN- γ -induced IL-27p28 and IL-27 protein production, and because IFN- γ is known to activate MAPKs and PI3K pathways (103-106), we investigated the role of MAPKs in the regulation of IL-27p28 mRNA and IL-27 expression in IFN- γ -stimulated monocytes by employing inhibitors specific for MAPKs (10, 110). For this, I first demonstrated that IFN- γ induced the phosphorylation of JNK, ERK or p38 MAPK and this phosphorylation was inhibited by their respective specific inhibitors as analyzed by Western immunoblotting (Figures 4.1.4, 4.1.5, 4.1.6 upper panels).

Monocytes were treated with SP600125, a JNK- specific inhibitor or SB203580, a p38 MAPK specific inhibitor, for 2 h followed by stimulation for 16 h with IFN- γ . Interestingly, SP600125 did not inhibit IFN- γ -induced IL-27p28 mRNA expression (Fig 4.1.4 middle panel). However, it significantly inhibited IFN- γ -induced IL-27 protein production in a dose-dependent manner in primary human monocytes (Fig 4.1.4 lower panel). SP600125 at concentrations of 25 μ M inhibited IFN- γ -induced IL-27 production to almost basal levels produced by unstimulated and untreated cells (Fig 4.1.4, lower panel). In contrast, SB203580 did not significantly inhibit IFN- γ -induced IL-27p28 mRNA expression, nor IL-27 protein production in human monocytes (Fig 4.1.5). In addition, inhibition of ERK MAPK by PD98059 did not affect the expression of either IL-27p28 mRNA, nor IL-27 protein levels in IFN- γ -stimulated monocytes (Fig 4.1.6). These results suggested that JNK positively regulates IFN- γ -induced IL-27 protein production but not IL-27p28 mRNA expression.

IFN- γ -induced IL-27 protein production is positively regulated through PI3K in human monocytes

To further understand the regulation of IFN- γ -induced IL-27 production, I have also examined the role of PI3K signaling pathway. For this, I examined whether Akt, the downstream mediator of PI3K signaling, is phosphorylated following IFN- γ -stimulation and whether this phosphorylation can be inhibited by the PI3K specific inhibitor, LY294002. Cells were pretreated with LY294002 for 2hr followed by stimulation with IFN- γ for 15 min. IFN- γ -induced the phosphorylation of Akt was inhibited by LY294002 in a dose-dependent manner (Fig 4.1.7, upper panel). To determine the role of PI3K in IFN- γ -induced IL-27 expression, monocytes were treated with LY294002 for 2 hr followed by IFN- γ for 16 hr. Inhibition of IFN- γ -induced IL-27 protein expression occurred without affecting IL-27p28 mRNA gene expression (Fig 4.1.7, middle panel). LY294002 at concentrations of 25 μ M inhibited IFN- γ -induced IL-27 production to basal levels produced by unstimulated and untreated cells (Fig 4.1.7, lower panel). Since IL-27p28 mRNA expression did not change following treatment with the inhibitors, I demonstrated the inhibitory effect of PI3K inhibitor on IL-27p28 and EBI-3 mRNA expression as well as IL-27 protein production in LPS-stimulated MDMs as a positive control (Fig 4.1.8). These results suggest that IFN- γ -induced IL-27 protein, but not IL-27p28 mRNA gene expression is positively regulated by the PI3K signalling pathway in primary human monocytes.

Fig 4.1.4 IFN- γ -induced IL-27 production is positively regulated through the JNK MAPK pathway in human monocytes. Positively selected monocytes (1×10^6 /ml) were treated with increasing concentrations of JNK MAPK inhibitor, SP600125 (0-50 μ M) for 2 h followed by IFN- γ (10 ng/ml) stimulation for 15 min (upper panel). Cell pellets were harvested for determination of JNK phosphorylation by Western blot analysis. The result is a representative of 3 independent experiments. Monocytes (1×10^6 /ml) were treated with increasing concentrations of SP600125 (0-50 μ M) for 2 h followed by stimulation with IFN- γ (10 ng/ml) for 16 h for quantification of IL-27p28 mRNA expression (middle panel) by RQ-PCR, whereas IL-27 protein production was determined by ELISA (lower panel). The results are shown as mean \pm SEM (n=4), * $p < 0.05$, Unstim- unstimulated.

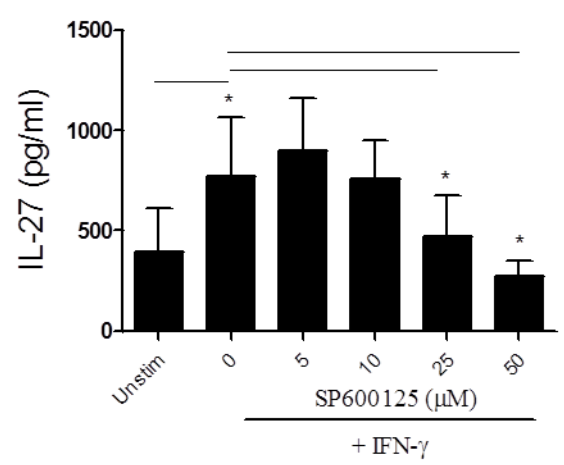
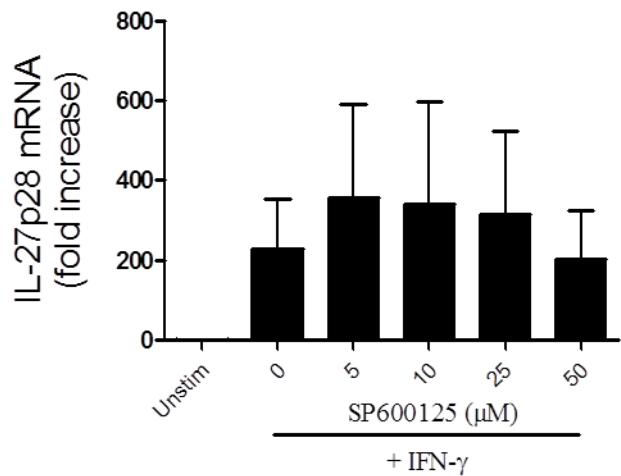
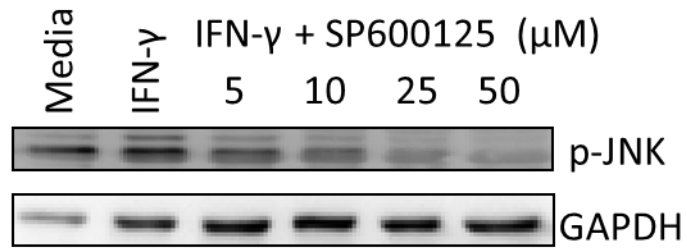

Figure 4.1.4

Fig 4.1.5 IFN- γ -induced IL-27 production is not regulated through the p38 MAPK pathway in human monocytes. Positively selected monocytes (1×10^6 /ml) were treated with increasing concentrations of JNK MAPK inhibitor, SB203580 (0-50 μ M) for 2 h followed by IFN- γ (10 ng/ml) stimulation for 15 min (upper panel). Cell pellets were harvested for determination of p38 phosphorylation by Western blot analysis. The result is a representative of 3 independent experiments. Monocytes (1×10^6 /ml) were treated with increasing concentrations of SB203580 (0-50 μ M) for 2 h followed by stimulation with IFN- γ (10 ng/ml) for 16 h for quantification of IL-27p28 mRNA expression by RQ-PCR (middle panel), whereas IL-27 protein production was determined by ELISA (lower panel). The results are shown as mean \pm SEM (n=4), Unstim- unstimulated.

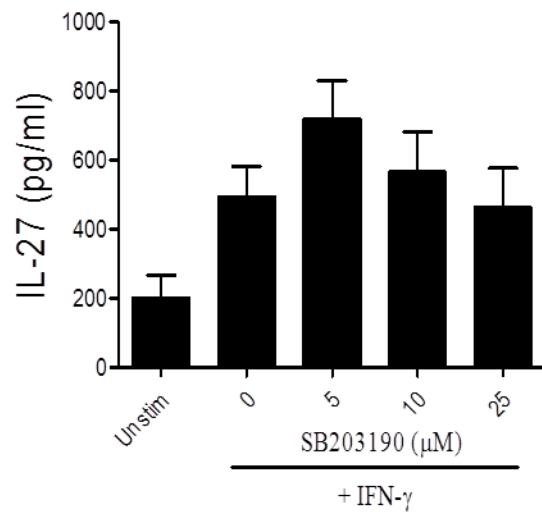
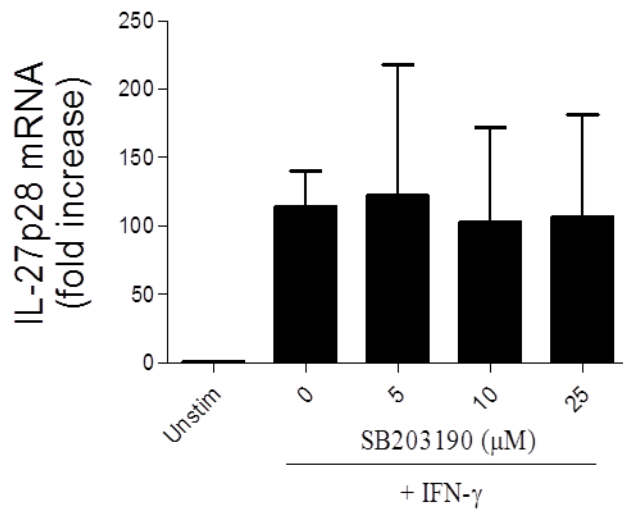
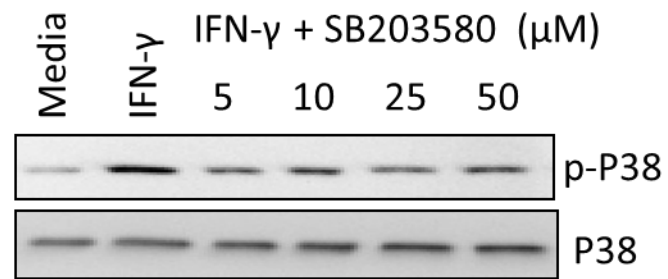

Figure 4.1.5

Fig 4.1.6 IFN- γ -induced IL-27 expression is not regulated by the ERK MAPK signaling pathway. Positively selected monocytes (1×10^6 /ml) were treated with increasing concentrations of PD98059 for 2 h followed by stimulation with IFN- γ (10 ng/ml, 16 h) for quantification of IL-27p28 mRNA expression by RQ-PCR (middle panel), whereas IL-27 protein production was determined by ELISA (lower panel). The results are shown as mean \pm SEM (n=3), Unstim- unstimulated.

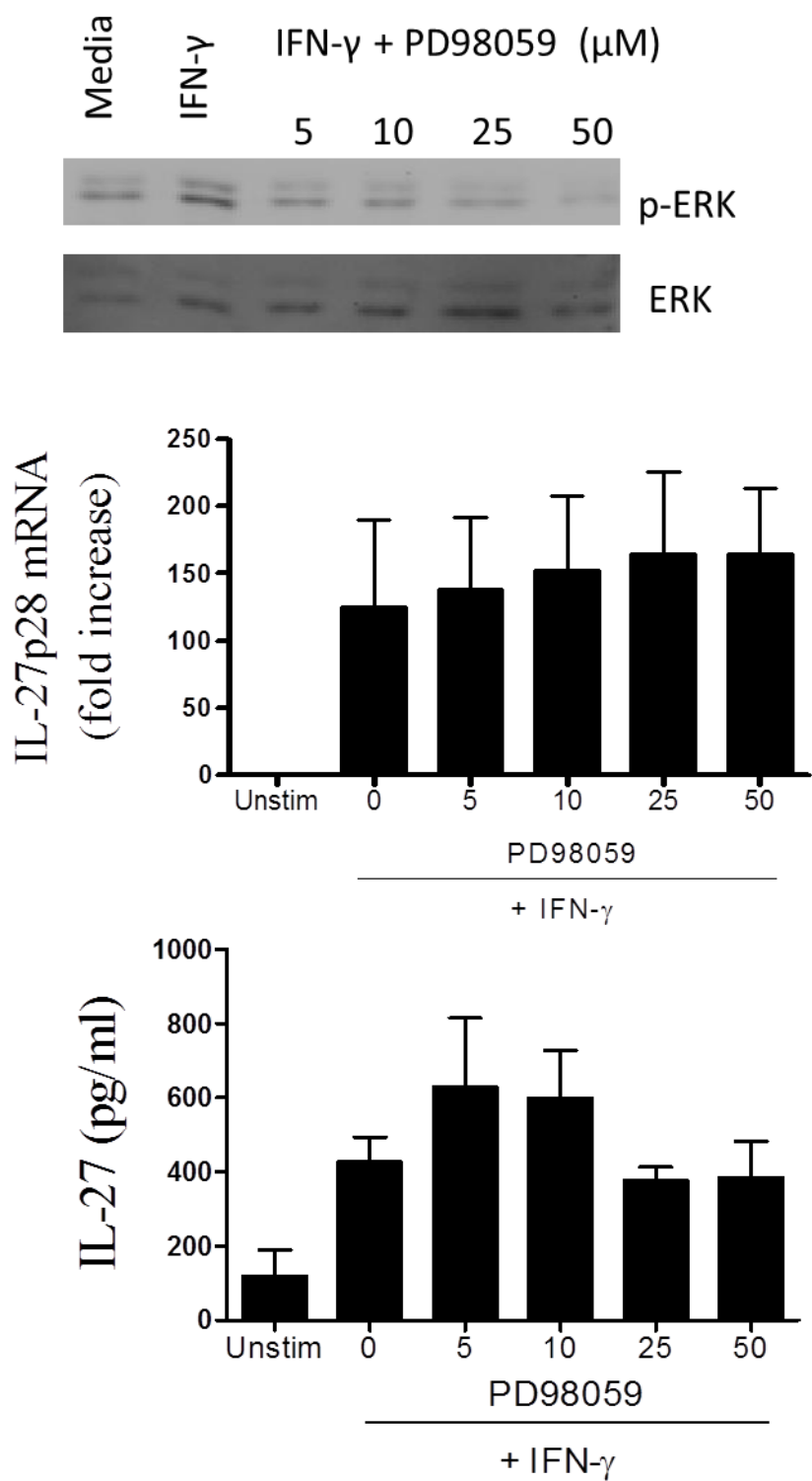

Figure 4.1.6

In summary, I investigated the molecular mechanism governing the regulation of IL-27p28 and EBI3 gene expression and IL-27 protein production in human monocytes following stimulation with IFN- γ . Collectively, my results suggest that IFN- γ -induced IL-27 production and IL-27p28 mRNA expression are distinctly regulated. IFN- γ -induced IL-27 production, but not IL-27p28 mRNA expression is positively regulated through JNK MAPK and PI3K activation independent of the Jak/Stat signaling pathway.

Fig 4.1.7 IFN- γ -induced IL-27 production is positively regulated through the PI3K pathway in human monocytes. Positively selected monocytes (1×10^6 /ml) were treated with increasing concentrations of PI3K inhibitor, LY294002 (0-50 μ M) for 2 h followed by IFN- γ (10 ng/ml) stimulation for 15 min (upper panel). Cell pellets were harvested for determination of Akt phosphorylation by Western blot analysis. The result is a representative of 3 independent experiments. Monocytes (1×10^6 /ml) were treated with increasing concentrations of PI3K inhibitor, LY294002 (0-50 μ M) for 2 h followed by stimulation with IFN- γ (10 ng/ml) for 16 h for quantification of IL-27p28 mRNA expression by RQ-PCR (middle panel), whereas IL-27 protein production was determined by ELISA (lower panel). The results are shown as mean \pm SEM (n=5), * p < 0.05, Unstim- unstimulated.

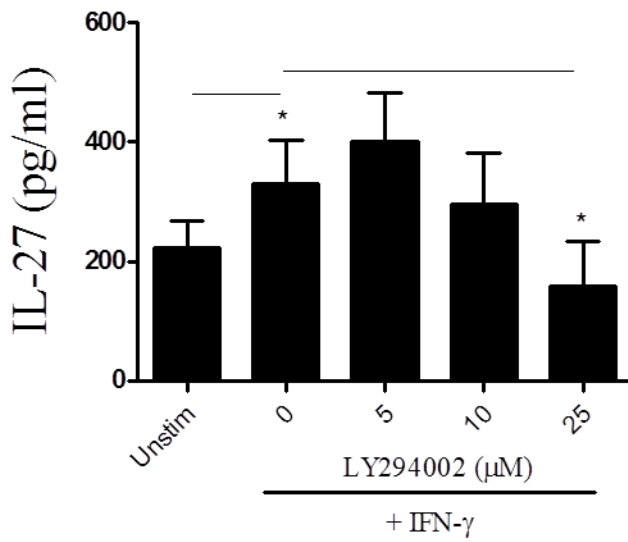
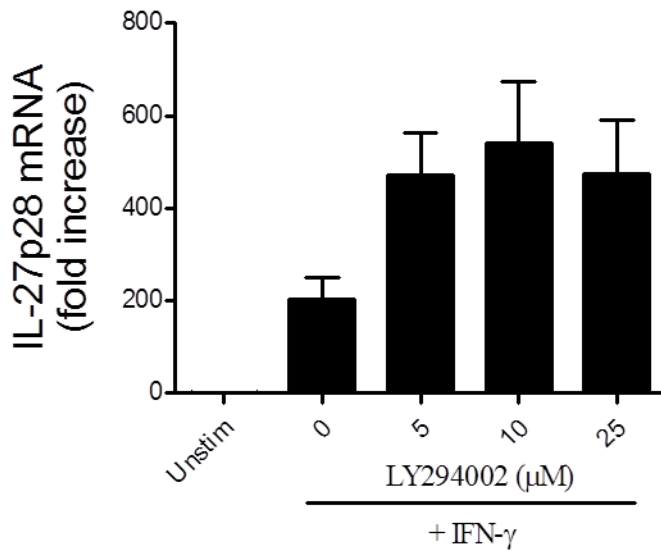
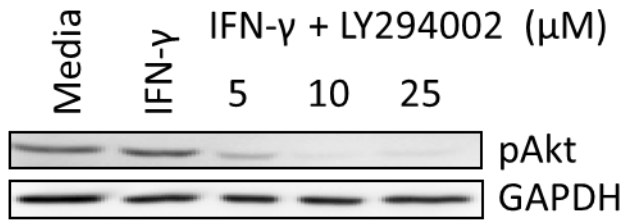

Figure 4.1.7

Fig 4.1.8 LPS-induced IL-27 production is positively regulated through the PI3K pathway in THP-1 cells. THP-1 (1×10^6 /ml) were treated with increasing concentrations of PI3K inhibitor, LY294002 (0-50 μ M) for 2 h followed by stimulation with LPS (1 μ g/ml, 4 h) for quantification of IL-27p28 and EB13 mRNA expression by RQ-PCR, whereas IL-27 protein production was determined by ELISA, LPS (1 μ g/ml, 24 h). The results are shown as mean \pm SEM (n=3), Unstim- unstimulated.

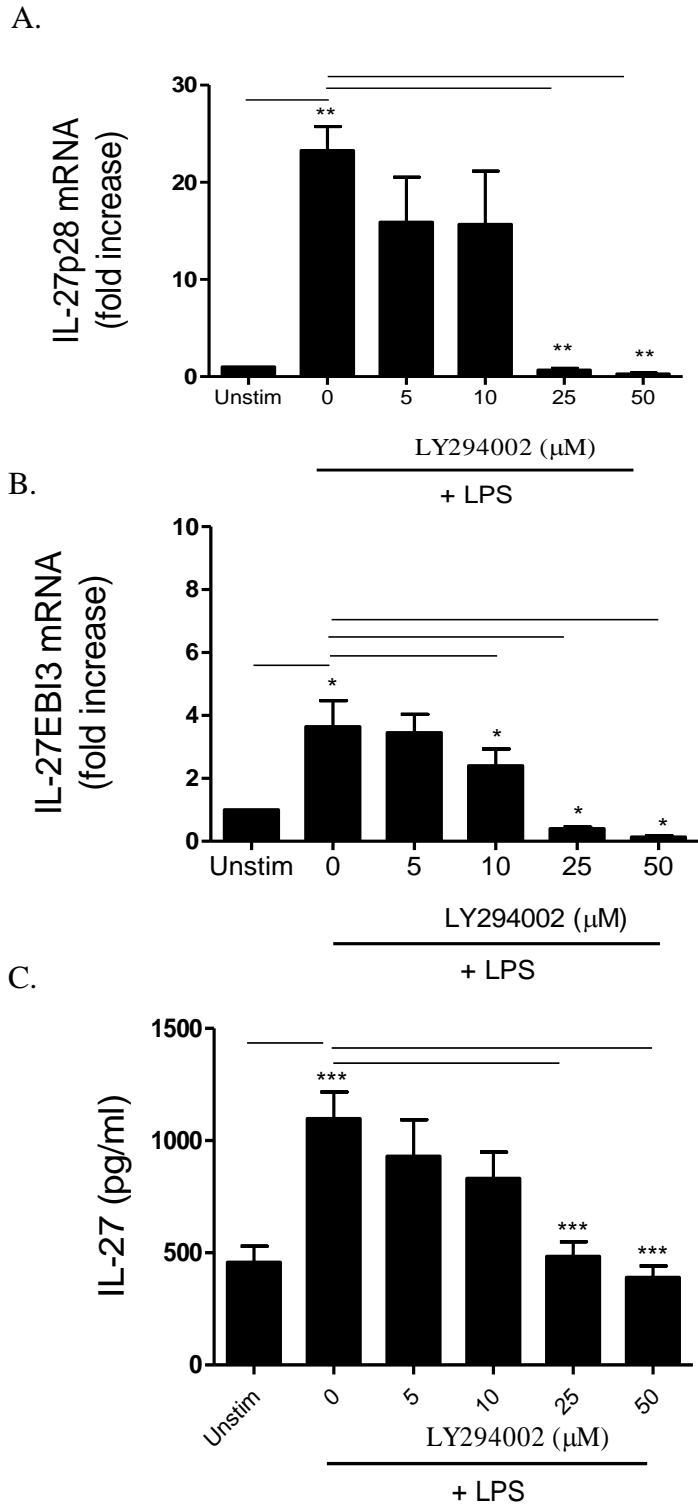

Figure 4.1.8

4.2 LPS-induced IL-27 and IL-27p28 expression are differentially regulated through JNK, p38 MAPK and PI3K pathways in THP-1 cells and MDMs

IL-27 is produced by activated APCs in response to microbial infections or TLR ligands (26, 70, 90, 154). Human studies have shown that macrophages and DCs co-expressed production of IL-27p28 and EBI3, two components of heterodimeric IL-27. Furthermore, the highest levels of p28 and EBI3 mRNA expression were found in monocytes and monocyte-derived DCs (26, 90). TLR-activated signaling pathways have been implicated in the regulation of IL-27 production. For example, Theiler's murine encephalomyelitis virus-induced expression of IL-27p28 in RAW264.7, a mouse macrophage cell line, was shown to be dependent on TLR3- and TLR7-induced activation of JNK MAPK (148). In addition, murine bone marrow-derived macrophages stimulated by *Salmonella enteritidis* or LPS, expressed IL-27 subunits via the activation of TLR4/MyD88 signalling pathway (84, 147, 156). Moreover, TLR-2, TLR-4 and TLR-9 ligands were shown to upregulate IL-27EBI3 expression in mouse splenic DCs through MyD88, and NF κ B activation (154). TLR-3 and-4 agonists upregulated IL-27p28 and EBI3 expression through the induction of IFN- γ and interferon regulatory factor (IRF1) in human MDMs (155). Human macrophages stimulated by TLR-3, -4 and -7/8 ligands exhibited enhanced IL-27p28 expression mediated through IFN- α and IFN- α -activated IRF-1 (156).

LPS is the best characterized monocytic mitogen and can activate cells of the monocytic lineage to produce various immunoregulatory and proinflammatory cytokines. The mechanism by which LPS induces the production of several cytokines has been investigated. The interaction of LPS with its cognate receptor, CD14 expressed on monocytes, activates a series of intracellular signaling molecules, such as myeloid differentiation factor 88 (MyD88) (200), which in turn triggers a downstream signal that

ultimately activates cytoplasmic kinases, such as MAPKs and PI3K (200). These events result in the production of several proinflammatory cytokines, including IL-12 and IL-27. In fact, I have already demonstrated that IL-12p40 and IL-23 production is regulated by three distinct signaling pathways including JNK MAPK, p38 MAPK and PI3K in LPS-stimulated THP-1 cells.

IFN- γ -induced enhancement of IL-12 production is well established (113, 115, 158). In the section 4.1 of this thesis, I have shown that IFN- γ can induce the expression of IL-27 and its subunit IL-27p28 in primary human monocytes. However, IFN- γ -induced IL-27 production and IL-27p28 mRNA expression were found to be distinctly regulated. IFN- γ -induced IL-27 production, but not IL-27p28 expression was regulated through JNK MAPK and PI3K activation independent of the Jak/Stat signaling pathway. Given the importance of the role that IL-27 has in regulating host responses to invading pathogens (26), and how little it is known about its regulation, I undertook the present study to investigate the mechanisms that control IL-27 production in human MDMs and THP-1 cells after their activation by LPS and/or IFN- γ . My results suggest that LPS can induce IL-27 expression in THP-1 cells and MDMs. Priming with IFN- γ was found to enhance IL-27 production in LPS-stimulated MDMs. Experiments designed to understand the signaling pathways involved in the regulation of IL-27 suggest that LPS- and LPS/IFN- γ -induced IL-27 expression in MDMs and LPS-induced IL-27 production in THP-1 cells was regulated through the activation of JNK and p38 MAPKs and PI3K. IFN- γ and LPS-induced IL-27 expression in human monocytic cells was also regulated by the PI3K and JNK MAPKs and independent of the Jak/Stat signaling pathway.

LPS- and IFN γ /LPS induce IL-27 production in THP-1 cells and MDMs

First, I confirmed that LPS induces IL-27 expression in human MDMs and THP-1 cells. LPS upregulated IL-27p28 and IL-27EBI3 gene expression in THP-1 (Figure 4.2.1), as well as in MDMs (Figure 4.2.2). Unlike in primary monocytes, IFN- γ only modestly upregulated IL-27p28 and EBI-3 mRNA, but failed to induce IL-27 secretion in THP-1 cells (Fig 4.2.1). Although, IFN- γ upregulated IL-27p28 and EBI-3 mRNA, it failed to induce IL-27 expression in MDMs (Fig 4.2.2). I and others have shown that optimal expression of IL-23p19 and IL-12/23p40 mRNA has been shown to require priming by IFN- γ for 8-16 hr prior to LPS stimulation (158). Therefore, I hypothesized that similar priming with IFN- γ may also induce IL-27 production in human MDMs and THP-1 cells. Human MDMs were stimulated with IFN- γ (10 ng/ml, 16 hr) followed by LPS stimulation for another 4 and 24 hr in order to measure IL-27p28 mRNA transcripts and IL-27 proteins, respectively. Stimulation with IFN- γ and LPS together significantly induced the expression of IL-27p28 mRNA transcripts in THP-1 cells (Fig 4.2.1) and EBI3 mRNA in MDMs (Fig 4.2.2). Although IL-27 production following IFN- γ /LPS stimulation was higher than that induced by LPS alone in both THP-1 and MDMs, it was not found to be statistically significant. (Fig 4.2.1 and 4.2.2). These results suggest that priming of THP-1 cells and MDMs with IFN- γ prior to LPS stimulation enhanced expression of IL-27 and its subunits. In order to further understand how IFN- γ -priming induces IL-27 expression, I focused my studies on the regulation of IFN- γ /LPS-induced IL-27 production.

Fig. 4.2.1 LPS and IFN- γ /LPS induce IL-27 expression in the pro-monocytic cell line, THP-1. THP-1 cells (1×10^6 /ml) were treated with IFN- γ (10 ng/ml, 16 h) followed by LPS (1 μ g/ml, 4 h). IL-27p28 and IL-27 EBI3 mRNA expression were quantified by relative quantitative real-time PCR (upper and middle panels). Cells (1×10^6 /ml) were treated with IFN- γ (10 ng/ml, 16 h) followed LPS (1 μ g/ml, 24 h) and IL-27 protein production was determined by ELISA. The results are shown as mean \pm SEM (n=4), * p < 0.05; ** p < 0.01; *** p < 0.001, Unstim- unstimulated. Results were generated by Dr. Ali R. Rahimi.

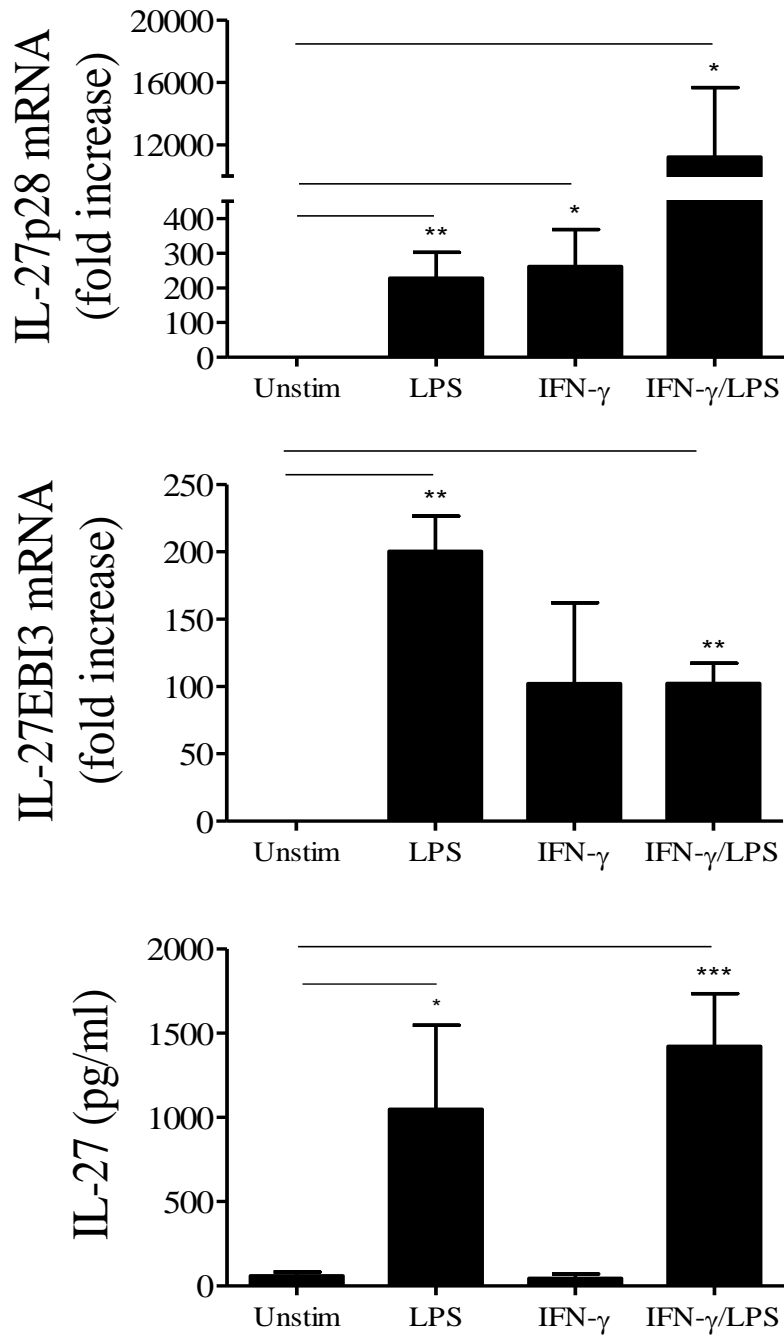

Figure 4.2.1

Fig. 4.2.2 LPS and IFN- γ /LPS induce IL-27 expression in monocyte-derived macrophages. MDMs were treated with IFN- γ (10 ng/ml, 16 h) followed by LPS (1 μ g/ml, 4 h). IL-27p28 and IL-27 EB13 mRNA expression were quantified by relative quantitative real-time PCR (upper and middle panels). Cells were treated with IFN- γ (10 ng/ml, 16 h) followed by LPS (1 μ g/ml, 24 h) and IL-27 protein production was determined by ELISA. The results are shown as mean \pm SEM (n=8), * p < 0.05; ** p < 0.01; *** p < 0.001, Unstim- unstimulated.

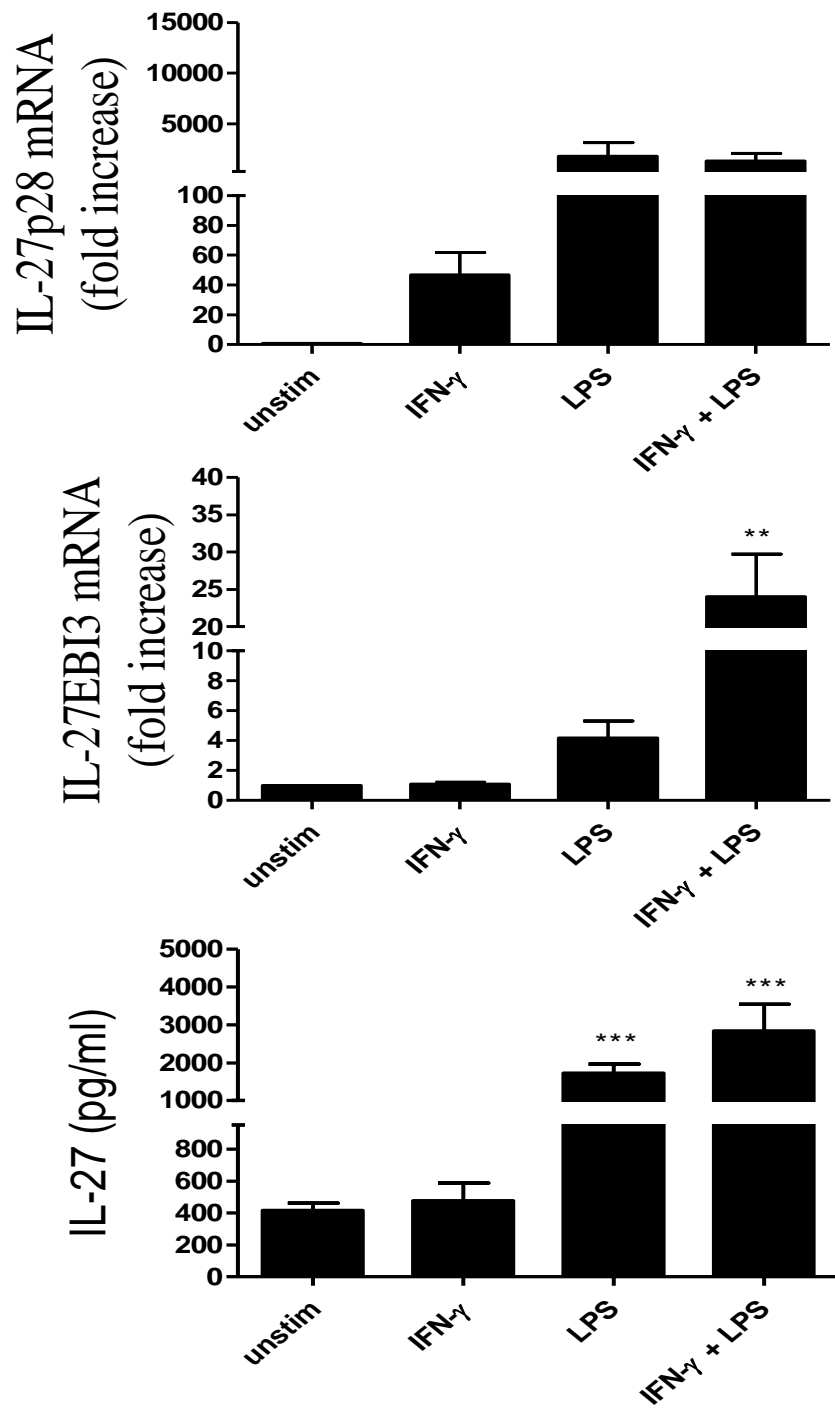

Figure 4.2.2

IFN γ /LPS-induced IL-27 production is positively regulated through JNK and p38 MAPK signaling pathway in THP-1 cells and MDMs

To gain insight into the mechanism of IFN γ /LPS-induced IL-27 production, I determined the role of MAPKs in the regulation of IL-27p28 and IL-27 expression in MDMs and THP-1 cells. For this, I employed MAPK specific inhibitors SB203580, PD98059 and SP600125. Cells were cultured with increasing concentrations of each MAPK inhibitor and stimulated with LPS alone or with both IFN- γ and LPS followed by quantification of IL-27p28 mRNA expression by real-time PCR and ELISA. To determine the role of MAPKs signaling, first I confirmed that LPS can induce phosphorylation of JNK, ERK and p38 MAPK and this phosphorylation can be downregulated by their specific inhibitors in THP-1 cells (Figure 4.2.2).

These inhibitors were then used to examine their effect on the involvement of MAPKs in LPS-induced IL-27 in THP-1 cells. In LPS-stimulated THP-1 cells, inhibition of JNK MAPK did not affect IL-27p28 mRNA levels (Figure 4.2.3 upper panel), whereas it significantly inhibited IL-27 production (Figure 4.2.3 lower panel). In contrast, inhibition of p38 MAPK significantly decreased in a dose-dependent manner both IL-27p28 mRNA expression as well as IL-27 production (Figure 4.2.5 middle and lower panels).

The role of JNK and p38 MAPK in LPS-induced IL-27 protein production was further confirmed using siRNA to inhibit these signalling proteins (Figures 4.2.4 and 4.2.6). THP-1 cells were transfected with either JNK or p38 MAPK specific siRNAs for 24hr, followed by stimulation with LPS for 15-30 min for the detection of p38 and JNK phosphorylation by Western blot analysis. Cells were also stimulated with LPS for 4hr for the detection of IL-27p28mRNA or 24 hr for IL-27 protein production by ELISA. Cells

Fig. 4.2.3 LPS-induced IL-27 production is positively regulated through the JNK MAPK pathway in THP-1 cells. THP-1 (1×10^6 /ml) were treated with increasing concentrations of JNK MAPK inhibitor, SP600125 (0-50 μ M) for 2 h followed by stimulation with LPS (1 μ g/ml, 4 h) for quantification of IL-27p28 mRNA expression by RQ-PCR, whereas IL-27 protein production was determined by ELISA, LPS (1 μ g/ml, 24 h). The results are shown as mean \pm SEM (n=4), * $p < 0.05$, Unstim- unstimulated. Results were generated by Dr. Ali R. Rahimi.

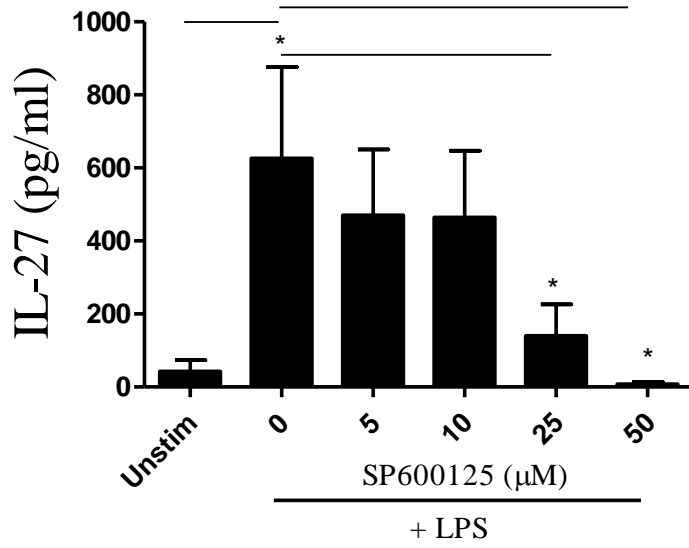
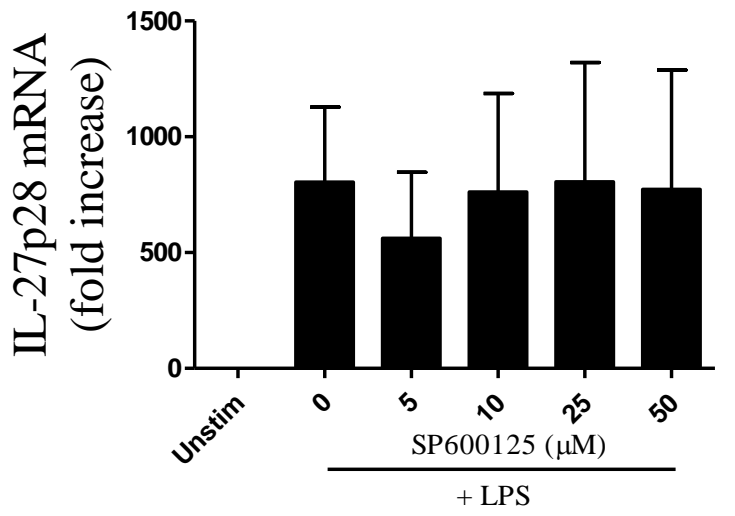

Figure 4.2.3

Fig. 4.2.4 JNK MAPK siRNA inhibits LPS-induced IL-27 expression in THP-1 cells.

THP-1 cells (2.5×10^5) were transfected with the either control siRNA or JNK MAPK siRNA for 24 hours followed by stimulation with LPS ($1 \mu\text{g/ml}$) for 30 minutes for the determination of phosphorylated JNK MAPK by Western blot analysis. The result is a representative of 3 independent experiments. THP-1 cells were transfected with the either control siRNA or JNK MAPK siRNA for 24 h followed by stimulation with LPS ($1 \mu\text{g/ml}$) for 4h for quantification of IL-27p28 mRNA expression by RQ-PCR assessment, or 24h of IL-27 protein production by ELISA. The results are shown as mean \pm SEM (n=5); * p < 0.05, ctrl – control siRNA.

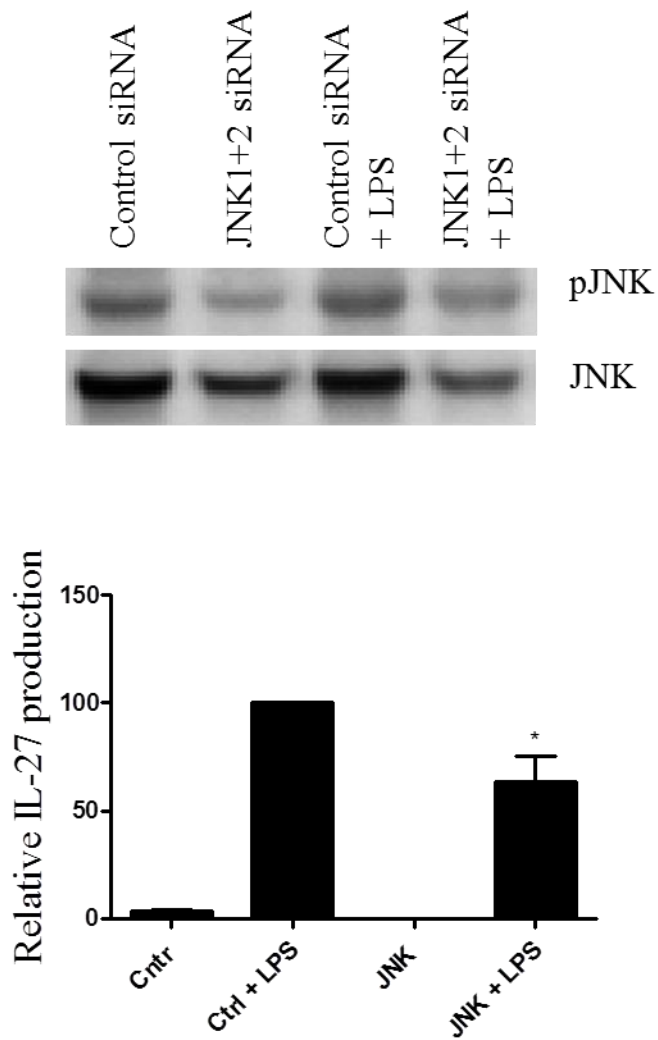

Figure 4.2.4

Fig. 4.2.5 LPS-induced IL-27 production is positively regulated through the p38 MAPK pathway in THP-1 cells. THP-1 (1×10^6 /ml) were treated with increasing concentrations of p38 MAPK inhibitor, SB203580 (0-50 μ M) for 2 h followed by stimulation with LPS (1 μ g/ml, 4 h) for quantification of IL-27p28 mRNA expression by RQ-PCR, whereas IL-27 protein production was determined by ELISA, LPS (1 μ g/ml, 24 h). The results are shown as mean \pm SEM of 3 independent experiments. Results were generated by Dr. Ali R. Rahimi.

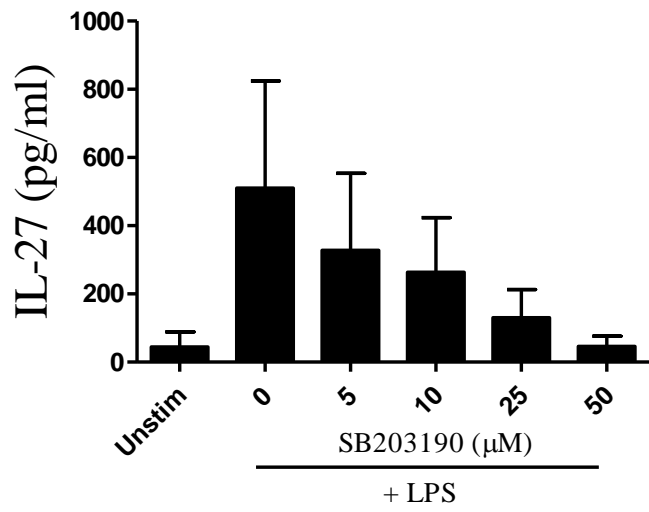
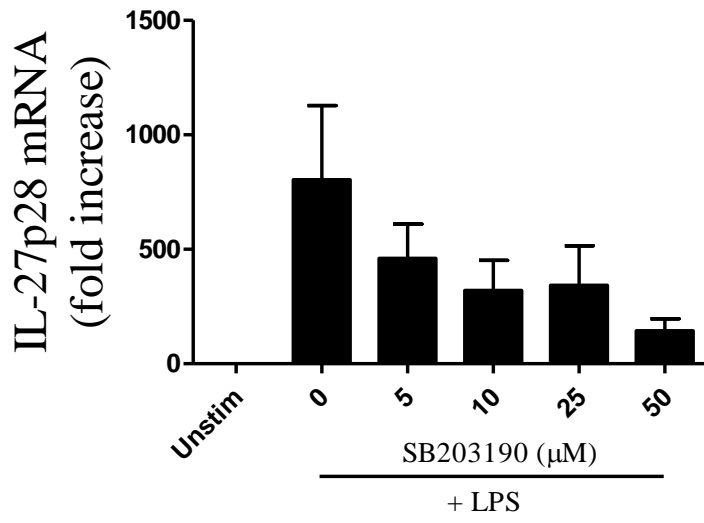

Figure 4.2.5

Fig. 4.2.6 p38 MAPK siRNA inhibits LPS-induced IL-27 expression in THP-1 cells. THP-1 cells (2.5×10^5) were transfected with the either control siRNA or p38 MAPK siRNA for 24 hours followed by stimulation with LPS ($1 \mu\text{g/ml}$) for 30 minutes for the determination of phosphorylated p38 MAPK by Western blot analysis. The result is a representative of 3 independent experiment. THP-1 cells were transfected with the either control siRNA or p38 MAPK siRNA for 24 h followed by stimulation with LPS ($1 \mu\text{g/ml}$, 24 h) for assessment of IL-27 protein production by ELISA. The results are shown as mean \pm SEM of 3 independent experiments; ** $p < 0.01$, ctrl – control siRNA.

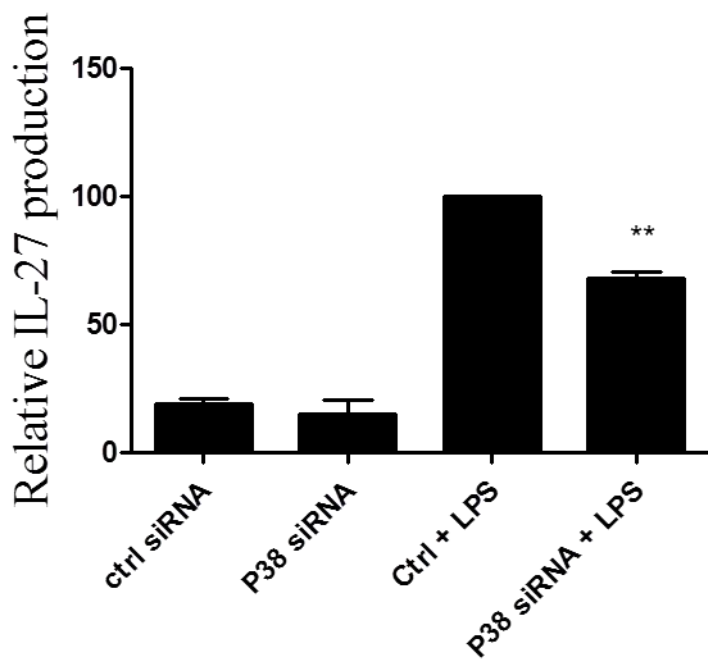
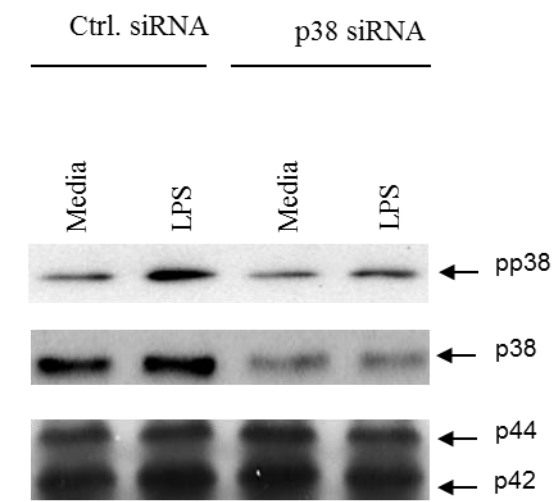

Figure 4.2.6

treated with JNK siRNA exhibited reduced phosphorylation of JNK MAPK compared to cells treated with control siRNA following LPS stimulation (Figure 4.2.4 upper panel). Likewise, cells treated with p38 siRNA showed reduced LPS-induced phosphorylation of p38 MAPK relative to control siRNA (Figure 4.2.6 upper panel). Finally, cells transfected with JNK and p38 MAPK siRNA significantly inhibited LPS-induced IL-27p28 mRNA (Figure 4.2.4 middle panel) as well as IL-27 protein production (Figure 4.2.4 and 4.2.6 middle and lower panels, respectively).

In IFN- γ /LPS and LPS-stimulated MDMs, inhibition of JNK and p38 MAPK signaling pathways led to significant decrease of IL-27 protein production levels (Figure 4.2.7 and 4.2.8). However, this decrease of IL-27 production was not observed in the expression of the distinct subunits of IL-27 (Figures 4.2.7 and 4.2.8). Inhibition of IFN- γ /LPS-activated JNK MAPK did not have an effect on the the expression of IL-27p28 mRNA (Figure 4.2.7 upper left panel). In contrast inhibition of IFN- γ /LPS-activated JNK MAPK led to a dose-dependent enhancement of IL-27 EBI3 mRNA expression, suggesting that JNK is involved in the negative regulation of IL-27 EBI3 mRNA (Figure 4.2.7 middle left panel). This differential involvement of MAPK in the regulation of IL-27 subunit expression was further observed when IFN- γ /LPS-activated p38 MAPK was inhibited. The inhibition of p38 led to enhancement of IL-27p28 mRNA, while having no effect on IL-27 EBI3 mRNA expression (Figure 4.2.8 upper, middle left panel). Collectively, these results demonstrate that JNK and p38 MAPK are involved in the regulation of distinct subunits of IL-27. JNK MAPK seems to be a negative regulator of IL-27EBI3, while p38 MAPK negatively regulates IL-27p28 subunits.

Fig. 4.2.7 IFN- γ /LPS-induced IL-27 production is positively regulated through the JNK MAPK pathway in human MDMs. MDMs were treated with increasing concentrations of JNK MAPK inhibitor, SP600125 (0-50 μ M) for 2 h followed by stimulation with IFN- γ (10 ng/ml, 16 h) and LPS (1 μ g/ml, 4 h) for quantification of IL-27p28 and EBI3 mRNA expression by RQ-PCR, whereas IL-27 protein production was determined by ELISA, IFN- γ (10 ng/ml, 16 h) and LPS (1 μ g/ml, 24 h). Panels on the left-hand side represent IFN- γ /LPS-induced IL-27 expression, while right-hand side panels represent IL-27 expression levels induced by LPS alone. The results are shown as mean \pm SEM (n=7), * p < 0.05; ** p < 0.01; *** p < 0.001, Unstim- unstimulated.

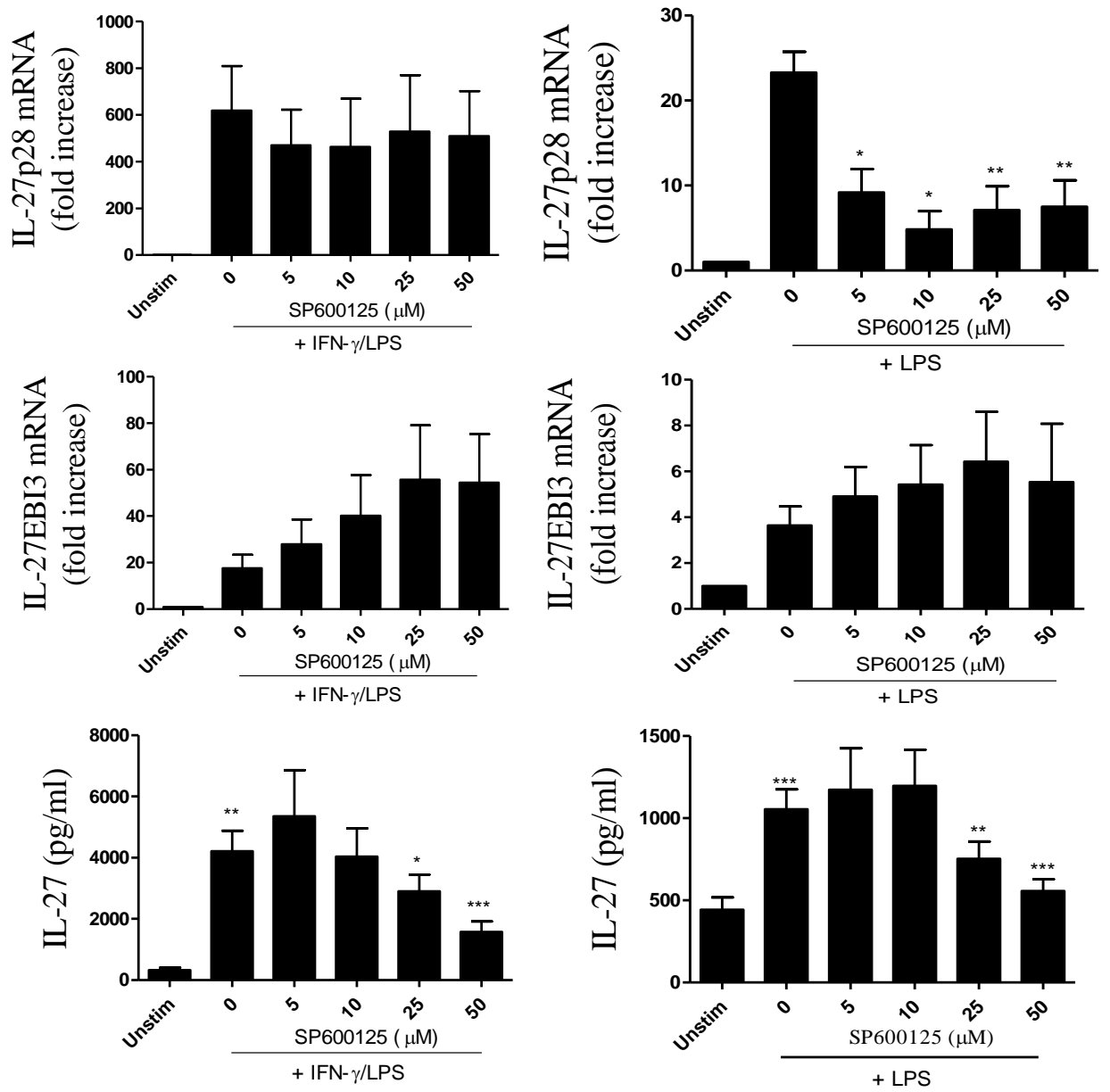

Figure 4.2.7

Fig. 4.2.8 IFN- γ /LPS-induced IL-27 production is positively regulated through the p38 MAPK pathway in human MDMs. MDMs were treated with increasing concentrations of p38 MAPK inhibitor, SB203580 (0-50 μ M) for 2 h followed by stimulation with IFN- γ (10 ng/ml, 16 h) and LPS (1 μ g/ml, 4 h) for quantification of IL-27p28 and EBI3 mRNA expression by RQ-PCR, whereas IL-27 protein production was determined by ELISA, IFN- γ (10 ng/ml, 16 h) and LPS (1 μ g/ml, 24 h). Panels on the left-hand side represent IFN- γ /LPS-induced IL-27 expression, while right-hand side panels represent IL-27 expression levels induced by LPS alone. The results are shown as mean \pm SEM of 5 independent experiments; * $p < 0.05$, Unstim- unstimulated.

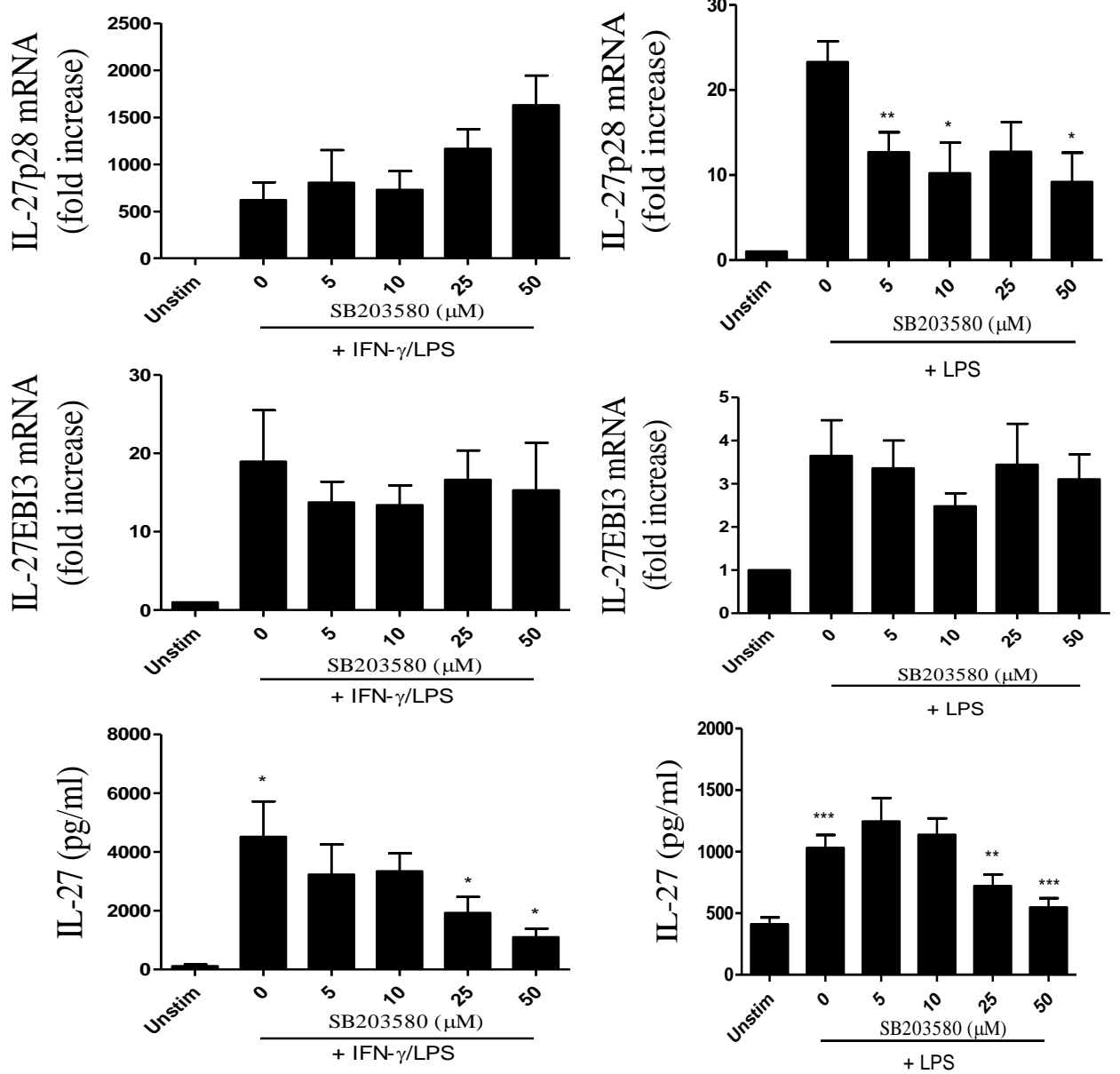

Figure 4.2.8

Inhibition of ERK MAPK by PD98059 did not affect the expression of either IL-27p28 mRNA or IL-27 protein levels in IFN- γ -primed LPS-stimulated MDMs and LPS-stimulated THP-1 cells (Figure 4.2.9 and data not shown).

Role of the PI3K signalling in IFN- γ /LPS-induced IL-27 expression

The effect of the PI3K on IFN- γ /LPS-induced IL-27 expression was also evaluated. The ability of the PI3K inhibitor, LY294002, to prevent Akt phosphorylation in LPS-treated THP-1 cells was first determined by Western blot analysis (Figure 3.2.6). As expected, Akt phosphorylation was decreased in these cells with increasing concentrations of inhibitor relative to cells stimulated with LPS alone, confirming the biological activity of the inhibitor. The effect of PI3K inhibition on IL-27 expression was then determined. THP-1 cells pre-treated with increasing concentrations of PI3K inhibitor and then were stimulated with LPS. LPS-stimulated THP-1 cells pre-treated with increasing concentrations of PI3K inhibitor exhibited decreased levels of IL-27p28 mRNA as well as IL-27 protein production (Figure 4.2.10 middle and lower panel).

To further confirm these results, I have used siRNA specific for p85, the catalytical subunit of Class IA PI3K (Figure 4.2.11 upper panel). THP-1 cells were transfected with p85PI3K specific siRNAs for 24 hr followed by stimulation with LPS for 15-30 min for the detection of p85 phosphorylation by Western blot analysis, or for 24hr for IL-27 protein production by ELISA. Results suggest that siRNA against the p85 subunit significantly inhibited LPS-induced p85 phosphorylation (Fig 4.2.11 upper panel) as well as IL-27 expression (Figure 4.2.11 lower panel). Taken together, these results suggest that PI3K

Fig. 4.2.9 IFN- γ /LPS-induced IL-27 production is not regulated through the ERK MAPK pathway in human MDMs. MDMs were treated with increasing concentrations of ERK MAPK inhibitor, PD98059 (0-50 μ M) for 2 h followed by stimulation with IFN- γ (10 ng/ml, 16 h) and LPS (1 μ g/ml, 4 h) for quantification of IL-27p28 and EBI3 mRNA expression by RQ-PCR, whereas IL-27 protein production was determined by ELISA, IFN- γ (10 ng/ml, 16 h) and LPS (1 μ g/ml, 24 h). Panels on the left-hand side represent IFN- γ /LPS-induced IL-27 expression, while right-hand side panels represent IL-27 expression levels induced by LPS alone. The results are shown as mean \pm SEM of 3 independent experiments, Unstim- unstimulated.

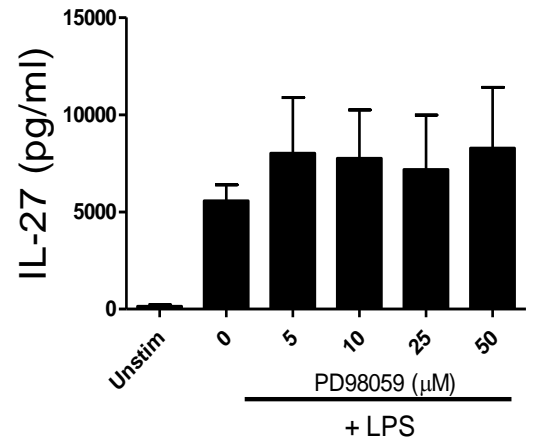
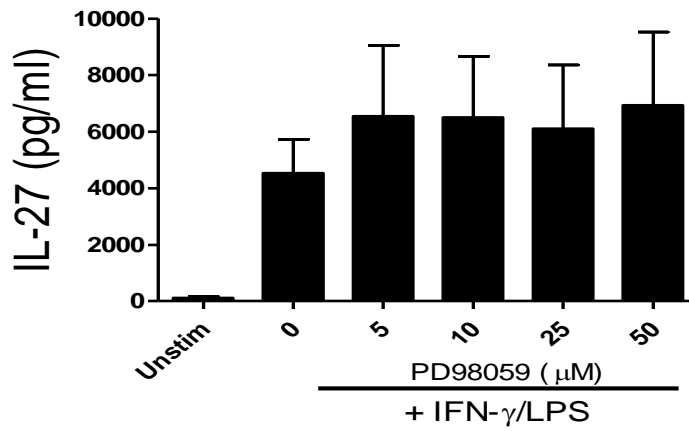
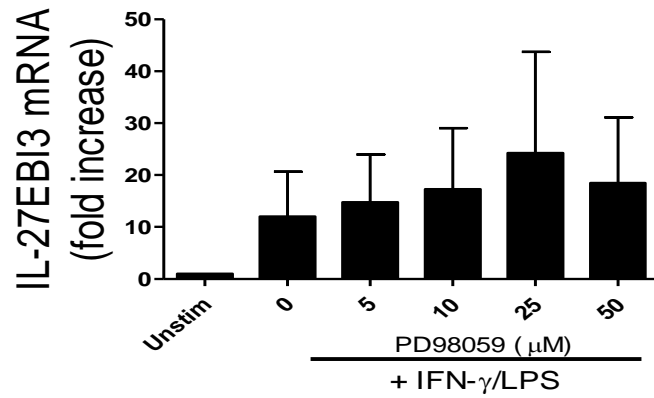
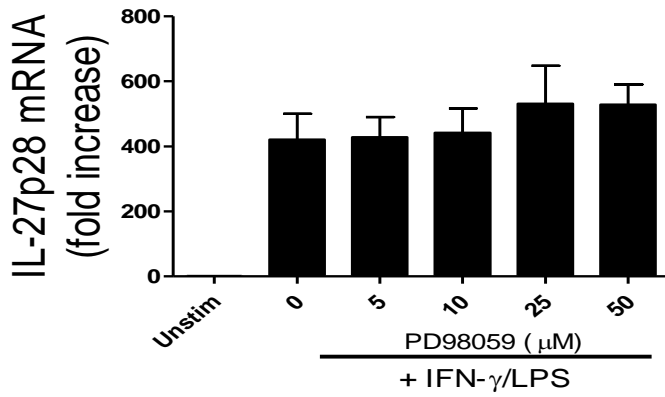

Figure 4.2.9

Fig. 4.2.10 LPS-induced IL-27 production is positively regulated through the PI3K pathway in THP-1 cells. THP-1 (1×10^6 /ml) were treated with increasing concentrations of PI3K inhibitor, LY294002 (0-50 μ M) for 2 h followed by stimulation with LPS (1 μ g/ml, 4 h) for quantification of IL-27p28 mRNA expression by RQ-PCR, whereas IL-27 protein production was determined by ELISA, LPS (1 μ g/ml, 24 h). The results are shown as mean \pm SEM of 3 independent experiments. Results were generated by Dr. Ali R. Rahimi.

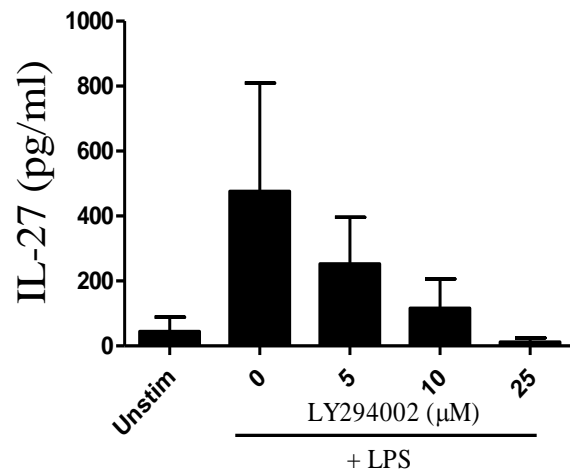
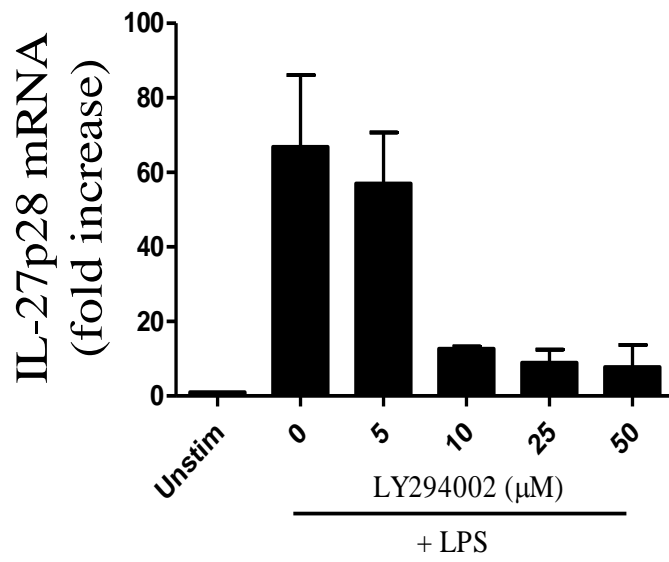

Figure 4.2.10

Fig. 4.2.11 PI3K MAPK siRNA inhibits LPS-induced IL-27 expression in THP-1 cells. THP-1 cells (2.5×10^5) were transfected with the either control siRNA or p85 siRNA for 24 hours followed by stimulation with LPS ($1 \mu\text{g/ml}$) for 30 minutes for the determination of phosphorylated p85 MAPK by Western blot analysis. The result is a representative of 3 independent experiment. THP-1 cells were transfected with the either control siRNA or p85 siRNA for 24 h followed by stimulation with LPS ($1 \mu\text{g/ml}$, 24 h) for assessment of IL-27 protein production by ELISA. The results are shown as mean \pm SEM of 4 independent experiments; * $p < 0.05$, ctrl – control siRNA.

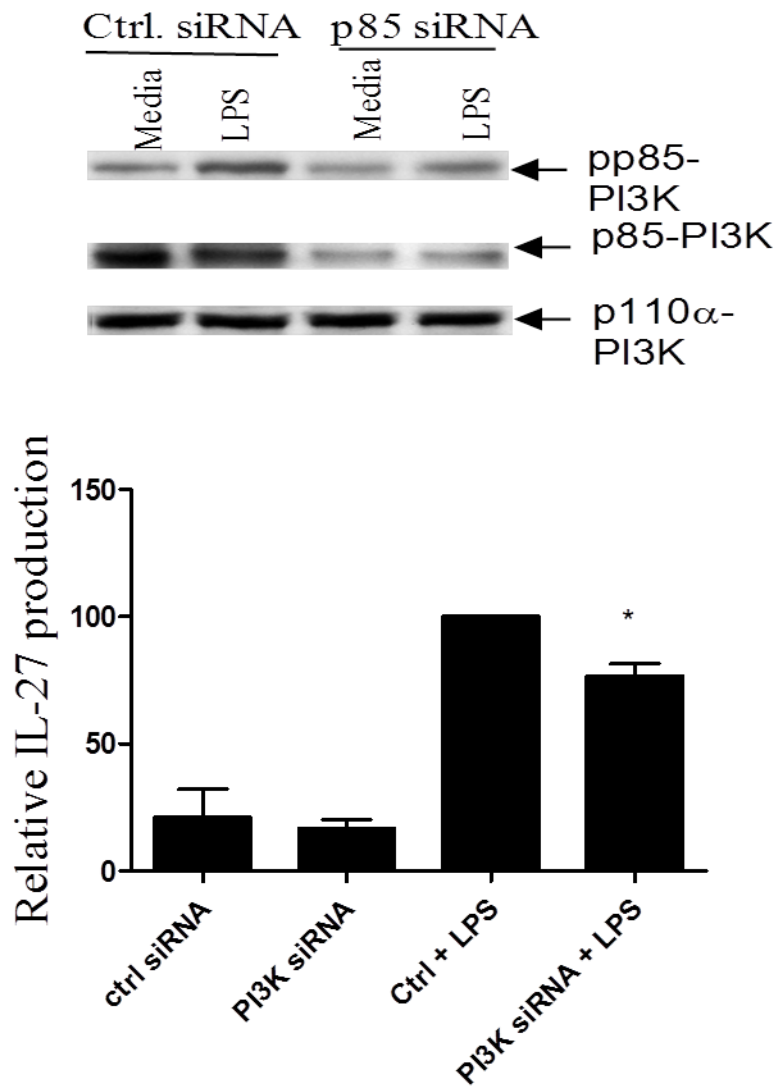

Figure 4.2.11

signalling pathway positively regulates LPS-induced IL-27 gene expression and protein production in THP-1 cells.

Similar to the results obtained with THP-1 cells, IL-27 protein production was significantly inhibited by LY294002 in MDMs (Figure 4.2.12 right lower panel). Inhibition of LPS-activated PI3K resulted in a significant dose-dependent decrease of both p28 and EBI3 mRNA, strongly suggesting that PI3K plays a critical role in the induction of IL-27 and its subunits. It was also of interest to determine whether PI3K is involved in the regulation of IL-27 in IFN- γ /LPS-stimulated MDMs. Interestingly, inhibition of IFN- γ /LPS-activated PI3K resulted in decrease in IL-27 protein production with a concomitant induction of IL-27 EBI3 mRNA expression and no effect on p28 subunit (Figure 4.2.12 left panel). Collectively, my data suggest that PI3K is a positive regulator of IFN- γ /LPS and LPS-induced IL-27 protein. However, PI3K differentially regulates IL-27p28 and EBI3 mRNA expression in IFN- γ /LPS versus LPS-stimulated human MDMs.

Role of JAK/STAT signaling pathways in IFN- γ /LPS-induced IL-27 expression

As previously mentioned, IFN- γ mediates its biological effects primarily via the activation of Jak/STAT pathway. As such, I wanted to see whether IFN- γ /LPS-induced IL-27 production in MDMs is regulated through the Jak/STAT signaling pathways. As seen in Figure 4.2.13, the inhibition of JAK kinase did not affect IFN- γ /LPS-induced IL-27p28 or EBI3 mRNA transcripts, nor IL-27 production in MDMs.

In conclusion, my data show a differential regulation of IL-27p28 mRNA and IL-27 proteins in response to stimulation of THP-1 cells by LPS or stimulation of MDMs with either LPS or IFN- γ and LPS. Moreover, my data demonstrated that IL-27 expression is

Fig. 4.2.12 IFN- γ /LPS-induced IL-27 production is positively regulated through the PI3K pathway in human MDMs. MDMs were treated with increasing concentrations of PI3K inhibitor, LY294002 (0-50 μ M) for 2 h followed by stimulation with IFN- γ (10 ng/ml, 16 h) and LPS (1 μ g/ml, 4 h) for quantification of IL-27p28 and EBI3 mRNA expression by RQ-PCR, whereas IL-27 protein production was determined by ELISA, IFN- γ (10 ng/ml, 16 h) and LPS (1 μ g/ml, 24 h). Panels on the left-hand side represent IFN- γ /LPS-induced IL-27 expression, while right-hand side panels represent IL-27 expression levels induced by LPS alone. The results are shown as mean \pm SEM of 7 independent experiments; * $p < 0.05$; ** $p < 0.01$, Unstim- unstimulated.

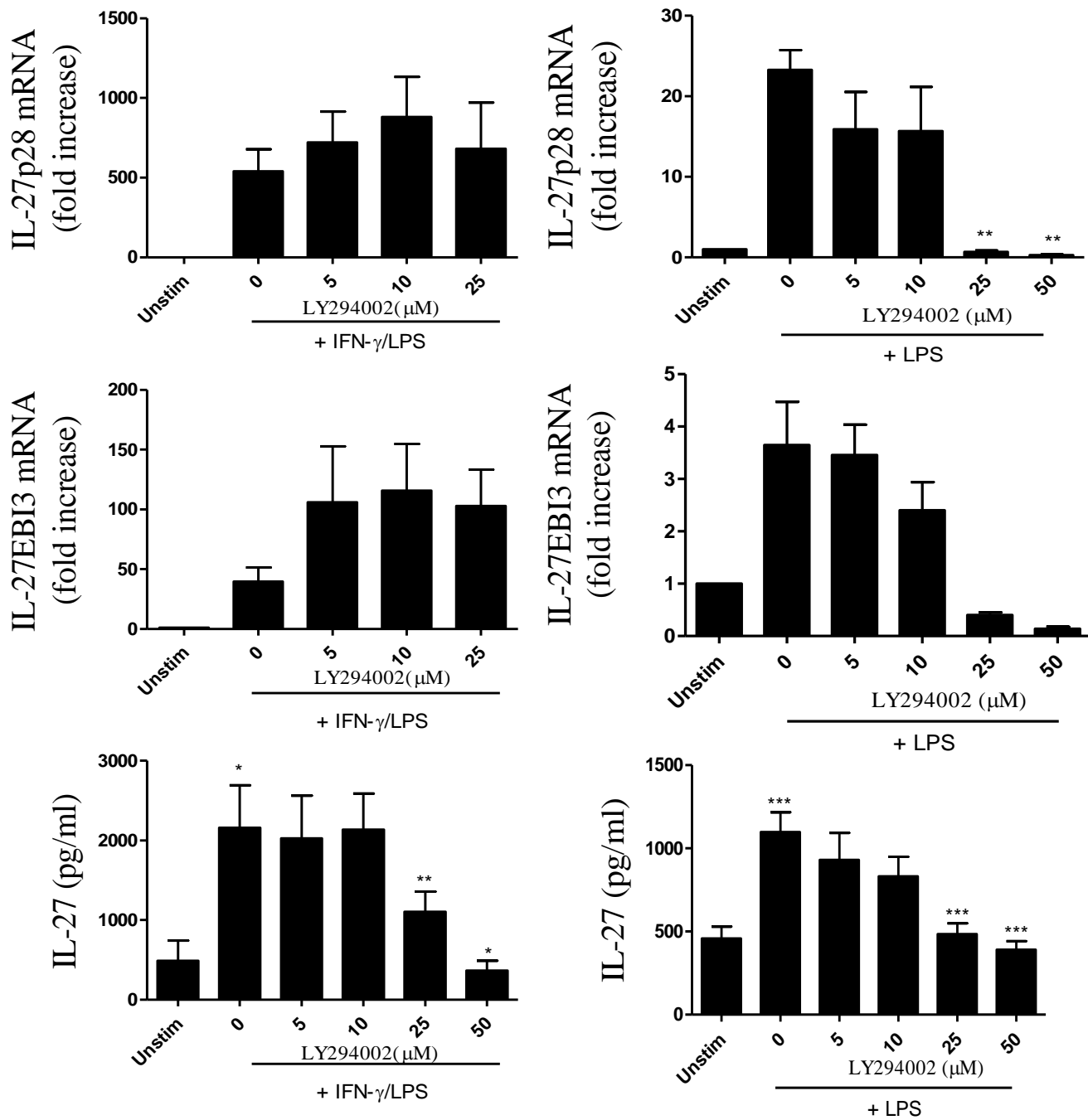

Figure 4.2.12

Fig. 4.2.13 IFN- γ /LPS-induced IL-27 production is not regulated through the JAK/STAT pathway in human MDMs. MDMs were treated with increasing concentrations of JAK inhibitor, JAK I inhibitor (0-100 nM) for 2 h followed by stimulation with IFN- γ (10 ng/ml, 16 h) and LPS (1 μ g/ml, 4 h) for quantification of IL-27p28 and EBI3 mRNA expression by RQ-PCR, whereas IL-27 protein production was determined by ELISA, IFN- γ (10 ng/ml, 16 h) and LPS (1 μ g/ml, 24 h). Panels on the left-hand side represent IFN- γ /LPS-induced IL-27 expression, while right-hand side panels represent IL-27 expression levels induced by LPS alone. The results are shown as mean \pm SEM of 3 independent experiments; * $p < 0.05$; ** $p < 0.01$, Unstim- unstimulated.

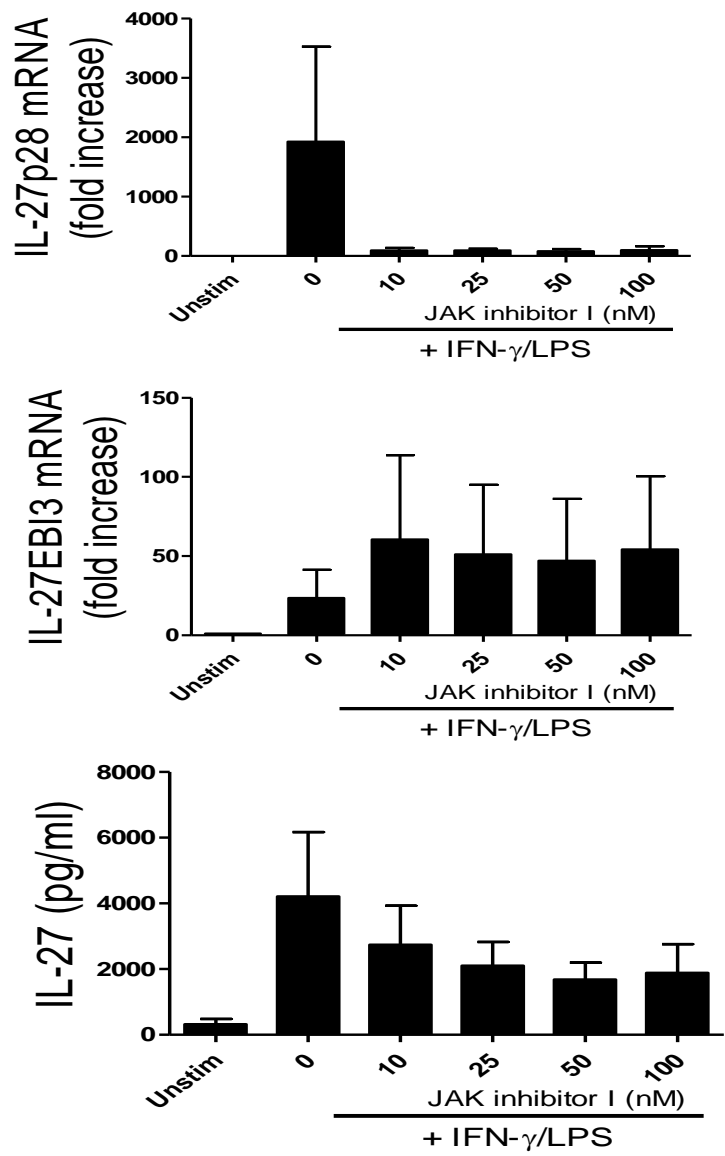

Figure 4.2.13

positively regulated by JNK, p38 MAPKs and by PI3K in response to either LPS or IFN- γ and LPS in THP-1 cells and MDMs.

Chapter 5 Inconsistency in the expression of IL-27 protein and its mRNA cognate subunits in response to IFN- γ /LPS stimulation in human MDMs

Proteosomal and lysosomal degradation

The mechanism of IFN- γ /LPS-induced IL-27 production revealed an inconsistency in the expression of IL-27 protein and its mRNA cognate subunits. My earlier results have demonstrated that IL-27 and its subunits are differentially regulated by JNK, p38 and PI3K signaling pathways in IFN- γ /LPS-stimulated MDMs (Figure 4.2.7, 4.2.8 and 4.2.12). In order to confirm that IL-27p28 and EB13 protein subunits were also differentially regulated, cell-associated IL-27p28 and EB13 levels were determined by Western blot in the presence of JNK, p38 MAPK and PI3K inhibitors, following IFN- γ /LPS-stimulation of MDMs. The results show that inhibition of JNK, p38 as well as PI3K led to a decrease at higher concentrations in the expression of EB13 proteins at higher concentration of inhibitor, in contrast to the levels of p28 subunits that remained unaffected by pre-treatment of cells with these inhibitors (Figure 5.1.1). It should be noted that under the same experimental conditions the levels of IL-27-induced secretion was decreased by inhibition of JNK, p38 and PI3K (Figure 5.1.1). This means that the activation of these three pathways is necessary for the induction of EB13 and p28 mRNA expression.

To gain insight in observed inconsistency between the IFN- γ /LPS-induced IL-27 and its subunits in MDMs the involvement of lysosomal or proteosomal degradation was examined. Chloroquine is a lysosomotropic agent that prevents endosomal acidification. It inhibits autophagy as it raises the lysosomal pH, which leads to inhibition of both fusion of autophagosome with lysosome and lysosomal protein degradation (201).

Fig. 5.1.1 IFN- γ /LPS-induced IL-27 EBI3 subunit expression is positively regulated through the JNK, p38 MAPK and PI3K pathway in human MDMs. MDMs were treated with increasing concentrations of JNK, p38 MAPK and PI3K inhibitors, for 2 h followed by stimulation with IFN- γ (10 ng/ml, 16 h) and LPS (1 μ g/ml, 24 h). Cell lysates were collected and cell-associated levels of IL-27p28 and EBI3 were determined by Western blot analysis. Total proteins (30 μ g) were analyzed by SDS-PAGE using anti-IL-27 antibodies. Membranes were stripped and re-probed with anti-GAPDH antibodies to control for protein loading. The results shown are representatives of three independent experiments. Uns – unstimulated, I – IFN- γ , L- LPS, SP – SP600125, SB – SB203580, LY – LY294002.

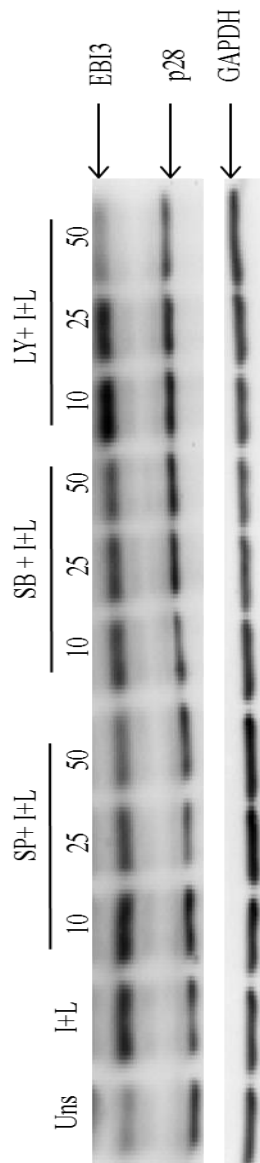

Figure 5.1.1

To determine whether lysosomal degradation plays a role in the inconsistency of IL-27 mRNA-protein levels, macrophages were first pretreated with chloroquine to inhibit lysosomal degradation, followed by inhibition of MAPK and PI3K for 2hr, and finally the cells were stimulated with IFN- γ and LPS. The cell-associated expression of EBI3 and p28 were then determined by Western Blot analysis. These results show that the presence of chloroquine did not impact the expression level of EBI3 or p28 in IFN- γ /LPS cells treated with SP, SB or LY (Figure 5.1.2 versus 5.1.1).

Keeping in view that lysosomal degradation does not affect and hence cannot account for the inconsistency of mRNA levels, I next examined that involvement of the proteasome in this phenomenon. For this I have employed clasto-lactacystin, a proteasomal degradation inhibitor. Clasto-Lactacystin β -lactone is a cell permeable, irreversible proteasome inhibitor. It inhibits protein breakdown and activities of the 20S and 26S ribosomal subunits. However, it does not inhibit lysosomal protein degradation in the cell. Macrophages were first pretreated with clasto-lactacystin to inhibit proteasomal degradation, followed by inhibition of MAPK and PI3K for 2hr, and finally the cells were stimulated with IFN- γ and LPS. These results show that the presence of clasto-lactacystin did not influence the expression level of EBI3 or p28 in IFN- γ /LPS cells treated with SP, SB or LY (Figure 5.1.3 versus 5.1.1). Collectively, these results suggest that neither lysosomal nor proteasomal degradation contributes to the inconsistency observed between IL-27 protein secretion and mRNA expression of its subunits in IFN- γ /LPS-stimulated MDMs.

Role of tristetraprolin

Next, I wanted to determine whether post-translational regulation of IL-27 subunits occurs via the modification of their mRNA stability through adenosine/uridine-rich elements

Fig. 5.1.2 Lysosomal degradation is not implicated in IFN- γ /LPS-induced IL-27 EBI3 or IL-27p28 subunit expression in human MDMs. MDMs were treated first pretreated with chloroquine (25 μ M) for 2 hr. Following this, increasing concentrations of JNK, p38 MAPK and PI3K inhibitor (0-50 μ M) were added to the cells, for 2 h followed by stimulation with IFN- γ (10 ng/ml, 16 h) and LPS (1 μ g/ml, 24 h). Cell lysates were collected and cell-associated levels of IL-27p28 and EBI3 were determined by Western blot analysis. Total proteins (30 μ g) were analyzed by SDS-PAGE using anti-IL-27 antibodies. Membranes were stripped and re-probed with anti-GAPDH antibodies to control for protein loading. The results shown are representatives of three independent experiments. Uns – unstimulated, I – IFN- γ , L- LPS, CQ – Chloroquine, SP – SP600125, SB – SB203580, LY – LY294002.

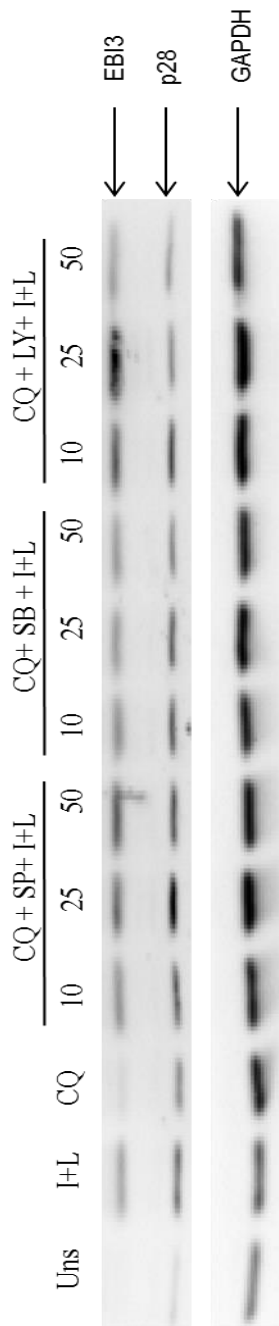

Figure 5.1.2

Fig. 5.1.3 Proteosomal degradation is not implicated in IFN- γ /LPS-induced IL-27 EBI3 or IL-27p28 subunit expression in human MDMs. MDMs were treated first pretreated with clasto-lactacystin (5 μ M) for 2 hr. Following this, increasing concentrations of JNK, p38 MAPK and PI3K inhibitor (0-50 μ M) were added to the cells, for 2 h followed by stimulation with IFN- γ (10 ng/ml, 16 h) and LPS (1 μ g/ml, 24 h). Cell lysates were collected and cell-associated levels of IL-27p28 and EBI3 were determined by Western blot analysis. Total proteins (30 μ g) were analyzed by SDS-PAGE using anti-IL-27 antibodies. Membranes were stripped and re-probed with anti-GAPDH antibodies to control for protein loading. The results shown are representatives of three independent experiments. Uns – unstimulated, I – IFN- γ , L- LPS, c-lac – clastolactacystin, SP – SP600125, SB – SB203580, LY – LY294002.

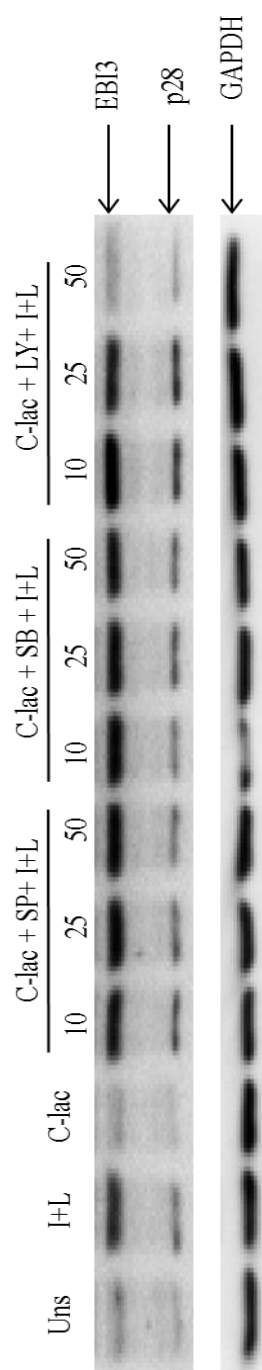

Figure 5.1.3

(AREs) in the 3'UTR region. TTP is an RNA-binding decay protein involved in the regulation of inflammatory responses at the post-transcriptional level (202). Recently, it has been shown that IFN- γ differentially regulates IL-12 and IL-23 expression in mice, via a selective suppression mechanism by TTP-mediated p19 mRNA degradation (203). A better understanding of post-transcriptional and post-translational modifications of the IL-12 family of cytokines, may clarify the observed inconsistency. For this reason, mRNA levels of TTP in MDMs stimulated with IFN- γ /LPS were observed. Results show that TTP mRNA levels increased when cells were treated with either LPS alone, or with IFN- γ and LPS (Figure 5.1.4). Next, I determined whether pretreatment of MDMs with inhibitors before stimulation with IFN- γ /LPS and SP, SB and LY had an impact on the expression level of TTP mRNA. As seen in Figure 5.1.5, in contrast to results obtained with JNK and p38 MAPK inhibitors, pre-treatment of MDMs with PI3K inhibitor before IFN- γ /LPS stimulation increased TTP mRNA expression. These results suggest that accumulation of TTP mRNA levels in MDMs treated with LY may lead to a destabilization of IL-27p28 mRNA levels, accounting for the low levels of IL-27 protein levels in the supernatants.

Role of IL-27 receptor recycling

In parallel, I have also addressed a role of IL-27 receptor recycling in the mechanism of inconsistency between the mRNA IL-27 subunits expression and protein secretion. The IL-27 receptor consists of the orphan cytokine receptor WSX-1/TCCR and gp130. Gp130 is part of the IL-6 receptor family and is shared among other cytokine receptors (204). WSX-1 is structurally similar to gp130, and was first identified through a homology search of gp130 cDNA (60). IL-27R is expressed on myeloid and

Fig. 5.1.4 IFN- γ /LPS and LPS alone treatment increased TTP mRNA expression in human MDMs. MDMs were treated with IFN- γ (10 ng/ml, 16 h) and/or LPS (1 μ g/ml, 4 h) for quantification of tristetraprolin (TTP) mRNA expression by RQ-PCR. The results are shown as mean \pm SEM of 5 independent experiments; * $p < 0.05$; *** $p < 0.001$, Unstim- unstimulated.

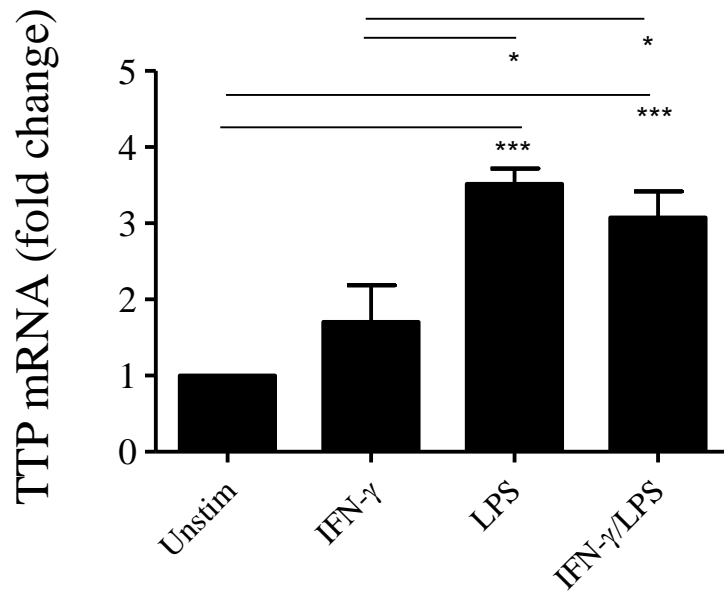

Figure 5.1.4

Fig. 5.1.5 IFN- γ /LPS-induced TTP mRNA expression is negatively regulated through the PI3K pathway in human MDMs. MDMs were treated with increasing concentrations of JNK, p38 MAPK and PI3K inhibitors, (0-50 μ M) for 2 h followed by stimulation with IFN- γ (10 ng/ml, 16 h) and LPS (1 μ g/ml, 4 h) for quantification of TTP mRNA expression by RQ-PCR. The results are shown as mean \pm SEM of 5 independent experiments; * $p < 0.05$; ** $p < 0.01$, Unstim-unstimulated.

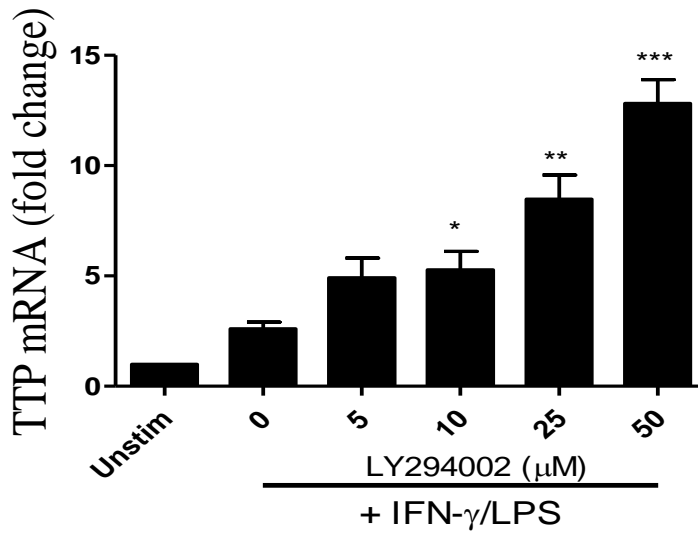
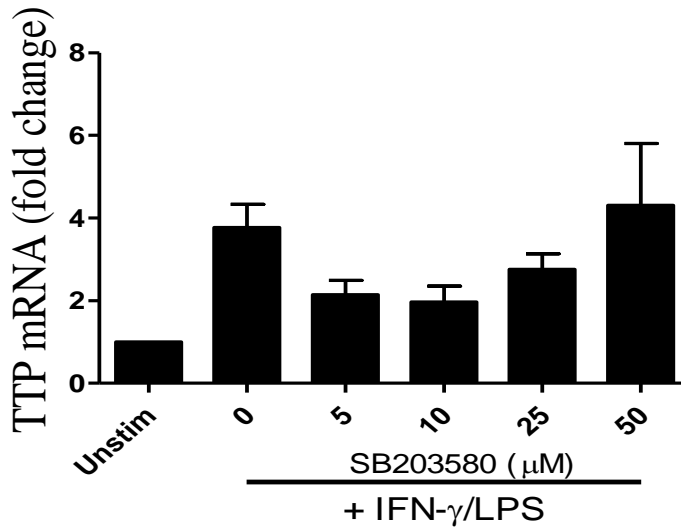
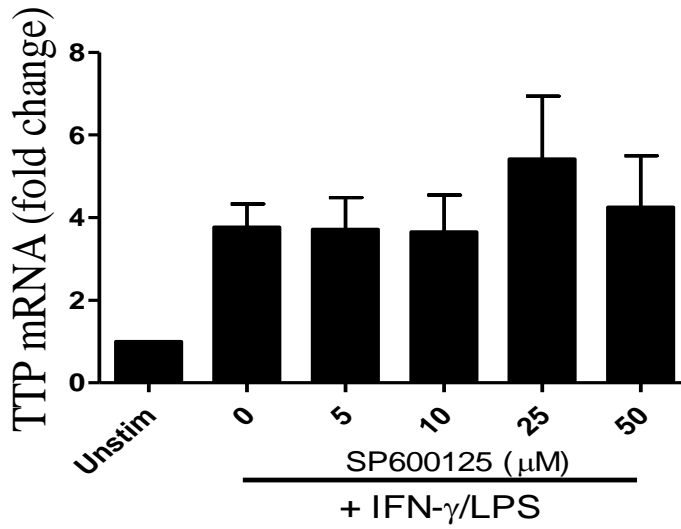

Figure 5.1.5

lymphoid lineages of hemopoietic cells, stem cells, keratinocytes and vascular endothelium.

The cell-surface expression of IL-27 receptors, WSX-1 and gp130, in MDMs stimulated with IFN- γ /LPS was measured (Figure 5.1.6) by flow cytometry. Results show that LPS alone or IFN- γ /LPS stimulation led to a significant upregulation of cell-surface expression of both WSX-1 and gp130 in MDMs. To understand whether the inhibition of MAPK and PI3K signalling pathways involved in the regulation of IL-27 expression play a role in this increase of cell-surface expression of IL-27 receptor chains (Figure 5.1.7), I have treated the cells with the respective inhibitors. The results show that both WSX-1 and gp130 are negatively regulated by JNK MAPK, while p38 MAPK and PI3K positively regulate the expression of these receptors in IFN- γ /LPS-stimulated MDMs. The highly upregulated expression of WSX-1 and gp130 upon JNK MAPK inhibition may suggest a process of increased up-take of IL-27 back into the macrophages, leading to the depletion of IL-27 protein expression in the supernatant. Upregulated expression of IL-27 receptor chains may interact with extracellular IL-27, causing its depletion from the supernatant. Such a mechanism may in turn account for low levels of secreted IL-27, thus accounting for the mRNA-protein inconsistency.

In summary, although these three different approaches provided an attempt to understand the mechanism of inconsistency between mRNA and protein expression, obviously there is much work to be done and further studies are required to fully understand this phenomenon.

Fig. 5.1.6 IFN- γ /LPS and LPS alone treatment increased cell-surface expression of WSX-1 and gp130 human MDMs. Cells were washed and stained with PE-conjugated mouse monoclonal anti-human WSX-1 and Per-CP-conjugated mouse monoclonal anti-human gp130 for 15 minutes. Surface expression of WSX-1 and gp130 was assessed by flow cytometry. The results are shown as mean \pm SEM (n=4), Unstim- unstimulated.

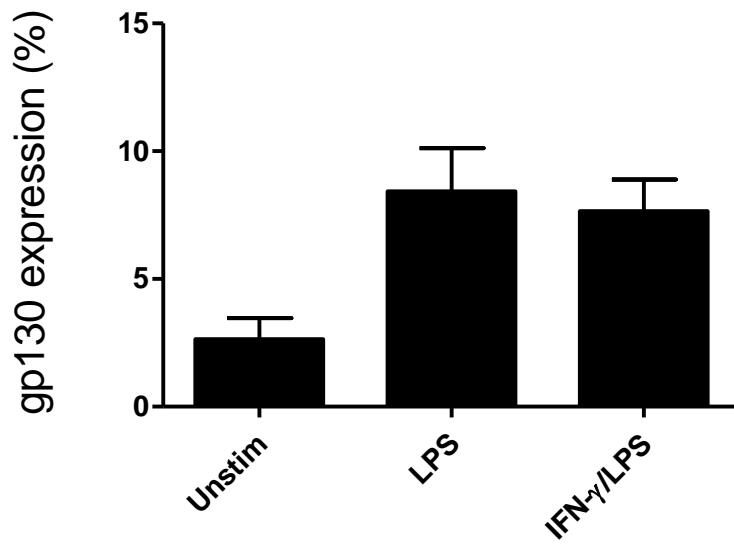
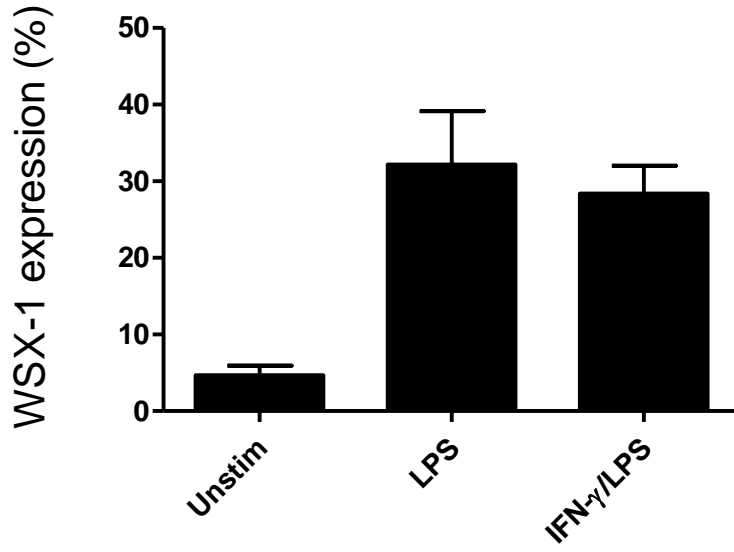

Figure 5.1.6

Fig. 5.1.7 IFN- γ /LPS and LPS alone treatment increased cell-surface expression of WSX-1 and gp130 human MDMs. MDMs were treated with increasing concentrations of JNK, p38 MAPK and PI3K inhibitors, (0-50 μ M) for 2 h followed by stimulation with IFN- γ (10 ng/ml, 16 h) and LPS (1 μ g/ml, 24 h). Surface expression of WSX-1 and gp130 was assessed by flow cytometry. The results are shown as mean \pm SEM (n=4), * p < 0.05; ** p < 0.01; *** p < 0.001; Unstim- unstimulated.

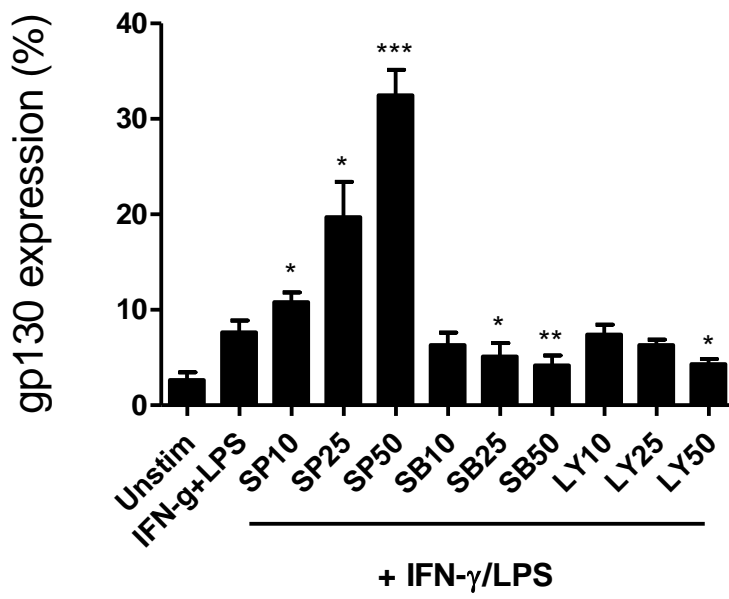
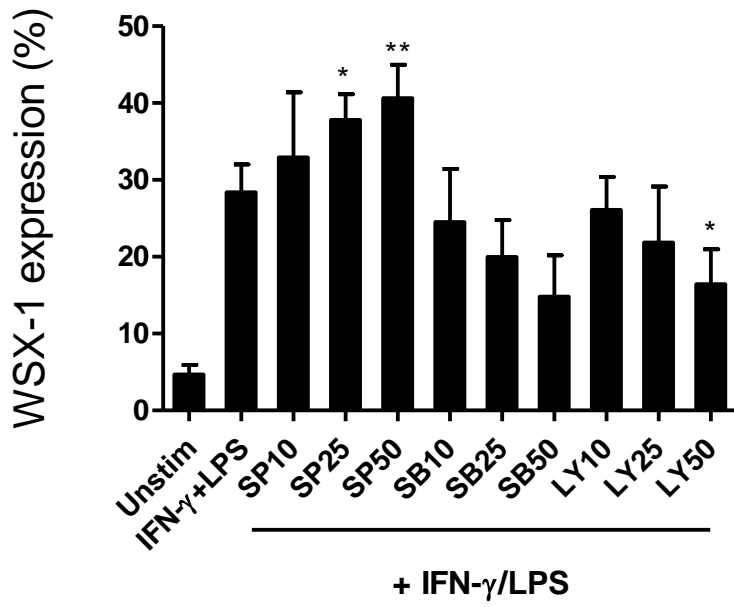

Figure 5.1.7

Chapter 6 Discussion

The main objective of my studies was to elucidate the signaling pathways involved in IFN- γ /LPS-induced production of IL-12, IL-23 and IL-27 in human monocytic cells. Therefore, with a view to shed further light into the mechanisms responsible for IL-12, IL-23 and IL-27 cytokine production, my results show that IFN- γ is able to induce IL-23 production in positively selected human monocytes, while LPS was a poor inducer. On the other hand, IFN- γ induced IL-27 production in both positively as well as negatively selected monocytes. I have also shown that THP-1 promonocytic cells and human monocyte-derived macrophages (MDMs) respond to LPS following priming with IFN- γ in order to produce significant levels of IL-23 and IL-27.

Previous studies have shown that IL-12p40 production in human monocytes is regulated through the MAPK and PI3K signaling pathways (205). Based on these observations, I proceeded to investigate the potential role of these pathways in the regulation of IFN- γ - and/or LPS-induced production of IL-23 and IL-27. My results show that distinct signalling pathways are required for the regulation on IL-23 in different cell types, such as primary monocytes, THP-1 and MDMs in response to stimulation with either IFN- γ and /or LPS. However, with regards to IL-27 regulation, I observed that its production is regulated predominately by JNK MAPK and PI3K pathways, regardless of cell type and stimulation involved. I have also shown that the IL-23 and IL-27 subunits, namely IL-23p19, IL-12/23p40, IL-27p28 and EBI3 are differentially regulated by these pathways. Furthermore, in certain cases the inhibition of signaling pathways showed increased levels of mRNA, while total protein secretion levels would decrease. Based on my observations, lysosomal or proteosomal degradation pathways could not account for this differential mRNA/protein

regulation of IL-27 subunits. However, mRNA stability following post-transcriptional modifications and cell-surface receptor recycling may play a role in the inconsistency between mRNA expression and protein secretion levels. I shall discuss in depth the regulation of IL-23 and IL-27 in different cell types in the following two chapters. Finally, I will discuss the possible mechanisms responsible for the mRNA-protein inconsistency.

Regulation of IL-23 production in human monocytic cells

Regulation of IFN- γ -induced IL-23 production in human monocytic cells: My results show that IFN- γ induces the expression of IL-12p40 and IL-23 in primary human monocytes following activation through the CD14 receptor. To understand the mechanism governing IFN- γ -mediated IL-12/23 production, I demonstrated that IFN- γ -induced IL-23 and IL-12/23p40 expression in monocytes is positively regulated by the p38 MAPK. Furthermore, IL-12 and IL-23 expression is modulated by negative signals delivered by the Jak/STAT, JNK MAPKs and PI3K pathways in IFN- γ -stimulated primary monocytes isolated by positive selection.

IFN- γ priming of monocytes and APCs enhances their ability to produce IL-12 and IL-23 in response to a second stimulus such as LPS (143). IFN- γ priming thus provides a vital positive feedback mechanism for an enhanced immune response against invading pathogens (83, 111, 206). Additionally, TLR-2, TLR-4 and TLR7/8 ligands have been shown to induce IL-23 production independently of IL-12 in DCs (111). Whether IFN- γ alone can enhance IL-12 or IL-23 expression by monocytic cells was not known. I demonstrated that IFN- γ failed to induce either IL-12p40 or IL-23 production in negatively selected monocytes

(Fig 3.1.2), THP-1 cells and MDMs (Fig 3.2.1 and 3.3.2, respectively). However, activation of primary monocytes by anti-CD14 antibodies conferred responsiveness to IFN- γ resulting in significant production of IL-12p40 and IL-23 possibly through signals delivered via interactions with CD14/TLR-4 complex. Previously, it was demonstrated that natural and recombinant soluble CD14 may stimulate monocytes *in vitro* (207). Furthermore, positive selection of monocytes has been shown to influence cytokine production in generated DCs (208). I propose that outside of an LPS context, activation of monocytic cells through the CD14 receptor during positive selection significantly impacts cytokine expression and subsequent function of these cells in response to IFN- γ stimulation. These observations also suggest that monocytic cells similarly activated *in vivo* under certain pathological conditions may produce IL-12 and IL-23 in response to IFN- γ . My results are supported by a study wherein generation of DCs from monocytes isolated by positive selection inhibited LPS-induced expression of co-stimulatory molecules and cytokines compared to the DCs generated from monocytes isolated by negative selection (208).

Furthermore, I have investigated the possible mechanism by which positively selected monocytes respond to IFN- γ leading to IL-23 production. Positive selection of monocytes through the use of anti-CD14 beads or stimulation of negatively isolated monocytes with anti-CD14 beads exhibited significantly higher levels of IFN- γ receptors. Enhanced IFNGR1 expression on positively selected monocytes may be due to signals delivered following interaction of CD14 expressed on monocytes with the anti-CD14 antibodies conjugated beads (207). Enhanced IFNGR1 expression may also explain the ability of positively selected cells to respond to IFN- γ leading to higher TLR-4 expression and subsequent enhanced production of IL-23 following LPS stimulation.

Others have previously identified signalling pathways involved in LPS-mediated IL-12/23p40 expression (11, 46, 105, 107, 108, 110, 144). I investigated the signaling pathways regulating IFN- γ -induced IL-23 and IL-12/23p40 expression in human monocytes isolated by positive selection. IFN- γ mediates its biological effects by activating the Jak/STAT pathway (140) and by STAT-1-independent pathways (86, 140, 209). My results suggest that IFN- γ -induced IL-23p19 mRNA and IL-12/23p40 and IL-23 protein expression is negatively regulated by the Jak/STAT, PI3K and JNK MAPK pathways. The mechanism by which IFN- γ -activated Jak/STAT-1, PI3K and JNK negatively regulate IL-23 or its subunits expression is not clear. However, it appears that IFN- γ -mediated signalling cascades including Jak/STAT may cross talk with the signals delivered following the engagement of CD14 receptors that may result in the induction of IL-12p40 and IL-23 expression. IFN- γ is known to induce the expression of suppressor of cytokine signalling (SOCS) proteins. SOCS1 is a negative regulator of Jak/STAT signalling and is believed to be an inhibitor of IFN- γ -induced IL-12 production in DCs (210). It is possible that the SOCS proteins induced by blocking the Jak/STAT pathway following IFN- γ stimulation may negatively regulate IL-23 production in monocytic cells. Although I have used low doses of kinase inhibitors and the increase in IL-23/IL-12 production is dose dependent, interference with ATP binding sites of other kinases cannot be ruled out.

There is some evidence that MAPKs regulate the expression of IL-12/23 subunits (IL-23p19) (110, 138, 211). Importantly, my results show that IFN- γ -induced IL-23 and IL-12/23p40 production is positively regulated by the p38 MAPK and negatively regulated by the PI3K and the JNK pathways. The mechanism by which IFN- γ activates PI3K or MAPKs is not clear (101, 103, 105). However, IFN receptors have been shown to interact directly

with the p85 subunit of PI3K (97, 98) independently of JAK-mediated phosphorylation of the receptor (98). IFN- γ has been shown to recruit myeloid differentiation primary response gene 88 (MyD88) leading to p38 MAPK activation (212). Whether IFN- γ activates MAPK and PI3K pathways in positively selected human monocytes via MyD88 recruitment is not clear. Furthermore, the mechanism by which PI3K and JNK MAPKs negatively regulate IL-23 expression needs to be investigated.

The transcription factors NF- κ B, SMAD3 and ATF-2 have been implicated in the regulation of LPS-induced IL-23p19 gene expression (18). However, the involvement of specific transcription factors in IFN- γ -induced IL-23 expression remains unknown. IFN- γ activates several transcription factors in various cell types including interferon regulatory factor (IRF)-1, IRF-8, PU.1, C/EBP, CIITA, IRF-9 and c-Jun in a STAT-1-dependent manner (213-215). IFN- γ has also been shown to activate STAT3, STAT5, NF- κ B and AP-1 in a STAT-1-independent manner (96, 216, 217). A comprehensive examination of the downstream transcription factors involved in IFN- γ -induced IL-23p19/p40 expression will provide further insight into the regulation of this cytokine. In the present study, it was not possible to delineate the involvement of IFN- γ -activated transcription factors required for IL-23 production as THP-1 cells did not produce IL-23 in response to IFN- γ . Moreover, it is extremely difficult to perform promoter analysis experiments in primary monocytes.

My results suggest that IL-23p19 and IL-12/23p40 mRNA levels did not always correlate with IL-23 protein production specifically as seen in the p38 MAPK inhibition studies. It has been reported that IL-23p19 mRNA levels are not associated with an increase in IL-23 production in response to LPS in other model systems (110, 112). Inhibition of specific signalling pathways resulting in an increased expression of IL-23 has been reported

(110, 112, 138). These observations suggest that post-transcriptional or post-translational mechanisms may regulate IL-23 expression and/or secretion (24). Several possible post-transcriptional and post-translational steps such as IL-23 subunit mRNA stability, protein translation, intracellular protein degradation and secretion of newly synthesized protein may be regulated by distinct signalling pathways. Interestingly, the p38 MAPK pathway has been shown to be an important post-transcriptional regulator of mRNA stability (218, 219). It is possible that the decrease in IL-23 protein production, despite an increase in IL-23p19 mRNA that we observed following inhibition of the p38 MAPK may be attributed to post-transcriptional or post-translational activity. My findings were summarized in Figure 5 of the Discussion section.

In summary, I show for the first time that IL-23 and its subunit IL-12/23 p40 are regulated by IFN- γ in primary human monocytes via p38 MAPK and independently of the Jak-STAT and PI3K pathways. I also show that the Jak/STAT, PI3K and JNK MAPK pathways are negative regulators of IL-23 and IL-12/23 p40 expression induced by IFN- γ . A schematic model depicting the signalling pathways involved in IFN- γ -induced expression of IL-23 in human monocytic cells is shown in Figure 5. Elucidating the mechanism of IFN- γ -induced regulation of IL-12 family cytokine expression, and particularly of IL-23, will further our understanding of immune responses in health and disease.

Figure 5 A model showing the signalling pathways involved in IL-23 induction following IFN- γ stimulation in human monocytic cells. Anti-CD14 magnetic beads increase expression of IFN- γ receptor 1, sensitizing positively selected monocytes to IFN- γ stimulation. IFN- γ stimulation initiates the oligomerization of its receptor subunit, IFNGR1 and IFNGR2, facilitating JAK activation and recruiting STAT to the receptor. Phosphorylated STAT is translocated to the nucleus. The IFN receptors have been shown to interact directly with the p85 subunit of PI3K, independently of JAK-mediated phosphorylation of the receptor (97, 98). IFNGR1 has also been shown to interact directly with MyD88 (99), which may trigger activation of the MKK6/p38 MAPK pathway (99), possibly through Pyk-2 activation (100). Furthermore, IFN- γ has also been shown to activate JNK MAPK in macrophages (101), although the precise sequence of events leading to JNK MAPK activation is not known. My results suggest that JAK/STAT, PI3K and JNK MAPK negatively regulate IL-23 induction, whereas p38 MAPK positively regulates IL-23 induction in response to IFN- γ stimulation through the activation of a yet-identified transcription factor (TF). \uparrow indicates enhanced expression whereas \downarrow indicates decreased expression following the blockage of a pathway.

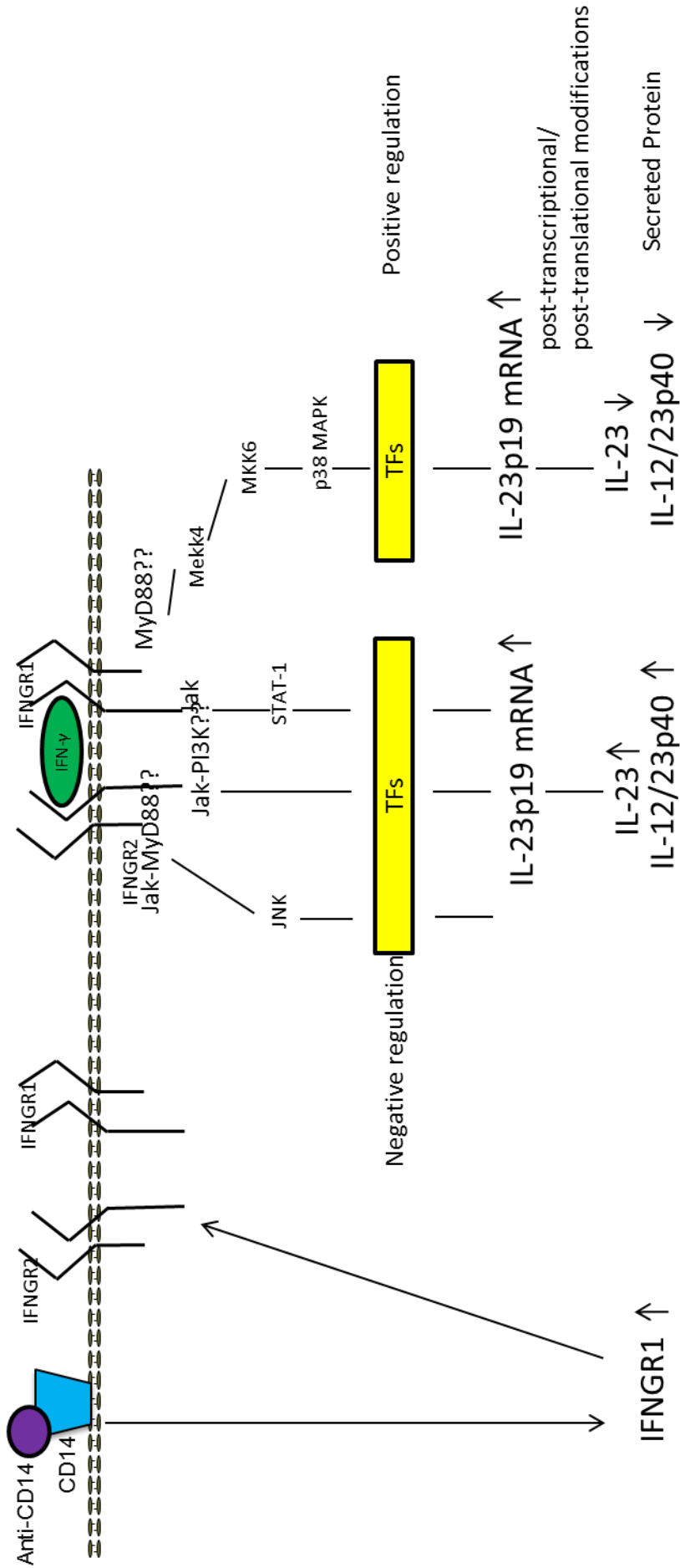

Figure 5

Regulation of LPS-induced IL-23 production in human monocytes, THP-1 cells and

MDMs: IL-23 has been shown to be involved in modulating responses to a number of infectious agents as well as regulating auto-immunity and cancer (220-222). However to date, the regulation of IL-23 expression in monocytes and other monocytic cell types in response to TLR agonists, especially TLR-4, has not yet been fully characterized.

JNKs are stress-activated protein kinases that can phosphorylate the DNA-binding protein c-Jun and increase its transcriptional activity. JNK protein kinases are encoded by three genes: JNK1, JNK2 and JNK3, however only JNK1/2 are ubiquitously expressed, while JNK3 is expressed only in the brain, heart and testis (127). SP600125 is a reversible ATP-competitive inhibitor that dose dependently inhibits the phosphorylation of c-Jun, the expression of inflammatory genes and activation of human CD4⁺ cell cultures. SP600125 may also partially inhibit p38 MAPK (132). There are four p38 kinase isoforms: α (SAPK2), β , β_2 , γ (SAPK3) and δ , with expression of these isoforms varying among tissues. p38 α being the best characterized one and expressed in most cell types, including leukocytes and bone marrow (127). p38 MAPK is involved in regulating the expression of many cytokines, having a crucial role in the activation of the immune system. SB203580, 4-(4-fluorophenyl)-2-(4-methylsulfinylphenyl)-5-(4-pyridyl)1 H-imidazole) is a specific inhibitor of p38 α and p38 β , but not other p38 MAPKs (45)(223)(224). It suppresses the activation of MAP kinase-activated protein kinase 2.

I demonstrated that LPS alone significantly induces the expression of IL-23p19 mRNA and IL-23 protein production in the human monocytic THP-1 cell line (Fig 3.2.1). These data appear consistent with other studies showing that LPS can induce IL-23 expression in human monocytes (112) and PBMCs (195). Recently, Roses *et al.* also showed that IL-23 production in human monocyte-derived DCs is stimulated by LPS (111).

Furthermore, IFN- γ alone did not induce the production of IL-23 mRNA or protein production in THP-1 cells, nor does it prime these cells for LPS-induced IL-23 secretion. Therefore, I investigated the mechanism of LPS-induced IL-23 production in THP-1 cells and evaluated the signalling pathways that may be regulating IL-23 expression. The role of MAPKs was established by using specific pharmacological inhibitors. Results show that LPS-induced IL-23 protein production is positively regulated by the JNK and p38 MAPK pathways in THP-1 cells (Figure 3.2.3). The results obtained with specific MAPK and PI3K inhibitors were confirmed using siRNA studies, which further establishes the role of these pathways to regulate LPS-induced IL-23 expression in myeloid-type cells. These data also appear consistent with a recent study showing that in murine macrophages LPS-induced IL-23p19 mRNA and IL-23 protein expression are regulated by the ERK, JNK and p38 MAPK pathways (142). Interestingly, my data show that ERK, JNK and p38 MAPK inhibition appears to negatively regulate IL-23p19 mRNA expression (Figure 3.2.3 left panels), while at the same time JNK and p38 MAPK inhibition positively regulate IL-23 production (Figure 3.2.3 middle panels). Furthermore, results suggest that IL-23p19 levels did not always correlate with IL-23 protein production. It has been reported that IL-23p19 mRNA levels are not associated with an increase in IL-23 production in response to LPS in other model systems (110, 112). Inhibition of specific signalling pathways resulting in an increased expression of IL-23 has been reported (110, 112, 138). These observations suggest that post-transcriptional or post-translational mechanisms may regulate IL-23 expression and/or secretion (24). Several possible post-transcriptional and post-translational steps such as IL-23 subunit mRNA stability, protein translation, intracellular protein degradation and secretion of newly synthesized protein may be regulated by distinct signalling pathways. Interestingly,

the p38 MAPK pathway has been shown to be an important post-transcriptional regulator of mRNA stability (218, 219). It is possible that the decrease in IL-23 protein production, despite an increase in IL-23p19 mRNA that I observed following inhibition of the p38 MAPK may be attributed to post-transcriptional or post-translational activity.

I also show that PI3K inhibition does not affect LPS-induced IL-23p19 mRNA expression, but positively regulates IL-23 as well as IL-12/23p40 protein production (Figure 3.2.6). While the number of studies examining IL-23 expression in human monocytic cells have been limited, my data are consistent with one report showing that IL-23 production is regulated by PI3K in human monocytes stimulated with *F. Novicida*, without affecting IL-23p19 mRNA levels (140). As was the case with my results on the role of MAPKs in IL-23 regulation, it seems that there may be post-transcriptional mechanisms regulating IL-23 expression and/or secretion. I show that the PI3K and MAPK pathways are positive regulators of IL-23 and that under certain conditions an increase in IL-23 mRNA expression is often associated with a decrease in secretion of IL-23 protein when specific intracellular signalling pathways are inhibited. My findings are summarized in Figure 6.

Since different signaling pathways are involved in IFN- γ and LPS-induced regulation of IL-23 and its subunits, I decided to investigate the signaling mechanisms following IFN- γ /LPS and LPS stimulation in MDMs. Even though, IFN- γ /LPS was able to induce significant levels of IL-27 expression, to my surprise, using all kinds of pharmacological inhibitors neither MAPK nor PI3K signaling pathways were found to regulate IL-23 production. My results clearly show that MAPK and PI3K signaling pathways are not involved in the regulation of LPS-induced, nor IFN- γ /LPS-induced IL-23 production in

Figure 6 A model showing the signalling pathways involved in IL-23 induction following LPS stimulation in THP-1 monocytic cells. LPS is an outer wall component of Gram-negative bacteria that induces the production of many proinflammatory mediators in monocytes/macrophages (121). It activates the CD14-TLR4-MD2 complex, which in turn activates the PI3K pathway (121), permitting docking of PI3K to the plasma membrane. Upon TLR4 activation, MyD88 is recruited to the TLR4 receptor and interacts with IL-1R-associated kinase (IRAK)-4 (125). IRAK4 will in turn activate other members of the IRAK family, resulting in the recruitment of TRAF6. This will activate a complex containing TGF- β -activated kinase (TAK1) and TAK1-binding proteins (TAB) (126). The TAK1/TAB complex triggers the MAPK and NF- κ B signaling pathways, including JNK and p38 MAPK (225). Studies have shown that LPS-TLR4 signaling in human monocytes also activates Akt (121). Akt may directly or indirectly activate MAPKs (121). My results suggest that PI3K, JNK and p38 MAPK positively regulate IL-23 induction in response to LPS stimulation through the activation of a yet-identified transcription factor (TF). \uparrow indicates enhanced expression whereas \downarrow indicates decreased expression following the blockage of a pathway.

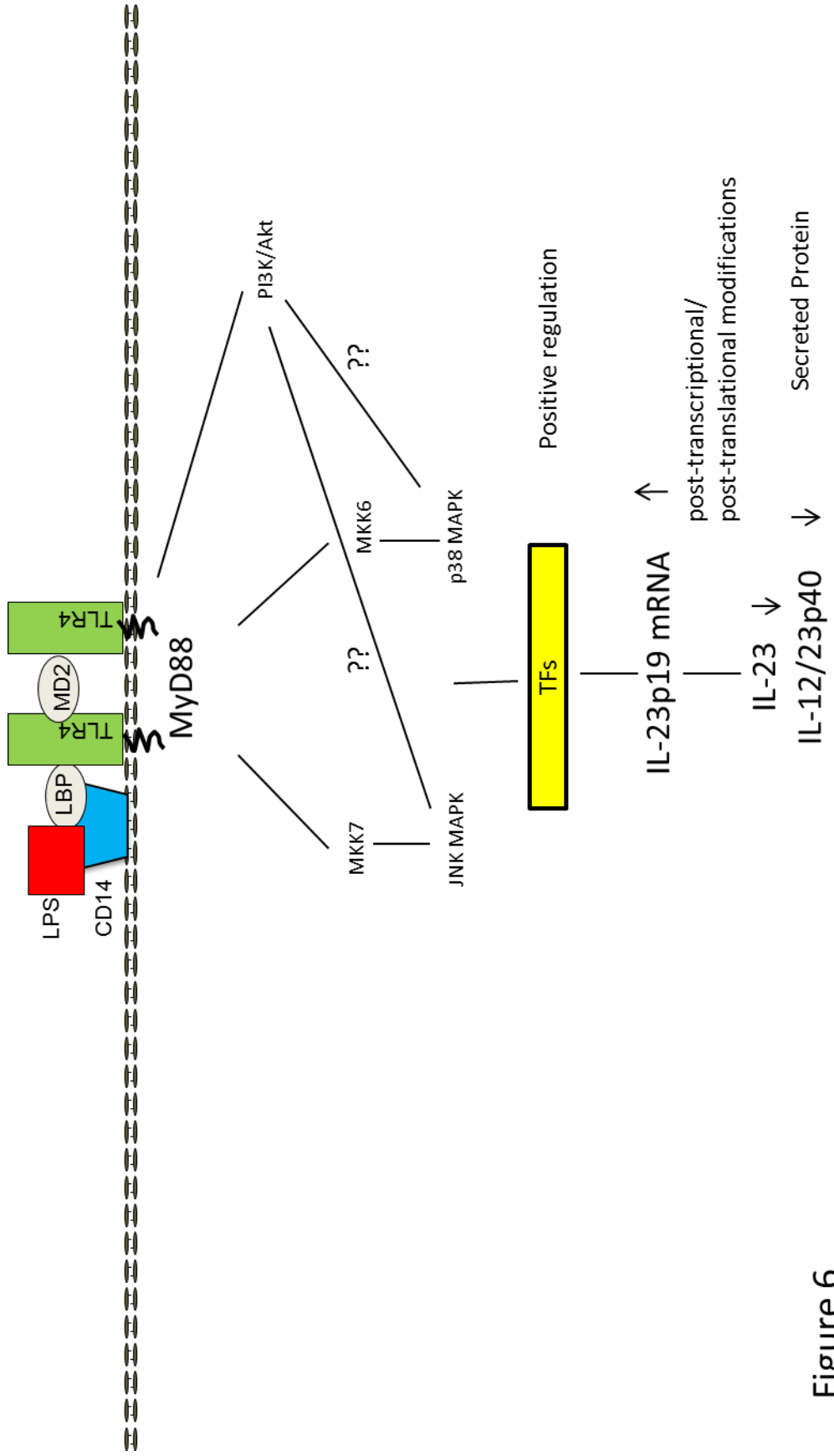

Figure 6

MDMs. I also show that the Jak/STAT pathway is not involved in the regulation of IL-23 production in IFN- γ /LPS-stimulated MDMs. Therefore, the exact mechanisms responsible for this regulation are not clear. Our laboratory has initiated more in-depth studies that show that LPS-induced IL-23 production may be positively regulated through the Src/SHP-1 tyrosine kinase signaling pathways (manuscript pending, experiments performed by Yulia Konarski, MSc candidate). NF- κ B has been previously implicated in the regulation of IL-12p40 expression (226) in murine macrophages and treatment with IFN- γ enhances this interactions. Using promoter assays, it would also be of interest to study the transcription factors responsible for regulating LPS-induced IL-23 subunits.

In summary, I show that LPS-induced IL-23 production is positively regulated by JNK and p38 MAPK, as well as the PI3K signalling pathways in THP-1 cells. The intracellular signalling mechanisms regulating IL-23 expression and the identification of the transcription factors involved in these pathways will be important steps in characterizing the function of this important pro-inflammatory cytokine.

Regulation of IL-27 production in human monocytic cells

Regulation of IFN- γ -induced IL-27 production in human monocytic cells: Although IL-27 is a key immunoregulatory cytokine produced predominantly by monocytic cells (28, 197), very little is known regarding the signaling pathways and molecular mechanisms that govern the production of IL-27 in general and particularly following IFN- γ stimulation in human monocytic cells. IL-27 has been shown to be produced by human monocytic cells primed with IFN- γ and in response to a second stimulus such as LPS (227). My results show that IFN- γ alone without any second stimulus can induce IL-27p28 gene expression and IL-27 protein production by human monocytic cells. Moreover, I demonstrate for the first time that

IFN- γ -mediated IL-27 protein but not IL-27p28 gene expression is positively regulated by JNK MAPK and PI3K pathways, independent of the Jak/STAT pathway in human monocytes. Since the IL-27 EBI-3 gene was not induced in these cells following IFN- γ stimulation, our results suggest that IL-27p28 plays a prominent role in the synthesis of heterodimeric IL-27 protein by IFN- γ -stimulated human monocytic cells. The precise mechanism of how these two subunits are regulated to produce a secreted IL-27 protein needs to be addressed.

IFN- γ mediates its biological effects by activating the Jak/STAT-1 pathways (103, 105, 199). Since IFN- γ induced the expression of IL-27p28 mRNA as well as IL-27 protein production in both positively and negatively selected human monocytes, it was of interest to determine if IFN- γ -induced IL-27 expression occurred via the activation of Jak/STAT-1 pathway. My results show that the JAK/STAT-1 signalling pathway does not regulate IL-27p28 mRNA expression or IL-27 protein production in primary human monocytes. Since IFN- γ can mediate its effects via STAT-1-independent pathways (95, 103, 105, 216, 228), I examined whether IFN- γ induces IL-27 expression by an alternate pathway via the activation of PI3K and MAPKs.

The role of MAPKs in the regulation of IL-27 expression in human monocytes is not well understood. Theiler's murine encephalomyelitis virus infection of the RAW264.7 macrophage cell line induced IL-27p28 mRNA expression through JNK-MAPK activation (148). Results show that JNK and PI3Ks are essential intracellular signaling mediators for IFN- γ -induced IL-27 production in human monocytic cells. Whether IFN- γ activates MAPK and PI3K pathways via MyD88 leading to IL-27 induction in human monocytic cells remains to be established. IFN- γ has also been shown to signal via other STAT molecules such as

STAT3 or STAT5 (95, 106, 212, 229). The involvement of STAT-3 or STAT-5 in IFN- γ -induced IL-27 production needs further investigation.

The regulation of IL-27p28 and EBI-3 subunits has been investigated in human monocyte-derived DCs and murine bone-marrow derived macrophages. Interferon regulatory factor-3 (IRF-3) was shown to regulate IL-27p28 expression in human DCs (155). Furthermore, Myd88 regulated LPS-induced IL-27p28 expression through the activation of IRF-1 transcription factor in murine RAW264.7 macrophage cell line (192). In addition to TLR-4 ligand, LPS, TLR-2, TLR-3 and TLR7/8 ligands have also been shown to regulate IL-27 gene expression in human macrophages that was mediated by the synthesis of IFN- α and possibly through IRF-1 activation (156). Similarly, IFN- β -activated human DCs expressed IL-27p28 through the activation of IRF-1 (230). We have shown that monocytes responded to IFN- γ leading to IL-27p28 expression. Since IFN- γ did not induce significant expression of EBI3, I focused my studies on the regulation of IL-27p28 subunit. Results suggest that IFN- γ -induced IL-27p28 is not regulated by either Jak/STAT, MAPKs or the PI3K pathways.

The mechanisms by which IFN- γ -activated PI3K and JNK positively regulate IL-27 production remain unknown. IFN- γ activates several transcription factors in various cell types including IRF-1, IRF-8, PU.1, C/EBP, CIITA, IRF-9 and c-Jun in a STAT-1-dependent manner (213-215). IFN- γ has also been shown to activate STAT3, STAT5, NF- κ B and AP-1 in a STAT-1-independent manner (96, 216, 217). It remains to be determined if IFN- γ -induced IL-27 expression in human monocytic cells is regulated by the IRF transcription factors. A comprehensive examination of the downstream transcription factors involved in IFN- γ -induced IL-27 expression will provide further insight into the regulation of this

cytokine. In order to outline the involvement of IFN- γ -activated transcription factors required for IL-27 production, promoter analysis experiments need to be performed in primary monocytes.

I have also shown that IL-27p28 mRNA expression did not correlate with IL-27 protein production. Results show that although IFN- γ -induced IL-27p28 mRNA expression was not regulated by the PI3K or MAPKs pathways, IFN- γ -induced IL-27 protein was regulated by the JNK and PI3K pathways. It has been reported that in another heterocytokine member of the IL-12 cytokine family, IL-23, IL-23p19 mRNA levels are not associated with an increase in IL-23 production in response to LPS in other model systems (91, 110, 112, 231). Inhibition of specific p38 and JNK MAPKs as well as PI3K pathways resulting in an increased expression of LPS-induced IL-23p19 has been reported (110, 112, 138). However, inhibition of p38 MAPK was also shown to decrease LPS-induced IL-23 production (110, 138). These observations suggest that post-transcriptional or post-translational mechanisms may regulate expression of heterodimeric IL-27 protein synthesis and/or secretion. Several possible post-transcriptional and post-translational steps such as IL-27 subunit mRNA stability, protein translation, intracellular protein degradation and secretion of newly synthesized protein may be regulated by distinct signalling pathways. It is possible that the decrease in IL-27 protein production, despite an increase in IL-27p28 mRNA that we observed following inhibition of the JNK MAPK and PI3K signalling pathways may be attributed to post-transcriptional or post-translational activity. My results are summarized in Figure 7 of the discussion section.

I show for the first time that IFN- γ alone can induce IL-27 protein production and IL-27p28 expression. However, in contrast to IFN- γ -induced IL-27p28 expression, IFN- γ -

Figure 7 A model showing the signalling pathways involved in IL-27 induction following IFN- γ stimulation in human monocytic cells. IFN- γ stimulation initiates the oligomerization of its receptor subunit, IFNGR1 and IFNGR2, facilitating JAK activation and recruiting STAT to the receptor. Phosphorylated STAT is translocated to the nucleus. The IFN receptors have been shown to interact directly with the p85 subunit of PI3K, independently of JAK-mediated phosphorylation of the receptor (97, 98). IFNGR1 has also been shown to interact directly with MyD88 (99). Furthermore, IFN- γ has also been shown to activate JNK MAPK in macrophages (101), although the precise sequence of events leading to JNK MAPK activation is not known. My results suggest that PI3K and JNK MAPK positively regulate IL-27 induction in response to IFN- γ stimulation through the activation of a yet-identified transcription factor (TF). \uparrow indicates enhanced expression whereas \downarrow indicates decreased expression following the blockage of a pathway.

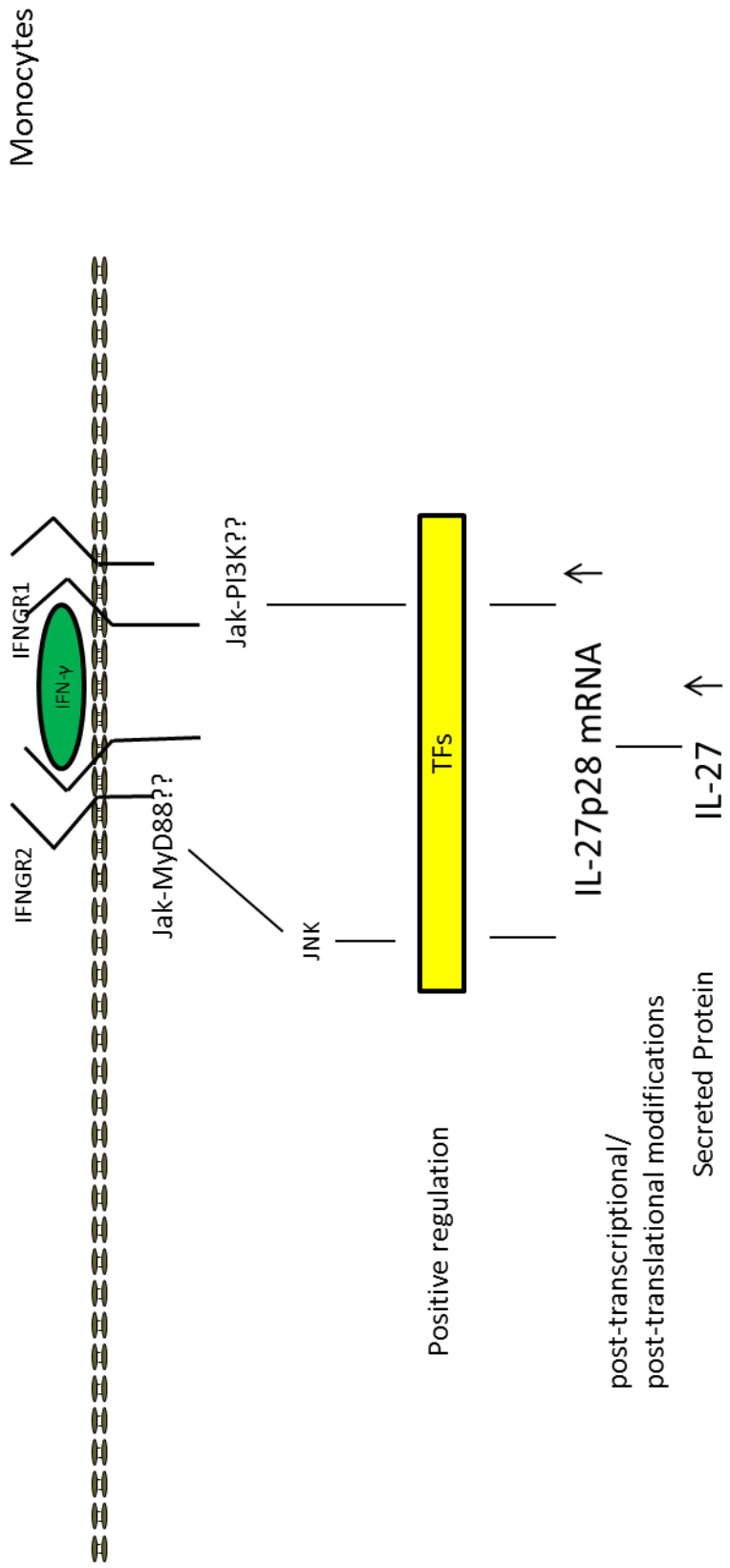

Figure 7

induced IL-27 protein production is selectively and positively regulated in primary human monocytes via the JNK MAPK and PI3K pathways independent of the Jak-STAT pathways. IL-27 production by monocytic cells in response to IFN- γ alone or in combination with other TLR agonists may modulate immune responses and host defences against pathogens, autoimmune diseases and cancer. Therefore, elucidating the mechanism of IFN- γ -induced regulation of IL-12 family cytokine expression, and particularly of IL-27, will further our understanding of immune responses in health and disease.

Regulation of LPS-induced IL-27 production in human myeloid cells: Keeping in mind that monocytes/macrophages are the most important sources of IL-27, very little is known regarding the intracellular signaling pathways and molecular mechanisms that govern the production of IL-27 in human monocytic cells. In particular, the regulation of IL-27 expression in LPS- and IFN- γ /LPS-stimulated human monocytic cells, THP-1 and MDMs remains poorly understood. Herein, I demonstrated for the first time that IFN- γ /LPS-induced IL-27 expression in human primary monocytes, THP-1 and MDMs is positively regulated by JNK MAPK and PI3K pathways. Our lab has also performed experiments where the IL-27 expression of human monocytes stimulated with IFN- γ /LPS-induced was analyzed. IFN- γ /LPS-induced IL-27 expression in human monocytes is regulated through JNK, p38 MAPK and PI3K (data not shown).

Stimulation of THP-1 cells with LPS resulted in an increase in IL-27p28 and IL-27EBI3 mRNA levels as well as increase in IL-27 protein production (Figure 4.2.1). Although IFN- γ induced IL-27p28 and EBI3 mRNA expression, THP-1 cells did not produce IL-27 proteins in response to stimulation with IFN- γ . These observations were similar to those observed indicating the necessity of priming cells with IFN- γ for LPS to induce IL-12 and L-

23 subunits expression in human monocytic cells (114, 115, 195). The combination of LPS and IFN- γ has also been shown to induce the expression of IL-27p28 and IL-27EBI3 mRNA in dendritic cells suggesting that priming of cells with IFN- γ is required for the production of high levels of IL-27 production in response to LPS stimulation (227). Similar to THP-1 cells, IFN- γ alone was not able to induce IL-27 expression at significant levels in MDMs. The fact that MDMs and THP-1 cells responded to produce significantly IL-27 p28, the mechanism for unresponsiveness of THP-1 cells and MDMs to produce IL-27 proteins to IFN- γ is not clear. Furthermore, studies have been initiated in our lab show that the src/shp-1 signalosome is responsible for regulation IL-27 expression in myeloid cells.

There is some information available regarding the molecular mechanism governing the regulation of IL-27p28 and EBI-3 subunits in different cell systems. LPS-induced IL-27p28 expression and IL-27 serum levels in LPS-injected mice were found to be critically dependent on Toll/IL-1R-containin adaptor-inducing IFN- β and its associated IFN regulatory factor (IRF) 3 transcription factor as demonstrated by promoter analysis (155). Involvement of IRF-3 was also shown to regulate IL-27p28 expression in human dendritic cells as shown by chromatin immunoprecipitation studies (155). In addition, MyD88 was shown to regulate LPS-induced IL-27p28 expression through the activation of IRF-1 transcription factor (192). These studies suggest that multiple signaling pathways may be required for IL-27 regulation. In addition to TLR-4 ligand, LPS, TLR-2, TLR-3 and TLR7/8 have also been shown to regulate IL-27 gene expression in human macrophages possibly through the synthesis of IFN- α (156). Furthermore, following stimulation of human DCs with IFN- β , IFN- β -activated DCs exhibited IL-27p28 expression and this was regulated through the activation of IRF-1 (230). The signaling pathways and the molecular mechanism that control IFN- γ or IFN-

γ /LPS-induced IL-27 expression have not been addressed. Since IRFs control IFN- γ -induced responses (213-215), it is possible that IFN- γ /LPS-induced IL-27 expression in human monocytic cells may be regulated by the IRF-1/3 transcription factors.

There is very little information available on the role of MAPKs in the regulation of IL-27 expression in human monocytes (87). Lara Hause *et al.* that have shown Theiler's murine encephalomyelitis virus infection of RAW264.7 cells, a macrophage cell line, induces IL-27p28 mRNA expression through TLR3 and TLR7 and JNK-MAPK activation (87). Pharmacological inhibitors and siRNA results suggest that JNK and p38 MAPKs are essential intracellular signaling mediators for IFN- γ - and IFN- γ /LPS-induced IL-27 production in human monocytic cells, MDMs and THP-1.

The MAPK signaling pathway has been extensively studied and is shown to operate in a variety of cell types. MAPK cascade involves a series of process signals from ligands and changes in cell state, affecting many cellular responses. Signaling by MAPKs affects specific events such as the activity or localization of individual proteins, transcription of genes, and increased cell cycle entry, while promotes changes in complex processes such as embryogenesis and differentiation. Furthermore, it has been shown that dysregulation of JNK and p38 MAPK is implicated in chronic inflammation, birth defects, cancer and neurodegeneration (232).

My results show that the IL-27p28 mRNA levels did not always correlate with IL-27 protein production specifically as seen in the JNK, p38 MAPK and PI3K inhibition studies in human monocytes and MDMs, following stimulation with either LPS alone or IFN- γ /LPS. This may indicate that post-transcriptional/post-translational mechanisms may govern the regulation of IL-27 expression and/or secretion in IFN- γ /LPS-stimulated monocytic cells and

MDMs. As mentioned earlier, IL-23p19 mRNA levels are not associated with an increase in IL-23 production in response to LPS in other model systems (91, 110, 112, 231). Inhibition of specific p38 and JNK MAPKs as well as PI3K pathways resulting in an increased expression of LPS-induced IL-23p19 has been reported (110, 112, 138). However, inhibition of p38 MAPK was also shown to decrease LPS-induced IL-23 production (110, 138). As I present in my proposed model in Figure, 8 LPS activates the CD14-TLR4-MD2 complex, which in turn activates the PI3K pathway (121), permitting docking of PI3K to the plasma membrane. Upon TLR4 activation, MyD88 is recruited to the TLR4 receptor and interacts with IL-1R-associated kinase (IRAK)-4 (125). IRAK4 will in turn activate other members of the IRAK family, resulting in the recruitment of TRAF6. This will activate a complex containing TGF- β -activated kinase (TAK1) and TAK1-binding proteins (TAB) (126). The TAK1/TAB complex triggers the MAPK and NF- κ B signaling pathways, including JNK and p38 MAPK (116). Studies have shown that LPS-TLR4 signaling in human monocytes also activates Akt (121). Akt may directly or indirectly activate MAPKs (121). My results suggest that PI3K, JNK and p38 MAPK positively regulate IL-27 induction in response to IFN- γ /LPS stimulation through the activation of a yet-identified transcription factor (TF).

As previously mentioned, there is considerable evidence to suggest that PI3K plays a key role in the regulation of IL-12p40 in human monocytic cells (27). My results in this study show that PI3K plays a crucial role in the regulation of IL-27 expression in primary human monocytes, MDMs as well as THP-1 cells following stimulation with LPS, IFN- γ or IFN- γ and LPS together. Overall, IFN- γ -induced IL-27 expression in human monocytes is positively regulated through JNK MAPK and PI3K signaling pathways, while IFN- γ /LPS-induced IL-27 expression in monocytes is governed through the p38 MAPK signaling pathway as well, through a JAK/STAT independent mechanism. The results obtained with

Figure 8 A model showing the signalling pathways involved in IL-27 induction following IFN- γ /LPS stimulation in THP-1 monocytic cells and MDMs. LPS is an outer wall component of Gram-negative bacteria that induces the production of many proinflammatory mediators in monocytes/macrophages (121). It activates the CD14-TLR4-MD2 complex, which in turn activates the PI3K pathway (121), permitting docking of PI3K to the plasma membrane. Upon TLR4 activation, MyD88 is recruited to the TLR4 receptor and interacts with IL-1R-associated kinase (IRAK)-4 (125). IRAK4 will in turn activate other members of the IRAK family, resulting in the recruitment of TRAF6. This will activate a complex containing TGF- β -activated kinase (TAK1) and TAK1-binding proteins (TAB) (126). The TAK1/TAB complex triggers the MAPK and NF- κ B signaling pathways, including JNK and p38 MAPK (116). Studies have shown that LPS-TLR4 signaling in human monocytes also activates Akt (121). Akt may directly or indirectly activate MAPKs (121). My results suggest that PI3K, JNK and p38 MAPK positively regulate IL-27 induction in response to IFN- γ /LPS stimulation through the activation of a yet-identified transcription factor (TF). \uparrow indicates enhanced expression whereas \downarrow indicates decreased expression following the blockage of a pathway.

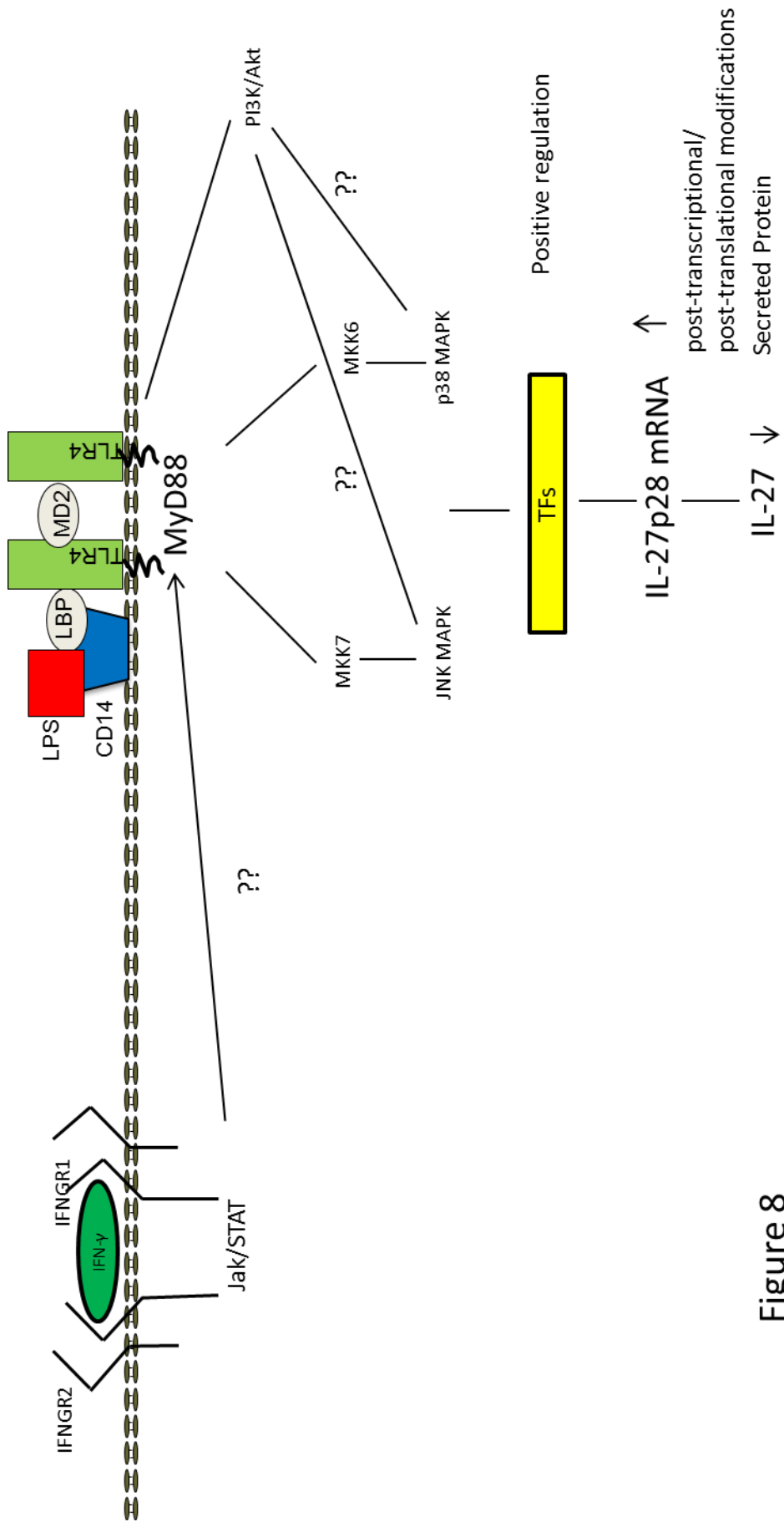

Figure 8

specific MAPK and PI3K inhibitors were confirmed using siRNA studies, which further establishes the role of these pathways to regulate LPS-induced IL-27 expression in myeloid-type cells.

In summary, I show that LPS-induced and IFN- γ /LPS-induced IL-27 expression is positively regulated through JNK, p38 MAPK and PI3K signaling pathways in MDMs. The differential regulation in LPS-induced of EBI3 and p28 mRNA indicated in my studies, further suggests that post-transcriptional or post-translational modifications that will be addressed in the following chapter.

mRNA-protein inconsistency in response to IFN- γ /LPS in human MDMs

My studies have focused on the transcriptional regulation of IL-23 and IL-27 subunits, while little is known about how they are regulated at the post-transcriptional level. While trying to address the complexity of the inconsistency between the IL-27p28 mRNA expression and IL-27 production levels, I showed that neither the lysosomal, nor the proteosomal degradation pathways are involved in the regulation of IL-27 (Results chapter 2.3). This led me to believe that perhaps mRNA post-translational stability may be involved. Post-translational regulation of many cytokines occurs via the modification of their mRNA stability through adenosine/uridine-rich elements (AREs) in the 3'UTR region. Tristetraprolin (TTP) is an RNA-binding protein whose role is to suppress inflammation by targeting cytokine mRNA for degradation. It binds to the AU-rich elements in the 3' untranslated region of the mRNA (233)(234). It is known that IL-23p19 has a long 3'-UTR that contains multiple adenosine/uridine-rich elements (AREs) (235), to which TTP is known to bind. It was of interest to find whether IL-27p28 also contains multiple AREs, making it a target for TTP binding. Recently it has been demonstrated that IFN- γ differentially regulates

IL-23 expression through TTP-mediated IL-23p19 mRNA degradation in murine macrophages and dendritic cells (235). This degradation may lead to Th17 cell suppression, adding another mechanism by which the immune system regulates proinflammatory responses. I have shown that stimulation with IFN- γ /LPS, as well as LPS alone can induce TTP mRNA expression in human MDMs (Results chapter 2.3). This induction may drive TTP to bind to the possible AREs sites on IL-27p28 mRNA, targeting it for degradation. This may explain why in spite of high mRNA expression levels, secreted protein levels are lower. However, further studies are necessary to confirm these results.

The mRNA-protein inconsistency and decreased secretion of IL-27 following LPS/IFN- γ stimulation may be because of the consumption of the secreted IL-27 and its subsequent utilization through the upregulated IL-27 R expression. Each cytokine has a matching cell-surface receptor, where upon binding the cell it triggers a cascade of intracellular signalling that can modulate cell functions, including the upregulation and/or downregulation of gene production and activation of transcription factors. This may result in the production of other cytokines, an increase in the number of surface receptors for other molecules, or the suppression of their own effects by feedback inhibition. In general, the effects that cytokines have on a given cell depend on the extracellular concentration of the cytokine, the abundance of its complementary receptor on the cell surface, and downstream signaling pathway. WSX-1 is a transmembrane protein that shares significant homology with gp130, making up the alpha chain of IL-27R (IL-27R α) (236). IL-27 binds to WSX-1, however gp130 is the additional receptor component of the full IL-27R, being the signal-transducing constituent of the IL-27 receptor. IL-27 α is expressing on a wide variety of cell types, including myeloid type (236). I have shown that stimulation with IFN- γ /LPS or LPS alone upregulated cell-surface expression of both WSX-1 and gp130 (Result chapter 2.3).

Furthermore, JNK MAPK negatively regulated the expression of both IL-27R components, while p38 MAPK and PI3K positively regulated their cell-surface expression (Results Chapter 5). Since IL-27R is upregulated upon stimulation with IFN- γ /LPS, it is possible that secreted IL-27 is being depleted out of the cellular milieu upon secretion and acting in an autocrine fashion. However, stimulation with LPS alone also resulted in an increase of IL-27 receptors expressing and IL-27 protein. In brief, although IL-27 receptor expression was upregulated, I did not observe the IL-27 mRNA-protein discrepancy in the same cells following LPS stimulation alone. I cannot conclude that enhanced IL-27 receptor expression is responsible for the mRNA-protein discrepancy. Further studies are necessary to address this issue.

The mRNA-protein inconsistency and decreased secretion of IL-27 following LPS/IFN- γ stimulation may also occur due to the impaired assembly of the IL-27 subunits intracellularly. As mentioned previously, cytokines are usually synthesized in the cytoplasm, translocated across the ER into the Golgi apparatus to the plasma membrane (2). Previous studies have shown that bioactive synthesis of IL-12 requires stoichiometric production of both subunits, while the p35 and p40 genes are regulated independently. As such, p35 subunit is expressed in a wide variety of cells, while p40 gene is expressed only in IL-12-secreting cells (237)(238). It is believed that biosynthesis of IL-12 is limited by the availability of its p35 subunit (239). Disulphide bond formation and assembly of p35 and p40 into the IL-12p70 heterocytokine occur in the ER. IL-12 is localized on the plasma membranes in human macrophages and dendritic cells (240)(241). Furthermore, it has been shown that the p35 subunit of IL-12 accumulates in the Golgi apparatus, and the cleavage of membrane-bound p35 may be a mechanism by which the immune system regulates bioactive IL-12 secretion (242). Since IL-12 like IL-23 and IL-27 is a heterodimeric cytokine, and

although, there are no reports on how IL-23 and IL-27 heterocytokines are assembled and secreted, it is possible that the synthesis and assembly of IL-23 and IL-27 may occur in a fashion analogous to that of IL-12.

The two subunits of the biologically active IL-23 are linked by disulphide bonds, similar to IL-12. The formation of these disulphide bonds is catalyzed by protein disulphide isomerase, an ER-resident enzyme. Therefore, I assume that IL-23 is also assembled in the ER. However, how IL-27 is assembled is not known keeping in view that IL-27 subunits are not disulfide bond linked. This adds another layer of complexity when trying to elucidate the mechanism responsible for IL-27 subunit assembly and secretion. Nonetheless, I speculate that the availability of one subunit namely the p19 and EBI3 subunits may be the determining factors in IL-23 and IL-27 synthesis, respectively.

Concluding remarks and future directions

Although the IL-12 cytokine family has been thoroughly implicated in a variety of autoimmune disease, cancer, HIV and HCV (84-86, 88-90, 148), the signaling pathways that regulate IL-23 and IL-27 production in human myeloid cells has been to date poorly described. Therefore, in order to study whether their dysregulation is involved in these diseases, one must first determine the mechanisms that govern their expression in healthy subjects.

As previously mentioned, IFN- γ treatment can prime cells to upregulate a variety of transcriptional activators after LPS stimulation. I have shown that IFN- γ /LPS treatment induces expression of all IL-12 cytokine family members in myeloid cells at a higher level than just LPS stimulation alone. It would be of interest to further study this priming

phenomenon and elucidate the reciprocal cross-regulation of signaling molecules governing the expression of IL-12, IL-23 and IL-27 in myeloid cells.

My studies have shown for the first time that IFN- γ -induced production of IL-23 in positively selected monocytes is positively regulated through the p38 MAPK pathway, while IL-27 production was positively regulated via JNK MAPK and PI3K pathway. I have also demonstrated that LPS-induced IL-23 and IL-27 production in the promonocytic THP-1 cell line is positively regulated through the JNK, p38 MAPK and PI3K signaling pathways. Furthermore, LPS or IFN- γ /LPS-induced production of IL-27 in MDMs is regulated via the JNK, p38 MAPK and PI3K signaling pathways, while IL-23 production did not seem to be regulated via these pathways. However, as previously mentioned, our laboratory has initiated further studies into the regulation of LPS-induced IL-23 regulation, and preliminary results show the SHP-1/src signalosome to be involved.

Primary cells, particularly monocytes, are notoriously hard to transfect, however it will be of interest to confirm these findings using siRNA or double-negative knock-outs or small hairpin RNA studies. Even though IFN- γ induced IL-27p28 mRNA levels, IL-27 protein production was not induced. Studies have been initiated where src/SHP-1 pathway may be involved in IFN- γ -stimulated IL-27 production in MDMs. Furthermore, our studies also show that the cellular inhibitor of apoptosis (cIAP) 1 and 2 may complex with the src/SHP-1 signalosome and regulate IL-27 expression in human MDMs. It would be important to continue these studies, in an effort to gain further insight on the regulation of the IL-12 family of cytokines in response to TLR4 engagement.

My results also suggest that the Jak/STAT signaling pathway is not involved in the positive regulation of either IFN- γ alone or in IFN- γ /LPS-stimulated human monocytes or MDMs. While Jak/STAT-independent IFN- γ signaling has been described, it would be

interesting to further study the role of Jak/STAT-independent signaling and how it cross-talks with the other pathways, in particular PI3K and MAPKs.

Furthermore, the transcription factors involved in the synthesis of IL-23 and IL-27 following IFN- γ /LPS stimulation need to be identified. By performing promoter analysis assays, these transcription factors can be elucidated. CHOP, an endoplasmic reticulum stress-induced transcription factor, has been shown to bind to the IL-23 promoter and plays a key role IL-23 expression in human DCs (243). In this study, infection of myeloid cells with *Chlamydia trachomatis* resulted in the expression of CHOP mRNA and induced the binding of CHOP to the IL-23 promoter. Knockdown of CHOP significantly reduced the expression of IL-23 in response to this intracellular bacterium (243). As such, it would be of great interest to elucidate the transcription factors involved in regulation of IL-23 and IL-27, because it will give us greater insight of the effects that pathogens have on the innate and adaptive immune responses.

My studies have also shown an inconsistency between the mRNA and protein levels in IL-23 and IL-27 protein expression in both monocytes and MDMs and these findings are summarized in Figure 8 of the discussion section, as well as in Tables 3 and 4. Namely, when JNK, p38 MAPK or PI3K signaling pathways are inhibited and positively regulate IL-23 and IL-27 protein production, the mRNA levels of IL-23p19 and IL-27p28 are either negatively regulated or stay the same. This mRNA-protein discrepancy described both in IL-23 and IL-27 expression needs to be addressed. While my results suggest that the proteosomal or lysosomal pathways may not be involved in the negative correlation between mRNA and protein expression levels, I show that mRNA stability and uptake of IL-27 protein through its receptors may explain this phenomenon. It will be of interest to further

investigate the role of various signaling molecules in synthesis, assembly and the secretion mechanisms governing the regulation of IL-23 and IL-27 subunit and their proteins.

I have also shown that stimulation with IFN- γ /LPS, as well as LPS alone can induce TTP mRNA expression in human MDMs. As previously mentioned, this induction may drive TTP to bind to the possible AREs sites on IL-27p28 mRNA, targeting it for degradation, lowering the levels of secreted IL-27 protein. siRNA TTP studies may confirm whether the by inhibiting this degradation of IL-27p28 may confirm this hypothesis.

Next, it also the question of why different pathways respond to the same stimulus in different cells, particularly IL-23 regulation, needs to be addressed. The activating kinases and phosphatase upstream of PI3K and MAPK signaling need to be identified. As mentioned, studied have been initiated that oversee the role of tyrosine kinases play in the regulation of the IL-23 family of cytokines in myeloid cells.

In conclusion, my studies attempted to identify the pathways that govern the regulation of IL-23 and IL-27 in human myeloid cells. This is important to the critical role of the IL-12 family of cytokines in coordinating immune responses and host defenses against invading pathogens.

Table 3. Regulation of IL-23 in response to IFN- γ /LPS in myeloid cells.

IL-23	Stimulus			
	Signaling Pathways	IFN-γ	LPS	IFN-γ/LPS
Monocytes	PI3K	- Negatively regulates IL-23p19 mRNA expression - Negatively regulates IL-12p40 and IL-23 protein production	Not Applicable	Not Applicable
	JNK MAPK	- Negatively regulates IL-23p19 mRNA expression - Negatively regulates IL-12p40 and IL-23 protein production		
	P38 MAPK	- Negatively regulates IL-23p19 mRNA expression - Positively regulates IL-12p40 and IL-23 protein production		
	JAK/STAT	- Negatively regulates IL-23p19 mRNA expression - Negatively regulates IL-12p40 and IL-23 protein production		
THP-1	PI3K MAPK	No induction/effect	- Positively regulates IL-12p40 and IL-23 protein production	Not Applicable
	JNK MAPK	No induction/effect	- Negatively regulates IL-23p19 mRNA expression - Positively regulates IL-12p40 and IL-23 protein production	
	P38 MAPK	No induction/effect	- Negatively regulates IL-23p19 mRNA expression - Positively regulates IL-12p40 and IL-23 protein production	
	JAK/STAT	No induction/effect		
MDMs	PI3K MAPK	No induction/effect	No apparent role in regulation	No apparent role in regulation
	JNK MAPK	No induction/effect	No apparent role in regulation	No apparent role in regulation
	P38 MAPK	No induction/effect	No apparent role in regulation	No apparent role in regulation
	JAK/STAT	No induction/effect	No apparent role in regulation	No apparent role in regulation

Table 4. Regulation of IL-27 in response to IFN- γ /LPS in myeloid cells.

IL-27	Stimulus			
	Signaling Pathways	IFN-γ	LPS	IFN-γ/LPS
Monocytes	PI3K	- Positively regulates IL-27 protein production	Not Applicable	Not Applicable
	JNK MAPK	- Positively regulates IL-27 protein production		
	P38 MAPK	No apparent role in regulation		
	JAK/STAT	No apparent role in regulation		
THP-1	PI3K MAPK	No induction/effect	- Positively regulates IL-27p28 mRNA expression - Positively regulates IL-27 protein production	Not Applicable
	JNK MAPK	No induction/effect	- Positively regulates IL-27 protein production	
	P38 MAPK	No induction/effect	- Positively regulates IL-27p28 mRNA expression - Positively regulates IL-27 protein production	
	JAK/STAT	No induction/effect		
MDMs	PI3K MAPK	No induction/effect	- Positively regulates IL-27p28 mRNA expression - Positively regulates IL-27 protein production	- Positively regulates IL-27 protein production
	JNK MAPK	No induction/effect	- Positively regulates IL-27p28 mRNA expression - Positively regulates IL-27 protein production	- Positively regulates IL-27 protein production
	P38 MAPK	No induction/effect	- Positively regulates IL-27p28 mRNA expression - Positively regulates IL-27 protein production	- Positively regulates IL-27 protein production
	JAK/STAT	No induction/effect	- Positively regulates IL-27p28 mRNA expression - Positively regulates IL-27 protein production	No apparent role in regulation

Contribution of Collaborators

I would like to thank Dr. Sunita Pandey and Mansi Saxena for all their help with the siRNA experiments, Figures 1.2.4, 1.2.5, 1.2.7, 2.2.4, 2.2.6, 2.2.11.

Regulation of LPS-induced IL-23 and IL-27 expression in THP-1 experiments were performed by Ali Rahimi, a fellow PhD student, Figures 1.2.1, 1.2.2, 1.2.3, 1.2.6, 2.2.1, 2.2.3, 2.2.5, 2.2.10.

Characterization of monocyte-derived macrophages was done by Aurelia Busca, Figure 1.3.1.

References

1. Stow, J. L., P. C. Low, C. Offenhauser, and D. Sangermani. 2009. Cytokine secretion in macrophages and other cells: pathways and mediators. *Immunobiology* 214: 601-612.
2. Stanley, A. C. and P. Lacy. 2010. Pathways for cytokine secretion. *Physiology (Bethesda)* 25: 218-229.
3. Duitman, E. H., Z. Orinska, and S. Bulfone-Paus. 2011. Mechanisms of cytokine secretion: a portfolio of distinct pathways allows flexibility in cytokine activity. *Eur. J. Cell Biol.* 90: 476-483.
4. Ma, X. and G. Trinchieri. 2001. Regulation of interleukin-12 production in antigen-presenting cells. *Adv. Immunol.* 79: 55-92.
5. Hunter, C. A. 2005. New IL-12-family members: IL-23 and IL-27, cytokines with divergent functions. *Nat. Rev. Immunol.* 5: 521-531.
6. Langrish, C. L., B. S. McKenzie, N. J. Wilson, R. de Waal Malefyt, R. A. Kastelein, and D. J. Cua. 2004. IL-12 and IL-23: master regulators of innate and adaptive immunity. *Immunol. Rev.* 202: 96-105.
7. Novelli, F. and J. L. Casanova. 2004. The role of IL-12, IL-23 and IFN-gamma in immunity to viruses. *Cytokine Growth Factor Rev.* 15: 367-377.
8. Robinson, D. S. and A. O'Garra. 2002. Further checkpoints in Th1 development. *Immunity* 16: 755-758.
9. Kato, T., R. Hakamada, H. Yamane, and H. Nariuchi. 1996. Induction of IL-12 p40 messenger RNA expression and IL-12 production of macrophages via CD40-CD40 ligand interaction. *J. Immunol.* 156: 3932-3938.
10. Ma, W., K. Gee, W. Lim, K. Chambers, J. B. Angel, M. Kozlowski, and A. Kumar. 2004. Dexamethasone inhibits IL-12p40 production in lipopolysaccharide-stimulated human monocytic cells by down-regulating the activity of c-Jun N-terminal kinase, the activation protein-1, and NF-kappa B transcription factors. *J. Immunol.* 172: 318-330.
11. Plevy, S. E., J. H. Gemberling, S. Hsu, A. J. Dorner, and S. T. Smale. 1997. Multiple control elements mediate activation of the murine and human interleukin 12 p40 promoters: evidence of functional synergy between C/EBP and Rel proteins. *Mol. Cell. Biol.* 17: 4572-4588.
12. Utsugi, M., K. Dobashi, T. Ishizuka, K. Endou, J. Hamuro, Y. Murata, T. Nakazawa, and M. Mori. 2003. c-Jun N-terminal kinase negatively regulates lipopolysaccharide-induced IL-

- 12 production in human macrophages: role of mitogen-activated protein kinase in glutathione redox regulation of IL-12 production. *J. Immunol.* 171: 628-635.
13. Cooper, A. M. and S. A. Khader. 2007. IL-12p40: an inherently agonistic cytokine. *Trends Immunol.* 28: 33-38.
14. Aste-Amezaga, M., X. Ma, A. Sartori, and G. Trinchieri. 1998. Molecular mechanisms of the induction of IL-12 and its inhibition by IL-10. *J. Immunol.* 160: 5936-5944.
15. Yan, J. J., R. Wang, Y. Z. Wang, and W. B. Zhou. 2008. Expression of EBI3 and p28 mRNA in the brain and spinal cord of chronic model of experimental autoimmune encephalomyelitis in C57BL/6J mice. *Zhong Nan Da Xue Xue Bao Yi Xue Ban* 33: 1028-1036.
16. Krumbiegel, D., C. Anthogalidis-Voss, H. Markus, F. Zepp, and C. U. Meyer. 2008. Enhanced expression of IL-27 mRNA in human newborns. *Pediatr. Allergy Immunol.* 19: 513-516.
17. Li, J., B. Gran, G. X. Zhang, E. S. Ventura, I. Siglienti, A. Rostami, and M. Kamoun. 2003. Differential expression and regulation of IL-23 and IL-12 subunits and receptors in adult mouse microglia. *J. Neurol. Sci.* 215: 95-103.
18. Al-Salleeh, F. and T. M. Petro. 2008. Promoter analysis reveals critical roles for SMAD-3 and ATF-2 in expression of IL-23 p19 in macrophages. *J. Immunol.* 181: 4523-4533.
19. Hunter, C. A. 2005. New IL-12-family members: IL-23 and IL-27, cytokines with divergent functions. *Nat. Rev. Immunol.* 5: 521-531.
20. Hume, D. A., C. A. Wells, and T. Ravasi. 2007. Transcriptional regulatory networks in macrophages. *Novartis found. Symp.* 281: 2-18; discussion 18-24, 50-3, 208-9.
21. Stow, J. L., P. C. Low, C. Offenhauser, and D. Sangermani. 2009. Cytokine secretion in macrophages and other cells: pathways and mediators. *Immunobiology* 214: 601-612.
22. Matikainen, S., A. Paananen, M. Miettinen, M. Kurimoto, T. Timonen, I. Julkunen, and T. Sareneva. 2001. IFN-alpha and IL-18 synergistically enhance IFN-gamma production in human NK cells: differential regulation of Stat4 activation and IFN-gamma gene expression by IFN-alpha and IL-12. *Eur. J. Immunol.* 31: 2236-2245.
23. Trinchieri, G. 2003. Interleukin-12 and the regulation of innate resistance and adaptive immunity. *Nat. Rev. Immunol.* 3: 133-146.
24. Carra, G., F. Gerosa, and G. Trinchieri. 2000. Biosynthesis and posttranslational regulation of human IL-12. *J. Immunol.* 164: 4752-4761.

25. Collison, L. W. and D. A. Vignali. 2008. Interleukin-35: odd one out or part of the family? *Immunol. Rev.* 226: 248-262.
26. Pflanz, S., J. C. Timans, J. Cheung, R. Rosales, H. Kanzler, J. Gilbert, L. Hibbert, T. Churakova, M. Travis, E. Vaisberg, W. M. Blumenschein, J. D. Mattson, J. L. Wagner, W. To, S. Zurawski, T. K. McClanahan, D. M. Gorman, J. F. Bazan, R. de Waal Malefyt, D. Rennick, and R. A. Kastelein. 2002. IL-27, a heterodimeric cytokine composed of EBI3 and p28 protein, induces proliferation of naive CD4(+) T cells. *Immunity* 16: 779-790.
27. Utsugi, M., K. Dobashi, A. Ono, T. Ishizuka, S. Matsuzaki, T. Hisada, Y. Shimizu, T. Kawata, H. Aoki, Y. Kamide, and M. Mori. 2009. PI3K p110beta positively regulates lipopolysaccharide-induced IL-12 production in human macrophages and dendritic cells and JNK1 plays a novel role. *J. Immunol.* 182: 5225-5231.
28. Kastelein, R. A., C. A. Hunter, and D. J. Cua. 2007. Discovery and biology of IL-23 and IL-27: related but functionally distinct regulators of inflammation. *Annu. Rev. Immunol.* 25: 221-242.
29. D'Andrea, A., M. Aste-Amezaga, N. M. Valiante, X. Ma, M. Kubin, and G. Trinchieri. 1993. Interleukin 10 (IL-10) inhibits human lymphocyte interferon gamma-production by suppressing natural killer cell stimulatory factor/IL-12 synthesis in accessory cells. *J. Exp. Med.* 178: 1041-1048.
30. Driessler, F., K. Venstrom, R. Sabat, K. Asadullah, and A. J. Schottelius. 2004. Molecular mechanisms of interleukin-10-mediated inhibition of NF-kappaB activity: a role for p50. *Clin. Exp. Immunol.* 135: 64-73.
31. Rahim, S. S., N. Khan, C. S. Boddupalli, S. E. Hasnain, and S. Mukhopadhyay. 2005. Interleukin-10 (IL-10) mediated suppression of IL-12 production in RAW 264.7 cells also involves c-rel transcription factor. *Immunology* 114: 313-321.
32. Alber, G., S. Al-Robaiy, M. Kleinschek, J. Knauer, P. Krumbholz, J. Richter, S. Schoeneberger, N. Schuetze, S. Schulz, K. Toepfer, R. Voigtlaender, J. Lehmann, and U. Mueller. 2006. Induction of immunity and inflammation by interleukin-12 family members. *Ernst Schering Res. found. Workshop* (56): 107-127.
33. Oppmann, B., R. Lesley, B. Blom, J. C. Timans, Y. Xu, B. Hunte, F. Vega, N. Yu, J. Wang, K. Singh, F. Zonin, E. Vaisberg, T. Churakova, M. Liu, D. Gorman, J. Wagner, S. Zurawski, Y. Liu, J. S. Abrams, K. W. Moore, D. Rennick, R. de Waal-Malefyt, C. Hannum, J. F. Bazan, and R. A. Kastelein. 2000. Novel p19 protein engages IL-12p40 to form a cytokine, IL-23, with biological activities similar as well as distinct from IL-12. *Immunity* 13: 715-725.
34. Belladonna, M. L., J. C. Renauld, R. Bianchi, C. Vacca, F. Fallarino, C. Orabona, M. C. Fioretti, U. Grohmann, and P. Puccetti. 2002. IL-23 and IL-12 have overlapping, but distinct, effects on murine dendritic cells. *J. Immunol.* 168: 5448-5454.

35. Grohmann, U., M. L. Belladonna, C. Vacca, R. Bianchi, F. Fallarino, C. Orabona, M. C. Fioretti, and P. Puccetti. 2001. Positive regulatory role of IL-12 in macrophages and modulation by IFN-gamma. *J. Immunol.* 167: 221-227.
36. Grohmann, U., M. L. Belladonna, R. Bianchi, C. Orabona, E. Ayroldi, M. C. Fioretti, and P. Puccetti. 1998. IL-12 acts directly on DC to promote nuclear localization of NF-kappaB and primes DC for IL-12 production. *Immunity* 9: 315-323.
37. Brombacher, F., R. A. Kastelein, and G. Alber. 2003. Novel IL-12 family members shed light on the orchestration of Th1 responses. *Trends Immunol.* 24: 207-212.
38. Gee, K., C. Guzzo, N. F. Che Mat, W. Ma, and A. Kumar. 2009. The IL-12 family of cytokines in infection, inflammation and autoimmune disorders. *Inflamm. Allergy Drug Targets* 8: 40-52.
39. Aggarwal, S., N. Ghilardi, M. H. Xie, F. J. de Sauvage, and A. L. Gurney. 2003. Interleukin-23 promotes a distinct CD4 T cell activation state characterized by the production of interleukin-17. *J. Biol. Chem.* 278: 1910-1914.
40. McKenzie, B. S., R. A. Kastelein, and D. J. Cua. 2006. Understanding the IL-23-IL-17 immune pathway. *Trends Immunol.* 27: 17-23.
41. Cua, D. J., J. Sherlock, Y. Chen, C. A. Murphy, B. Joyce, B. Seymour, L. Lucian, W. To, S. Kwan, T. Churakova, S. Zurawski, M. Wiekowski, S. A. Lira, D. Gorman, R. A. Kastelein, and J. D. Sedgwick. 2003. Interleukin-23 rather than interleukin-12 is the critical cytokine for autoimmune inflammation of the brain. *Nature* 421: 744-748.
42. Ding, C., J. Xu, and J. Li. 2008. ABT-874, a fully human monoclonal anti-IL-12/IL-23 antibody for the potential treatment of autoimmune diseases. *Curr. Opin. Investig Drugs* 9: 515-522.
43. Krueger, G. G., R. G. Langley, C. Leonardi, N. Yeilding, C. Guzzo, Y. Wang, L. T. Dooley, M. Lebwohl, and CNTO 1275 Psoriasis Study Group. 2007. A human interleukin-12/23 monoclonal antibody for the treatment of psoriasis. *N. Engl. J. Med.* 356: 580-592.
44. Kamada, N., T. Hisamatsu, S. Okamoto, H. Chinen, T. Kobayashi, T. Sato, A. Sakuraba, M. T. Kitazume, A. Sugita, K. Koganei, K. S. Akagawa, and T. Hibi. 2008. Unique CD14 intestinal macrophages contribute to the pathogenesis of Crohn disease via IL-23/IFN-gamma axis. *J. Clin. Invest.* 118: 2269-2280.
45. Lee, E., W. L. Trepicchio, J. L. Oestreicher, D. Pittman, F. Wang, F. Chamian, M. Dhodapkar, and J. G. Krueger. 2004. Increased expression of interleukin 23 p19 and p40 in lesional skin of patients with psoriasis vulgaris. *J. Exp. Med.* 199: 125-130.

46. Murphy, C. A., C. L. Langrish, Y. Chen, W. Blumenschein, T. McClanahan, R. A. Kastelein, J. D. Sedgwick, and D. J. Cua. 2003. Divergent pro- and antiinflammatory roles for IL-23 and IL-12 in joint autoimmune inflammation. *J. Exp. Med.* 198: 1951-1957.
47. Yen, D., J. Cheung, H. Scheerens, F. Poulet, T. McClanahan, B. McKenzie, M. A. Kleinschek, A. Owyang, J. Mattson, W. Blumenschein, E. Murphy, M. Sathe, D. J. Cua, R. A. Kastelein, and D. Rennick. 2006. IL-23 is essential for T cell-mediated colitis and promotes inflammation via IL-17 and IL-6. *J. Clin. Invest.* 116: 1310-1316.
48. Happel, K. I., M. Zheng, E. Young, L. J. Quinton, E. Lockhart, A. J. Ramsay, J. E. Shellito, J. R. Schurr, G. J. Bagby, S. Nelson, and J. K. Kolls. 2003. Cutting edge: roles of Toll-like receptor 4 and IL-23 in IL-17 expression in response to *Klebsiella pneumoniae* infection. *J. Immunol.* 170: 4432-4436.
49. Kleinschek, M. A., U. Muller, S. J. Brodie, W. Stenzel, G. Kohler, W. M. Blumenschein, R. K. Straubinger, T. McClanahan, R. A. Kastelein, and G. Alber. 2006. IL-23 enhances the inflammatory cell response in *Cryptococcus neoformans* infection and induces a cytokine pattern distinct from IL-12. *J. Immunol.* 176: 1098-1106.
50. Piskin, G., R. M. Sylva-Steenland, J. D. Bos, and M. B. Teunissen. 2006. In vitro and in situ expression of IL-23 by keratinocytes in healthy skin and psoriasis lesions: enhanced expression in psoriatic skin. *J. Immunol.* 176: 1908-1915.
51. Li, Y., N. Chu, A. Hu, B. Gran, A. Rostami, and G. X. Zhang. 2008. Inducible IL-23p19 expression in human microglia via p38 MAPK and NF-kappaB signal pathways. *Exp. Mol. Pathol.* 84: 1-8.
52. Watford, W. T., B. D. Hissong, J. H. Bream, Y. Kanno, L. Muul, and J. J. O'Shea. 2004. Signaling by IL-12 and IL-23 and the immunoregulatory roles of STAT4. *Immunol. Rev.* 202: 139-156.
53. Parham, C., M. Chirica, J. Timans, E. Vaisberg, M. Travis, J. Cheung, S. Pflanz, R. Zhang, K. P. Singh, F. Vega, W. To, J. Wagner, A. M. O'Farrell, T. McClanahan, S. Zurawski, C. Hannum, D. Gorman, D. M. Rennick, R. A. Kastelein, R. de Waal Malefyt, and K. W. Moore. 2002. A receptor for the heterodimeric cytokine IL-23 is composed of IL-12Rbeta1 and a novel cytokine receptor subunit, IL-23R. *J. Immunol.* 168: 5699-5708.
54. Mangan, P. R., L. E. Harrington, D. B. O'Quinn, W. S. Helms, D. C. Bullard, C. O. Elson, R. D. Hatton, S. M. Wahl, T. R. Schoeb, and C. T. Weaver. 2006. Transforming growth factor-beta induces development of the T(H)17 lineage. *Nature* 441: 231-234.
55. Zhou, L., I. I. Ivanov, R. Spolski, R. Min, K. Shenderov, T. Egawa, D. E. Levy, W. J. Leonard, and D. R. Littman. 2007. IL-6 programs T(H)-17 cell differentiation by promoting sequential engagement of the IL-21 and IL-23 pathways. *Nat. Immunol.* 8: 967-974.

56. Wiekowski, M. T., M. W. Leach, E. W. Evans, L. Sullivan, S. C. Chen, G. Vassileva, J. F. Bazan, D. M. Gorman, R. A. Kastelein, S. Narula, and S. A. Lira. 2001. Ubiquitous transgenic expression of the IL-23 subunit p19 induces multiorgan inflammation, runting, infertility, and premature death. *J. Immunol.* 166: 7563-7570.
57. Coulomb-L'Hermine, A., F. Larousserie, S. Pflanz, E. Bardel, R. A. Kastelein, and O. Devergne. 2007. Expression of interleukin-27 by human trophoblast cells. *Placenta* 28: 1133-1140.
58. Batten, M. and N. Ghilardi. 2007. The biology and therapeutic potential of interleukin 27. *J. Mol. Med. (Berl)* 85: 661-672.
59. Taga, T. 1997. The signal transducer gp130 is shared by interleukin-6 family of haematopoietic and neurotrophic cytokines. *Ann. Med.* 29: 63-72.
60. Sprecher, C. A., F. J. Grant, J. W. Baumgartner, S. R. Presnell, S. K. Schrader, T. Yamagiwa, T. E. Whitmore, P. J. O'Hara, and D. F. Foster. 1998. Cloning and characterization of a novel class I cytokine receptor. *Biochem. Biophys. Res. Commun.* 246: 82-90.
61. Artis, D., A. Villarino, M. Silverman, W. He, E. M. Thornton, S. Mu, S. Summer, T. M. Covey, E. Huang, H. Yoshida, G. Koretzky, M. Goldschmidt, G. D. Wu, F. de Sauvage, H. R. Miller, C. J. Saris, P. Scott, and C. A. Hunter. 2004. The IL-27 receptor (WSX-1) is an inhibitor of innate and adaptive elements of type 2 immunity. *J. Immunol.* 173: 5626-5634.
62. Pflanz, S., L. Hibbert, J. Mattson, R. Rosales, E. Vaisberg, J. F. Bazan, J. H. Phillips, T. K. McClanahan, R. de Waal Malefyt, and R. A. Kastelein. 2004. WSX-1 and glycoprotein 130 constitute a signal-transducing receptor for IL-27. *J. Immunol.* 172: 2225-2231.
63. Takeda, A., S. Hamano, A. Yamanaka, T. Hanada, T. Ishibashi, T. W. Mak, A. Yoshimura, and H. Yoshida. 2003. Cutting edge: role of IL-27/WSX-1 signaling for induction of T-bet through activation of STAT1 during initial Th1 commitment. *J. Immunol.* 170: 4886-4890.
64. Chiyo, M., O. Shimosato, L. Yu, K. Kawamura, T. Iizasa, T. Fujisawa, and M. Tagawa. 2005. Expression of IL-27 in murine carcinoma cells produces antitumor effects and induces protective immunity in inoculated host animals. *Int. J. Cancer* 115: 437-442.
65. Hisada, M., S. Kamiya, K. Fujita, M. L. Belladonna, T. Aoki, Y. Koyanagi, J. Mizuguchi, and T. Yoshimoto. 2004. Potent antitumor activity of interleukin-27. *Cancer Res.* 64: 1152-1156.
66. Salcedo, R., J. K. Stauffer, E. Lincoln, T. C. Back, J. A. Hixon, C. Hahn, K. Shafer-Weaver, A. Malyguine, R. Kastelein, and J. M. Wigginton. 2004. IL-27 mediates complete regression of orthotopic primary and metastatic murine neuroblastoma tumors: role for CD8+ T cells. *J. Immunol.* 173: 7170-7182.

67. Shimizu, S., N. Sugiyama, K. Masutani, A. Sadanaga, Y. Miyazaki, Y. Inoue, M. Akahoshi, R. Katafuchi, H. Hirakata, M. Harada, S. Hamano, H. Nakashima, and H. Yoshida. 2005. Membranous glomerulonephritis development with Th2-type immune deviations in MRL/lpr mice deficient for IL-27 receptor (WSX-1). *J. Immunol.* 175: 7185-7192.
68. Oniki, S., H. Nagai, T. Horikawa, J. Furukawa, M. L. Belladonna, T. Yoshimoto, I. Hara, and C. Nishigori. 2006. Interleukin-23 and interleukin-27 exert quite different antitumor and vaccine effects on poorly immunogenic melanoma. *Cancer Res.* 66: 6395-6404.
69. Shimizu, M., M. Shimamura, T. Owaki, M. Asakawa, K. Fujita, M. Kudo, Y. Iwakura, Y. Takeda, A. D. Luster, J. Mizuguchi, and T. Yoshimoto. 2006. Antiangiogenic and antitumor activities of IL-27. *J. Immunol.* 176: 7317-7324.
70. Larousserie, F., S. Pflanz, A. Coulomb-L'Hermine, N. Brousse, R. Kastelein, and O. Devergne. 2004. Expression of IL-27 in human Th1-associated granulomatous diseases. *J. Pathol.* 202: 164-171.
71. Yoshimura, T., A. Takeda, S. Hamano, Y. Miyazaki, I. Kinjyo, T. Ishibashi, A. Yoshimura, and H. Yoshida. 2006. Two-sided roles of IL-27: induction of Th1 differentiation on naive CD4+ T cells versus suppression of proinflammatory cytokine production including IL-23-induced IL-17 on activated CD4+ T cells partially through STAT3-dependent mechanism. *J. Immunol.* 177: 5377-5385.
72. Amadi-Obi, A., C. R. Yu, X. Liu, R. M. Mahdi, G. L. Clarke, R. B. Nussenblatt, I. Gery, Y. S. Lee, and C. E. Egwuagu. 2007. TH17 cells contribute to uveitis and scleritis and are expanded by IL-2 and inhibited by IL-27/STAT1. *Nat. Med.* 13: 711-718.
73. Ishigame, H., A. Nakajima, S. Saijo, Y. Komiyama, A. Nambu, T. Matsuki, S. Nakae, R. Horai, S. Kakuta, and Y. Iwakura. 2006. The role of TNF α and IL-17 in the development of excess IL-1 signaling-induced inflammatory diseases in IL-1 receptor antagonist-deficient mice. *Ernst Schering Res. found. Workshop* top: 129-153.
74. Villarino, A., L. Hibbert, L. Lieberman, E. Wilson, T. Mak, H. Yoshida, R. A. Kastelein, C. Saris, and C. A. Hunter. 2003. The IL-27R (WSX-1) is required to suppress T cell hyperactivity during infection. *Immunity* 19: 645-655.
75. Villarino, A. V., J. S. Stumhofer, C. J. Saris, R. A. Kastelein, F. J. de Sauvage, and C. A. Hunter. 2006. IL-27 limits IL-2 production during Th1 differentiation. *J. Immunol.* 176: 237-247.
76. Schmidt, C., T. Giese, B. Ludwig, I. Mueller-Molaian, T. Marth, S. Zeuzem, S. C. Meuer, and A. Stallmach. 2005. Expression of interleukin-12-related cytokine transcripts in inflammatory bowel disease: elevated interleukin-23p19 and interleukin-27p28 in Crohn's disease but not in ulcerative colitis. *Inflamm. Bowel Dis.* 11: 16-23.

77. Devergne, O., M. Birkenbach, and E. Kieff. 1997. Epstein-Barr virus-induced gene 3 and the p35 subunit of interleukin 12 form a novel heterodimeric hematopoietin. *Proc. Natl. Acad. Sci. U. S. A.* 94: 12041-12046.
78. Niedbala, W., X. Q. Wei, B. Cai, A. J. Hueber, B. P. Leung, I. B. McInnes, and F. Y. Liew. 2007. IL-35 is a novel cytokine with therapeutic effects against collagen-induced arthritis through the expansion of regulatory T cells and suppression of Th17 cells. *Eur. J. Immunol.* 37: 3021-3029.
79. Imamichi, T., J. Yang, D. W. Huang, T. W. Brann, B. A. Fullmer, J. W. Adelsberger, R. A. Lempicki, M. W. Baseler, and H. C. Lane. 2008. IL-27, a novel anti-HIV cytokine, activates multiple interferon-inducible genes in macrophages. *AIDS* 22: 39-45.
80. Fakruddin, J. M., R. A. Lempicki, R. J. Gorelick, J. Yang, J. W. Adelsberger, A. J. Garcia-Pineres, L. A. Pinto, H. C. Lane, and T. Imamichi. 2007. Noninfectious papilloma virus-like particles inhibit HIV-1 replication: implications for immune control of HIV-1 infection by IL-27. *Blood* 109: 1841-1849.
81. Matsui, M., O. Moriya, M. L. Belladonna, S. Kamiya, F. A. Lemonnier, T. Yoshimoto, and T. Akatsuka. 2004. Adjuvant activities of novel cytokines, interleukin-23 (IL-23) and IL-27, for induction of hepatitis C virus-specific cytotoxic T lymphocytes in HLA-A*0201 transgenic mice. *J. Virol.* 78: 9093-9104.
82. Guzzo, C., W. M. Hopman, N. F. Che Mat, W. Wobeser, and K. Gee. 2010. Impact of HIV infection, highly active antiretroviral therapy, and hepatitis C coinfection on serum interleukin-27. *AIDS* 24: 1371-1374.
83. Butchar, J. P., K. V. Parsa, C. B. Marsh, and S. Tridandapani. 2008. IFN γ enhances IL-23 production during Francisella infection of human monocytes. *FEBS Lett.* 582: 1044-1048.
84. Siegemund, S., N. Schutze, M. A. Freudenberg, M. B. Lutz, R. K. Straubinger, and G. Alber. 2007. Production of IL-12, IL-23 and IL-27p28 by bone marrow-derived conventional dendritic cells rather than macrophages after LPS/TLR4-dependent induction by Salmonella Enteritidis. *Immunobiology* 212: 739-750.
85. Fedele, G., M. Nasso, F. Spensieri, R. Palazzo, L. Frasca, M. Watanabe, and C. M. Ausiello. 2008. Lipopolysaccharides from Bordetella pertussis and Bordetella parapertussis differently modulate human dendritic cell functions resulting in divergent prevalence of Th17-polarized responses. *J. Immunol.* 181: 208-216.
86. Yang, C. S., C. H. Song, J. S. Lee, S. B. Jung, J. H. Oh, J. Park, H. J. Kim, J. K. Park, T. H. Paik, and E. K. Jo. 2006. Intracellular network of phosphatidylinositol 3-kinase, mammalian target of the rapamycin/70 kDa ribosomal S6 kinase 1, and mitogen-activated protein kinases pathways for regulating mycobacteria-induced IL-23 expression in human macrophages. *Cell. Microbiol.* 8: 1158-1171.

87. Hause, L., F. M. Al-Salleeh, and T. M. Petro. 2007. Expression of IL-27 p28 by Theiler's virus-infected macrophages depends on TLR3 and TLR7 activation of JNK-MAP-kinases. *Antiviral Res.* 76: 159-167.
88. Pirhonen, J., S. Matikainen, and I. Julkunen. 2002. Regulation of virus-induced IL-12 and IL-23 expression in human macrophages. *J. Immunol.* 169: 5673-5678.
89. Zhu, C., R. Zhang, L. Liu, S. T. Rasool, Y. Mu, W. Sun, Q. Hao, F. Liu, Y. Zhu, and J. Wu. 2009. Hepatitis B virus enhances interleukin-27 expression both in vivo and in vitro. *Clin. Immunol.* 131: 92-97.
90. Smits, H. H., A. J. van Beelen, C. Hessle, R. Westland, E. de Jong, E. Soeteman, A. Wold, E. A. Wierenga, and M. L. Kapsenberg. 2004. Commensal Gram-negative bacteria prime human dendritic cells for enhanced IL-23 and IL-27 expression and enhanced Th1 development. *Eur. J. Immunol.* 34: 1371-1380.
91. Waibler, Z., U. Kalinke, J. Will, M. H. Juan, J. M. Pfeilschifter, and H. H. Radeke. 2007. TLR-ligand stimulated interleukin-23 subunit expression and assembly is regulated differentially in murine plasmacytoid and myeloid dendritic cells. *Mol. Immunol.* 44: 1483-1489.
92. Milstone, L. M. and B. H. Waksman. 1970. Release of virus inhibitor from tuberculin-sensitized peritoneal cells stimulated by antigen. *J. Immunol.* 105: 1068-1071.
93. Schroder, K., P. J. Hertzog, T. Ravasi, and D. A. Hume. 2004. Interferon-gamma: an overview of signals, mechanisms and functions. *J. Leukoc. Biol.* 75: 163-189.
94. Briscoe, J., D. Guschin, N. C. Rogers, D. Watling, M. Muller, F. Horn, P. Heinrich, G. R. Stark, and I. M. Kerr. 1996. JAKs, STATs and signal transduction in response to the interferons and other cytokines. *Philos. Trans. R. Soc. Lond. B. Biol. Sci.* 351: 167-171.
95. Gough, D. J., D. E. Levy, R. W. Johnstone, and C. J. Clarke. 2008. IFN γ signaling- does it mean JAK-STAT? *Cytokine Growth Factor Rev.* 19: 383-394.
96. Gough, D. J., K. Sabapathy, E. Y. Ko, H. A. Arthur, R. D. Schreiber, J. A. Trapani, C. J. Clarke, and R. W. Johnstone. 2007. A novel c-Jun-dependent signal transduction pathway necessary for the transcriptional activation of interferon gamma response genes. *J. Biol. Chem.* 282: 938-946.
97. Rani, M. R., L. Hibbert, N. Sizemore, G. R. Stark, and R. M. Ransohoff. 2002. Requirement of phosphoinositide 3-kinase and Akt for interferon-beta-mediated induction of the beta-R1 (SCYB11) gene. *J. Biol. Chem.* 277: 38456-38461.
98. Uddin, S., B. Majchrzak, P. C. Wang, S. Modi, M. K. Khan, E. N. Fish, and L. C. Platanius. 2000. Interferon-dependent activation of the serine kinase PI 3'-kinase requires

engagement of the IRS pathway but not the Stat pathway. *Biochem. Biophys. Res. Commun.* 270: 158-162.

99. Sun, D. and A. Ding. 2006. MyD88-mediated stabilization of interferon-gamma-induced cytokine and chemokine mRNA. *Nat. Immunol.* 7: 375-381.

100. Halfter, U. M., Z. E. Derbyshire, and R. R. Vaillancourt. 2005. Interferon-gamma-dependent tyrosine phosphorylation of MEKK4 via Pyk2 is regulated by annexin II and SHP2 in keratinocytes. *Biochem. J.* 388: 17-28.

101. Valledor, A. F., E. Sanchez-Tillo, L. Arpa, J. M. Park, C. Caelles, J. Lloberas, and A. Celada. 2008. Selective roles of MAPKs during the macrophage response to IFN-gamma. *J. Immunol.* 180: 4523-4529.

102. Sheikh, S. Z., K. Matsuoka, T. Kobayashi, F. Li, T. Rubinas, and S. E. Plevy. 2010. Cutting edge: IFN-gamma is a negative regulator of IL-23 in murine macrophages and experimental colitis. *J. Immunol.* 184: 4069-4073.

103. Gil, M. P., E. Bohn, A. K. O'Guin, C. V. Ramana, B. Levine, G. R. Stark, H. W. Virgin, and R. D. Schreiber. 2001. Biologic consequences of Stat1-independent IFN signaling. *Proc. Natl. Acad. Sci. U. S. A.* 98: 6680-6685.

104. Valledor, A. F., L. Arpa, E. Sanchez-Tillo, M. Comalada, C. Casals, J. Xaus, C. Caelles, J. Lloberas, and A. Celada. 2008. IFN- γ -mediated inhibition of MAPK phosphatase expression results in prolonged MAPK activity in response to M-CSF and inhibition of proliferation. *Blood* 112: 3274-3282.

105. Kaur, S., A. Sassano, A. M. Joseph, B. Majchrzak-Kita, E. A. Eklund, A. Verma, S. M. Brachmann, E. N. Fish, and L. C. Plataniias. 2008. Dual regulatory roles of phosphatidylinositol 3-kinase in IFN signaling. *J. Immunol.* 181: 7316-7323.

106. Qing, Y. and G. R. Stark. 2004. Alternative activation of STAT1 and STAT3 in response to interferon-gamma. *J. Biol. Chem.* 279: 41679-41685.

107. Becker, C., S. Wirtz, X. Ma, M. Blessing, P. R. Galle, and M. F. Neurath. 2001. Regulation of IL-12 p40 promoter activity in primary human monocytes: roles of NF-kappaB, CCAAT/enhancer-binding protein beta, and PU.1 and identification of a novel repressor element (GA-12) that responds to IL-4 and prostaglandin E(2). *J. Immunol.* 167: 2608-2618.

108. Maruyama, S., K. Sumita, H. Shen, M. Kanoh, X. Xu, M. Sato, M. Matsumoto, H. Shinomiya, and Y. Asano. 2003. Identification of IFN regulatory factor-1 binding site in IL-12 p40 gene promoter. *J. Immunol.* 170: 997-1001.

109. Carmody, R. J., Q. Ruan, H. C. Liou, and Y. H. Chen. 2007. Essential roles of c-Rel in TLR-induced IL-23 p19 gene expression in dendritic cells. *J. Immunol.* 178: 186-191.

110. Dobreva, Z. G., S. A. Stanilova, and L. D. Miteva. 2008. Differences in the inducible gene expression and protein production of IL-12p40, IL-12p70 and IL-23: involvement of p38 and JNK kinase pathways. *Cytokine* 43: 76-82.
111. Roses, R. E., S. Xu, M. Xu, U. Koldovsky, G. Koski, and B. J. Czerniecki. 2008. Differential production of IL-23 and IL-12 by myeloid-derived dendritic cells in response to TLR agonists. *J. Immunol.* 181: 5120-5127.
112. Utsugi, M., K. Dobashi, T. Ishizuka, T. Kawata, T. Hisada, Y. Shimizu, A. Ono, and M. Mori. 2006. Rac1 negatively regulates lipopolysaccharide-induced IL-23 p19 expression in human macrophages and dendritic cells and NF-kappaB p65 trans activation plays a novel role. *J. Immunol.* 177: 4550-4557.
113. Ma, X. and L. J. Montaner. 2000. Proinflammatory response and IL-12 expression in HIV-1 infection. *J. Leukoc. Biol.* 68: 383-390.
114. Hayes, M. P., J. Wang, and M. A. Norcross. 1995. Regulation of interleukin-12 expression in human monocytes: selective priming by interferon-gamma of lipopolysaccharide-inducible p35 and p40 genes. *Blood* 86: 646-650.
115. Ma, X., J. M. Chow, G. Gri, G. Carra, F. Gerosa, S. F. Wolf, R. Dzialo, and G. Trinchieri. 1996. The interleukin 12 p40 gene promoter is primed by interferon gamma in monocytic cells. *J. Exp. Med.* 183: 147-157.
116. Wang, I. M., C. Contursi, A. Masumi, X. Ma, G. Trinchieri, and K. Ozato. 2000. An IFN-gamma-inducible transcription factor, IFN consensus sequence binding protein (ICSBP), stimulates IL-12 p40 expression in macrophages. *J. Immunol.* 165: 271-279.
117. Liu, J., S. Cao, L. M. Herman, and X. Ma. 2003. Differential regulation of interleukin (IL)-12 p35 and p40 gene expression and interferon (IFN)-gamma-primed IL-12 production by IFN regulatory factor 1. *J. Exp. Med.* 198: 1265-1276.
118. Masumi, A., S. Tamaoki, I. M. Wang, K. Ozato, and K. Komuro. 2002. IRF-8/ICSBP and IRF-1 cooperatively stimulate mouse IL-12 promoter activity in macrophages. *FEBS Lett.* 531: 348-353.
119. Brown, J., H. Wang, G. N. Hajishengallis, and M. Martin. 2011. TLR-signaling networks: an integration of adaptor molecules, kinases, and cross-talk. *J. Dent. Res.* 90: 417-427.
120. Jin, M. S. and J. O. Lee. 2008. Structures of the toll-like receptor family and its ligand complexes. *Immunity* 29: 182-191.
121. Guha, M. and N. Mackman. 2001. LPS induction of gene expression in human monocytes. *Cell. Signal.* 13: 85-94.

122. Wright, S. D. 1994. Septin, an activity in plasma that enables CD14-dependent recognition of LPS. *Prog. Clin. Biol. Res.* 388: 53-57.
123. Ulevitch, R. J., J. C. Mathison, R. R. Schumann, and P. S. Tobias. 1990. A new model of macrophage stimulation by bacterial lipopolysaccharide. *J. Trauma* 30: S189-92.
124. Freudenberg, M. A., T. Merlin, M. Gumenscheimer, C. Kalis, R. Landmann, and C. Galanos. 2001. Role of lipopolysaccharide susceptibility in the innate immune response to *Salmonella typhimurium* infection: LPS, a primary target for recognition of Gram-negative bacteria. *Microbes Infect.* 3: 1213-1222.
125. Cao, Z., W. J. Henzel, and X. Gao. 1996. IRAK: a kinase associated with the interleukin-1 receptor. *Science* 271: 1128-1131.
126. Chen, Z. J. 2005. Ubiquitin signalling in the NF-kappaB pathway. *Nat. Cell Biol.* 7: 758-765.
127. Cuschieri, J. and R. V. Maier. 2005. Mitogen-activated protein kinase (MAPK). *Crit. Care Med.* 33: S417-9.
128. Liu, Y., E. G. Shepherd, and L. D. Nelin. 2007. MAPK phosphatases--regulating the immune response. *Nat. Rev. Immunol.* 7: 202-212.
129. Whitmarsh, A. J. and R. J. Davis. 1996. Transcription factor AP-1 regulation by mitogen-activated protein kinase signal transduction pathways. *J. Mol. Med. (Berl)* 74: 589-607.
130. Hazzalin, C. A. and L. C. Mahadevan. 2002. MAPK-regulated transcription: a continuously variable gene switch? *Nat. Rev. Mol. Cell Biol.* 3: 30-40.
131. Junttila, M. R., S. P. Li, and J. Westermarck. 2008. Phosphatase-mediated crosstalk between MAPK signaling pathways in the regulation of cell survival. *FASEB J.* 22: 954-965.
132. Bennett, B. L., D. T. Sasaki, B. W. Murray, E. C. O'Leary, S. T. Sakata, W. Xu, J. C. Leisten, A. Motiwala, S. Pierce, Y. Satoh, S. S. Bhagwat, A. M. Manning, and D. W. Anderson. 2001. SP600125, an anthrapyrazolone inhibitor of Jun N-terminal kinase. *Proc. Natl. Acad. Sci. U. S. A.* 98: 13681-13686.
133. Lee, J. C., S. Kumar, D. E. Griswold, D. C. Underwood, B. J. Votta, and J. L. Adams. 2000. Inhibition of p38 MAP kinase as a therapeutic strategy. *Immunopharmacology* 47: 185-201.
134. Johnson, G. L. and R. Lapadat. 2002. Mitogen-activated protein kinase pathways mediated by ERK, JNK, and p38 protein kinases. *Science* 298: 1911-1912.

135. Alessi, D. R., A. Cuenda, P. Cohen, D. T. Dudley, and A. R. Saltiel. 1995. PD 098059 is a specific inhibitor of the activation of mitogen-activated protein kinase kinase in vitro and in vivo. *J. Biol. Chem.* 270: 27489-27494.
136. Hennessy, B. T., D. L. Smith, P. T. Ram, Y. Lu, and G. B. Mills. 2005. Exploiting the PI3K/AKT pathway for cancer drug discovery. *Nat. Rev. Drug Discov.* 4: 988-1004.
137. Vlahos, C. J., W. F. Matter, K. Y. Hui, and R. F. Brown. 1994. A specific inhibitor of phosphatidylinositol 3-kinase, 2-(4-morpholinyl)-8-phenyl-4H-1-benzopyran-4-one (LY294002). *J. Biol. Chem.* 269: 5241-5248.
138. Petro, T. M. 2005. ERK-MAP-kinases differentially regulate expression of IL-23 p19 compared with p40 and IFN-beta in Theiler's virus-infected RAW264.7 cells. *Immunol. Lett.* 97: 47-53.
139. Kim, H. G., M. G. Gim, J. Y. Kim, H. J. Hwang, M. S. Ham, J. M. Lee, T. Hartung, J. W. Park, S. H. Han, and D. K. Chung. 2007. Lipoteichoic acid from *Lactobacillus plantarum* elicits both the production of interleukin-23p19 and suppression of pathogen-mediated interleukin-10 in THP-1 cells. *FEMS Immunol. Med. Microbiol.* 49: 205-214.
140. Butchar, J. P., M. V. Rajaram, L. P. Ganesan, K. V. Parsa, C. D. Clay, L. S. Schlesinger, and S. Tridandapani. 2007. *Francisella tularensis* induces IL-23 production in human monocytes. *J. Immunol.* 178: 4445-4454.
141. Mise-Omata, S., E. Kuroda, J. Niikura, U. Yamashita, Y. Obata, and T. S. Doi. 2007. A proximal kappaB site in the IL-23 p19 promoter is responsible for RelA- and c-Rel-dependent transcription. *J. Immunol.* 179: 6596-6603.
142. Liu, W., X. Ouyang, J. Yang, J. Liu, Q. Li, Y. Gu, M. Fukata, T. Lin, J. C. He, M. Abreu, J. C. Unkeless, L. Mayer, and H. Xiong. 2009. AP-1 activated by toll-like receptors regulates expression of IL-23 p19. *J. Biol. Chem.* 284: 24006-24016.
143. Gautier, G., M. Humbert, F. Deauvieau, M. Sculler, J. Hiscott, E. E. Bates, G. Trinchieri, C. Caux, and P. Garrone. 2005. A type I interferon autocrine-paracrine loop is involved in Toll-like receptor-induced interleukin-12p70 secretion by dendritic cells. *J. Exp. Med.* 201: 1435-1446.
144. Murphy, T. L., M. G. Cleveland, P. Kulesza, J. Magram, and K. M. Murphy. 1995. Regulation of interleukin 12 p40 expression through an NF-kappa B half-site. *Mol. Cell. Biol.* 15: 5258-5267.
145. Yang, C. S., J. S. Lee, S. B. Jung, J. H. Oh, C. H. Song, H. J. Kim, J. K. Park, T. H. Paik, and E. K. Jo. 2006. Differential regulation of interleukin-12 and tumour necrosis factor-alpha by phosphatidylinositol 3-kinase and ERK 1/2 pathways during *Mycobacterium tuberculosis* infection. *Clin. Exp. Immunol.* 143: 150-160.

146. Fukao, T. and S. Koyasu. 2003. PI3K and negative regulation of TLR signaling. *Trends Immunol.* 24: 358-363.
147. Schuetze, N., S. Schoeneberger, U. Mueller, M. A. Freudenberg, G. Alber, and R. K. Straubinger. 2005. IL-12 family members: differential kinetics of their TLR4-mediated induction by *Salmonella enteritidis* and the impact of IL-10 in bone marrow-derived macrophages. *Int. Immunol.* 17: 649-659.
148. Hause, L., F. M. Al-Salleh, and T. M. Petro. 2007. Expression of IL-27 p28 by Theiler's virus-infected macrophages depends on TLR3 and TLR7 activation of JNK-MAP-kinases. *Antiviral Res.* 76: 159-167.
149. Lucas, S., N. Ghilardi, J. Li, and F. J. de Sauvage. 2003. IL-27 regulates IL-12 responsiveness of naive CD4+ T cells through Stat1-dependent and -independent mechanisms. *Proc. Natl. Acad. Sci. U. S. A.* 100: 15047-15052.
150. Kamiya, S., C. Nakamura, T. Fukawa, K. Ono, T. Ohwaki, T. Yoshimoto, and S. Wada. 2007. Effects of IL-23 and IL-27 on osteoblasts and osteoclasts: inhibitory effects on osteoclast differentiation. *J. Bone Miner. Metab.* 25: 277-285.
151. Kamiya, S., T. Owaki, N. Morishima, F. Fukai, J. Mizuguchi, and T. Yoshimoto. 2004. An indispensable role for STAT1 in IL-27-induced T-bet expression but not proliferation of naive CD4+ T cells. *J. Immunol.* 173: 3871-3877.
152. Saito, F., Y. Ohno, K. Morisawa, M. Kamakura, A. Fukushima, and T. Taniguchi. 2005. Role of IL-27-producing dendritic [corrected] cells in Th1-immunity polarization in Lewis rats. *Biochem. Biophys. Res. Commun.* 338: 1773-1778.
153. Kamakura, M., K. Morisawa, H. Komi, A. Tomatani, F. Saito, Y. Konishi, Y. Jin, T. Manabe, M. Kuroda, S. Imai, H. Mizuguchi, and T. Taniguchi. 2006. Regulation of IL-27p28 gene by lipopolysaccharide in dendritic DC2.4 cells. *Biochem. Biophys. Res. Commun.* 349: 1372-1377.
154. Wirtz, S., C. Becker, M. C. Fantini, E. E. Nieuwenhuis, I. Tubbe, P. R. Galle, H. J. Schild, M. Birkenbach, R. S. Blumberg, and M. F. Neurath. 2005. EBV-induced gene 3 transcription is induced by TLR signaling in primary dendritic cells via NF-kappa B activation. *J. Immunol.* 174: 2814-2824.
155. Molle, C., M. Nguyen, V. Flamand, J. Renneson, F. Trottein, D. De Wit, F. Willems, M. Goldman, and S. Goriely. 2007. IL-27 synthesis induced by TLR ligation critically depends on IFN regulatory factor 3. *J. Immunol.* 178: 7607-7615.
156. Pirhonen, J., J. Siren, I. Julkunen, and S. Matikainen. 2007. IFN-alpha regulates Toll-like receptor-mediated IL-27 gene expression in human macrophages. *J. Leukoc. Biol.* 82: 1185-1192.

157. Schoenborn, J. R. and C. B. Wilson. 2007. Regulation of interferon-gamma during innate and adaptive immune responses. *Adv. Immunol.* 96: 41-101.
158. Hayes, M. P., J. Wang, and M. A. Norcross. 1995. Regulation of interleukin-12 expression in human monocytes: selective priming by interferon-gamma of lipopolysaccharide-inducible p35 and p40 genes. *Blood* 86: 646-650.
159. Murugaiyan, G., A. Mittal, and H. L. Weiner. 2010. Identification of an IL-27/osteopontin axis in dendritic cells and its modulation by IFN-gamma limits IL-17-mediated autoimmune inflammation. *Proc. Natl. Acad. Sci. U. S. A.* 107: 11495-11500.
160. Jurkovich, G. J., W. J. Mileski, R. V. Maier, R. K. Winn, and C. L. Rice. 1991. Interferon gamma increases sensitivity to endotoxin. *J. Surg. Res.* 51: 197-203.
161. Huang, S., W. Hendriks, A. Althage, S. Hemmi, H. Bluethmann, R. Kamijo, J. Vilcek, R. M. Zinkernagel, and M. Aguet. 1993. Immune response in mice that lack the interferon-gamma receptor. *Science* 259: 1742-1745.
162. Kamijo, R., J. Le, D. Shapiro, E. A. Havell, S. Huang, M. Aguet, M. Bosland, and J. Vilcek. 1993. Mice that lack the interferon-gamma receptor have profoundly altered responses to infection with *Bacillus Calmette-Guerin* and subsequent challenge with lipopolysaccharide. *J. Exp. Med.* 178: 1435-1440.
163. Vadiveloo, P. K., G. Vairo, P. Hertzog, I. Kola, and J. A. Hamilton. 2000. Role of type I interferons during macrophage activation by lipopolysaccharide. *Cytokine* 12: 1639-1646.
164. Williams, J. G., G. J. Jurkovich, G. B. Hahnel, and R. V. Maier. 1992. Macrophage priming by interferon gamma: a selective process with potentially harmful effects. *J. Leukoc. Biol.* 52: 579-584.
165. Car, B. D., V. M. Eng, B. Schnyder, L. Ozmen, S. Huang, P. Gally, D. Heumann, M. Aguet, and B. Ryffel. 1994. Interferon gamma receptor deficient mice are resistant to endotoxic shock. *J. Exp. Med.* 179: 1437-1444.
166. Schroder, K., M. J. Sweet, and D. A. Hume. 2006. Signal integration between IFN-gamma and TLR signalling pathways in macrophages. *Immunobiology* 211: 511-524.
167. Bosisio, D., N. Polentarutti, M. Sironi, S. Bernasconi, K. Miyake, G. R. Webb, M. U. Martin, A. Mantovani, and M. Muzio. 2002. Stimulation of toll-like receptor 4 expression in human mononuclear phagocytes by interferon-gamma: a molecular basis for priming and synergism with bacterial lipopolysaccharide. *Blood* 99: 3427-3431.
168. Mita, Y., K. Dobashi, K. Endou, T. Kawata, Y. Shimizu, T. Nakazawa, and M. Mori. 2002. Toll-like receptor 4 surface expression on human monocytes and B cells is modulated by IL-2 and IL-4. *Immunol. Lett.* 81: 71-75.

169. Darmani, H., J. Parton, J. L. Harwood, and S. K. Jackson. 1994. Interferon-gamma and polyunsaturated fatty acids increase the binding of lipopolysaccharide to macrophages. *Int. J. Exp. Pathol.* 75: 363-368.
170. Adib-Conquy, M. and J. M. Cavaillon. 2002. Gamma interferon and granulocyte/monocyte colony-stimulating factor prevent endotoxin tolerance in human monocytes by promoting interleukin-1 receptor-associated kinase expression and its association to MyD88 and not by modulating TLR4 expression. *J. Biol. Chem.* 277: 27927-27934.
171. de Wit, H., D. Hoogstraten, R. M. Halie, and E. Vellenga. 1996. Interferon-gamma modulates the lipopolysaccharide-induced expression of AP-1 and NF-kappa B at the mRNA and protein level in human monocytes. *Exp. Hematol.* 24: 228-235.
172. Drapier, J. C., J. Wietzerbin, and J. B. Hibbs Jr. 1988. Interferon-gamma and tumor necrosis factor induce the L-arginine-dependent cytotoxic effector mechanism in murine macrophages. *Eur. J. Immunol.* 18: 1587-1592.
173. Huang, Y., P. M. Krein, D. A. Muruve, and B. W. Winston. 2002. Complement factor B gene regulation: synergistic effects of TNF-alpha and IFN-gamma in macrophages. *J. Immunol.* 169: 2627-2635.
174. Kovarik, P., D. Stoiber, M. Novy, and T. Decker. 1998. Stat1 combines signals derived from IFN-gamma and LPS receptors during macrophage activation. *EMBO J.* 17: 3660-3668.
175. Cramer, L. A., S. L. Nelson, and M. J. Klemsz. 2000. Synergistic induction of the Tap-1 gene by IFN-gamma and lipopolysaccharide in macrophages is regulated by STAT1. *J. Immunol.* 165: 3190-3197.
176. Kovarik, P., D. Stoiber, P. A. Eyers, R. Menghini, A. Neininger, M. Gaestel, P. Cohen, and T. Decker. 1999. Stress-induced phosphorylation of STAT1 at Ser727 requires p38 mitogen-activated protein kinase whereas IFN-gamma uses a different signaling pathway. *Proc. Natl. Acad. Sci. U. S. A.* 96: 13956-13961.
177. Sims, S. H., Y. Cha, M. F. Romine, P. Q. Gao, K. Gottlieb, and A. B. Deisseroth. 1993. A novel interferon-inducible domain: structural and functional analysis of the human interferon regulatory factor 1 gene promoter. *Mol. Cell. Biol.* 13: 690-702.
178. Pine, R. 1997. Convergence of TNFalpha and IFNgamma signalling pathways through synergistic induction of IRF-1/ISGF-2 is mediated by a composite GAS/kappaB promoter element. *Nucleic Acids Res.* 25: 4346-4354.
179. Guha, M. and N. Mackman. 2002. The phosphatidylinositol 3-kinase-Akt pathway limits lipopolysaccharide activation of signaling pathways and expression of inflammatory mediators in human monocytic cells. *J. Biol. Chem.* 277: 32124-32132.

180. Aksamitiene, E., A. Kiyatkin, and B. N. Kholodenko. 2012. Cross-talk between mitogenic Ras/MAPK and survival PI3K/Akt pathways: a fine balance. *Biochem. Soc. Trans.* 40: 139-146.
181. Thomas, M. and C. Owen. 2008. Inhibition of PI-3 kinase for treating respiratory disease: good idea or bad idea? *Curr. Opin. Pharmacol.* 8: 267-274.
182. Arbibe, L., J. P. Mira, N. Teusch, L. Kline, M. Guha, N. Mackman, P. J. Godowski, R. J. Ulevitch, and U. G. Knaus. 2000. Toll-like receptor 2-mediated NF-kappa B activation requires a Rac1-dependent pathway. *Nat. Immunol.* 1: 533-540.
183. Madrid, L. V., M. W. Mayo, J. Y. Reuther, and A. S. Baldwin Jr. 2001. Akt stimulates the transactivation potential of the RelA/p65 Subunit of NF-kappa B through utilization of the Ikappa B kinase and activation of the mitogen-activated protein kinase p38. *J. Biol. Chem.* 276: 18934-18940.
184. Shan, X., A. Hu, H. Veler, S. Fatma, J. S. Grunstein, S. Chuang, and M. M. Grunstein. 2006. Regulation of Toll-like receptor 4-induced proasthmatic changes in airway smooth muscle function by opposing actions of ERK1/2 and p38 MAPK signaling. *Am. J. Physiol. Lung Cell. Mol. Physiol.* 291: L324-33.
185. Heinrichsdorff, J., T. Luedde, E. Perdiguero, A. R. Nebreda, and M. Pasparakis. 2008. p38 alpha MAPK inhibits JNK activation and collaborates with IkappaB kinase 2 to prevent endotoxin-induced liver failure. *EMBO Rep.* 9: 1048-1054.
186. Saxena, M., A. Busca, S. Pandey, M. Kryworuchko, and A. Kumar. 2011. CpG protects human monocytic cells against HIV-Vpr-induced apoptosis by cellular inhibitor of apoptosis-2 through the calcium-activated JNK pathway in a TLR9-independent manner. *J. Immunol.* 187: 5865-5878.
187. Sheikh, S. Z., K. Matsuoka, T. Kobayashi, F. Li, T. Rubinas, and S. E. Plevy. 2010. Cutting edge: IFN-gamma is a negative regulator of IL-23 in murine macrophages and experimental colitis. *J. Immunol.* 184: 4069-4073.
188. Gee, K., M. Kozlowski, M. Kryworuchko, F. Diaz-Mitoma, and A. Kumar. 2001. Differential effect of IL-4 and IL-13 on CD44 expression in the Burkitt's lymphoma B cell line BL30/B95-8 and in Epstein-Barr virus (EBV) transformed human B cells: loss of IL-13 receptors on Burkitt's lymphoma B cells. *Cell. Immunol.* 211: 131-142.
189. Ma, W., S. Mishra, K. Gee, J. P. Mishra, D. Nandan, N. E. Reiner, J. B. Angel, and A. Kumar. 2007. Cyclosporin A and FK506 inhibit IL-12p40 production through the calmodulin/calmodulin-dependent protein kinase-activated phosphoinositide 3-kinase in lipopolysaccharide-stimulated human monocytic cells. *J. Biol. Chem.* 282: 13351-13362.
190. Guha, M., M. A. O'Connell, R. Pawlinski, A. Hollis, P. McGovern, S. F. Yan, D. Stern, and N. Mackman. 2001. Lipopolysaccharide activation of the MEK-ERK1/2 pathway in

human monocytic cells mediates tissue factor and tumor necrosis factor alpha expression by inducing Elk-1 phosphorylation and Egr-1 expression. *Blood* 98: 1429-1439.

191. Garrett, S., M. C. Fitzgerald, and K. E. Sullivan. 2008. LPS and poly I:C induce chromatin modifications at a novel upstream region of the IL-23 p19 promoter. *Inflammation* 31: 235-246.

192. Liu, J., X. Guan, and X. Ma. 2007. Regulation of IL-27 p28 gene expression in macrophages through MyD88- and interferon-gamma-mediated pathways. *J. Exp. Med.* 204: 141-152.

193. Goodridge, H. S., W. Harnett, F. Y. Liew, and M. M. Harnett. 2003. Differential regulation of interleukin-12 p40 and p35 induction via Erk mitogen-activated protein kinase-dependent and -independent mechanisms and the implications for bioactive IL-12 and IL-23 responses. *Immunology* 109: 415-425.

194. Theus, S. A., M. D. Cave, and K. D. Eisenach. 2004. Activated THP-1 cells: an attractive model for the assessment of intracellular growth rates of *Mycobacterium tuberculosis* isolates. *Infect. Immun.* 72: 1169-1173.

195. Ma, X. T., X. J. Zhang, B. Zhang, Y. Q. Geng, Y. M. Lin, G. Li, and K. F. Wu. 2004. Expression and regulation of interleukin-23 subunits in human peripheral blood mononuclear cells and hematopoietic cell lines in response to various inducers. *Cell Biol. Int.* 28: 689-697.

196. Uchijima, M., T. Nagata, T. Aoshi, and Y. Koide. 2005. IFN-gamma overcomes low responsiveness of myeloid dendritic cells to CpG DNA. *Immunol. Cell Biol.* 83: 92-95.

197. Vignali, D. A. and V. K. Kuchroo. 2012. IL-12 family cytokines: immunological playmakers. *Nat. Immunol.* 13: 722-728.

198. Hibbert, L., S. Pflanz, R. De Waal Malefyt, and R. A. Kastelein. 2003. IL-27 and IFN-alpha signal via Stat1 and Stat3 and induce T-Bet and IL-12Rbeta2 in naive T cells. *J. Interferon Cytokine Res.* 23: 513-522.

199. Horvath, C. M. 2004. The Jak-STAT pathway stimulated by interferon gamma. *Sci. STKE* 2004: tr8.

200. Palsson-McDermott, E. M. and L. A. O'Neill. 2004. Signal transduction by the lipopolysaccharide receptor, Toll-like receptor-4. *Immunology* 113: 153-162.

201. Verschooten, L., K. Barrette, S. Van Kelst, N. Rubio Romero, C. Proby, R. De Vos, P. Agostinis, and M. Garmyn. 2012. Autophagy inhibitor chloroquine enhanced the cell death inducing effect of the flavonoid luteolin in metastatic squamous cell carcinoma cells. *PLoS One* 7: e48264.

202. Blackshear, P. J. 2002. Tristetraprolin and other CCCH tandem zinc-finger proteins in the regulation of mRNA turnover. *Biochem. Soc. Trans.* 30: 945-952.
203. Qian, X., H. Ning, J. Zhang, D. F. Hoft, D. J. Stumpo, P. J. Blackshear, and J. Liu. 2011. Posttranscriptional regulation of IL-23 expression by IFN-gamma through tristetraprolin. *J. Immunol.* 186: 6454-6464.
204. Taga, T. 1997. The signal transducer gp130 is shared by interleukin-6 family of haematopoietic and neurotrophic cytokines. *Ann. Med.* 29: 63-72.
205. Jackson, A. M., L. A. Mulcahy, J. Porte, H. A. Franks, M. El Refaee, Q. Wang, S. Shah, X. Zhu, and P. M. Patel. 2010. Role of mitogen-activated protein kinase and PI3K pathways in the regulation of IL-12-family cytokines in dendritic cells and the generation of T H-responses. *Eur. Cytokine Netw.* 21: 319-328.
206. Kryczek, I., S. Wei, W. Gong, X. Shu, W. Szeliga, L. Vatan, L. Chen, G. Wang, and W. Zou. 2008. Cutting edge: IFN-gamma enables APC to promote memory Th17 and abate Th1 cell development. *J. Immunol.* 181: 5842-5846.
207. Landmann, R., S. Link, S. Sansano, Z. Rajacic, and W. Zimmerli. 1998. Soluble CD14 activates monocytic cells independently of lipopolysaccharide. *Infect. Immun.* 66: 2264-2271.
208. Elkord, E., P. E. Williams, H. Kynaston, and A. W. Rowbottom. 2005. Human monocyte isolation methods influence cytokine production from in vitro generated dendritic cells. *Immunology* 114: 204-212.
209. Faries, M. B., I. Bedrosian, S. Xu, G. Koski, J. G. Roros, M. A. Moise, H. Q. Nguyen, F. H. Engels, P. A. Cohen, and B. J. Czerniecki. 2001. Calcium signaling inhibits interleukin-12 production and activates CD83(+) dendritic cells that induce Th2 cell development. *Blood* 98: 2489-2497.
210. Hanada, T., K. Tanaka, Y. Matsumura, M. Yamauchi, H. Nishinakamura, H. Aburatani, R. Mashima, M. Kubo, T. Kobayashi, and A. Yoshimura. 2005. Induction of hyper Th1 cell-type immune responses by dendritic cells lacking the suppressor of cytokine signaling-1 gene. *J. Immunol.* 174: 4325-4332.
211. Li, Y., N. Chu, A. Hu, B. Gran, A. Rostami, and G. X. Zhang. 2008. Inducible IL-23p19 expression in human microglia via p38 MAPK and NF-kappaB signal pathways. *Exp. Mol. Pathol.* 84: 1-8.
212. Sun, D. and A. Ding. 2006. MyD88-mediated stabilization of interferon-gamma-induced cytokine and chemokine mRNA. *Nat. Immunol.* 7: 375-381.
213. Harada, H., E. Takahashi, S. Itoh, K. Harada, T. A. Hori, and T. Taniguchi. 1994. Structure and regulation of the human interferon regulatory factor 1 (IRF-1) and IRF-2

genes: implications for a gene network in the interferon system. *Mol. Cell. Biol.* 14: 1500-1509.

214. Eichbaum, Q. G., R. Iyer, D. P. Raveh, C. Mathieu, and R. A. Ezekowitz. 1994. Restriction of interferon gamma responsiveness and basal expression of the myeloid human Fc gamma R1b gene is mediated by a functional PU.1 site and a transcription initiator consensus. *J. Exp. Med.* 179: 1985-1996.

215. Hu, J., S. K. Roy, P. S. Shapiro, S. R. Rodig, S. P. Reddy, L. C. Platanias, R. D. Schreiber, and D. V. Kalvakolanu. 2001. ERK1 and ERK2 activate CCAAAT/enhancer-binding protein-beta-dependent gene transcription in response to interferon-gamma. *J. Biol. Chem.* 276: 287-297.

216. Ramana, C. V., M. P. Gil, R. D. Schreiber, and G. R. Stark. 2002. Stat1-dependent and -independent pathways in IFN-gamma-dependent signaling. *Trends Immunol.* 23: 96-101.

217. Deb, A., S. J. Haque, T. Mogensen, R. H. Silverman, and B. R. Williams. 2001. RNA-dependent protein kinase PKR is required for activation of NF-kappa B by IFN-gamma in a STAT1-independent pathway. *J. Immunol.* 166: 6170-6180.

218. Mahtani, K. R., M. Brook, J. L. Dean, G. Sully, J. Saklatvala, and A. R. Clark. 2001. Mitogen-activated protein kinase p38 controls the expression and posttranslational modification of tristetraprolin, a regulator of tumor necrosis factor alpha mRNA stability. *Mol. Cell. Biol.* 21: 6461-6469.

219. Rutault, K., C. A. Hazzalin, and L. C. Mahadevan. 2001. Combinations of ERK and p38 MAPK inhibitors ablate tumor necrosis factor-alpha (TNF-alpha) mRNA induction. Evidence for selective destabilization of TNF-alpha transcripts. *J. Biol. Chem.* 276: 6666-6674.

220. Larsen, J. M., C. M. Bonefeld, S. S. Poulsen, C. Geisler, and L. Skov. 2009. IL-23 and T(H)17-mediated inflammation in human allergic contact dermatitis. *J. Allergy Clin. Immunol.* 123: 486-492.

221. Stewart, C. A. and G. Trinchieri. 2009. Reinforcing suppression using regulators: a new link between STAT3, IL-23, and Tregs in tumor immunosuppression. *Cancer. Cell.* 15: 81-83.

222. Kohyama, S., S. Ohno, A. Isoda, O. Moriya, M. L. Belladonna, H. Hayashi, Y. Iwakura, T. Yoshimoto, T. Akatsuka, and M. Matsui. 2007. IL-23 enhances host defense against vaccinia virus infection via a mechanism partly involving IL-17. *J. Immunol.* 179: 3917-3925.

223. Kumar, S., P. C. McDonnell, R. J. Gum, A. T. Hand, J. C. Lee, and P. R. Young. 1997. Novel homologues of CSBP/p38 MAP kinase: activation, substrate specificity and sensitivity to inhibition by pyridinyl imidazoles. *Biochem. Biophys. Res. Commun.* 235: 533-538.

224. Cuenda, A. and S. Rousseau. 2007. p38 MAP-kinases pathway regulation, function and role in human diseases. *Biochim. Biophys. Acta* 1773: 1358-1375.
225. Lu, G., Y. J. Kang, J. Han, H. R. Herschman, E. Stefani, and Y. Wang. 2006. TAB-1 modulates intracellular localization of p38 MAP kinase and downstream signaling. *J. Biol. Chem.* 281: 6087-6095.
226. Murphy, T. L., M. G. Cleveland, P. Kulesza, J. Magram, and K. M. Murphy. 1995. Regulation of interleukin 12 p40 expression through an NF-kappa B half-site. *Mol. Cell. Biol.* 15: 5258-5267.
227. Li, J. J., W. Wang, K. J. Baines, N. A. Bowden, P. M. Hansbro, P. G. Gibson, R. K. Kumar, P. S. Foster, and M. Yang. 2010. IL-27/IFN-gamma induce MyD88-dependent steroid-resistant airway hyperresponsiveness by inhibiting glucocorticoid signaling in macrophages. *J. Immunol.* 185: 4401-4409.
228. Ramana, C. V., A. Kumar, and R. Enelow. 2005. Stat1-independent induction of SOCS-3 by interferon-gamma is mediated by sustained activation of Stat3 in mouse embryonic fibroblasts. *Biochem. Biophys. Res. Commun.* 327: 727-733.
229. Meinke, A., F. Barahmand-Pour, S. Wohrl, D. Stoiber, and T. Decker. 1996. Activation of different Stat5 isoforms contributes to cell-type-restricted signaling in response to interferons. *Mol. Cell. Biol.* 16: 6937-6944.
230. Remoli, M. E., V. Gafa, E. Giacomini, M. Severa, R. Lande, and E. M. Coccia. 2007. IFN-beta modulates the response to TLR stimulation in human DC: involvement of IFN regulatory factor-1 (IRF-1) in IL-27 gene expression. *Eur. J. Immunol.* 37: 3499-3508.
231. Brentano, F., C. Ospelt, J. Stanczyk, R. E. Gay, S. Gay, and D. Kyburz. 2009. Abundant expression of the interleukin (IL)23 subunit p19, but low levels of bioactive IL23 in the rheumatoid synovium: differential expression and Toll-like receptor-(TLR) dependent regulation of the IL23 subunits, p19 and p40, in rheumatoid arthritis. *Ann. Rheum. Dis.* 68: 143-150.
232. Johnson, G. L. and K. Nakamura. 2007. The c-jun kinase/stress-activated pathway: regulation, function and role in human disease. *Biochim. Biophys. Acta* 1773: 1341-1348.
233. Lai, W. S., E. Carballo, J. M. Thorn, E. A. Kennington, and P. J. Blakeshear. 2000. Interactions of CCCH zinc finger proteins with mRNA. Binding of tristetraprolin-related zinc finger proteins to Au-rich elements and destabilization of mRNA. *J. Biol. Chem.* 275: 17827-17837.
234. Stoecklin, G., M. Colombi, I. Raineri, S. Leuenberger, M. Mallaun, M. Schmidlin, B. Gross, M. Lu, T. Kitamura, and C. Moroni. 2002. Functional cloning of BRF1, a regulator of ARE-dependent mRNA turnover. *EMBO J.* 21: 4709-4718.

235. Qian, X., H. Ning, J. Zhang, D. F. Hoft, D. J. Stumpo, P. J. Blakeshear, and J. Liu. 2011. Posttranscriptional regulation of IL-23 expression by IFN-gamma through tristetraprolin. *J. Immunol.* 186: 6454-6464.
236. Pflanz, S., L. Hibbert, J. Mattson, R. Rosales, E. Vaisberg, J. F. Bazan, J. H. Phillips, T. K. McClanahan, R. de Waal Malefyt, and R. A. Kastelein. 2004. WSX-1 and glycoprotein 130 constitute a signal-transducing receptor for IL-27. *J. Immunol.* 172: 2225-2231.
237. Bette, M., S. C. Jin, T. Germann, M. K. Schafer, E. Weihe, E. Rude, and B. Fleischer. 1994. Differential expression of mRNA encoding interleukin-12 p35 and p40 subunits in situ. *Eur. J. Immunol.* 24: 2435-2440.
238. D'Andrea, A., M. Rengaraju, N. M. Valiante, J. Chehimi, M. Kubin, M. Aste, S. H. Chan, M. Kobayashi, D. Young, and E. Nickbarg. 1992. Production of natural killer cell stimulatory factor (interleukin 12) by peripheral blood mononuclear cells. *J. Exp. Med.* 176: 1387-1398.
239. Snijders, A., C. M. Hilkens, T. C. van der Pouw Kraan, M. Engel, L. A. Aarden, and M. L. Kapsenberg. 1996. Regulation of bioactive IL-12 production in lipopolysaccharide-stimulated human monocytes is determined by the expression of the p35 subunit. *J. Immunol.* 156: 1207-1212.
240. Fan, X., V. Sibalic, E. Niederer, and R. P. Wuthrich. 1996. The proinflammatory cytokine interleukin-12 occurs as a cell membrane-bound form on macrophages. *Biochem. Biophys. Res. Commun.* 225: 1063-1067.
241. Quinones, M., S. K. Ahuja, P. C. Melby, L. Pate, R. L. Reddick, and S. S. Ahuja. 2000. Preformed membrane-associated stores of interleukin (IL)-12 are a previously unrecognized source of bioactive IL-12 that is mobilized within minutes of contact with an intracellular parasite. *J. Exp. Med.* 192: 507-516.
242. Vaidyanathan, H., Y. Zhou, T. M. Petro, and S. D. Schwartzbach. 2003. Intracellular localization of the p35 subunit of murine IL-12. *Cytokine* 21: 120-128.
243. Goodall, J. C., C. Wu, Y. Zhang, L. McNeill, L. Ellis, V. Saudek, and J. S. Gaston. 2010. Endoplasmic reticulum stress-induced transcription factor, CHOP, is crucial for dendritic cell IL-23 expression. *Proc. Natl. Acad. Sci. U. S. A.* 107: 17698-17703.