

## INFORMATION TO USERS

This manuscript has been reproduced from the microfilm master. UMI films the text directly from the original or copy submitted. Thus, some thesis and dissertation copies are in typewriter face, while others may be from any type of computer printer.

**The quality of this reproduction is dependent upon the quality of the copy submitted.** Broken or indistinct print, colored or poor quality illustrations and photographs, print bleedthrough, substandard margins, and improper alignment can adversely affect reproduction.

In the unlikely event that the author did not send UMI a complete manuscript and there are missing pages, these will be noted. Also, if unauthorized copyright material had to be removed, a note will indicate the deletion.

Oversize materials (e.g., maps, drawings, charts) are reproduced by sectioning the original, beginning at the upper left-hand corner and continuing from left to right in equal sections with small overlaps.

ProQuest Information and Learning  
300 North Zeeb Road, Ann Arbor, MI 48106-1346 USA  
800-521-0600

UMI<sup>®</sup>

Vertical line of text on the left margin, possibly a page number or header.

Vertical line of text on the right margin, possibly a page number or header.

A HYBRID CHANNEL ASSIGNMENT SCHEME  
IN  
CELLULAR-STRUCTURED MOBILE COMMUNICATIONS NETWORKS

BY

TOMSON JOE KAHWA

Submitted to the School of Graduate Studies  
in partial fulfillment of the  
requirements for the degree of

MASTER OF APPLIED SCIENCE

Department of Electrical Engineering  
Faculty of Science and Engineering  
University of Ottawa

Ottawa, Ontario

May 1977



© Tomson Joe Kahwa, Ottawa, Canada, 1977

UMI Number: EC52261

### INFORMATION TO USERS

The quality of this reproduction is dependent upon the quality of the copy submitted. Broken or indistinct print, colored or poor quality illustrations and photographs, print bleed-through, substandard margins, and improper alignment can adversely affect reproduction.

In the unlikely event that the author did not send a complete manuscript and there are missing pages, these will be noted. Also, if unauthorized copyright material had to be removed, a note will indicate the deletion.

**UMI<sup>®</sup>**

---

UMI Microform EC52261  
Copyright 2007 by ProQuest LLC  
All rights reserved. This microform edition is protected against  
unauthorized copying under Title 17, United States Code.

---

ProQuest LLC  
789 East Eisenhower Parkway  
P.O. Box 1346  
Ann Arbor, MI 48106-1346

A B S T R A C T

The simultaneous use of fixed and dynamic channel assignment schemes, in the same cellular structured mobile communications network, is called a hybrid channel assignment scheme. Detailed performance evaluations of the fixed vs. the dynamic channel assignment schemes have been published by various authors.

In this thesis, the performance of the hybrid channel assignment scheme, under various loading conditions is studied, by using simulation results of a cellular mobile communications system that has forty cells. A conclusion is reached as to when it is best to use hybrid or fixed channel assignment schemes.

## ACKNOWLEDGEMENT

I wish to thank Dr. N. Georganas, my thesis supervisor, for his comments, criticisms, and his invaluable guidance throughout the entire period of this research.

I would also like to express my deepest appreciations to those who have contributed directly and indirectly to the task of producing this thesis. In particular, I would like to acknowledge the assistance received from Mr. Le Henaff, Administrative Officer of the Department of Electrical Engineering, University of Ottawa and the staff at the Computing Centre, University of Ottawa.

The financial assistance provided by an NRC Operating Grant is also gratefully acknowledged.

My final and substantial debt is to Henne, my wife, who painstakingly typed my thesis and cheerfully excused me from other obligations so as to make the necessary time available to complete this work.

TABLE OF CONTENTS

	<u>PAGE</u>
Abstract	i
Acknowledgements	ii
<u>CHAPTER 1</u> INTRODUCTION . . . . .	1
<u>CHAPTER 2</u> THE CHANNEL ASSIGNMENT PROBLEM	
2.1. Introduction . . . . .	5
2.2. Basic Channel Assignment Schemes . . . . .	13
2.3. Problem Statement . . . . .	14
2.4. Present Literature . . . . .	14
2.4.1. Fixed vs. Dynamic Channel Assignment Scheme .	18
2.4.2. Constrained Dynamic Channel Assignment Scheme.	21
<u>CHAPTER 3</u> HYBRID CHANNEL ASSIGNMENT	
3.1. Introduction . . . . .	23
3.2. Steps Followed in the Hybrid Channel Assignment Scheme's Simulations and Evaluations . . . . .	27
3.3. Description of Simulated Systems . . . . .	29
<u>CHAPTER 4</u> GPSS SIMULATION RESULTS . . . . .	31
<u>CHAPTER 5</u> CONCLUSIONS . . . . .	42

TABLE OF CONTENTS (Cont'd)

	<u>PAGE</u>
REFERENCES . . . . .	44
APPENDICES	
A. The General Purpose Simulation System .	
B. Flow Charts of GPSS . . . . .	
C. Computer Programmes . . . . .	
VITAE . . . . .	

# C H A P T E R 1

## INTRODUCTION

The last two decades have seen enormous increases in demand for mobile communication services, especially in urban areas (10, 23, 29). From available forecast studies, this rate of increase will continue for quite some time.

In order to plan for this expected increase and simultaneously solve the present crisis of channel shortage for mobile radio use, some improvements to existing systems have been suggested. One of the most favoured and commonly discussed techniques for increasing the efficiency of frequency spectrum utilization is the adoption of a cellular structure. With the cellular structure approach, the urban area is divided into cells or zones and each cell is given its own base station for communication with vehicles in its cell. In this system, each mobile user is connected to the Mobile Switching Office (MSO) via land facilities, and the MSO is in turn connected to all the base stations. See Fig. 1.1. The communications path is from non-mobile user to MSO to mobile user. Because each base station transmits over a local area, it is possible to re-use the same frequency simultaneously in other cells in the city. This kind of system has obvious advantages for mobile users.

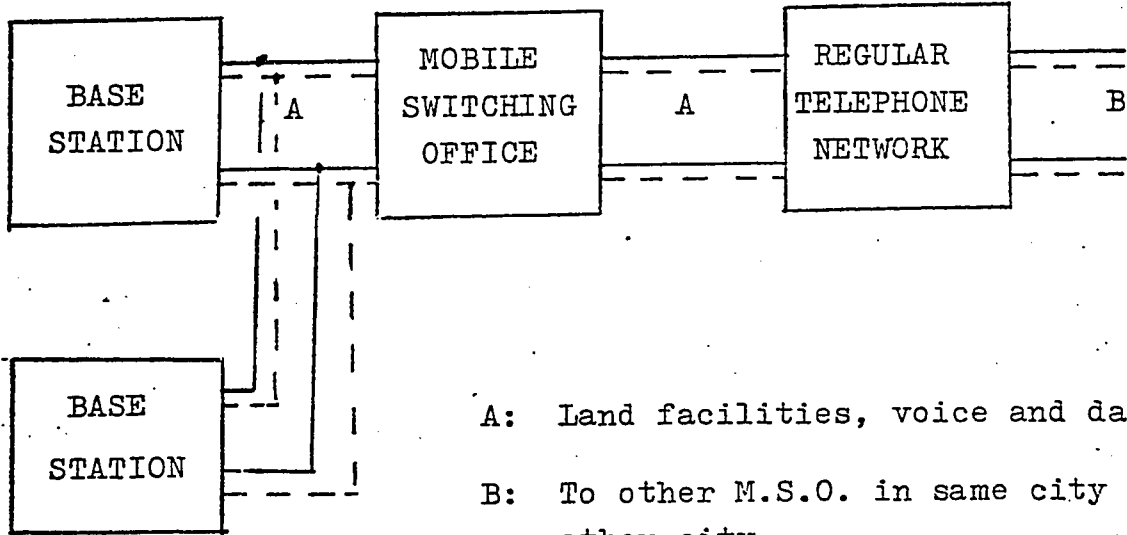

A: Land facilities, voice and data

B: To other M.S.O. in same city or other city.

M.S.O. contains switching machine and system controller.

FIG. 1.1  
BLOCK DIAGRAM OF MOBILE COMMUNICATION SYSTEM LAYOUT

Some of these advantages are:

1. Automatic gathering of user message statistics should result in lower cost rates,
2. Transceivers will be given unique identity numbers so that they can be paged while anywhere in this system. Since the transceiver will be expected to be able to operate in any frequency assigned to it by the base station, monitoring somebody else's messages will be almost impossible.

What we have concerned ourselves with in this thesis is the problem of channel assignment techniques to the cells. In Chapter 2, Section 2.1., we have introduced the general concept of mobile cellular arrangement and how it is expected to be implemented. In Section 2.2, we have discussed some of the basic channel assignment schemes and in the remainder of Chapter 2, we have presented a brief summary of the present literature on this subject.

In Chapter 3, we have introduced and discussed a particular type of channel assignment scheme, called the Hybrid Channel Assignment. The main work for this thesis is concerned with this scheme. We have simulated a forty cell mobile communications system that employs the hybrid channel assignment scheme. We used IBM's General Purpose Simulation System (GPSS/360) simulation language. The simulation

results are presented in Chapter 4 and Chapter 5 contains the conclusions. We have included in the Appendices a description of GPSS/360, flow charts of GPSS and a computer programme that was used for the simulations.

## C H A P T E R 2

### THE CHANNEL ASSIGNMENT PROBLEM

#### 2.1 INTRODUCTION

Some of the existing and earlier mobile radio telephone networks were designed along the concept of 'global coverage' (2). In this arrangement, one powerful transmitter, usually centrally located, would give service on all available radio channels to the entire service area. This approach to system design was quite satisfactory because, among other reasons, (a) the frequencies in the low band (27.23 - 50 MHz) and the high band (138-174 MHz) could afford wide area coverage without serious signal attenuation, and (b) the demand for service could be served with the number of channels allocated.

Because of increased service demand, cellular structured systems are being designed to replace 'global systems', and in so doing, increase the channel occupancy. (See figures 2.1 and 2.2)

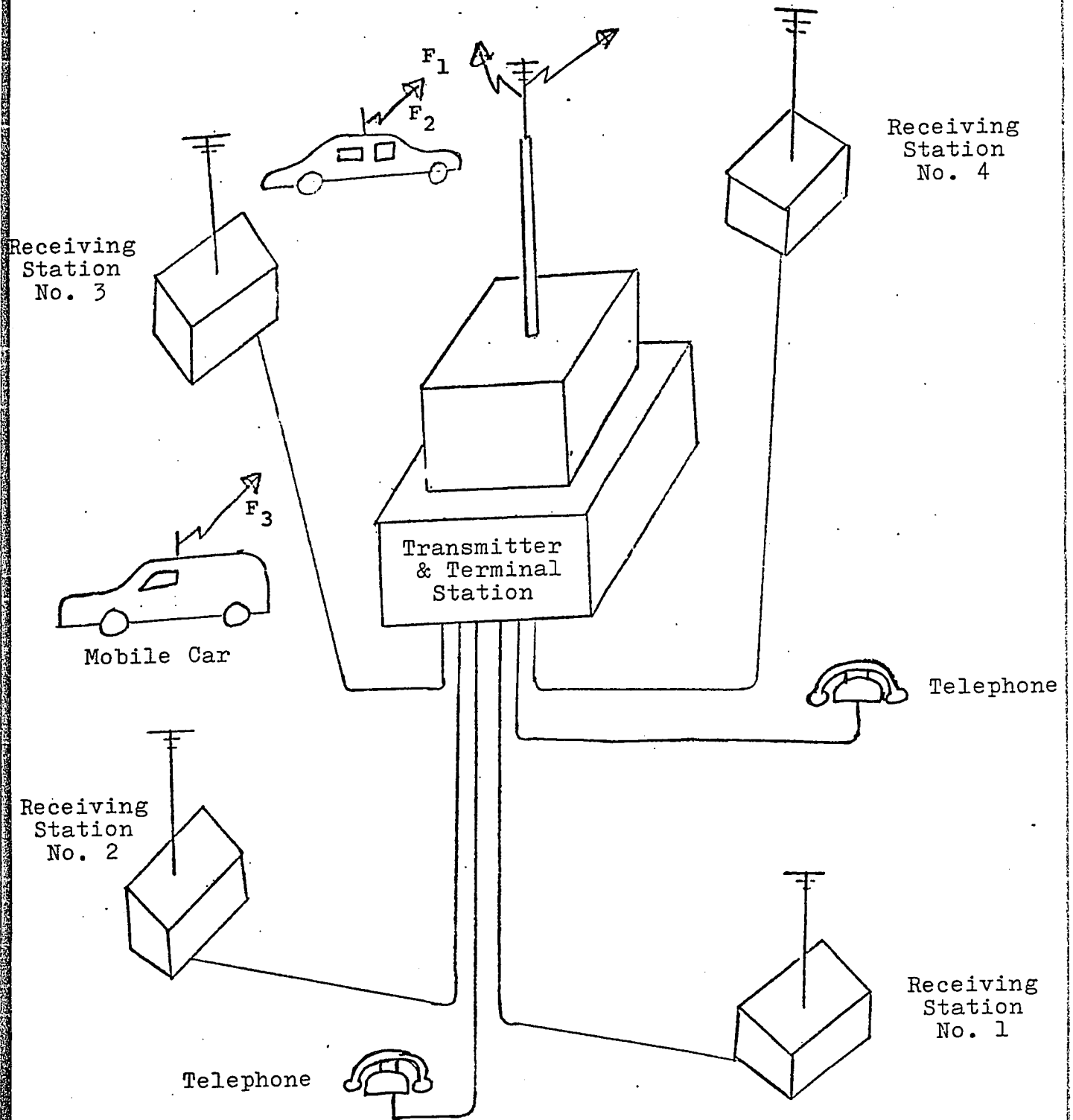
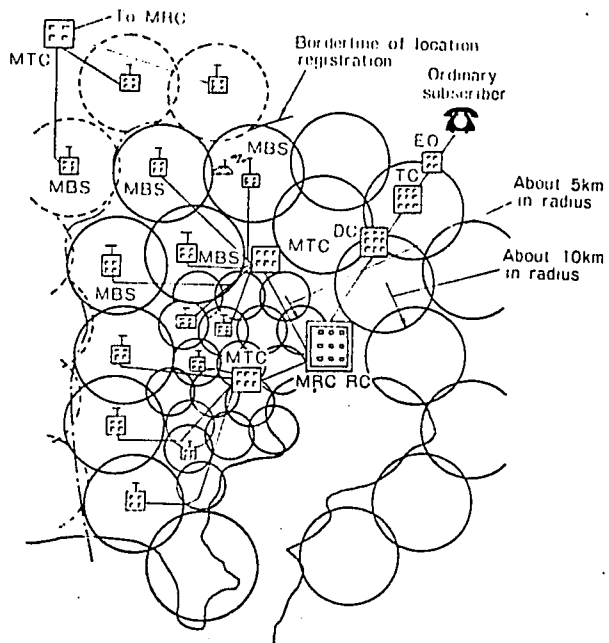

FIG. 2.1. A GENERAL MOBILE RADIO NETWORK: GLOBAL NETWORK



MSS: Mobile Subscriber Station  
MBS: Mobile Base Station  
MTC: Mobile Toll Center  
MRC: Mobile Regional Center

RC	: Ordinary telephone network
DC	
TC	
EO	

Circle: Mobile base station service area  
Large circle: Suburban area  
Small circle: Urban area (building streets)

Fig. 2.2. . . Land Mobile Radio Telephone System zone structure and a network structure model  
(Diagram taken from Ref. 17)

An increased conceptual interpretation of the cellular mobile radio-communications system is given by Fig. 2.3. The properties or attributes that help characterize the cellular systems will now be explained, with the aid of Figures 2.3 and 2.4.

For this explanation, there is one assumption made, namely, that the power level of a signal radiated from a cell's base station, (Fig. 2-3) is sufficient to give an adequate signal-to-noise ratio at that cell's boundary, and a little beyond. Therefore, the coverage limitation is due to interference, mainly co-channel interference and, to a less extent, intermodulation interference, and not due to lack of sufficient signal power or presence of excessive thermal noise. The letters in the cells (Fig. 2.3) represent sets of channels assigned for use within the cell. We associate with every channel, from a channel set, a nominal cell or nominal cells, meaning any cell or cells, where channel set A is assigned for use. Conversely, for every cell, we speak of its nominal channels, which are the channels assigned for use in that cell. The shaded cell in Fig. 2.3 has nominal channels that are contained in set  $A^1$ . The highest superscript on a channel set serves to indicate how many times that channel set has been re-used.  $A^i$  and  $B^j$  means that set A is being assigned for use to a

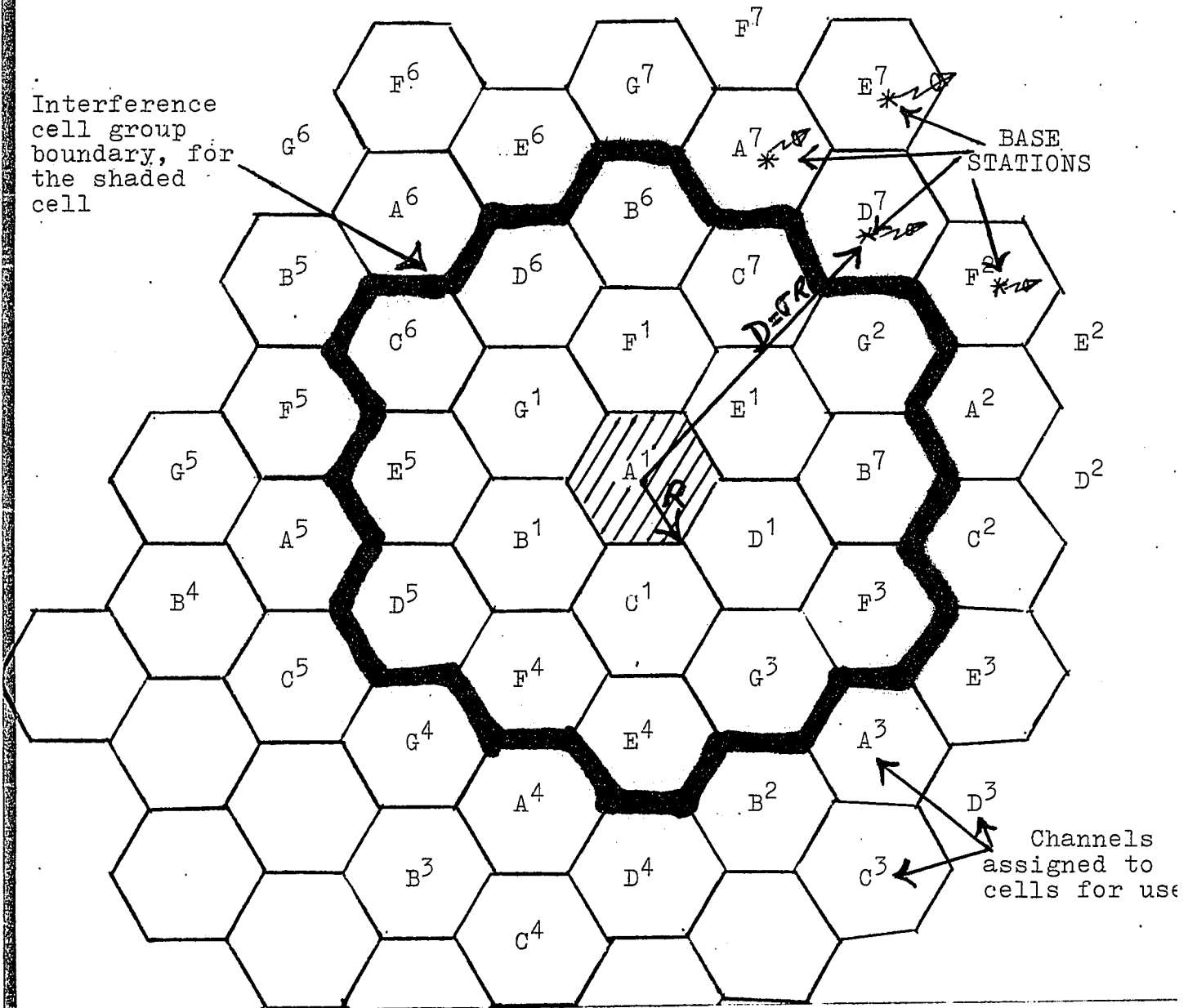
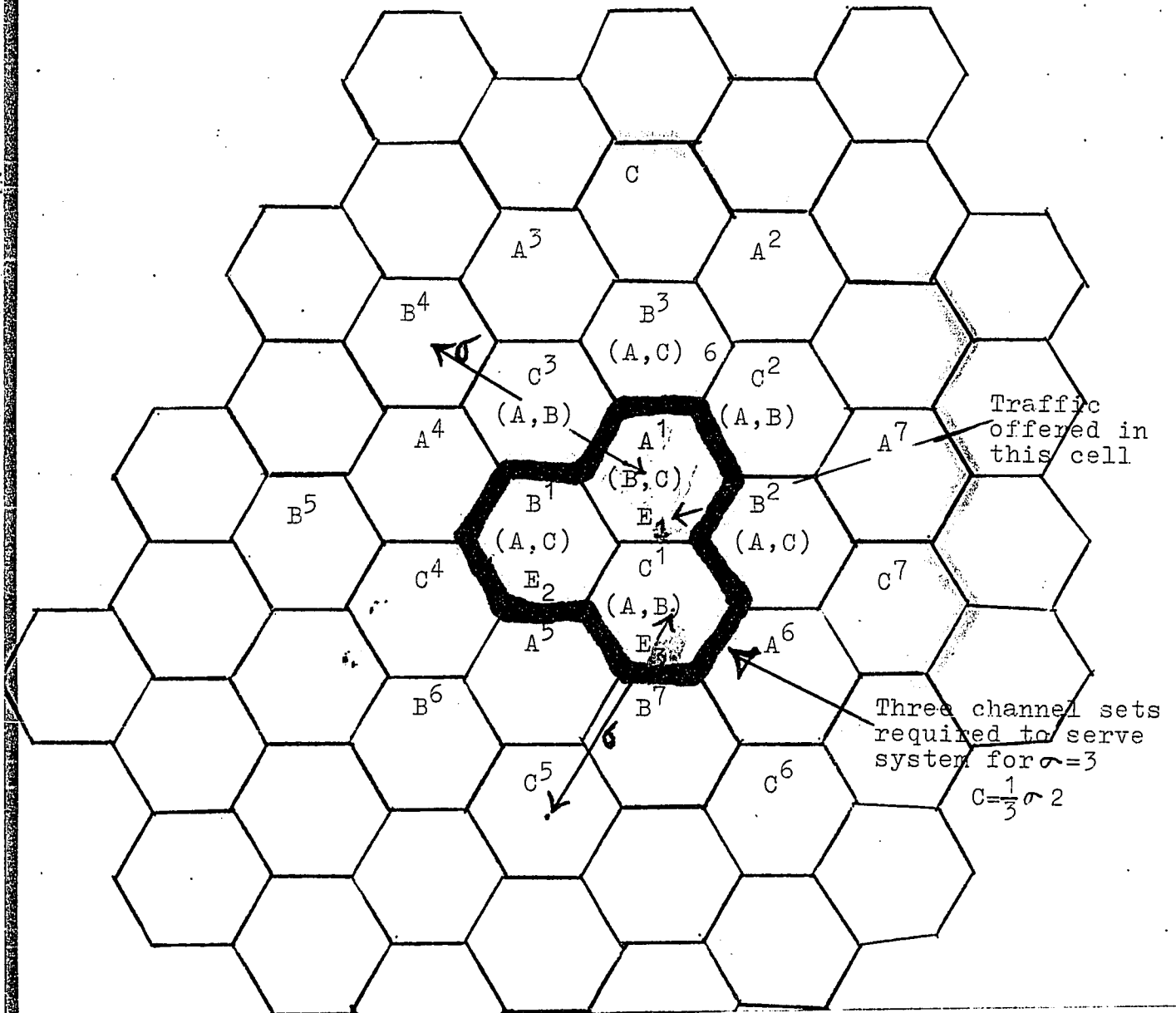

FIG. 2.3. FIGURE TO HELP CLARIFY CONCEPTS INVOLVED IN CELLULAR LAYOUTS.



KEY:  $A^i, B^i, C^i$  - sets of channels that are assigned to cells for use there as first choice.

$(A,B), (A,C), (B,C)$  - sets of channels that can be borrowed for use in the cells where indicated, provided such borrowing meets interference constraints imposed on the system.

FIG. 2.4. HEXAGON CELLULAR LAYOUT.

different cell for the  $i^{\text{th}}$  time and set B for the  $j^{\text{th}}$  time. Channel sets  $B^j$  and  $B^{j+1}$  do not have to be equal as will be explained later.

If we define the channel occupancy as the fraction of time that a channel is in use, then clearly the repeated usage of channels in different cells will mean that for any given channel, its occupancy will be higher in a cellular system than in a 'global system' for the same blocking probability, also known as grade of service. In re-using channels, we must space them out at least a minimum distance apart, to minimize co-channel interference, which would result if different calls were to be served in neighbouring cells simultaneously, using the same radio channel. For any given channel, the minimum relative distance  $\sigma$  ( $\sigma = D/R$ , where D is the physical distance between two base stations using the same frequency and R is the radius of the hexagons) between any two of its nominal cells is governed by the ratio of desired to undesired (D/U) signal levels of the system. At any point away from the base transmitters, D/U is affected by the propagation characteristics of the region.

Because of the required separation  $\sigma$  between the nominal cells for a given channel, there will be a group of cells that have to be assigned other channels for use. This group of cells is called the interference cell group.

From Fig. 2.3, the interference cell group for the channel set  $A^1$  is bounded by the thick black contour. Any channel within the set  $A^1$  can not be re-used, within the interference cell group, if already in use there.

An immediate question arises as to whether there is any relationship between  $\sigma$  and the number of cells that form the interference cell group. Furthermore, what is the relation between  $\sigma$  and the minimum number of different channel sets that are required to serve the interference cell group. If the geometric shape of the cells used is hexagon, then for a given  $\sigma$ , the number of channel sets (CS) required is given by the expression  $CS = \frac{1}{3} \sigma^2$ , where CS can assume only the values of 3,4,7,9,12, as generally represented by the relation  $CS = (k+1)^2 - k$  (30). But if the cells used have square geometric shapes, then the number of channel sets required for a given  $\sigma$  is  $CS = \frac{1}{2} \sigma^2$ , with CS restricted to assume any value from the set 2,4,5,8,9, etc. (29,30).

Therefore, from the discussion so far on cellular systems, we see that the number of times a given channel can be re-used simultaneously in the service area will depend on, in one way or another, on the following:

- (a) Propagation characteristics of the region
- (b) Power of the transmitters
- (c) Size of cells used
- (d) Quality of Transceivers, e.g. Sensitivity
- (e) Frequency band of operation

## 2.2 BASIC CHANNEL ASSIGNMENT SCHEMES

Assuming that we have a cellular structured mobile communication system layout, a point of interest is to decide on what Channel Assignment Scheme (CAS) to use. One such scheme is the Fixed Channel Assignment (FCA), where channels can only be used in designated cells (5,7, 9, 22, 29, 30). In this case there is a definite relationship between cells and channels that can be used there at any time. From Fig. 2.3, if the channel sets have been assigned to cells, as shown, then in the Fixed Channel Assignment scheme these will be the only channels allowed for use in their respective cells. For example, if the channels in set A<sup>1</sup> are all occupied in the shaded cell, and another request for service is made in this same cell, then this new call will be blocked as there are no more channels for use, though it might be that one or more of the neighbouring cells have one or more of their nominal channels free at the time, which could be borrowed for temporary use.

Another channel assignment scheme is the Dynamic Channel Assignment (DCA). In the DCA approach, there is no need of assigning different channel sets (A, B, C, etc.) to the different cells of an interference cell group. Channels are assigned to serve calls in any cell in real time, provided such assignment respects the minimum spacing of (the resulting average spacing between cells

using the same channel depend on the criterion (algorithm) of borrowing, but it is usually larger than  $\sigma$ ). These channels are temporarily borrowed from a central pool for use by the cells and then returned to the pool, when service is over (1,5,7,8, 30). Usually there is more than one channel in the pool and therefore one has to decide which one, out of all the eligible channels, to borrow for use. The following schemes for a cell borrowing a free channel have been investigated.

- (a) Borrow the very first channel found in the search that satisfies the interference constraint, that is a channel that is not being used in any cell which is also a member of the interference cell group for the particular cell in question.
- (b) Borrow a channel that is being used nearest to the cell that wishes to borrow, that is, at a distance  $\sigma$ . The search for a channel using this criterion would involve searching for a channel as in (a) above, and then testing to see if it is currently being used in any cell bordering the interference circle (9, 7, 30).
- (c) Borrow a channel using the same criterion as in (b) above, except using the minimum distance as  $(\sigma + k)$ , where  $k=1,2$  or  $3$ . This added distance between cells using the same channel is

for the purposes of facilitating mobiles, which are currently receiving service, to go across cell boundaries and still keep the same channel. They would, if necessary, just change the base transmitters serving them (7, 9, 10, 30).

- (d) Borrow that channel that is currently being used most at the minimum distance  $\sigma$ . This means that for each and every channel that qualifies for borrowing (as in (a) above), we count the number of cells that are using it next to the interference circle. That channel with the highest number is borrowed. For  $\sigma$  used in Fig. 2.3, the maximum number will be six. Therefore, if more than one channel is being used a maximum of six times, then the first one encountered in the search is borrowed. (9, 10, 30).

The Fixed Channel Assignment and Dynamic Channel Assignment are two 'definite' policies. Definite in that over the entire area for service, and for all time, channels are either assigned with Fixed Channel Assignment or Dynamic Channel Assignment disciplines. There are two other channel assignment schemes, which are a combination of FCA and DCA. The third CAS will be called Constrained Dynamic Channel Assignment (CDCA) scheme (1). The fourth and last CAS of interest in this research is the Hybrid Channel Assignment (HCA) scheme (5). Explanation of these channel assignment algorithms will be given in subsequent sections.

### 2.3 PROBLEM STATEMENT

In the context of this research, the channel assignment problem can be stated as follows:- Given the total number of available radio channels (full duplex) for mobile communication and a cellular system with a minimum re-use distance of  $\sigma$  cell radii units (Fig. 2.3), what CAS should be adopted, in order to realize the highest average channel occupancy and therefore have maximum traffic served at the desired grade of service.

### 2.4 PRESENT LITERATURE

The following problems are associated with the cellular approach:

- a) Mobile identification and techniques for monitoring its position, whenever necessary;
- b) Switching plan between mobile switching office (MSO) and base station. Communication between base station and mobiles within its coverage area;
- c) Inter-connection of mobile system to public land telephone facilities via the MSO;
- d) Provision of 'suitable' equipment, both in power requirements and performance, to operate at the allocated frequencies for this service;
- e) Channel assignment techniques.

Since 1968, many papers have been published on the above topics. We will be concerned with problem (e) only.

#### 2.4.1 FIXED VS DYNAMIC CHANNEL ASSIGNMENT SCHEME

The two above CAS have been studied quite extensively (7,8,9 ,13,22), and the results from system simulations have shown that for low blocking probabilities, the dynamic system performs much better than the Fixed Channel Assignment system. But for very high blocking probabilities, which is synonymous with very large offered traffic, the Fixed Channel Assignment scheme performs better.

The traffic in each cell has a Poisson distribution with known average traffic-offered in Erlangs. The initiation of requests for service from cell to cell is a random process and, therefore, when Dynamic Channel Assignment is being used, the different channels are assigned to serve calls at random too. Because of this randomness, it is found that cells that have borrowed the same channel for use are on the average, spaced apart at a greater distance than the minimum possible distance  $\sigma$  . Consequently Dynamic Channel Assignment schemes are not always successful in re-using the channels at the maximum possible number of times. But for Fixed Channel Assignment systems, the channel assignment to cells is done observing the minimum spacing  $\sigma$  , and, therefore, it has a higher channel re-use. This is why, in order to improve the performance of

Dynamic Channel Assignment systems at large traffic offerings, it has been suggested to use Channel REassignment techniques (5). The basic goal of Channel REassignment is to switch calls already in progress, whenever possible, from channels that these calls are using, to other channels, with the objective of keeping the distance between cells using the same channel simultaneously to a minimum.

It has been found that in the case of Dynamic Channel Assignment, the system is not overly sensitive to time and spatial changes in offered traffic, giving rise to almost stable grades of service in each cell (6). But for the Fixed Channel Assignment scheme, the service deviation, a measure of the grade of service fluctuations from one cell to another, is very much worsened by these said traffic changes. Another point in favour of DCA over FCA, as deduced from simulation results, is the seeming dependence of the grade of service within an Interference cell group (See Fig. 2.3) on the average loading within that group and not on its spatial distribution (1, 6).

A channel assignment scheme that is superior to FAC and DCA, and which will be called in this thesis constrained dynamic CA, was proposed by Engel and Perisky (10) and its performance was evaluated by Anderson (1) by comparing it to two other channel assignment schemes, using some simulation results. From his results, Anderson concluded

that the CDCA scheme behaved like a full access system, with the number of channels equal to the total channels available for use in the heaviest loaded interference cell group. Also of interest to note is that Anderson's results seemed to indicate, and he himself states, that this theoretical full access system's performance serves as an upper bound on the system traffic handling capacity. This means that, assuming the dark bounded interference cell set (Fig. 2.4) has the highest offered traffic of  $(E_1 + E_2 + E_3)$  than any other I.C. group, then the performance of this I.C. group, regardless of the distribution of  $E_1$ ,  $E_2$  and  $E_3$ , is similar to that system with  $(A^1 + B^1 + C^1)$  channels and a load of  $(E_1 + E_2 + E_3)$ .

#### 2.4.2 CONSTRAINED DYNAMIC CHANNEL ASSIGNMENT (CDCA) SCHEME.

In this scheme, each cell has two sets of channels for its use, shown in Fig.2.4 as  $A^1, B^1, C^1$  and  $A, B, A, C, B, C$ . The former type of sets contains the nominal channels. These channels have been assigned to the cells observing the minimum interference spacing and in all cases are to be preferred for use in their respective cells (nominal cells). If all nominal channels for a particular cell are busy, when a new call originates or arrives in a particular cell, then borrowing may take place from the borrowable set, shown in brackets in that cell, provided no interference will result as a consequence of this borrowing. It is of interest to note that the set in brackets may contain many channels and therefore the decision, on which channel of the set will be borrowed, is important. Some papers have been published on this subject, advancing different criteria for channel borrowing and investigating the system performance (1, 10).

A general conclusion reached by most authors on this subject was that, adopting a simple test for borrowing, for example, borrowing the first available channel that satisfies the  $\sigma$  constraint, yields performance results quite comparable to systems, which do a lot of exhaustive searching for channels that are the ultimate best for borrowing, thus giving rise to a lot of processing per

call. Because of this reason, in this research, the criterion for borrowing was simply to use the first available channel in the search.

In the next chapter, we are presenting our extension of a hybrid channel assignment scheme.

## CHAPTER 3

### HYBRID CHANNEL ASSIGNMENT

#### 3.1 INTRODUCTION

In the Hybrid Channel Assignment scheme, we employ a mixture of two schemes (thus the name Hybrid). These are the Fixed and the Dynamic Channel Assignment schemes. Assume we have a total of  $T$  duplex channels for service and that they are divided into two sets A and B, not necessarily equal. Let us further assume that set A is used for Fixed Channel Assignment and set B for Dynamic Channel Assignment.

In the Hybrid Channel Assignment scheme, every cell in the system is assigned a number of permanent channels exclusively for use there, proportional to the traffic requirement in it. If the offered traffic per cell is uniform, then each cell will have an equal number of fixed channels assigned to it. But if the offered traffic is not distributed spatially evenly, then the fixed channels will obviously vary in number from cell to cell. Regardless of whether the traffic is spatially uniform, the number of different fixed channel sets ( $c$ ) that will be required is still determined by the  $\sigma$  relationship, as explained earlier in section 2.1. The channel set B

contains channels that can be used in any cell in the system, using the Dynamic Channel Assignment scheme.

This approach was inspired by Cox's paper (5). In his paper he treated a case of only ten channels, on the average, in each cell ( Average number of channels per cell =  $\frac{\text{Total available channels}}{\text{Number of channel sets required for the given } \sigma} = \frac{T}{C}$  ). Furthermore, he assumed equal traffic loading in all cells, a point far from reality. In his work, Cox found that for the division of the ten channels into a ratio of 8:2 of Fixed vs Dynamic, the system carried more traffic than if all the ten channels had been used in either a Fixed or Dynamic mode. The two dynamic channels that were realized from each cell, were given to the entire system for use in the Dynamic mode.

In this thesis, we present a Hybrid Channel Assignment scheme for a system that has non-uniform offered traffic, which tries to satisfy the following goals:

- (a) Systems that employ Dynamic Channel Assignment schemes, exhibit considerable service deviation, especially at large blocking rates. This service deviation (SD) has been defined by Anderson (1), as:-

$$SD = \left[ \frac{\sum_{c=1}^N (B_c - \bar{B})^2}{N - 1} \right]^{1/2}$$

where  $\bar{B} = \frac{1}{N} \sum_{i=1}^N B_i$ .  $\bar{B}$  is the average number of blocked calls in the entire system,  $B_i$  is the fraction of calls blocked in cell  $i$  to the calls carried in a given time interval, and  $N$  is the total number of cells in the system.

Therefore a well-designed mobile communications system should have a service deviation value of close to zero. The hybrid channel assignment scheme, with a considerable number of dynamic channels, will be able to respond to spatial shifts in offered traffic and therefore prevent large numbers of calls from being blocked.

(b) It is important, in electronic switching systems, to keep the software projected real-time load on the processor to a minimum. In mobile communication systems, this software real-time load to the processor is very much dependent on the average number of functions (operations) needed to complete each call. The Fixed Channel Assignment schemes require, on the average, a smaller number of functions to complete a call, than the Dynamic Channel Assignment schemes. Since the Hybrid Channel Assignment scheme uses both Fixed and Dynamic Channel Assignment schemes, its average number of functions performed per call will be in between that of the fixed and Dynamic, provided comparisons are made on exactly the same system for the three channel assignment schemes.

Therefore, using Hybrid, instead of Dynamic Channel Assignment schemes, will enable the processor to complete (handle) more calls per unit time. But we do not expect the degree of hardware and software system complexities to be lessened. The reason for this is that, once it is necessary to borrow a dynamic channel, the steps and decisions the processor will make, will have to be the same as if the entire system had been dynamic. The only advantage of Hybrid over Dynamic Channel Assignment, in terms of average processing time per call, is that in the case of the latter, there are many more channels to consider each time a request for a free channel is received.

(c) In the development of the model for call-attempt rates ( 30 ), the assumption was made that call-attempts associated with each car occur at random and independently from those of other cars. But this is not always the case because experience with present 'global systems' has shown that there is a considerable traffic between mobile-to-mobile users, as opposed to land-to-mobile and mobile-to-land calls. Therefore, if there is a considerable number of cases of mobile-to-mobile calls within the same radio cell, as might happen in cases of police, ambulance and heavy mobile traffic, the grade of service will deteriorate in cases where Fixed Channels were assigned using the independent assumption. The Hybrid Channel Assignment will solve this potential problem quite easily by using the available dynamic channels.

### 3.2 STEPS FOLLOWED IN THE HYBRID CHANNEL ASSIGNMENT SIMULATIONS AND EVALUATIONS.

In this thesis we consider a system having uniform spatial offered traffic, which uses a Hybrid Channel Assignment scheme. The steps involved are as follows:

1. We assume that the long term average offered traffic in Erlangs is known. Then using the tables for the Erlangs .B traffic formula, we determine the number of channels required in each cell to give the desired grade of service, assuming that a Fixed Channel Assignment scheme is in use. The desired number of channels for cells 1,2,3,etc... are represented by  $(NC)_1$ ,  $(NC)_2$ ,  $(NC)_3$ , etc...
2. Then we consider a mobile communications system with uniformly offered traffic that requires  $(NC)_1$  channels per cell, on the average, where again,  $(NC)_1$  is given by  $\frac{T}{C}$ . (see Section 3.1). We then find, through GPSS simulation, the ratio of Fixed to Dynamic channels that carry the most traffic at the desired grade of service. Let this ratio be represented as  $k_1:l_1$  where  $k_1$  is the average number of static channels per cell and  $l_1$  is the average number of Dynamic channels per cell and  $k_1 + l_1 = (NC)_1$

The above procedure is repeated for the case of  $(NC)_2$ ,  $(NC)_3$ , etc...

3. Now using the results obtained in Step 2 above, channels are assigned to the cells of the mobile communications system. In Fig. 2.4, for example, cell 1 has offered traffic of  $E_1$  Erlangs and normally  $(NC)_1$  channels would be needed to give a desired grade of service. But from the simulation results only  $k_1$  channels are assigned to cell 1 and  $1_1$  channels are given to the entire system for use as Dynamic channels.

### 3.3 DESCRIPTION OF SIMULATED SYSTEMS

1. For the investigation of the optimum division between fixed and dynamic channels, a system with a very large cellular layout should be used but the statistics should be collected from the central cells. The reason for considering large cellular layout was to overcome the edge effects. Using a finite system for this kind of study is bad because the cells around the edges do not have enough neighbouring cells to cause calls to be blocked, whereas the centrally located cells have a lot of neighbouring cells and therefore every time the central cells wish to borrow, chances are the neighbouring cells will be using the desired channels. This gives rise to the central cells having higher blocking probabilities than those at the edges.

For comparing the Hybrid Channel Assignment system performance, exactly the same cellular layout as studied by (1) was used. This was because we did not wish to have the results affected by the different cellular layout.

2. The calls in each cell are assumed to have a Poisson distribution with known arrival rate,  $\lambda_i$  calls/hours.
3. The service time per call, in any cell, is assumed to be exponentially distributed, with a mean of 120 secs.

Thus the loading will be  $\frac{\lambda_i \times 120}{3600} = \frac{\lambda_i}{30}$  (Erlangs)

4. The first available channel in the search, that satisfies the spacing constraint  $\sigma$  is borrowed for use.
5. It is assumed that the mobiles are identifiable entities and could operate on any channel, as dictated by the base stations.
6. The base stations could transmit on any borrowed frequency at all times, as assigned to them by the system controller.
7. The simulation was done using GPSS/360 version 01 Level 03, and therefore the system statistics were gathered by keeping track of all events that occurred in the simulated system. The flow-chart and block-diagram of the programme used are presented in the appendices.

## CHAPTER 4

### GPSS SIMULATION RESULTS

The system that was simulated is shown in Fig. 4.1. Forty cells were considered and statistics were taken from the central twenty cells. We decided to use only forty cells because of the constraints imposed by GPSS, as is explained in Appendix A.

First the simulations were done for the case of ten channels on the average per cell, in an attempt to verify Cox's results (5). The results are presented in Fig. 4.2. The Y-axis represents the average blocking in the twenty middle cells and is computed by simply finding the ratio between blocked calls to served calls in a given time period. The X-axis represents the percentage increase in loading over the Fixed Channel Assignment system. The percentage increase in loading is calculated in the following manner. First, from the tables for the Erlang B traffic formula (28), we found what traffic rate in Erlangs was required so as to have a grade of service; that is, probability of blocking, of 0.018, with ten fixed channels per cell. In this case and for ten channels, the traffic rate is five erlangs. Therefore, this figure of five erlangs is used as the basis for the calculations of the percentage traffic increase.

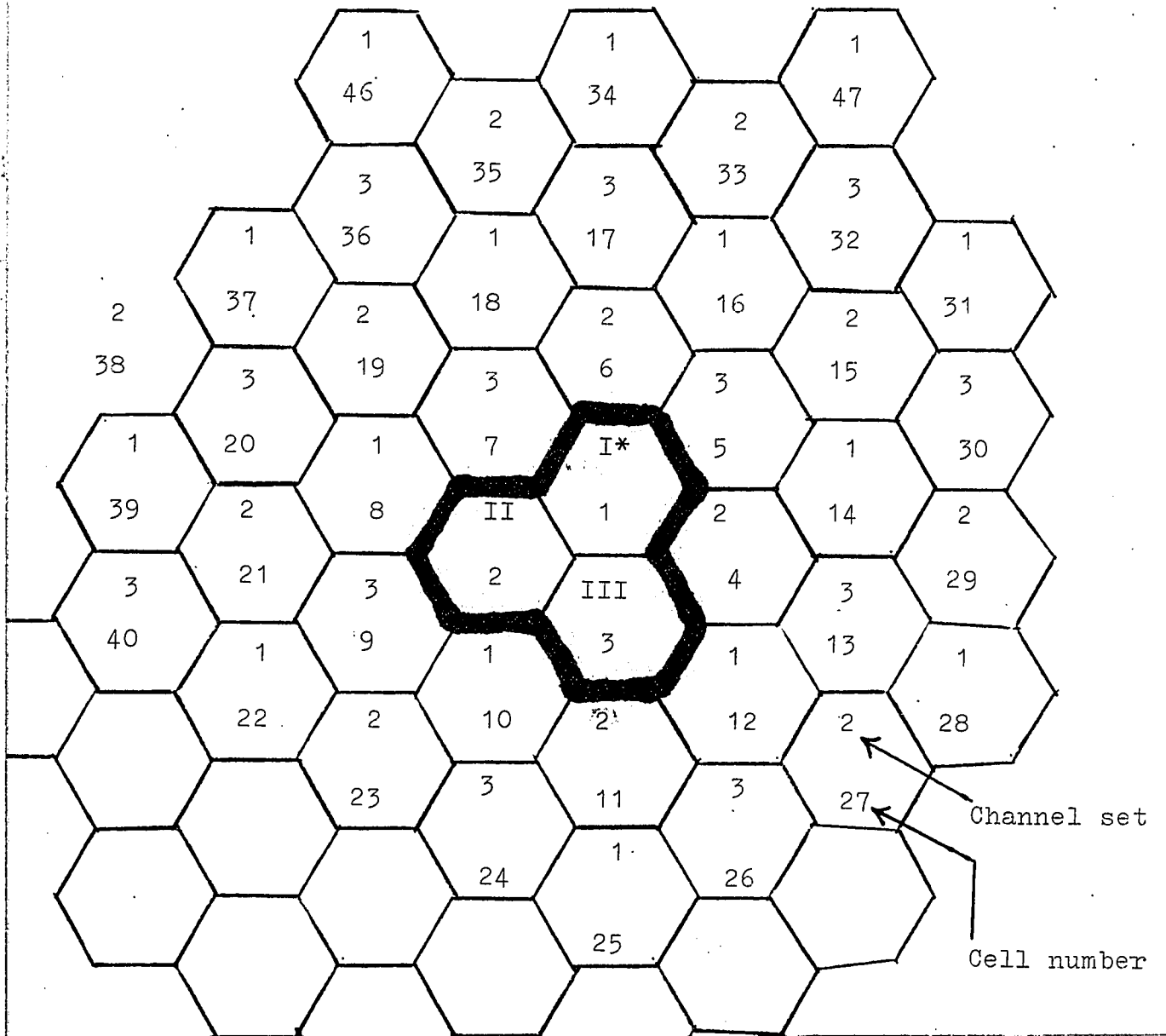

FIG 4.1. CELLULAR LAYOUT FOR SYSTEM THAT WAS SIMULATED

In the particular case of ten channels, the traffic rate was increased from five to ten erlangs, in steps of one erlang, as is shown in table 4.1. The results are similar to Cox's (5) and clearly show that the ratio of eight fixed to 2 dynamic channels gives the lowest blocking probability, for percentage increases in traffic loading of up to 75%. Beyond 75% traffic load increases, the fixed system performs better, for reasons that were explained in Section 2.4.1.

From Fig.4.1, we see that we require at least three different channel sets in order to assign channels to all cells, with  $\sigma$  equal to 3. Since the entire forty-cell system is served by three sets of channels, when the division into static to dynamic channels is done, only  $3 \times l_1$  channels are made available for use as dynamic channels over the entire system, where  $l_1$  was defined in Section 3.2. In the particular case of 8:2 division, we get  $3l_1 = 6$  dynamic channels for use over the entire system. Therefore, while before the channel partition, the average number of channels per cell was ten, after the partition, the average number of channels per cell is  $8 + \frac{3 \times 2}{7} = 9$  as obtained from the following relationship:

$$\text{Total average number of channels/cell} = k_1 + \frac{3 l_1}{\text{I.C.}}$$

where  $k_1$  and  $l_1$  have the same meaning as explained in Section 3.2. I.C. is the number of cells contained in an interference cell group.

The table below summarizes the different system configurations simulated.

Average channels per cell in uniformly loaded system and fixed channel assignment scheme	Channel partitions for Hybrid simulations		Traffic loadings in Erlangs used in the simulation
	Fixed	Dynamic	
10	8	: 2	* 5,6,7,8,9,10
	5	: 5	
	10	: 0	
18	18	: 0	* 11,12,13,14,15,16
	16	: 2	
	14	: 4	
	12	: 6	
28	26	: 2	* 20,21,24,27,30,33
	24	: 4	
	22	: 6	
	20	: 8	
35	35	: 0	* 26,28,30,32,34
	33	: 2	
	31	: 4	
	28	: 7	
	25	: 10	

Table 4.1: Different system combinations investigated.

\* - Base loads

It is very important to understand the meaning of average number of channels per cell before and after the division. In Cox's paper (5), the two terms give the same results because he used as many different channel sets as there were cell members in the interference cell group. But in our case of cellular arrangements, we do not need as many different channel sets as there are members in the interference cell group. Because of this, fewer cells than those in the I.C. group, donate some of their channels for dynamic use. Therefore when we talk about a division of  $k_1 + l_1 = (NC)_1$ , we are talking about those cells that are actually doing the donating of channels to the system. The resulting average number of channels per cell for the entire system is given as above, by  $k_1 + \frac{3 l_1}{I.C.}$ .

We find that though, after the channel division, the average number of channels per cell is less than before the division, the number of calls that can be handled at the same grade of service has improved substantially, as can be seen from Figures 4.2 to 4.6.

From Figure 4.2 we notice that for load increases of up to 15% the channel division of 5:5 is better than the 8:2 channel partition. This fact does not show on Cox's graph (Fig. 3, Ref.5) because the scale on the right for the calls blocked is not expanded well enough. But as the offered load is increased beyond 15%, then the 8:2 partition gives the best results,

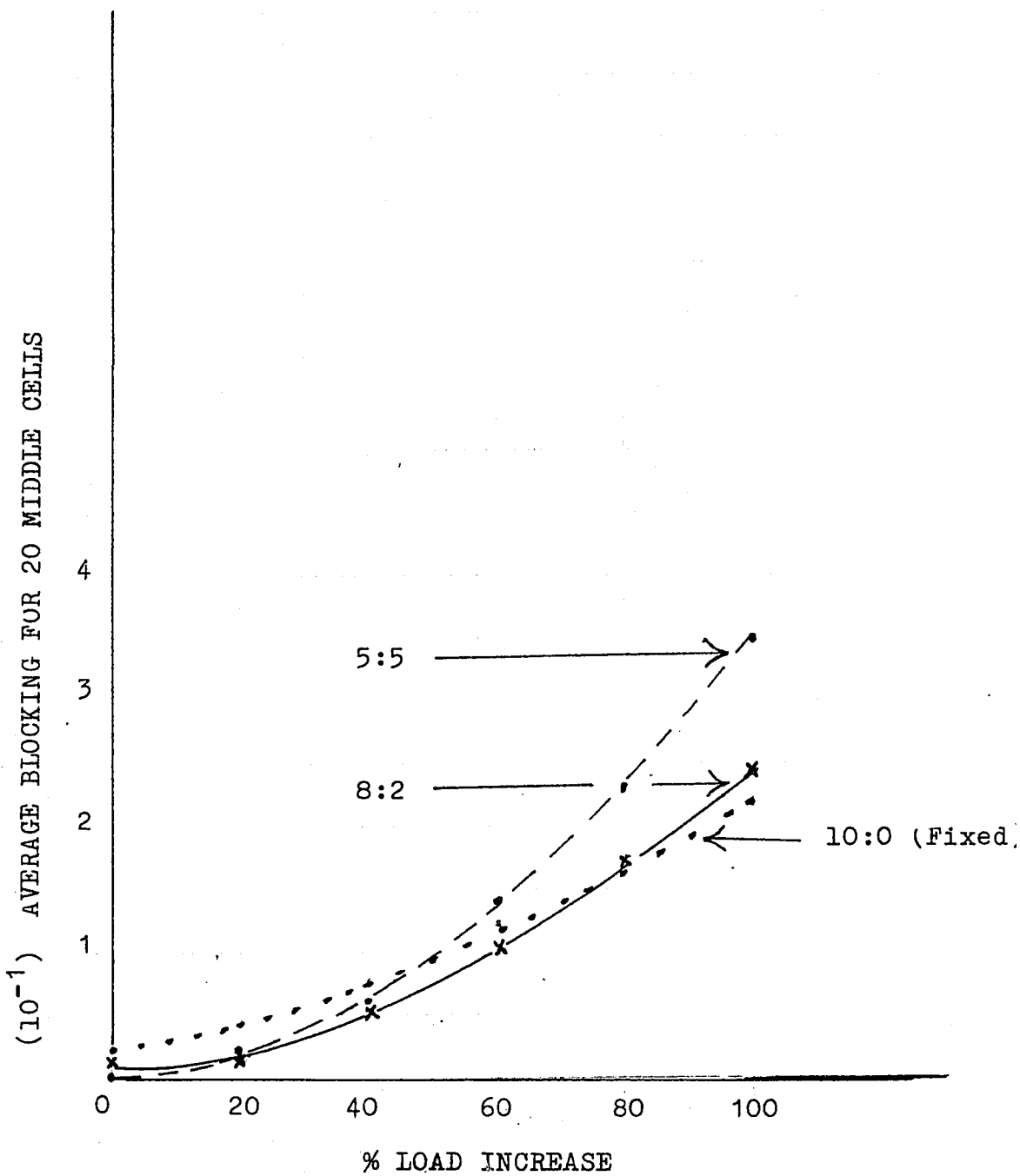

FIG. 4.2 PERFORMANCE OF SYSTEM WITH INITIALLY 10 FIXED CHANNELS PER CELL

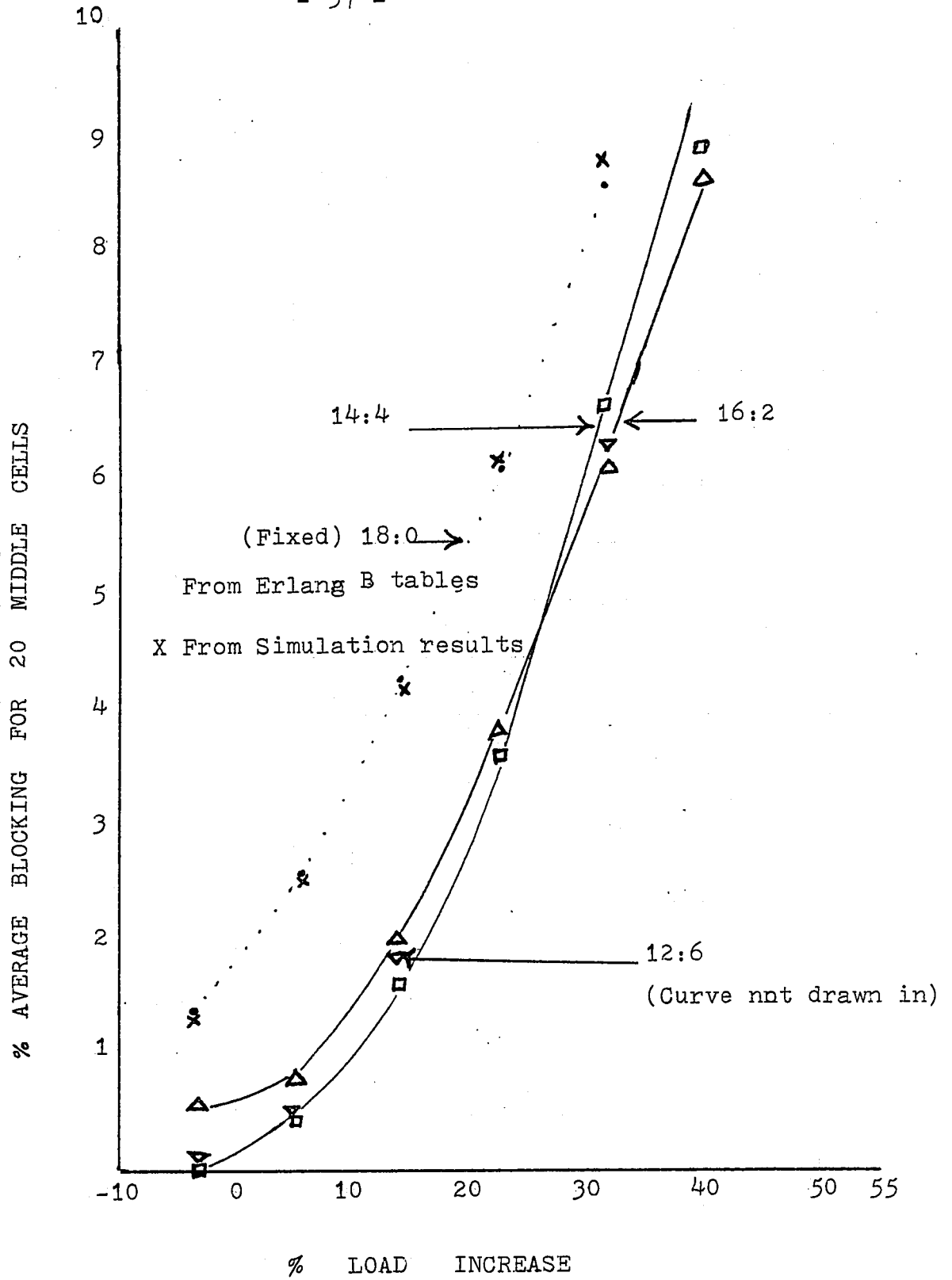

FIG. 4.3 PERFORMANCE OF SYSTEM WITH INITIALLY 18 FIXED CHANNELS PER CELL

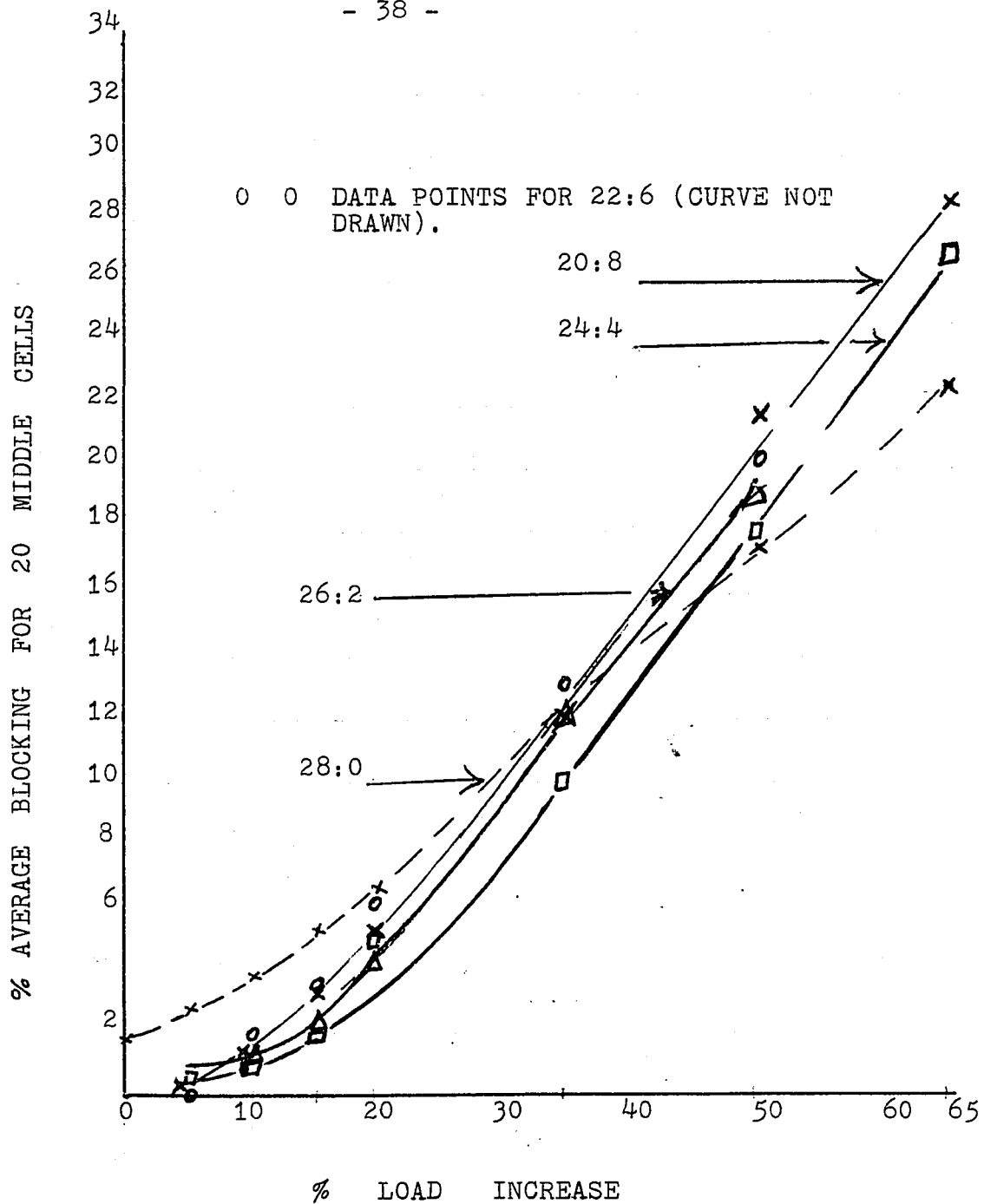

FIG. 4.4 PERFORMANCE OF SYSTEM WITH INITIALLY 28 FIXED CHANNELS PER CELL

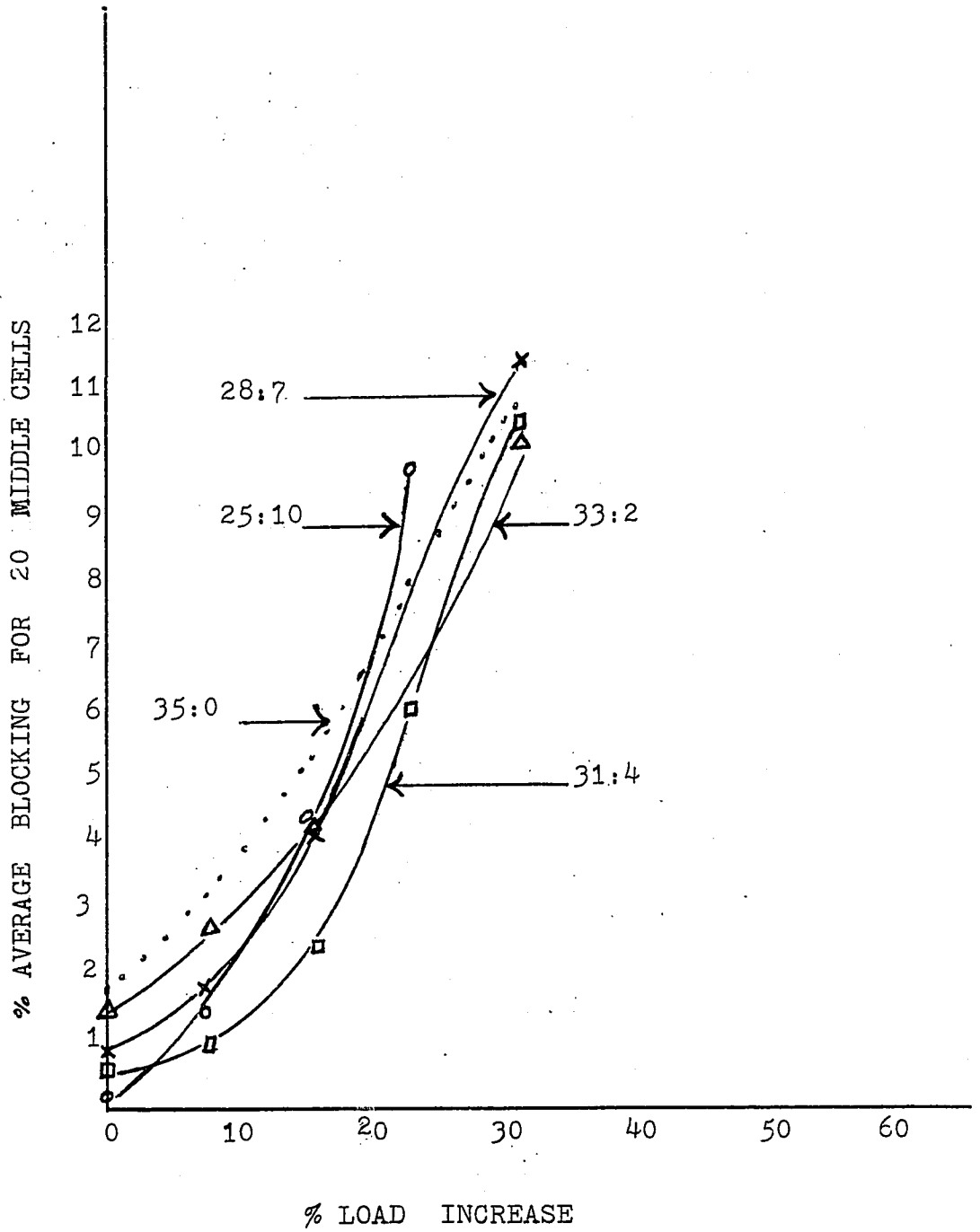

FIG. 4.5 PERFORMANCE OF SYSTEM WITH INITIALLY 35 FIXED CHANNELS PER CELL

in terms of grade of service, up to about 75% load increase.

Figure 4.3 shows results obtained from simulation of a system that had uniform load offering of 11.4 erlangs, on the average, per cell.

In this case, besides running simulations for the cases indicated in Table 4.1, we also simulated it using fixed channel assignment scheme. The results obtained are plotted on Figure 4.3 and they lie almost exactly on the Erlang-B Curve for 18 servers. Simulations using fixed channel assignment scheme were done for the cases of 10, 18 and 35 channels on the average, per cell. This was done so as to check on the validity of the simulator programme. The particular results of 18 channels on the average is plotted here to indicate the close match of results from the simulation and analytic results.

We again notice, from Figure 4.3, that for load increases below about 15%, channel partitions of 12:6 and 14:4 gives the lowest probability of blocking. Then as the load is increased beyond about 17%, the channel partitions of 14:4 and 16:2 start to give better results. The 14:4 channel partition gives the best results up to about 30% load increase. Beyond 30%, the 16:2 gives the best results. In this case the load increase was taken only up to 42%, but from the figure, it may be obtained that beyond about 50% load increase, the fixed channel assignment scheme would have given the lowest

probability of blocking.

From Figures 4.4 and 4.5, we notice the same general trend in results. For low blocking probabilities and load offerings close to the base, channel partitions that have the most dynamic channels, give the best results. But as the offered load is increase beyond about 15%, then channel partitions with medium numbers of dynamic channels perform the best. Beyond about 50% load increase, it is found that systems that employ fixed channel assignment schemes give the lowest probability of blocking.

## C H A P T E R 5

### CONCLUSION

The results that we obtained indicate that usage of the hybrid channel assignment scheme gives better grades of service than systems that employ fixed channel assignment scheme for load increases of up to 50% above the base load. Beyond this load increase, the fixed channel assignment has been found to perform better, in all cases that were studied. We considered cases where we assigned up to 33% of the channels available per cell, for dynamic use. In all cases, the results followed the same general pattern. For load increases of up to 15%, systems with most dynamic channels, gave the lowest probability of blocking. For load increases of between 15% and about 35%, systems with a medium number of dynamic channels performed better and finally, above about 50% load increases, it was found that systems that employed fixed channel assignment gave the best results.

The general nature of these results is very reasonable, in light of what has been published in earlier literature. It was found that dynamic channel assignment performed best at low load offerings. When the load was increased substantially, it was found that the fixed system performed best, because of its optimal re-use of the channels (see Section 2.4.1).

The hybrid channel assignment technique, at load offerings near the base load (the base load is that traffic offering in erlangs, which will give a blocking probability of 0.018) behaves as if the load offered to the dynamic channels is low. This is because the traffic offered is shared, though not equally, between the fixed and dynamic channels. Therefore, there is not much blocking at low percent load increases. But as the load is increased to about 15% above the base load, then systems with a lot of dynamic channels begin to block calls quite substantially. This phenomenon is again characteristic of dynamic channel assignment systems to block many calls at high rates of offered traffic.

For systems with 15% to 20% of their fixed channels being used as dynamic channels, significant blocking does not start to be a major factor till the load has been increased to about 40% above the base line.

If, however, a certain maximum blocking probability is specified, the above conclusions will have to be revised since they obviously depend on that probability.

We hope that these results will be of use to those designing cellular structured mobile communication systems.

## REFERENCES

1. Lewis G. Anderson, "A Simulation Study of Some Dynamic Channel Assignment Algorithms in a High Capacity Mobile Telecommunications System," IEEE Trans. Veh. Technol., Vol. VT-22, pp.210-217, Nov. 1973.
2. Kin'ichiro Araki, "Fundamental Problems of Nation-Wide Mobile Radio Telephone System," Rev. Elec. Commun. Lab., Vol. 16, pp. 357-373, May-June, 1968.
3. Albrecht P. Barsis, "Determination of Service Area for VHF/UHF Land Mobile and Broadcast Operations Over Irregular Terrain," IEEE Trans. Veh. Technol., Vol. VT-22, pp. 21-29, May 1973.
4. J. R. Brinkley, "Future for Mobile Radio and Paging in Europe," TCS Telecomm., Vol.8, pp.27-29, May 1974.
5. Donald C. Cox and Douglas O. Reudink, "Increasing Channel Occupancy in Large-Scale Mobile Radio Systems: Dynamic Channel REassignment," IEEE Trans. Veh. Technol., Vol. VT-22, pp.218-222, Nov. 1973.
6. \_\_\_\_\_ "Effects of Some Non-uniform Spatial Demand Profiles on Mobile Radio System Performance," IEEE Trans. Veh. Technol., Vol. VT-21, pp.62-67, May 1972.
7. \_\_\_\_\_ "A Comparison of Some Channel Assignment Strategies in Large-Scale Mobile Communication Systems," IEEE Trans. Commun., Vol. COM-20, pp.190-195, Apr. 1972.
8. \_\_\_\_\_ "Dynamic Channel Assignment in High Capacity Mobile Communications System," Bell Syst. Tech. J., Vol. 50, pp. 1833-1857, July-Aug. 1971.
9. \_\_\_\_\_ "Dynamic Channel Assignment in Two-Dimensional Large-Scale Mobile Radio Systems.," Bell Syst. Tech. J., Vol. 51, pp. 1611-1629, Sept. 1972.
10. Joel S. Engel and Martin M. Peritsky, "Statistically-Optimum Dynamic Server Assignment in Systems with Interfering Servers," IEEE Trans. Veh. Technol., Vol. VT-22, pp. 203-209, Nov. 1973.
11. J. S. Engel, "The Effects of Co-channel Interference on the Parameters of a Small-Cell Mobile Telephone System," IEEE Trans. Veh. Technol., Vol. VT-18, pp. 110-116, Nov. 1973

12. Zachary C. Fluhr and Eric Nussdaum, "Switching Plan for a Cellular Mobile Telephone System," IEEE Trans. Veh. Technol., Vol. VT-22, pp.198-202, Nov. 1973.
13. Richard H. Frenkeil, "A High-Capacity Mobile Radiotelephone System Model Using a Coordinated Small-Zone Approach," IEEE Trans. Veh. Technol., Vol. VT-19, pp. 172-177, May 1970.
14. Arthur D. Little, "Is Mobile at a Standstill?" ITS Telecommun., Vol. 9, pp.30-33, Feb. 1975.
15. John A McCormich, "Mobile Design Elements," TCS Telecommun. Handbook and Buyer's Guide, pp. 134-141, Sept. 1974.
16. John Fluke Manufacturing Co., "FCC and ITU Accuracy Requirements for VHF and UHF Bands," TCS Telecommun. Handbook and Buyer's Guide, pp. 142-145, Sept. 1974
17. Moriiji Kuwabara, "Recent Mobile Radio Communication System in NTT," Jap. Telecommun. Rev. Vol. 17, pp. 254-263, Oct. 1975.
18. Takuya Nomura and Noriaki Yoshikawa, "Mobile Radio Link Design," Rev. Elec. Commun. Lab., Vol. 23, pp. 144-160 Jan.-Feb. 1975.
19. Martin M. Peritsky, "Traffic Engineering of Combined Mobile Telephone and Dispatch Systems," IEEE Trans. Veh. Technol., Vol. VT-22, pp. 223-225, Nov. 1973.
20. Vikram Prabhu and Stephen S. Rappaport, "Approximate Analysis for Dynamic Channel Assignment in Large Systems with Cellular Structure," IEEE Trans. Commun., Col. COM-22, pp.1715-1720, Oct. 1974.
21. Chandos A. Rypinski, "Application of System Design Principles to High Channel Density Air-Ground Telephone Service," IEEE Trans. Veh. Technol., Vol. VT-18, pp. 19-27, May 1969.
22. Leonard Schiff, "Traffic Capacity of Three Types of Common-User Mobile Radio Communication Systems," IEEE Trans. Commun. Technol., Vol. COM-18, pp.12-21, Feb. 1970.
23. H. Staras and L. Schiff, "Improved Spectrum Utilization in the Land Mobile Radio Service," TCS Telecommun., Vol.4, pp. 23-32, Oct. 1970.
24. O. J. Wheaton, "Britain's Bobbies Evaluate Mobile Data Communications," ITS Telecommun., Vol. 9, pp. 39-42, Feb. 1975.

25. Noriaki Yoshikawa and Takuya Nomura, "Fundamental Co Consideration of Radio Zone Repetition in a Mobile Radio System," Rev. Elec. Commun. Lab., Vol. 23, pp. 161-171, Jan.-Feb. 1975.
26. Thomas J. Schriber, Simulation Using GPSS, John Wiley & Sons, New York, N.Y., 1974.
27. IBM General Purpose Simulation System/360 Introductory User's Manual, GH20-0303-4. 5th Edition. IBM, White Plains, N.Y., 1969.  
IBM General Purpose Simulation System/360 User's Manual GH20-0326-4. 5th Edition, IBM, White Plains, N.Y., 1970.
28. James, Martin, Systems Analysis for Data Transmission. Prentice-Hall, Englewood Cliff, New Jersey, 1972.
29. \_\_\_\_\_ Future Developments in Telecommunications, Prentice-Hall, Englewood Cliff, New Jersey, 1971.
30. W.C. Jakes, Jr. (ed.), Microwave Mobile Communications, John Wiley & Sons, New York, N.Y., 1974.

A P P E N D I C E S

## A P P E N D I X A

### THE GENERAL PURPOSE SIMULATION SYSTEM (GPSS)

#### INTRODUCTION

The problem that has been studied in this thesis is in the category of cases where use of the exact, or even approximate mathematical models is prohibitive, because of the complex relationships between the variables. Therefore simulation was used to obtain some typical results.

Simulation programmes can be classified into three levels, depending on how much coding has to be done by the user, in order to represent the physical system being simulated. The first level includes complete simulator programme packages for special problems, such as "Structural Simulation Analysis" and "Room-Temperature Analogue Simulator". Here all that is required is to compile the programme with suitable input parameters. The results are obtained without much programme writing by the user.

There are a few disadvantages in using such a programme, some of which are :

- a) It does not permit the system analyst to easily study alternative system configurations. For example, it may not be possible to investigate the effects of priorities and pre-emption etc., on the system performance.

- b) The user usually is unclear about the internal workings of the simulator package and therefore, he is sometimes unsure of the exact meaning (implications) of the results he might obtain.

The second category of simulator programmes is characterized by the use of a general computing language like FORTRAN or PL/I. With this approach, one has to write a lot of subroutines to gather the system statistics, to generate random numbers, to provide system clocks, etc. Besides, updating the system is usually tedious, as it involves changing a lot of parameters in the programme.

The third most common way of carrying out simulation studies is to use one of the many available simulation languages, such as SIMSCRIPT, SIMPAC, SIMULA and GPSS.

We decided to use IBM's General Purpose Simulation System/360, because it is one of the most popular languages used in simulation studies of queueing systems.

### GPSS

There are three main steps that have to be done in using GPSS. The first step involves describing the actual physical system using GPSS/360 entities. There are fourteen types of entities in GPSS/360 to help the model builder describe and represent the physical system. Entities can be thought of as the basic elements (concepts) that help to

translate (or transform) the real physical system to a similar system in GPSS/360. For instance, to represent a single server, one uses an equipment entity called a Facility. To show the presence of a Facility in a model, two kinds of blocks are used. The two blocks are SEIZE and RELEASE to represent the physical act of capturing a server and the completion of the service.

The fourteen types of entities are:

- |                           |                         |
|---------------------------|-------------------------|
| A. Basic entities         | 1. Blocks               |
|                           | 2. Transactions         |
| B. Equipment entities     | 3. Facilities           |
|                           | 4. Storages             |
|                           | 5. Logic Switches       |
| C. Computational entities | 6. Arithmetic variables |
|                           | 7. Boolean variables    |
|                           | 8. Functions            |
| D. Statistical entities   | 9. Queues               |
|                           | 10. Frequency tables    |
| E. Reference              | 11. Savevalues          |
|                           | 12. Matrix savevalues   |
| F. Chain entities         | 13. User chains         |
|                           | 14. Groups              |

Each of the 14 entities has associated with it what is known as a Standard Numerical Attribute (SNA). These SNA can be externally addressable by the user and they represent the status of the entity.

The following is a summary of what the different entities listed above are used for.

A. Blocks and Transactions

Blocks of different shapes are used to represent the different entities. In describing a physical system, a flow chart is constructed using appropriate blocks and putting on these blocks, suitable operand values. (See flow graph in Appendix B). There is a total of 43 different block types. The system is simulated by keeping track of all events that take place and an event is said to have occurred when transactions move from one block to another. A transaction in a GPSS programme can stand for a message in a communications system, a repairman at a gas station, a customer in a supermarket, a car at the car wash or assembly line, etc. The exact meaning accorded to the transaction depends on the system being simulated. In our research, a transaction in model segment-1 stood for a phone call, while in model segment-2, it represented a dynamic channel].

The blocks have two SNA that can be addressed externally and these are the total block count and the current block count. The total block count is the number of transactions that have gone through the block since the simulation began and the current block count represents the current number of transactions in the block. The coding format of blocks and

other entities is as follows:

1	2	8	19	72
	Location	Operation	Operands	
			A,B,C,D,E,F,G,	

The location field is used for an alpha numeric symbolic name that the user tags to the block or entity. For example, in our flowchart in Appendix B, we have named the cells as CEL 1-CEL 40. The first three positions of the alpha-numeric name must be alphabetic, and a maximum of five characters is allowed.

The operation field has a code word representing the subroutine that is to be done once a transaction enters the block. Examples are ADVANCE meaning hold the transaction for an amount of time specified by the operands A and B. The operands are the data input to the subroutine.

The transaction has four SNA and they are (i) the parameter number, (ii) the priority number, (iii) the transit time and (iv) the intermediate transit time. Every transaction is tagged with messages describing it. If the transaction represents a message package in a data communications system, then such information as the message length, destination, origin, etc. can be put in known parameter locations of the transaction. When this transaction enters a block in the system, the block can quickly find out all the information

about the transaction by testing any of the parameter values. Up to 127 levels of transaction priorities can be realized in GPSS/360.

#### B. Equipment Entities

As mentioned before, to represent single servers, facilities are used and pre-empting is allowed at the SEIZE blocks. When there is more than one server, then the storages are used. The actual number of servers involved is given to the system by specifying the capacity of the storage on a storage definition card. No pre-emption is allowed when using storages. There are four SNA associated with facilities and seven SNA for the storage. Once again Standard Numerical Attributes (SNA) are used to get some information about the status of an entity in the simulated system.

Logic switches are used to represent the on/off status or iddle/busy status, etc. When the logic switches are reset, their SNA is zero and when they are set, the SNA is 1.

#### C. Computational Entities

With the help of computational entities, one can build quite complex models. The relationships between different entities in the real system can be represented in the GPSS/360 model by using suitable SNA, of these entities, in describing the Arithmetic variable, Boolean variable or Functions. Then these computational entities are used as operands on the blocks

that describe the system. For example, if a transaction is to proceed in a model from one block to another only after certain conditions in the model are met, these governing conditions can be defined using any of the three computational entities. Then a TEST block can be used to see if the conditions in the system are what they should be, before the transaction is allowed to proceed in the model.

Before distribution functions can be constructed and defined to GPSS/360 for its use in executing the model, it is of paramount importance to know exactly how the GPSS/360 evaluates these functions. The exponential distribution was used in our model, and it will be explained here how we incorporated it into the GPSS/360 model.

The arrival rates of phone calls to the cells was assumed to be Poisson. Consequently, interarrival-time distribution of phone calls in the cells of the system was assumed to be exponential, with a known mean. Therefore at the GENERATE blocks (GENERATE blocks are the ones that schedule the arrival of transactions to the GPSS model) a sample had to be drawn from this exponential interarrival-time distribution and then added to the absolute clock of the GPSS simulator. A phone call was then scheduled to enter the system at this computed time. For example, if the absolute clock was 1000 time units since the simulation began, and the value drawn at random from the interarrival-time distribution was 150 time

units, then a phone call was scheduled to enter the system when the absolute clock was updated to 1500 time units.

A detailed explanation of how the interarrival-time sample was obtained will now be explained. The Poisson arrival rate can be shown to be given by the expression

$$P_k(t) = \frac{e^{-\lambda t} (\lambda t)^k}{k!} \quad k = 0, 1, 2, \dots \quad \text{--- (T.J.)}$$

where  $P_k(t)$  is the probability that exactly  $k$  arrivals will occur in the time interval duration  $t$ , and  $\lambda$  is the mean arrival rate of phone calls per unit time.

The assumptions used in deriving equation (T.J.) are:

- a) The probability that a phone call is initiated within a small time interval is proportional to size of the interval.
- b) The probability of two or more phone calls arriving during a small time interval is negligibly small.
- c) The interarrival times are independent of each other.

From equation (T.J.), the probability that no phone call will be initiated within time  $t$  is  $e^{-\lambda t}$  ( $k=0$ ) and therefore the probability of at least one phone call is

$$\hat{P}_1(t) = 1 - e^{-\lambda t} \dots \dots \dots \text{(H.K.)}$$

What we now need is the time  $t$  that will elapse before we introduce a phone call to the system.

Rearranging equation (H.K.) above gives  $e^{-\lambda t} = 1 - \hat{P}_1(t)$  and taking natural logarithms of both sides gives, after some obvious simplifications,

$$t = -\frac{1}{\lambda} (\log_e (1 - \hat{P}_1(t)))$$

where  $1/\lambda$  is the average interarrival time.  $\hat{P}_1(t)$  can take on values between 0 and 1 and this is what is known as the random number. In GPSS, this random number can take on values between 0.000000 and 0.999999.

Therefore the evaluation of  $t$  involves getting first a random number ( $RN_j$ ) and then evaluating  $-\log_e (1 - RN_j)$ . The  $j$  on  $RN_j$  is used to represent any one of the 8 available random number generators in GPSS/360.

In FORTRAN and other general computing languages, the natural logarithm function is built into the language and all the user does, is to call its name and it returns the function value (provided, of course, that he has supplied the argument). In GPSS/360, there are no built-in functions. One has to approximate the  $-\log_e(1 - RN_j)$ . Let  $y = -\log_e(1 - RN_j)$  where  $0 \leq RN_j \leq 1$  in the theory and in practice  $0 \leq RN_j \leq 0.999999$ . The above function has a general form as shown in the next page.

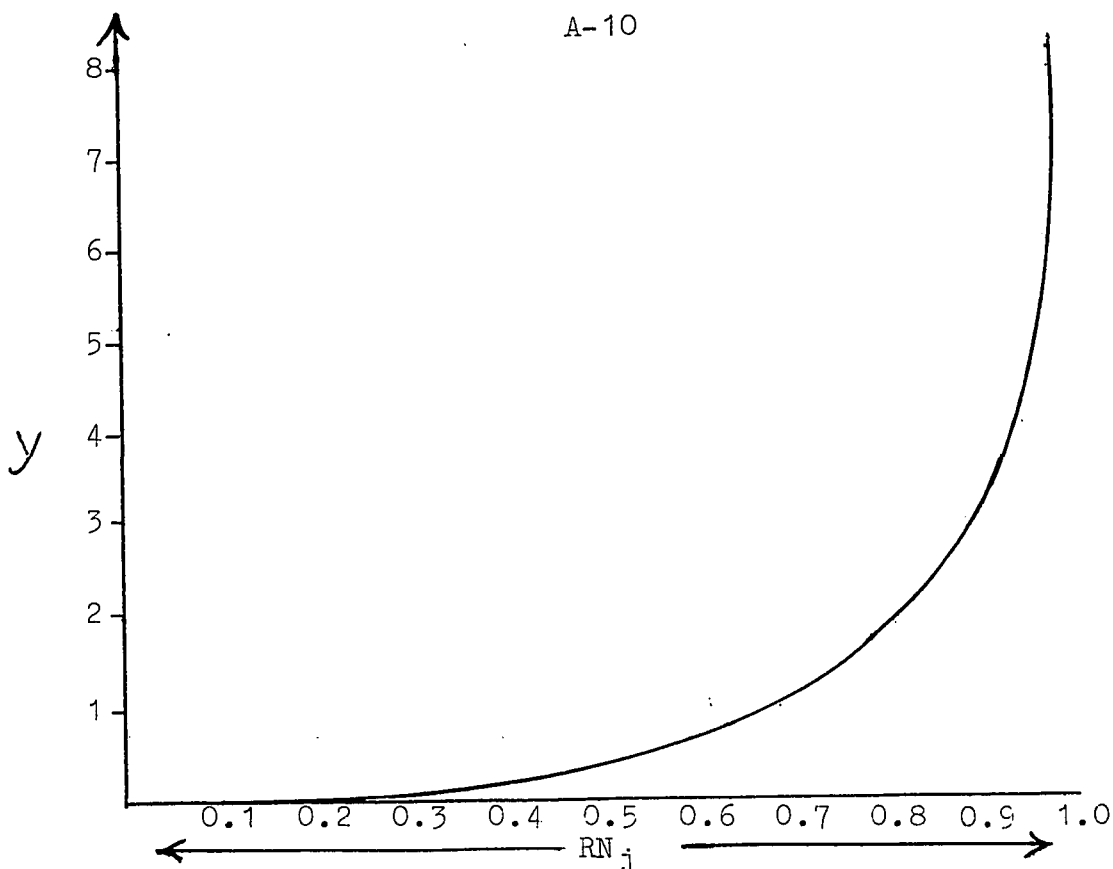

Therefore using any one of the random number generators, we define a continuous FUNCTION to approximate  $y$ . This defined function is symbolically name XPDIS (for exponential distribution and we used 23 line segments to approximate  $y$ . The 24 points together with their corresponding random numbers can be seen in Appendix C. Notice that theoretically, the maximum value of  $y$  is infinity, but in practice, it is only 13.8155 (corresponding to a returned maximum random number possible in GPSS/360 of 0.999999). But XPDIS function defined in Appendix C returns 8 as its maximum value. This means that there will be an error in the returned value of XPDIS in 0.0199 % of the time.

Assumption (b), used in the analytic derivation of the Poisson process, implied that the computed interarrival time

should not be zero. To compute the interarrival time at a GENERATE block, we supply the mean of the interarrival time as the A operand and the function, here symbolically named XPDIS, as the B operand. The returned value of XPDIS is multiplied by the supplied mean, AND THE RESULT ROUNDED TO THE NEAREST INTEGER VALUE. Therefore, a zero interarrival time value will be computed in all those cases where the returned value of XPDIS is less than the reciprocal of the supplied A value. For example, if the mean is 10 time units, the computed time to the next arrival will be zero whenever the returned value of XPDIS is less than 1/10. Observing the XPDIS function used in Appendix C, we find that it will return a value less than 1/50 in 2 per cent of the time (by inverse interpolation between the points 0, 0 and .1, .104). This is usually an acceptable error. In our model, we used values greater than 1000, for the operand A, at all GENERATE blocks that had the exponential function as their B operand.

A final point of concern when a Poisson arrival process is in effect, is the possible range of values of computed interarrival times. The mean is always multiplied by XPDIS values that range from 0 to 13.185 (in our case from 0 to 8) and therefore the largest computed interarrival times will be given by the mean times 8. For exponentially distributed functions, the variance is given by the square of the mean. Therefore, because of the wide variations possible due to the exponential function, relatively long simulations are

recommended in order to obtain representative results. The duration of our runs was at least 20 minutes in simulated time, with the first five minutes used to take the system to steady state. The five-minute figure was arrived at by simulating the system and taking "snapshots" of the system at regular intervals. We said to have attained system steady state, when the computed average blocking probability was independent of the instant when the snapshot was taken.

#### D. Statistical Entities

In order to gather information about the queues in a simulated system, one must use a special block, called the Queue block. Whenever a transaction enters this block, the seven SNA that are associated with Queues are updated. The seven SNA are :

1.  $Q_j$  = current contents of Queue  $j$
2.  $QM_j$  = maximum contents of Queue  $j$
3.  $QA_j$  = average contents of Queue  $j$
4.  $QC_j$  = total entries into Queue  $j$
5.  $QZ_j$  = zero entries into Queue  $j$
6.  $QT_j$  = average time/transaction in Queue  $j$
7.  $QX_j$  = average time/transaction in Queue  $j$ ,  
excluding zero entries.

The zero entries represent transactions that were not delayed at all before entering the next block, after the Queue block. For example, if a Queue block was placed ahead of a SEIZE block, so as to gather statistics about a Facility

(single server) utilization, if no Queue forms, then all transactions will be zero entries, because they suffered no delays before capturing the server. Consequently, there are two types of "waiting times" per transaction (or customer). The SNA  $QT_j$  is computed including transactions that did not have to wait and therefore is biased downward. The SNA  $QX_j$  excludes transactions that had zero waiting times in its computing of average waiting time per transaction.

The Table entity is used to gather frequency statistics. The variables entered in the table are supplied via a TABLE definition card. For example,

```

2      8      19
JOYCE  TABLE  P1, 1, 1, 41

```

tells the GPSS/360 programme that there is to be a table formed with entry variables of Parameter 1 ( A operand). The left-interval is to be 1 (B operand) and the width of intermediate intervals is to be 1 (C operand) and that there are 41 such frequency intervals (D operand). Then when a transaction enters the block: TABULATE JOYCE, : this transactions parameter 1 value is entered in the appropriate frequency interval of the Table Joyce.

#### E. Reference Entities

Savevalues are provided for transactions to communicate with each other. A savevalue is like a common location

(address) where useful and general information is kept. A transaction can always have access to information stored in a savevalue location. The savevalues are of two types, the array and matrix-oriented savevalues.

F. Chain Entities.

GPSS simulates systems by keeping track of events in their chronological order. It has two internal entities called the current events and future events chains. Events that are supposed to take place now are put on the current events chain in order of their priority classes. There is a scan phase that directs GPSS/360 to try and effect the movement of the transactions on the current events chain, one by one, beginning with a transaction with the highest priority. Transactions that can not be moved forward at this moment, because of a definite blocking condition in the next block, are made scan inactive and put on a delay chain. Transactions that can be moved forward are moved through as many blocks as possible, till either a blocking condition ismet, a command to re-start the scan is given or till the transaction leaves the system via a TERMINATE block.

In order to be able to control the sequence of events, the user is given two entities, namely, the user chains and groups. The user can put transactions on chains and retrieve them according to his own imposed conditions. We used the

concept of user chains in our model to keep inventory of all dynamic channels and where these dynamic channels were being used. A dynamic channel was removed from the chain (borrowed) only if it meet the interference conditions which were defined via use of the Boolean variables.

The group entity is used to classify the types of transactions or customers in a system. In our model, all dynamic channels belonged to one group numbered 45. The dynamic channels being used in each cell were also given a group number similar to their cell number. For example, all dynamic channels in use in cell number 5, also belonged to group number 5. Certain operations can be done on one or all members of a given group, through use of the REMOVE, SCAN, ALTER and EXAMINE blocks.

For a detailed discussion of GPSS/360, the reader can consult references 26 and 27.

A P P E N D I X     B

FLOW CHARTS OF GPSS

Table of Definitions

Time unit = 1 msec.

Transactions

Model Segment-1	calls from cells.
P1	contains cell number in system
P2	division between permanent channels and dynamic ones
P3	contains number of Fixed channel being used for the call
P4	all calls using borrowed channels have the number of dynamic channel they borrowed put in parameter 4
Model Segment-2	Dynamic channels, seeded by master channel via split block.
P1 - P40	These are used for indicating, for transactions on the Ring (user chain), where a borrowed channel is being used; i.e. if channel 50 is being used in cell #40, then P10 will have 50 as it is valued.
P46	contains division between Fixed 8 dynamic channel in matrix MTOCC.
P47	contains Serialization of parameter from Split block.
P48	contains channel numerical value.

P50 Contains cell number of transactions from Model Segment-1 that wants to borrow dynamic channel, from Model Segment-2.

Model Segment-3 Clock-Simulation timer

Model Segment-4 Transaction for effecting statistics print-outs at the desired time (not used in final runs).

Savevalues

- |    |  |
|----|--|
| 1  | Division between dynamic and permanent.  |
| 2. | Means of communicating between Segment-1 and Segment-2 for the transaction that is coming from Segment-1 and wishes to borrow dynamic channel. The cell where it comes from is in 2. |
| 4  | Contains the channel that has been found suitable for borrowing for the case at hand.  |
| 6  | For immediate communication. Has value of dynamic channel that was being used.   |
| 7  | For communication purposes. Contains identification number of the cell where the call originated.  |
| 8. | Contains number of dynamic channel that is going to be relieved by one of the fixed channels.  |
| 9  | Contains the (P3) Fixed channel number that is being reassigned (to replace a dynamic channel).  |

10	The call that is being reassigned gets the matrix returned from this savevalue.
11	Contains a zero.
12	Contains cell number.

Variables

1 - 9, 51-53, 58, 59, 60	Indicators to take me into the matrix, that has been optimally divided.
4	7200000 -- Timer for entire system.
5	120000
6	P3 - 2 * P3 for saying that channel is busy in its nominal cell.
7	2400000 -- Time for statistics output.
10 - 49	Contains information about Interference cell groups.

Boolean Variables

1 - 40	These are designed to give idea of the dynamic channel activity in each and every cell in system. For a 40-cell system, there are 40 interference cell groups, and they are defined by Variables 10-49.
--------	---

Tables

JOYCE	Calls that have been served.
FAILED	Calls that have been blocked.

Storages

1 - 40 Cells.  
TAT(49) Entire system statistics.

Chains

WAIT Where calls wait for dynamic channels to be found.  
LNUP Temporary chain used from Split block to assigning actual channel values to transactions.  
RING chain that keeps track of dynamic channels.

Groups

1 - 40 Group  $i$  ( $i = 1, 40$ ) Contains dynamic channels being used in cell  $i$ .  
45 Contains all dynamic channels being used in the system.

Switches

1 - 40 Informs in-coming calls whether there are any more Fixed channels available in the cell. If the switch is set, then the call is immediately transferred to DYN block, so as to borrow a dynamic channel. This feature saves on CPU execution time.

Functions

XPDIS This function is used in returning samples of computed interarrival times.

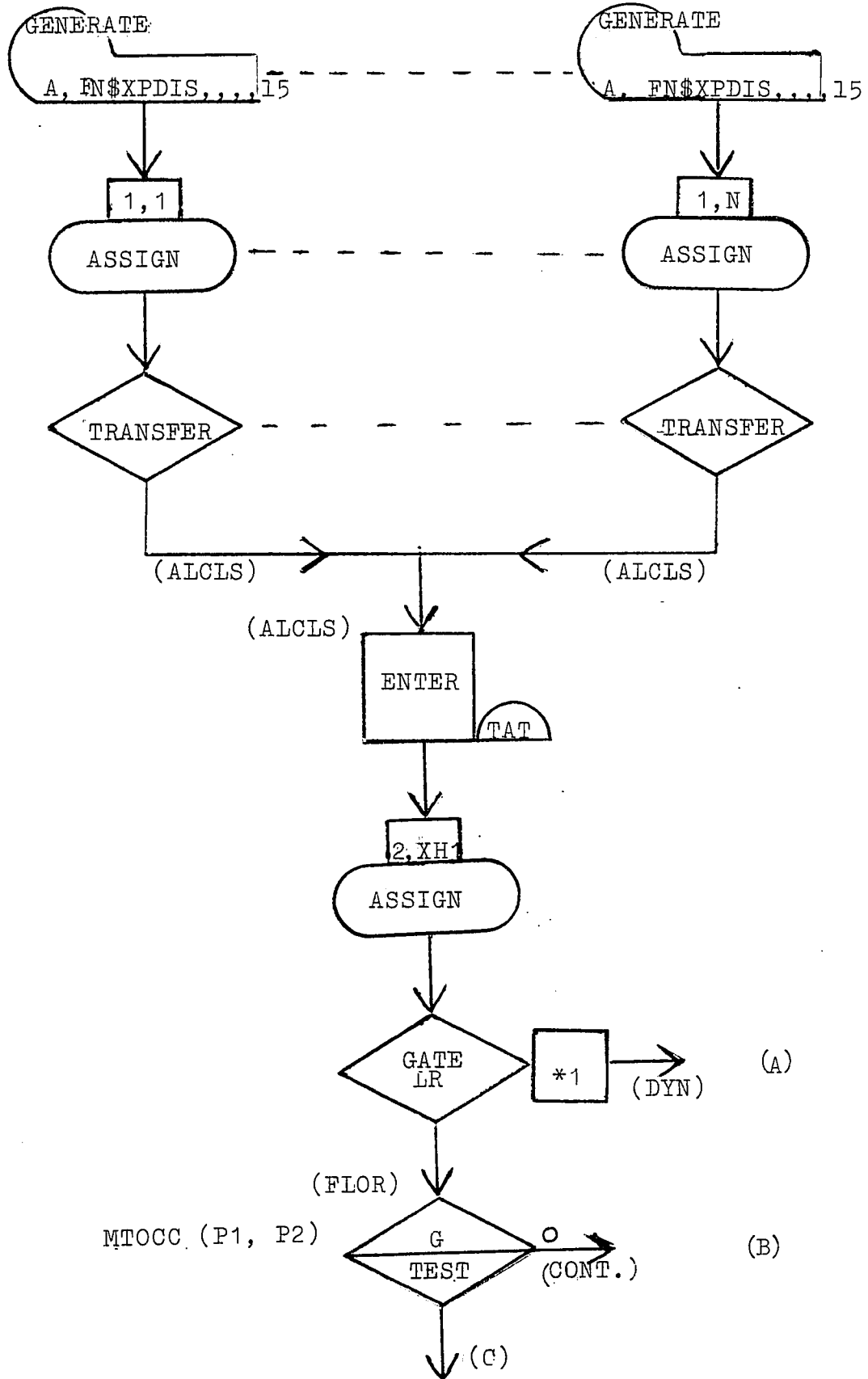

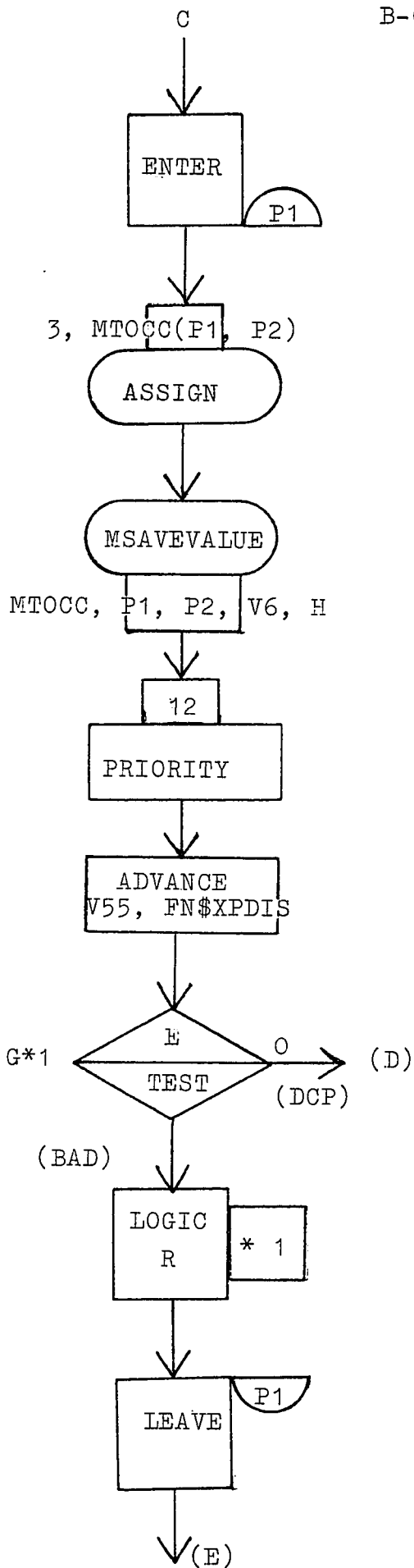

To enter in a particular cell P1

Eliminate channel from cell.

If there is a dynamic channel go to free it.

To ascertain that there are fixed channels.

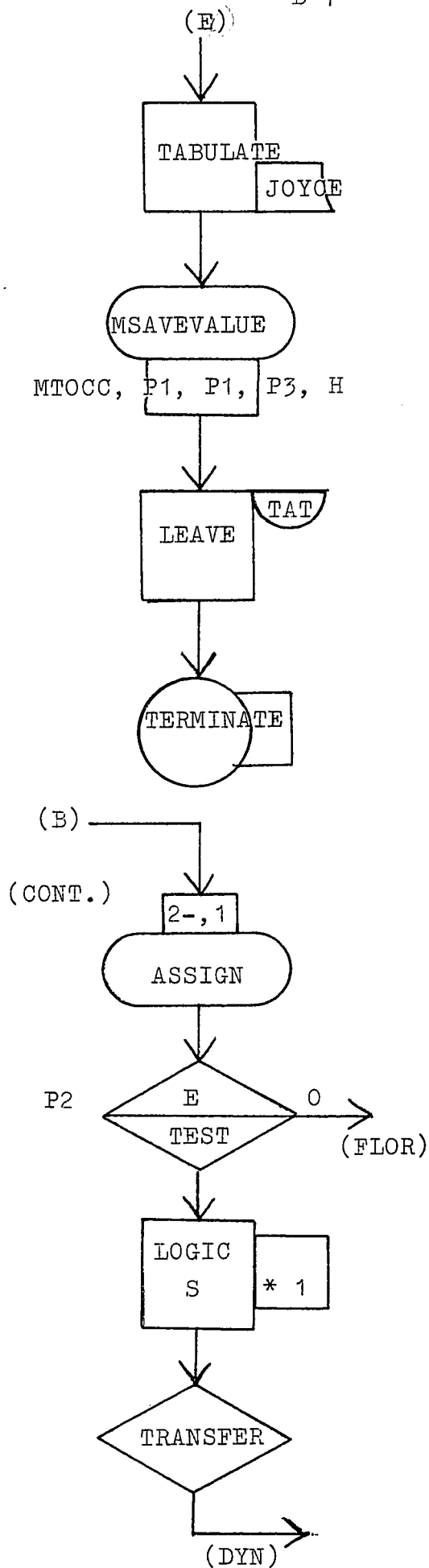

Tabulate calls that have been served.

Return the channel for next call.

Leave the system.

Decrease column number in search of a free channel.

See if all fixed channels are exhausted.

No more free channels.

Go to borrow dynamic channel.

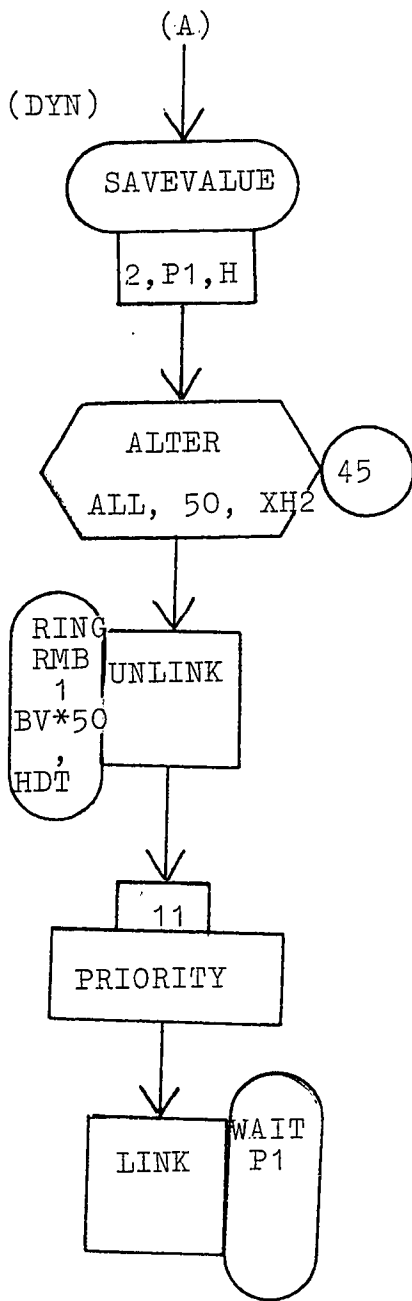

Origin of call is saved

All dynamic channels are informed which cell wants to borrow.

Unlink channel that satisfies the buffer constraints.

Make call wait for free channel

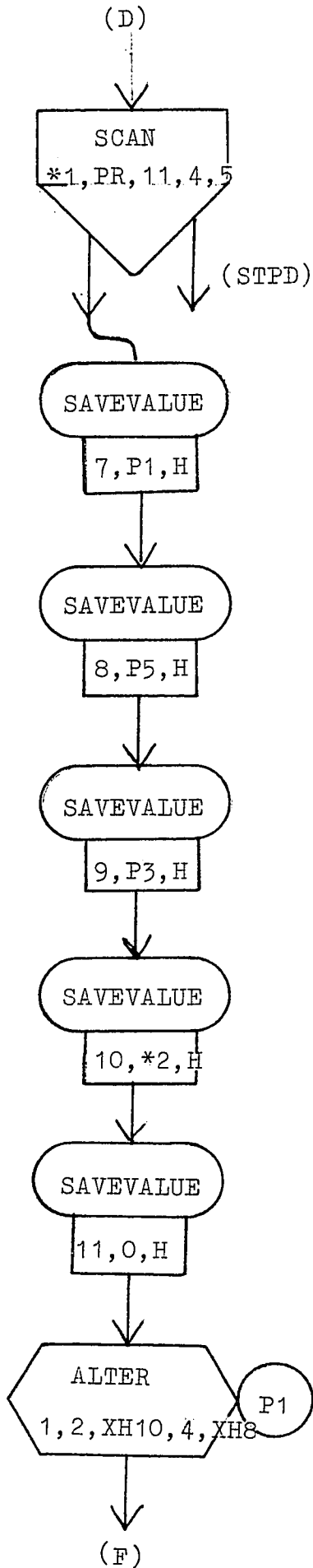

Calls that borrow dynamic channel have priority 11 and one of these calls has its borrowed channel put in P5 of passing transaction.

For communication. Cell origin saved.

Dynamic channel saved.

Fixed channel saved.

Store the value of column in matrix MTOCC.

Call, with borrowed dynamic channel.

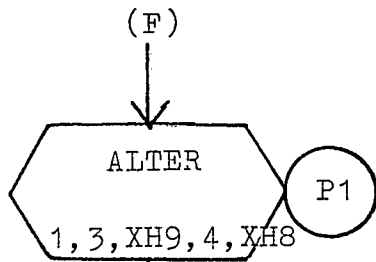

Alter channel being used in cell

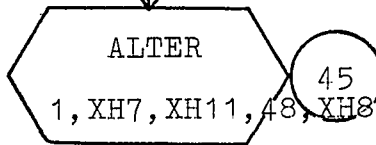

The call is ...  
no longer using dynamic channel

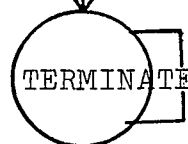
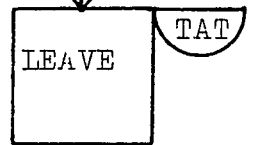
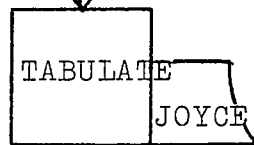
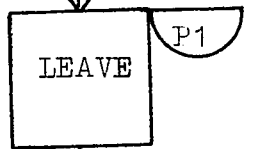
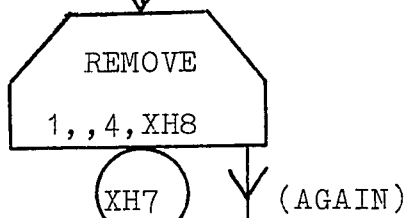

(AGAIN)

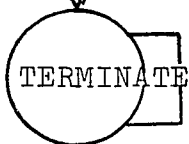
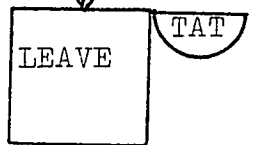
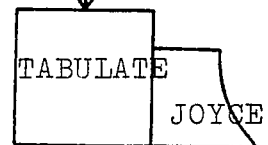
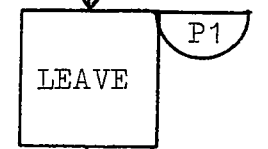

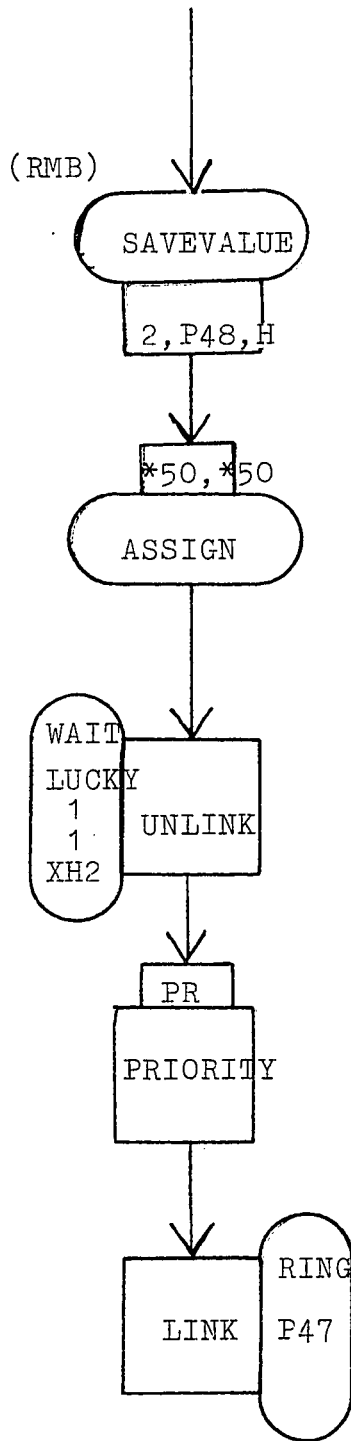

The channel to be borrowed is saved in 4.

Enter this in appropriate parameter value.

Go and use channel XH4

These ensure's continued servicing of call immediately

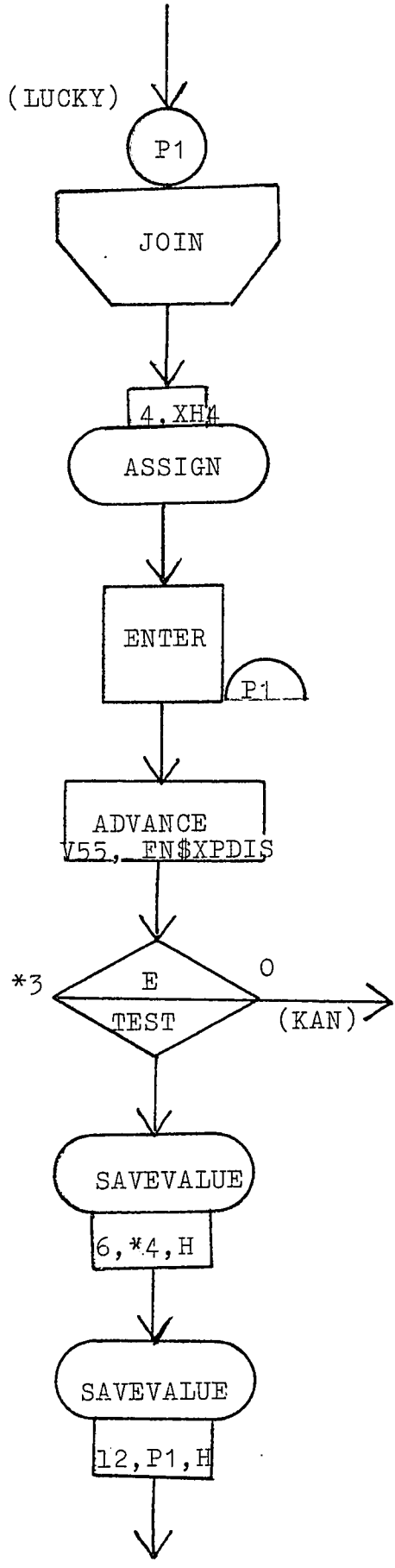

See if this is a re-assigned call. If it is, then go and see if there are any more calls using dynamic channel in this cell number.

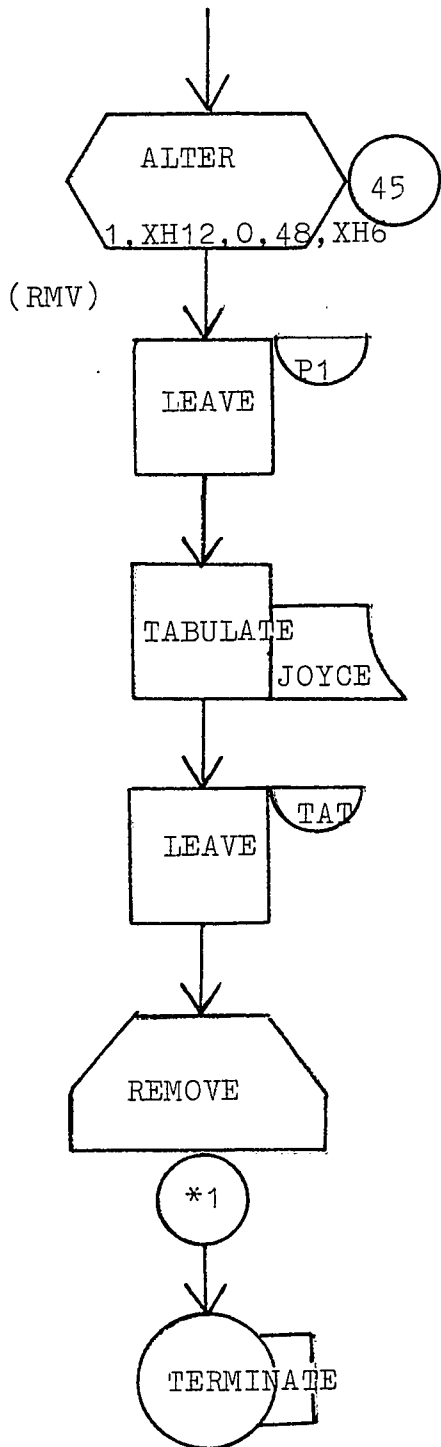

Unconditional remove from group.

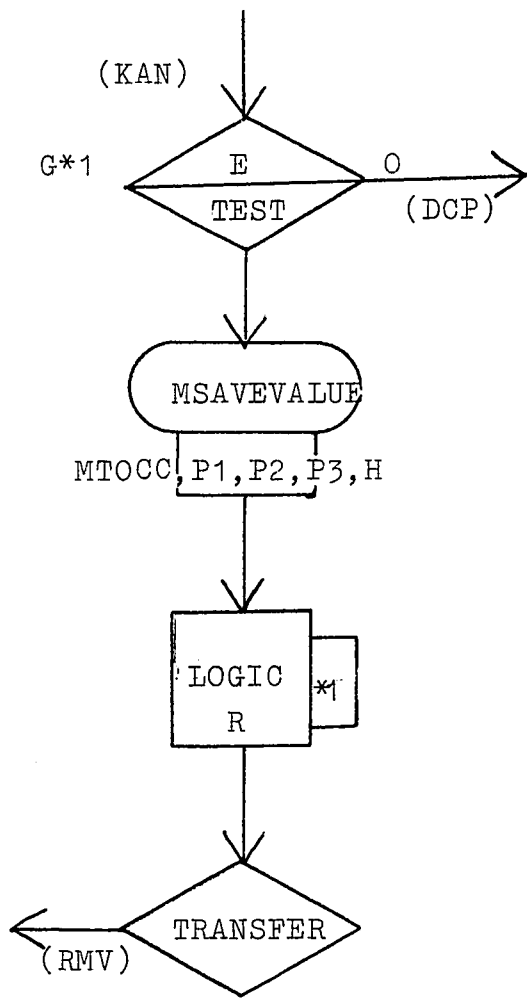

See if there are more dynamic channels in cell.

Return channel to cell.

Inform in-coming calls that now there are fixed channels available.

Go to remove from group.

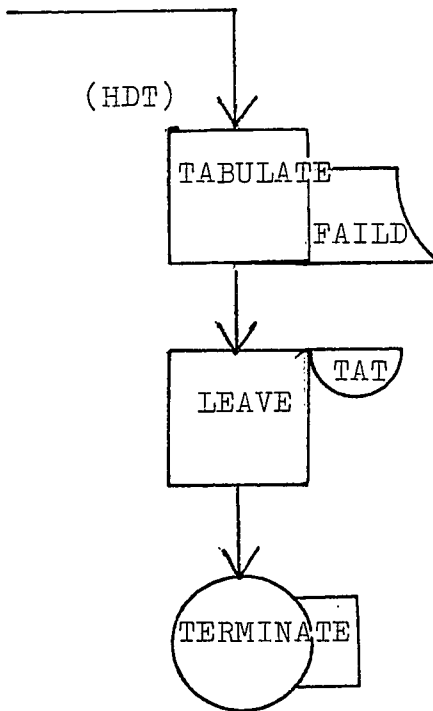

Tabulate blocked calls

MODEL SEGMENT-2

GENERATION AND CONTROL OF DYNAMIC CHANNELS

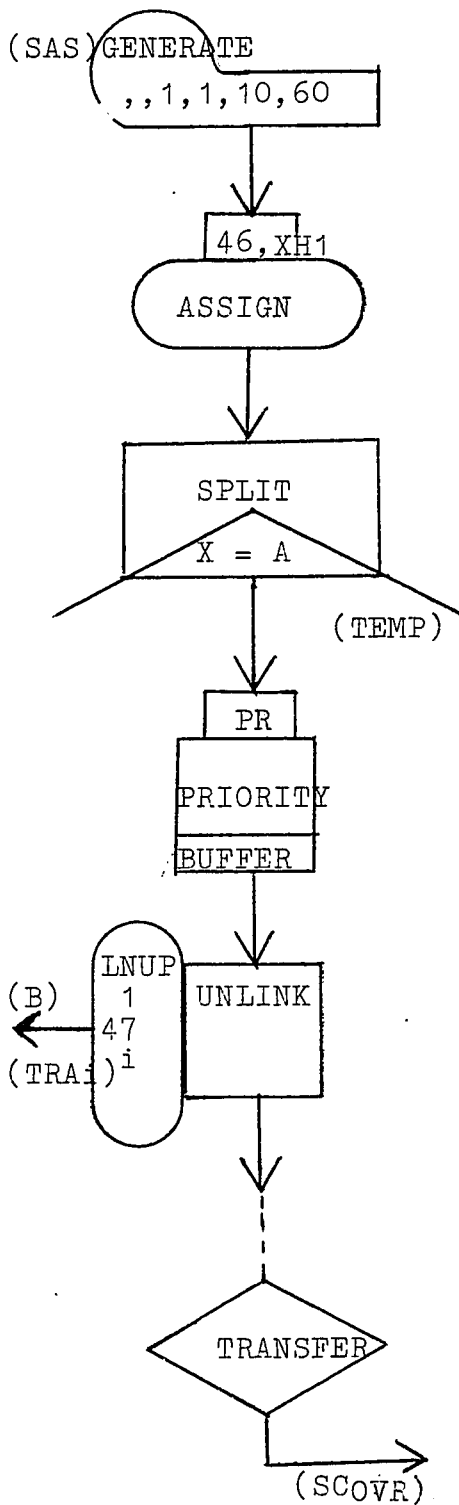

Creation of master seed of dynamic channels.

Split master channel into desired number of dynamic channels.

Re-start scan of current chain.

$i = -2, N,$  where  $N$  is the total number of dynamic channels in the system.

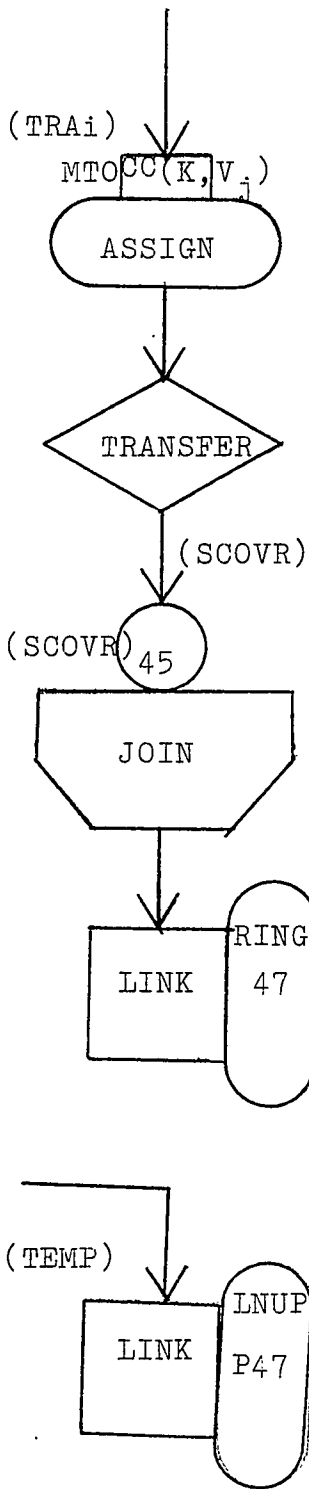

K is the matrix row number and  $V_j$  is the column index.

Join the group of dynamic channels

Put all dynamic channels on user chain RING.

Temporarily put on chain, till dynamic channel value is assigned to the transaction.

MODEL SEGMENT-3  
(TIMER SEGMENT)

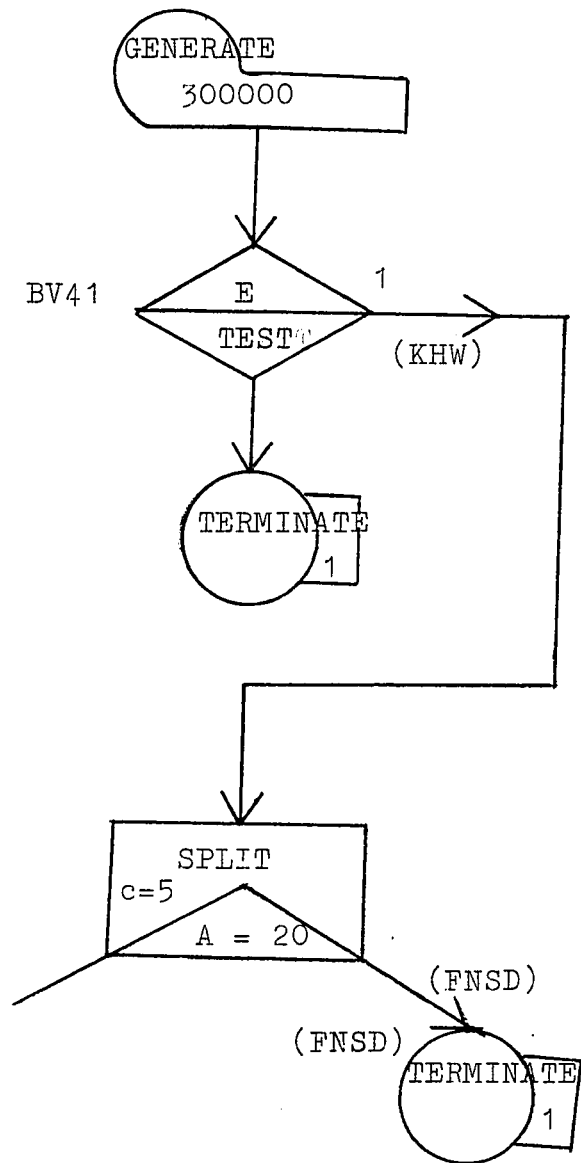

START	1, NP	No prints required at this point.
RESET	S49	Reset everything except the storage #49 = TAT
START	18	
END		

APPENDIX C

COMPUTER PROGRAMS

C-1

```
CREATE
REALLOCATE FAC,5,FUN,5,LOG,50,FMS,1,HMS,2,QUE,10,STD,50
REALLOCATE FSV,10,TAB,5,HSV,50,CHA,10,VAR,60,BVR,60,COM,101478
REALLOCATE GRP,50
SIMULATE
```

```
*
* MTOCC IS A MATTrix OF DIMENSION (40,60) .THE CELLS IN THE SYSTEM
* ARE REPRESENTED BY NUMBERS FROM 1 TO 40,CORRESPONDING WITH POWS OF
* THE MATTrix MTOCC.THE COLUMNS OF HET MATTrix SERVE TO INDICATE HOW
* MANY CHANNELS ARE ALLOWED FOR USE IN A CELL.
```

```
*
* THE FOLLOWING INITIAL CARDS ARE FOR ASSIGNING VALUES
* TO THE MATTrix MTOCC.
```

```
*
MTOCC MATRIX      H,40,60
INITIAL           XH1,20
INITIAL           MH$MTOCC(1,1),101
INITIAL           MH$MTOCC(2,1),111
INITIAL           MH$MTOCC(3,1),121
INITIAL           MH$MTOCC(4,1),131
INITIAL           MH$MTOCC(5,1),141
INITIAL           MH$MTOCC(6,1),151
INITIAL           MH$MTOCC(7,1),161
INITIAL           MH$MTOCC(8,1),171
INITIAL           MH$MTOCC(9,1),181
INITIAL           MH$MTOCC(1,2),102
INITIAL           MH$MTOCC(2,2),112
INITIAL           MH$MTOCC(3,2),122
INITIAL           MH$MTOCC(4,2),132
INITIAL           MH$MTOCC(5,2),142
INITIAL           MH$MTOCC(6,2),152
INITIAL           MH$MTOCC(7,2),162
INITIAL           MH$MTOCC(8,2),172
INITIAL           MH$MTOCC(9,2),182
INITIAL           MH$MTOCC(1,3),103
INITIAL           MH$MTOCC(2,3),113
INITIAL           MH$MTOCC(3,3),123
INITIAL           MH$MTOCC(4,3),133
INITIAL           MH$MTOCC(5,3),143
INITIAL           MH$MTOCC(6,3),153
INITIAL           MH$MTOCC(7,3),163
INITIAL           MH$MTOCC(8,3),173
INITIAL           MH$MTOCC(9,3),183
INITIAL           MH$MTOCC(1,4),104
INITIAL           MH$MTOCC(2,4),114
INITIAL           MH$MTOCC(3,4),124
INITIAL           MH$MTOCC(4,4),134
INITIAL           MH$MTOCC(5,4),144
INITIAL           MH$MTOCC(6,4),154
INITIAL           MH$MTOCC(7,4),164
INITIAL           MH$MTOCC(8,4),174
INITIAL           MH$MTOCC(9,4),184
INITIAL           MH$MTOCC(1,5),105
INITIAL           MH$MTOCC(2,5),115
INITIAL           MH$MTOCC(3,5),125
INITIAL           MH$MTOCC(4,5),135
INITIAL           MH$MTOCC(5,5),145
INITIAL           MH$MTOCC(6,5),155
INITIAL           MH$MTOCC(7,5),165
INITIAL           MH$MTOCC(8,5),175
INITIAL           MH$MTOCC(9,5),185
INITIAL           MH$MTOCC(1,6),106
INITIAL           MH$MTOCC(2,6),116
INITIAL           MH$MTOCC(3,6),126
```

INITIAL MH\$MTOCC(32,59),649  
 INITIAL MH\$MTOCC(33,59),599  
 INITIAL MH\$MTOCC(34,59),549  
 INITIAL MH\$MTOCC(35,59),599  
 INITIAL MH\$MTOCC(36,59),649  
 INITIAL MH\$MTOCC(37,59),549  
 INITIAL MH\$MTOCC(38,59),599  
 INITIAL MH\$MTOCC(39,59),549  
 INITIAL MH\$MTOCC(40,59),649  
 INITIAL MH\$MTOCC(10,60),550  
 INITIAL MH\$MTOCC(11,60),600  
 INITIAL MH\$MTOCC(12,60),550  
 INITIAL MH\$MTOCC(13,60),650  
 INITIAL MH\$MTOCC(14,60),550  
 INITIAL MH\$MTOCC(15,60),600  
 INITIAL MH\$MTOCC(16,60),550  
 INITIAL MH\$MTOCC(17,60),650  
 INITIAL MH\$MTOCC(18,60),550  
 INITIAL MH\$MTOCC(19,60),600  
 INITIAL MH\$MTOCC(20,60),650  
 INITIAL MH\$MTOCC(21,60),600  
 INITIAL MH\$MTOCC(22,60),550  
 INITIAL MH\$MTOCC(23,60),600  
 INITIAL MH\$MTOCC(24,60),650  
 INITIAL MH\$MTOCC(25,60),550  
 INITIAL MH\$MTOCC(26,60),650  
 INITIAL MH\$MTOCC(27,60),600  
 INITIAL MH\$MTOCC(28,60),550  
 INITIAL MH\$MTOCC(29,60),600  
 INITIAL MH\$MTOCC(30,60),650  
 INITIAL MH\$MTOCC(31,60),550  
 INITIAL MH\$MTOCC(32,60),650  
 INITIAL MH\$MTOCC(33,60),600  
 INITIAL MH\$MTOCC(34,60),550  
 INITIAL MH\$MTOCC(35,60),600  
 INITIAL MH\$MTOCC(36,60),650  
 INITIAL MH\$MTOCC(37,60),550  
 INITIAL MH\$MTOCC(38,60),600  
 INITIAL MH\$MTOCC(39,60),550  
 INITIAL MH\$MTOCC(40,60),650

\*  
 \*\* DEFINITION OF EQUIPMENT ENTITIES NOW FOLLOWS.  
 \*

TAT STORAGE S1-S40,50  
 EQU 49,S FORCE TAT TO BE SIGNED THE NO. 49  
 TAT STORAGE

\*  
 \*\* DEFINITION OF COMPUTATIONAL ENTITIES NOW FOLLOWS.  
 \*

XPDIS FUNCTION RN4,C24 EXPONENTIAL DISTRIBUTION FCN  
 0.0/.1,.104/.2,.222/.3,.355/.4,.509/.5,.69/.6,.915/.7,1.2/.75,1.38  
 .8,1.6/.84,1.83/.88,2.12/.9,2.3/.92,2.52/.94,2.81/.95,2.99/.96,3.2  
 .97,3.5/.98,3.9/.99,4.6/.995,5.3/.998,6.2/.999,7/.9998,8  
 1 VARIABLE XH1+1  
 2 VARIABLE XH1+2  
 3 VARIABLE XH1+3  
 4 VARIABLE XH1+4  
 5 VARIABLE XH1+5  
 6 VARIABLE XH1+6  
 7 VARIABLE XH1+7  
 8 VARIABLE XH1+8  
 9 VARIABLE XH1+9  
 51 VARIABLE XH1+10  
 52 VARIABLE XH1+11  
 53 VARIABLE XH1+12  
 58 VARIABLE XH1+13  
 59 VARIABLE XH1+14  
 60 VARIABLE XH1+15

10	VARIABLE	P1+P2+P3+P5+P6+P7
11	VARIABLE	P2+P9+P10+P3+P1+P7+P8
12	VARIABLE	P3+P10+P11+P12+P4+P1+P2
13	VARIABLE	P4+P3+P12+P13+P14+P5+P1
14	VARIABLE	P5+P1+P4+P14+P15+P16+P6
15	VARIABLE	P6+P7+P1+P5+P16+P17+P18
16	VARIABLE	P7+P8+P2+P1+P6+P18+P19
17	VARIABLE	P8+P21+P9+P2+P7+P19+P20
18	VARIABLE	P9+P22+P23+P10+P2+P8+P21
19	VARIABLE	P10+P23+P24+P11+P3+P2+P9
20	VARIABLE	P11+P24+P25+P26+P12+P3+P10
21	VARIABLE	P12+P11+P26+P27+P13+P4+P3
22	VARIABLE	P13+P12+P27+P28+P29+P14+P4
23	VARIABLE	P14+P4+P13+P29+P30+P15+P5
24	VARIABLE	P15+P5+P14+P30+P31+P32+P16
25	VARIABLE	P16+P6+P5+P15+P32+P33+P17
26	VARIABLE	P17+P18+P6+P16+P33+P34+P35
27	VARIABLE	P18+P19+P7+P6+P17+P35+P36
28	VARIABLE	P19+P20+P8+P7+P18+P36+P37
29	VARIABLE	P20+P38+P21+P8+P19+P37
30	VARIABLE	P21+P38+P39+P22+P9+P8+P20
31	VARIABLE	P22+P39+P40+P41+P23+P9+P21
32	VARIABLE	P23+P41+P42+P24+P10+P9+P22
33	VARIABLE	P24+P42+P43+P25+P11+P10+P23
34	VARIABLE	P25+P43+P44+P45+P26+P11+P24
35	VARIABLE	P26+P11+P25+P27+P12
36	VARIABLE	P27+P12+P26+P28+P13
37	VARIABLE	P28+P29+P13+P27
38	VARIABLE	P29+P30+P14+P13+P28
39	VARIABLE	P30+P31+P15+P14+P29
40	VARIABLE	P31+P32+P15+P30
41	VARIABLE	P32+P33+P16+P15+P31
42	VARIABLE	P33+P34+P17+P16+P32
43	VARIABLE	P34+P35+P17+P33
44	VARIABLE	P35+P36+P18+P17+P34
45	VARIABLE	P36+P37+P19+P18+P35
46	VARIABLE	P37+P20+P19+P36+P38
47	VARIABLE	P38+P39+P20+P37
48	VARIABLE	P39+P40+P20+P21+P38
49	VARIABLE	P40+P22+P21+P39
1	BVARIABLE	V10'E'0
2	BVARIABLE	V11'E'0
3	BVARIABLE	V12'E'0
4	BVARIABLE	V13'E'0
5	BVARIABLE	V14'E'0
6	BVARIABLE	V15'E'0
7	BVARIABLE	V16'E'0
8	BVARIABLE	V17'E'0
9	BVARIABLE	V18'E'0
10	BVARIABLE	V19'E'0
11	BVARIABLE	V20'E'0
12	BVARIABLE	V21'E'0
13	BVARIABLE	V22'E'0
14	BVARIABLE	V23'E'0
15	BVARIABLE	V24'E'0
16	BVARIABLE	V25'E'0
17	BVARIABLE	V26'E'0
18	BVARIABLE	V27'E'0
19	BVARIABLE	V28'E'0
20	BVARIABLE	V29'E'0
21	BVARIABLE	V30'E'0
22	BVARIABLE	V31'E'0
23	BVARIABLE	V32'E'0
24	BVARIABLE	V33'E'0
25	BVARIABLE	V34'E'0
26	BVARIABLE	V35'E'0
27	BVARIABLE	V36'E'0
28	BVARIABLE	V37'E'0

```

29 B VARIABLE V38'E'0
30 B VARIABLE V39'E'0
31 B VARIABLE V40'E'0
32 B VARIABLE V41'E'0
33 B VARIABLE V42'E'0
34 B VARIABLE V43'E'0
35 B VARIABLE V44'E'0
36 B VARIABLE V45'E'0
37 B VARIABLE V46'E'0
38 B VARIABLE V47'E'0
39 B VARIABLE V48'E'0
40 B VARIABLE V49'E'0
54 VARIABLE 7200000
55 VARIABLE 120000
56 VARIABLE P3-2*P3
57 VARIABLE 2400000
50 VARIABLE TC$JOYCE+TC$FAILD
41 B VARIABLE C1'LE'V54*V50'LE'6000 L/// CALLS TO BE SERVED

```

\*  
\* DEFINITION OF STATISTICAL ENTITIES NOW FOLLOWS  
\*

```

JOYCE TABLE P1,1,1,41
FAILD TABLE P1,1,1,41

```

\*  
\*  
\* NOW WE BEGIN TO GENERATE CALLS FROM THE CELLS OF THE SYSTEM.  
\* THERE ARE FOURTY CELLS AND THEREFORE FOURTY GENERATE BLOCKS ARE USED  
\* THE ASSIGN BLOCKS ARE USED TO IDENTIFY THE ORIGIN OF THE CALLS.  
\*

```

CEL1 GENERATE 6000, FN$XPDIS, . . . , 15
      ASSIN 1,1 IDENTIFY ORIGIN OF CALL
      TRANSFER ,ALCLS CALLS TO ENTER STORAGE OF THE WHOLE SYSTRN
CEL2 GENERATE 6000, FN$XPDIS, . . . , 15
      ASSIN 1,2 IDENTIFY CELL 2 AS ORIGIN
      TRANSFER ,ALCLS CALLS TO ENTER STORAGE OF THE WHOLE SYSTRN
CEL3 GENERATE 6000, FN$XPDIS, . . . , 15
      ASSIN 1,3
      TRANSFER ,ALCLS CALLS TO ENTER STORAGE OF THE WHOLE SYSTRN
CEL4 GENERATE 6000, FN$XPDIS, . . . , 15
      ASSIN 1,4
      TRANSFER ,ALCLS
CEL5 GENERATE 6000, FN$XPDIS, . . . , 15
      ASSIN 1,5 IDENTIFY CALL AS FROM 5
      TRANSFER ,ALCLS CALLS TO ENTER STORAGE OF THE WHOLE SYSTRN
CEL6 GENERATE 6000, FN$XPDIS, . . . , 15
      ASSIN 1,6 IDENTIFY CALL AS FROM CELL 6
      TRANSFER ,ALCLS CALLS TO ENTER STORAGE OF THE WHOLE SYSTRN
CEL7 GENERATE 6000, FN$XPDIS, . . . , 15
      ASSIN 1,7 IDENTIFY CALL AS FROM CELL 7
      TRANSFER ,ALCLS CALLS TO ENTER STORAGE OF THE WHOLE SYSTRN
CEL8 GENERATE 6000, FN$XPDIS, . . . , 15
      ASSIN 1,8 IDENTIFY CALL AS FROM CELL 8
      TRANSFER ,ALCLS CALLS TO ENTER STORAGE OF THE WHOLE SYSTRN
CEL9 GENERATE 6000, FN$XPDIS, . . . , 15
      ASSIN 1,9 IDENTIFY CALL AS FROM CELL 9
      TRANSFER ,ALCLS CALLS TO ENTER STORAGE OF THE WHOLE SYSTRN
CEL10 GENERATE 6000, FN$XPDIS, . . . , 15
      ASSIN 1,10 IDENTIFY CALL AS FROM CELL 10
      TRANSFER ,ALCLS CALLS TO ENTER STORAGE OF THE WHOLE SYSTRN
CEL11 GENERATE 6000, FN$XPDIS, . . . , 15
      ASSIN 1,11 IDENTIFY CALL AS FROM CELL 11
      TRANSFER ,ALCLS CALLS TO ENTER STORAGE OF THE WHOLE SYSTRN
CEL12 GENERATE 6000, FN$XPDIS, . . . , 15
      ASSIN 1,12 IDENTIFY CALL AS FROM CELL 12
      TRANSFER ,ALCLS CALLS TO ENTER STORAGE OF THE WHOLE SYSTRN
CEL13 GENERATE 6000, FN$XPDIS, . . . , 15

```

	ASSIGN	1,13
	TRANSFER	,ALCLS
CEL14	GENERATE	6000, FN\$XPDIS, . . . , 15
	ASSIGN	1,14
	TRANSFER	,ALCLS
CEL15	GENERATE	6000, FN\$XPDIS, . . . , 15
	ASSIGN	1,15
	TRANSFER	,ALCLS
CEL16	GENERATE	6000, FN\$XPDIS, . . . , 15
	ASSIGN	1,16
	TRANSFER	,ALCLS
CEL17	GENERATE	6000, FN\$XPDIS, . . . , 15
	ASSIGN	1,17
	TRANSFER	,ALCLS
CEL18	GENERATE	6000, FN\$XPDIS, . . . , 15
	ASSIGN	1,18
	TRANSFER	,ALCLS
CEL19	GENERATE	6000, FN\$XPDIS, . . . , 15
	ASSIGN	1,19
	TRANSFER	,ALCLS
CEL20	GENERATE	6000, FN\$XPDIS, . . . , 15
	ASSIGN	1,20
	TRANSFER	,ALCLS
CEL21	GENERATE	6000, FN\$XPDIS, . . . , 15
	ASSIGN	1,21
	TRANSFER	,ALCLS
CEL22	GENERATE	6000, FN\$XPDIS, . . . , 15
	ASSIGN	1,22
	TRANSFER	,ALCLS
CEL23	GENERATE	6000, FN\$XPDIS, . . . , 15
	ASSIGN	1,23
	TRANSFER	,ALCLS
CEL24	GENERATE	6000, FN\$XPDIS, . . . , 15
	ASSIGN	1,24
	TRANSFER	,ALCLS
CEL25	GENERATE	6000, FN\$XPDIS, . . . , 15
	ASSIGN	1,25
	TRANSFER	,ALCLS
CEL26	GENERATE	6000, FN\$XPDIS, . . . , 15
	ASSIGN	1,26
	TRANSFER	,ALCLS
CEL27	GENERATE	6000, FN\$XPDIS, . . . , 15
	ASSIGN	1,27
	TRANSFER	,ALCLS
CEL28	GENERATE	6000, FN\$XPDIS, . . . , 15
	ASSIGN	1,28
	TRANSFER	,ALCLS
CEL29	GENERATE	6000, FN\$XPDIS, . . . , 15
	ASSIGN	1,29
	TRANSFER	,ALCLS
CEL30	GENERATE	6000, FN\$XPDIS, . . . , 15
	ASSIGN	1,30
	TRANSFER	,ALCLS
CEL31	GENERATE	6000, FN\$XPDIS, . . . , 15
	ASSIGN	1,31
	TRANSFER	,ALCLS
CEL32	GENERATE	6000, FN\$XPDIS, . . . , 15
	ASSIGN	1,32
	TRANSFER	,ALCLS
CEL33	GENERATE	6000, FN\$XPDIS, . . . , 15
	ASSIGN	1,33
	TRANSFER	,ALCLS
CEL34	GENERATE	6000, FN\$XPDIS, . . . , 15
	ASSIGN	1,34
	TRANSFER	,ALCLS
CEL35	GENERATE	6000, FN\$XPDIS, . . . , 15
	ASSIGN	1,35
	TRANSFER	,ALCLS

C-6

```
CEL36 GENERATE 6000, FN$XPDIS, . . . , 15
      ASSIGN   1, 36
      TRANSFER , ALCLS
CEL37 GENERATE 6000, FN$XPDIS, . . . , 15
      ASSIGN   1, 37
      TRANSFER , ALCLS
CEL38 GENERATE 6000, FN$XPDIS, . . . , 15
      ASSIGN   1, 38
      TRANSFER , ALCLS
CEL39 GENERATE 6000, FN$XPDIS, . . . , 15
      ASSIGN   1, 39
      TRANSFER , ALCLS
CEL40 GENERATE 6000, FN$XPDIS, . . . , 15
      ASSIGN   1, 40
      TRANSFER , ALCLS
ALCLS ENTER TAT TO ENTER IN ONE OF THR 12 CELLS
      ASSIGN 2, XH1 P2 EQUATED TO MAX. NO. OF CHANN.
      GATE LR *1, DYN
```

```
*
*
* THIS PART OF THE PROGRAM SEARCHES FOR A FIXED CHANNEL TO ASSIGN
* TO THE CALL FOR USE. IF THERE ARE NO MORE FIXED CHANNELS, THE CALL IS
* ROUTED TO A SECTION IN THE PROGRAM THAT ASSIGNS DYNAMIC CHANNELS
* TO THE CALLS
*
```

```
FLOR TEST G MH$MTOCC(P1, P2), 0, CONT SEARCH FOR NEXT CHANNEL
      ENTER P1 TO ENTER IN A PARTICULAR CELL P1
      ASSIGN 3, MH$MTOCC(P1, P2)
      MSAVEVALUE MTOCC, P1, P2, V56, H ELIMINATE CHANN. FROM CELL -P3
      PRIORITY 12
      ADVANCE V55, FN$XPDIS
      TEST E G*1, 0, DCP IF THERE IS A DYNAMIC CHANN. FREE IT
BAD LOGIC R *1 TO ACERTAIN THAT THERE ARE STATIC CHANN.
      LEAVE P1
      TABULATE JOYCE
* WE GIVE IT A HIGHER PRIOR. SO THAT WE DONT LOSE NEW CALLS
      MSAVEVALUE MTOCC, P1, P2, P3, H FREQ. P3 IS RE-INSTATED IN CELL
      LEAVE TAT
      TERMINATE
STUPD TRANSFER , BAD JUST TO CHECK IF SCAN IS WORKING O.K.
```

```
*
* THIS SECTION LOOKS FOR AND ASSIGNS DYNAMIC CHANNELS TO THE CALLS.
*
```

```
DYN SAVEVALUE 2, P1, H ORIGIN OF CALL STORED
      ALTER 45, ALL, 50, XH2
      UNLINK RING, RMB, 1, BV*50, ., HDT
* CHANNEL PLEASE GET IT AND SEND IT TO RMB
      PRIORITY 11
      LINK WAIT, P1 MAKE THE CALL WAIT FOR DYN. CHANNEL.
HDT TABULATE FAILD
      LEAVE TAT
      TERMINATE
CONT ASSIGN 2, ., 1
      TEST E P2, 0, FLOR
      LOGIC S *1
      TRANSFER , DYN GO FOR HELP
* IN THE USUAL BIG PROGRAM THIS MEANS THAT NOW GO TO ROUTINE
* OF ASSIGNING TO THE CALL USING THE DYNAMIC CHANNELS
DCP SCAN *1, PR, 11, 4, 5, STUPD CALLS THAT BORROWED DYN. CHANN.
* HAVE PR=11, & ONE OF THESE CALLS HAS ITS BORROWED CHANN. PUT INPS
* OF PASSING TRANSACTION
      SAVEVALUE 7, P1, H FOR COMM. CELL ORIGIN SAVED
      SAVEVALUE 8, P5, H DYN. CHANN SAVED
      SAVEVALUE 9, P3, H NOMINAK CHANN. SAVED
      SAVEVALUE 10, *2, H STORE THE VALUE OF COLUMN MTOCC
      SAVEVALUE 11, 0, H
      ALTER P1, 1, 2, XH10, 4, XH8 CALL WITH BORROWED DYN. CHANN.
* CHANN. IS TOLD IN WHAT COLUMN OF MTOCC TO RETURN THE FIXED CHANN.
```

	ALTER	P1,1,3,XH9,4,XH8	ALTER CHANN. BEING USED IV CELL
	ALTER	45,1,XH7,XH11,48,XH8	
	REMOVE	XH7,1,4,XH8,AGAIN	NO LONGER USING DYN CHANN.
	LEAVE	P1	
	TABULATE	JOYCE	
	LEAVE	TAT	
AGAIN	TERMINATE		
	LEAVE	P1	
	TABULATE	JOYCE	
	LEAVE	TAT	
	TERMINATE		
RMB	SAVEVALUE	4,P48,H	
	ASSIGN	*50,*50	
	UNLINK	WAIT,LUCKY,1,1,XH2	GO & USE CHANXH4
	PRIORITY	PR	THIS ENSURES CONT-D SERVICING OF CALL IMMEDIATLY
	LINK	RING,P47	
LUCKY	JOIN	P1	
	ASSIGN	4,XH4	
	ENTER	P1	
	ADVANCE	V55,FN\$XPDIS	
	TEST E	*3,0,KAN	SEE IF THIS IS A REASSIGNED CALL
	SAVEVALUE	6,*4,H	
	SAVEVALUE	12,P1,H	
RMV	ALTER	45,1,XH12,0,48,XH6	
	LEAVE	P1	
	TABULATE	JOYCE	
	LEAVE	TAT	
	REMOVE	*1	UNCONDITIONAL REMOVE
	TERMINATE		
KAN	TEST E	G*1,0,DCP	SEE IF THERE ARE MORE DYN. CHANN. IN CELL
	MSAVEVALUE	MTOCC,P1,P2,P3,H	
	LOGIC R	*1	
	TRANSFER	.RMV	

\*  
\*  
\* MODEL SEGMENG-2, ASSIGNS TO THE SYSTEM THE NUMBER OF DYNAMIC CHANNELS  
\* THAT ARE TO BE USED IN THE CURRENT SIMULATION.  
\* ONE MASTER DYNAMIC CHANNEL IS CREATED AND THEN SPLIT INTO THE  
\* NUMBER OF DYNAMIC CHANNELS REQUIRED.  
\*

SAS	GENERATE	,,1,1,10,60	CREATOIN OF MASTER SEED FOR DYN CHNNS
	ASSIGN	46,XH1	
	SPLIT	44,TEMP,47,60	
	PRIORITY	PR,BUFFER	RESTART C SCAN OF CURP. CHAIN
	UNLINK	LNUP,TRA2,1,47,2	
	UNLINK	LNUP,TRA3,1,47,3	
	UNLINK	LNUP,TRA4,1,47,4	
	UNLINK	LNUP,TRA5,1,47,5	
	UNLINK	LNUP,TRA6,1,47,6	
	UNLINK	LNUP,TRA7,1,47,7	
	UNLINK	LNUP,TRA8,1,47,8	
	UNLINK	LNUP,TRA9,1,47,9	
	UNLINK	LNUP,TRA10,1,47,10	
	UNLINK	LNUP,TRA11,1,47,11	
	UNLINK	LNUP,TRA12,1,47,12	
	UNLINK	LNUP,TRA13,1,47,13	
	UNLINK	LNUP,TRA14,1,47,14	
	UNLINK	LNUP,TRA15,1,47,15	
	UNLINK	LNUP,TRA16,1,47,16	
	UNLINK	LNUP,TRA17,1,47,17	
	UNLINK	LNUP,TRA18,1,47,18	
	UNLINK	LNUP,TRA19,1,47,19	
	UNLINK	LNUP,TRA20,1,47,20	
	UNLINK	LNUP,TRA21,1,47,21	
	UNLINK	LNUP,TRA22,1,47,22	
	UNLINK	LNUP,TRA23,1,47,23	
	UNLINK	LNUP,TRA24,1,47,24	
	UNLINK	LNUP,TRA25,1,47,25	

```

UNLINK      LNUP,TRA26,1,47,26
UNLINK      LNUP,TRA27,1,47,27
UNLINK      LNUP,TRA28,1,47,28
UNLINK      LNUP,TRA29,1,47,29
UNLINK      LNUP,TRA30,1,47,30
UNLINK      LNUP,TRA31,1,47,31
UNLINK      LNUP,TRA32,1,47,32
UNLINK      LNUP,TRA33,1,47,33
UNLINK      LNUP,TRA34,1,47,34
UNLINK      LNUP,TRA35,1,47,35
UNLINK      LNUP,TRA36,1,47,36
UNLINK      LNUP,TRA37,1,47,37
UNLINK      LNUP,TRA38,1,47,38
UNLINK      LNUP,TRA39,1,47,39
UNLINK      LNUP,TRA40,1,47,40
UNLINK      LNUP,TRA41,1,47,41
UNLINK      LNUP,TRA42,1,47,42
UNLINK      LNUP,TRA43,1,47,43
UNLINK      LNUP,TRA44,1,47,44
UNLINK      LNUP,TRA45,1,47,45
TRANSFER    ,TRA1

```

\* A=MAX9# OF DYN CHANN. B=NEXT BLOCK "C=SERIA. PARAM. D=# OF PAR.  
\* THE ABOVE CARD MMUST BE CUSTOM MADE FOR EACH DIVISON

```

TEMP LINK      LNUP,P47
TRA1  ASSIGN   48,MH$MTOCC(1,V1)
      TRANSFER ,SCOV  GO TO QUEUE UP
TRA2  ASSIGN   48,MH$MTOCC(2,V1)
      TRANSFER ,SCOV  GO TO QUEUE UP
TRA3  ASSIGN   48,MH$MTOCC(3,V1)
      TRANSFER ,SCOV  GO TO QUEUE UP
TRA4  ASSIGN   48,MH$MTOCC(1,V2)
      TRANSFER ,SCOV  GO TO QUEUE UP
TRA5  ASSIGN   48,MH$MTOCC(2,V2)
      TRANSFER ,SCOV  GO TO QUEUE UP
TRA6  ASSIGN   48,MH$MTOCC(3,V2)
      TRANSFER ,SCOV  GO TO QUEUE UP
TRA7  ASSIGN   48,MH$MTOCC(1,V3)
      TRANSFER ,SCOV  GO TO QUEUE UP
TRA8  ASSIGN   48,MH$MTOCC(2,V3)
      TRANSFER ,SCOV  GO TO QUEUE UP
TRA9  ASSIGN   48,MH$MTOCC(3,V3)
      TRANSFER ,SCOV  GO TO QUEUE UP
TRA10 ASSIGN   48,MH$MTOCC(1,V4)
      TRANSFER ,SCOV  GO TO QUEUE UP
TRA11 ASSIGN   48,MH$MTOCC(2,V4)
      TRANSFER ,SCOV  GO TO QUEUE UP
TRA12 ASSIGN   48,MH$MTOCC(3,V4)
      TRANSFER ,SCOV  GO TO QUEUE UP
TRA13 ASSIGN   48,MH$MTOCC(1,V5)
      TRANSFER ,SCOV  GO TO QUEUE UP
TRA14 ASSIGN   48,MH$MTOCC(2,V5)
      TRANSFER ,SCOV  GO TO QUEUE UP
TRA15 ASSIGN   48,MH$MTOCC(3,V5)
      TRANSFER ,SCOV  GO TO QUEUE UP
TRA16 ASSIGN   48,MH$MTOCC(1,V6)
      TRANSFER ,SCOV  GO TO QUEUE UP
TRA17 ASSIGN   48,MH$MTOCC(2,V6)
      TRANSFER ,SCOV  GO TO QUEUE UP
TRA18 ASSIGN   48,MH$MTOCC(3,V6)
      TRANSFER ,SCOV  GO TO QUEUE UP
TRA19 ASSIGN   48,MH$MTOCC(1,V7)
      TRANSFER ,SCOV  GO TO QUEUE UP
TRA20 ASSIGN   48,MH$MTOCC(2,V7)
      TRANSFER ,SCOV  GO TO QUEUE UP
TRA21 ASSIGN   48,MH$MTOCC(3,V7)
      TRANSFER ,SCOV  GO TO QUEUE UP
TRA22 ASSIGN   48,MH$MTOCC(1,V8)
      TRANSFER ,SCOV  GO TO QUEUE UP

```

```

TRA23 ASSIGN      48,MH$MTOCC(2,V8)
      TRANSFER    ,SCOV  GO TO QUEUE UP
TRA24 ASSIGN      48,MH$MTOCC(3,V8)
      TRANSFER    ,SCOV  GO TO QUEUE UP
TRA25 ASSIGN      48,MH$MTOCC(1,V9)
      TRANSFER    ,SCOV  GO TO QUEUE UP
TRA26 ASSIGN      48,MH$MTOCC(2,V9)
      TRANSFER    ,SCOV  GO TO QUEUE UP
TRA27 ASSIGN      48,MH$MTOCC(3,V9)
      TRANSFER    ,SCOV  GO TO QUEUE UP
TRA28 ASSIGN      48,MH$MTOCC(1,V51)
      TRANSFER    ,SCOV  GO TO QUEUE UP
TRA29 ASSIGN      48,MH$MTOCC(2,V51)
      TRANSFER    ,SCOV  GO TO QUEUE UP
TRA30 ASSIGN      48,MH$MTOCC(3,V51)
      TRANSFER    ,SCOV  GO TO QUEUE UP
TRA31 ASSIGN      48,MH$MTOCC(1,V52)
      TRANSFER    ,SCOV  GO TO QUE UP
TRA32 ASSIGN      48,MH$MTOCC(2,V52)
      TRANSFER    ,SCOV  GO TO QUEUE UP
TRA33 ASSIGN      48,MH$MTOCC(3,V52)
      TRANSFER    ,SCOV  GO TO QUEUE UP
TRA34 ASSIGN      48,MH$MTOCC(1,V53)
      TRANSFER    ,SCOV  GO TO QUEUE UP
TRA35 ASSIGN      48,MH$MTOCC(2,V53)
      TRANSFER    ,SCOV  GO TO QUEUE UP
TRA36 ASSIGN      48,MH$MTOCC(3,V53)
      TRANSFER    ,SCOV  GO TO QUEUE UP
TRA37 ASSIGN      48,MH$MTOCC(1,V58)
      TRANSFER    ,SCOV  GO TO QUEUE UP
TRA38 ASSIGN      48,MH$MTOCC(2,V58)
      TRANSFER    ,SCOV  GO TO QUEUE UP
TRA39 ASSIGN      48,MH$MTOCC(3,V58)
      TRANSFER    ,SCOV  GO TO QUEUE UP
TRA40 ASSIGN      48,MH$MTOCC(1,V59)
      TRANSFER    ,SCOV  GO TO QUEUE UP
TRA41 ASSIGN      48,MH$MTOCC(2,V59)
      TRANSFER    ,SCOV  GO TO QUEUE UP
TRA42 ASSIGN      48,MH$MTOCC(3,V59)
      TRANSFER    ,SCOV  GO TO QUEUE UP
TRA43 ASSIGN      48,MH$MTOCC(1,V60)
      TRANSFER    ,SCOV  GO TO QUEUE UP
TRA44 ASSIGN      48,MH$MTOCC(2,V60)
      TRANSFER    ,SCOV  GO TO QUEUE UP
TRA45 ASSIGN      48,MH$MTOCC(3,V60)
      TRANSFER    ,SCOV  GO TO QUEUE UP

```

```

* THERE ARE AS MANY TRAI AS TGERE ARE DYN CHANNELLS
SCOV  JOIN      45
      LINK      RING,P47

```

```

* ALL THIS WAAS AN EXERCISE FOR ASSIGNING VALUES OF DYN CHANN.
* TO THE TRANSACTIONS

```

```

* MODEL SEGMENT-3, FOR CONTROLLING THE DURATION OF THE RUN.

```

```

SES  GENERATE    300000
      TEST E     BV41.1,KHW
      TERMINATE  1
KHW  SPLIT      20,FNSD,5
FNSD TERMINATE  1
      START     1,NP
      RESET     S49
      START     18.,,1

```

```

      REDUCE CLOCK TO ZERO NOW
      NO PRINTS REQUIERD AT THIS POINT
      RESET EVERYTHING EXCEPT THE STORAGE #49

```

V I T A E

NAME: Tomson Joe Kahwa

DATE AND PLACE  
OF BIRTH: Hoima, Uganda, 1948

EDUCATION: B. A. Sc. (Electrical Engineering)  
May 1975  
University of Ottawa,  
Ottawa, Ontario