

TABLE OF CONTENTS

	PAGE
LIST OF TABLES	1
LIST OF FIGURES	11
ABSTRACT	1
ACKNOWLEDGEMENT	2
INTRODUCTION	3
LITERATURE SURVEY	5
THEORY	8
REPRESENTATION OF COLUMN DYNAMICS	12
COMPOSITION CONTROL SCHEMES	15
SIMULATION PROCEDURE	25
RESULTS	30
SUMMARY OF RESULTS	74
ANALYSIS OF RESULTS	78
DISCUSSION OF RESULTS	82
CONCLUSIONS	88
NOMENCLATURE	89
REFERENCES	91
APPENDIX - A	95
APPENDIX - B	103
APPENDIX - C	118

LIST OF TABLES

TABLE	PAGE
1. SUMMARY OF RESULTS	75
2. RECOMMENDED MANIPULATIVE VARIABLES FOR TOP PRODUCT COMPOSITION CONTROL	79
3. RECOMMENDED MANIPULATIVE VARIABLES FOR BOTTOM PRODUCT COMPOSITION CONTROL	79
4. OPTIMUM SENSOR LOCATIONS FOR PRODUCT COMPOSITION CONTROL	81
5. OPTIMUM CONTROL CONFIGURATIONS FOR PRODUCT COMPOSITION CONTROL	81

LIST OF FIGURES

FIGURE	PAGE
1. BLOCK DIAGRAM OF A FEEDBACK CONTROL SYSTEM	10
2. BLOCK DIAGRAM OF A FEEDFORWARD PLUS FEEDBACK CONTROL SYSTEM	11
3. CONTROL SCHEME USING REFLUX RATE MANIPULATION TO EFFECT CONTROL	16
4. FEEDBACK CONTROL OF TOP PRODUCT COMPOSITION BY REFLUX RATE	17
5. FEEDBACK PRODUCT COMPOSITION CONTROL BY REFLUX RATE	17
6. FEEDBACK PRODUCT COMPOSITION CONTROL BY REBOIL VAPOUR RATE	19
7. FEEDBACK PRODUCT COMPOSITION CONTROL BY REBOIL VAPOUR RATE	19
8. FEEDFORWARD PLUS FEEDBACK CONTROL OF TOP PRODUCT COMPOSITION BY REFLUX RATE	21
9. FEEDFORWARD PLUS FEEDBACK PRODUCT COMPOSITION CONTROL BY REFLUX RATE	21
10. FEEDFORWARD PLUS FEEDBACK CONTROL OF TOP PRODUCT COMPOSITION BY REBOIL VAPOUR RATE	23

FIGURE		PAGE
11.	FEEDFORWARD PLUS FEEDBACK PRODUCT COMPOSITION CONTROL BY REBOIL VAPOUR RATE	23
12 to 51.	RESULTS	31 to 73
52 to 57.	COMPARISON OF GERSTER'S DATA WITH THE MODEL USED IN THIS WORK	97 to 102
58 to 69.	STABILITY RANGE OF FEEDBACK CONTROL SCHEMES	106 to 117
70 to 80.	ANALOG COMPUTER CIRCUITS	119 to 129

ABSTRACT

The transient behaviour of a binary distillation column was represented by means of transfer functions based on the experimental data reported by Gerster et al (20) for a ten-plate pilot column. An analog computer was used to simulate feedback and instantaneous feedforward plus feedback composition control schemes, using manipulation of reflux rate or reboil vapour rate to effect control. An abrupt 5 mole % step change in the feed composition was considered to be the only disturbance entering the column.

Minimisation of the maximum deviation and offset of product composition from its initial steady state was used as the criterion to evaluate all the control schemes. Top product composition was best controlled by manipulation of the reflux rate. Bottom product composition was best controlled by manipulation of the reboil vapour rate when the sensor was placed below the feed plate.

Best top product composition control by both feedback and instantaneous feedforward plus feedback control schemes was achieved by manipulation of the reflux rate with the sensor on plate 7. Best bottom product composition control by both feedback and instantaneous feedforward plus feedback control schemes was achieved by manipulation of the reboil vapour rate with the sensor on plate 3.

ACKNOWLEDGEMENT

The author wishes to thank Dr. R.K. Wood, the director of this work, for his advice, guidance and inspiration throughout the course of this project.

Financial assistance from the National Research Council under Research Grant No. A-1944 and from the Department of Chemical Engineering during the academic years 1965/1966 and 1966/1967 is gratefully acknowledged.

The author would also like to thank his parents, without whose encouragement and support this work might never have been undertaken.

INTRODUCTION

Continuous process plants, operated on a very large scale, are very common in the chemical and petroleum industries. Economic considerations demand products of highly specified quality. The maintenance of specified qualities in output streams in spite of disturbances in the input streams is the most common problem in process control within these industries.

Continuous distillation is frequently encountered in chemical and petroleum processing. The objective is to separate feed streams of known composition into two or more product streams whose compositions are specified within close tolerances. If disturbances in input streams occur, control action is necessary to maintain the product stream compositions within the specifications.

Gerster et al (20) have reported transient data for a ten-plate column separating acetone from benzene and have shown that the dynamics of the column can be represented by the linear model suggested by Lamb, Pigford and Rippen (19). Second order transfer functions were established from the data of Gerster et al (20). Transfer functions representing column dynamics, along with those representing ideal controllers, control valves, and the reboiler were used to simulate various control schemes on an analog computer.

This work considers three control schemes when the only

disturbance entering the column is an abrupt 5 mole % change in the feed composition. Two of the schemes were feedback control and instantaneous feedforward plus feedback control with variable sensor locations using either changes in reflux or reboil vapour rate as the manipulative variable to effect control. The third scheme investigated was an instantaneous feedforward plus feedback scheme which ensured that no offset would occur in the composition of either the top or bottom product streams at the new steady state.

The objectives of this work were:

- 1) To investigate whether product stream compositions could be more closely controlled by manipulating the reflux rate or the reboil vapour rate.
- 2) To find the optimum sensor locations for the control schemes considered.

LITERATURE SURVEY

In order to summarise the extensive literature on the subject of binary distillation column dynamics and control, several excellent review articles have been published. Archer and Rothfus (2) traced the development of column dynamics and control from its beginnings in the mid-1940's to 1961 by listing the references for the most important work done in this period. In 1963 Slotboom et al (28) presented a survey on the application of automatic control in the chemical industry with specific references to distillation column dynamics and control. Also in 1963, Gould (12) published a review article in which he pointed out the shortcomings of results then available and also made suggestions as to where future research might be most profitable. An extensive bibliography on current research is available by consulting the recent annual review articles by Williams (36, 37, 38, 39).

Interest in the dynamics of distillation columns dates back to the mid-1940's when the main motivation was to estimate start-up times. It was soon realised, however, that the art of automatic control, as it was known then, could be greatly improved if accurate dynamic characterisation of the column between steady states were possible. The major work done in this field up to 1961 is summarised by Archer and Rothfus (2). Though some experimental evidence supported many of the proposed models, few were extensively tested. The most thoroughly

tested model, proposed by Rosenbrock (25, 27), and tested by Armstrong and Wilkinson (3), showed better agreement at long times than at short times after the disturbance had been introduced.

Two more recent models have been extensively tested on experimental columns. One model, proposed by Huckaba et al (16, 17), uses a digital computer to solve the equations representing the model. The other model, proposed by Lamb, Pigford, and Rippen (19) and tested by Gerster et al (4, 5, 20, 21, 22, 29), uses linear perturbation techniques to simplify the equations that describe the dynamic behaviour of the column. The perturbation equations were then solved on an analog computer. Both models have been found to be in good agreement with experimental results.

A large number of papers have been published dealing with the theoretical and practical aspects of binary distillation column control. The review papers by Archer and Rothfus (2), Gould (12), and Williams (36, 37, 38, 39) summarise the most important work. Despite the existing voluminous literature, little attention has been devoted to the problem of selecting the optimum sensor location for top and/or bottom product composition control. Tivy (30), Pyle (23), Boyd Jr. (7), and Anisimov (1) suggest that the sensing element should be installed on the plate where the concentration gradient is a maximum. Buckley (8), Izawa and Morinaga (18), and Williams et al (33, 34, 35) suggest that for minimum variation in top product com-

position, the sensing element should be installed as near the top as possible, provided that the sensor dead time is small. Rosenbrock (26), based upon the criterion of a minimum in a disturbance function "D", suggested another possible location for the sensing element. Due to the difficulty of solving the equations describing a distillation column under control, time-domain evidence as to what effect variation of the control point has on the controllability of the column has not been forthcoming. It also has not been established whether there is any dynamic advantage to using reflux rate or reboiler vapour rate manipulation to effect control.

THEORY

Lamb, Pigford and Rippen (19) have presented a linear model for the characterisation of the dynamics of a binary distillation column between steady states. Gerster et al (4, 5, 20, 21, 22, 29) have tested this model using a ten-plate experimental column to separate a mixture of acetone and benzene. They introduced changes in the feed composition of between 6.5 and 16.7 mole %, changes in feed flow rate between 17.6% and 54.0%, changes in reflux rate between 12.1% and 54.0%, and changes in vapour boilup rate between 5.0% and 6.72%, one at a time, into the column and recorded the resulting changes in composition throughout the column as a function of time. It was found that experimental results for small disturbances were in good agreement with the proposed model.

If it is known a priori that a column's dynamic response can be characterized by a linear model and if experimental data of dynamic tests are available, then a much simpler, if empirical, method of characterizing the dynamics of the column is possible. Transfer functions can be established to relate changes in feed composition to changes in composition of the liquid on the plates and of the products. Similarly, the effect of changes in reflux rate and reboil vapour rate can be related to composition changes throughout the column. It is thus possible to represent the dynamics of the distil-

lation column in a form suitable for the study of control schemes. This is the approach followed in this work using the data of Gerster et al (20).

Two classical control schemes were studied in this work. A general feedback control scheme, shown in Figure 1, was investigated because this is the most common approach to column control. Instantaneous feedforward plus feedback control, shown in Figure 2, was investigated because it permits closer control than feedback control alone, and yet is easy to implement with standard commercial controllers.

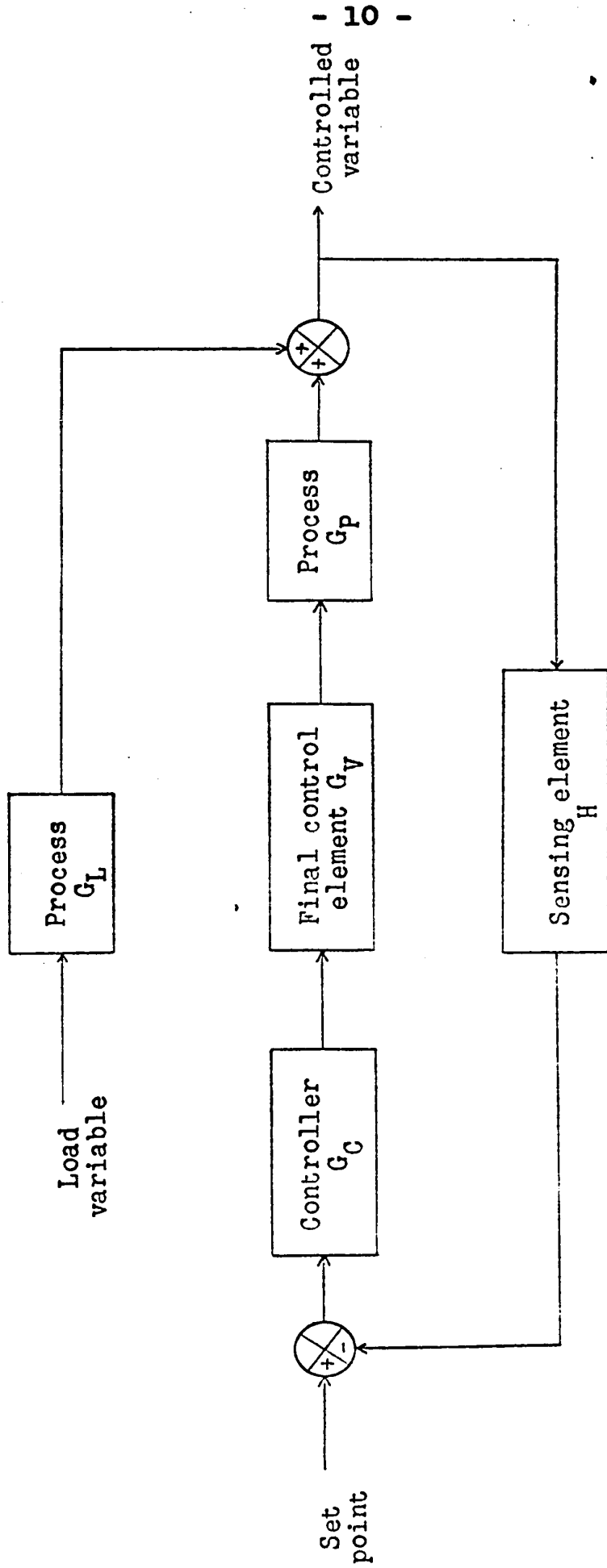

Figure 1. Block diagram of a feedback control system

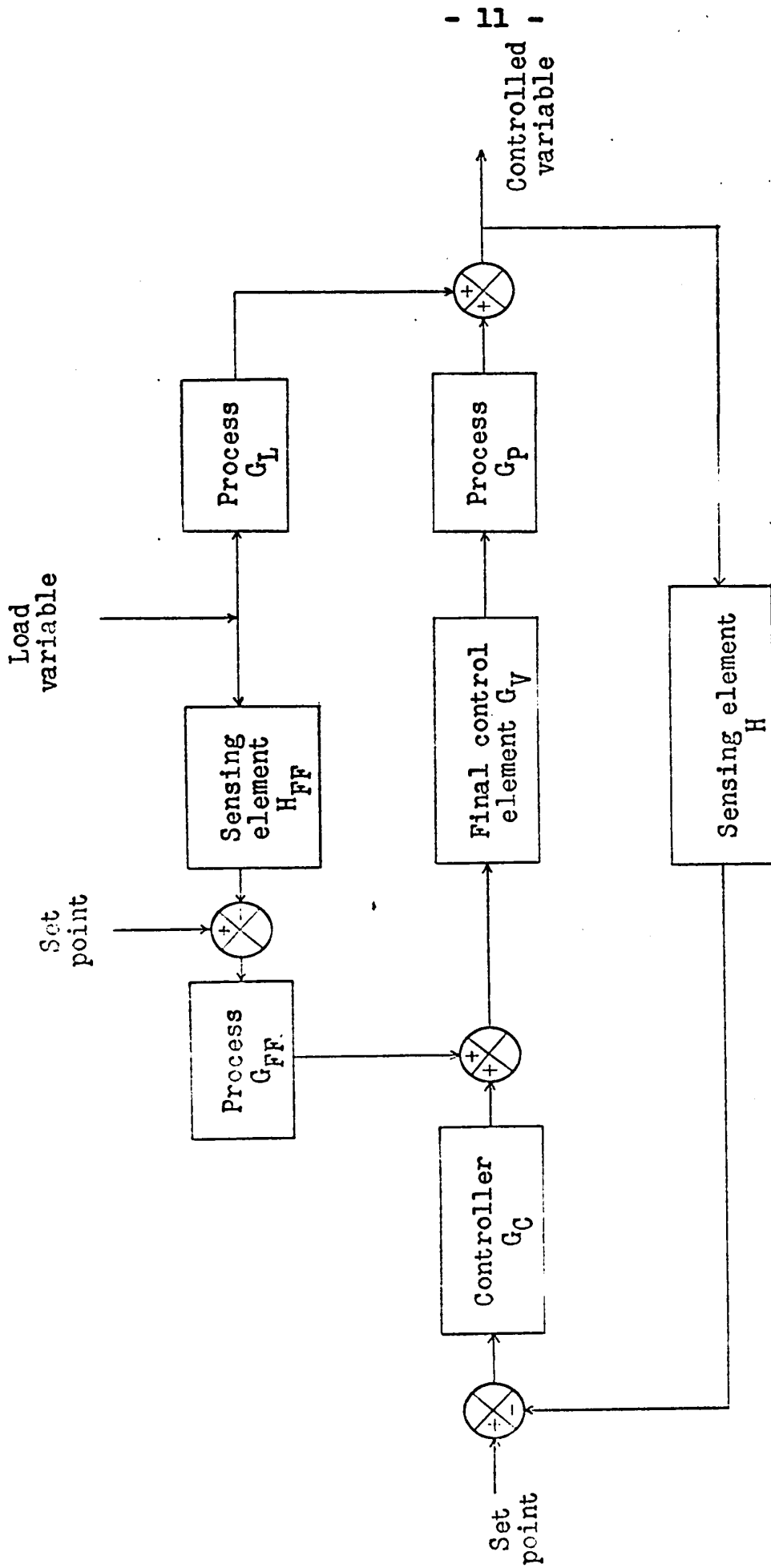

Figure 2. Block diagram of a feedforward plus feedback control system

REPRESENTATION OF COLUMN DYNAMICS

The dynamic data reported by Gerster et al (20) was normalized and plotted as fractional change in composition vs. time. Second order transfer functions were curve fitted by sight with emphasis on a good fit to the data at short times rather than at longer times in the cases where a compromise was necessary. Fu (11) shows most of these plots in his thesis. The additional plots needed for this work appear in Appendix A. A separate calculation established the correct gain for each transfer function such that the final steady state values of the variables were satisfied. Gains were defined as :

gain = change in output variable/change in input variable

with all time constants expressed in minutes. All composition and flow variables are perturbation quantities. The steady state values of these variables are tabulated in Appendix A. The following transfer functions were used to represent the dynamics of the distillation column :

$$G_{DF} = 0.58/(7.55s+1)(0.15s+1)$$

$$G_{GF} = 1.17/(7.8s+1)(0.65s+1)$$

$$G_{TF} = 1.67/(6.6s+1)(0.6s+1)$$

$$G_{3F} = 1.94/(7.9s+1)(0.1s+1)$$

$$G_{1F} = 1.125/(9.2s+1)(2.5s+1)$$

$$G_{4F} = 0.808/(8.0s+1)(2.5s+1)$$

$$G_{2F} = 0.273/(5.5s+1)(4.5s+1)$$

$$G_{9V} = 0.582 / (7.2s + 1)(2.2s + 1)$$

$$G_{7V} = 0.80 / (7.95s + 1)(0.60s + 1)$$

$$G_{3V} = 1.22 / (7.56s + 1)(1.14s + 1)$$

$$G_{1V} = 1.30 / (7.0s + 1)(4.5s + 1)$$

$$G_{4V} = 0.627 / (11.0s + 1)(6.0s + 1)$$

$$G_{2R} = 0.311 / (8.2s + 1)(0.1s + 1)$$

$$G_{9R} = 0.596 / (6.65s + 1)(0.27s + 1)$$

$$G_{7R} = 0.909 / (8.0s + 1)(0.46s + 1)$$

$$G_{3R} = 1.015 / (8.25s + 1)(0.65s + 1)$$

$$G_{1R} = 0.833 / (7.95s + 1)(3.25s + 1)$$

$$G_{4R} = 0.258 / (75s^2 + 10s + 1)$$

Other transfer functions used were:

Reboiler: $G_R = \Delta V / \Delta \text{steam rate} = K_R / 0.5s + 1$

Sensing element: $H = \Delta \text{voltage} / \Delta \text{composition} = K_H / s + 1$

Control valves: The valves were considered to have linear characteristics and to have a negligible response time to a pneumatic input signal. Hence the valves, along with the current to air pressure transducers necessary to operate them, were represented by a simple gain K_V which had the units of $\Delta \text{flow rate} / \Delta \text{current}$ and $\Delta \text{steam rate} / \Delta \text{current}$ for the reflux and steam valves respectively.

Controller: Proportional and ideal proportional-integral

controllers used in the simulation were designated by $G_c = K_c$ or $K_c(1+1/T_i s)$ where K_c has the units of $\Delta\text{current}/\Delta\text{voltage}$ and T_i is the integral time constant in minutes.

COMPOSITION CONTROL SCHEMES

Howard (15) has shown that a distillation column under transient conditions has $3N+3M+C+16$ degrees of freedom where:

N is the number of plates above the feed plate

M is the number of plates below the feed plate

C is the number of components in the feed

A good control scheme removes all these degrees of freedom to prevent column composition drift, yet does not overdetermine the system. One such control scheme, discussed by Howard (15), is shown in Figure 3. This scheme and an analogous scheme using reboil vapour rate for control are considered in this study. Instantaneous feedforward control can be added directly to either of these schemes.

The composition control schemes considered in this work are described below. Figures 4 to 11 show in block diagram form some of the control schemes that were investigated. The only disturbance for all the control schemes is an abrupt 5 mole % change in the feed composition.

1. Feedback control

1-a) Objective: Top product composition control;
manipulation of reflux rate with sensor
placed in the top product stream.

See Figure 4.

1-b) Objective: Bottom product composition control;
manipulation of reflux rate with sensor

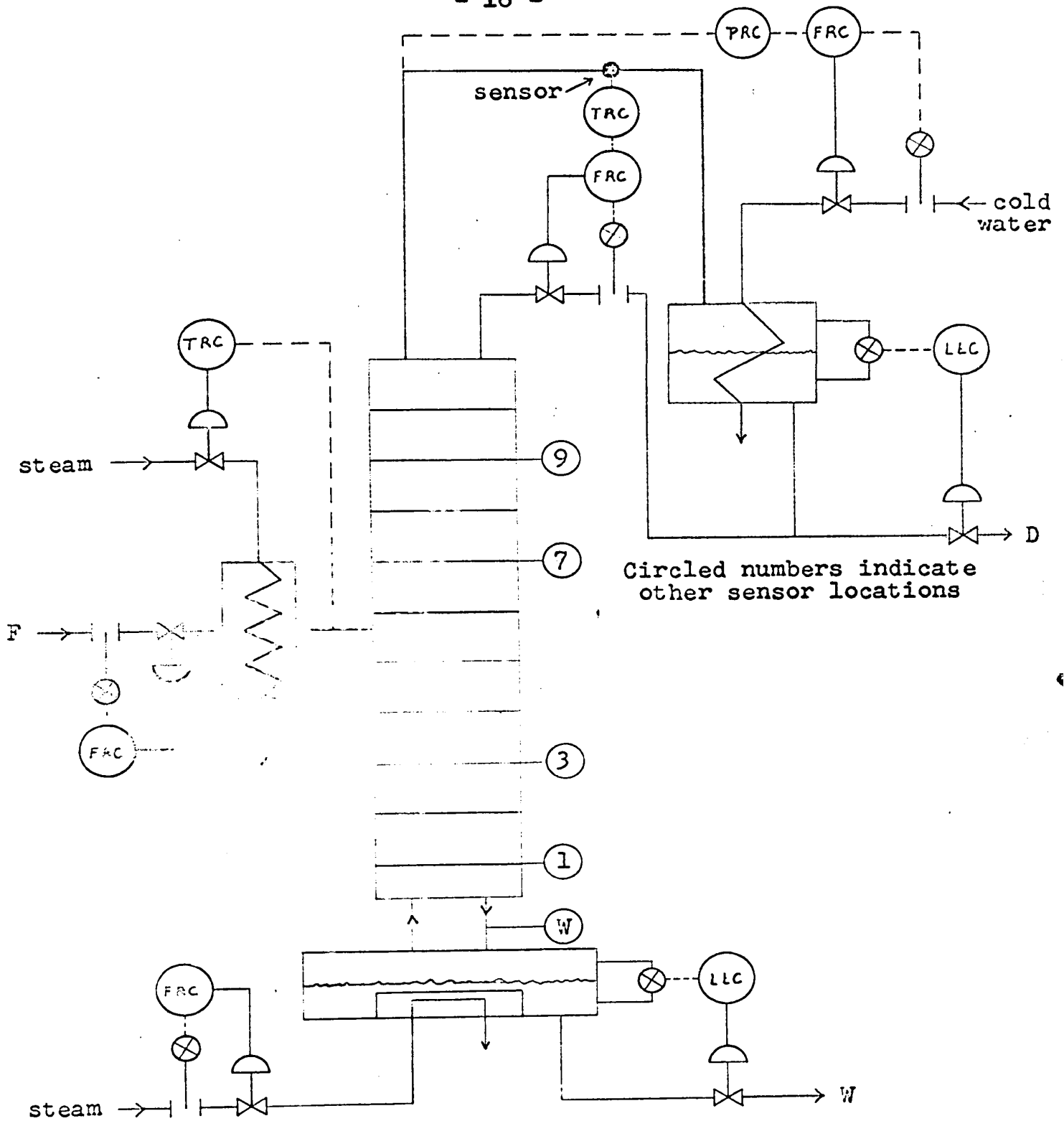

Circled numbers indicate other sensor locations

Figure 3. Control scheme using reflux rate manipulation to effect control

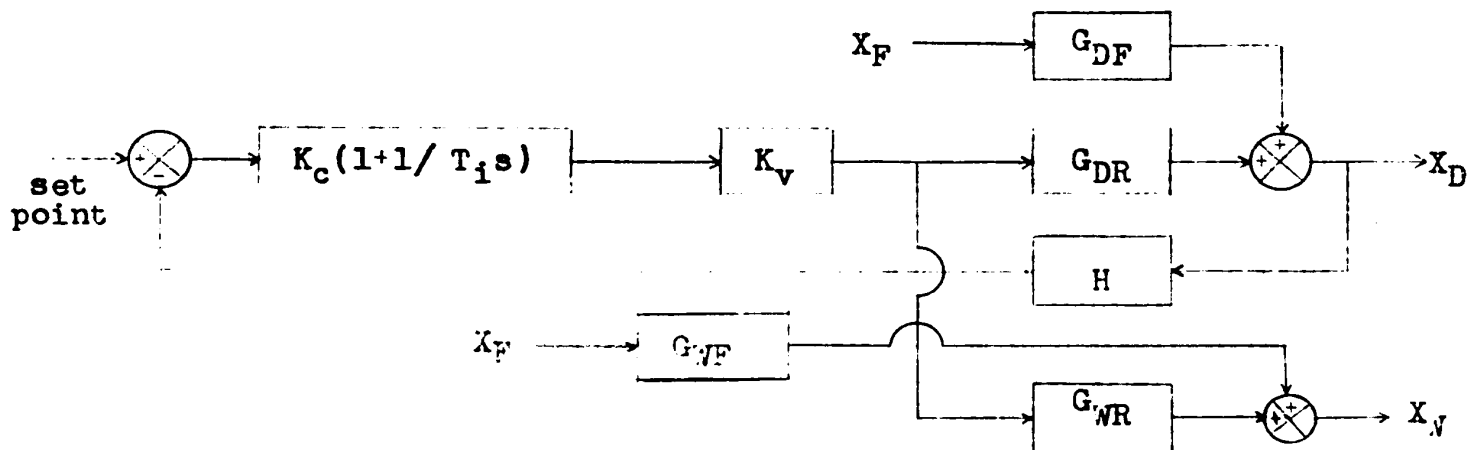

Figure 4. Feedback control of top product composition by reflux rate

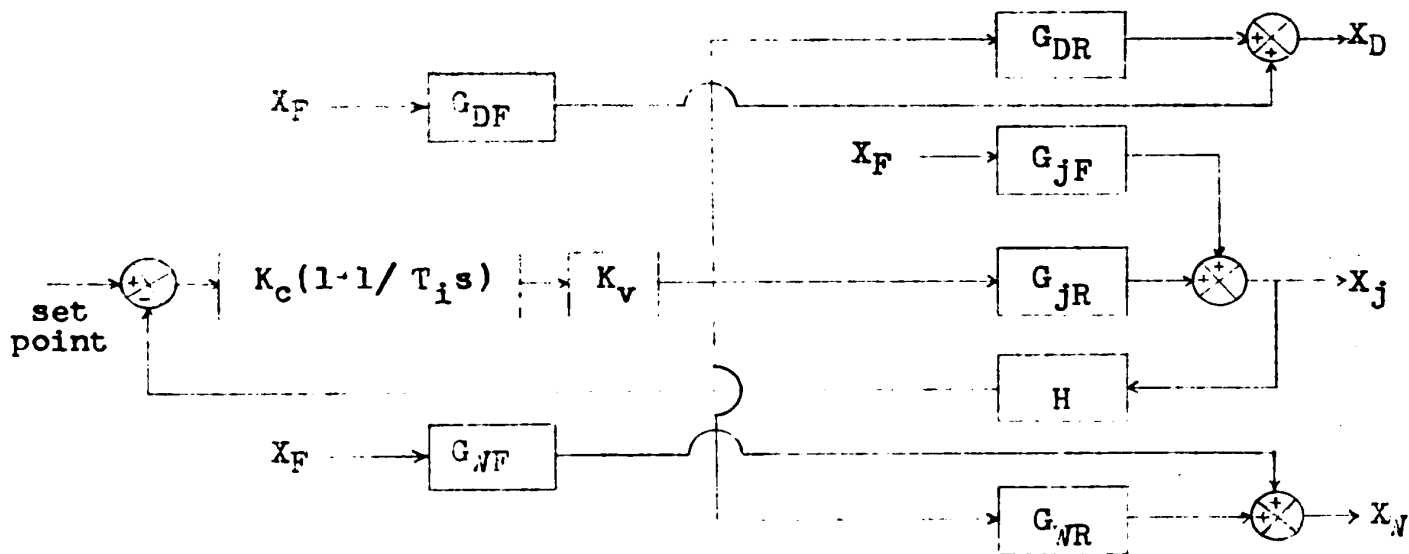

Figure 5. Feedback product composition control by reflux rate: sensor located on the j-th plate

placed in the bottom product stream.

This control scheme is analogous to that shown in Figure 4 and can be realized by replacing G_{DP} , G_{DR} , and G_{WR} by G_{WP} , G_{WR} , and G_{DR} respectively in the block diagram.

1-c) Objective: Product composition control by maintaining constant liquid composition on the j -th plate:

manipulation of the reflux rate with the sensor placed in the liquid on the j -th plate ($j = 1, 3, 7, 9$).

See Figure 5.

1-d) Objective: Top product composition control: manipulation of reboil vapour rate with the sensor placed in the top product stream.

See Figure 6.

1-e) Objective: Bottom product composition control: manipulation of reboil vapour rate with the sensor in the bottom product stream.

This control scheme is analogous to that shown in Figure 6 and can be realized by replacing G_{DP} , G_{DV} , and G_{WP} by G_{WR} , G_{WV} , and G_{DV} respectively in the block diagram.

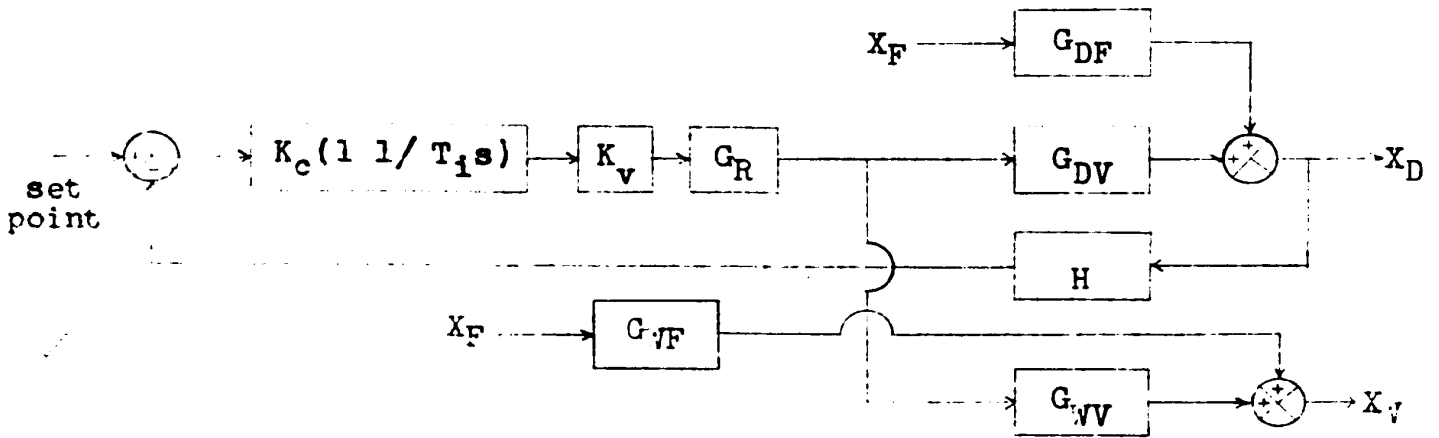

Figure 6. Feedback product composition control by reboil vapour rate

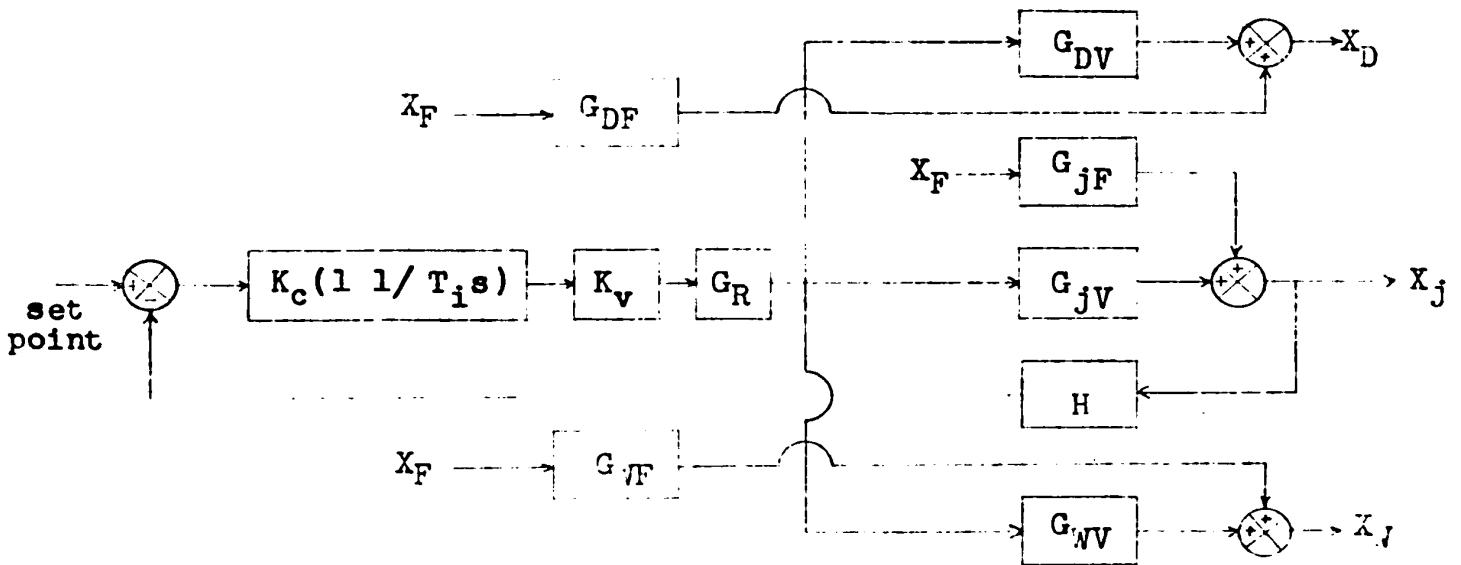

Figure 7. Feedback product composition control by reboil vapour rate: sensor located on the j-th plate

1-f) Objective: Product composition control by maintaining constant liquid composition on the j -th plate:

manipulation of the reboil vapour rate with the sensor placed in the liquid on the j -th plate ($j=1, 3, 7, 9$).

See Figure 7.

2. Instantaneous feedforward plus feedback control

2-a) Objective: Top product composition control:

manipulation of reflux rate with the sensor placed in the top product stream.

See Figure 8.

2-b) Objective: Bottom product composition control:

manipulation of reflux rate with the sensor placed in the bottom product stream.

This control scheme is analogous to that shown in Figure 8 and can be realized by replacing G_{DP} , G_{DR} , and G_{WR} by G_{WP} , G_{WR} , and G_{DR} respectively in the block diagram.

2-c) Objective: Product composition control by maintaining constant liquid composition on the j -th plate:

manipulation of the reflux rate with the sensor placed in the liquid on

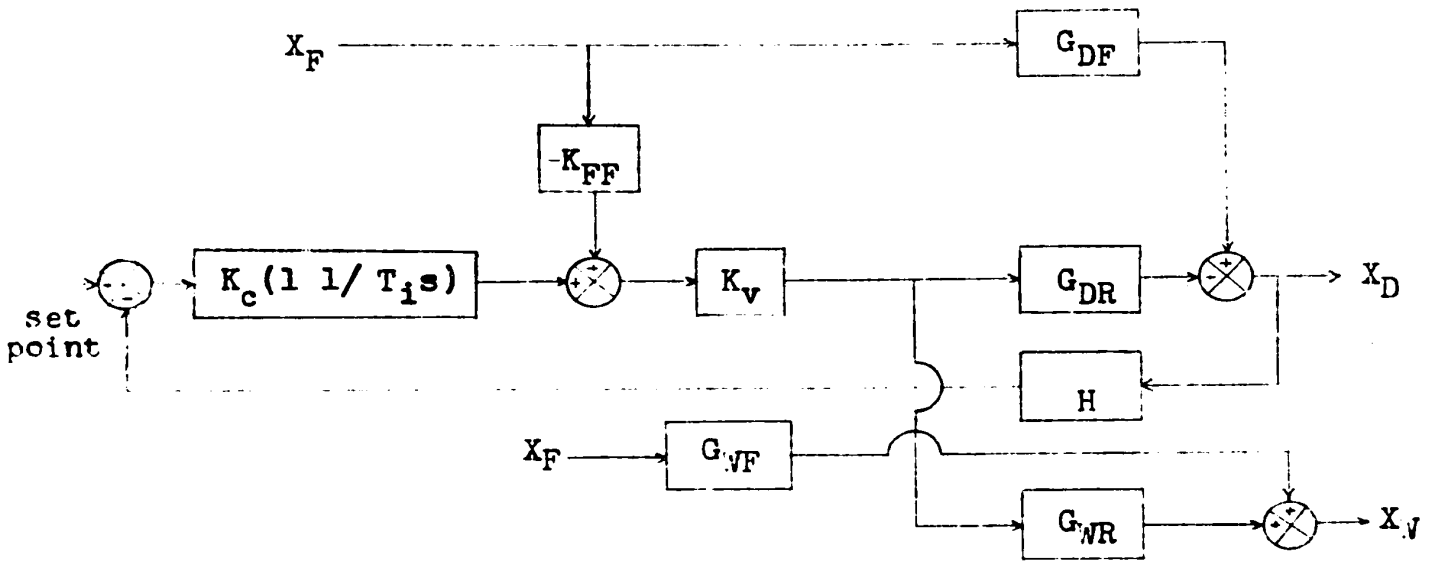

Figure 8. Feedforward plus feedback control of top product composition by reflux rate

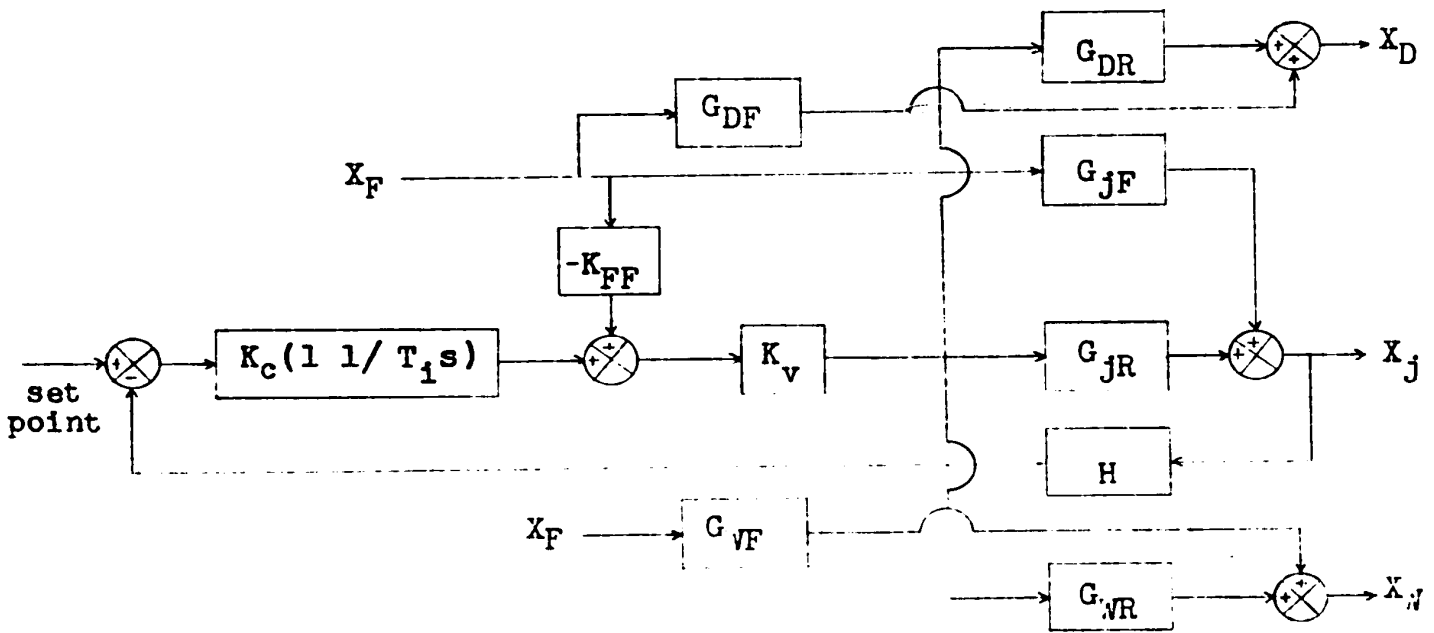

Figure 9. Feedforward plus feedback product composition control by reflux rate: sensor located on the j -th plate

the j -th plate ($j=1, 3, 7, 9$).

See Figure 9.

2-d) Objective: Top product composition control; manipulation of reboil vapour rate with the sensor placed in the top product stream.

See Figure 10.

2-e) Objective: Bottom product composition control; manipulation of reboil vapour rate with the sensor placed in the bottom product stream.

This control scheme is analogous to that shown in Figure 10 and can be realized by replacing G_{DP} , G_{DV} , and G_{WV} by G_{WP} , G_{WV} , and G_{DV} respectively in the block diagram.

2-f) Objective: Product composition control by maintaining constant liquid composition on the j -th plate;

manipulation of reboil vapour rate with the sensor placed in the liquid on the j -th plate ($j=1, 3, 7, 9$).

See Figure 11.

2-g) Objective: Top product composition control, with no offset;

manipulation of reflux rate with the

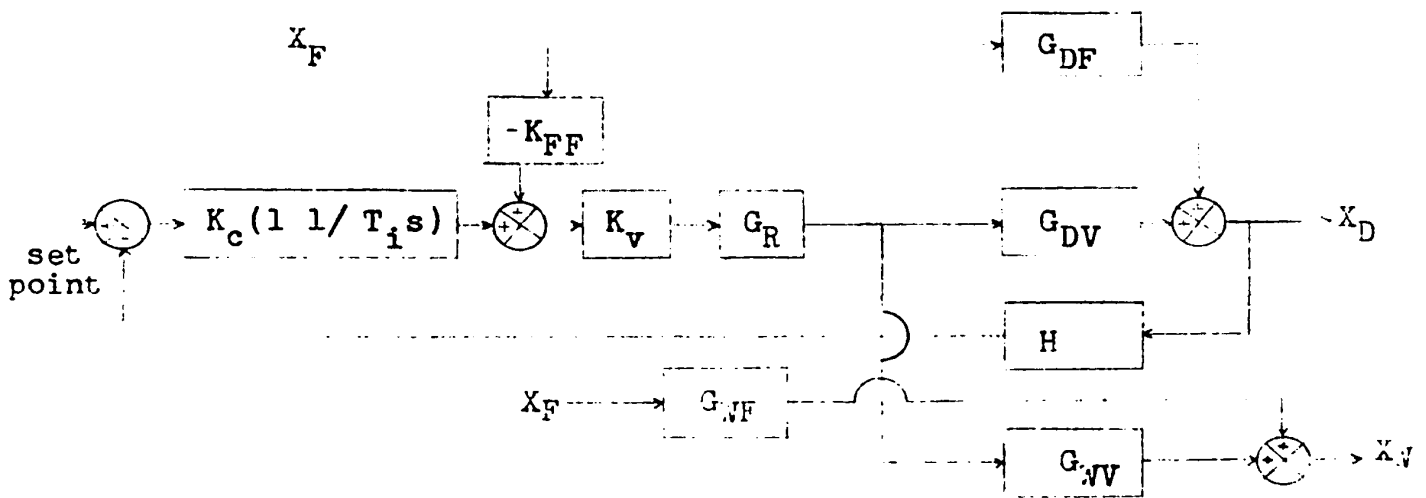

Figure 10. Feedforward plus feedback control of top product composition by reboil vapour rate

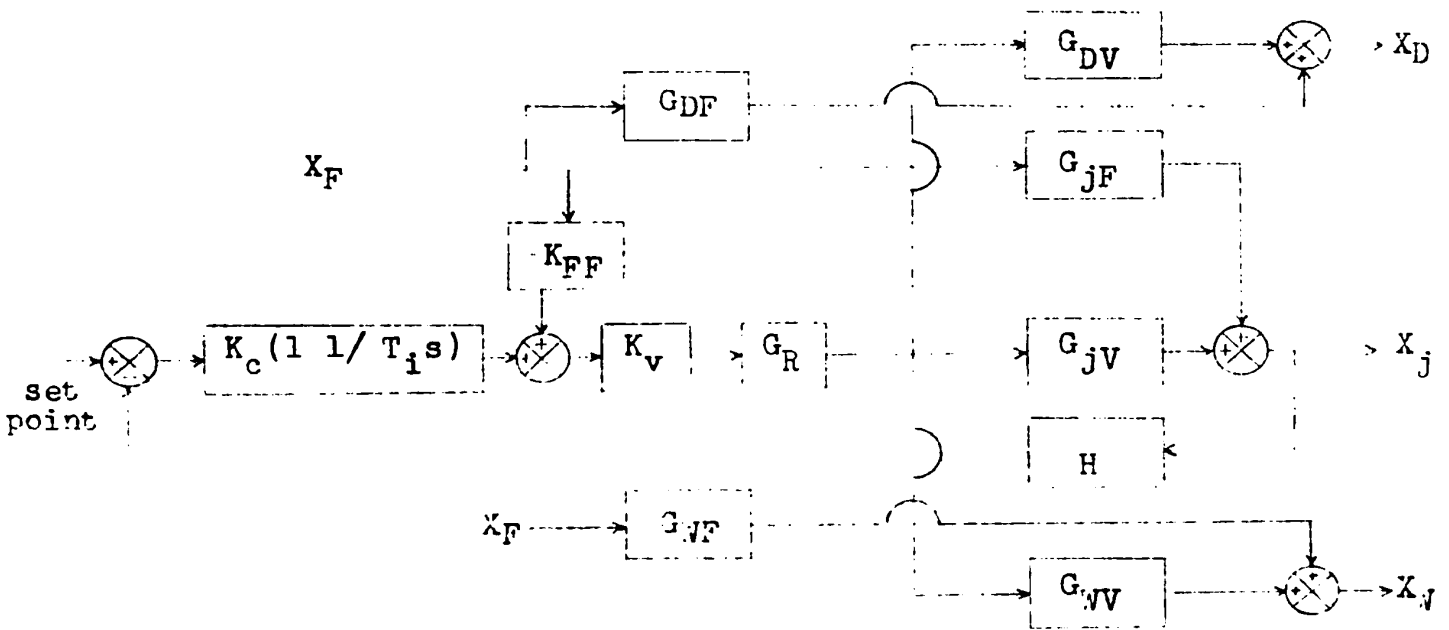

Figure 11. Feedforward plus feedback product composition control by reboil vapour rate: sensor located on the j -th plate

senser placed on the j -th plate ($j=1, 3, 7, 9$).

The block diagram is the same as shown in Figure 9, except that $1/T_1=0$.

2-h) Objective: Top product composition control, with no effect:
manipulation of reboil vapour rate with the senser placed on the j -th plate ($j=1, 3, 7, 9$).

The block diagram is the same as shown in Figure 11, except that $1/T_1=0$.

2-i) Objective: Bottom product composition control, with no effect:
manipulation of reflux rate with the senser placed on the j -th plate ($j=1, 3, 7, 9$).

The block diagram is the same as shown in Figure 9, except that $1/T_1=0$.

2-j) Objective: Bottom product composition control, with no effect:
manipulation of reboil vapour rate with the senser placed on the j -th plate ($j=1, 3, 7, 9$).

The block diagram is the same as shown in Figure 11, except that $1/T_1=0$.

SIMULATION PROCEDURE

In order to determine the optimum control parameters, K and T_1 , some performance criterion is necessary. For this work, control parameters were adjusted so that the integral $E = \int_0^{\infty} e^2 dt$ was a minimum, where e is the instantaneous deviation of the controlled variable from the desired value at all time t . This criterion was selected because it was desired to penalize large errors much more heavily than small errors so that when E is a minimum, the controlled variable should not be far from its desired value at any time. Such a response is acceptable in most regulatory control problems and is particularly suitable for distillation column control. All the control schemes were simulated on an E.A.I. TR-48 analog computer.

For control schemes 1-a to 1-f inclusive, the following search technique was employed to find the optimum control parameters:

- 1) Choose any K .
- 2) Choose any $1/T_1$ and observe the value of E for the controlled variable.
- 3) Change $1/T_1$ stepwise in such a direction as to make E smaller until the value of E goes through a minimum.
- 4) Record the values of K , $1/T_1$, and E .
- 5) Select a new value of K and repeat steps 2, 3,

and k until an absolute minimum is observed. The values of K and $1/T_1$ that yield the absolute minimum of E are the optimum control parameters.

For control schemes 2-a to 2-f inclusive, the following search technique was employed to find the optimum control parameters:

- 1) Choose any K .
- 2) Set $1/T_1 = 0$ and by trial and error find K_{pp} so that the effect in the controlled variable is zero.
- 3) Choose any $1/T_1$ and observe the value of E for the controlled variable.
- 4) Change $1/T_1$ stepwise in such a direction as to make E smaller until the value of E goes through a minimum.
- 5) Record the values of K , K_{pp} , $1/T_1$, and E .
- 6) Select a new value of K and repeat steps 3, 4, and 5 until an absolute minimum of E is observed. The values of K , K_{pp} , and $1/T_1$ that yield the absolute minimum of E are the optimum control parameters.

It was found that for the above control schemes $1/T_1$ was always zero for minimum error, and therefore the above procedure can be simplified to:

- 1) Choose any K .
- 2) Set $1/T_1 = 0$ and by trial and error find K_{PP} so that the effect in the controlled variable is zero.
- 3) Observe the value of E for the controlled variable and change K stepwise in such a direction as to make E smaller. When E reaches a minimum, the corresponding K along with K_{PP} are the optimum control parameters.

Integral control ensures that the controlled variable has zero effect at the cost of decreased stability. Since in the present case zero effect is already assured by our selection of K_{PP} , the integral control mode adds nothing but still causes a decrease in stability. Hence, our penalty function will be a minimum only when $1/T_1 = 0$. However in actual implementation a small value of $1/T_1$ should be used in order to prevent composition drift on the control plate.

For control schemes 2-g to 2-j inclusive, the following search technique was employed to find the optimum control parameters:

- 1) Set $1/T_1 = 0$.
- 2) Choose any K_{PP} .
- 3) By trial and error find a K such that offset in X_p or X_y is zero and record the value of E for the controlled variable.

4) Select a new value of K_{FF} and repeat step 3.

The combination of K and K_{FF} that makes E a minimum constitutes the optimum control parameters.

The results of the optimum control parameter search are tabulated in Appendix B in terms of K , $1/T_1$, and K_{FF} where:

$K = K_o K_v K_M$ when reflux rate is used to effect control and

$K = K_o K_v K_M K_R$ when reboil vapour rate is used to effect control.

The gain of the reboiler, K_R , was

$$K_R = 5.0 \text{ (lb.-moles/min. reboil vapour)/(lb./min. steam)}$$

It was considered that K_v and K_M could be arbitrarily chosen by the designer provided the following constraints are observed:

1) Feedback case using reflux rate for control

$$K_M K_v = K/K_o$$

2) Feedback case using reboil vapour rate for control

$$K_M K_v = K/5K_o$$

3) Instantaneous feedforward plus feedback case using reflux rate for control

$$K_v = K_L / K_{FF} K_P$$

$$K_M = K / K_o K_v$$

4) Instantaneous feedforward plus feedback case using reboil vapour rate for control

$$K_v = K_L / 5K_{FF} K_P$$

$$K_M = K / 5K_c K_v$$

RESULTS

Figures 12 to 51 inclusive show the performance of all the control schemes when they were operated at the optimum control parameter settings. In these figures, compositions have the units of mole % acetone and the time is in minutes. The range of stable operation for the feedback control schemes is shown in Figures 58 to 69 inclusive in Appendix B. The optimum control parameter values are also shown in Appendix B. Appendix C shows the analog computer circuits and potentiometer settings used to simulate the control schemes.

I FEEDBACK CONTROL

- A) Control criterion: minimize $\int e^2 dt$ for the control plate
Manipulative control: reflux rate

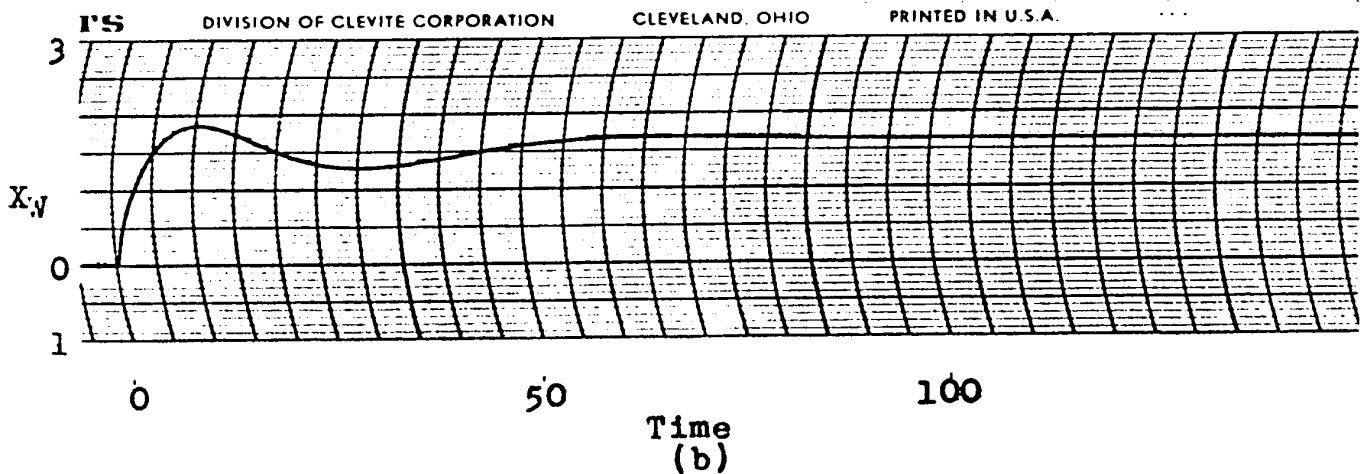
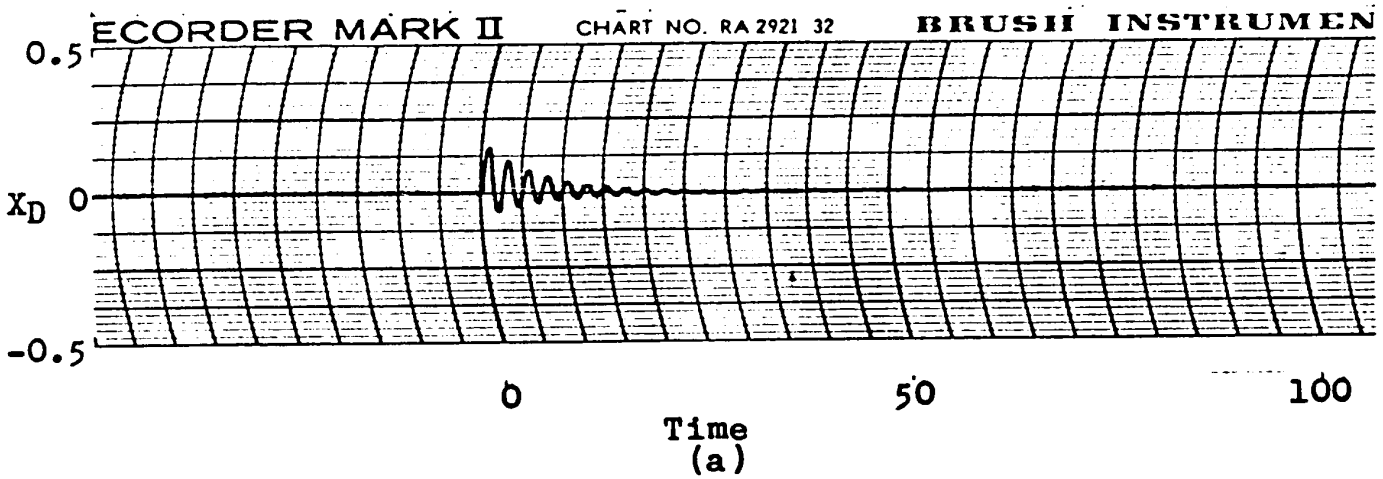

Figure 12. Response of product compositions when the sensor is in the top product

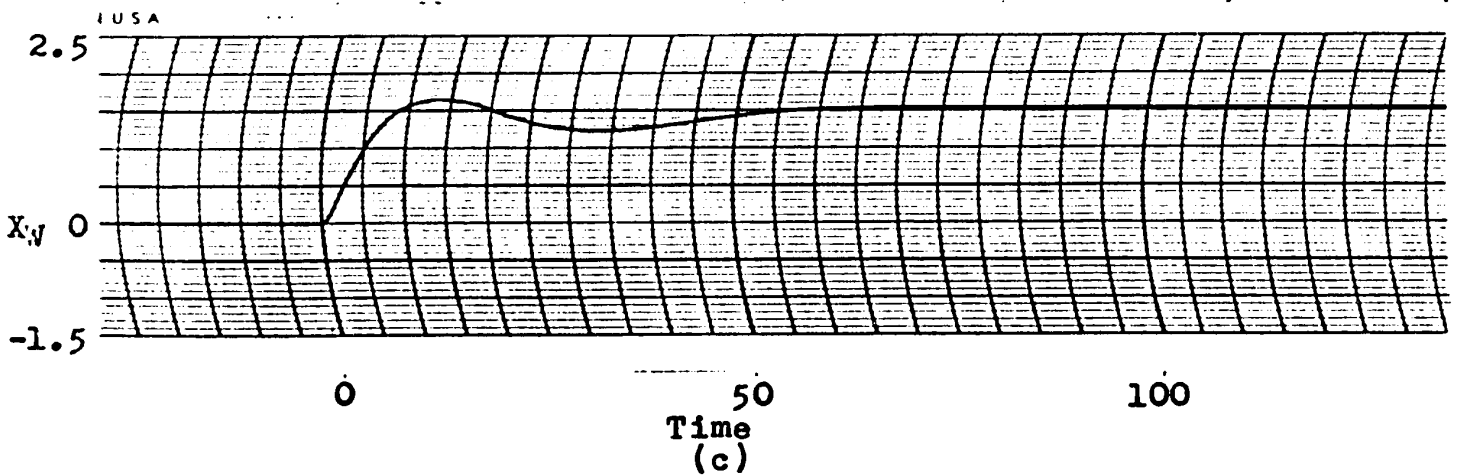
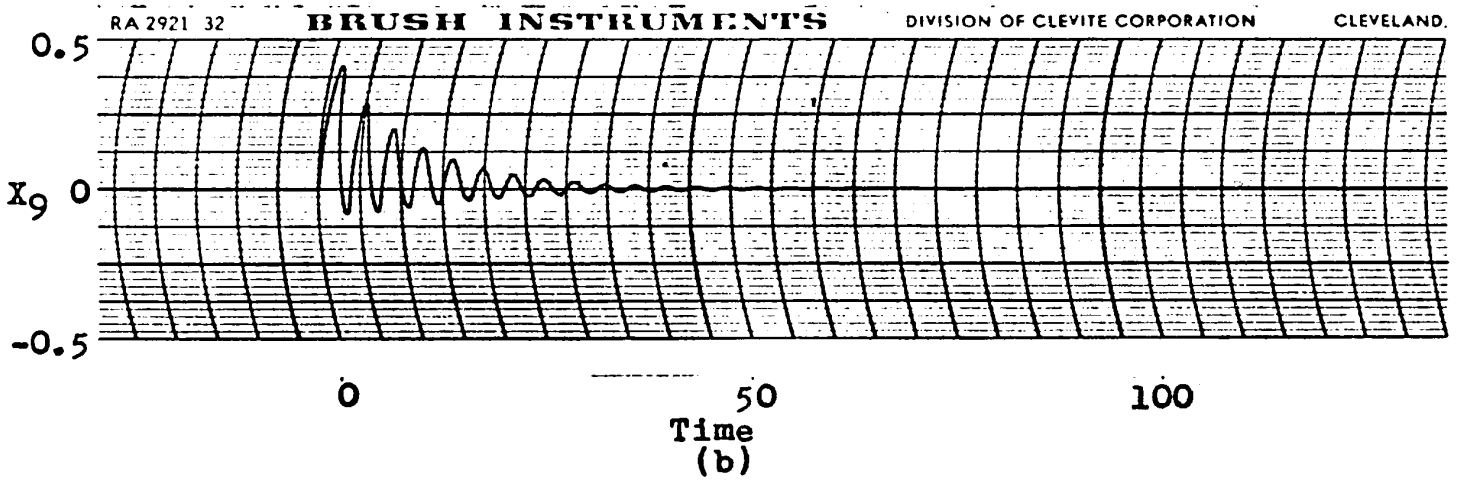
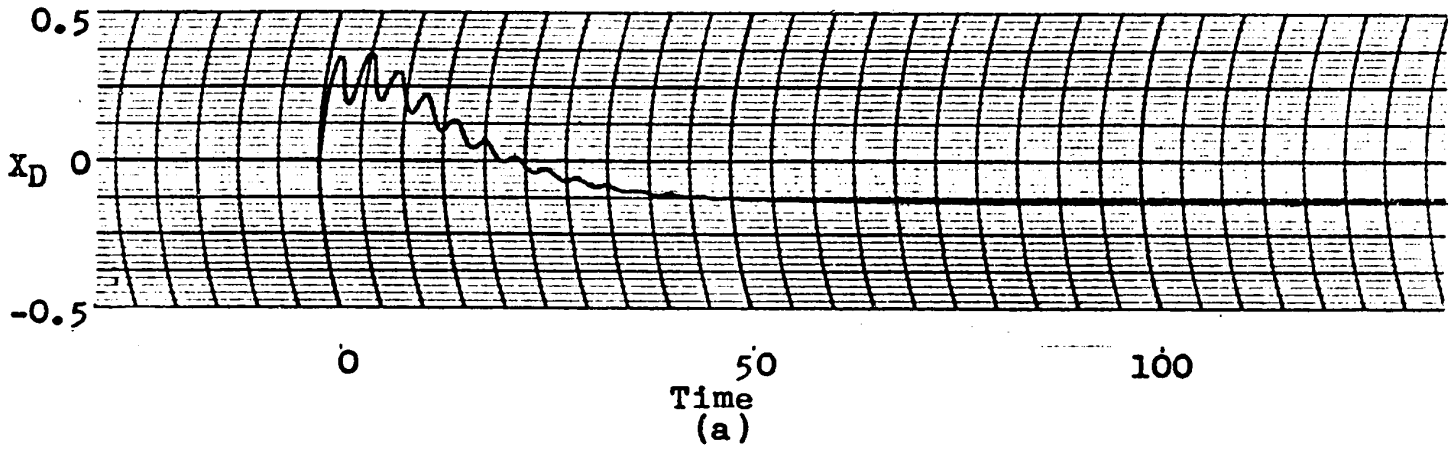

Figure 13. Response of control plate and product compositions when the sensor is on plate 9.

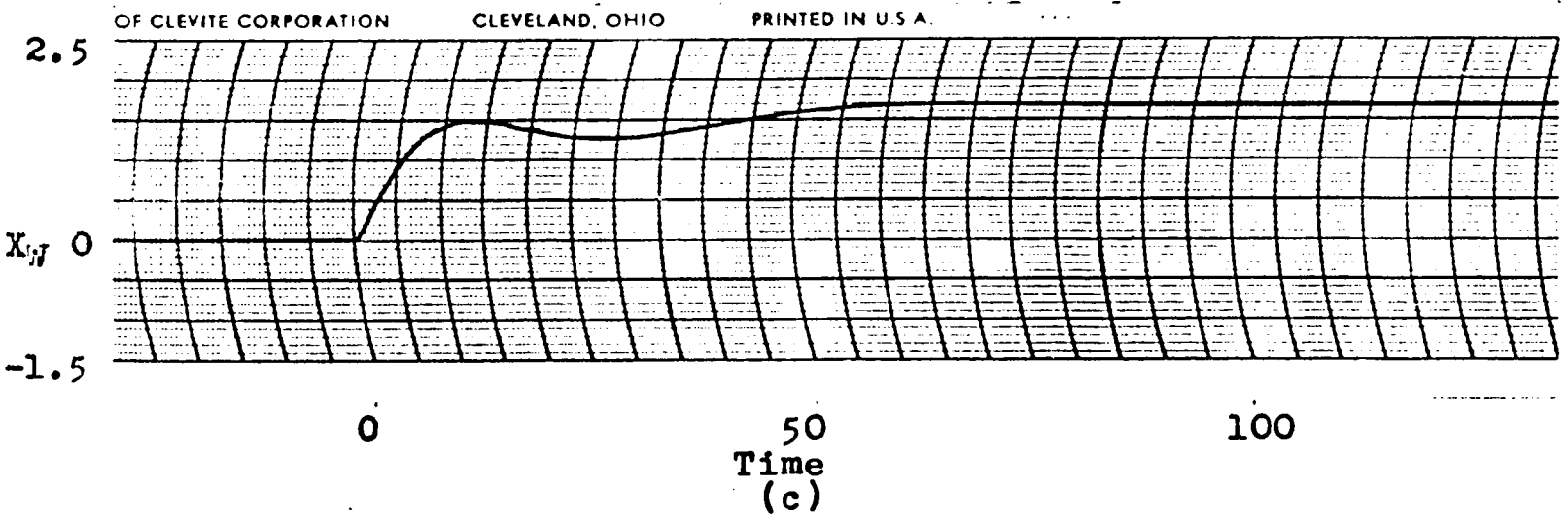
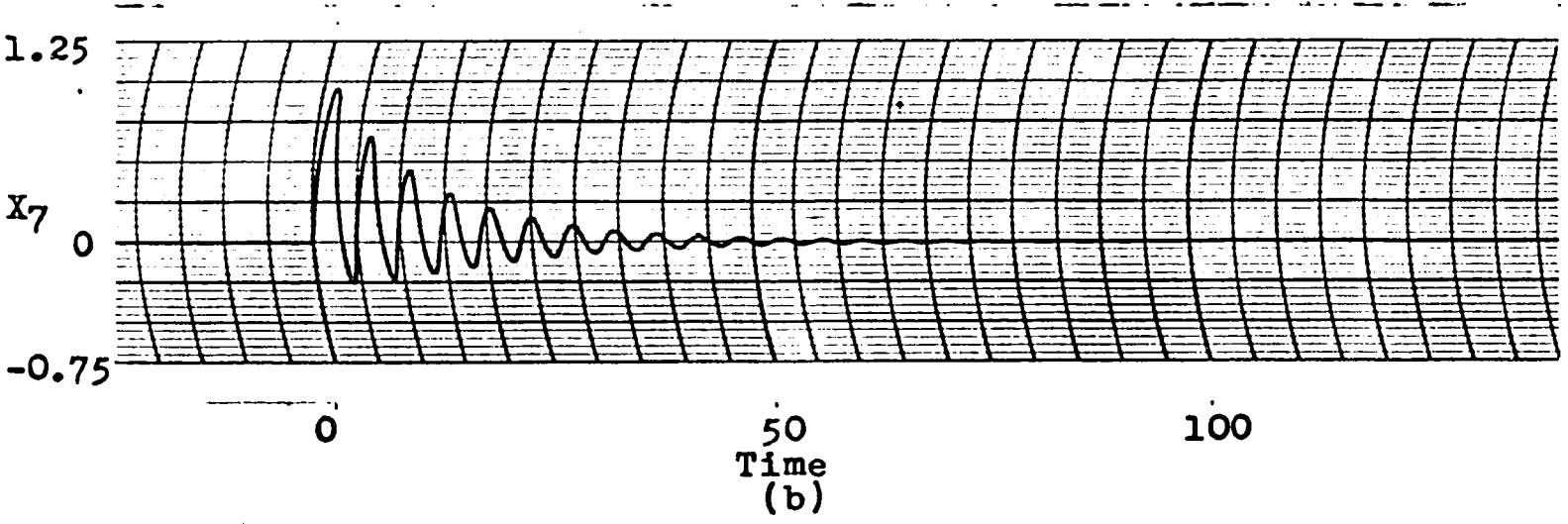
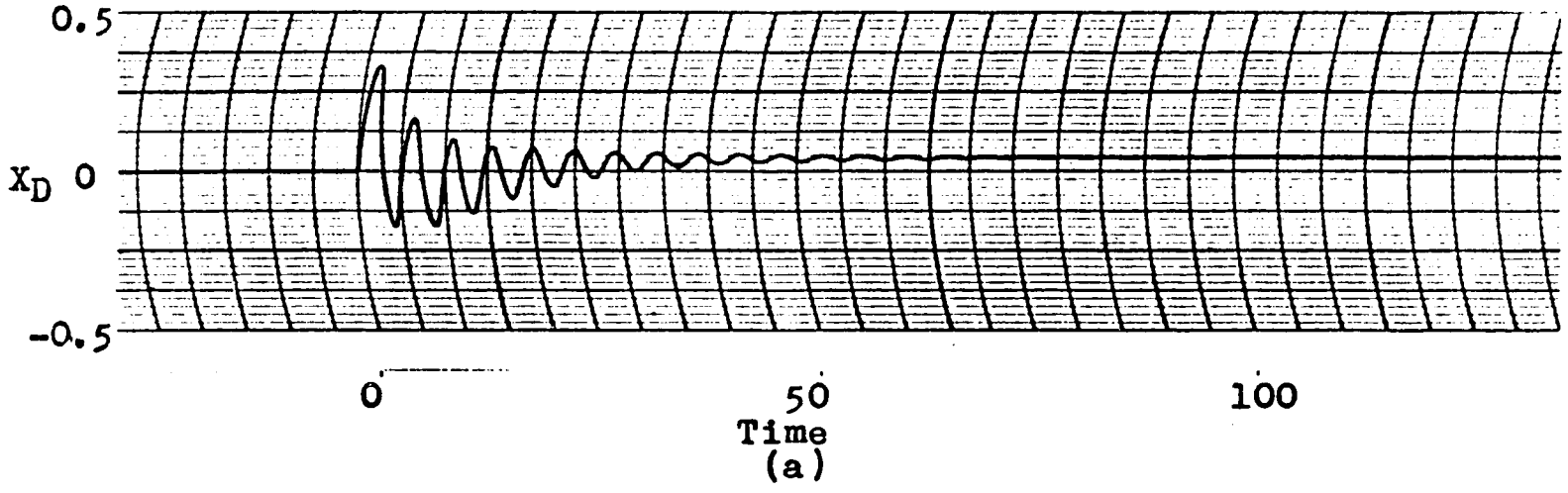

Figure 14. Response of control plate and product compositions when the sensor is on plate 7.

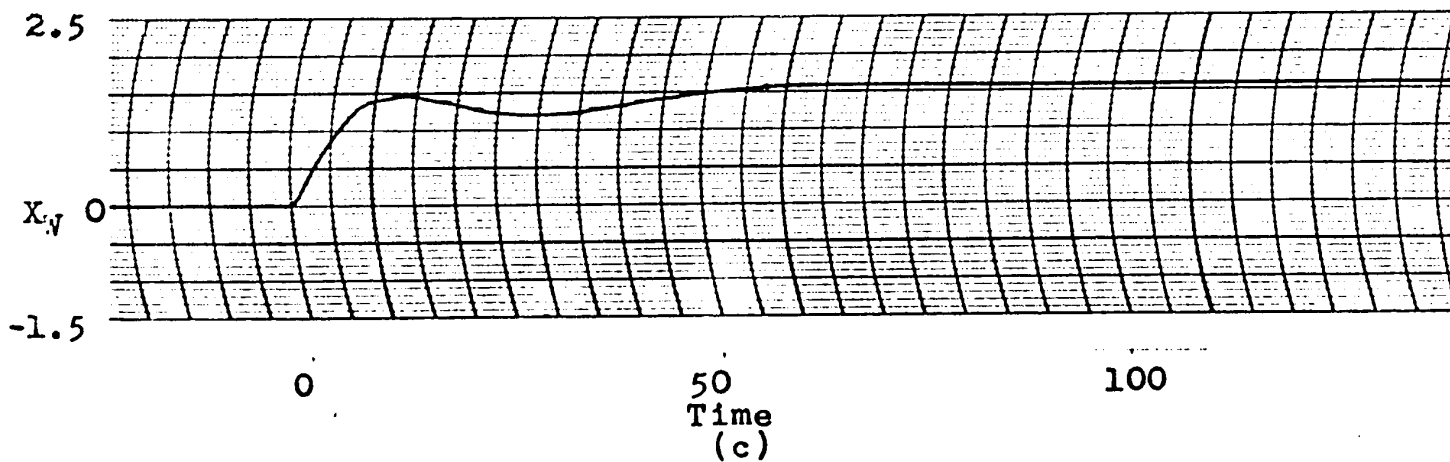
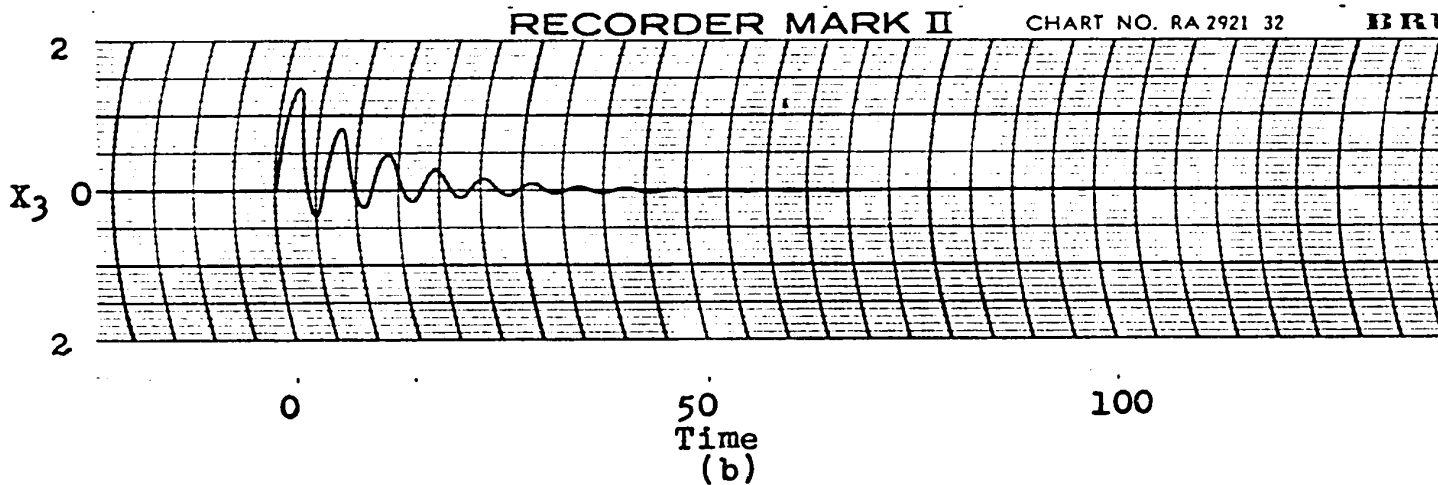
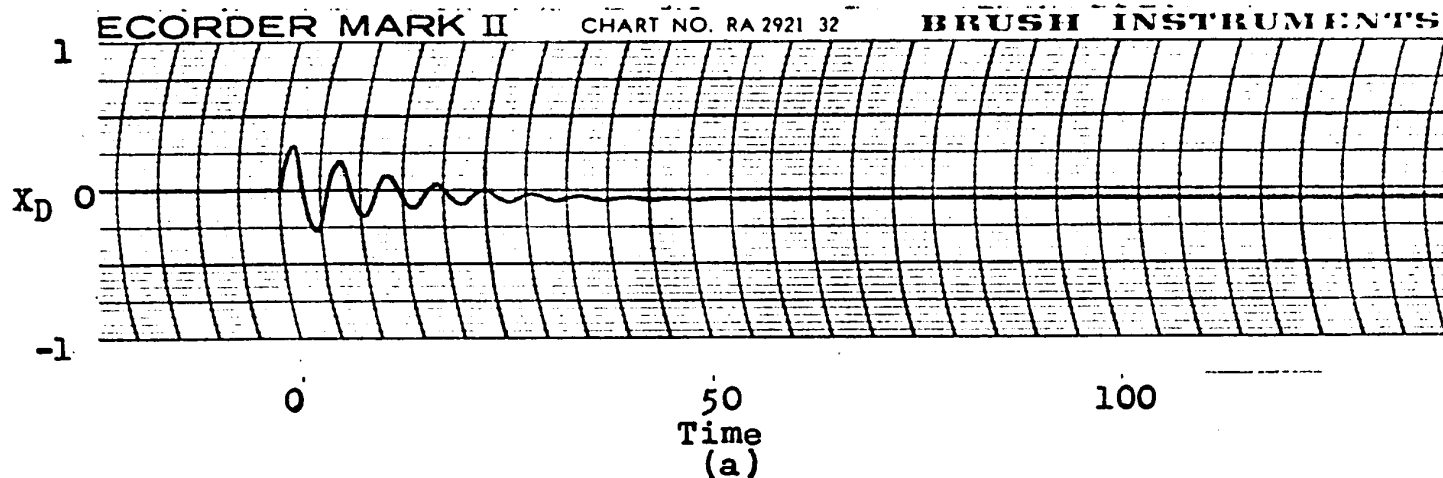

Figure 15. Response of control plate and product compositions when the sensor is on plate 3.

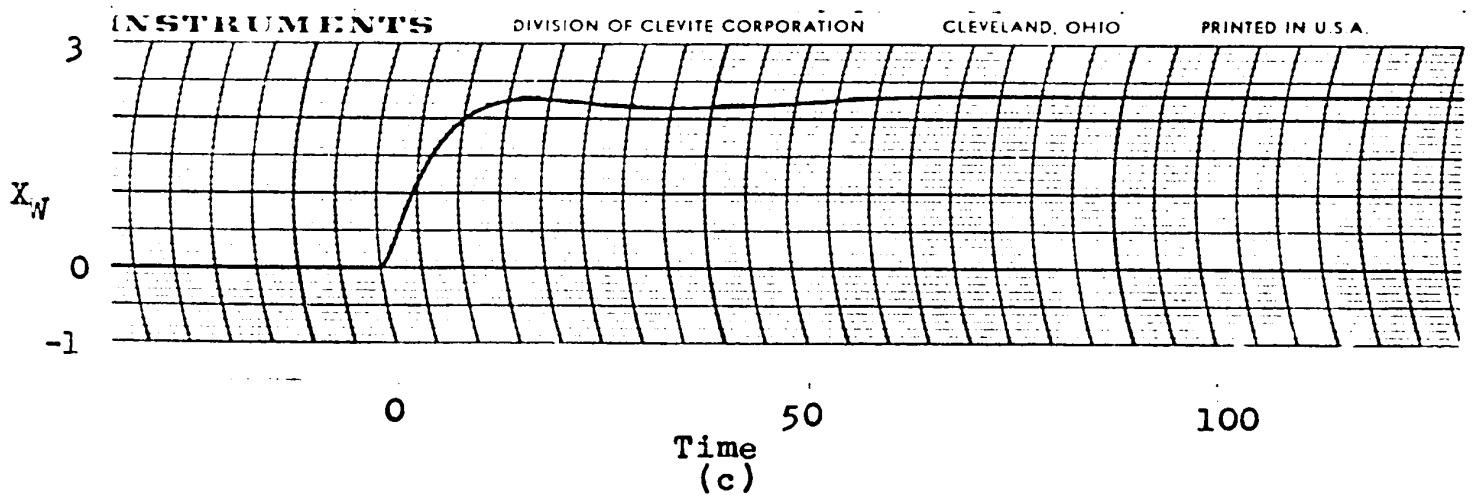
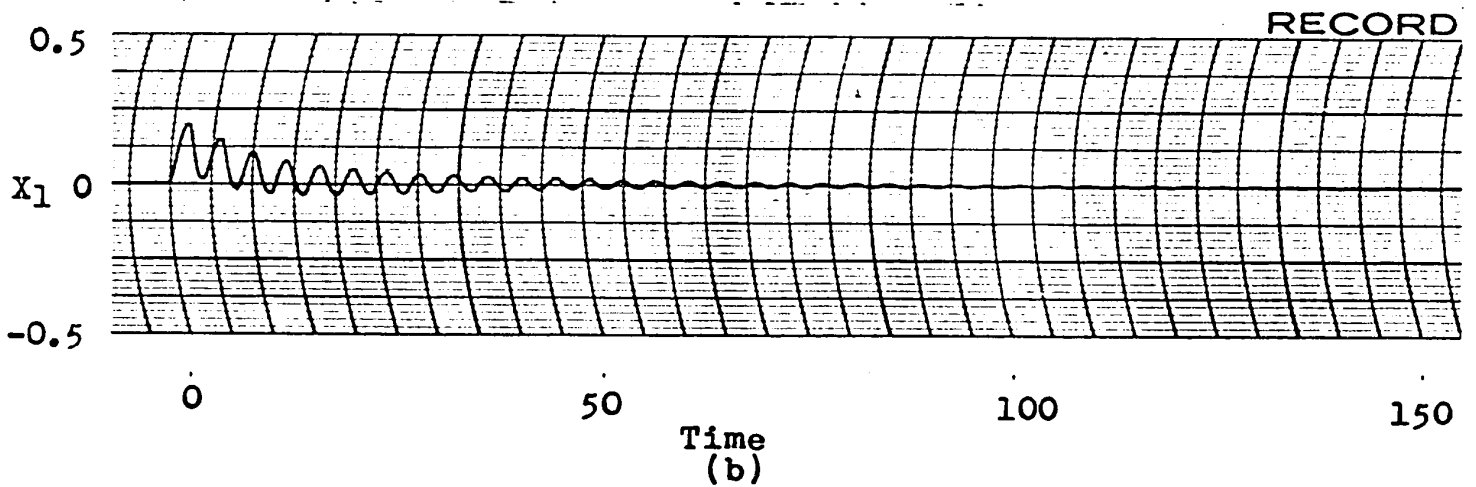
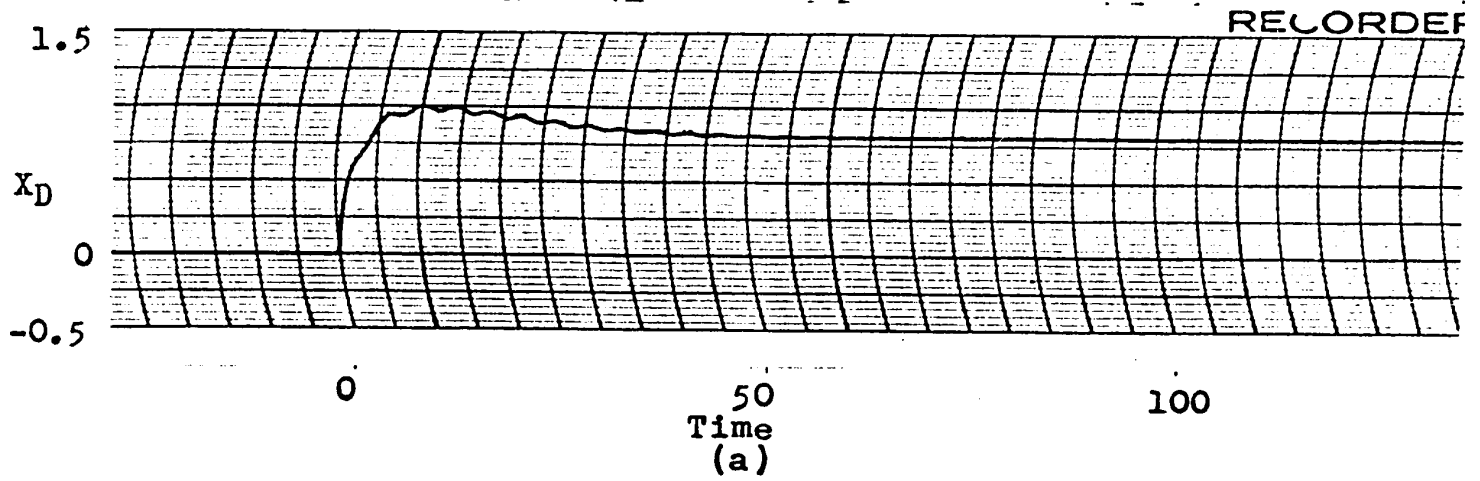
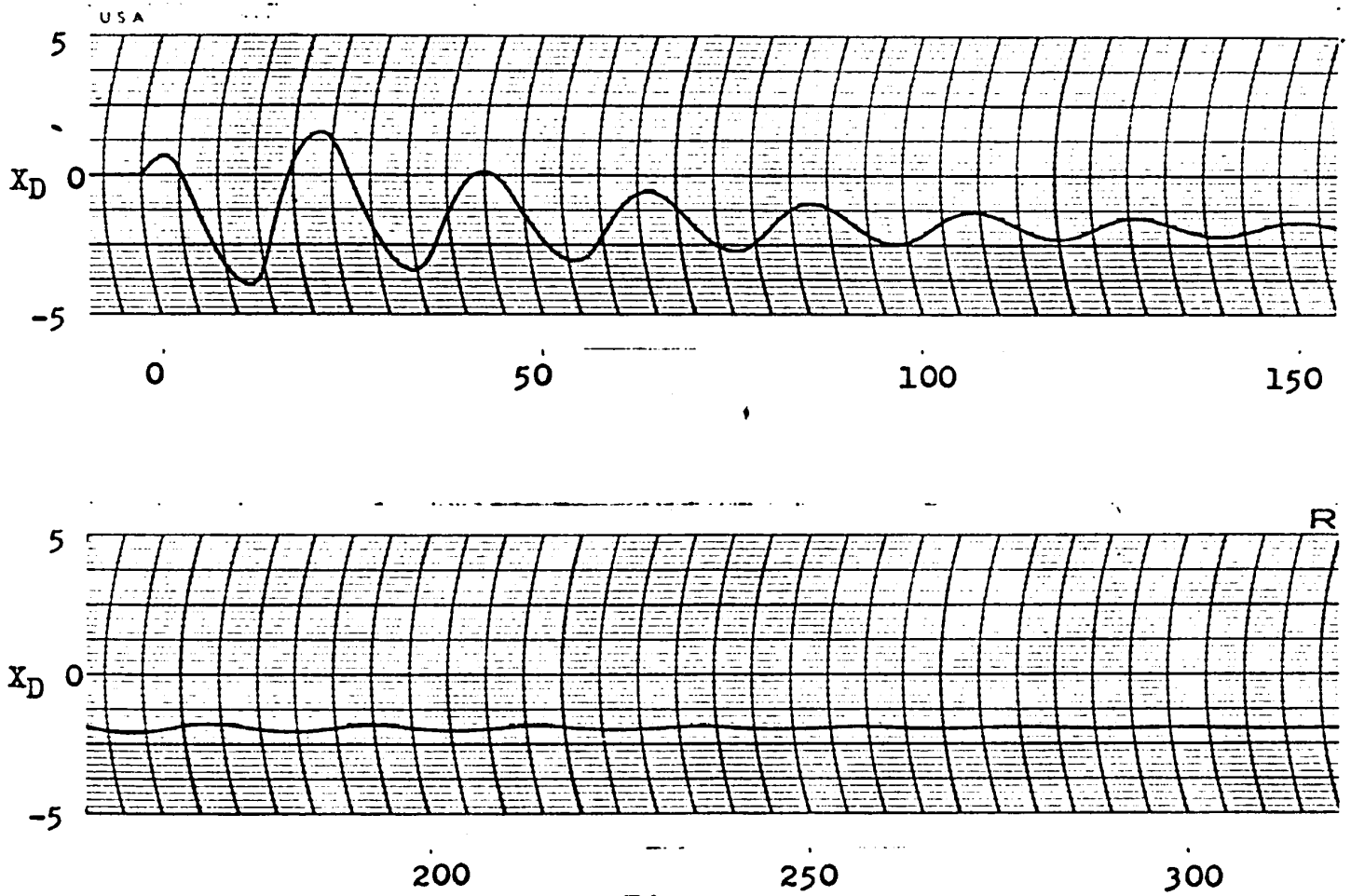

Figure 16. Response of control plate and product compositions when the sensor is on plate 1.



Time
(a)
(Figure 17)

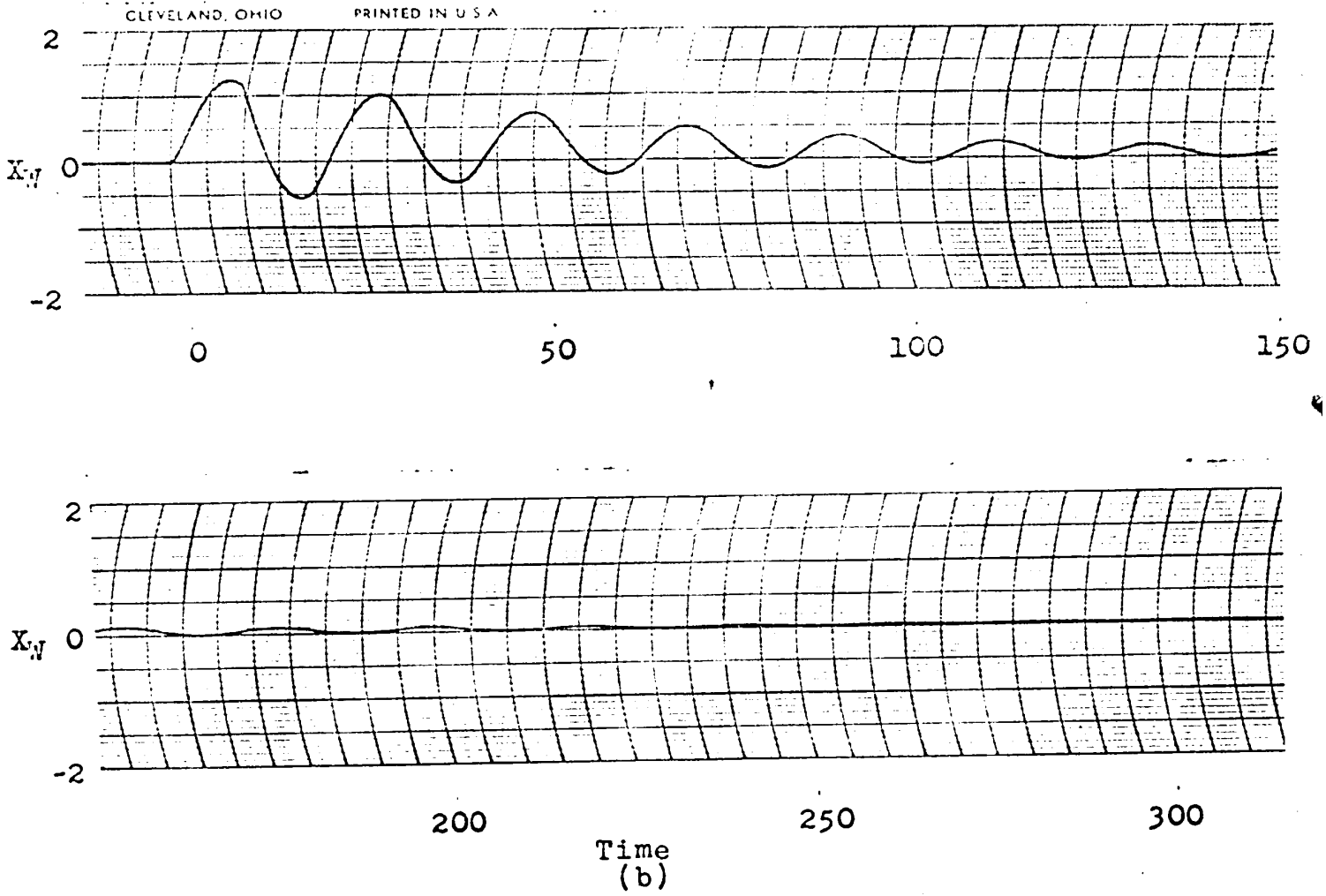

Figure 17. Response of product compositions when the sensor is in the bottom product.

B) Control criterion: minimize $\int_0^T e^2 dt$ for the control plate
Manipulative control: reboil vapour rate

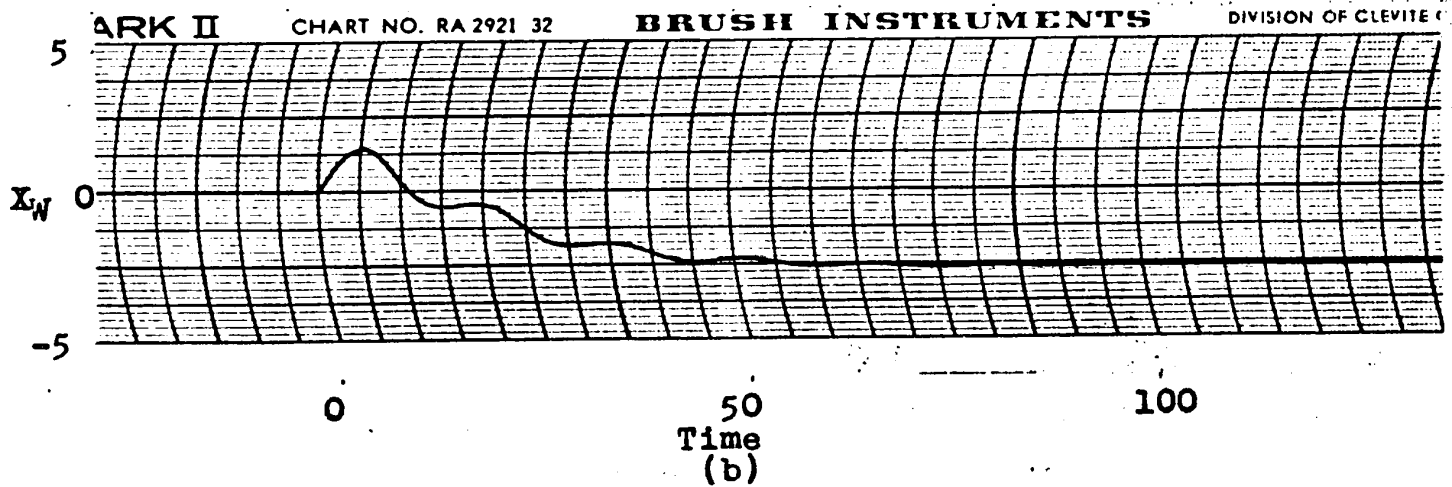
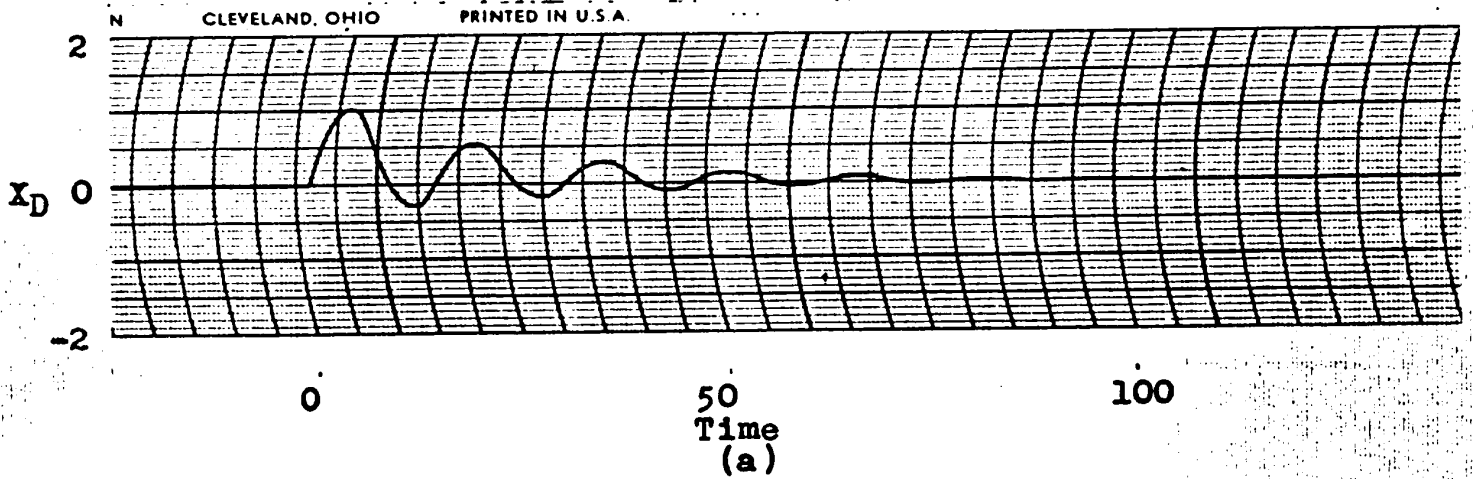

Figure 18. Response of product compositions when the sensor is in the top product.

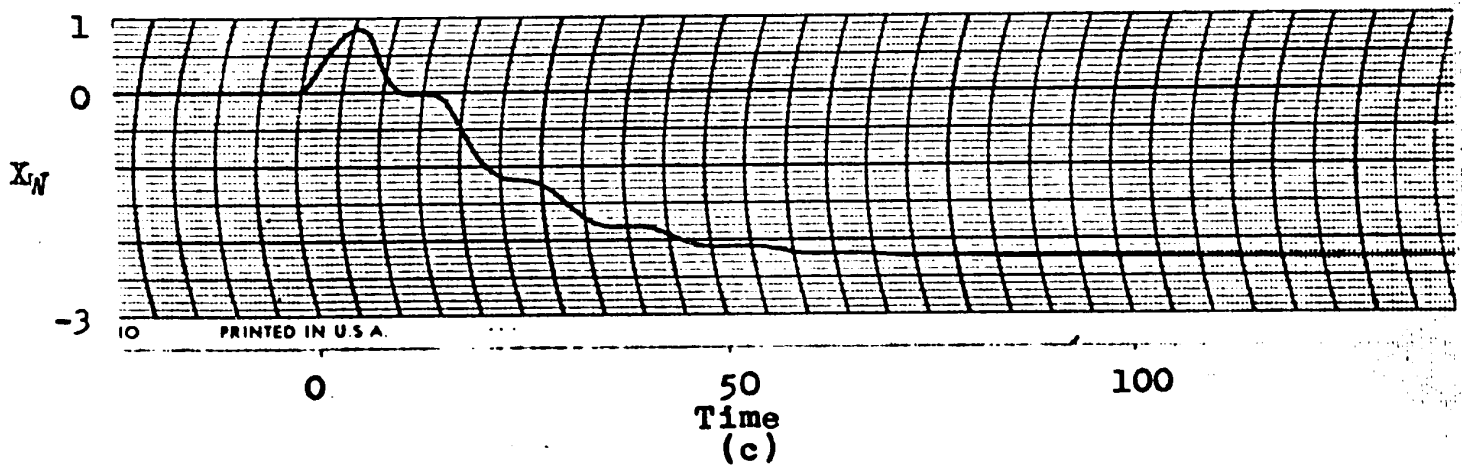
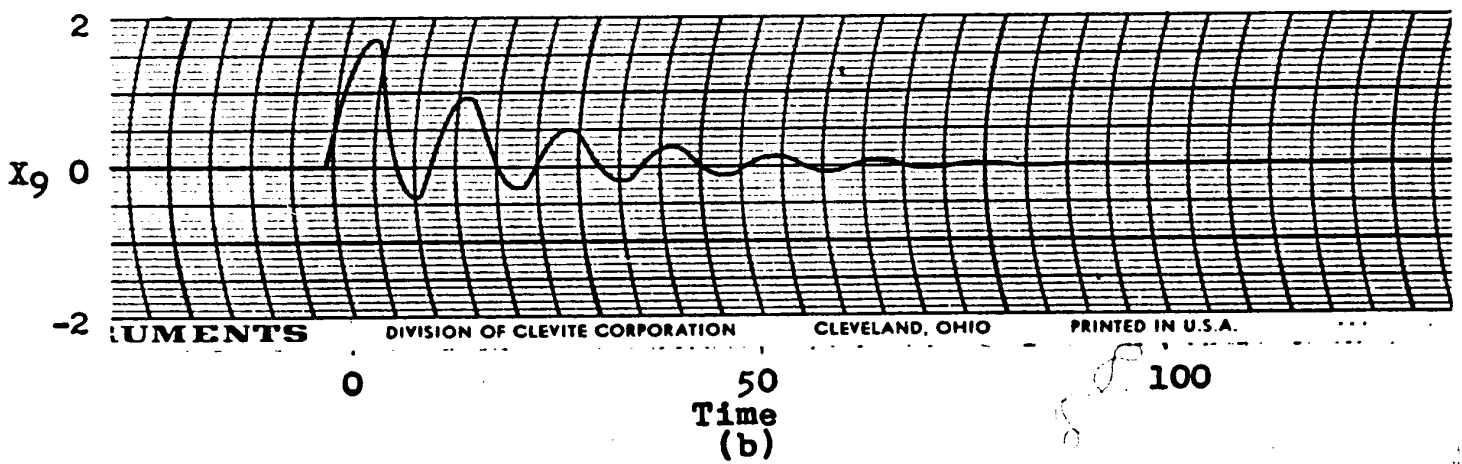
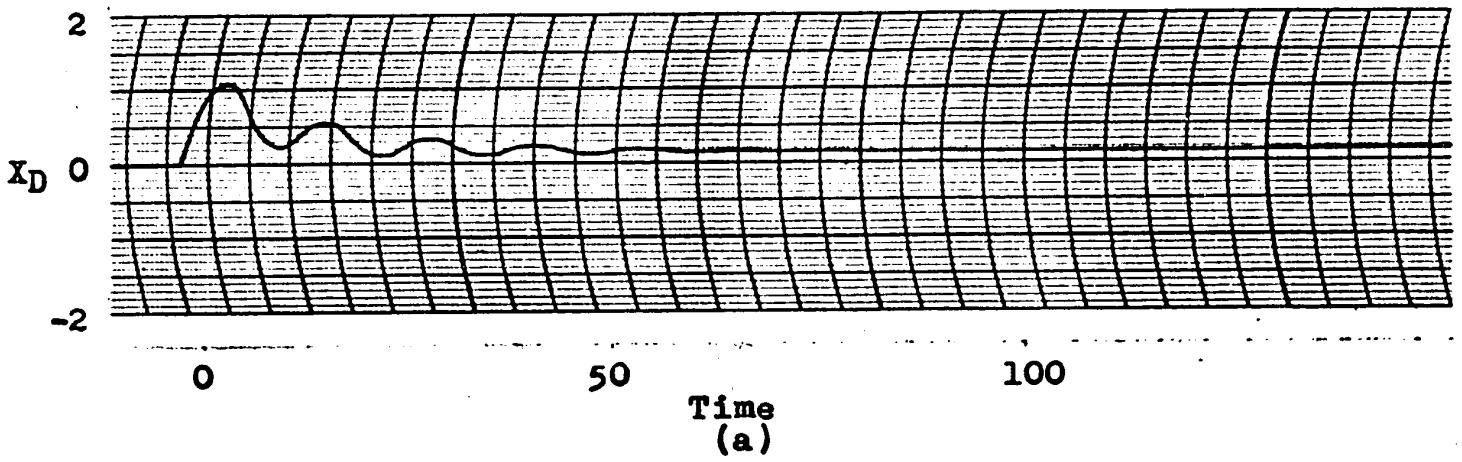

Figure 19. Response of control plate and product compositions when the sensor is on plate 9.

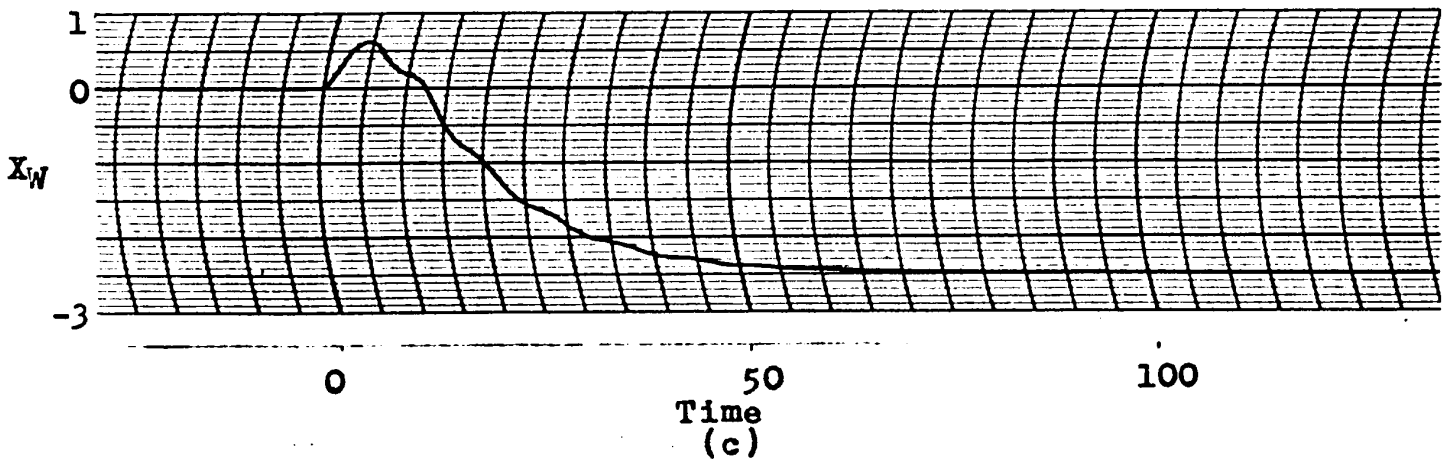
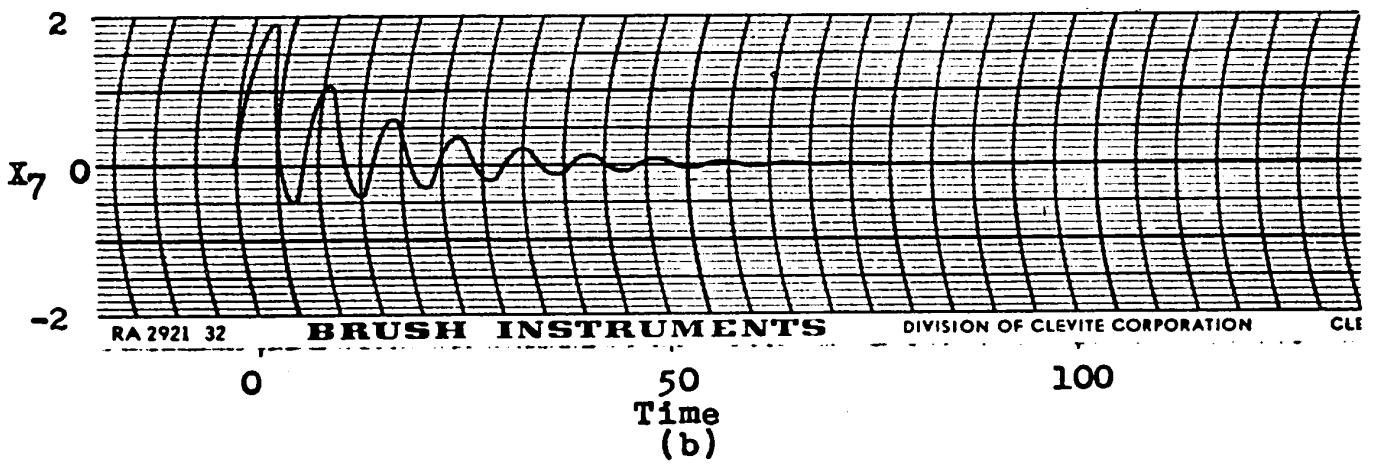
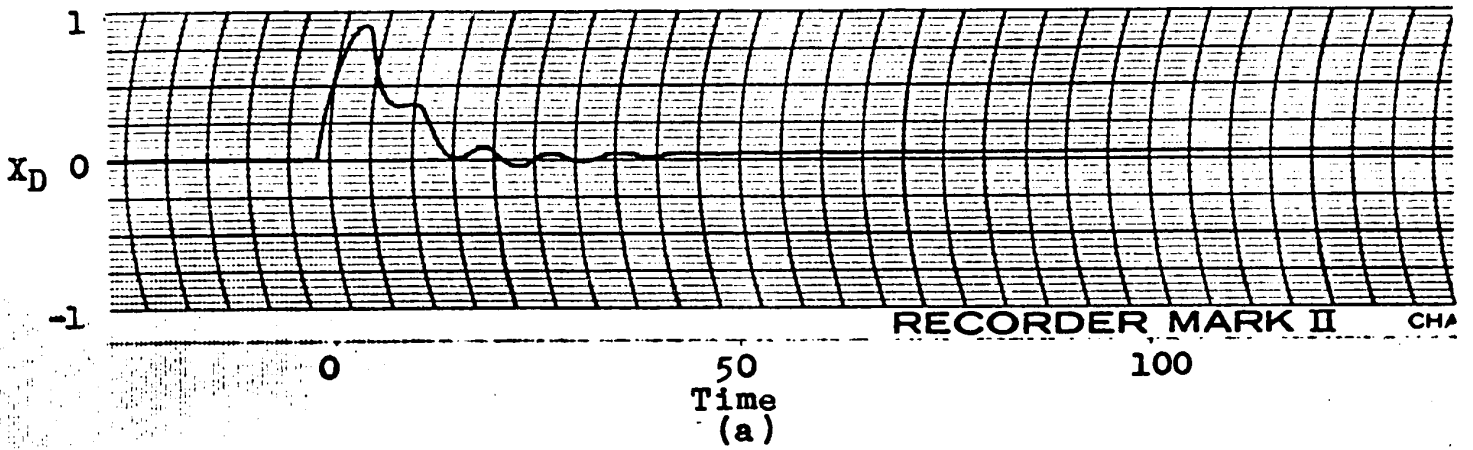

Figure 20. Response of control plate and product compositions when the sensor is on plate 7.

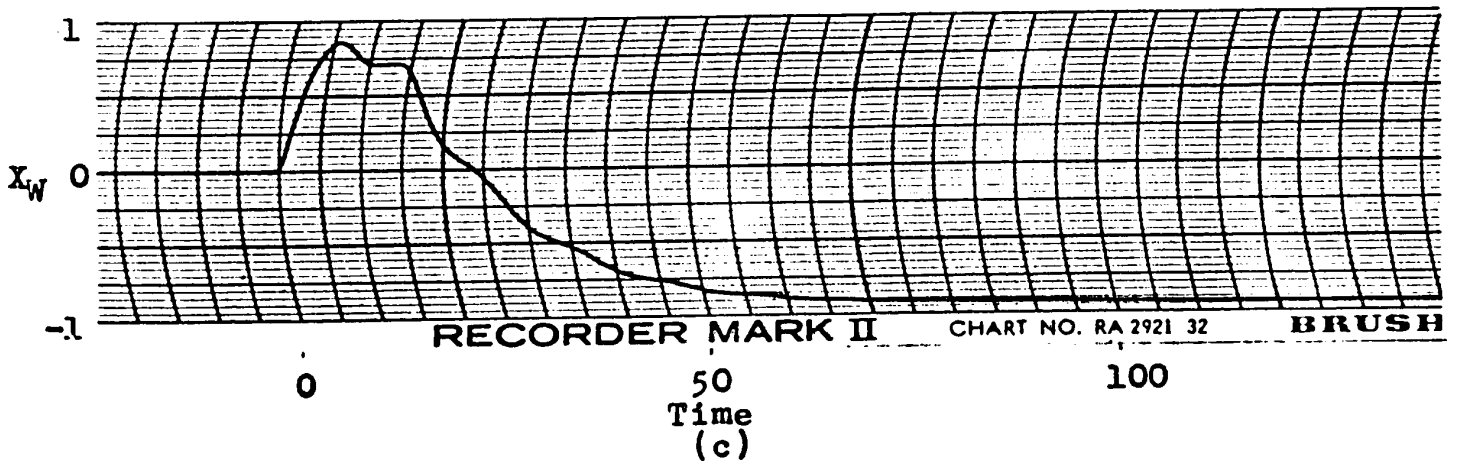
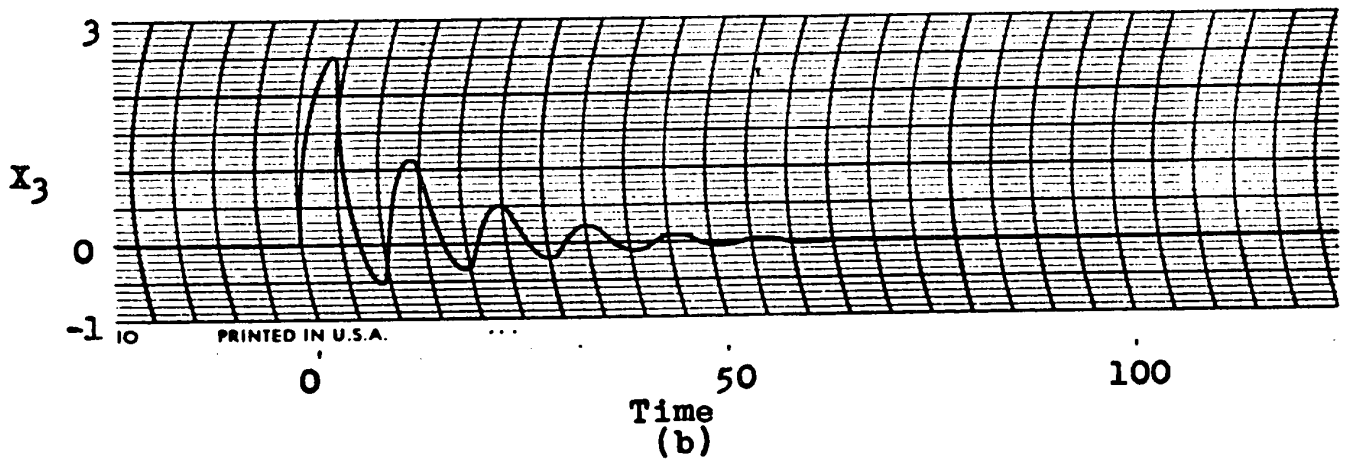
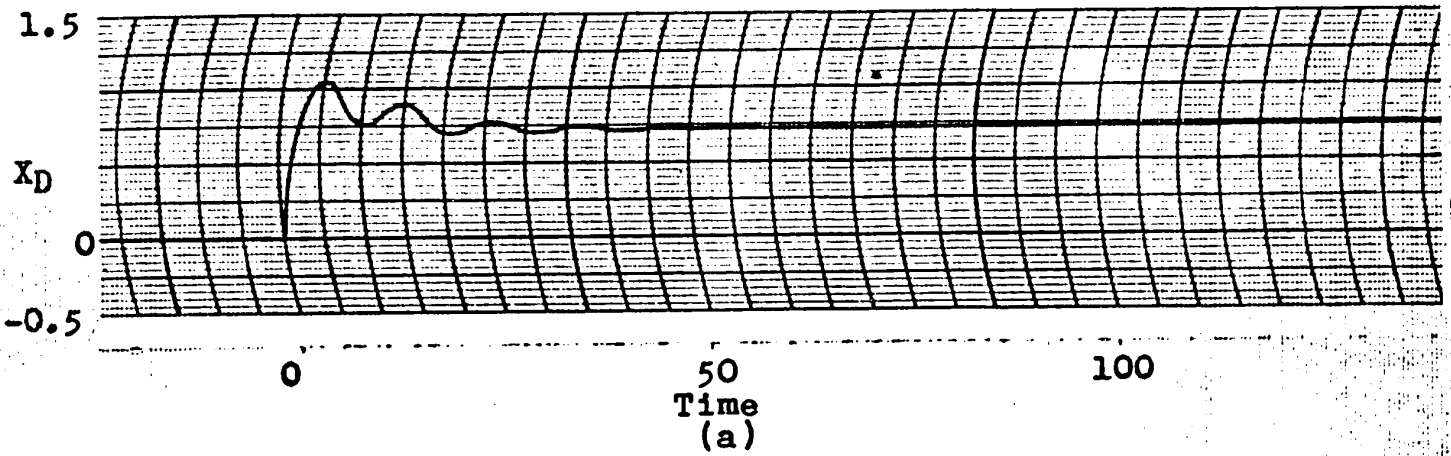

Figure 21. Response of control plate and product compositions when the sensor is on plate 3.

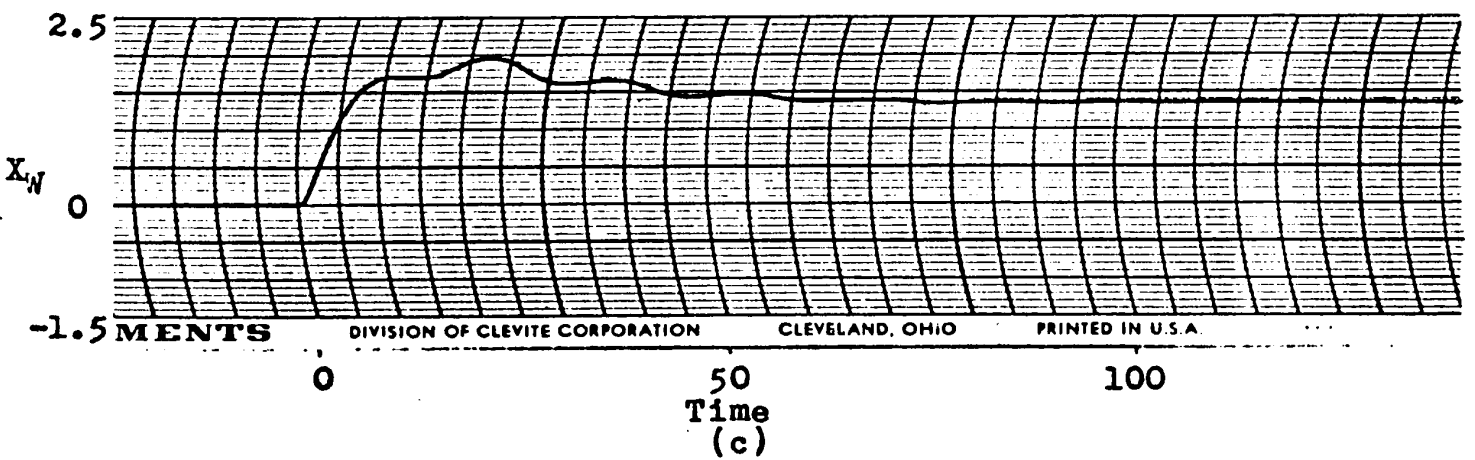
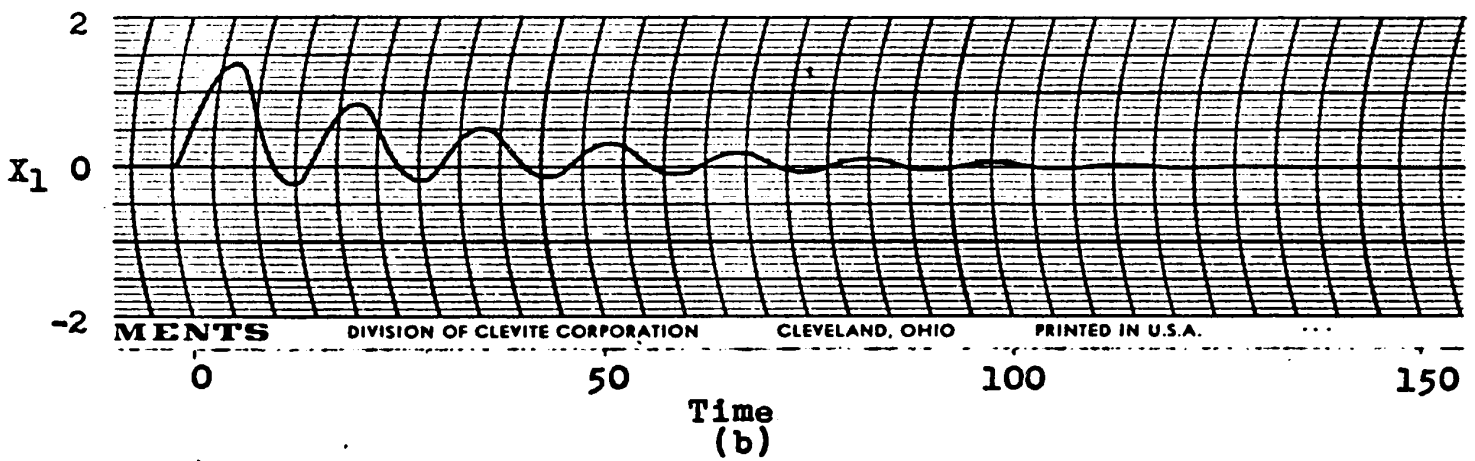
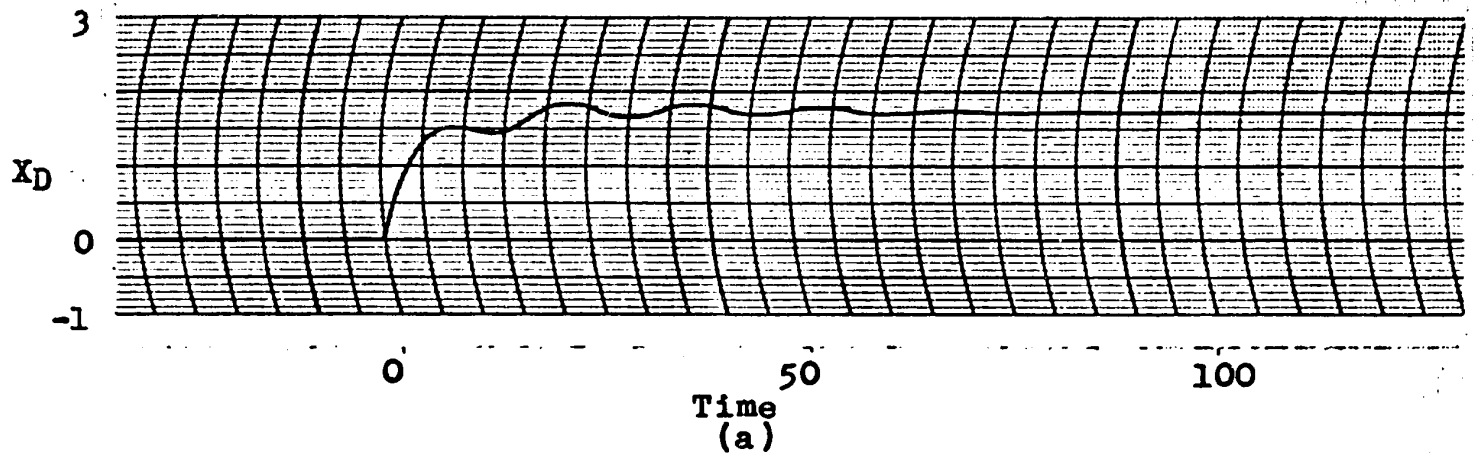

Figure 22. Response of control plate and product compositions when the sensor is on plate 1.

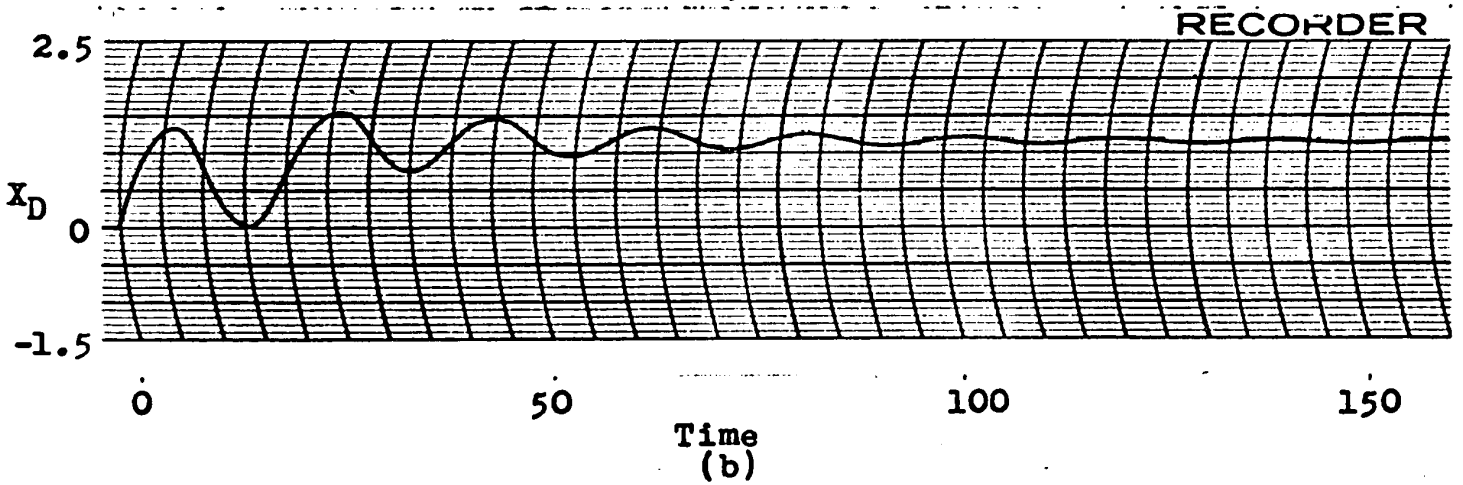
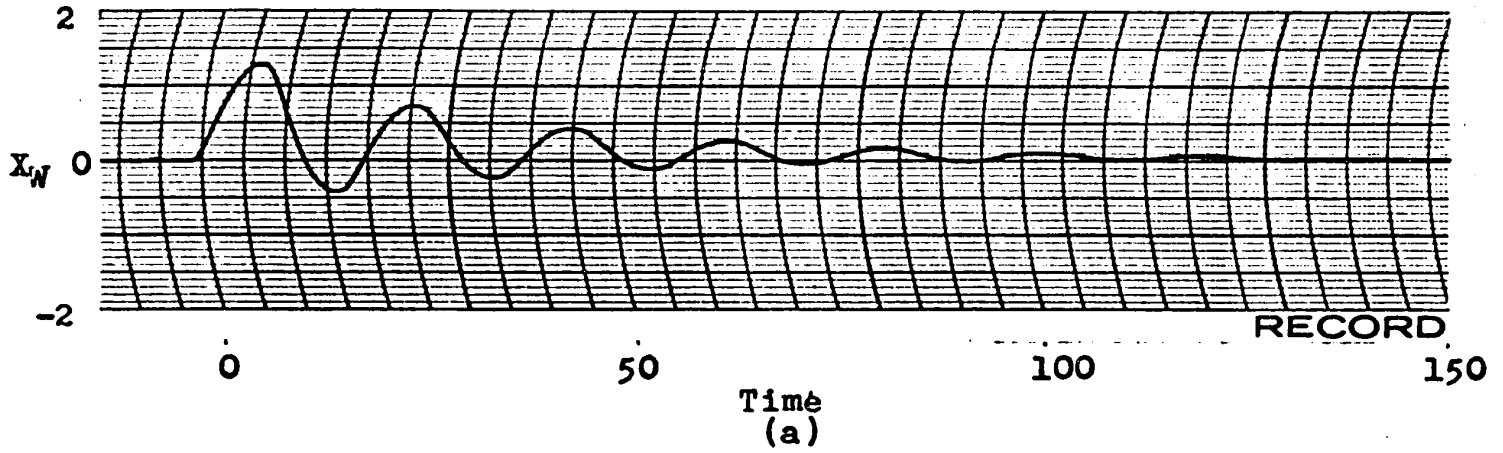

Figure 23. Response of product compositions when the sensor is in the bottom product.

II INSTANTANEOUS FEEDFORWARD PLUS FEEDBACK CONTROL

- A) Control criterion: minimize $\int_0^{\infty} e^2 dt$ for the control plate
Manipulative control: reflux rate

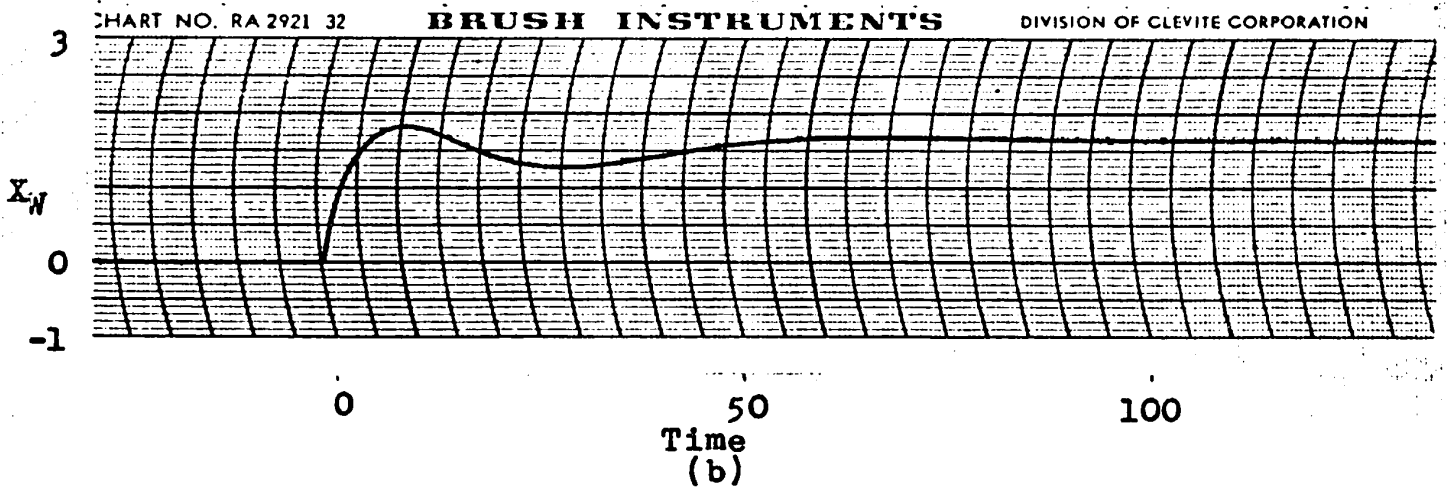
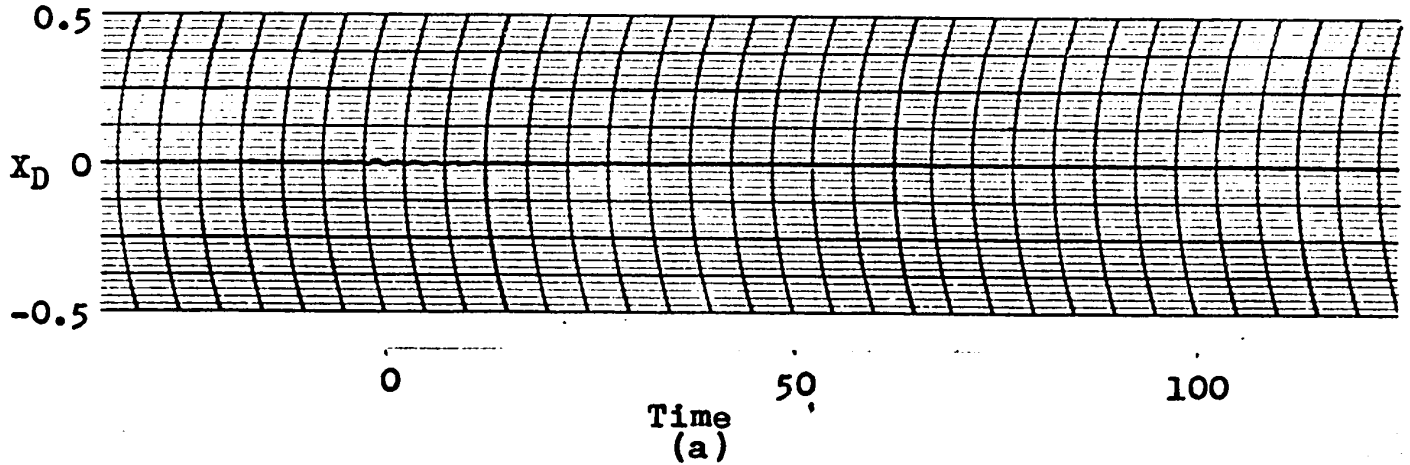

Figure 24. Response of product compositions when the sensor is in the top product.

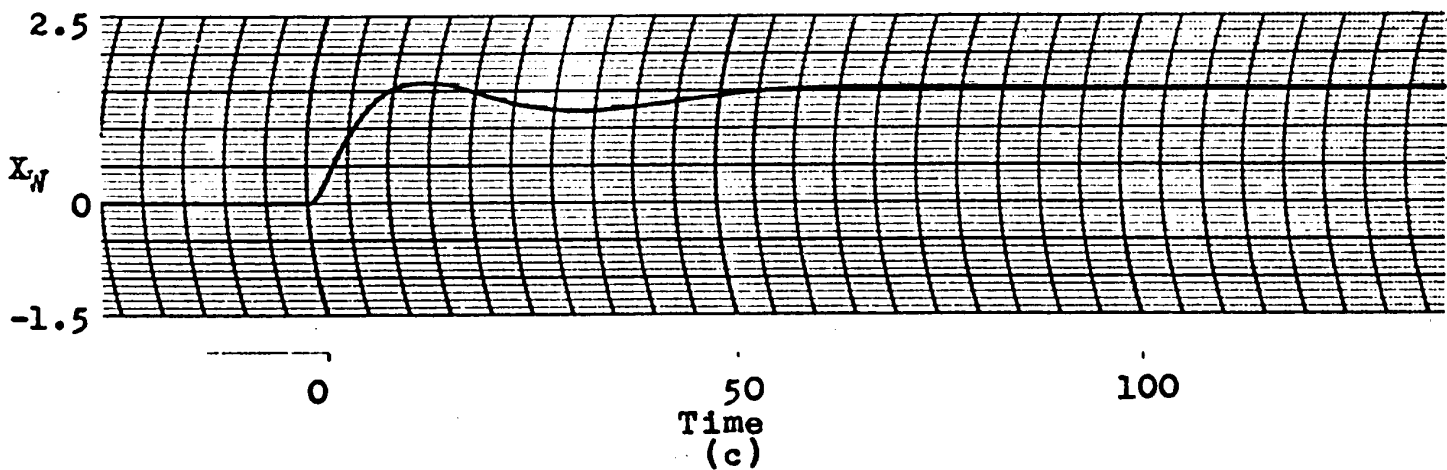
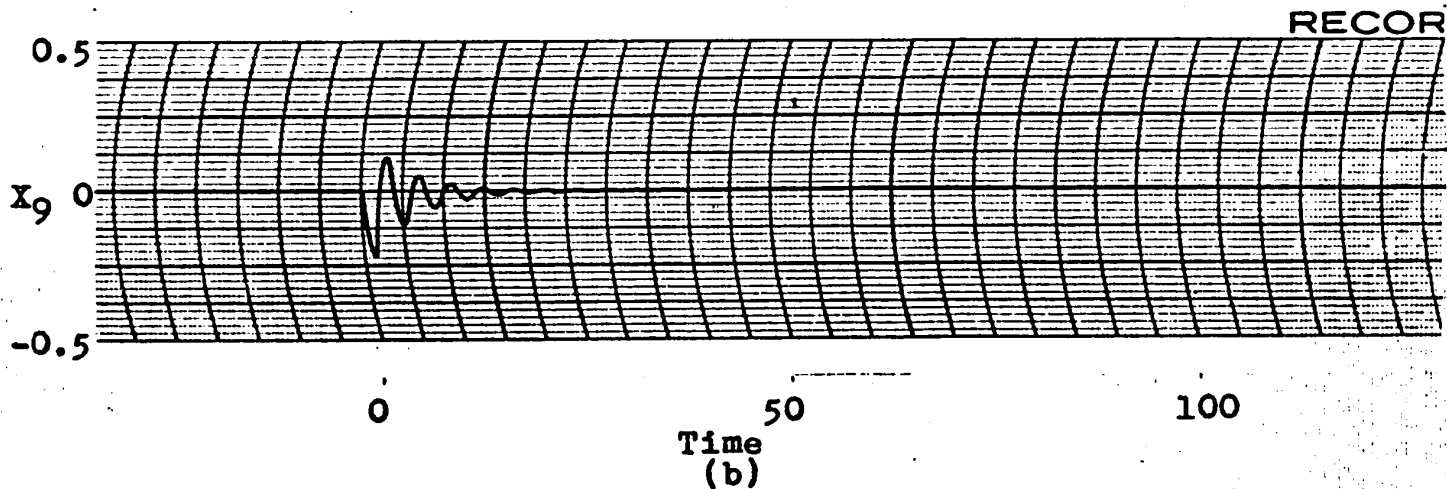
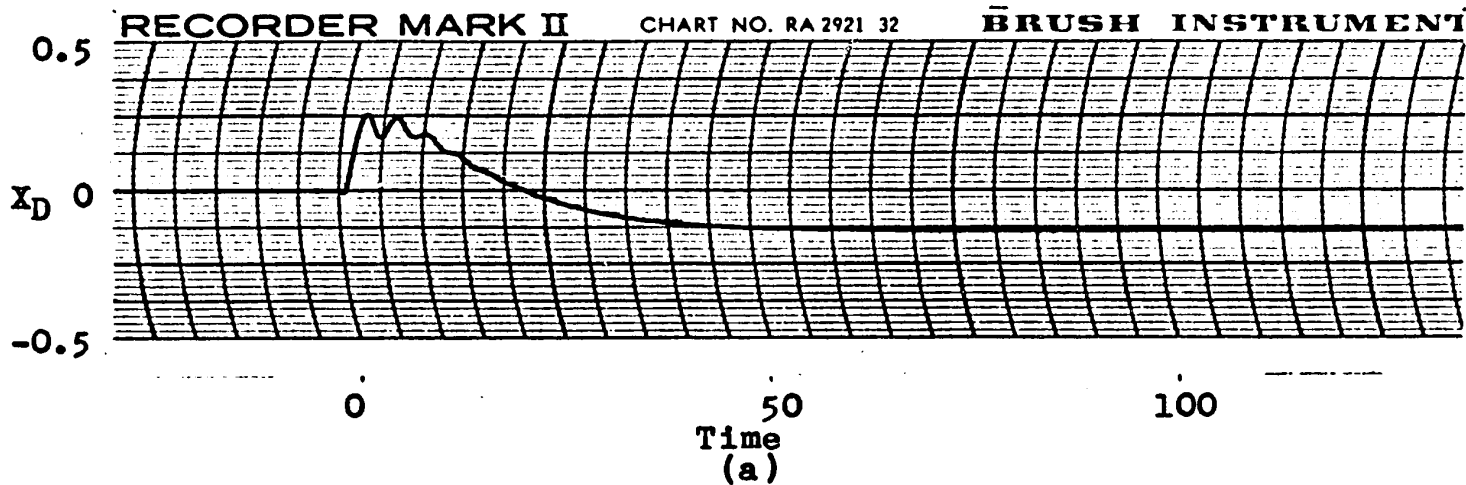
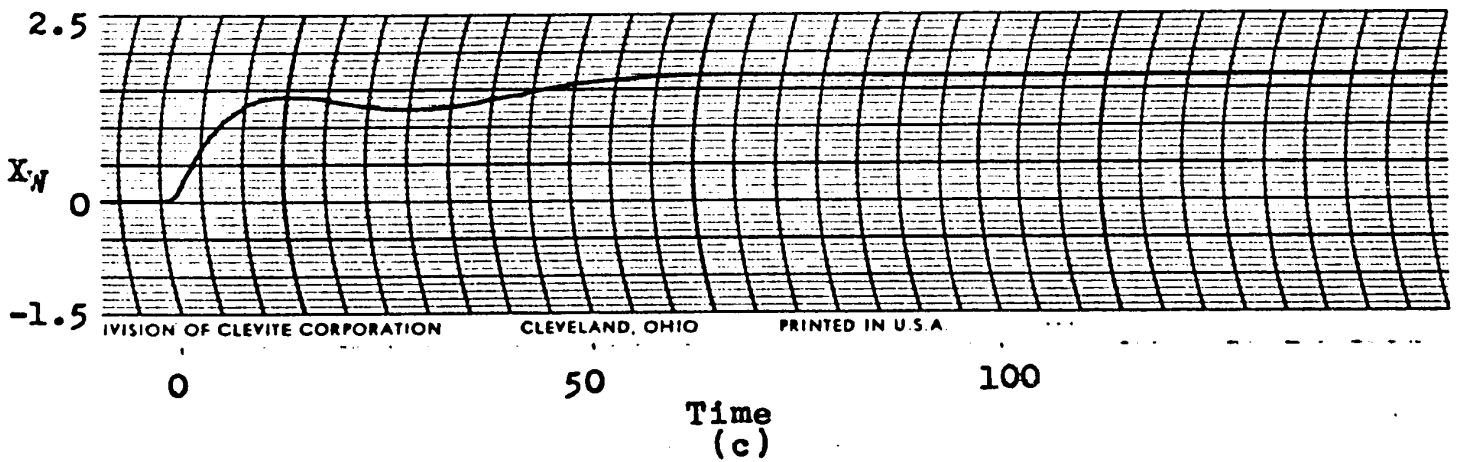
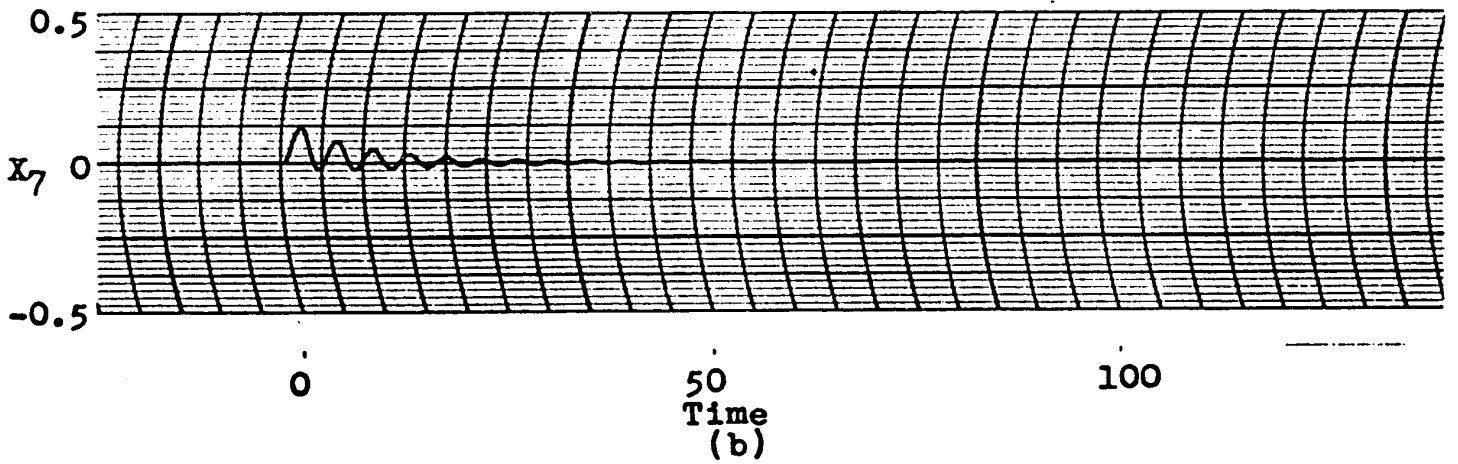
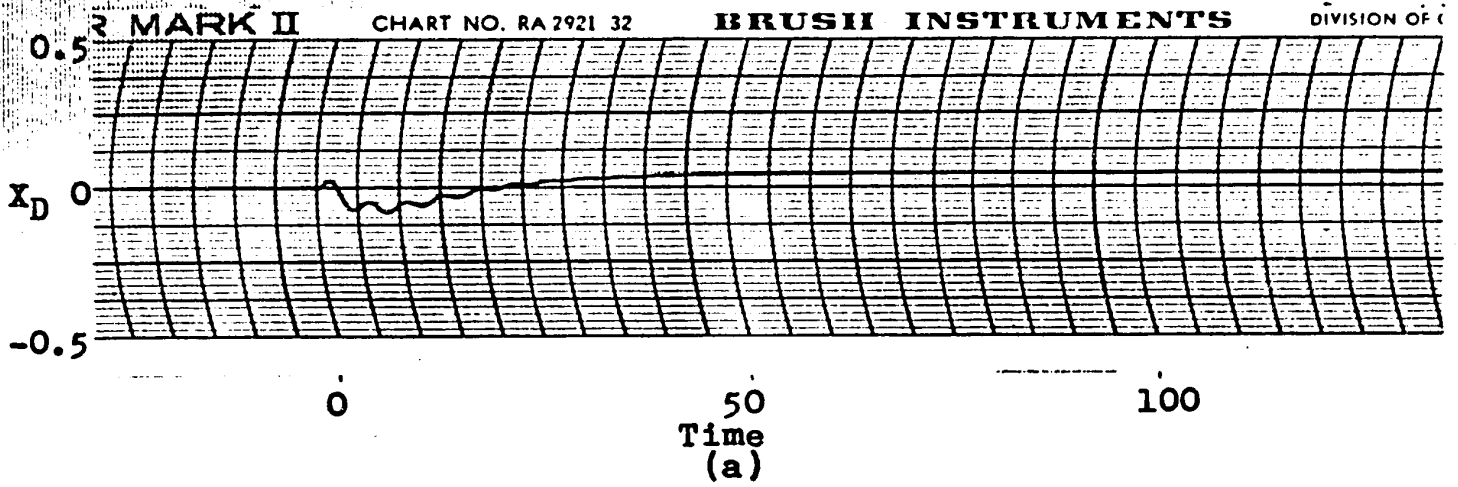

Figure 25. Response of control plate and product compositions when the sensor is on plate 9.



DIVISION OF CLEVITE CORPORATION CLEVELAND, OHIO PRINTED IN U.S.A.

Figure 26. Response of control plate and product compositions when the sensor is on plate 7.

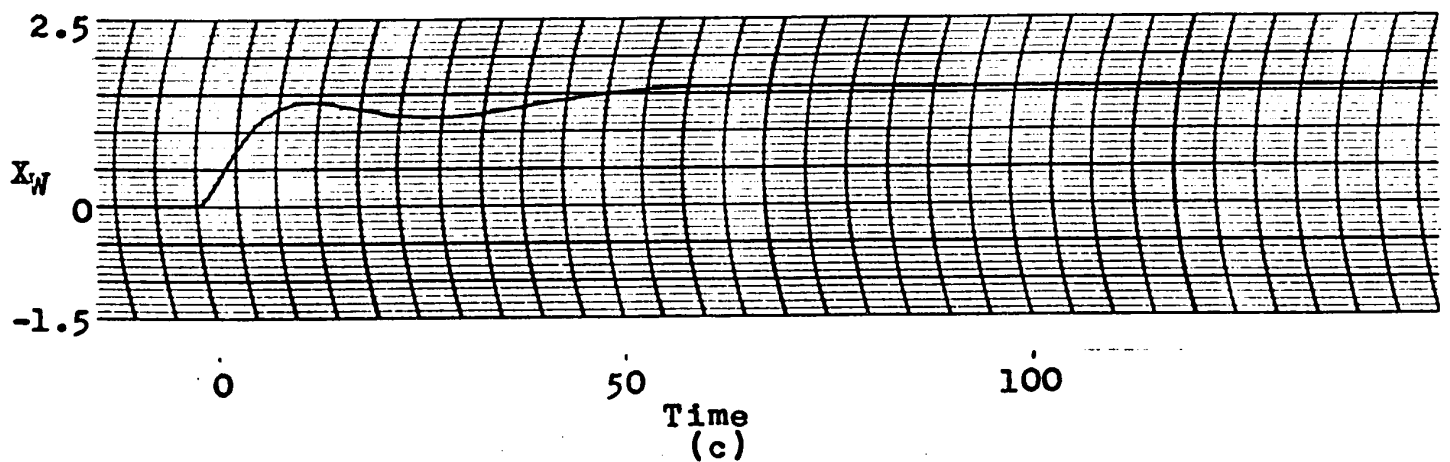
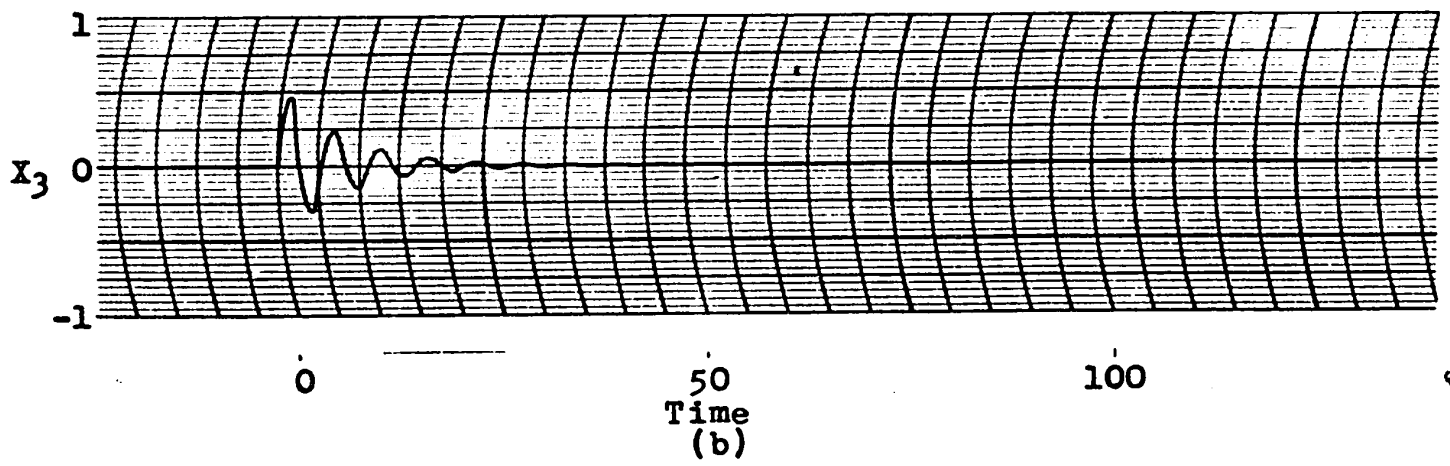
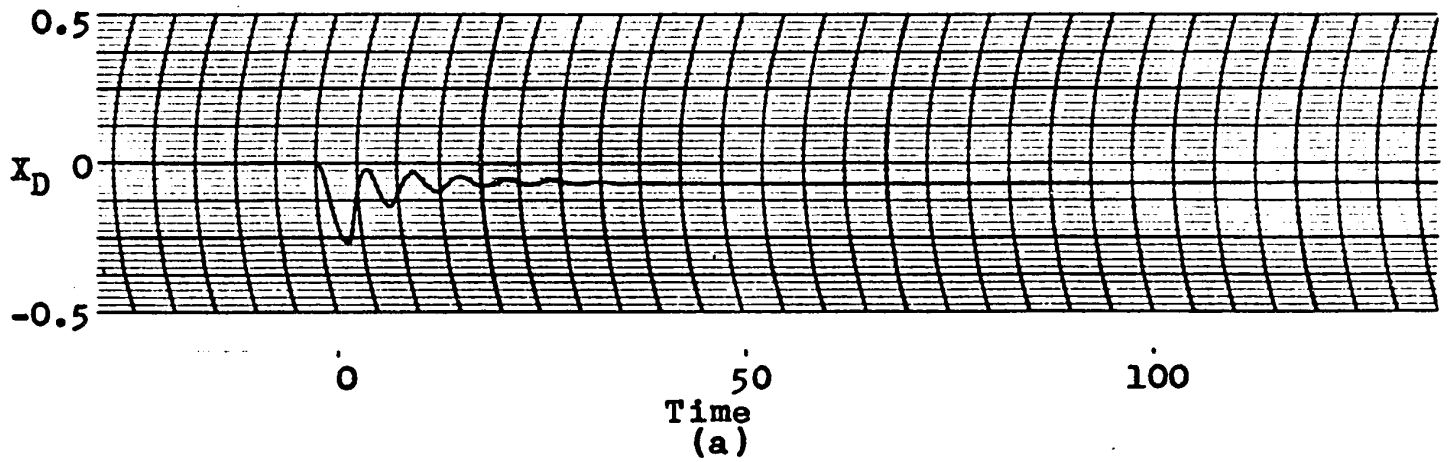

Figure 27. Response of control plate and product compositions when the sensor is on plate 3.

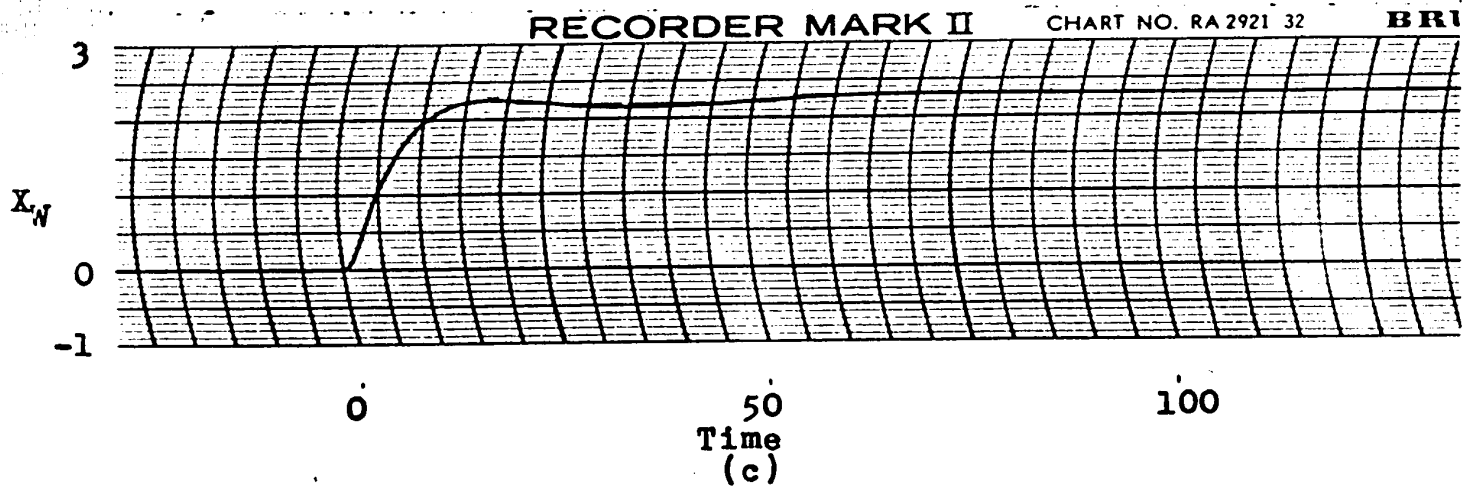
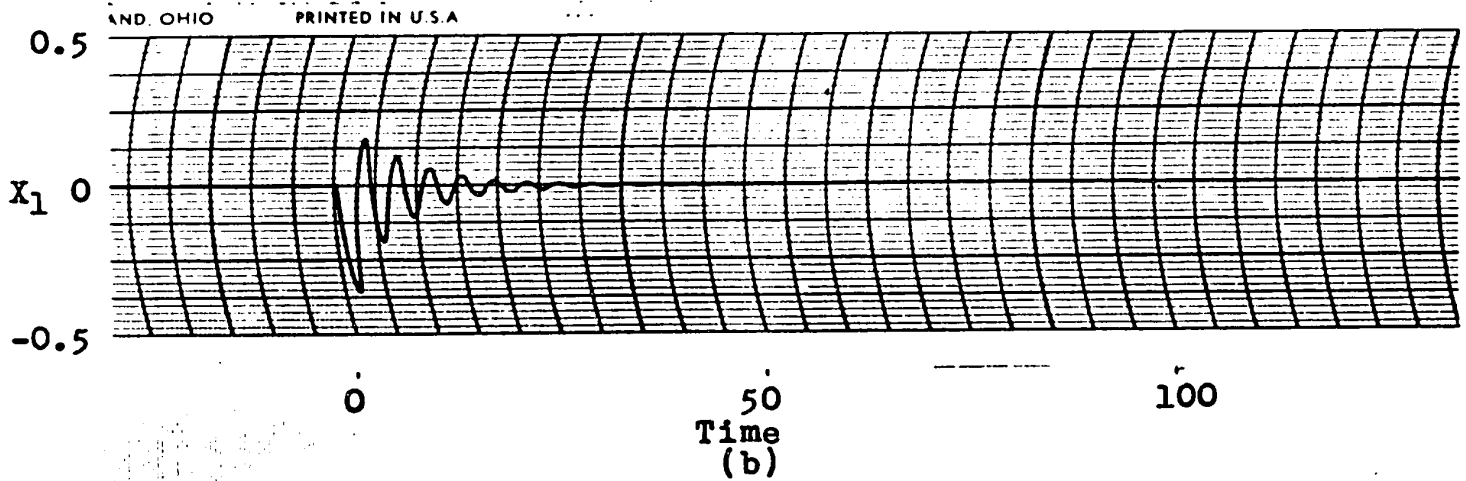
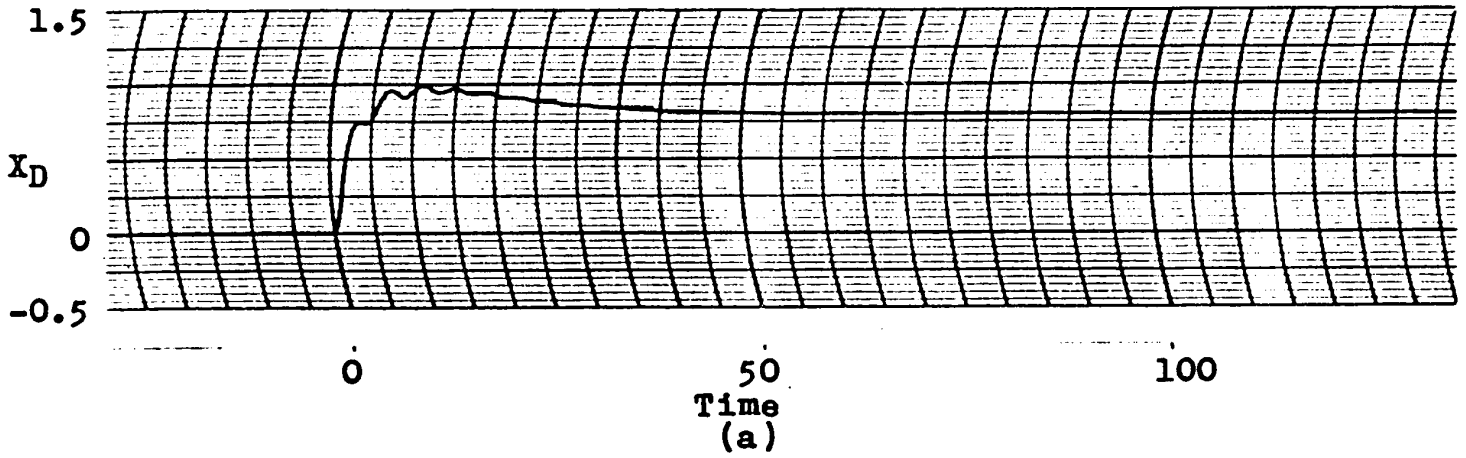

Figure 28. Response of control plate and product compositions when the sensor is on plate 1.

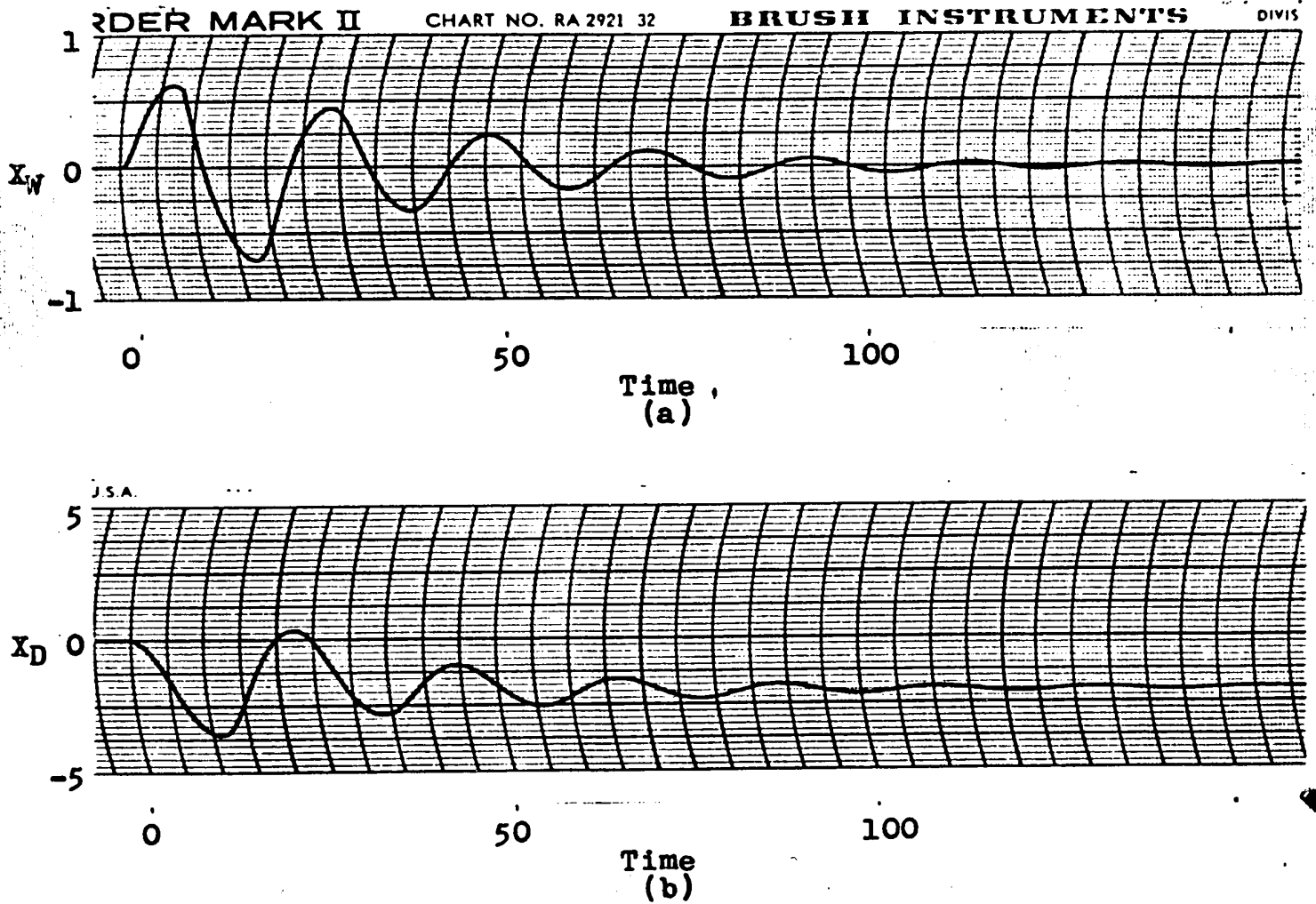

Figure 29. Response of product compositions when the sensor is in the bottom product.

B) Control criterion: minimize $\int e^2 dt$ for the control plate
Manipulative control: reboil vapour rate

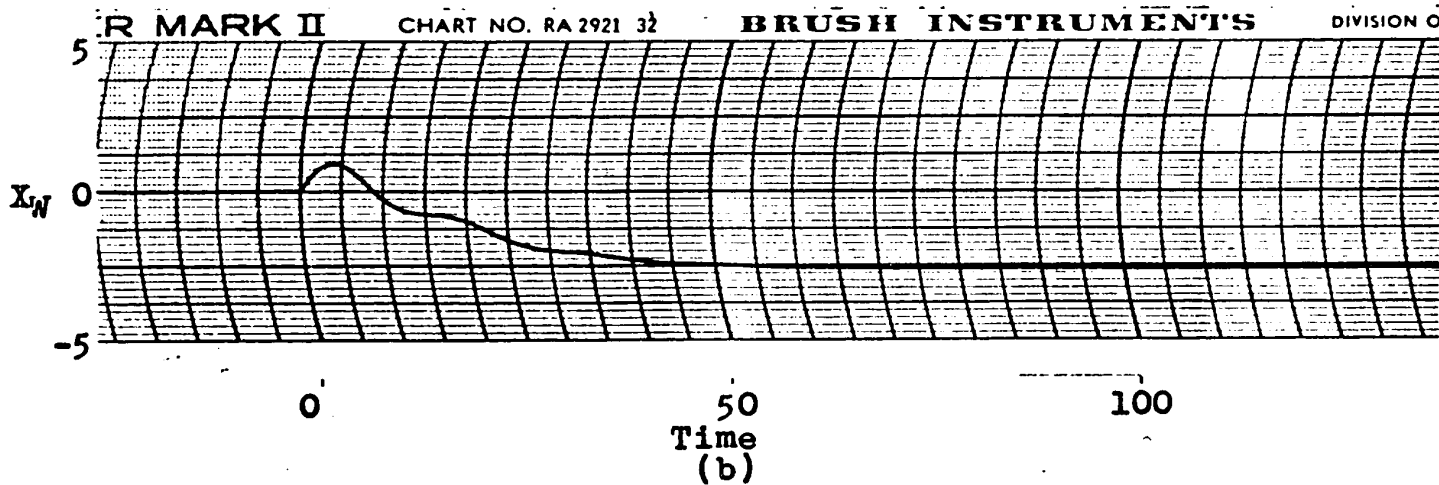
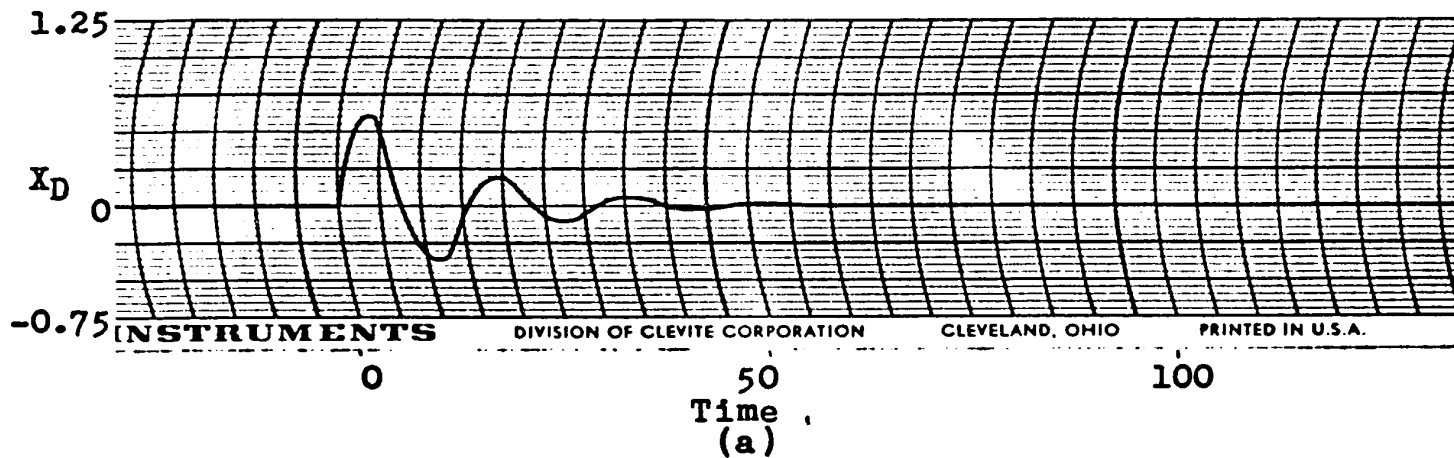

Figure 30. Response of product compositions when the sensor is in the top product.

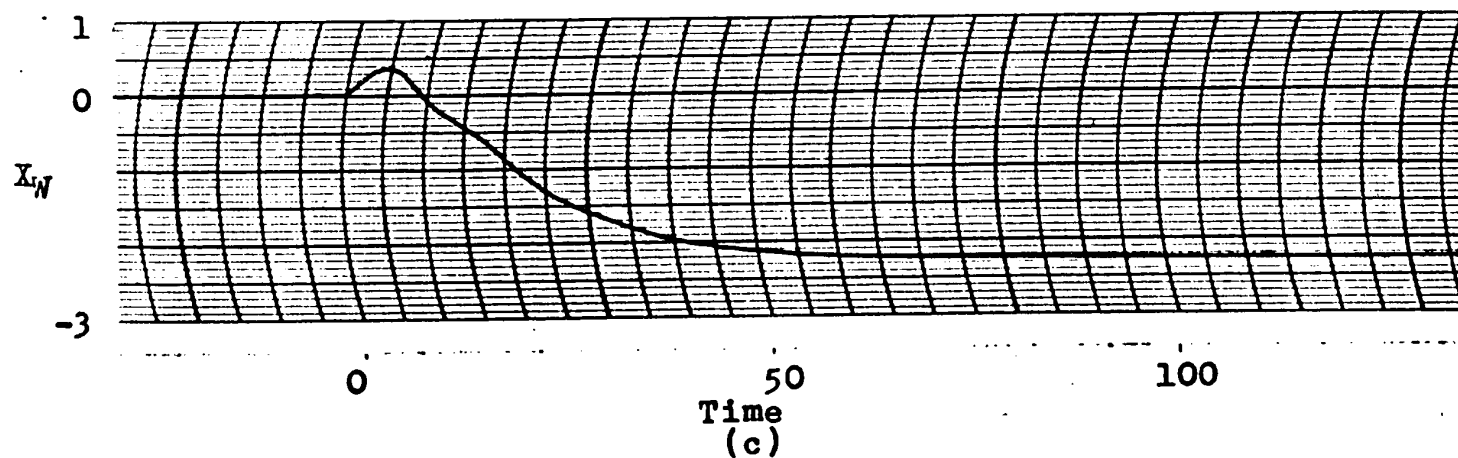
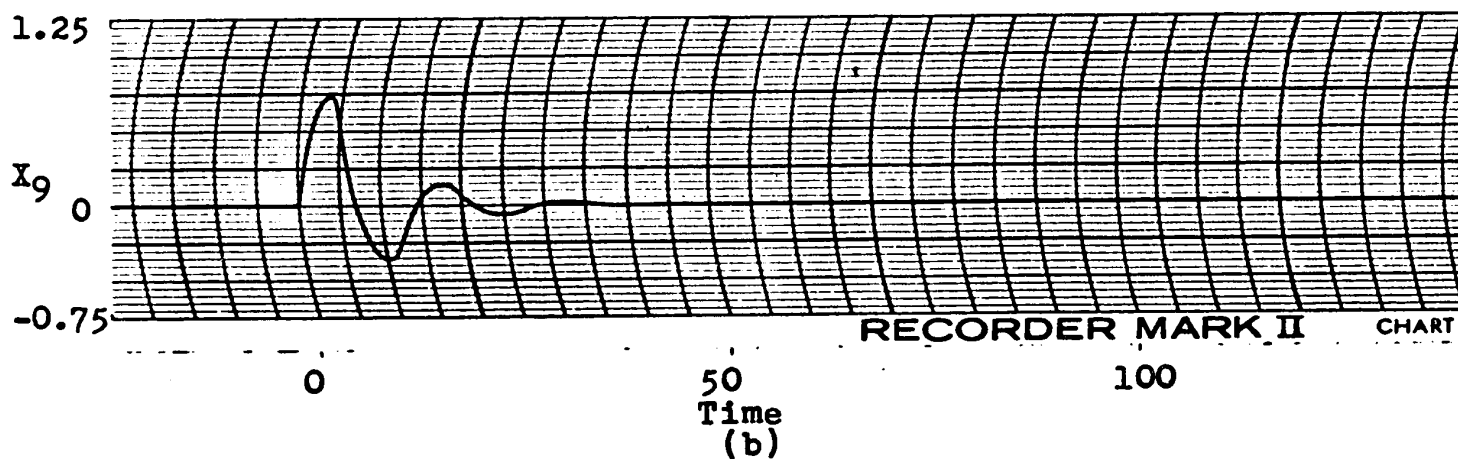
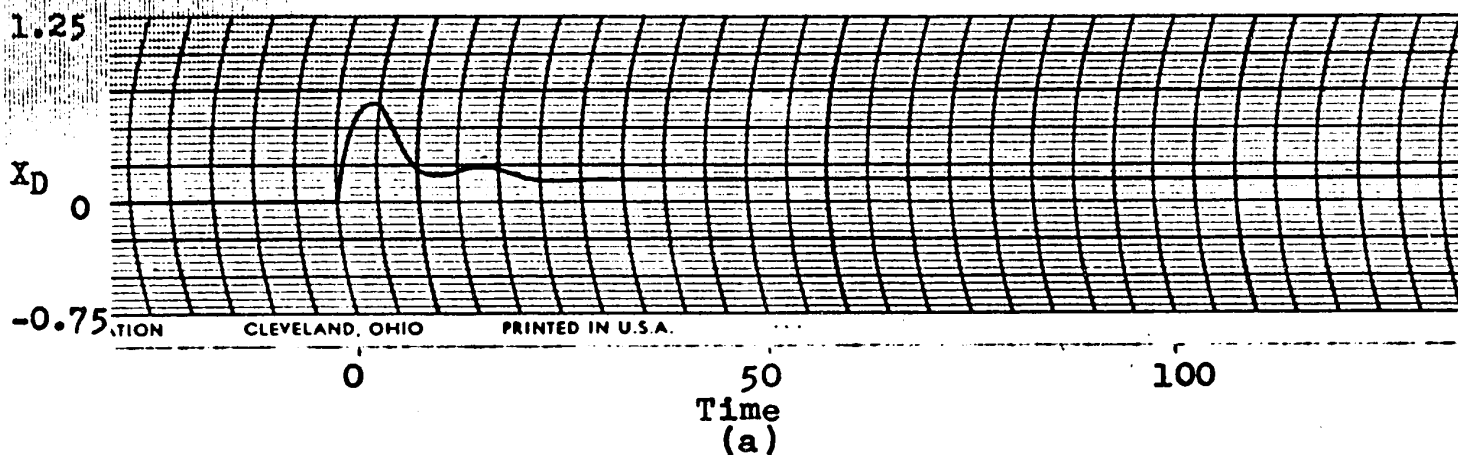

Figure 31. Response of control plate and product compositions when the sensor is on plate 9.

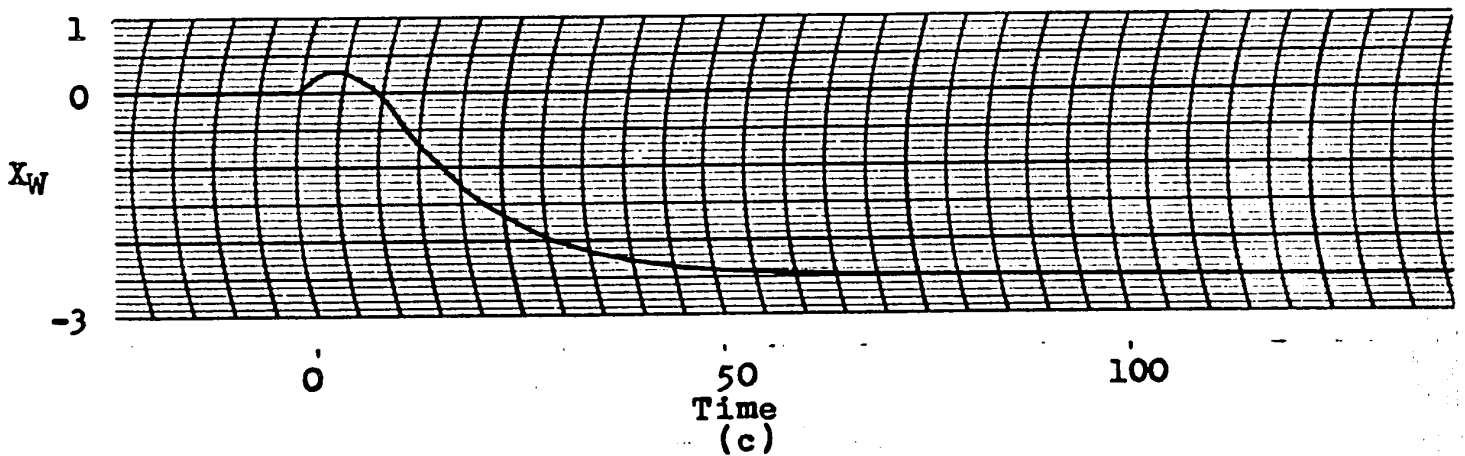
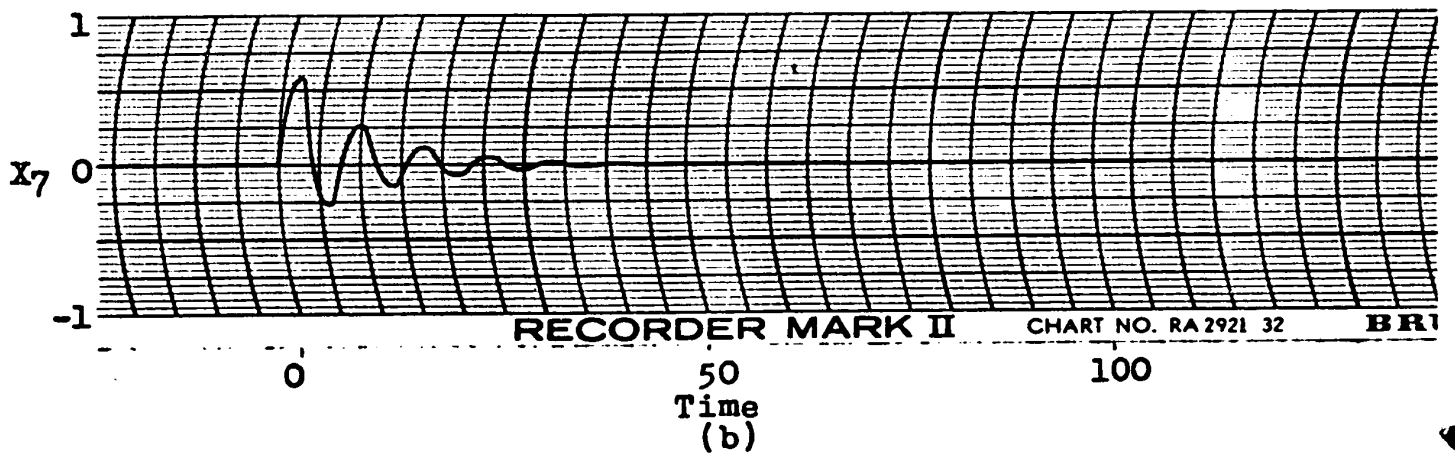
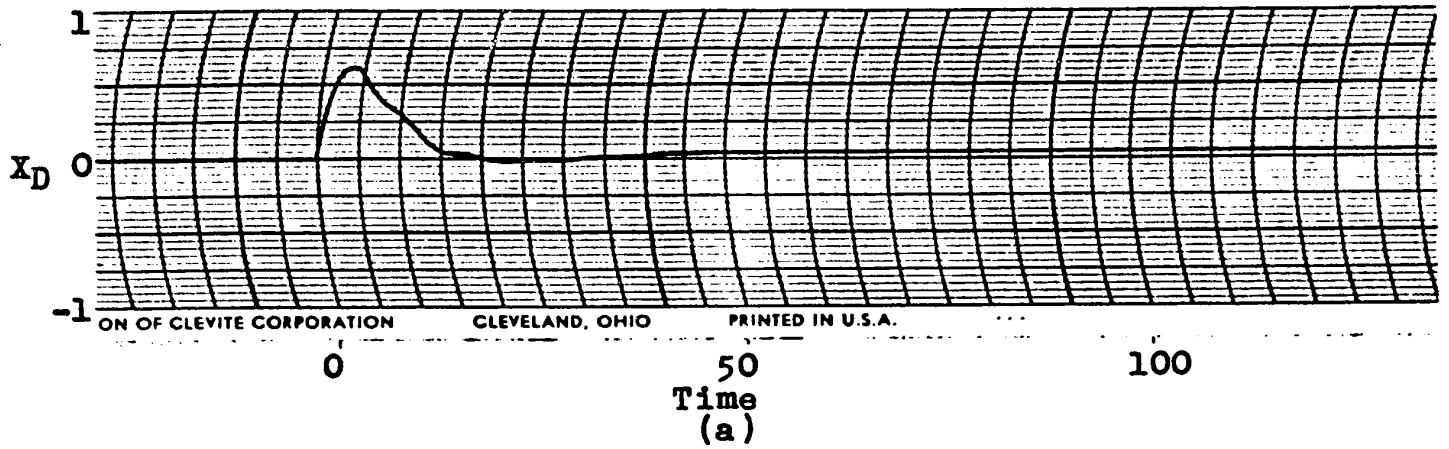

Figure 32. Response of control plate and product compositions when the sensor is on plate 7.

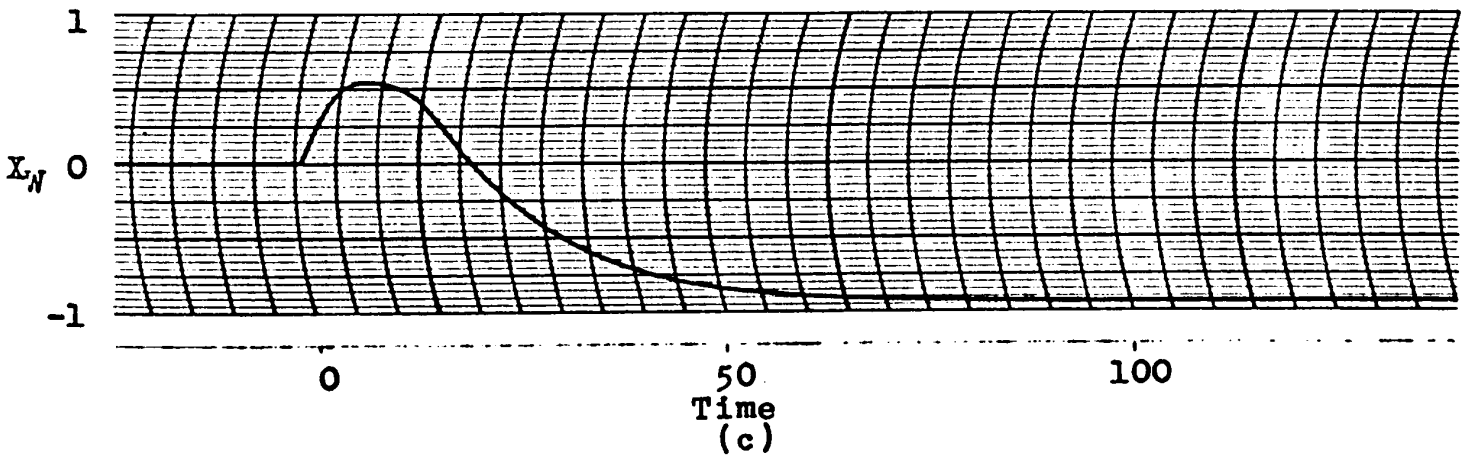
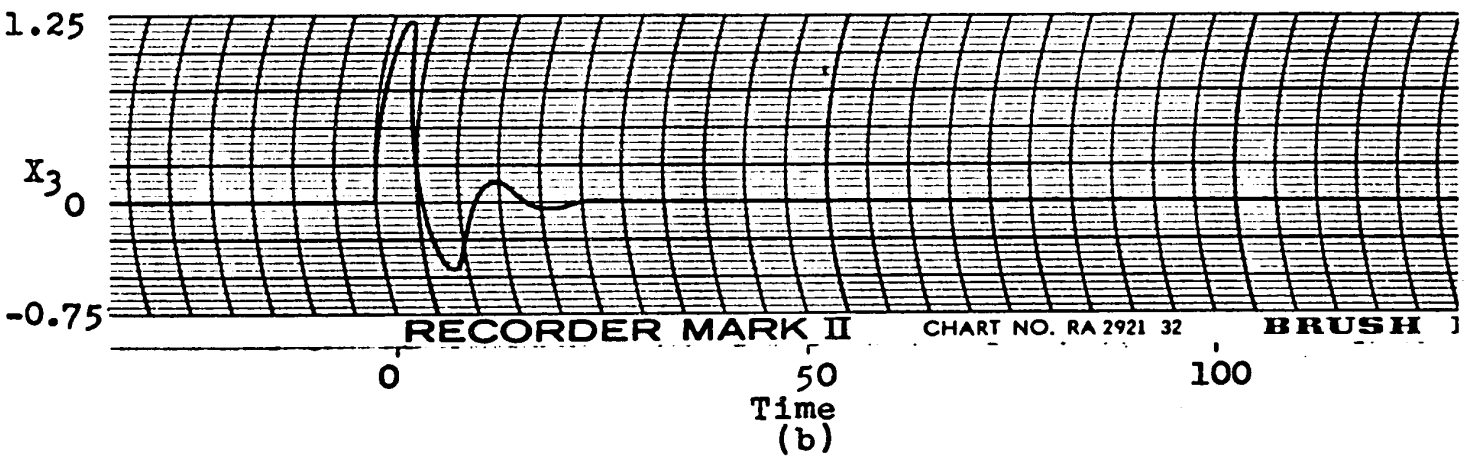
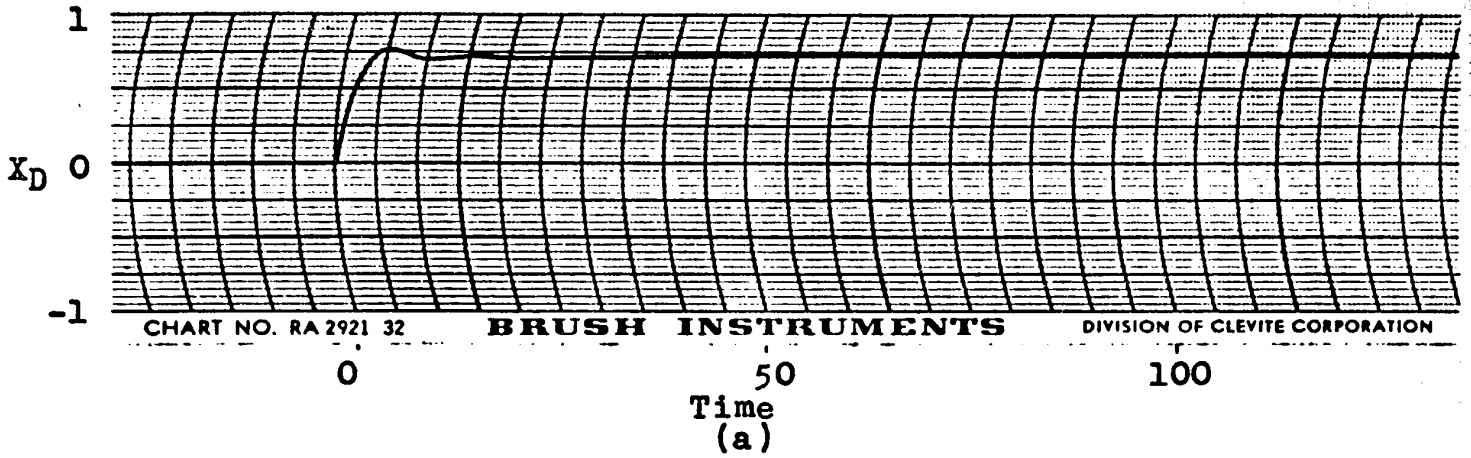

Figure 33. Response of control plate and product compositions when the sensor is on plate 3.

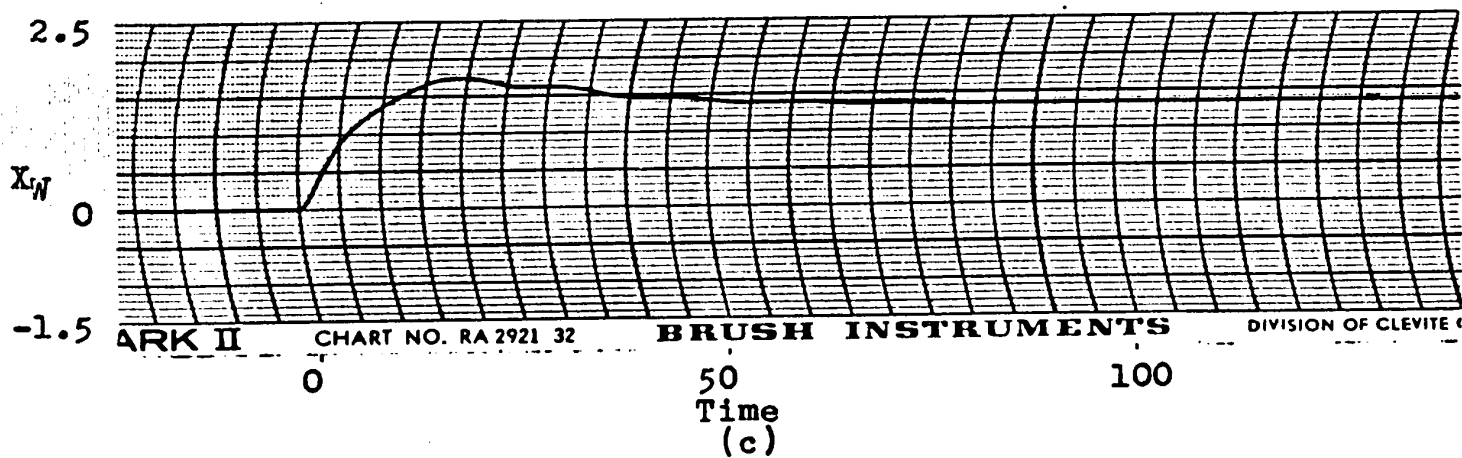
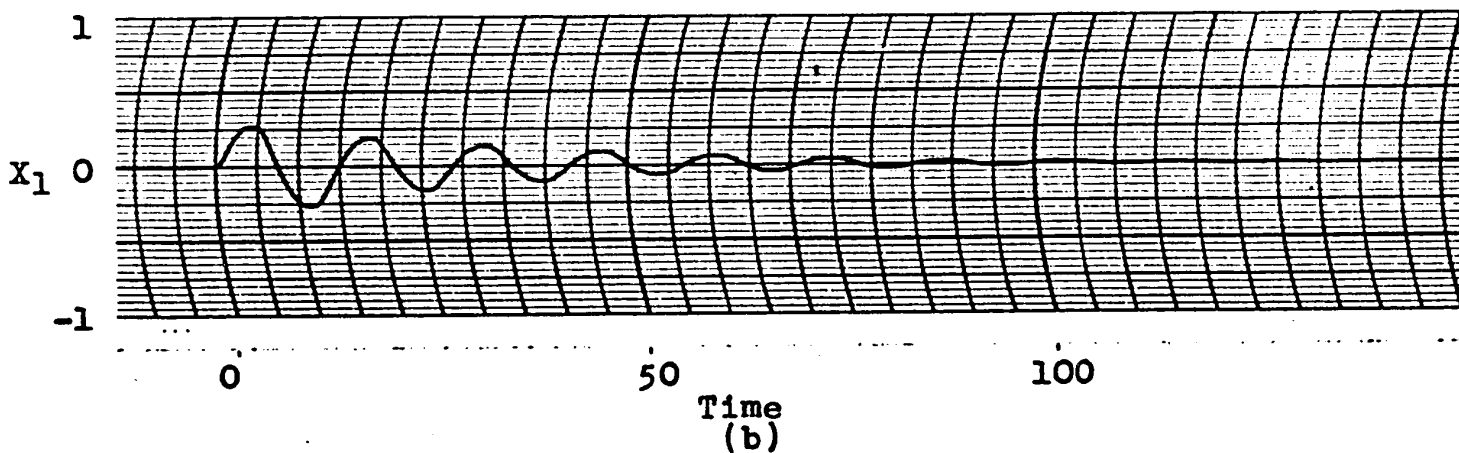
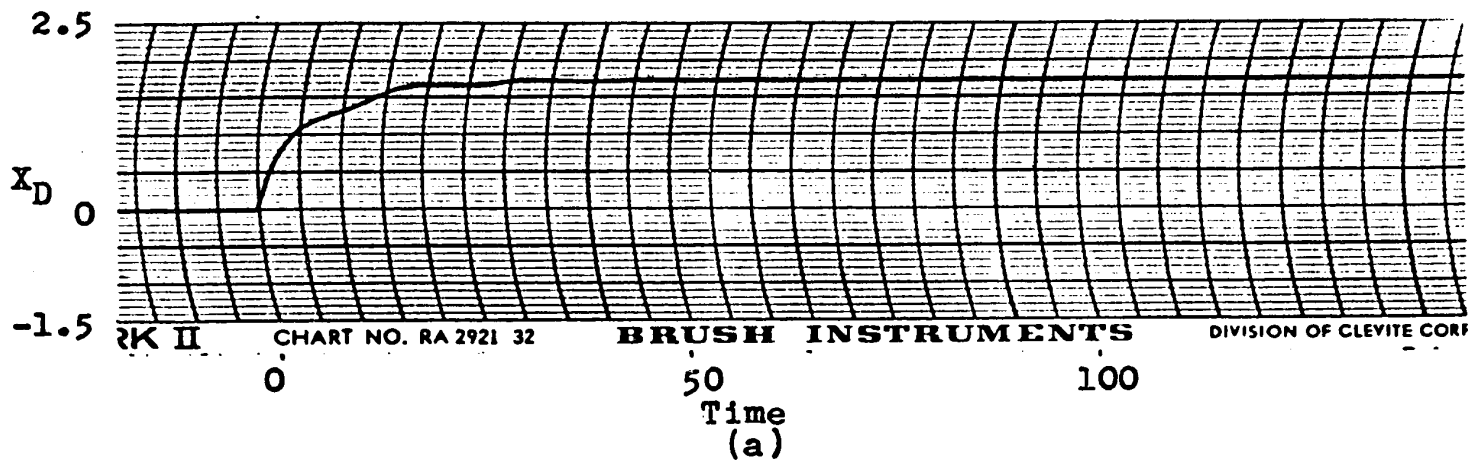

Figure 34. Response of control plate and product compositions when the sensor is on plate 1.

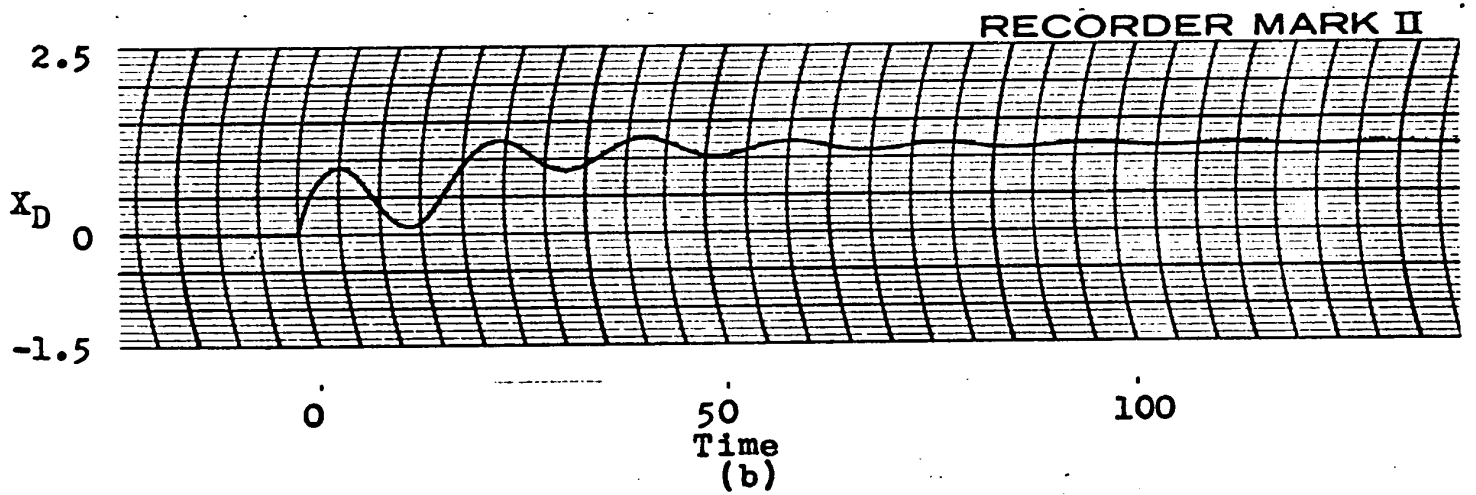
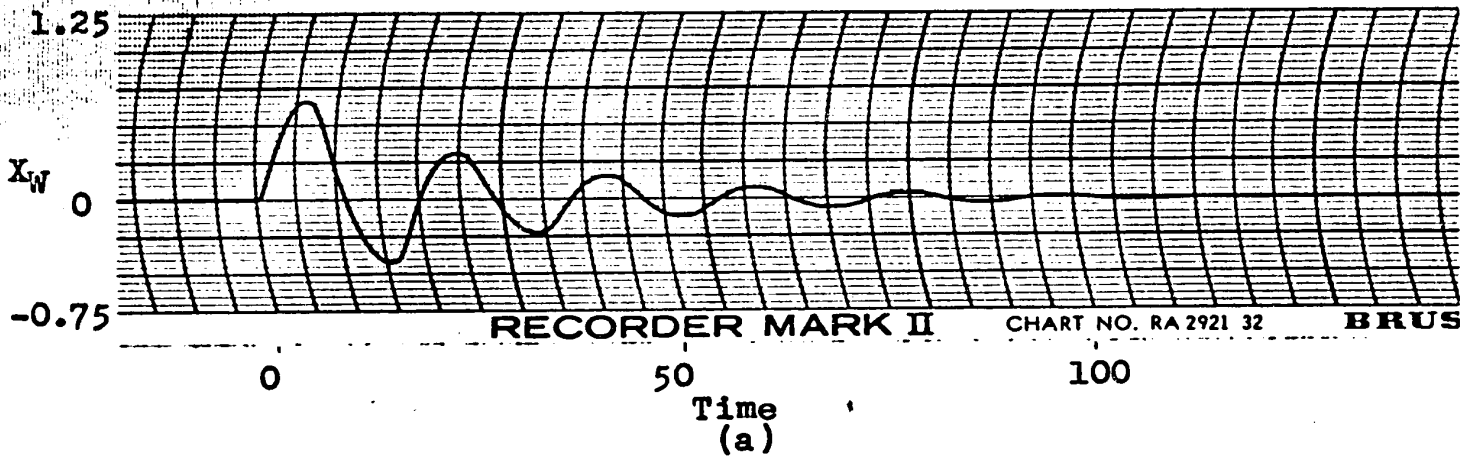

Figure 35. Response of product compositions when the sensor is in the bottom product.

C) Control criterion: minimize $\int_0^{\infty} e^2 dt$ for the top product
Manipulative control: reflux rate

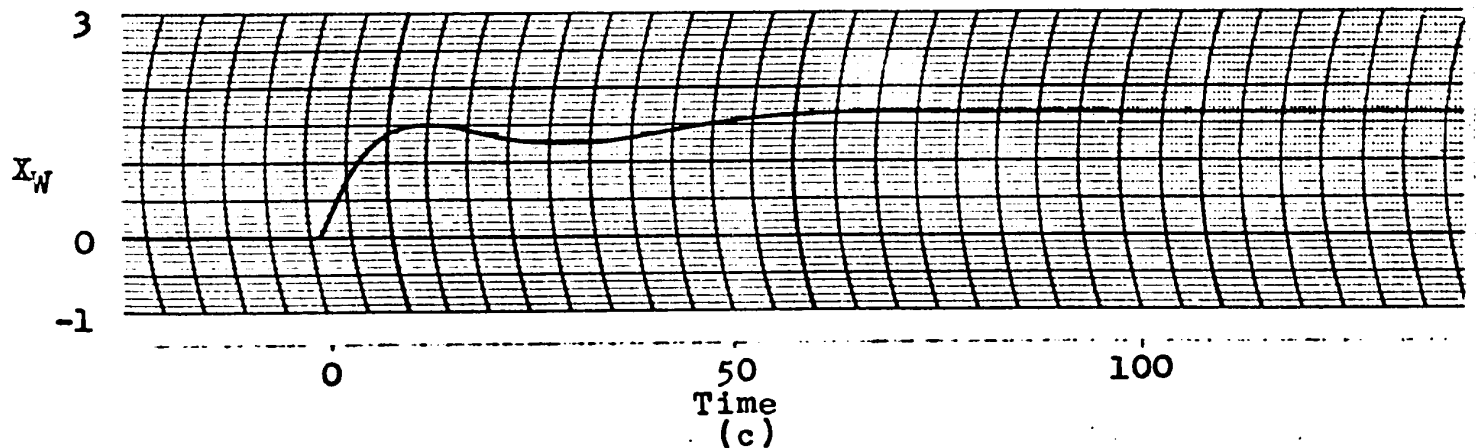
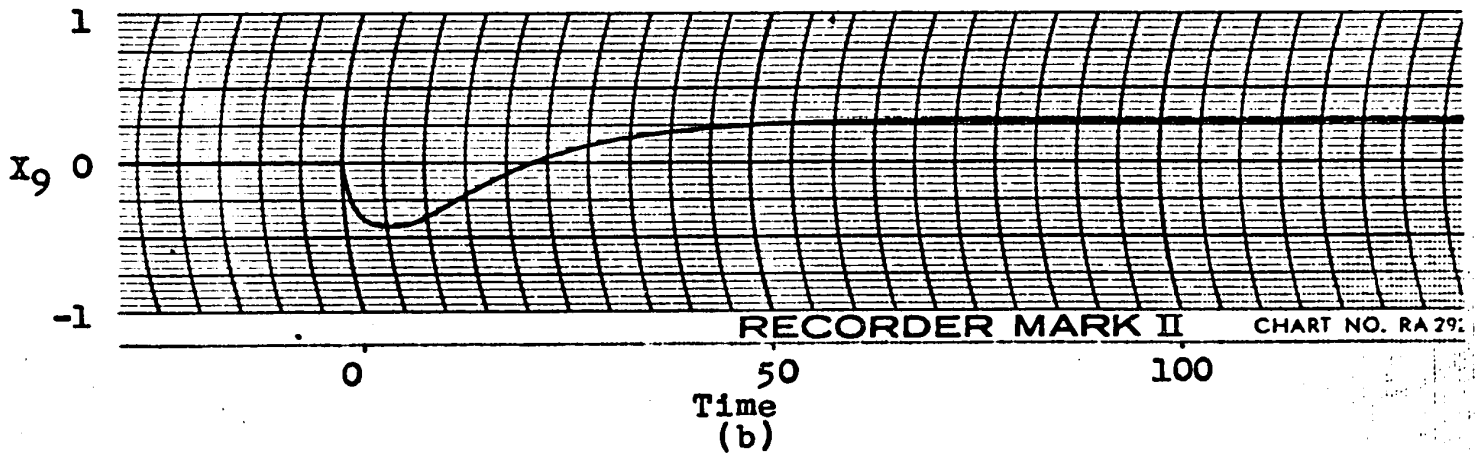
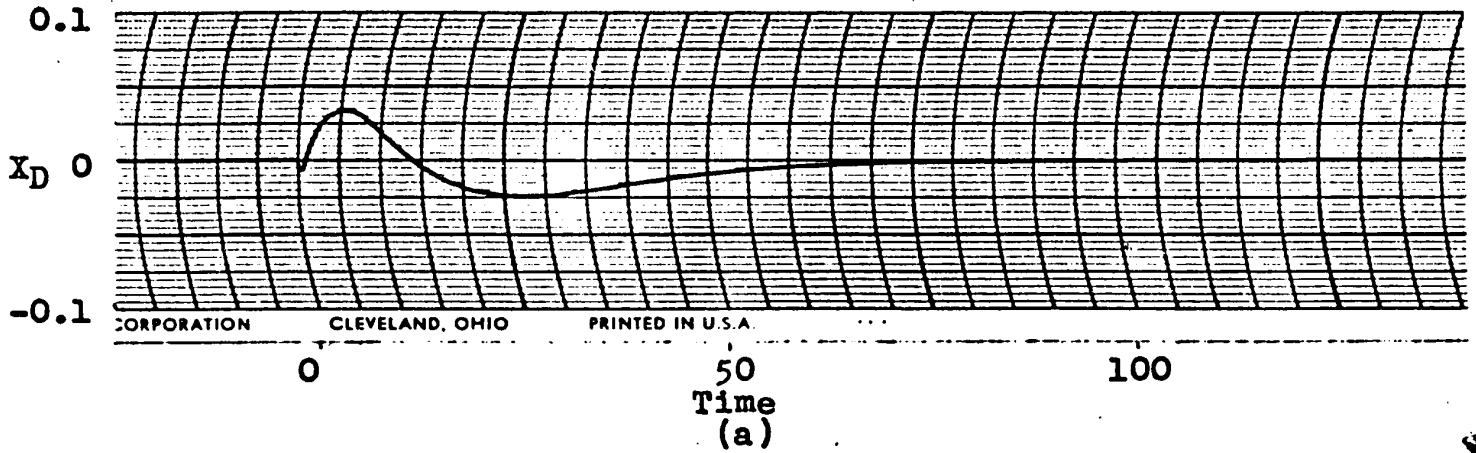

Figure 36. Response of control plate and product compositions when the sensor is on plate 9.

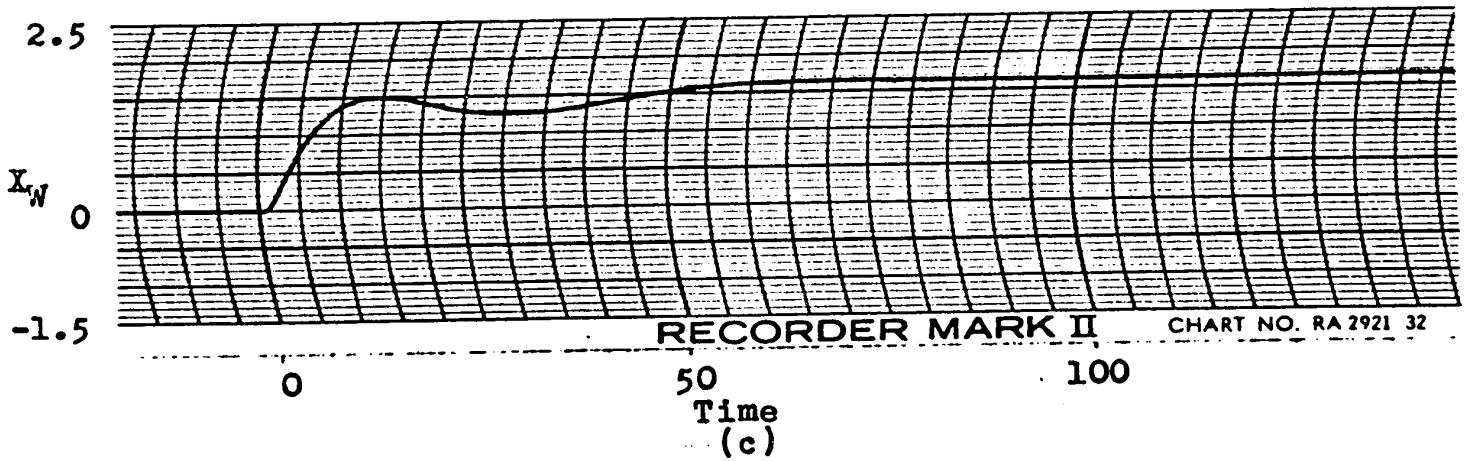
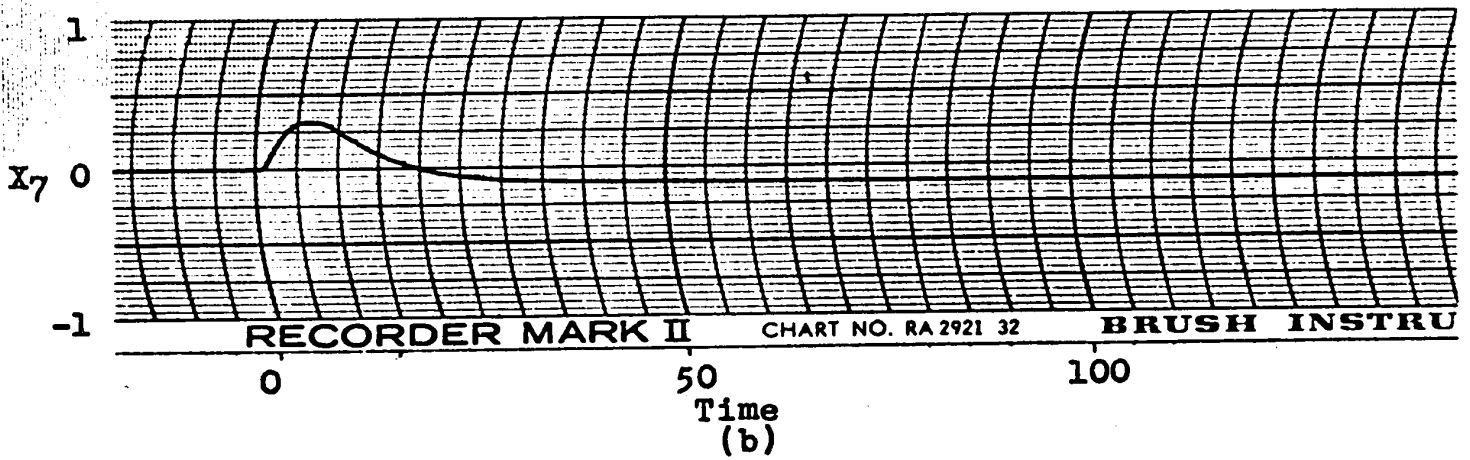
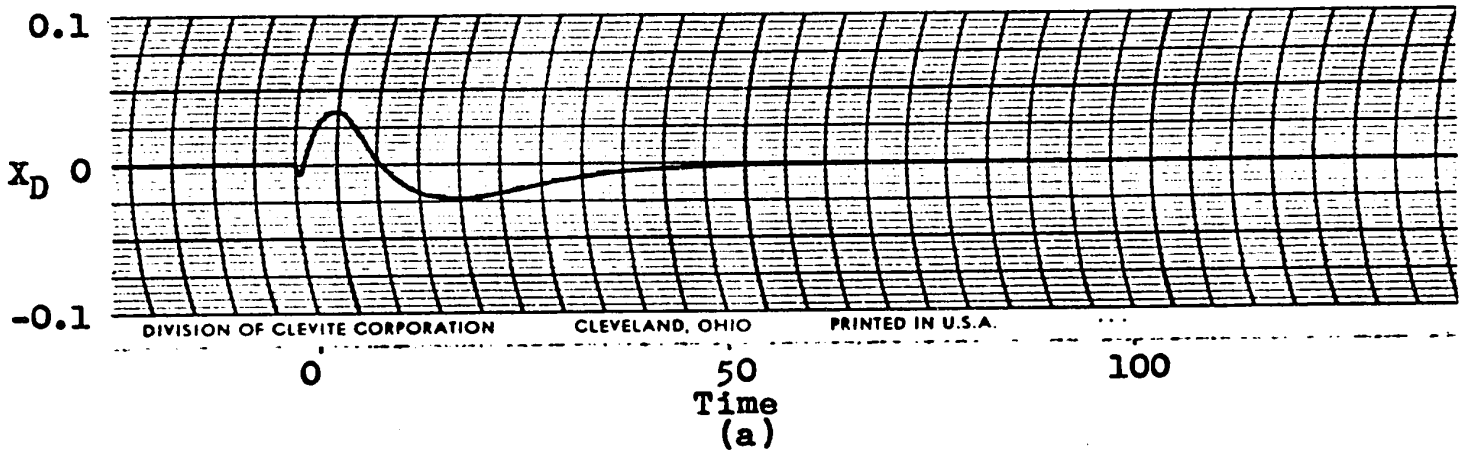

Figure 37. Response of control plate and product compositions when the sensor is on plate 7.

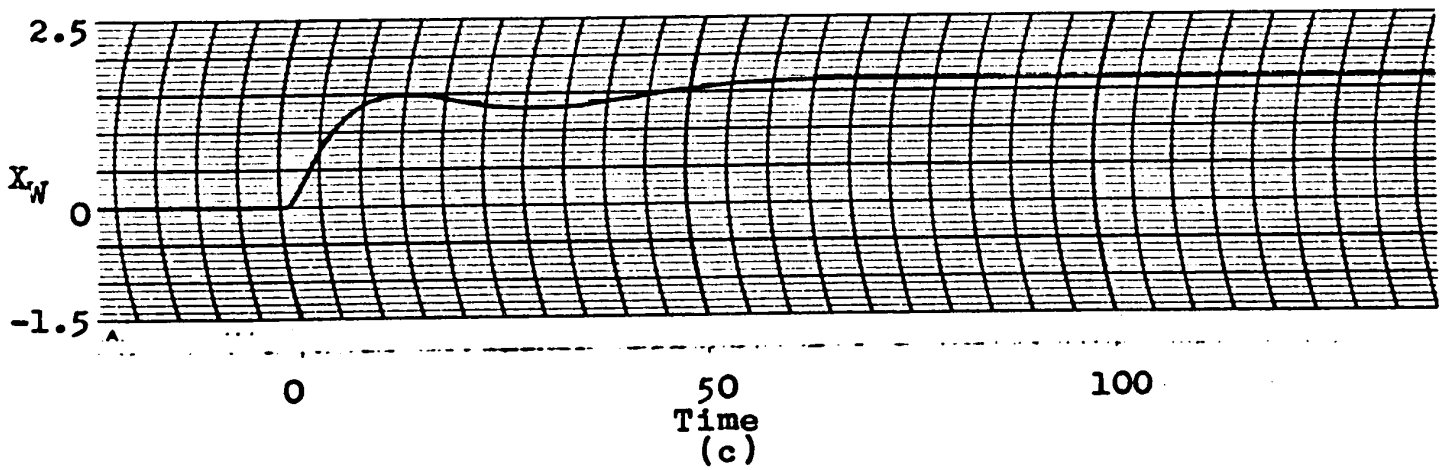
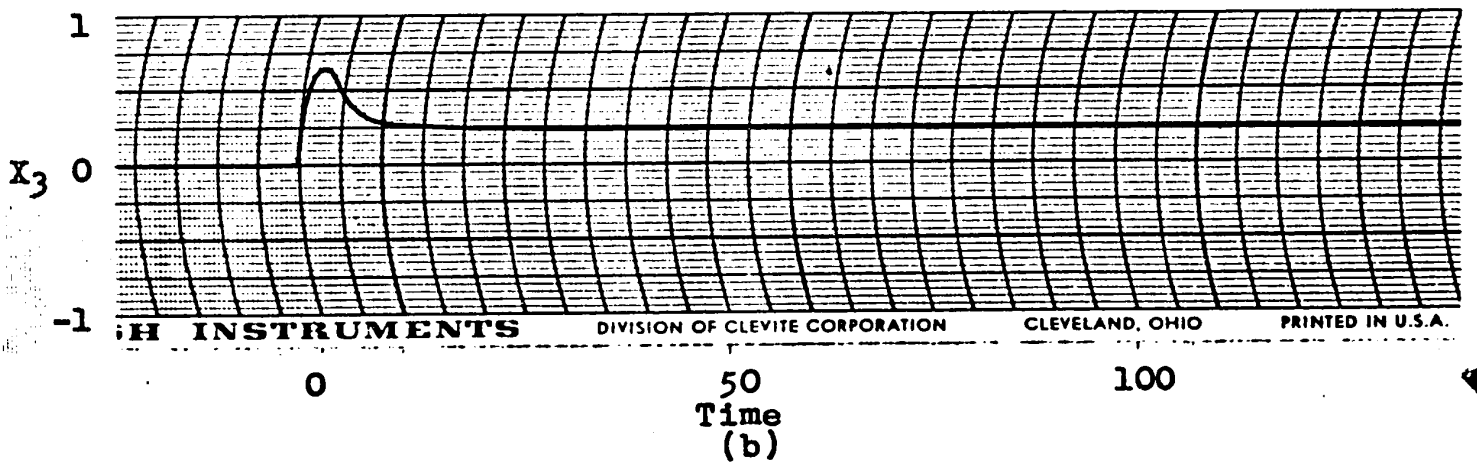
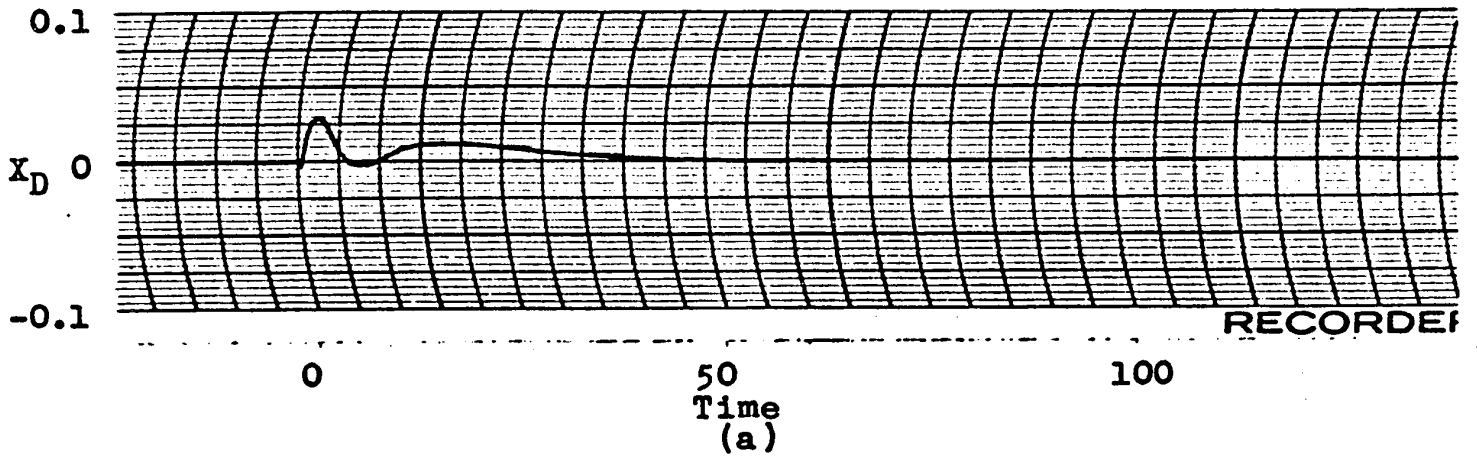

Figure 38. Response of control plate and product compositions when the sensor is on plate 3.

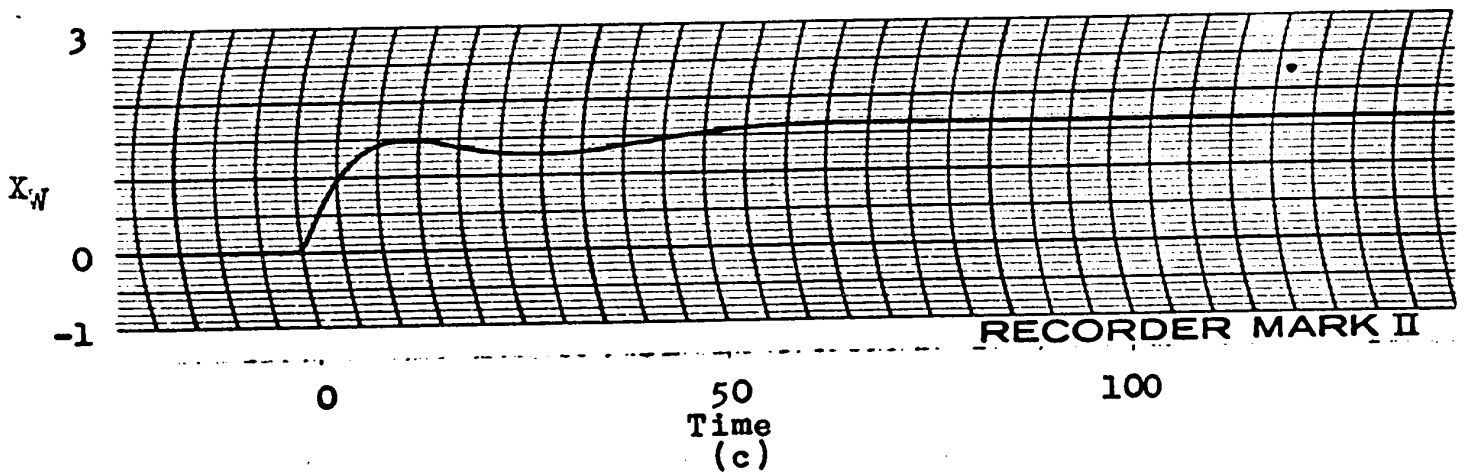
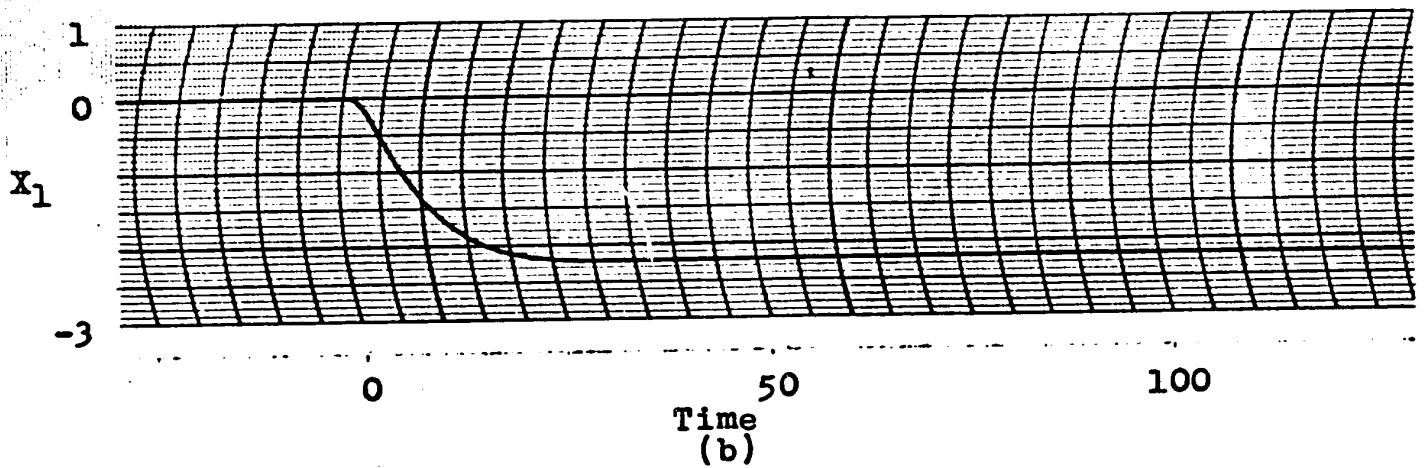
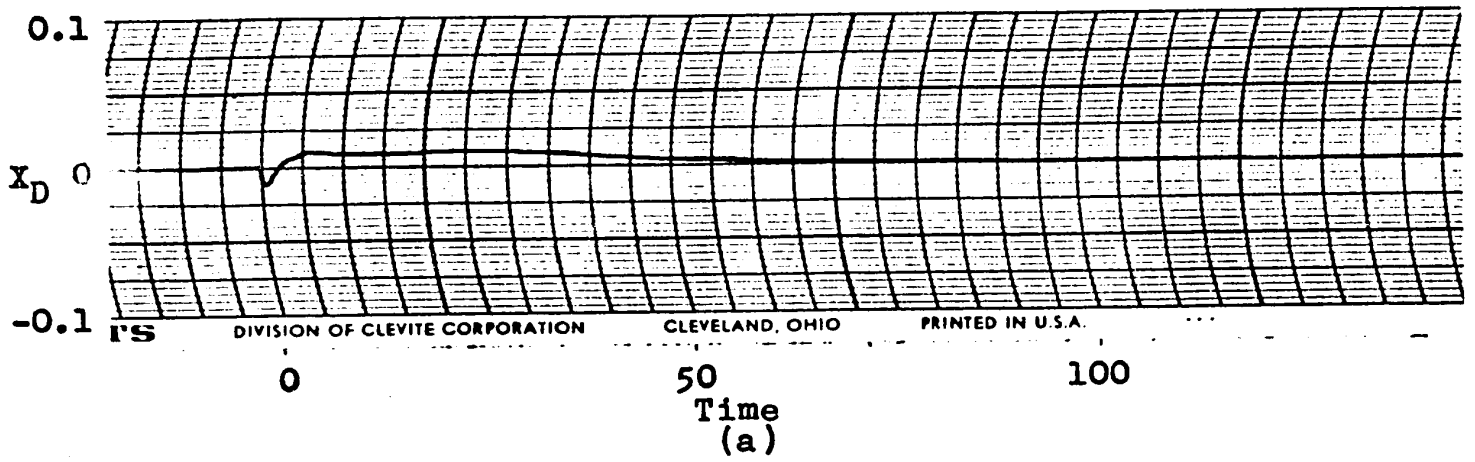

Figure 39. Response of control plate and product compositions when the sensor is on plate 1.

D) Control criterion: minimize $\int_0^T e^2 dt$ for the top product
Manipulative control: reboil vapour rate

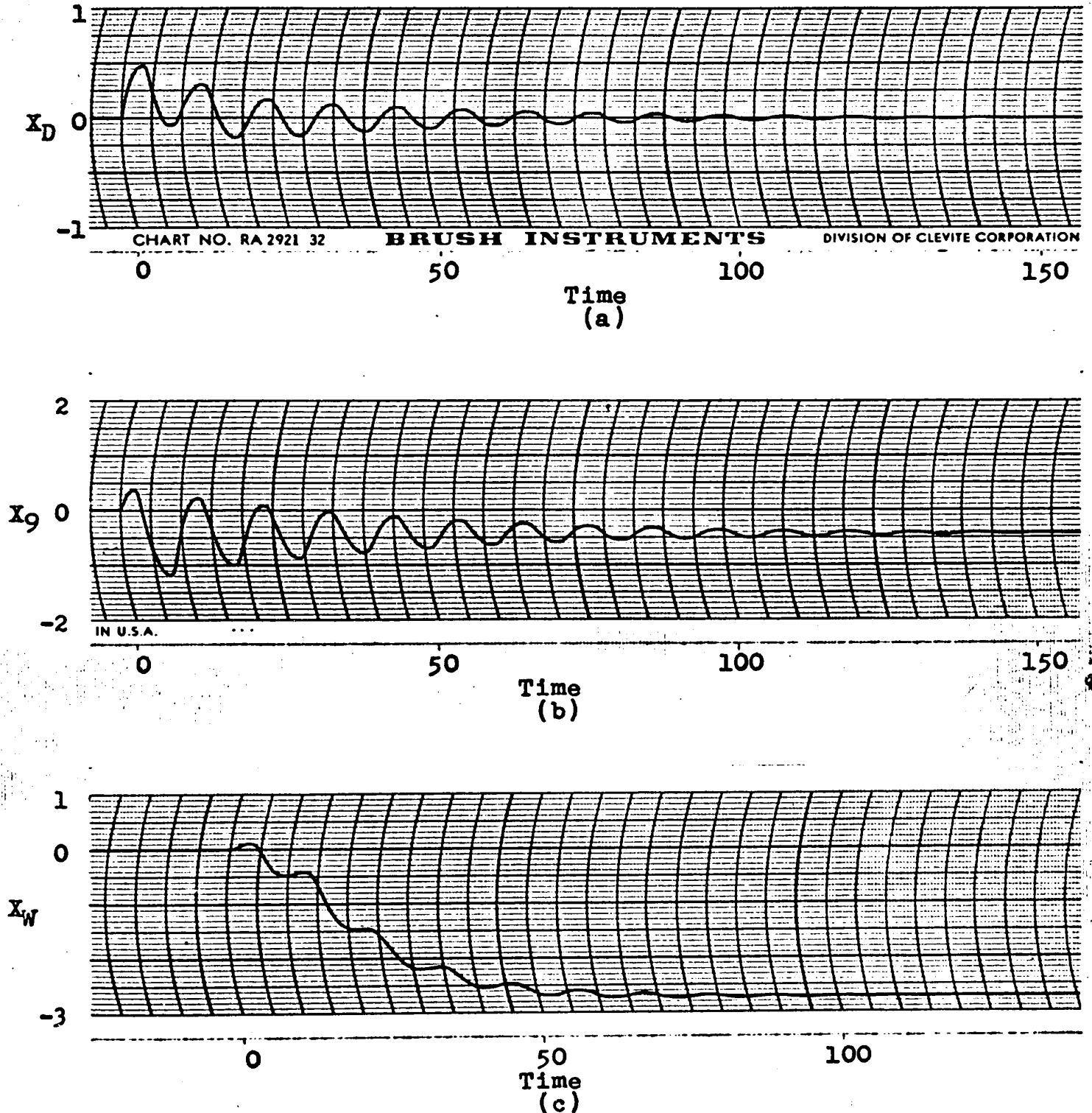
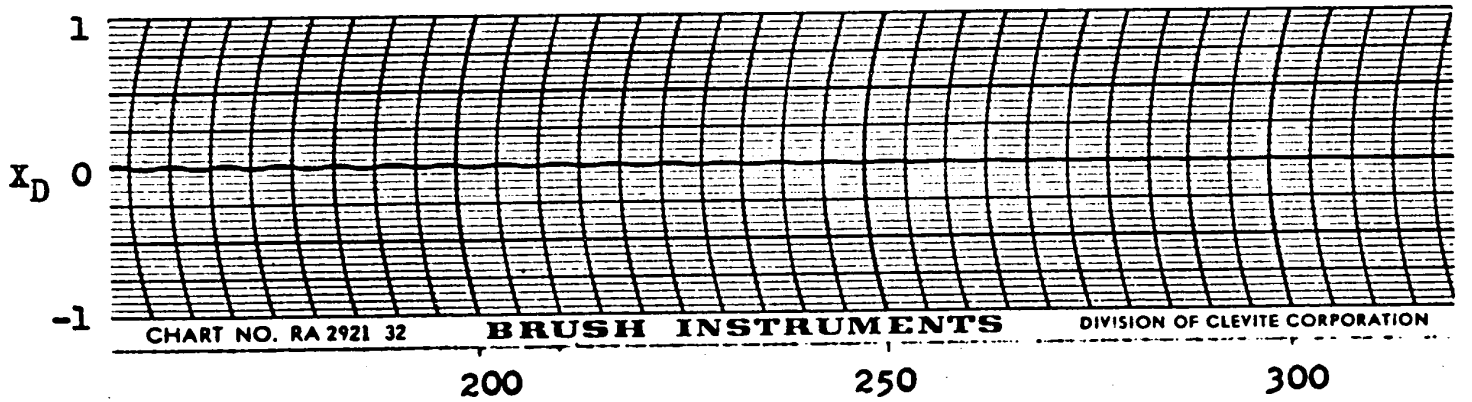
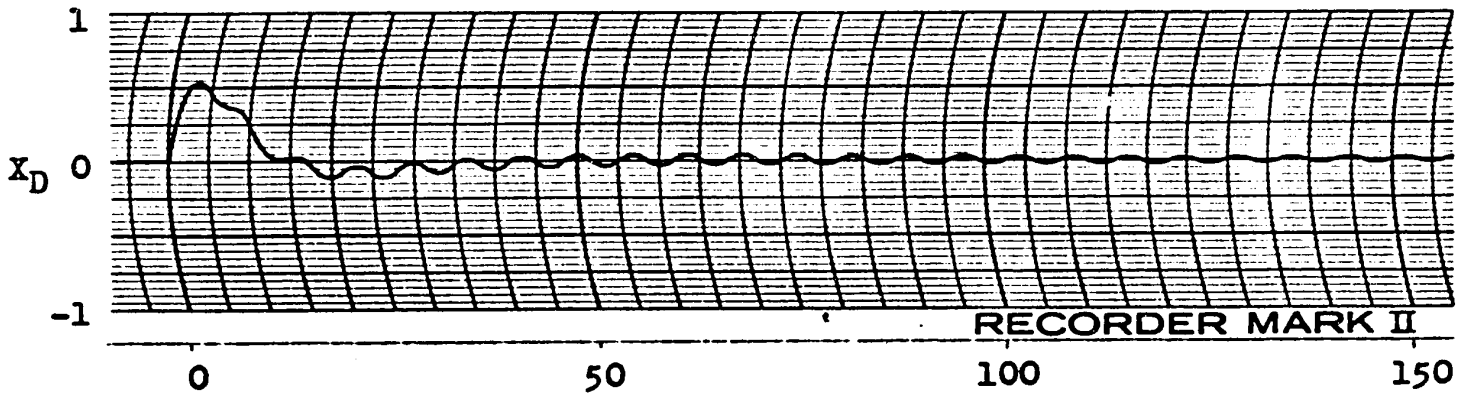
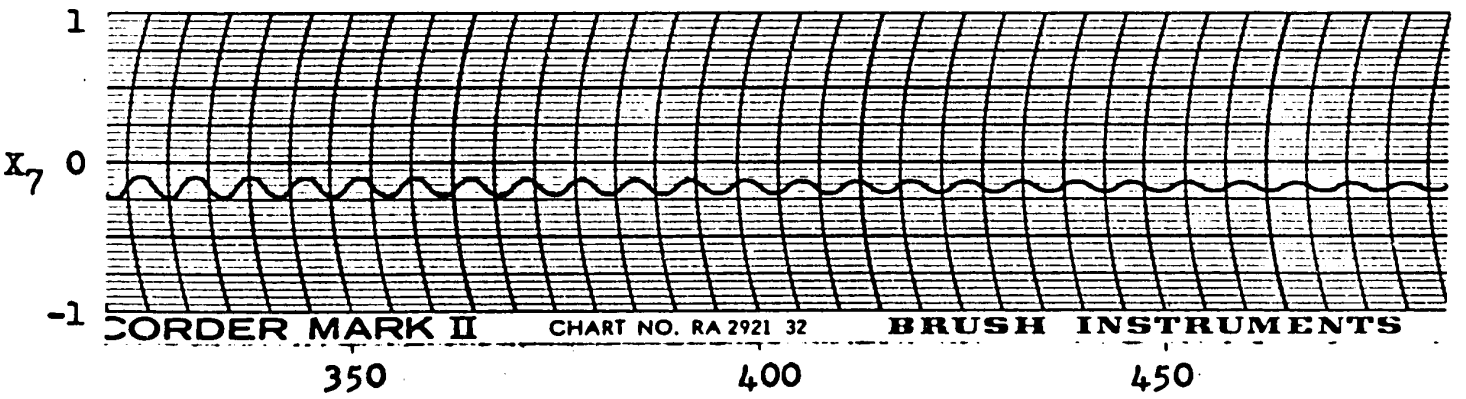
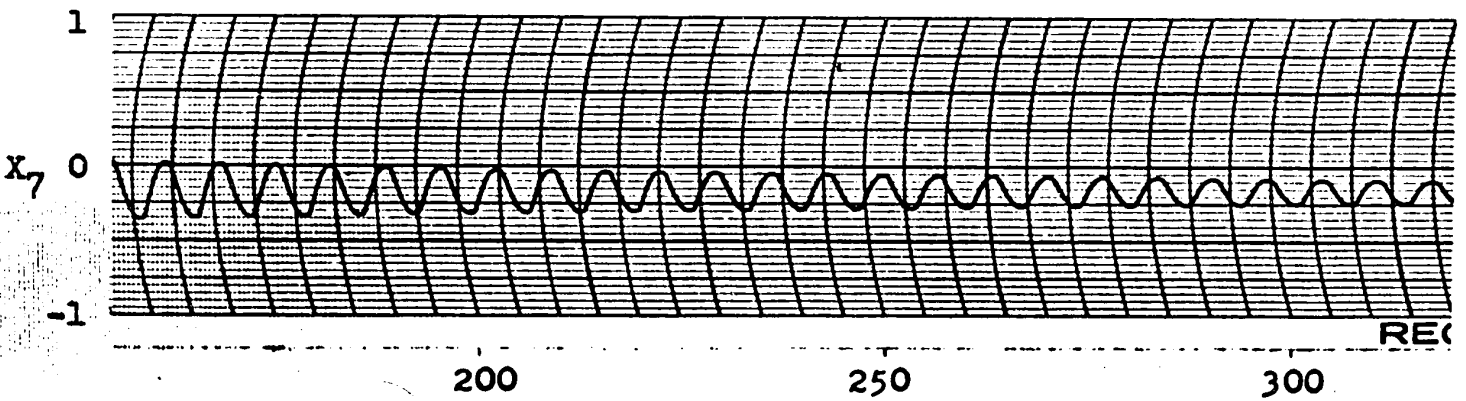
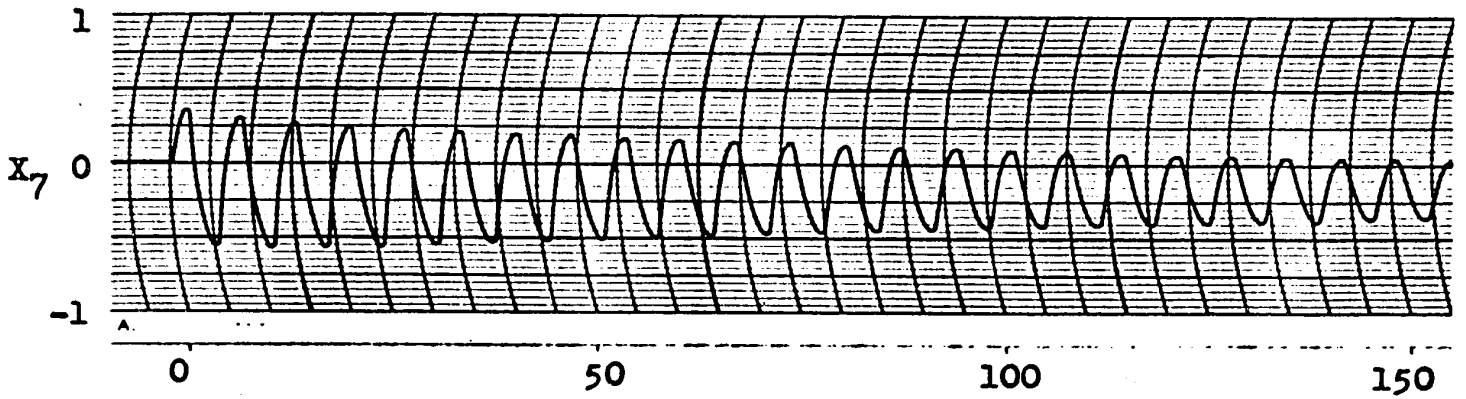

Figure 40. Response of control plate and product compositions when the sensor is on plate 9.



Time
(a)
(Figure 41)



ORDER MARK II CHART NO. RA 2921 32 BRUSH INSTRUMENTS

350

400

450

(Figure 41)

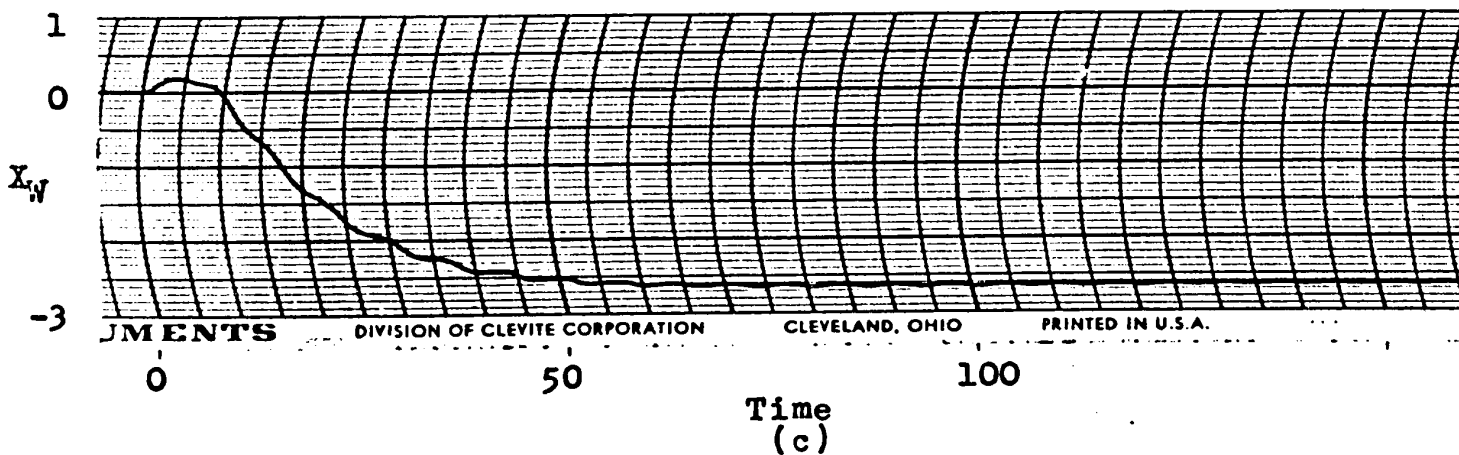
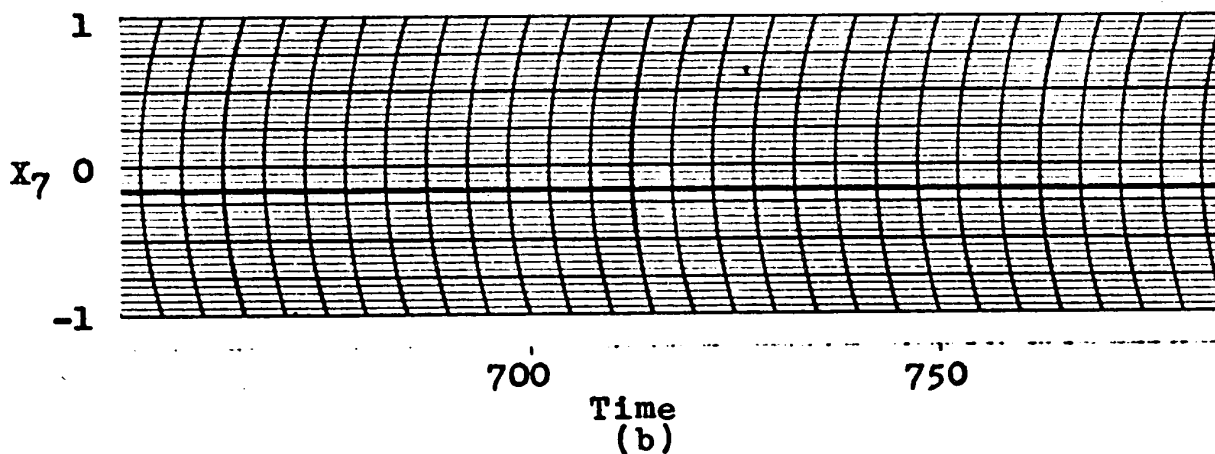
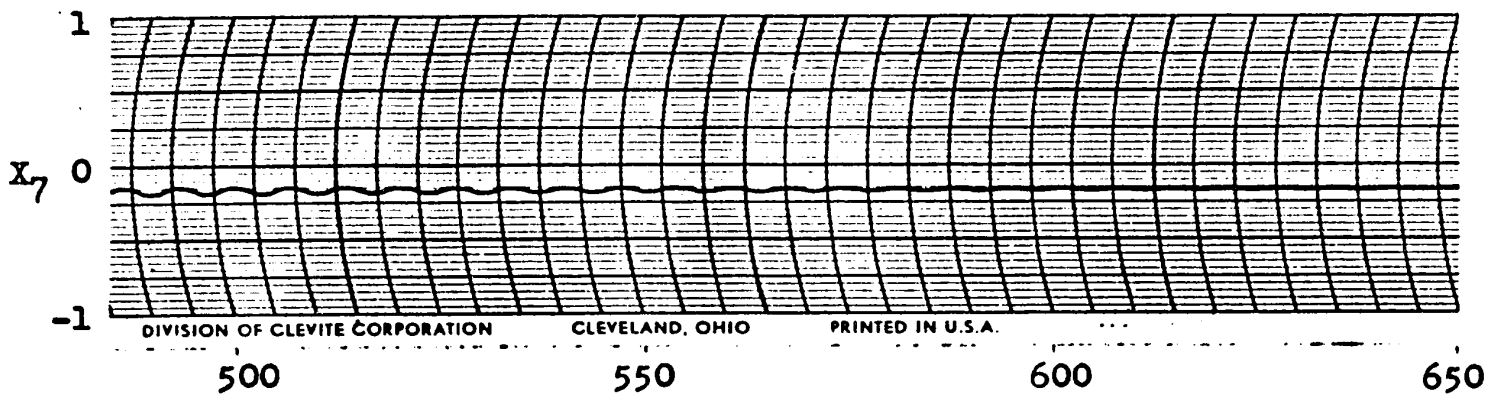

Figure 41. Response of control plate and product compositions when the sensor is on plate 7.

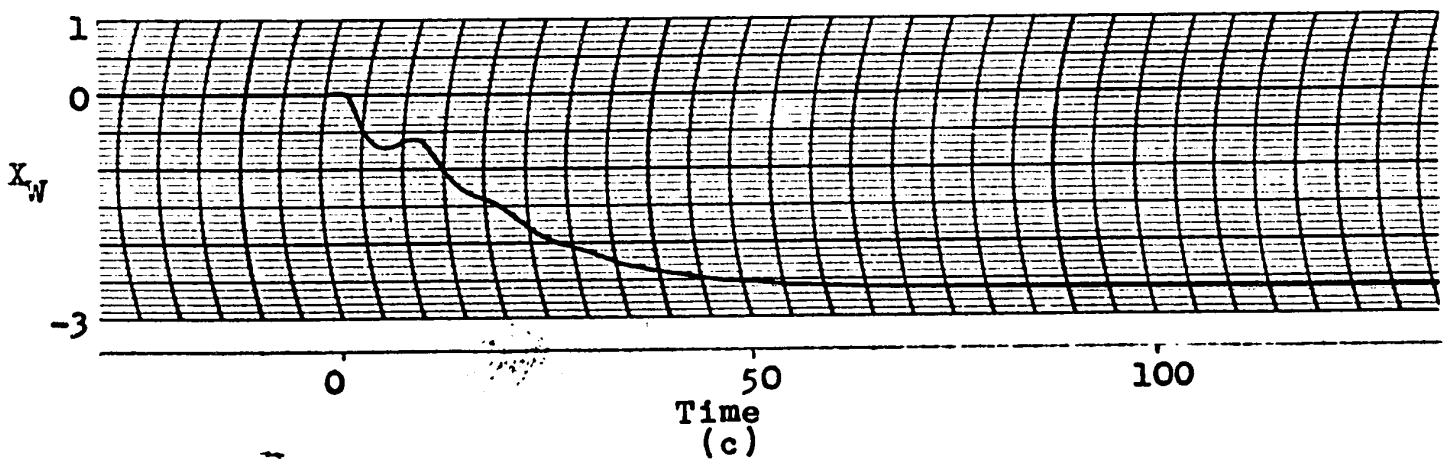
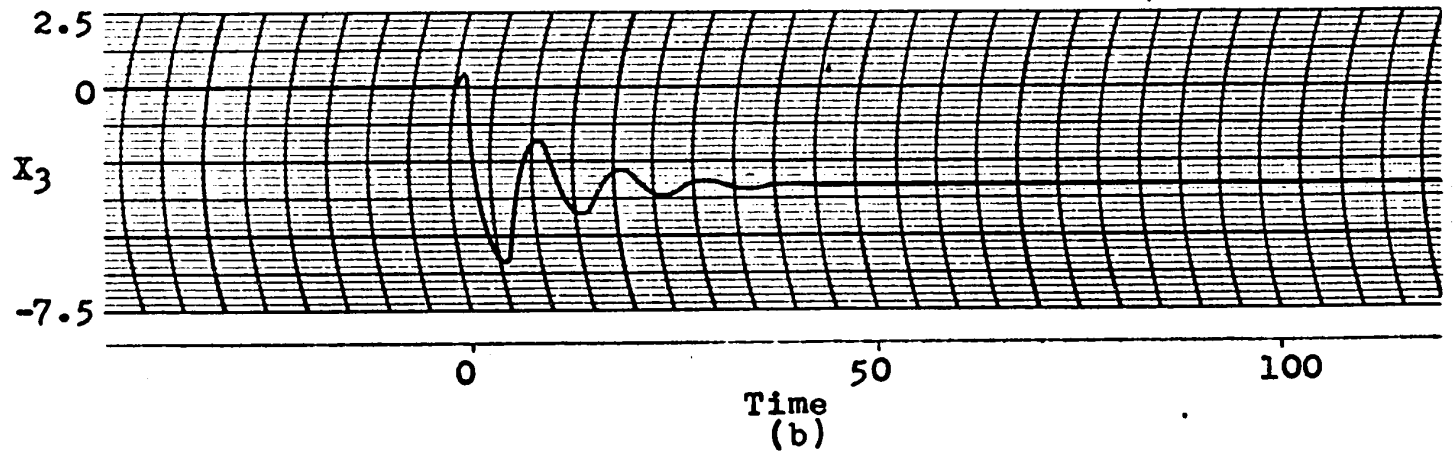
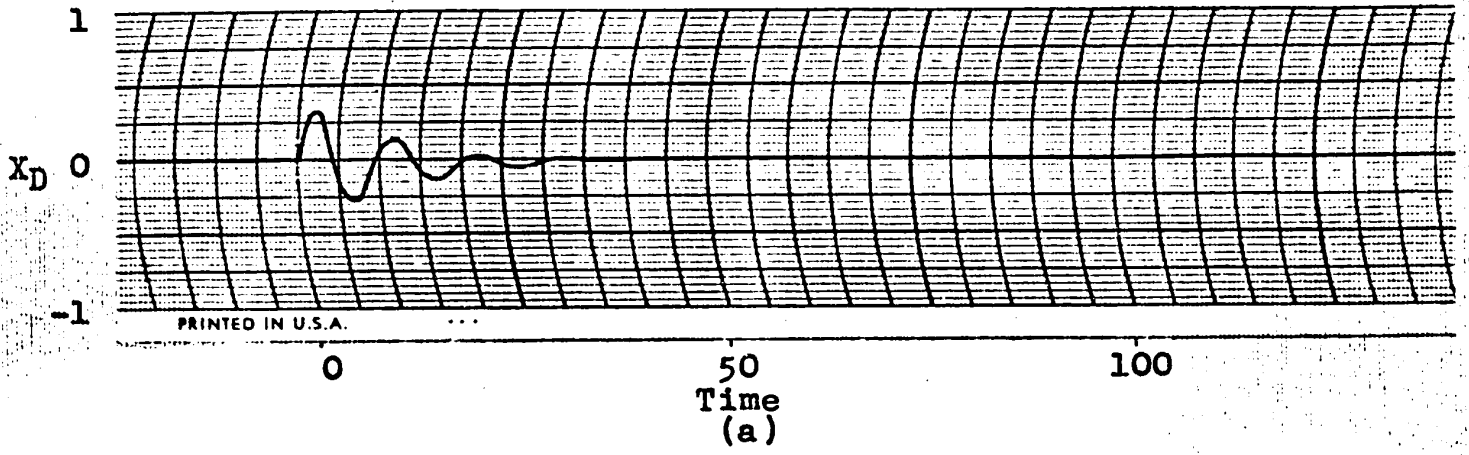

Figure 42. Response of control plate and product compositions when the sensor is on plate 3.

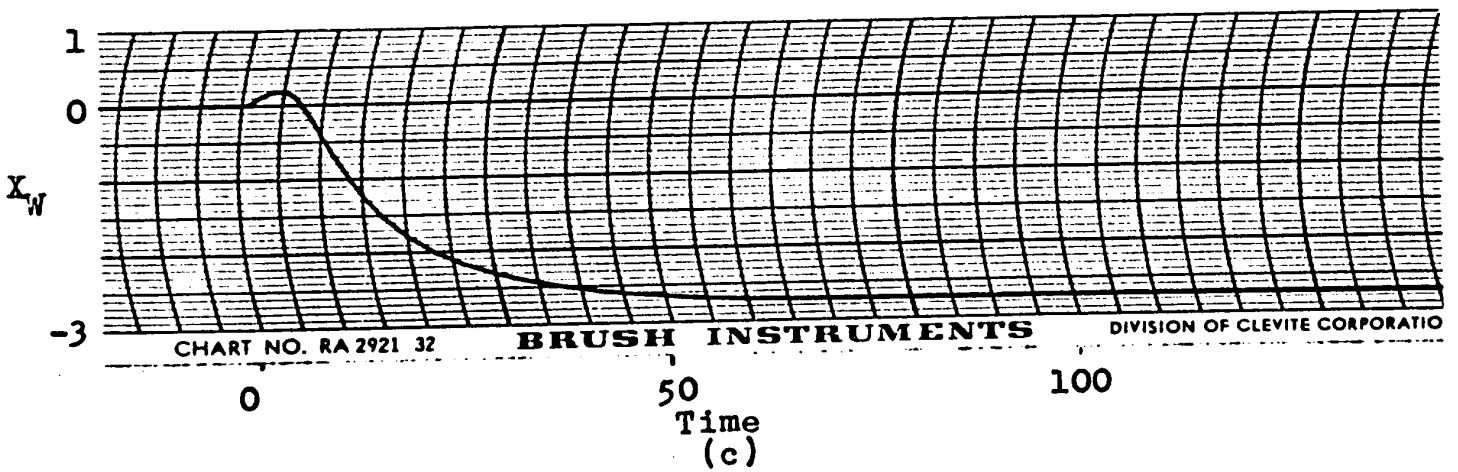
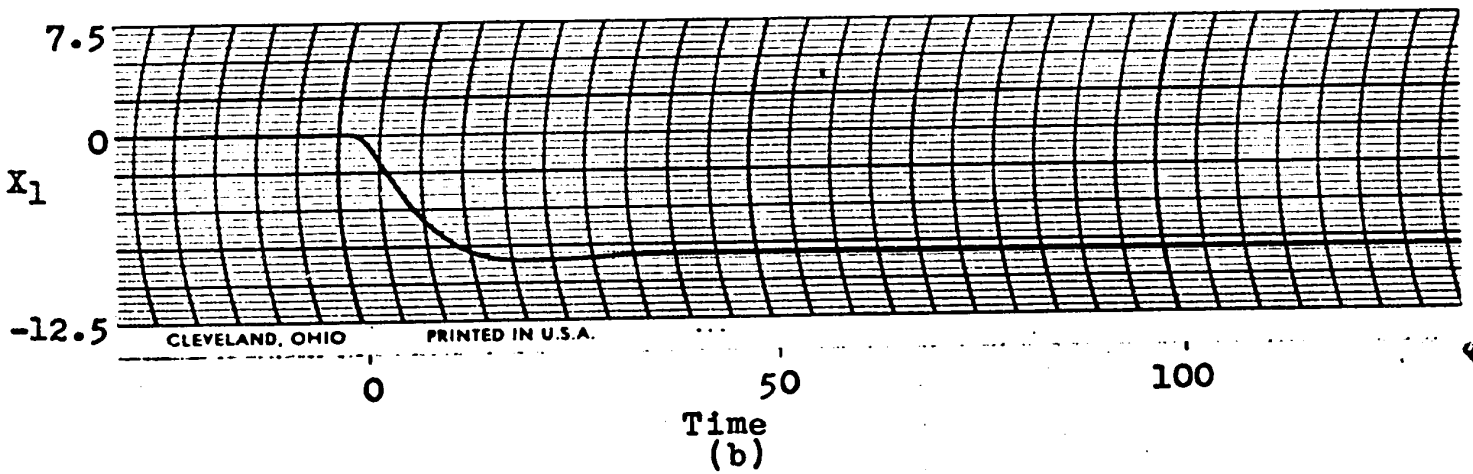
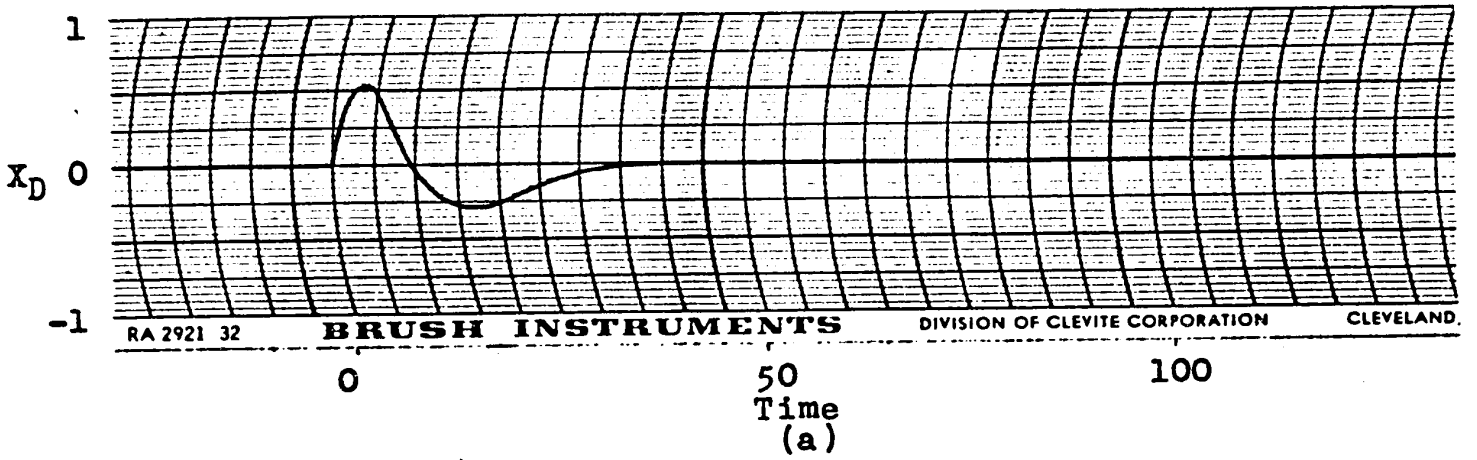

Figure 43. Response of control plate and product compositions when the sensor is on plate 1.

E) Control criterion: minimize $\int_0^{\infty} e^2 dt$ for the bottom product
Manipulative control: reflux rate

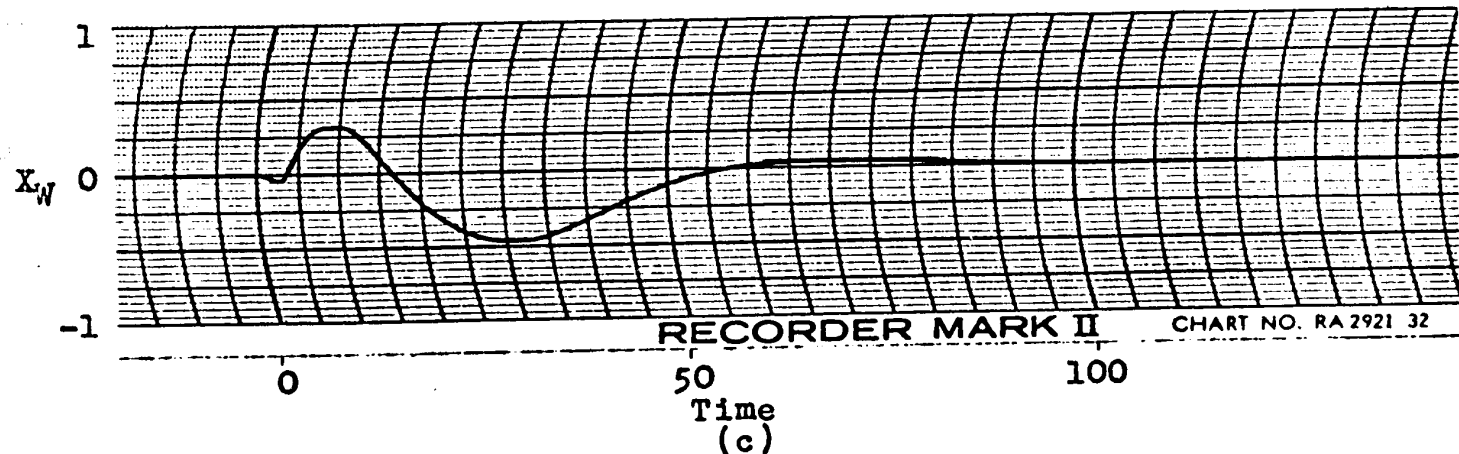
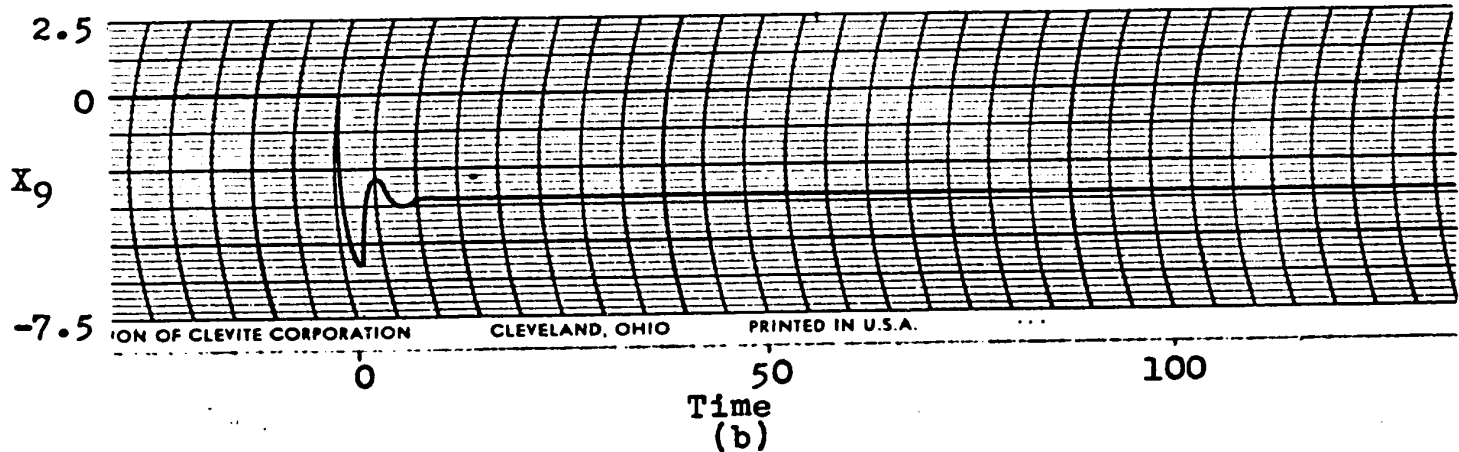
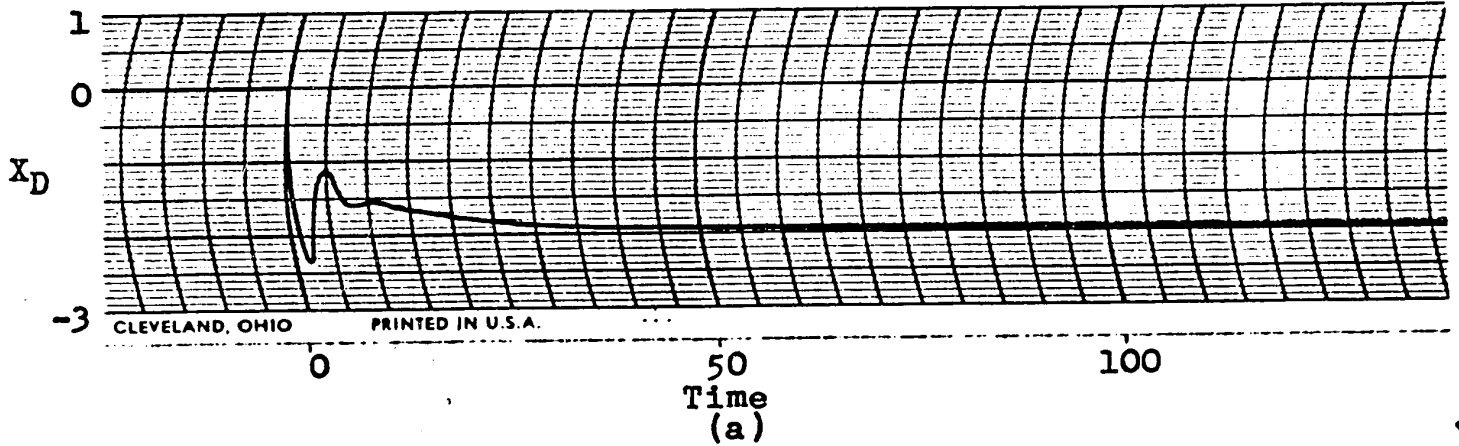

Figure 44. Response of control plate and product compositions when the sensor is on plate 9.

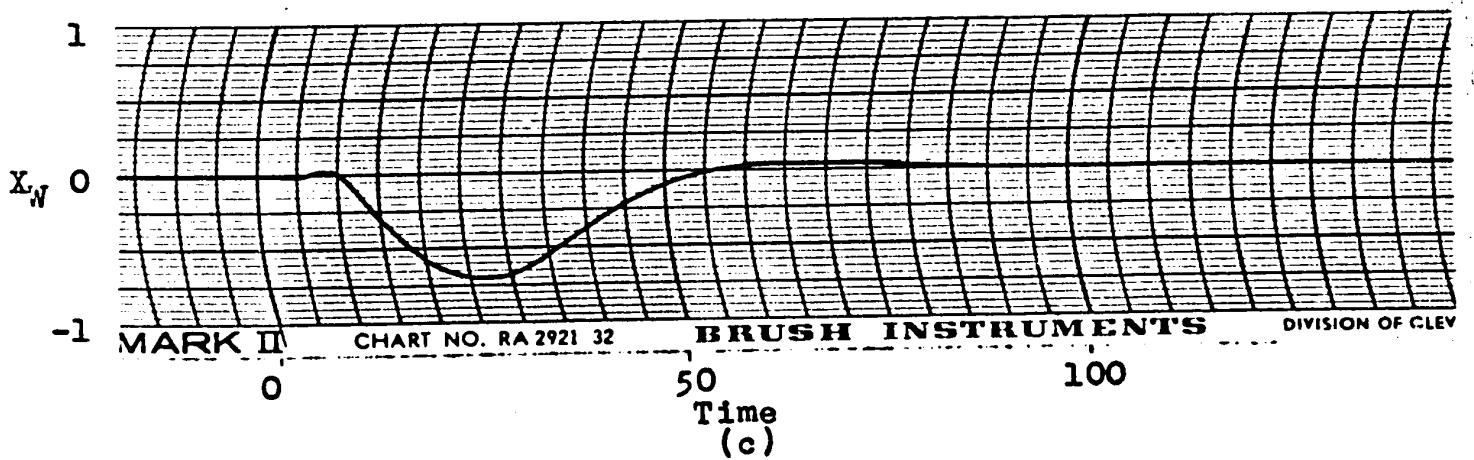
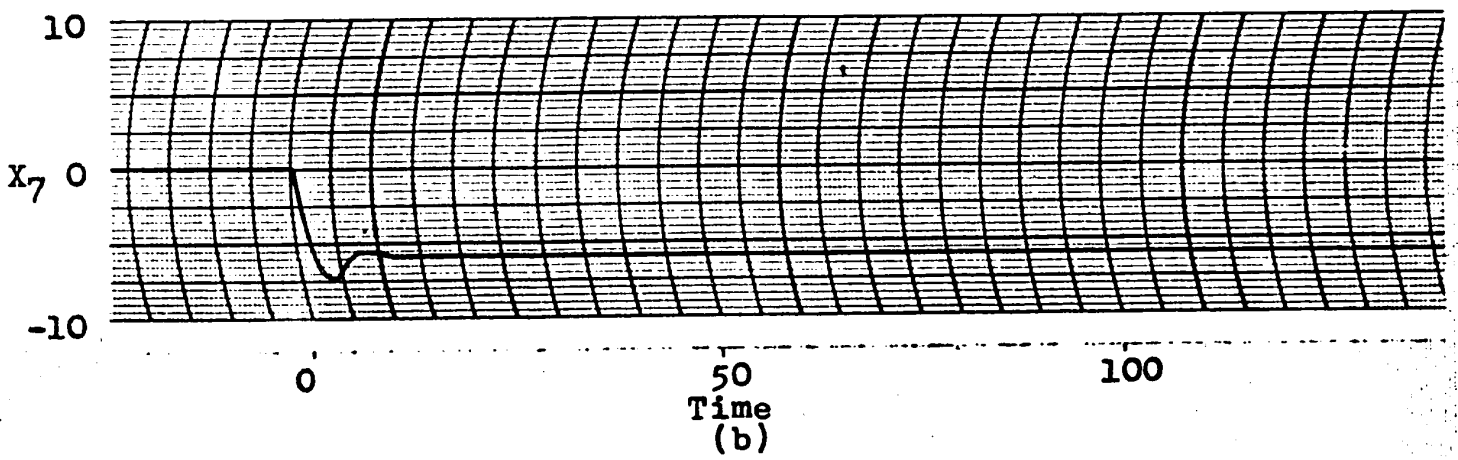
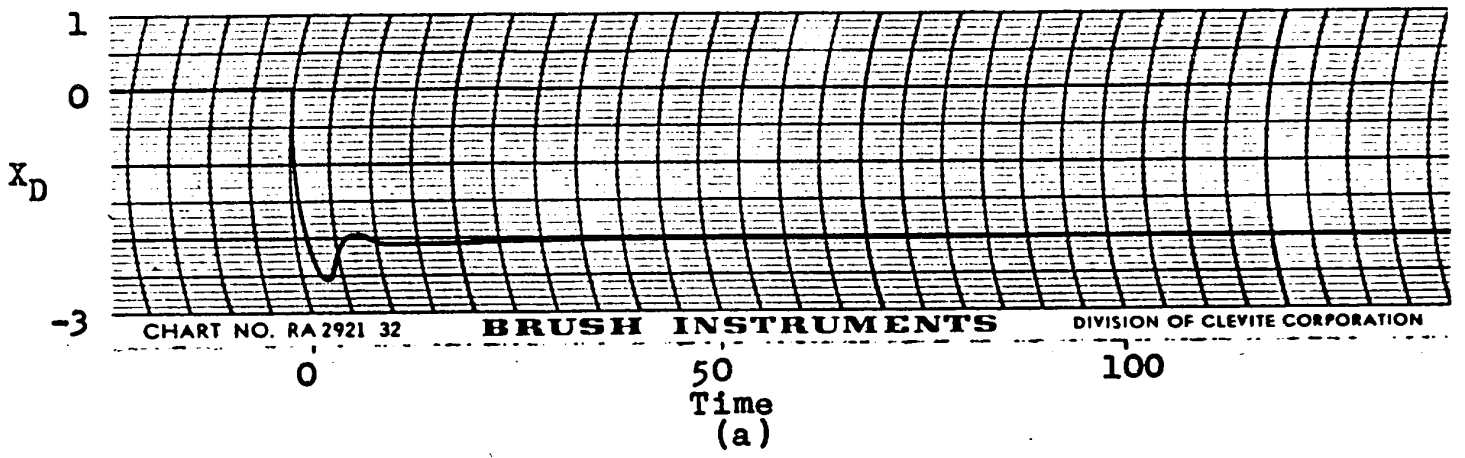

Figure 45. Response of control plate and product compositions when the sensor is on plate 7.

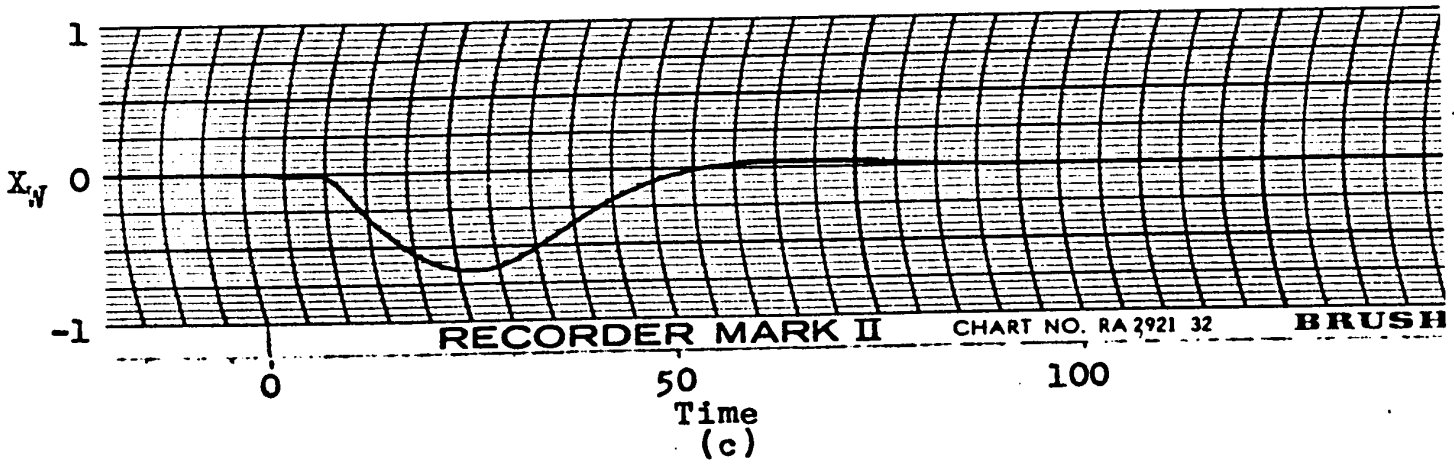
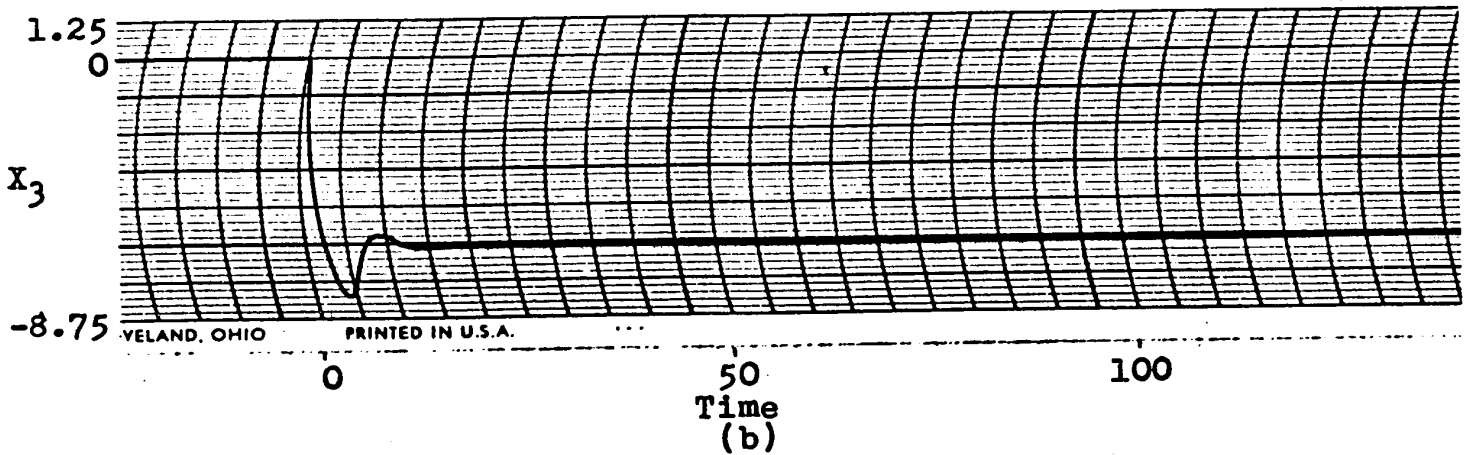
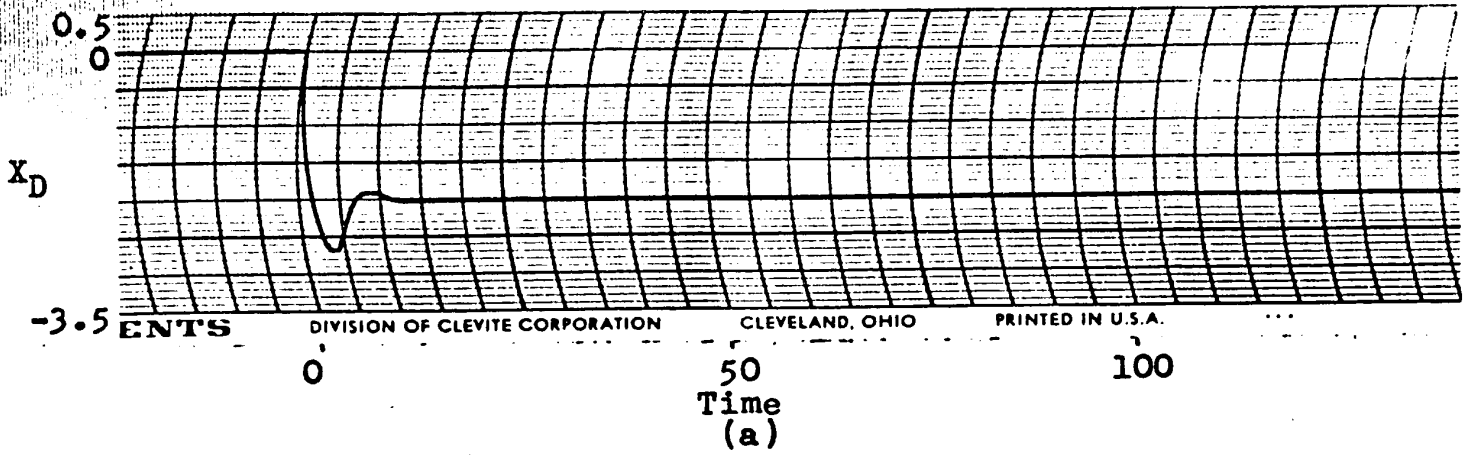

Figure 46. Response of control plate and product compositions when the sensor is on plate 3.

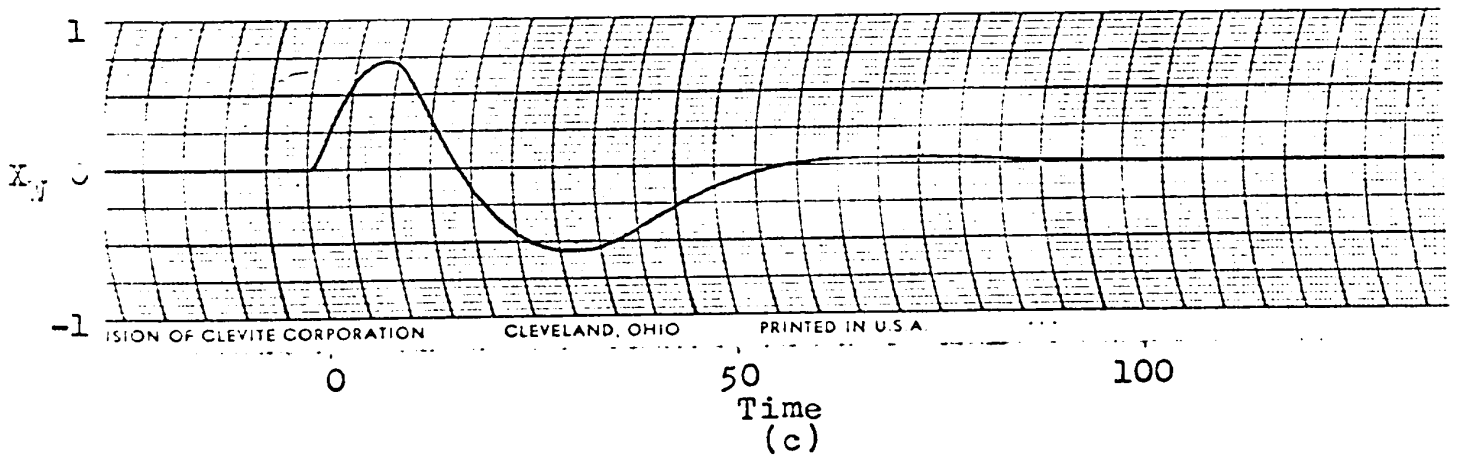
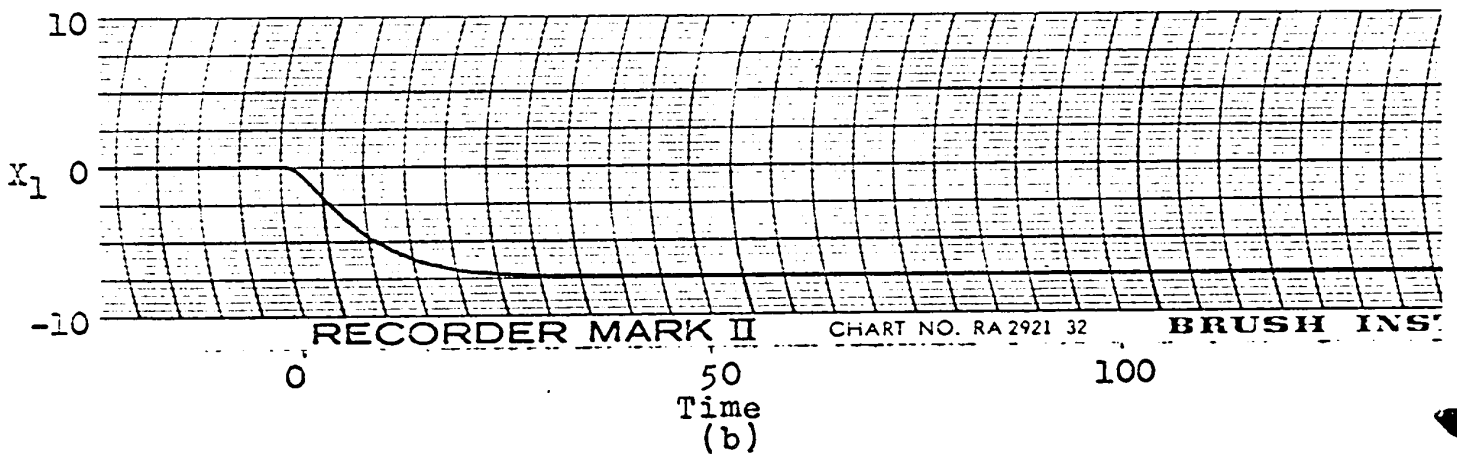
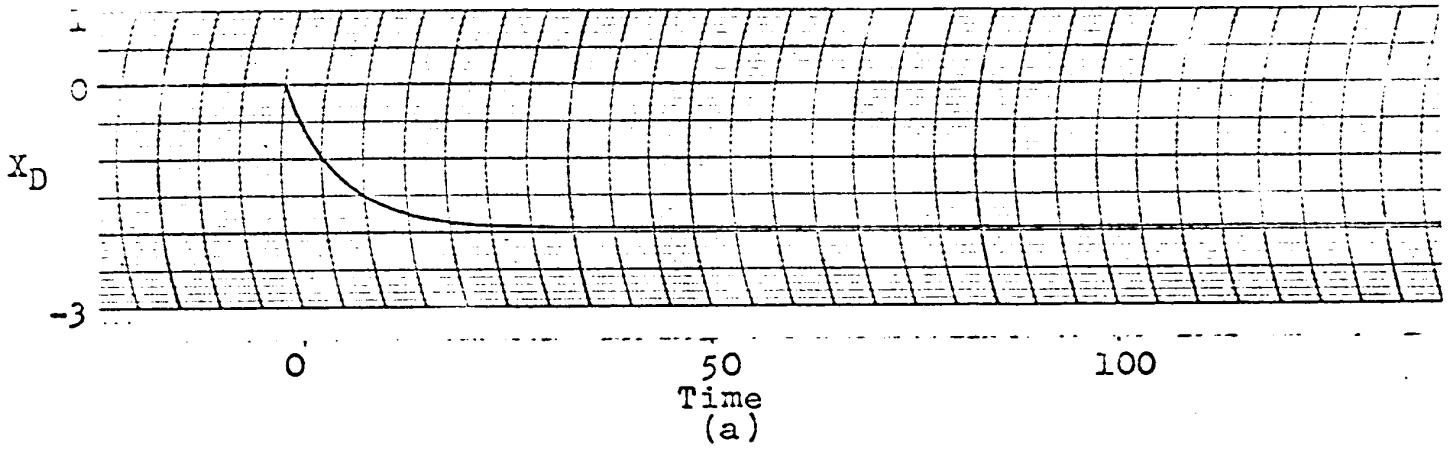

Figure 47. Response of control plate and product compositions when the sensor is on plate 1.

F) Control criterion: minimize $\int_0^{\infty} e^2 dt$ for the bottom product
Manipulative control: reboil vapour rate

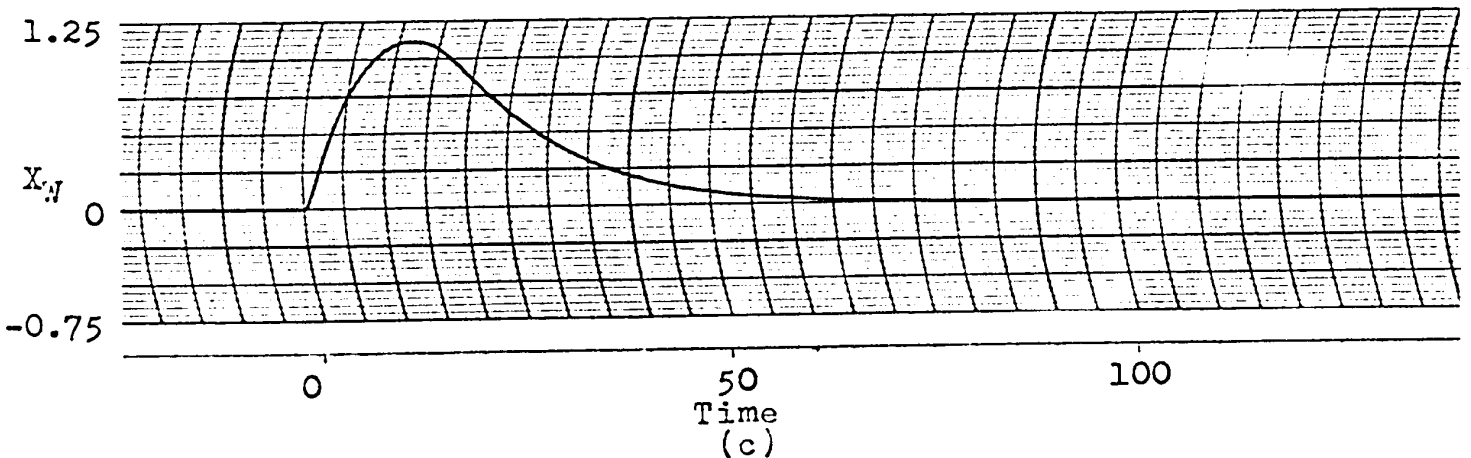
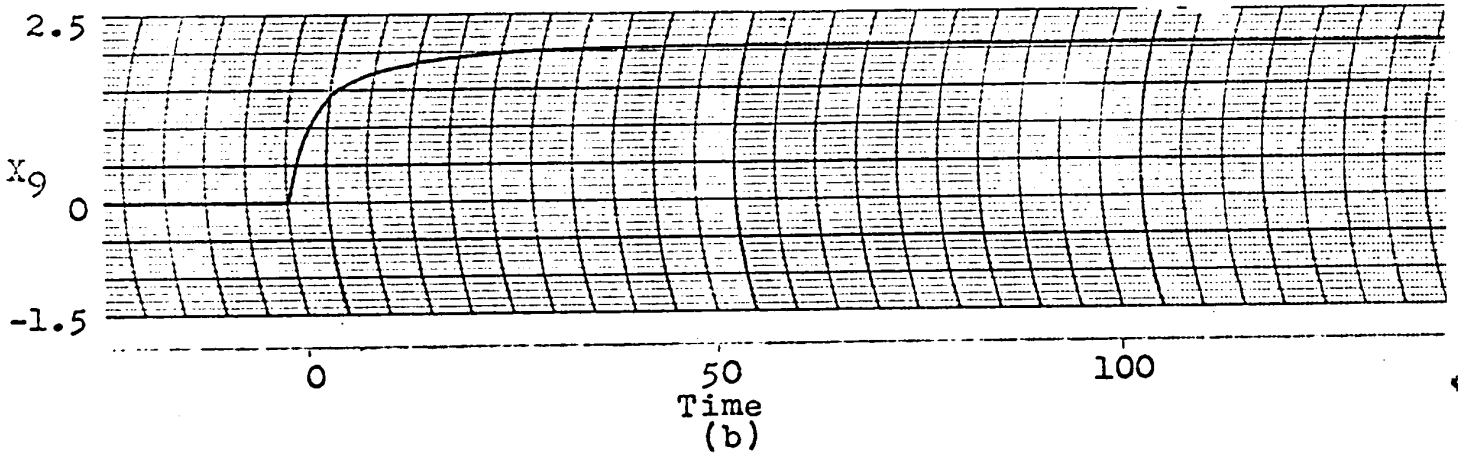
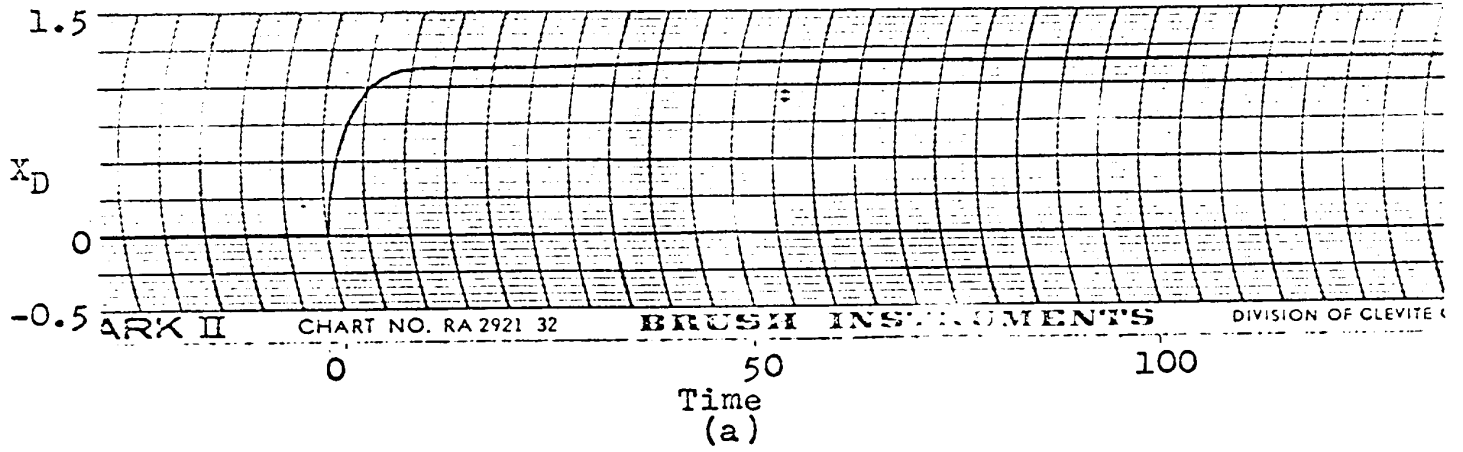

Figure 48. Response of control plate and product compositions when the sensor is on plate 9.

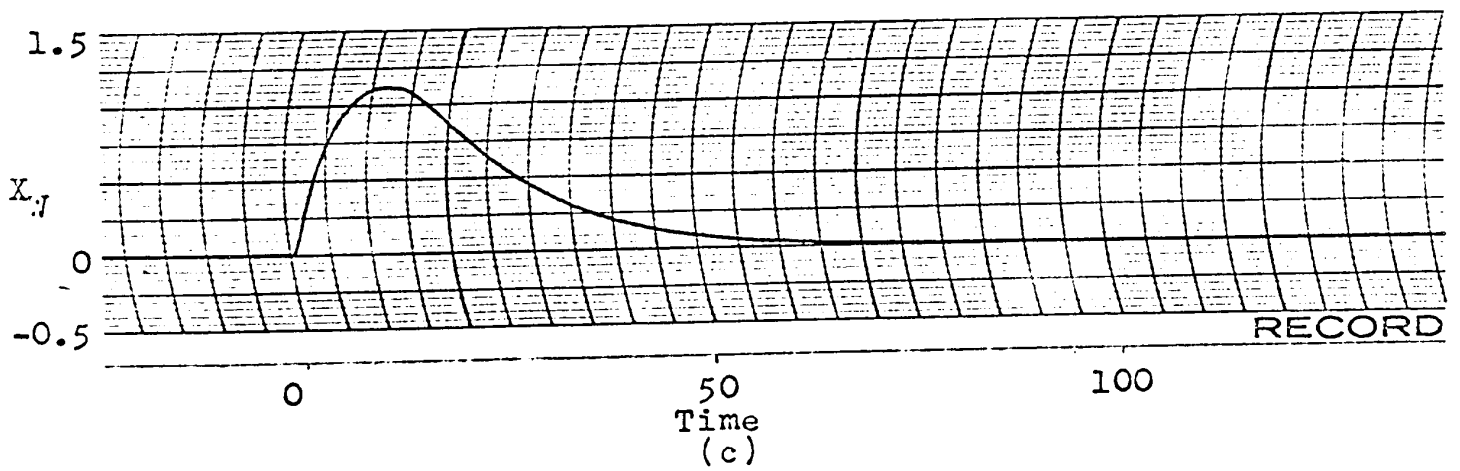
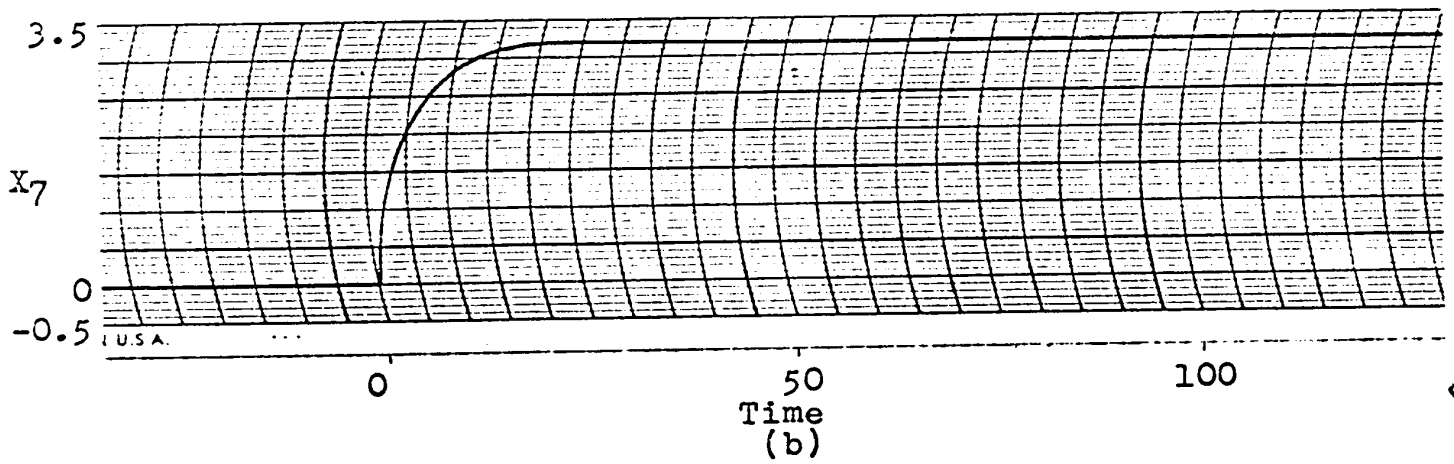
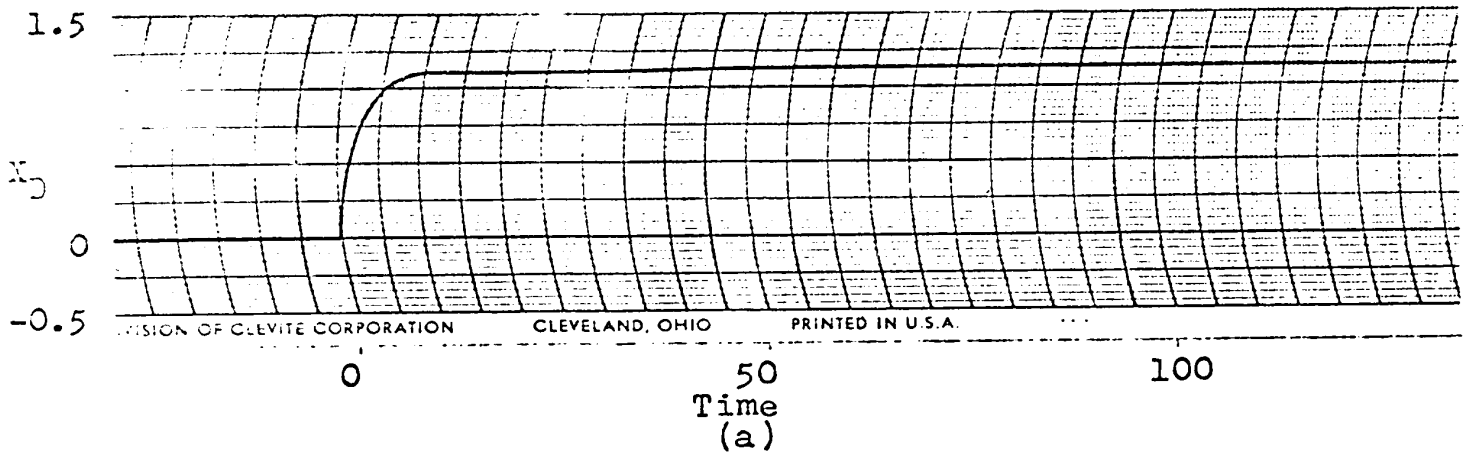

Figure 49. Response of control plate and product compositions when the sensor is on plate 7.

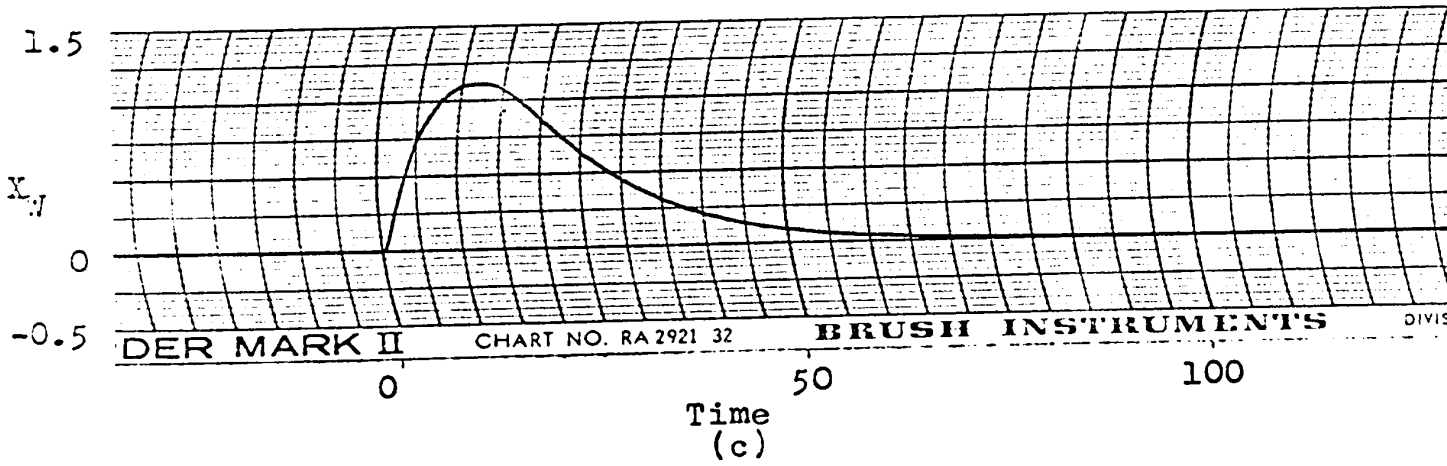
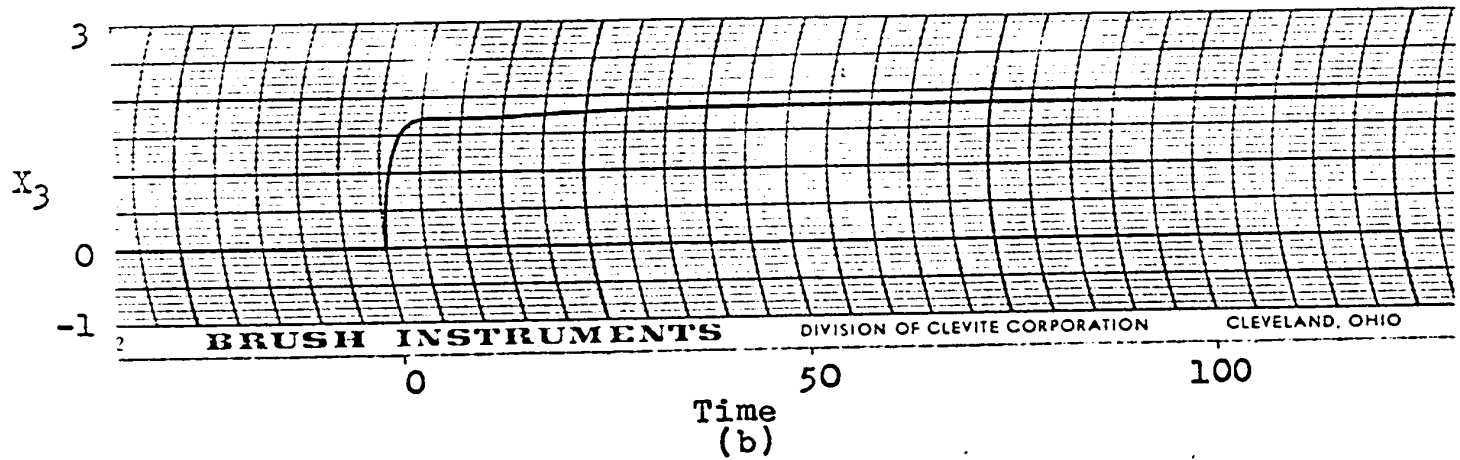
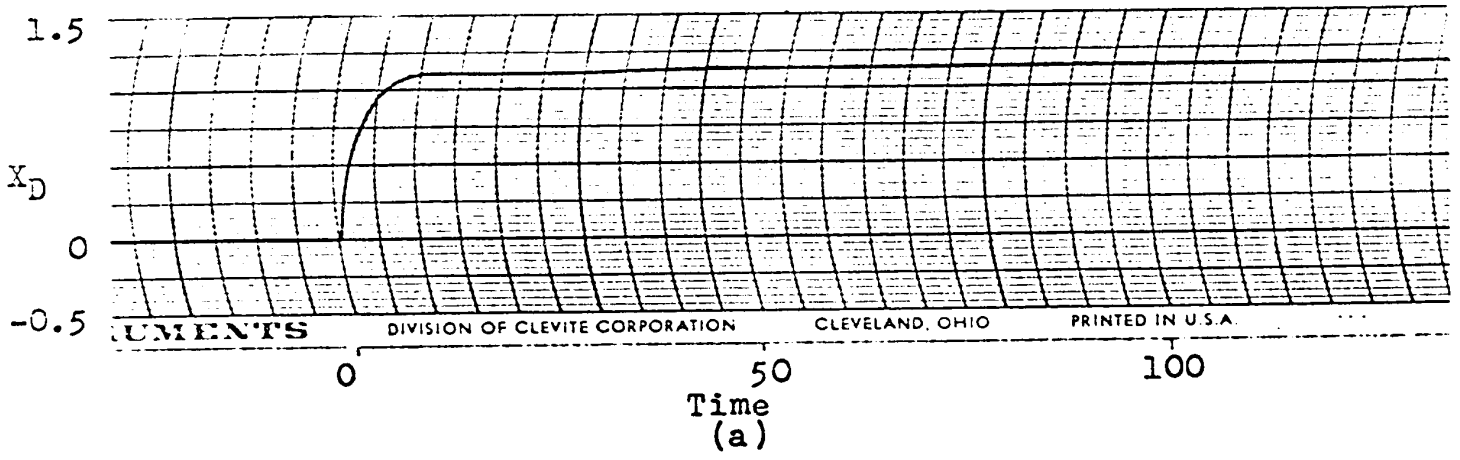

Figure 50. Response of control plate and product compositions when the sensor is on plate 3.

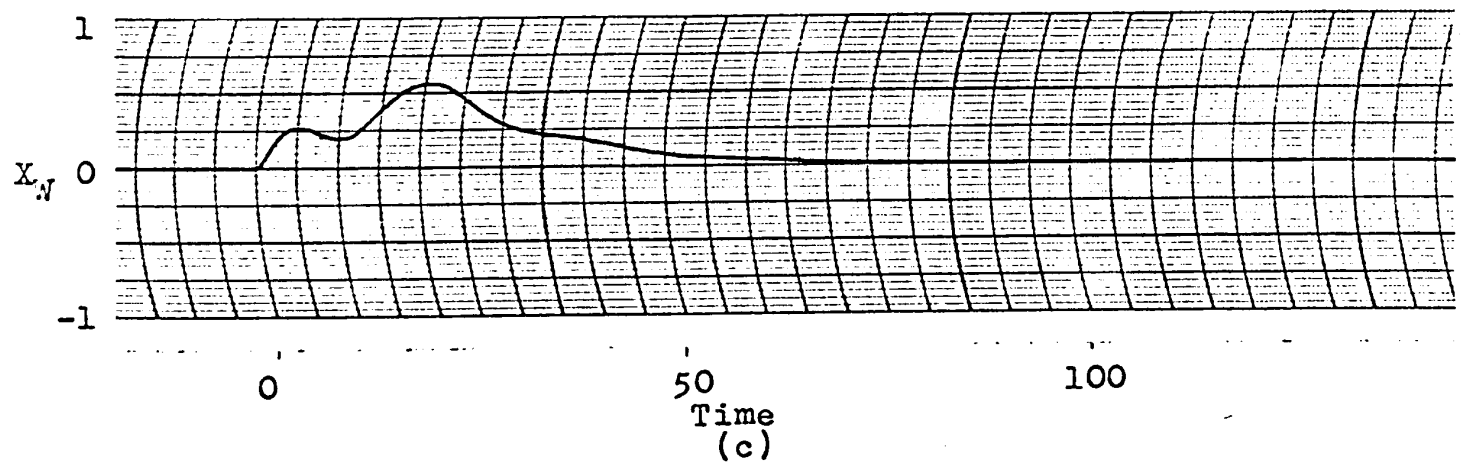
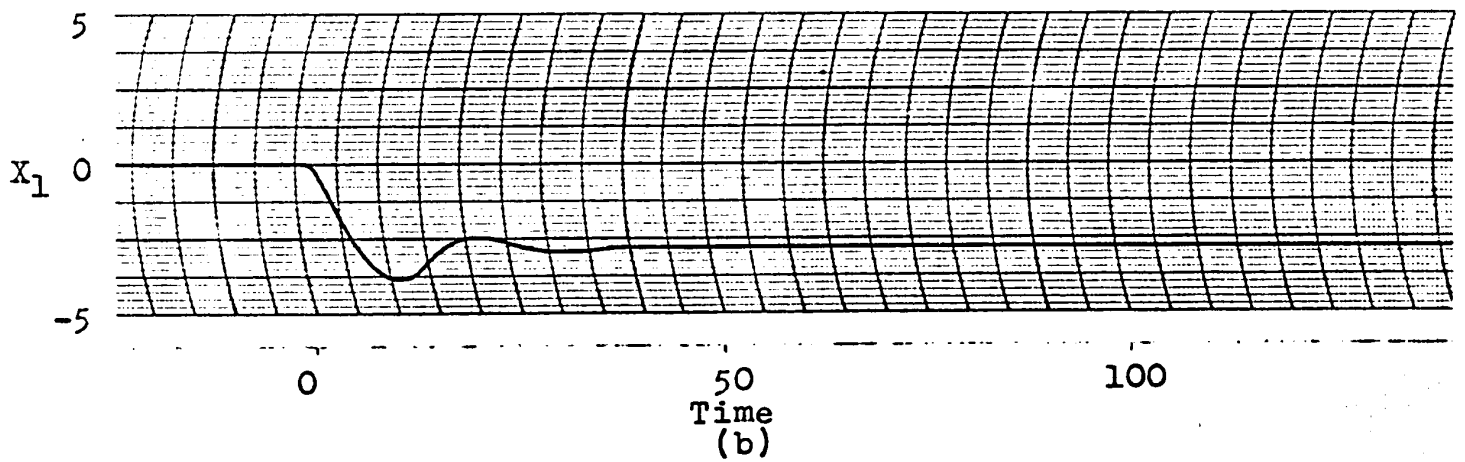
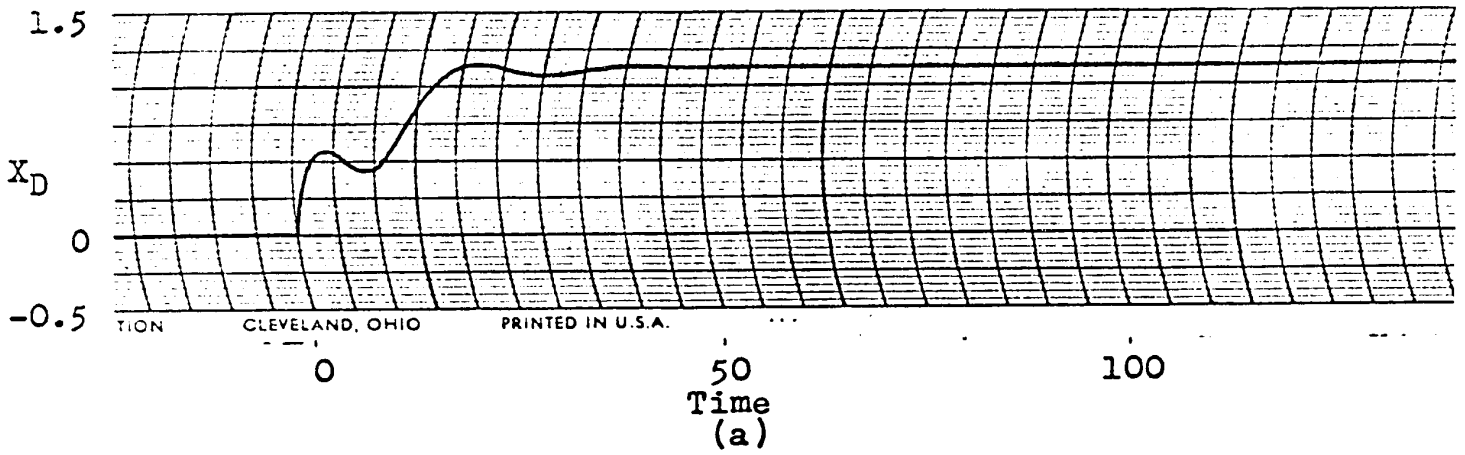

Figure 51. Response of control plate and product compositions when the sensor is on plate 1.

SUMMARY OF RESULTS

The results shown in Figures 12 to 51 inclusive are summarized in Table 1. For the purpose of tabulating the results, the performance of the control schemes was characterized by:

- 1) The maximum deviation of the composition of the liquid on the control plate and of the product streams in mole % acetone from the initial steady state and was denoted by M.D.
- 2) The offset of the composition of the liquid on the control plate and of the product streams from the initial steady state and was denoted by Off.
- 3) The settling time in minutes and was denoted by S.T. The settling time was arbitrarily defined as:
 - a) If $Off = 0$, settling time is the time required for the amplitude of oscillation to remain less than $\pm 10\%$ of the maximum deviation.
 - b) If $Off \neq 0$, settling time is the time required for oscillations to remain within $\pm 10\%$ of the final offset.

Table 1
Summary of Results

Feedback control Instantaneous feedforward plus feedback control
 No composition off- No composition off- No composition No composition
 set where sensor set where sensor effect in top effect in bot-
 is located. is located product. tom product.

Sensor
Location

Reflux Reboil Reflux Reboil Reflux Reboil Reflux Reboil Reflux Reboil

Top
Product

Top
M.D. 0.15 1.0 0.01 0.60
 Off. 0.0 0.0 0.0 0.0
 S.T. 15 55 10 34

Top
Product

Top
M.D. 1.83 -2.63 1.83 -2.62
 Off. 1.63 -2.62 1.63 -2.62
 S.T. 45 55 45 37

Plate 9

Top
M.D. 0.36 1.09 0.25 0.66 0.035 0.47 -2.39 1.16
 Off. -0.14 0.155 -0.14 0.155 0.0 0.0 -1.95 1.16
 S.T. 55 60 55 23 55 93 20 7

Top
M.D. 0.41 1.7 -0.22 0.73 -0.41 -1.18 -5.8 2.09
 Off. 0.0 0.0 0.0 0.0 0.28 -0.42 -3.5 2.09
 S.T. 32 50 15 20 60 125 7 15

Top
M.D. 1.66 -2.27 1.60 -2.27 1.63 -2.71 -0.47 1.11
 Off. 1.52 -2.27 1.52 -2.27 1.63 -2.71 0.0 0.0
 S.T. 46 46 45 44 50 46 54 46

Feedback control Instantaneous feedforward plus feedback control

Sensor location

No composition off-set where sensor is located No composition off-set where sensor is located

Reflux Reboil Reflux Reboil Reflux Reboil Reflux Reboil Reflux Reboil

**X₁
M.D.
Off.
S.T.**

0.33	0.905	-0.06	0.62	0.035	0.53	-2.59	1.14
0.044	0.65	0.044	0.05	0.0	0.0	-2.02	1.14
78	45	50	45	38	38	5	12

**X₇
M.D.
Off.
S.T.**

0.95	1.9	0.12	0.57	0.32	-0.56	-7.45	3.19
0.0	0.0	0.0	0.0	0.115	-0.16	-5.95	3.19
44	50	27	23	30	515	5	11

Plate 7

**X₅
M.D.
Off.
S.T.**

1.67	-2.50	1.70	-2.50	1.67	-2.63	-0.70	1.12
1.67	-2.50	1.67	-2.50	1.64	-2.63	0.0	0.0
45	43	45	38	48	39	51	55

**X₁
M.D.
Off.
S.T.**

0.30	1.05	-0.27	0.76	0.029	0.33	-2.70	1.14
0.07	0.73	-0.07	0.73	0.0	0.0	-2.01	1.14
55	18	40	4	23	30	7	6

**X₃
M.D.
Off.
S.T.**

1.37	2.50	0.46	1.21	0.65	-5.85	-8.1	1.84
0.0	0.0	0.0	0.0	0.225	-3.3	-6.35	1.84
25	27	19	16	20	23	11	5

Plate 3

**X₁
M.D.
Off.
S.T.**

1.60	-0.95	1.60	-0.95	1.68	-2.63	-0.66	1.11
1.57	-0.95	1.57	-0.95	1.66	-2.63	0.0	0.0
45	58	45	50	45	38	51	57

Feedback control Instantaneous feedforward plus feedback control

Sensor location

No composition off-set where sensor is located. No composition effect where sensor is located. No composition effect in top product. No composition effect in bottom product.

Reflux Reboil Reflux Reboil Reflux Reboil Reflux Reboil

**I₁:
M.D.
Off.
S.T.**

1.0 1.82 1.0 1.74 -0.01 0.54 -1.95 1.15
0.80 1.72 0.80 1.72 0.0 0.0 -1.95 1.13
28 16 28 15 60 31 15 17

**I₂:
M.D.
Off.
S.T.**

0.20 1.37 -0.36 0.27 -2.21 -6.5 -7.5 -3.93
0.0 0.0 0.0 0.0 -2.20 -6.2 -7.5 -2.79
55 71 18 78 17 13 17 22

**I₃:
M.D.
Off.
S.T.**

2.31 1.95 2.31 1.76 1.63 -2.73 0.73 0.56
2.30 1.33 2.30 1.33 1.63 -2.73 0.0 0.0
11 55 12 40 45 38 54 55

**I₄:
M.D.
Off.
S.T.**

-3.96 1.56 -3.65 1.28 - - - -
-1.97 1.14 -1.97 1.14 - - - -
175 83 122 44

Bottom Product

**I₅:
M.D.
Off.
S.T.**

1.25 1.28 -0.71 0.66 - - - -
0.0 0.0 0.0 0.0 - - - -
157 87 86 62

ANALYSIS OF RESULTS

In the analysis of results only the maximum deviation and the offset in the product compositions were considered in making recommendations. Low offset was considered more important than low maximum deviation in cases of conflict.

1) Table 2 indicates the more desirable manipulative variable for each of the control schemes when the objective was to minimize the deviation in the top product composition from its initial steady state value.

Table 3 indicates the more desirable manipulative variable for each of the control schemes when the objective was to minimize the deviation in the bottom product composition from its initial steady state value.

From tables 2 and 3 the following recommendations could be made:

- a) If the main objective is to control the top product composition, reflux rate manipulation should be used to effect control.
- b) If the main objective is to control the bottom product composition, reflux rate manipulation should be used if the sensor is located above the feed plate and reboil vapour rate manipulation should be used if the sensor is located below the feed plate.

Table 2
Recommended manipulative variables
for top product composition control

Sensor location	Feedback control	Inst. FF-FB control	Inst. FF-FB control (X_D 0)
Top product	Reflux	Reflux	-
Plate 9	Reflux	Reflux	Reflux
Plate 7	Reflux	Reflux	Reflux
Plate 3	Reflux	Reflux	Reflux
Plate 1	Reflux	Reflux	Reflux
Bottom product	Reboil	Reboil	-

Table 3
Recommended manipulative variables for
bottom product composition control

Sensor location	Feedback control	Inst. FF-FB control	Inst. FF-FB control (X_W 0)
Top product	Reflux	Reflux	-
Plate 9	Reflux	Reflux	Reflux
Plate 7	Reflux	Reflux	Reflux
Plate 3	Reboil	Reboil	Reflux
Plate 1	Reboil	Reboil	Reboil
Bottom product	Reflux	Reboil	-

- 2) Table 4 shows the optimum sensor locations for the various control schemes when close control of either top or bottom product composition is the main objective. Here it was considered that the sensor was not to be placed in the product streams because of the relatively more difficult task of determining compositions accurately and quickly at high purities.
- 3) Table 5 shows the best combination of manipulative variable and sensor location to achieve closest control of product compositions for the control schemes that were investigated.

Table 4
Optimum sensor locations for
product composition control

Control scheme	Manipulative variable	Top product	Bottom product
Feedback	Reflux	7	9
Feedback	Reboil	7	3
FF-FB	Reflux	7	9
FF-FB	Reboil	7	3
FF-FB ($X_D=0$)	Reflux	1	-
FF-FB ($X_D=0$)	Reboil	3	-
FF-FB ($X_W=0$)	Reflux	-	9
FF-FB ($X_W=0$)	Reboil	-	1

Table 5
Optimum control configurations
for product composition control

Control scheme	Manipulative variable	Product controlled	Sensor location
Feedback	Reflux	Top	7
Feedback	Reboil	Bottom	3
FF-FB	Reflux	Top	7
FF-FB	Reboil	Bottom	3
FF-FB ($X_D=0$)	Reflux	Top	1
FF-FB ($X_W=0$)	Reflux	Bottom	9

DISCUSSION OF RESULTS

- 1) Bauer and Orr (6), using the McCabe-Thiele diagram approach, pointed out that an offset in the top and bottom product composition is inevitable for control schemes which maintain a constant composition on an intermediate plate. The results of this study substantiate this conclusion. It is interesting to note that with control schemes 2-g to 2-j this disadvantage of placing the sensor on an intermediate plate can be overcome.
- 2) Anisimov (1) recommends that the sensing element should be placed on the plate where the concentration gradient is a maximum. He suggests that distillation column control through the detection of composition of top or bottom product streams is impossible because the static and dynamic characteristics of the process would deteriorate substantially. In the discussion of this article, P.S. Buckley and T.J. Williams disagree with this position. They point out that on the basis of their experience product streams are among the best locations for the sensing element. This work supports the stand taken by Buckley and Williams.
- 3) Forman (9, 10), writing a refresher article on automatic control, recommends without reservation the control policy advanced by Anisimov (1) and makes no mention of the serious criticisms advanced by P.S. Buckley, T.J. Williams, and

D.E. Lamb in their discussion of Anisimov's paper.

- 4) Inasa and Morinaga (18) and Williams et al (24, 33, 34, 35) recommend that for feedback control of top product composition by reflux rate manipulation, the sensor should be placed on the top plate. Their arguments are based on frequency response theory, arguing that the longer hydraulic lag to a lower plate reduces the range of control parameters suitable for stable operation. Though it was found that the range of the gain K , suitable for stable control, does indeed decrease for lower plates, close control of top product composition was still possible when the sensor was placed on a lower plate.
- 5) Duckley (8) recommends that for feedback control of the top product composition the sensor should be located as close as possible to the top of the column. For bottom product composition control he recommends that the sensor should be located in the liquid line to the reboiler. He has two main objections to placing the sensor on an intermediate plate:
 - a) The relationship between the composition of liquid on any intermediate plate and the composition of the top and bottom products is ambiguous.
 - b) The result reported by Uitti (31) that if the sensor is placed on an intermediate plate, an

increase in the feed composition could lead to decrease in composition in the top product, is odd and therefore undesirable for control purposes.

It is felt that with the current understanding of binary distillation column dynamics, Buckley's first objection is less valid than when originally stated. As for his second objection, it was found that the effect reported by Utti (31) was observed in this work, as can be seen in Figure 13, but it is felt that the direction of the offset to a given input disturbance is of little importance. The dynamic performance of this control scheme was quite good and should not be arbitrarily rejected.

- 6) Wherry and Berger (32) and Hoffman (14) point out some factors affecting the choice of sensor location for feedback top product composition control. Factors favouring placement of the sensor near the product stream are:
 - a) Less ambiguity in the correlation of sample composition to product composition.
 - b) Improved control loop behavior due to a reduction of transport lags (dead time).
 - c) Changes in composition at the sensor location and in the product stream occur almost at the same time and in the same direction, so stability is improved.

Factors favouring the placement of the sensor near the feed plate are:

- a) Improved terminal composition behavior due to earlier recognition of composition transients as they proceed from the feed plate towards the column terminals.**
- b) Analytical requirements are less stringent due to the fact that analysis of composition is made at lower concentrations and over a wider range.**

The authors suggest that a compromise plate should be chosen but do not specify how to make the compromise for best results.

The better performance claimed for sensing near the top of the column is based on the same arguments as that of Williams et al (24, 33, 34, 35) as discussed previously in point 4. The claim by Wherry and Berger (32) and Hoffman (14) that earlier sensing which is possible near the feed plate improves control of product composition seems questionable, and is flatly rejected by Harriott (13). The less stringent analytical requirements for sensors near the feed tray cannot be denied, but Harriott (13) points out instruments are available for high sensitivity work if that is necessary. However Harriott (13) does not point out that high sensitivity composition analyzers usually

have slow dynamic responses and often do not operate on a continuous basis.

- 7) Rosenbrock (26) proposed a completely different approach to locating the optimum control plate. He proposed that a disturbance function "D" should be minimized. In the case of one point feedback control the equations

$$X_c = X_f \pm \frac{1}{2}(X_D - X_U)$$

determine on which plate the sensor ought to be placed. Here X_c is the composition of the liquid on the control plate to be used. This criterion would suggest that the sensor should be placed on the 9-th plate for control of top product composition by reflux rate manipulation, and on the 3-rd plate for control of bottom product composition by reboil vapour rate manipulation. Results from the present work suggest that the sensor should be placed on the 7-th plate when controlling top product composition by reflux rate manipulation and on the 3-rd plate when controlling bottom product composition by reboil vapour rate manipulation. The fairly good agreement between these results suggests that even though Rosenbrock's criterion is for the minimization of disturbances throughout the column while this work simply wanted to minimize composition disturbances in the product streams, Rosenbrock's criterion may be a good guide for optimum sensor location when the objective is control of product stream compositions.

- 8) The significant improvement in performance of the instantaneous feedforward plus feedback control schemes over the corresponding schemes using feedback control alone, indicates that this combination may be of practical importance. The very simple type of controller involved in the feedforward path makes instantaneous feedforward plus feedback control easy to realize physically.
- 9) Control schemes 2-g to 2-j, which ensure no composition offset in one of the product streams, are desirable but they suffer from drift caused by secondary disturbances. This disadvantage makes these schemes less practical than the ones using integral control in the feedback loop to prevent drift in the controlled variable.
- 10) The oscillations in the bottom product composition when reflux rate was used to effect control were caused by the underdamped transfer function used to relate reflux rate to bottom product composition. In a real column the bottom product composition response would be overdamped, going to the final offset without any oscillations.

CONCLUSIONS

- 1) If the main objective is to control the top product composition, reflux rate manipulation should be used to effect control.
- 2) If the main objective is to control the bottom product composition, reflux rate manipulation should be used to effect control if the sensor is located above the feed plate and reboil rate manipulation should be used if the sensor is located below the feed plate.
- 3) It has been shown that optimum sensor location is a function both of the objectives of the control and of the particular scheme employed to achieve these objectives. It is felt that no single all-purpose recommendation is justified.

NOMENCLATURE

- C** - number of components
- D** - top product withdrawal rate, lb.-moles/min.
- e** - instantaneous error
- E** - defined by $\int_0^t e^2 dt$
- F** - feed rate, lb.-moles/min.
- G_c** - transfer function of controller
- G_{FF}** - feedforward functional
- G_{ij}** - transfer function between input j and output i
- G_L** - transfer function between the load variable and the controlled variable
- G_p** - transfer function of the process
- G_R** - transfer function of the reboiler
- G_v** - transfer function of the valve
- H** - transfer function of the sensing element
- H_{FF}** - transfer function of sensing element in feedforward path
- K** - gain
- K_c** - gain of controller
- K_{FF}** - gain of feedforward controller
- K_L** - gain of G_L
- K_H** - gain of sensing element
- K_p** - gain of process
- K_R** - gain of reboiler
- K_v** - gain of valve
- N** - number of plates above the feed plate

- M** - number of plates below the feed plate
- R** - reflux rate, lb.-moles/min.
- s** - Laplace transform operator
- T_i** - integral time constant
- V** - reboil vapour rate, lb.-moles/min.
- W** - bottom product withdrawal rate, lb.-moles/min.
- X_c** - Rosenbrock's control plate composition, mole % acetone
- X_D** - top product composition, mole % acetone
- X_F** - feed composition, mole % acetone
- X_j** - j-th plate liquid composition
- X_W** - bottom product composition
- Δ** - "change in"
- FB** - feedback
- FRC** - flow recorder and controller
- Inst. FF-FB** - Instantaneous feedforward plus feedback
- LLC** - liquid level controller
- M.D.** - maximum deviation
- Off.** - offset
- PRC** - pressure recorder and controller
- S.T.** - settling time
- TRC** - temperature recorder and controller

REFERENCES

1. Anisimov, I.V., "Automatic and Remote Control", Proceedings of the Second Congress of the International Federation of Automatic Control, Butterworths, London, 300-308, (1963).
2. Archer, D.H., and Rothfus, R.R., Chem. Eng. Prog. Symp. Series, 57, No. 36, 2-19, (1961).
3. Armstrong, M.A., and Wilkinson, W.L., Trans. Instn. Chem. Engrs., 35, 352-367, (1957).
4. Baber, M.F., Edwards Jr., L.L., Harper Jr., W.T., Witte, M.D., and Gerster, J.A., Chem. Eng. Prog. Symp. Series, 57, No. 36, 148-159, (1961).
5. Baber, M.F., and Gerster, J.A., A.I.Ch.E. Journal, 8, No. 3, 407-415, (1962).
6. Bauer, R.L., and Orr, C.P., Chem. Eng. Prog., 50, No. 6, 312-318, (1954).
7. Boyd Jr., D.M., Pet. Ref., 27, No. 11, 114-117, (1948).
8. Buckley, P.S., "Techniques of Process Control", J. Wiley & Sons Inc., (1964).
9. Forman, E.R., Chem. Eng., 72, No. 21, 203-208, (1965).
10. Forman, E.R., Chem. Eng., 72, No. 23, 213-218, (1965).
11. Fu, B. S-J., M.Sc. Thesis, Dept. of Chem. Eng., University of Ottawa, (1965).
12. Gould, L.A., Chem Eng. Prog. Symp. Series, 59, No. 46, 155-159, (1963).

13. Harriott, P., "Process Control", McGraw-Hill, New York, (1964).
14. Hoffman, H.L., Hyd. Proc. & Pet. Ref., 42, No. 2, 108-122, (1963).
15. Howard, G.M., Ind. Eng. Chem. Fundamentals, 6, No. 1, 86-89, (1967).
16. Huckaba, C.E., May, F.P., and Franke, F.R., Chem. Eng. Prog. Symp. Series, 59, No. 46, 38-47, (1963).
17. Huckaba, C.E., Franke, F.R., May, F.P., Fairchild, B.T., and Distefano, G.P., Chem. Eng. Prog. Symp. Series, 61, No. 55, 126-135, (1965).
18. Isawa, K., and Morinaga, T., "Automatic and Remote Control", Proceedings of the Second Congress of the International Federation of Automatic Control, Butterworths, London, (1963).
19. Lamb, D.E., Pigford, R.L., and Rippen, D.W.T., Chem. Eng. Prog. Symp. Series, 57, No. 36, 132-147, (1961).
20. Luyben, W.L., Verneuil Jr., V.S., and Gerster, J.A., "Transient Response of Ten-Tray Distillation Column: Complete Data and Results", Dept. of Chem. Eng., University of Delaware, (1963).
21. Luyben, W.L., Verneuil Jr., V.S., and Gerster, J.A., A.I.Ch.E. Journal, 10, No. 3, 357-363, (1964).
22. Luyben, W.L., and Gerster, J.A., Ind. Eng. Chem., Process Design and Development, 3, 374-381, (1964).

23. Pyle, C., Oil & Gas Journal, 48, No. 23, 97-103, (1949).
24. Rose, A., and Williams, T.J., Ind. Eng. Chem., 47, No. 11, 2284-2289, (1955).
25. Rosenbrock, H.H., Trans. Instn. Chem Engrs., 35, 347-351, (1957).
26. Rosenbrock, H.H., Trans. Instn. Chem. Engrs., 40, 35-53, (1962).
27. Rosenbrock, H.H., Brit. Chem. Eng., 364-367, 432-435, 491-494, (1958).
28. Slotboom, H.W., DeJong, J.J., Landstra, J.A., Rijnsdorp, J.E., and Timmers, A.C., "Automatic and Remote Control", Proceedings of the Second Congress of the International Federation of Automatic Control, 222-228, (1963).
29. Sproul, J.S., and Gerster, J.A., Chem. Eng. Prog. Symp. Series, 59, No. 46, 21-31, (1963).
30. Tivy, St. L., Pet. Ref., 27, No. 11, 123-128, (1948).
31. Utti, K.D., Pet. Ref., 29, No. 3, 130-134, (1950).
32. Wherry, T.C., and Berger, D.E., Pet. Ref., 37, No. 5, 219-224, (1958).
33. Williams, T.J., Harnett, R.T., and Rose, A., Ind. Eng. Chem., 48, No. 6, 1008-1019, (1956).
34. Williams, T.J., and Harnett, R.T., Chem. Eng. Prog., 53, No. 5, 220-225, (1957).
35. Williams, T.J., Ind. Eng. Chem., 50, No. 9, 1214-1222, (1958).

36. Williams, T.J., Ind. Eng. Chem., 55, No. 11, 43-45, (1963).
37. Williams, T.J., Ind. Eng. Chem., 56, No. 11, 47-56, (1964).
38. Williams, T.J., Ind. Eng. Chem., 57, No. 12, 33-43, (1965).
39. Williams, T.J., Ind. Eng. Chem., 58, No. 12, 55-70, (1966).

APPENDIX - A

- 1) Steady state operating conditions**
- 2) Comparison of Gerster's data with
the model used in this work**

Steady state operating conditions in the column

System: acetone-benzene

Column pressure: 25 psig

Feed rate, F: 1.087 lb.-moles/min.

Overhead product rate, D: 0.594 lb.-moles/min.

Bottom product rate, W: 0.493 lb.-moles/min.

Reflux rate: 0.968 lb.-moles/min.

Reboil vapour rate: 2.07 lb.-moles/min.

Reflux ratio: 1.63

Feed composition, X_F : 49.0 mole % acetone

Top product composition, X_D : 83.4 mole % acetone

Composition on plate 9, X_9 : 70.5 mole % acetone

Composition on plate 7, X_7 : 57.0 mole % acetone

Composition on plate 5, X_5 : 45.8 mole % acetone

Composition on plate 3, X_3 : 30.8 mole % acetone

Composition on plate 1, X_1 : 12.3 mole % acetone

Bottom product composition, X_W : 3.8 mole % acetone

Feed enters the column on the 5-th plate.

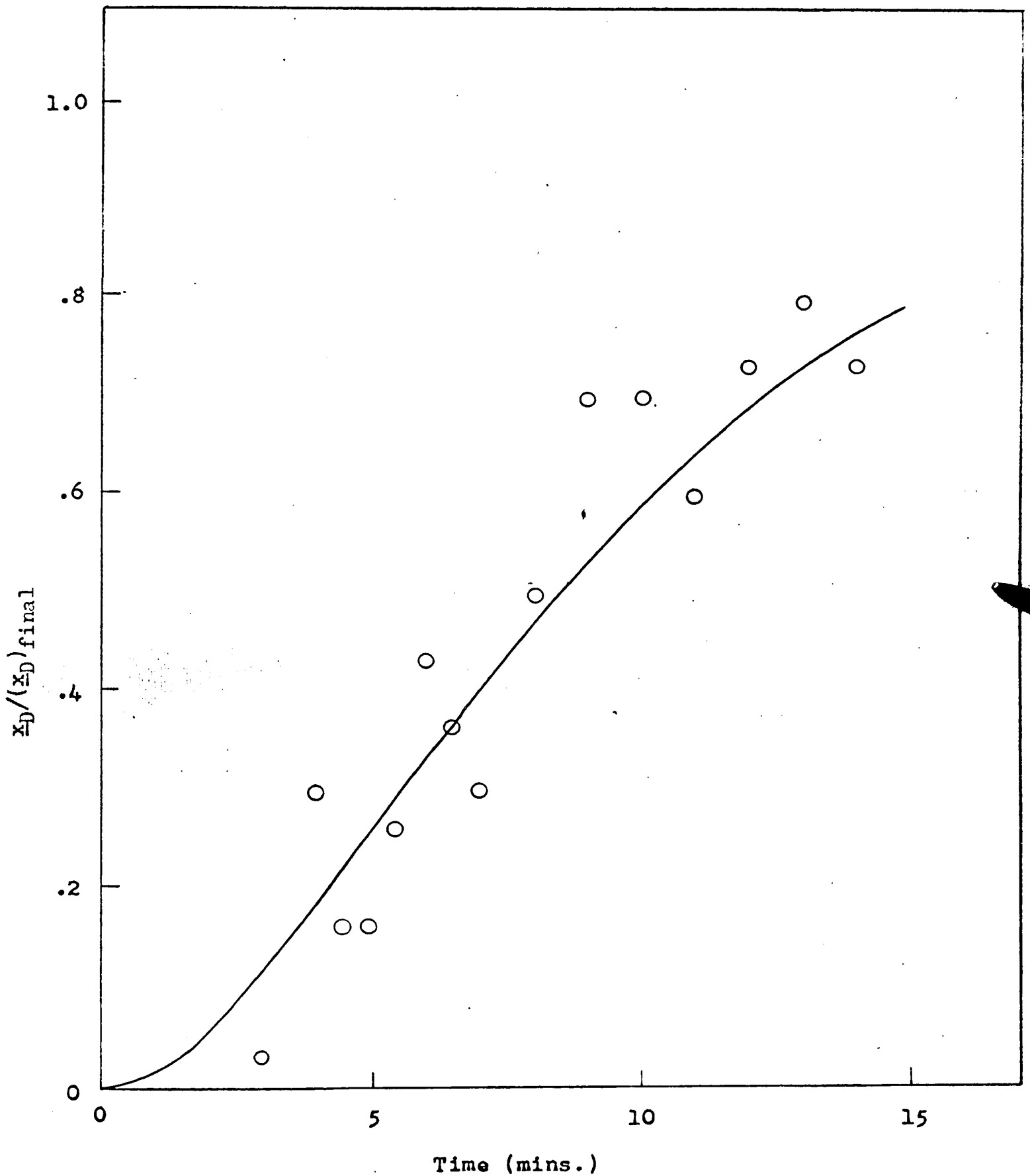

Fig. 52 Normalized transient response of x_D to a step change in reboil vapour rate.

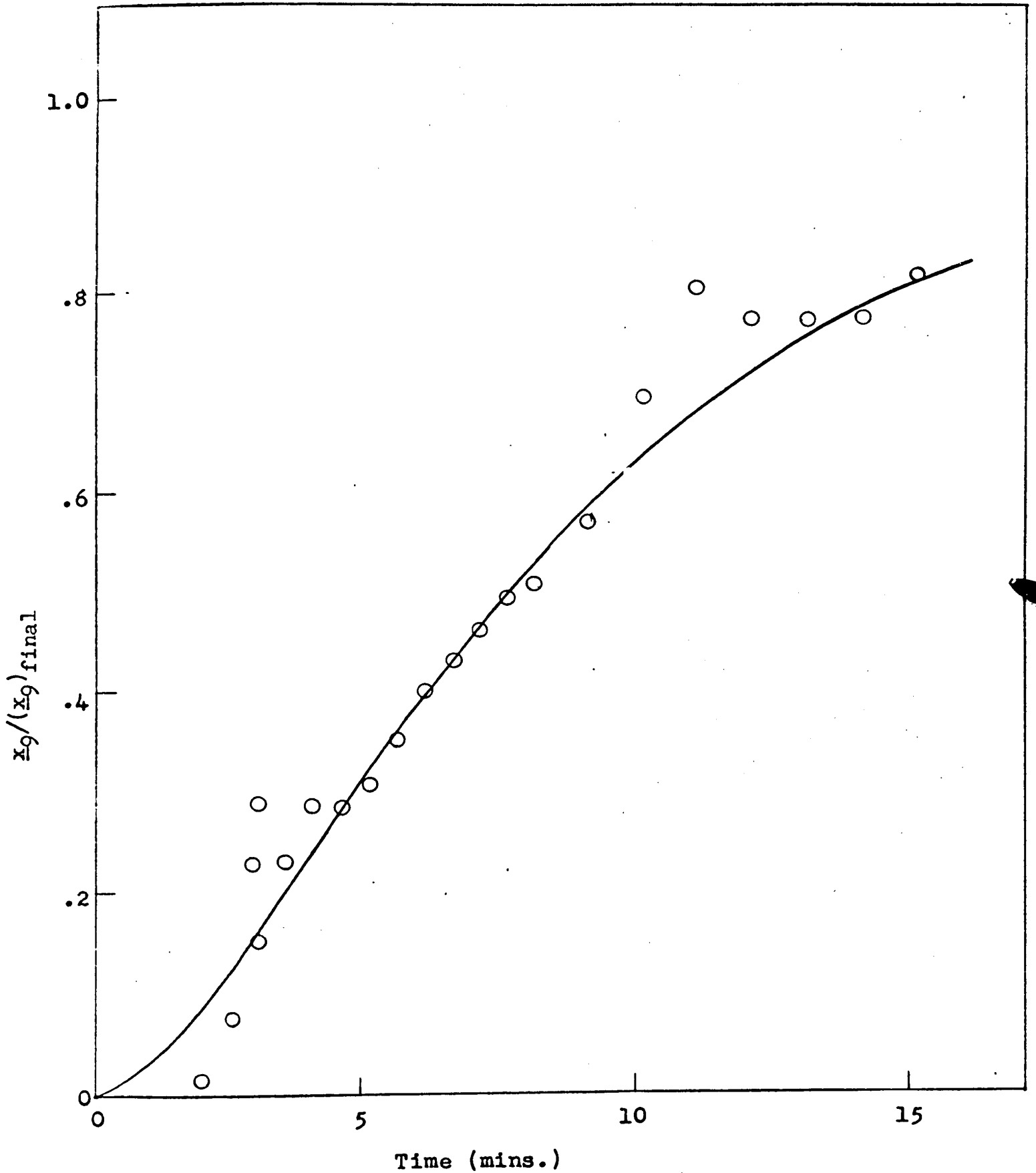

Fig. 53 Normalized transient response of x_g to a step change in reboil vapour rate

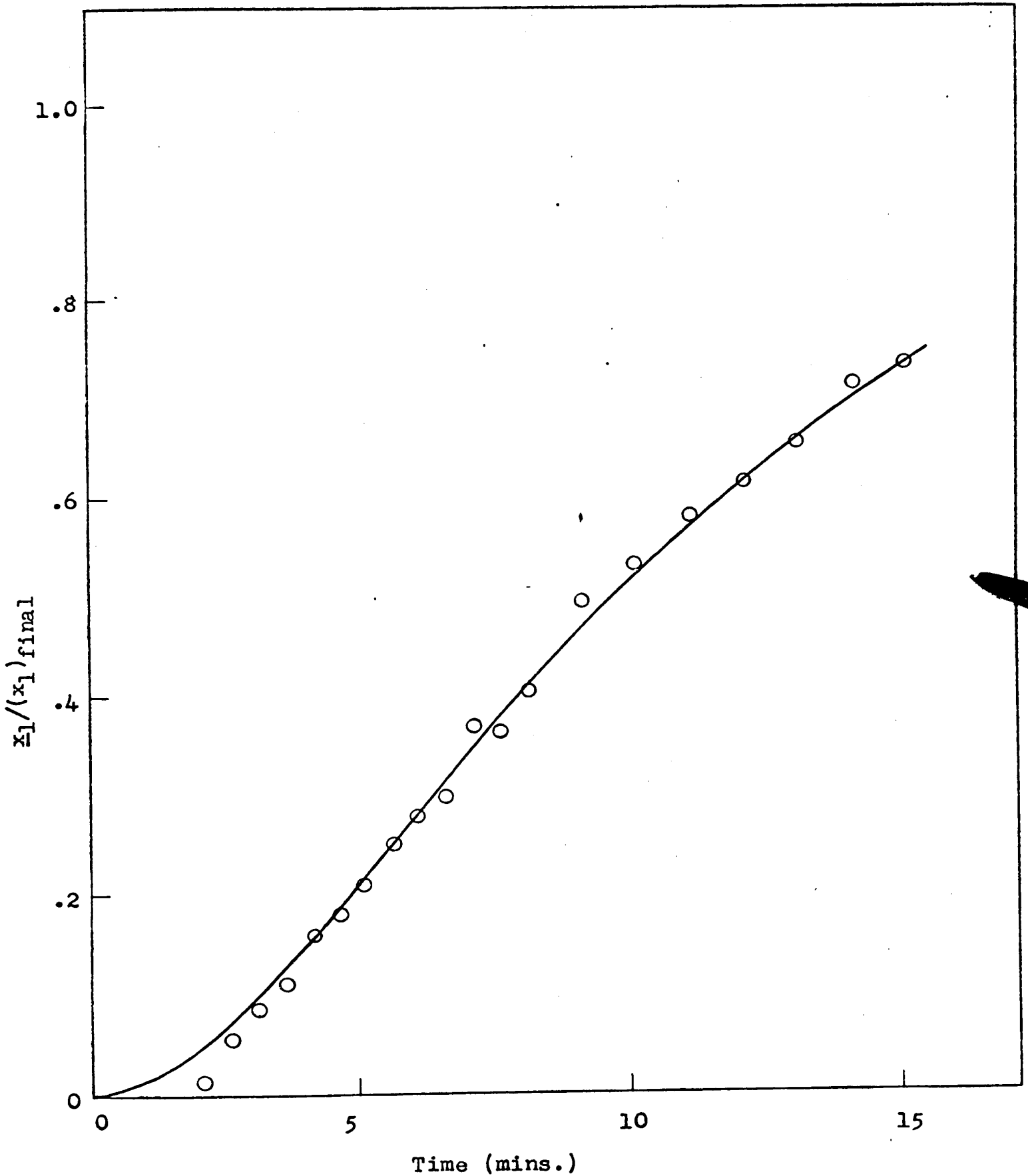

Fig. 54 Normalized transient response of x_1 to a step change in reboil vapour rate

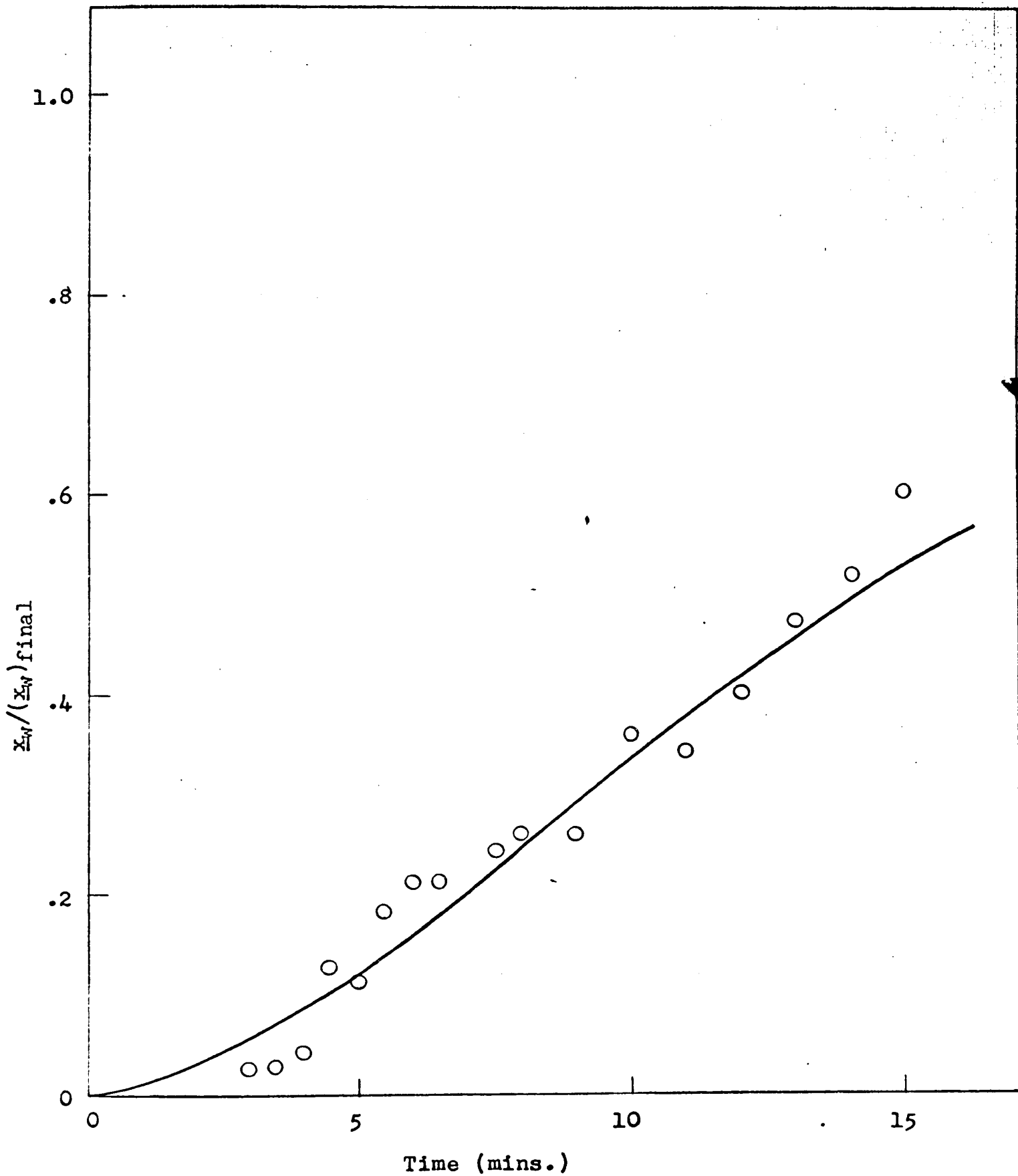

Fig. 55 Normalized transient response of x_w to a step change in reboil vapour rate

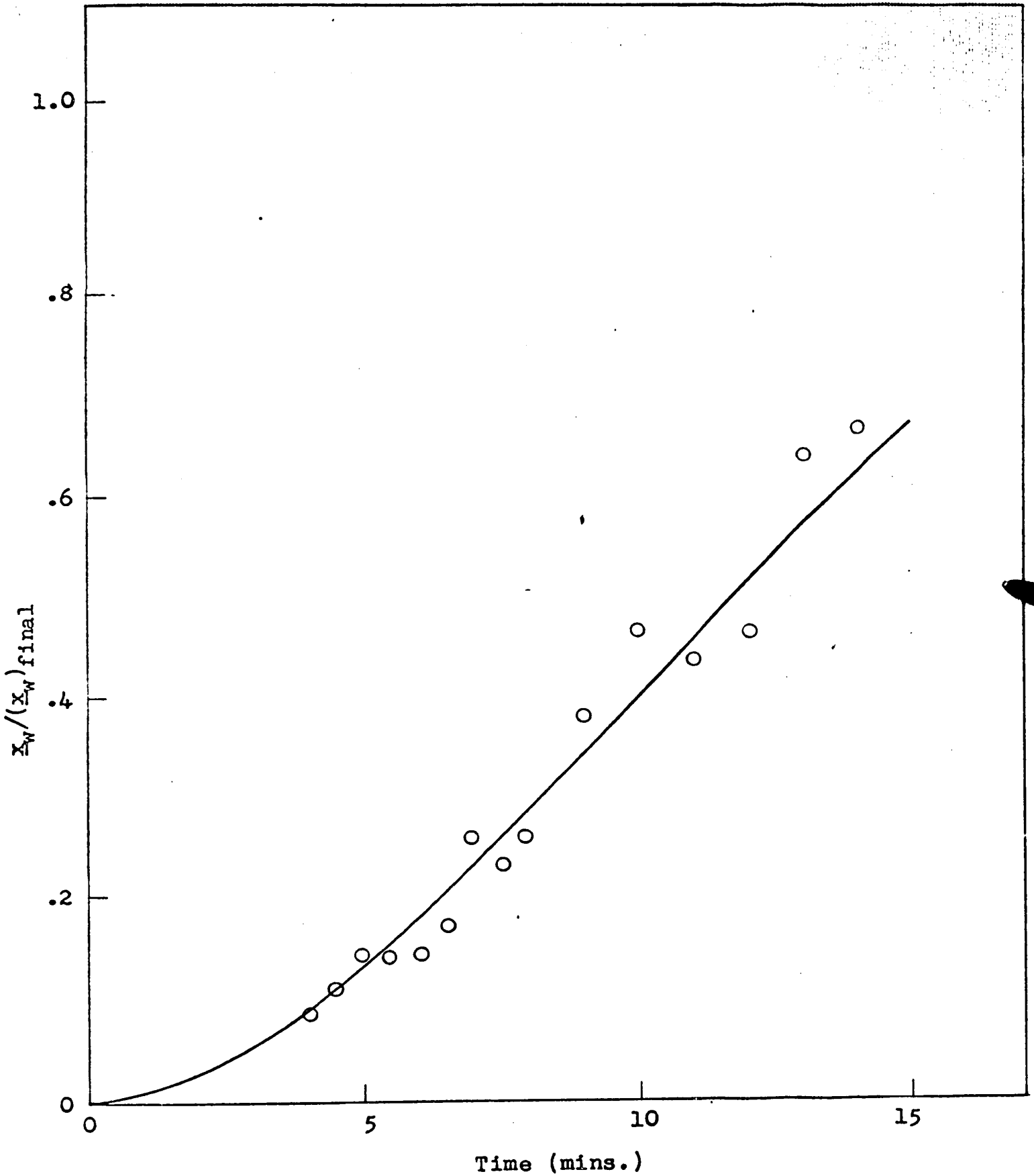

Fig.56 Normalized transient response of x_w to a step change in reflux rate

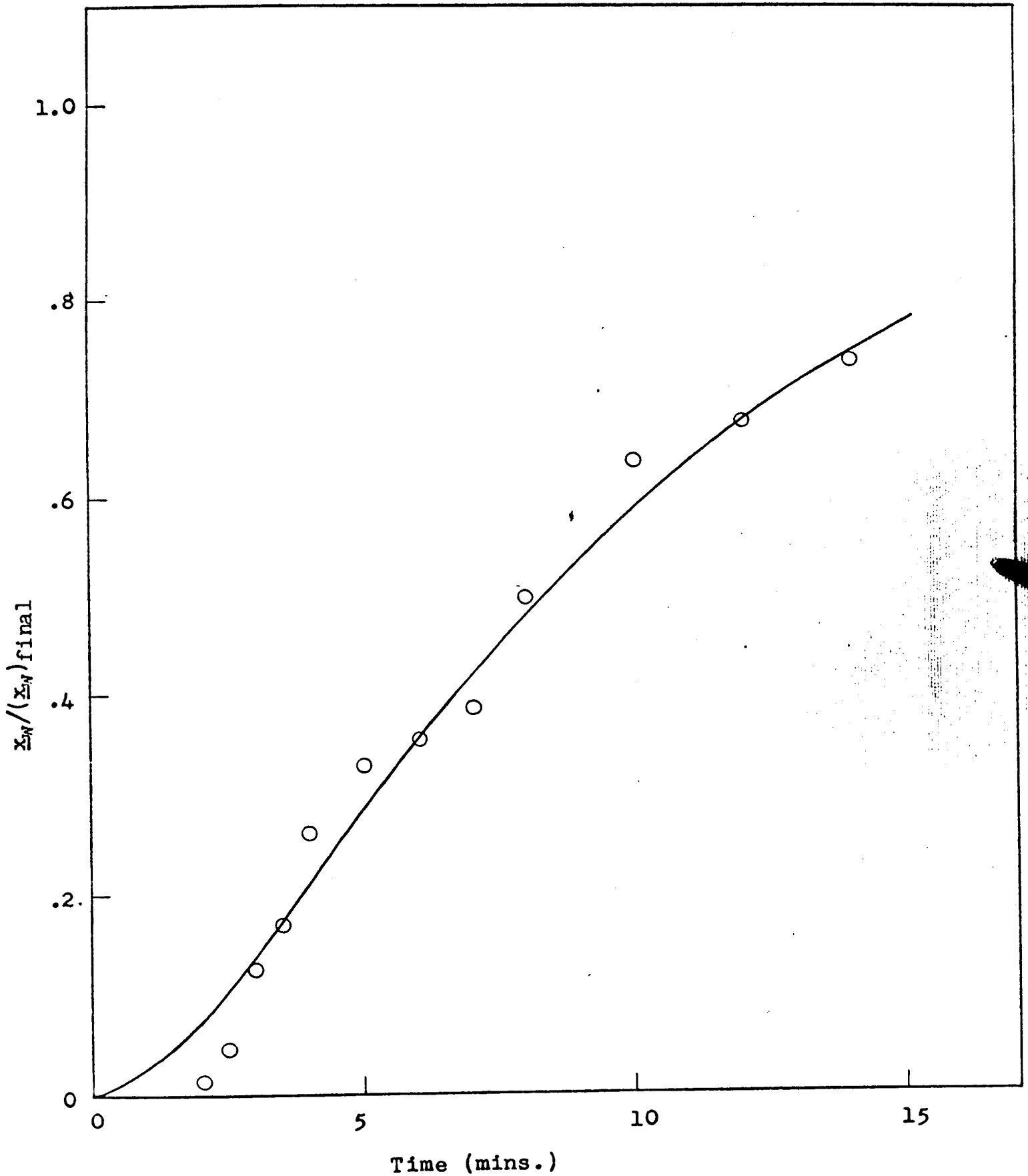

Fig. 57 Normalized transient response of x_w to a step change in feed composition

APPENDIX - B

- 1) Optimum control parameters**
- 2) Stability range of feedback control schemes**

Optimum control parameters

Control scheme	K	1/ T₁	K_{FF}
1-a	200	0.125	-
1-b	27.5	0.02	-
1-c j=9	40	0.15	-
j=7	22.5	0.10	-
j=3	15	0.10	-
j=1	30	0.225	-
1-d	19	0.06	-
1-e	13	0.03	-
1-f j=9	10	0.07	-
j=7	11	0.10	-
j=3	5	0.105	-
j=1	5	0.05	-
2-a	190	-	1.87
2-b	25	-	3.10
2-c j=9	35	-	1.96
j=7	25	-	1.83
j=3	15	-	1.92
j=1	30	-	1.37
2-d	16	-	2.11
2-e	14	-	1.33
2-f j=9	6.5	-	2.03
j=7	11	-	2.11

Control scheme	K	1/ T ₁	K _{FF}
2-f j=3	3	-	1.61
j=1	6	-	0.87
2-g j=9	0.45	-	1.91
j=7	1.0	-	1.88
j=3	2.0	-	1.80
j=1	0.2	-	1.98
2-h j=9	14	-	3.36
j=7	16	-	2.68
j=3	5.0	-	5.44
j=1	0.5	-	2.94
2-1 j=9	15	-	13.62
j=7	6.0	-	10.25
j=3	6.0	-	10.7
j=1	0.2	-	3.46
2-h j=9	0.01	-	1.30
j=7	0.01	-	1.29
j=3	0.002	-	1.31
j=1	2.5	-	2.70

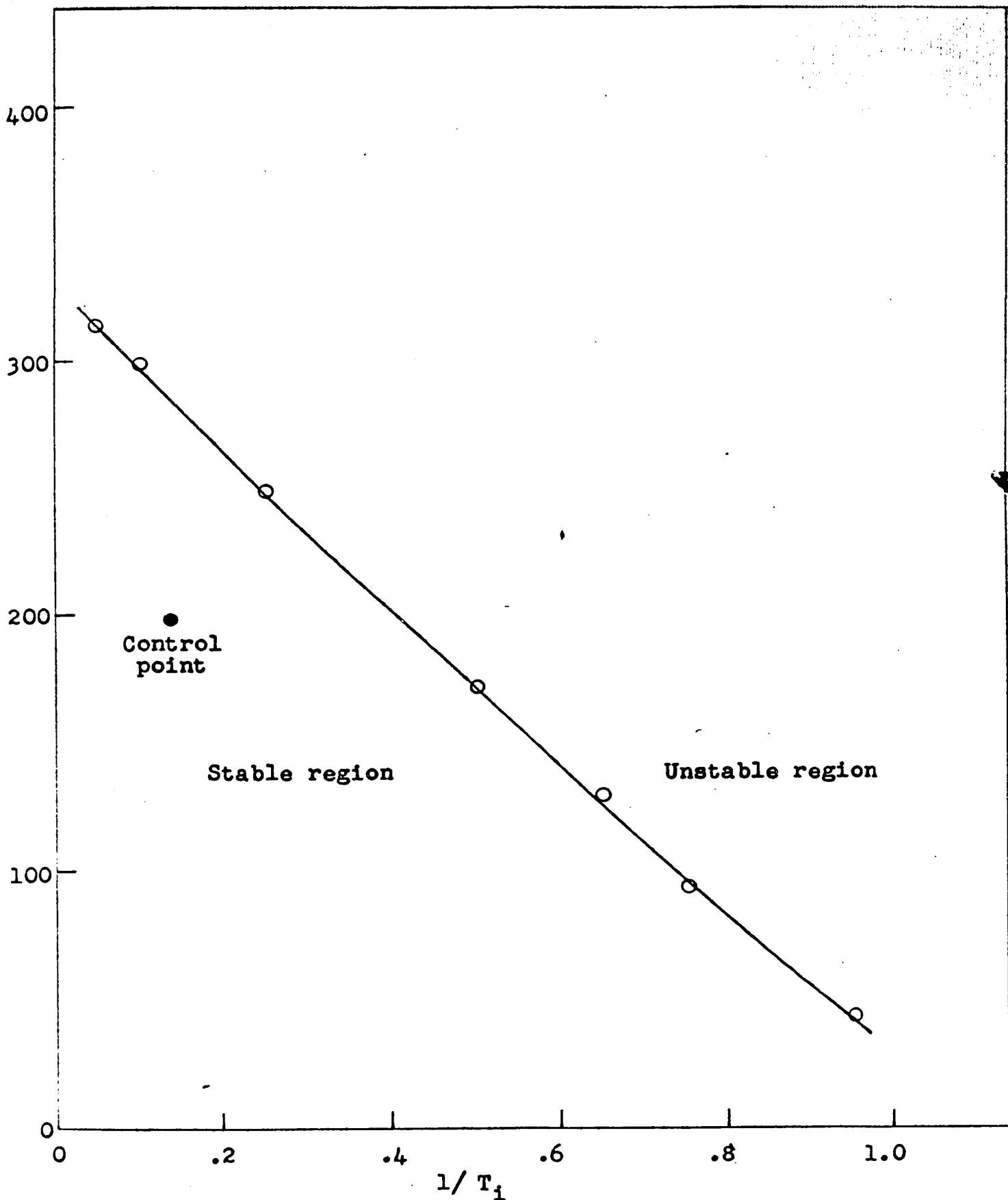

Fig. 58 Stability range of the controller when x_D is controlled by reflux rate

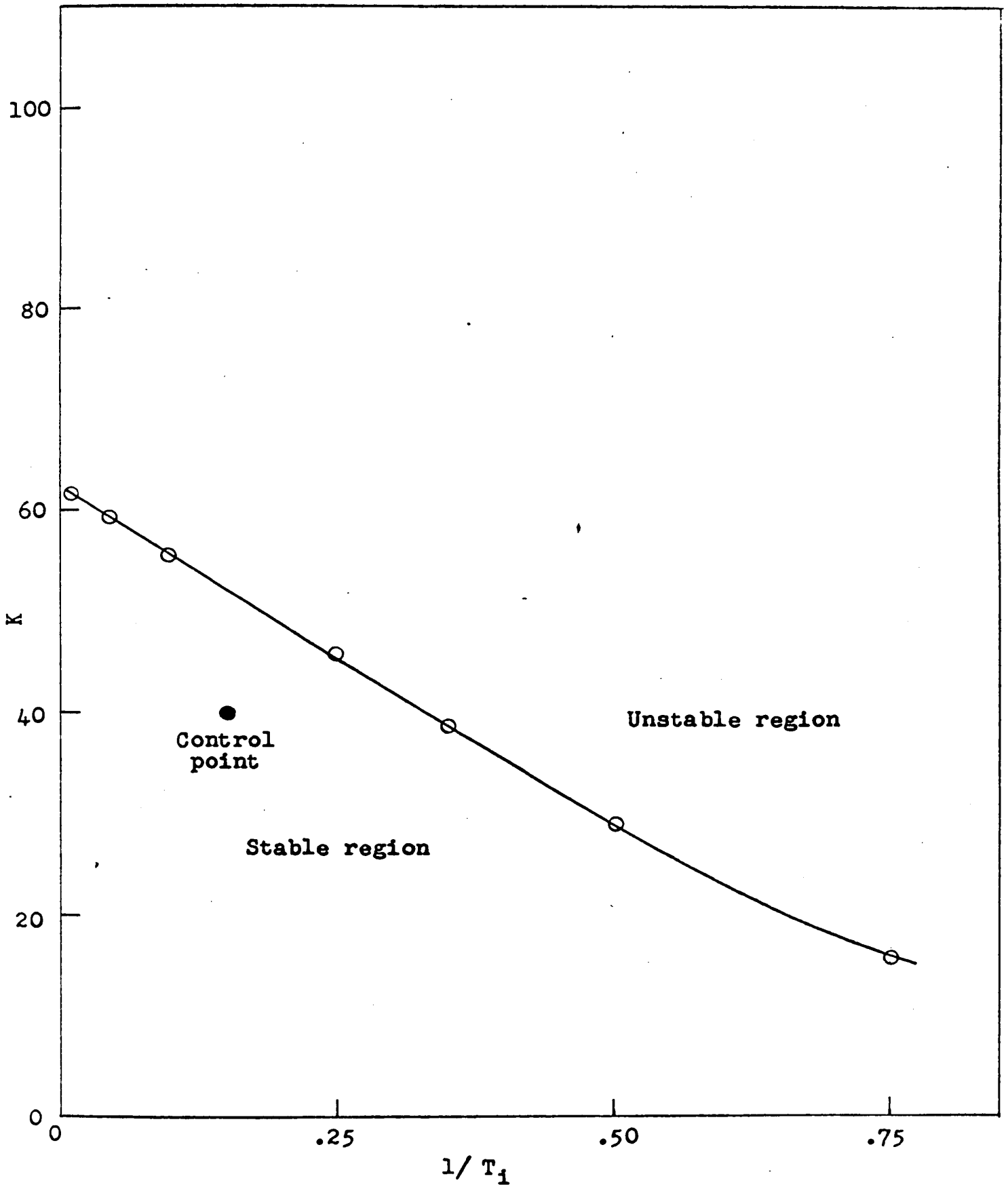

Fig. 59 Stability range of the controller when x_9 is controlled by reflux rate

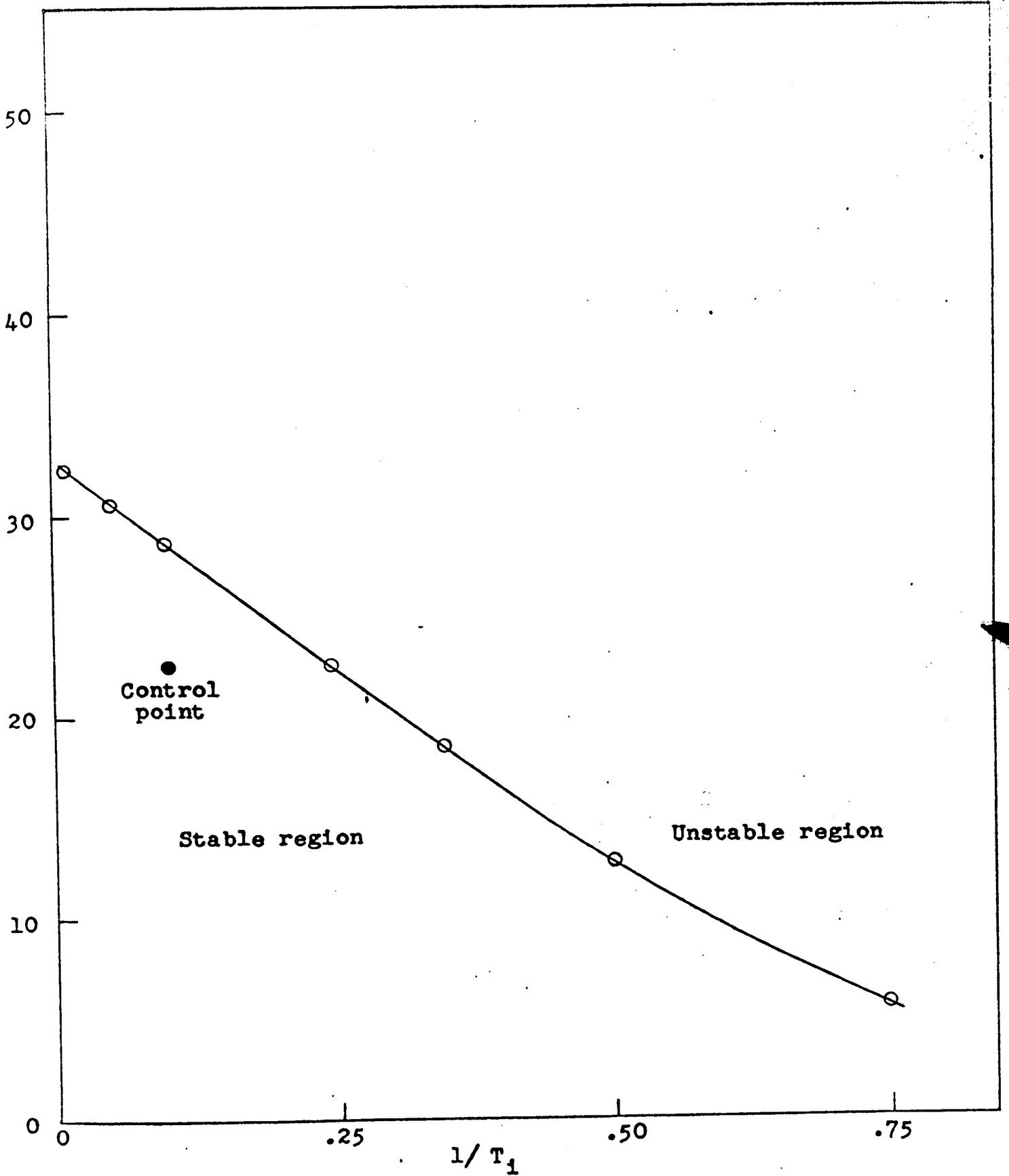

Fig. 60 Stability range of the controller when x_7 is controlled by reflux rate

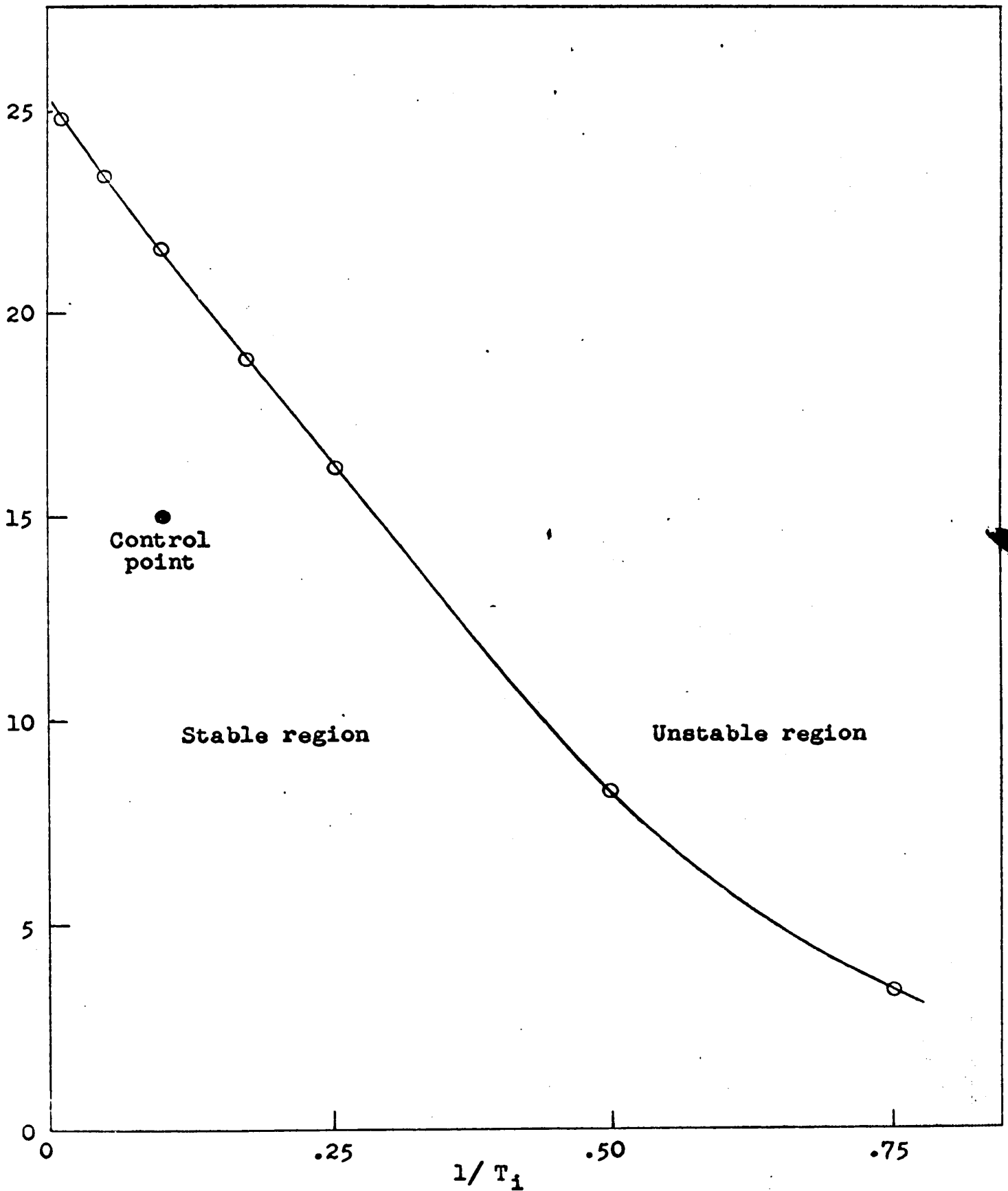

Fig. 61 Stability range of the controller when x_3 is controlled by reflux rate

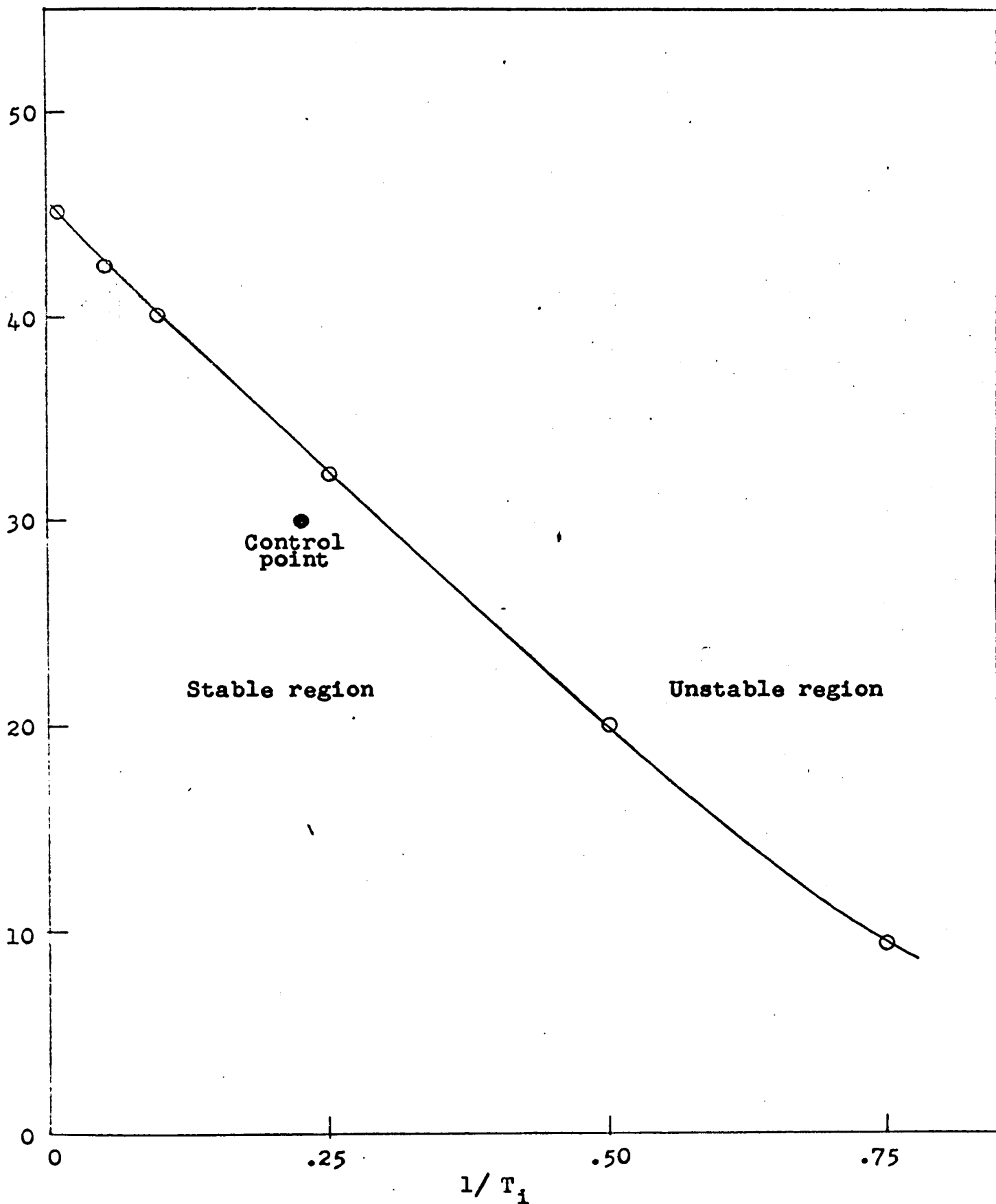

Fig. 62 Stability range of the controller when x_1 is controlled by reflux rate

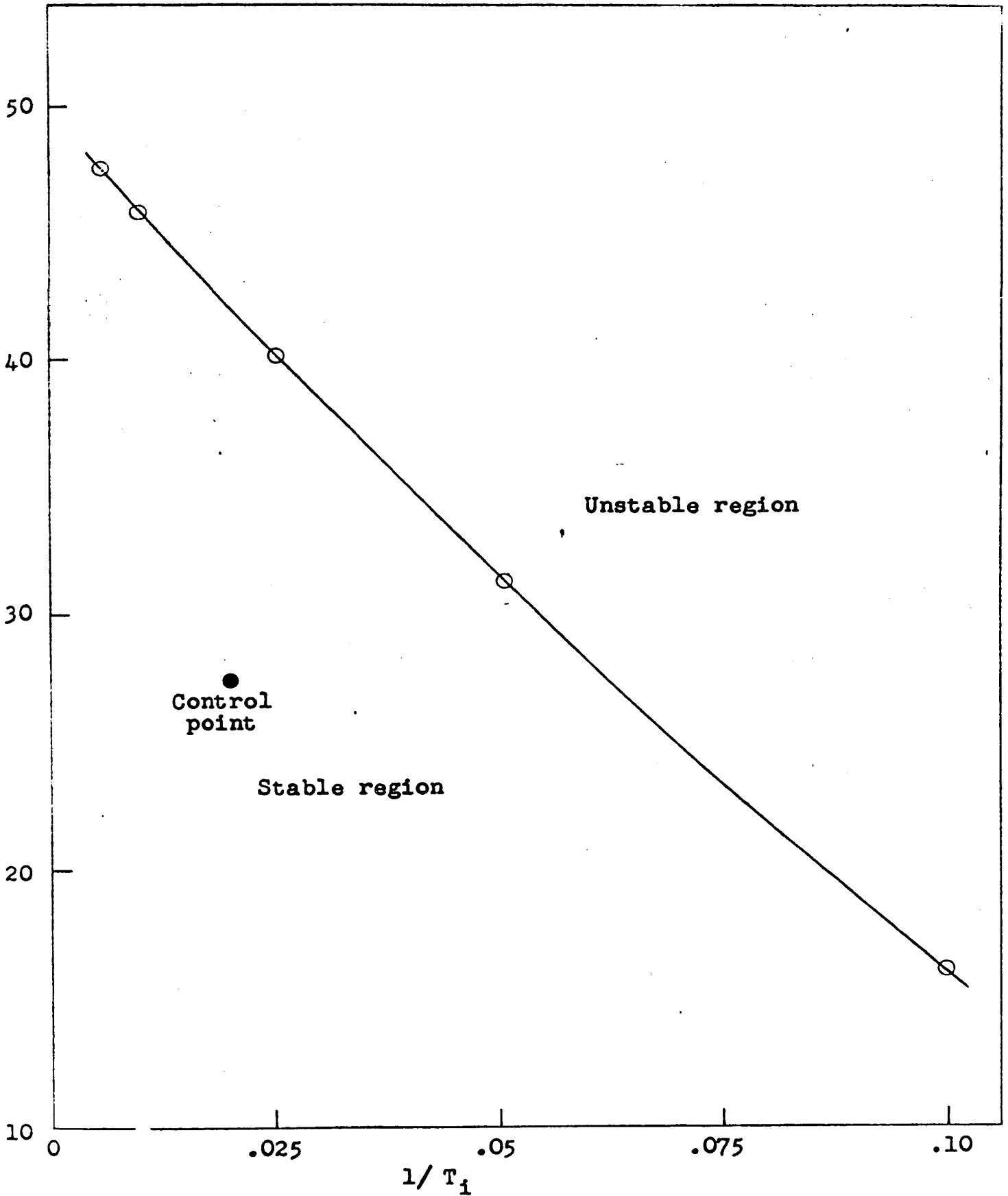

Fig. 63 Stability range of the controller when x_w is controlled by reflux rate

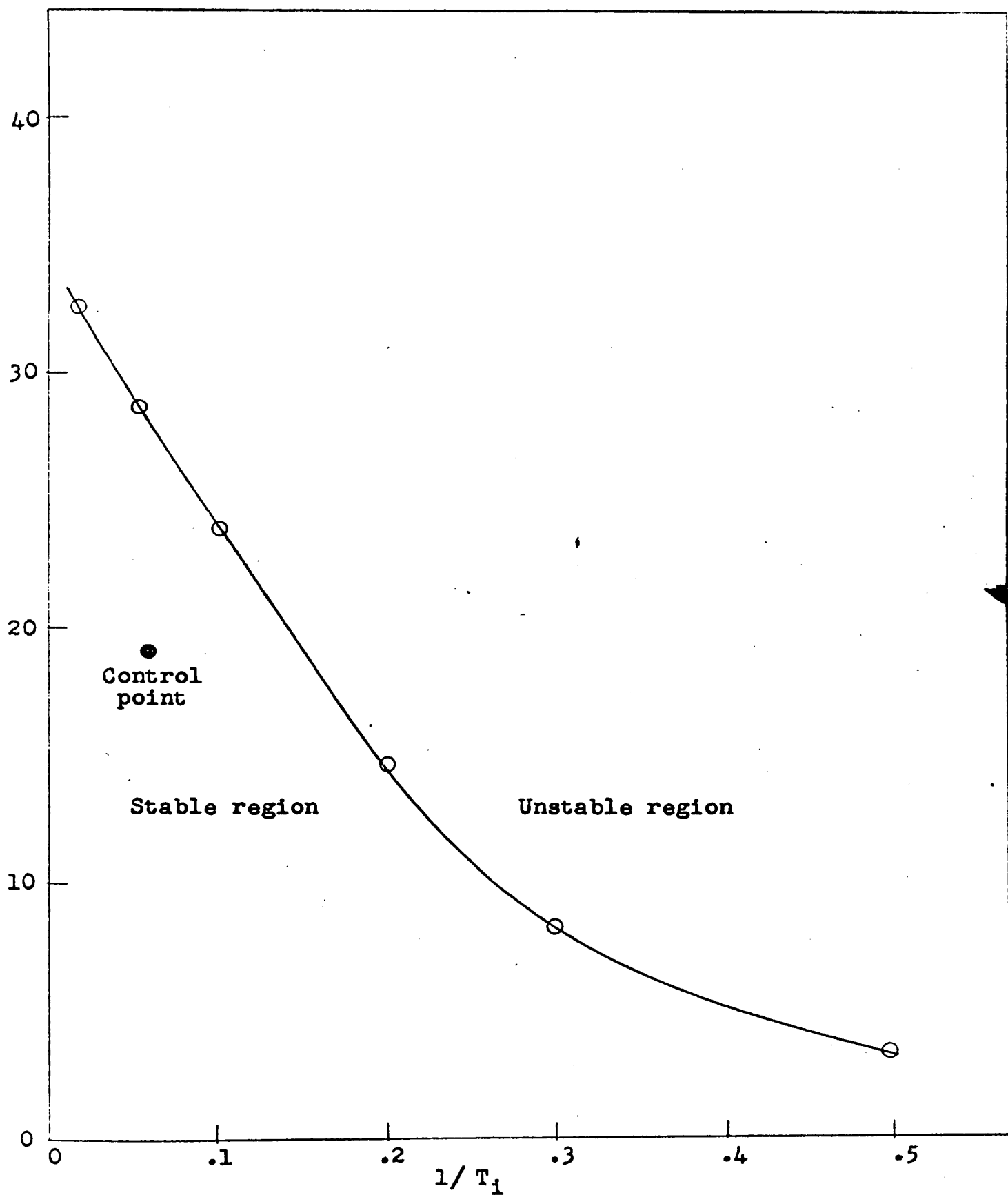

Fig. 64 Stability range of the controller when x_D is controlled by reboil vapour rate

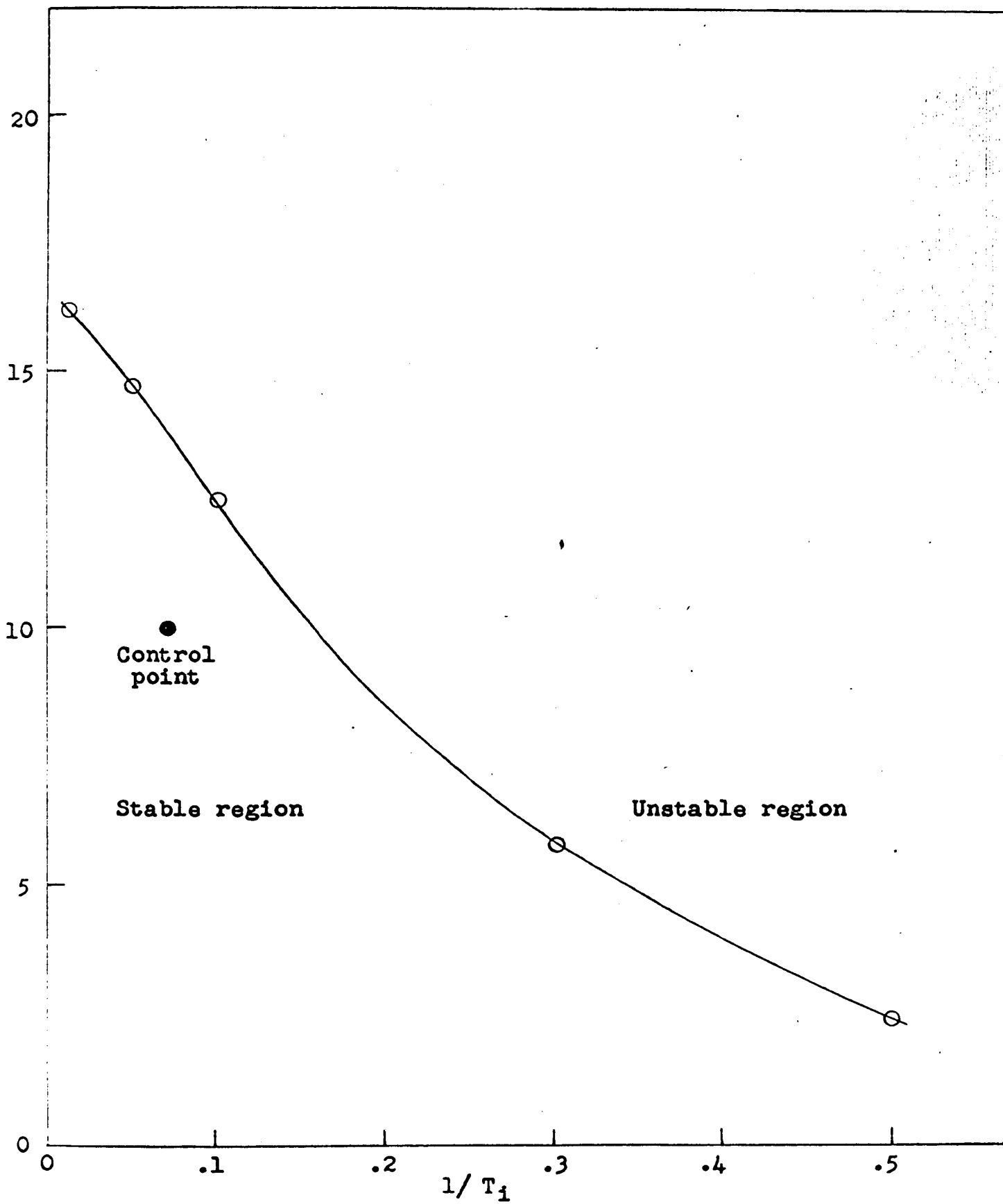

Fig.65 Stability range of the controller when x_9 is controlled by reboil vapour rate

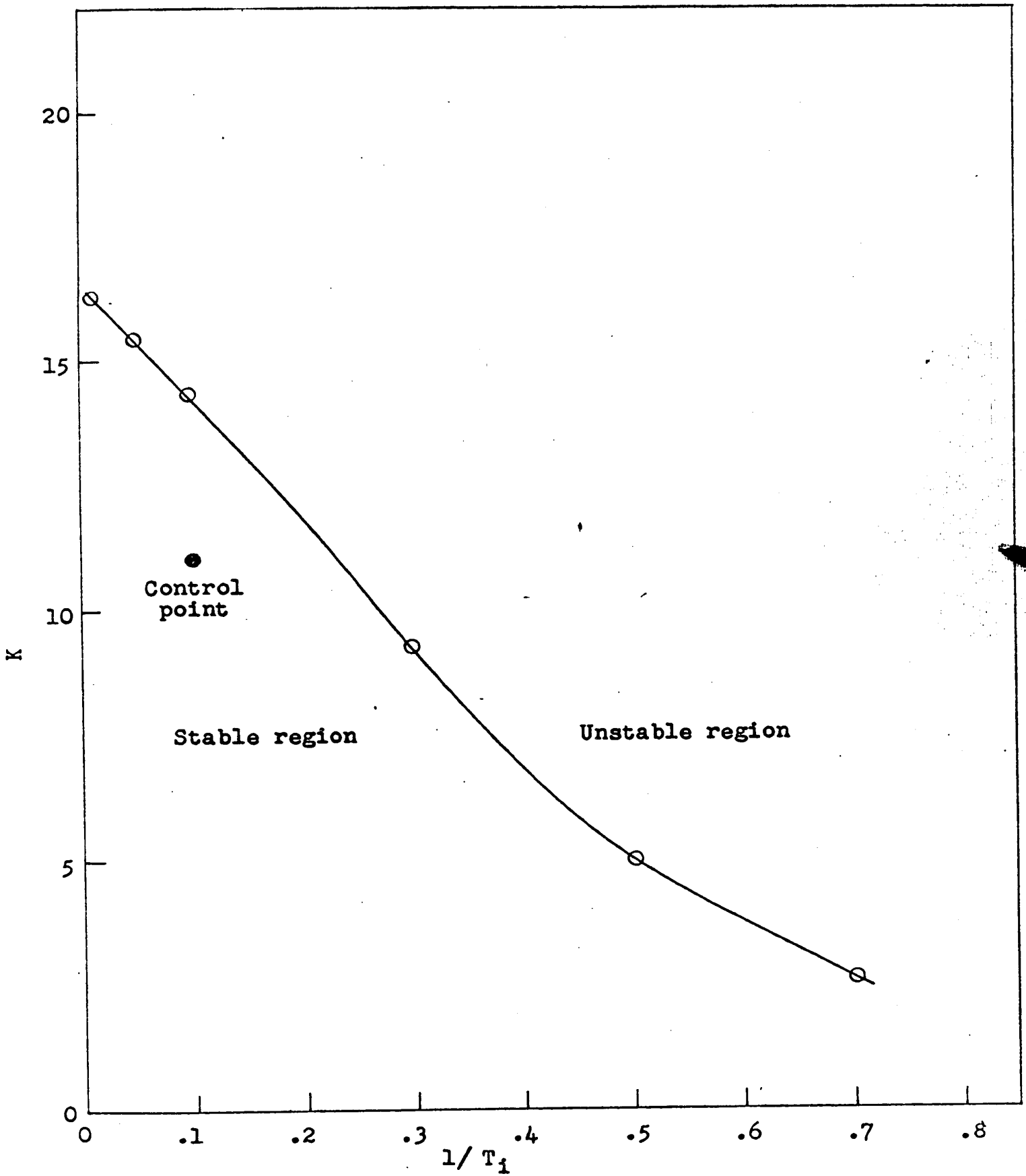

Fig. 66 Stability range of the controller when x_7 is controlled by reboil vapour rate

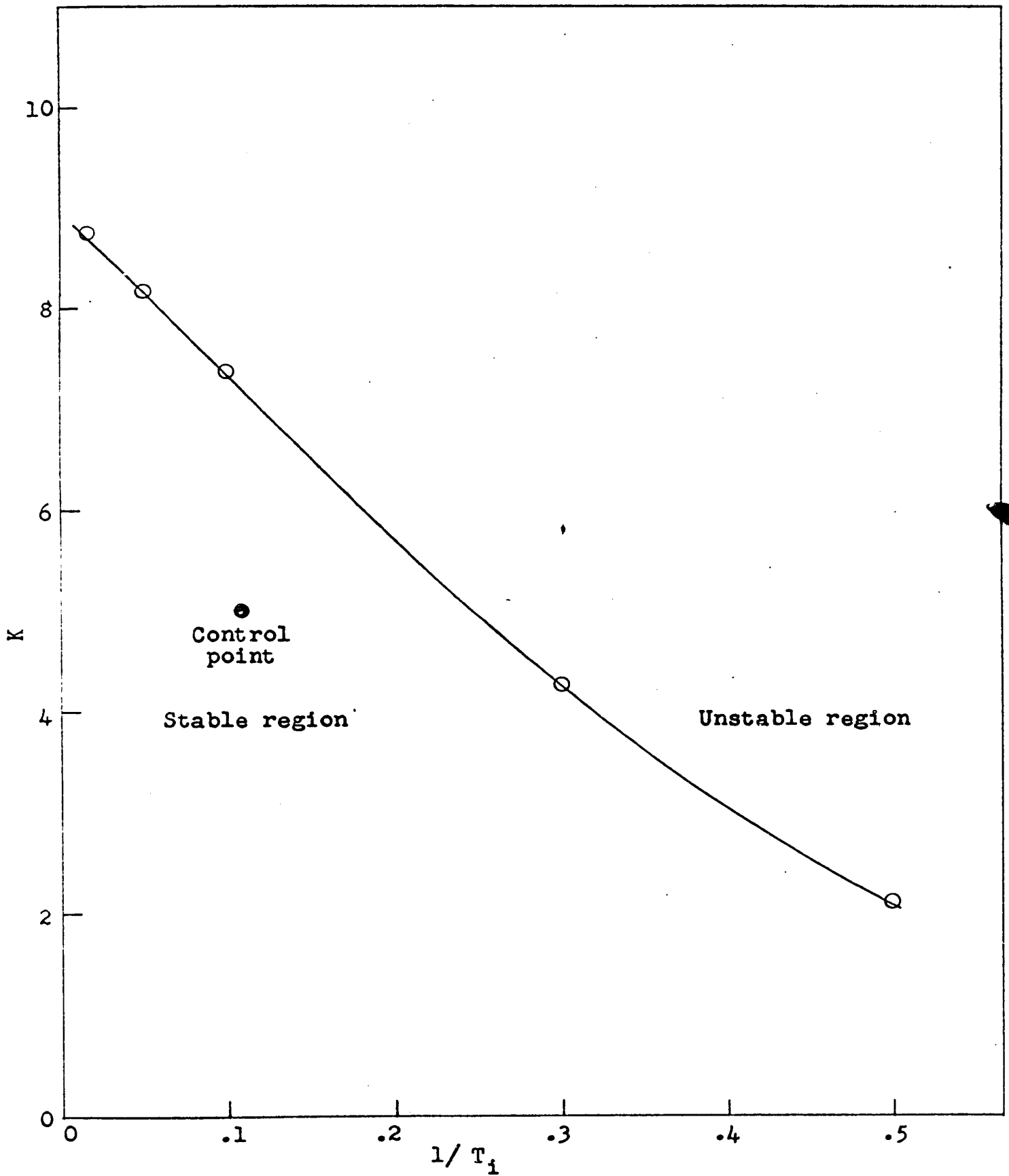

Fig. 67 Stability range of the controller when x_3 is controlled by reboil vapour rate.

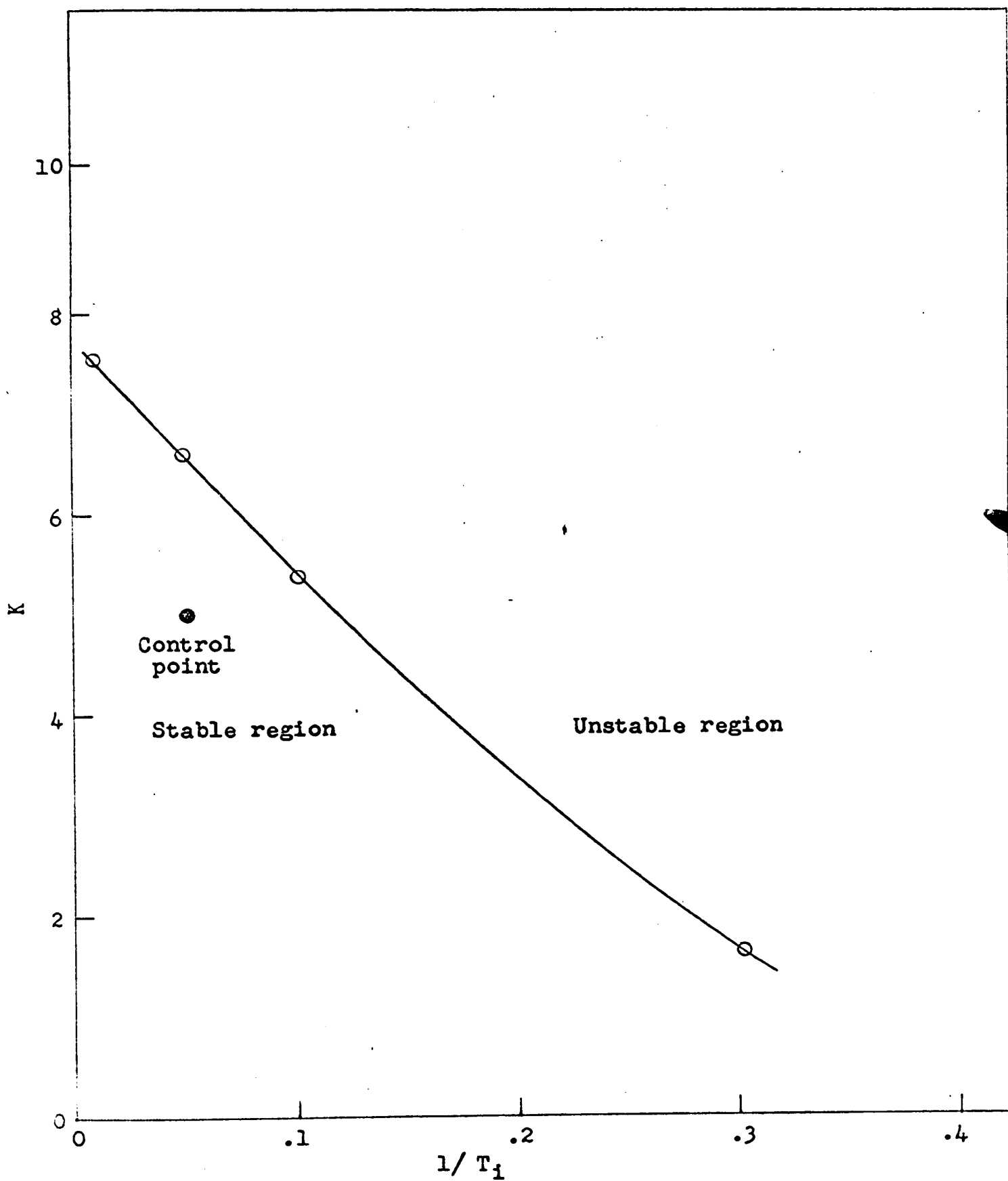

Fig.68 Stability range of the controller when x_1 is controlled by reboil vapour rate

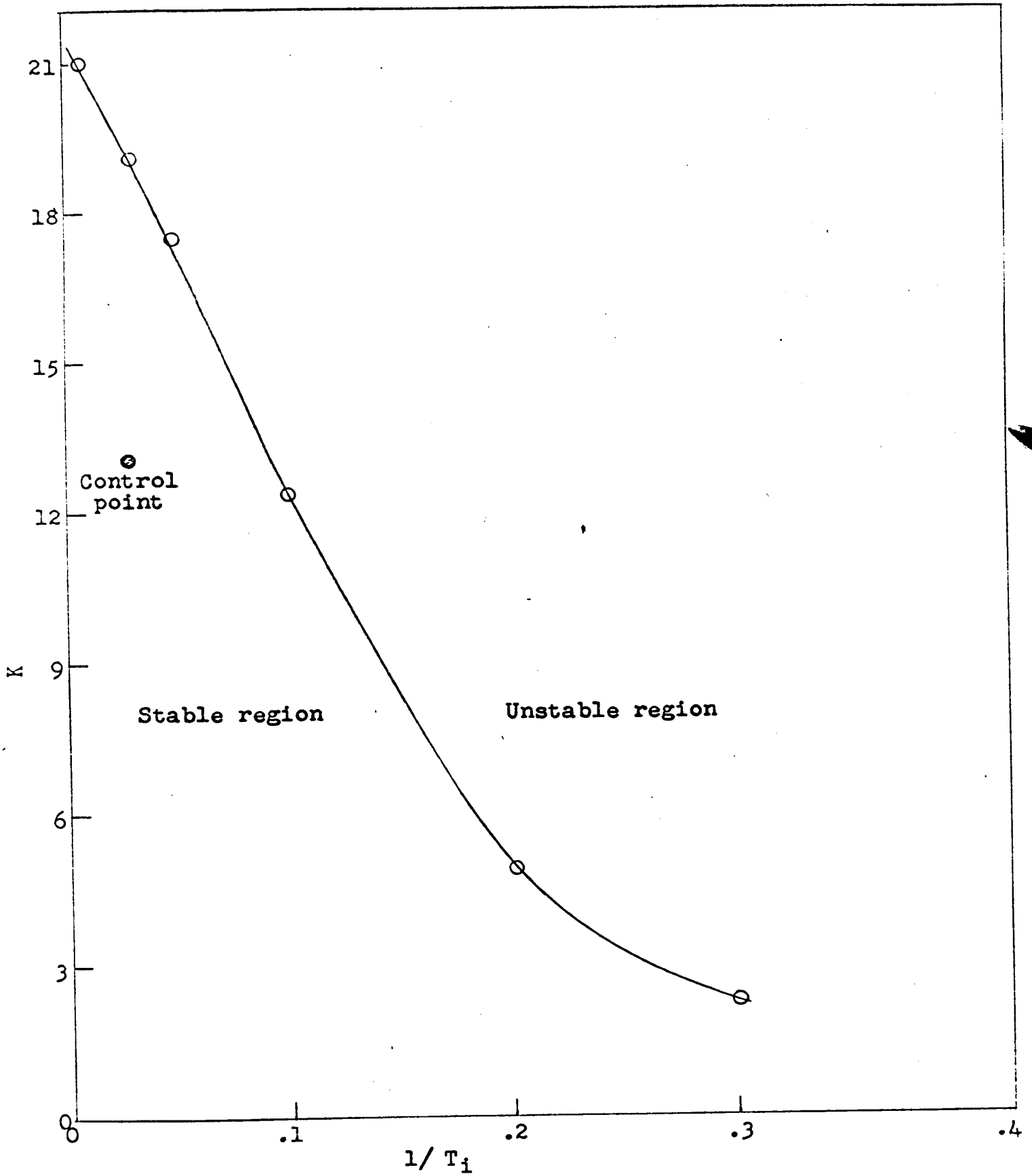

Fig. 69 Stability range of the controller when x_w is controlled by reboil vapour rate

APPENDIX - C

- 1) Analog computer circuits**
- 2) Potentiometer settings**

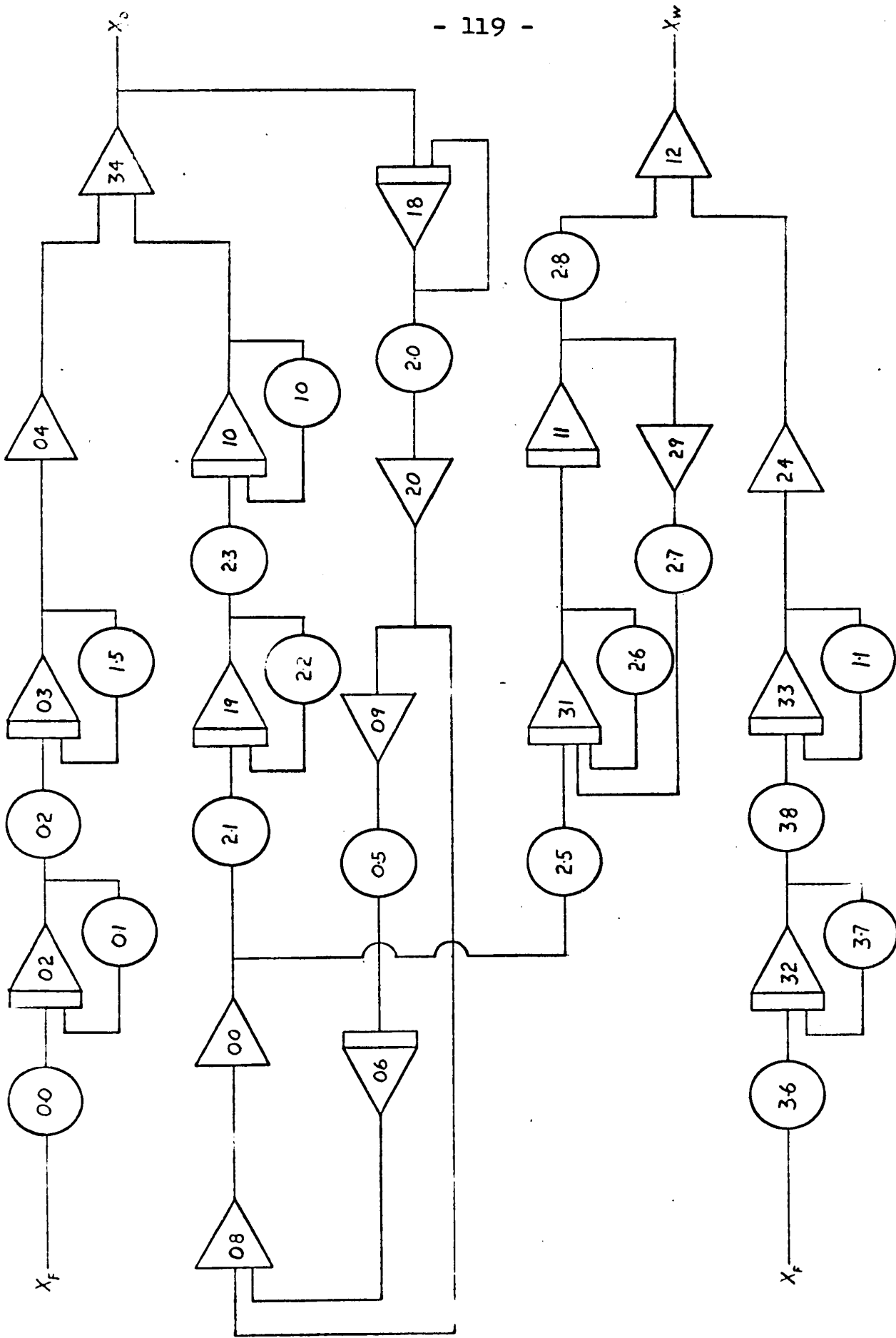

Figure 70. Analog computer circuit for control scheme 1-a

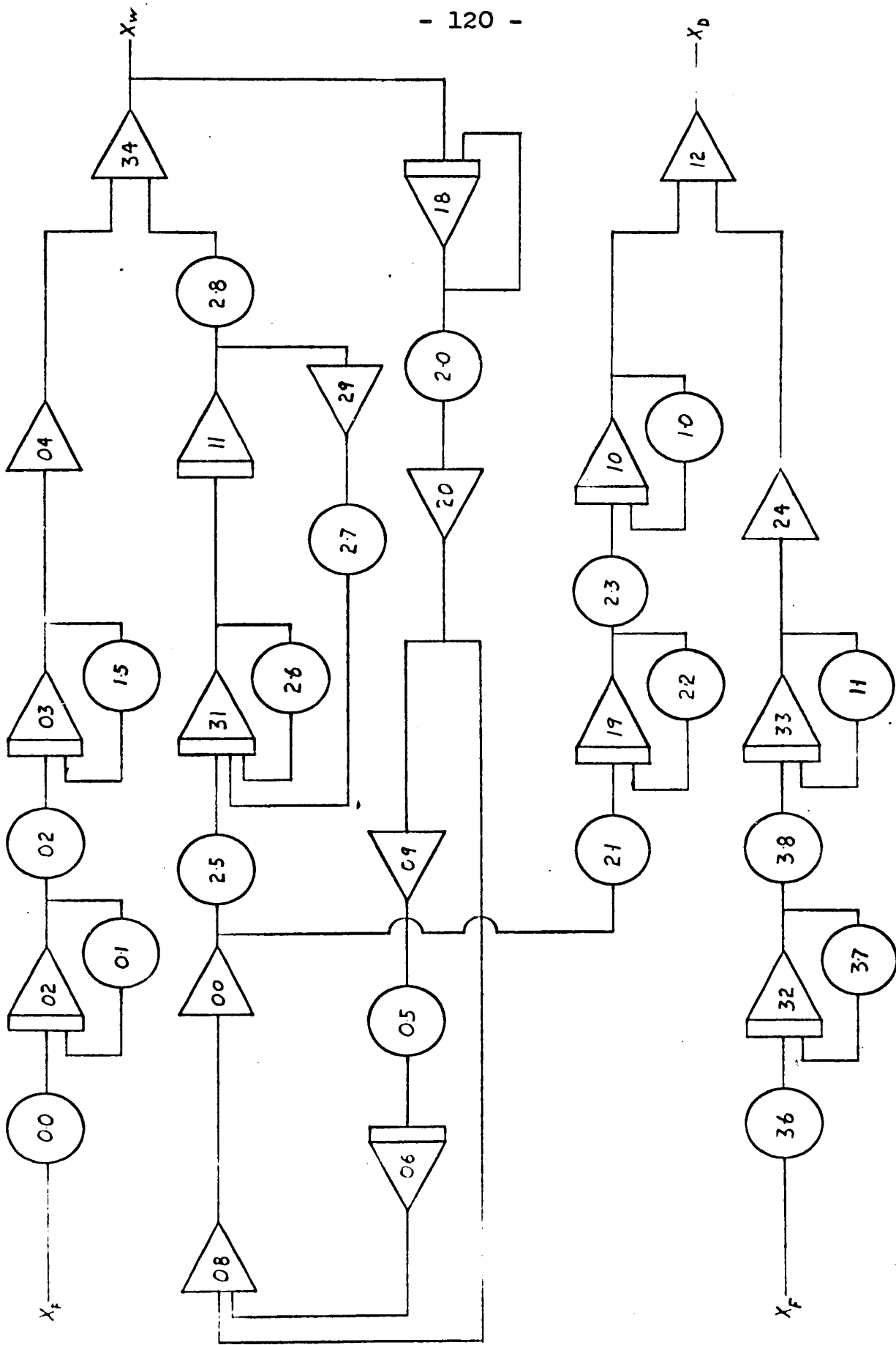

Figure 71. Analog computer circuit for control scheme 1-b

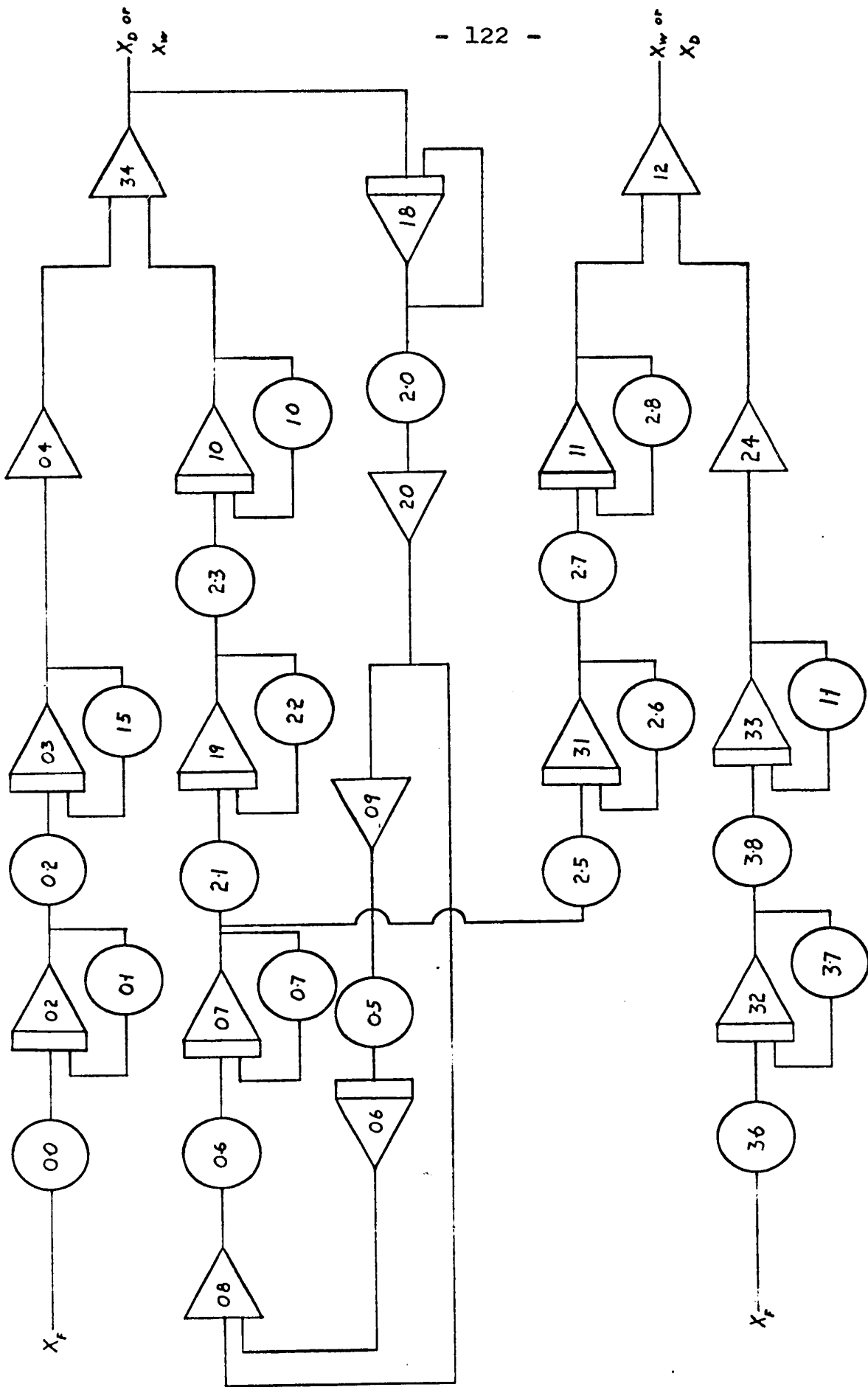

Figure 73. Analog computer circuit for control schemes 1-d and 1-e

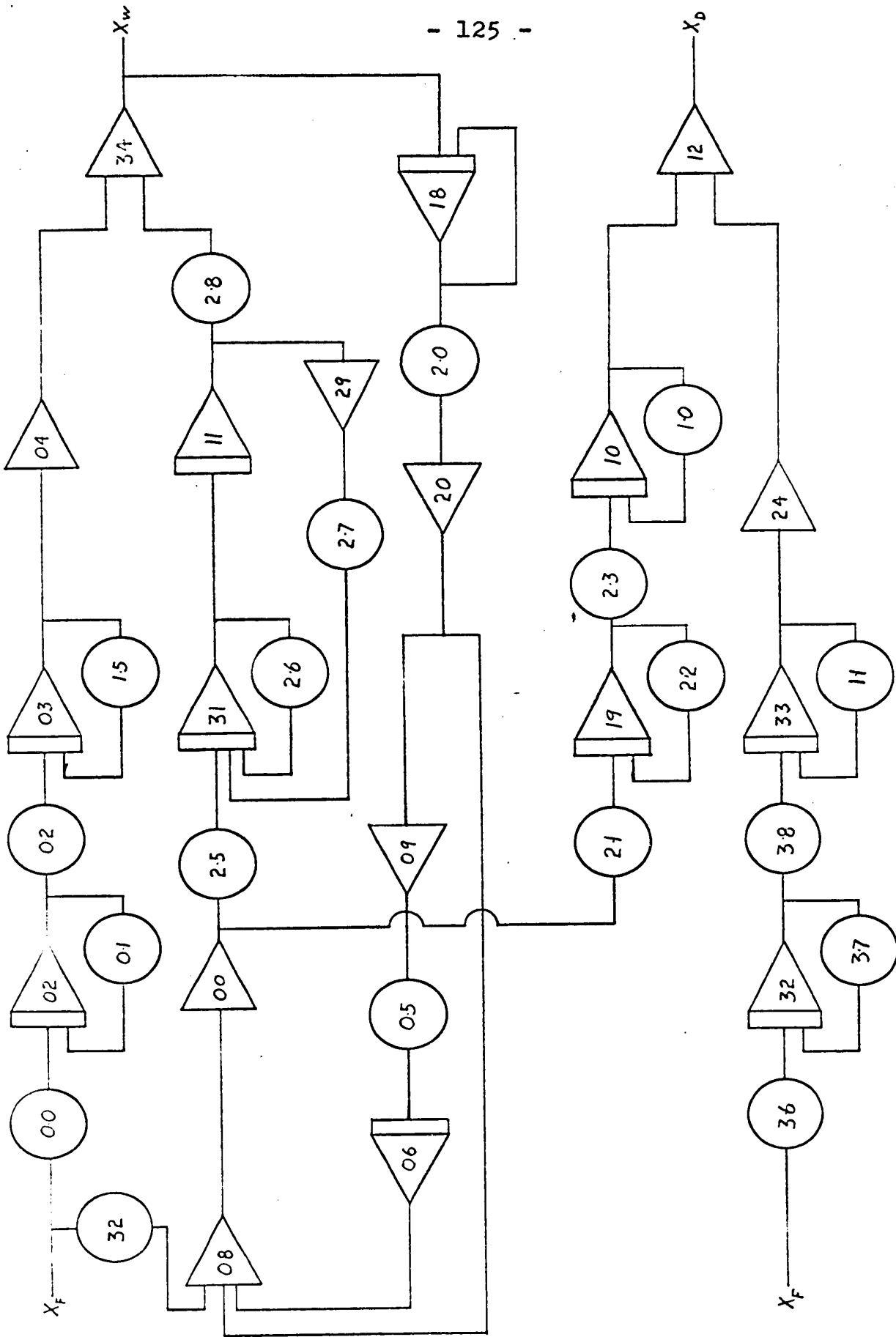

Figure 76. Analog computer circuit for control scheme 2-b

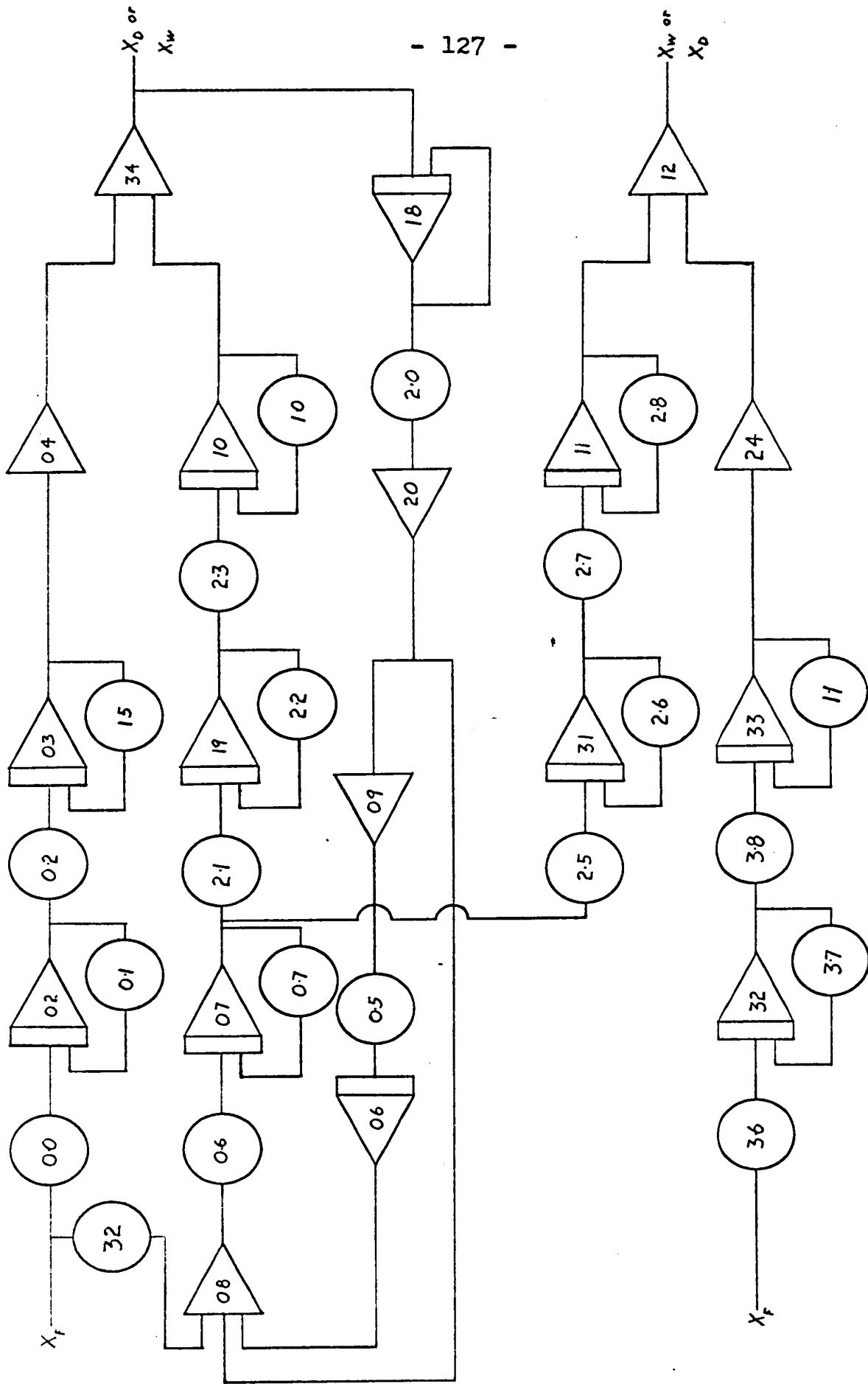

Figure 78. Analog computer circuit for control schemes 2-d and 2-e

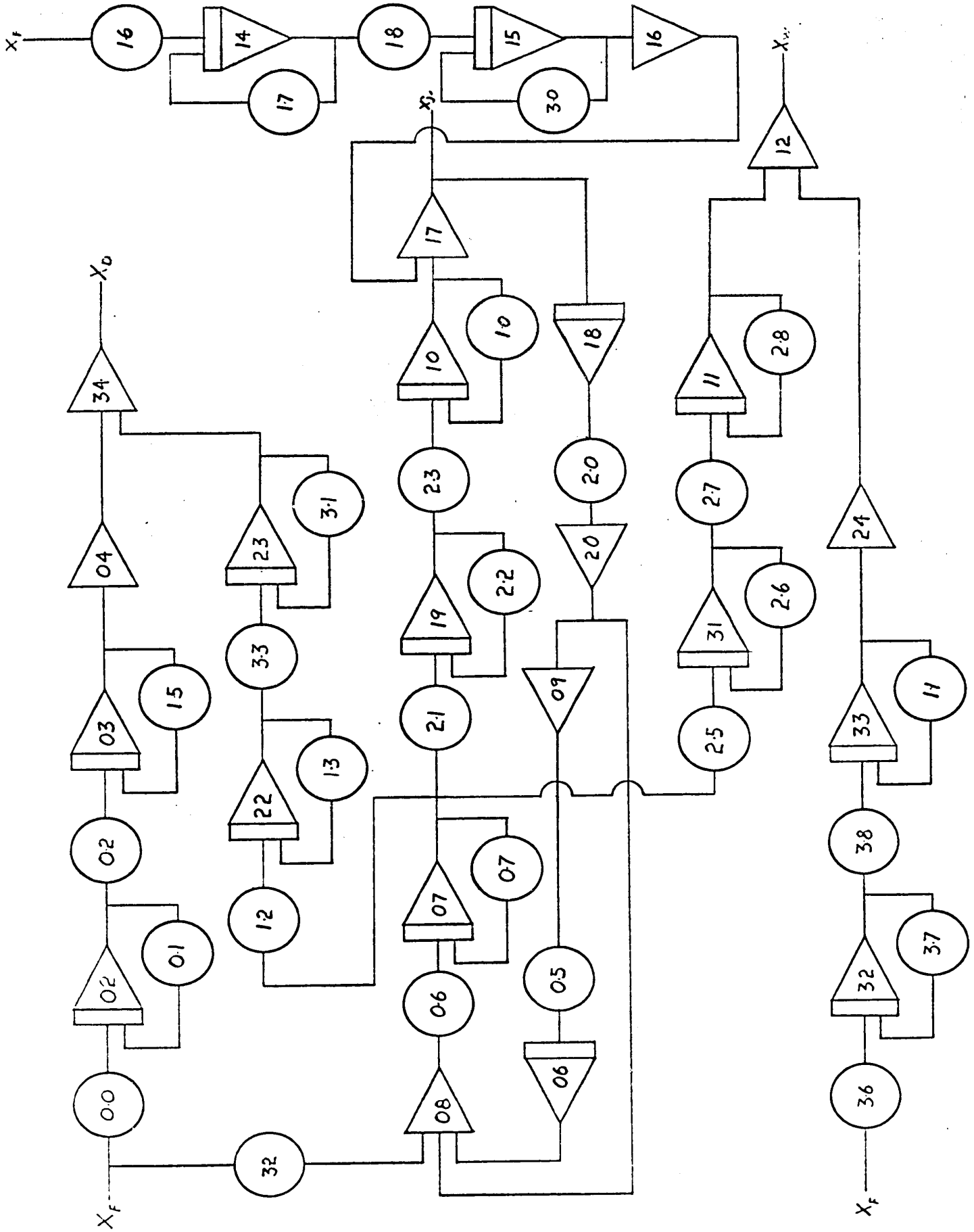

Figure 79. Analog computer circuit for control schemes 2-f, 2-h and 2-j

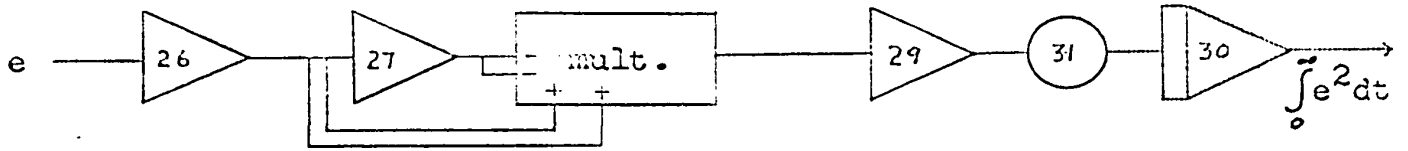

Figure 80. Error detecting circuit

POTENTIOMETER SHEET

Plate 9

Case	Pot No.	Coeff.	Value	Amplifier		Pot setting	Ref.
				No.	Gain		
1-c	00	.58/.15x10	.387	02	1	.387	10
2-c	01	1/.15	6.67	02	10	.667	
2-g	02	1/7.55	.132	03	1	.132	
and	05	1/T ₁		06		various	
2-i	10	1/6.65	.150	10	1	.150	
	11	1/8	.125	33	1	.125	
	12	.311/.1	3.11	22	10	.311	
	13	1/.1	10.00	22	10	1.00	
	15	1/7.55	.132	03	1	.132	
	16	1.17/.65x10	.180	14	1	.180	10
	17	1/.65	1.54	14	10	.154	
	18	1/7.8	.128	15	1	.128	
	20	K		20		various	
	21	.598/.27	2.21	19	10	.221	
	22	1/.27	3.70	19	10	.370	
	23	1/6.65	.150	10	1	.150	
	25	1/75	.013	31	1	.013	
	26	10/75	.133	31	1	.133	
	27	1/75	.013	31	1	.013	
	28	.258	.258	12	1	.258	
	30	1/7.8	.128	15	1	.128	
	31	1/8.2	.122	23	1	.122	
	33	1/8.2	.122	23	1	.122	
	36	.808/2.5x10	.032	32	1	.032	10
	37	1/2.5	.400	32	1	.400	

POTENTIOMETER SHEET

Plate 7

Case	Pot No.	Coeff.	Value	Amplifier		Pot setting	Ref.
				No.	Gain		
1-c,	00	.58/.15x10	.387	02	1	.387	10
2-c,	01	1/.15	6.67	02	10	.667	
2-g,	02	1/7.55	.132	03	1	.132	
and	05	1/ T ₁		06		various	
2-i	10	1/8	.125	10	1	.125	
	11	1/8	.125	33	1	.125	
	12	.311/.1	3.11	22	10	.311	
	13	1/.1	10.00	22	10	1.00	
	15	1/7.55	.132	03	1	.132	
	16	1.67/.6x10	.278	14	1	.278	10
	17	1/.6	1.67	14	10	.167	
	18	1/6.6	.152	15	1	.152	
	20	K		20		various	
	21	.909/.46	1.98	19	10	.198	
	22	1/.46	2.17	19	10	.217	
	23	1/8	.125	10	1	.125	
	25	1/75	.013	31	1	.013	
	26	10/75	.133	31	1	.133	
	27	1/75	.013	31	1	.013	
	28	.258	.258	12	1	.258	
	30	1/6.6	.152	15	1	.152	
	31	1/8.2	.122	23	1	.122	
	33	1/8.2	.122	23	1	.122	
	36	.808/2.5x10	.032	32	1	.032	10
	37	1/2.5	.400	32	1	.400	

POTENTIOMETER SHEET
Plate 3

Case	Pot No.	Coeff.	Value	Amplifier		Pot setting	Ref.
				No.	Gain		
1-c,	00	.58/.15x10	.387	02	1	.387	10
2-c,	01	1/.15	6.67	02	10	.667	
2-g,	02	1/7.55	.132	03	1	.132	
and	05	1/ T ₁		06		various	
2-i	10	1/8.25	.121	10	1	.121	
	11	1/8	.125	33	1	.125	
	12	.311/.1	3.11	22	10	.311	
	13	1/.1	10.00	22	10	1.00	
	15	1/7.55	.132	03	1	.132	
	16	1.94/7.9x10	.025	14	1	.025	10
	17	1/7.9	.127	14	1	.127	
	18	1/.1	10.00	15	10	1.00	
	20	K		20		various	
	21	1.015/.65	1.56	19	10	.156	
	22	1/.65	1.54	19	10	.154	
	23	1/8.25	.121	10	1	.121	
	25	1/75	.013	31	1	.013	
	26	10/75	.133	31	1	.133	
	27	1/75	.013	31	1	.013	
	28	.258	.258	12	1	.258	
	30	1/.1	10.00	15	10	1.00	
	31	1/8.2	.122	23	1	.122	
	33	1/8.2	.122	23	1	.122	
	36	.808/2.5x10	.032	32	1	.032	10
	37	1/2.5	.400	32	1	.400	

POTENTIOMETER SHEET

Plate 1

Case	Pot No.	Coeff.	Value	Amplifier		Pot setting	Ref.
				No.	Gain		
1-c,	00	.58/.15x10	.387	02	1	.387	10
2-c,	01	1/.15	6.67	02	10	.667	
2-g,	02	1/7.55	.132	03	1	.132	
and	05	1/ T ₁		06		various	
2-i	10	1/7.95	.126	10	1	.126	
	11	1/8	.125	33	1	.125	
	12	.311/.1	3.11	22	10	.311	
	13	1/.1	10.00	22	10	1.00	
	15	1/7.55	.132	03	1	.132	
	16	1.125/2.5x10	.045	14	1	.045	10
	17	1/2.5	.400	14	1	.400	
	18	1/9.2	.109	15	1	.109	
	20	K		20		various	
	21	.833/3.25	.256	19	1	.256	
	22	1/3.25	.308	19	1	.308	
	23	1/7.95	.126	10	1	.126	
	25	1/75	.013	31	1	.013	
	26	10/75	.133	31	1	.133	
	27	1/75	.013	31	1	.013	
	28	.258	.258	12	1	.258	
	30	1/9.2	.109	15	1	.109	
	31	1/8.2	.122	23	1	.122	
	33	1/6.2	.122	23	1	.122	
	36	.808/2.5x10	.032	32	1	.032	10
	37	1/2.5	.400	32	1	.400	

POTENTIOMETER SHEET

Plate 9

Case	Pot No.	Coeff.	Value	Amplifier		Pot setting	Ref.
				No.	Gain		
1-f	00	.58/.15x10	.387	02	1	.387	10
2-f	01	1/.15	6.67	02	10	.667	
2-h	02	1/7.55	.132	03	1	.132	
and	05	1/T ₁		06		various	
2-j	06	1/.5	2.00	07	10	.200	
	07	1/.5	2.00	07	10	.200	
	10	1/7.2	.139	10	1	.139	
	11	1/8	.125	33	1	.125	
	12	.273/4.5	.060	22	1	.060	
	13	1/4.5	.222	22	1	.222	
	15	1/7.55	.132	03	1	.132	
	16	1.17/.65x10	.180	14	1	.180	10
	17	1/.65	1.54	14	10	.154	
	18	1/7.8	.128	15	1	.128	
	20	K		20		various	
	21	.582/2.2	.265	19	1	.265	
	22	1/2.2	.455	19	1	.455	
	23	1/7.2	.139	10	1	.139	
	25	.627/6	.105	31	1	.105	
	26	1/6	.167	31	1	.167	
	27	1/11	.091	11	1	.091	
	28	1/11	.091	11	1	.091	
	30	1/7.8	.128	15	1	.128	
	31	1/5.5	.182	23	1	.182	
	33	1/5.5	.182	23	1	.182	

POTENTIOMETER SHEET

Plate 7

Case	Pot No.	Coeff.	Value	Amplifier		Pot setting	Ref.
				No.	Gain		
1-f	00	.58/.15x10	.387	02	1	.387	10
2-f	01	1/.15	6.67	02	10	.667	
2-h	02	1/7.55	.132	03	1	.132	
and	05	1/T _i		06		various	
2-j	06	1/.5	2.00	07	10	.200	
	07	1/.5	2.00	07	10	.200	
	10	1/7.95	.126	10	1	.126	
	11	1/8	.125	33	1	.125	
	12	.273/4.5	.060	22	1	.060	
	13	1/4.5	.222	22	1	.222	
	15	1/7.55	.132	03	1	.132	
	16	1.67/.6x10	.278	14	1	.278	10
	17	1/.6	1.67	14	10	.167	
	18	1/6.6	.152	15	1	.152	
	20	K		20		various	
	21	.800/.600	1.33	19	10	.133	
	22	1/.6	1.67	19	10	.167	
	23	1/7.95	.126	10	1	.126	
	25	.627/6	.105	31	1	.105	
	26	1/6	.167	31	1	.167	
	27	1/11	.091	11	1	.091	
	28	1/11	.091	11	1	.091	
	30	1/6.6	.152	15	1	.152	
	31	1/5.5	.182	23	1	.182	
	33	1/5.5	.182	23	1	.182	

POTENTIOMETER SHEET

Plate 3

Case	Pot No.	Coeff.	Value	Amplifier		Pot setting	Ref.
				No.	Gain		
1-f	00	$.58/.15 \times 10$.387	02	1	.387	10
2-f	01	$1/.15$	6.67	02	10	.667	
2-h	02	$1/7.55$.132	03	1	.132	
and	05	$1/T_1$		06		various	
2-j	06	$1/.5$	2.00	07	10	.200	
	07	$1/.5$	2.00	07	10	.200	
	10	$1/7.56$.132	10	1	.132	
	11	$1/8$.125	33	1	.125	
	12	$.273/4.5$.060	22	1	.060	
	13	$1/4.5$.222	22	1	.222	
	15	$1/7.55$.132	03	1	.132	
	16	$1.94/7.9 \times 10$.025	14	1	.025	10
	17	$1/7.9$.127	14	1	.127	
	18	$1/.1$	10.00	15	10	1.00	
	20	K		20		various	
	21	$1.22/1.14$	1.07	19	10	.107	
	22	$1/1.14$.877	19	1	.877	
	23	$1/7.56$.132	10	1	.132	
	25	$.627/6$.105	31	1	.105	
	26	$1/6$.167	31	1	.167	
	27	$1/11$.091	11	1	.091	
	28	$1/11$.091	11	1	.091	
	30	$1/.1$	10.00	15	10	1.00	
	31	$1/5.5$.182	23	1	.182	
	33	$1/5.5$.182	23	1	.182	

POTENTIOMETER SHEET
Plate 1

Case	Pot No.	Coeff.	Value	Amplifier		Pot setting	Ref.
				No.	Gain		
1-f	00	.58/.15x10	.387	02	1	.387	10
2-f	01	1/.15	6.67	02	10	.667	
2-h	02	1/7.55	.132	03	1	.132	
and	05	1/ T ₁		06		various	
2-j	06	1/.5	2.00	07	10	.200	
	07	1/.5	2.00	07	10	.200	
	10	1/7	.143	10	1	.143	
	11	1/8	.125	33	1	.125	
	12	.273/4.5	.060	22	1	.060	
	13	1/4.5	.222	22	1	.222	
	15	1/7.55	.132	03	1	.132	
	16	1.125/2.5x10	.045	14	1	.045	10
	17	1/2.5	.400	14	1	.400	
	18	1/9.2	.109	15	1	.109	
	20	K		20		various	
	21	1.30/4.5	.289	19	1	.289	
	22	1/4.5	.222	19	1	.222	
	23	1/7	.143	10	1	.143	
	25	.627/6	.105	31	1	.105	
	26	1/6	.167	31	1	.167	
	27	1/11	.091	11	1	.091	
	28	1/11	.091	11	1	.091	
	30	1/9.2	.109	15	1	.109	
	31	1/5.5	.182	23	1	.182	
	33	1/5.5	.182	23	1	.182	

