



uOttawa

L'Université canadienne
Canada's university

FACULTÉ DES ÉTUDES SUPÉRIEURES
ET POSTDOCTORALES



FACULTY OF GRADUATE AND
POSTDOCTORAL STUDIES

Hui Peng

AUTEUR DE LA THÈSE / AUTHOR OF THESIS

Ph.D. (Chemical Engineering)

GRADE / DEGREE

Department of Chemical Engineering

FACULTÉ, ÉCOLE, DÉPARTEMENT / FACULTY, SCHOOL, DEPARTMENT

Olly Wastewater Treatment Using Membrane Cascade Systems

TITRE DE LA THÈSE / TITLE OF THESIS

André Tremblay

DIRECTEUR (DIRECTRICE) DE LA THÈSE / THESIS SUPERVISOR

CO-DIRECTEUR (CO-DIRECTRICE) DE LA THÈSE / THESIS CO-SUPERVISOR

EXAMINATEURS (EXAMINATRICES) DE LA THÈSE / THESIS EXAMINERS

Xianshe Feng

Arturo Macchi

Christopher Lan

Poupak Mehrani

Gary W. Slater

Le Doyen de la Faculté des études supérieures et postdoctorales / Dean of the Faculty of Graduate and Postdoctoral Studies

OILY WASTEWATER TREATMENT USING MEMBRANE CASCADE SYSTEMS

By:

Hui Peng

A thesis submitted to the faculty of Graduate and Postdoctoral Studies
in partial fulfillment of the requirements for the degree of

DOCTOR OF PHILOSOPHY

in the Department of Chemical Engineering
Faculty of Engineering
University of Ottawa

© Hui Peng, Ottawa, Canada, 2008



Library and
Archives Canada

Published Heritage
Branch

395 Wellington Street
Ottawa ON K1A 0N4
Canada

Bibliothèque et
Archives Canada

Direction du
Patrimoine de l'édition

395, rue Wellington
Ottawa ON K1A 0N4
Canada

Your file *Votre référence*
ISBN: 978-0-494-50751-3
Our file *Notre référence*
ISBN: 978-0-494-50751-3

NOTICE:

The author has granted a non-exclusive license allowing Library and Archives Canada to reproduce, publish, archive, preserve, conserve, communicate to the public by telecommunication or on the Internet, loan, distribute and sell theses worldwide, for commercial or non-commercial purposes, in microform, paper, electronic and/or any other formats.

The author retains copyright ownership and moral rights in this thesis. Neither the thesis nor substantial extracts from it may be printed or otherwise reproduced without the author's permission.

AVIS:

L'auteur a accordé une licence non exclusive permettant à la Bibliothèque et Archives Canada de reproduire, publier, archiver, sauvegarder, conserver, transmettre au public par télécommunication ou par l'Internet, prêter, distribuer et vendre des thèses partout dans le monde, à des fins commerciales ou autres, sur support microforme, papier, électronique et/ou autres formats.

L'auteur conserve la propriété du droit d'auteur et des droits moraux qui protègent cette thèse. Ni la thèse ni des extraits substantiels de celle-ci ne doivent être imprimés ou autrement reproduits sans son autorisation.

In compliance with the Canadian Privacy Act some supporting forms may have been removed from this thesis.

Conformément à la loi canadienne sur la protection de la vie privée, quelques formulaires secondaires ont été enlevés de cette thèse.

While these forms may be included in the document page count, their removal does not represent any loss of content from the thesis.

Bien que ces formulaires aient inclus dans la pagination, il n'y aura aucun contenu manquant.

■*■
Canada

STATEMENTS OF CONTRIBUTIONS OF COLLABORATORS

I hereby declare that I am the sole author of this thesis. All articles in the thesis are co-authored with my thesis supervisor Dr. A. Y. Tremblay. One article is co-authored by Dr. Tremblay and Mr. D. Veinot from DRDC-Atlantic. All the experimental and analytical work related to these articles was performed by myself under the supervision and training received from Professor A. Y. Tremblay.

My supervisor, Dr. Tremblay, provided an excellent collaboration throughout this work with laboratory training, day-to-day supervision, discussions, inputs, supports and editorial comments for all of my written work. The quality of this research work has been improved significantly through his collaboration.

Signature

Date: June 6, 2008

Hui Peng

ABSTRACT

Ships produce a large amount of oily wastewaters such as bilge water which needs to be treated prior to being discharged. Bilge water is a very challenging wastewater to treat due to large variations in production rates and the complex nature of the wastes in solution. Ever increasing regulations are being imposed on the treatment and release of bilge water to the environment.

The objective of this study was to develop a membrane process to remove oil and grease from bilge water to a level where it could be discharged into sensitive environments. This work focused on five elements of study: 1) Evaluation of feasibility and performance of bilge water treatment using a pilot scale microfiltration/ultrafiltration (MF/UF) hybrid membrane system; 2) Development of a pilot scale membrane cascade for selective removal of oil to 0 ppm or a non-detectable level from bilge water while minimizing concentrate production; 3) Establishment of an analytical method to extract and analyze organic species at very low concentration levels for the analysis of oil and grease content found in bilge water and membrane permeate; 4) Investigation of environmentally friendly membrane cleaning methods; and 5) Study of filtration mechanism in the treatment of bilge water using ultrafiltration and microfiltration.

Pilot scale membrane cascade systems were designed and tested for the treatment of synthetic bilge water. Experimental results showed that the pretreatment of this oily wastewater using microfiltration, prior to ultrafiltration, is desirable as used oils and particulates can block the feed channels of UF spiral and hollow fiber modules. Backflushing is an effective technique to reduce fouling caused by “sticky” cakes in synthetic bilge water treatment using a microfiltration membrane. Membrane support structure was found to be critical in enhancing flux during backflushing. This work outlined the need for microfiltration membranes offering good particulate clearance to be used in backflushing coalescence applications. A pilot scale membrane hybrid system, consisting of a coalescing backflushed microfiltration membrane used as a

pretreatment and an ultrafiltration membrane as a final polishing step, was found to be very effective in this application, producing permeate with oil and grease content well below the allowable discharge limit (15 ppm) for coastal waters. Another membrane cascade system using tubular MF and UF membranes in a first stage and flat sheet UF membranes in a second stage was found to be able to produce water containing below detectable levels of hexane extractable material. Permeates of various molecular weight cut-off (MWCO) membranes from the cascade system were collected and analyzed using an extraction procedure followed by gas chromatography (GC). Analytical results showed that solid phase extraction using ENVI-18 sorbent retained much of the organic matter found in the bilge water and could not preserve the molecular weight distribution in the oil mixture used to prepare synthetic bilge water. n-Hexane liquid-liquid extraction technique was found to be able to preserve the molecular weight distribution of diesel and lubricating oils separated by ultrafiltration. The effect of membrane MWCO in separation of oil and grease was also studied in this work. Environmentally friendly physical membrane cleaning methods, such as backflushing with hot water or steam followed by pressurized air, were found effective in regenerating membrane flux for large pore KOCH carbon membranes in the treatment of synthetic bilge water using a MF/UF hybrid system. The beneficial effects for steam cleaning were found to be evident. Optimal cycle times between physical cleanings were determined. Filtration mechanisms in the treatment of synthetic bilge water were studied using four classical filtration models and a combined model.

Experimental results of the research conducted in this study suggested that it is possible to achieve the target of removing oil from bilge water to 0 ppm or non-detectable levels through the proper design of the membrane system, selection of appropriate membranes, determination of optimal operating parameters, and assessment of membrane performance.

RÉSUMÉ

Les navires produisent une grande quantité d'eaux usagées huileuses telle que l'eau de cale qui doit-être traitée avant d'être déchargée. Les eaux de cale sont très difficiles à décontaminer a bord d'un navire en raison des grandes variations dans leur composition et leur taux de production. Une réglementation de plus en plus étroite est imposée au traitement et au vidangeage de ces eaux. L'objectif de cette étude était de développer un procédé membranaire pour enlever les huiles et graisses de l'eau de cale à un niveau où elles peuvent être déchargées dans des environnements sensibles. Ce travail porte sur cinq éléments d'études: 1) l'évaluation de la faisabilité du traitement de l'eau de cale en utilisant un système pilote de membranes micro et ultrafiltrantes (MF/UF); 2) développement d'une cascade de membranes à l'échelle pilote pour la rétention sélective des huiles et graisses tout en réduisant au minimum la production de concentrat; 3) l'établissement d'une méthode analytique pour extraire et analyser les huiles et graisses à très basse concentration; 4) recherche sur des méthodes de régénération des membranes qui minimisent les déchets; et 5) l'étude du mécanisme de filtration dans le traitement de l'eau de cale en UF et MF.

Les résultats expérimentaux ont démontrés que le prétraitement de cette eau usagée huileuse en utilisant la microfiltration, avant l'ultrafiltration, est souhaitable car les huiles usées et les substances particulières peuvent bloquer les canaux d'alimentation d'un module à fibres creuses. Le renflouement est une technique efficace pour réduire l'encrassement provoqué par l'entartrement de particules à la surface et dans les pores des membranes. Le support de la couche sélective d'une membrane microfiltrante joue un rôle important dans le dégagement de particules pendant le renflouement de la membrane. Les résultats de ce travail indiquent que des membranes de microfiltration offrant un bon dégagement particulaire doivent-être employées dans cette application.

Un système hybride, se composant d'un prétraitement avec une membrane microfiltrante renflouée à intervalles régulières suivies d'une membrane ultrafiltrante s'est avérée très efficace dans cette application. Le contenu en huiles et graisses de l'eau finale étaient

sous la limite permise de décharge (15 ppm) pour les eaux côtières. Un second système de cascade de membranes MF/UF tubulaires suivie de membranes UF planes c'est avéré capable produire une l'eau contenant des huiles et graisses sous le seuil de détection. Des membranes ayant différents seuils de coupure (MWCO) ont été utilisées dans la seconde étape du traitement. Les perméats de cette membrane ont été analysés en utilisant un procédé d'extraction suivi d'une chromatographie en phase gazeuse (GC).

Les épreuves initiales employant une technique d'extraction en phase solide (SPE) n'ont pas réussies car les huiles et graisses ne pouvaient pas être éluées d'un sorbant couramment utilisé en l'analyse environnementale (ENVI-18). La technique d'extraction liquide-liquide avec de l'hexane s'est avérée la meilleure pour préserver la distribution de poids moléculaire du diesel et des huiles utilisées dans le mélange synthétique d'eau de cale.

L'effet du seuil de coupure de la membrane (MWCO) dans la séparation des huiles et graisses a été étudié. Des méthodes de nettoyage physiques telles que le renflouement (backflushing) avec de l'eau chaude ou de la vapeur suivie d'air pressurisé, se sont avérées efficaces pour régénérer les membranes microfiltrantes exposées directement à l'eau de cale. Des mécanismes de filtration ont été étudiés en utilisant quatre modèles classiques de filtration et un modèle combiné. Le modèle de filtration combiné offre la meilleure explication des mécanismes de filtration.

Cette étude a démontrée qu'il est possible de réaliser la cible d'enlever l'huile de l'eau de cale à des niveaux non détectables par une cascade MF/UF tout en minimisant la production de concentrat qui doit être gardé a bord d'un navire jusqu'a la prochaine escale.

ACKNOWLEDGEMENTS

I wish to express my sincere appreciation and deep gratitude to my supervisor, Dr. André Y. Tremblay, for his guidance in the completion of this thesis. I thank him for bringing me into the field of academic research; for teaching me laboratory skills; for assisting me to improve my communication skills; for helping me to develop professionalism with his diligent work, passion, enthusiasm, endless energy, comprehensive thinking and rigorous attitude in academic research; for guiding me throughout this work with generosity and patience; for devoting his valuable time for me on day-to-day supervision, inputs, beneficial discussions and valuable comments; and for helping me on my career development. Without his patience and endless help, this study would not be possible. I will always remember and appreciate his generous assistance.

I would like to thank Mr. Dwight Vienot of the Defence Research & Development Canada-Atlantic (DRDC-Atlantic). Mr. Vienot's involvement in this project ensured that I received financial support to complete this program.

I am grateful to the Department's administrative and support staff for their help. In particular, I would like to thank the technicians at our department, Mr. Louis Tremblay, Mr. Gérard Nina and Mr. Franco Zirolto, for their assistance in the lab.

I would also like to thank all the graduate students of our department with whom I have attended classes, worked, shared ideas and had fun together.

Finally, I wish to thank my wife, Huaiwen Chen, and our daughters, Xiaoshan Peng and Eileen Peng, for their love, support, encouragement and understanding throughout my studies at the University of Ottawa.

NOMENCLATURE

A	surface area of the membrane (m^2)
C_b	bulk concentration (kg/m^3)
d	membrane pore diameter (μm)
J_0	initial filtrate flux through the clean membrane ($L/m^2/h$)
J_V	filtrate flux ($L/m^2/h$)
K_1	constant in combined model (h^{-1})
K_2	constant in combined model (h^{-1})
K_3	constant in combined model (h^{-1})
K_{block}	constant in complete blocking model (h^{-1})
K_{cake}	constant in cake filtration model (h^{-1})
$K_{constriction}$	constant in pore constriction model (h^{-1})
K_{inter}	constant in intermediate blocking model (h^{-1})
N_0	initial pore density (kg/m^3)
Δp	trans-membrane pressure (Pa)
R_m	hydraulic resistance of the membrane (m^{-1})
R_{inter}	filter resistance in intermediate blocking model (m^{-1})
r_p	pore radius (m)
t	filtration time (h)
V	filtration volume (m^3)
α_{block}	pore blockage efficiency
α_{cake}	specific cake resistance (m/kg)
σ_{inter}	blocked area per unit filtrate volume (m^2/m^3)
α_{pore}	pore constriction efficiency
δ_m	cake thickness (m)
γ	surface tension (dynes/cm)

θ	liquid-solid contact angle (°)
μ	filtrate Newtonian dynamic viscosity (Ns/m ²)

ACRONYMS

APHA	= American Public Health Association
AWWA	= American Water Works Association
BF	= Backflushing
BSA	= Bovine Serum Albumin
CA	= Cellulose Acetate
DCM	= Methylene Chloride
DLS	= Dispersive Light Scattering
DND	= (Canadian) Department of National Defence
DRDC	= Defence Research and Development Canada
DREA	= Defence Research Establishment Atlantic
EPA	= Environmental Protection Agency
FID	= Flame Ionization Detector
GC	= Gas Chromatography
HP	= Horsepower
HEM	= Hexane Extractable Materials
ID	= Inside Diameter
IMO	= International Maritime Organization
IR	= Infrared
ISO	= International Organization for Standardization
MD	= Membrane Distillation
MF	= Microfiltration
MWCO	= Molecular Weight Cut-Off
NATO	= North Atlantic Treaty Organisation
NF	= Nanofiltration
OD	= Outside Diameter
O & G	= Oil and Grease
OWS	= Oily Water Separator
PAC	= Powdered Activated Carbon
PAH	= Polycyclic Aromatic Hydrocarbon

PAN	= Polyacrylonitrile
PES	= Poly (ether sulfones)
PS	= Polystyrene
PVC	= Polyvinyl Chloride
PVDF	= Polyvinylidene Fluoride
ppm	= parts per million
RO	= Reverse Osmosis
RTD	= Resistance Temperature Detector
SPE	= Solid Phase Extraction
SPME	= Solid-phase Microextraction
SW	= Seawater
TF	= Thin Film
TMP	= Trans-membrane Pressure
TPH	= Total Petroleum Hydrocarbons
UF	= Ultrafiltration
WEF	= Water Environment Federation

TABLE OF CONTENTS

STATEMENTS OF CONTRIBUTIONS OF COLLABORATION	ii
ABSTRACT	iii
RÉSUMÉ	v
ACKNOWLEDGEMENTS	vii
NOMENCLATURE	viii
ACRONYMS	x
TABLE OF CONTENTS	xii
LIST OF TABLES	xviii
LIST OF FIGURES	xx
CHAPTER I	
INTRODUCTION	1
1. Background	1
2. Problem Definition	2
3. Thesis and Objectives	3
4. New Knowledge Gained from this Study	5
REFERENCES	11
CHAPTER II	
Paper 1: The use of backflushed coalescing microfiltration as a pretreatment for the ultrafiltration of bilge water	17
ABSTRACT	17
1. INTRODUCTION	18
2. EXPERIMENTAL	21
2.1 Bilge water preparation	21
2.2 Membranes	22
2.2.1 Carbon membrane	22
2.2.2 Ceramic membrane	22
2.2.3 Polymeric membrane	23

2.3 Experimental set-up	23
2.4 Experimental procedure and analytical methods.....	25
3. RESULTS AND DISCUSSION.....	26
3.1 Effect of pore size.....	26
3.1.1 KOCH carbon tubular membranes	26
3.1.2 TAMI ceramic tubular membranes	29
3.2 Effect of backflushing.....	31
3.2.1 Backflushing vs. no backflushing for KOCH carbon membranes	31
3.2.2 Effect of backflushing frequency.....	32
3.2.3 Effect of trans-membrane pressure on different types of membranes	33
3.3 Oil and grease content of the permeate	36
4. CONCLUSIONS.....	38
ACKNOWLEDGEMENTS.....	38
REFERENCES.....	38

CHAPTER III

Paper 2: The selective removal of oil from wastewaters while minimizing concentrate production using a membrane cascade	42
ABSTRACT.....	42
1. INTRODUCTION.....	43
1.1 Problem definition.....	43
1.2 Membrane processes for oily wastewater treatment.....	43
1.3 Membrane hybrid system	43
1.4 Bilge water treatment.....	44
1.5 Objective of this study.....	45
2. EXPERIMENTAL.....	46
2.1 Experimental set-up.....	46
2.2 Membrane.....	48
2.2.1 Tubular membranes.....	48

2.2.2 Flat sheet membranes.....	49
2.3 Oily brine preparation	50
2.4 Analytical.....	51
2.5 Experimental procedure.....	51
3. RESULTS AND DISCUSSION	52
3.1 Membrane permeation tests	52
3.1.1 UF tests.....	52
3.1.2 NF tests.....	55
3.2 Separation of oil and grease.....	57
3.3 Particle size measurements.....	58
3.3.1 Determination of particle size in synthetic bilge water.....	58
3.3.2 Determination of particle size in loop 1 and loop 2.....	59
4. CONCLUSIONS	61
ACKNOWLEDGEMENTS	61
REFERENCES.....	62

CHAPTER IV

Paper 3: The analysis of treated bilge water from a combined MF/UF hybrid membrane system.....	66
ABSTRACT.....	66
1. INTRODUCTION.....	67
2. EXPERIMENTAL.....	69
2.1 Bilge water preparation.....	69
2.2 Sample collection	70
2.3 Solid phase extraction (SPE)	70
2.4 n-Hexane liquid-liquid extraction.....	70
2.5 Gas chromatography (GC).....	71
3. RESULTS AND DISCUSSION	72
3.1 Validation of analytical methods.....	72
3.1.1 SPE.....	72
3.1.2 n-Hexane liquid-liquid extraction.....	73

3.2 Oil and grease determination	73
3.2.1 Chromatogram of standard mixture	73
3.2.2 Chromatograms of oil mixture in bilge water	75
3.3 Effect of surfactant concentration in extraction	77
3.4 Determination of oil and grease in treated synthetic bilge water	78
3.4.1 Oil and grease concentration in loop 1 feed	79
3.4.2 Oil and grease concentration in loop 1 permeate	79
3.4.3 Oil and grease concentration in loop 2 permeate	80
3.5 Separation of oil and grease	81
4. CONCLUSIONS	82
ACKNOWLEDGEMENTS	83
REFERENCES	83

CHAPTER V

Paper 4: Determination of oil and grease in treated synthetic bilge water

produced from a membrane cascade system	87
ABSTRACT	87
1. INTRODUCTION	88
2. EXPERIMENTAL	90
2.1 Bilge water preparation	90
2.2 Sample collection	90
2.3 n-Hexane liquid-liquid extraction	91
2.4 Gas chromatography (GC)	91
3. RESULTS AND DISCUSSION	91
3.1 Oil and grease concentration in loop 1 feed and permeate	91
3.2 Oil and grease concentration in UF permeates	92
3.3 Separation of oil and grease	95
3.4 Aliphatic vs. aromatic content of the permeates	96
4. CONCLUSIONS	98
ACKNOWLEDGEMENTS	99
REFERENCES	99

CHAPTER VI

Paper 5: Waste minimization in treating oily wastewaters by microfiltration	102
ABSTRACT	102
1. INTRODUCTION	103
2. EXPERIMENTAL	105
2.1 Oily wastewater (bilge water) preparation	105
2.2 Membranes	106
2.2.1 Carbon MF membrane	106
2.2.2 Polymeric UF membrane	106
2.3 Experimental set-up	107
2.4 Experimental procedure and analytical methods	108
3. RESULTS AND DISCUSSION	110
3.1 Chemical cleaning	110
3.2 Air, hot water and steam cleaning	111
3.3 Coalescing of oil particles in microfiltration membranes	115
3.4 Modeling of cleaning runs	116
3.4.1 Membrane fouling models	116
3.4.2 Effect of cleaning temperature	118
3.4.3 Hot water cleaning with and without backflushing	120
3.4.4 Optimal cleaning times	121
4. CONCLUSIONS	123
5. LIST OF SYMBOLS	123
ACKNOWLEDGEMENTS	124
REFERENCES	124

CHAPTER VII

Paper 6: The study of filtration mechanism in the treatment of bilge water using ultrafiltration and microfiltration	129
ABSTRACT	129
1. INTRODUCTION	129
2. THEORY	131

3. EXPERIMENTAL	133
3.1 Bilge water preparation	133
3.2 Membranes	134
3.3 Experimental set-up	134
3.4 Experimental procedure and analytical methods	136
4. RESULTS AND DISCUSSION	137
4.1 Summary of experimental results	137
4.2 Modeling of filtration mechanisms	139
5. CONCLUSIONS	144
6. LIST OF SYMBOLS	144
ACKNOWLEDGEMENTS	145
REFERENCES	145
CHAPTER VIII	
DISSUSSION	148
REFERENCES	155
CHAPTER IX	
CONCLUSIONS	157
CHAPTER X	
RECOMMENDATIONS	159

LIST OF TABLES

CHAPTER II

Table 1 KOCH Carbon Membrane Characteristics.....	22
Table 2 TAMI Céram Membrane Characteristics.....	23
Table 3 KOCH XM50 Hollow Fiber Membrane Characteristics	23
Table 4 Oil and grease recovery and rejection of the KOCH Carbon1.4 micron membrane in a MF/UF hybrid system. Base case is for the UF membrane exposed directly to the feed solution containing 4 g/L of O & G	37

CHAPTER III

Table 1 TAMI Céram Membrane Characteristics.....	49
Table 2 Characteristics of the flat sheet membranes.....	50

CHAPTER IV

Table 1 Characteristics of standard mixtures and GC injection results.....	74
Table 2 Membrane performance for bilge water purification in a cascade system.....	82

CHAPTER V

Table 1 Membrane performance for bilge water purification in a cascade system.....	95
Table 2 Example of typical PAHs found in composite Diesel Fuel #2.....	96
Table 3 Properties of lower molecular weight C10 to C16 alkanes found in diesel	97

CHAPTER VI

Table 1 KOCH Carbo-cor Membrane Characteristics.....	106
Table 2 KOCH XM50 Hollow Fiber Membrane Characteristics.....	107
Table 3 Five different membrane filtration models.....	117
Table 4 Modeling results for the KOCH 1.4 micron membranes.....	119
Table 5 Optimal cleaning time with different cleaning methods.....	122

CHAPTER VII

Table 1 Five different membrane filtration models.....	132
Table 2 TAMI Ceramic Membrane Characteristics.....	134
Table 3 Operating conditions and sum of squares of residuals for the analysis of various filtration mechanisms described in Table 1	138
Table 4 Different filtration constants for the analysis of various filtration mechanisms described in Table 1	138

LIST OF FIGURES

CHAPTER II

Figure 1 Schematic diagram of the MF/UF hybrid system.....	25
Figure 2 Plot of permeate flux vs. time for various KOCH carbon tubular membranes (Operating pressure 35 psig, 25°C. The 0.1 and 0.2 micron membranes were cleaned after the first 24 hours of operation).....	27
Figure 3 Plot of permeate flux vs. time for the KOCH carbon 0.5 micron membrane (Operating pressure 35 psig, 25°C. Backflushing up to 48 hours then no backflushing.).....	28
Figure 4 Particle size distribution for used oil. DLS measurements. Peaks for the smaller radii are at 0.07, 0.089 and 0.1 microns [17].....	29
Figure 5 Plot of steady-state permeate flux vs. membrane pore size for the various TAMI ceramic and KOCH carbon membranes (TMP=14.67 psig, 35°C).....	30
Figure 6 Permeate production/m ² /day vs. membrane pore diameter. Backflushing runs were performed using the MF/UF hybrid system (Backflush using UF permeate, effective backflushing TMP=2.41 barg (35 psig), for 3 sec/ 5 min, based on newly prepared bilge water containing 4 g/l of O & G + detergents).....	31
Figure 7 Plot of flux vs. time for the KOCH carbon 1.4 micron membrane with different backflushing time (TMP=5 psig, 35°C, backflushing pressure 35 psig).....	33
Figure 8 Plot of flux vs. time for the single tube carbon 1.4 micron membrane and the multilumen ceramic 1.4 micron membrane for different TMPs (No cleaning between pressure adjustments, both membranes were backflushed for 3 seconds out of a 5 minutes cycle at 35 psig, 35°C).....	34
Figure 9 Different support structure of the TAMI ceramic and KOCH carbon Membranes.....	35
Figure 10 Exterior of the multilumen TAMI ceramic membrane at the end of this study.....	36

Figure 11 Plot of O & G concentration vs. membrane pore radius for the TAMI membranes.....	37
---------------------------------------------------------------------------------------------------	----

CHAPTER III

Figure 1 Flow diagram of the two-loop membrane cascade system.....	48
Figure 2 Plot of permeate flux vs. time for the MW and EW membranes (35 °C, operating pressure 30 psig).....	53
Figure 3 Plot of permeate flux vs. time for the JW and CQ membranes (35 °C, operating pressure 50 psig).....	54
Figure 4 Plot of permeate flux vs. time for the PT, GM, GK, and GH membranes (35 °C, operating pressure 80 psig).....	54
Figure 5 Steady-state permeate flux vs. MWCO for the UF and NF membranes (35 °C).....	56
Figure 6 Osmotic pressure (psi) of mono and divalent salts in a solution of 50:50 fresh and synthetic seawater (Synthetic seawater was prepared according to ASTM D1141-90: “Standard Specification for Substitute Ocean Water” [18]).....	57
Figure 7 Plot of retention of hexane extractable organics vs. membrane MWCO.....	58
Figure 8 Overlay plot of the particle size distribution in seawater, oily seawater and oily seawater containing surfactant (mixtures a), b) and c) as described above).....	59
Figure 9 Overlay plot of the particle size distribution in loop 1 permeate and loop 2 retentate (loop 1 membrane: 300 kD TAMI, loop 2 membranes: GH and GK).....	60
Figure 10 Overlay plot of the particle size distribution in loop 1 permeate and loop 2 retentate (loop 1 membrane: 300 kD TAMI, loop 2 membranes: PT and GM).....	60

CHAPTER IV

Figure 1 Overlaid plot of two injections by GC/FID (Perkin Elmer AutoSystem, solid line is diesel oil, dotted line is lubricating oil).....	75
----------------------------------------------------------------------------------------------------------------------------------------------------	----

Figure 2 Analysis of oil mixture found in synthetic bilge water. Four (4) microlitre injection of a 4 mg oil mixture / mL of hexane.....	76
Figure 3 Analysis of oils extracted using 25 mL of hexane from 0.1 gr oil mixture found in synthetic bilge water in 2 L of seawater.....	77
Figure 4 Plot of peak area vs. surfactant concentration for the C10 (n-decane).....	78
Figure 5 GC-FID chromatogram of the hexane soluble material in loop 1 feed (before the 300 kD MWCO membrane; 50 mL of feed solution extracted using hexane evaporated then diluted with 2 mL of hexane, 4 microlitre injection volume).....	79
Figure 6 GC-FID chromatogram of the hexane soluble material in loop 1 permeate (after the 300 kD MWCO membrane).....	80
Figure 7 GC-FID chromatogram of the hexane soluble material in loop 2 permeate (after the 2 kD MWCO membrane).....	81

CHAPTER V

Figure 1 GC-FID chromatograms of the hexane soluble material in loop 1 feed and permeate (before and after the 300 kD MWCO membrane)	92
Figure 2 GC-FID chromatograms of the hexane soluble material in loop 1 (300 kD MWCO) and loop 2 permeates for membranes in the 5 kD to 100 kD MWCO range	93
Figure 3 GC-FID chromatograms of the hexane soluble material in loop 1 (300 kD MWCO) and loop 2 permeates for membranes in the 1 kD to 5 kD MWCO range	94
Figure 4 Particle size distribution in treated synthetic bilge water (DLS).....	98

CHAPTER VI

Figure 1 Schematic diagram of the MF/UF hybrid system.....	108
Figure 2 Plot of Flux vs. Time for the KOCH carbon 0.1 micron membrane after cleaning (TMP=1.72 barg (25 psig), 25°C).....	111

Figure 3 Plot of the measured permeate flux vs. time in days (Measured permeate flux is for bilge water containing 6 to 8 g/L of Oil and Grease + detergent; Backflushing was performed using UF permeate except when no UF is specified).....	114
Figure 4 Fouling of membrane in this study. a) Standard filter cake; b) Cake and coalesced oils inside the pores.....	115
Figure 5 Flux vs. Time for the KOCH 1.4 micron membranes after cleaning at different temperatures.....	118
Figure 6 Plot of permeate flux vs. time for the KOCH 1.4 micron membrane after steam cleaning.....	119
Figure 7 Permeate flux vs. Time for the KOCH 1.4 micron membrane (T=100 °C). The combined model was used to fit to the above data	121
Figure 8 Effective flux vs. Time between cleanings for the KOCH 1.4 micron membranes for a 20 minutes physical cleaning time and a 2 hours chemical cleaning time.....	122

CHAPTER VII

Figure 1 Schematic diagram of the pilot-scale membrane system.....	135
Figure 2 Plot of flux vs. time for the TAMI 50 kD membrane (TMP=15psig, 35°C, see Table 3 for sum of the square of residuals and Table 4 for filtration constants)	139
Figure 3 Plot of flux vs. time for the TAMI 150 kD membrane (TMP=7.34psig, 35°C, see Table 3 for sum of the square of residuals and Table 4 for filtration constants)	140
Figure 4 Plot of flux vs. time for the TAMI 300 kD membrane (TMP=7.34psig, 35°C, see Table 3 for sum of the square of residuals and Table 4 for filtration constants)	140
Figure 5 Plot of flux vs. time for the TAMI 70 nm membrane (TMP=15psig, 35°C, see Table 3 for sum of the square of residuals and Table 4 for filtration constants)	141

- Figure 6** Plot of flux vs. time for the TAMI 0.8 micron membrane (TMP=5psig, 35°C, see Table 3 for sum of the square of residuals and Table 4 for filtration constants)141
- Figure 7** Plot of flux vs. time for the TAMI 1.4 micron membrane (TMP=5psig, 35°C, see Table 3 for sum of the square of residuals and Table 4 for filtration constants)142
- Figure 8** Particle size distribution for used oil. DLS measurements. Peaks for the smaller radii are at 0.07, 0.089 and 0.1 microns [17]143

CHAPTER I

INTRODUCTION

1. Background

One of marine industry's primary environmental concern is the overboard discharge of ship pollutants into the natural environments, which creates a major ecological problem throughout the world. Bilge water is a major source of ship pollutants, accounts for about 20% of the total amount of several million tons of oily wastewaters that are annually discharged into the sea from the vessels (Tomaszewska et al., 2005). Bilge water is a wastewater that accumulates in the lowest internal part of a ship, composed of a complex "cocktail" of mechanical and chemical emulsions, and contaminants. Bilge oil characteristics and generation rate depend on the type of ship and its operation (Bhattacharyya et al., 1979). Typical contaminants may include fuels, oils, detergents, greases, solvents, rusts, paints, insulation material and a wide variety of other substances. The concentration of oil and grease in bilge water ranges from 200 to 2,000 parts per million (ppm) (Alper, 2003). This oily wastewater differs from those found in the petrochemical and automotive industries or in domestic sewage operations. Bilge water is a mixture of fresh and seawater (SW). It contains a variety of salts and is very corrosive. Therefore, it is more appropriate to refer to bilge water as an oily brine. The varied nature and composition of bilge water poses a more difficult separation problem than the treatment of conventional oil in water emulsions.

In recent years, considerable attention has been focused on discharge of oily wastewater from ships. The International Maritime Organization (IMO) has been the leader in developing discharge regulations for bilge water and other ship-generated pollution (IMO, 2002). The discharge limit for oily bilge water within coastal waters is recognized internationally as 15 ppm while within localities, more stringent limits exist. Currently, in Canada, overboard discharge regulations limit the total content of oil and grease to be no greater than 100 ppm oil beyond 12 nautical miles off shore, 15 ppm oil

within 12 nautical miles off shore, 5 ppm oil within coastal waters, and 0 ppm oil in the Arctic and Pacific coast (Transport Canada, 2001).

Recent natural resource discoveries have caused increased exploration and industrial activity in the Canadian Arctic. In addition to this, new shipping routes are being examined in light of the accelerated melting of the polar icecap. The arctic is a sensitive environment where the biodegradation of organics is very slow due to cold climactic conditions and low sunlight. These new transportation and exploration activities have brought new sources of pollution in the form of spent fuels and greases which have entered in contact with water and have been leached into the environment. Bilge water released from ships operating in arctic waters must meet very stringent requirements prior to being discharged. The inevitable pervasive use of large machinery in this sensitive environment will create wastewaters containing fuels and greases. Conventional best available technology might not be sufficient to protect this sensitive environment. There is a need to develop better technology to treat wastewaters containing oils and greases for release in this sensitive environment.

2. Problem Definition

Historically, oily bilge water has been treated using Oily Water Separators (OWS). OWS systems are based on gravity separation, size separation, chemical affinity separation and flocculation. Membrane technology in wastewater treatment has moved forward quickly in recent years because of the development of new technologies to manufacture membranes. Membrane ultrafiltration (UF) has been identified as a key technology in the treatment of oily wastewaters (Zeman and Zydney, 1996). UF membranes are currently employed in industry to treat large process oily waste streams (Gryta et al., 2001). Microfiltration (MF) membranes with a pore size of 0.1 μm were found to be effective in the separation of oily wastewaters and the recovery of surfactant in the feed solution (Cheryan and Rajagopalan, 1998). Membrane technologies provide a barrier between the wastewater and effluent, which eliminates the possibility of accidental spills. Membrane fouling is present in most membrane

applications and needs to be reduced. Another important issue is the application of an appropriate type of membrane in treating this specific oily wastewater. In practice, operating costs can be reduced and the overall efficacy of membrane based oily water separators improved by proper membrane selection, system design and maintenance.

Developing an OWS system to meet the levels required for discharge in sensitive environments is very challenging. Many issues must be considered in the ship-born application of membrane based OWS such as; the proper treatment of the oily brine before discharge, the substantial volume reductions needed, the complexity of the technology, labour associated with the operation of the system due to filter changes and cleaning, and system automation to simplify its operation. The presence of a high level of divalent salts in oily wastewaters containing seawater (such as bilge water) greatly complicates the removal of oil and grease down to ppm levels by membrane technologies. The conventional approach to solve this problem would be to use a reverse osmosis (RO) membrane to remove all dissolved and suspended material. However, the high osmotic pressure of seawater eliminates this as a feasible approach.

3. Thesis and Objectives

Is it possible to treat bilge water, a harsh oily wastewater containing suspended oil droplets and particles, using a membrane process and to remove oil and grease to non-detectable levels where it could be discharged into sensitive environments?

This study focused on evaluating the feasibility of bilge water treatment using a membrane cascade. Several activities were performed in the course of this study, such as; membrane system design, membrane selection, determination of optimum operating parameters, concentrate minimization, development of analytical methods for oil and grease determination, investigation of environmentally friendly cleaning methods, and study of filtration mechanisms.

This objective was accomplished by performing studies on the following five elements:

1) Evaluation of the feasibility and performance of bilge water treatment to meet coastal discharge limit (15 ppm) using a pilot scale microfiltration/ultrafiltration (MF/UF) hybrid membrane system. This study investigated membrane system design, membrane selection, optimal operating parameters and the concept of backflushed coalescing microfiltration for the pre-treatment of oily wastewaters prior to ultrafiltration. This work was an important contribution to this thesis, which helped us to gain valuable knowledge and experience in membrane system design and testing for the treatment of bilge water. This study enabled us to develop a second membrane system to conduct further research in this thesis.

2) Development of a pilot scale membrane cascade for selective removal of oil to 0 ppm or a non-detectable level from bilge water while minimizing concentrate production. Based on our previous research findings in part 1 above, we developed a second membrane cascade and evaluated the system performance for the treatment of bilge water. The important contributions of this study to the thesis include the concept of developing a membrane cascade system for the selective removal of oil to 0 ppm or non-detectable levels from bilge water while minimizing the production of brine retentate waters that must be stored onboard a ship.

3) Establishment of an analytical method to extract and analyze organic species at very low concentration levels for the analysis of oil and grease content found in bilge water and membrane permeate. This is an interesting part of the thesis since the literature contains few references regarding the analysis of oil and grease in treated bilge water at very low concentration levels from membrane permeates. Analytical results obtained from this study also support the conclusions we made in element 2.

4) Investigation of environmentally friendly membrane cleaning methods. The contribution of this study is the development of environmentally friendly physical cleaning methods, such as backflushing with hot water or steam followed by

pressurized air, for the treatment of bilge water using microfiltration and ultrafiltration, which will avoid the supply, storage, disposal and handling problems caused by using chemical or bioactive agents for cleaning in ship-born applications.

5) Study of filtration mechanism in the treatment of bilge water using ultrafiltration and microfiltration. The contribution of this study to the thesis is the investigation of the filtration mechanism for various pore size membranes using four classical filtration models and a combined model.

Throughout the studies of the above five elements, the synthetic bilge water make-up was not changed, identical sampling and measuring techniques were used, and the same analytical apparatus was employed.

4. New Knowledge Gained from this Study

The following is a list of contributions from this work:

- 1) The successful treatment of waste brines containing high concentration levels of oil to non-detectable levels.
- 2) Development of a membrane cascade system to treat bilge water in ship-born applications while minimizing concentrate production.
- 3) Establishment of an analytical method to extract and analyze organic species at very low concentration levels for the analysis of oil and grease content found in bilge water and membrane permeates.
- 4) Determination of the status of oil droplets after membrane microfiltration.
- 5) Development of environmentally friendly membrane cleaning methods using hot water, steam and backflushing.

6) Determination of membrane filtration mechanism in the treatment of oily waste water.

A total of six research papers have been produced based on the above five elements. These papers are presented in this thesis from Chapter II to Chapter VII (Paper 1 to Paper 6).

The objective of Paper 1 (Chapter II) was to evaluate the feasibility and performance of bilge water treatment to meet coastal discharge limit (15 ppm) using a pilot scale microfiltration/ultrafiltration (MF/UF) hybrid membrane system. Literature searches indicated that membrane technology was able to reduce oil content to 10-100 ppm for oily wastes (Cheryan and Rajagopalan, 1998), 20 ppm for oilfield brine (Zaidi et al., 1992), 5-15 ppm for bilge water (Karakuiski et al., 1998; Gryta et al., 2001; Tomaszewska et al., 2005). Applications of membrane hybrid system, such as conventional treatment followed by membrane filtration, or dual membrane systems, offers the potential to reach very low discharge levels (Camp, 1995; Lozier and Jones, 1997; Chellam et al., 1997; Vigneswaran et al., 2003; Seo et al., 1997; Karakuiski et al., 1998; Gryta et al., 2001; Tomaszewska et al., 2005). Literature review also showed that various sizes of oil droplets can be found during membrane filtration (Vladislavljević et al., 2002; Madaeni and Yeganeh, 2003; Faibish and Cohen, 2001) and a study reported that droplet coalescence in membrane pores led to nano-scale oil aggregates in the permeate (Lipp et al., 1988). In this paper, experiments were performed to treat a synthetic bilge water mixture in a pilot scale membrane hybrid system consisting of a coalescing backflushed microfiltration membrane used as a pretreatment and an ultrafiltration membrane as a final polishing step. The pilot system was equipped to perform the backflushing (BF) of the MF membranes and send permeate to the UF membranes for further treatment. Two microfiltration membranes were studied; single tube carbon membrane and multilumen ceramic membranes. The optimal backflushing cycle was determined for the single tube carbon membrane. The best operating conditions to obtain maximum steady state permeate flux using permeate backflushing were determined. Backflushing pressure, trans-membrane pressure, type

of membrane and different cleaning methods were also found to have a considerable effect on permeate flux. The particle size distribution of bilge water and UF membrane pore size were related to membrane performance. The clearance of the support structure with respect to particulates was found to be important. The work outlined the need for microfiltration membranes offering good particulate clearance to be used in backflushing coalescence applications. The MF/UF hybrid membrane system was found to be very effective in this application, producing permeate with oil and grease content well below the allowable discharge limit (15 ppm) for coastal waters. Paper 1 was published in **Desalination** in 2005.

The objective of Paper 2 (Chapter III) was to develop a pilot scale membrane cascade for selective removal of oil to 0 ppm or non-detectable levels from bilge water while minimizing concentrate production. The literature contains few references regarding the separation of oil or organics from saline water to very low oil concentration levels. Usually the objective is to remove oil from wastewater or salt from seawater, but not to remove oil from salty brine. The high divalent salt content in bilge water limits the type of technology that can be used to totally remove oil from these solutions. In addition to this, our objective in this study was to obtain very high purity effluent for eventual discharge in sensitive environments. However, transporting and managing adsorbents and other chemicals onboard ships have many disadvantages such as storage, handling, cost, regeneration and disposal. Based on the knowledge and experience we gained from the Paper 1, a pilot scale membrane cascade system was designed and evaluated. This system evaluated the use of tubular MF and UF membranes in a first stage, where high levels of particulate matter are present, and more compact flow cells representing spiral wound modules in the second stage. Optimal membrane pore sizes in the second loop were determined. The separation of oil and grease using different molecular weight cut-off (MWCO) membranes was performed. This study also investigated the size of oil particles in membrane permeates. Results of the research conducted in this study suggested that it is possible to achieve the objective of this study through the proper design of the membrane system, selection of appropriate membranes, determination of

optimal operating parameters, and assessment of membrane performance. Paper 2 has been accepted for publication in **Desalination**.

The objective of Paper 3 (Chapter IV) was to establish an appropriate analytical method to extract and analyze organic species at very low concentration levels for the analysis of oil and grease content found in bilge water and membrane permeates. Literature searches have been performed to review appropriate methods to analyze oil and grease concentration at very low levels (below 1 ppm or non-detectable levels). Several methods are available in the literature for the determination of oil and grease in water (U.S.EPA, 1999; APHA et al., 1995; ASTM, 2004). Solid phase extraction (SPE) methods and gas chromatography (GC) methods are also reported in literature (Nottegar and Tremblay, 2000; Langenfeld et al., 1996; Saraullo et al., 1997; Daiminger et al., 1995; ISO, 1999; Wang et al., 1994a, 1994b, 1994c and 1995; Wang, 2002). However, the literature contains few references regarding the analysis of oil and grease at very low concentration levels from membrane permeates. The establishment of an appropriate analytical method to extract and analyze organic species at very low concentration levels for the analysis of oil and grease content found in bilge water is definitely needed. The GC method appears to be a better choice for this work. The key point for the success of this objective is to select the appropriate extraction technique and identify appropriate parameters for the GC. In this study, permeates of various MWCO membranes from a pilot scale MF/UF membrane cascade system were collected and analyzed using an extraction procedure followed by gas chromatography. This work investigated the effects of solid phase extraction and n-Hexane liquid-liquid extraction for the determination of the molecular weight distribution in the oil mixture used to prepare synthetic bilge water. Possible matrix effects likely caused by the presence of a detergent in the synthetic bilge water mixture were studied. Paper 3 will be submitted for publication shortly.

The objective of Paper 4 (Chapter V) was to study the effect of membrane MWCO in separation of oil and grease. Permeates of various MWCO membranes from a pilot scale MF/UF membrane cascade system were collected and analyzed based on the

analytical method developed in Paper 3. Oil rejection rates from bilge water for different MWCO membranes were determined through this study. Experimental results were interpreted by membrane pore size, the aliphatic and aromatic content of the permeates, and the presence of nanosized particles in the membrane permeates. Paper 4 will be submitted for publication.

The objective of Paper 5 (Chapter VI) was to investigate environmentally friendly membrane cleaning methods in treating oily wastewaters. The literature search indicated that various cleaning approaches have been used to regenerate permeate flux. Membrane cleaning methods can be broadly categorized into four types: chemical, physical, physico-chemical and biological. Chemical methods are the most widely used procedures in membrane cleaning. Many studies can be found in the literature using various cleaning agents such as; alkalies, acids, enzymes, surfactants, sequestering agents, formulated agents and disinfectants (Ebrahim, 1994; Trägårdh, 1989; Sadhwani and Veza, 2001; Wallberg et al., 2001; Zhang and Liu, 2003; Weis et al., 2003). However, the drawbacks of chemical cleaning methods include: the generation of new waste solutions; higher costs; and the operational aspects of chemical supply and handling problems, especially in a ship or remote places. Physical methods depend on mechanical treatment to remove foulants from the surface of the membrane and enhance cleaning effectiveness. These mechanical treatments include: sponge ball cleaning (Yanagi and Mori, 1980), air sparging (Takizawa et al., 1996), vibration (Ebrahim, 1994), ultrasonication (Matsumoto et al., 1996), and backflushing (Levesley and Hoare, 1999; Kim and Chang, 1991; Vigneswarne et al., 1996; Srijaroonrat et al., 1999; Natasuka et al., 1996). Physical methods are good for removing the cake produced on the surface of the membrane, but they are associated with operational problems and a lack of efficiency. For example, the operation and handling of sponge ball cleaning equipments is not a simple task. The use of backflushed coalescing microfiltration for the pre-treatment of oily wastewaters prior to ultrafiltration is an interesting technique offering potential as a physical pretreatment method. This concept has been developed through our research findings presented in Paper 1. The concept of this technique is to pre-treat oily wastewaters with a large pore

microfiltration membrane operated with backflushing where the oils are partly coalesced in the pores of the membrane. The permeate from this membrane can then be treated by ultrafiltration. The coalescing membrane must eventually be regenerated in order to maintain a desirable permeate flux. In this study, we investigated environmentally friendly physical membrane cleaning methods, such as backflushing with hot water or steam followed by pressurized air. The treatment of oily wastewater containing half seawater using a MF/UF hybrid system was studied in this work. The beneficial effects for steam cleaning were found to be evident. Optimal cycle times between physical cleanings were determined. The results were also modeled using four traditional fouling models and a combined filtration model. Paper 5 has been submitted to a journal for publication.

The objective of Paper 6 (Chapter VII) was to study the filtration mechanism in the treatment of bilge water using ultrafiltration and microfiltration. Membrane fouling occurs due to particle-particle and particle-membrane interactions. Fouling causes a decline in permeate flux and a change in membrane selectivity. Membrane fouling remains a poorly understood phenomenon. Hermia (1982) developed the constant pressure blocking filtration laws and proposed the following four filtration mechanisms: complete pore blocking, intermediate pore blocking, standard blocking and cake filtration. Since then, a number of workers have published their filtration mechanism research results on various topics (Bowen et al., 1995; Iritani et al., 1995; Ruohomäki et al. 2000; Yuan et al., 2002; Kosvintsev et al., 2002; Fratila-Apachitei et al., 2001; Ohya et al., 1998; Arnot et al., 2000; Ho and Zydney, 2003). It would be very interesting to investigate the filtration mechanism of various pore size membranes for the treatment of this particular oily salty wastewater in our current work. In this paper, various pore size ceramic UF and MF membranes were employed in this study. Experimental results were investigated using four classical filtration models and a combined model. The results were further interpreted by membrane pore size, membrane module configuration, the presence of particulates and emulsified oil in this particular oily salty wastewater. Paper 6 will be submitted for publication.

REFERENCES

- Alper, H., "Regulatory and technological developments in the treatment of oily bilge water", Paper presented at the 9TH International Conference on Marine Engineering Systems, Helsinki, Finland, May 19-21, (2003).
- American Public Health Association (APHA), American Water Works Association (AWWA), and Water Environment Federation (WEF), Standard methods for the Examination of Water and Wastewater, 19th ed., Washington, DC, (1995).
- Arnot, T.C., R.W. Field, A.B. Koltuniewicz, "Cross-flow and dead-end microfiltration of oily-water emulsions. Part II. Mechanisms and modeling of flux decline", *J. Membr. Sci.* 169 1-15 (2000).
- ASTM D3921-96 (2003) E1. Standard test method for oil and grease and petroleum hydrocarbons in water, Annual Book of ASTM Standards, Philadelphia, 11.02: 360-366, (2004).
- Bhattacharyya, D., A.B.Jumawan, R.B.Grieves and L.R.Harris, "Ultrafiltration Characteristics of Oil-Detergent-Water Systems: Membrane Fouling Mechanisms", *Journal of Separation Science and Technology* 14(6) 529-549 (1979).
- Bowen, W.R., J.I. Calvo, A. Hernández, "Steps of membrane blocking in flux decline during protein microfiltration", *J. Membr. Sci.* 101 153-165 (1995).
- Camp, P., "Integral approach of surface water treatment using ultrafiltration and reverse osmosis", proceedings of AWWA membrane technology conference, August 13-16, Reno, Nevada, USA, 31-38 (1995).
- Chellam, S., J.G. Jacangelo, T.P. Bonacquisti, and B.A. Schauer, "Effect of Pretreatment on Surface Water Nanofiltration", *Journal of the American Water Works Association* 89 (10) 77-89 (1997).
- Cheryan, M. and N. Rajagopalan, "Membrane Processing of Oily Streams. Wastewater Treatment and Waste Reduction", *Journal of Membrane Science* 151 13-28 (1998).
- Daiminger, U., W.Nitsch, P.Plucinski and S.Hoffmann, "Novel techniques for oil/water separation", *Journal of Membrane Science* 99 197-203 (1995).
- Ebrahim, S., "Cleaning and regeneration of membranes in desalination and wastewater applications: State-of-the-art", *Desalination* 96 225-238 (1994).
- Faibish, R.S., and Y. Cohen, "Fouling-resistant ceramic-supported polymer membranes for ultrafiltration of oil-in-water microemulsions", *Journal of Membrane Science* 185 129-143 (2001).

- Fratila-Apachitei, L.E., M. D. Kennedy, J.D. Linton, I. Blume, J. C. Schippers, "Influence of membrane morphology on the flux decline during dead-end ultrafiltration of refinery and petrochemical waste water", *J. Membr. Sci.* 182 151-159 (2001).
- Gryta, M., K.Karakulski and A.W.Morawski, "Purification of oily wastewater by hybrid UF/MD", *Wat. Res.* 35(15) 3665-3669 (2001).
- Hermia, J., "Constant Pressure Blocking Filtration Laws: Applications to Power-law Non-newtonian Fluids", *Trans. Inst. Chem. Eng.* 60 183-187 (1982).
- Ho, C.C. and A.L. Zydney, Effect of Membrane morphology on system capacity during normal flow microfiltration, *Biotechnol. Bioeng.* 83 (5) 537-543 (2003).
- IMO (International Maritime Organization), MEPC.5/Circ.6, "Pollution prevention equipment required by MARPOL 73/78", London, U.K., July (2002).
- International Organization for Standardization (ISO), ISO/DIS 9377-4. Water quality – Determination of hydrocarbon oil index – Part 4: Method using solvent extraction and gas chromatography, (1999).
- Iritani, E., Y. Mukai, y. Tanaka, T. Murase, "Flux decline behavior in dead-end microfiltration of protein solutions", *J. Membr. Sci.* 103 181-191 (1995).
- Karakuiski, K., W.A.Morawski and J. Grzechulska, "Purification of bilge water by hybrid ultrafiltration and photocatalytic processes", *Separation and Purification Technology* 14 163-173 (1998).
- Kim, B.S. and H.N. Chang, "Effects of Periodic Backflushing on Ultrafiltration Performance", *Bioseparation* 2 23-29 (1991).
- Kosvintsev, S., R.G. Holdich, I.W. Cumming, V.M. Starov, "Modeling of dead-end microfiltration with pore blocking and cake formation", *J. Membr. Sci.* 208 181-192 (2002).
- Langenfeld, J.J., S.B.Hawthorne and D.J.Miller, "Quantitative analysis of fuel-related hydrocarbons in surface water and waste water samples by solid-phase microextraction", *Analytical Chemistry* 68 144-155 (1996).
- Levesley, J.A. and M.Hoare, "The Effect of High Frequency Backflushing on The Microfiltration of Yeast Homogenate Suspensions for the Recovery of Soluble Proteins", *Journal of Membrane Science* 158 29-39 (1999).
- Lipp, P., C.H.Lee, A.G.Fane and C.J.D.Fell, "A Fundamental Study of The Ultrafiltration of Oil-Water Emulsions", *Journal of Membrane Science* 36 161-177 (1988).

- Lozier, J. and G. Jones, "Meeting the challenges of the new drinking water regulations with dual-membrane treatment", proceedings of AWWA membrane technology conference, New Orleans, USA, February (1997).
- Madaeni, S.S. and M.K. Yeganeh, "Microfiltration of Emulsified Oil Wastewater", *Journal of Porous Materials* 10 131-138 (2003).
- Matsumoto, Y., T. Miwa, S. Nakao, S. Kimura, *J Chem Eng Jpn*, 29 (4) 233-239 (1996).
- Natasuka, S., I. Nakate, T. Miyano, "Drinking Water Treatment by Using Ultrafiltration Hollow Fiber Membranes", *Desalination* 106 55-61 (1996).
- Nottegar, M. and A.Y. Tremblay, "Bilge Water Membrane Treatment Phenomena Study", contract W7707-7-5321, report prepared for Department of National Defence (DND), Ottawa, Canada, (2000).
- Ohya, H., J.J. Kim, A. Chinen, M. Aihara, S. I. Semenova, Y. Negishi, O. Mori, M. Yasuda, "Effects of pore size on separation mechanisms of microfiltration of oily water, using porous glass tubular membrane", *J. Membr. Sci.* 145 1-14 (1998).
- Ruohomäki, K. and M. Nyström, Foulings of ceramic capillary filters in vacuum filtration of humic acid, *Filtr. Sep.* 37 51-57 (2000).
- Sadhvani, J.J. and J. M. Veza, "Cleaning tests for seawater reverse osmosis membranes", *Desalination* 139 177-182 (2001).
- Saraullo, A., P.A. Martos and J. Pawliszyn, "Water analysis by solid-phase microextraction based on physical-chemical properties of the coating", *Analytical Chemistry* 68 1992-1998 (1997).
- Seo, G.T., T.S. Lee, B.H. Moon, K.S. Choi and H.D. Lee, "Membrane separation activated sludge for residual organic removal in oil wastewater", *Wat.Sci.Tech.* 36(12) 275-282 (1997).
- Srijaroonrat, P. E. Julien, Y. Aurelle, "Unstable Secondary Oil/Water Emulsion Treatment Using Ultrafiltration: Fouling Control by Backflushing", *Journal of Membrane Science* 159 11-20 (1999).
- Takizawa, S., K. Fujita, K. H. Soo, "Membrane fouling decrease by microfiltration with ozone scrubbing", *Desalination* 106 423-426 (1996).
- Tomaszewska, M., A. Orecki, K. Karakulski, "Treatment of bilge water using a combination of ultrafiltration and reverse osmosis", *Desalination* 185 203-212 (2005).
- Trägårdh, G., "Membrane cleaning", *Desalination* 71 325-335 (1989).

Transport Canada, "Canada Shipping Act", Ottawa, Canada, (2001).

Vigneswaran, S., D. S. Chaudhary, H.H. Ngo, W. G. Shim and H. Moon, "Application of a PAC-membrane hybrid system for removal of organics from secondary sewage effluent: experiments and modeling", *Separation Science and Technology* 38(10) 2183-2199 (2003).

U.S.EPA Method 1664 Revision A: n-Hexane Extractable Material (HEM; Oil and Grease) and Silica Gel Treated n-Hexane Extractable Material (SGT-HEM; Nonpolar Material) by Extraction and Gravimetry. EPA-821-R-93-009. EPA Office of Water. (1999).

Vigneswarne, S., S.Boonthanon, H.Prasanthi, "Filtration Backwash Recycling Using Crossflow Microfiltration", *Desalination* 106 31-38 (1996).

Vladisavljević, G.T., S. Tesch and H.Schubert, "Preparation of water-in-oil emulsions using microporous polypropylene hollow fibers: influence of some operating parameters on droplet size distribution", *Chemical Engineering and Processing* 41 231-238 (2002).

Wallberg,O., Ann-Sofi Jönsson, P. Wickström, "Membrane cleaning – a case study in a sulphite pulp mill bleach plant", *Desalination* 14 259-268 (2001).

Wang, Z., Fingas M. and Ken L., "Fractionation of ASMB oil, and identification and quantitation of aliphatic and aromatic and biomarker compounds by GC/FID and GC/MSD (Part I)", *J. Chromatogr. Sci.* 32 361-366 (1994a).

Wang, Z., Fingas M. and Ken L., "Fractionation of ASMB oil, and identification and quantitation of aliphatic and aromatic and biomarker compounds by GC/FID and GC/MSD (Part II)", *J. Chromatogr. Sci.* 32 367-382 (1994b).

Wang, Z., Fingas M. and Gary S., "Study of 22-year-old arrow oil samples using biomarker compounds by GC/MS", *Environmental Science and Technology* 28 1733-1746 (1994c).

Wang, Z., Fingas M. and Gary S., "Chemical characterization of crude oil residues from an Arctic beach by GC/MS and GC/FID", *Environmental Science and Technology* 29 2622-2631 (1995).

Wang, Z., "Analytical Methods for the Determination of Individual (n-Alkanes and Isoprenoids) and Total Petroleum Hydrocarbons (TPH), Polycyclic Aromatic Hydrocarbons (PAHs) and Biomarker Triterpanes and Steranes in Oil and Oil-spill-related Environmental Samples (Water, Particulates and Soils/Sediments)", *Environmental Technology Centre, Environment Canada, Ottawa, Canada, (2002).*

Weis, A., M. R. Bird, M. Nyström, “The chemical cleaning of polymeric UF membranes fouled with spent sulphite liquor over multiple operational cycles”, *Journal of Membrane Science* 216 67-79 (2003).

Yanagi, C. and K. Mori, “Advanced reverse osmosis process with automatic sponge ball cleaning for the reclamation of municipal sewage”, *Desalination* 32 391-398 (1980).

Yuan, W., A. Kocic, A.L. Zydney, “Analysis of humic acid fouling during microfiltration using a pore blockage-cake filtration model”, *J. Membr. Sci.* 198 51-62 (2002).

Zaidi, A., K. Simms and S. Kok, “The use of micro/ultrafiltration for the removal of oil and suspended solids from oilfield brines”, *Wat. Sci. Tech.* 25 (10) 163-176 (1992).

Zeman, L.J. and A.L.Zydney, “Microfiltration and Ultrafiltration, Principles and Applications”, Marcel Dekker, Inc. 331-341, 380-381, 575-576 (1996).

Zhang, G. and Z. Liu, “Membrane fouling and cleaning in ultrafiltration of wastewater from banknote printing works”, *Journal of Membrane Science* 211 235-249 (2003).

CHAPTER II

The use of backflushed coalescing microfiltration as a pretreatment for the ultrafiltration of bilge water.

H. Peng^a, A.Y. Tremblay^{a*}, D. E. Veinot^b

*^aUniversity of Ottawa, Department of Chemical Engineering, Ottawa, ON,
Canada*

*^bDefence R&D Canada- Atlantic, Dockyard Laboratory (A), Halifax, NS,
Canada*

*Corresponding author

André Y. Tremblay

Tel.: +1-613-562-5920; Fax: +1-613-562-5172

E-mail address: tremblay@uottawa.ca

Article has been published in: **Desalination, 181 (2005) 109-120.**

CHAPTER II (Paper 1)

The use of backflushed coalescing microfiltration as a pretreatment for the ultrafiltration of bilge water.

H. Peng^a, A.Y. Tremblay^{a*}, D. E. Veinot^b

*^aUniversity of Ottawa, Department of Chemical Engineering, Ottawa, ON, Canada
Tel.: +1-613-562-5920; Fax: +1-613-562-5172; E-mail address: tremblay@uottawa.ca*

^bDefence R&D Canada- Atlantic, Dockyard Laboratory (A), Halifax, NS, Canada

Received 16 March 2004; accepted 7 December 2004

*Corresponding author.

Abstract

Ships produce a large amount of oily wastewaters such as bilge water which needs to be treated prior to being discharged. Bilge water is a difficult wastewater to treat as it contains seawater, particulates, used oils and detergents. Ultrafiltration (UF) is the method of choice to treat this wastewater. The pretreatment of this oily wastewater, prior to ultrafiltration, is desirable as used oils and particulates can block the feed channels of UF spiral and hollow fiber modules. A cascaded membrane system consisting of a coalescing backflushed microfiltration membrane used as a pretreatment and an ultrafiltration membrane were studied. Two microfiltration membranes were studied; single tube carbon membrane and multilumen ceramic membranes. The optimal backflushing cycle was determined for the single tube carbon membrane. The particle size distribution of bilge water and UF membrane pore size were related to membrane performance. Experimental results showed that membranes with a pore size below 0.2 microns can be used directly to treat bilge water. Microfiltration membranes responded well to backflushing with flux enhancements of up to 8 times compared to the case of cross-flow alone. Backflushing of MF membranes offered flux improvements for single tube carbon membranes but not for multilumen ceramic membranes. The clearance of the support structure with respect to particulates was found to be important. The single carbon tube had a shorter path compared to the longer path of the multilumen ceramic tube. The work outlines the need for microfiltration membranes offering good particulate clearance to be used in

backflushing coalescence applications. The MF/UF hybrid membrane system was found to be very effective in this application, producing permeate with oil and grease content well below the allowable discharge limit for coastal waters.

Keywords: Coalescing; Backflushing; Microfiltration; Ultrafiltration; Bilge water; Membrane pore size

1. Introduction

One of the marine industry's primary environmental concerns is the overboard discharge of liquid wastes. The discharge of wastewater must meet more stringent waste-disposal regulations imposed by local, national and international authorities. Recently shipping companies have been severely fined for the release of oily wastewater to the environment. A major source of overboard discharge is bilge water, a wastewater that accumulates in the lowest internal part of a ship. Bilge water is an oily wastewater composed of a complex "cocktail" of mechanical and chemical emulsions, and contaminants. This oily wastewater differs from those found in the petrochemical and automotive industries or in domestic sewage operations. Bilge water is a mixture of fresh and seawater. It contains a variety of salts and is very corrosive. Therefore, it is more appropriate to refer to bilge water as an oily brine. Bilge contaminant characteristics and generation rate depend on the type of ship and its operation mode [1]. Typical contaminants may include fuels, oils, detergents, greases, solvents, rusts, paints, insulation material and a wide variety of other substances. The varied nature and composition of bilge water poses a more difficult separation problem than the treatment of conventional oil in water emulsions.

Membrane technology in wastewater treatment has moved forward quickly in recent years because of the development of new technologies for the manufacture of membranes. Membrane ultrafiltration (UF) has been identified as a key technology in the treatment of oily wastewaters [2]. Microfiltration (MF) membranes with a pore size of 0.1 micrometer (μm) were found to be effective in the separation of oily wastewaters and the recovery of surfactant in the feed [3]. Most membrane companies

recommend using membranes with molecular weight cut-offs of 20,000-50,000 Daltons for the treatment of oily wastewater [4]. This can typically result in a permeate with less than 10-100 ppm of oil, unless high concentrations of a soluble surfactant or polar solvent are present [4].

Both polymeric and ceramic membrane materials are used in oily wastewater treatment. Membranes with improved oil resistance have been developed during the past two decades. Much work has been conducted on oily wastewater treatment and good separation results were reported using different membrane materials [5-9].

Backflushing and backpulsing are effective processes to remove deposits from the surface of the membrane and improve the membrane productivity. Backflushing refers to low-frequency permeate flow reversal while backpulsing refers to high-frequency permeate flow reversal. In both processes, the trans-membrane pressure is periodically reversed. Many studies have focused on this technique. Rodgers and Sparks [10] studied backpulsing in protein solutions with ultrafiltration and reported on the effect of concentration. The backpulsing technique was efficient when the feed concentration was between 10 and 30 g/l while at 100g/l, the permeate flux did not increase. Vigneswaran et al. [11] reported results on the MF of filter backwash water from a wastewater treatment plant. They determined an optimum cycle of 1 min and backflushing duration of 1s. Srijaroonrat et al. [12] used ceramic membranes to evaluate the treatment of an unstable secondary emulsion. They observed the contamination of the permeate with oil when using 0.5 micron MF membrane. They also found that, when applying backflushing, the optimum forward filtration and reverse filtration times were 1 min and 0.7 s, respectively.

Ramirez and Davis [13] studied crossflow MF with rapid backpulsing for the treatment of aqueous clay suspensions of different concentration, as well as for a dilute crude oil-in-water dispersions. They reported that for clay, rapid backupulsing can maintain the permeate flux at a level that is more than ten-fold over the steady-state flux in the absence of backpulsing; for oil-in-water dispersions, rapid backpulsing can increase the

permeate flux by up to 25 times without any reduction in the permeate quality. Levesley and Hoare [14] studied the effect of periodic backflushing on the microfiltration of yeast homogenate suspensions for the recovery of soluble proteins. They found that high frequency backflushing could increase the transmission of proteins during microfiltration of disrupted cell suspensions at high concentration, without significantly affecting the observed permeate flux. Up to six-fold increase in the mass flux of a target enzyme was obtained by backflushing. Sondhi et al. [15] conducted crossflow filtration experiments with $\text{Cr}(\text{OH})_3$ suspension as synthetic electroplating wastewater using ceramic MF membranes of various pore sizes (0.2-5.0 μm). They concluded that backflushing was effective in reducing fouling resulting in up to a five-fold increase in the steady state permeate flux and 100% flux recovery compared to the conventional non-backflushed case. A recent study by Kuberkar and Davis [16] investigated crossflow microfiltration using yeast suspensions, bovine serum albumin (BSA) solutions, and mixtures of yeast and BSA with and without crossflushing or backflushing. They reported that both crossflushing and backflushing are more effective against yeast fouling than against BSA fouling, with backflushing being the more effective of the two methods.

These studies suggest that backflushing is a technically feasible and effective method to enhance crossflow filtration. However, the efficacy of backflushing seems to vary with frequency of backflushing, the solution being treated and membrane/particle interactions. A limited amount of information is available in the literature related to the application of membrane systems in bilge water treatment. A previous study performed by Nottegar and Tremblay [17] indicated that bilge water is a very challenging wastewater to treat due to the type and the size of particulate matter in solution. In a North Atlantic Treaty Organization (NATO) expert workshop on Oily Water Separators held in 1999, many countries reported on the difficulties associated with pretreatment before oily water separators [17]. Many problems related to the long-term efficacy of the membranes and issues related to the proper sizing of channels (lumens) within membrane modules remain due to the presence of used oil, detergent and salts in this oily brine containing seawater.

In this study, separation of synthetic bilge water was carried out using a MF/UF cascade. The purpose of the backflushed microfiltration system is to loosely coalesce the particulate and oil laden bilge water and return the coalesced oil into the feed. Absolute separation of all the oil in the bilge water is not essential during the MF step but the removal of oily aggregates containing particulates found in the bilge water is important in order to use more economical densely packed ultrafiltration modules in the ultrafiltration step. The MF system uses ultrafiltered permeate for backflushing. It is easily automated and requires little supervision, an important feature onboard ships. The optimal backflushing cycles were determined and the effects of membrane pore size and membrane support structure were investigated. In practice, bilge water is accumulated in a tank onboard a ship and treated in a batch run. The impact of increasing oil concentration in the feed during a batch run was also studied.

2. Experimental

2.1 Bilge water preparation

Synthetic bilge water was prepared from constituents described in a study performed by the Canadian Navy [18]:

- i) 2000-mg/L oils,
- ii) 500-mg/L detergents and surfactants, and
- iii) 50/50 mixture of fresh water + seawater (approximately 99.75%).

This formed the basis for the makeup of the standard bilge water solution used in most tests. The oils were composed of the following:

- i) 50% naval distillate (diesel fuel),
- ii) 40% used naval diesel engine lubricating oil, and
- iii) 10% hydraulic oil.

The detergents and surfactants were composed of the following:

- i) 90% oil and grease detergent (CLEANBREAK)

- ii) 10% corrosion removal compound (OSTREM Rust Stain Remover).

Synthetic ocean water was prepared according to “Standard Specification for Substitute Ocean Water”, ASTM D1141-90 (1992) [19].

2.2 Membranes

2.2.1 Carbon membrane

The KOCH Carbon membrane (KOCH Membrane Systems, Ann Arbor, Michigan, USA) was made from sintered carbon. The characteristics of this membrane are shown in Table 1.

Table 1: KOCH Carbon Membrane Characteristics.

Membrane configuration	Tubular (single channel)
Inside diameter, mm	6
Outside diameter, mm	8
Length, mm	1200
Membrane area, m ²	0.022
Maximum operating pressure, psig	600
Maximum backpulsing pressure, psig	1500
Maximum operating temperature, °C	165
Pore size tested, μm	0.05, 0.1, 0.2, 0.5, 0.8, 1.4

2.2.2 Ceramic membrane

TAMI Céram membranes (TAMI Industries, Nyons, France) are multi channel tubular ceramic membranes. Table 2 shows membrane characteristics.

Table 2: TAMI Céram Membrane Characteristics.

Name	Daisy	Dahlia
Membrane configuration	Tubular (8 channels)	Tubular (39 channels)
Inside diameter, mm	6	2.5
Outside diameter, mm	25	25
Number of channel	8	39
Surface area, m ²	0.2	0.5
Length, ft	4	4
Pore size (μm) or MWCO (kDaltons)	1.4, 0.8 & 0.07 micron and 300 & 150 kD	50 kD

2.2.3 Polymeric membrane

The KOCH XM50 polymeric hollow fiber membrane (KOCH Membrane Systems, Ann Arbor, Michigan, USA) was employed. The membrane is made of polyvinyl chloride/polyacrylonitrile (PVC/PAN) co-polymer. The characteristics of KOCH XM50 membrane are summarized in Table 3 below.

Table 3: KOCH XM50 Hollow Fiber Membrane Characteristics.

Membrane Configuration	Hollow fiber
Composition	PVC/PAN (co-polymer)
Nominal MWCO, Dalton	50,000
Length, m	0.417
Surface area, m ² (ft ²)	0.092416 (1)

2.3 Experimental set-up

Membrane MF/UF pilot tests were performed in the system shown in Figure 1. There are two membrane circulation loops in this system, the MF loop served as a backflushed coalescing pretreatment to the UF loop. During the experimental runs, MF permeate was sent to the UF loop while MF concentrate was circulated back to feed tank. Four

pumps were employed in the system; one acted as a feed pump feeding bilge water to the MF loop, a second pump was used to circulate feed in the MF loop, a third pump circulated fluid in the UF loop and a pneumatic diaphragm pump, acted as a backflushing pump, drawing a suction from the permeate tank to backflush the MF membrane module. The contents of the feed tank were continually mixed to prevent the de-phasing of the bilge water.

Permeate from the UF loop was collected in a small 8 L permeate tank. The level in the tank was monitored to determine permeate flowrate. Liquid in the tank was used to backflush the membranes as required. The permeate tank was linked to a pneumatic valve which served as a backflushing valve. The valve was computer-controlled. This valve was normally closed. During the backflushing operation the valve was opened and the permeate was backflushed through the MF membrane. The total operational cycle time and the backflushing times were set by the operator and controlled by the computer.

The temperature of the system was controlled by a water-cooled coil in the feed tank. A platinum RTD (Resistance Temperature Detector) probe placed in the MF loop provided an accurate measure of the feed temperature. A computer operated ON/OFF pneumatic valve controlled the flow of water through the coil in the tank. Once the temperature in the system reached its set point, the system was able to maintain the temperature of the feed solution within $\pm 0.1^{\circ}\text{C}$ of the set point.

The temperature, pressure, flux of permeate and retentate were graphically displayed on the PC screen and recorded. LABVIEW software (National Instruments) was used to control the system and acquire the data.

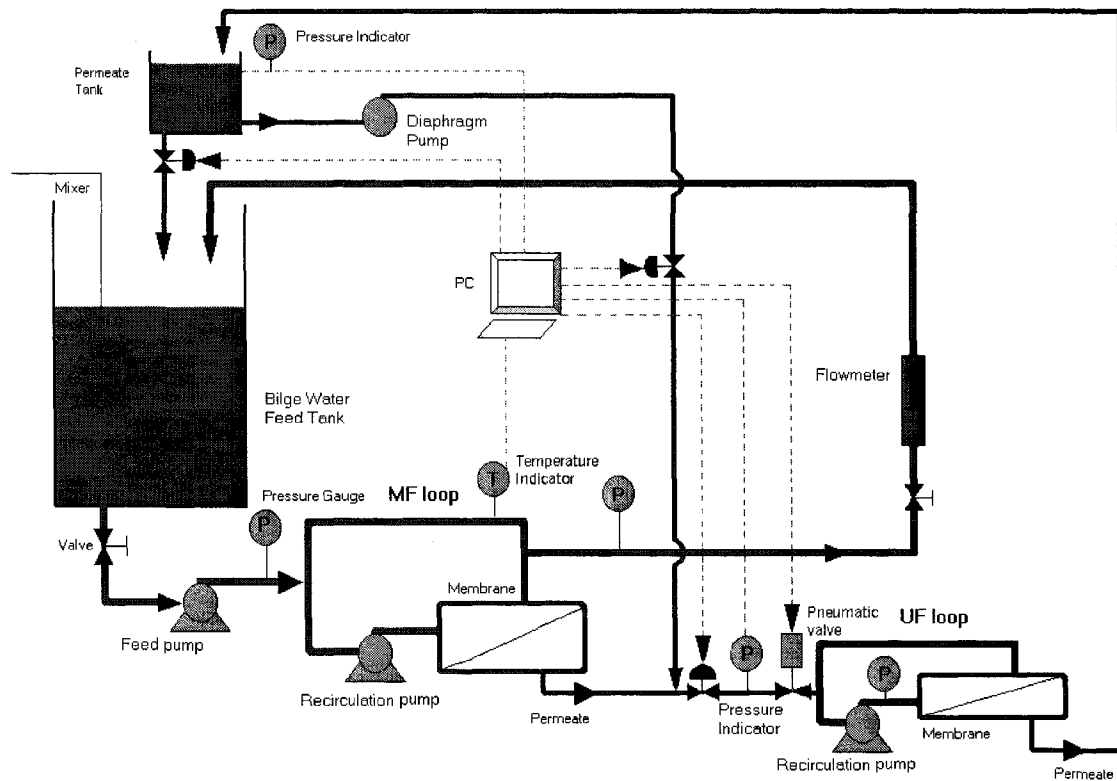

Figure 1: Schematic diagram of the MF/UF hybrid system.

2.4 Experimental procedure and analytical methods

All runs were carried out at a crossflow speed of 5 to 6 m/s. A test volume of 100 L synthetic bilge water was prepared at room temperature and mixed in the feed tank for several hours before each run. Normally, a run lasted for 3 to 6 days.

The new as received KOCH Carbo-cor membranes were cleaned according to the manufacturer's specification. The new larger pore size TAMI membranes (0.8 and 1.4 micron) were rinsed with water and used directly in the tests. The smaller pore size TAMI membranes (50, 150 and 300 kD) were wet with isopropanol prior to use in order to displace any air present in membrane pores. This was followed by several rinses with RO water until all traces of isopropanol had disappeared.

All membranes were cleaned prior to testing in a separate cleaning loop. Cleanings were performed three times with KLDII cleaner purchased from KOCH Membrane Systems Incorporated (Ann Arbor, Michigan, USA). The membranes were removed from the loop to prevent the contamination of the bilge water with the KLDII cleaning solution. The concentration of KLDII was 10 mL per litre of water. Washes were conducted at high crossflow velocities and low pressure (3-5 psig).

The operating temperature was controlled to $35 \pm 0.1^\circ\text{C}$. For different runs, there was slight difference in temperature due to change of operating conditions such as changes in room temperature and recovery within the MF loop which varied slightly throughout the runs. The results of permeate flux in this work were corrected to 25°C or 35°C in accordance with ASTM standard D5090-90: Standardizing Ultrafiltration Permeate Flow Performance as follows;

$$\text{Flux at } 25^\circ\text{C} = (\text{Flux @ Temp.}) * (1 + (25 - \text{Temp.}) * 0.03),$$

$$\text{Flux at } 35^\circ\text{C} = (\text{Flux @ Temp.}) * (1 + (35 - \text{Temp.}) * 0.03).$$

3. Results and discussion

3.1 Effect of pore size

3.1.1 KOCH carbon tubular membranes

In order to determine the effect of membrane pore size on flux reduction, a series of experiments were conducted with different pore size KOCH carbon membranes. These tests were performed in the experimental set-up shown in the MF/UF hybrid system (Figure 1) without using the UF loop, with standard amount of oils, detergents and surfactants in bilge water (2 g/L). Experimental results are summarized in Figures 2 and 3. The 0.05, 0.1 and 0.2 micron membranes were tested without backflushing and the 0.5 micron membrane with backflushing for 48 hours then without backflushing for the remainder of the run. The 0.1 and 0.2 micron membranes were cleaned after the first 24 hours of operation.

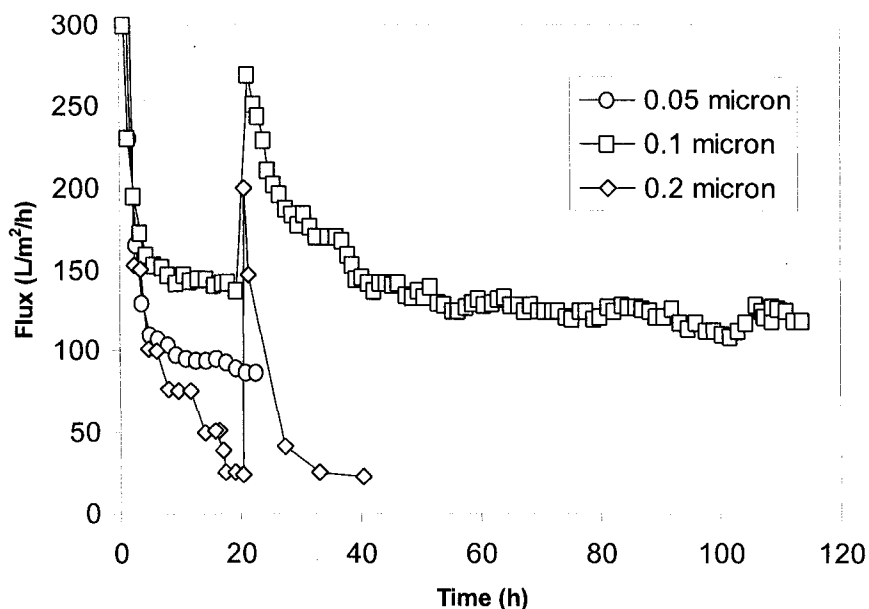

Figure 2: Plot of permeate flux vs. time for various KOCH carbon tubular membranes (Operating pressure 35 psig, 25°C. The 0.1 and 0.2 micron membranes were cleaned after the first 24 hours of operation).

As seen in Figure 2, the 0.1 micron membrane had an impressive sustained performance during five days of operation. Permeate flux declined to an unacceptable level for the 0.2 micron membrane after the first day of operation. After this initial test, it was decided to backflush membranes having pore sizes above 0.2 microns. The performance of a 0.5 micron membrane during backflushing was 150 L/m²/h for the first 2 days of operation as shown in Figure 3. When the backflushing stopped, a steep decline in flux was observed. These results show that the 0.2 micron pore size membrane is not a good choice for synthetic bilge water treatment. The results also indicate the effect of particles found in bilge water on the performance of the membranes suggesting that particles having a size of approximately 0.2 microns were present in the bilge water producing a steep flux decline due to pore plugging. For the larger pore size membrane (0.5 micron), flux was maintained at a relatively higher level with backflushing since backflushing continuously removed those particles entering the membrane pores. When no backflushing was applied to this membrane, particles accumulated in the pore and caused further flux decline.

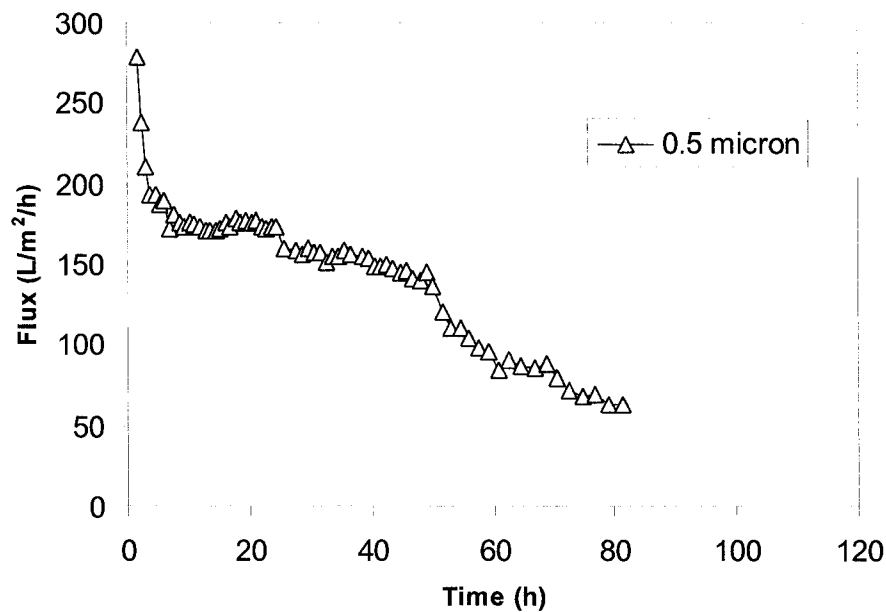

Figure 3: Plot of permeate flux vs. time for the KOCH carbon 0.5 micron membrane (Operating pressure 35 psig, 25°C. Backflushing up to 48 hours then no backflushing.)

Nottegar and Tremblay [17] studied the particle size distribution in synthetic bilge water. Their findings are shown in Figure 4 below. One particle distribution was centered around a size of 0.18 microns (0.089 micron radius) and the larger was centered around 2.68 microns (1.34 micron radius). The lower end of the larger size distribution was 1.8 microns (0.9 micron radius). In the presence of such particles, maximum pore blockage is expected for microfilters with pores falling in the 0.14 to 0.2 micron diameter range. Membranes having a pore size just below the value of 0.14 micron would have the best performance while those within the range are expected to be totally blocked and the larger pore sizes membranes would need backflushing to remove the gradual accumulation of particles within the pores. This is in excellent agreement with what is observed in Figures 2 and 3.

Therefore, membranes with a pore size below or above 0.2 micron should be used for synthetic bilge water treatment. Membranes with pore sizes lower than 0.2 micron do

not require backflushing. Membranes with pore sizes larger than 0.2 micron need backflushing to remove particles entering the pore and maintain permeate flux.

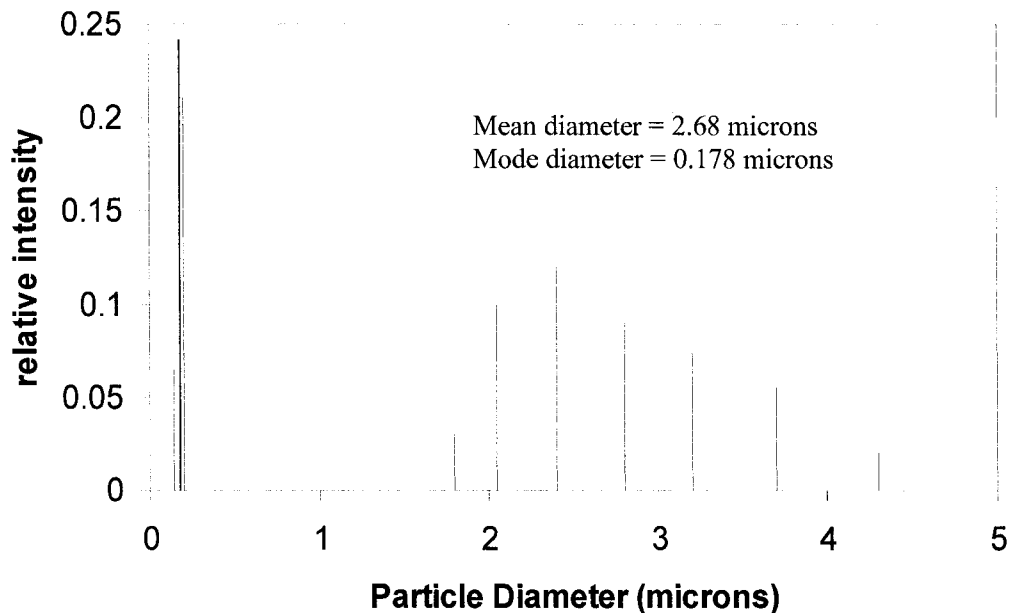

Figure 4: Particle size distribution for used oil. DLS measurements. Peaks for the smaller radii are at 0.07, 0.089 and 0.1 microns [17].

3.1.2 TAMI ceramic tubular membranes

Several TAMI membranes were tested to determine their performance in treating bilge water. These tests were performed in the experimental set-up shown in the MF/UF hybrid system (Figure 1) without the UF loop. The 0.8 and 1.4 micron pore size membranes were tested with backflushing. The smaller pore size membranes were tested without backflushing. The steady-state permeate flux data for all the TAMI membranes have been summarized and plotted in Figure 5 below, along with the experimental data for the KOCH carbon membranes.

It was found that for the TAMI membranes, below 70 nanometer (nm) pore size, the permeate flux increases gradually with an increase in pore size. The highest flux is for the 70 nm pore size membrane. Above 70 nm pore size, the permeate flux decreases substantially even in the presence of backflushing. The largest pore size membrane

(1.4 micron) has the lowest permeate flux. Membrane pore sizes were estimated from the molecular weight cut-off of the membranes based on the sieving curves using polyethylene glycol as a test solute. The estimated pore diameters (pore sizes) for the TAMI 50 kD, 150 kD and 300 kD membranes are 16 nm, 28 nm and 34 nm, respectively. For these membranes and the 70 nm pore size membrane, the 0.18 micron diameter particles found in synthetic bilge water were totally excluded from the membrane pores. Backflushing was applied to both types of larger pore size membranes (0.8 micron and 1.4 micron). The steady-state permeate fluxes for the larger pore KOCH carbon membrane were found to be higher than those of the TAMI membranes. However, the lower pore sized TAMI membranes had a better performance than the carbon membranes.

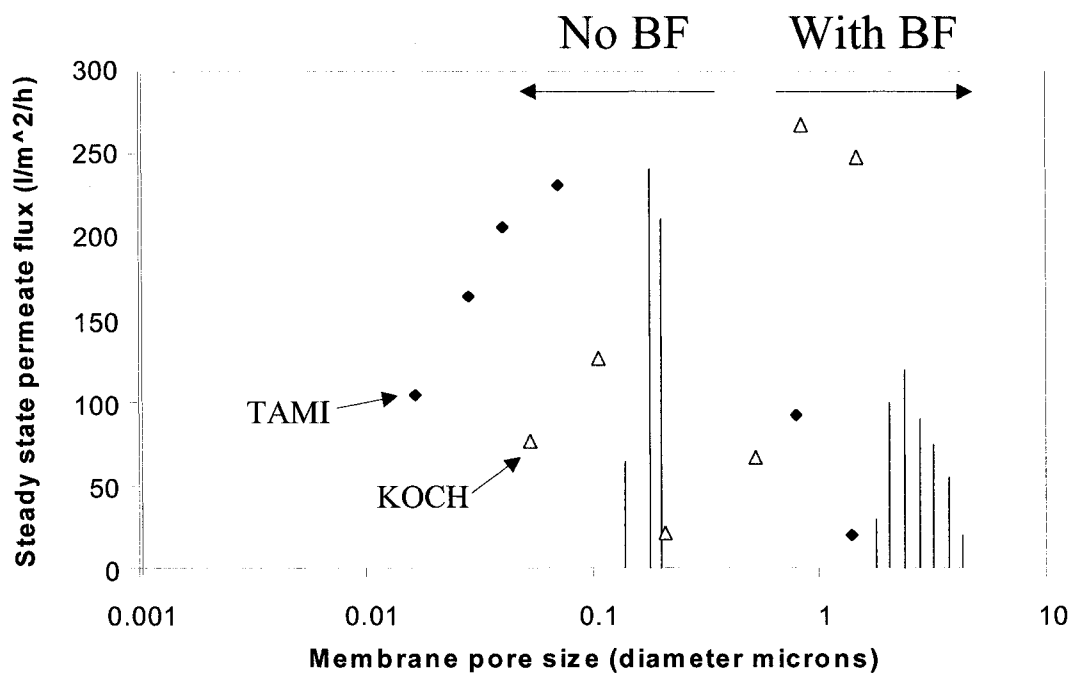

Figure 5: Plot of steady-state permeate flux vs. membrane pore size for the various TAMI ceramic and KOCH carbon membranes (TMP=14.67 psig, 35°C).

3.2 Effect of backflushing

3.2.1 Backflushing vs. no backflushing for KOCH carbon membranes

Tests using the KOCH carbon membranes with backflushing and without backflushing were performed. These tests were performed in the experimental set-up shown in the MF/UF hybrid system (Figure 1) without the UF loop. Permeate production was calculated by integrating the flux vs. time curve over a 24 hour period. Results are shown in Figure 6 below. Results for the 0.05 and 0.1 micron membranes were obtained at a trans-membrane pressure (TMP) of 1.72 barg (25 psig) while those for the 0.8 and 1.4 micron membranes were produced at a TMP of 0.34 barg (5 psig). As seen in Figure 6, with backflushing, the permeate production was 5-8 times more than that without backflushing. The results also indicate that in the absence of backflushing, membrane productivity is relatively independent of pore size and is dominated by the gel layer at the surface of the membrane.

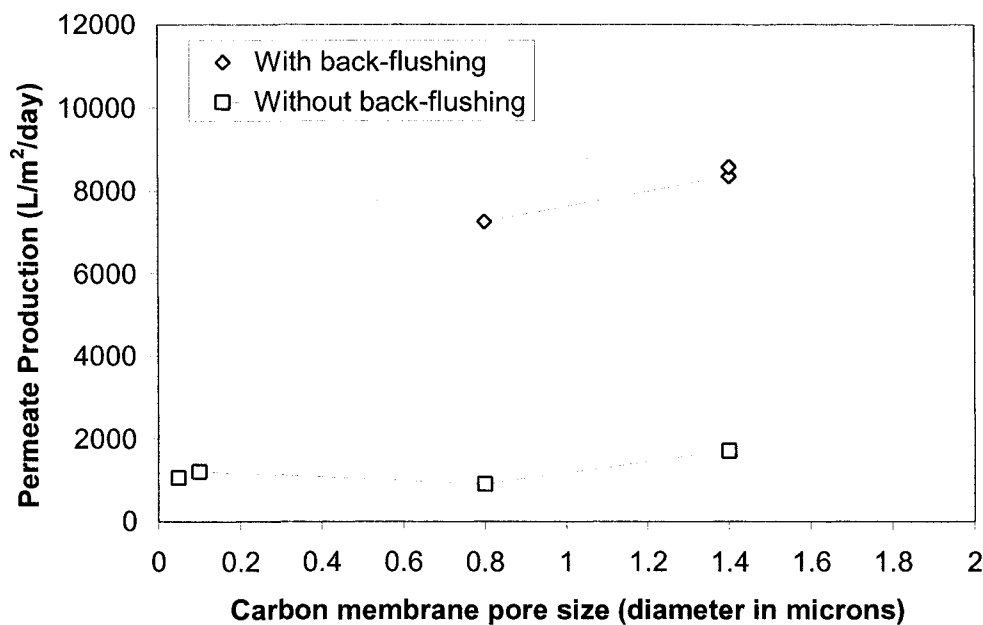

Figure 6: Permeate production/m²/day vs. membrane pore diameter. Backflushing runs were performed using the MF/UF hybrid system (Backflush using UF permeate, effective backflushing TMP=2.41 barg (35 psig), for 3 sec/ 5 min, based on newly prepared bilge water containing 4 g/l of O & G + detergents).

3.2.2 Effect of backflushing frequency

Backflushing frequency is an important factor affecting membrane performance when using backflushing technology. Three different backflush times were tested using the carbon 1.4 micron pore size membrane to investigate the influence of backflushing frequency for the treatment of synthetic bilge water:

- i) BT 297-3 (Backflushing Tests with forward filtration 297 seconds, then reverse filtration 3 seconds), backflushing time 1% of the full cycle;
- ii) BT 294-6 (Backflushing Tests with forward filtration 294 seconds, then reverse filtration 6 seconds), backflushing time 2% of the full cycle; and
- iii) BT 895-5 (Backflushing Tests with forward filtration 895 seconds, then reverse filtration 5 seconds), backflushing time 0.56% of the full cycle.

The 1.4 micron membrane was cleaned prior to the 2-3 day test. It was not cleaned during the test. Results are shown in Figure 7 below. A steep flux decline was found when the backflushing time was 895-5. This indicates that the forward filtration time is too long or the reverse filtration time is too short for the permeate to remove the particles accumulated on and within the membrane. With a backflushing time of 1% and 2% of the full cycle, flux declined gradually to higher steady-state levels. Forward filtration 297 seconds, then reverse filtration for 3 seconds was found to be the best backflushing cycle for the treatment of bilge water.

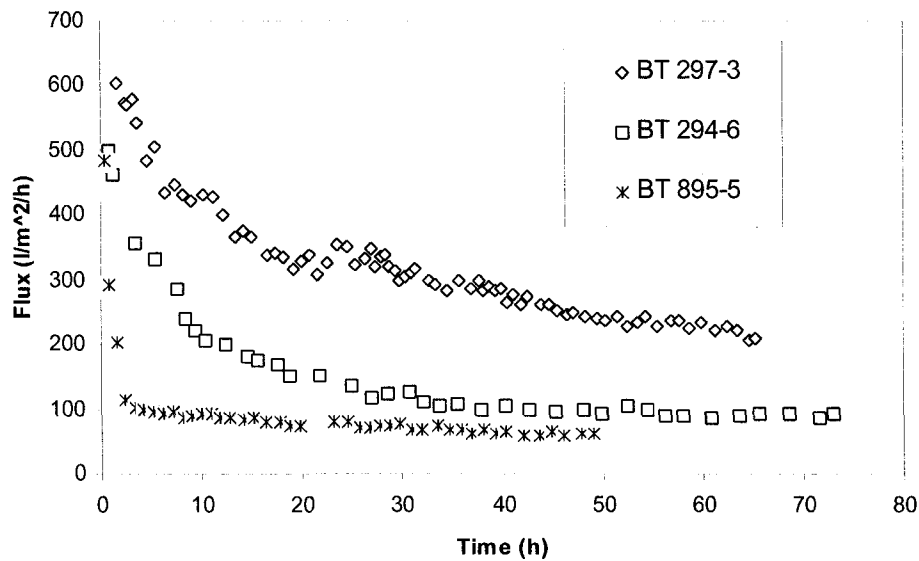

Figure 7: Plot of flux vs. time for the KOCH carbon 1.4 micron membrane with different backflushing time (TMP=5 psig, 35°C, backflushing pressure 35 psig).

3.2.3 Effect of trans-membrane pressure on different types of membranes

In order to compare the performance of the single tube and multilumen membranes when applying backflushing, two runs were conducted using the TAMI 1.4 micron membrane and the KOCH carbon 1.4 micron membrane under the same operating conditions. Experimental results from these runs have been plotted in Figure 8 below. The results clearly show that the effect of backflushing and TMP are different for different types of membranes. Increasing the TMP had little effect on the performance of the multilumen 1.4 micron ceramic membrane but had a significant effect on the single tube 1.4 micron membrane. By increasing TMP, the permeate flux of the KOCH carbon 1.4 micron membrane increased dramatically and could be easily maintained at 150 L/m²/h or higher.

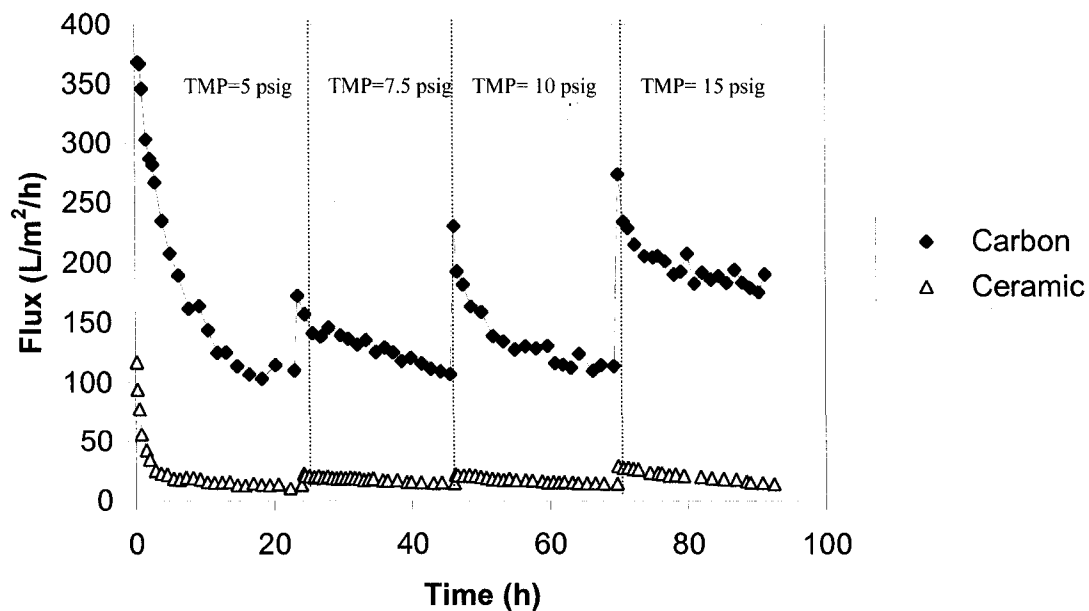

Figure 8: Plot of flux vs. time for the single tube carbon 1.4 micron membrane and the multilumen ceramic 1.4 micron membrane for different TMPs (No cleaning between pressure adjustments, both membranes were backflushed for 3 seconds out of a 5 minutes cycle at 35 psig, 35°C).

The results indicate that these major differences that can be attributed to the support structure of these membranes. The different support structures of the two membranes are shown in Figure 9 below. Both membranes are reported to have 1.4 micron pore size but their support structures are different. In the single tube KOCH carbon membrane, the 1.4 micron selective layer is deposited onto a 10 to 14 micron pore size support. This construction provides excellent clearance, as particles entering the support layer travel a short distance before exiting and the possibility of particle entrapment is reduced. The TAMI membrane is a multilumen membrane with a complex support. The pore size of the support is not known. The clearance for this membrane is lower than the carbon membrane. Sub 1.4 micron particles passing through the selective layer of the membrane must travel through the supporting bridges of the star shaped tube before leaving the membrane. This leads to a substantial accumulation of the particles in the support and reduces the permeate flux. The arrows in Figure 9 indicate paths for the particles during the permeation run. Only the outer circular area of the membrane offers good clearance while clearance for the

remaining area is rather poor. The passage of soot containing particulates in the multilumen membrane is easily seen in Figure 10 where the 1.4 micron membrane has seen considerable particulate passage while this is not seen in the UF membranes. The support used in the multilumen membrane would not be recommended in a backflushing operation to treat this wastewater. This indicates a need for microfiltration membranes having a very open structure that can clear particulates once they pass through the selective layer of the MF membranes. In this pretreatment application, good clearance is required in both the forward and reverse flow directions.

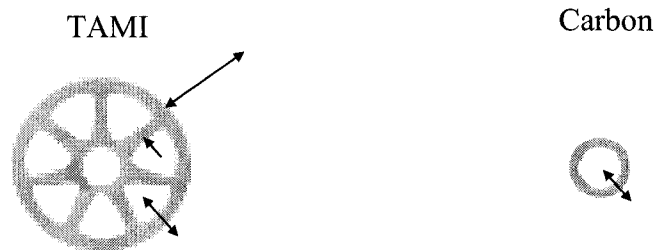

Figure 9: Different support structure of the TAMI ceramic and KOCH carbon membranes.

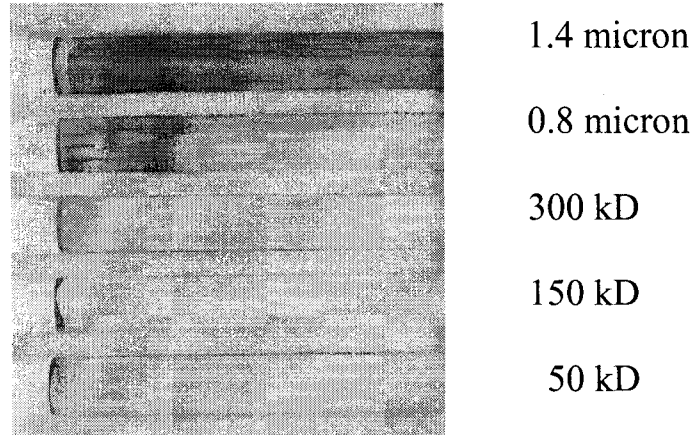

Figure 10: Exterior of the multilumen TAMI ceramic membrane at the end of this study.

3.3 Oil and grease content of the permeate

Table 4 shows the results for the KOCH membranes. These results are based on the original two loop design where feed is first fed to the MF membrane and the permeate treated by a UF membrane. The base case XM 50 data in the first row of Table 4 is for the case where the wastewater is in direct contact with the XM 50 hollow fiber membrane. This represents a feed concentration for the UF membrane of 4 g/L of oil and grease (O & G). The second and third rows of this table contain the results of a MF/UF cascade as shown in Figure 1. The second row contains the analysis for the MF permeate. This permeate was fed to the UF loop and the UF permeate reported in the third row. The results indicate excellent separation for the cascading loop configuration providing 12 times the reduction of oil and grease in the permeate.

Table 4: Oil and grease recovery and rejection of the KOCH Carbon 1.4 micron membrane in a MF/UF hybrid system. Base case is for the UF membrane exposed directly to the feed solution containing 4 g/L of O & G.

Membrane	Recovery of oil & grease (mg/L)
XM 50 (Base case UF loop exposed to 4 g/l O & G)	6.4±0.5
Carbo-cor 1.4 micron (MF loop)	21.9±0.5
XM 50 (UF loop containing MF permeate)	0.53±0.5

The oil and greased content of permeates produced by the TAMI Céram 50 kD, 150 kD, 300 kD, 70nm and 0.8 micron are all below the discharge regulation of 15 mg/L oil and grease in this study. The oil and grease content of bilge water was determined at the beginning and end of a batch concentration run. As seen in Figure 11, even at very high levels of feed concentration (100 g/L), the concentration of O & G in the permeates were still much lower than the allowable discharge limit. These results show that the TAMI ceramic membranes have excellent oil/grease rejection, producing permeate that can be readily discharged overboard in coastal waters.

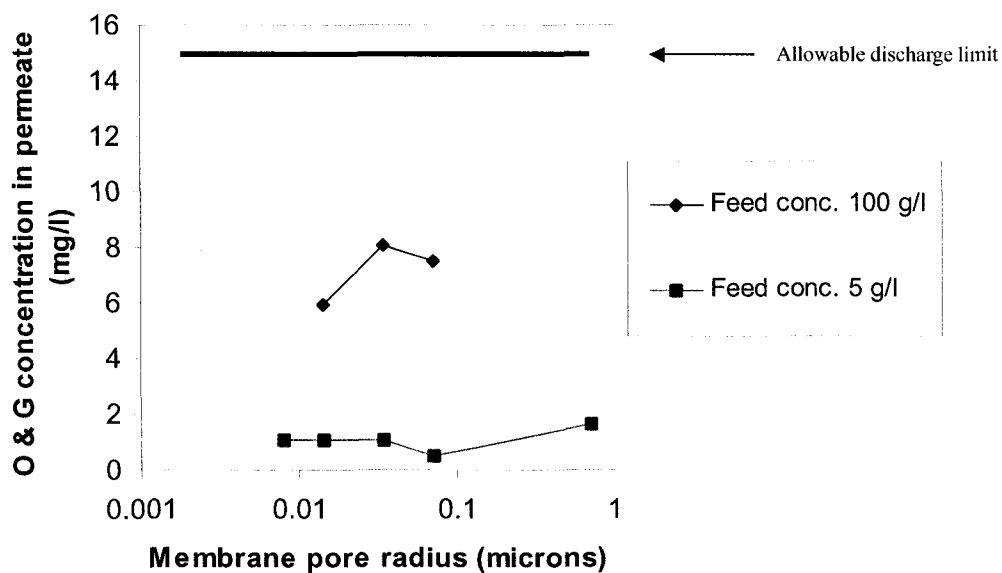

Figure 11: Plot of O & G concentration vs. membrane pore radius for the TAMI membranes.

4. Conclusions

Membranes with a 0.2 micron pore size are not suitable in treating oily brine containing seawater due to the presence of 0.18 micron particles found in this wastewater. Backflushing is an effective technique to reduce fouling caused by “sticky” cakes in synthetic bilge water treatment using a microfiltration membrane. Backflushing offered flux improvements for single tube carbon membranes but not for multilumen ceramic membranes. Membrane support structure was found to be critical in enhancing flux during backflushing. Ceramic membranes with pore size less than 70 nm and backflushed single tube carbon membranes with pore size 1.4 microns followed by UF membrane had the best performance. The optimal backflushing cycle was obtained when flow was reversed for 1 % of the time during a 5 minute period. MF/UF hybrid membrane system was found to be effective in further reducing the oil and grease content of the final permeate by a factor of 12 compared to the case without ultrafiltration. In all cases, after treatment with UF membranes, the oil and grease content of the permeate was found to be below the allowable discharge limit for coastal waters.

Acknowledgements

The authors gratefully acknowledge the financial support of Defence R&D Canada-Atlantic (DREA).

References

- [1] D. Bhattacharyya, A.B. Jumawan, R.B. Grieves and L.R. Harris, Ultrafiltration characteristics of oil-detergent-water systems: membrane fouling mechanisms, *Separ. Sci. Technol.*, 14(6) (1979) 529-549.
- [2] L.J. Zeman and A.L. Zydney, *Microfiltration and Ultrafiltration, Principles and Applications*. Marcel Dekker, Inc., 1996.

- [3] M. Cheryan and N. Rajagopalan, Membrane processing of oily streams: wastewater treatment and waste reduction, *J. Membr. Sci.*, 151 (1998) 13-28.
- [4] M. Cheryan, *Ultrafiltration Handbook*. Technomic Publishing Company, Lancaster, Pennsylvania, USA, 1986.
- [5] E. Lipp, C.H. Lee, A.G. Fane and C.J.D. Fell, A fundamental study of the ultrafiltration of oil-water emulsions, *J. Membr. Sci.*, 36 (1988) 161-177.
- [6] S.H. Hyun and G.T. Kim, Synthesis of ceramic microfiltration membrane for oil/water separation, *Separ. Sci. Technol.*, 32(18) (1997) 2927-2943.
- [7] J. Mueller, Y. Cen and R.H. Davis, Crossflow microfiltration of oily water, *J. Membr. Sci.*, 129 (1997) 221-235.
- [8] J. Ting and J. Wu, Cross-flow ultrafiltration of oil/water emulsions using porous ceramic membranes, *J. Chinese Inst. of Chemical Engineers*, 30 (1999) 207-214.
- [9] J. Kong and K. Li, Oil removal from oil-in-water emulsions using PVDF membranes, *Separ. Purif. Technol.*, 16 (1999) 83-93.
- [10] V.G.J. Rodgers and R.E. Sparks, Effect of transmembrane pressure pulsing on concentration polarization, *J. Membr. Sci.*, 68 (1992) 149-168.
- [11] S. Vigneswame, S. Boonthanon and H. Prasanthi, Filtration backwash recycling using crossflow microfiltration, *Desalination*, 106 (1996) 31-38.
- [12] P. Srijaroonrat, E. Julien and Y. Aurelle, Unstable secondary oil/water emulsion treatment using ultrafiltration: fouling control by backflushing, *J. Membr. Sci.*, 159(1) (1999) 11-20.

- [13] J.A. Ramirez and R.H. Davis, Application of crossflow microfiltration with rapid backpulsing to wastewater treatment, *J. Hazard. Mater.*, B:36 (1998) 179-197.
- [14] J.A. Levesley and M. Hoare, The effect of high frequency backflushing on the microfiltration of yeast homogenate suspensions for the recovery of soluble proteins, *J. Membr. Sci.*, 158 (1999) 29-39.
- [15] R. Sondhi, Y.S. Lin and F. Alvarez, Crossflow filtration of chromium hydroxide suspension by ceramic membranes: fouling and its minimization by backpulsing, *J. Membr. Sci.*, 174 (2000) 111-122.
- [16] V.T. Kuberkar and R.H. Davis, Microfiltration of protein-cell mixtures with crossflushing or backflushing, *J. Membr. Sci.*, 183 (2001) 1-14.
- [17] M. Nottegar and A.Y. Tremblay, Bilge Water Membrane Treatment Phenomena Study, Contract W7707-7-5321, Report for Department of National Defence (DND), Department of Chemical Engineering, University of Ottawa, Canada, 2000.
- [18] Department of National Defence (DND), Technical Statement of Requirements for an Oily Water Separator System, Ottawa, Canada, July 1996.
- [19] ASTM D1141-90, Standard Specification for Substitute Ocean Water, *Dod Index of Specifications and Standards*, Canada, November 1992.

CHAPTER III

The selective removal of oil from wastewaters while minimizing concentrate production using a membrane cascade.

H. Peng, A.Y. Tremblay*

*University of Ottawa, Department of Chemical Engineering
Ottawa, ON, Canada*

*Corresponding author

André Y. Tremblay

Tel.: +1-613-562-5800 ext. 6108; Fax: +1-613-562-5172

E-mail address: tremblay@uottawa.ca

Article has been accepted for publication in **Desalination, October 2007.**

CHAPTER III (Paper 2)

The selective removal of oil from wastewaters while minimizing concentrate production using a membrane cascade.

H. Peng, A.Y. Tremblay*

*University of Ottawa, Department of Chemical Engineering
Ottawa, ON, Canada*

*Corresponding author. 
E-mail address

Abstract

This paper describes the results of a study aimed at removing oil and grease from bilge water accumulating in the lower recesses of ships. Bilge water is a difficult wastewater to treat as it contains seawater, particulates, used oils and detergents. The objective of this work was to design a membrane system that minimized the production of brine retentate waters that must be stored onboard a ship. A pilot scale membrane cascade system was designed and evaluated in this work using tubular MF and UF membranes in a first stage, where high levels of particulate matter are present, and Sepa® flow cells representing spiral wound modules in the second stage. Large channel MF and UF ceramic membranes were used in the first loop while a variety of flat sheet UF (1 to 100 kD MWCO) and NF membranes were studied in the second stage (loop 2). Permeates obtained from the first and second stages were analyzed using an extraction procedure followed by gas chromatography. It was found that lower MWCO membranes (1–5 kD) had excellent permeate fluxes ranging from 25 to 62 L/m²/h and rejections rates of hexane extractable organics were above 90%. The hexane extractable oil and grease concentrations in the permeates from these membranes were found to be 0.1 and 0.0 ppm for the corresponding 1, and 2 kD MWCO membranes. The size of oil particles in the second loop was measured by dispersive light scattering (DLS). Nano sized particles were observed and the size of these particles was found to increase over time as a result of mixing and circulating in the second loop.

Keywords: Membrane; MWCO; Oil and grease; Permeate flux; Oily wastewater

1. Introduction

1.1 Problem definition

There is a need to develop better technology to treat wastewaters containing oils and greases prior to their release in sensitive environments. One particular waste is that of oily brines found in bilges of ocean going vessels. These are very challenging to treat due to the diverse and changing composition of such wastewaters onboard ships. Oily water separators (OWS) are usually used to treat bilge waters prior to discharge. Recently membrane based OWS have been identified as a key technology for the treatment of bilge water onboard ships. Many issues must be considered in the ship-born application of membrane based OWS such as; the proper treatment of the oily brine before discharge, the substantial volume reductions needed, the complexity of the technology, labour associated with the operation of the system due to filter changes and cleaning, and system automation to simplify its operation.

1.2 Membrane processes for oily wastewater treatment

Membrane technologies provide a barrier between the wastewater and effluent, which reduces the possibility of accidental spills due to overflowing oil flotation equipment. Membrane technologies offer substantial advantages over systems based on flotation where equipment malfunction or operator error can cause the waste to bypass the treatment system and contaminate the environment. Membrane ultrafiltration (UF) has been identified as a key technology in the treatment of oily wastewaters [1]. Microfiltration (MF) membranes with a pore size of 0.1 μm were found to be effective in the separation of oily wastewaters and the recovery of surfactant in the feed [2]. Nanofiltration (NF) technology is widely used for the separation of oil and organic matter from aqueous streams [3-5].

1.3 Membrane hybrid system

Applications of membrane hybrid system, such as conventional treatment followed by membrane filtration, or dual membrane systems, offers the potential to reach very low discharge levels. Camp [6] reported that the application of UF offered a good

pretreatment for RO in surface water treatment. A study performed by Lozier and Jones [7] showed that in drinking water treatment using a MF/NF hybrid system, the MF membranes were very effective in reducing particulate fouling of the NF membranes. Chellam et al. [8] investigated the effect of MF and UF pretreatment on surface water by nanofiltration using an integrated pilot-scale membrane system. They concluded that MF and UF pretreatment resulted in lower NF fouling rates and longer cleaning intervals compared with those measured following conventional treatment.

Vigneswaran et al. [9] studied the removal of organics from secondary sewage effluent from a sewage treatment plant using a submerged hollow-fiber membrane with powdered activated carbon (PAC). In this process, the pollutants (particularly the dissolved organics) are first adsorbed onto PAC, greatly reducing the direct loading of dissolved organic pollutants onto the membrane. The PAC-membrane hybrid system was found to be highly effective in removing organic substances in this application. Seo et al. [10] studied residual organic removal in oil wastewater using a hybrid membrane separation activated sludge process and reported more than 95% removal efficiency. Karakulski et al. [11] conducted a study on the purification of bilge water by a combination of ultrafiltration and photocatalytic processes. The photocatalytic process was found to be very effective for the UF permeate reclamation. Gryta et al. [12] investigated the treatment of oily wastewater using a combination of ultrafiltration (UF) and membrane distillation (MD). In this approach, MD was used as a final purification step. Their findings will be further discussed in section 1.4.

However, transporting and managing adsorbents and other chemicals onboard ships have many disadvantages such as storage, handling, cost, regeneration and disposal. There is limited information in literature using only membranes to treat oily salt water to very low oil concentration levels.

1.4 Bilge water treatment

Early research on bilge water treatment can be found in the 1970s [13]. In recent years, oily bilge water has been treated using gravity based Oily Water Separators

(OWS). OWS systems are based on gravity separation, size separation, chemical affinity separation and flocculation. Some emerging technologies have been developed recently for the treatment of oily bilge water.

In a previous study [14], our laboratory used a MF/UF hybrid membrane system to treat synthetic bilge water. Large channel carbon and ceramic MF membranes were used as a pretreatment step and smaller pore size UF hollow fiber polymeric membranes were used as a final polishing step. The system was found to be effective in reducing oil and grease content of the permeate to below the allowable discharge limit (15 ppm) for coastal waters. The purification of bilge water at the Szczecin-Swinoujscie harbour was performed by Karakulski and co-workers [11] using a combination of ultrafiltration and photocatalytic processes. They employed tubular membranes with MWCO of 70 kD for polyvinyl chloride (PVC) and polyacrylonitrile (PAN) and 100 kD for polyvinylidene fluoride (PVDF) in a laboratory-scale ultrafiltration system. They found that the oil content in the UF permeate was less than 15 ppm. Another study performed by Gryta and co-workers [12] investigated the treatment of oily wastewater using a combination of ultrafiltration (UF) and membrane distillation (MD). A tubular UF module with PVDF membranes and capillary MD module with polypropylene membranes were tested using a typical bilge water without pre-treatment. They reported that the permeate obtained from the UF process generally contained less than 5 ppm of oil.

1.5 Objective of this study

The main objective of this study was to develop a membrane based process for the treatment of bilge water in order to meet ever increasing discharge regulations. In many jurisdictions, the oil and grease discharge level for bilge water is set at 0 ppm or a non-detectable level. A pilot scale membrane cascade system was designed and evaluated in this work. This system will evaluate the use of tubular MF and UF membranes in a first stage, where high levels of particulate matter are present, and more compact flow cells representing spiral wound modules in the second stage. Multilumen ceramic membranes were used in the first stage and Sepa® test cells were used in the

second stage. The Sepa® test cells are an industry standard used to simulate the flow characteristics found in spiral wound membrane modules. They provide representative permeate rates for flat sheet membranes used in the manufacture of spiral wound modules. Optimal membrane pore sizes in the second loop were determined. The separation of oil and grease using different MWCO membranes was also performed.

2. Experimental

2.1 Experimental set-up

A two-loop membrane hybrid system was designed and constructed out of 316 stainless steel. A flow diagram of this system is shown in Figure 1. The first membrane circulation loop was used to generate permeate for further treatment. The second loop has been built to coalesce and treat the permeate using flat sheet membranes. Two Sepa® CF II membrane cells from GE Osmonics (Minnetonka, MN, USA) were purchased and a holder manufactured for the cells. This type of test cell has been available commercially for many years and is now an industry standard. These stainless steel lab scale crossflow membrane filtration cells provide fast and accurate performance data and simulate the flow dynamics of large, commercially available membrane elements [15]. The advantage is that the results can be scaled-up to commercial spiral wound modules having a much larger area.

During the experimental runs, permeate from the first loop was sent to the second loop while concentrate of the first loop was circulated back to feed tank. Four pumps were employed in the system. The first pump (Laing Thermotech Inc., Model SM-1212-STW-26, 1/15 HP, San Diego, CA, USA) acted as a feed pump, feeding oily brine to the first loop. The second pump (WEG, Model B56J-11/00, ½ HP) acted as a circulation pump in the first loop. The third pump was a pressurizing pump to raise the pressure in the second loop. A pneumatic diaphragm pump (ARO, Model PD02P-APS-PTT) was employed for low pressure runs (< 100psig) while a microprocessor dosing pump (Milton Roy, Model A941-351SI, Acton, MA, USA) was used for high pressure runs (100-140psi). A fourth pump (Laing Thermotech Inc., Model SM-1212-STW-26, 1/15 HP, San Diego, CA, USA) circulated fluid in the second

loop. The content of the feed tank was continually mixed to prevent excessive de-phasing of the oily brine. Permeates from the second loop (two cells) were collected in two small 150 mL permeate tanks located above the feed tank. The level in the tank was monitored to determine permeate flowrate. The temperature of the first loop was controlled by a water-cooled coil in the feed tank. A platinum RTD (Resistance Temperature Detector) probe placed in the UF loop provided an accurate measure of the feed temperature. A computer operated ON/OFF pneumatic valve controlled the flow of water through the coil in the tank. Once the temperature in the system reached its set point, the system was able to maintain the temperature of the feed solution to within ± 0.1 °C of the set point.

The temperature, pressure, flux of permeates and retentate were graphically displayed on the PC screen and recorded. LABVIEW (National Instruments, USA) software was used to control the system and acquire data. The dotted line in the flow diagram shows the parts controlled or monitored by the computer.

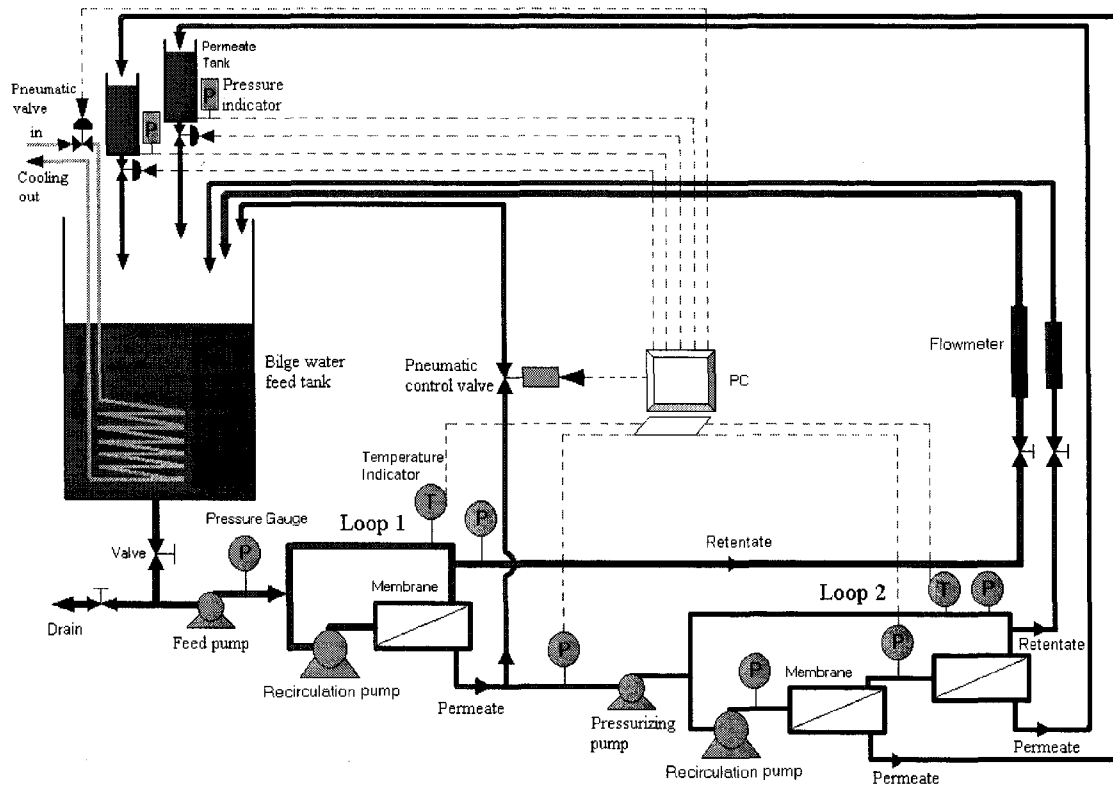

Figure 1: Flow diagram of the two-loop membrane cascade system.

2.2 Membranes

2.2.1 Tubular membranes

TAMI Céram membranes (TAMI Industries, Nyons, France) were used in the first loop. They are multi channel tubular ceramic membranes. These multilumen membranes were purchased as 25 mm OD x 1.2 m long tubes. The characteristics of the membranes tested are listed in Table 1. Two 6 mm channel multilumen membranes were selected for testing. The pore sizes of the 6 mm channel membranes were 0.07 microns (MF) and UF MWCOs of 300 kD. The manufacturer reports a maximum operating temperature of 150 °C, a pH range of 0 to 14, sterilizability, a bursting pressure > 90 barg, and a good range of channel sizes and module packaging.

Table 1: TAMI Céram Membrane Characteristics.

Name	Daisy
Membrane configuration	Tubular
Inside diameter, mm	6
Outside diameter, mm	25
Number of channel	8
Surface area, m ²	0.2
Length, m	1.2
Membranes tested: Pore size (nm) and MWCO (kD)	70 nm and 300 kD

The TAMI ceramic tubular membranes were used in the first treatment step. The selection of these membranes was based on their permeate flux and oil and grease rejection performances in a previous study by Tremblay and Peng [16]. These membranes were reported to have steady-state permeate flux over 100 L/m²/h at a trans-membrane pressure (TMP) of 7.5 psig (0.5 bar) when treating oily brine.

2.2.2 Flat sheet membranes

A full range of commercially available polymeric flat sheet UF and NF membranes from GE Osmonics (Minnetonka, MN, USA) were employed in this study. Information on these membranes is summarized in Table 2.

Table 2: Characteristics of the flat sheet membranes.

Membrane	Designation	Polymer	MWCO (kDaltons)
UF	GH	TF	1
	GK	TF	2
	GM	TF	4
	PT	PES	5
	CQ	CA	20
	JW	PVDF	30
	EW	PS	60
	MW	Ultrafilic	100
NF	CK	CA	0.150*
	DK	TF	0.190 [17]
	DL	TF	0.260 [17]
	HL	TF	0.190 [17]

-TF: Thin Film; PES: Poly (ether sulfones); CA: Cellulose Acetate; PS: Polystyrene;
PVDF: Polyvinylidene fluoride.

* Estimated based on salt rejection.

2.3 Oily brine preparation

In this project, synthetic oily brine was made up from the components as described below (for 1 litre mixture):

- 1) 475 grams fresh water
- 2) 475 grams synthetic sea water
- 3) 5 grams oil
 - i) 50% F76 Naval distillate fuel
 - ii) 20 % lubricating oil NATO 9250 (or MIL-L-9000)
 - iii) 20 % lubricating oil 2190TEP (or ESSO Tromar T77)
 - iv) 10% synthetic lube oil NATO 0156 (or MIL-PRF-23699)
- 4) 500 milligrams surfactant (sodium salt of dodecylbenzenesulfonic acid)
- 5) 500 milligrams carbon black powder (Columbian Chemicals Company)
- 6) 100 milligrams iron III oxide

Reverse Osmosis tap water was used as fresh water. Synthetic seawater was prepared according to ASTM D1141-90: "Standard Specification for Substitute Ocean Water" [18]. This was the basis for the makeup of the standard synthetic oily brine used in our tests. This mixture represented about 5.3 g/L (5,300 ppm) oil and grease in oily brine.

2.4 Analytical

Oil and grease content in membrane permeates was analyzed using n-Hexane liquid-liquid extraction procedure followed by gas chromatography. A Perkin Elmer Gas Chromatography (Perkin Elmer, AutoSystem GC, Wellesley, MA, USA) with a flame ionization detector (GC-FID) was employed in this study.

A nanoparticle sizing apparatus (Malvern Instruments Ltd., Model Nano-S, Worcestershire, UK) was used to characterize feed samples and permeates. The analyzer can determine particle sizes from 0.6 to 6,000 nm.

2.5 Experimental procedure

A test volume of 100 L synthetic oily brine was prepared at room temperature and mixed in the feed tank for several hours before each run. All pilot scale runs were carried out at crossflow rates of 5 to 6 m/s. The duration of a run was normally 20 hours. For each run, the TAMI ceramic membranes were placed in the first loop and two types of flat sheet membranes were put in the two cells. During the tests, the operating pressure was controlled at 30 psig in the first loop and at 30-150 psig in the second loop, depending on different MWCO membranes. The operating temperature was controlled at $30 \pm 0.1^\circ\text{C}$. Feed and permeate samples for each loop were collected for analysis. Permeate flowrates were measured by a level flowmeter which had a high accuracy over the wide range of flowrates usually observed in membrane permeation runs.

Permeate from both loops were sent back to the feed tank during the runs. The retentate flowrate leaving loop 1 was controlled at 12 L/min and that leaving loop 2 controlled to 20-30 mL/min. This represented approximately 10% volume recovery in loop 1 and

80-90% volume recovery in loop 2. The temperature in the feed tank was set to 30 °C. After running for 2 hours, liquid samples of loop 1 feed, loop 1 permeate, loop 2 retentate, cell 1 permeate and cell 2 permeate were collected for O & G analysis. Before a new run, the ceramic membrane module in the first loop was removed from the test system and placed in a separate cleaning system. The membrane was then cleaned as recommended by the manufacturer and thoroughly rinsed with sterilized distilled water. The module was then returned to the test system for a new run. This procedure prevented the contamination of the test loops with cleaning agents.

3. Results and discussion

3.1 Membrane permeation tests

For the TAMI membranes, the operating pressures at the inlet and outlet of the tube were 34 and 15 psig, respectively. The trans-membrane pressure (TMP) was set at 7.5 psig (0.5 bar). For the 60 and 100 kD membranes, the operating pressure was controlled at 30 psig. For the 20 and 30 kD membranes, the operating pressure was controlled at 50 psig. For the 1, 2, 4 and 5 kD membranes, the operating pressure was controlled at 80 psig. For the NF membranes, the operating pressure was controlled at 140 psig. Each run was carried out over a period of 20 hours.

3.1.1 UF tests

TAMI 70 nm membrane was employed in loop 1 of the UF tests. Experimental results are shown in Figure 2 to 4. The permeate flux was normalized to 35 °C since the temperature range was 30-40 °C during most of the runs.

In Figure 2, it can be seen that after 20 hours operation, the flux of the MW membranes was maintained at about 180 L/m²/h while flux of the EW membrane dropped to about 110 L/m²/h. In Figure 3, it was found that permeate fluxes of the JW and CQ membranes reached steady-state levels after 8 hours of operation. The flux of the CQ membrane (78 L/m²/h) was higher than the JW membrane. Figure 4 presents results of the low MWCO UF membranes. It is interesting to note that the steady-state permeate

fluxes of these smaller pore size membranes were maintained at 43-62 L/m²/h during the 20 hour runs except for the 1 kD MWCO GH membrane. Considering these membranes are relatively “tight” UF membranes, permeate fluxes are quite acceptable in this application.

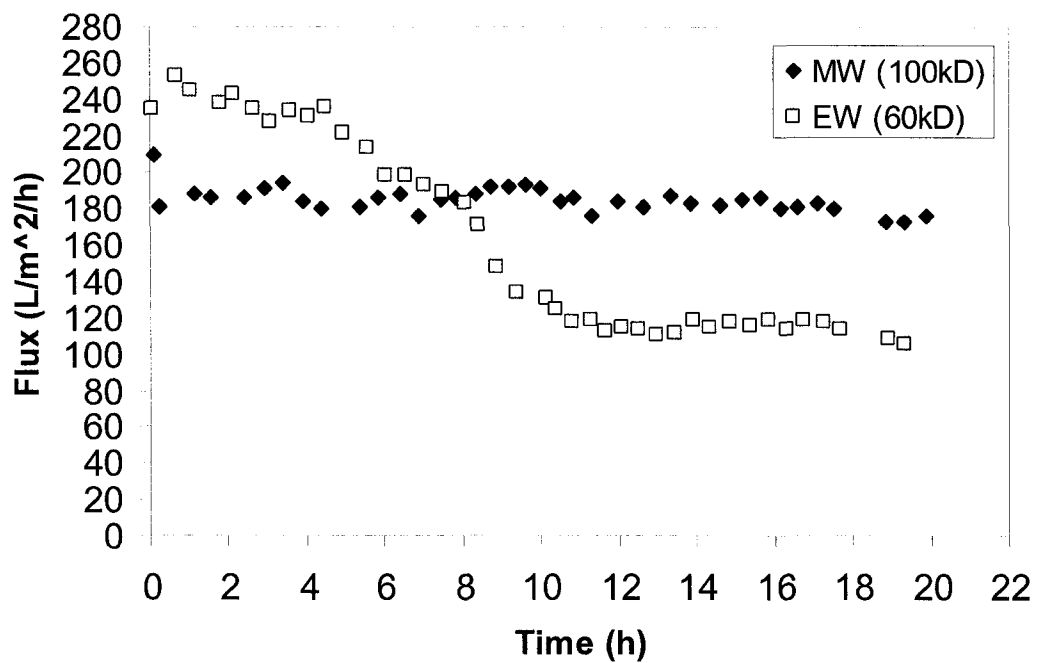

Figure 2: Plot of permeate flux vs. time for the MW and EW membranes (35 °C, operating pressure 30 psig).

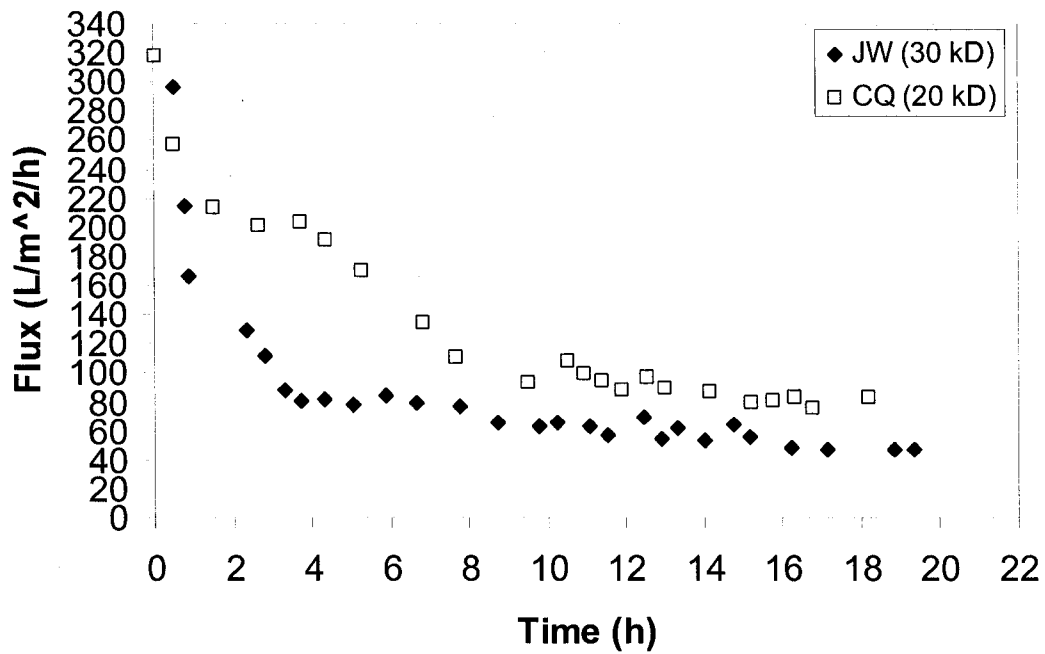

Figure 3: Plot of permeate flux vs. time for the JW and CQ membranes (35 °C, operating pressure 50 psig).

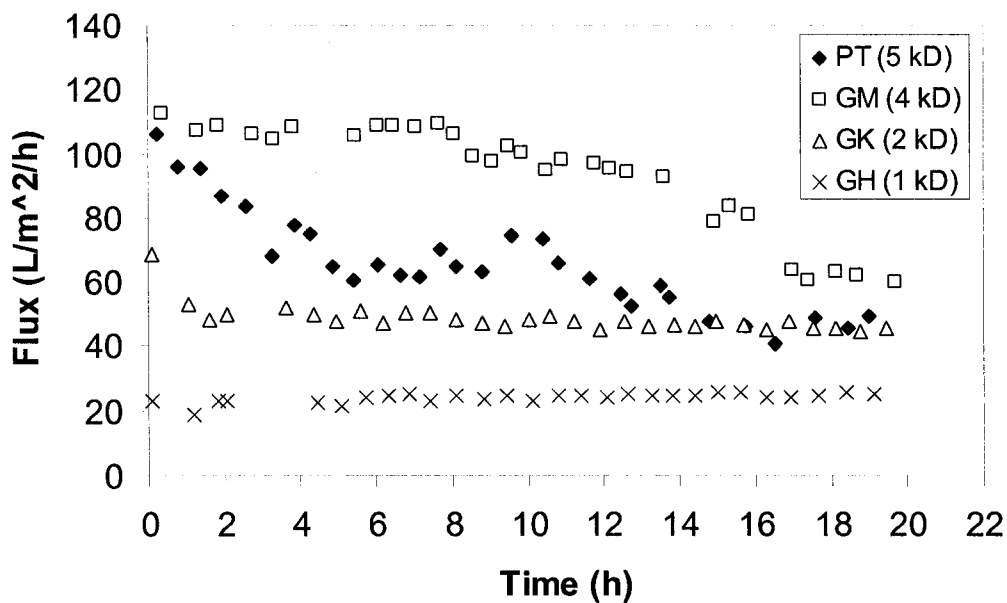

Figure 4: Plot of permeate flux vs. time for the PT, GM, GK, and GH membranes (35 °C, operating pressure 80 psig).

3.1.2 NF tests

The TAMI 300 kD membrane was employed in loop 1 of the NF tests. The NF membranes were tested at 140 psig. It was found that the HL membrane had the highest initial flux while the CK membrane had the lowest initial flux. The fluxes of the DK, DL and HL membranes continued to decline during the 20 hours operation while the flux of the CK membrane reached steady-state after 3 hours operation. At the end of the runs, the fluxes of the CK, DK, DL and HL were found to be 2.2, 5.0, 2.8 and 4.1 L/m²/h, respectively. It was also found that the retentate sample in loop 2 was very cloudy compared to the transparent loop 1 permeate. This visual observation indicated that salts present in the loop 1 permeate were rejected by these NF membranes and accumulated in the retentate stream of the second loop.

The steady-state permeate fluxes of all the membranes after 20 hours operation have been plotted in Figure 5. It can be found that the steady-state fluxes were very low for the membranes with MWCO lower than 1 kD. The steady-state fluxes for the 1, 2, 4 and 5 kD membranes ranged from 25 to 62 L/m²/h. For the membranes with MWCO higher than 5 kD, the steady-state fluxes increased.

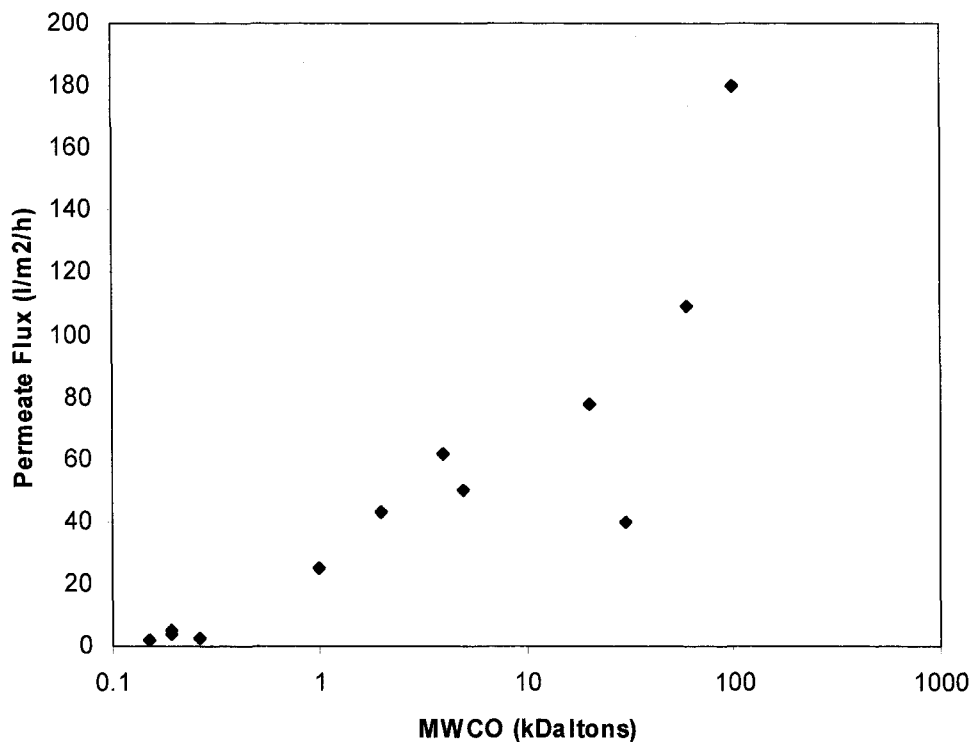

Figure 5: Steady-state permeate flux vs. MWCO for the UF and NF membranes (35 °C).

From Figure 6, it can be seen that the osmotic pressure of the divalent salts present in synthetic bilge water is very close to the 50 psi operating pressure of the ultrafiltration system. In pressure driven membrane separations, the effective driving force across the membrane is limited by the osmotic pressure of the solution to be treated. The retention of divalent salts and concentration polarization at the surface of the NF membrane would increase the salt concentration in the boundary layer by a factor of a subsequent increase could easily explain the reduction in flux experienced by the membranes. Membranes having a MWCO between 1 and 5 kD were not affected by the retention of divalent ions and showed good permeation results.

However, the retention of oil and grease will determine the optimal membrane pore size in this cascade system.

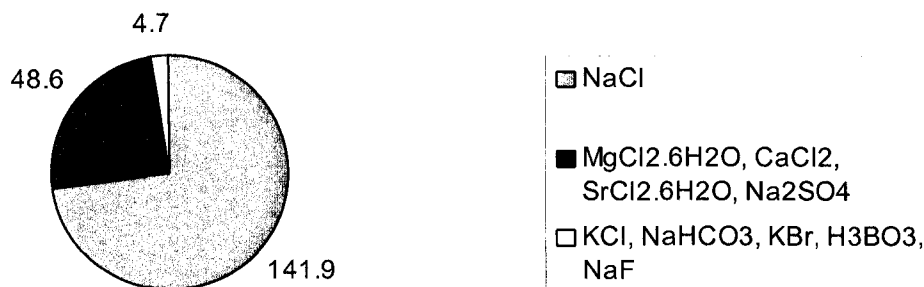

Figure 6: Osmotic pressure (psi) of mono and divalent salts in a solution of 50:50 fresh and synthetic seawater (Synthetic seawater was prepared according to ASTM D1141-90: “Standard Specification for Substitute Ocean Water” [18]).

3.2 Separation of oil and grease

The result of oil and grease concentration for permeates from different MWCO membranes can be found in Figure 7. It was found that after treatment in the first loop using the TAMI 300 kD membrane, the O & G concentration in synthetic bilge water decreased from 1650 ppm to 7.7 ppm with a rejection rate at 99.6%. The permeate from the first loop was used as feed for the second loop. The average O & G concentration in the second loop was determined to be 7.1 ppm. The rejection rates for the higher molecular weight membranes (20 – 100 kD) ranged from 19.7% to 47.9% while much higher rejection rates above 90% were found for the lower molecular weight membranes (1–5 kD). The best rejection rate (100%) was obtained by the 2 kD membrane. Hexane soluble material in the permeate of the 2 kD membrane was non-detectable.

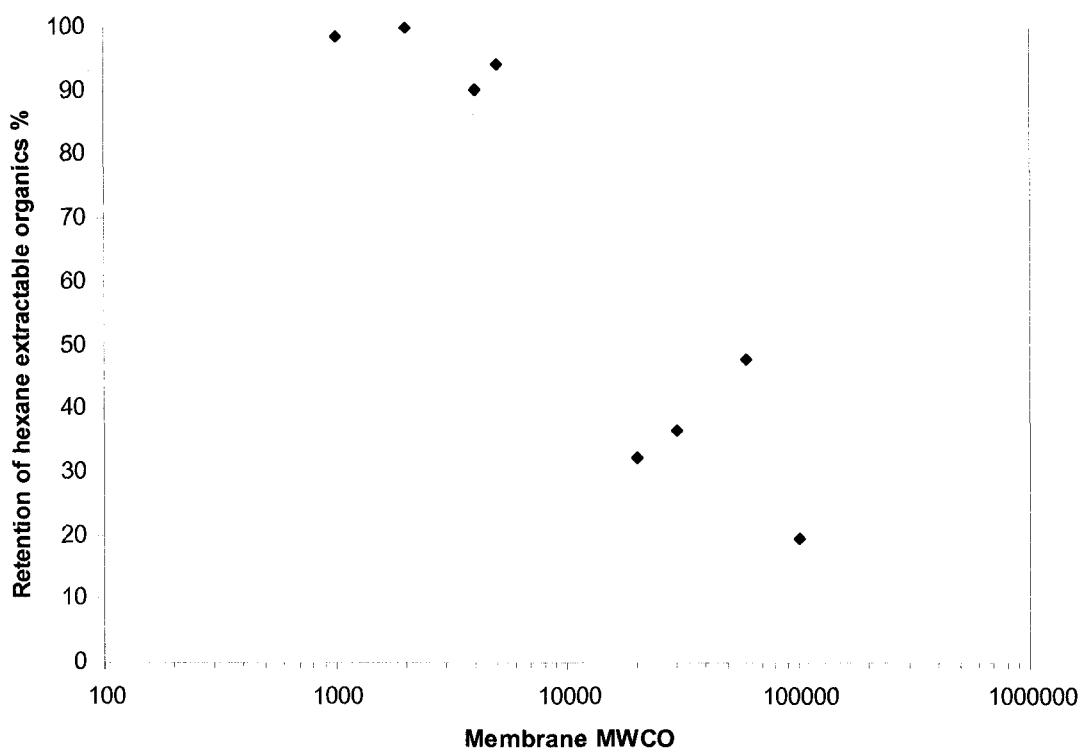

Figure 7: Plot of retention of hexane extractable organics vs. membrane MWCO.

3.3 Particle size measurements

3.3.1 Determination of particle size in synthetic bilge water

Three solutions were prepared for droplet size measurements using the nanoparticle sizing apparatus:

- a) Seawater;
- b) Seawater + oil mixture (5g/L: 50% diesel fuel; 40% lubricating oil MIL-L-9000; 10% synthetic lube oil MIL-PRF-23699).
- c) Seawater + oil mixture (5g/L) + surfactant (0.5g/L: sodium salt of dodecylbenzenesulfonic acid).

The concentrations of the oil mixture and surfactant represent those being defined in the standard bilge water make-up. Results are shown in Figure 8. It was found that the particle size in oily seawater centered around 0.7 μm . When surfactant was added to the oily seawater, the particle size in the mixture increased to about 1.3 μm . These

results indicate that the presence of the surfactant affects the size of the emulsion in bilge water.

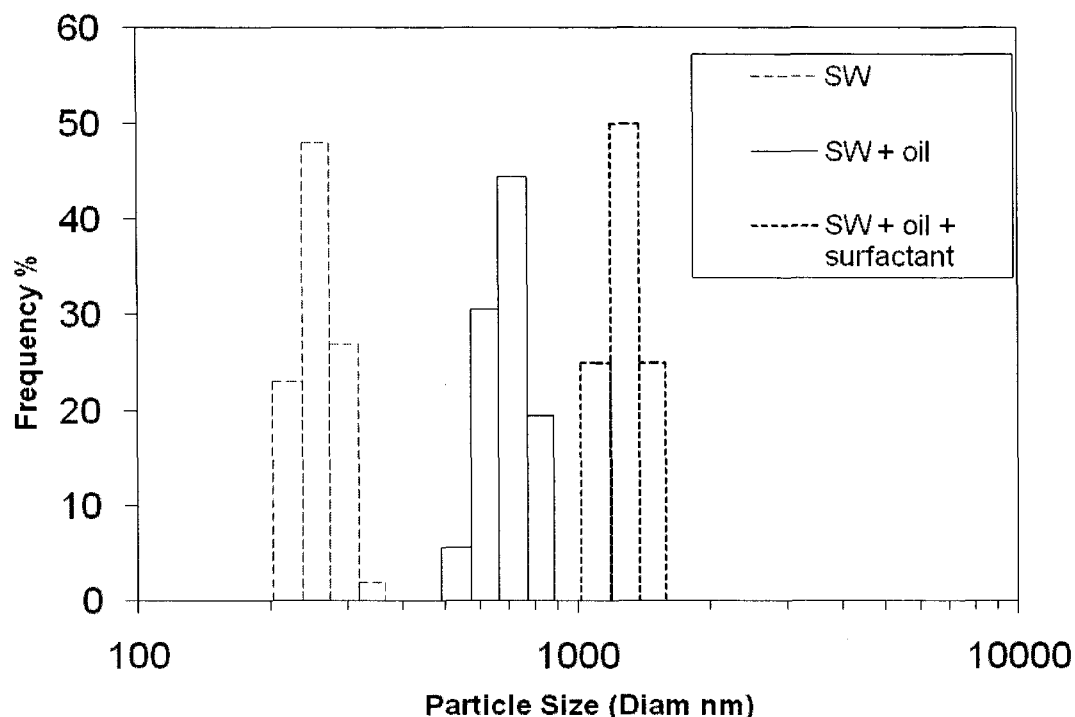

Figure 8: Overlay plot of the particle size distribution in seawater, oily seawater and oily seawater containing surfactant (mixtures a), b) and c) as described above).

3.3.2 Determination of particle size in loop 1 and loop 2

In permeation tests, samples of loop 1 permeate and loop 2 retentate (after 2 hours circulating) were collected for particle size measurements.

Figure 9 shows that particle sizes in loop 2 retentate are bigger than those in loop 1 permeate. Literature search shows that the size of the particles pass through a 300 kD membrane is expected to be approximately 20 nm as calculated by the size of a 300 kD dextran molecule [19]. In this work, the particle sizes in loop 1 permeate (after the 300 kD membrane) were found in the range between 44 and 59 nm, while the particle sizes in loop 2 retentate (circulation loop) were in the range between 106 and 164 nm. This suggests that particle aggregation occurred in the circulation loop. Another run (Figure 10) shows similar results.

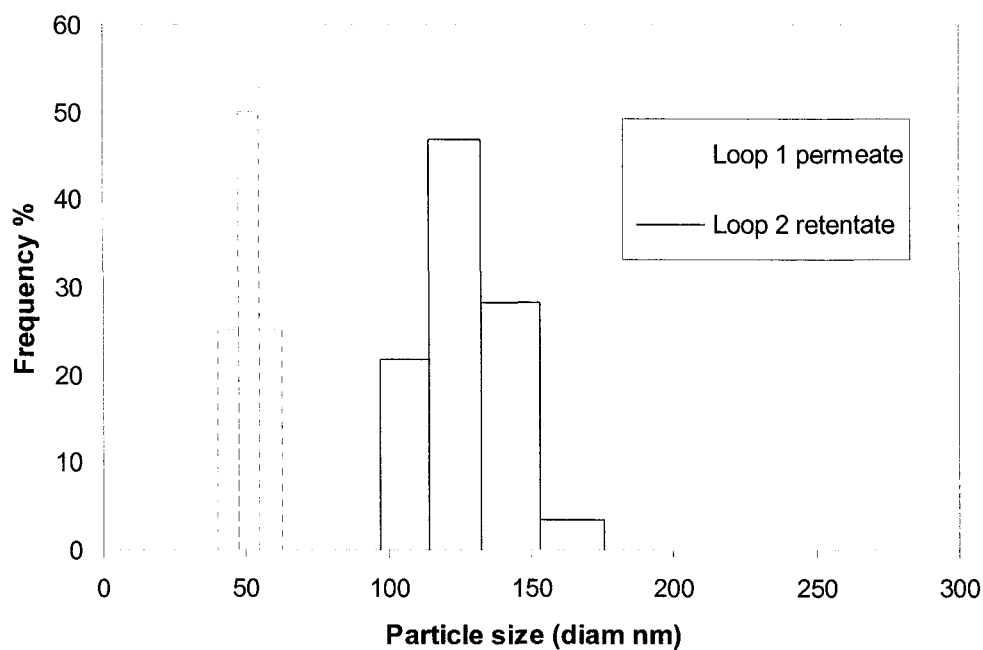

Figure 9: Overlay plot of the particle size distribution in loop 1 permeate and loop 2 retentate (loop 1 membrane: 300 kD TAMI, loop 2 membranes: GH and GK).

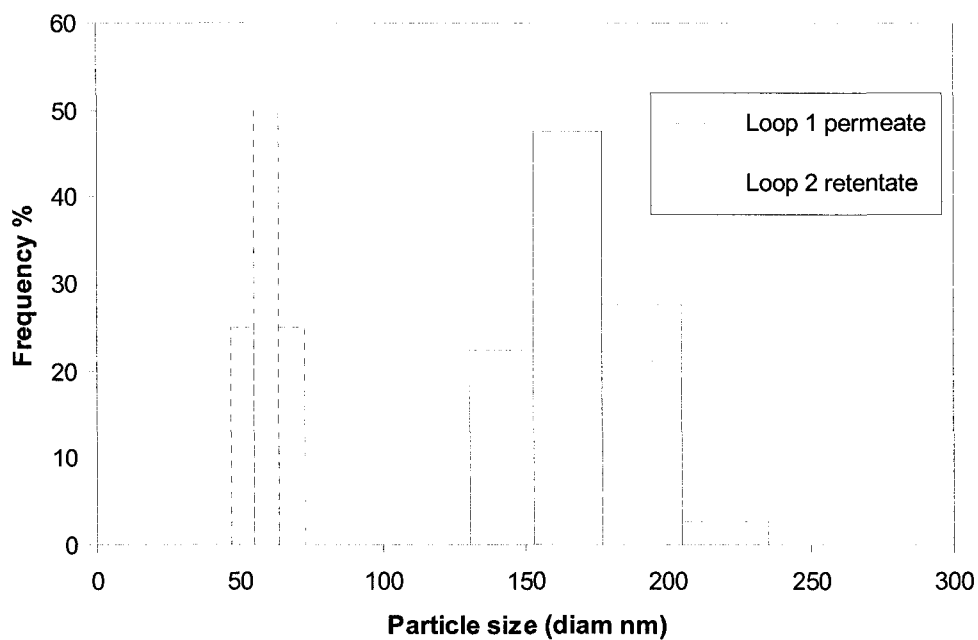

Figure 10: Overlay plot of the particle size distribution in loop 1 permeate and loop 2 retentate (loop 1 membrane: 300 kD TAMI, loop 2 membranes: PT and GM).

4. Conclusions

The objective of this study was to remove oil and grease from bilge water to a level where it could be discharged to sensitive environments using membrane technologies. Results of the research conducted in this study suggest that it is possible to achieve this target through the proper design of the membrane system, selection of appropriate membranes, determination of optimal operating parameters, and assessment of membrane performance.

Specifically, it was found that:

- 1) A pilot-scale membrane cascade system using multilumen tubular ceramic membranes as a first treatment step followed by flat sheet polymeric UF membranes can produce water containing below detectable levels of hexane extractable material.
- 2) The work demonstrated that lower MWCO UF membranes used in the cascade arrangement can retain organics while allowing the passage of mono and divalent salts.
- 3) NF membranes were considered unsuitable in this application due to their retention of divalent salts leading to poor permeate flux performance.
- 4) Higher molecular weight membranes (20–100 kD) were found to have low rejections of hexane extractable material ranging from 47.9% to 19.7%.
- 5) Membranes having lower MWCOs (1–5 kD) had acceptable permeate fluxes ranging from 25 to 62 L/m²/h while maintaining rejections rates of organics above 90%. The oil and grease concentration in the permeates from these membranes were all found to be less than 0.7 ppm ranging from 0.0 to 0.7 ppm.
- 6) Among all the membranes tested in this work, the 2 kD GK membrane was found to have the best performance in the second loop of the cascade system.
- 7) Nano sized particles were observed in membrane permeates. These particles can be aggregated as a result of mixing and concentration in the second loop retentate.

Acknowledgements

The authors gratefully acknowledge the financial support of Defence R&D Canada-Atlantic (DRDC-Atlantic).

References

- [1] L.J. Zeman and A.L.Zydney, Microfiltration and Ultrafiltration, Principles and Applications, Marcel Dekker, Inc., 1996.
- [2] M.Cheryan and N. Rajagopalan, Membrane Processing of Oily Streams: Wastewater Treatment and Waste Reduction, *J. Membr. Sci.*, 151 (1998) 13-28.
- [3] E. Park and S. M. Barnett, Oil/water separation using nanofiltration membrane technology, *Separ. Sci. Technol.*, 36(7) (2001) 1527-1542.
- [4] J.G. Jacangelo, J. DeMarco, D. M.Owen and S. J. Randtke, Selected processes for removing NOM: an overview, *J. Am. Water Works Assoc.*, January (1995) 64-77.
- [5] R. Boussahel, A. Montiel and M. Baudu, Effects of organic and inorganic matter on pesticide rejection by nanofiltration, *Desalination*, 145 (2002)109-114.
- [6] P. Camp, Integral approach of surface water treatment using ultrafiltration and reverse osmosis, proceedings of AWWA membrane technology conference, August 13-16, Reno, Nevada, USA, pp 31-38, 1995.
- [7] J. Lozier and G. Jones, Meeting the challenges of the new drinking water regulations with dual-membrane treatment, proceedings of AWWA membrane technology conference, New Orleans, USA, 1997.
- [8] S. Chellam, J. G. Jacangelo, T.P. Bonacquisti and B.A. Schauer, Effect of pretreatment on surface water nanofiltration, *J. Am. Water Works Assoc.*, October (1997) 77-88.

- [9] S. Vigneswaran, D. S. Chaudhary, H.H. Ngo, W. G. Shim and H. Moon, Application of a PAC-membrane hybrid system for removal of organics from secondary sewage effluent: experiments and modeling, *Separ. Sci. Technol.*, 38 (10) (2003) 2183-2199.
- [10] G.T. Seo, T.S. Lee, B.H. Moon, K.S. Choi and H.D. Lee, Membrane separation activated sludge for residual organic removal in oil wastewater, *Wat. Sci. Tech.*, 36 (12) (1997) 275-282.
- [11] K. Karakuiski, W.A.Morawski and J. Grzechulska, Purification of bilge water by hybrid ultrafiltration and photocatalytic processes, *Separ. Purif. Technol.*, 14 (1998) 163-173.
- [12] M. Gryta, K.Karakulski and A.W.Morawski, Purification of oily wastewater by hybrid UF/MD, *Wat. Res.*, 35 (15) (2001) 3665-3669.
- [13] D.Bhattacharyya, A.B.Jumawan, R.B.Grieves and L.R.Harris, Ultrafiltration Characteristics of Oil-Detergent-Water Systems: Membrane Fouling Mechanisms, *Separ. Sci. Technol.*, 14(6) (1979) 529-549.
- [14] H. Peng, A. Y. Tremblay and D. Veinot, The use of backflushed coalescing microfiltration as a pretreatment for the ultrafiltration of bilge water, *Desalination*, 181 (2005) 109-120.
- [15] GE Osmonics, <http://www.gewater.com/index.jsp>, accessed March 2007.
- [16] A.Y. Tremblay and H. Peng, Bilge water components, pretreatment, and fouling in membrane based oily water separators, contract number W7707-008213/001/HAL, report prepared for Department of National Defence (DND), Ottawa, Canada, 2002.

[17] K. Boussu, B. Van der Bruggen, A. Volodin, C. Van Haesendonckb, J.A. Delcour, P. Van der Meeren and C. Vandecasteele, Characterization of commercial nanofiltration membranes and comparison with self-made polyethersulfone membranes, *Desalination*, 191 (2006) 245-253.

[18] ASTM D1141-90, Standard Specification for Substitute Ocean Water, *Dod Index of Specifications and Standards*, Canada, 1992.

[19] K. Granath and B. Kwist, Molecular Weight Distribution Analysis by Gel Chromatography on Sephadex, *J. Chromatography*, 28 (1967) 69-81.

CHAPTER IV

The analysis of treated bilge water from a combined MF/UF hybrid membrane system.

H. Peng, A.Y. Tremblay*

*University of Ottawa, Department of Chemical Engineering
Ottawa, ON, Canada*

*Corresponding author

André Y. Tremblay

Tel.: +1-613-562-5800 ext. 6108; Fax: +1-613-562-5172

E-mail address: tremblay@uottawa.ca

Article will be submitted for publication.

CHAPTER IV (Paper 3)

The analysis of treated bilge water from a combined MF/UF hybrid membrane system.

H. Peng, A.Y. Tremblay*

*University of Ottawa, Department of Chemical Engineering
Ottawa, ON, Canada*

*Corresponding author. Tel.:
E-mail address:

Abstract

Ships produce oily wastewaters such as bilge water which needs to be treated prior to discharge. Bilge water is a difficult wastewater to treat as it contains seawater, particulates, used oils and detergents. Membrane based oily water separators offer an effective wastewater treatment solution to this environmental discharge problem. This work studied an analytical method for the determination of oil and grease content present in synthetic bilge water. Permeates from a pilot scale Microfiltration (MF)/Ultrafiltration (UF) membrane cascade system were collected and analyzed using an extraction procedure followed by gas chromatography. Experimental results showed that solid phase extraction using ENVI-18 sorbent retained much of the organic matter found in the bilge water and could not preserve the molecular weight distribution in the oil mixture used to prepare synthetic bilge water. n-Hexane liquid-liquid extraction technique was found to be able to preserve the molecular weight distribution in the oil mixture. Possible matrix effects likely caused by the presence of a detergent (sodium salt of dodecylbenzenesulfonic acid) in the synthetic bilge water mixture were studied. It was found that a detergent concentration up to 5 g/L had no effect on the extraction of a 50 ppm diesel and lubricating oil mixture in seawater. Membranes having lower MWCOs (1–5 kD) were found to have rejections for hexane extractable material ranging from 90 to 100%. The oil and grease concentration in the permeates from these membranes were all found to be less than 0.7 ppm ranging from 0.0 to 0.7 ppm. n-Hexane liquid-liquid extraction technique preserved the molecular weight distribution of diesel and lubricating

oils separated by Ultrafiltration. The hybrid system comprising a 300 kD small pore MF membrane and a 2 kD UF membrane was an excellent combination to remove the hexane extractable organics from bilge water to levels below the detection limit.

Keywords: Membrane; MWCO; GC-FID chromatogram; Oil and grease; Oily wastewater

1. Introduction

Interest and activity in the Canadian Arctic have considerably increased during the past decade. In addition to this, the accelerated melting of the polar icecap has opened marine transportation routes in this highly sensitive environment. There is an increasing need to develop effective and inherently safe techniques for the treatment of wastewaters generated by these activities. Ships produce oily wastewaters such as bilge water which needs to be treated prior to discharge. Bilge water is a difficult wastewater to treat as it contains seawater, particulates, used oils and detergents. Normally, the concentration of oil and grease in bilge water ranges from 200 to 2,000 parts per million (ppm). Membrane based oily water separators offer an effective wastewater treatment solution to this environmental discharge problem.

In recent years, considerable attention has been focused on the discharge of oily wastewaters from ships. The IMO (International Maritime Organization) has been the leader in developing discharge regulations for bilge water and other ship-generated pollution [1]. The discharge limit for oily bilge water within coastal waters is recognized internationally as 15 ppm; while within localities, more stringent limits exist. Some previous studies in bilge water treatment using membrane technologies showed that, with proper membrane system design and membrane selection, oil and grease content of the membrane permeate below the allowable discharge limit (15 ppm) can be achieved [2-4].

Several methods are available in the literature for the determination of oil and grease in water. EPA Method 1664 (n-Hexane liquid-liquid extraction) is a method of choice for oil and grease determination in water [5]. The 19th edition of *Standard Methods*

proposed three methods for liquid samples: the partition-gravimetric method, the partition-infrared method and the Soxhlet method [6]. The ASTM method uses solvent (1,1,2-trichloro-1,1,2-trifluoroethane) extraction followed by infrared spectroscopy [7]. Solid phase extraction (SPE) methods and Gas chromatography (GC) methods are also reported in literature. In a previous study, Nottegar and Tremblay [8] used solvent (methanol and hexane) extraction and gravimetry to determine oil and grease concentration in SPE samples. Langenfeld and co-workers [9] reported using solid-phase microextraction (SPME) and GC-FID (Flame Ionization Detector) as a technique for the rapid determination of hydrocarbons in complex water matrices. Saraullo and co-workers [10] developed a simple method using SPME with poly(dimethylsiloxane) fiber coating to quantify petroleum hydrocarbons in water. GC-FID was employed in this study in the oil analysis. Daiminger et al. [11] employed GC-FID for the measurement of residual amount of isododecane in an oil/water separation study. An ISO method describes the analytical procedure for determination of hydrocarbons oil index by solvent extraction and GC-FID [12]. In this method, organic compounds are extracted with a hydrocarbon, whose boiling point is between 36 °C and 69 °C, not adsorbed on Florisil and which may be chromatographed with retention times between those of n-decane ($C_{10}H_{24}$) and n-tetracontane ($C_{40}H_{82}$).

Wang and co-workers [13-16] have conducted extensive research on oil characterization in sediments. They developed a microcolumn fractionation technique using GC/FID and GC/MS. Sediment samples are extracted using hexane and benzene. Half of the hexane fraction (F1) is used for the analysis of saturates and biomarker compounds; half of the 50% benzene fraction (F2) is used for analysis of PAHs and alkylated PAH homologues; the remaining half of F1 and F2 are combined (F3) and used for the determination of Total Petroleum Hydrocarbons (TPH) and the remaining unresolved complex mixture of hydrocarbons. Based on this work, an analytical method including detail procedures of sample extraction and cleanup was developed by Wang [17] for the determination of TPH and oil-spill-related environmental samples by GC/FID and GC/MS.

The literature contains few references regarding the analysis of oil and grease at very low concentration levels from membrane permeates. The establishment of an appropriate analytical method to extract and analyze organic species at very low concentration levels for the analysis of oil and grease content found in bilge water would be very interesting. The EPA and ASTM methods do not provide the needed precision. The GC method appears to be a better choice for this work. The key point for the success of this objective is to select the appropriate extraction technique and identify appropriate parameters for the GC.

2. Experimental

2.1 Bilge water preparation

In this project, synthetic oily brine was made up from the components as described below (for 1 litre mixture):

- 1) 475 grams fresh water
- 2) 475 grams synthetic sea water
- 3) 5 grams oil
 - i) 50% F76 Naval distillate fuel
 - ii) 20 % lubricating oil NATO 9250(or MIL-L-9000)
 - iii) 20 % lubricating oil 2190TEP (or ESSO Tromar T77)
 - iv) 10% synthetic lube oil NATO 0156(or MIL-PRF-23699)
- 4) 500 milligrams surfactant (sodium salt of dodecylbenzenesulfonic acid)
- 5) 500 milligrams carbon black powder
- 6) 100 milligrams iron III oxide

Reverse Osmosis tap water was used as fresh water. Synthetic seawater was prepared according to ASTM D1141-90: "Standard Specification for Substitute Ocean Water" [18]. This was the basis for the makeup of the standard synthetic oily brine used in our tests. This mixture represented about 5.3 g/L (5,300 ppm) oil and grease in oily brine.

2.2 Sample collection

Experiments were conducted using a pilot scale membrane cascade system using tubular MF and UF membranes in a first stage, where high levels of particulate matter are present, and more compact (higher membrane area per unit volume) spiral wound modules in the second stage. Large channel MF and UF ceramic membranes (300 kD MWCO and 70 nm pore size) were used in the first loop while a variety of flat sheet polymeric UF (1 to 100 kD MWCO) and nanofiltration (NF) membranes were studied in the second stage (loop 2). Permeates obtained from the first and second stages were collected and analyzed using an extraction procedure followed by gas chromatography. Liquid samples of loop 1 feed, loop 1 permeate, loop 2 retentate, cell 1 permeate and cell 2 permeate were collected for O & G analysis. Details of the experimental set up, membranes used, and experimental procedure can be found in another paper prepared by our lab earlier [19].

2.3 Solid phase extraction (SPE)

Based on the literature research, the SPE and GC/FID methods appeared to be good choices for the determination of oil and grease. ENVI-18 solid extraction tubes were purchased from SUPELCO (Bellefonte, PA, USA) and used according to manufacturer specifications. This SPE extractant contains fused silica and is suitable for capture of organic compounds. Hexane or Methylene Chloride (DCM) can be used as extraction solvent.

2.4 n-Hexane liquid-liquid extraction

In this method a liquid sample is extracted with n-Hexane and injected into the GC/FID. The steps performed in this method are summarized as follows:

- 1) Collect 1 litre of liquid sample.
- 2) Transfer the liquid sample to a 2 litre separatory funnel.
- 3) Add 40 mL of n-Hexane.
- 4) Shake vigorously for 30 seconds.
- 5) Allow the organic phase (top) to separate for 20 min.
- 6) Drain the bottom phase.

- 7) Collect the organic phase into a 250 mL round bottom flask.
- 8) Rinse the separatory funnel using 10 mL of n-Hexane.
- 9) Collect the 10 mL of n-Hexane into the round bottom flask.
- 10) Rotovap the sample extract to dry.
- 11) Add 2 mL of n-Hexane to the round bottom flask.
- 12) Transfer about 1 mL to a GC vial.
- 13) Load the sample to an Autosampler.
- 14) Run the sequence.
- 15) Printout chromatograms.

2.5 Gas chromatography (GC)

A Perkin Elmer Gas Chromatography (GC) (Perkin Elmer, AutoSystem GC, Wellesley, MA, USA) was donated by Environment Canada and installed in our lab. The instrument was used to analyze all samples in this project. The analysis was performed using the following conditions:

Instrument:	Perkin Elmer, AutoSystem GC	
Column:	30 m x 0.53 mm ID DB-5	
Detector:	FID	
Autosampler:	Perkin Elmer N610-0019	
Gases:	Carrier:	Helium, 30 mL/min, constant flow
	Detector air:	400 mL/min
	Detector hydrogen:	30 mL/min
Injection volume:	4 μ L	
Injector temperature:	290 °C	
Detector temperature:	300 °C	
Temperature program:	50 °C for 2 min, then 6/min to 300 °C, hold 16.7min. The total run time is 60 minutes.	

3. Results and discussion

3.1 Validation of analytical methods

3.1.1 SPE

The SPE packing ENVI-18 (SUPELCO, Bellefonte, PA, USA) was tested to determine its suitability as a solid phase extractant for the recovery of oil and grease from bilge water. The membrane cascade system is illustrated elsewhere [19]. The first loop (loop 1) contains tubular MF membranes while the second loop (loop 2) contains flat sheet UF and NF membranes. For each run, the SPE samples of loop 1 feed, loop 1 permeate, loop 2 retentate, cell 1 permeate and cell 2 permeate were taken by passing a given amount of liquid (60-160 mL) through the SPE tubes. Methylene Chloride (DCM) was used as extraction solvent for the SPE tubes. The sample extracts were then prepared for GC/FID analysis. However, no responses were found in the chromatograms. Injections of several DCM solutions containing diesel revealed that the GC's operation was not at fault. These results indicated that contrary to the manufacturer's specifications, oil was not released from the SPE tubes.

The extraction procedure was repeated for phase separated synthetic bilge water. In this case, bilge water was mixed and allowed to settle for 2 hrs; 500 mL of the bottom phase was passed through the SPE column and then solvent extracted using DCM. The GC barely detected the presence of oil in the extracted phase. This was most likely due to the limited ability of the extraction solvent to remove the organic species sorbed on the SPE packing. Perhaps the use of a reverse phase having a shorter carbon chain (C4 or C8) would have permitted the release of the oil and grease. However, the mixture of diesel and lubricating oil found in bilge water has a range of hydrocarbons from C10 to C34. In addition to this, any SPE would most likely retain the organic species in the mixture to varying extent. This would have meant a loss of a very important aspect of speciation available using gas chromatography as opposed to a more general infrared (IR) detection. In conclusion, the SPE technique was not suitable for the release of oil and grease from diesel and lubricating oil mixtures. It was not acceptable as a concentration technique to characterize a mixture containing a

broad range of molecular weights. This limited the use of this more rapid method in determining the oil and grease content in bilge water.

3.1.2 n-Hexane liquid-liquid extraction

Given the limitations of the SPE method, we decided to revert to the more time consuming method of liquid-liquid extraction using n-Hexane as the extraction solvent. In this method a liquid sample is extracted with n-Hexane and injected into the GC/FID. The results in the following sections are all based on liquid-liquid extraction using n-Hexane as the extraction solvent.

3.2 Oil and grease determination

3.2.1 Chromatogram of standard mixture

In order to identify and quantify the organic species present in bilge water, two standard oil mixtures were purchased from Chromatographic Specialties Inc.: diesel standard (DRO Defining Mix.) and lubricating oil standard (AK103AA PRO Standard). The diesel standard mixture contains alkanes with carbon numbers in the range of C10-C25 while the lubricating oil standard contains alkanes with carbon numbers in the range of C26-C34 and some aromatics. Tests were performed to determine the retention time and concentration of each organic compound using GC/FID. Table 1 shows the retention times and area counts for all the organic compounds found in the standard mixtures identified by GC/FID. The chromatogram results of the two standard mixtures have been overlaid and shown in Figure 1.

Table 1: Characteristics of standard mixtures and GC injection results.

Standard	Component	Carbon number	Peak number (in Fig. 1)	Certified analyte concentration ($\mu\text{g/mL}$)	Retention time (min)
Diesel (DRO Defining Mix.)	n-Decane	10	1	1998	8.860
	n-Undecane	11	2	1965	11.585
	n-Dodecane	12	3	1980	14.216
	n-Tridecane	13	4	1991	16.712
	n-Tetradecane	14	5	1996	19.073
	n-Pentadecane	15	6	1975	21.307
	n-Hexadecane	16	7	1997	23.418
	n-Heptadecane	17	8	2003	25.422
	n-Octadecane	18	9	1985	27.328
	n-Nonadecane	19	10	2001	29.140
	n-Eicosane	20	11	2004	30.865
	n-Heneicosane	21	12	2001	32.522
	n-Docosane	22	13	1994	34.108
	n-Tricosane	23	14	1977	35.623
	n-Tetracosane	24	15	2001	37.080
n-Pentacosane	25	16	1984	38.481	
Lubricating oil (AK103AA PRO)	n-Hexacosane	26		2008	39.810
	n-Octacosane	28		2012	42.360
	n-Triacontane	30		1994	42.943
	n-Dotriacontane	32		2008	44.132
	n-Tetratriacontane	34		1986	44.820
	Benzo(b)fluoranthene			2002	47.950
	Benzo(a)pyrene			1998	49.405
	Benzo(g,h,i)perylene			2004	50.743
Dibenz(a,h)anthracene			2002	52.320	

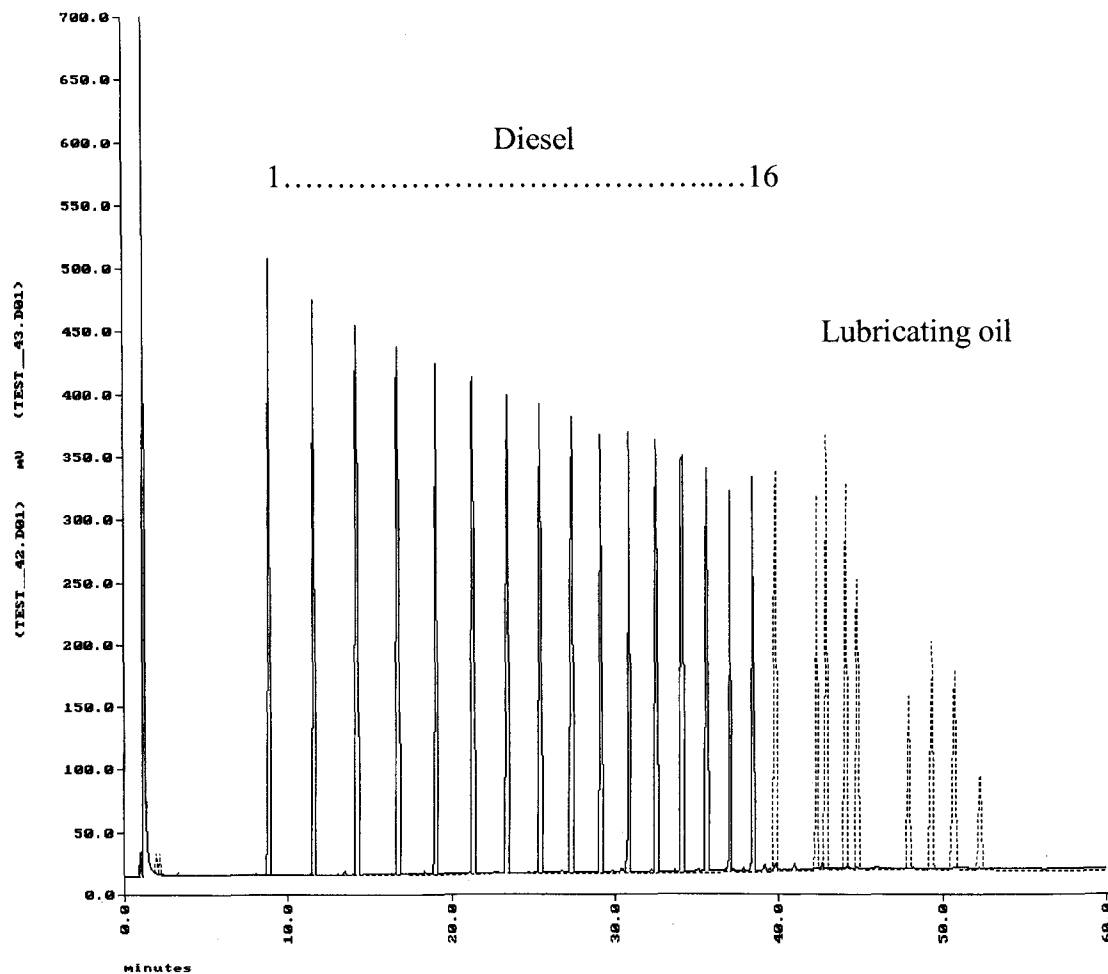

Figure 1: Overlaid plot of two injections by GC/FID (Perkin Elmer AutoSystem, solid line is diesel oil, dotted line is lubricating oil).

3.2.2 Chromatograms of oil mixture in bilge water

The oil mixture found in bilge water (50% diesel fuel; 40% lubricating oil MIL-L-9000; 10% synthetic lube oil MIL-PRF-23699) was analyzed using GC/FID. A spiked hexane solution containing 0.100 gr of this oil mixture in 25 mL of pure n-Hexane was injected in the GC. This concentration represents a concentration of 4 mg oil mixture/mL hexane. Four (4) microlitres of this solution was injected into the GC. Injection results are shown in Figure 2.

The same amount of oil 0.100 gr was then added to 2 Litres of seawater. The oil was extracted from the solution using 25 mL of hexane. Four (4) microlitres of the organic phase was injected into the GC. The chromatograph shown in Figure 3 was obtained.

By comparing Figures 2 and 3, it can be seen that hexane extraction can retain the molecular weight distribution of the oils present in solution as the ration of the diesel to lubricating oils in both plots are visually the same. The concentration of the extracted organic phase was slightly higher than that of the original spiked hexane. This difference was attributed to errors in the sample preparation technique which were later corrected. After these initial trials, it was decided to concentrate the organic hexane phase by evaporation and re-dissolve the organics with a known quantity of hexane prior to injection into the GC.

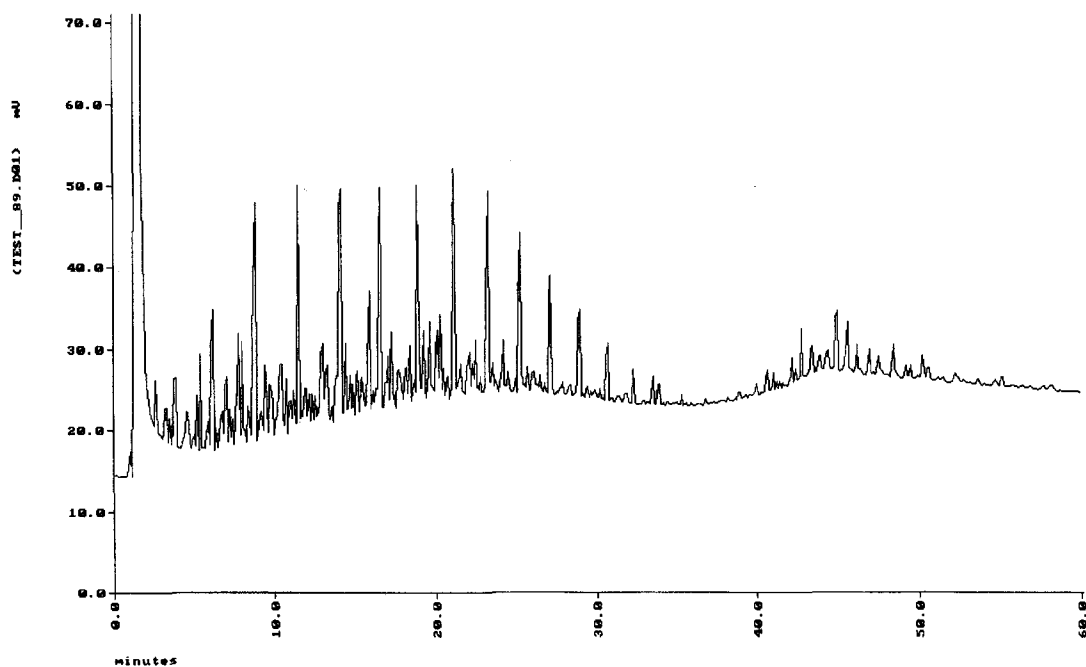

Figure 2: Analysis of oil mixture found in synthetic bilge water. Four (4) microlitre injection of a 4 mg oil mixture / mL of hexane.

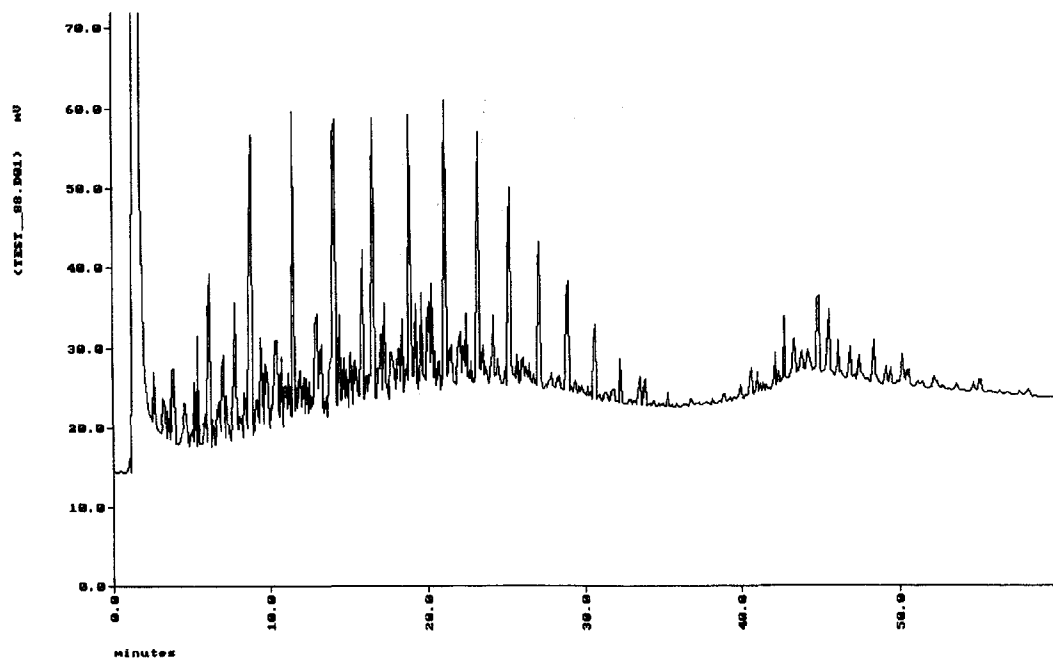

Figure 3: Analysis of oils extracted using 25 mL of hexane from 0.1 gr oil mixture found in synthetic bilge water in 2 L of seawater.

3.3 Effect of surfactant concentration in extraction

Tests were performed to study the effect of surfactant concentration on the solvent extraction process. Seven oil + half seawater samples with different concentrations of surfactant (0, 0.05, 0.1, 0.2, 0.3, 0.4 and 0.5 g/L of sodium salt of dodecylbenzenesulfonic acid) were prepared. Each sample contained 2 litres of seawater and 0.1 gr of oil mixture, which represented 50 ppm oil in the seawater. Twenty five (25) mL of n-Hexane were added to each of these samples for extraction. The sample extracts were then transferred to GC vials for injections. The peak for C10 (n-decane) was selected as a representative peak for the diesel found in the mixture. The areas ($\mu\text{V}\cdot\text{sec}$) of the C10 peaks from a 4 microlitre injection are shown in Figure 4. These results along with those obtained for other molecular weights, show that surfactant concentration does not have a significant impact in the solvent extraction process.

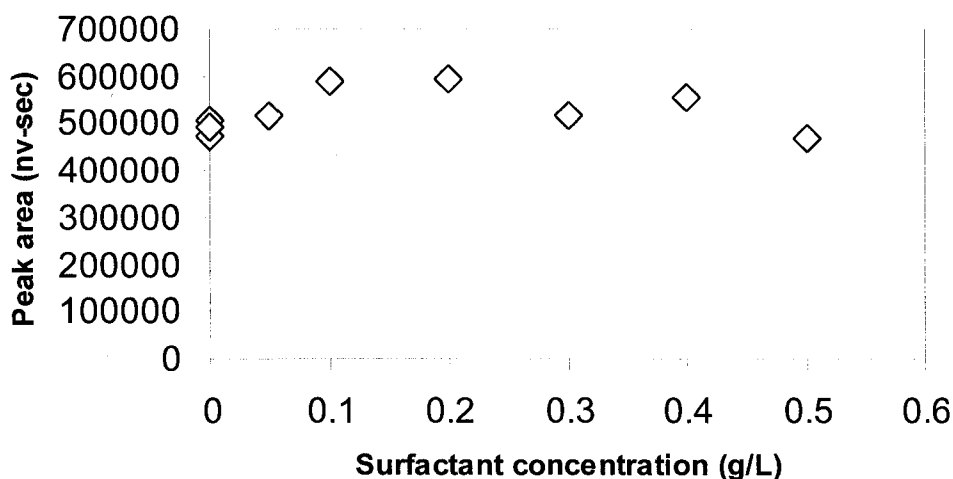

Figure 4: Plot of peak area vs. surfactant concentration for the C10 (n-decane).

In conclusion, the preliminary GC injection results indicate that a matrix effect was not present for dodecylbenzenesulfonate. This made it possible to quantify the organic compounds present in bilge water using GC/FID without knowing the detergent concentration in the sample. These results indicate that n-Hexane liquid-liquid extraction can retain the molecular weight distribution of the diesel fuel found in the oil mixture.

3.4 Determination of oil and grease in treated synthetic bilge water

Experiments were performed using a 300 kD ceramic membrane in the first loop and a variety of membranes in loop 2 ranged from 1 kD MWCO to 20 kD MWCO UF membranes. Permeates from the first and the second loop were collected and contacted with hexane and the hexane soluble material concentrated in a rotary evaporator. Care was taken to provide some degree of reflux in the evaporator in order to prevent the lower molecular weight fractions of diesel from escaping the evaporator. The samples were evaporated to dryness and 2 mL of hexane were added to the sample prior to analysis by GC-FID.

3.4.1 Oil and grease concentration in loop 1 feed

Fifty (50) mL of feed solution in the inlet of the loop 1 membrane (before the 300 kD MWCO membrane) was collected and GC sample was prepared. Chromatogram obtained from GC-FID is shown in Figure 5 below. The oil and grease concentration in loop 1 feed was found to be 1,649.7 ppm.

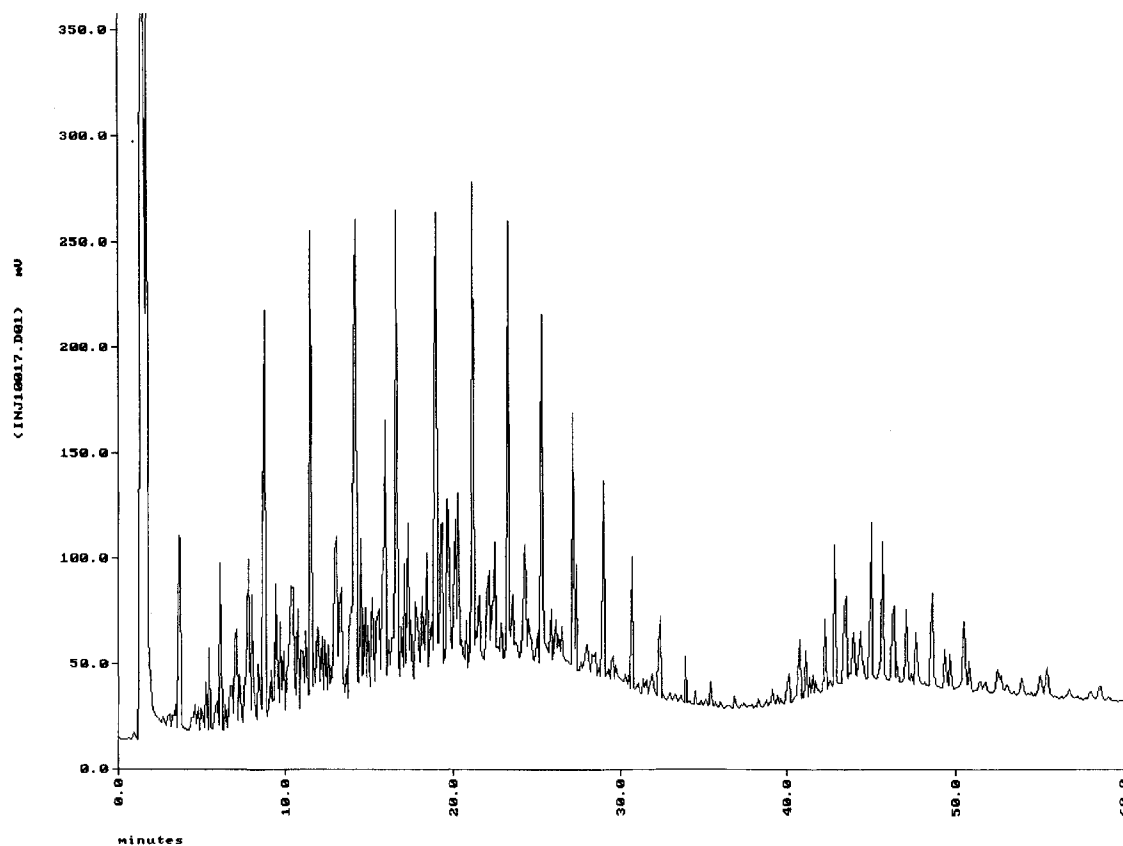

Figure 5: GC-FID chromatogram of the hexane soluble material in loop 1 feed (before the 300 kD MWCO membrane; 50 mL of feed solution extracted using hexane evaporated then diluted with 2 mL of hexane, 4 microlitre injection volume).

3.4.2 Oil and grease concentration in loop 1 permeate

One Litre of permeate sample of the loop 1 membrane (after the 300 kD MWCO membrane) was collected and GC sample was prepared. Chromatogram obtained from GC-FID is shown in Figure 6. The oil and grease concentration in loop 1 permeate (after the 300kD MWCO membrane) was found to be 7.7 ppm. It can be seen by comparing both chromatographs that the 300 kD membrane could retain much of the lubricating oils found in bilge water and some compounds found in the heavier

diesel fraction. However this membrane cut-off could not retain the lighter diesel fraction found in bilge water.

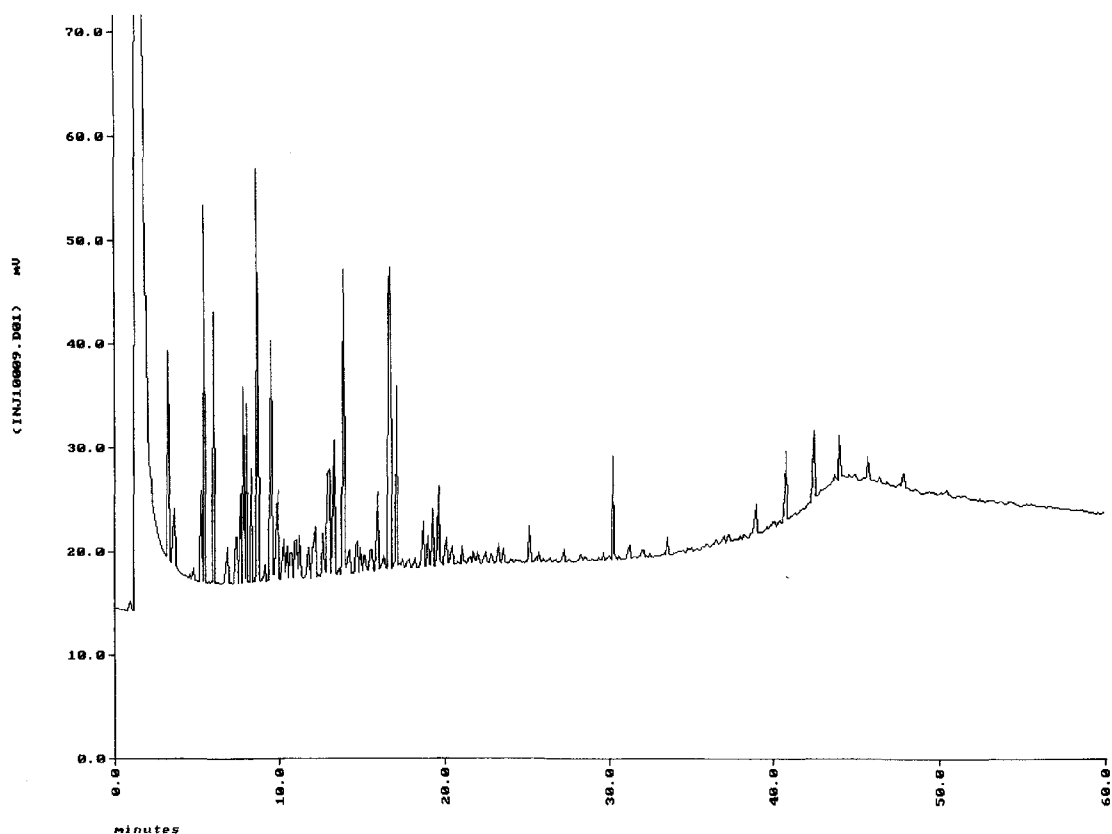

Figure 6: GC-FID chromatogram of the hexane soluble material in loop 1 permeate (after the 300 kD MWCO membrane).

3.4.3 Oil and grease concentration in loop 2 permeate

One Litre of permeate sample of the loop 2 membrane (after the 2 kD MWCO membrane) was collected and GC sample was prepared. Chromatogram obtained from GC-FID is shown in Figure 7. The oil and grease concentration in loop 2 permeate (after the 2 kD MWCO membrane) was found to be 0.0 ppm. Comparing figures 6 and 7, we found that the 2 kD membrane was excellent at removing the remainder of the lubricating oils and all of the diesel found in bilge water.

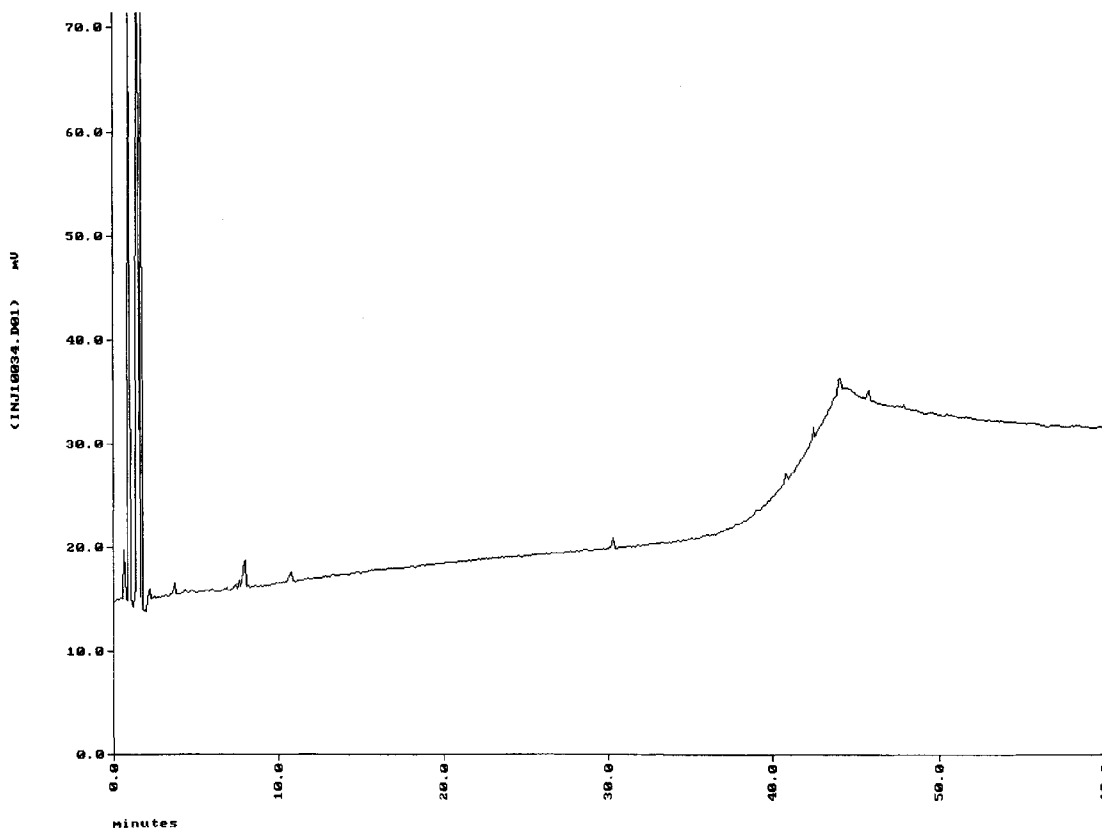

Figure 7: GC-FID chromatogram of the hexane soluble material in loop 2 permeate (after the 2 kD MWCO membrane).

3.5 Separation of oil and grease

The result of oil and grease concentration for permeates from different MWCO membranes can be found in Table 2. Permeate from the first loop was fed directly to the second loop. The results obtained from the 300 kD membrane represent the composition of the feed to the second loop. All other permeates are obtained from loop 2. The results are for an injection of 4 microlitres obtained by extracting 1 litre of solution with 50 mL of hexane, evaporating to dryness at 72 °C and redissolving by adding 2 mL of hexane.

It was found that after treatment in the first loop using the TAMI 300 kD membrane, the O & G concentration in synthetic bilge water decreased from 1649.7 ppm to 7.7 ppm with a rejection rate at 99.6%. The permeate from the first loop was used as feed for the second loop. The average O & G concentration in the second loop was determined

to be 7.1 ppm. The rejection rates for the higher molecular weight membranes (20 kD) was 32.4% while much higher rejection rates above 90% were found for the lower molecular weight membranes (1–5 kD). At a point between 5 and 20 kD organic removal is substantially improved. The best rejection rate (100%) was obtained by the 2 kD membrane. Hexane soluble material in the permeate of the 2 kD membrane was non-detectable.

Table 2: Membrane performance for bilge water purification in a cascade system.

	Membrane (kD MWCO)	Feed concentration (ppm)	Permeate concentration (ppm)	Rejection (%)
Loop 1	TAMI (300)	1649.7	7.7	99.6
Loop 2	CQ (20)	7.1	4.8	32.4
	PT (5)	7.1	0.4	94.4
	GM (4)	7.1	0.7	90.1
	GK (2)	7.1	0.0	100
	GH (1)	7.1	0.1	98.6

4. Conclusions

The following conclusions can be drawn based on the research conducted in this study:

- 1) Solid Phase Extraction (SPE) using an ENVI-18 sorbent was found unsuitable to determine the oil and grease content in dilute solutions of diesel and lubricating oils.
- 2) n-Hexane liquid-liquid extraction technique is an excellent technique to preserve a molecular weight distribution of diesel and lubricating oils separated by Ultrafiltration.
- 3) The hybrid system comprising a 300 kD small pore MF membrane and a 2 kD UF membrane was an excellent combination to remove the hexane extractable organics from bilge water to levels below the detection limit.
- 4) Detergent (sodium salt of dodecylbenzenesulfonic acid) concentrations up to 5 g/L was found to have no effect on the extraction of a 50 ppm diesel and lubricating oil mixture in seawater using hexane as extraction solvent.

5) Membranes having lower MWCOs (1–5 kD) were found to have rejections for hexane extractable material ranging from 90 to 100%. The oil and grease concentration in the permeates from these membranes were all found to be less than 0.7 ppm ranging from 0.0 to 0.7 ppm.

Acknowledgements

The authors gratefully acknowledge the financial support of Defence R&D Canada-Atlantic (DRDC-Atlantic) and donation of equipment from Environment Canada.

References

- [1] International Maritime Organization (IMO), MEPC.5/Circ.6, Pollution prevention equipment required by MARPOL 73/78, London, U.K., July 2002.
- [2] H. Peng, A. Y. Tremblay, D. Veinot, The use of backflushed coalescing microfiltration as a pretreatment for the ultrafiltration of bilge water, *Desalination* 181 (2005) 109-120.
- [3] K. Karakulski, W.A.Morawski, J. Grzechulska, Purification of bilge water by hybrid ultrafiltration and photocatalytic processes, *Separ. Purif. Technol.* 14 (1998) 163-173.
- [4] M. Gryta, K.Karakulski, W.A.Morawski, Purification of oily wastewater by hybrid UF/MD, *Wat. Res.* 35 (15) (2001) 3665-3669.
- [5] U.S.EPA Method 1664 Revision A: n-Hexane Extractable Material (HEM; Oil and Grease) and Silica Gel Treated n-Hexane Extractable Material (SGT-HEM; Nonpolar Material) by Extraction and Gravimetry, EPA-821-R-93-009, EPA Office of Water. 1999.

- [6] American Public Health Association, American Water Works Association, and Water Environment Federation, Standard methods for the Examination of Water and Wastewater, 19th ed., Washington, DC, 1995.
- [7] ASTM D3921-96 (2003) E1. Standard test method for oil and grease and petroleum hydrocarbons in water, Annual Book of ASTM Standards, Philadelphia, 11.02: 360-366, 2004.
- [8] M. Nottegar, A.Y. Tremblay, Bilge Water Membrane Treatment Phenomena Study, contract W7707-7-5321, report for the Department of National Defence (DND), Department of Chemical Engineering, University of Ottawa, Canada, 2000.
- [9] J.J. Langenfeld, S.B.Hawthorne, D.J.Miller, Quantitative analysis of fuel-related hydrocarbons in surface water and waste water samples by solid-phase microextraction, *Anal. Chem.* 68 (1996) 144-155.
- [10] A. Saraullo, P.A.Martos, J. Pawliszyn, Water analysis by solid-phase microextraction based on physical-chemical properties of the coating, *Anal. Chem.* 68 (1997) 1992-1998.
- [11] U. Daiminger, W.Nitsch, P.Plucinski, S.Hoffmann, Novel techniques for oil/water separation, *J. Membr. Sci.* 99 (1995) 197-203.
- [12] ISO/DIS 9377-4. Water quality – Determination of hydrocarbon oil index – Part 4: Method using solvent extraction and gas chromatography, International Organization for Standardization, 1999.
- [13] Z. Wang, M. Fingas, L. Ken, Fractionation of ASMB oil, and identification and quantitation of aliphatic and aromatic and biomarker compounds by GC/FID and GC/MSD (Part I), *J. Chromatogr. Sci.* 32 (1994) 361-366.

- [14] Z. Wang, M. Fingas, L. Ken, Fractionation of ASMB oil, and identification and quantitation of aliphatic and aromatic and biomarker compounds by GC/FID and GC/MSD (Part II), *J. Chromatogr. Sci.* 32 (1994) 367-382.
- [15] Z. Wang, M. Fingas, S. Gary, Study of 22-year-old arrow oil samples using biomarker compounds by GC/MS, *Environ. Sci. Technol.* 28 (1994) 1733-1746.
- [16] Z. Wang, M. Fingas, S. Gary, Chemical characterization of crude oil residues from an Arctic beach by GC/MS and GC/FID, *Environ. Sci. Technol.* 29 (1995) 2622-2631.
- [17] Z. Wang, Analytical Methods for the Determination of Individual (n-Alkanes and Isoprenoids) and Total Petroleum Hydrocarbons (TPH), Polycyclic Aromatic Hydrocarbons (PAHs) and Biomarker Triterpanes and Steranes in Oil and Oil-spill-related Environmental Samples (Water, Particulates and Soils/Sediments), Environmental Technology Centre, Environment Canada, Ottawa, Canada, 2002.
- [18] ASTM D1141-90, Standard Specification for Substitute Ocean Water, *Dod Index of Specifications and Standards*, Canada, 1992.
- [19] H. Peng, A. Y. Tremblay, The selective removal of oil from wastewaters while minimizing concentrate production using a membrane cascade, Accepted for publication in *Desalination*, October 2007.

CHAPTER V

Determination of oil and grease in treated synthetic bilge water produced from a membrane cascade system.

H. Peng, A.Y. Tremblay*

*University of Ottawa, Department of Chemical Engineering
Ottawa, ON, Canada*

*Corresponding author

André Y. Tremblay

Tel.: +1-613-562-5800 ext. 6108; Fax: +1-613-562-5172

E-mail address: tremblay@uottawa.ca

Article will be submitted for publication.

CHAPTER V (Paper 4)

Determination of oil and grease in treated synthetic bilge water produced from a membrane cascade system.

H. Peng, A.Y. Tremblay*

*University of Ottawa, Department of Chemical Engineering
Ottawa, ON, Canada*

*Corresponding author. Tel.: +1-613-562-5800 ext. 6108; Fax: +1-613-562-5172.
E-mail address: tremblay@uottawa.ca

Abstract

This work studied the determination of oil and grease content present in treated synthetic bilge water produced from a pilot-scale membrane cascade system using multilumen tubular ceramic membranes as a first treatment step followed by flat sheet polymeric UF membranes. Permeates of various MWCO membranes were collected and analyzed using an extraction procedure followed by gas chromatography. Experimental results showed that the membrane cascade system can produce water containing hexane extractable material < 1 ppm or non-detectable levels. For a feed concentration of 7.7 ppm, higher MWCOs (20–100 kD) membranes were found to have low rejections of hexane extractable material ranging from 47.9% to 19.7%. Membranes having lower MWCOs (1–5 kD) were found to have rejections rates of organics above 90%. Removal of organic is substantially improved at a point between 5 and 20 kD. More than 94 % of the hexane extractable organics in membrane permeates containing 7 ppm oil and grease exist as micelles having a size of 3.7 to 7.4 nm.

Keywords: Membrane; MWCO; GC-FID chromatogram; Oil and grease; Oily wastewater

1. Introduction

In recent years, considerable attention has been focused on the discharge of oily brines found in bilges of ocean going vessels. These are very challenging to treat due to the diverse and changing composition of these wastewaters onboard ships. Oily water separators (OWS) are usually used to treat bilge waters prior to discharge. Developing an OWS system to meet very low ppm levels of organics for discharge is very challenging. The presence of a high level of divalent salts in oily wastewaters containing seawater (such as bilge water) greatly complicates the removal of oil and grease down to ppm levels by membrane technologies. The conventional approach to solve this problem would be to use a reverse osmosis (RO) membrane to remove all dissolved and suspended material. However, the high osmotic pressure of seawater eliminates this as a feasible approach.

Membrane ultrafiltration (UF) has been identified as a key technology in the treatment of oily wastewaters [1]. Cheryan and Rajagopalan [2] reviewed the treatment of oily wastes using membrane processes and indicated that membranes with pore sizes equivalent to 50,000 – 200,000 MWCO should result in permeates with 10 – 100 ppm of oil. Zaidi et al. [3] performed a comprehensive review of this area and reported on the applications of microfiltration and ultrafiltration membranes for the removal of oil and suspended solids from oilfield brines and concluded that MF/UF technology was able to reduce oil content in oilfield brine to meet the required 20 mg/L discharge levels.

Applications of membrane hybrid system, such as conventional treatment followed by membrane filtration, or dual membrane systems, offers the potential to reach very low discharge levels in oily water treatment. Seo et al. [4] studied residual organic removal in oil wastewater using a hybrid membrane separation activated sludge process and reported more than 95% removal efficiency. Karakulski et al. [5] conducted a study on the purification of bilge water by a combination of ultrafiltration and photocatalytic processes. They employed tubular membranes with MWCO of 70 kD for polyvinyl chloride (PVC) and polyacrylonitrile (PAN) and 100 kD for

polyvinylidene fluoride (PVDF) in a laboratory-scale ultrafiltration system. They found that the oil content in the UF permeate was less than 15 ppm. Gryta et al. [6] investigated the treatment of oily wastewater using a combination of ultrafiltration (UF) and membrane distillation (MD). In this approach, MD was used as a final purification step. A tubular UF module with PVDF membranes and capillary MD module with polypropylene membranes were tested using a typical bilge water without pre-treatment. They reported that the permeate obtained from the UF process generally contained less than 5 ppm of oil. In a study to investigate the possibility of bilge water treatment in an integrated ultrafiltration/reverse osmosis system, Tomaszewska et al. [7] reported that the two stage system have demonstrated a high effectiveness of purification. The permeate from the first stage (tubular FP 100 membrane) was found to have the oil content below 10 ppm. Peng et al. [8] investigated the treatment of synthetic bilge water employing a cascaded membrane system consisting of a backflushed microfiltration membrane used as a pretreatment and an ultrafiltration membrane. Experimental results showed that after treatment with UF membranes, the oil and grease content of the permeate was found to be below the allowable discharge limit for coastal waters, which is 15 ppm of oil.

In a previous study conducted by our lab, Peng and Tremblay [9] developed a pilot scale membrane cascade system for the removal of oil and grease from bilge water to a level where it could be discharged to sensitive environments using membrane technologies. Large channel MF and UF ceramic membranes (300 kD MWCO and 70 nm pore size) were used in the first loop while a variety of flat sheet polymeric UF (1 to 100 kD MWCO) and NF membranes were studied in the second stage (loop 2). Experimental results showed that this cascade system can produce water containing below detectable levels of hexane extractable material. Another study performed by our lab [10] investigated the analytical methods for the determination of oil and grease content present in synthetic bilge water. Research results showed that n-Hexane liquid-liquid extraction technique could obtain a representative molecular weight distribution of diesel and lubricating oils in treated bilge water. Membranes having lower MWCOs (1–5 kD) were found to have rejections rates of organics above 90%.

The objective of this study is to continue our previous work on membrane permeate analysis to investigate oil and grease concentration in the permeates from various commercially available membranes and the effect of membrane MWCOs on separation of oil and grease in synthetic bilge water. Another objective is to determine if at sub-ppm oil levels, oil and grease is present as dissolved organic matter or as nanosized particulates that could effectively be removed by small pore UF membranes.

2. Experimental

2.1 Bilge water preparation

In this study, synthetic oily brine was made up from components including sea water, distillate fuel, lubricating oil, surfactant, etc. This mixture represented about 5.3 g/L (5,300 ppm) oil and grease in oily brine. Details of the mixture can be found in another paper prepared by our lab earlier [9].

2.2 Sample collection

Experiments were conducted using a pilot scale membrane cascade system using tubular MF and UF membranes in a first stage, where high levels of particulate matter are present, and more compact (higher membrane area per unit volume) spiral wound modules in the second stage. Large channel MF and UF ceramic membranes (300 kD MWCO and 70 nm pore size) were used in the first loop while a variety of flat sheet polymeric UF (1 to 100 kD MWCO) and NF membranes were studied in the second stage (loop 2). Permeates obtained from the first and second stages were collected and analyzed using an extraction procedure followed by gas chromatography. Liquid samples of loop 1 feed, loop 1 permeate, loop 2 retentate, cell 1 permeate and cell 2 permeate were collected for O & G analysis. Details of the experimental set up, membranes used, and experimental procedure can be found in another paper prepared by our lab earlier [9].

2.3 n-Hexane liquid-liquid extraction

Details of the n-Hexane liquid-liquid extraction technique can be found in another paper prepared by our lab earlier [10].

2.4 Gas chromatography (GC)

Details of the Gas Chromatography (GC) injection procedure can be found in another paper prepared by our lab earlier [10].

3. Results and discussion

Experiments were performed using a 300 kD ceramic membrane in the first loop and a variety of membranes in loop 2 ranged from 1 kD MWCO to 100 kD MWCO UF membranes. Permeates from the first and the second loop were collected and contacted with hexane and the hexane soluble material concentrated in a rotary evaporator. Care was taken to provide some degree of reflux in the evaporator in order to prevent the lower molecular weight fractions of diesel from escaping the evaporator. The samples were evaporated to dryness and 2 mL of hexane were added to the sample prior to analysis by GC-FID.

In a previous study [10], n-Hexane liquid-liquid extraction technique was found to be able to obtain a representative molecular weight distribution of diesel and lubricating oils in treated bilge water. Detergent (sodium salt of dodecylbenzenesulfonic acid) concentrations up to 5 g/L was found to have no effect on the extraction of a 50 ppm diesel and lubricating oil mixture in seawater using hexane as extraction solvent.

3.1 Oil and grease concentration in loop 1 feed and permeate

Fifty (50) mL of feed solution in the inlet of the loop 1 membrane (before the 300 kD MWCO membrane) and one Litre of permeate sample of the loop 1 membrane (after the 300 kD MWCO membrane) were collected and GC samples were prepared.

Chromatograms obtained from GC-FID for feed and permeate are compared on same scale and shown in Figure 1 below. The oil and grease concentration in loop 1 feed was found to be 1,649.7 ppm. The oil and grease concentration in loop 1 permeate (after the 300 kD MWCO membrane) was found to be 7.7 ppm.

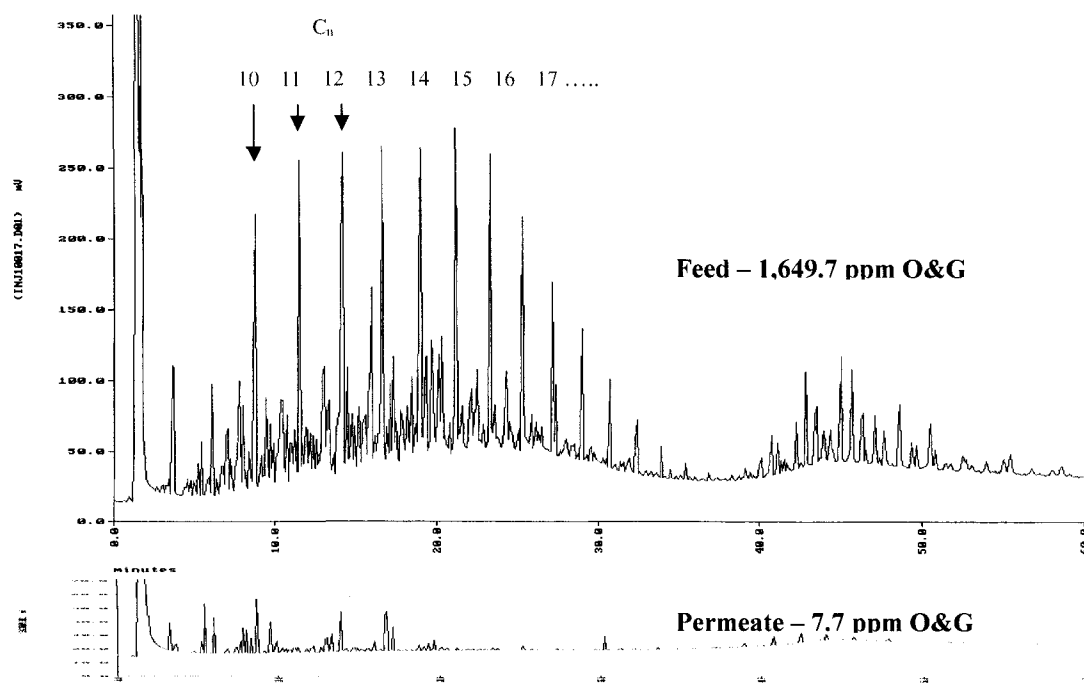

Figure 1: GC-FID chromatograms of the hexane soluble material in loop 1 feed and permeate (before and after the 300 kD MWCO membrane).

3.2 Oil and grease concentration in UF permeates

Chromatograms obtained from GC-FID are shown in Figures 2 and 3. The chromatogram for the 300 kD membrane is that of the permeate from loop 1. Permeate from the first loop was fed directly to the second loop. The results obtained from the 300 kD membrane represent the composition of the feed to the second loop. All other permeates are obtained from loop 2. The results are for an injection of 4 microlitres obtained by extracting 1 litre of solution with 50 mL of hexane, evaporating

to dryness at 72 °C and redissolving by adding 2 mL of hexane. All the scales in the composite Figures are identical, they are plots of mV vs. time.

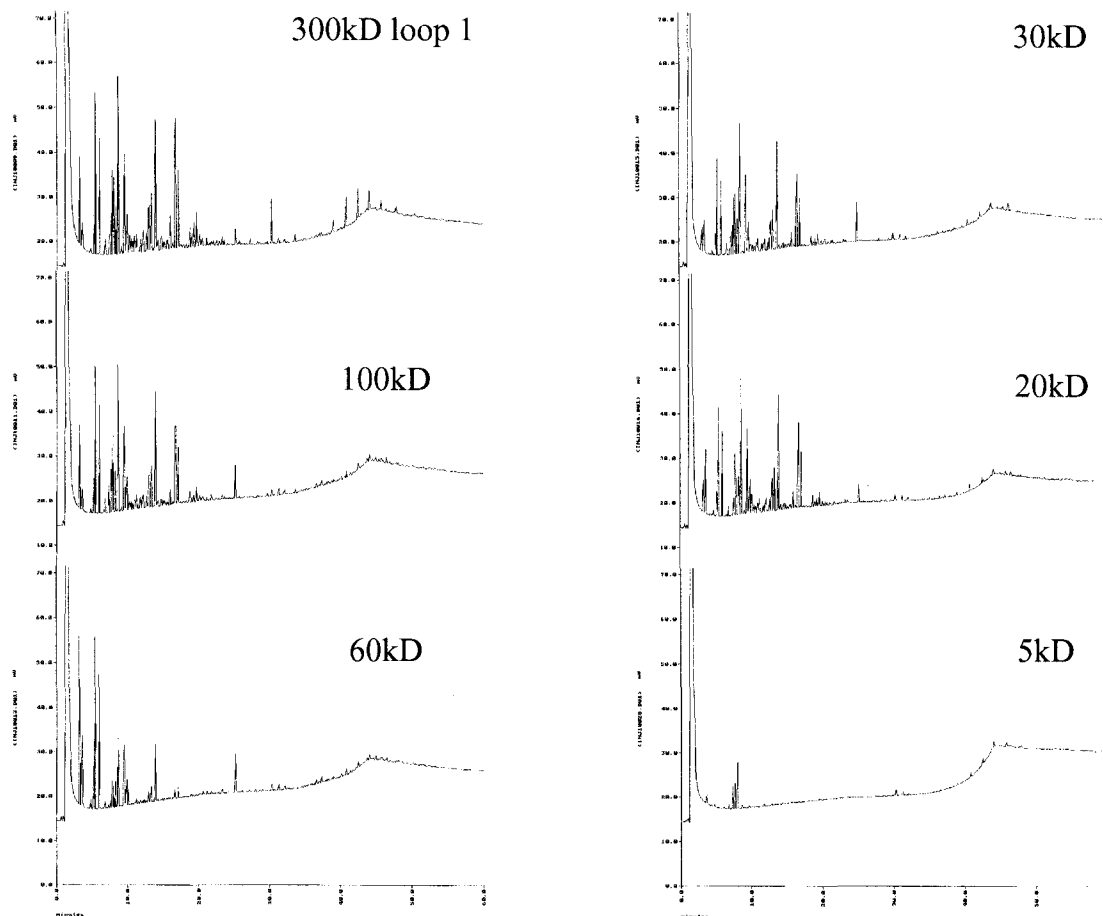

Figure 2: GC-FID chromatograms of the hexane soluble material in loop 1 (300 kD MWCO) and loop 2 permeates for membranes in the 5 kD to 100 kD MWCO range.

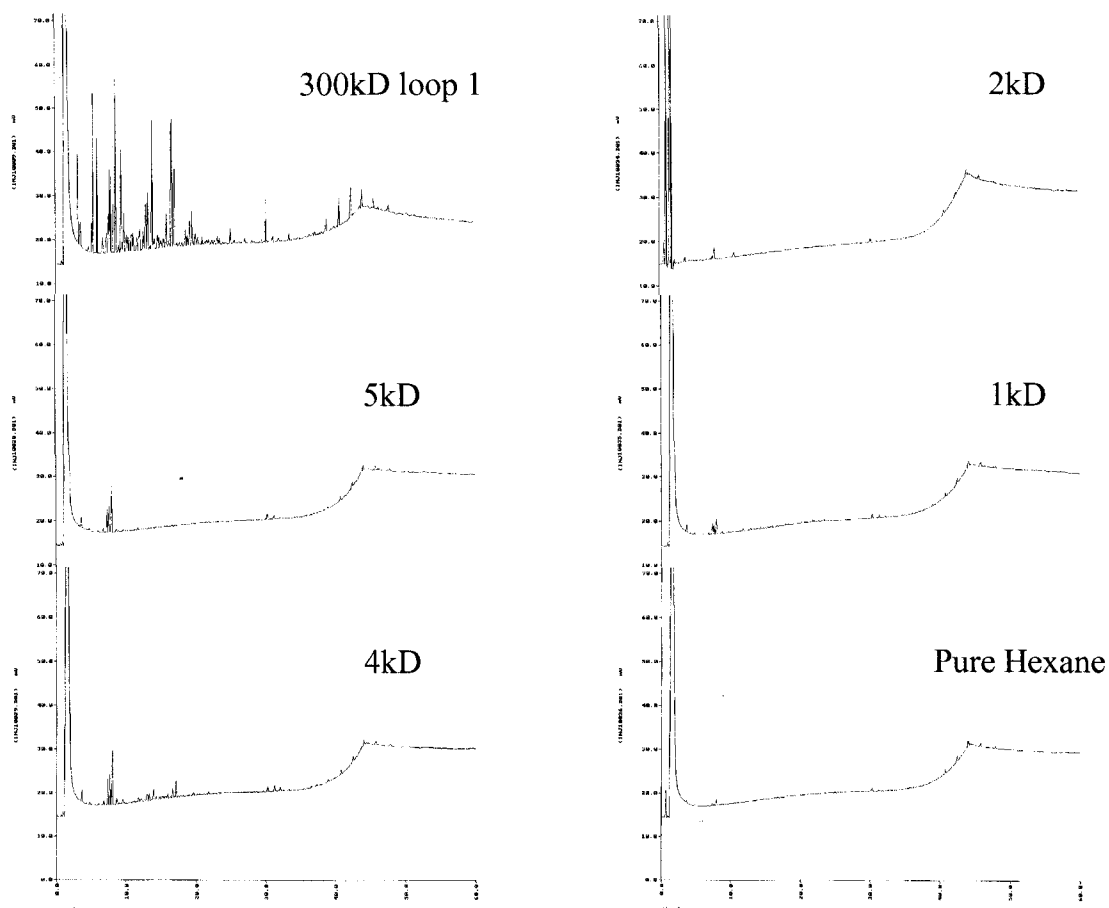

Figure 3: GC-FID chromatograms of the hexane soluble material in loop 1 (300 kD MWCO) and loop 2 permeates for membranes in the 1 kD to 5 kD MWCO range.

The following observations can be made from these results:

- 1) Looking at Figure 1, we can notice that the chromatograph of the 300 kD permeate that aliphatic below (and including) C13 are not retained by the 300 kD membrane and that some lubricating oils are permeating through the membrane.
- 2) Looking at Figure 2, when comparing the results for the 300 kD membrane and the cascaded 100 kD membrane, most of the higher molecular weight lubricating oils were removed by the 100 kD and lower molecular weight cut-off membranes.
- 3) C13 and lower aliphatics are not removed by the membranes above 20 kD.
- 4) At a point between 5 and 20 kD organic removal is substantially improved. The separation was found most effective in the 1 to 5 kD range.
- 5) The best oil and grease removal was obtained by the 2 kD membrane.

6) The molecular weight of diesel components such as C10 to C16, aliphatics and aromatics, are in the range of 128 to 226 g/gmol. These molecular weights are much lower than the cut-offs of the membranes. This indicates that some association of the hydrocarbons is occurring at these very low concentrations.

3.3 Separation of oil and grease

The results of oil and grease concentration for permeates from different MWCO membranes are presented in Table 1. It can be found that after treatment in the first loop using the TAMI 300 kD membrane, the O & G concentration in synthetic bilge water decreased from 1649.7 ppm to 7.7 ppm with a rejection rate at 99.6%. The permeate from the first loop was used as feed for the second loop. The average O & G concentration in the second loop was determined to be 7.1 ppm. The rejection rates for the higher molecular weight membranes (20 – 100 kD) ranged from 19.7% to 47.9% while much higher rejection rates above 90% were found for the lower molecular weight membranes (1–5 kD). The change in oil and grease concentration from 5 kD to 20 kD suggests that organics are present as micelles whose size range between 3.7 and 7.4 nm. The best rejection rate (100%) was obtained by the 2 kD membrane. Hexane soluble material in the permeate of the 2 kD membrane was non-detectable.

Table 1: Membrane performance for bilge water purification in a cascade system.

	Membrane (kD MWCO)	Feed concentration (ppm)	Permeate concentration (ppm)	Rejection (%)
Loop 1	Tami (300)	1649.7	7.7	99.6
Loop 2	MW (100)	7.1	5.7	19.7
	EW (60)	7.1	3.7	47.9
	JW (30)	7.1	4.5	36.6
	CQ (20)	7.1	4.8	32.4
	PT (5)	7.1	0.4	94.4
	GM (4)	7.1	0.7	90.1
	GK (2)	7.1	0.0	100
	GH (1)	7.1	0.1	98.6

3.4 Aliphatic vs. aromatic content of the permeates

The resulting species found in the permeate from the 1-5 kD membranes (between 6 and 10 minutes retention time) are most likely aromatic. Diesel fuels can contain between 13 to 20 % polycyclic aromatic hydrocarbons (PAHs) [11]. Substituted di-aromatics are quite common in diesel blends and would give GC retentions that do not exhibit the periodicity of alkanes. These aromatics are also more soluble in water than alkanes of comparable molecular weight. Table 2 lists the solubility of PAHs most commonly found in Diesel Fuel #2, while Table 3 lists the solubilities of lower molecular weight alkanes found in diesel. It can be easily seen that aromatic hydrocarbons, of comparable molecular weight, have water solubilities that are 3 to 4 orders of magnitude greater than straight chain alkanes found in diesel.

Table 2: Example of typical PAHs found in composite Diesel Fuel #2
(Data from EPI Win data base US EPA)

PAH	Formula	Structure	Formula weight	CAS Number	Normal Boiling Point (°C)	Solubility in Water at 25°C (mg/L)
Naphthalene	C ₁₀ H ₈		128.17	91-20-3	218	31
1-methylnaphthalene	C ₁₁ H ₁₀		142.20	90-12-0	240	25.8
2-methylnaphthalene	C ₁₁ H ₁₀		142.20	91-57-6	241	24.6
Acenaphthylene	C ₁₂ H ₈		152.19	208-96-8	280	16.1
Acenaphthene	C ₁₂ H ₁₀		154.21	83-32-9	279	3.9
Fluoranthene	C ₁₃ H ₁₀		166.22	86-73-7	295	1.89
Phenanthrene	C ₁₄ H ₁₀		178.23	85-01-8	340	1.15

Table 3: Properties of lower molecular weight C10 to C16 alkanes found in diesel (Data from EPI Win data base US EPA).

Hydrocarbon	Formula	Formula weight	CAS Number	Normal Boiling Point °C	Solubility in Water at 25 °C (mg/L)
n-decane	C ₁₀ H ₂₂	142.28	124-18-5	174	0.052
n-undecane	C ₁₁ H ₂₄	156.31	1120-21-4	196	0.0044
n-dodecane	C ₁₂ H ₂₆	170.33	112-40-3	216.3	0.0037
n-tridecane	C ₁₃ H ₂₈	184.36	629-50-5	235.4	0.0047
n-tetradecane	C ₁₄ H ₃₀	198.39	629-59-4	253.5	0.0022
n-pentadecane	C ₁₅ H ₃₂	212.41	629-62-9	270.6	0.00008
n-hexadecane	C ₁₆ H ₃₄	226.44	544-76-3	286.8	0.0009

This leads us to conclude that the permeate from the 300 kD membrane fed to the second loop was composed of both; nanosized droplets containing alkanes and PAHs, and PAHs in solution. The solubility of PAHs is above the minimum concentration of 3.7 ppm observed for all membranes above 20 kD. It is only below 5 kD that the permeate concentration drops below 1 ppm. This suggests that the alkanes are acting as carriers for the PAHs and that the size of these nanoparticles is between 3.7 to 7.4 nm (5 to 20 kD MWCO). Figure 4 shows the distribution of particle sizes in treated synthetic bilge water (DLS). It can be found that these particles are located in the lower end of ultrafiltration.

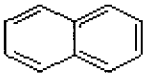
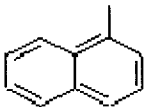
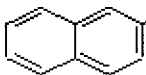
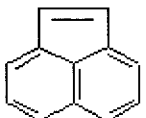
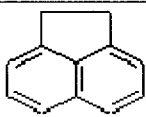
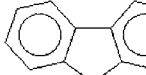
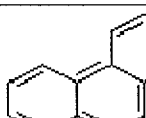
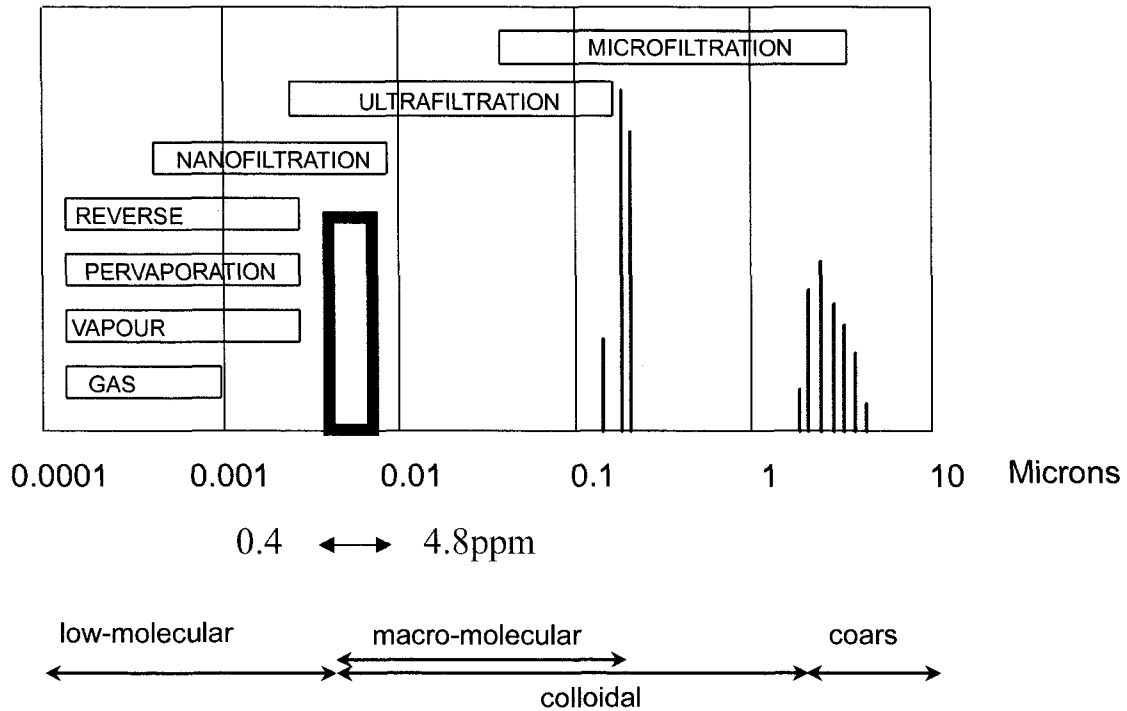

Figure 4: Particle size distribution in treated synthetic bilge water (DLS).

4. Conclusions

The following conclusions can be drawn based on the research conducted in this study:

- 1) Experimental results showed that a pilot-scale membrane cascade system using multilumen tubular ceramic membranes as a first treatment step followed by flat sheet polymeric UF membranes can produce water containing hexane extractable material < 1 ppm or non-detectable levels.
- 2) For a feed concentration of 7.7 ppm, higher MWCOs (20–100 kD) membranes were found to have low rejections of hexane extractable material ranging from 47.9% to 19.7%. Membranes having lower MWCOs (1–5 kD) were found to have rejection rates of organics above 90%.
- 3) Removal of organic is substantially improved at a point between 5 and 20 kD.
- 4) More than 94 % of the hexane extractable organics in membrane permeates containing 7 ppm oil and grease exist as micelles having a size of 3.7 to 7.4 nm.

Acknowledgements

The authors gratefully acknowledge the financial support of Defence R&D Canada-Atlantic (DRDC-Atlantic) and donation of equipment from Environment Canada.

References

- [1] Zeman L.J. and A.L.Zydney, "Microfiltration and Ultrafiltration, Principles and Applications", Marcel Dekker, 1996.
- [2] Cheryan M. and N. Rajagopalan, "Membrane Processing of Oily Streams. Wastewater Treatment and Waste Reduction", *J. Membr. Sci.*, 151, 13-28, 1998.
- [3] Zaidi A., K. Simms and S. Kok, "The use of micro/ultrafiltration for the removal of oil and suspended solids from oilfield brines", *Wat. Sci. Tech.*, Vol.25, No. 10 pp.163-176, 1992.
- [4] Seo G.T., T.S. Lee, B.H. Moon, K.S. Choi and H.D. Lee, "Membrane separation activated sludge for residual organic removal in oil wastewater", *Wat.Sci.Tech.*, Vol. 36, No. 12, pp.275-282, 1997.
- [5] Karakuiski K., W.A.Morawski and J. Grzechulska, "Purification of bilge water by hybrid ultrafiltration and photocatalytic processes", *Separ. Purif. Technol.*, 14 (1998) 163-173.
- [6] Gryta M., K.Karakulski and A.W.Morawski, "Purification of oily wastewater by hybrid UF/MD", *Wat. Res.*, Vol. 35, No. 15, pp.3665-3669, 2001.
- [7] Tomaszewska M., A. Orecki and K. Karakuiski, "Treatment of bilge water using a combination of ultrafiltration and reverse osmosis", *Desalination*, 185 (2005) 203-212.

[8] Peng H., A. Y. Tremblay and D. Veinot, "The use of backflushed coalescing microfiltration as a pretreatment for the ultrafiltration of bilge water", *Desalination*, 181 (2005) 109.

[9] Peng H. and A. Y. Tremblay, "The selective removal of oil from wastewaters while minimizing concentrate production using a membrane cascade", accepted for publication in *Desalination*, October 2007.

[10] Peng H. and A. Y. Tremblay, "The analysis of treated bilge water from a combined MF/UF hybrid membrane system", in preparation, December 2007.

[11] Guthrie J., Fowler, P., Sabourin R., "Gasoline and Diesel Fuel Survey", Environment Canada report, September 2003.

CHAPTER VI

Waste minimization in treating oily wastewaters by microfiltration.

H. Peng, A.Y. Tremblay*

*University of Ottawa, Department of Chemical Engineering
Ottawa, ON, Canada*

*Corresponding author

André Y. Tremblay

Tel.: +1-613-562-5800 ext. 6108; Fax: +1-613-562-5172

E-mail address: tremblay@uottawa.ca

Article submitted for publication.

CHAPTER VI (Paper 5)

Waste minimization in treating oily wastewaters by microfiltration.

H. Peng, A.Y. Tremblay*

*University of Ottawa, Department of Chemical Engineering
Ottawa, ON, Canada*

*Corresponding author. Tel:

E-mail address:

Abstract

Traditional membrane cleaning methods generate waste cleaning waters; whose disposal costs are an increasing concern. The use of backflushed coalescing microfiltration for the pre-treatment of oily wastewaters prior to ultrafiltration is an interesting technique offering potential as a physical pretreatment method. The concept of this technique is to pre-treat oily wastewaters with a large pore microfiltration membrane operated with backflushing where the oils are partly coalesced in the pores of the membrane. The permeate from this membrane can then be treated by ultrafiltration. The coalescing membrane must eventually be regenerated in order to maintain a desirable permeate flux. The present work investigates environmentally friendly physical membrane cleaning methods, such as backflushing with hot water or steam followed by pressurized air. The treatment of oily wastewater containing half seawater using a MF/UF hybrid system was studied in this work. The beneficial effects for steam cleaning were quite evident. The results were also modeled using four traditional fouling models and a combined filtration model. They indicate that fouling of microfiltration membranes is due to the presence of oil and grease and seawater colloids in membrane pores. Optimal cycle times between physical cleanings were found to be in the range of 1.6 to 2.2 hours.

Keywords: Pretreatment; Fouling; Cleaning; Backflushing; Oily wastewater

1. Introduction

New environmentally friendly membrane cleaning methods are needed to minimize liquid wastes generated in the operation of membrane systems. The treatment of oily wastewaters containing particulates is a problem found in many industries. These streams are difficult to treat by membrane systems due to heavy fouling. Wastewaters accumulating in the lower recesses of a ship are an example of an oily wastewater containing particulates and dissolved ions. These wastewaters contain a complex “cocktail” of mechanical and chemical emulsions, and contaminants. Typical contaminants may include fuels, oils, detergents, greases, solvents, rusts, paints, insulation material and a wide variety of other substances. The varied nature and composition of these oily wastewaters pose a more difficult separation problem than the treatment of conventional oil in water emulsions. Membrane technology in wastewater treatment has moved forward quickly in recent years because of the development of new technologies for the manufacture of membranes. Membrane ultrafiltration (UF) has been identified as a key technology in the treatment of oily wastewaters [1]. Microfiltration (MF) membranes with a pore size of 0.1 μm were found to be effective in the separation of oily wastewaters and the recovery of surfactants [2].

In the treatment of bilge water using membrane systems, suspended solids and oils in bilge water can block the feed channels of spiral and hollow fiber modules and cause frequent pre-filter changes and cleaning. This causes membrane flux reduction and increases the labor associated with the operation of the system. Therefore, the development of a cost-effective membrane cleaning method is desirable in this application.

Various cleaning approaches have been used to regenerate permeate flux. Membrane cleaning methods can be broadly categorized into four types: chemical, physical, physico-chemical and biological.

Chemical methods are the most widely used procedures in membrane cleaning. Many studies can be found in the literature using various cleaning agents such as; alkalies, acids, enzymes, surfactants, sequestering agents, formulated agents and disinfectants [3-8]. However, the drawbacks of chemical cleaning methods include: the generation of new waste solutions; higher costs; and the operational aspects of chemical supply and handling problems, especially in a ship or remote places.

Physical methods depend on mechanical treatment to remove foulants from the surface of the membrane and enhance cleaning effectiveness. These mechanical treatments include: sponge ball cleaning [9], air sparging [10], vibration [3], ultrasonication [11], and backflushing [12-16]. Physical methods are good for removing the cake produced on the surface of the membrane, but they are associated with operational problems and a lack of efficiency. For example, the operation and handling of sponge ball cleaning equipments is not a simple task.

Physico-chemical methods involve the use of chemicals in addition to the above [3, 17]. Biological methods use cleaning mixtures which contain bioactive agents to enhance cleaning effectiveness. Most of the studies in this field report the use of enzymes as cleaning agents [18-20].

Physical cleaning is a preferred method, among the four membrane cleaning methods, as it does not have chemical supply, storage and handling problems. This method is, environmentally friendly while the other three methods include the use of chemical or bioactive agents which will inevitably create wastes.

In a previous study, Peng et al. [21] investigated the treatment of synthetic bilge water employing a cascaded membrane system consisting of a backflushed microfiltration membrane used as a pretreatment and an ultrafiltration membrane. The benefit of using backflushing as a membrane cleaning method is evident in this study. Experimental results showed that backflushing of MF membranes offered flux improvements for single tube carbon membranes. With backflushing, the permeate

production was 5-8 times more than the cases of cross-flow alone. The cascaded MF/UF approach permits a higher UF membrane packaging density as the pretreatment produces a feed that contains less oil droplets and particulate matter.

Experimental results in this previous study outlined the need for MF membranes offering good particulate clearance to be used in backflushing coalescence applications. Results also showed that the pretreatment of this oily wastewater, prior to ultrafiltration, is desirable as used oil and particulates can block the feed channels of UF spiral and hollow modules. This led us to conclude that further investigation of the use of backflushed coalescing microfiltration for the pre-treatment of oily wastewaters prior to ultrafiltration would be an interesting technique offering potential as a physical pretreatment method.

The objective of this study is to investigate membrane cleaning methods and compare the results on cleaning the membrane by backflushing, hot water, steam, air and the use of commercial cleaners in the treatment of synthetic bilge water using a MF/UF hybrid system.

2. Experimental

2.1 Oily wastewater (bilge water) preparation

Synthetic bilge water was prepared from constituents described as below:

- i) 2000-mg/L oils,
- ii) 500-mg/L detergents and surfactants, and
- iii) 50/50 mixture of fresh water + seawater (approximately 99.75%).

This formed the basis for the makeup of the standard bilge water solution used in most tests. The oils were composed of the following:

- i) 50% diesel fuel,
- ii) 40% used diesel engine lubricating oil, and
- iii) 10% hydraulic oil.

The detergents and surfactants were composed of the following:

- i) 90% oil and grease detergent (CLEANBREAK),
- ii) 10% corrosion removal compound (OSTREM Rust Stain Remover).

Synthetic ocean water was prepared according to “Standard Specification for Substitute Ocean Water”, ASTM D1141-90 (1992) [22].

2.2 Membranes

2.2.1 Carbon MF membrane

The KOCH carbon membrane (KOCH Membrane Systems, Ann Arbor, Michigan, USA) was made from sintered carbon. The fine selective layer on the membrane is made from carbon. It is not coated by an inorganic material. The characteristics of this membrane are shown in Table 1.

Table 1: KOCH Carbo-cor Membrane Characteristics.

Membrane configuration	Tubular (single channel)
Inside diameter, mm	6
Outside diameter, mm	8
Length, mm	1200
Membrane area, m ²	0.022
Maximum operating pressure, psig	600
Maximum backpulsing pressure, psig	1500
Maximum operating temperature, °C	165
Pore size tested, μm	0.1, 1.4

2.2.2 Polymeric UF membrane

The KOCH XM50 polymeric hollow fiber membrane (KOCH Membrane Systems, Ann Arbor, Michigan, USA) was made of polyvinyl chloride/polyacrylonitrile (PVC/PAN) co-polymer. The characteristics of KOCH XM50 membrane are summarized in Table 2 below.

Table 2: KOCH XM50 Hollow Fiber Membrane Characteristics.

Membrane Configuration	Hollow fiber
Composition	PVC/PAN (co-polymer)
Nominal MWCO	50,000 Daltons
Length	0.417m
Surface area	0.092416m ² (1ft ²)

2.3 Experimental set-up

Membrane MF/UF pilot tests were performed in the system shown in Figure 1. Two membrane circulation loops are present in this system, the MF loop served as pretreatment to the UF loop. During the experimental runs, MF permeate was sent to the UF loop while MF concentrate was circulated back to feed tank. Four pumps were employed in the system; one acted as a feed pump feeding bilge water to the MF loop, a second pump was used to circulate feed in the MF loop, a third pump circulated fluid in the UF loop and a pneumatic diaphragm pump, acted as a backflushing pump, drawing a suction from the UF permeate tank to backflush the MF membrane module. The contents of the feed tank were continually mixed to prevent the de-phasing of the bilge water.

Permeate from the UF loop was collected in a small 6 L permeate tank. The level in the tank was monitored to determine permeate flowrate. Liquid in the tank was used to backflush the membranes as needed. The permeate tank was linked to a pneumatic valve which served as a backflushing valve. The valve was computer-controlled. This valve was normally closed. During the backflushing operation the valve was opened and the permeate was backflushed through the MF membrane. The total operational cycle time and the backflushing times were set by the operator and controlled by the computer.

The temperature of the system was controlled by a water-cooled coil in the feed tank.

A platinum RTD (Resistance Temperature Detector) probe placed in the MF loop provided an accurate measure of the feed temperature. A computer operated ON/OFF pneumatic valve controlled the flow of water through the coil in the tank. Once the temperature in the system reached its set point, the system was able to maintain the temperature of the feed solution within $\pm 0.1^\circ\text{C}$ of the set point.

The temperature, pressure, flux of permeate and retentate were graphically displayed on the PC screen and recorded. LABVIEW software (National Instruments) was used to control the system and acquire data.

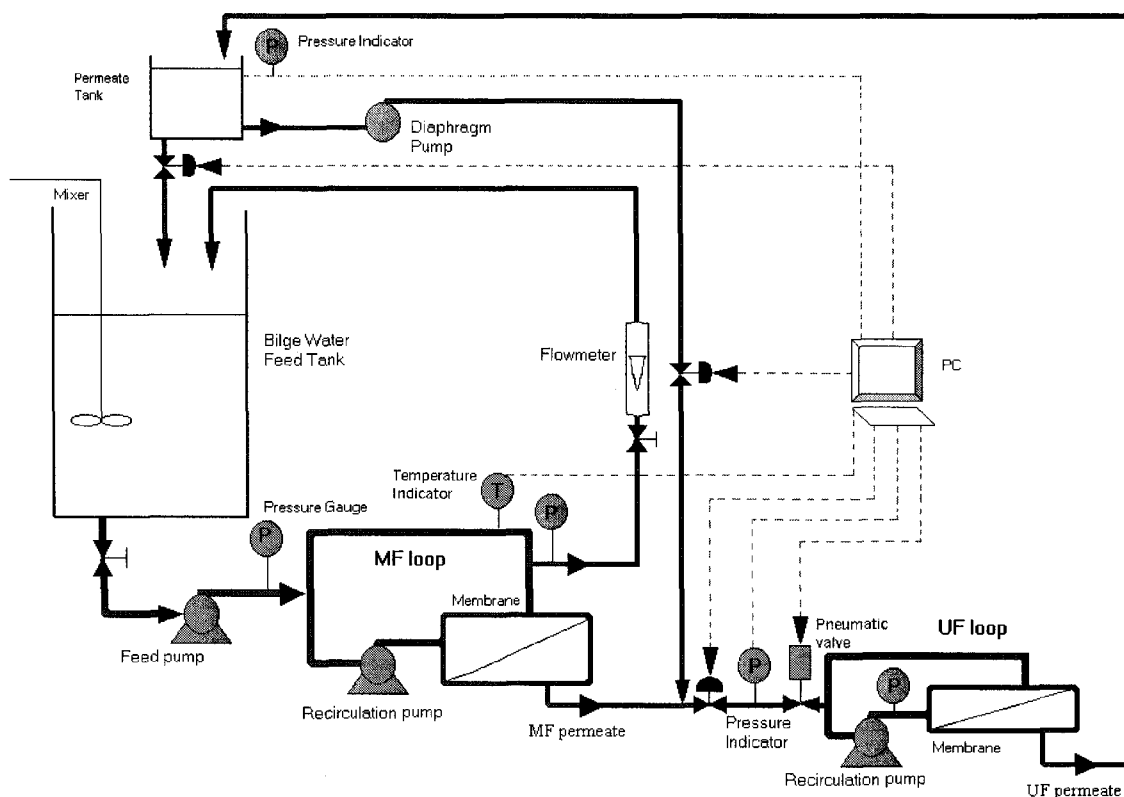

Figure 1: Schematic diagram of the MF/UF hybrid system.

2.4 Experimental procedure and analytical methods

All pilot scale runs were carried out at a tangential velocity of 5 to 6 m/s. A test volume of 100 L synthetic bilge water was prepared at room temperature and mixed in the feed tank for several hours before each run. Normally, a run lasted for 3 to 6 days.

Prior to the chemical cleaning tests, the KOCH carbon membranes were removed from the system and cleaned according to the initial base (1% NaOH) and acid (2% HNO₃) cleaning procedures recommended by KOCH Membrane Systems.

The MF membrane was physically cleaned prior to each run. The UF membrane was not cleaned for the entire series of runs. For some of the runs using the carbon membranes, cleanings were performed using hot water, steam or air. For hot water cleaning, the membrane remained in the loop. Hot water at a given temperature was circulated in the MF loop for 20 min to 1 hour and air was backflushed through the membrane for 10 min. For the steam cleaning runs, pressurized steam (1.1 to 2.4 barg, or 16 to 35 psig) was applied on the permeate side of the membrane for 5 to 10 min, followed by air backflushing (2.07 barg, or 30 psig) for 10 min. The membrane was then backflushed with 100 to 200 mLs of UF permeate at 4.13 barg (60 psig). Chemical cleanings were performed using KLDII cleaner purchased from KOCH Membrane Systems Incorporated (Ann Arbor, Michigan, USA). The membranes were removed from the loop to prevent the contamination of the bilge water with the KLDII cleaning solution. All membranes were cleaned in a separate cleaning loop. The concentration of KLDII was 10 mL per litre of water. Washes were conducted at high cross-flow velocities and low trans-membrane pressure (0.21-0.34 barg, or 3-5 psig). The cleaning of the 50 kD UF membrane could also be conducted using the chemical cleaning procedure described above, which has been introduced in a previous study [21].

The operating temperature was controlled to $35 \pm 0.1^\circ\text{C}$. For different runs, there was a slight difference in temperature due to a change in environmental operating conditions such as room temperature and recovery within the MF loop which varied slightly throughout the runs. The results of permeate flux in this work were corrected to 25°C or 35°C in accordance with ASTM standard D5090-90 entitled: "Standardizing Ultrafiltration Permeate Flow Performance."

3. Results and discussion

3.1 Chemical cleaning

Results from a previous study indicated that fouling of the single tube carbon membranes was due to the presence of the particles found in bilge water [21]. Three different chemical cleaning methods were evaluated for the KOCH carbon 0.1 μm membranes after 6-days of operation treating bilge water without backpulsing. These methods are as follows;

1. Clean with KLDII solution for 30 min with concentration 10 mL/L at 2.07 barg (30 psig), 40 °C then rinse with RO water.
2. Clean with 1% NaOH solution at 2.07 barg (30 psig), 40 °C, for 30 min, rinse with RO water, then backflush with air for 5 min at 2.07 barg (30 psig).
3. Clean with 1% NaOH solution at 2.07 barg (30 psig), 40 °C, for 30 min then rinse with RO water.

Figure 2 shows the regenerated flux for the KOCH carbon 0.1 μm membrane for the three different cleaning methods described above. Cleaning methods 2 (with NaOH and air) and 3 (with NaOH) regenerated the membrane to a greater extent than the first method (with KLDII). Cleaning with 1% NaOH and backflushing with air produced the highest initial and overall flux. The results suggest that the cleaning mechanisms for KLDII and NaOH are very different. KLDII relies on the solubilisation of oil and grease by the formation of micelles while NaOH breaks down hydrocarbons by hydrolysis. Treating these membranes with NaOH and then backflushing with air would produce a cleaning solution that could be neutralized and reprocessed through the membrane system eliminating the need for a cleaning solution holding tank. This cleaner would be inexpensive and environmentally benign. It would however require the handling of strong acids and bases. In many instances, the handling of acids and bases are to be avoided, as spills are difficult to clean and remain a major safety concern.

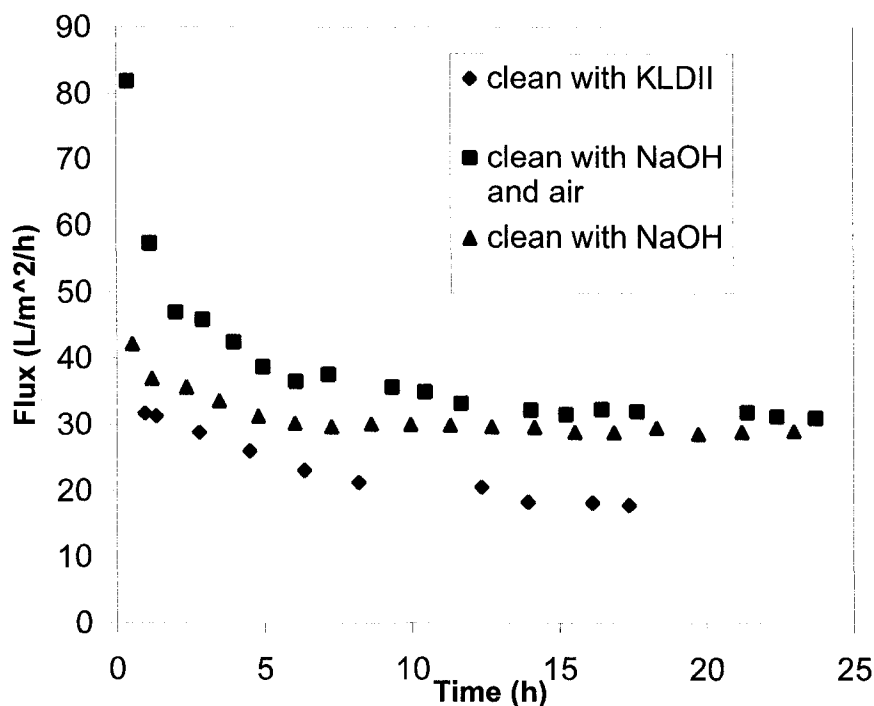

Figure 2: Plot of Flux vs. Time for the KOCH carbon 0.1 μm membrane after cleaning (TMP=1.72 barg (25 psig), 25°C).

3.2 Air, hot water and steam cleaning

In order to further study environmentally friendly cleaning methods for membrane flux regeneration, hot water, air and pressurized steam were used to clean the KOCH Carbo-cor 1.4 μm membrane. In a previous study [21], the Carbo-cor 1.4 μm membrane was identified to have the best performance in a treating bilge water using a MF/UF hybrid system. During the permeate run, small particles and oil emulsions present in synthetic bilge water can penetrate inside the pores of the 1.4 μm membrane. Visual observations indicate that free oil is also present in bilge water. Should these smaller particles enter the pores of the membrane, they can coalesce and block the pores.

Air backflushing is a simple technology that can be used for membrane cleaning. The air pressure applied needs to be higher than the bubble point pressure of the membrane in order to flush oil out of membrane pores. The bubble point method is widely used

for membrane pore size characterization. The bubble point equation is essentially the capillary rise equation [23]:

$$P = \frac{4\gamma \cos\theta}{d} \quad (1)$$

Where P is the bubble point pressure, d is the membrane pore diameter, γ is the surface tension of the liquid filling the pores and θ is the liquid-solid contact angle. Bubble point pressure of a specific membrane can be determined by measuring the contact angle. The worst case (highest pressure requirement) for wetting the pores will be for a contact angle of 0° . For water, with a surface tension of 72 dynes/cm, and a contact angle of 0° , the bubble point pressure reduces to

$$P = \frac{42}{d} \quad (2)$$

Where P is in psig and d is in μm [23]. For a membrane with a 1.4 μm pore size, the minimum air pressure required to empty and fill membrane pores is 2.07 barg (30 psig).

Heating the membrane should further enhance the removal of oil. Heat will reduce the viscosity of the free/emulsified oil blocking the membrane pores. The temperature of the membrane prior to air backflushing will affect the removal of oil. Higher temperatures should produce a membrane having a greater number of open pores.

A series of nine cleaning tests were performed. The MF/UF system treated bilge water for an average of 22 hours after each cleaning. The cleanings of the MF membranes were performed as follows:

1) Hot water and air

- Five hot water cleanings were performed by circulating hot water at 25, 60, 80, 90 and 100 °C on the permeate side of the membrane with feed solution inside the MF loop for 20 min. The membrane was then backflushed using

air and UF permeate from the permeate side as described in section 2.4. Test results after these cleanings are shown in the first 5 curves in Figure 3.

- After the first 5 tests, three hot water cleanings were performed by circulating hot water at 100 °C on the permeate side of the membrane with feed side of the MF loop empty for 1 hour. Test results after these cleanings are shown in curves 6-8 in Figure 3.

2) Steam and air

- Steam cleaning was performed by applying pressurized steam at 2.41 barg (35 psig, 126 °C) from the permeate side of the membrane for 5 minutes. The membrane was then backflushed using air and UF permeate from the permeate side as described in section 2.4. Test result after this cleaning is shown in curve 9 in Figure 3.

The results of these nine runs have been plotted in Figure 3. It demonstrates the ease of regeneration for the 1.4 µm MF membrane and its ability to consistently provide average permeate fluxes above 100 L/m²/h for bilge water containing 6 to 8 g/L O & G + detergent. With hot water cleaning on the permeate side of the membrane for 20 min at different temperature (25 to 100 °C), the first 5 runs in Figure 3 all produced average flux rates above 125 L/m²/h. Periodic backflushing was not applied to the membrane for the 6th run in Figure 3. This rapidly produced much lower flux rates. At the end of the run, the flux was 39 L/m²/h. The fouled membrane was easily regenerated with hot water at 100 °C. Run 7 produced excellent results. For the 8th run, the MF membrane was back-flushed with MF permeate instead of UF permeate. This led to a final flux of 72 L/m²/h which was much lower than the flux of 96-110 L/m²/h obtained from runs backflushed with UF permeate. This indicates the advantage of the two membrane system where a permeate having been filtered by a fine membrane having smaller pore sizes is readily available for backflushing. The membrane was then treated with steam for 5 min and then flushed with air to remove any particles that had accumulated in the backflushing process. The 9th run in Figure 3 was excellent starting at 368 L/m²/h and ending, after 23 hours, at 110 L/m²/h, producing 3,883 L/m²/day at the 8 g/L feed concentration.

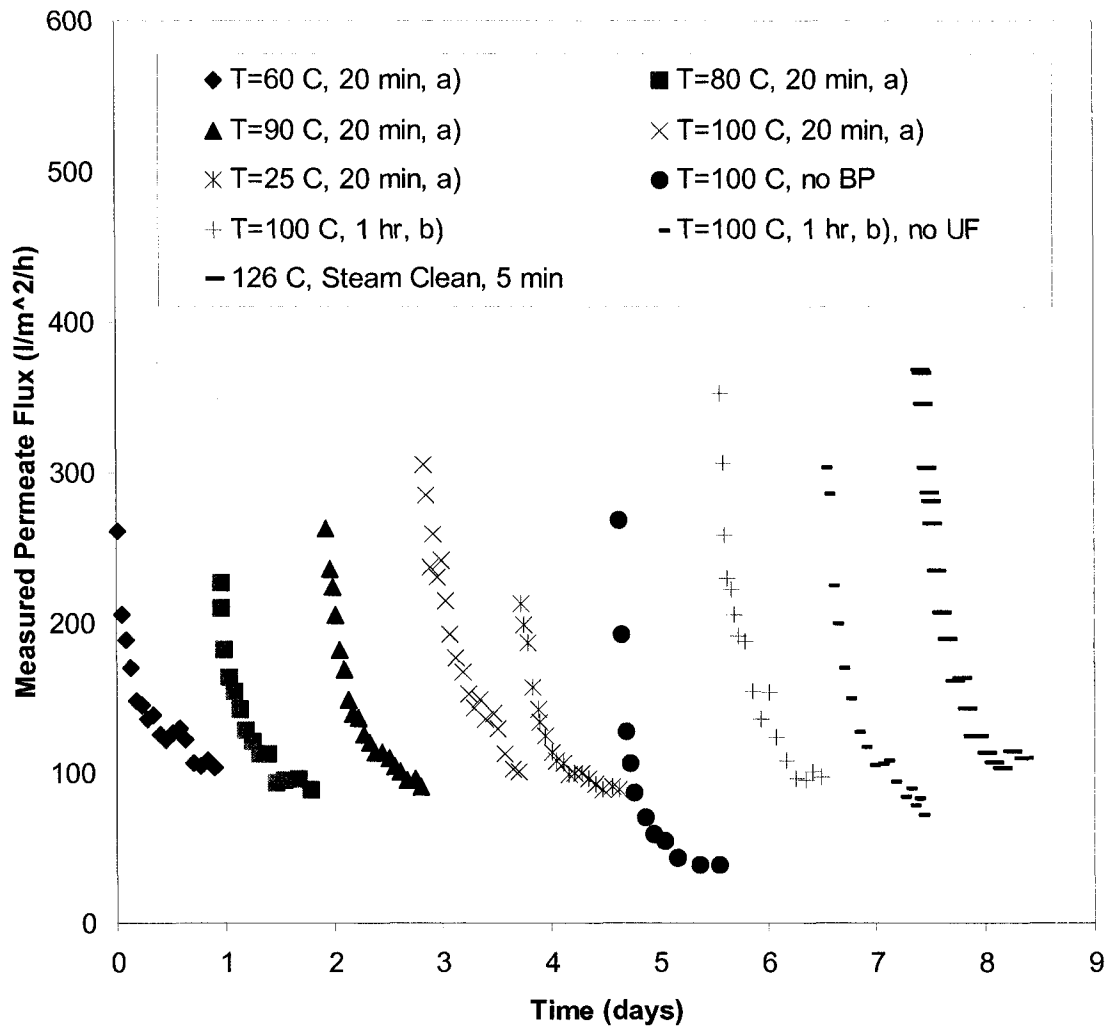

Figure 3: Plot of the measured permeate flux vs. time in days (Measured permeate flux is for bilge water containing 6 to 8 g/L of Oil and Grease + detergent; Backflushing was performed using UF permeate except when no UF is specified).

3.3 Coalescing of oil particles in microfiltration membranes

The experimental results in sections 3.1 - 3.2 can be explained by the presence of particles and their size in the bilge water and membrane module configurations. In a recent study, Peng et al. [22] used MF membranes as pre-treatment for the ultrafiltration of oily wastewater treatment and studied the particle size distribution in synthetic bilge water. One particle distribution was centered around a size of $0.18\ \mu\text{m}$ ($0.089\ \mu\text{m}$ radius) and the larger was centered around $2.68\ \mu\text{m}$ ($1.34\ \mu\text{m}$ radius). The lower end of the larger size distribution was $1.8\ \mu\text{m}$ ($0.9\ \mu\text{m}$ radius).

For the 1.4 membranes, the 0.18 micron particles present in synthetic bilge water are smaller than the membrane pores. These particles can enter the pores of the membranes blocking them eventually. Peng et al. [22] concluded that by pre-treating the oily wastewater with a large pore MF membrane operated with backflushing, the oils are partially coalesced in the pores of the membrane. This suggests that membrane flux decline was due to the coalescing of oil particles in the membrane pores. By applying steam and pressurized air from the permeate side of the membrane, the coalesced oil droplet can be removed from the pores and the flux regained. Figure 4 shows membrane with standard filter cake and with oils coalesced in the pores.

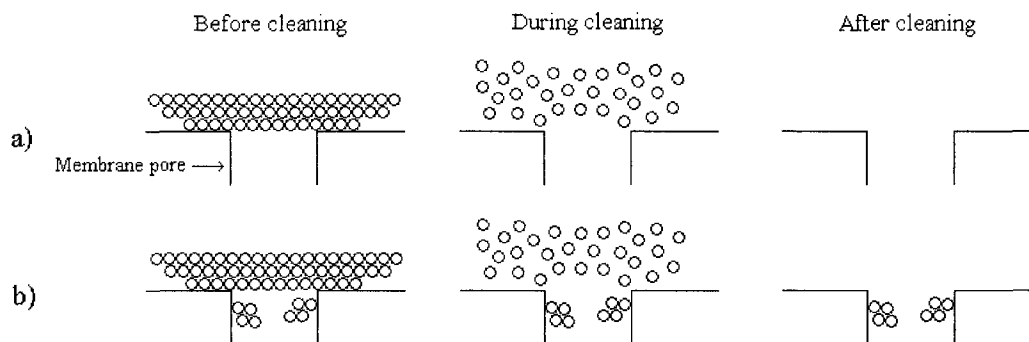

Figure 4: Fouling of membrane in this study. a) Standard filter cake; b) Cake and coalesced oils inside the pores.

3.4 Modeling of cleaning runs

3.4.1 Membrane fouling models

Traditionally, there are four classical filtration models for constant pressure filtration: the complete blocking model, the intermediate blocking model, the standard blocking model and the cake filtration model [24]. These models are based on the general equation as [24]:

$$\frac{d^2t}{dV^2} = k \left(\frac{dt}{dV}\right)^n \quad (3)$$

where t is the filtration time, V is the filtrate volume, k is the fluid consistency index and the exponent n characterizes different filtration models. The complete blocking model ($n=2$) assumed that each particle reaching the membrane seals the pores and the particles are not superimposed one upon the other. The intermediate blocking model ($n=1$) assumes every particle does not block a pore; in this scheme, particles can settle onto other particles and block a pore. In the standard blocking model ($n=1.5$), it is assumed that the pore volume decreases proportionally with filtrate volume by particle depositing on the pore walls. In the cake filtration model ($n=0$), it is assumed that the flux decline is due to the accumulation of a cake at the surface of the membrane and that cake thickness increases proportionally with the volume of permeate produced.

Ho and Zydney [25] developed a generalized approach to determine membrane flux decline. They studied effect of membrane morphology on protein fouling using microfiltration membranes. A combined pore blockage and cake filtration model was used to describe the rate of flux decline arising from simultaneous pore blockage and cake formation [25]. This model described that the initial fouling is due to pore blockage and the subsequent fouling is due to the growth of a protein cake or deposit over the initially blocked regions.

The four different membrane filtration mechanisms for constant pressure filtration and the combined model are summarized in Table 3.

Table 3: Five different membrane filtration models.

Model	Constant	Equation
Complete blocking	$K_{block} = \frac{\alpha_{block} A J_0 C_b}{N_0}$	$\frac{J_v}{J_0} = \exp(-K_{block} t) \quad (4)$
Intermediate blocking	$K_{inter} = \frac{\sigma_{inter} \Delta P}{\mu R_{inter} J_0}$	$\frac{J_v}{J_0} = (1 + K_{inter} t)^{-1} \quad (5)$
Pore constriction	$K_{constriction} = \frac{\alpha_{pore} A J_0 C_b}{\pi r_p^2 \delta_m}$	$\frac{J_v}{J_0} = (1 + K_{constriction} t)^{-2} \quad (6)$
Cake filtration	$K_{cake} = \frac{2 \alpha_{cake} J_0 C_b}{R_m}$	$\frac{J_v}{J_0} = (1 + K_{cake} t)^{-1/2} \quad (7)$
Combined model	$K_1 = \frac{\alpha \Delta P C_b}{\mu R_m}$ $K_2 = \frac{2 f' R' \Delta P C_b}{\mu R_m^2}$ $K_3 = \frac{R_{p0}}{R_m}$	$\frac{J_v}{J_0} = \exp(-K_1 t) + (1 + K_3)^{-1}$ $\times [1 + K_2 t (1 + K_3)^{-2}]^{-1/2} \times [1 - \exp(-K_1 t)]$ <p style="text-align: right;">(8)</p>

Where J_v is filtrate flux, J_0 is initial filtrate flux through the clean membrane; K_{block} is constant in complete blocking model, α_{block} provides a measure of the pore blockage efficiency; K_{inter} is constant in intermediate blocking model, σ_{inter} is blocked area per unit filtrate volume; $K_{constriction}$ is constant in pore constriction model, α_{pore} is pore constriction efficiency; K_{cake} is constant in cake filtration model, α_{cake} is specific cake resistance; K_1 , K_2 and K_3 are constants in the combined model.

3.4.2 Effect of cleaning temperature

Figure 5 shows the results obtained with the KOCH 1.4 μm membrane after cleaning with hot water or steam at different temperatures. The KOCH 1.4 μm membrane was used as the MF membrane in these runs. The results indicate an increase in permeate production with regeneration temperature.

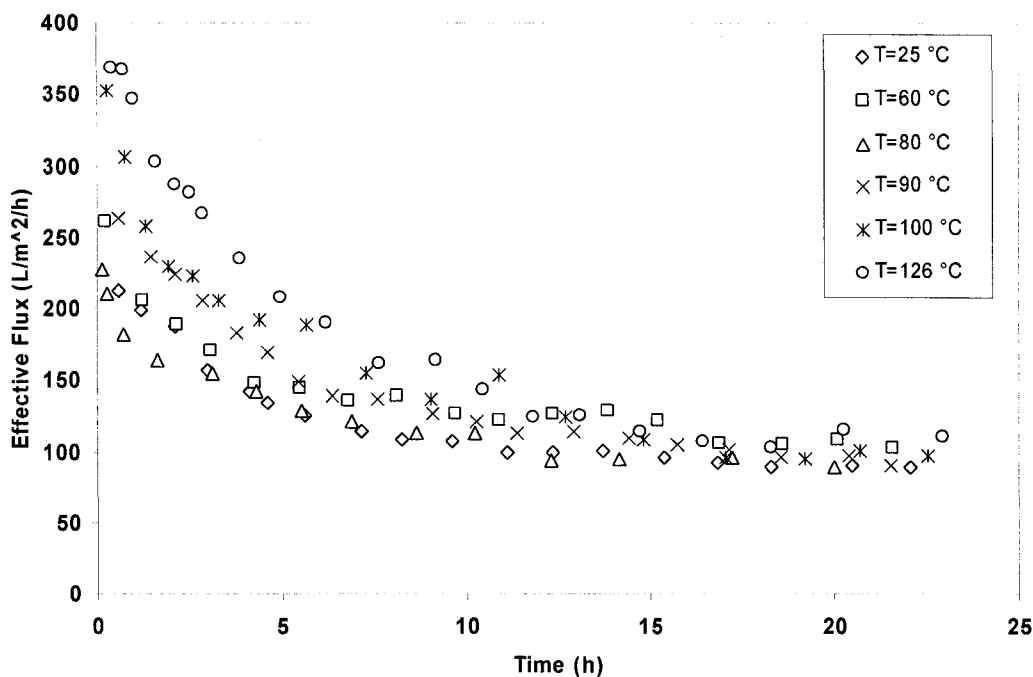

Figure 5: Flux vs. Time for the KOCH 1.4 μm membranes after cleaning at different temperatures.

For the purpose of comparison, the permeate fluxes of all the runs were predicted using the models described in section 3.4.1. Table 4 shows the cleaning temperature, the sum of square of residuals and Root Mean Squared Error (RMSE) defined as the difference between the observed flux and the predicted flux squared for the five models listed in Table 4. Figure 6 shows the results of applying the different models to the KOCH 1.4 μm membrane after steam cleaning. The filtration mechanisms of these membrane runs can be estimated from the modeling results.

Table 4: Modeling results for the KOCH 1.4 μm membranes.

Cleaning temperature (°C)	Sum of square of residuals/Root Mean Squared Error				
	Complete blocking	Intermediate blocking	Pore constriction	Cake filtration	Combined model
25	15491/29.3	4676/16.1	8816/22.1	1041/7.6	<u>862/6.9</u>
60	31350/42.9	15798/30.5	23263/37.0	7289/20.7	<u>709/6.5</u>
80	14550/32.3	36382/51.0	36382/51.0	36446/51.0	<u>820/7.7</u>
90	23189/34.0	4917/15.7	11413/23.9	695/5.9	<u>563/5.3</u>
100	16375/31.0	7910/21.6	17082/31.7	1667/9.9	<u>1649/9.8</u>
126 (steam)	20971/32.4	2222/10.5	7569/19.4	4443/14.9	<u>726/6.0</u>

- The underlined sum of squares of residuals represents the model having the best fit.

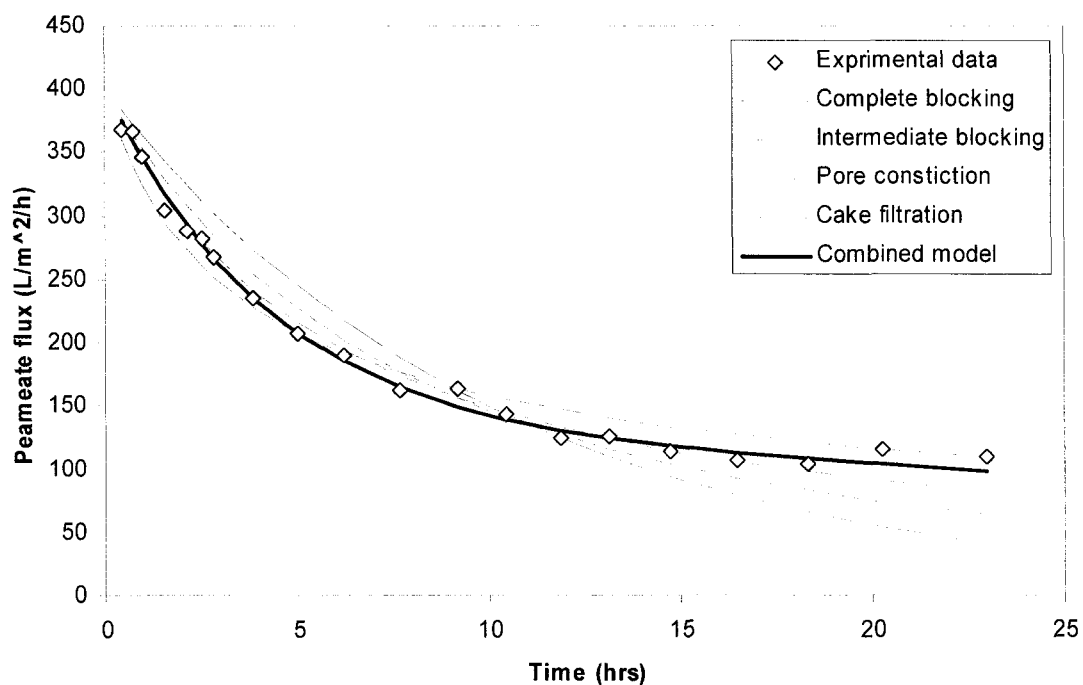

Figure 6: Plot of permeate flux vs. time for the KOCH 1.4 μm membrane after steam cleaning.

It was found that the experimental results are in good agreement with the predicted combined model. The results in Figure 5 indicate that the greatest benefits are for regenerations performed at the higher temperatures of 100 and 126 °C. This indicates that the particles present in membrane pores were most likely coalesced free oil or large micelles. Used free oil is rather viscous and is more easily flushed out of membrane pores at higher temperatures.

The procedure involving steam, air backflushing followed by UF permeate was very effective in removing coalesced oil from these membranes pores. This was also evidenced by visual observations of the carbon tube before and after steam cleaning. After a typical run, the MF tube was impregnated with sooty oil, that had a characteristic used oil smell. The steam-cleaned membrane had little if any smell and a grey, mat appearance as observed with the new “as received” carbon tubes.

The results in Table 4 and Figure 6 show that the filtration mechanism for the KOCH 1.4 µm membrane is the combined model. The modeling of the flux decline in the following sections was based on the combined model.

3.4.3 Hot water cleaning with and without backflushing

Figure 7 shows the results of hot water cleaning at 100 °C for the KOCH 1.4 µm membrane with and without backflushing. It can be found that experimental results are in good agreement with the combined model prediction.

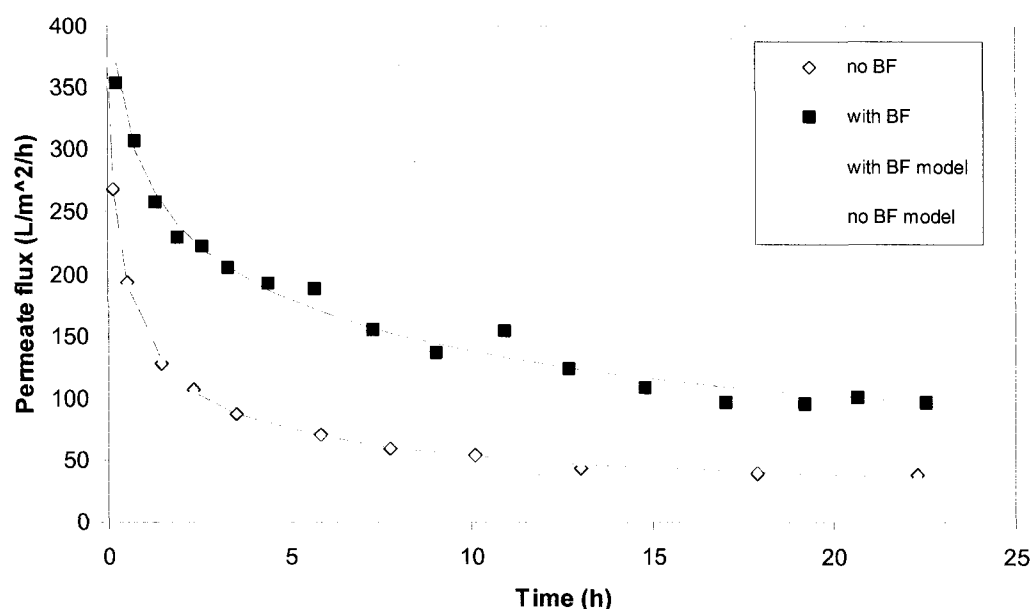

Figure 7: Permeate flux vs. Time for the KOCH 1.4 μm membrane ($T=100\text{ }^{\circ}\text{C}$). The combined model was used to fit to the above data.

3.4.4 Optimal cleaning times

Figure 8 and Table 5 show the results of the predicted optimal cleaning cycle times based on the combined model using the parameters. For the hot water and steam cleaning methods, the optimal cleaning intervals were found to be in the range of 1.6 to 2.2 hours. For the steam cleaning run, the highest effective flux (296.4 $\text{L}/\text{m}^2/\text{h}$) was found to be after 2 hours of cleaning. For the room temperature ($25\text{ }^{\circ}\text{C}$) cleaning run, the highest effective flux (173.8 $\text{L}/\text{m}^2/\text{h}$) was found to be after 2.2 hours of cleaning. The peaks of the effective fluxes increased with the increase in temperature. For the chemical cleaning run, the highest effective flux (143.3 $\text{L}/\text{m}^2/\text{h}$) was found to be 7.4 hours after the previous run. These results indicate that hot water and steam cleanings are more effective than chemical cleaning in this application. This is because hot water and steam cleanings can be performed online while chemical cleaning needs to be performed in a separate loop. Normally, it takes 20 min to perform an online steam cleaning and air backflushing while it takes 2 hours to perform chemical cleaning. Compared to chemical cleaning, hot water and steam cleanings are simple and less time-consuming.

Figure 8 also shows that for all the runs, effective fluxes reached steady-state after about 20 hours of operation, indicating that backflushing should be performed before 2.2 hours to obtain these substantial flux improvements.

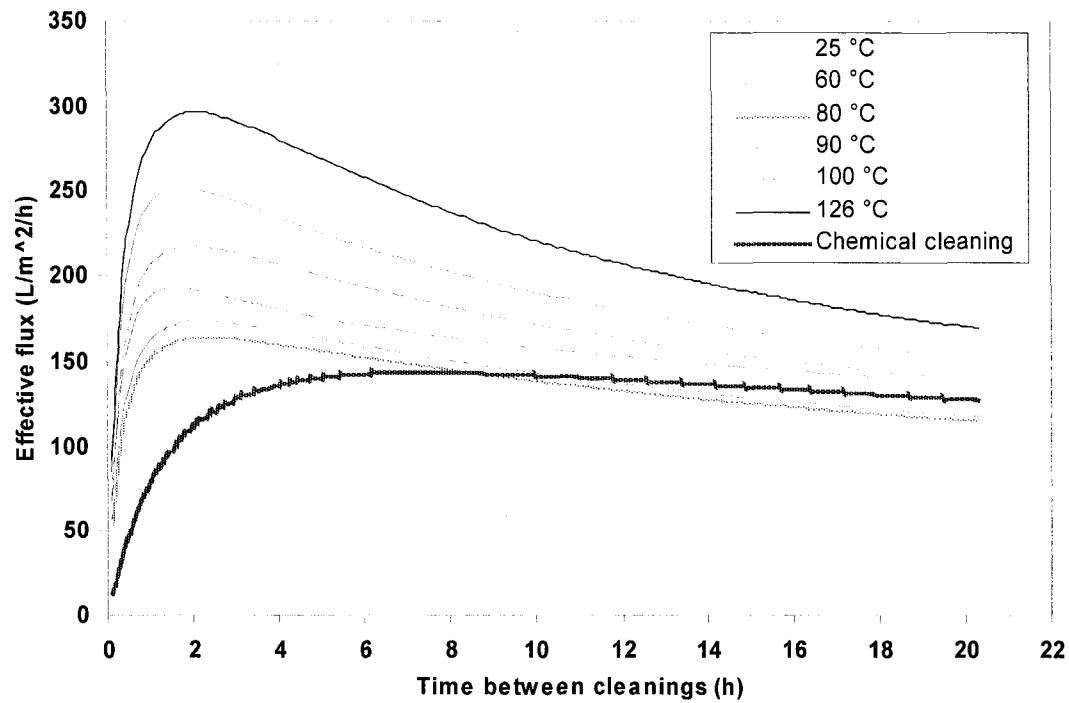

Figure 8: Effective flux vs. Time between cleanings for the KOCH 1.4 μm membranes for a 20 min physical cleaning time and a 2 hours chemical cleaning time.

Table 5: Optimal cleaning time with different cleaning methods.

Temperature ($^{\circ}\text{C}$)	Time after cleaning (h)	Effective flux ($\text{L}/\text{m}^2/\text{h}$)
25	2.2	173.8
60	1.6	192.8
90	1.7	217.3
100	1.7	252.1
126	2	296.4
Chemical Cleaning at 25 $^{\circ}\text{C}$	7.4	143.3

4. Conclusions

1. Environmentally friendly cleaning methods, such as hot water heating, steam cleaning and air backflushing were found effective in regenerating membrane flux for large pore KOCH carbon membranes. The membranes retained their flux with proper cleaning.

2. Fouling of the large pore KOCH carbon microfiltration membranes was found to be the presence of coalesced oil droplets in membrane pores. The membrane can be cleaned by applying pressurized air to remove the oil droplets from the permeate side of the membranes.

3. Experimental results in this work were in excellent agreement with a combined pore blockage and cake filtration model.

4. Optimal cleaning time for the KOCH 1.4 μm membranes in this study was found to be in the range of 1.6 to 2.2 hours after previous cleanings.

5. List of symbols

A	surface area of the membrane (m^2)
C_b	bulk concentration (kg/m^3)
d	membrane pore diameter (μm)
J_0	initial filtrate flux through the clean membrane ($\text{L}/\text{m}^2/\text{h}$)
J_v	filtrate flux ($\text{L}/\text{m}^2/\text{h}$)
K_1	constant in combined model (h^{-1})
K_2	constant in combined model (h^{-1})
K_3	constant in combined model (h^{-1})
K_{block}	constant in complete blocking model (h^{-1})
K_{cake}	constant in cake filtration model (h^{-1})

$K_{constriction}$	constant in pore constriction model (h^{-1})
K_{inter}	constant in intermediate blocking model (h^{-1})
N_0	initial pore density (kg/m^3)
Δp	trans-membrane pressure (Pa)
R_m	hydraulic resistance of the membrane (m^{-1})
R_{inter}	filter resistance in intermediate blocking model (m^{-1})
r_p	pore radius (m)
t	filtration time (h)
V	filtration volume (m^3)
α_{block}	pore blockage efficiency
α_{cake}	specific cake resistance (m/kg)
σ_{inter}	blocked area per unit filtrate volume (m^2/m^3)
α_{pore}	pore constriction efficiency
δ_m	cake thickness (m)
γ	surface tension (dynes/cm)
θ	liquid-solid contact angle (°)
μ	filtrate Newtonian dynamic viscosity (Ns/m^2)

Acknowledgements

The authors gratefully acknowledge the financial support of Defence Research Establishment Atlantic (DREA).

References

- [1] L.J Zeman and A.L. Zydney, Microfiltration and Ultrafiltration: Principles and Applications, Marcel Dekker, Inc., New York, 1996.
- [2] M. Cheryan and N. Rajagopalan, Membrane Processing of Oily Streams: Wastewater Treatment and Waste Reduction, J. Membr. Sci., 151 (1998) 13.

- [3] S. Ebrahim, Cleaning and regeneration of membranes in desalination and wastewater applications: State-of-the-art, *Desalination*, 96 (1994) 225.
- [4] G.Trägårdh, Membrane cleaning, *Desalination*, 71 (1989) 325.
- [5] J.J. Sadhwani and J.M.Veza, Cleaning tests for seawater reverse osmosis membranes, *Desalination*, 139 (2001) 177.
- [6] O. Wallberg, Ann-Sofi Jönsson and P. Wickström, Membrane cleaning – a case study in a sulphite pulp mill bleach plant, *Desalination*, 141 (2001) 259.
- [7] G. Zhang and Z. Liu, Membrane fouling and cleaning in ultrafiltration of wastewater from banknote printing works, *J. Membr. Sci.*, 211 (2003) 235.
- [8] A. Weis, M.R. Bird and M. Nyström, The chemical cleaning of polymeric UF membranes fouled with spent sulphite liquor over multiple operational cycles, *J. Membr. Sci.*, 216 (2003) 67.
- [9] C. Yanagi and K. Mori, Advanced reverse osmosis process with automatic sponge ball cleaning for the reclamation of municipal sewage, *Desalination*, 32 (1980) 391.
- [10] S. Takizawa, K. Fujita and K. H. Soo, Membrane fouling decrease by microfiltration with ozone scrubbing, *Desalination*, 106 (1996) 423.
- [11] Y. Matsumoto, T. Miwa, S. Nakao and S. Kimura, *J. Chem. Eng. Jpn.*, 29 (4) (1996) 233.
- [12] J.A Levesley and M. Hoare, The Effect of High Frequency Backflushing on The Microfiltration of Yeast Homogenate Suspensions for the Recovery of Soluble Proteins, *J. Membr. Sci.*, 158 (1999) 29.
- [13] B.S.Kim and H.N. Chang, Effects of Periodic Backflushing on Ultrafiltration Performance, *Bioseparation*, 2 (1991) 23.

- [14] S. Vigneswarne, S. Boonthanon and H. Prasanthi, Filtration Backwash Recycling Using Crossflow Microfiltration, *Desalination*, 106 (1996) 31.
- [15] P. Srijaroonrat, E. Julien and Y. Aurelle, Unstable Secondary Oil/Water Emulsion Treatment Using Ultrafiltration: Fouling Control by Backflushing, *J. Membr. Sci.*, 159 (1999) 11.
- [16] S. Natasuka, I. Nakate and T. Miyano, Drinking Water Treatment by Using Ultrafiltration Hollow Fiber Membranes, *Desalination*, 106 (1996) 55.
- [17] A. Maartens, E.P. Jacobs and P. Swart, UF of pulp and paper effluent: membrane fouling-prevention and cleaning, *J. Membr. Sci.*, 209 (2002) 81.
- [18] M.J. Munoz-Aguado, D.E. Wiley and A.G. Fane, Enzymatic and detergent cleaning of a polysulfone ultrafiltration membrane fouled with BSA and whey, *J. Membr. Sci.*, 117 (1996) 175.
- [19] M.A. Argüello, S. Álvarez, F.A. Riera and R. Álvarez, Enzymatic cleaning of inorganic ultrafiltration membranes used for whey protein fractionation, *J. Membr. Sci.*, 216 (2003) 121.
- [20] Z. Allie, E.P. Jacobs, A. Maartens and P. Swart, Enzymatic cleaning of ultrafiltration membranes fouled by abattoir effluent, *J. Membr. Sci.*, 218 (2003) 107.
- [21] ASTM D1141-90, Standard Specification for Substitute Ocean Water, *Dod Index of Specifications and Standards*, Canada, November 1992.
- [22] H. Peng, A. Y. Tremblay and D. Veinot, The use of backflushed coalescing microfiltration as a pretreatment for the ultrafiltration of bilge water, *Desalination*, 181 (2005) 109.
- [23] M. C. Porter, *Handbook of industrial membrane technology*, Park Ridge, N.J., U.S.A., 1990.

- [24] J. Hermia, Constant Pressure Blocking Filtration Laws: Applications to Power-law Non-newtonian Fluids, *Trans. Inst. Chem. Eng.*, 60 (1982) 183.
- [25] C.C. Ho and A.L. Zydney, A combined pore blockage and cake filtration model for protein fouling during microfiltration, *J. Colloid Interf. Sci.*, 232 (2000) 389.

CHAPTER VII

The study of filtration mechanism in the treatment of bilge water using ultrafiltration and microfiltration.

H. Peng, A.Y. Tremblay*

*University of Ottawa, Department of Chemical Engineering
Ottawa, ON, Canada*

*Corresponding author

André Y. Tremblay

Tel.: +1-613-562-5800 ext. 6108; Fax: +1-613-562-5172

E-mail address: tremblay@uottawa.ca

Article will be submitted for publication.

CHAPTER VII (Paper 6)

The study of filtration mechanism in the treatment of bilge water using ultrafiltration and microfiltration.

H. Peng, A.Y. Tremblay*

*University of Ottawa, Department of Chemical Engineering
Ottawa, ON, Canada*

*Corresponding author.

E-mail address:

Abstract

Filtration mechanisms were studied in the treatment of synthetic bilge water using ultrafiltration (UF) and microfiltration (MF) membranes. Various pore size multi channel tubular ceramic membranes were employed in this study. Experimental results were investigated using four classical filtration models and a combined model. The filtration mechanism for the membranes tested was found to fit the combined model, which assumes that the initial fouling is due to pore blockage and the subsequent fouling is due to the growth of a cake or deposit over the initially blocked regions. The results were further interpreted by membrane pore size, membrane module configuration, the presence of particulates and emulsified oil in this particular oily salty wastewater.

Keywords: Filtration mechanism; Microfiltration; Ultrafiltration; Bilge water; Pore size

1. Introduction

Membrane fouling occurs due to particle-particle and particle-membrane interactions. Fouling causes a decline in permeate flux and a change in membrane selectivity. Membrane fouling remains a poorly understood phenomenon. Early investigations on filtration mechanism were done by Hermans and Bredée [1]. Hermia [2] developed the constant pressure blocking filtration laws and proposed the following four filtration mechanisms: complete pore blocking, intermediate pore blocking, standard blocking and cake filtration. Since then, a number of workers have published their filtration

mechanism research results on various topics. Bowen et al. [3] investigated filtration mechanisms using different pore size membranes during dead-end microfiltration of bovine serum albumin (BSA) solutions. Similar work was done by Iritani and co-workers [4]. Ruohomäki and Nyström [5] also used these models to analyze the flux of humic acid (Aldrich) through a 0.7 μm pore size ceramic capillary filter. Their study indicated that at pH 4 and 8.5, the best fit to the data was the standard blocking model and for humic acid solutions in the presence of ferric ions, data were in best agreement with the cake filtration model. A recent study performed by Yuan and co-workers [6] analyzed humic acid fouling during microfiltration using a pore blockage-cake filtration model. They found that during fouling of an Aldrich humic acid through 0.2 μm pore size track-etched membranes, the initial fouling is due to pore blockage caused by the physical deposition of large humic acid aggregates on the surface of the membranes, then a humic acid deposit or cake begins to form on those regions of the membranes. The filtrate flux will approach a steady-state value at long filtration times. Kosvintsev et al. [7] studied microfiltration of near monosized latex particles on track-etched filters and identified three separate filtration stages. Fratila-Apachitei et al. [8] investigated ultrafiltration of secondary effluent from refinery and petrochemical wastewater treatment plant. A gradual change in blocking mechanism from complete blocking to intermediate blocking and cake filtration was observed. It was found that membrane morphology has more impact on the fouling rate than membrane pore size. Ohya and co-workers [9] showed the effects of the pore size in porous glass tube microfiltration membranes on separation mechanisms using oil-in-water emulsion. They found that the blocking filtration mechanisms were different for different pore size membranes and the transition time of separation mechanism was of the same value regardless of the membrane pore size. Arnot et al. [10] also studied microfiltration of oily-water emulsions and demonstrated different mechanisms for cross-flow and dead-end operations.

Significant work on fouling mechanism has been done by Ho and Zydney [11-13]. They have recently developed a generalized approach to determine the flux decline and studied effect of membrane morphology on protein fouling using microfiltration

membranes. A combined pore blockage and cake filtration model was used to describe the rate of flux decline arising from simultaneous pore blockage and cake formation. A more recent study performed by Ho and Zydney [14] concluded that the underlying morphology and structure of the microfiltration membrane can have a significant effect on system capacity by altering the rate and extent of fouling. Membranes with highly interconnected pores show much slower rate of flux decline than membranes with straight-through pores or with composite structures.

In this study, separation of synthetic bilge water was carried out using ceramic UF and MF membranes. The filtration mechanisms of various pore size membranes for this particular oily salty wastewater were investigated using the four classical filtration models and the combined model.

2. Theory

Traditionally, there are four classical filtration models for constant pressure filtration: the complete blocking model, the intermediate blocking model, the standard blocking model and the cake filtration model [2]. These models are based on the general equation as [2]:

$$\frac{d^2t}{dV^2} = k \left(\frac{dt}{dV} \right)^n$$

where t is the filtration time, V is the filtrate volume, k is the fluid consistency index and the exponent n characterizes different filtration models. The complete blocking model ($n=2$) assumed that each particle reaching the membrane seals the pores and the particles are not superimposed one upon the other. The intermediate blocking model ($n=1$) assumed every particle does not block a pore; in this scheme, particles can settle on to other particles and block a pore. In the standard blocking model ($n=1.5$), it is assumed that the pore volume decreases proportionally with filtrate volume by particle depositing on the pore walls. In the cake filtration model ($n=0$), it is assumed that the

flux decline is due to the accumulation of a cake at the surface of the membrane and that cake thickness increases proportionally with the volume of permeate produced.

A combined pore blockage and cake filtration model has been developed recently and used to investigate filtration mechanisms for protein fouling during microfiltration [12]. This model described that the initial fouling is due to pore blockage and the subsequent fouling is due to the growth of a protein cake or deposit over the initially blocked regions.

The four different membrane filtration mechanisms for constant pressure filtration and the combined model are summarized in Table 1.

Table 1: Five different membrane filtration models

Model	Constant	Equation
Complete blocking	$K_{block} = \frac{\alpha_{block} A J_0 C_b}{N_0}$	$\frac{J_v}{J_0} = \exp(-K_{block} t)$
Intermediate blocking	$K_{inter} = \frac{\sigma_{inter} \Delta P}{\mu R_{inter} J_0}$	$\frac{J_v}{J_0} = (1 + K_{inter} t)^{-1}$
Pore constriction	$K_{constriction} = \frac{\alpha_{pore} A J_0 C_b}{\pi r_p^2 \delta_m}$	$\frac{J_v}{J_0} = (1 + K_{constriction} t)^{-2}$
Cake filtration	$K_{cake} = \frac{2 \alpha_{cake} J_0 C_b}{R_m}$	$\frac{J_v}{J_0} = (1 + K_{cake} t)^{-1/2}$
Combined model	$K_1 = \frac{\alpha \Delta P C_b}{\mu R_m}$ $K_2 = \frac{2 f' R' \Delta P C_b}{\mu R_m^2}$ $K_3 = \frac{R_{p0}}{R_m}$	$\frac{J_v}{J_0} = \exp(-K_1 t) + (1 + K_3)^{-1}$ $\times [1 + K_2 t (1 + K_3)^{-2}]^{-1/2} \times [1 - \exp(-K_1 t)]$

Where J_v is filtrate flux, J_0 is initial filtrate flux through the clean membrane;

K_{block} is constant in complete blocking model, α_{block} provides a measure of the pore

blockage efficiency; K_{inter} is constant in intermediate blocking model, σ_{inter} is blocked area per unit filtrate volume; $K_{constriction}$ is constant in pore constriction model, α_{pore} is pore constriction efficiency; K_{cake} is constant in cake filtration model, α_{cake} is specific cake resistance.

In order to extend these simple filtration equations to cross-flow systems, it is necessary to account for the additional hydrodynamic and intermolecular forces on the particle and the effects that such forces have on the rate of particle deposition. Since the actual analysis of the hydrodynamic and intermolecular forces can be quite complex, the typical approach is to simply consider the effect of the effective velocity associated with the mass transfer back into the bulk solution (J^*).

In the early stages of a filtration run and until a steady state flux is reached, $J_v \gg J^*$. Particle deposition and clogging dominate membrane transport. In this situation, permeate flux decline can be modeled using the equations listed in Table 1. It is proposed in this work to identify the type of fouling mechanism affecting the treatment of bilge water using various membranes by fitting permeate flux decline curves to the four models identified in Table 1.

3. Experimental

3.1 Bilge water preparation

Synthetic bilge water was prepared from constituents described in a study performed by the Canadian Navy [15]:

- i) 2000-mg/L oils,
- ii) 500-mg/L detergents and surfactants, and
- iii) 50/50 mixture of fresh water + seawater (approximately 99.75%).

This formed the basis for the makeup of the standard bilge water solution used in most tests. The oils were composed of the following:

- i) 50% naval distillate (diesel fuel),
- ii) 40% used naval diesel engine lubricating oil, and
- iii) 10% hydraulic oil.

The detergents and surfactants were composed of the following:

- i) 90% oil and grease detergent (CLEANBREAK)
- ii) 10% corrosion removal compound (OSTREM Rust Stain Remover).

Synthetic ocean water was prepared according to “Standard Specification for Substitute Ocean Water”, ASTM D1141-90 (1992) [16].

3.2 Membranes

TAMI ceramic membranes (TAMI Industries, Nyons, France) are multi channel tubular ceramic membranes. Table 2 shows membrane characteristics.

Table 2: TAMI Ceramic Membrane Characteristics

Name	Daisy	Dahlia
Membrane configuration	Tubular	Tubular
Inside diameter, mm	6	2.5
Outside diameter, mm	25	25
Number of channel	8	39
Surface area, m ²	0.2	0.5
Length, ft	4	4
Membranes tested: Pore size (µm) or MWCO (kDaltons)	1.4, 0.8 & 0.07 micron and 300 & 150 kD	50 kD

3.3 Experimental set-up

Membrane pilot tests were performed in the system shown in Figure 1. Two pumps were employed in the system; one acted as a feed pump feeding bilge water to the membrane loop, a second pump was used to circulate feed in the loop. The contents of

the feed tank were continually mixed to prevent the de-phasing of the bilge water. Permeate from the membrane loop was collected in a small 8 L permeate tank. The level in the tank was monitored using a computer to determine permeate flowrate. The temperature of the system was controlled by a water-cooled coil in the feed tank. A platinum RTD (Resistance Temperature Detector) probe placed in the membrane loop provided an accurate measure of the feed temperature. A computer operated ON/OFF pneumatic valve controlled the flow of water through the coil in the tank. Once the temperature in the system reached its set point, the system was able to maintain the temperature of the feed solution within $\pm 0.1^\circ\text{C}$ of the set point.

The temperature, pressure, flux of permeate and retentate were graphically displayed on the PC screen and recorded. LABVIEW software (National Instruments) was used to control the system and acquire data.

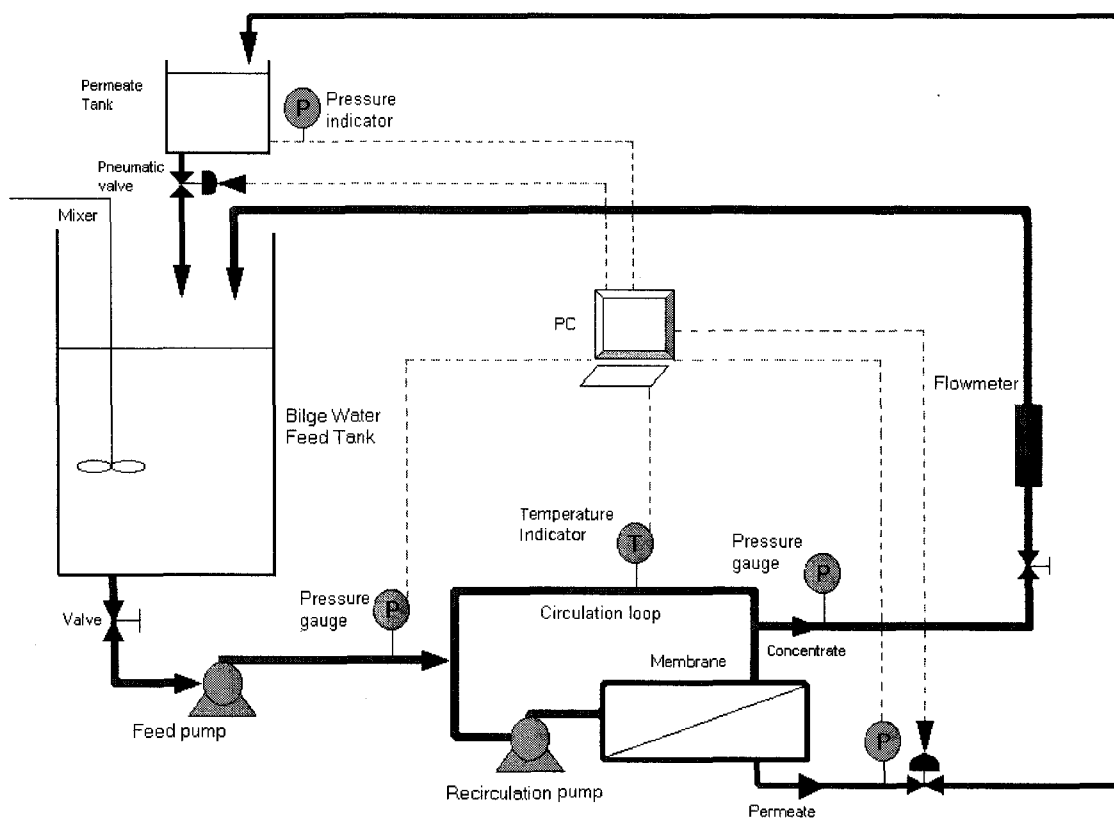

Figure 1: Schematic diagram of the pilot-scale membrane system.

3.4 Experimental procedure and analytical methods

All pilot scale runs were carried out at a cross-flow rate of 5 to 6 m/s. A test volume of 100 L synthetic bilge water was prepared at room temperature and mixed in the feed tank for several hours before each run. The new as received large pore size TAMI membranes (0.8 and 1.4 micron) were rinsed with water and used directly in the tests. The smaller pore size TAMI membranes (50, 150 and 300 kD) were wet with isopropanol prior to use in order to displace any air present in membrane pores. This was followed by a rinse with RO water several times until all traces of isopropanol had disappeared.

A flow meter was constructed out of a 10.2 cm x 0.5 m long PVC tube acting as a permeate tank, a pressure transducer (0-1 PSID, Cole-Parmer Instrument Company, Illinois, USA) and a pneumatic valve placed at the bottom of the tank. This type of flow meter was used due to the corrosive nature of the bilge water and the high level of particulates contained in the bilge water. The permeate tank was placed above the feed tank. At a low tank level set point, the discharge valve was closed, allowing for the permeate tank to fill. At a higher set point, the discharge valve opened and emptied the collected permeate back into the bilge water holding tank. The permeate tank level was converted to permeate volume by calibrating the relationship of the permeate tank volume and the corresponding tank level reading in the computer. The volume of permeate collected over a given sampling period corresponding to the maximum change in tank level was used to determine permeate flowrate. The permeate flux was calculated using the following formula.

$$\text{Flux} = \frac{\text{permeate volume}}{\text{membrane area} * \text{sample time}} \quad (\text{L/m}^2/\text{h})$$

The operating temperature was controlled to $35 \pm 0.1^\circ\text{C}$. For different runs, there was slight difference in temperature due to change of operating conditions such as room temperature and recovery within the membrane loop which varied slightly throughout the runs. The results of permeate flux in this work were corrected to 35°C in

accordance with ASTM standard D5090-90: Standardizing Ultrafiltration Permeate Flow Performance. The following formulate was used:

$$\text{Flux at } 35^{\circ}\text{C} = (\text{Flux @ Temp.}) * (1 + (35 - \text{Temp.}) * 0.03)$$

4. Results and discussion

4.1 Summary of experimental results

Four different filtration models described in the theory section have been applied to all the TAMI ceramic membranes tested in this work. Since the objective of this work was to differentiate between pore blocking, constriction and cake formation, modeling analysis focused on the first time the membrane was tested with bilge water. Table 3 shows the operating conditions and the sum of square of residuals defined as the difference between the observed flux and the predicted flux squared for the five models listed in Table 1. Table 4 shows the filtration constants being used for applying the filtration models. The filtration mechanisms of these membranes can be estimated from the modeling results.

Table 3: Operating conditions and sum of squares of residuals for the analysis of various filtration mechanisms described in Table 1.

Membrane (New membrane first time tested with bilge water)	Operating Conditions		Sum of square of residuals				
	TMP (psig)	Temperature (°C)	Complete blocking	Intermediate blocking	Pore constriction	Cake filtration	Combined model
50 kD	15	35	50364	48651	49486	47076	<u>87</u>
150 kD	7.34	35	1754	1536	1643	1336	<u>14</u>
300 kD	7.34	35	18249	11189	14376	6503	<u>406</u>
70 nm	15	35	50904	22009	34075	8315	<u>695</u>
0.8 μm	5	35	869629	1418630	525043	48702	<u>17239</u>
1.4 μm	5	35	110366	23372	54784	43426	<u>20710</u>

(Note: Temperature varied from 32 to 40 °C in real runs, the results in the table were corrected to 35 °C)

- The underlined sum of squares of residuals represents the model having the best fit.

Table 4: Different filtration constants for the analysis of various filtration mechanisms described in Table 1.

Membrane (New membrane first time tested with bilge water)	Complete blocking	Intermediate blocking	Pore constriction	Cake filtration	Combined model		
	K_{block} (h ⁻¹)	K_{inter} (h ⁻¹)	$K_{constriction}$ (h ⁻¹)	K_{cake} (h ⁻¹)	K_1 (h ⁻¹)	K_2 (h ⁻¹)	K_3 (h ⁻¹)
50 kD	0.028	0.035	0.016	0.090	3.117	0.051	0.184
150 kD	0.024	0.027	0.013	0.060	1.781	0.024	0.101
300 kD	0.064	0.092	0.038	0.266	1.122	0.110	0.389
70 nm	0.147	0.256	0.099	0.795	0.997	0.178	0.893
0.8 μm	0.209	2.584	0.132	1.561	2.093	1.046	0.748
1.4 μm	1.258	2.584	0.954	10.603	6.682	15.073	0

4.2 Modeling of filtration mechanisms

Experimental results in Table 3 show that, the filtration mechanism for all the TAMI ceramic membranes is the combined model. Figures 2 to 7 show the results of applying different filtration models to all the membranes being tested in this study.

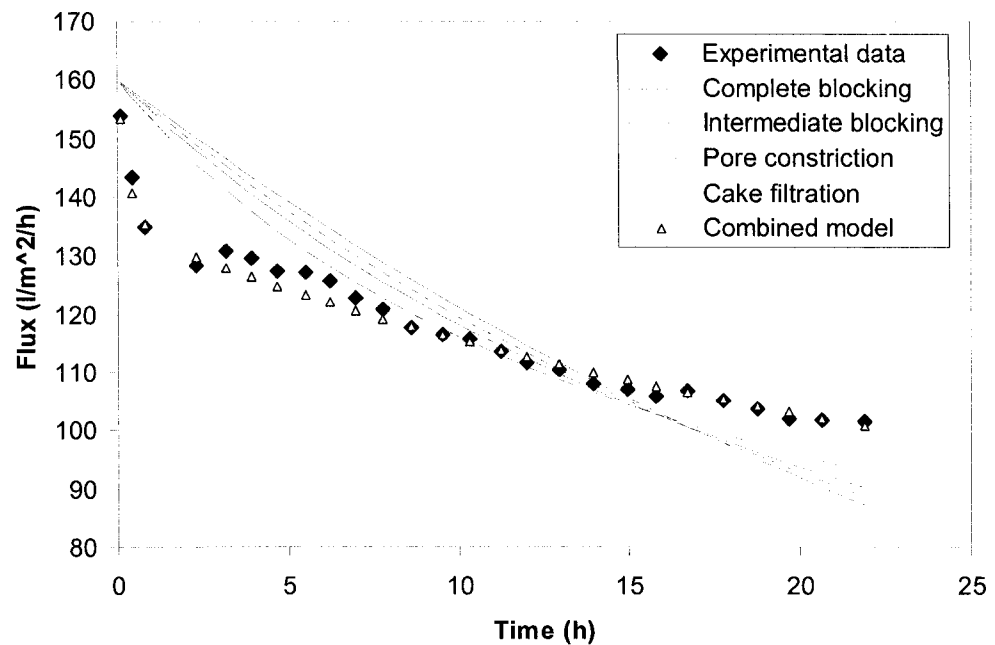

Figure 2: Plot of flux vs. time for the TAMI 50 kD membrane (TMP=15psig, 35°C, see Table 3 for sum of the square of residuals and Table 4 for filtration constants).

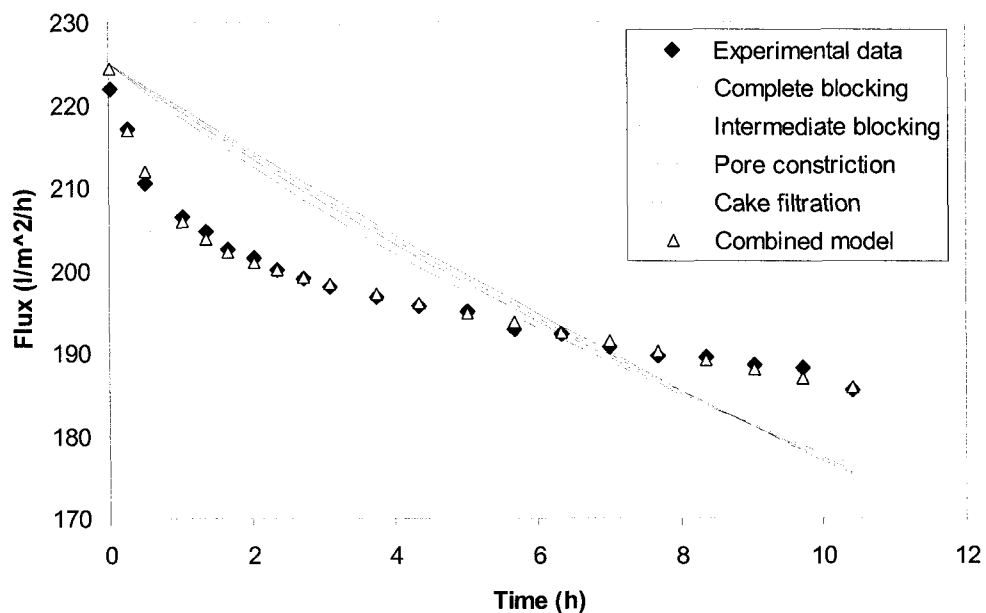

Figure 3: Plot of flux vs. time for the TAMI 150 kD membrane (TMP=7.34psig, 35°C, see Table 3 for sum of the square of residuals and Table 4 for filtration constants).

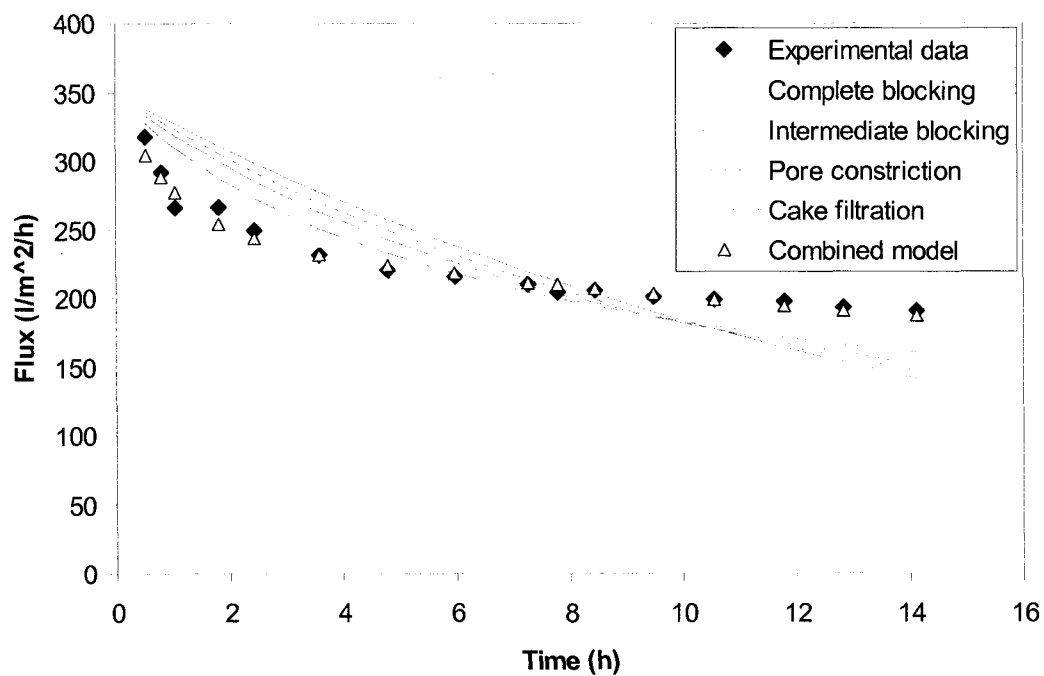

Figure 4: Plot of flux vs. time for the TAMI 300 kD membrane (TMP=7.34psig, 35°C, see Table 3 for sum of the square of residuals and Table 4 for filtration constants).

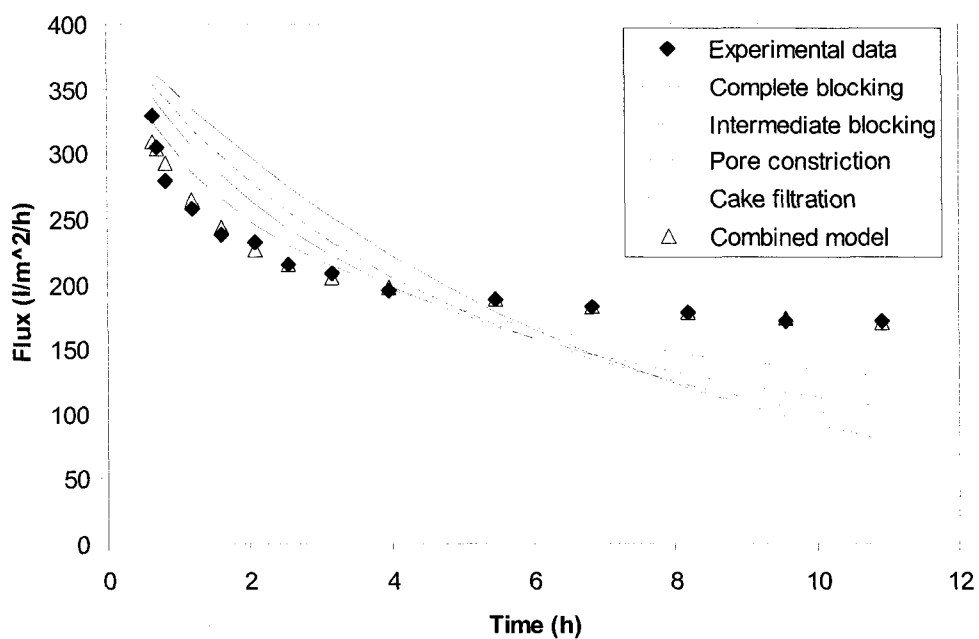

Figure 5: Plot of flux vs. time for the TAMI 70 nm membrane (TMP=15psig, 35°C, see Table 3 for sum of the square of residuals and Table 4 for filtration constants).

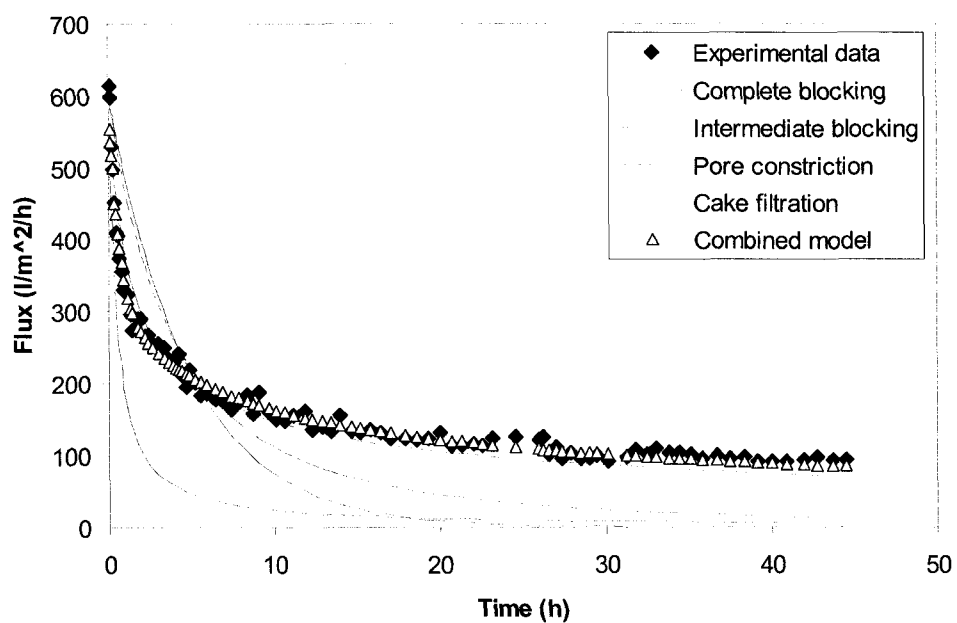

Figure 6: Plot of flux vs. time for the TAMI 0.8 micron membrane (TMP=5psig, 35°C, see Table 3 for sum of the square of residuals and Table 4 for filtration constants).

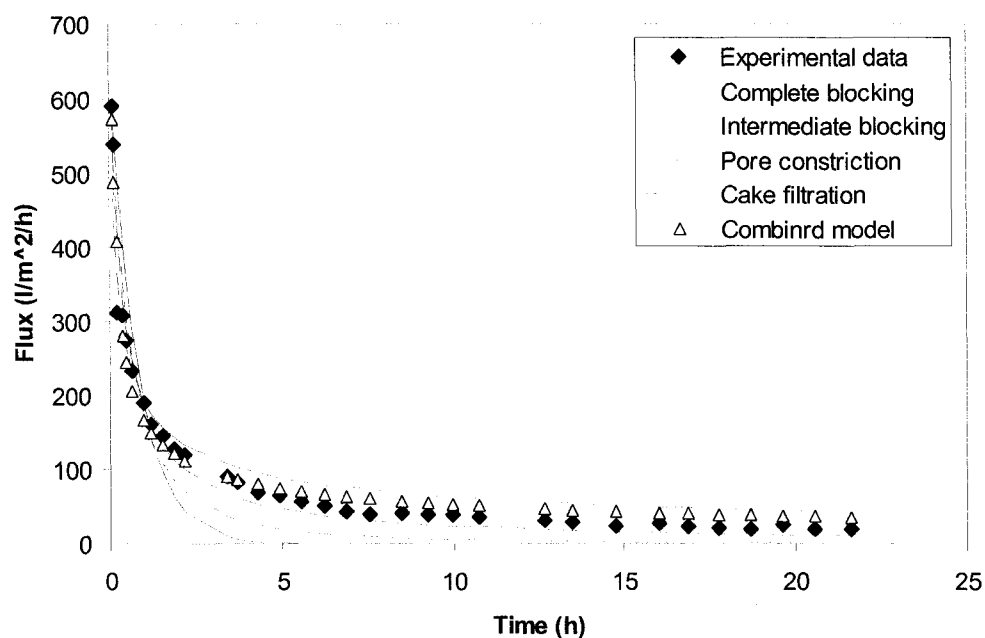

Figure 7: Plot of flux vs. time for the TAMI 1.4 micron membrane (TMP=5psig, 35°C, see Table 3 for sum of the square of residuals and Table 4 for filtration constants).

This can be explained by the presence of particle size in the bilge water and membrane module configurations. In a previous study, Peng et al. [17] used MF membranes as pre-treatment for the ultrafiltration of oily wastewater treatment and studied the particle size distribution in synthetic bilge water. One particle distribution was centered around a size of 0.18 microns (0.089 micron radius) and the larger was centered around 2.68 microns (1.34 micron radius). The lower end of the larger size distribution was 1.8 microns (0.9 micron radius).

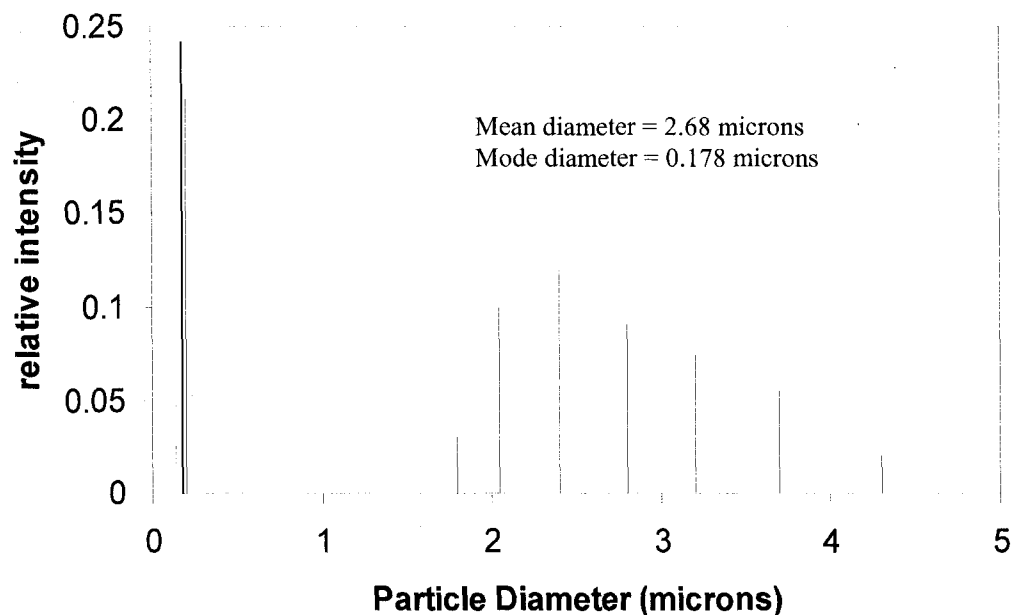

Figure 8: Particle size distribution for used oil. DLS measurements. Peaks for the smaller diameters are at 0.14, 0.178 and 0.2 microns [17].

For the 1.4 and 0.8 micron membranes, the 0.18 micron particles present in synthetic bilge water are smaller than the membrane pores. These particles can enter the pores and absorb on the surface of the membranes. It was found that the TAMI 1.4 micron membranes were irreversibly plugged and the flux could not be recovered. The TAMI membrane is a multilumen membrane with a complex support. The pore size of the support is not known and the clearance for this membrane is low. Particles passing through the selective layer of the membrane must travel through the supporting bridges of the star shaped tube before leaving the membrane. Only the outer circular area of the membrane offers good clearance while clearance for the remaining area is rather poor. This is in agreement with a recent study performed by Peng and co-workers [17].

This was also evidenced by visual observations of the TAMI tube before and after testing. It was found that for the small pore size membranes (50 kD, 150 kD and 300 kD), the exterior of the membrane tube remained clean, indicating cake filtration happened and particles did not pass through the membranes. The exterior of the

membrane tube for the larger pore size membranes (0.8 μm and 1.4 μm) was covered in a layer of sooty oil and looked dark, indicating particles (soot) enter the membrane pores and caused blocking. The passage of soot containing particulates in the multilumen membrane is easily seen where the 1.4 micron membrane has seen considerable particulate passage while this is not seen in the UF membranes [17].

5. Conclusions

Various pore size multi channel tubular ceramic UF and MF membranes were employed to study filtration mechanisms in the treatment of synthetic bilge water. The filtration mechanism for the membranes tested in this study was found to fit the combined model, which assumes that the initial fouling is due to pore blockage and the subsequent fouling is due to the growth of a cake or deposit over the initially blocked regions. This is due to the presence of particulates and emulsified oil in the oily bilge water. Membrane pore size and support structure were found to be important in the treatment of bilge water.

6. List of symbols

A	surface area of the membrane (m^2)
A_0	initial active filter membrane surface area (m^2)
C_b	bulk concentration (kg/m^3)
J_0	initial filtrate flux through the clean membrane ($\text{L}/\text{m}^2/\text{h}$)
J_v	filtrate flux ($\text{L}/\text{m}^2/\text{h}$)
J^*	effective velocity associated with the back mass transfer ($\text{L}/\text{m}^2/\text{h}$)
K_1	constant in combined model (h^{-1})
K_2	constant in combined model (h^{-1})
K_3	constant in combined model (h^{-1})
K_{block}	constant in complete blocking model (h^{-1})
K_{cake}	constant in cake filtration model (h^{-1})

$K_{constriction}$	constant in pore constriction model (h^{-1})
K_{inter}	constant in intermediate blocking model (h^{-1})
N_0	initial pore density (kg/m^3)
Δp	trans-membrane pressure (Pa)
R_m	hydraulic resistance of the membrane (m^{-1})
R_{inter}	filter resistance in intermediate blocking model (m^{-1})
r_p	pore radius (m)
t	filtration time (h)
V	filtration volume (m^3)
α_{block}	pore blockage efficiency
α_{cake}	specific cake resistance (m/kg)
σ_{inter}	blocked area per unit filtrate volume (m^2/m^3)
α_{pore}	pore constriction efficiency
δ_m	cake thickness (m)
μ	filtrate Newtonian dynamic viscosity (Ns/m^2)

Acknowledgements

The authors gratefully acknowledge the financial support of Defence R&D Canada-Atlantic (DRDC-Atlantic).

References

- [1] Hermans P.H. and H. L. Bredée, Rec. Trav. Chem. des PaysBas 54 (1935) 680.
- [2] Hermia J., Constant Pressure Blocking Filtration Laws: Applications to Power-law Non-newtonian Fluids, Trans. Inst. Chem. Eng. 60 (1982) 183.

- [3] Bowen W.R., J.I. Calvo, A. Hernández, Steps of membrane blocking in flux decline during protein microfiltration, *J. Membr. Sci.* 101 (1995) 153.
- [4] Iritani E., Y. Mukai, y. Tanaka, T. Murase, Flux decline behavior in dead-end microfiltration of protein solutions, *J. Membr. Sci.* 103 (1995) 181.
- [5] Ruohomäki K. and M. Nyström, Fouling of ceramic capillary filters in vacuum filtration of humic acid, *Filtr. Sep.* 37 (2000) 51.
- [6] Yuan W., A. Kocic, A.L. Zydney, Analysis of humic acid fouling during microfiltration using a pore blockage-cake filtration model, *J. Membr. Sci.* 198 (2002) 51.
- [7] Kosvintsev S., R.G. Holdich, I.W. Cumming, V.M. Starov, Modeling of dead-end microfiltration with pore blocking and cake formation, *J. Membr. Sci.* 208 (2002) 181.
- [8] Fratila-Apachitei L.E., M. D. Kennedy, J.D. Linton, I. Blume, J. C. Schippers, Influence of membrane morphology on the flux decline during dead-end ultrafiltration of refinery and petrochemical waste water, *J. Membr. Sci.* 182 (2001) 151.
- [9] Ohya H., J.J. Kim, A. Chinen, M. Aihara, S. I. Semenova, Y. Negishi, O. Mori, M.Yasuda, Effects of pore size on separation mechanisms of microfiltration of oily water, using porous glass tubular membrane, *J. Membr. Sci.* 145 (1998) 1.
- [10] Arnot T.C., R.W. Field, A.B. Koltuniewicz, Cross-flow and dead-end microfiltration of oily-water emulsions. Part II. Mechanisms and modeling of flux decline, *J. Membr. Sci.* 169 (2000) 1.
- [11] Ho C.C., A.L. Zydney, Effect of membrane morphology on the initial rate of protein fouling during microfiltration, *J. Membr. Sci.* 155 (1999) 261.

- [12] Ho C.C., A.L. Zydney, A combined pore blockage and cake filtration model for protein fouling during microfiltration, *J. Colloid Interf. Sci.* 232 (2000) 389.
- [13] Ho C.C., A.L. Zydney, Protein fouling of asymmetric and composite microfiltration membranes, *Ind. Eng. Chem. Res.* 40 (2001) 1412.
- [14] Ho C.C., A.L. Zydney, Effect of Membrane morphology on system capacity during normal flow microfiltration, *Biotechnol. Bioeng.* 83 (2003) 537.
- [15] Department of National Defence (DND), Technical Statement of Requirements for an Oily Water Separator System, Ottawa, Canada (July 1996).
- [16] ASTM D1141-90, "Standard Specification for Substitute Ocean Water", *Dod Index of Specifications and Standards*, Canada, (November 1992).
- [17] Peng H., A. Y. Tremblay and D. Veinot, The use of backflushed coalescing microfiltration as a pretreatment for the ultrafiltration of bilge water, *Desalination*, 181 (2005) 109.

CHAPTER VIII

DISCUSSION

The objective of this thesis was to develop a membrane based process to remove oil and grease from bilge water to non-detectable levels where it could be discharged into sensitive environments. This thesis deals with the challenge of developing a membrane based OWS system in ship-borne applications for the treatment of a difficult oily wastewater, which contains a variety of salts, used oils, detergents, and other contaminants and differs from those found in the petrochemical and automotive industries or in domestic sewage operations. The objective has been accomplished in this study through the evaluation of treatment feasibility, design and development of pilot scale membrane cascade systems, evaluation of membrane performance, development of analytical methods for oil and grease determination, investigation of environmentally friendly cleaning methods, and study of filtration mechanisms.

In the beginning of this study, we conducted a literature review on oily wastewater treatment using membrane technologies and found that membrane ultrafiltration and microfiltration are considered key technologies in this application (Zeman and Zydney, 1996; Cheryan and Rajagopalan, 1998; Gryta et al., 2001). Literature searches indicated that the application of a membrane hybrid system was able to reduce oil content to 5-15 ppm from bilge water (Karkuiski et al., 1998; Gryta et al., 2001; Tomaszewska et al., 2005).

This led us to conduct the study (Paper 1) of evaluating the treatment feasibility and performance of a MF/UF hybrid system with an objective to treat bilge water to meet coastal discharge limit (15 ppm). A cascaded membrane system consisting of a coalescing backflushed microfiltration membrane and an ultrafiltration membrane was designed, developed and evaluated. The pilot system was equipped to perform the backflushing of the MF membranes and send permeate to the UF membranes for further treatment. Two microfiltration membranes were studied; single tube carbon

membranes (KOCH Membrane Systems, Ann Arbor, Michigan, USA) and multilumen ceramic membranes (TAMI Industries, Nyons, France). Experimental results showed that membranes with a pore size below 0.2 microns can be used directly to treat bilge water. The particle size distribution of bilge water and UF membrane pore size were related to membrane performance. In a previous study on particle size distribution in synthetic bilge water (Nottegar and Tremblay, 2000), it was found that one particle distribution was centered around a size of 0.18 microns (0.089 micron radius) and the larger was centered around 2.68 microns (1.34 micron radius). The lower end of the larger size distribution was 1.8 microns (0.9 micron radius). In the presence of such particles, maximum pore blockage is expected for microfilters with pores falling in the 0.14 to 0.2 micron diameter range. Membranes having a pore size just below the value of 0.14 micron would have the best performance while those within the range are expected to be totally blocked and the larger pore sizes membranes would need backflushing to remove the gradual accumulation of particles within the pores. Experimental results in Paper 1 were in excellent agreement with these findings and indicated that membranes with a 0.2 micron pore size are not suitable in treating oily brine containing seawater due to the presence of 0.18 micron particles found in this wastewater.

Experimental results in Paper 1 showed that the pretreatment of this oily wastewater, prior to ultrafiltration, is desirable as used oils and particulates can block the feed channels of UF spiral and hollow fiber modules. Backflushing is an effective technique to reduce fouling caused by “sticky” cakes in synthetic bilge water treatment using a microfiltration membrane. The optimal backflushing cycle was determined for the single tube carbon membrane. The optimal backflushing cycle was obtained when flow was reversed for 1 % of the time during a 5 minute period. Microfiltration membranes responded well to backflushing with flux enhancements of up to 8 times compared to the case of cross-flow alone. Membrane support structure was found to be critical in enhancing flux during backflushing. Ceramic membranes with pore size less than 70 nm and backflushed single tube carbon membranes with pore size 1.4 microns followed by UF membrane had the best performance. Backflushing of MF

membranes offered flux improvements for single tube carbon membranes but not for multilumen ceramic membranes. The clearance of the support structure with respect to particulates was found to be important. The single carbon tube had a shorter path compared to the longer path of the multilumen ceramic tube. This work outlined the need for microfiltration membranes offering good particulate clearance to be used in backflushing coalescence applications. MF/UF hybrid membrane system was found to be effective in further reducing the oil and grease content of the final permeate by a factor of 12 compared to the case without ultrafiltration. In all cases, after treatment with UF membranes, the oil and grease content of the permeate was found to be below the allowable discharge limit for coastal waters.

From the experimental work in Paper 1, we gained valuable knowledge and experience in membrane system design and testing for the treatment of bilge water. This work was an important contribution, which enabled us to develop a second membrane system to conduct further research in this thesis. Based on the research findings in Paper 1, we developed a second membrane cascade for selective removal of oil to 0 ppm or non-detectable levels from bilge water while minimizing the production of brine retentate waters that must be stored onboard a ship. The major challenges here were the selection of appropriate membranes in this application and the development of appropriate analytical methods for determination of oil and grease content in treated bilge water. The presence of a high level of divalent salts in bilge water greatly complicates the removal of oil and grease down to ppm levels by membrane technologies. The conventional approach to solve this problem would be to use a reverse osmosis (RO) membrane to remove dissolved and suspended material. A recent study using an integrated UF/RO system for bilge water treatment reported that more than 90% of all cations could be removed and the obtained RO permeate was free of oil (Tomaszewska et al., 2005). However, the high osmotic pressure of seawater implies that an oily brine must be stored onboard for future discharge. Retaining the oil and letting the mono and divalent salts permeate through the membranes is a better approach. Also, it was not our intent to use RO process given the high pressure requirement and the operating cost associated with it. However, we planned to test

commercially available NF membranes to investigate if the NF process is suitable in this application.

Literature review showed that various sizes of oil droplets can be found during membrane filtration (Vladisavljević et al., 2002; Madaeni and Yeganeh, 2003; Faibish and Cohen, 2001) and a study reported that droplet coalescence in membrane pores led to nano-scale oil aggregates in the permeate (Lipp et al., 1988). It was our intent to investigate if oil droplet aggregation could be observed in this work.

In Paper 2, a pilot scale membrane cascade system was designed and evaluated using tubular MF and UF membranes in a first stage, where high levels of particulate matter are present, and Sepa® (GE Osmonics, Minnetonka, MN, USA) flow cells representing industrial spiral wound modules in the second stage. Large channel MF and UF ceramic membranes (TAMI Industries, Nyons, France) were used in the first loop while a variety of flat sheet UF (1 to 100 kD MWCO) and NF membranes (GE Osmonics, Minnetonka, MN, USA) were studied in the second stage (loop 2). Permeates obtained from the first and second stages were analyzed using an extraction procedure followed by gas chromatography. The work demonstrated that lower MWCO UF membranes used in the cascade arrangement can retain organics while allowing the passage of mono and divalent salts. It was found that this system can produce water containing below detectable levels of hexane extractable material. NF membranes were considered unsuitable in this application due to their retention of divalent salts leading to poor permeate flux performance. Lower MWCO membranes (1–5 kD) had excellent permeate fluxes ranging from 25 to 62 L/m²/h and rejections rates of hexane extractable organics were above 90%. The oil and grease concentration in the permeates from these membranes were all found to be less than 0.7 ppm ranging from 0.0 to 0.7 ppm. Higher molecular weight membranes (20–100 kD) were found to have low rejections of hexane extractable material ranging from 47.9% to 19.7%. The hexane extractable oil and grease concentrations in the permeates from these membranes were found to be 0.1 and 0.0 ppm for the corresponding 1, and 2 kD MWCO membranes. Among all the membranes tested in this work, the 2 kD GK

membrane was found to have the best performance in the second loop of the cascade system. The size of oil particles in the second loop was measured by dispersive light scattering (DLS). Nano sized particles were observed and the size of these particles was found to increase over time as a result of mixing and circulating in the second loop. Experimental results of the research conducted in this study suggested that it is possible to achieve the target of removing oil from bilge water to 0 ppm or non-detectable levels through the proper design of the membrane system, selection of appropriate membranes, determination of optimal operating parameters, and assessment of membrane performance.

Papers 3 and 4 presented the results of development of an analytical method to extract and analyze organic species at very low concentration levels for the analysis of oil and grease content found in bilge water and membrane permeate. Permeates of various membranes from a pilot scale MF/UF membrane cascade system were collected and analyzed using an extraction procedure followed by gas chromatography. Experimental results showed that solid phase extraction using ENVI-18 sorbent retained much of the organic matter found in the bilge water and could not preserve the molecular weight distribution in the oil mixture used to prepare synthetic bilge water. This was most likely due to the limited ability of the extraction solvent to remove the organic species sorbed on the SPE packing. Perhaps the use of a reverse phase having a shorter carbon chain (C4 or C8) would have permitted the release of the oil and grease. However, the mixture of diesel and lubricating oil found in bilge water has a range of hydrocarbons from C10 to C34. In addition to this, any SPE would most likely retain the organic species in the mixture to varying extent. This would have meant a loss of a very important aspect of speciation available using gas chromatography as opposed to a more general infrared (IR) detection. In conclusion, the SPE technique was not suitable for the release of oil and grease from diesel and lubricating oil mixtures. It was not acceptable as a concentration technique to characterize a mixture containing a broad range of molecular weights. n-Hexane liquid-liquid extraction technique was found to be able to preserve the molecular weight distribution of diesel and lubricating oils separated by ultrafiltration. Possible matrix effects likely caused by the presence

of a detergent (sodium salt of dodecylbenzenesulfonic acid) in the synthetic bilge water mixture were studied. It was found that a detergent concentration up to 5 g/L had no effect on the extraction of a 50 ppm diesel and lubricating oil mixture in seawater.

This work also studied the effect of membrane MWCO in separation of oil and grease. Membranes having lower MWCOs (1–5 kD) were found to have rejections for hexane extractable material ranging from 90 to 100%. The oil and grease concentration in the permeates from these membranes were all found to be less than 0.7 ppm ranging from 0.0 to 0.7 ppm. For a feed concentration of 7.7 ppm, higher MWCOs (20–100 kD) membranes were found to have low rejections of hexane extractable material ranging from 47.9% to 19.7%. It was found that removal of organic is substantially improved at a point between 5 and 20 kD. The hybrid system comprising a 300 kD small pore MF membrane and a 2 kD UF membrane was an excellent combination to remove the hexane extractable organics from bilge water to levels below the detection limit. The results were interpreted based on possible aliphatic and aromatic content of the permeates. The resulting species found in the permeate from the 1-5 kD membranes are most likely aromatic. Diesel fuels can contain between 13 to 20 % polycyclic aromatic hydrocarbons (PAHs) (Guthrie et al., 2003). Substituted di-aromatics are quite common in diesel blends and would give GC retentions that do not exhibit the periodicity of alkanes. These aromatics are also more soluble in water than alkanes of comparable molecular weight. It was found that aromatic hydrocarbons, of comparable molecular weight, have water solubilities that are 3 to 4 orders of magnitude greater than straight chain alkanes found in diesel. This led us to conclude that the permeate from the 300 kD membrane fed to the second loop was composed of both; nanosized droplets containing alkanes and PAHs, and PAHs in solution. The solubility of PAHs is above the minimum concentration of 3.7 ppm observed for all membranes above 20 kD. It is only below 5 kD that the permeate concentration drops below 1 ppm. This suggests that the alkanes are acting as carriers for the PAHs and that the sizes of these nanoparticles are between 3.7 to 7.4 nm (5 to 20 kD MWCO).

Paper 5 investigated environmentally friendly physical membrane cleaning methods, such as backflushing with hot water or steam followed by pressurized air, for the treatment of bilge water using microfiltration and ultrafiltration. Literature showed that various membrane cleaning approaches, including chemical, physical, physico-chemical and biological methods, have been used to regenerate permeate flux. The challenge in this work was to develop physical cleaning methods, which will avoid the supply, storage, disposal and handling problems caused by using chemical or bioactive agents for cleaning in ship-born applications.

The treatment of oily wastewater containing half seawater using a MF/UF hybrid system was studied in this work. It was found that fouling of KOCH carbon microfiltration membranes was due to the presence of coalesced oil droplets in membrane pores. The use of backflushed coalescing microfiltration for the pre-treatment of oily wastewaters prior to ultrafiltration is an interesting technique offering potential as a physical pretreatment method. The concept of this technique is to pre-treat oily wastewaters with a large pore microfiltration membrane operated with backflushing where the oils are partly coalesced in the pores of the membrane. The permeate from this membrane can then be treated by ultrafiltration. The coalescing membrane must eventually be regenerated in order to maintain a desirable permeate flux. This concept has been developed based on the work conducted in Paper 1. The membrane can be cleaned by applying pressurized air to remove the oil droplets from the permeate side of the membranes. Hot water heating, steam cleaning and air backflushing methods were found effective in regenerating membrane flux for large pore KOCH carbon membranes. The beneficial effects for steam cleaning were quite evident. The results were also modeled using four traditional fouling models and a combined filtration model. Modeling results in this work were in excellent agreement with a combined pore blockage and cake filtration model. They indicated that fouling of microfiltration membranes is due to the presence of oil and grease and seawater colloids in membrane pores. Optimal cycle times between physical cleanings were found to be in the range of 1.6 to 2.2 hours after previous cleanings.

In the last paper (Paper 6) of this thesis, filtration mechanisms were studied in the treatment of synthetic bilge water using ultrafiltration and microfiltration membranes. Various pore size ceramic UF and MF membranes were employed in this study. Traditionally, there are four filtration mechanisms for constant pressure blocking filtration: complete pore blocking, intermediate pore blocking, standard blocking and cake filtration (Hermia, 1982). The complete blocking model assumed that each particle reaching the membrane seals the pores and the particles are not superimposed one upon the other. The intermediate blocking model assumed every particle does not block a pore; in this scheme, particles can settle on to other particles and block a pore. In the standard blocking model, it is assumed that the pore volume decreases proportionally with filtrate volume by particle depositing on the pore walls. In the cake filtration model, it is assumed that the flux decline is due to the accumulation of a cake at the surface of the membrane and that cake thickness increases proportionally with the volume of permeate produced. A combined pore blockage and cake filtration model has been developed recently and used to investigate filtration mechanisms for protein fouling during microfiltration (Ho and Zydney, 2003). This model described that the initial fouling is due to pore blockage and the subsequent fouling is due to the growth of a protein cake or deposit over the initially blocked regions. Experimental results were investigated using four classical filtration models and a combined model. The filtration mechanism for the membranes tested was found to fit the combined model, which assumes that the initial fouling is due to pore blockage and the subsequent fouling is due to the growth of a cake or deposit over the initially blocked regions. The results were further interpreted by membrane pore size, membrane module configuration, the presence of particulates and emulsified oil in this particular oily salty wastewater.

REFERENCES

Cheryan, M. and N. Rajagopalan, "Membrane Processing of Oily Streams. Wastewater Treatment and Waste Reduction", *Journal of Membrane Science* 151 13-28 (1998).

Faibish, R.S., and Y. Cohen, "Fouling-resistant ceramic-supported polymer membranes for ultrafiltration of oil-in-water microemulsions", *Journal of Membrane Science* 185 129-143 (2001).

- Gryta, M., K.Karakulski and A.W.Morawski, "Purification of oily wastewater by hybrid UF/MD", *Wat. Res.* 35(15) 3665-3669 (2001).
- Guthrie, J., Fowler, P., Sabourin R., "Gasoline and Diesel Fuel Survey", Environment Canada report, September (2003).
- Hermia, J., "Constant Pressure Blocking Filtration Laws: Applications to Power-law Non-newtonian Fluids", *Trans. Inst. Chem. Eng.* 60 183-187 (1982).
- Ho, C.C. and A.L. Zydney, Effect of Membrane morphology on system capacity during normal flow microfiltration, *Biotechnol. Bioeng.* 83 (5) 537-543 (2003).
- Karakuiski, K., W.A.Morawski and J. Grzechulska, "Purification of bilge water by hybrid ultrafiltration and photocatalytic processes", *Separation and Purification Technology* 14 163-173 (1998).
- Lipp, P., C.H.Lee, A.G.Fane and C.J.D.Fell, "A Fundamental Study of The Ultrafiltration of Oil-Water Emulsions", *Journal of Membrane Science* 36 161-177 (1988).
- Madaeni, S.S. and M.K. Yeganeh, "Microfiltration of Emulsified Oil Wastewater", *Journal of Porous Materials* 10 131-138 (2003).
- Nottegar, M. and A.Y. Tremblay, "Bilge Water Membrane Treatment Phenomena Study", contract W7707-7-5321, report prepared for Department of National Defence (DND), Ottawa, Canada, (2000).
- Tomaszewska, M., A. Orecki, K. Karakulski, "Treatment of bilge water using a combination of ultrafiltration and reverse osmosis", *Desalination* 185 203-212 (2005).
- Vladisavljević, G.T., S. Tesch and H.Schubert, "Preparation of water-in-oil emulsions using microporous polypropylene hollow fibers: influence of some operating parameters on droplet size distribution", *Chemical Engineering and Processing* 41 231-238 (2002).
- Zeman, L.J. and A.L.Zydney, "Microfiltration and Ultrafiltration, Principles and Applications", Marcel Dekker, Inc. 331-341, 380-381, 575-576 (1996).

CHAPTER IX

CONCLUSIONS

The objective of this study was to develop a membrane based process to remove oil and grease from bilge water to non-detectable levels where it could be discharged into sensitive environments. Results of the research conducted in this study suggest that it is possible to achieve this target through the proper design of the membrane system, selection of appropriate membranes, determination of optimal operating parameters, and assessment of membrane performance.

Specifically, it was found that:

1. A pilot scale membrane hybrid system, consisting of a coalescing backflushed microfiltration membrane used as a pretreatment and an ultrafiltration membrane as a final polishing step, was found to be very effective in treating bilge water, producing permeate with oil and grease content of 6 ppm, well below the allowable discharge limit (15 ppm) for coastal waters. The use of backflushed coalescing microfiltration for the pre-treatment of oily wastewaters prior to ultrafiltration is an interesting technique offering potential as a physical pretreatment method. The concept of this technique is to pre-treat oily wastewaters with a large pore microfiltration membrane operated with backflushing where the oils are partly coalesced in the pores of the membrane. The permeate from this membrane can then be treated by ultrafiltration.
2. Backflushing is an effective technique to reduce fouling caused by “sticky” cakes in synthetic bilge water treatment using a microfiltration membrane. Membrane support structure was found to be critical in enhancing flux during backflushing. It was found that there is a need for microfiltration membranes offering good particulate clearance to be used in backflushing coalescence applications.

3. A pilot scale membrane cascade system using tubular MF and UF membranes in a first stage and flat sheet UF membranes in a second stage was found to be able to produce water containing below detectable levels of hexane extractable material in treating synthetic bilge water. In the second stage, membranes having lower MWCOs (1–5 kD) were found to have rejections for hexane extractable material ranging from 90 to 100%. Higher MWCOs (20–100 kD) membranes were found to have low rejections of hexane extractable material ranging from 47.9% to 19.7%. It was found that removal of organic is substantially improved at a point between 5 and 20 kD. Nano sized particles were observed in membrane permeates and the size of these particles was found to increase over time as a result of mixing and circulating in the second loop.

4. It was found that in analyzing permeate samples of various MWCO membranes, solid phase extraction using ENVI-18 sorbent retained much of the organic matter found in the bilge water and could not preserve the molecular weight distribution in the oil mixture used to prepare synthetic bilge water. n-Hexane liquid-liquid extraction technique was found to preserve the molecular weight distribution of diesel and lubricating oils separated by ultrafiltration.

5. Environmentally friendly physical membrane cleaning methods, such as backflushing with hot water or steam followed by pressurized air, were found effective in regenerating membrane flux for large pore KOCH carbon membranes in the treatment of synthetic bilge water using a MF/UF hybrid system. The beneficial effects for steam cleaning were quite evident in this application.

6. Filtration mechanisms were studied in the treatment of synthetic bilge water using ultrafiltration and microfiltration membranes. Experimental results were investigated using four classical filtration models and a combined model. The filtration mechanism for the membranes tested in this study was found to fit the combined pore blockage and cake filtration model.

CHAPTER X

RECOMMENDATIONS

Based on the results of this study, a number of recommendations can be provided for future research to enhance the treatment of bilge water onboard ships.

1. Further study the aggregation of nanosized particles in the permeate from the first loop and prior to treatment in the second loop.
2. At this point it is not evident that the nanoparticles are saturated with the more soluble PAHs. What is the partition coefficient between the soluble PAH and the nanoparticles? Can further mixing enhance the sorption of PAHs in the organic phase?
3. Use low aromatic diesels in ships operating in arctic waters as these more soluble aromatic fractions are the most difficult to separate down to the sub ppm to ppb level.
4. Study the separation performance of membrane systems in the treatment of bilge water containing low and non aromatic diesels.
5. Perform studies using small 2.5 inch spirals, containing 1 to 5 kD MWCO membranes, in the second loop to determine their performance and maximum recovery attainable in the second loop.
6. The use of a low MWCO UF polishing step following the existing OWS treatment should be investigated onboard a ship.
7. The optimal MWCO between 1 and 5 kD, membrane type, operating pressure and feed spacers should be determined in practice using small spiral wound modules on existing UF treatment systems onboard a ship.