

INFORMATION TO USERS

This manuscript has been reproduced from the microfilm master. UMI films the text directly from the original or copy submitted. Thus, some thesis and dissertation copies are in typewriter face, while others may be from any type of computer printer.

The quality of this reproduction is dependent upon the quality of the copy submitted. Broken or indistinct print, colored or poor quality illustrations and photographs, print bleedthrough, substandard margins, and improper alignment can adversely affect reproduction.

In the unlikely event that the author did not send UMI a complete manuscript and there are missing pages, these will be noted. Also, if unauthorized copyright material had to be removed, a note will indicate the deletion.

Oversize materials (e.g., maps, drawings, charts) are reproduced by sectioning the original, beginning at the upper left-hand corner and continuing from left to right in equal sections with small overlaps.

Photographs included in the original manuscript have been reproduced xerographically in this copy. Higher quality 6" x 9" black and white photographic prints are available for any photographs or illustrations appearing in this copy for an additional charge. Contact UMI directly to order.

**ProQuest Information and Learning
300 North Zeeb Road, Ann Arbor, MI 48106-1346 USA
800-521-0600**

UMI[®]



Université d'Ottawa • University of Ottawa

An Antisymmetric, Minimalist Approach to Persian Phrase Structure

by:

Ahmad Moinzadeh

A Dissertation Submitted to
The Faculty of Graduate and Postdoctoral Studies
in Partial Fulfilment of the Requirements for
the Degree of
Doctor of Philosophy in Linguistics

April 2001

University of Ottawa

© **Ahmad Moinzadeh, Ottawa, Canada, 2001**



**National Library
of Canada**

**Acquisitions and
Bibliographic Services**

**395 Wellington Street
Ottawa ON K1A 0N4
Canada**

**Bibliothèque nationale
du Canada**

**Acquisitions et
services bibliographiques**

**395, rue Wellington
Ottawa ON K1A 0N4
Canada**

Your file Votre référence

Our file Notre référence

The author has granted a non-exclusive licence allowing the National Library of Canada to reproduce, loan, distribute or sell copies of this thesis in microform, paper or electronic formats.

The author retains ownership of the copyright in this thesis. Neither the thesis nor substantial extracts from it may be printed or otherwise reproduced without the author's permission.

L'auteur a accordé une licence non exclusive permettant à la Bibliothèque nationale du Canada de reproduire, prêter, distribuer ou vendre des copies de cette thèse sous la forme de microfiche/film, de reproduction sur papier ou sur format électronique.

L'auteur conserve la propriété du droit d'auteur qui protège cette thèse. Ni la thèse ni des extraits substantiels de celle-ci ne doivent être imprimés ou autrement reproduits sans son autorisation.

0-612-67975-6

Canada

Table of Contents

| | |
|---|-----|
| Abstract | III |
| Acknowledgements | IV |
| Abbreviations | VI |
| | |
| Chapter 1 Introduction | 1 |
| 1.1 Outline of the Thesis | 1 |
| 1.2 Theoretical Framework | 3 |
| 1.2.1 The Minimalist Program | 3 |
| 1.2.2 Linear Correspondence Axiom (LCA) | 6 |
| 1.2.3 Word Order Typology | 11 |
| 1.3 The Language under Investigation | 12 |
| 1.4 An Overview of Previous General Works on Persian Syntax | 13 |
| | |
| Chapter 2 The Ezafe Phrase: A Necessary Construction in the Study of All Non-Verbal Phrases | 23 |
| 2.1 Introducing the Construction | 23 |
| 2.2 A Review of Previous Works on the Ezafe Construction | 24 |
| 2.3 The Ezafe Phrase: A Proposal | 34 |
| | |
| Chapter 3 Persian Nominal Phrases | 46 |
| 3.1 Introduction | 46 |
| 3.2 The DP Hypothesis and Persian Nominal Constructions | 50 |
| 3.3 Is there any restriction to the elements preceding N*? | 57 |
| 3.4 The Order of Post-N* Modifiers: Complements | 69 |
| 3.5 Summary and Conclusions | 84 |
| | |
| Chapter 4 Persian Verb Phrases | 86 |
| 4.1 Introduction | 86 |
| 4.2 Review of Previous Works on Persian Sentence Word Order | 88 |
| 4.3 Summary of Literature Review on Persian Word Order | 99 |
| 4.4 On the Base Position of Object Relative to V* in Persian VPs | 101 |
| 4.4.1 Methodological Argument: Complement Selection of V* | 102 |
| 4.4.2 Empirical Arguments | 104 |
| 4.4.2.1 Parallel Use of SOV and SVO in Colloquial Persian | 104 |
| 4.4.2.2 Post-Verbal Position of CP Arguments as Evidence in favor of VO Word Order | 105 |
| 4.4.2.3 Placement of Clitics: Another Evidence in favor of a Head-Initial Analysis for VPs in Persian | 111 |
| 4.4.2.4 The Occurrence of Adverb between V* and its Complement | 118 |
| 4.5 Dative Constructions | 119 |
| 4.5.1 Introduction | 119 |
| 4.5.2 A Proposal for Persian Dative Constructions | 122 |
| 4.6 Summary and Conclusion of the Analysis of Persian VPs | 125 |

| | | |
|-------------------|---|-----|
| Chapter 5 | An Overview of Other Phrases (APs, PPs, IPs, CPs, TopPs) | 127 |
| 5.1 | Persian Adjective Phrases | 127 |
| 5.2 | Prepositional Phrases in Persian | 133 |
| 5.3 | Persian Sentences (IPs) | 137 |
| | Appendices: Left Periphery of the Clause (CP & TopP) | 151 |
| | Appendix 1: Persian CPs | 151 |
| | Appendix 2: Topicalization in Persian | 155 |
| | | |
| Chapter 6 | Diachronic Study of Persian Phrase Structure | 160 |
| 6.1 | Introduction | 160 |
| 6.2 | Old Persian | 161 |
| 6.2.1 | Noun Phrases in Old Persian | 161 |
| 6.2.2 | Old Persian APs | 164 |
| 6.2.3 | Old Persian PPs | 165 |
| 6.2.4 | VP in Old Persian | 167 |
| 6.2.5 | Old Persian Sentences | 169 |
| 6.2.6 | CP in Old Persian | 173 |
| 6.2.7 | Summary of the Analysis of Old Persian Phrasal Categories | 173 |
| 6.3 | Middle Persian | 174 |
| 6.3.1 | Middle Persian Nominal Phrases | 175 |
| 6.3.2 | AP in Middle Persian | 177 |
| 6.3.3 | PP in Middle Persian | 177 |
| 6.3.4 | VP in Middle Persian | 178 |
| 6.3.5 | Middle Persian Sentences | 179 |
| 6.3.6 | CP in Middle Persian | 182 |
| 6.3.7 | Summary & Conclusion of Middle Persian | 183 |
| 6.4 | Conclusion of Chapter 6 | 183 |
| | | |
| Chapter 7 | Summary and Conclusions | 186 |
| 7.1 | Summary | 186 |
| 7.2 | Conclusion | 190 |
| | | |
| References | | 191 |

Abstract

In this thesis, I investigate phrase structure in Persian within the Minimalist framework of Chomsky (1995, 1998). Adopting Kayne's (1994) Linear Correspondence Axiom, which examines the relation of hierarchical structure and linear order, I propose a head-initial analysis for Persian, and develop an analysis of SVO word order based on the examination of all lexical and functional categories.

Prior to investigating categories which are common to other languages, I examine the *Ezaf* Phrase (EzP), a functional phrasal category specific to Persian. The EzP is headed by a morpheme which may be phonetically realized as *e/ye* or null \emptyset . This morpheme regulates the occurrence of more than one complement in DPs/NPs and APs. Like the other phrasal categories investigated, the EzP is shown to follow the Spec-Head-Complement configuration (of the Linear Correspondence Axiom).

My argumentation for a head-initial configuration for Persian, and the implication of a basic SVO word order is based largely on evidence for noun phrases and verb phrases. I provide support for a DP analysis of Persian nominal phrases, and demonstrate that both DPs and lexical NPs display a head-initial configuration. While Persian VPs exhibit both VO and OV word order in unmarked sentences, I argue that they consistently display a head-initial configuration, an analysis which is theoretically preferable to one based on dual directionality. I support my proposal for a head-initial analysis of VPs and a basic SVO word order in Persian with a variety of empirical evidence about verbal complements, including the exclusive post-verbal generation of CP complements, the placement of clitics, and the position of adverbs relative to verbal heads and their complements.

While concentrating on DPs and VPs, I further support my analysis of a head-initial configuration for Persian by examining the Spec-Head-Complement configuration in APs, PPs, IPs and in less detail, the internal structure of CPs and TopPs. On the basis of both theoretical and empirical evidence, I propose a head-initial analysis for all phrasal categories in Persian. In conclusion, I turn to diachronic data which also provides evidence of the Spec-Head-Complement analysis I have proposed for Modern Persian.

Acknowledgements

Throughout my graduate studies, I enjoyed support from several sources. I would like to express my gratitude for the financial support I received from the Iranian Ministry of Science, Research and Technology (MSRT), which made my studies in Canada possible. I would also like to express appreciation for the additional financial support I received from the SSHRC Research Grant - 410-97-0242 of Prof. Maria-Luisa Rivero, and a Travel Grant from the Faculty of Graduate and Postdoctoral Studies.

I would also thank my supervisor, Prof. Maria-Luisa Rivero. It has been a great pleasure to work under her supervision. Her academic guidance has contributed greatly to the quality of this work. Her enthusiastic interest, combined with her understanding and patience, have been crucial factors in the completion of this work

During my studies at the University of Ottawa, I also benefited from the teaching and guidance of other professors, including André Lapierre, P.G. Patel, Philip Hauptman, Shana Poplack, Ian Mackay, Eta Schniederman, Konrad Koerner, Gerald Neufeld and John Jensen. I would also like to thank the administrative staff of the Department of Linguistics Yolande Theriault, Keemla Nuckchedee, Lise Picard, Sylvie Letang and Enrique Astroga for their assistance throughout my studies.

I would also like to express my gratitude to the members of my thesis committee, and to Juana Liceras who chaired my defense. The comments of Helen Goodluck, Paul Hirschbühler, Sima Paribakht, and Lisa Travis not only contributed to the quality of my work, but have also given me ideas for future research.

I would like to extend my sincere thanks to my fellow graduate students. I would especially thank Michele Foley for her friendship, and for her generous assistance in improving quality of my English. I would also like to express my appreciation to Shahla Raghibdoust, Reza Ghafarsamar, Mohammad Vahedi, Dawn Harvie, Louise Manga, Ejike Eze, Vera Roloff, James Walker, Laura Proctor, Abdul-Hamid Gadoua, Galina

Alexandrova, Anousha Sedighi, Elisabete Malvar, Danielle Turpin, Subhadra Ramachandran, Rodica Diaconescu, Olga Arnaudova, Seham Al-Ashhab, Carmen LeBlanc, Ian Wallace, Darrell Williams, Gerard Van Herk and Marjory Meechan.

Finally, I would like to express my deepest gratitude to my wife, Nikoo, for her love and overall support. Her patience and confidence in her "last minute man" made completion of this dissertation possible. Also, I thank my son, Arash, who played a prime role throughout this work.

Undoubtedly, no one deserves more appreciation than Nikoo, to whom I dedicate this thesis.

Abbreviations

| | |
|-----------------|--|
| A, Adj | Adjective |
| Acc | Accusative |
| Adv | Adverb |
| AdvP | Adverb Phrase |
| Agr | Agreement |
| Agrio | Indirect Object Agreement |
| AgrioP | Indirect Object Agreement Phrase |
| Agro | Object Agreement |
| AgroP | Object Agreement Phrase |
| Agrs | Subject Agreement |
| AgrsP | Subject Agreement Phrase |
| AP | Adjective Phrase |
| A-P | Articulatory-Perceptual |
| Aux | Auxiliary |
| C | Complementizer |
| Card | Cardinal Number |
| C _{HL} | Computational System of Human Language |
| C-H-S | Complement-Head-Specifier |
| C-I | Conceptual-Intentional |
| ClassP | Classifier Phrase |
| CL | Clitic |
| CLP | Clitic Phrase |
| CP | Complementizer Phrase |
| DAT | Dative |
| Dem | Demonstrative |
| DemP | Demonstrative Phrase |
| Det | Determiner |
| DO | Direct Object |
| DP | Determiner Phrase |
| EPP | Extended Projection Principle |
| EzP | Ezafe Phrase |
| FI | Full Interpretation |
| G-B | Government-Binding |
| Gen | Genitive |
| GT | Generalized Transformation |
| I, Infl | Inflection |
| IO | Indirect Object |
| IP | Inflectional Phrase |
| LCA | Linear Correspondence Axiom |
| LF | Logical Form |
| LIs | Lexical Items |
| LRC | Last Resort Condition |
| MLC | Minimal Link Condition |

| | |
|-----------------|--|
| N | Noun |
| Nom | Nominative |
| NP | Noun Phrase |
| NumP | Number Phrase |
| O, Obj | Object |
| OS | Object Shift |
| OSV | Object-Subject-Verb |
| OV | Object-Verb |
| P | Preposition |
| PF | Phonological Form |
| PL | Plural |
| PLP | Plural Phrase |
| PP | Prepositional Phrase |
| QP | Quantifier Phrase |
| S, Subj | Subject |
| SC | Structural Change |
| S-C-H | Specifier-Complement-Head |
| SDs | Structural Descriptions |
| S-H-C | Specifier-Head-Complement |
| Sing, Sg | Singular |
| SOV | Subject-Object-Verb |
| Spec | Specifier |
| SVO | Subject-Verb-Object |
| TEC | Transitive Expletive Construction |
| TopP | Topicalization Phrase |
| TP | Tense Phrase |
| UG | Universal Grammar |
| UTAH | Uniformity of Theta Assignment Hypothesis |
| V | Verb |
| VO | Verb-Object |
| VP | Verb Phrase |
| VSO | Verb-Subject-Object |
| XP | Maximal Projection of Type X |

Chapter 1

Introduction

This thesis explores phrase structure in Standard Colloquial Persian, a field which has been the subject of much ongoing research. My research is distinguished by its extensive investigation of phrasal categories in this colloquial register of Persian, and particularly by its concentration on the Specifier-Head-Complement relation. Working within a minimalist framework, the analyses I propose also follow an antisymmetric approach to syntax. Although essentially a synchronic study, I also present a diachronic survey of the phrasal categories discussed to provide a link with the earlier forms of Persian. In this introductory chapter, in 1.1, an outline of the thesis is presented. In 1.2, the theoretical foundations of this research are expressed. In 1.3, the language under investigation is introduced. And, in 1.4, an overview of previous general works on Persian syntax is presented.

1.1 Outline of the Thesis

In Chapter 1, the Introduction, I review the relevant literature and introduce some of the assumptions underlying the theoretical framework adopted in this research. Following this, I introduce Standard Colloquial Persian, the language under investigation, and provide an overview of some studies of Persian syntax.

In Chapter 2, the Ezafe Phrase (EzP) which is a construction specific to Persian is investigated. It is argued that the EzP, headed by the morpheme /e/ carries the characteristics of other maximal projections and regulates the relationship of the head of

NPs or APs with their complements. The repeatability of the EzP in those categories makes it possible for a head to have multiple complements. Following a review of previous works on this construction, a new analysis for the EzP is proposed.

Chapter 3 investigates nominal phrases, and the applicability of the DP Hypothesis to Persian is presented. Additionally, the phrasal categories which can occur in both specifier and complement positions are examined.

The verb phrase is the topic of investigation of Chapter 4. Given the VP-Internal Subject Hypothesis, in which both the subject and object are generated within the VP, any conclusions relative to the order of arguments within the VP effects assumptions about sentential word order. I present support for a VO order for subcategorized complements, and additionally examine Dative constructions.

Chapter 5 presents an overview of other phrasal categories, particularly APs and PPs. I also examine sentential structure and claim that the feature checking processes within the IP on the VP, combined with Move or Agree are responsible for different manifestations of word order allowed in this language. Additionally, I briefly survey the CP and TopP projections found in the left periphery of the clause.

Chapter 6 is devoted to a diachronic study of Persian phrase structure, which includes a brief history of the language. The occurrence of phrasal categories in both Old Persian and Middle Persian are examined.

Chapter 7 summarizes the findings of the thesis.

1.2 Theoretical Framework

This thesis adopts Chomsky's Minimalist Program and Kayne's Linear Correspondence Axiom, the most recent approaches in the Principles and Parameters Framework. Generative grammar, which emerged with Syntactic Structures (Chomsky 1957), transformed to the Standard Theory (Chomsky 1965), the Extended Standard Theory (Chomsky 1970, Jackendoff 1972) and the Revised Extended Theory (Chomsky 1973, 1977; Chomsky & Lasnik 1977; Chomsky 1980), until it changed to the Government and Binding Theory (Chomsky 1981, 1986a, 1986b) or more generally the Principles and Parameters approach. The latter approach, similar to any theory, has experienced some revisions. Its latest version which is called Minimalism, started in Chomsky (1991), and identified itself as the Minimalist Program in Chomsky (1993). This approach is elaborated in subsequent works (Chomsky 1994, 1995, 1998, 1999). The other theoretical basis of this research is the Antisymmetry of Syntax hypothesis proposed by Kayne (1994) in his Linear Correspondence Axiom (LCA). This dissertation juxtaposes the Minimalist Program and Kayne's Axiom, and applies them to the analysis of Persian phrase structure. In this section, these two founding theories are briefly introduced.

1.2.1 The Minimalist Program

Minimalism explicitly assumes that "the Principles and Parameters approach is in important aspects on the right track. Within any version of it, the major problem is to discover the principles and parameters and to show how a particular choice of parameter values and lexicon enters into fixing a language" (Chomsky 1998: p.4). According to Ouhalla (1999: p.403), "a minimalist theory of language is a theory which tries to minimize the theoretical machinery needed as much as possible". This is the spirit of minimalism which is followed

in recent years and which “seeks to discover to what extent minimal conditions of adequacy suffice to determine the nature of the right theory” (Chomsky 1998: p.5).

Starting with the central strongest minimalist thesis that human language is, in some general sense, a perfect computational system¹ and is an optimal solution to legibility conditions, the Minimalist Program seeks to eliminate D-Structure and S-Structure and limit the levels of syntactic representation to the two interface levels Logical Form (LF) and Phonological Form (PF). LF interfaces with Conceptual-Intentional (C-I) systems of cognition and PF is connected to Articulatory-Perceptual (A-P) modules. Each language determines a set of pairs drawn from the A-P and C-I levels, the former generally taken to be PF, while the status and character of the latter have been more controversial. Structural descriptions (SDs) must satisfy interface conditions at PF and LF, that is, these representations must satisfy the Principle of Full Interpretation (FI), well-formedness conditions such as Binding Theory, Control Theory, and Case Theory, among other conditions, and Economy conditions such as Minimal Link Condition (MLC).

In the Minimalist Program, language consists of a lexicon and a computational system. The lexicon specifies the items that enter into the computational system, along with their idiosyncratic properties. The computational system uses these elements to generate derivations and Structural Descriptions (SDs). The derivation of a particular linguistic expression, then, involves a choice of items from the lexicon and a computation that constructs the pair of interface representations. If the expression is legible at an interface

¹ To see the opposite on the optimality of language, see Johnson & Lappin (1999). Based on Head-Driven Phrase Structure Grammar (HPSG), they argue that there is no reason to believe that language is optimally designed, and conclude that the Minimalist Program is based on false assumptions, and fundamentally misguided.

level, its computation *converges* at that level; otherwise it *crashes* there. The computation *converges* if it converges at all interfaces. The *convergence* happens if an expression contains only features interpretable at an interface level, where interpretability denotes legibility to the external systems at the interface.

The selection of lexical items (LIs) from the lexicon and assembling them is done by an operation called *Generalized Transformation* (GT). This operation whose presence in generative grammar dates back to Chomsky (1957), in its original form performs a fairly complex operation which consists of more than one step. In the Minimalist approach, a simpler and modified version is adopted, whereby it has the function of selecting LIs from the lexicon, assigning them X-bar structures and then merging them together into larger phrase markers. That is to say, the operation GT is composed of the separate major operations *Select* and *Merge*. After the operation *Select* is completed, the operation *Merge* which is indispensable in some form of any language-like system, takes two syntactic objects (α , β) and forms $k(\alpha, \beta)$ from them. In addition to *Merge*, two other post-*Select* operations are involved in computational system of human language (C_{HL}): *Agree* and *Move*. *Agree* establishes a relation (agreement, case-checking) between a lexical item and a feature in some restricted search space (its *domain*). Unlike *Merge*, this operation is language-specific, never built into special-purpose symbolic systems and apparently without significant analogue elsewhere. *Move* is the combination of *Merge* and *Agree*, and is more complex than its subcomponents. Good design conditions would lead us to expect that simpler operations are preferred to more complex ones, so that *Merge* or *Agree* (or their combination) preempt *Move*, which is a “last resort”, chosen when nothing else is possible. While *Merge* “comes free”, any other operation requires justification.

The operations of the computational system (C_{HL}) that produce linguistic expressions must satisfy some general considerations of simplicity. These are referred to as “Economy Principles” in the Minimalist Program. Two of these principles which have survived and have been refined in the evolution of this program are the Last Resort Condition (LRC) and Minimal Link Condition (MLC). The Last Resort Condition prohibits superfluous steps in a derivation. It requires that every operation apply for a reason. The Minimal Link Condition (MLC) means that given the convergent derivations with the same number of steps, the one that involves shorter links is favored over the one that involves longer links. This principle imposes locality restrictions on the operation *Move*, by requiring that each movement be as short as possible. Any minimalist approach entails the consideration of the Economy Principles LRC and MLC in building up the convergent derivations.

The last principle in the Minimalist Program which is referred to here is the Principle of Full Interpretation (FI). Initially introduced in Chomsky (1986b), this principle requires that every element of an interface representation must provide a meaningful/legible input to the Articulatory-Perceptual (A-P) and Conceptual-Intentional (C-I) systems. Only these elements are considered to be legitimate objects in an interface level. The intuitive content of FI holds that an element can appear in a representation only if it is properly “licensed”.

1.2.2 Linear Correspondence Axiom (LCA)

In the minimalist version of the Principles and Parameters approach to the study of language, “the concepts of X-bar theory are fundamental. In the minimalist theory, the crucial properties and relations will be stated in the simple and elementary terms of X-bar theory” (Chomsky 1995: p.172). However, structures determined by X-bar theory do not establish a correlation between hierarchy and linear order which results in the association of

more than one order with a set of hierarchical relations. For example, postpositional phrases and prepositional phrases are generally taken to be hierarchically identical, differing only in linear order. This feature of X-bar theory makes the Head Parameter plausible. Kayne (1994) rules out the duality observed in this standard assumption and argues that hierarchical structure maps uniquely to linear order and proposes a restrictive theory of word order and phrase structure. He argues that phrase structure in fact always completely determines linear order and consequently that if two phrases differ in linear order, they must also differ in hierarchical structure. His antisymmetric approach to syntax is called the Linear Correspondence Axiom (LCA) which is pursued with minimalist goals in this research (as suggested by Chomsky 1998: p.5; footnote 13). Combining the Minimalist Program with the LCA stems from the fact that “the latter is very much in the spirit of the former” (Chomsky 1994: p.413). In the following section, I describe the LCA and briefly examine its consequences².

Starting from the familiar notion of phrase marker with the usual distinction between terminal symbols and nonterminal symbols, Kayne recalls that, at least in PF, the terminal symbols must be linearly ordered. A linear ordering has three defining properties. a) It is transitive; that is, $xLy \ \& \ yLz \ \rightarrow \ xLz$. b) It is total; that is, it must cover all the members of the set: for all distinct x, y either xLy or yLx . c) It is antisymmetric; that is, not $(xLy \ \& \ yLx)$. The familiar dominance relation on nonterminals is not a linear ordering. Although it is both transitive and antisymmetric, the dominance relation is not total; that is, there can be two nodes in a given phrase marker such that neither dominates the other.

² The antisymmetric approach to syntax has brought about satisfactory results in the study of other languages like Spanish (Ordóñez 1997) and Romanian (Stefanescu 1997).

The LCA presupposes a specific notion of c-command by adding antisymmetry to the relation of c-command as defined in (1):

(1) *Antisymmetric c-command*

X asymmetrically c-commands Y iff X c-commands Y and Y does not c-command X. This definition of c-command, combined with the relation between hierarchical and linear order paves the way for the LCA. To express the intuition that asymmetric c-command is closely matched to the linear order of terminals, let us, for a given phrase marker, consider the set A of ordered pairs $\langle X_j, Y_j \rangle$ such that for each j, X_j asymmetrically c-commands Y_j . Let us further take A to be the maximal such set; that is, A contains all pairs of nonterminals such that the first asymmetrically c-commands the second. This leads to Kayne's central proposal (for a given phrase marker P, with T the set of terminals and A as just given; d is the nonterminal-to-terminal dominance relations), the Linear Correspondence Axiom stated in (2):

(2) *Linear Correspondence Axiom*

$d(A)$ is a linear ordering of T.

In practice, the LCA works in the following way:

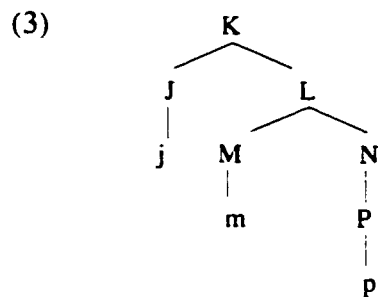

In (3), the set A of pairs of nonterminals contains the ordered pairs $\langle J, M \rangle, \langle J, P \rangle, \langle M, P \rangle$. $d(A)$ is the set $\langle j, m \rangle, \langle j, p \rangle, \langle m, p \rangle$. These three ordered pairs constitute a *linear ordering* of the set

of terminals {j,m,p}, given that (a) transitivity holds, (b) antisymmetry is respected, and (c) the ordering is total, i.e. an ordering is specified for every pair of terminals. Note that Kayne crucially takes c-command to be properly defined in terms of “first node up” and not in terms of “first branching node up”. Under the latter type of definition, the node P in (3) would c-command M, so that M would no longer asymmetrically c-command P, in which case no ordering between the terminals m and p would be specified at all, incorrectly

. From the perspective of the LCA, linear order turns out to be more fundamental to syntax than is normally thought. As a result of the LCA, the property of antisymmetry that a linear ordering has is inherited by the hierarchical structure. Kayne argues that this is behind X-bar theory, or rather, that X-bar theory, although largely accurate in its standard form, should not be considered to be a primitive part of UG. What is primitive in UG is the LCA, from which follow familiar X-bar-theoretic properties listed in (4):

- (4) a. The need for a phrase to have a head.
- b. The impossibility for a phrase to have more than one head.
- c. The limitation to one specifier per phrase.
- d. The limitation to one sister complement per head.
- e. The requirement that a complement not be a bare head.

In addition to the five X-bar-theoretical properties deduced from the LCA, the following are the other consequences of adopting an antisymmetric approach to syntax:

- 1. The LCA limits phrase structure diversity, in that it limits adjunctions to one per phrase or head adjoined to. In the case of adjunctions of phrases, that amounts to saying that there is no distinction between adjunctions and specifiers.

2. Extending the LCA-based theory to subword structure leads to the proposal that clitics must adjoin to empty heads rather than to (finite) verbs.
3. Specifier-Head-Complement order is the only order made available by UG and consequently there can be no directionality parameter for word order.
4. No rightward adjunction movement rules are permitted.
5. No right-adjunctions are permitted in the base.
6. There is never a choice available between multiple left-adjunctions and multiple heads each with one specifier.
7. No right-hand specifier positions are available.
8. No left-hand complement positions are available.

Although the foregoing conclusions of the antisymmetry of syntax are interdependent, the general Spec-Head-Complement order derived from the LCA-based theory of syntax stands out³. This result dispenses with the directionality parameter for word order and opens a new horizon for the study of word order typology. To see the importance of this field in generative grammar, in 1.2.3, a summary of the background of word order typology is presented.

³ Murvat Kural (1997) argues against the LCA using data from Turkish. He suggests that Turkish is really head-final. He says, "unlike Dutch and German, Turkish is exclusively postpositional, allows no postnominal complements inside noun phrases, and places auxiliaries and inflected verbs on the right" (Kural 1997: p.499). He suggests that "there are enough clues for children learning Dutch and German to posit a head-initial structure: Both languages are predominantly prepositional; they have postnominal complements inside noun phrases; and inflected verbs appear on the left because of the verb second phenomenon." Then, he concludes, "none of these is a factor in Turkish, so children learning the language have no empirical reason to assume a head-initial structure" (Ibid. p.518).

1.2.3 Word Order Typology

In his study of word order, Greenberg (1963) sets up a typology involving certain basic factors of word order, and refers to this typology as the basic order typology. In doing so, he employs three criteria: 1) the existence of prepositions as opposed to postpositions, 2) the relative order of Subject, Verb and Object in declarative sentences with a nominal subject and object, and 3) the position of qualifying adjectives in relation to nouns. On the basis of data from 30 languages, Greenberg proposes 45 universals of grammar. The aim of recalling Greenberg's work and subsequent approaches to the study of language universals is to highlight the importance of this field in the development of linguistic theory and the simplified universal S-H-C proposed by Kayne's LCA. Crucial to the 3 sets of criteria proposed by Greenberg is the notion of "head". The first criterion seeks the position of P' in PPs relative to its complement; the second one seeks the position of V' relative to its Spec, i.e. Subj, and to its complement, i.e. Obj, in VPs and IPs; and the third criterion is looking for the position of attributive adjectives in NPs relative to the head N'. In addition to the "Head Parameter". Greenberg distinguishes between the *dominant* word order and the *more frequent* one. To him, the notion dominance refers to the unmarked, and stylistically neutral order of constituents in a sentence. Both of the notions *head* and *dominant* versus *more frequent order* play a great role in the analyses of this research.

Vennemann (1972) attempts to reformulate and explain Greenberg's universals. While Greenberg argues in favor of a three-way typology of VSO, SVO and SOV as the only normally occurring dominant orders, Vennemann reduces them to basic verb positions. Therefore, Greenberg's type I, II and III languages reduce to two major language types- VO languages and OV languages. Vennemann's reformulation is based on Lehmann (1971).

The new configuration given to the word order typology is elaborated in subsequent works such as Hawkins (1983). Kayne's LCA indicates a turning point in word order typology in that it rules out the Head Parameter and proposes that the Spec-Head-Complement structure is a part of UG. Recall that Greenberg suggested three possible word orders for languages: VSO, SVO and SOV. This typology later transformed to OV and VO languages by Vennemann. While emphasizing the importance of the position of the complement relative to its head, i.e. the relation between Obj and V', Kayne claims that the only possible order is the order in which the head precedes its complement. The other factor which Kayne considers is the role of specifiers. He suggests that consideration of the relative order of head and complement alone is not sufficient to yield any firm conclusion, since both head-complement and complement-head orders are widely attested (Kayne 1994: p.35). Therefore, he proposes the specifier be added to any formulation of word order, the result of which will be either Spec-Head-Complement or Complement-Head-Spec. Of these two orders, he suggests that S-H-C is a significantly more plausible universal than is C-H-S. Hence, he arrives at the point that SOV (and more generally S-C-H) is strictly impossible in any language, if taken to indicate any phrase marker in which the sister phrase to the head (i.e. the complement position) precedes the head. His final conclusion is that the only possible constituent order is SVO or more generally Spec-Head-Complement.

1.3 The Language under Investigation

The language under investigation in this thesis is Standard Colloquial Persian, which is basically the Tehrani dialect spoken by educated people in the capital city of Iran. Contemporary Persian is characterized by a large number of different dialects spoken and

spread throughout the country, e.g. Tehrāni, Esfahāni, Mashhadi, Shirāzi, Kermāni and so on, as well as the dialects used in Afghanistan and Tajikistan. Basically, the distinguishing feature of the main Persian dialects of Iran is their phonetic representations. This feature is so marked that it is possible to recognize the hometown and even sometimes the neighborhood of a native speaker just by listening to him. Despite this diversity in pronunciation, the different dialects exhibit relatively few syntactic and morphological differences. This similarity along with the official status of the Tehrani dialect has contributed to its acceptance as the Standard Colloquial language of Iran. Standard Colloquial Persian is the language spoken in the media, in Iranian educational centers and governmental offices, and also among Iranian immigrants abroad. The choice of colloquial Persian as the language of study for this thesis also reflects the priority of spoken language over its written form in linguistic studies, and the belief that this register illustrates the true nature of language more naturally.

1.4 An Overview of Previous General Works on Persian Syntax

Various aspects of Persian syntax have been studied both by traditional grammarians and modern linguists. The studies highlighted below have made important contributions to our knowledge of this language.

Moyne (1970) analyzes the structure of verbal constructions. This work is considered to be the first attempt to analyze the syntactic structure of the Persian verb phrase in the framework of Chomsky's Standard Theory in *Aspects* (1965). Moyne's main contribution in the study of the verb phrase is his transformational analysis of compound verbs in Persian in which he suggests the following deep structure:

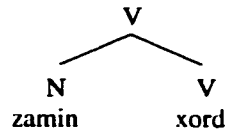
- (5) a. 
- b. hušang saxt zamin xord
hard ground hit
 "Hushang fell down hard."

Proposing the representation (5a) for compound verbs, he concludes that the nominal element of a compound verb is not an independent NP and, consequently, it cannot take the postposition *rā*, it cannot pluralize nor pronominalize, and it cannot be independently modified.

Marashi (1970) studies the Persian verb in the context of teaching Persian to speakers of English. He concentrates on the syntactic properties rather than morphological features of the verb. His approach is basically within the framework of Chomsky (1965). After giving an outline of Persian syntax and presenting the syntactic relationship of the verb to other major categories, he deals with the syntactic features of the verb, including its place in the sentence. An analysis of modals and auxiliaries, and a discussion of their similarities and differences are the other subjects discussed in this work. As discussed in Chapter 4, Marashi concludes that Persian is underlyingly an SVO language, a conclusion which makes him the sole supporter of a head-initial analysis of the Persian verb phrase.

Tabaian (1974) is concerned with the description of compound sentences, relative clauses, and complement clauses within a generative-transformational grammar. This description involves: (a) the presentation of surface structures of these constructions by means of a selected set of data; (b) the determination of their deep structures on the basis of the data; and (c) the postulation of the transformations necessary to relate the deep structures

to surface structures. Tabaiian suggests that his work demonstrates the descriptive adequacy of the generative- transformational grammar in handling data from diverse languages.

Soheili-Isfahani (1976) presents a syntactic as well as a semantic analysis of some major aspects of NP complementation from a transformational viewpoint. He argues that all NP complements in Persian occur to the right of their head noun which gives a head-initial status to all NPs. As for word order, he postulates a dominant SOV order, but suggests that this order may be scrambled for focus or topicalization, yielding OSV and VSO orders. To justify post-verbal placement of Obj when it is a CP, he postulates an extraposition transformation which moves an embedded complement clause from its pre-verbal position to the right of the matrix predicate.

Hajati (1977) studies complement and relative constructions and their function. These constructions are called *ke*-constructions, because they begin with the complementizer *ke* "that". Hajati studies these constructions within the theoretical framework of Chomsky (1965), and concludes that both complementation and relativization constructions share almost identical properties. These two constructions are shown in (6):

(6) a. Complementation

man [in rā [ke ali bargašte]] aslan ne-mi-dānest-am
I this rā that Ali returned at all not - know - I
"I did not know at all that Ali has come back."

b. Relativization

man [ketābi rā [ke xaride bud-am]] gom kard-am
I book rā that bought was-I lost did - I
"I lost the book that I had bought."

Farrokhpey (1979) studies the syntax and semantics of auxiliaries and modals, and argues that they are dominated by the node VP, and that they differ from other main verbs

only in their base forms. The lexical configurations he proposes for Persian modals and auxiliaries are illustrated in (7):

| | |
|--|--|
| (7) Modals and Main Verbs | Auxiliaries |
| $\begin{bmatrix} +V \\ -Aux \end{bmatrix}$ | $\begin{bmatrix} +V \\ +Aux \end{bmatrix}$ |
| tavānestan "can" | budan "be" |

The theoretical framework for the syntactic analysis of these two categories is the Higher Verb Analysis which states that auxiliaries and modals are derived from the main verbs of higher clauses. In spite of Marashi's contribution to the study of modals and auxiliaries mentioned above, Farrokhpey emphasizes several times that his dissertation is the first study of these two categories from a generative-transformational point of view (demonstrating his unawareness of Marashi 1970).

Aghbar (1981) studies Persian verbs within the framework of Cook's (1979) Case grammar. He argues that the case roles are among the most basic concepts universally shared by speakers of all languages but that the case frames are language specific although certain favorite verb types seem to emerge across languages.

Dabir-Moghaddam (1982) studies the syntax and semantics of causative constructions. The general theoretical framework adopted in this study is the version of the Standard Theory (Chomsky 1965), explained in Akmajian & Heny (1975). This study shows that the class of morphological (and auxiliary) causatives is only a part of the system of causation in Persian. The general major goals of this research are (1) to introduce various categories of causation in Persian, and (2) to put them into proper perspective.

Barjasteh (1983) deals with morphology, syntax and semantics of Persian compound verbs from a lexicalist viewpoint. Compound verbs are composed of a pre-verbal element, which may be nominal, adjectival, adverbial, verbal, or prepositional, plus a main verb as illustrated in (8):

- (8) a. Nominal: *ejāze* *dādan*
 allowance *give*
 “allow”
- b. Adjectival: *kam šodan*
 less *become*
 “lessen”
- c. Adverbial: *pas* *dādan*
 again *give*
 “give back”
- d. Verbal: *dād -o- setad* *kardan*
 give and receive *do*
 “trade”
- e. Prepositional: *bar dāštan*
 up *have*
 “pick up”

Functioning within the framework of the Lexicalist Hypothesis (conceived originally by Chomsky 1970), he proposes a model of the lexicon for Persian that consists of three major subcomponents, that is, Lexical Core, Lexical Rules of Word Formation, and Stress Assignment.

Samiian (1983) provides an analysis of the phrase structure rules of non-verbal phrasal categories within the framework of the Extended Standard Theory and in particular X-bar syntax. This study is a syntactic analysis of the base rules for NPs, but also includes a cursory look at the base structures for APs and PPs. The addition of the analyses of these two categories is due to the role that the Ezafe Phrase plays in all of these three phrasal categories. Samiian is the first modern linguist who bases her study on Standard Colloquial Persian rather than the formal written form. Her main contribution to the study of Persian syntax is her treatment of the Ezafe Phrase that I discuss in Chapter 2.

Karimi (1989) studies the interaction of syntactic principles with specificity and implications of this interaction for the theory of universal grammar. Karimi's original purpose of writing her dissertation was to provide a syntactic analysis of the word order and the internal structure of Persian VPs. However, in the process of her research, she was confronted with the problematic function of the postpositional morpheme *rā* which led to a comprehensive study of this well known "definite direct object marker". She concluded that *rā* was the "specific oblique morpheme", a new interpretation for this morpheme. Also, she was the first linguist who adopted the DP Hypothesis for the analysis of Persian nominal phrases. As to the implications of the phenomena discussed in her thesis with the theory of UG, she concludes that discourse conditions as well as language specific parameters are subordinated to general principles of universal grammar.

Hashemipour (1989) investigates the binding effects of pronominals and controlled elements within the GB framework. In her work, Hashemipour examines two types of parametric variation in the binding effects of Colloquial Persian. In the first, she shows that defining different binding domains alone is not sufficient to account for the distribution of pronominals. Distinct structural relations between the pronominal and its potential antecedents must also be posited. The second topic involves accounting for the obligatory coreference between a controlled empty subject that is embedded in a clause with finite inflection and a matrix NP. In this work, the Binding Principles are revised, using the notions C-free (not linked to c-command NPs) and C'-free (not linked to non-c-commanding NPs).

Darzi (1995) investigates word order, NP-movement, and opacity conditions within the GB framework. Concentrating on Raising Constructions, he discusses the underlying

word order of Persian for the purpose of investigating the nature of scrambling in simplex clauses. He demonstrates that the subject in Persian must precede and c-command the object in order to argue that in putative instances of object-to-subject raising in non-passive constructions the raised object does not land in the subject position of the raising predicate in accordance with the Relativized Minimality Condition. Also, he investigates a class of raising constructions treated in previous works as involving either A/A'-movement or Control.

Ghomeshi (1996) studies phrase structure based on the following four assumptions. a) Monosemy, i.e. uniting the various occurrences of morphemes that are identical to their phonological properties, is desirable in grammar. b) Only inflectional affixes and not derivational affixes can correspond to syntactic projections. c) Projection is driven by the features borne by lexical and functional categories. d) Base-generated X'-adjunction is possible in the syntax. In her dissertation and her later work, Ghomeshi examines the Ezafe Construction, the postpositional morpheme *rā*, clitics and the structure of DP.

Vahedi (1996) studies the argument structure and formation of the very productive and frequent complex verbal structures known as compound verbs or complex predicates. As mentioned earlier in the review of Barjasteh (1983), Persian complex predicates are made up of a preverbal element and a verb. Preverbal elements may belong to any of the lexical categories N, Adj, Adv, or P. Verbal elements are light verbs like *kardan* "do". Observing a major dichotomy in the syntactic and lexical function of complex predicates, Vahedi proposes two isomorphic levels of syntactic structure in the format of X-bar theory in the lexical and syntactic components. He argues that both full verbs and their equivalent light verbs share the isomorphic syntactic structure. Both types belong to the universal

category verbs which take a single complement in the lexical and syntactic domains (Larson 1988 and Hale & Keyser 1991, 1993). Word formation takes place in the morphological and/or the lexical component but not in the syntactic one which accounts for the dual behavior of the complex predicates in these two levels. His theoretic framework in the lexical domain is the theory of Lexical Relational Structure proposed by Hale & Keyser (1991, 1993).

Miremadi (1997) is basically an adaptation of Cowper (1992) which presents a GB-based analysis of different aspects of Persian syntax.

The research on Persian syntax extends far beyond the above-mentioned works. However, there are two distinguished works in modern linguistics which comprehensively investigate Persian phrase structure, the topic of research I am pursuing here. The first of these, Bateni (1969), surveys Persian grammar based on the theory of Categories, or as it is known in England the theory of Scale and Category proposed by Halliday (1961). This linguistic theory considers four categories and three scales for grammar. The categories are: unit, structure, class and system. The scales are: scale of rank, scale of exponence and scale of delicacy. Bateni, a Neo-Firthian, presents the basic paradigms of the Persian sentence, clause, phrase and word. This research is known to be the first structural, descriptive grammar of Persian. While it exhibits some of the tendencies of the Structuralist School, the importance of this comprehensive study of the grammatical structure of Persian remains recognized today.

The second study, that of Meshkat al-Dini (1987) analyzes Persian syntax within the framework of Chomsky (1965) and later refinements of this theory. This research, like that of Bateni (1969), surveys all Persian phrasal categories. Given that this transformational,

generative analysis occurred before the Government and Binding era, it differs not only from the research by Bateni (1969), but also from the research I am presenting here. However, along with Bateni (1969) and Meshkat al-Dini (1987) I share a common topic of research, namely, the variant manifestations of Persian phrase structure.

The position of phrasal elements in relation to the phrasal head is a recurring topic in Persian syntax. In spite of following different theories and linguistic schools, there is a consensus among linguists regarding the position of the head in all Persian phrases except verb phrases. The general agreement suggests that in all phrases other than VPs, the head selects its complement to the right (Karimi 1999: p.126; Ghomeshi 1996: p.49; Meshkat al-Dini 1998: p.13; Mahootian 1993: p.61), as illustrated in (9):

- (9) a. NP [NP *pesar-e xub*]
 boy Ez good
 “the good boy”
-
- ```

graph TD
 NP1[NP] --- N_prime[N']
 NP1 --- Complement1[Complement]
 N_prime --- pesar[pesar]
 Complement1 --- e_xub["e xub"]

```
- b. AP            u [AP *sifte-ye elm*] *ast*  
                           *he fond Ez science is*  
                           “He is fond of science.”
- 
- ```

graph TD
    AP1[AP] --- A_prime[A']
    AP1 --- Complement2[Complement]
    A_prime --- sifte[sifte]
    Complement2 --- ye_elm["ye elm"]
  
```
- c. PP [PP *ruye miz*]
 on table
 “on the table”
-
- ```

graph TD
 PP1[PP] --- P_prime[P']
 PP1 --- Complement3[Complement]
 P_prime --- ruye[ruye]
 Complement3 --- miz[miz]

```

The position of the head in VPs remains controversial. Traditional grammarians prescribe an SOV order for Persian which puts the complement of the V' to its left. As a matter of fact, this order is dominant in the written form of Persian. But instances of the complements

appearing to the right of V' especially in Colloquial Persian have encouraged many modern linguists to consider the head-initial possibilities as well (Meshkat al-Dini 1998: p.13; Jazayery & Paper 1961; Marashi 1970; Soheili-Isfahani 1976; Comrie 1981; Kruse 1978; Karimi 1989). The two possible orders of V' and its complement are illustrated in (10):

- |      |                         |                         |
|------|-------------------------|-------------------------|
| (10) | a. OV                   | b. VO                   |
|      | man ketāb-ro xund-am    | man xund-am ketāb-ro    |
|      | <i>I book rā read-I</i> | <i>I read-I book rā</i> |
|      | "I read the book."      | "I read the book."      |

Clearly, in (10a), V' selects its complement to the left; but in (10b), the complement appears to the right of V'. This important aspect of Persian syntax will be extensively dealt in our survey of Persian VPs, where I argue in favor of a head-initial status for Persian VPs. This results in a consistent analysis of the head-complement order in all grammatical categories.

Before starting our investigation of Persian phrases, in Chapter 2, a construction that plays a significant role in the syntax of this language will be surveyed and a new analysis which is compatible with the theoretical foundations of this research will be proposed. This construction is traditionally called the Ezafe Construction, which I will call the Ezafe Phrase or EzP.

## Chapter 2

### The Ezafe Phrase:

### A Necessary Construction in the Study of All Non-Verbal Phrases

#### 2.1 Introducing the Construction

One of the peculiar features of Persian syntax which has a significant role in the phrase structure of this language is what has been traditionally called the “Ezafe Construction”. The term *Ezafe* literally means “addition”, and refers to the unstressed morpheme /e/<sup>1</sup> which appears between the head of a phrase and certain modifiers and complements following the head. The Ezafe construction occurs in noun phrases and adjective phrases, as shown in (1):

- (1) a. in    pesar-e    bāhuš  
      *this boy Ez clever*  
      “this clever boy”
- b. farār-e    bozorg  
      *escape Ez great*  
      “the great escape”

---

<sup>1</sup> . The morpheme for Ezafe is /e/, but if the word ends in a vowel, /ye/ is used instead of /e/, as the following examples show:

- a. nāme-ye    ali  
      *letter Ez Ali*  
      “Ali’s letter”
- b. pāru- ye    čubi  
      *paddle Ez wooden*  
      “the wooden paddle”
- c. zibā - ye    xofte  
      *beauty Ez sleeping*  
      “sleeping beauty”

- c. *alāqemand-e musiqi*  
*interested Ez music*  
 “interested in music”
- d. *violonzan-e ruye bām*  
*fiddler Ez on roof*  
 “Fiddler on the roof”
- e. *dānešju- ye alāqemand-e zabānšenāsi*  
*student Ez interested Ez linguistics*  
 “the student interested in linguistics”

In (1a), the Ezafe construction *e bāhuš* “Ez clever”, which is comprised of “Ez + A”, is the complement of the DP *in pesar* “this boy”. In (1b), the Ezafe construction *e bozorg* “Ez great”, which again is “Ez + A”, is the complement of the N’ *farār* “escape”. In (1c), the Ezafe construction *e musiqi* “Ez music”, which is “Ez + N” is the complement of the A’ *alāqemand* “interested”. In (1d), the Ezafe construction *e ruye bām* “Ez on roof”, which is “Ez + PP”, is the complement of the N’ *violonzan* “fiddler”. And in (1e), two Ezafe constructions are used: first, *ye alāqemand-e zabānšenāsi* “Ez interested Ez linguistics”, which is “Ez + AP” is the complement of the N’ *dānešju* “student”, and second, *e zabānšenāsi* “Ez linguistics”, which is “Ez + NP”, is the complement of the NP *dānešju-ye alāqemand* “student Ez interested”. Before presenting my analysis of this structure, I will clarify certain aspects of this construction through reference to previous studies.

## 2.2 A Review of Previous Works on the Ezāfe Construction

Previous studies have normally surveyed the Ezafe construction in terms of the semantic relation expressed by the construction. Tabaian (1974) suggests that although the Ezafe has received a great deal of attention in almost all grammars on Persian, these treatments usually do not go beyond a classification of Ezafe constructions into several types. In the majority of

the available classifications, the reader is usually provided with a description of the constituents of the Ezafe coupled with some remarks about the semantic contents of the constituents. To illustrate this idea, he examines the three best known classifications of Ezafe constructions. The first classification, which is Bahār et al. (1938), is an exclusively semantic study of the Ezafe construction, and recognizes five types of Ezafe constructions as basic, and lists them as shown in (2):

(2) a) Ezafe of Qualification

angoštar-e talā  
*ring Ez gold*  
"the gold ring"

b) Ezafe of Possession

ketāb-e hasan  
*book Ez Hassan*  
"Hassan's book"

c) Ezafe of Allocation

dar-e xāne  
*door Ez house*  
"the door of the house"

d) Ezafe of Similarity with two types:

a. lab-e la:l  
*lip Ez ruby*  
"ruby lip"

b. la:l-e lab  
*ruby Ez lip*  
"the ruby of the lip"

e) Metaphoric Ezafe

dast-e ruzegār  
*hand Ez time*  
"the hand of time"

Bahār et al.'s description of the Ezafe construction is the basis of other surveys of this construction in the works of grammarians.

The second classification of the Ezafe construction is Hodayun-Farrokh (1958) which using both semantic and morphological criteria recognizes six basic Ezafe types. Hodayun-Farrokh accepts the metaphoric Ezafe and the Ezafe of similarity of Bahār et al. (1938), but does not consider the Ezafe of allocation distinct from the Ezafe of possession. His main achievement in the classification of Ezafe constructions is the split of the Ezafe of qualification into Ezafe of qualification and Ezafe of modification. Later, he divides the Ezafe of qualification into stative and complementary Ezafe as (3) displays:

(3) Ezafe of Modification

barg-e sabz  
*leaf Ez green*  
"green leaf"

Ezafe of Qualification (Stative)

tir-e āhan  
*beam Ez iron*  
"iron beam"

Ezafe of Qualification (Complementary)

ruz-e šanbe  
*day Ez Saturday*  
"the day which is Saturday"

The final classification of Ezafe constructions is Lazard (1957) which is based on morphologically defined categories, and divides the Ezafe construction into five major types. Based on the semantic features of the constituents of Ezafe constructions, these major types are further divided into one or more sub-types classifying ten sub-types altogether, as illustrated in (4):

(4) a. Ezafe of Modification

āb - e garm  
*water Ez hot*  
"hot water"

b. Ezafe of Location

javān - hā - ye emruz  
*youth - PL Ez today*  
"modern youth"

c. Ezafe of Qualification (with five subtypes):

i. origin

āb-e çeşme  
*water Ez spring*  
"spring water"

ii. material or substance

tāj-e zar  
*crown Ez gold*  
"the gold crown"

iii. appropriateness

āb-e xordan  
*water Ez drink*  
"drinking water"

iv. product

āb-e hayāt  
*water Ez life*  
"water of [eternal]life"

v. metaphoric

lab-e la:l  
*lip-Ez ruby*  
"ruby lip"

d. Ezafe of Possession (with 5 subtypes)

i. ownership

xāne-ye hasan  
*house Ez Hassan*  
"Hassan's house"

ii. source

āb-e çešme  
*water Ez spring*  
"the water of the spring"

iii. objective

pul-e nāhār  
*money Ez lunch*  
"the money for the lunch"

iv. partitive

dar-e xāne  
*door Ez house*  
"the door of the house"

v. locative

taraf-e tehrān  
*side Ez Tehran*  
"in the direction of Tehran"

e. Ezafe of Specification

šahr-e tehrān  
*city Ez Tehran*  
"the city of Tehran"

Clearly, all of the classifications mentioned above provide the reader with a description of the constituents of the Ezafe construction along with a notion of the semantic contents of the constituents.

In the generative literature on Persian syntax, Tabaian (1974) is the first linguist who tries to give a new analysis for this construction based on Chomsky (1965). He considers the Ezafe construction as a contracted form of an independent clause which is transformed into a phrase through a syntactic process. In other words, this construction results from a series of transformations (addition, substitution, deletion) applied to the structures like (5a), yielding (5b):

- (5) a. man ketāb-i xarid-am va ketāb sabz bud.  
*I book-a bought-I and book green was*  
 "I bought a book, and the book was green."
- b. ketāb-e sabz-i xarid-am  
*book Ez green-indefinite bought-I*  
 "I bought a green book."

To derive (5b) out of (5a), Tabaian utilizes the following consecutive transformations to produce the resulting construction. These transformations and their step-by-step outcome are shown in (6):

| (6) <u>Transformation</u>     | ⇒ | <u>Phasic Result</u>                                                                       |
|-------------------------------|---|--------------------------------------------------------------------------------------------|
| I. "ke" insertion             | ⇒ | man ketāb-i xaridam va ke ketāb sabz bud<br><i>I book-a bought and that book green was</i> |
| II. "va" deletion             | ⇒ | man ketāb-i xaridam ke ketāb sabz bud                                                      |
| III. pronominalization        | ⇒ | man ketāb-i xaridam ke un sabz bud<br><i>it</i>                                            |
| IV. pronoun deletion          | ⇒ | man ketābi xaridam ke sabz bud                                                             |
| V. copula deletion            | ⇒ | man ketābi xaridam ke sabz                                                                 |
| VI. "ke" deletion             | ⇒ | man ketābi xaridam sabz                                                                    |
| VII. ezafe insertion          | ⇒ | man ketāb sabz-i xaridam                                                                   |
| VIII. ezafe particle addition | ⇒ | man ketāb-e sabzi xaridam<br><i>Ez</i>                                                     |

Although Tabaian's analysis is a novelty in the field and proposes a purely syntactic account for the structure under investigation, it is not compatible with the recent views in generative syntax and especially the theoretical foundations of this research.

Samiian (1983) is the next generative linguist who studies the Ezafe construction within the framework of the Extended Standard Theory and in particular X-bar theory. The core idea of Samiian is that in the Ezafe construction, the Ezafe morpheme /e/ is transformationally inserted before each phrasal complement. As a matter of fact, the idea of Ezafe insertion is not a new idea, since Tabaian (1974) introduces this transformation for the analysis of the Ezafe construction. It seems that Samiian, at the time of writing her dissertation, was not aware of Tabaian (1974), because there is no reference to that work in her thesis. In any case, she gives the following rule to account for the presence of the Ezafe vowel:

(7) Ezafe Insertion Rule

$$X^{\max} \longrightarrow e + I \text{ when } X^{\max} \text{ is immediately dominated by } Y', X \& Y \neq V$$

This rule inserts the Ezafe vowel before every non-verbal phrasal category that occurs below the  $X'$  level. To see how Samiian's Ezafe Insertion Rule works, we apply this rule to the case where  $X^{\max}$  is an NP. She proposes the following structure as the base configuration for  $\tilde{N}$ , with all the Ezafe-bearing complements generated as right sisters of the head:

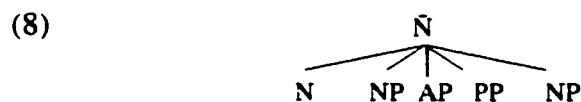

The outcome of applying the Ezafe Insertion Rule to her NP-configuration would mean that the vowel *e* will occur before each of the phrasal constituents under  $\tilde{N}$ .

In what is essentially a sociolinguistic study, Mahootian (1993) introduces a new theoretical analysis of the Ezafe construction, suggesting for the first time that it is a phrase, and proposes the Ezafe Phrase, which has the Ezafe morpheme as its head. Working within the G-B framework, Mahootian, unlike Samiian, does not use any transformational rules. She gives a small clause analysis to Ezafe Phrase and proposes the structural analysis shown in (9):

(9) a. *ketāb-e ali*  
*book Ez Ali*  
 "Ali's book"

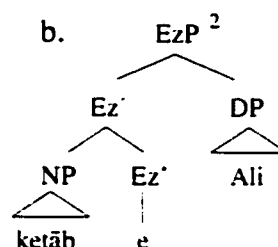

As shown in (9), Mahootian proposes that  $Ez^{\circ}$  is a functional element and the head of its construction, with the DP *Ali* as the specifier of the  $EzP$ . Apparently, the sister to  $Ez^{\circ}$  should be its complement which gives the NP *ketāb* "book" this status in the structure of this phrase. This analysis of the  $EzP$  assumes a head-final configuration for this construction. Although I agree with Mahootian that the Ezafe Construction represents a phrasal category, I suggest that Mahootian's analysis of the  $EzP$  should be revised based on the LCA assumptions. I thus propose a head-initial phrasal category for the  $EzP$  whose head is the morpheme *e* with its complement to the right and its specifier to the left. Based on this analysis which will be elaborated in Chapter 3, and following the DP Hypothesis adopted in this research, (10a) will have the tree in (10b), in which the null  $D^{\circ}$ , head of the DP, selects an  $EzP$  as its complement to the right. The complement of this  $EzP$  is an AP. Then, another

<sup>2</sup> I have made some refinements to her symbols to make them compatible with the symbols used in this research. Needless to say, these refinements do not change her line of argumentation.

EzP will be selected as the complement of this AP. The complement of the second EzP is a PP. Then, this PP will select an NP as its complement. Later, this NP selects the lowest EzP as its complement. In the last stage, another NP will be chosen as the complement of the lowest EzP. The N° *otāq* “room” originates in the Spec of the lowest EzP which makes its semantic relation with the lowest NP “Ali” possible. This N° moves higher up, not as a head but as an XP, and, bypassing Spec NP and Spec PP which are potentially filled with relevant XPs, lands in the Spec of the intermediate EzP where it fulfils the semantic relation of *otāq* “room” with the PP *zir-e širvāni-e Ali*. In the last stage, the maximal projection NP containing the N° *otāq* “room” moves higher up and lands in the Spec of the highest EzP and will be realized as the N° *otāq* “room”, which raises to D° yielding the PF realization of the DP. The foregoing process is illustrated in (10):

- (10) a. *otāq-e kučik-e zir-e širvāni-e ali*  
*room Ez small Ez under Ez roof Ez Ali*  
 “Ali’s small room under the roof”

(10) b.

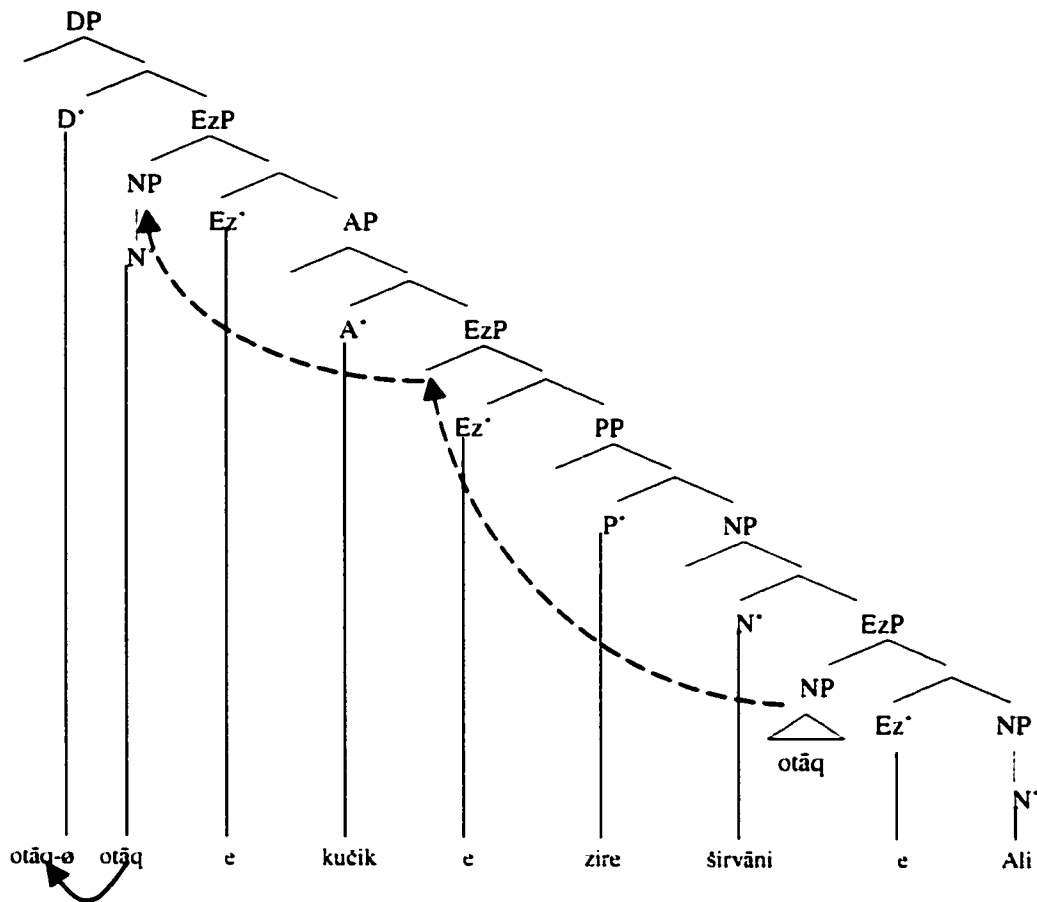

This analysis for EzPs which follows the general Spec-Head-Complement order is similar to the structure of VPs proposed by Larson (1988, 1990), in that N originates in lower shells and then moves up. Also, the movement of the head N<sup>o</sup> as a part of the movement of an XP is similar to the analysis of Shlonsky (2000) for movement in Semitic noun phrases. Supporting evidence for this analysis will be given in Chapter 3.

The most recent work on the Ezafe construction is Ghomeshi (1996, 1997b) whose treatment is based on Ezafe Insertion as proposed by Tabaian (1974) and elaborated in Samiian (1983). She suggests that the presence of the Ezafe vowel<sup>3</sup> is accounted for by a

<sup>3</sup> Ghomeshi (1996) suggests that "to consider the Ezafe vowel as a morpheme is problematic". Throughout her thesis, she refers to the Ezafe morpheme as the Ezafe vowel.

rule inserting it at PF on X's bearing the feature [+N] that are followed by another item (Ghomeshi 1996: p.76). Given that transformations of the kind used in Samiian (1983) are no longer thought to belong to syntax proper, she reformulates Samiian's Insertion Rule (7) as a post-syntactic rule and states that this rule takes place in the spell-out component at PF. Her final version of the Ezafe Insertion Rule (7) is as in (11):

(11) Ezafe Insertion Rule

“Insert the vowel *e* on an X' that bears the feature [+N] and is followed by another non-affixal constituent within the same extended projection.”

Both the analyses of Samiian and Ghomeshi propose solutions based on Ezafe Insertion, an Insertion which appears to be assumed other than syntactically motivated.

### **2.3 The Ezafe Phrase: A Proposal**

The analysis I propose for the Ezafe phrase as sketched in (11) basically differs from Tabaian (1974), Samiian (1983), and Ghomeshi (1996) in that they consider the Ezafe morpheme as a transformationally inserted vowel before each phrasal complement, while I treat the Ezafe morpheme as the head of a phrasal category which serves as the complement of another head. In this regard, I agree with Mahootian (1993) who analyzes the Ezafe morpheme as the head of EzP. But my analysis differs from Mahootian's in that she proposes a small clause analysis for EzP while I treat the EzP as the complement of the head of a non-verbal phrasal category. I will now address the question of why I do not accept Mahootian's (1993) small clause analysis of the EzP.

EzP, as mentioned before, is a structure basically restricted to non-verbal phrasal categories. EzP can be the complement of any N', A', heads of NP and AP. In cases where

there is more than one complement in a nominal phrase which necessitates a movement analysis inside DPs, as we saw in (10), the EzP will be selected by D°, head of DP. In case of PPs, considering the fact that P° is the head of PP, its complement will be an NP which, in turn, has N° as head, and this N° can select another EzP as its complement to the right. On the other hand, inside the EzP, in appropriate positions, there is the possibility to have other EzPs. This point is illustrated in (1e), repeated here for convenience as (12):

- (12) *dānešju-ye alāqemand-e zabānšenāsi*  
*student Ez interested Ez linguistics*  
 “the student interested in linguistics”

In (12), at first, the EzP *ye alāqemand-e zabānšenāsi* “Ez interested Ez linguistics” functions as the complement of the N° *dānešju* “student”, and later another EzP *e-zabānšenāsi* “Ez linguistics” functions as the complement of the A° *alāqemand* “interested”. This recursivity is confined only by the restrictions imposed on the order of the elements inside DP which will be discussed extensively in Chapter 3. The repeatability of EzP is the main factor which prevents us from supposing a small clause analysis for the relevant structure in Persian. To clarify this point, I compare the analysis of an English small clause (13a, b) with a Persian Ezafe phrase. This analysis is from Haegeman (1994) which states that a small clause is in fact a maximal projection of a functional head F, an abstract head which does not dominate overt material:

- (13) a. I consider [<sub>sc</sub> John intelligent].

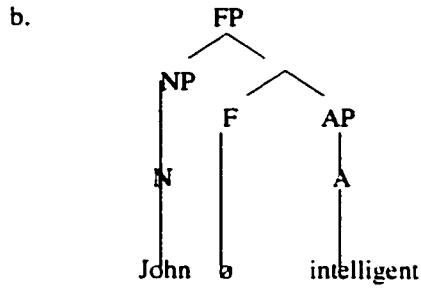

In (13a), the bracketed part [John intelligent] is a small clause, with “John” as its subject and “intelligent” its predicate as shown in (13b). This analysis can be applied to a Persian structure like (12) yielding (14):

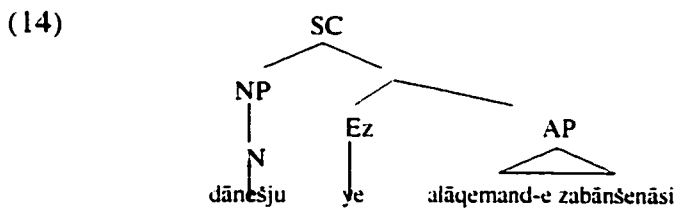

In a small clause analysis of (14), the subject of the small clause is *dānešju* “student”, and its predicate is *alāqemand-e zabānšenāsi* “interested in linguistics”. Up to this point, the analysis is applicable. But when the principle of repeatability of EzP appears, the small clause analysis cannot apply. Therefore, *dānešju-ye alāqemand* “student Ez interested” can not be the subject of a small clause whose predicate is *zabānšenāsi* “linguistics” yielding (15):

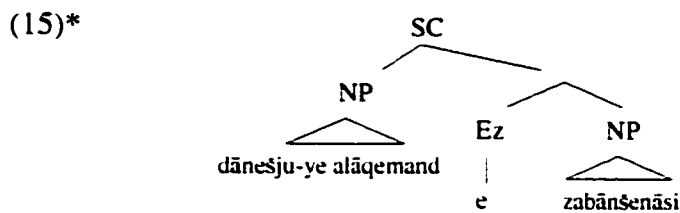

This observation makes me abandon the small clause analysis for this structure and follow the EzP analysis consistently. An additional reason for abandoning a small clause analysis of this construction is illustrates in (16):

- (16) a. *in pesar-e bāhuš*  
 this boy Ez clever  
 "this clever boy"

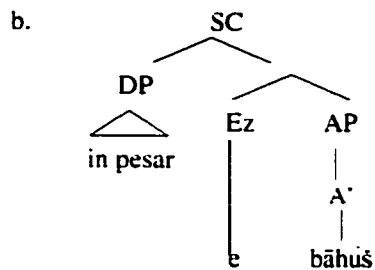

(16b) implies that SC is the maximal projection of Ez. *In pesar-e bāhuš* "this clever boy" is a DP with *in*<sup>4</sup> "this" as its head, and *pesar-e bāhuš* "boy Ez clever" as its complement as shown in (17):

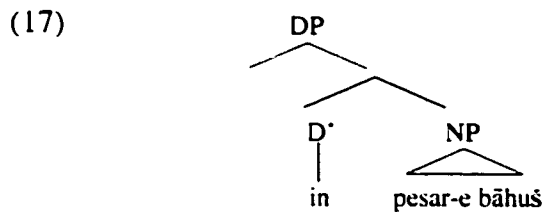

The complement of D\* is an NP headed by N\* *pesar* "boy" and EzP *e bāhuš* "Ez clever" as its complement shown in (18):

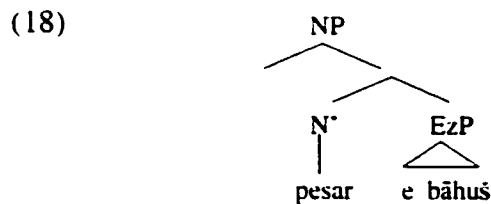

EzP in (18) is a maximal projection headed by *e* with AP *bāhuš* "clever" as its complement displayed in (19):

<sup>4</sup> Supposing *in* "this" as the head of DP is for the sake of argumentation. The realization of D\* in Persian will be discussed later. Cheng & Sybesma (1999) report that Tang (1990) regards Chinese demonstratives as instances of D\* (Cheng & Sybesma: p.527).

(19)

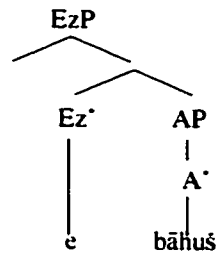

Putting (17), (18), and (19) together, we will have (20):

(20)

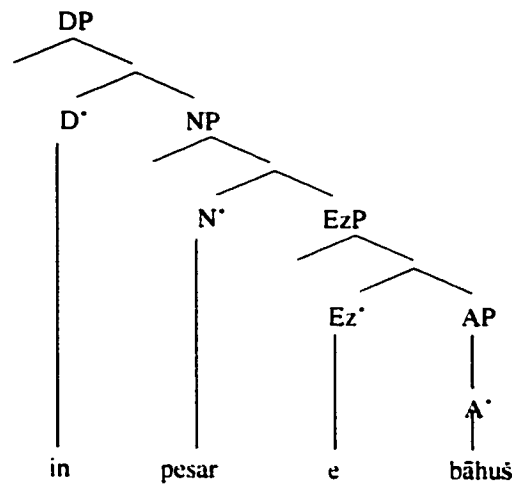

More EzPs can be added to the structure as long as the internal structure of DP allows, an advantage which is absent if we suppose a small clause analysis.

Another point which should be considered in the analysis of EzP is about the phonological positioning of Ez', the head of EzP. In this regard, I agree with Samiiian (1983) that phonologically, the Ezafe is attached to the preceding element, while it is syntactically motivated by the relationship between the head N' or A' and the phrasal modifier; and therefore, it is triggered by the occurrence of the latter. Thus, in (1b), repeated here as (21), the Ez' *e* constitutes a phonological unit with the preceding element yielding *farār-e*, but syntactically, *e* combines with the following element to form the syntactic unit *e bozorg*:

- (21) a. *farār-e / bozorg* (phonological realization)  
 b. *farār / e bozorg* (syntactic categorization)

Generally, researchers (e.g. Samiian 1983: p.33) suggest that the Ezafe morpheme is obligatory, but there are cases where the Ezafe morpheme is absent from its expected position<sup>5</sup>. This fact is illustrated in (22):

- (22) a. *jām jahāni*  
*cup world*  
 "the World Cup"  
 b. *darvāze širāz*  
*gate Shiraz*  
 "Shiraz Square"

The equivalents of (22a) and (22b) are illustrated in (23a) and (23b) with the Ezafe morpheme phonetically realized:

- (23) a. *jām-e jahāni*  
*cup Ez world*  
 "the World Cup"  
 b. *darvāze-ye širāz*  
*gate Ez Shiraz*  
 "Shiraz Square"

---

<sup>5</sup> . Historical evidence, too, implies the optionality of the Ezafe morpheme as the following pairs from Old and Middle Persian show:

(1) Old Persian

a. *kāra māda* (Kent 1953: DB2.16 p.121)  
*army Median*  
 "the Median Army"

b. *kāra hya manā* (Kent 1953: DB2.55 p.122)  
*army Ez I*  
 "the army of mine"

(2) Middle Persian

a. *mard hamrāz* (Abolghassemi: 1996a p.63)  
*man intimate*  
 "the intimate man"

b. *handarz ī man* (Abolghassemi: 1996b p.226)  
*advice Ez I*  
 "my advice"

(23a) is exactly the same as (22a), and so is the relationship between (22b) and (22b). This observation means that the Ezafe morpheme is optional in PF.

The phonetic optionality of the head Ez' is illustrated in (24):

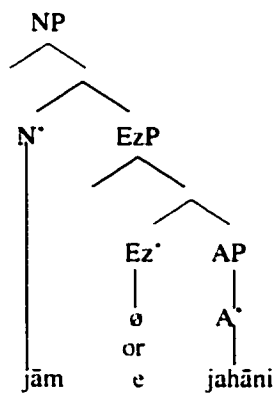
- (24) a. *jām-e jahāni*  
*cup Ez world*  
 "the World Cup"
- b. *jām jahāni*  
*cup world*  
 "the World Cup"
- c. 

The cases of phonetically null Ez' appear similar to a construction found in Arabic, Hebrew, and Russian:

- (25) a. Arabic

*alīn mašqul*  
*Ali busy*  
 "Ali is busy"

- b. Hebrew

*dani (hu) nehmad*  
*Dani (is) nice*  
 "Dani is nice."

- c. Russian

*on zanjat*  
*he busy*  
 "He is busy."

Clearly, in the constructions in (25), the unrealized constituent is the copula "be" whose position in the hierarchical relation of the clause is in Infl, and the structures in (25a, b, c) are equivalent to tensed clauses. The construction under investigation in Persian differs

from these constructions in that its head, present or null, is not placed in I', but it is the head of the phrase EzP which is the complement of an N' or A' lacking features relative to I'. In fact, the parallel construction for (25a, b, c) is ungrammatical in Persian as shown in (26):

- (26) a. gol    zibā    ast  
           *flower beautiful is*  
           "Flower is beautiful."  
       b. \* gol    zibā

In the analysis I have proposed thus far, the Ezafe construction is actually the projection of the head Ezafe, phonetically realized as *e*, or *ye* or  $\emptyset$  which subcategorizes for its complement to the right from all non-verbal phrasal categories. This maximal projection which I call Ezafe Phrase or EzP is a functional category, clearly a head-initial phrase, with a non-filled Spec, as shown in (27):

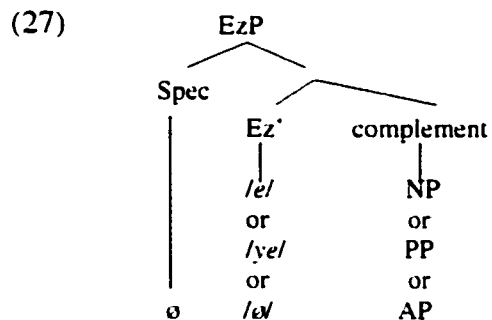

The unfilled Spec poses no problem for EzP, as we are familiar with such cases in other phrases such as TP (in Chomsky 1995). However, it is more plausible to follow Chomsky (1999) and consider the EzP a defective category which has no EPP features, thus no Spec. Supposing the EzP as a defective category reflects its characteristics better, but in order to have a parallelism between the EzP and other phrasal categories, I keep on using the foregoing structure in (27) for the EzP. In addition, as we saw in the analysis of complex structures like (10), in multi-complement DPs, N' originates in the Spec of the lowest EzP;

and the intermediate EzP(s) are the positions which preserve the semantic relation between  $N^{\circ}$  and its different complements; and Spec of the highest EzP is the landing site for  $N^{\circ}$  as discussed in the analysis of (10). As for the case where the head of EzP is null, the same reasoning is applicable. This is not the first time in generative grammar that a functional phrase is proposed with a phonetically unrealized head. Following Cinque's (1995) analysis of attributive adjectives as specifiers of a functional head  $F^{\circ}$ , Radford (1997) proposed that attributive adjectives are contained within a functional projection FP which has an empty functional head, as illustrated in (28):

(28) a. a new chair

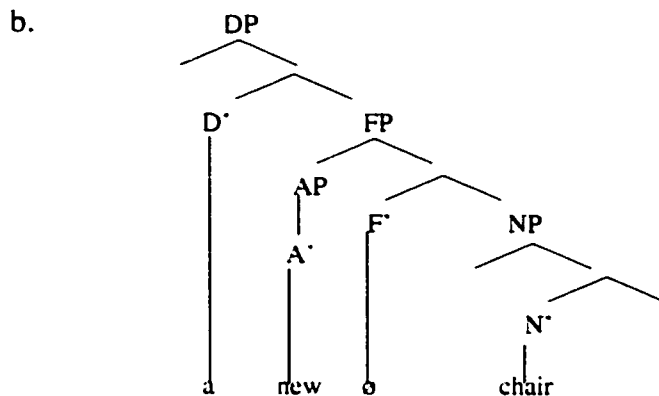

As (28b) shows, FP is a functional phrase selected as the complement of  $D^{\circ}$  with a null head  $F^{\circ}$ .

EzP, in turn, can be the complement of any supercategory [+N], as classified in Chomsky (1970). That is to say that any  $N^{\circ}$  or  $A^{\circ}$  can select an EzP as its complement to the right, a feature that  $V^{\circ}$  and  $P^{\circ}$  are lacking. No. (29) illustrates the case of EzP as the complement of  $N^{\circ}$  and  $A^{\circ}$ :

(29) a. farār-e bozorg  
*escape Ez great*  
 "the great escape"

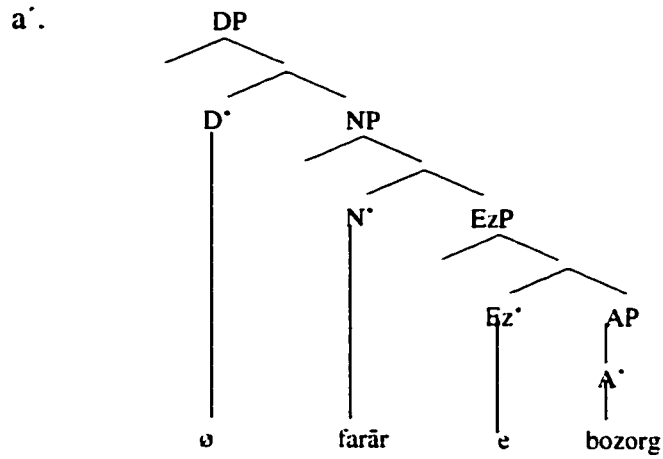

b. alāqemand-e musiqi  
*interested Ez music*  
 "interested in music"

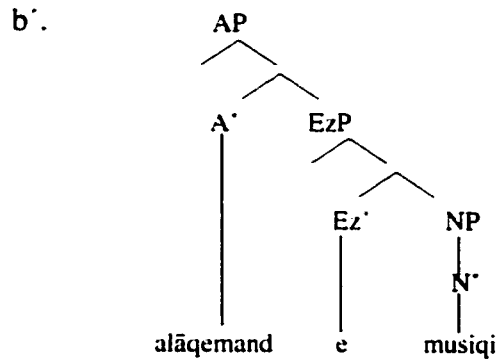

c. violonzan-e ruye bām  
*fiddler Ez on roof*  
 "fiddler on the roof"

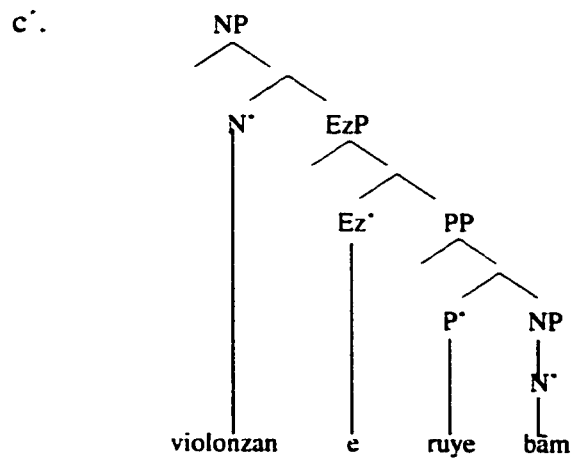

In the case where there is more than one EzP in a DP which implies a multi-complement N° in the nominal phrase, in order to preserve the selectional properties of the head and its complements, I propose a movement analysis. As displayed in (10), in such complex DPs, N° originates in the Spec of the lowest EzP as the head of an NP. This analysis establishes the semantic relations between N° in the Spec of the lowest EzP, i.e. *otāq* “room”, and the NP which is the complement of the lowest Ez°, i.e. *Ali*. The same N° moves up together with the other elements of the same phrase as an NP in order to establish the semantic relations with other complements of the DP. The only available slot for this XP to move to is the Spec of the intermediate EzP, because other Specs in its way are potentially filled by appropriate XPs which I will survey in the analysis of DPs. In the last step, for the same purpose, the NP containing the N° *otāq* “room” moves higher up and ends in the Spec of the highest EzP and establishes the selectional properties of N° with the highest complement in the DP. The PF realization of N° as the head of the NP in the Spec of the highest EzP yields the word order of the DP in (10a). In the analysis of nominal phrases, I will present the supporting evidence regarding this movement analysis.

To sum up, I proposed a novel maximal projection for Persian, headed by a phonetically present (*e/ye*) or absent ( $\emptyset$ ) morpheme with a complement to its right. The complement of the head can be any non-verbal phrasal category. This maximal projection which I called Ezafe Projection or Ezafe Phrase or EzP is a functional category which by the operation Merge can be the complement of any [+N] supercategory, i.e. N° or A°. In case of multi-complement DPs where EzP is selected as the complement of D° to its right, the same generalization is observed. This analysis of the previously called Ezafe construction follows

LCA based theoretical assumptions which suppose a head-initial status for all phrasal categories and gives a consistent syntactic analysis of this structure in Persian.<sup>6</sup>

---

<sup>6</sup> In addition to the analysis followed in this research, there is an alternative with only one structure for a DP, regardless of the number of post-N' complements. This issue is addressed in Chapter 3, p. 74-76.

## Chapter 3

### Persian Nominal Phrases

This chapter investigates nominal constructions in Persian. In section 3.1, I introduce the DP Hypothesis and discuss that a nominal phrase is indeed the projection of  $D^\circ$ , head of a DP. In 3.2, I claim that analyzing Persian nominal phrases as DPs best reflects the nature of these maximal projections. I also present the elements which head a DP. In 3.3, the elements occurring in Spec DP and Spec NP are surveyed. In 3.4, I present the structure of the post- $N^\circ$  modifiers and propose two analyses based on the number of the elements following  $N^\circ$ . I argue that in the case where there is one post- $N^\circ$  modifier,  $D^\circ$ , the head of the DP, subcategorizes for an NP as its complement; but when there is more than one post- $N^\circ$  complement,  $D^\circ$  selects an EzP as its complement and  $N^\circ$  originates in the specifier position of the lowest EzP, and moves up and lands in the specifier position of the highest EzP. This process moves  $N^\circ$ , as the head of an NP in the Spec of the lowest EzP, together with its own Spec. It is an instance of the movement of maximal projections and yields the PF realization of the DP. Finally, 3.5 outlines the conclusions.

#### 3.1 Introduction

In generative grammar, it was first assumed that noun phrases are the projection of the head noun in the phrase while other constituents such as articles, demonstratives, quantifiers, adjectives and numerals are all modifiers of the  $N^\circ$ . This view locates Determiner Phrases inside NPs, in particular in their specifier position as shown in (1):

(1) [<sub>NP</sub> DP[<sub>N'</sub> N]]

This view was initially challenged by Brame (1981) who proposed that the head of NP is the determiner not the noun as commonly assumed, a structure better represented as a DP rather than an NP. Subsequent works by Szabolcsi (1983), Abney (1986), and Fukui & Speas (1986) elaborated this idea and concluded that within the DP the N is, in fact, the complement of the head D. This hypothesis brings about (2) as the structure of any nominal phrase:

(2) [<sub>DP</sub>[<sub>D'</sub> D NP]]

An important contribution to the development of the DP Hypothesis was the observation by Abney (1986) that there was a symmetry between nominal and clausal projections. He states that in the same way that clauses reduce to projections of the lexical VPs dominated by the functional projection IP, the category NP should be seen as a projection of N dominated by a functional projection DP. This functional projection DP is the projection of its non-lexical, functional head D which projects to a DP configuration in (2). Supporting evidence for the analysis of determiners as head-like functional elements is the fact that determiners belong to a closed class, contrary to nouns which comprise an open class, and they are typically one-word elements which in some languages are realized as bound morphemes.

Following the above discussion, I conclude that in the general case a Noun Phrase (NP) is a Determiner Phrase (DP) which is the extended projection of an N, head of NP which in turn is the complement of D'. Due to the fact that in Persian the head of DP is either a bound morpheme, *pesar-e* "the boy", or is null, *pesar* "the boy", I use the term "nominal phrase" interchangeably with DP to distinguish it from the base (determinerless) NPs.

In addition to the discussion above which led us to choose the DP Hypothesis displayed in (2) in UG, Longobardi (1994) argues that if movement can be applied in some language from inside the NP to a position inside the DP (e.g. from specifier position to specifier position or from the position of N' to that of D'), then the structure in (1) will immediately be discarded, under any current theoretical approach, by the ban against movement to a non-c-commanding position. He presents examples to show that movement from N' to a higher functional head, e.g. to D', has been tentatively argued to apply in Semitic and Scandinavian. This line of argument concludes that due to the applicability of movement in a nominal construction and also the impossibility of such movements in the structure in (1), its alternative, i.e. the structure in (2), will naturally portray the structure of any nominal phrase. It is what Longobardi (1994) examines in Western Romance indicating instances of N-to-D movement which support the structure in (2) and the theory of head-movement.

Another important issue discussed by many researchers working on nominal phrases, e.g. Stowell (1989), Szabolcsi (1994), Longobardi (1994), and others, concerns the licensing of bare (determinerless) NPs. After giving examples from Italian, Longobardi concludes that "a nominal construction is an argument only if it is introduced by a category D (Longobardi 1994: p.620)", or in other words, only DPs can function as arguments. This obligation entails that argument positions in a sentence (e.g. subject, direct object, prepositional object, inverted subject of either ergative or unergative predicates) should be necessarily filled by DPs, while nominals in typical nonargumental functions such as vocative, predicative or exclamatory contexts do not have such a constraint. This characteristic is illustrated in (3), where (3a) indicates that the subject position should be

filled by a DP, while (3b) shows that there is no constraint on the choice of the nominal in predicative contexts:

- (3) a. \*(Un/Il) grande amico di Maria mi ha telefonato.  
*(a/the) great friend of Maria called me up*
- b. Gianni è tenente.  
*Gianni is lieutenant*

Recently, Chierchia (1998) has argued against the generality of the claim that “argument positions should be filled by DPs” stating that “in some languages (like Chinese), NPs are argumental and can thus occur freely without a determiner in an argument position.” This idea has been challenged by Cheng & Sybesma (1999) who argue that bare nouns in Chinese are never bare in structure and that [classifier + noun] phrases may have more structure than just a Classifier Phrase. The latter claim supports the widespread notion that only DPs can be arguments.

As I mentioned earlier, head-to-head movement in DPs has been tentatively argued to apply in Semitic by Ritter (1988), Ouhalla (1988), Fassi Fehri (1989), Siloni (1989,1990) among others. Shlonsky (2000) presents a new analysis for the movement process inside DPs. Based on the LCA assumptions proposed by Kayne (1994) that “head-to-head raising must invariably be leftward” and “the adjoining head adjoins to the left of the adjoined head”, Shlonsky rejects N°-to-D° movement in Semitic languages. Shlonsky’s fundamental argument against N°-to-D° movement for Semitic noun phrases stems from the fact that if N° moves to D°, the outcome of this movement will be N°+D° order, contrary to the actual order of Semitic noun phrases which is D°+N° as shown in (4):

- (4) al banāt (Arabic)  
*the girls*  
*“the girls”*

Therefore, he rules out N'-to-D' movement for these languages. Instead, he argues that although N' moves up, its landing site is below D'. He calls this process "Partial" N-movement which moves N' to a position like the one illustrated in (5):

- (5) a. D...>... Card # P ...>... AP...>... PPgen ...>... N
- 
- b. al xamas banāt zakīyyāt  
*the five girls smart*  
 "the five smart girls"

Finally, after banning N'-to-D' movement and applying Partial N-movement as a middle process, he claims that "head-movement derivation is unable to explain the constraints on word order without a substantial number of auxiliary ad hoc assumptions. On the other hand, phrasal movement explains this better." In sum, Shlonsky suggests that N moves up, as a part of a phrasal movement which carries the head N' together with other components of the phrase to a higher position. Although Shlonsky's analysis rules out N'-to-D' movement in Semitic, his main line of argumentation can serve to support head movement in the Persian DPs which I discuss in the next section.

### 3.2 The DP Hypothesis and Persian Nominal Constructions

In the previous section, I presented analyses supporting the DP Hypothesis, and concluded that NPs should be seen as DPs. In this section, I apply the relevant argumentation to Persian, and show that the DP Hypothesis optimally describes nominal constructions in this language.

Linguists working on syntactic structure in Persian have generally adopted the DP Hypothesis. Karimi (1989), assuming the determiner, not the noun as the head of the nominal phrase, proposes (6) as the structure of Persian DPs:

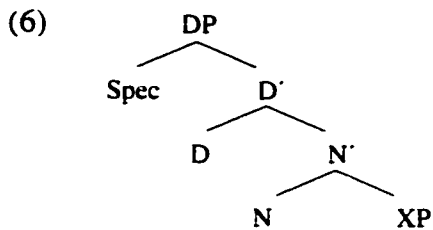

She proposes that numeral determiners and quantifier determiners are base generated under the head node  $D'$ . Demonstratives are generated under the node Spec and close off the projection. In her analysis, the nominal phrase in (7a) will have the relevant structure in (7b):

(7) a. in se tā ketāb  
*this three classifier book*  
 "these three books"

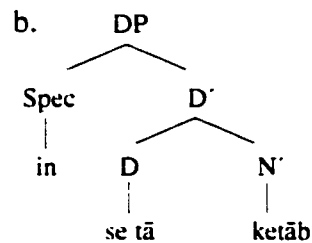

The main difference between Karimi's analysis of DPs and my proposal concerns the elements which can potentially act as a head, a crucial issue which I will discuss later in this section.

Mahootian (1993) adds NumP as the complement of  $D'$  to the structure she proposes for DPs and renames Karimi's  $N'$  as Plural Phrase (PLP). This analysis produces (8b) as the relevant structure for the DP in (8a):

(8)

a. in do-tā gorbe-hā  
*this two-classifier cat-PL*  
 "these two cats"

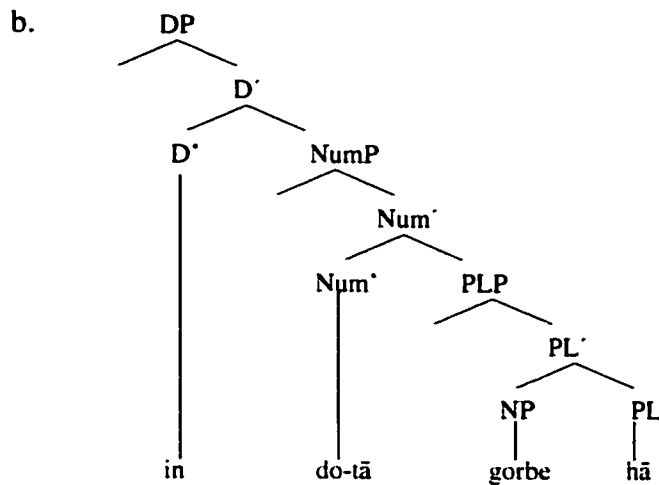

In her analysis, demonstratives are generated under  $D^{\circ}$ , and numerals under  $Num^{\circ}$ . My proposal differs from Mahootian's in two respects. First, the elements that head the DP are essentially different. And second, the PLP in Mahootian's analysis is headed by  $PL^{\circ}$  which selects an NP as its complement. A closer look at  $PL^{\circ}$  and its complement shows that PLP has two heads: the  $PL^{\circ}$  *hā* "plural marker" and an  $N^{\circ}$  *gorbe* "cat". Giving the status of a maximal projection to the head *gorbe* "cat" does not solve the deficiency of Mahootian's analysis, but adds to problems. Mahootian could overcome this inadequacy if she considered the PLP as a head-initial phrase headed by the plural marker *hā* which selects an NP as its complement to the right. Then, the head of the complement moves up and adjoins to the left of  $PL^{\circ}$  producing the word order of the phrase as partially shown in (9):

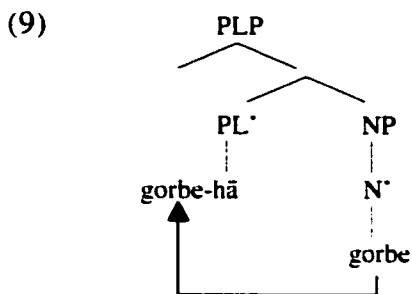

Considering the fact that the main difference in my analysis of DPs and Mahootian's (and also Karimi's) is about the elements that head the DP, solving this deficiency will not affect the structure I propose for Persian nominal phrases.

Ghameshi (1996) adopts the DP Hypothesis and presents the most comprehensive account of the elements that head a DP. She suggests that these elements include proper names and pronouns, the indefinite enclitic *-i*, the empty definite D-head, the plural marker *hā* and the colloquial marker *-e*. As I will show later, three of these elements, the indefinite enclitic *i*, the colloquial marker *e*, and the empty definite marker  $\emptyset$  are the same elements that project the DP and head the nominal phrase in my analysis. Although I accept the common analysis of proper nouns and pronouns as heads of DPs, I do not consider the plural marker *hā* can be a DP head. In my analysis, the plural noun is selected from the lexicon together with its plural marker. Apart from my disagreement with Ghameshi regarding the plural marker, our main difference lies on the directionality of the head  $D^{\circ}$  relative to its Spec and Complement. She argues that  $D^{\circ}$  occurs on the right as can be seen, for example, in (10) where  $D^{\circ}$  is the null definite marker:

(10)

a.     ketāb  
           *book*  
           "the book"

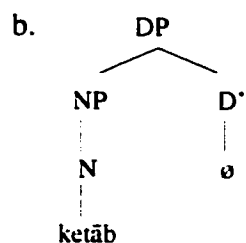

The head-final analysis for Persian DPs contradicts Ghameshi's statement that "in Persian, only the verb takes its complement to the left. Thus, for all other categories the non-recursive side is on the left" (Ghameshi 1996: p.45). Nevertheless, in order to solve this

contradiction, in a footnote, she considers the DP headed by the null definite determiner as a counterexample to this general claim (Ghomeshi 1996: p.77, footnote 23). I will argue later that the head-to-head movement in Persian nominal phrases strictly necessitates a head-initial analysis for DPs in this language, and justifies the occurrence of the other realizations of  $D^\circ$ , as *e* and *i*. This fundamental issue will be discussed in the next section.

Some linguists, e.g. Darzi (1995) and Vahedi (1996), continue using NP as the NP/DP distinction apparently makes no difference in their analyses. Selection of a DP or NP configuration for noun phrases is not stylistic. It should be based on robust evidence, and should also follow current theoretical reasoning (prerequisites frequently neglected in the analysis of this phrasal category in Persian).

Definiteness and indefiniteness in Persian are realized by the bound morphemes /e/ and /i/. These are the elements that I assume head the phrase and project DP. Clearly, the main characteristics of determiners can be observed in these two elements: they are one-word elements and they belong to a closed class. Their third feature, i.e. their occurrence as bound morphemes, makes them absolutely similar to determiners in some languages like Scandinavian. No. (11) illustrates this similarity in Swedish and Persian.

- |      |                                          |                   |
|------|------------------------------------------|-------------------|
| (11) | a. <u>Swedish</u> (Haegeman 1994: p.608) | b. <u>Persian</u> |
|      | flick -n                                 | doxtar-e          |
|      | girl Det                                 | girl Det          |
|      | "the girl"                               | "the girl"        |

The peculiarities of (in)definite determiners in Persian and the parallelism observed between nominal constructions in this language and languages like Swedish in which these constructions have been analyzed as DPs support the DP Hypothesis for Persian. In addition to this argumentation for a DP analysis, the order  $N^+D^\circ$  in (11b) indicates a head-to-head movement in the DP which supports the structure in (2) and rules out (1) as discussed by

Longobardi (1994) and mentioned earlier. This movement carries N° to D° and adjoins it to the left of the target, exactly as predicted by the LCA which states that the moved element adjoins to the left of the host. Also, this movement occurs in syntax and therefore is overt, a feature compatible with Kayne's (1998) claim that all movements are overt. Shlonsky (2000) ruled out N°-to-D° movement for Semitic NPs because N° movement to D° would result in N°+D° order, and the order in Semitic languages is D°+N°. The very argumentation he uses to support the ban on head-to-head movement in Semitic, provides support for N°-to-D° movement in Persian and puts N° before D° in the phrase.

From the argumentation presented up until now, I propose that in conformity with LCA assumptions which impose a general Spec-Head-Complement, a Persian DP will be realized as the configuration in (12):

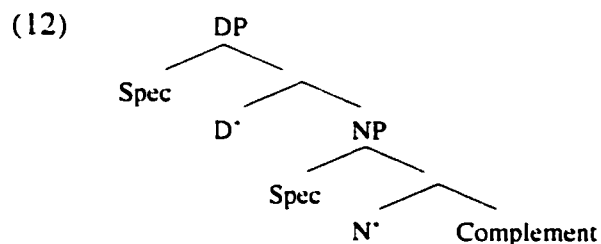

That is to say, D° subcategorizes for its complement NP to the right, and then projects a DP with its Spec to the left of the head D°. NP, in turn, is the projection of the head N° selecting its Complement to the right and with its Spec to the left. Both Spec and Complement are maximal projections whose internal structures obey the general regulations adopted for any phrasal category.

As mentioned earlier, the members of the closed class of Persian determiners which head a DP are *le/* and *li/*. The bound morpheme *le/* is restricted to Colloquial Persian and heads definite, singular DPs. In the literature, it is called the definiteness marker (Samiian 1983, Meshkat al-Dini 1987, Karimi 1989, Ghomeshi 1996). The other element which

heads the DP is the determiner */i/*. Ghomeshi (1996) calls */i/* an indefinite enclitic which is a determiner heading the DP. Unlike the indefinite “a/an” in English but similar to “some”, it may co-occur with plural marking (Ghomeshi 1996, Meshkat al-Dini 1987, Bateni 1969). No. (13a) illustrates a definite, singular DP, (13b) illustrates an indefinite singular DP and (13c) shows an indefinite plural DP:

- (13) a.        *pesar-e*  
               *boy Definite Det*  
               “the boy”
- b.        *pesar-i*  
                       *boy Indefinite Det*  
                       “a boy”
- c.        *pesar-hā-i*  
                       *boy PL-Indefinite Det*  
                       “boys” (indefinite)

Definite DPs sometimes lack a phonologically realized D’ as shown in (14):

- (14) *pesar*  
        *boy*  
        “the boy”

This fact has been mentioned by Meshkat al-Dini (1987) and Ghomeshi (1996) where the latter calls it the null definite determiner. Chierchia (1998: p.355) claims that “it is of course conceivable that a language has a phonologically null D’”, and Longobardi presents some observations to suggest that an empty category in need of some kind of lexical government is necessarily present (Longobardi 1994: p.617). Earlier, I argued for head-to-head movement for Persian DPs (p.53-5). In this movement, N’ moves to D’ and produces the actual order N’+D’ in Persian DPs (No.15 displays this process). In the case where D’ is not phonologically realized, again, N’ moves to D’ satisfying the condition just mentioned from Longobardi (1994). Contrary to my proposal, Ghomeshi (1996) in spite of accepting a null determiner does not treat N to D movement (Ghomeshi 1996: p.115). Her head-final analysis for DPs without any movement was shown earlier (No.10).

To conclude this section, Persian DPs are headed by /e/, /i/ or /ø/ which select an NP as their Complement to the right. Then, N°, the head of the NP overtly moves to D°, yielding the actual N°+D° order. This process<sup>1</sup> will produce the trees in (15) for different cases of DPs in (13a), (13b) and (14):

(15) a. Tree for (13a)

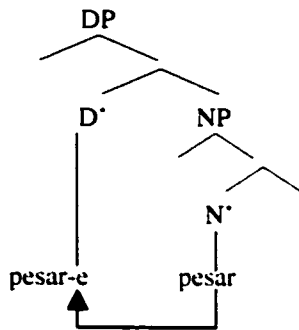

b. Tree for (13b)

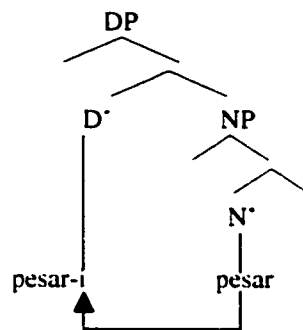

c. Tree for (14)

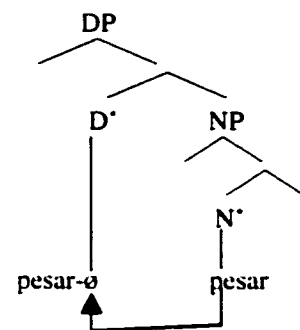

In this section, the applicability of the DP Hypothesis to Persian nominal phrases was investigated and the peculiarities of D° in addition to the elements occupying this position were surveyed. In the next section, the elements preceding N°, those found in Spec DP and Spec NP will be investigated.

### 3.3 Is there any restriction to the elements preceding N°?

Up until now, I have argued in favor of supposing a DP analysis for Persian nominal phrases based on four pieces of evidence: a) the general theoretical foundations proposed for the DP Hypothesis; b) the LCA-based analysis adopted in this thesis; c) the recent treatments of this category in the study of Persian syntax; and d) the position of the elements I consider as the

<sup>1</sup> The same line of argumentation has been followed in the study of nominal phrases in other languages. Head-to-head movement in DPs has been proposed with satisfactory results for the Semitic languages by Ritter (1988), Ouhalla (1988), Fassi Fehri (1989) and Siloni (1990); for Scandinavian by Delsing (1988), Taraldsen (1990) and Holmberg (1992); and for Romanian by Grosu (1988) and Dobrovie-Sorin (1987).

head of DP which have generally been neglected in other analyses of DPs. Having these facts in mind, my proposal for Persian DPs leads to the following configuration for this category:

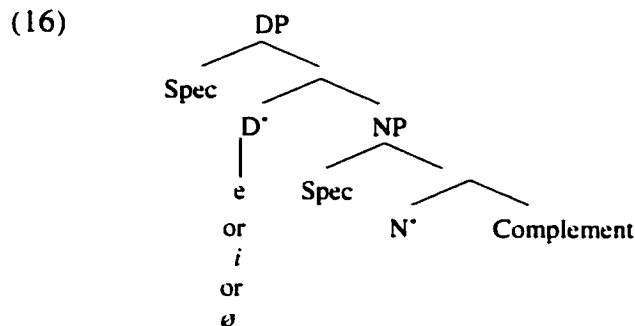

In (16), DP is the projection of the head D' with its Spec to the left and its complement NP to the right. NP, in turn, is the projection of the head N' with its Spec to the left and its Complement to the right. The specifier positions of DP and NP may be filled with specific elements, and in fact, the constituents occupying the available slots before N' are so restricted that they give a fixed structure to the pre-nominal modifiers of the head of NP, complement of D'. At the same time, the inflexibility observed in the order of these elements is justifiable in the configuration proposed for this category in Persian. I will now examine the elements occurring before N', i.e. Spec DP and Spec NP.

As previously mentioned, the elements occupying Spec DP are limited. In order to classify these elements and determine the category to which they belong, I will first identify them. They include: *in* "this", *un* "that", *har* "every", *čand* "some", *hame* "all", numerals, or a combination of *in* "this", *un* "that", and *har* "every" plus a numeral, and one of the classifiers such as *botri* "bottle", *metr* "meter", *nafar* "person". No. (17) displays cases where more than one element fills Spec DP:

- (17) a. *in yek pesar*  
*this one boy*  
 “this one boy”
- b. *un do tā deraxt*  
*that two classifier tree*  
 “those two trees”
- c. *har se tā ruznāme*  
*every three classifier newspaper*  
 “all three newspapers”

Due to the proposal argued for in the previous section that D° heads the DP, and considering the fact that a phrase has one and only one head, the conclusion is that Spec DP is not filled with an X°, but with an XP. The constituent in Spec DP may be one of the following maximal projections: a Demonstrative Phrase (DemP), a Quantifier Phrase (QP), or a Number Phrase (NumP).

The first two possible occupants for the Spec DP position are the demonstratives *in* “this” and *un* “that”. Placing demonstratives above D° is justified by the co-occurrence of the definite article and demonstratives in some languages as the Swedish example in (18) shows:

- (18) *den mus - en*  
*that mouse the*  
 “that mouse”

Supposing the determiner *en* “the” as D° in (18) indicates that the demonstrative *den* “that” should fill a higher position, necessarily a Spec above N° in the nominal phrase. Evidence for locating demonstratives in specifier positions within the DP is discussed by Giusti (1992) for Romanian and German, and Brugè (1995) for Spanish. No. (19) illustrates such cases where a demonstrative heads a DemP in Spec DP:

- (19) a. un pesar  
*that boy*  
 "that boy"

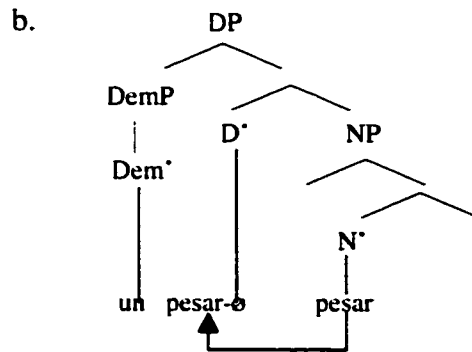

As (19b) shows, head-to-head movement adjoins N' to the phonologically unrealized D' and Spec DP is filled with the DemP which is the projection of the Dem\* *un* "that". In addition to (19) in which D' is null, (20) exemplifies a case where D' is realized as /e/:

- (20) a. un pesar-e  
*that boy - the*  
 "that boy"

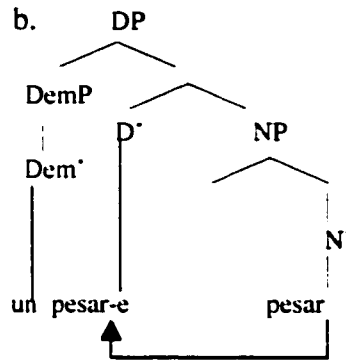

These observations reaffirm the head-to-head movement in Persian DPs, and show the co-occurrence of the demonstratives and the definite D'. This aspect makes languages like Persian and Swedish different from Bulgarian which does not allow Dem\* and D' to coexist as displayed in (21):

- (21) Bulgarian<sup>2</sup>
- \*tazi zena-ta  
*this woman-the*  
 "this the woman"

<sup>2</sup> Example (21) is from Arnaudova (1995)

The other category which can potentially fill Spec DP is a QP which is in complementary distribution with DemP. Persian QPs are the projections of the heads *har* “every”, *čand* “some”, and *hame* “all”. No. (22) exemplifies a case where Spec DP is realized by a quantifier:

(22) a. *hame* *pesar-hā*  
*all boy-PL*  
 “all boys”

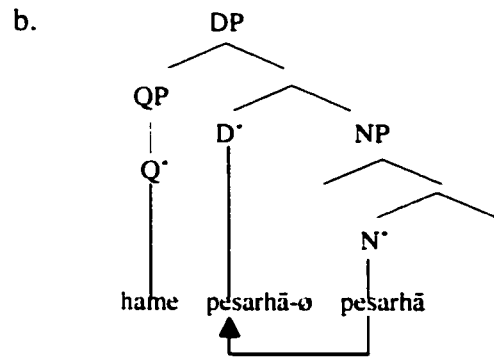

The universal quantifier *hame* “all” does not always appear in Spec DP as the head of the QP. It can also select an EzP complement which appears to the right as illustrated in (23):

(23):

(23) *hame-ye un pesar-hā*  
*all Ez that boy-PL*  
 “all those boys”

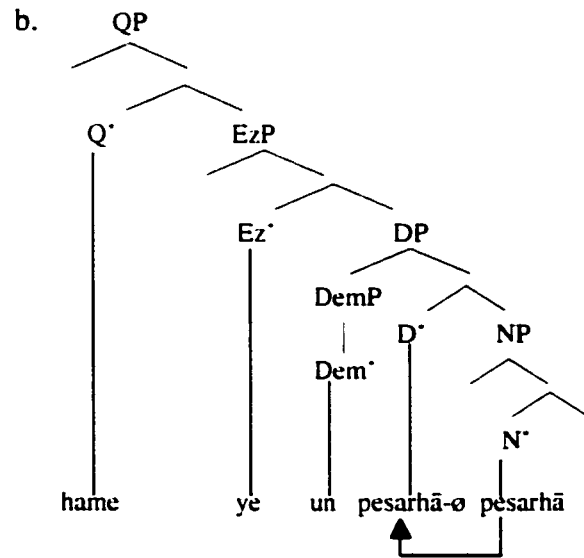

As (23b) shows, Q', head of the QP, subcategorizes for an EzP complement. This behavior of Q' in selecting an EzP complement parallels that of N', head of NP as discussed in Chapter 2. It can be assumed that quantifiers have a [+N] feature.

NumP is the last phrasal category which fills the specifier position of Persian DPs. The analyses of Mahootian (1993) for Persian as shown in (No.8), and Ritter (1991) for Hebrew have proposed NumP as the complement of D°. Although Ritter's proposal for generating NumP between DP and NP has brought about satisfactory results for other languages, generating NumP as the complement of D° produces ungrammatical strings for Persian nominal phrases. The outcome of applying Ritter's proposal for (24a) will be (24b) which is ungrammatical:

(24)

a. *yek pesar-i*  
*one boy-indefinite determiner*  
 "one boy"

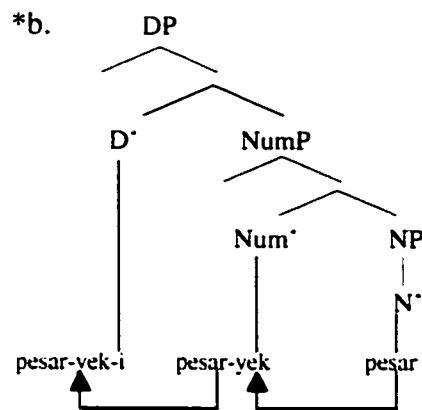

In (24b), NumP is located between DP and NP. In this tree, *pesar* "boy" is N°, *yek* "one" is Num° and D° is *i* "indefinite article". Head-to-head movement adjoins *pesar* to the left of Num°, yielding the string *pesar-yek*. The same process, then, moves that string higher up and adjoins it to the left of *i* producing the string *pesar-yek-i* which is ungrammatical. But assuming NumP in the specifier position of DP produces grammatical results. My analysis for (24a) is shown in (25):

(25)

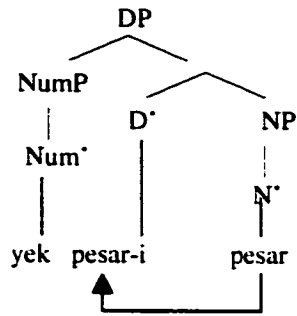

In (25), head-to-head movement adjoins *pesar* “boy” to the left of  $D^\circ$  *i*, yielding *pesar-i*. With *yek* “one” as the head of NumP which fills Spec DP, the grammatical string *yek pesar-i* “one boy” is produced. This observation leads me to propose that whenever there is Num° in a nominal phrase, it is located in Spec DP. In a simple case like (25), the exclusive constituent of NumP is its head which fills Num°. But this is not always the case, as other projections can be present in the specifier and complement positions of the NumP. Therefore, in a nominal phrase, if a demonstrative precedes the Num°, it is the head of a DemP which occupies the specifier position of the NumP, which, in turn, is the specifier of the DP. This case is shown in (26):

(26) a. un do pesar  
that two boy  
“those two boys”

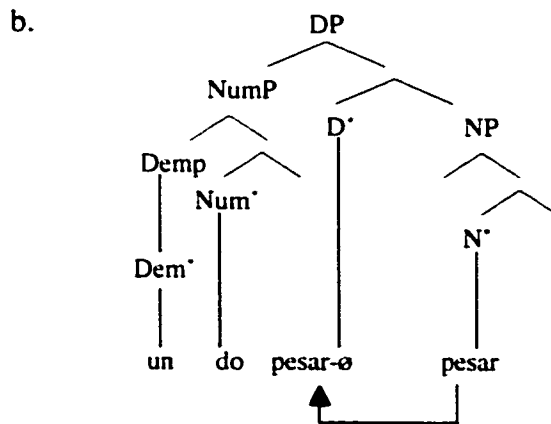

In the more complex case where a classifier follows Num°, it is the head of a ClassP which is selected as the complement of Num° to the right. The case in which all three constituents of the NumP are present is illustrated in (27):

(27)

a. un do tā pesar  
*that two classifier boy*  
 "those two boys"

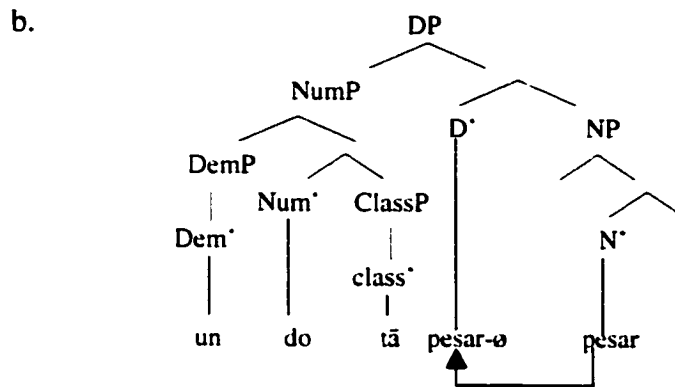

The analysis presented here places DemP, QP, NumP and ClassP to the left of D°, that is, in Spec DP. As mentioned earlier, these XPs have usually been located lower than D° and above N°, as proposed in Ritter (1991) for Hebrew and Mahootian (1993) for Persian. In their analysis of Chinese, Cheng & Sybesma (1999) add another maximal projection to the tree and propose the following structure for Chinese DPs:

(28)

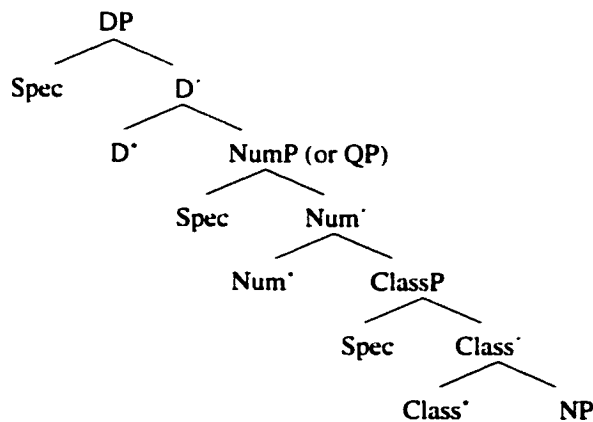

I ruled out this analysis for Persian based on the observation elaborated in relation to (24) which necessitates the generation of DemP, QP, NumP and ClassP in Spec DP. My analysis accounts for the possibility of these four maximal projections within the DP in Persian, and supports the LCA assumptions that the specifier position of any maximal projection is to the left of its head and is filled with another XP.

So far, Spec DP and D' have been analyzed. Now, it is time to investigate the complement of D', which is, by definition, an NP. Similar to DP, this NP follows the LCA principle of Spec-Head-Complement. The head of this NP is a noun, which prior to DP analysis, was considered to be the head of what is now referred to as a DP. The Spec of this NP is an AP whose head A' is its only phonetically realized constituent. Supposing AP in Spec NP has been followed by others for some languages. Theoretically, Kayne (1994) argues that "adnominal adjective phrases that are not complements must then be specifiers" (Kayne 1994: p.137). He suggests, "APs can be generated in specifier positions", and concludes that, "APs are generated above N' in Spec NP" (Kayne 1994: p.100). Among others who have argued for generating APs in Spec NP, Longobardi (1994) and Cinque (1995) are prominent. There are two types of adjectives occurring in this position: superlatives and ordinal numbers which are in a complementary distribution, as displayed in (29) and (30), respectively:

- (29) a. in bozorgtarin pesar  
*this biggest boy*  
"this biggest boy"

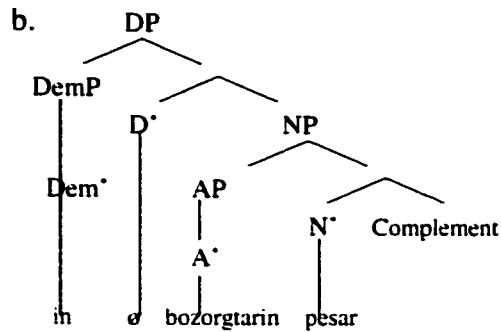

(30)

a. dovvomin hafte  
*second week*  
 "the second week"

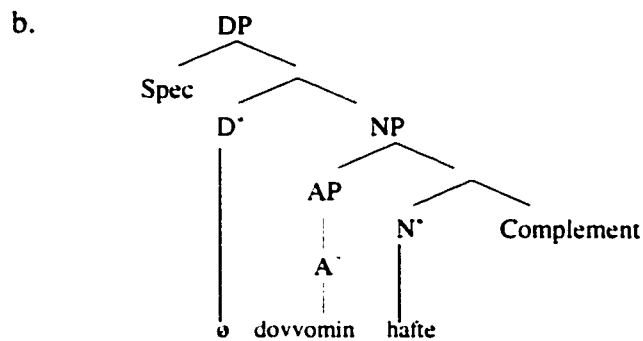

In addition to superlatives and ordinal numbers, a very small set of individual adjectives, among which *yegāne* and *yektā* (both meaning "unique") are the most frequent, appear in Spec NP. Except for these APs which are generated in Spec NP, the majority of Persian attributive APs are post-nominal. As discussed in the chapter on the EzP, post-N' APs modify N' in an Ezafe construction. The occurrence and behavior of these APs is elaborated further in the discussion of post-N' modifiers.

As discussed in Chapter One, based on the Linear Correspondence Axiom (LCA), each phrase has only one Spec to the left<sup>3</sup>. I propose that this principle applies to all Persian phrasal categories. There is only one case which should be scrutinized and reanalyzed. In (30), the NP which is the complement of D<sup>\*</sup> has one Spec. Apparently, this is not always the case, as N<sup>\*</sup>, the head of NP can have another Spec which is filled by an AP or NP. Examples of this are shown in (31a) and (32a), and their proposed structures (for the NPs only) are shown in (31b) and (32b), respectively:

- (31) a. *behtarin qahve xāne*  
*best coffee house*  
 "the best coffee shop"

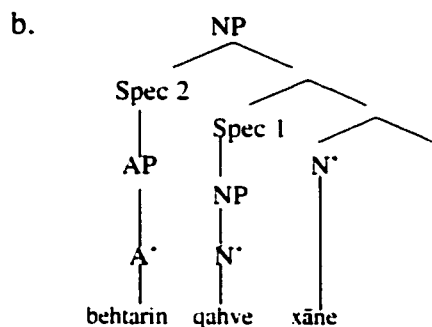

- (32) a. *mahbubtarin noxost vazir*  
*most popular prime minister*  
 "the most popular prime minister"

<sup>3</sup> Following Chomsky (1995), Cinque (1996), in his review of Kayne's theory, states, "it could well be that natural languages allow for phrases with multiple specifiers." Then, he suggests, "in fact, a definition of c-command slightly different from the one assumed in LCA would seem to achieve just that, while retaining most other features of Kayne's system." Nevertheless, he accepts that if the one specifier/ one head theory is empirically adequate, it will be more restrictive and hence should be preferred. Interestingly, when he changes the definition of c-command, he observes that it is "empirically an undesirable move which results in the loss of some properties of LCA, a conclusion directly denoting the preference of one specifier/one head" (Cinque 1996: p.450).

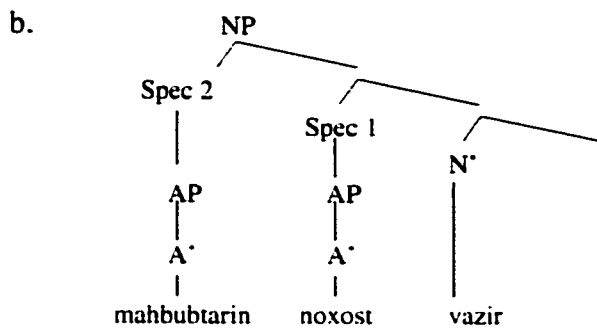

Adopting (31b) and (32b) as the relevant trees for (31a) and (32a) would necessitate a revision of the LCA principle “one Spec for one head”. Problems such as this have been the main motivation for the possibility of more than one Spec for one head as proposed in Chomsky (1995) and Cinque (1996). However, as Cinque (1996) states, if there is strong evidence that the one specifier /one head theory is empirically adequate, it will be more restrictive and hence should be preferred. The principle “one Spec for one head” is in fact viable for the Persian structures in (31) and (32). Following Bateni (1969: p.140), I argue that the elements which we considered as Spec1 in (31) and (32) do not occupy another specifier position in those structures. Instead, each of them is a part of a compound selected from the lexicon together with N’ as one lexical item. That is to say, from a morphological perspective, both *qahve xāne* “coffee shop” in (31), and *noxost vazir* “prime minister” in (32) have been selected as one item from the lexicon and constitute the head of the phrase which projects NP. This line of argumentation brings about the configurations in (33) as the alternatives to (31b) and (32b):

(33) a.

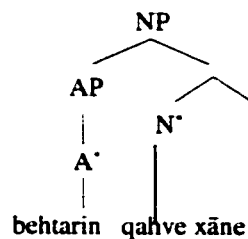

b.

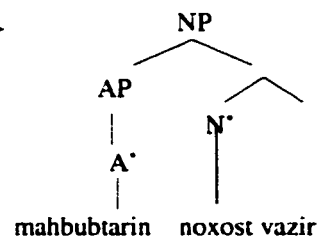

Interestingly, the compound *noxost vazir* “prime minister” corresponds to a simple N in some languages, e.g. “chancellor” in some countries like Germany, or “premier” when it refers to the prime ministers of provinces in Canada.

To resume, the structure that I have proposed thus far for DPs (down to N<sup>o</sup>) in Contemporary Colloquial Persian is shown in (34):

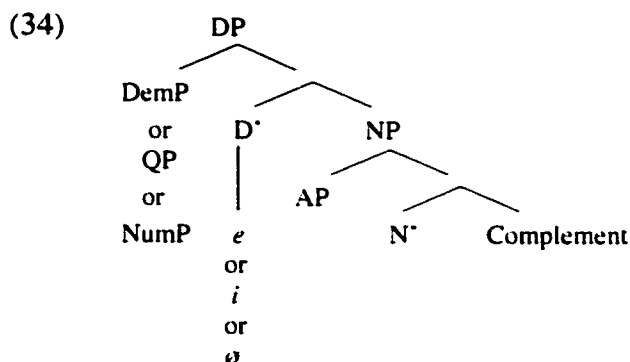

In the next part, I discuss the complements of N<sup>o</sup>.

### 3.4 The Order of Post-N<sup>o</sup> Modifiers: Complements

The theoretical assumptions followed in this research impose only one complement for a head in a phrase. Although in the structure of Persian nominal phrases, modifiers of the N<sup>o</sup> which follow it can be more than one, this restriction is strictly observed. In fact, it is the Ezafe Phrase (EzP) which regulates the occurrence of post-nominal modifiers in a DP. The first point which should be mentioned is the crucial role of the Ezafe morpheme in distinguishing the head N<sup>o</sup> and its complement. The element immediately preceding the first Ezafe morpheme in a DP is the N<sup>o</sup>, head of NP, which, in turn, we analyzed as the complement of D', head of DP. Thus, in (35), *pesar* “boy” is N<sup>o</sup>:

- (35) in pesar-e xub  
*this boy Ez good*  
 "this good boy"

In Chapter 2, I analyzed EzP as a functional phrasal category headed by the Ezafe morpheme /e/ or /ye/ or /ø / which can have a DP, AP or PP complement. This EzP functions as the complement of any N' or A'. In Persian DPs, EzP can be repeated several times resulting in a DP with an N' with several modifiers, all of them to the right of the head N'. My analysis of EzP prevents the occurrence of more than a complement at a time, in a manner in which the head of each DP/NP, AP, or PP, complements of Ez' selects its own complement to the right. The number of the complements, their phrasal types, and their order within the DP are illustrated by the structural representation (36a) of the phrase in (36b):

- (36) a. N' +  $\left[ \begin{array}{c} \text{NP} \\ \text{AP} \end{array} \right] + \text{AP} + \text{NP} + \text{PP} + \left[ \begin{array}{c} \text{NP (Pronoun)} \\ \text{CLP} \end{array} \right]$

- b. ostād - e dānešgāh-e montaxab-e in kešvar darzamineye tārix - aš  
*professor Ez university Ez chosen Ez this country in history - its*  
 "this country's chosen university professor in its history"

Considering the peculiarities of the EzP, it is possible to have more complements for N' without deviating from the principles of the LCA. To demonstrate how my proposal works, I start with noun phrases whose head N' has only one complement. No. (37) illustrates a case where N' is followed by another noun in a DP:

- (37) a. behtarin ostād -e dānešgāh  
*best professor Ez university*  
 "the best university professor"

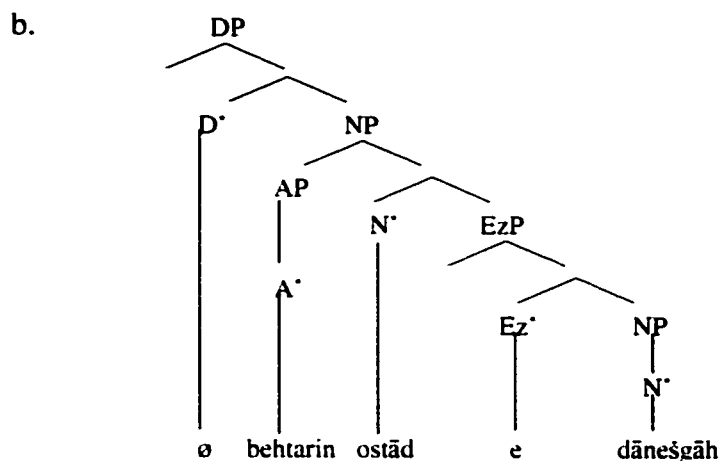

As (37b) shows, the N' *ostād* “professor” subcategorizes for its complement EzP to the right. EzP headed by Ez' *e*, in turn, subcategorizes for its complement which is an NP headed by N' *dānešgāh* “university”. The result of this process is shown in the DP (37b) which is the representation of (37a). In (37), the N' *ostād* “professor” does not overtly move to the null D', but agrees with it. It seems that the A' *behtarin* “best” in the specifier position of the NP prevents the overt Move of the N', and causes it to covertly agree with the D'.

Before analyzing cases where N' is modified by an adjective that follows, I recall that in Persian, attributive adjectives occur both pre- or post-nominally. Actually, it is not the class of adjective, but rather the EzP that governs the distinction between these two occurrences of adjectives. The adjective that follows N' must necessarily appear in an EzP, complement of N'; but the pre-nominal adjective occurs in Spec NP as discussed before. As mentioned earlier, a limited number of adjectives, including superlatives, ordinal numbers and some adjectives like *yegāne* “unique” fill Spec NP. Even these pre-nominal adjectives can occur post-nominally, if they appear in an EzP. This fact is shown in (38) where in

(38a), a superlative precedes N\*, but in (38b), the same superlative appears post-nominally in an EzP:

- (38) a. *āxarin šām*  
*last dinner*  
 “the last dinner”
- b. *šām - e āxarin*  
*dinner Ez last*  
 “the last dinner”

Although (38a) and (38b) carry the same meaning and are both grammatical, the pre-nominal occurrence of superlatives (and ordinal numbers) is more common. Two distinguishing criteria for pre-nominal and post-nominal adjectives in Persian are: 1) pre-nominal adjectives are superlatives, ordinal numbers, and two adjectives meaning “unique” (i.e. *yegāne* and *yektā*); and 2) regardless of the class they belong to, all Persian adjectives can appear postnominally, a feature which differentiates this language from some other languages. In Italian, for example, referential (or thematic) adjectives show a different distribution from modal (or intentional) adjectives as shown in (39):

- (39) a. *l’invasione italiana dell’Albania* (thematic)  
*the invasion Italian of-Albania*  
 “the Italian invasion of Albania”
- b. *il pover’uomo* (modal)  
*the poor man*  
 “the poor man”

While, in Persian, all adjectives, even those which appear pre-nominally, may appear post-nominally in an EzP.

I discussed earlier that the head-to head movement in DPs applies in Persian, and this behavior together with the characteristics of D\* elaborated in section 3.1 justify the DP Hypothesis for this language. I have shown that an NP is selected as the complement of D\* to its right and then N\*-to-D\* movement adjoins the head of the NP to the head of the DP. This analysis brings about satisfactory results up to the point that there is only one modifier

for N' to its right. In chapter 2, in the discussion of the EzP, I argued that this functional category regulates the occurrence of more modifiers for the same head. There, I suggested that a movement analysis is necessary to retain the selectional properties of N' with its different complements. To do so, I proposed that N' is generated in the Spec of the lowest EzP as the head of an NP. Then, N' moves higher up, not as a head but accompanying the specifier and the complement of the NP of which it is the head. This move takes the N' higher in the DP until it ends up in the Spec of the highest EzP and will be realized as the head of the NP occupying the specifier position of the highest EzP<sup>4</sup>.

A question arises here: How can we justify distinct underlying structures for identical thematic relations? In other words, doesn't this analysis for the base generation of N' contradict the Uniformity of Theta Assignment Hypothesis (UTAH) of Baker (1988)? As Larson (1990) points out no current analysis holds to the strict form of UTAH-including that of Baker (1988), the author of this hypothesis. In the wake of this departure from strict

<sup>4</sup> The analysis proposed here for DPs is very similar to the proposal for VPs by Larson (1988,1990). Larson analyzes post-complement adjuncts as phrases that are themselves in a complement position with respect to some head, as shown in (2), the representation of the sentence in (1):

(1) John blamed the accident on Max.

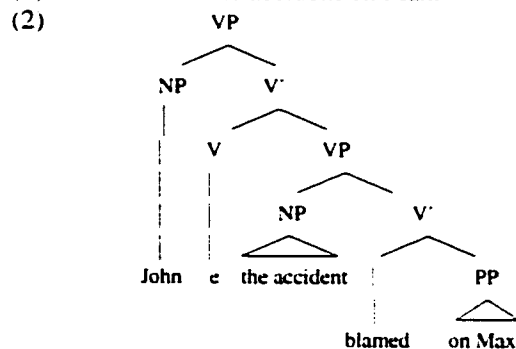

Larson's analysis indicates that "the accident" and "on Max" cannot both be complements (i.e. sisters) of the verb "blame". His line of argumentation is followed in the LCA which does not permit a head to have more than one complement on the grounds that the two complements would asymmetrically c-command subparts of each other and produce a violation of antisymmetry. In the LCA this argumentation is applied to all phrasal categories.

UTAH, Larson (1988) presents two different analyses for the same Object in (40a) and (40b):

(40)

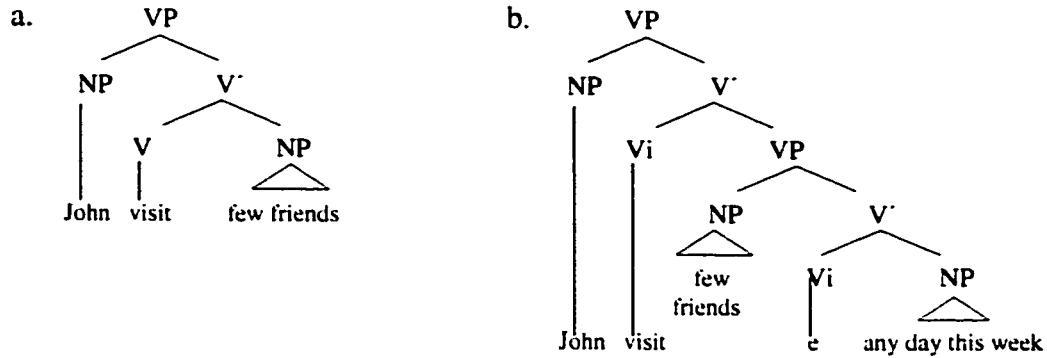

In (40b), the object “few friends” is realized structurally as specifier of V'; in (40a), it is realized as a complement of V. Such a departure from strict UTAH will occur whenever an optional argument is realized: a complement in one structure will be realized as a specifier in the other, despite bearing the same thematic relation in both. Larson's treatment of the same object in two different structures is in a way similar to my analysis of the base generation of N' in a DP. In one case N' heads the NP, complement of D', but in the other case, it originates in the Spec of the lowest EzP.

The analysis proposed for the base generation of N' in these two positions is theoretically justified as discussed before, and is empirically supported by the internal structure of Persian DPs. However, there is an alternative with only one structure for a DP, regardless of the number of post-N' complements. This analysis, too, follows the theoretical foundation of this research, and is to some extent, similar to the second analysis proposed for DPs with multi post-N' complements. To see how this alternative might work, notice (41) in which the head of the NP has only one post-N' complement:

- (41) a. *divār-e ċin*  
 wall-Ez China  
 "China's Wall"

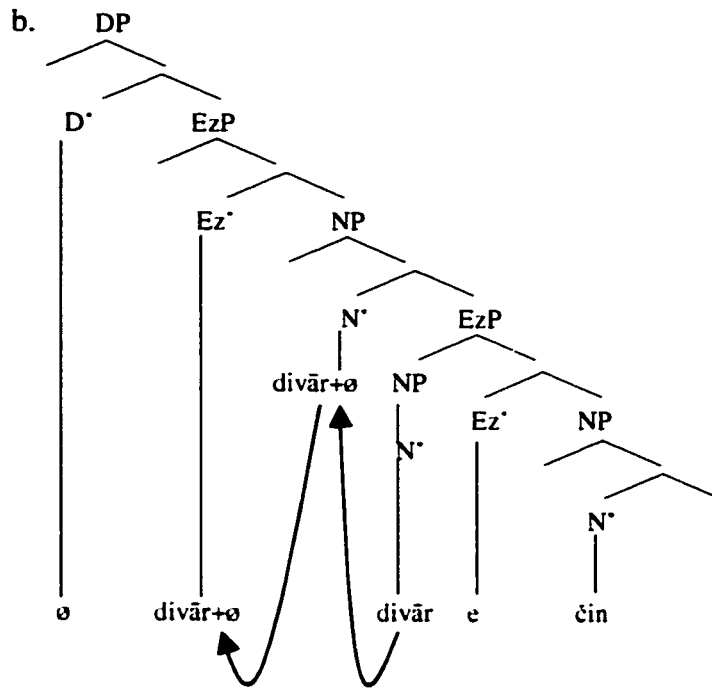

As (41b) shows, the N' *divār* "wall" originates in the Spec of the lowest EzP as the head of an NP. Then, head-to-head movement raises it to N', head of the NP, and adjoins it to the left. In the last stage, the same head adjoins to the highest Ez' which is a null morpheme. The same analysis applies to DPs with multi post-N' complements as shown in (42), in which *divār* "wall" is modified by the N' *ċin* "China" and the A' *bozorg* "great". As illustrated in (42b), the N' *divār* "wall" originates in the Spec of the lowest EzP, and raises to the higher Spec EzP, and then is realized as the N' *divār* "wall". Then, head-to-head movement raises it to N' and then to Ez' and the actual order of the DP is realized.

- (42) a. *divār-e bozorg-e ċin*  
 wall-Ez great-Ez China  
 "The Great Wall of China."

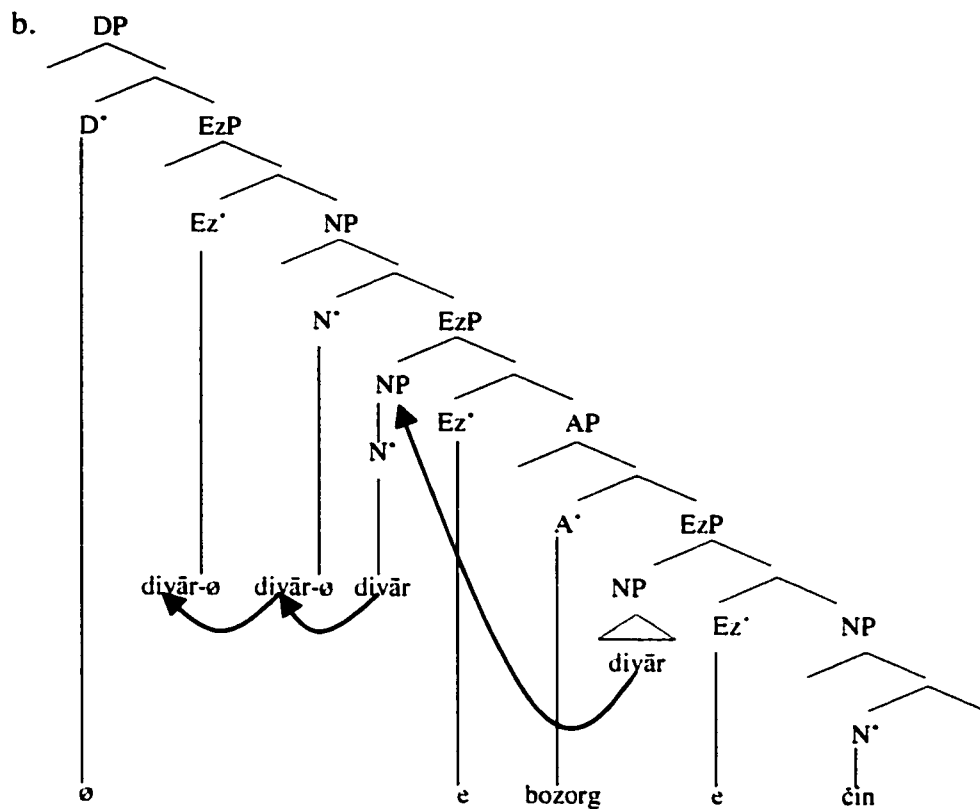

This analysis makes a false prediction. It predicts that in (37b), *ostād* “professor” should be able to skip *behtarīn* “best”, and land in  $D^*$ , which is not possible. Thus, a stipulation is needed to the effect that when the NP contains a specifier that is filled,  $N^*$  cannot raise past that Spec, as discussed above.

Now, in the light of the emphasis on the applicability of the DP Hypothesis for all kinds of Persian nominal constructions, and the generation of  $N^*$  in the Spec of the lowest EzP in more complex DPs, I turn to (43) in which the  $N^*$  *ostād* “professor” is modified by an adjective before being modified by a noun:

- (43) a. *behtarīn ostād – e montaxab – e dānešgāh*  
*best professor-Ez chosen-Ez university*  
 “the best chosen university professor”

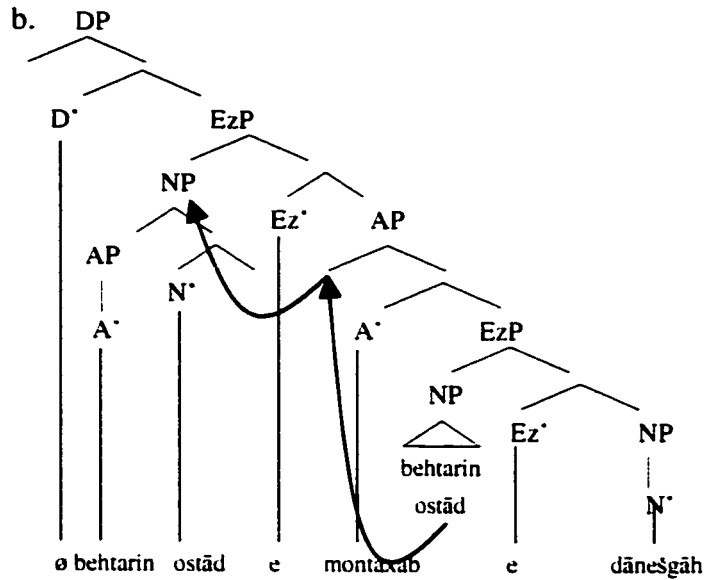

In (43), the N' *ostād* "professor" is modified by two post-N' complements: (a) the adjective *montaxab* "chosen", and (b) the noun *dānešgāh* "university". These two modifiers head an AP and an NP, respectively. In my analysis displayed in (43b), the N' *ostād* "professor" originates in the specifier position of the lower EzP as the head of an NP whose specifier is *behtarin* "best". The local relationship between the specifier of the EzP, *behtarin ostād* "best professor" and its complement *dānešgāh* "university" retains the selectional properties of these two constituents. Then, the NP in Spec EzP moves higher up, crossing Spec AP. The landing site of that NP will be the specifier position of the higher EzP. This Move respects the Minimal Link Condition (MLC). Due to the function of the EzP, which is to add more complements to the head N', the specifier position of this phrase will be the appropriate landing site for movement. The NP will first move to the Spec of AP, and subsequently to the Spec of EzP, which preserves the necessary locality relation under the MLC. This movement makes the semantic relationship between the N' *ostād* "professor" and its other modifier, the adjective *montaxab* "chosen" possible. Having established the

relevant selectional properties, the moved maximal projection in the Spec EzP, is an NP, headed by the N', *ostād* "professor" with the AP *behtarin* "best" in its Spec. This process produces the PF realization of the DP in (43a).

The movement analysis elaborated in this part, not only helps retaining semantic relationship between N' and its different modifiers, but also provides two analyses for cases like (44) where two interpretations are possible for a single DP:

- (44) a. *behtarin ostād-e dānešgāh-e montaxab*  
*best professor-Ez university-Ez chosen*  
 b. "the best chosen university professor"  
 c. "the best professor of the chosen university"

As (44 b, c) show, in the first reading of (44a), *montaxab* "chosen" is the modifier of *ostād-e dānešgāh* "university professor" and in the second reading, it is the modifier of *dānešgāh* "university". In order to obtain the interpretation in (44b) a movement analysis is necessary, because both *dānešgāh* "university" and *montaxab* "chosen" are the modifiers of the N' *ostād* "professor", and this movement retains the selectional properties of N' and its complements as displayed in (45):

(45)

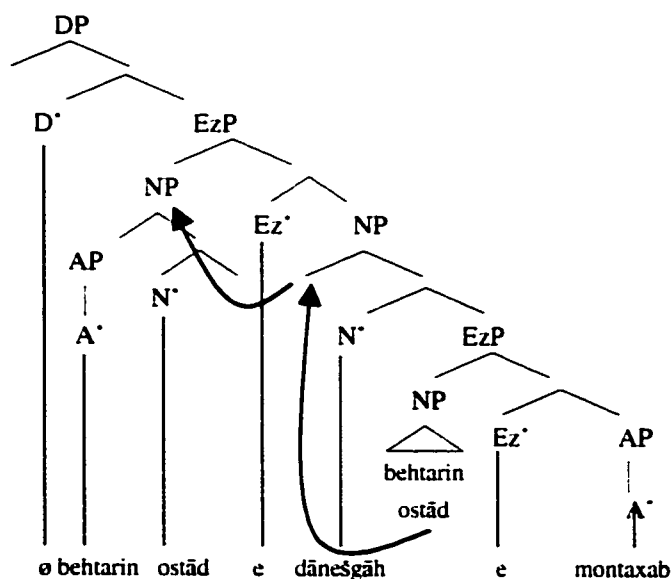

The movement is not applied in (44c), because in this reading of the DP, the adjective *montaxab* “chosen” is not the modifier of the N’ *ostād* “professor” but the modifier of the lower N’ *dānešgāh* “university” as shown in (46):

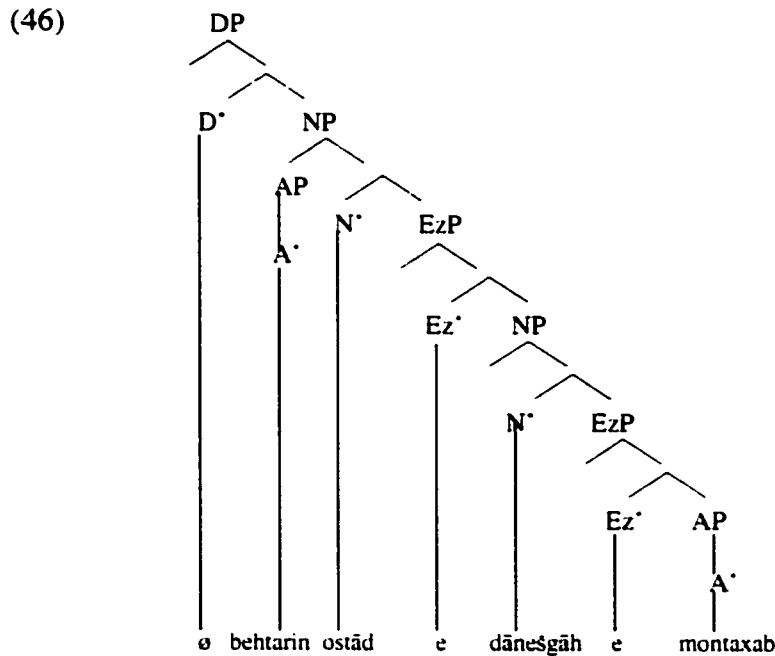

This tree illustrates the relevant semantic relations between the elements of the DP: *ostād* “professor” is modified by *dānešgāh* “university”, and *dānešgāh* “university” is modified by *montaxab* “chosen”. As (46) displays, this reading of the DP in (44) does not necessitate a movement analysis, contrary to (45) in which the movement analysis brought about the PF realization of the DP.

Before investigating other post-N’ elements in Persian DPs, I should recall that assigning a phrasal status to each element following N’ gives a consistency to the universal Spec-Head-Complement configuration adopted in this research, and is robustly supported by examples such as (47):

- (47) a. *ostād-e in dānešgāh-e xub*  
*professor-Ez this university-Ez good*  
 “the professor of this good university”

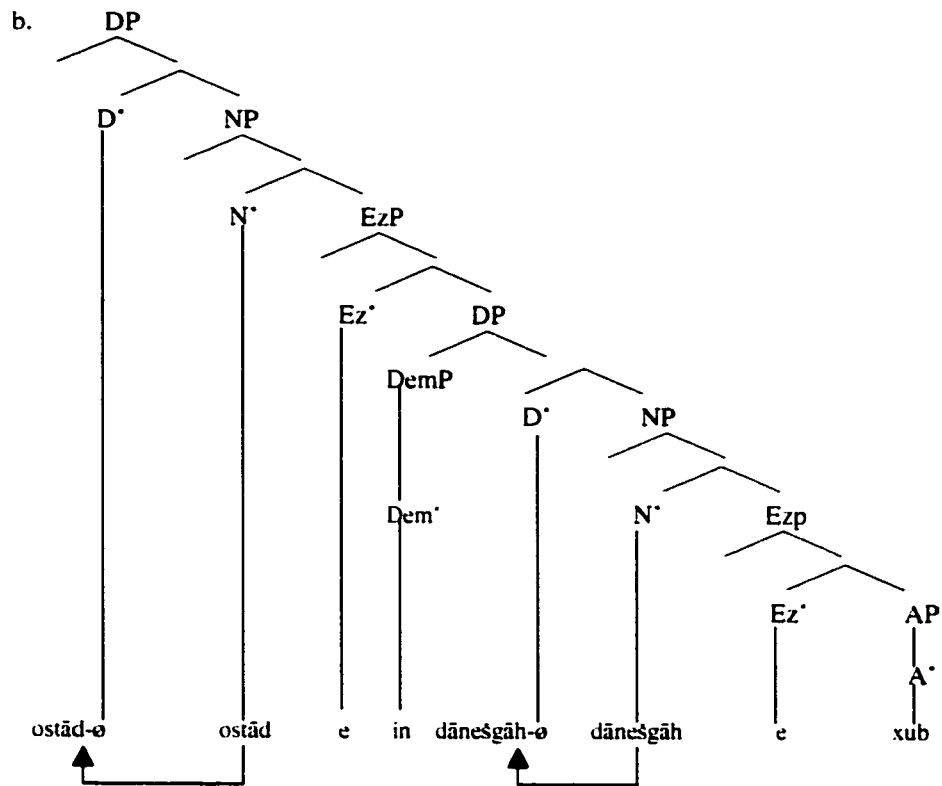

In (47b), the higher EzP which is the complement of N', is headed by Ez' *e*, which, in turn, has another DP as its complement. This DP has *in* "this" in its Spec, its head D' is  $\emptyset$ , and has an NP in its complement position. This observation implies that although post-N' elements are normally one-membered constituents, they are heads of APs or DPs which modify the N' in an EzP configuration. In other words, they are maximal projections whose specifier positions can be filled as shown in (47). This observation supports Samiian's (1983) claim that post-N' complements are actually maximal projections, and rules out Ghomeshi's (1996, 1997b) account that linked elements are attached by head adjunction, a conclusion which is in favor of the LCA which does not accept head adjunction to the right.

Up until now, I have investigated adjectives and nouns modifying N' in complement position. It was shown that they appear as heads of APs and NPs realized in EzPs. There is yet another phrasal category which can be the complement of N': prepositional phrases.

Similar to NPs and APs, PPs can appear as the complements of  $Ez'$ , head of  $EzP$ , which, in turn, is the complement of  $N'$ , as shown in (48):

- (48) a. violonzan-e ruye bām  
*fiddler Ez on roof*  
 "Fiddler on the roof"

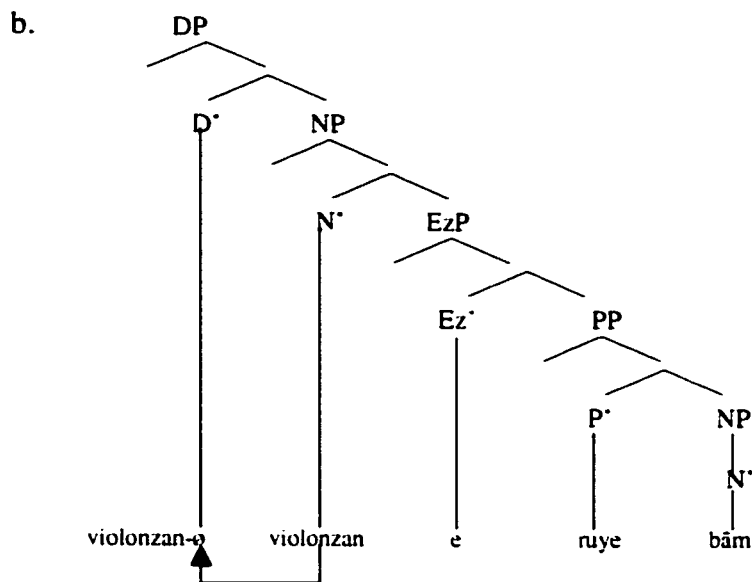

In (48), the PP *ruye bām* "on the roof" appears as the complement of  $Ez'$  to the right, which, in turn, is the head of  $EzP$ , complement of  $N'$ . When there is another modifier for  $N'$ , the latter precedes the PP, that is, the PP complement follows the AP and DP complements of  $N'$ . As discussed earlier, when there is more than one post- $N'$  complement in a DP,  $N'$  originates in the specifier position of the lowest  $EzP$  and then moves up and lands in the specifier position of the highest  $EzP$ . In this case,  $D'$  subcategorizes for an  $EzP$  as its complement, and it is the specifier position of this  $EzP$  that hosts  $N'$  as (49) illustrates:

- (49) a. violonzan-e mašhur-e ruye bām  
*fiddler Ez well-known-Ez on roof*  
 "the well-known fiddler on the roof"

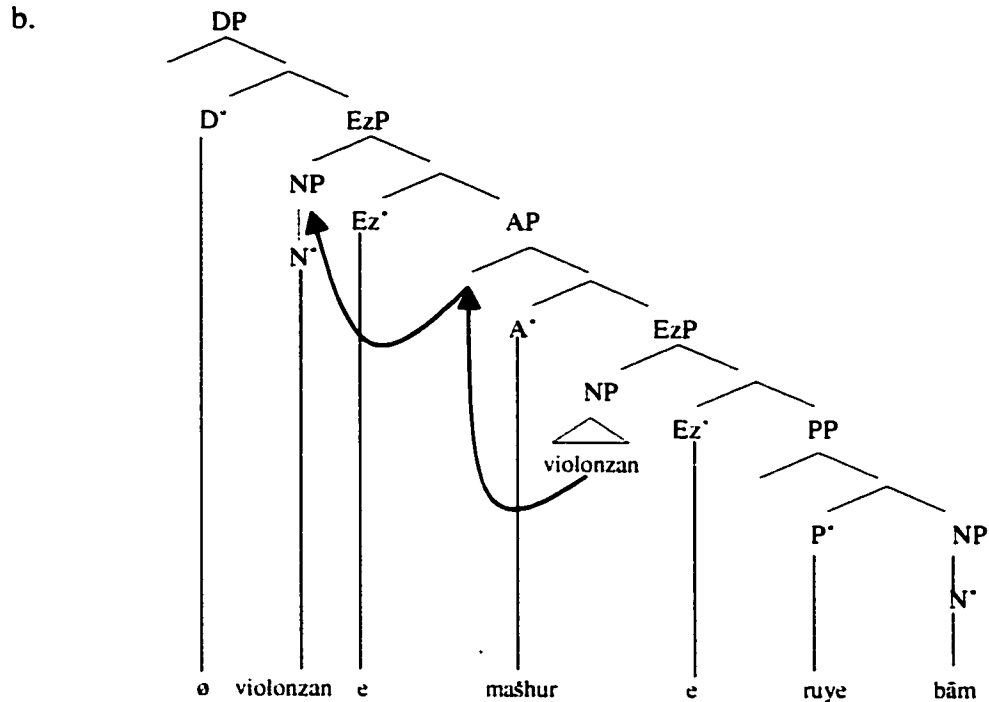

As shown in (49b), the N\* *violonzan* “fiddler” originates as the head of an NP in the specifier position of the lower EzP, and establishes the semantic relationship with the PP *ruye bām* “on the roof”. Then, this N\* together with other constituents of the NP of which it is the head, move up and land in the specifier position of the higher EzP and are realized as N\*. This process produces the PF realization of the DP in (49a).

The analysis proposed for the occurrence of the complements of N\* in this research explains the manner in which several post-N\* complements may appear in DP. As discussed, all the complements are selected by the heads to their right. The principle of repeatability of EzPs allows the addition of more complements to the head of NP. Theoretically, this addition can continue as long as there are more modifiers for N\* in the post-head position. There is only one complement whose occurrence denotes the closing of the DP. No. (50) illustrates this kind of complement:

- (50) a. *xeiremaqdam-e garm-e u*  
*welcome Ez warm-Ez he*  
 "his warm welcome"

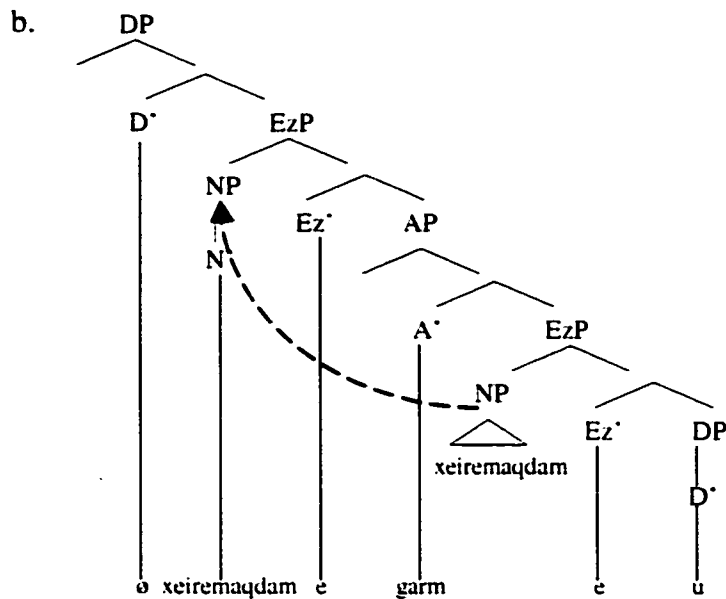

In (50a), two modifiers follow the N' *xeiremaqdam* "welcome", the A' *garm* "warm" and the pronoun *u* "he". As discussed before, for cases like this where more than one complement modifies the N', the head noun originates as the head of an NP in the specifier position of the lowest EzP and then this NP moves up and lands in the specifier position of the highest EzP and is realized as the N'. This movement analysis retains the selectional properties of the head N' and its modifiers and yields the PF realization of the DP in (50a). As mentioned, because N' has more than one modifier, D' selects an EzP as its complement, contrary to a nominal construction where there is one post-N' complement in which D' subcategorizes for an NP to its right (compare 50b with 48b and 37b). When the lowest DP is realized as a pronoun, no additional complement can be added to the DP. In this case, the lowest EzP in (50) can be cliticized, yielding (51):

- (51) a. *xeiremaqdam-e garm-eš*  
*welcome – Ez warm-CL*  
 "his warm welcome"

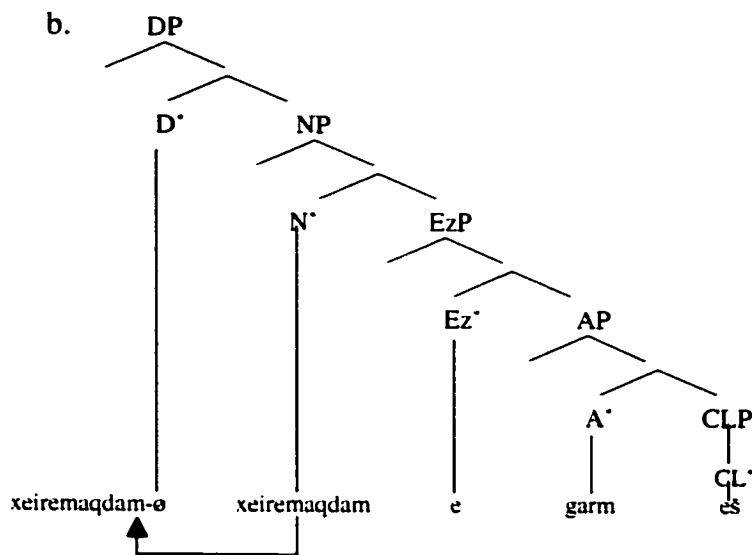

In (51b), A\* selects a Clitic Phrase (CLP) as its complement to the right. Similar to (50), in (51) the lowest complement, i.e. CLP, closes the DP.

### 3.5 Summary and Conclusions

To summarize this extensive investigation, I have argued for the following theoretical and structural analyses of nominal phrases in Contemporary Colloquial Persian:

- 1) nominal phrases in Contemporary Colloquial Persian should be analyzed as DPs;
- 2) all DPs appear in a Spec-Head-Complement configuration;
- 3) regardless of the number of modifiers in a DP, all of them appear in such a way that for each head, there is one Spec to the left and one complement to the right;
- 4) EzP regulates the positioning of relatively unlimited number of post-N\* modifiers in a DP;
- 5) elements appearing in Spec DP and Spec NP constitute a closed class of items, contrary to those which are subcategorized for as the complements of N\* to its right; and

- 6) these results confirm the validity of LCA assumptions, and give an absolute head-initial status to Persian DPs.

## **Chapter 4**

### **Persian Verb Phrases**

In this chapter, the structure of the verb phrase is investigated, with particular attention to the order of constituents within the VP. In the introduction to this chapter in 4.1, the importance of the analysis of the VP and its critical role in determining the problem of directionality in this language is surveyed. Then, in 4.2, due to the close dependence of sentential word order and VP internal word order, I review some previous studies of Persian sentence word order; and later, in 4.3, the literature review is analyzed. Following this, in 4.4, I present arguments to support a head-initial analysis of Persian verb phrases. In addition to a methodological argument which rules out a dual directionality for the VP, I present four empirical arguments supporting a head-initial analysis for Persian VPs. First, I show that for NP complements both SOV and SVO orders are possible in unmarked sentences in Persian. This is in contrast to CP complements which must occur post-verbally, implying a VO order. Further to this, I note that clitic placement also supports a head-initial analysis for Persian, as does the position of adverbs relative to V<sup>\*</sup> and its complement. In 4.5, Dative Constructions in Persian are investigated. The last section of this chapter summarizes it and presents the conclusions.

#### **4.1 Introduction**

Among different phrasal categories of any language, verb phrases are of special importance due to some peculiarities distinguishing them from other maximal projections. First, the

VP-Internal Subject Hypothesis adopted in this research assumes that the Subject originates in the VP. Considering the fact that the two other main constituents of a sentence, i.e. Verb and Object, are two major building blocks of a VP, it is evident that the three pillars of a sentence originate in the VP. In other words, a predicate and its external and internal arguments are generated in the verb phrase. The second feature of a VP that underscores its importance is its relation to the functional category IP which is directly founded on the lexical category VP. Adopting a minimalist analysis (Chomsky 1995), IP is split into three functional phrases AgrsP, TP and AgroP, and is the checking domain for the elements of the VP. This relationship is responsible for the second special characteristic of VPs. These features lead us to a very important outcome regarding the problem of word order. That is to say, the analysis of the VP portrays the basic word order of a language, and later, the process of feature checking determines the actual possible word order(s). In addition to these two characteristics of VPs which are general to all languages, another feature specific to Persian VPs gives a much more specific situation to VPs in this language and it is the position of the head of the VP relative to its complement. In chapter 1 (p.21-3), I noted that there was general agreement that all Persian categories are head-initial except VPs, which are normally considered to be head-final. However, there are instances where V' selects its complement to the right, and these undermine this generalization and cast doubt on its validity. In order to solve this problem, the supporters of a head-final VP for Persian argue that cases where V' selects its complement to the right are instances of Topicalization (Karimi 1989). However, there is no consensus among linguists considering VO strings as marked orders, as shown in Marashi (1970: p.37), Meshkat al-Dini (1998) and Moinzadeh (1999). Considering these facts which indicate the simultaneous occurrence of VO and OV

orders in Persian VPs, if one can argue for at least one piece of evidence preferring one order over the other one, this duality in the directionality of subcategorization process in VPs will be solved in favor of a consistent directionality criterion for this maximal projection. That is why the analysis of VPs appears to be so important in the analysis of Persian phrase structure. In this chapter, I argue for a head-initial analysis of Persian VPs and present both methodological and empirical evidence supporting this claim. The argumentation presented parallels Persian VPs with other XPs of the language and gives a consistent head-initial configuration to all phrasal categories. This finding has an important outcome for syntactic theory in supporting the main claim of the LCA which states that Spec-Head-Complement is a component of UG.

Due to the importance of the relative positioning of the head V' and its complement Object and its specifier Subject in VPs, and its relation to the order of these constituents in IPs, in the next section, I present a review of previous works on Persian sentential word order.

## **4.2 Review of Previous Works on Persian Sentence Word Order**

Most traditional grammarians as well as modern linguists working on Persian have made some contribution to the study of word order. In this section, I will review the literature on this subject.

Phillott's "Higher Persian Grammar", published in 1919, was probably the first grammar of Persian which tried to account for the language on its own terms. Phillott's grammar is quite rich and detailed and it was the first grammar to include some notes on spoken Persian and make the distinction between colloquial and formal Persian. However,

as a prominent traditional grammarian, he confuses Classical Persian and Contemporary Persian, and fails to reveal any significant information about word order.

Foroughy (1944) considers Persian an SOV language and gives No. (1) as the word order for Persian:

- (1) S-Attributive – DO – IO –V

Jazayery & Paper (1961) state that SOV is the dominant word order, and that there is an OSV order which is not very common.

Boyle (1966) also states that Persian is an SOV language. He further suggests some exceptions with respect to the final position of the verb in this language such as the placement of adverbial phrases after the verb as shown in (2):

- (2) barādar-am diruz raft orupā  
*brother-my yesterday went Europe*  
"My brother went to Europe yesterday."

However, he considers that exceptions like (2) do not contradict the assumption of an SOV order for Persian.

Moyne (1970), Khanlari (1976), Vazinpoor (1977), and Farrokhpey (1979) share a similar idea and consider Persian as a verb-final language with an SOV word order.

Marashi (1970), using the framework of Chomsky (1965), is the only study which classifies Persian as a verb-initial language. On the basis of Ross's *Gapping* and scrambling rules, Marashi argues for an SVO order.

Before introducing Marashi's analysis, a review of the notion *Gapping* will be of help. Notice the following example from Ross (1967):

- (3) I ate fish, Bill ate rice, and Harry ate roast beef.

The English rule of *Gapping* converts structures underlying such sentences as (3) into those underlying the corresponding sentences as in (4):

(4) I ate fish, Bill rice, and Harry roast beef.

This rule operates to delete indefinitely many occurrences of a repeated main verb in a conjoined structure. Note that *Gapping* operates only forward in English; that is, in *n* conjoined sentences, it is the leftmost occurrence of the identical main verb that causes the *n-1* following occurrences to be deleted. Applying backward *Gapping* in the English sentence in (3) results in an ungrammatical structure as shown in (5):

\*(5) I fish, Bill rice, and Harry ate roast beef.

Following Ross (1967), Marashi states that the rule of *Gapping* operates forward (SVO+SO) in verb-initial languages such as English, while in verb-final languages like Japanese, this rule operates in the opposite direction. Thus, the result of the application of *Gapping* on two verb-final Persian sentences in (6a) will be the sentence in (6b)<sup>1</sup>:

(6) a. man ostād-e tārix rā mišenās-am va šomā ostād-e fizik rā mišenās-id  
*I professor Ez history rā know-I and you professor Ez physics rā know-you*  
“I know the history professor, and you know the physics professor.”

b. man ostād-e tārix va šomā ostād-e fizik rā mišenās-id  
*I professor Ez history and you professor Ez physics rā know-you*  
“I know the history professor, and you the physics professor.”

In other words “SOV + SOV → SO + SOV”. The outcome of *Gapping* is a grammatical sentence; but in addition to *Gapping*, Marashi assumes that a rule of scrambling is obligatory. In his analysis, he makes use of both *Gapping* and a scrambling rule, and argues that by assuming an SOV order for Persian sentences in deep structure, we will arrive at two different outputs, employing backward and forward *Gapping*:

---

<sup>1</sup> Example is from Marashi (1970), p. 36-7.

(7) If SOV in Deep Structure

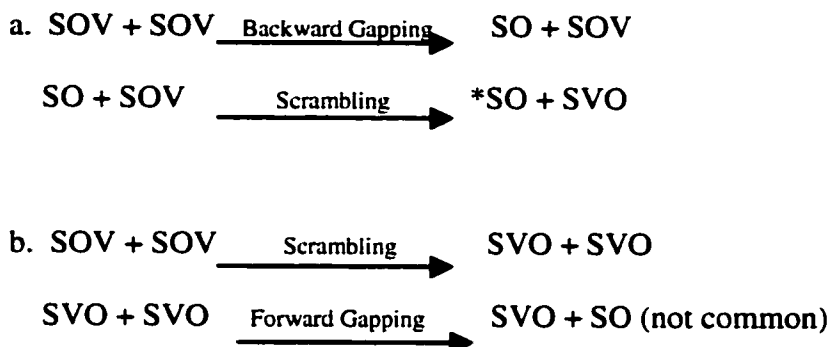

I discussed in (6) that the use of backward *Gapping* in head-final sentences produces well-formed strings. But when the scrambling rule which Marashi supposes to be obligatory operates, this result will be ruled out as (7a) indicates. This is instantiated by the example in (8):

\* (8) S O \_\_\_\_\_ + S V \_\_\_\_\_ O \_\_\_\_\_  
man ostād-e tārix va šomā mišenās-id ostād-e fizik  
*I professor Ez history and you know-you professor Ez physics*  
"I know the history professor, and you the physics professor."

In (7b), at first, the scrambling rule changes the combination of two head-final sentences to two head-initial sentences, and then forward *Gapping* operates and produces SVO + SO which is not common. Given the underlying SVO order for Persian, however, Marashi arrives at the following well-formed outputs:

(9) If SVO in Deep Structure

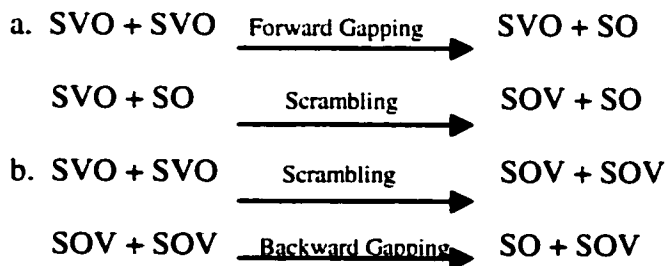

According to him, both outputs in (9) correspond to well-formed Persian sentences. The following examples clarify this process:

(10) If SVO in Deep Structure

- a. āraš xord sib-ro, va niku xord ālu-ro Forward Gapping →  
*Arash ate apple-rā, and Nikoo ate plum-rā*  
 S V O ,and S V O
- āraš xord sib-ro, va niku ālu-ro  
 S V O , and S O
- a'. āraš xord sib-ro, va niku ālu-ro Scrambling → āraš sib-ro xord  
 S V O , and S O S O V,  
 va niku ālu-ro.  
 and S O
- b. āraš xord sib-ro, va niku xord ālu-ro Scrambling → āraš sib-ro  
 S V O , and S V O S O
- xord, va niku ālu-ro xord.  
 V , and S O V
- b'. āraš sib-ro xord, va niku ālu-ro xord Backward Gapping →  
 S O V ,and S O V
- āraš sib-ro, va niku ālu-ro xord.  
 S O , and S O V  
 "Arash ate the apple, and Nikoo ate the plum."

(10a, a') exemplify the process illustrated in (9a). In the first step, forward *Gapping* operates on two SVO sentences, producing the string (SVO + SO). Then, the obligatory rule of scrambling operates and the outcome will be (SOV + SO) which is well-formed. In (10b, b'), at first the rule of scrambling operates on two SVO strings and produces the string (SOV + SOV). Then, *Gapping* operates and produces SO + SOV order which is grammatical in Persian.

Although Marashi's analysis is based on *Gapping*, it is the application of the rule of scrambling which brings about satisfactory results. In addition to *Gapping* and scrambling, he also suggests a Verb-Object Rule which he postulates to be obligatory:



- (14) SOV  $\longrightarrow$  VSO  
 man u-rā did-am  $\longrightarrow$  did-am-eš  
*I he-rā saw-I saw-I-him*  
 "I saw him".

Following Jazayery & Paper (1961), Soheili-Isfahani is the second linguist who proposes more than one word order for Persian.

Kruse (1978) gives some evidence for considering Persian, if not an SVO language, at least anything but SOV. Based on Greenberg's criteria, *Gapping* constructions and diachronic data, she tries to reject an SOV order for Persian and moves towards suggesting an SVO word order for Persian. Applying Greenberg's criteria, she arrives at the following four conclusions, which support her rejection of an SOV order for Persian:

- a. Persian is a prepositional language. Prepositional languages are predominantly either type I (VSO) or type II (SVO). This fact is shown in (15):

- (15) širin ketāb-rā be to dād  
*Shirin book-rā to you gave*  
 "Shirin gave the book to you."

- b. The Persian adjective follows the noun, an order found in type I and II languages, but not in type III (SOV) languages. No. (16) illustrates this point:

- (16) gorbe - ye xub  
*cat Ez good*  
 "the good cat"

- c. Persian is a head-noun/genitive language, a characteristic of type I and II languages, but not of type III languages which are generally genitive/noun. This characteristic of Persian is displayed in (17):

- (17) ketāb - e šomā  
*book Ez you*  
 "your book"

d. Persian questioning correlates with type II languages rather than type III, in that there is an initial question word and subject-verb inversion, as shown in (18):

- (18) a. (āyā) šomā xaste hastid (with initial question word)  
*is it that you tired are*  
"Are you tired?"
- b. kojā budid šomā (subject-verb inversion)  
*where were you*  
"Where were you?"

As evidence for her claim, she reports that McCawley (1970) states that most modern Indic and Iranian languages have all the typological characteristics of verb-initial languages except for actual verb location. Kruse's discussion of the *Gapping* construction is similar to Marashi's which I reviewed earlier. We can conclude from her paper that she argues for a non-SOV order more than an SVO order for Persian.

Aghbar (1981) suggesting an SOV word order states that Persian tolerates a great variety of word orders. In addition to different ordering patterns in which some elements precede the verb, he considers two possible patterns in which some elements follow it:

- (19) a. V – S – DO – Adv  
b. S – V – DO – Adv

Comrie (1981) suggests that in Persian, the basic word order in the clause is SOV. However, following Greenberg's generalizations and Vennemann (1972), he says that Persian is an operand- operator language (i.e., it has prepositions, post-nominal adjectives, relative clauses, and possessors, or in other words it is head-adjunct), but exceptionally it has an OV order.

Dabir-Moghaddam (1982) considers Persian a verb-final language and argues for a rather restricted final position for the verb. He states that "although superficially the

complement clause with or without its head noun may appear post-verbally, the basic SOV order of Persian suggests that all noun phrase complement constructions in Persian should be generated pre-verbally.” He suggests the following formula as the unmarked word order:

- (20)      NP            NP - rā            be/barā-ye NP            V  
               Nominative    Accusative            Subcategorized Prepositional Phrase

Samiiian (1983) postulates an SOV word order and states that the structure of the verb phrase, at least in surface structure, is head-last, and that the head-last order of the verb phrase can be seen both in main and subordinate clauses. Also, she suggests that the ordering of the constituents within the verb phrase is free.

Hashemipour (1989) suggests that colloquial Modern Persian is an SOV language, although there are noteworthy variations in word order. In addition, although VPs are head-final, other phrasal categories are head-initial.

Karimi (1989) presents the most comprehensive work on Persian word order. The canonical word order she suggests for the phrasal arguments in Persian sentences is as follows:

- (21)    (S)    (PP)    (O)    V

In this configuration, the verb is in sentence final position and all elements, except for the verb, are optional, since the subject affix is always attached to the verb, and the verbal arguments (direct and indirect objects) can be incorporated as clitic pronouns to the verb, as illustrated in (22):

- (22)    a. Optional S: pro-drop parameter  
               (man) raft-am  
                   I    went - I  
                   "I went."

b. Optional PP: Cliticization of IO

(man) ketāb - ro dād - am - eš  
*I book - rā gave - I - to him*  
"I gave the book to him."

c. Optional O: Cliticization of DO

(man) did - am - eš  
*I saw - I - him*  
"I saw him."

Karimi considers Persian as an SOV language underlyingly. However, she suggests that this configuration is an unmarked order, subject to a number of re-orderings. These re-orderings are summarized as follows:

- a. The direct object followed by *rā* seems to be able to move freely within the verb phrase, as (23)<sup>3</sup> displays:

- (23) I. sāsān pirhan-o barā sepide xarid. (S O PP V)  
*Sasan shirt-rā for Sepide bought*  
"Sasan bought the shirt for Sepide."  
II. sāsān barā sepide pirhan-o xarid. (S PP O V)

- b. The word order in the preverbal position reveals a number of variations with respect to the position of the subject and the verbal arguments, as illustrated in (24):

- (24) I. pirhan sepide xarid (OSV: Topicalization)  
*shirt Sepide bought*  
"Shirts, Sepide bought."  
II. be sāsān hame mixand-and (PP S V: Topicalization)  
*to Sāsān everyone laugh-they*  
"Sasan, everyone laughs at."

- c. Certain phrasal arguments may appear post-verbally, as (25) displays:

- (25) bačče-hā gozāšt-and ketāb-hā-šun-o ru miz (Interrogative: S V O PP)  
*child-PL put-they book-PL-their-rā on table*  
"As for the children, did they put their books on the table?"

---

<sup>3</sup> Examples are from Karimi (1989).

d. The verb may appear in the sentence-initial position followed by the phrasal arguments, as (26) shows:

- (26) xarid sepide ketāb-o barā-t (Interrogative: V S O PP)  
*bought Sepide book-rā for you*  
 “Did Sepide buy the book for you?”

Karimi suggests the canonical unmarked word order for phrasal arguments not sentential arguments, which are generated post-verbally. It is reasonable to conclude that she suggests two unmarked word orders for Persian as follows:

- (27) a. SOV (when Obj is a phrasal argument)  
 b. SVO (when Obj is a sentential argument)

That is, she considers Persian with a mixed structure. Although the complement phrases follow the nominal, prepositional and adjectival heads, the verbal complements precede the head underlyingly.

Mahootian (1993) suggests that Persian is an SOV language, with modifying adjectives and genitives following the head noun. She supposes the same unmarked, underlying word order as Karimi, and considers Persian as a mixed-head language in which the verb phrase is head-final in both main and subordinate clauses, but all other phrasal categories are head-first.

Vahedi (1994) suggests that Persian has the following basic unmarked order:

- (28) a. S      IO      DO V      (when the DO is nonspecific)  
 ali    be āraš    ketāb dād  
*Ali    to Arash    book gave*  
 “Ali gave a book to Arash.”
- b.      S      DO+rā IO      V      (when the DO is specific)  
 ali    ketāb-o    be āraš dād  
*Ali    book-rā    to Arash gave*  
 “Ali gave the book to Arash.”

From these examples, it is clear that he advocates an SOV word order, with two re-orderings for preverbal constituents.

Ghomeshi (1996) follows Greenberg concerning language typology and the position of phrasal categories which follow their heads (preposition, post-nominal adjectives, relative clauses and possessors), and arrives at the conclusion that it is tempting to posit an underlying SVO order for Persian so that it will then fit nicely into the predicted patterns. Unfortunately, there is no evidence whatsoever for this underlying order. On the contrary, positive evidence can be found for SOV order (Ghomeshi 1996: p.5).

Meshkat al-Dini (1998) is the most recent work on Persian syntax which surveys head-complement order in different phrasal categories. Although he concludes that VPs are head-final, he refers to instances of head-initial VPs in Colloquial Persian, such as the following example (Meshkat al-Dini 1998: p.13):

- (29) *nevešt maqāle rā*  
*wrote paper rā*  
"He wrote the paper."

### 4.3 Summary of Literature Review on Persian Word Order

The consensus of previous surveys suggests that SOV is, at least, the *more frequent* word order in Persian sentences. Even Marashi (1970), the unique advocate of an SVO word order, argues for the *basic* word order SVO from which the *more frequent*<sup>4</sup> word order SOV is derived. His argument and the arguments of other works like Jazayery & Paper (1961), Soheili-Isfahani (1976) and Meshkat al-Dini (1998), which suppose the simultaneous

---

<sup>4</sup> The claim that the *dominant* word order or as I call it the *basic* word order is not based on the frequency of the given word order dates back to Jakobson (1961): "The idea of dominance is not based on the more frequent occurrence of a given order."

occurrence of other word orders for Persian, are not that the normal word order is something other than SOV. As a matter of fact, not only in the written form but also in the colloquial register, the more frequent word order displays objects preceding verbs. This fact is observable in both embedded and main clauses. Moinzadeh (1999) reports a quantitative study of the interference of Persian and English in a bilingual community with robust findings regarding Persian word order which is of interest to this research. He shows that in an unmarked situation, 92% of the Persian sentences produced by native speakers had an SOV word order, while only 8% showed an SVO word order. No. (30) illustrates some data from this work in simultaneous discourse in which an SVO order is used:

- (30) a. vaqti mār̄k karde bud-and naqše-ro  
*when mark done were-they map-rā*  
 "When they had marked the map."
- b. tu xiābun nevešte for seil  
*in street written for sale*  
 "In the street, it is written for sale."
- c. minevis-am se sāntimetr  
*write - I three centimeter*  
 "I write three centimeter."
- d. agar pikāp kard loqat-ro, az-aš estefāde mikon-e  
*if pick up did word-rā of - it use does - he*  
 "If he picks up the word, he will use it."

As far as I know, this is the only quantitative survey of Persian word order. The principal findings of this study are: 1) the most frequent word order is SOV, and 2) the SVO word order, while much less frequent than SOV word order, is an acceptable structure in unmarked discourse. The first finding reaffirms the widespread opinion about Persian word order, but the latter one is a turning point in the analysis of word order. It suggests that SVO is a structure parallel to SOV in unmarked Persian sentences. Previous studies, e.g. Karimi

(1989), have treated SVO word order as cases of Topicalization embodying a marked reading. The novelty of Moinzadeh's finding coupled with my intuition as a native speaker of Persian constitute the concrete basis for my theoretical analysis of the basic word order of Persian. That is to say, they are evidence for my discussion of the relative order of V\* and Obj in Persian VPs.

In 4.2, in the review of Marashi's (1970) arguments in favor of an SVO word order for Persian, I showed that he bases his arguments on Ross's *Gapping* and a rule of scrambling. Although his analysis suggests a head-initial SVO order for Persian sentences, a finding which coincides with my claims regarding the directionality of the V\* head and its complement in VPs and consequently in IPs, I do not agree with his reasoning in two respects. First, the rule of scrambling (in No.7 and No.9), and the obligatory Verb-Object Inversion Rule (No.11) are not well motivated, and secondly, I agree with Karimi (1989, 1994) that *Gapping* does not support an SVO analysis but implies an SOV order for this language. In her argumentation, at first, Karimi agrees with Aoun et al. (1987) in that "gapped verbs are not proper governors", and then tests this idea with Persian sentences with SOV and SVO word order, and proposes the generalization in (31):

(31) Gapped Constructions can be used to determine the base position of the verb.

Contrary to Marashi, she concludes that the canonical word order in Persian is SOV.

#### **4.4 On the Base Position of Object Relative to V\* in Persian VPs**

In this section, I present my arguments in favor of a head-initial VP for Persian. In doing so, I argue that methodologically and empirically, Persian verb phrases appear to have an SVO order rather than an SOV order. The V\* underlyingly selects its complement to the right,

and then the process of feature checking is responsible for different PF realizations of the constituents of VP which comprise IP. In 4.4.1, I argue that in the case where both VO and OV orders are possible in a language, it is methodologically preferable to have just one order as the basic word order. Thus, due to the existence of other evidence supporting a VO order, this order should be considered as the underlying word order of Persian VPs. In 4.4.2, I present my four empirical arguments in favor of a head-initial VP. In 4.4.2.1, I argue that both VO and OV orders are used in unmarked Persian discourse. This position which is based on Moinzadeh (1999), is also supported by Meshkat al-Dini (1998). In 4.4.2.2, I discuss that the exclusive post-verbal position of CP arguments implies that V\* subcategorizes for its CP complement to the right. There, I argue that on the basis of consistency, it is more reasonable to suppose that all NP complements, whether in pre- or post-verbal position are similar to CP complements, and are generated to the right of V\*, with the OV order resulting from some kind of movement. In 4.4.2.3, I investigate clitics and argue that their post-verbal occurrence implies a head-initial VP in Persian. Finally, in 4.4.2.4, the occurrence of Adv between V\* and its complement is argued to be another piece of evidence supporting a head-initial analysis of the VP in Persian.

#### **4.4.1 Methodological Argument: Complement Selection of V\***

Earlier, in the study of Persian nominal phrases, we concluded that it can be maintained that the head subcategorizes for its complement to the right. In case of VPs, the V\* head seems to select its complement to either left or right in unmarked situations. Karimi (1989) argues for this type of analysis in which V\* sometimes selects its complement Obj to the right and sometimes to the left. She argues that V\* selects its complement to the left if it is an NP, and selects it to the right if it is a CP. Karimi's claim is correct to the extent that she states that

V\* selects its CP complement to the right. But confining the NP complement to the left of V\* is not compatible with the facts reported in 4.3. The fact that V\* can select its complement on either side, supports the type of dual analysis, shown in (32):

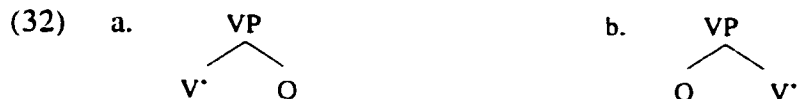

However, (32) is not desirable, because it adds to the complexities of phrase structure. The better solution is to choose one of the alternatives in (32) since a VP is preferably head-initial or head-final, but not both. If a VP is a maximal projection that shares features with other phrasal categories, and all of the other phrasal categories are head-initial, it would seem preferable to extend the head-initial analysis to VPs. In fact, on the basis of four arguments which favor a head-initial VP, I claim that VO order is preferred. This conclusion gives a consistent head-initial configuration to all Persian phrasal categories, a consequence searched at least from the time that the role of head in a phrase was highlighted. Cook & Newson (1996) report that Chomsky (1970) states that "the relative position of heads and complements needs to be specified only once for all the phrases in a given language. Rather than a long list of individual rules specifying the position of the head in each phrase type, a single generalization suffices: heads are last in the phrase or heads are first in the phrase." Then, they conclude, "there are two possibilities for the structure of phrases in human languages: head-left or head-right." (Cook & Newson 1996: p. 14). In the same line, Stowell (1981), while discussing the head parameter, states, "one consequence of adopting the hypothesis of category-neutral theory of the base is that it should be impossible to set this option differently for each category. Thus, a language with a V-final head position for the verb should also have an X-final head position in PP, AP, and

NP.” The foregoing argumentation suggests that a head-initial analysis of Persian VPs is very desirable, and additionally, it is in accordance with the strongest claim of the LCA that there is no directionality parameter and all heads subcategorize for their complement to the right.

#### **4.4.2 Empirical Arguments**

##### **4.4.2.1 Parallel Use of SOV and SVO in Colloquial Persian**

The analysis of the literature on word order in 4.3 concluded with a strong claim about the simultaneous use of SOV and SVO word order in spoken Persian in unmarked situations. This finding which was based on Moinzadeh (1999), Meshkat al-Dini (1998), coupled with my intuition as a native speaker of the language under investigation, changes the direction of the investigation of Persian word order radically. Regardless of the fact that the SOV order is the more *frequent* word order in Persian, positing the status of the SVO word order as unmarked is a crucial step in determining one of these alternative orders as the basic order of V' and its internal argument. Now, we are in a position to choose between the OV and VO order within the VPs. The simplest choice is the more frequent OV order which follows the dominant notion that Persian is an SOV language. Actually, the supporters of an underlying SOV order for Persian have normally taken for granted the more frequent order as the basic order, and have arrived at the conclusion that Persian VPs are head-final. Contrary to this widespread opinion, as Ghomeshi states, “it is tempting to posit an underlying SVO order for Persian so that it will then fit nicely into the predicted patterns” (Ghomeshi 1996: p.5). By predicted patterns, Ghomeshi refers to the criteria that would make this language head-initial in all categories. Although Ghomeshi does not find any evidence for this underlying order, I argue that there is strong evidence supporting head-initial verb phrases and an

underlying SVO word order for Persian. These arguments are presented in the next three subsections. They do not carry the same weight in supporting an SVO order. The argument based on clitics is not as strong as the others. However, the presence of even one argument makes SVO more plausible as the *basic* word order.

#### 4.4.2.2 Post-Verbal Position of CP Arguments as Evidence in favor of VO Word Order

In 4.4.1, it was mentioned that unlike NP internal arguments of V\* which have a dual positioning with either a pre- or post-head realization, when the internal argument of V\* is a CP, it must necessarily follow V\* in a head-initial configuration as shown in (33):

(33) a. āraš midune [CP ke bābā-š dars mixune].  
*Arash knows that dad-his lesson studies*  
 "Arash knows that his dad is studying."

\*b. āraš [CP ke bābāš dars mixune] midune.

In (33a) which is a grammatical sentence, the CP object of V\* follows the head. (33b) is ungrammatical, apparently due to the pre-verbal position of the CP internal argument. Whether the PF position of the clausal argument of V\* is its base position or not has been the subject of many works on Persian syntax. A review of these different analyses will help us better understand the base position of CP complements of the verb and will, in turn, clarify the base position of all V\* complements regardless of their phrasal category. It is noteworthy that all of the works on the base position of clausal arguments of V\* advocate basic SOV word order for Persian.

The proponents of a pre-verbal generation of the clausal argument of V\* basically argue that all complement clauses are embedded in an NP (Soheili-Isfahani 1976; Hajati 1977), or a PP (Dabir-Moghaddam 1982), and end up in the post-verbal position by extraposition. This kind of analysis is ruled out because of two fundamental arguments: 1)

If we suppose that CP complements of V\* are embedded in another phrasal category, it naturally follows that the other category, not the CP, is the complement of V. Thus, in the case where it has been supposed that all complement clauses are embedded in an NP, it is the NP which is selected by V\* as its complement, not the CP. This is shown in (34):

- (34) āraš [NP in-rā [CP ke bābā-š dars mixune]] midune  
*Arash this-rā that dad-his lesson studies knows*  
 “Arash know this fact that his dad is studying.”

Clearly, the NP *in-rā ke bābāš dars mixune* is the internal argument of the V\* *midune* “knows”, and the CP *ke bābāš dars mixune* is selected by the head N\* *in* “this” and therefore, the CP is the complement of the N\* *in* “this”. That is why this NP can follow the head of VP, yielding (35):

- (35) āraš midune [NP in-rā [CP ke bābāš dars mixune]].

This fact is in accordance with our previous finding that NP internal arguments of V\* can both precede the V\* or follow it in PF. Nevertheless, there is another case which needs more elaboration:

- (36) āraš in-rā midune ke bābā-š dars mixune  
*Arash this-rā knows that dad-his lesson studies*  
 “Arash knows this fact that his dad is studying.”

In (36), the NP of (34) and (35) is broken, resulting in the occurrence of V\* between its two parts. Apparently, the V\* *midune* “knows” cannot have two direct objects, due to the general principles governing the selectional properties of verbs and more specifically, due to the LCA restrictions which forbid the simultaneous selection of more than one complement for a head. The logical conclusion will be that the internal argument of the verb has split, resulting in the head of the NP complement preceding the V\*, and the CP, the complement of the N\*, following the V\* in PF. This line of argumentation concludes that cases like (36)

do not exemplify the clausal argument of  $V^*$ ; but, these CPs are the complements of a head noun which have been separated from their heads by some kind of movement.

The analysis I propose for cases like (36) resembles Kayne's (1994) treatment of structures that have frequently been analyzed in terms of rightward movement (extraposition) of the relative clause as shown in (37):

(37) Something just happened that you should know about.

Instead of considering (37) as relative clause extraposition, Kayne treats it as relative clause stranding which recalls Sportiche's (1988) reanalysis of quantifier floating as quantifier stranding. In this analysis, the relative clause is stranded by leftward movement of "something", as (38) illustrates:

(38) Something<sub>i</sub> just happened [[e]<sub>i</sub> that you should know about].

In (38), "something" is generated post-verbally and then moves higher up, leaving the CP relative clause in its base position. The same analysis changes (35) to (36) as the tree in (39) displays:

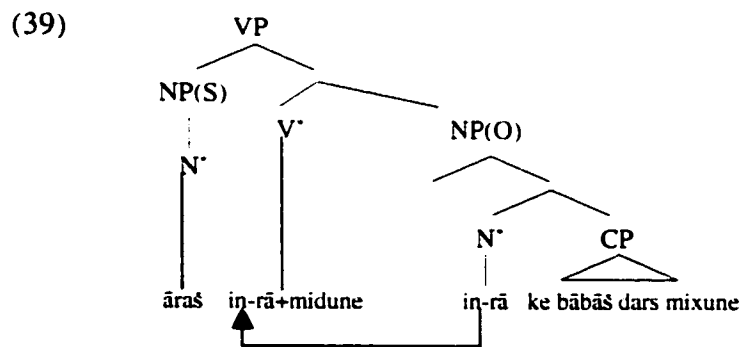

In (39),  $V^*$  subcategorizes for the NP *in-rā ke bābāš dars mixune* "this fact that his dad is studying". The head of this NP is the N' *in-rā* "this" which has selected the CP *ke bābāš dars mixune* as its complement to the right. Head-to-head movement moves *in-rā* "this"

higher up and adjoins it to the left of the V' *midune* "knows", leaving the CP in-situ, and producing the PF realization of the sentence in (36)<sup>5</sup>.

Up until now, in our discussion of the base position of CP complements of V', we concluded that the pre-verbal analysis for these VP internal arguments is ruled out. The natural outcome implies that CP complements are generated post-verbally. Although this inference is convincing enough for positing a head-initial VP when the internal argument is a CP, further syntactic evidence supporting this analysis is found in Tabaian (1974), Karimi (1989) and Darzi (1994). The basic problem facing these linguists stems from their assumption of an underlying SOV for Persian. They must then explain why Obj precedes V' when it is an NP, but follows V' when it is a CP. If Obj is the internal argument of V', why should there be such a difference in complement types relative to the head of VP? In order to overcome this problem, these linguists give a special status to CP complements to support their post-verbal base generation. I suggest the argumentation presented earlier in this subsection regarding the impossibility of pre-verbal generation of a CP complement suffices to prove its post-verbal generation, and there is no need for additional justification. Nevertheless, a review of the main arguments supporting the actual base position of CP in the works of Tabaian (1974), Karimi (1989) and Darzi (1994) will add additional support to my claim that it is generated post-verbally.

The basis of Tabaian's (1974) and Karimi's (1989) analyses is based on the distributional differences between NPs and complement clauses, as illustrated in Karimi's examples in (40):

---

<sup>5</sup> Actually, what is left in the structure in (39) is the process of feature checking which moves the constituents higher up in the functional component. This complementary aspect will be discussed in the analysis of IP.

- (40) a. ānhā porsid - and [<sub>CP</sub> ke mā movaffaq šodi - im]  
*they asked- they that we successful became-we*  
 "They asked if we had succeeded."  
 a'. \*[ke mā movaffaq šodi – im] porside šod
- b. be nazar miād [<sub>CP</sub> ke hame midun-and ke baččehā xaste hastand]  
*to view comes that all know - they that child-PL tired are*  
 "It seems that everybody knows that the children are tired."  
 b'. \*[ke baččehā xaste hastand] be nazar miād ke hame midun-and

Having shown that complement clauses do not have the same distribution as the NP subject of passive (40a, a') or raising predicates (40b, b'), Karimi concludes that they may not be generated pre-verbally. Darzi (1994) convincingly argues that such a conclusion does not necessarily follow from the distributional differences between the two categories. Instead, he presents evidence from the extraction out of the post-verbal clauses to prove that VPs are head-initial when Obj is a CP. To do so, he gives examples of extraposed relative clauses and complement clauses, and shows that extraction is not possible out of the former but possible out of the latter. This argument is illustrated in (41) and (42):

(41) Extraposed Relative Clause

- a. [<sub>IP</sub> [kārgar-ān-i t<sub>i</sub>] šīše-hā rā šekast-and] [<sub>CP</sub> ke u ānhā rā mišenāxt]<sub>i</sub>  
*worker-PL window-PL rā broke-they that he them rā knew*  
 "The workers he knew broke the windows."
- b. \*čekasi<sub>j</sub> [<sub>IP</sub> [kārgar-ān-i t<sub>i</sub>] šīše-hā rā šekast-and][<sub>CP</sub> ke t<sub>j</sub> ānhā rā mišenāxt]<sub>i</sub>  
*who worker-PL window-PL rā broke-they that them rā knew*  
 "Who did the workers who knew broke the windows?"

(42) Complement Clause

- a. to be rezā gofti [<sub>CP</sub> ke ali ma-rā mišenāsad]  
*you to Reza said that Ali I rā knows*  
 "You told Reza that Ali knows me."
- b. ki-o<sub>i</sub> to be rezā gofti [<sub>CP</sub> ke ali t<sub>i</sub> mišenāsad ]  
*who-rā you to Reza said that Ali knows*  
 "Who did you tell Reza that Ali knows?"

After examining relevant examples, he shows that if we suppose a pre-verbal CP complement for V', the difference in extraction possibilities out of extraposed clauses on the one hand and complement clauses on the other could only be explained if complement clauses preserved their L-marked status upon extraposition. However, such an auxiliary assumption may not be maintained as the extraposition analysis of the complement clause fails to account for the c-command relation between the DO and the arguments inside the complement clause. This observation leads him to propose that CP complements follow V', the same conclusion proposed by Karimi (1989). Although Darzi's finding supports my claim that CP complements follow V', his argumentation cannot be adopted here, since extraposition or right-adjunction is excluded by the LCA. Although the results of the advocates of the post-verbal base generation of CP complement also support this conclusion, their argumentation is incompatible with mine too. The distribution of CP complements lends support to their post-verbal generation. Our finding that the PF realization of the internal clausal argument of the head of VP is the same as its post-verbal base position is one of the determining factors in the analysis of Persian VPs and the position of the head V' and its complement. In conclusion, while NP complements precede or follow V' in an unmarked reading, CP complements follow V' unexceptionally, suggesting that their post-verbal position is the base position of any internal complement of V'. That is to say, Persian VPs are head-initial. In cases where an NP complement precedes V', the operation Move has placed this NP in the pre-verbal position. The LCA and the position of CP complements are not the only evidence supporting a head-initial analysis of Persian. As discussed in the following section, clitics display special characteristics which provide additional support for a head-initial analysis of Persian VPs.

#### 4.4.2.3 Placement of Clitics: Another Argument in favor of a Head-Initial Analysis for VPs in Persian

Persian clitics are called “reduced pronouns” by traditional grammarians, and are referred to as “dependent pronouns” (Soheili-Isfahani 1979: p.27) and “pronominal enclitics” (Ghomeshi: 1996: p.157). In generative literature, they exclusively appear post-verbally in PF. Sentences with clitics and their non-cliticized equivalents are illustrated in (43):

- |                                                                                                |                                                                |
|------------------------------------------------------------------------------------------------|----------------------------------------------------------------|
| <p>(43) a. āraš did-eš<br/> <i>Arash saw-CL (3 Sg)</i><br/>         “Arash saw him.”</p>       | <p>*a'. āraš eš did<br/> <i>CL</i></p>                         |
| <p>b. āraš bābā-š-o did<br/> <i>Arash dad-his-rā saw</i><br/>         “Arash saw his dad.”</p> | <p>b'. āraš did bābā-š-o<br/>         “Arash saw his dad.”</p> |
| <p>c. āraš un-o did<br/> <i>Arash him-rā saw</i><br/>         “Arash saw him.”</p>             | <p>c'. āraš did un-o<br/>         “Arash saw him.”</p>         |

(43a) is a grammatical sentence in which the clitic *eš* appears post-verbally, contrary to the ill-formed (43a') in which the clitic is placed before *V'*. An internal NP argument may occur either in a pre-verbal position (43b) or in a post-verbal position (43b'). As shown in (43c, c'), pronominal NPs have the same freedom of occurrence as the nominal NPs in (43b, b'). The examples in (43) indicate that the exclusive position of Persian clitics is post-verbal. Whether or not the PF realization of clitics can denote to their post-verbal base generation will be discussed later, following a discussion of the argumental status of clitics.

Ghomeshi (1996), which is the only study of Persian clitics, rejects the generation of the clitics in the relevant argument position. She recalls that in this kind of analysis, the clitics appear as sister to the verb and then move to adjoin to the head that governs them. She rules out this approach based on the two following theoretical problems. First, a phrasal

constituent (the DP argument containing the clitic) is moving to adjoin to a head, which is a case of XP movement to X\*, a movement which is banned by the theory. I later claim that this is not movement of a phrasal category to a head, but rather an instance of head-to-head movement. Her second objection to this approach stems from the assumption of Monosemy followed in her work. Under this assumption, if two morphemes are identical in form, it follows that they also have the same morphological, syntactic and semantic properties (Ghomeshi 1996: p.6). At least in the case of clitics, this assumption brings about problematic results. Ghomeshi (1996) considers that possessive clitics are the same as clitics used as objects of verbs just because they are “identical in form”. However, I suggest that these two kinds of clitics are syntactically and semantically different as illustrated in (44):

- |                                          |                                                 |
|------------------------------------------|-------------------------------------------------|
| (44) a. Clitics as Possessors            | b. Clitics as objects of Verbs                  |
| ketāb-eš<br><i>book CL</i><br>“his book” | xarid-eš<br><i>bought it</i><br>“He bought it.” |

The uncliticized equivalents of (44a, b) are shown in (45):

- |                                                      |                                                          |
|------------------------------------------------------|----------------------------------------------------------|
| (45) a. ketāb-e u<br><i>book Ez he</i><br>“his book” | b. xarid un-o<br><i>bought it -rā</i><br>“He bought it.” |
|------------------------------------------------------|----------------------------------------------------------|

The comparison of (44) and (45) indicates that in the (a) examples, the clitic and its non-cliticized equivalent carry genitive case, while in the (b) examples, they carry accusative case as indicated by postpositional morpheme *rā* which follows direct objects. This difference undermines Ghomeshi’s second objection to the generation of clitics in the internal argument position of V\*, in which she states “no generalization can be made about the position in which the clitic originates” (Ghomeshi 1996: p.160). In other words, I

maintain that these two kinds of clitics belong to different categories which makes the generalization unnecessary. Having rejected Ghomeshi's second objection to the treatment of clitics as arguments of V', later I will show that the movement of clitics is a case of head-to-head movement not movement of XP to X' which is Ghomeshi's other objection to considering clitics as the internal arguments of V'. But before presenting my own analysis of Persian clitics, which to a great extent resembles the analysis first proposed by Kayne (1991) for French clitics, I give a summary of the main approaches to this topic.

In the generative approach to the study of language, there are two widely held types of analysis of clitics. The older analysis or the "classical" one was introduced by Kayne (1975) and argues that clitics are base-generated in the position XP\* and are Chomsky-adjoined by a movement operation to an appropriate verb up the tree, as shown in (46):

- (46) Marie les<sub>i</sub> aura présentés XP<sub>i</sub>\* à Louis.  
*Mary them will-have introduced-AGR<sub>i</sub> to Louis.*  
 "Mary will have introduced them to Louis."

The basic motivation for the movement analysis is the apparent complementary distribution between clitics and their associated XP' found in French illustrated in (47):

- (47) a. Marie connaît Louis.  
*Mary knows Louis*  
 "Mary knows Louis."  
 b. Marie le connaît.  
*Mary him knows*  
 "Mary knows him."  
 c. \*Marie le connaît (à) Louis.  
*Mary him knows to Louis*

The second approach to clitics, probably most widely held today in one form or another, are base-generation analyses which argue that clitics are base-generated in their

surface position. Proponents of this analysis introduced by Jaeggli (1982) have challenged Kayne's proposal on the basis of the existence of clitic doubling constructions found in languages such as River Plate Spanish shown in (48)<sup>6</sup>:

(48) Lo vimos a Juan  
*him saw-we to John*  
"We saw John."

In (48), both a clitic and a full phrase seem to compete for the same grammatical function. Supporters of the base-generation analysis for clitics have argued that this approach is compatible with the lack of complementary distribution between the clitic and the full XP\* (clitic doubling construction), an advantage, they claim, the movement analysis does not capture.

In a new approach to the study of clitics, Sportiche (1998) tries to reconcile the two dominant approaches on this topic. His analysis treats them as involving both movement and base-generation and assimilates the syntax of clitics to that of other functional heads. Accordingly, a clitic is analyzed as heading its own projection and as licensing in its specifier a particular property of a designated argument agreeing with it in the relevant features. In the analysis I propose for Persian clitics, I follow Sportiche (1998) and argue that a clitic is the head of a Clitic Phrase (CLP), but I argue that this phrase is subcategorized for as the complement of V', which is in contrast with Sportiche's basic idea. The LCA entails that the complement be to the right of the head of the same phrase. Therefore, CL' is base-generated to the right of V'. Then, CL' moves higher up, yielding the PF realization of the expression. This movement adjoins the head CL' to a higher head in the tree, and, based on the LCA assumptions, the adjoining head will invariably precede the head it adjoins to

---

<sup>6</sup> Examples are from Sportiche (1998). This book presents a complete study of clitics, and mentions other advocates of each approach to the subject.

(Kayne 1994: p.38). This movement produces the correct string in French and Spanish examples mentioned in (46), (47), and (48). But, as shown in (43), Persian clitics invariably follow the verb. To overcome this problem, I follow Kayne (1991) in treating cases of clitic adjoining to the right (such as of an infinitive in Italian) as left-adjunction of the clitic to an abstract functional head, plus movement of the infinitive past the clitic (Kayne 1994: p.137).

In Italian, clitics follow embedded infinitives as illustrated in (49):

- (49) Parlargli sarebbe un errore (Kayne 1991: p.648)  
*to-speak him<sub>DAT</sub> would-be an error*

The post-verbal PF realization of clitics in such Italian examples is similar to the occurrence of Persian clitics in all kinds of sentences. This approach undermines Ghomeshi's (1996) first objection to the generation of clitics in argument positions, since it treats the movement of clitics as a case of head-to-head movement not as movement of a maximal projection to a head. Also, this approach invalidates Halpern's (1995: p.57) claim that "clitics are adjoined to maximal projections". Prior to presenting my proposal for Persian clitics, I address the incompatibility of a base generation analysis and the notion of "clitics as heads". That is to say, if clitics are heads, they cannot be in their base position. Supposing clitics as heads and also considering their PF realization as their base position concludes that the phrase that the CL' complements has two heads, which is not allowed (Kayne 1994: p.8).

Now, turning to Persian, I propose the structure in (50b) for the sentence in (50a) in which the clitic is the internal argument of the verb. Recall that this analysis is based on Kayne (1991) which proposes that the clitic is the complement of V' and adjoins to an inflectional head by movement.

- (50) a. xarid - eš  
*bought-3Sg CL*  
 "He bought it."

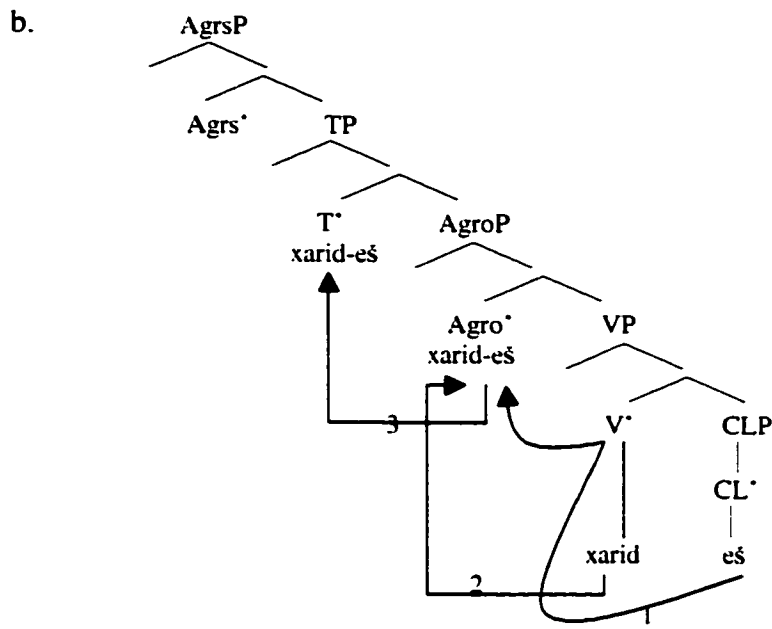

In (50b), the CL' *eš* heading the CLP, which is the internal argument of V', in search of a functional head moves upward. This movement which is similar to the occurrence of clitics in Italian embedded infinitives discussed before, carries CL' to the first available head which is V'. But V' is a lexical head, not a functional head, and we propose that the CL' needs a functional target. Therefore, CL' moves higher up and adjoins to the next available head which is Agro'. In the next step, V' moves up and adjoins to the left of CL' in Agro' and the string V' + CL' is formed. In the last step, the set V' + CL' moves to T' for feature checking and the phonetic form is realized.

The analysis of clitics is not complete, unless the “clitic doubling construction” in which a CLP and a DP seem to compete for the same grammatical function, i.e. the internal argument of V'. is investigated. Like River Plate Spanish exemplified in (48), Persian allows clitic doubling as shown in (51):

- (51) *xar – id - eš ketāb-o*  
*bought-he-CL book rā*  
 “He bought the book.”

In (51), two constituents, i.e. the clitic *eš* and the DP *ketāb-o* “book-rā” seem to occupy the internal argument position of the V\* *xarid* “bought”. I argue that in this case, it is only the CLP which is subcategorized for as the complement of V\* to the right, and the DP, in turn, is selected by CL\* as its complement to its right as illustrated in (52)<sup>7</sup>:

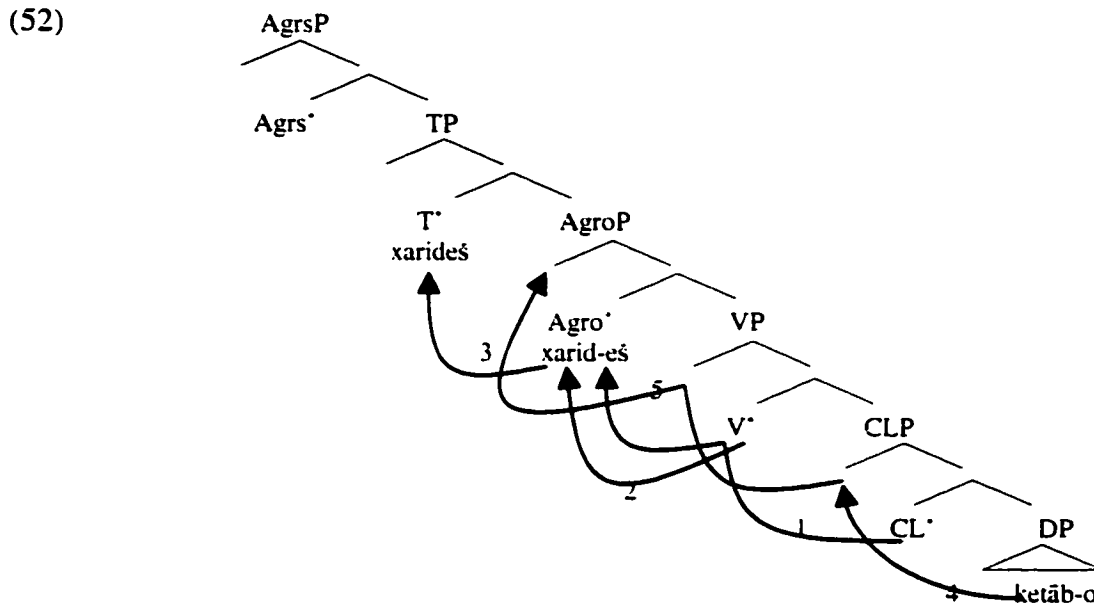

In (52), the DP *ketāb-o* “book-rā” moves up to Spec CLP for the purpose of Spec-Head agreement. If there is such an agreement between the clitic and its doubling (the DP), the process of derivation continues and DP moves higher up for feature checking. The next available slot is Spec VP which is filled by Subj, therefore it moves higher and ends up in Spec AgroP. The movement of CL\* is the same as the one proposed for (50), which will place the string V\* + CL\* in T\*. The final outcome of these movements will be the string in (51).

<sup>7</sup> This analysis is similar to Uriagereka’s proposal that “the doubled phrase is the specifier of a determiner head, the clitic” (Uriagereka 1995: p.80), as the tree shows:

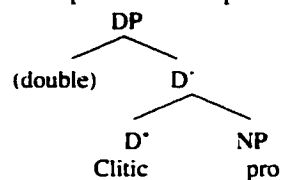

To sum up this section, I proposed that clitics in Persian are selected to the right of V° by the operation Merge. Within an analysis that combines some of the ingredients of Kayne’s original movement proposal with ingredients coming from the “clitic doubling” proposal of Uriagereka, the consecutive movements produce the PF realization of the sentence which is the same as its underlying structure. In my analysis, the selection of clitics as the internal arguments of verbal heads to their right provides additional evidence for a head-initial analysis of Persian VPs. This argument, however, is weakened by the hypothesis that clitics undergo movement.

#### 4.4.2.4 The Occurrence of Adverb between V° and its Complement<sup>8</sup>

The last piece of evidence in favor of the post-verbal generation of VP complements comes from the position of adverbs illustrated by the examples in (53) and (54):

- (53) a. āraš bābā-š-o did  
*Arash dad-his-rā saw*  
 “Arash saw his dad.”
- b. āraš bābā-š-o diruz did  
*yesterday*  
 “Arash saw his dad yesterday.”
- (54) a. āraš did bābā-š-o
- \*b. āraš did diruz bābā-š-o

In (53) the VP is head-final, while in (54) it is head-initial. In the (b) sentences, an adverb

<sup>8</sup> My inspiration for this discussion comes from Stowell (1981) and Zwart (1993). Contrary to this analysis, others have argued that the first step in building up a VP is that adverbs are not the outermost adjuncts of V but rather its innermost complement. This idea is stated in Larson 1988:p.345, footnote 11:

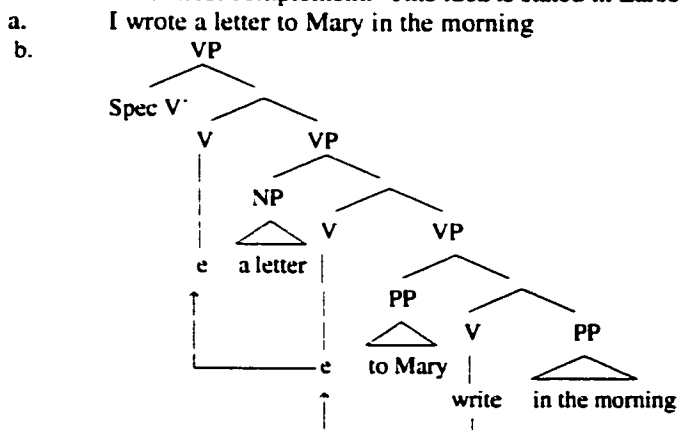

intervenes between V' and the internal argument, resulting in the well-formed string in (53b) and the ill-formed one in (54b). Assuming that the first step in building up the VP via Merge consists in combining the verb with its internal argument, non-adjacency of the Obj and V' can only arise as a result of movement. That is, in (53b), Obj is not in its base position, but in a derived position resulting from a movement. The situation in (54b) is different: an adverb intervenes between V' and its complement and prevents the verb from governing its complement, and the string is ill-formed. This observation indicates that in (53b), Obj is not in its base position. Adverbs other than adverbs of time behave similarly as shown in (55) and (56):

- (55) a. āraš sib-o xord.  
*Arash apple-rā ate*  
 "Arash ate the apple."  
 b. āraš sib-o tond xord.  
*quickly*  
 "Arash quickly ate the apple."
- (56) a. āraš xord sib-o  
 \*b. āraš xord tond sib-o.

Like (53) and (54), these examples indicate that Obj is not in its base position, but has moved to a derived position. This observation supports the post-verbal generation of VP complements or a head-initial analysis of Persian VPs.

## 4.5 Dative Constructions

### 4.5.1 Introduction

Up until now, in the analysis of Persian VPs, I investigated verb phrases comprised of three main constituents: the head V' whose specifier position to the left is filled by Subject, and whose complement position to the right is filled by Object. Thus far, I have argued for a head-initial VP for Persian which implies an underlying SVO word order for Persian

sentences. This analysis would not be complete without examining the position of the indirect object (IO) as well.

IOs exclusively appear as PPs in Persian. This characteristic makes Persian similar to French and Spanish and different from English. No. (57) illustrates the English double object construction. In (57a), the IO is realized as a PP in a V NP PP configuration; but in (57b), it follows V' and is realized as an NP in the structure V NP NP:

- (57) a. John gave a book to Mary.  
b. John gave Mary a book.

Although both (57a) and (57b) are called double object constructions, the latter is normally referred to as a double object construction, while sentences of the type shown in (57a) are referred to as examples of the Dative Construction (Fujita 1996). Unlike English, but like French and Spanish, Persian does not have structures such as (57b), as (58) illustrates:

- (58) a. ali ketāb rā be u dād  
*Ali book-rā to him gave*  
"Ali gave the book to him."  
\*a'. ali u ketāb rā dād
- b. Jean a donné un livre à Marie. (French)<sup>9</sup>  
*John has given a book to Mary.*  
"John has given a book to Mary."  
\*b'. Jean a donné Marie un livre
- c. Juan dio un libro a Maria. (Spanish)  
*John gave a book to Mary.*  
"John gave a book to Mary."  
\*c'. Juan dio Maria un libro.

Before presenting my analysis of Persian datives, I review Larson's analysis for double object constructions in English. Larson (1988, 1990) derives the dative construction of (57a)

---

<sup>9</sup> French and Spanish examples are from Larson (1988).

and the double object construction of (57b) from the structures shown in (59) and (60), respectively:

(59) a. [<sub>VP</sub> V NP1 P NP2]

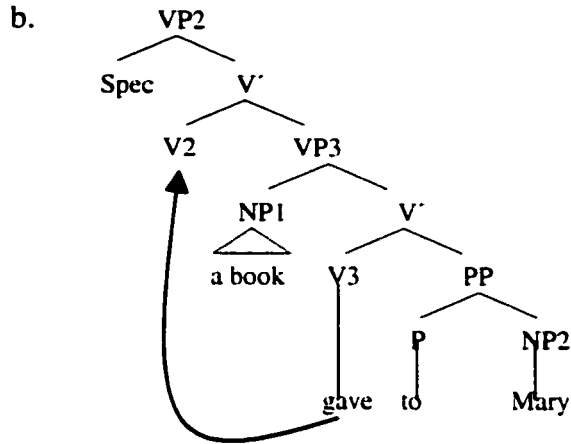

(60) a. [<sub>VP</sub> V NP2 NP1]

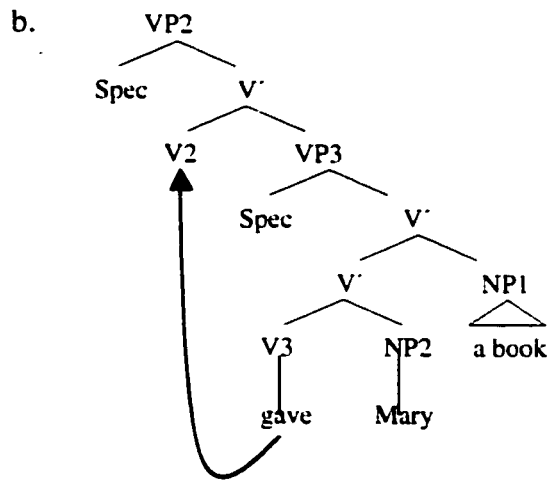

In (59b), V3 raises to V2 to derive the surface order. In (60b), NP1 is first demoted to an adjunct position from [Spec VP3], to which NP2 moves instead. V3 again raises to V2 and the surface order results. As mentioned earlier, Persian allows only the counterpart of (59a) as shown in (58a); that is, the string [<sub>VP</sub> V NP1 P NP2]. Therefore, the easiest way to analyze Persian datives is with a structure similar to that of (59b) which Larson proposed for

English datives. But this analysis needs some refinement to be compatible with the LCA principle of Spec-Head-Complement order, because in (59b), the DO “a book” which is the complement of V3 “gave” precedes it underlyingly.

#### 4.5.2 A Proposal for Persian Dative Constructions

As the projection of V\*, VP is not permitted to have more than one complement based on Kayne’s claim that “the two complements would asymmetrically c-command subparts of each other and produce a violation of antisymmetry (Kayne 1994: p.69)”. Thus the LCA does not allow two complements for V\* in a sentence like (61):

- (61) āraš sib-o be bābā dād  
 Arash apple-rā to dad gave  
 “Arash gave the apple to Dad.”

In (61), the Obj *sib-o* “apple” is selected by the V\* *dād* “gave” as its internal argument. Its base position is to the right of V\*, prior to raising for feature checking, as it is discussed in 5.3. The LCA does not approve *be bābā* “to dad” as another complement for V\*. Also, *be bābā* “to dad” cannot be considered as a case of right adjunction to VP, due to the impossibility of this process under the LCA. Thus, another explanation of Persian Datives is needed.

One possibility would be to consider the IO as the complement of the N\*, head of the NP, the internal argument of V\*. Contrary to English which has a non-Dative alternative for (6!) as shown in (62), Persian only allows IOs to appear as PPs:

- (62) Arash gave Dad the apple.

In our discussion of Persian DPs/NPs, we said that PP is one of the XPs that can be selected by a head N\* as its complement to the right. Thus, IO can be selected by the N\*, head of the Obj to the right, yielding the configuration shown in (63):

(63)

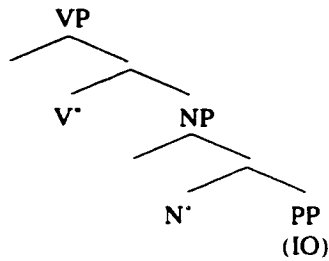

A problem appears when N\* has other modifiers following N\* as the complement selection of Persian N\*s allows. This case is shown in (64):

(64) a. āraš sib-e ruye miz-o be bābā dād.  
*Arash apple-Ez on table-rā to dad gave*  
 "Arash gave Dad the apple on the table."

b.

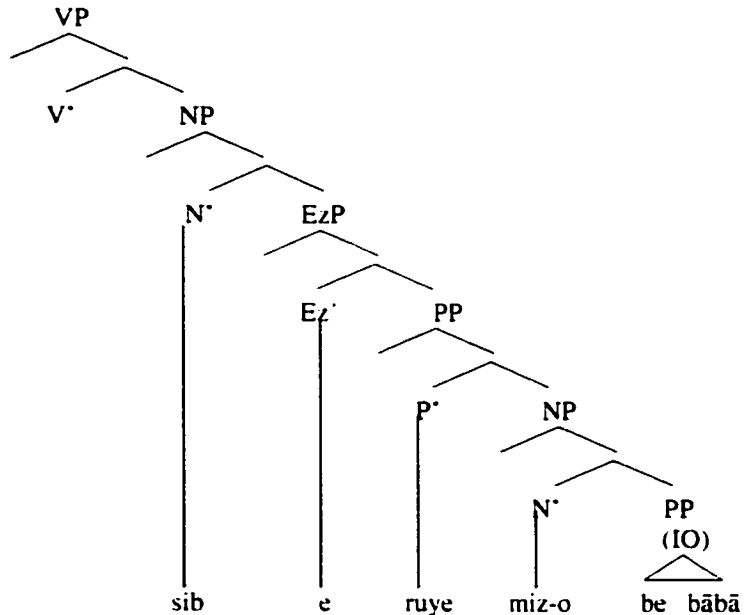

In (64b), *be bābā* "to dad" is not the complement of *sib* "apple", but the complement of *miz-o* "table". This is an unwanted conclusion, because as we saw in (63), IO can be the complement of the highest N\*, head of NP, complement of V\*, not the complement of the lower NP as shown in (64b). To overcome this deficiency, I follow Larson (1988, 1990)<sup>10</sup>

<sup>10</sup> Larson's (1988, 1990) proposal was discussed earlier in Chapter 3, p.73, footnote 4.

and propose that IO originate as the complement of V\*, head of the lower VP in a VP-shell as shown in (65)<sup>11</sup>:

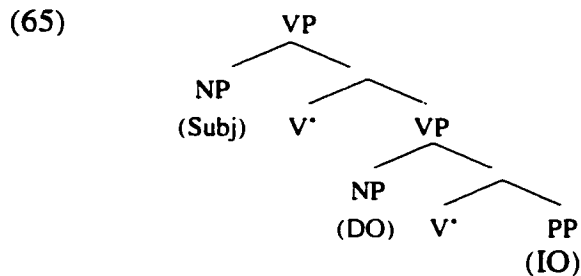

In the Larsonian shell in (65), Subj originates as the specifier of the higher V\*. DO as the specifier of the lower V\* and IO as its complement. This analysis has some advantages which make it plausible. First, the underlying SVO order is maintained for Persian. Second, the problem brought about in (64) is avoided. Third, different PF word orders can be delicately explained. That is, the PP in the complement position of V\* and the NP in its Spec move higher up to the relevant specifier positions for feature checking, yielding different possible orders.

<sup>11</sup> An alternative for the structure proposed here for Datives is the one which considers IO as an adjunct, as shown in the following tree:

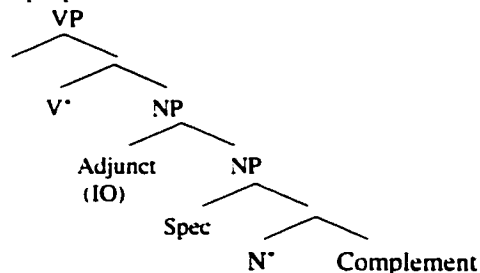

In this structure, in addition to one Spec, an adjunct is supposed for N\* which contradicts the LCA and so it is ruled out. Cinque (1996) suggests that a definition of *c-command* slightly different from the one assumed in Kayne (1994) would allow for phrases with multiple Specs/ Adjuncts. This alternative, however, loses the essence of the LCA which is an empirically undesirable move (Cinque 1996: p.450).

To conclude, the analysis of Persian Datives follows the LCA assumptions and justifies the occurrence of indirect objects in a head-initial VP within the general Spec-Head-Complement order.

#### **4.6 Summary and Conclusion of the Analysis of Persian VPs**

In my analysis of Persian verb phrases, I adopted the VP-Internal Subject Hypothesis according to which the verb and both its internal and external arguments originate in the VP. The order of those three constituents determines the underlying sentence word order of any language. Following a review of studies of Persian word order, I noted that the *more frequent* word order was SOV, both for written and colloquial Persian. This observation has led all linguists, except Marashi (1970), to posit the more frequent order (SOV) as the underlying order. After demonstrating that V' can select its complement to the right or left in unmarked situations, I sought evidence to support either a VO or OV word order. In the absence of any syntactic evidence in favor of a head-final VP for Persian, I argued for the alternative word order. Starting from the observation that both OV and VO are used in Persian unmarked structures, I argued that it is preferable to choose one order over the other. On the basis of post-verbal position of CP complements, the position of clitics and the occurrence of adverbs between verbs and their complement, I argued for a head-initial analysis of Persian VPs, and an underlying VO word order. These arguments are all compatible with the theoretical foundations of this research based on which all heads select their complements to the right. The final conclusion is that in Persian, VPs are head-initial; that is, the verb precedes its internal argument and follows its external argument, located in Spec VP. In other words, Persian VPs have a basic Spec-Head-Complement configuration.

just like other maximal projections discussed thus far. The next step in the analysis of Persian syntax will be the structure of sentence, or in the present terminology, the functional categories dominating VP.

## **Chapter 5**

### **An Overview of Other Phrases**

#### **(APs, PPs, IPs, CPs, TopPs)**

The extensive investigation of nominal phrases and verb phrases in previous chapters concluded in a basic head-initial order for these categories in Persian. In passing, in the study of DPs, it was shown that maximal projections which fill the specifier position of D' and N' or are selected as their complement appear in a head-initial configuration. In this regard, the analysis of the QP, NumP, DemP, EzP, AP and PP all follow the general Spec-Head-Complement order. In this chapter, I examine the structure of APs and PPs in detail. I also show that the process of feature checking occurs in a head-initial IP which is split into a head-initial AgrsP, TP and AgroP, respectively. This process changes the *basic* SVO verb phrase to sentences with different possible word orders. The chapter concludes with an examination of CPs and TopPs.

#### **5.1 Persian Adjective Phrases**

To begin my analysis of Persian adjectival phrases, I first examine the distinction between attributive and predicative adjectival phrases. Traditionally, DP-internal APs are considered attributive and post-copular APs are called predicative APs. Cinque (1995) challenges this notion and claims that DP-internal APs can be either attributive or predicative, and states that in both Germanic and Romance languages, attributive APs are generated to the left of

the N while predicative APs are to its right<sup>1</sup>. This idea is exemplified in (1) where an attributive adjective precedes N<sup>o</sup> in (1a) and a predicative adjective follows it in (1b):

- (1) a. a nice man  
b. a man interested in linguistics

That the right peripheral position is a predicative one in English (similar to other Germanic languages and to Romance languages) is shown by the fact that no AP can occur there which cannot also occur in post-copular position, as shown in (2):

- (2) a. \*the indignity, utter and simple  
b. \*the indignity was utter<sup>2</sup>

Now, in the light of these general definitions, and considering the special distribution of APs in Persian DPs as discussed earlier (p.72), notice (3) which illustrates three cases of APs:

- (3) a. *behtarin ketāb-e sāl*  
*best book- Ez year*  
"the best yearbook"
- b. *dānešju-ye negarān-e āyande*  
*student-Ez anxious- Ez future*  
"the student anxious about future"
- c. *u negarān-e āyande ast*  
*he anxious- Ez future is*  
"He is anxious about future."

In (3a), the adjective *behtarin* "best" precedes the N<sup>o</sup> *ketāb-e sāl* "yearbook" in an NP. In (3b), the N<sup>o</sup> *dānešju* "student" is modified by the AP *negarān-e āyande* "anxious about future" which follows the head of NP. And in (3c), the same AP is used in a sentence with the linking verb *ast* "is" in the pre-copular position. As I discussed in Chapter 3, the

---

<sup>1</sup> Cinque 1995: p.205, footnote 12.

<sup>2</sup> Example is from Abney 1987: p.328.

adjective is located in Spec NP in (3a), but in (3b) the AP as the complement of N occurs to the right in an EzP as shown in (4):

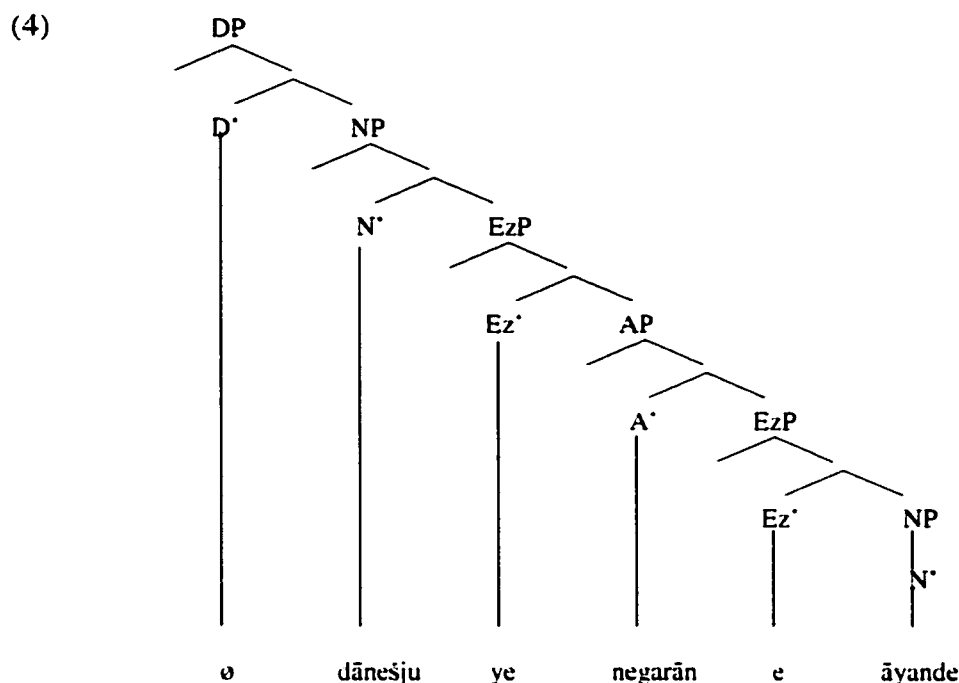

These facts in addition to our findings in the study of Persian DPs discussed before lead me to a general analysis for APs in Persian. There, I discussed that various APs can be subcategorized for as the complements of N' to its right in an EzP. Also, I showed that in the pre-N' position, there is a small closed class of adjectives that occur in Spec NP. Considering these facts and along the lines followed in this thesis, and in conformity with LCA assumptions, I propose a uniform analysis for Persian APs, whether supposed as attributive or predicative, in a manner which A' heads the phrase and selects its complement to the right. The complement is an EzP which, in turn, selects its NP or PP complement. This phenomenon is illustrated in (5):

- (5) a. dānešju-ye alāqemand-e zabānšenāsi  
*student-Ez interested - Ez linguistics*  
 "the student interested in linguistics"

- b. *dānešju-ye alāqemand-e be zabānšenāsi*  
*student-Ez interested - Ez to linguistics*  
 "the student interested in linguistics"

In both (5a) and (5b), the noun *dānešju* "student" is modified by a post-N° AP complement. Each AP which, in turn, is selected by *Ez°*, is headed by the A° *alāqemand* "interested" and subcategorizes for another *EzP* as its complement to the right. In the AP in (5a), the complement of *EzP* is the NP *zabānšenāsi* "linguistics"; but in (5b), the complement of *EzP* is the PP *be zabānšenāsi* "in linguistics". In both cases, Spec AP is to the left of A°, head of AP, and is reserved for an adverbial phrase (AdvP). If filled, the AdvP is realized as an Adv°, as shown in (6):

- (6) *kāmelan šifte-ye elm*  
*absolutely fond-Ez science*  
 "absolutely fond of science"

Thus, in cases like (5a) and (6) where the complement of *EzP* is an NP, the structure proposed is that shown in (7), and in a case like (5b) where *EzP* has a PP complement, it is the structure found in (8):

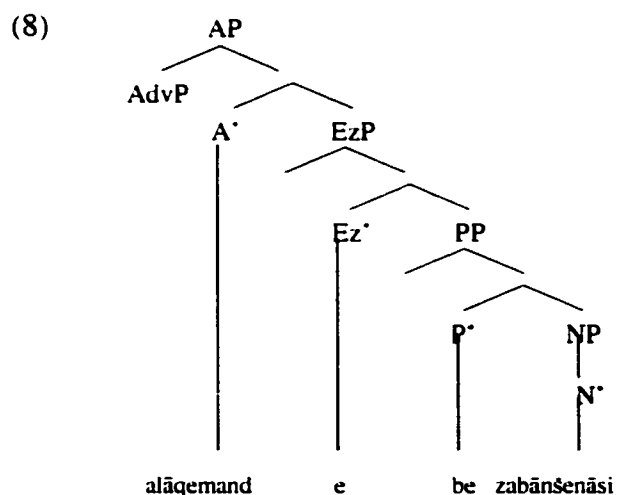
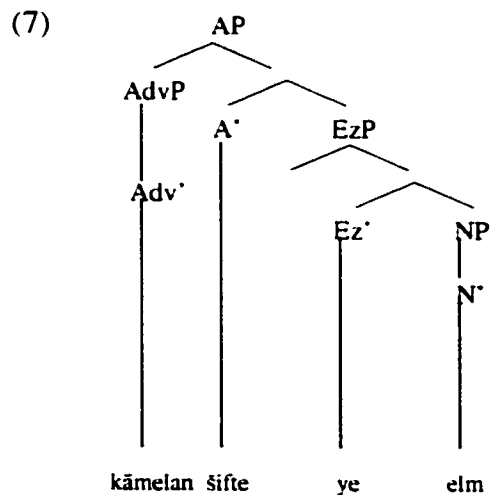

It should be noted that the presence of  $Ez'$  in (7) is obligatory; but in (8), due to the presence of  $P'$ , the phonetic realization of  $Ez'$  will be neutralized. Therefore, (5b) can be displayed as in (9) to embed this characteristic:

(9) *alāqemand-(e) be zabānšenāsi*

In addition to the structure of APs analyzed above in which the  $A'$  subcategorizes for its complement to the right, and implies an exclusive head-initial status for this category in Persian, there is a case where a PP precedes  $A'$  as shown in (10):

- (10) a. *u alāqemand-e be zabānšenāsi ast*  
*he interested -Ez to linguistics is*  
 "He is interested in linguistics."  
 b. *u be zabānšenāsi alāqemand ast*  
*he to linguistics interested is*  
 "He is interested in linguistics."

(10a) and (10b) carry the same meaning. In (10a), the AP *alāqemand-e be zabānšenāsi* "interested in linguistics" is used in the structure discussed and proposed earlier; but in (10b), the PP *be zabānšenāsi* "in linguistics" precedes the  $A'$ . Isn't it the case that in (10b), the complement of  $A'$  precedes its head, contrary to the assumptions of this research? As a matter of fact, (10b) does not contradict the assumptions followed in this research. In my analysis, I argued that the complement of  $A'$  is an  $EzP$  which, in turn, selects an NP or PP as its complement. In (10b), there is no evidence of an  $EzP$  to be considered as the complement of the  $A'$  *alāqemand* "interested". That is to say, the PP *be zabānšenāsi* "in linguistics" is generated outside the AP, in the verb phrase. In other words, in (10b), the adjective *alāqemand* "interested" forms a compound verb with the verb *ast* "is" and the PP *be zabānšenāsi* "in linguistics" behaves as the complement of the newly formed compound

verb generated under  $V^{*3}$ . The complement is selected to the right of the  $V^*$  *alāqemand ast* “is interested” by the operation Merge. But in our example in (10b), in which the PP complement precedes the  $V^*$ , I propose a layered VP in which the PP originates as the complement of the lower  $V^*$  and then moves to the specifier position of the same head, yielding the order in (10b). Thus, (10c) is the tree for (10b):

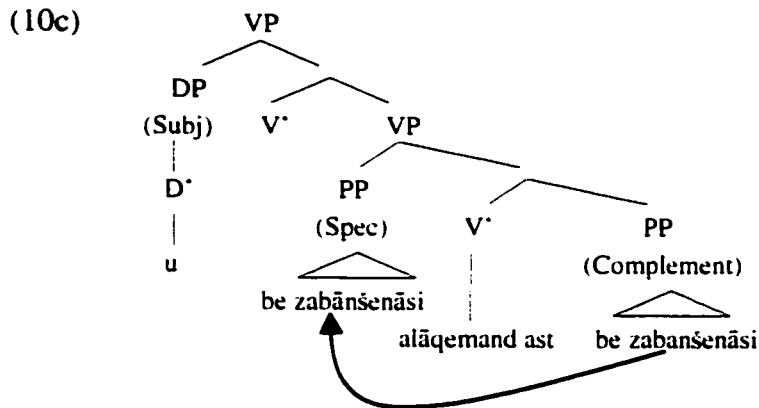

The process of making compound verbs by putting an adjective and “be” together is very productive in Persian. This analysis for (10) rules out the possibility of generating the complement of  $A^*$  to its left, and hence the assumption of head-initial APs can be maintained. To conclude this section, we observed that APs in contemporary Persian display a head-initial status in which  $A^*$  selects its complement to the right. The complement is an EzP which, in turn, subcategorizes for its complement an NP or PP. Then, the set “ $A^*$  + Complement” projects into an AP with a Spec filled with an AdvP to its left. This analysis confirms that Persian APs are, like the other maximal projections studied thus far, head-initial.

<sup>3</sup> The justification for cases like (10) is essentially inspired by Samiian (1983): p.239.

## 5.2 Prepositional Phrases in Persian

Similar to other phrasal categories in Standard Colloquial Persian discussed so far, PPs follow the same restriction relative to the order of their heads and other constituents of this phrasal category in this language. The LCA principles impose a Spec-Head-Complement configuration to prepositional phrases which in the minimalist framework requires that the head select its complement to the right by the operation Merge<sup>4</sup>. In Persian, P<sup>\*</sup>, head of PP, merges with its complement which is a DP<sup>5</sup>. Then, it projects to PP with its Spec to the left of the head. This process is shown in (11):

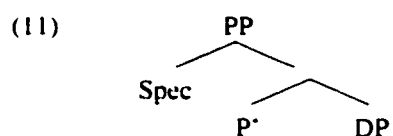

The head of the maximal projection PP is selected from the lexicon out of the list of Persian prepositions. P<sup>\*</sup> is either simple, made of one morpheme, or compound, made of more than one morpheme. In both cases, it is chosen as one lexical item from the lexicon. No. (12) shows two PPs, one with a simple preposition as its head, and the other one, a compound preposition functioning as its head:

- (12) a. dar zabānšenāsi  
*in linguistics*  
“in linguistics”
- b. dar bāreye zabānšenāsi  
*in about linguistics*  
“about linguistics”

---

<sup>4</sup> That Persian is prepositional implies that it is not an SOV language, as Greenberg’s Universal 4 states. “with overwhelmingly greater than chance frequency, languages with normal SOV order are postpositional (Greenberg 1963: p. 79).

<sup>5</sup> In Persian, there is not agreement between P<sup>\*</sup> and its DP complement. This characteristic can be considered as another piece of evidence in favor of an SVO order for this language, as Kayne narrates from Kenneth Hale (personal communication) that PPs in SVO languages never show such agreement (Kayne 1994: p.49).

In (12a), the preposition *dar* “in” selects its complement to the right, as does the compound preposition *dar bāreye* “about” in (12b). Although the head of the PP in (12b) consists of two independent prepositions, I follow Samiian’s (1983) proposal which a PP cannot be the complement of P\*, head of another PP. I propose that in cases like (12b), the compound preposition *dar bāreye* “in about” is a single lexical item formed pre-syntactically. Therefore, (12b) will have the configuration in (13a) not (13b):



Only DPs can be selected as prepositional complements. The exclusive Merge of a DP with P\* is not specific to Persian. Samiian (1983) notes that Hendrick (1976) claims that “prepositions have objects but no prepositional or sentential complements in the base. All such complements to prepositions are taken by Hendrick to be derived by a rule of Complement Formation.”<sup>6</sup> To express this idea in minimalist terminology, we say that P\* selects its complement only from the maximal projection DP. While Hendrick’s claim is problematic in English where P\* can select a CP or PP as complement in PF, Persian prepositions can only select DP complements to their right, as shown in (13a). What is the role of Spec in PP in our analysis? Actually, supposing Spec for PPs is not only for exhibiting a consistent structure for all phrasal categories, but also Spec PP is reserved for cases like (14):

(14) a. *pošt be divār*  
*behind to wall*  
 “behind to the wall”

<sup>6</sup> Samiian 1983: p.271.

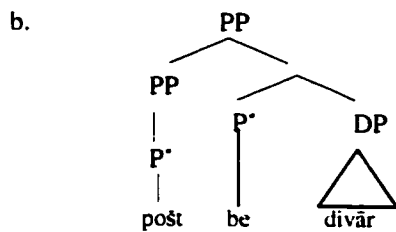

Considering the fact that the prepositions *pošt* “behind” and *be* “to” in (14) do not refer to a unique item, the analysis used for (12b) which produced (13a) is not applicable in this case. Therefore, in (14), the P\* *be* “to” selects its complement DP *divār* “the wall” to its right, and its Spec the PP *pošt* “behind” to the left and projects to PP.

DP, complement of P\*, exhibits all peculiarities of Persian DPs discussed earlier. The EzP can add more complements to it and make the PP longer. No. (15) displays this phenomenon:

- (15) a. *pošt be divār-e bozorg-e ċin*  
*behind to wall-Ez great-Ez China*  
 “back to the Great Wall of China”

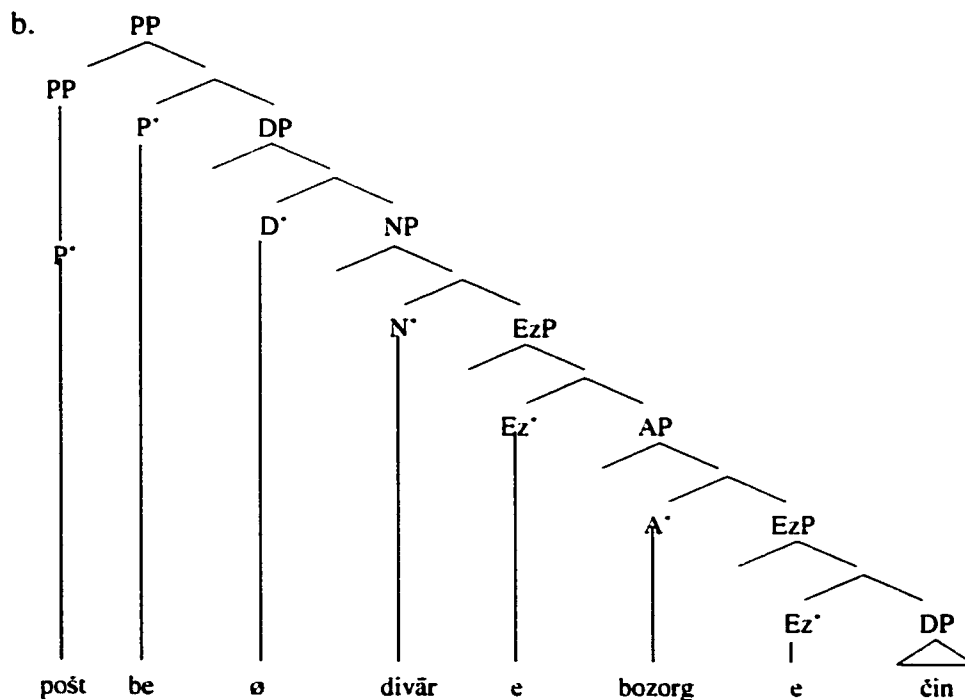

In (15b), the P° *be* “to” subcategorizes for its complement, the DP *divār-e bozorg-e ċin* “the Great Wall of China”. D°, head of the DP which is not phonetically realized, selects its complement NP whose head, the N° *divār* “wall” selects the EzP *e bozorg-e ċin* “Ez great Ez China” as its complement. This EzP, in turn, selects the AP *bozorg-e ċin* “great Ez China” as its complement, and later, the A° *bozorg* “great” selects the EzP *e ċin* “Ez China” as its complement. In the last step, *e* the head of the EzP selects the DP *ċin* “China” as its complement. As shown in (15b), the DP, complement of P° displays all characteristics present in other DPs.<sup>7</sup>

Before concluding our discussion of Persian PPs, there is another point about the P° which should be clarified. Some prepositions in Persian end in the vowel /e/ or /ye/ which is similar to the Ezafe morpheme, head of EzP. This is shown by examples in (16), noted in Samiiian (1983):

- (16) a. *kenār-e miz*  
*next-Ez table*  
 “next to the table”
- b. *barā-ye hasan*  
*for Ez Hassan*  
 “for Hassan”

As (16) shows, Samiiian considers an Ezafe construction, or an EzP in my analysis, for such cases. I depart from Samiiian and agree with linguists<sup>8</sup> who consider the final vowel /e/ or /ye/ in these prepositions to be part of their lexical entry. Thus, (16a) will exhibit a structure as (17) in my analysis:

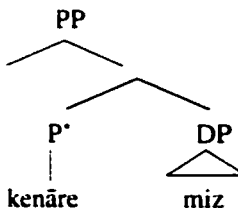
- (17) a. *kenāre miz*  
*next table*  
 “next to the table”
- b. 

<sup>7</sup> A movement analysis in which the N° *divār* “wall” originates in the specifier position of the lower EzP and then raises to the higher positions was discussed in Chapter 3, section 4.

<sup>8</sup> Meshkat al-Dini (1987): p.195.

My investigation of PPs in Modern Persian supports my findings concerning other lexical and functional phrasal categories discussed so far. Exactly the same as those maximal projections, in this language, P' selects its complement to the right from DPs. The same head, that is to say P', will have its Spec to the left, and the maximal projection will be a prepositional phrase (PP). This analysis is in absolute accordance with LCA assumptions in a minimalist framework.

### **5.3 Persian Sentences (IPs)**

In the analysis of VPs, I argued that V' subcategorizes for its complement Obj to the right and its specifier Subj to the left by the operation Merge. These elements are selected from the lexicon with all their features, yielding the VP. In the next step of the derivation, the constituents of VP should check their features with appropriate slots in the functional categories dominating VP. This feature checking which is done either by Agree or Move will result in the structure of a sentence.

The sentence can be viewed as the *extended projection* of V', i.e. the projection of the lexical head V' augmented with the projection of the functional head I'.<sup>9</sup> This results in supposing the sentence as an IP. The functional category IP is a maximal projection which shares the same structure as other XPs, whose head is I' and selects VP as its complement. The interpretation of sentence as IP was questioned when Pollock (1989) proposed the Split-Infl-Hypothesis claiming that IP should be divided into two functional categories TP and AgrP. Following Pollock, other structures were proposed for IP, adding more projections or

---

<sup>9</sup> This definition of the sentence which dates back to Grimshaw (1991) is elaborated in Haegeman & Guéron (1999).

reducing some based on new evidence, e.g. Chomsky (1995) which splits IP to AgrsP, TP and AgroP, and Chomsky (1998) which supposes two functional categories TP and vP above VP. Actually, preference of one structure over another one is not a free choice, but it should be based on strong reasoning and concrete grounds. The structure I am proposing for IP in Persian is basically the one in Chomsky (1995), but with a refinement to TP which harmonizes this structure with LCA assumptions. In Chomsky (1995), TP is defective, because it does not have a Spec. I propose that theoretically TP is not different from any other phrasal category and can have a specifier position. The existence of this specifier position, which is to the left of the head of TP based on the framework followed in this research, is not only theoretically justifiable but also is supported by strong evidence in the literature. Bobaljik & Jonas (1996) show that there are both empirical and theory-internal factors that implicate Spec TP in Germanic *Object Shift (OS)* and *Transitive Expletive Constructions (TECs)*, suggesting a natural place in the theory for parametric variation. These two phenomena are illustrated in the Icelandic examples in (18) and (19)<sup>10</sup>:

(18) NP *Object Shift (OS)*

Jólasveinarnir borðuðu búaðinginni [<sub>VP</sub> ekki t<sub>i</sub>].  
*the-christmas-trolls ate the pudding not*  
 "The Christmas trolls did not eat the pudding."

(19) *Transitive Expletive Construction (TEC)*

Það borðuðu sennilega margir jólasneinar þjúgun.  
*there ate probably many Christmas-trolls the-sausages*  
 "Many Christmas trolls probably ate the sausages."

---

<sup>10</sup> Bobaljik & Jonas (1996): p.195-6.

Bobaljik & Jonas, at first, examine the nature of *OS* in this respect, motivating its use as a diagnostic for the licensing of Spec TP. Then, they introduce empirical evidence that supports Diesing's (1992) claim<sup>11</sup> that there are two overt subject positions in German, extending this claim to other languages and constructions. Assuming the articulated clausal structure in (20) which is basically the same as the one followed in this research, they show that both subject positions are higher than the position of the shifted object Spec AgroP:

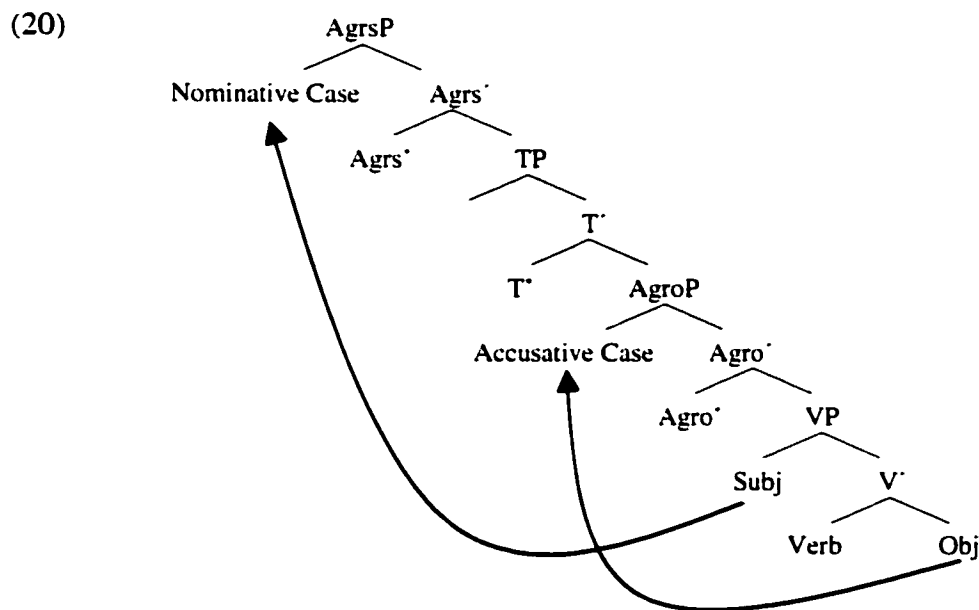

This is their clearest piece of evidence for the existence of Spec TP. I apply Bobaljik & Jonas's conclusion and propose the existence of Spec TP in Persian, but due to the lack of expletive constructions in this language, I argue that Spec AgrsP is the subject position while Spec TP is the landing site for a specific Move which I call "Stylistic Move". This Move is responsible for the SOV order which puts the Obj in the position before V' in PF.

<sup>11</sup> The existence of two positions at LF for the bare plural subject NP has been the inspiration for a parallel for clause structure. Diesing's claim is based on the analyses (e.g. Sportiche 1988) which draw upon the possibility of there being two subject positions in the clause (Diesing 1992: p.357).

My other motivation for adopting the analysis of Chomsky (1995) over Chomsky (1998) is the issue of multiple Specs in the latter which deviates from the LCA assumption of “one Spec- one head”. The above argumentation concludes that in (20), an IP is split into AgrsP, TP and AgroP, respectively, with each functional category a maximal projection headed by Agrs’, T’ and Agro’. As with other head-initial XPs, complement selection is to the right, with Agrs’ selecting TP as its complement, T’ selecting AgroP as its complement, and Agro’ selecting VP as its complement. Specs are reserved for feature checking of internal and external arguments of V’, and T’ is one of the possible landing sites of V’. This analysis is shown in (21):

- (21) a. āraš xord sib-o  
 Arash ate apple-rā  
 “Arash ate the apple.”

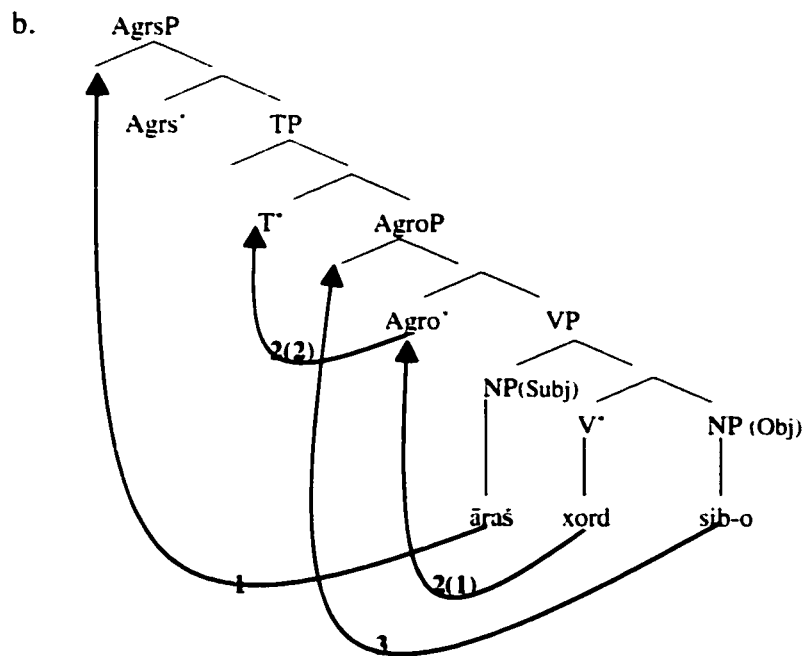

In chapter 4, I argued that the Spec-Head-Complement order is the *base* order by which the constituents of VP merge and VP is built up. This proposal implies that Persian VPs are head-initial, as other maximal projections discussed so far are. Thus, the SVO order in (21a)

mirrors the underlying order. The constituents of the VP are selected from the lexicon and carry some features which should be checked in order to produce the highest functional projection which represents the sentence. The feature checking process is done through the operation Move as illustrated in (21b).

In the first Move, the subject, following the EPP, raises directly without a violation of Minimal Link Condition (MLC) from Spec VP to Spec AgrsP to check its nominative feature. To justify this claim, I agree with Bobaljik & Jonas (1996)<sup>12</sup> that, by hypothesis, specifier positions are freely generated; that is, a potential specifier position is present in the derivation only by virtue of its being filled or targeted by movement (a consequence of the operation Generalized Transformation). The difference between my analysis and Bobaljik & Jonas is that cyclicity was crucial for them to get the typology of languages which was the point of their paper, while there is a violation of cyclicity in the present analysis. I propose that the movements I discuss for Persian apply in PF, and this can violate cyclicity. Whichever specifier position the subject moves to, the movement will not violate MLC, if the specifier positions of the intervening phrases are not present at that stage of the derivation. In the present instance, if Spec AgroP and Spec TP are not filled at the point in the derivation at which the subject raises, then they are not present, and the target Spec AgrsP is the first appropriate landing site. I should add that the subject cannot move to Spec AgroP, because the object cannot then check its accusative feature there, and the move of the subject to Spec TP is not allowed due to another function I propose for this position in Persian which will be discussed next.

---

<sup>12</sup> Bobaljik & Jonas (1996): p.200.

In the second step of the operation,  $V^*$  moves up by the process of head-to-head movement to  $\text{Agro}^*$  and subsequently raises to  $T^*$ . The first phase of this Move,  $V^*$ -to- $\text{Agro}^*$ , makes  $\text{Spec VP}$  and  $\text{Spec AgroP}$  *equidistant* from  $\text{Obj}$ . The notion *equidistance* as proposed by Chomsky<sup>13</sup> solves the problem of moving the complement of  $V^*$  to a specifier position higher than the specifier position of  $\text{VP}$  in the tree without a violation of MLC. This idea can be shown in the structure shown in (22):

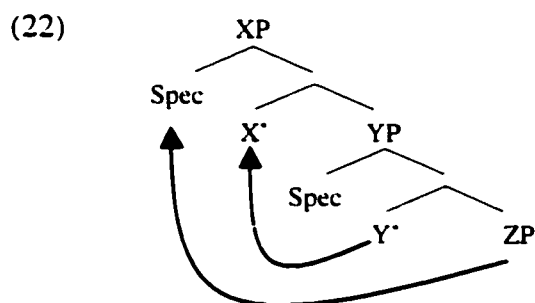

To speak more generally, when a head moves to a higher head, the  $\text{Spec}$  of the unmoved head and the  $\text{Spec}$  of the moved head become equidistant from the complement of the moved head. Thus in, (22), when  $Y^*$  moves to  $X^*$ ,  $\text{Spec XP}$  and  $\text{Spec YP}$  become equidistant from  $ZP$ .

In the final Move,  $\text{Obj}$  raises to check its accusative feature and has two available specifier positions in which to land:  $\text{Spec VP}$  and  $\text{Spec AgroP}$ . Since  $\text{Obj}$  is *equidistant* from both of these  $\text{Specs}$ , it has the option of choosing either of them. However, since  $\text{Spec AgroP}$  is in the functional domain in which accusative case can be checked,  $\text{Obj}$  moves to  $\text{Spec AgroP}$ . These consecutive Moves check the features of the constituents of the  $\text{VP}$  in the appropriate slots in the functional domain and yield the actual order of the sentence which is  $\text{SVO}$ . The process illustrated in (21b) is a case where  $\text{PF}$  word order matches the

<sup>13</sup> Chomsky (1995): p.185 & 356.

underlying structure of the constituents of the sentence. We discussed earlier that Persian has a parallel use of SVO and SOV word orders. However, when PF exhibits an SOV order, there is an extra Move which carries the moved Obj from Spec AgroP to Spec TP, producing the desired order. This last Move, which I call “Stylistic Move”, imposes an extra operation on the derivation as illustrated in (23)<sup>14</sup>:

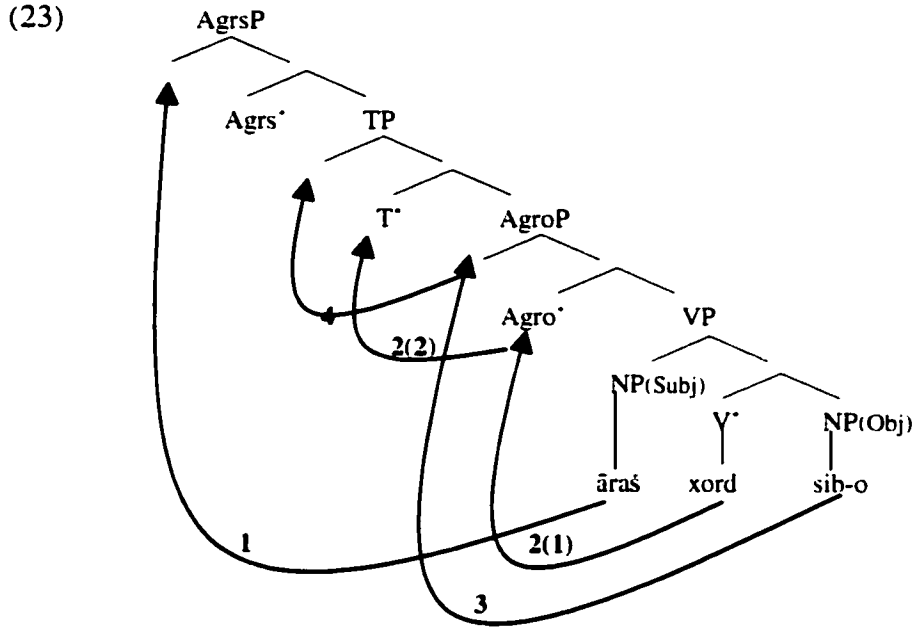

<sup>14</sup> An alternative to the trees in (21) and (23) would be to propose that Obj checks its features with Spec AgroP by the operation Agree resulting in an SVO order, while in the case of SOV order, Obj moves to Spec AgroP to satisfy the relevant features. This analysis brings about the trees in (1) and (2), respectively:

(1) SVO

(2) SOV

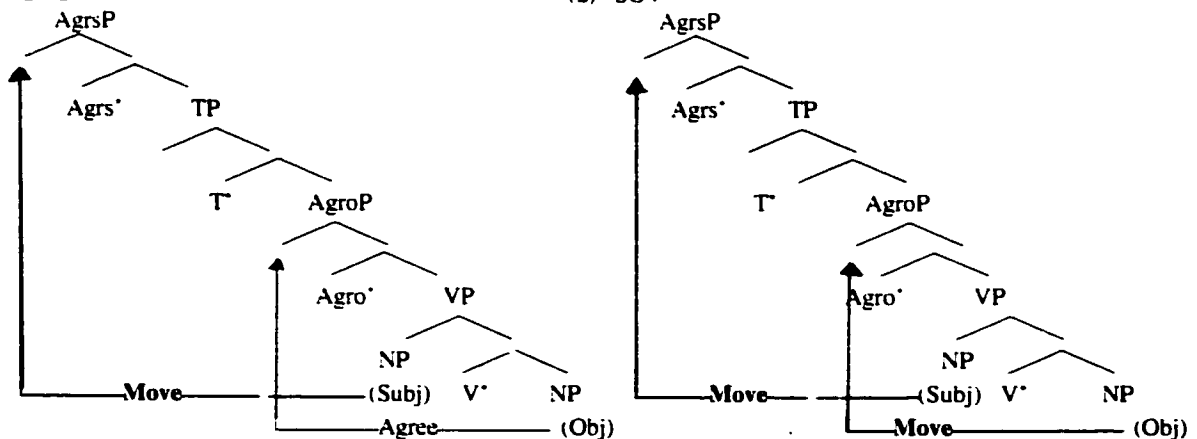

This analysis faces a technical problem: The locality condition is not observed in the operation Agree between Obj and Spec AgroP in (1).

In the structure in (23), compared to (21), there is an extra Move which I called “Stylistic Move”. In the Minimalist program, every movement is motivated by some kind of feature checking, and if all features of some category  $\alpha$ , whether a head or some projection, have been checked, then  $\alpha$  is inaccessible to movement. But if some feature F is as yet unchecked,  $\alpha$  is free to move<sup>15</sup>. In (21), the features of Subj, V’ and Obj are checked, and hence are inaccessible to additional Moves. The situation in (23) is different, as an additional Move carries Obj from Spec AgroP to Spec TP. This extra Move entails that some feature in Obj must have remained unchecked. The unchecked feature cannot be the accusative feature of Obj since Spec AgroP, not Spec TP is responsible for checking the accusative feature of Obj, and since all features of the same kind are checked together<sup>16</sup>. Therefore, if another Move happens, it must be motivated by another kind of unchecked feature. I propose this Move to be a “Stylistic Move” somewhat similar to the *Stylistic Fronting* in Scandinavian discussed in Holmberg (2000). Scandinavian stylistic fronting is an operation that moves a category, often, but not always, a single word, to what looks like the subject position in finite clauses when that position is empty, namely, in subject relatives, embedded subject questions, complement clauses with an extracted subject, and various impersonal constructions. No. (24) illustrates this phenomenon in an Icelandic example from Jónsson (1991):

- (24) a. [Sá sem —er fyrstur að skora mark] fær sérstök verðlaun.  
*he that is first to score goal gets special prize*  
 “The first one to score a goal will get a special prize.”
- b. [Sá sem fyrstur er — að skora mark] fær sérstök verðlaun.

<sup>15</sup> Chomsky (1995): p.266.

<sup>16</sup> “Any given feature may be checked only once in the course of a derivation (Bobaljik & Jonas 1996: p.225).”

(24a) contains a subject relative with a gap between the complementizer *sem* and the finite verb. In (24b) the predicative adjective *fyrstur* appears in that same space, by hypothesis moved there from the post-verbal position. Movement of adjective in (24b) is an instance of the operation called *Stylistic Fronting* or *Stylistic Inversion*. Holmberg (2000) argues that *Stylistic Fronting* is movement of a category to “subject position”, that is, [Spec IP]. The trigger for this movement is a version of the Extended Projection Principle (EPP) in Chomsky (1981) that every sentence should have the form [NP I VP]: every sentence must have a nominal subject in Spec IP<sup>17</sup>. Clearly, the moving element and the target of movement in Holmberg’s analysis is different from mine, but the idea of stylistic movement in this work supports my proposal for a movement of this kind in Persian.

The analyses presented in (21) and (23) apply to cases where Subj and Obj are NPs. CPs cannot be subjects in Persian and hence cannot originate in Spec VP, but they can appear as objects. As discussed earlier, objects, whether NPs or CPs originate post-verbally. While the feature checking of NP complements is done by Move, feature checking of CP complements is done by Agree. In this regard, I follow Koster’s (1994) analysis for NP or CP complements of V\* in Dutch. Assuming an SVO word order for Dutch VPs<sup>18</sup>, he argues that NPs like CPs are generated to the right of V which gives VPs a structure like [V XP]. NPs have a case feature that has to be checked to the left of the verb (i.e. in Spec Agro); so they move to the left and give the normal structure to Dutch sentences. CPs, on the other

---

<sup>17</sup> Holmberg (2000): p.445-6.

<sup>18</sup> Koster’s “Dutch as an SOV language” (1975) establishes SOV as the basic order for Dutch. In his (1994) paper, he adopts the LCA assumptions, the universal Spec-Head-Complement and Zwart’s (1993) analysis of phrase structure for Dutch. He argues that Kayne’s universal VO proposal is correct for Dutch and not incompatible with his earlier argument that Dutch is an SOV language.

hand, while they do have theta roles like NPs, do not have a strong case feature to be checked through Move, so they remain in their base position, i.e. to the right of the verb. Koster's proposal for feature checking of CP complements is what Chomsky (1998) refers to as *Agree*, an operation which establishes a relation (agreement, case-checking) between a lexical item and a feature F in some restricted search space (its *domain*)<sup>19</sup>. This analysis produces the tree in (25b) for the sentence in (25a):

- (25) a. āraš midune [ke bābā-š dars mixune]  
*Arash knows that dad-his lesson studies*  
 "Arash knows that his dad studies."

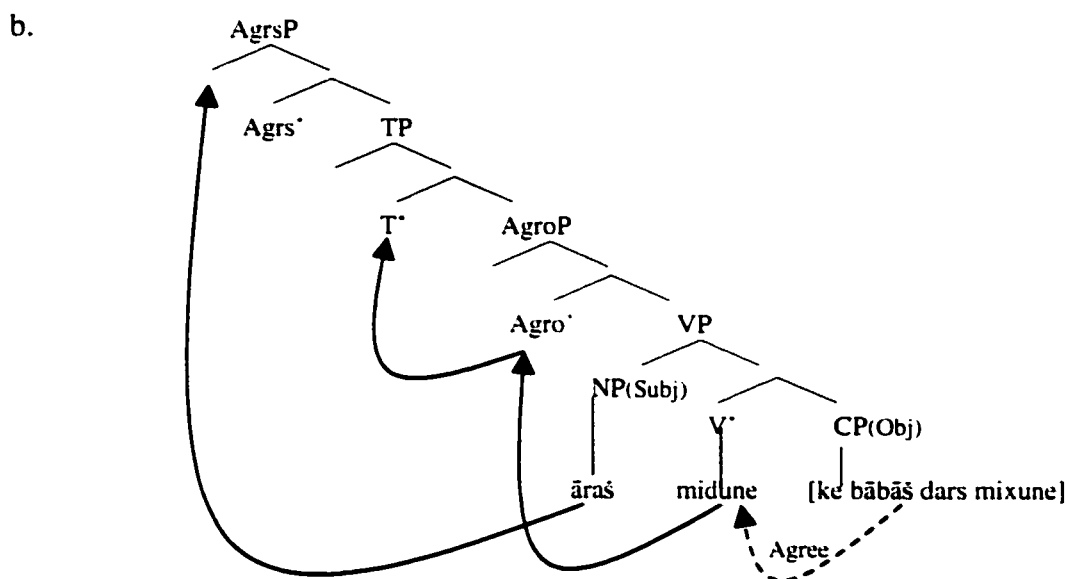

As in (21, 23), in order to check its nominative feature and under the influence of EPP, Subj raises to Spec AgrsP without any violation of MLC. In the second step, head-complement agreement checks the features of the CP complement in-situ with V\* under the operation *Agree*. In the last step, head-to-head movement raises V\* to Agro' and then to T\*, and the SVO order as the only order when the complement of V\* is a CP is realized.

<sup>19</sup> Chomsky (1998): p.14.

The analysis presented in this section completes the investigation of the structure of the functional category IP, splitting it into three maximal projections AgrsP, TP and AgroP. As (21), (23) and (25) indicate, Persian functional categories above VP all show a head-initial configuration. In all of them, the head merges with its complement to the right and with its Spec to the left.

Although the discussion of the IP suffices for the purposes of this research which basically investigates the head parameter and phrase structure, an extension of the proposals elaborated here reaffirms the validity and applicability of the analyses. The sentences I analyzed in this section are comprised of the three basic constituents of an IP: that is, Subj, V and Obj. In order to see how the proposals work in case of more complex sentences, I analyze a sentence with a transitive verb which has an IO in addition to the DO. In the study of Dative constructions in 4.5, I followed Larson's (1988, 1990) VP-shell, and proposed a layered VP in which IO is generated as the complement of the lower V', DO as its Spec, and Subj as the Spec of the higher V', as shown in (56) in Chapter 4, repeated here as (26):

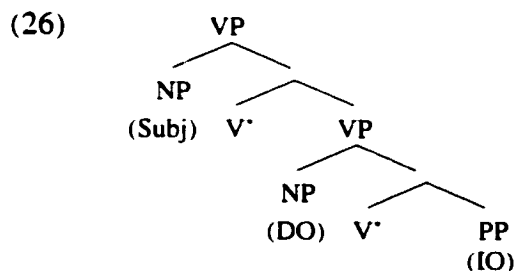

The constituents of the VP move up to check their features against the relevant positions, and build up the IP. Subj raises to Spec AgrsP, Obj raises to Spec AgroP (and in the case of “Stylistic Move” ends up in Spec TP) and V' moves to Agro' and then to T'. As for the landing site of IO for checking its dative feature, I follow Koizumi (1995) and add another functional category in the tree, above AgroP and under TP, and call it AgrioP whose

specifier position checks the features of IO<sup>20</sup>. This analysis brings about the tree in (27b) for the sentence in (27a):

- (27) a. āraš be bābā-š ketāb-o dād. (S IO DO V)  
*Arash to dad-his book-rā gave*  
 "Arash gave the book to his dad."

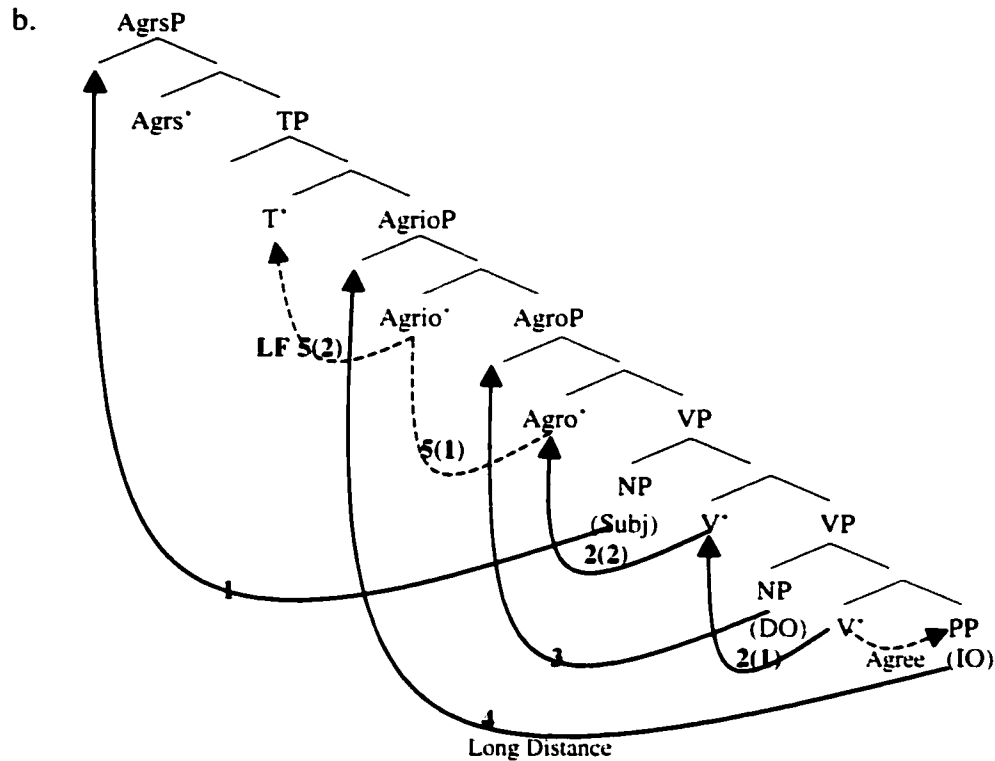

No. (27) is the *more frequent* word order for Persian with the [S IO DO V] order in PF. The feature checking process is done in the following way. Subj moves to Spec AgrsP for checking its nominative feature and under EPP (Move 1). IO checks its dative feature with V<sup>\*</sup> by the operation Agree. Head-to-head movement raises V<sup>\*</sup> to Agro<sup>\*</sup> (Move 2). This movement makes DO equidistant from Spec VP and Spec AgroP that makes raising of DO to the latter possible. Therefore, DO moves to Spec AgroP, checking its accusative feature

<sup>20</sup> Ura (2000) studies double object constructions from another perspective. He investigates this construction under the Agr-less feature-checking theory reinforced with the theory of multiple feature checking.

(Move 3). Then, a *stylistic* operation which has no LF import causes IO to move higher post-spell-out in the PF component (Aoun & Benmamoun 1998:p.570). The landing site of IO will be Spec Agr<sub>IO</sub>P, which obviously violates locality (Move 4). Here, I follow Rivero (1997, 1999) and call this movement a “long distance movement” operating in the PF branch and assume that it is not sensitive to the MLC. This movement which is called “Stylistic Scrambling” is not for the purpose of feature checking but for *positional* or *word order* considerations or as Aoun & Benmamoun (1998) state, it is driven by *prosodic* considerations (Move 4). In the last step, V\* moves to Agr<sub>IO</sub>\* and ends up in T\* in LF (Move 5). These consecutive Moves whose validity are justified and obey MLC, yield the actual order of the sentence. This PF Move recalls Guéron’s (1980) treatment of PP extraposition. It displaces IO, and puts the V\* to the right edge of the IP. This process flanks the IP with the Subj to the left and the V\* to the right. Perhaps the motivation for this Stylistic Move is placing the Agent at both edges of the clause, which is reminiscent of Chomsky’s suggestion (1995) that stylistic movements may be triggered by information structure needs. An issue I leave unexplored is why V\* stops in Agr\* in this particular case.

No. (27) is not the only order permitted by Persian speakers. DO can precede IO in PF. In this case, there is an extra Move which raises DO to Spec TP (Move 6). This Move bypasses Spec Agr<sub>IO</sub>P. Again, I claim that this movement is an instance of “Long Distance Movement” which does not violate locality as proposed by Rivero (1997, 1999). It is done in PF and is driven by word order considerations. Earlier, I called this kind of movement the “Stylistic Scrambling” and presented the motivation for its existence. No. (28a) is a sentence with the [S DO IO V] order with its tree in (28b).

- (28) a. āraš ketāb-o be bābā-š dād (S DO IO V)  
*Arash book-rā to dad-his gave*  
 "Arash gave the book to his dad."

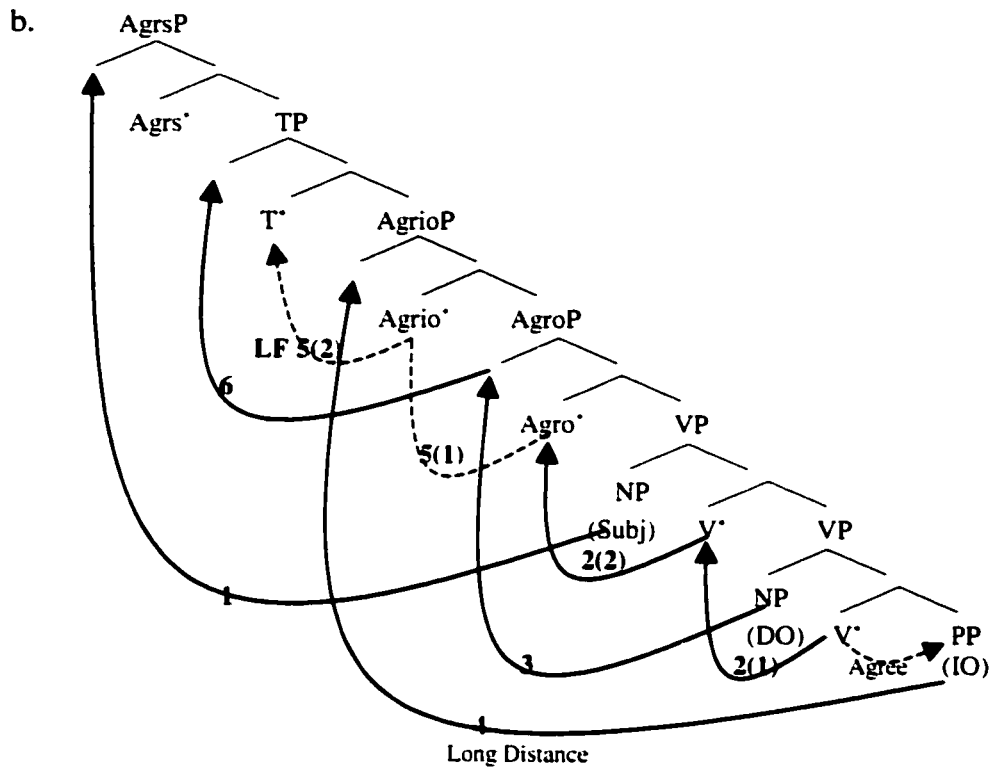

To conclude, Persian sentences in both lexical domain (VP) and functional domain (AgrsP, TP and AgrioP) appear in a strict head-initial configuration underlyingly which supports the universal Spec-Head-Complement for this phrasal category.

## Appendices

### Left Periphery of the Clause (CP & TopP)

In order to complete our investigation into lexical (NP, AP, PP) and functional (DP, IP) categories, I will now examine the maximal projections of CP and TopP. These projections occupy positions above IP in the tree, and are referred to as the “left periphery of the clause” by Rizzi (1997). As in the study of other categories, I examine the applicability of the LCA, and specifically, the Spec-Head-Complement order of these categories.

#### Appendix 1: Persian CPs

Like other Persian XPs, CPs display a unique head-initial configuration. CP is headed by C\*, phonetically realized as *ke* “that” which selects its IP complement to the right. This IP complement is, as previously noted, split into AgrsP, TP and AgroP. The operation Merge places the specifier to the left of C\*, yielding the CP structure shown in (29):

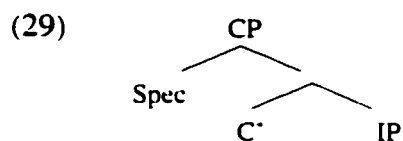

As (29) illustrates, C\* subcategorizes for its complement to the right which gives a head-initial status to this phrase, unlike Japanese in which the complementizer apparently selects its complement to the left<sup>21</sup>. No. (30) compares the head position in Persian and Japanese CPs:

---

<sup>21</sup> Rizzi’s proposal for considering CPs as “left periphery of the clause” is justified under the LCA even for languages like Japanese in which C\* does not stand to the left of the clause (30b). See footnote (22).

(30) a. Persian CP

midun-am [<sub>CP</sub> ke āraš xord sib - o]  
*know - I that Arash ate apple-rā*  
"I know that Arash ate the apple."

b. Japanese CP<sup>22</sup>

wataši-ha [<sub>CP</sub> taro -ga ringo-wo tabeta-nowo] šitteimasu.  
*I - Nom Nom apple-Acc ate - that know*  
"I know that Taro ate the apple."

Apparently, in the Persian CP in (30a), C° selects its IP complement to the right, contrary to the Japanese CP in (30b) in which C° subcategorizes for its complement to the left<sup>23</sup>.

I assume that Spec CP is the landing site for WH-movement in Persian, the process observed in languages such as English<sup>24</sup>. WH-movement is illustrated in (31):

(31) a. ċi-ro xord āraš  
*what-rā ate Arash*  
"What did Arash eat?"

---

<sup>22</sup> Example is from Yoriko Aizu (personal communication).

<sup>23</sup> It is possible to derive the head-final Japanese CP from a head-initial one in which IP originates as the complement of C to its right, and then raises to Spec CP as is tentatively argued by Koizumi (1995), p.202:

a. [<sub>CP</sub> C [<sub>IP</sub> S<sub>i</sub> O<sub>j</sub> V (t<sub>i</sub>)(t<sub>j</sub>) t<sub>j</sub> ] ]  
b. [<sub>CP</sub> [<sub>IP</sub> S<sub>i</sub> O<sub>j</sub> V (t<sub>i</sub>)(t<sub>j</sub>) t<sub>j</sub> ]<sub>k</sub> [C t<sub>k</sub> ] ]

Such analysis supports the LCA assumption that a head invariably precedes its complement.

<sup>24</sup> Bach (1971: p. 161) states that, "interrogative Wh-movement is generally absent from SOV languages". This characteristic can be another piece of evidence supporting the claim that Persian is an SVO language.

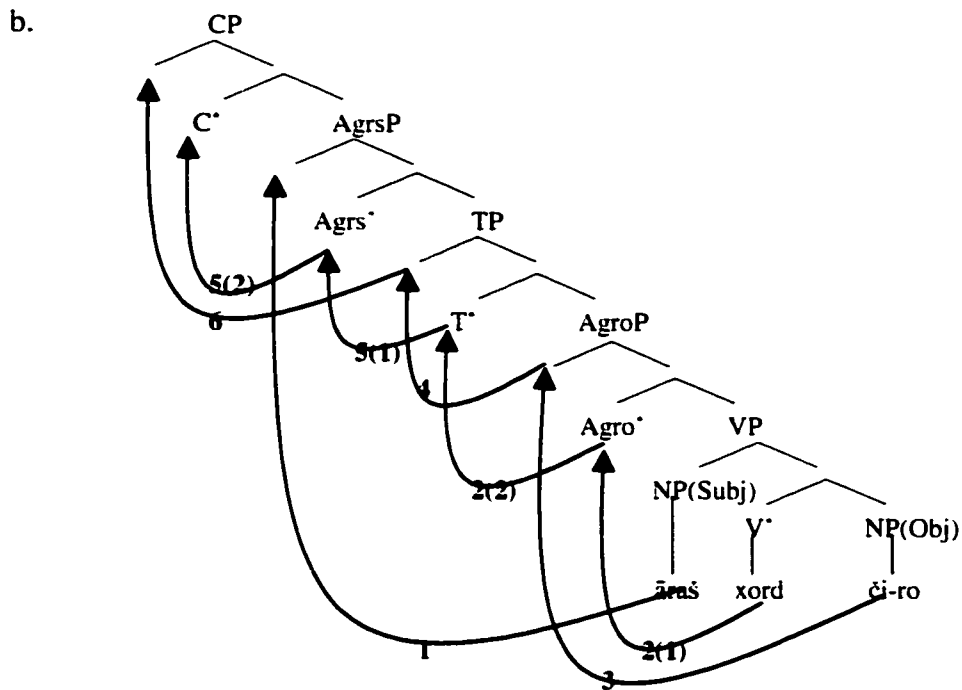

As discussed earlier, in the first step,  $V^*$  selects its complement Obj to the right and its specifier Subj to the left and the VP is built. In the next step, the process of feature checking raises the constituents of the VP to appropriate positions and builds up the sentence in the manner justified before and repeated here. Subj moves to Spec AgrsP for checking its nominative feature and because of EPP. Head-to-head movement raises  $V^*$  to  $Agro^*$  and then to  $T^*$ . The first phase of head movement makes Obj *equidistant* from both Spec VP and Spec AgroP. Obj chooses the second option and moves to Spec AgroP. This Move checks the accusative feature of Obj. Another Move which I justified before and called "Stylistic Move" raises Obj to Spec TP. Then, again, head-to-head movement moves  $V^*$  from  $T^*$  to  $Agrs^*$  and finally to  $C^*$ . Movement of  $V^*$  from  $T^*$  to  $Agrs^*$  makes Obj, which is in Spec TP, *equidistant* from Spec AgrsP and Spec CP. Obj chooses the second option and raises to Spec CP, yielding the WH-question in (31a).

In addition to (31) in which the Wh-phrase moves overtly to Spec CP, Persian allows in-situ Wh-phrases as shown in (32):

- (32) āraš ċi - ro xord?  
*Arash what-rā ate*  
 "What did Arash eat?"

Here, I agree with Hashemipour (1989)<sup>25</sup> and Raghibdoust (1993) that in such cases, the Wh-phrase moves up to Spec CP in LF. Thus No. (32) will have the representation in (33):

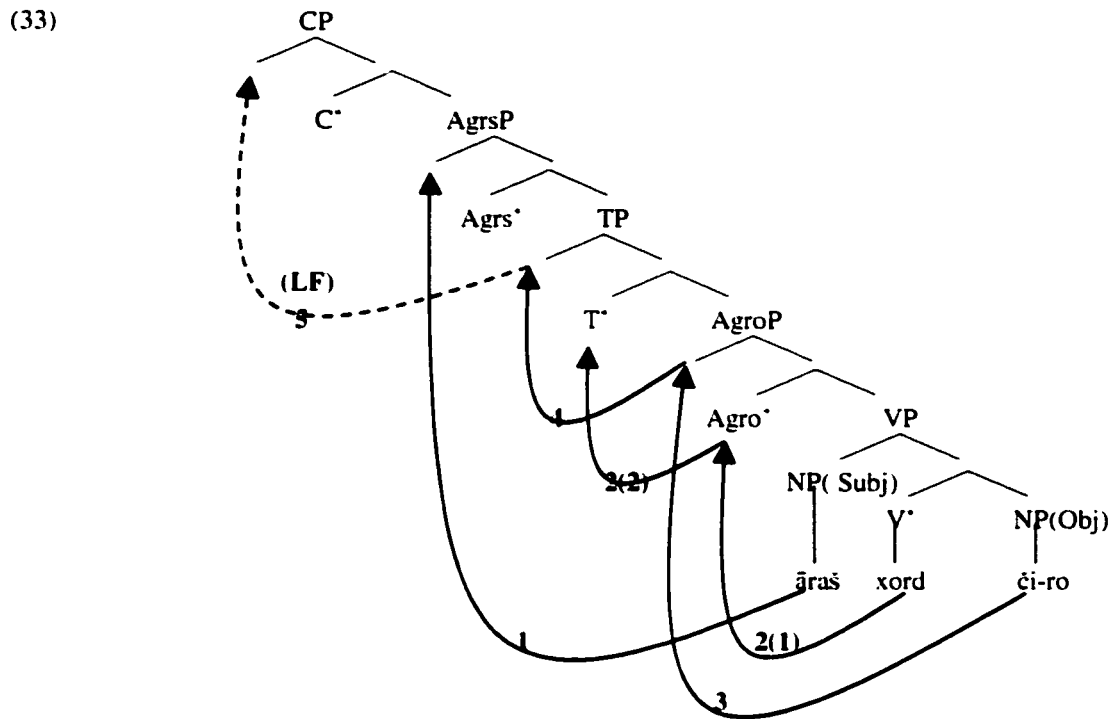

Subj raises to Spec AgrsP. V\* moves to Agro\* and then to T\*. Movement of V\* to Agro\* makes Obj *equidistant* from Spec VP and Spec AgroP. Obj chooses Spec AgroP. Then, the “Stylistic Move” raises Obj to Spec TP. In the last stage, Obj, which is the Wh-phrase, moves to Spec CP in LF and takes scope over the whole clause.

<sup>25</sup> Hashemipour (1989), based on two examples with fronted Wh-phrase which she supposes ungrammatical, concludes that Persian does not have syntactic Wh-movement (p.251). As (31) and (33) show, both LF movement and syntactic movement of Wh-phrases are possible in Persian. Even Raghibdoust (1993) which basically follows Hashemipour’s analysis, states that “Persian is basically a Wh-in-situ language, although its Wh-phrases are free to appear everywhere including initial position in a clause (p.102).

The CP analysis presented in this section showed that this functional category, the highest maximal projection of a sentence, is headed by C°, which may be null, or phonetically realized as *ke* “that”, and subcategorizes for its AgrsP complement to the right. The same head, then, merges with its specifier to the left, and projects to a CP. Spec CP is the landing site for WH-phrase which follows the movement of V\* to C°. To conclude, the survey of CPs showed that this phrasal category is head-initial, a characteristic which makes it compatible with the general Spec-Head-Complement order proposed by the LCA.

## Appendix 2: Topicalization in Persian

In addition to the unmarked word orders SVO and SOV discussed in chapter 4 and also in 5.3, Colloquial Persian displays two other word orders with special meanings. In this section, those orders will be introduced, and an analysis compatible with the theoretical assumptions of this research will be presented. These two orders with their relevant interpretation are illustrated in (34, 35):

(34) *OSV* Focused Interpretation

sib-o āraš xord. (na portāqāl-ro)  
*apple-rā Arash ate not orange - rā*  
 “Arash ate the apple.” (not the orange)

(35) *VSO*

a. Emphatic Interpretation

xord āraš sib-o.  
*ate Arash sib-rā*  
 “Arash did eat the apple.”

b. Interrogative Interpretation

xord āraš sib-o  
*ate Arash apple-rā*  
 “Did Arash eat the apple?”

In (34), the focused constituent is Obj which has moved from its unmarked position inside IP to the leftmost periphery of the clause, giving an OSV order to the sentence. The reason for the fronting of this element is to emphasize or focus it by contrasting it with another potential alternative like *portāqāl* “orange”. This process which moves a constituent of the IP to a position above it is normally referred to as Focalization or Topicalization and gives an emphatic interpretation to the focused phrase. In (35), instead of a phrase, a head has been raised from inside IP to a head position above IP, yielding a VSO order for the sentence. In Persian, the fronting of V’ to a potential focused head above IP would have two reasons. First, V’ moves in order to emphasize the action done by the verb as in (35a), which is a case of Emphatic Interpretation. The movement of V’ can also change a declarative sentence to a question as in (35b), which is an instance of Interrogative Interpretation.

My analysis for *Topicalization/ Focalization* in Persian is based on Ouhalla’s (1992) analysis of this phenomenon in classical Arabic, in which he proposes a structure like (36) where the clausal domain is dominated by a functional projection FP, Focus Phrase, whose head contains the head marking focus<sup>26</sup>:

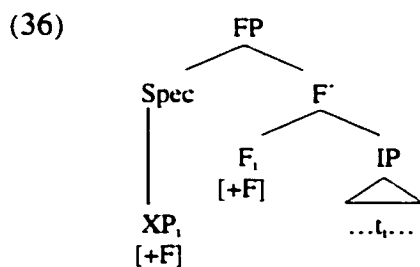

<sup>26</sup> Haegeman (1994): p.603-4.

Following Ouhalla, I propose that in (34) and (35) where a constituent is fronted as a case of Topicalization, a Topic Phrase (TopP) dominates IP, in a manner that the head of TopP subcategorizes for AgrsP to its right and its Spec to the left. In the OSV example in (34), Obj moves to Spec TopP, for Emphatic interpretation. In the VSO examples in (35), V' moves to Top', giving an Emphatic Interpretation to (35a) and an Interrogative Interpretation to (35b)<sup>27</sup>. No. (37) illustrates the procedure that produces the sentence in (34):

(37) OSV

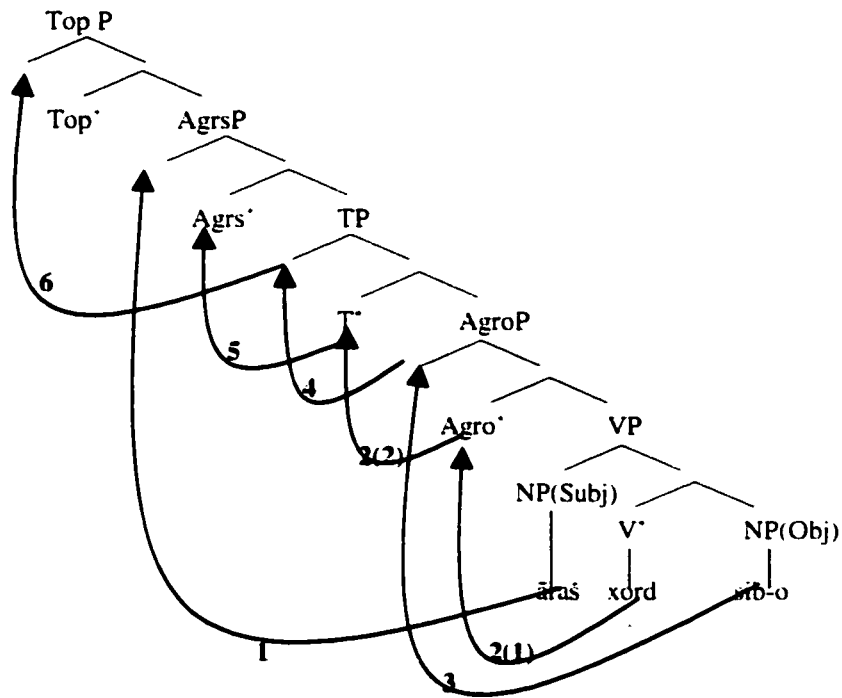

In (37), Subj moves from Spec VP to Spec AgrsP. V' moves to Agro' and then to T'. Move 2(1) making Obj *equidistant* from Spec VP and Spec AgroP, raises it to Spec AgroP. Move 4 is the "Stylistic Move" which carries Obj from Spec AgroP to Spec TP. Move 5 raises V'

<sup>27</sup> The intonation of the sentence determines if Topicalization in (35) is for Emphatic Interpretation or Interrogative Interpretation.

from T\* to Agrs\*. Again, this head movement makes Obj in Spec TP *equidistant* from Spec AgrsP and Spec CP. Obj raises to the highest available position in Spec CP. These consecutive Moves produce the OSV order of the sentence in (34).

Now, look at the movements that put the verb in the focus position of the sentence, as in (38):

(38) VSO

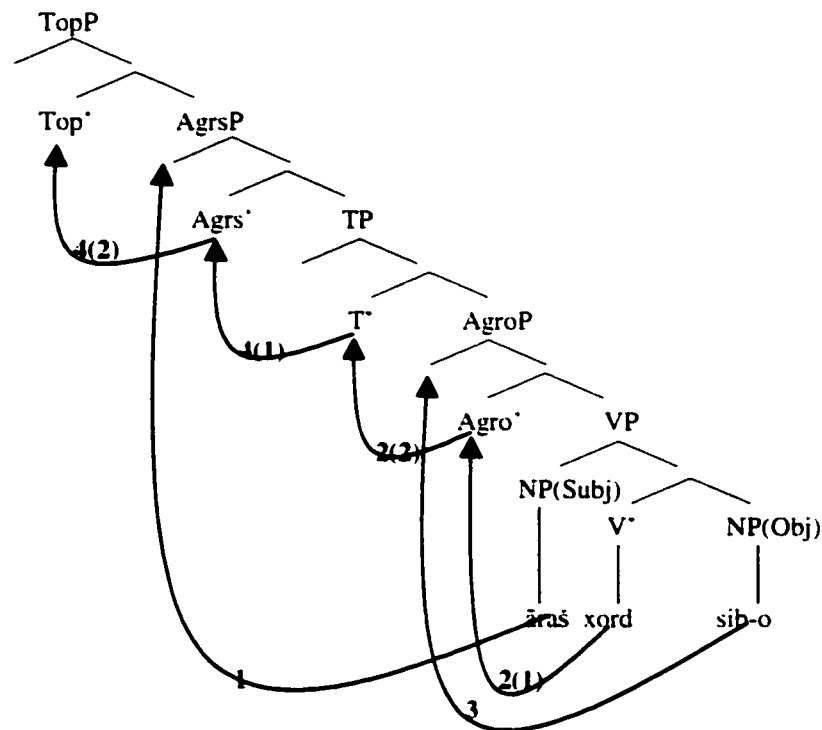

Move 1 raises Subj from Spec VP to Spec AgrsP. Head-to-head movement raises V\* to Agro\* and then to T\* (Move 2). Move 2(1) makes Obj *equidistant* from Spec VP and Spec AgrsP. Obj chooses the second option and lands in Spec AgroP. Then, V\* in T\* moves to the highest head, crossing Agrs\*, and ending up in Top\* to produce the VSO order of the sentences in (35).

To sum up, the analysis of the two different manifestations of Topicalization showed that TopP, similar to CP is indeed a head initial category located in the left periphery of the

clause. This finding indicates that TopP is headed by Top' which selects AgrsP to its right as its complement and merges with its Spec to the left.

## **Chapter 6**

### **Diachronic Study of Persian Phrase Structure**

This chapter surveys phrase structure in the earlier stages of Persian. Following a brief history of the language, I investigate the phrasal categories of NP, AP, PP, VP and IP as well as the phenomenon of “Topicalization” in Old Persian and in Middle Persian.

#### **6.1 Introduction**

In the previous chapters, I presented a comprehensive analysis of the phrase structure and phrasal categories of Standard Colloquial Persian as it is spoken today. Inclusion of a diachronic study of Persian phrase structure provides insight into the historical development of the phrasal categories that I have thus far analyzed synchronically. Standard Colloquial Persian developed from the Indo-European language of the immigrants who moved from Southern Russia to the southwest of the Persian Plateau about 1000 B.C. They called their occupied lands the land of Eras or Aryans. Their distinctly Aryan language has been preserved since then, even following the Arab invasion in the seventh century.

The Persian language is called *Fārsi* or *Pārsi* in the more literary form in Iran, *Dari* in Afghanistan, and *Tājiki* in Tajikistan. It is divisible on a chronological basis into three periods: Old Persian, Middle Persian, and Modern Persian. Studies of Old Persian are based on cuneiform inscriptional texts, preserved from the time that the language was spoken, and studies of Middle Persian are based on some rock-inscriptions of the kings together with a number of written religious texts of Iranian Christians and Zoroastrians.

## **6.2 Old Persian (1000-300 B.C.)**

Old Persian, the language of southwest Persia, was the vernacular speech of the Achaemenian Empire. Linguistically, Old Persian belongs to the Iranian branch of Indo-Iranian or Aryan, which is one of the main divisions of the Indo-European family. Old Persian is known by cuneiform inscripational texts of the Achaemenian dynasty found in different parts of Iran. This language was a highly inflected language with eight cases (nominative, accusative, dative, genitive, ablative, locative, instrumental, and vocative), three genders (masculine, feminine and neutral) and a dual form in addition to the singular and plural.

### **6.2.1 Noun Phrases in Old Persian**

In chapter 3, I argued in favor of the DP Hypothesis for Standard Colloquial Persian based on theoretical foundations and existing evidence, and showed that Persian nominal phrases should be treated as DPs. DP is headed by *e*, *i*, or  $\emptyset$  which selects an NP as its complement to the right or another EzP, and a QP or DemP or NumP as its Spec to the left. The NP complement, in turn, subcategorizes for an EzP as its complement to the right, and an AP as its Spec to the left (look at the tree diagrams No. 34, 37 and 43-50 in chapter 3). Also, it was discussed that EzP regulates the occurrence of multi-complement N<sup>o</sup>, head of NP. Due to the lack of elements that we considered as the head of DP in Old Persian, it is not justifiable to follow the DP Hypothesis for this period of Persian<sup>1</sup>. Thus, it would be more

---

<sup>1</sup> Even for the non-colloquial register of Modern Persian, a DP analysis should be tackled cautiously. It should be mentioned that there is no discussion in the literature about the time that Persian NPs developed to DPs.

appropriate to stick to the customary NP analysis for the oldest stage of Persian. As any NP, Old Persian NPs are headed by N'. Some elements precede N' and others follow it. In the analysis of Modern Persian DPs, we observed that Spec DP is filled with a QP or DemP or NumP, and Spec NP is filled with an AP, that is, they are the elements that precede N'. Interestingly, in Old Persian, N' is preceded by one of these XPs as shown in (1):

- (1) a. *imā dahyāva* (Kent 1953: DB1.21 p.117)  
*these lands*  
 "these countries"
- b. *aiva martiya* (Kent 1953: DB1.36 p.117)  
*one man*  
 "a man"
- c. *pārsa martiya* (Kent 1953: DNa.46 p.137)  
*Persian man*  
 "a Persian man"

In the NP (1a), the N' *dahyāva* "lands" is preceded by *imā* "these" which is a demonstrative. In (1b), the N' *martiya* "man" is preceded by *aiva* "one", which is a numeral. In (1c), the head noun *martiya* "man" is preceded by the adjective *pārsa* "Persian". Considering the fact that the element preceding N' is either a demonstrative or numeral or an adjective, and in conformity with the analysis proposed for Modern Persian nominal phrases, I propose that in Old Persian, NPs are headed by N' preceded by a DemP or NumP or AP to their left in their Spec. This leads us to a tree diagram for Old Persian NPs as (2):

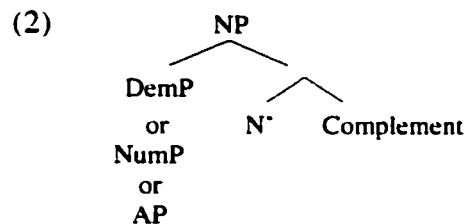

This configuration produces (3a) and (3b) for (1a) and (1c):

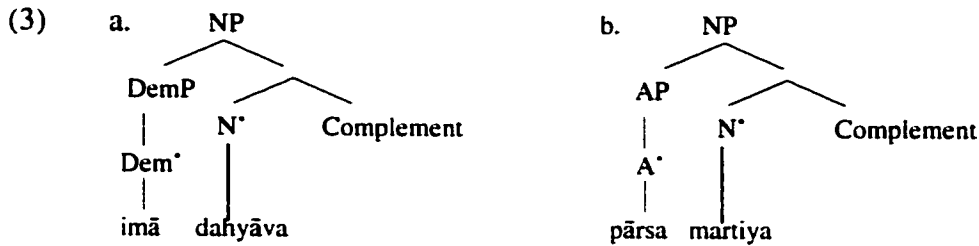

Elements that occupy the complement position of N', are shown in (4):

- (4) a. *kāra hya manā*<sup>2</sup> (Kent 1953: DB2. 55 p.122)  
*army Ez I*  
 "the army of mine"
- b. *kāra māda* (Kent 1953: DB2. 16 p.12)  
*army median*  
 "the Median Army"

As (4) displays, the complement of N' appears in a configuration similar to the one proposed for Modern Persian; that is, the EzP regulates the occurrence of post-N' elements in an NP which we consider the complements of N'. This proposal yields (5) as the equivalent trees for (4):

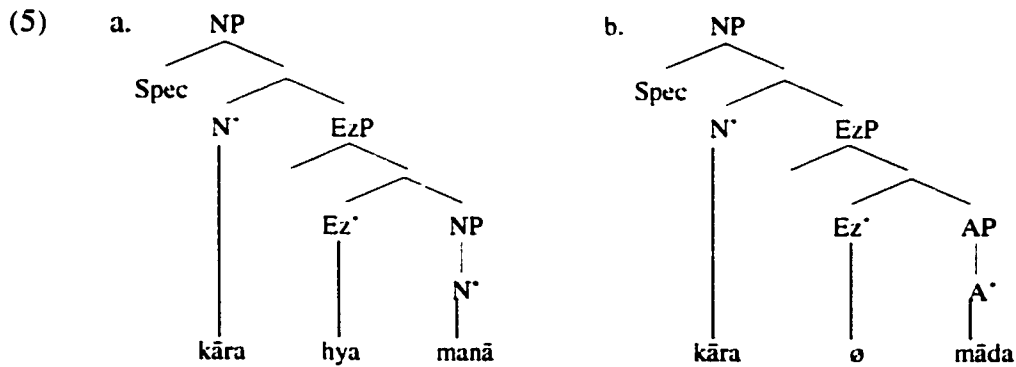

<sup>2</sup> Enclisis is a frequent phenomenon in Old Persian which can be seen in pronouns, coordinating conjunctions, postpositions, adverbs, particles and so on. Due to its complex structure and lack of relevant analysis for this phenomenon in the literature, it was not surveyed here. Recall that the absence of clitics from the investigation of this period of Persian does not affect the basic trend of this study. The role of clitics in Modern Persian DPs is shown in chapter 3, No. 49.



- (8) a. hamičiya hača kabūjiyā (Kent 1953: DBI. 40 p. 117)  
*rebellious from Cambyses*  
*“rebellious from Cambyses”*
- b. hačāma hamičiya (Kent 1953: DBI. 40 p.117)  
*from-me rebellious*  
*“rebellious from me”*

In (8a), the complement *hača kabūjiyā* “from Cambyses” is selected by the A\* *hamičiya* “rebellious” to its right; but in (8b), the complement *hačāma* “from me” appears to the left of the same head A\*. This variation suggests either that Old Persian APs sometimes select their complement to the right and sometimes to the left, or that some kind of movement is involved. The limited available data on Old Persian together with the structure of APs in Modern Persian favor a movement analysis. I consider Spec AP in Old Persian to be the landing site for the PP, complement of A\*. The outcome of this process is illustrated in (9):

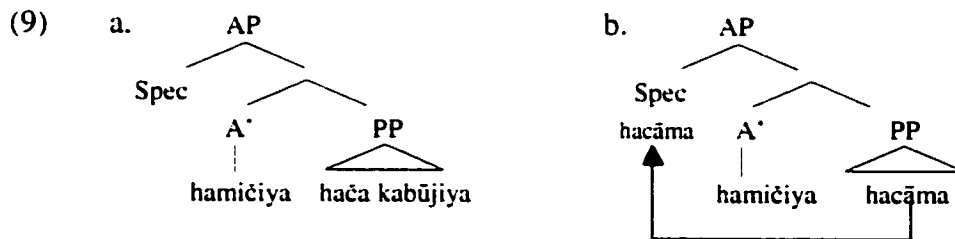

Thus, APs in Old Persian, as in Modern Persian, are head-initial, with the order [PP A\* ] being analyzed as the result of movement which carries the complement to the specifier position of AP.

### 6.2.3 Old Persian PPs

Old Persian uses both prepositions and postpositions. As listed in (10), out of the 22 adpositions found in the texts, there are 18 prepositions, 2 postpositions, and 2 adpositions which can be used either as pre- or postposition:

(10) List of Adpositions in Old Persian

A. PREPOSITIONS (18)

|                                            |                              |                                      |                                 |
|--------------------------------------------|------------------------------|--------------------------------------|---------------------------------|
| 1. <i>ā</i> "to"                           | 5. <i>abiy</i> "to, against" | 10. <i>nidadiy</i> "on the track of" | 15. <i>pasā</i> "after"         |
| 2. <i>atar</i> "within, among"             | 6. <i>upā</i> "toward"       | 11. <i>pašiyā</i> "before"           | 16. <i>yātā</i> "unto"/ "until" |
| 3. <i>aθiy</i> "to"                        | 7. <i>upariy</i> "above"     | 12. <i>patiš</i> "against"           | 17. <i>hačā</i> "from"          |
| 4. <i>anvu (anu)</i> "along, according to" | 8. <i>tara</i> "through"     | 13. <i>para</i> "beyond"             | 18. <i>hadā</i> "with"          |
|                                            | 9. <i>ni</i> "down"          | 14. <i>pariy</i> "around, about"     |                                 |

B. POSTPOSITIONS (2)

1. *parā* "along"      2. *rādiy* "on account of"

C. ADPOSITIONS USED AS BOTH PREPOSITIONS OR POSTPOSITIONS (2)

1. *patiy* "against, on"      2. *ā* "to"

Examples of head-initial prepositional phrases are found in (11), while (12) provides an instance of an adposition used as a postposition:

- (11) [<sub>PP</sub> *hačā sakaibiš tyaiy para sugdam*] *amata* [<sub>PP</sub> *yātā ā kūša*]  
*from Scythians that beyond Sogdiana thence until to Ethiopia*  
"from the scythians who are beyond Sogdiana, thence into Ethiopia."  
(Kent 1953: DPh. 5-6 p.136)

- (12) [<sub>PP</sub> *θūravāharahyā māhyā jiyamnam patiy*] (Kent 1953: DB2. 61-2 p.122)  
*Thuravahara month end on*  
"on the last day of the month Thuravahara"

Three observations suggest the Old Persian postpositions in fact head PPs that are head-initial. First, it is possible that in (12), the adposition *patiy* "on" has been postposed to rhyme with *vasiy* "greatly" in the previous clause which is given in No.(13):

- (13) *kāra hya manā avam kāram tyam<sup>3</sup> hamičiyam aja vasiy*  
*army Ez I that army that rebellious smote greatly*  
 “My army smote that rebellious army exceedingly.” (Kent 1953: DB2. 60-1 p.122)

Secondly, postpositions are normally used as enclitic postpositions denoting the grammatical case of NPs to which they are attached<sup>4</sup>; and finally, as previously mentioned, 80% of adpositions are solely used as prepositions, and of the remaining 20%, only 10% are used exclusively as postpositions, and 10% overlap. Therefore, in the absence of an independent argument in favor of the head-final status for PPs in Old Persian, and in accordance with the general assumptions of this research, I propose that Old Persian PPs are head-initial. To account for the head-final PPs, I assume that the NP complements of head-final PPs are raised from complement position to Spec PP, yielding a PF head-final PP, as shown in (14):

- (14) [PP [NP]<sub>i</sub> P' t<sub>i</sub>]

#### 6.2.4 VP in Old Persian

Although word order is quite free in Old Persian, in both root clauses and subordinate clauses, the normal order is SOV as shown in (15):

- (15) *kāra hya naditabairahyā Tigrām adāraya* (Kent 1953: DB1. 85 p.118)  
*army Ez Nidintu-Bel Tigris held*  
 “The army of Nidintu-Bel held the Tigris.”

<sup>3</sup> In the NP *avam kāram tyam hamičiyam* “that rebellious army”, the suffixal accusative marker *am* is found on all four members of the NP. In this NP, *tyam* which is normally a relative pronoun, is used as *Ez*’, carrying the same function as *hya* “Ez” in the NP *kāra hya manā* “my army” in the subject position of the sentence. In other words, *tyam* “that” establishes the relationship between the N’ *kāram* “army” and its modifying adjective *hamičiyam* “rebellious”.

<sup>4</sup> The postposition *rādīy* is a good example which represents the accusative case. The famous direct object marker *rā* in Modern Persian is the simplified form of this postposition.

However, the occurrence of head-initial VPs (without specific reading) suggests that both OV and VO orders are possible in Old Persian. An instance of the VO order is found in (16):

- (16) adam jadyāmiy auramazdām                      (Kent 1953: DPd. 20-2 p.136)  
      I     ask            Ahuramazda  
      *"I beg of Ahuramazda."*

Similar to Modern Persian, the *more frequent*<sup>5</sup> word order is SOV, which seems to support underlying head-final status for VPs. In Old Persian, there is no sign of post-verbal CP-complements, clitics, or intervening V-complement adverbs, the type of evidence I presented to support an underlying SVO order for Colloquial Persian. This lack of evidence supports a verb-final analysis for VPs in Old Persian, as an analysis found in Kent (1953). However, in spite of the free word order of Old Persian, a head-initial analysis for Old Persian VPs is not only possible but preferable, since it gives harmony to the analysis of VPs in Old Persian and in Modern Persian. To put it in other words, a head-initial analysis does no worse than a head-final analysis for Old Persian. This line of reasoning has been applied by Roberts (1997) in his study of word order change in English where he states that it is possible to give a head-initial analysis to Old English VPs even though the object precedes the verb. He claims the OV order found in Old English is derived by leftward movement, making the head parameter consistent across phrasal categories. Considering these facts, I propose analyzing Old Persian VPs in the manner I proposed for the VPs of Modern Persian. That is, V\* subcategorizes for its complement Obj to the right, and its Spec Subj to the left, yielding the SVO order, illustrated by the configuration (17):

---

<sup>5</sup> Recall that I draw a distinction between the *more frequent* word order and the *basic* word order.

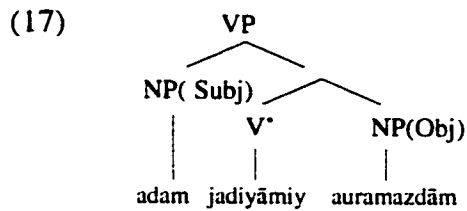

No. (17) is the underlying structure of a VP in Old Persian, and orders like SOV are derived by some kind of leftward movement. Other word orders and the processes which build up a sentence with different orders will be discussed in the next subsection.

### 6.2.5 Old Persian Sentences

Verb phrases in Old Persian can be analyzed in a manner in which V\* selects its complement Obj to the right and its Spec Subj to the left and projects to VP. These elements are directly chosen from the lexicon and carry their relevant features. Later, in the process of sentence formation, these features will be checked in the appropriate slots in the functional categories dominating VP and produce the sentence, which is labeled IP. The functional category IP which is actually broken into three other functional categories AgrsP, TP and AgroP following the Infl-Split Hypothesis, shows an apparent head-initial configuration in Old Persian. AgrsP selects TP as its complement to the right and then TP selects AgroP as its complement to the right and at last AgroP subcategorizes for VP as its complement to its right, yielding (18):

(18) [AgrsP [TP [AgroP VP]]]

The feature checking process in Old Persian is done in the way that was explained for Modern Persian in 5.3. At first, Subj raises from Spec VP to Spec AgrsP for checking its nominative feature and because of EPP. As discussed in the analysis of feature checking in

Modern Persian, this Move does not violate MLC. In the next step, head-to-head movement carries V\* to Agro\* and finally to T\*. The first phase of this Move, V\*-to-Agro\*, makes Obj *equidistant* from both Spec VP and Spec AgroP. Then Obj crosses Spec VP and lands in Spec AgroP without violation of the Shortest Move, and checks its accusative feature. These Moves bring about a sentence with an SVO order which we called the *basic* word order for Persian. The feature checking process for the sentence in (16) is shown in (19):

(19) SVO: The Basic Order

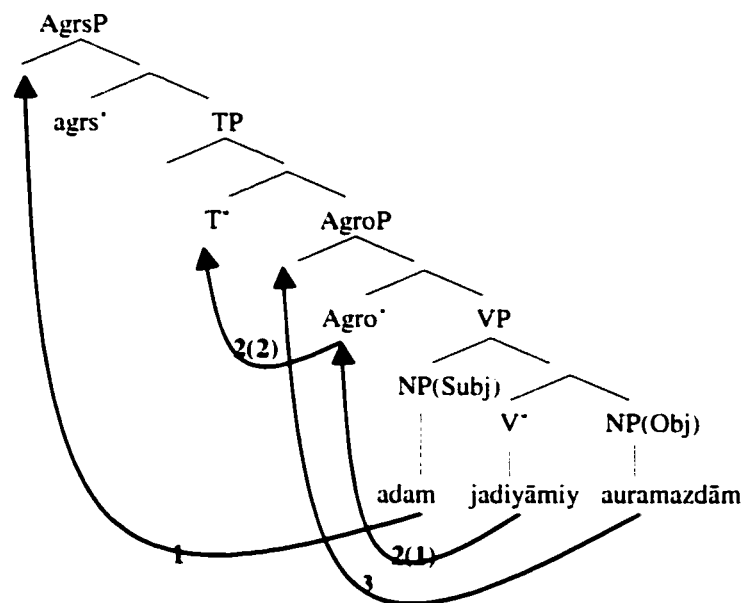

In my analysis of Modern Persian IPs, I introduced the idea of “Stylistic Move” which creates a sentence with SOV order, the *more frequent* word order in (Modern and Old) Persian. Therefore, the sentence in (15) is founded by the Moves in (20):

(20) SOV: The More Frequent Order

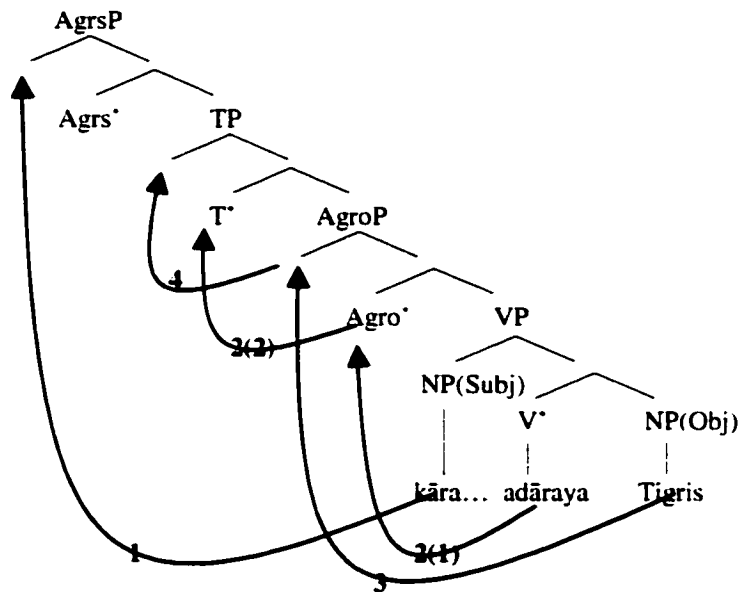

In addition to the SVO word order, which I categorize as the *basic* word order, and the *more frequent* SOV word order, two manifestations of Topicalization, VS and OSV orders are also observed. No. (21) is a case of VS order and No. (22) is a case of OSV:

(21) *Ēātiy dārayavauš xšāyaθiya* (Kent 1953: DBI.34 p.116)  
*saith Darius king*  
 "Saith Darius the king."

(22) *xšačam hauv agarbāyatā* (Kent 1953: DBI.41 p.117)  
*sovereignty he seized*  
 "The sovereignty he seized."

The analysis of Topicalization in Modern Persian in appendix 2 of Chapter 5 supposes a functional category TopP dominating AgrsP in which the topicalized elements check their relevant features in its head or its Spec. I extend this analysis to cases of topicalization in Old Persian, and propose that in (21), the V' *ēātiy* "saith" ends up in Top', and in (22), the Obj *xšačam* "sovereignty" ends up in Spec TopP, giving the intended topicalized interpretation to these sentences. This analysis yields (23) for (22):

(23)

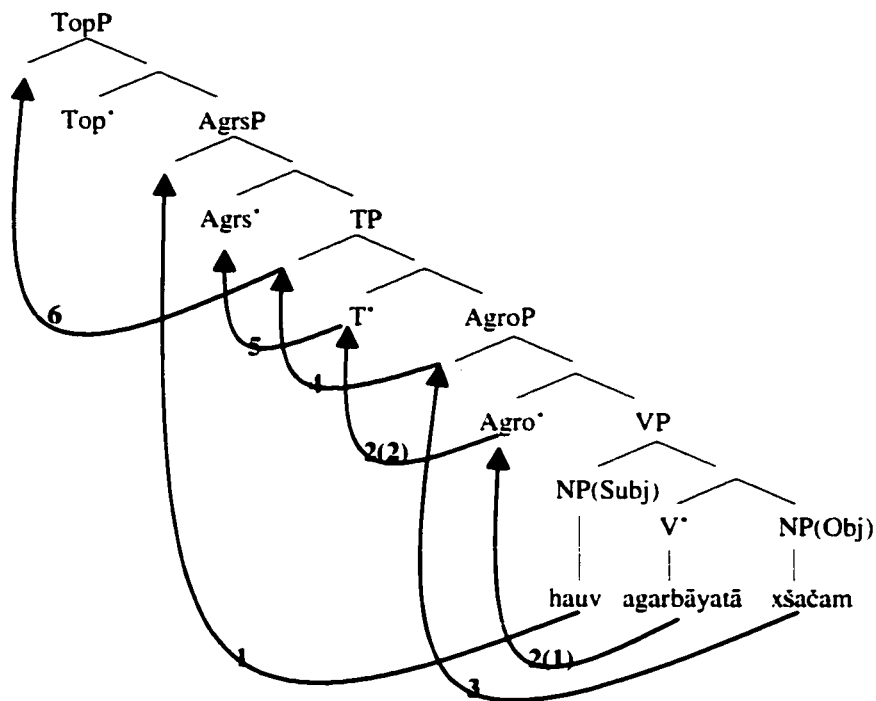

In (23),  $V^*$  selects its complement Obj to the right and its Spec Subj to the left. The process of feature checking moves the constituents of the VP to the relevant positions in the functional domain, yielding the PF realization of the sentence as discussed earlier. Subj raises to Spec AgrsP,  $V^*$  moves to Agro' and then to T'.  $V^*$ -to-Agro' movement makes Obj *equidistant* from Spec VP and Spec AgroP. Obj chooses the latter and raises to Spec AgroP. Movement of Subj checks its nominative feature, and movement of Obj checks its accusative feature. The "Stylistic Move" raises Obj from Spec AgroP to Spec TP. These Moves establish the *more frequent* SOV order for the sentence. In addition to the accusative feature of Obj which was checked in Spec AgroP, and the "Stylistic Move" which raised Obj to Spec TP, there is another feature in Obj which necessitates another Move: a focus interpretation. Again, head-to-head movement makes this raising possible:  $V^*$ , which is in T', moves to Agrs', making Obj, now in Spec TP, *equidistant* from Spec AgrsP and Spec TopP. Thus, Obj moves to Spec TopP and the OSV order of the sentence is realized. For

verb topicalization (21), I follow the analysis I proposed for Modern Persian in chapter 5, (No. 38).

### 6.2.6 CP in Old Persian

CPs in Old Persian appear in a head-initial configuration as the following examples illustrate:

(24) utā [tya būmiš akaniya fravata] utā [tya θika avaniya]  
*and that earth dig/passive downward and that rubble pack down/passive*

utā [tya ištiš ajaniya] kāra hya Bābiruviya hauv akunauš  
*and that sun-dried brick mold/passive people Ez Babylon this did*  
 (Kent 1953: DSf. 28 p.142)

“and that the earth was dug downward, and that the rubble was packed down, and that the sun-dried brick was molded, the Babylonian people-it did(these tasks)”.

(25) avahyarādiy kāram avājaniyā mātyamām xšnātiy [tya adam naiy bardiya kūrauš puca]  
*for this reason people(acc) slay lest, that not know that I not Smerdis Cyrus son*  
 “For this reason, he would slay the people-lest they know me, that I’m not Smerdis,  
 the son of Cyprus.” [Kent 1953 DB1. 52-3 p.117]

As (24) and (25) show, in Old Persian, C<sup>\*</sup> subcategorizes for its complement to the right in the following form:

(26) [CP C<sup>\*</sup> IP]<sup>6</sup>

### 6.2.7 Summary of the Analysis of Old Persian Phrasal Categories

Our investigation of different functional and lexical categories in Old Persian showed that these categories basically appear in the configuration observed in Modern Persian. The

---

<sup>6</sup> WH-movement is not analyzed as question formation is not found in Old Persian texts.

analyses of NPs, VPs, IPs and CPs in Old Persian were completely compatible with the analyses proposed for the same categories in Modern Persian. In the two categories AP and PP, a clear distinction was observed between Old Persian and Modern Persian. While in Modern Persian, they are exclusively head-initial, in Old Persian both Head-Complement and Complement-Head configurations are observed in these two categories. In spite of this variation, it is both possible and desirable to consider Old Persian a consistent S-H-C language if we analyze the Complement-Head cases of APs and PPs to be the result of some kind of Move.

### **6.3 Middle Persian (300 B.C.- 900 A.D.)**

The Middle Iranian language, which includes the Iranian dialects as they appear from about the third century B.C. to the ninth century A.D., is in general called Pahlavi. Pahlavi is a derivation of the Old Persian word *parθava* "Parthian". The two main dialects of Pahlavi are Arsacid Pahlavi which was the official language of the Arsacid dynasty of Parthia, which ruled from 250 B.C. to 226 A.D., and the Sasanian or southwest Pahlavi which was the official language of the Sasanian dynasty, which ruled from 226 A.D. until the invasion of Arabs in 625 A.D. The Sasanian Pahlavi or as it is normally called "Middle Persian" appears to have developed from Old Persian. Unlike Old Persian, Middle Persian shows a strong tendency towards simplification. It has neither gender, nor case, nor dual number. These features make Middle Persian look like Modern Persian more than Old Persian. Considering phrase structure and especially the head parameter, Middle Persian basically exhibits the same characteristics as Old Persian, although some reorderings have been observed in the extant remains.

### 6.3.1 Middle Persian Nominal Phrases

Exactly the same argumentation which lead us to analyze nominal phrases in Old Persian as NPs rather than DPs applies to Middle Persian. Based on the discussion presented in 6.2.1, and considering the peculiarities of noun phrases in Middle Persian, the configuration in No. (6) presented earlier and repeated here as (27) portrays an NP for this period of this language:

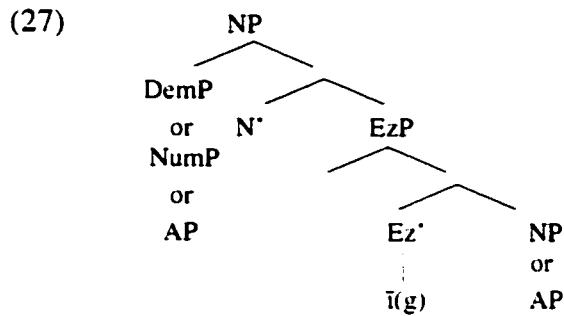

That is, N' subcategorizes for its complement an EzP to the right. Then, it merges with its Spec to the left and projects the NP. Instances of sentences where Spec NP is filled with a DemP or AP or NumP are shown in (28):

- (28) a. ān kanizag (Abolghassemi 1996b: p.224)  
*that girl*  
 "that girl"
- b. wuzurg šadīft (Abolghassemi 1996b: p.136)  
*great joy*  
 "great joy"
- c. sih sad sāl (Abolghassemi 1996b: p.194)  
*three hundred year*  
 "three hundred years"

The complement of N' necessarily follows it as an EzP illustrated in (29):

- (29) a. pādixšay-e ī nog (Abolghassemi 1996b: p.227)  
*kingdom Ez new*  
 "a new kingdom"

b. marg ī alaksadar  
*death Ez Alexander*  
 "Alexander's death"

(Abolghassemi 1996b: p.227)

The Middle Persian NPs in (28) and (29) show that the N' can be modified by either Spec to the left or complement to the right. As in Old Persian and Modern Persian, the complement of N' appears to its right as an EzP. EzP is headed by *ī(g)* which selects its complement to the right as an NP or AP. Applying the structure of (27) to the sentences in (29) gives the trees shown in (30):

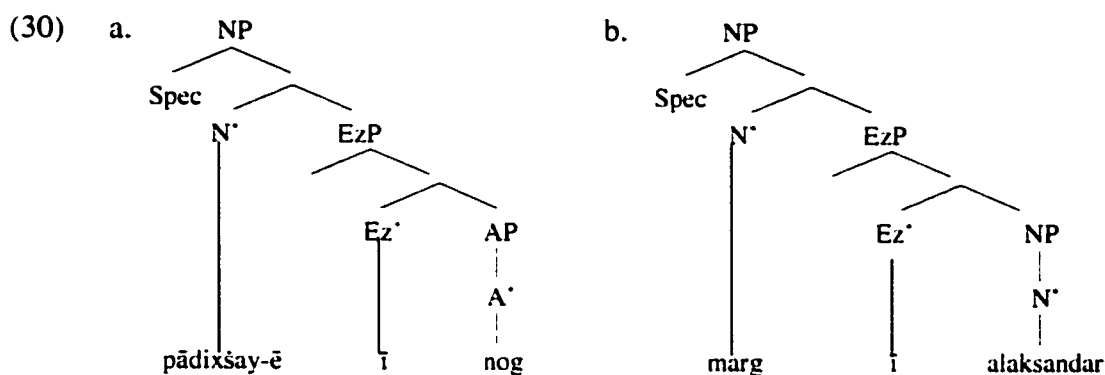

In addition to (29b) and its tree in (30b) where an NP is the complement of N' to its right, there is a case where N' is modified by another noun which precedes it as shown in (31):

(31) axtarmārān sālār  
*astrologers chief*  
 "the chief of astrologers"

(Abolghassemi 1996b: p.227)

I propose that in (31), the noun *axtarmārān* "astrologers" originates as the complement of N' in an Ezafe construction, and then moves to Spec NP, yielding the PF realization of the NP.

This process is displayed in (32):

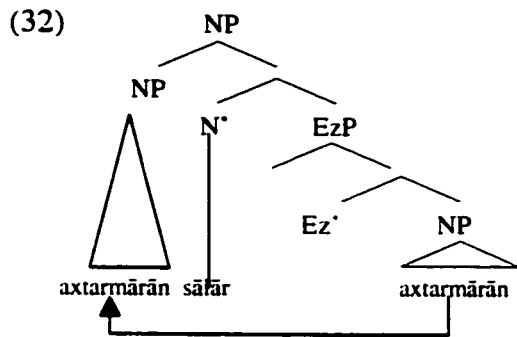

To conclude, the analysis presented in this subsection for NPs in Middle Persian indicates that this category is head-initial. This feature is the same as the feature obtained in the analysis of NPs in Old and Modern Persian.

### 6.3.2 AP in Middle Persian

In Middle Persian, APs have the following structure:

- (33) *yazišnōmand*    *ō*    *axwān*    (Abolghassemi 1996b: p.176)  
*worshipful*    *for*    *existence*  
 “worshipful of existence”

As (33) shows, the adjective *yazišnōmand* “worshipful”, which is the head of the AP, subcategorizes for its PP complement to the right which gives a head-initial configuration to this AP. As the texts indicate, this phrasal category in Middle Persian has lost its Old Persian alternative where the complement could precede the adjectival head.

### 6.3.3 PP in Middle Persian

Prepositional phrases in Middle Persian like those of Old Persian may be both head-initial or head-final, as shown in (34):

- (34) a. *xwad*    *abāg*    (Abolghassemi 1996a: p.227)  
*self*    *with*  
 “with self”

b. abāg āz  
with zeal  
"with zeal"

(Abolghassemi 1996a: p.227)

In (34a), the argument of P° precedes it; in (34b), the argument of P° follows, indicating that Middle Persian has both prepositions and postpositions. This characteristic of PPs was present in Old Persian, but is absent from Modern Persian. Two analyses are possible for PPs in this period. First, we can assume that in (34a), the only argument of P° is in its Spec, but in (34b) it is in its complement. Second, we can suppose that the argument of P° appears in its complement position to the right, and in cases like (34a), the argument is in a derived position, motivated by some kind of Move. None of these options contradicts the head-initial configuration for PPs. In both orders (34a, b), the specifier position precedes the head and the complement follows it, as is consistent with the general S-H-C configuration.

### 6.3.4 VP in Middle Persian

As in Old Persian, word order in Middle Persian is varied with some scholars (Abolghassemi 1996a: p.362) suggesting it has free word order. Nevertheless, the more frequent word order is SOV as illustrated in (35):

(35) ardawān kanīzag xwāst (Abolghassemi 1996b: p.224 No.19)  
ardavan girl summoned  
"Ardavan summoned the girl."

The other two word orders observed in Middle Persian are SVO and VSO as shown in (36) and (37), respectively:

(36) ušān āwurd dabīr ī frahixtag (Abolghassemi 1996b: p.199 No.23)  
and-they brought writer Ez learned  
"They brought a learned writer."

- (37) *pursīd dānāg ō mēnōg xrad* (Abolghassemi 1996b: p.236)  
*asked Dana to Minu xerad*  
 “Dana asked Minuye xerad.”

In accordance with the theoretical foundations of this dissertation, I assume that the basic order for VPs in Middle Persian is SVO, with the other two orders representing derived ones. Following Roberts’s (1997) analysis of VPs in Old English, and based on my analysis of VPs in Old Persian, I assume that the VPs of Middle Persian are also underlyingly VO. Therefore, in (36), *āwurd* “brought” is the head of VP which subcategorizes for its complement *dabīrī frahixtag* “a learned writer” to the right. The operation Merge produces VO, and the same operation selects the subject *ušan* “they” to the left as the Spec VP, with the resulting SVO configuration in (36). In case of (35), *V\** selects Obj to its right as the complement and Subj to the left as its Spec. The operation Move then displaces the object into the preverbal position and produces an SOV order. In case of (37), the operation Merge produces an SVO order; then *V\** moves to a position before Subj for emphasis. The exact position to which Obj in (35) and *V\** in (37) move will be discussed in the next subsection.

### 6.3.5 Middle Persian Sentences

The discussion of VPs in Middle Persian in 6.3.4 lead us to the conclusion that supposing a head-initial status for VPs in this language optimally exhibits the structure of this category, and also renders a robust consistency in our analysis of Middle Persian in relation to the head parameter. The examination of Middle Persian IPs provides additional support to that claim. As we said in the analysis of IPs in Old Persian. throughout this thesis, the functional category IP is split into AgrsP, TP, and AgroP in a manner that AgrsP selects TP as its complement to the right, and TP, in turn, selects AgroP as its complement to the right, and at

last AgroP subcategorizes for its complement VP to the right. In the next step, the constituents of VP check their features with the appropriate heads or Specs in related functional categories, and hence the derivation converges. To express this process concretely, we return to No. (36) which was considered as the basic word order SVO. As we said before, in the process of VP structure, at first V' selects its complement Obj to the right, and its Spec Subj to the left. Under the EPP and in order to check its nominative feature, Subj raises to the highest specifier position in Spec AgrsP, observing MLC as justified in case of the same Move in Modern Persian. Head-to-head movement raises V' to Agro' and finally to T'. The first phase of this head movement, that is V'-to-Agro' Move, makes Obj *equidistant* from both Spec VP and Spec AgroP. Obj raises to its second choice and lands in Spec AgroP, checking its accusative feature. The outcome of these consecutive Moves will be an SVO word order, as illustrated in (38):

(38)

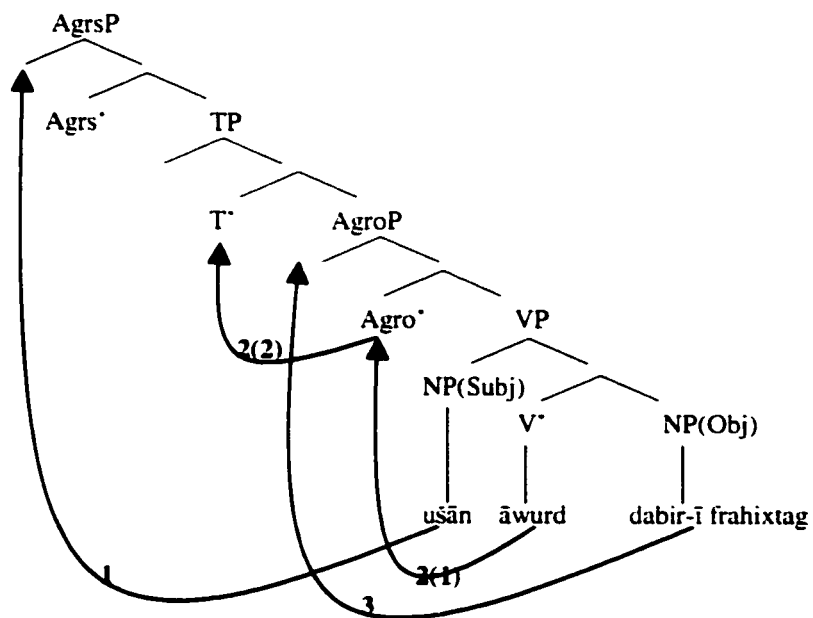

As in Modern Persian and Old Persian, the SOV order of (35), is assumed to be a result of “Stylistic Move” which raises Obj from Spec AgroP to Spec TP, yielding the SOV order of (35), as shown in (39):

(39)

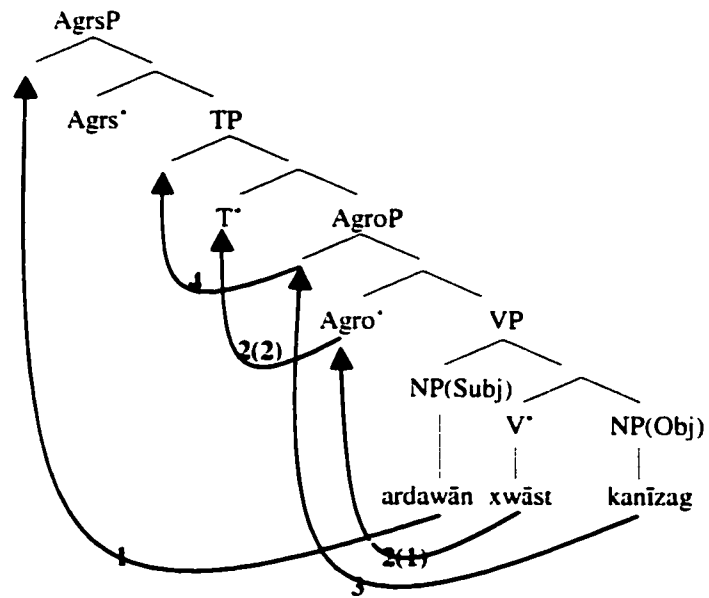

In the case of (37), the operations described for (38), produce an SVO sentence. Then, the topicalized feature of V\* raises it from T\* to Agrs\* and finally in Top\* by head movement, yielding the topicalized VSO order as shown in (40):

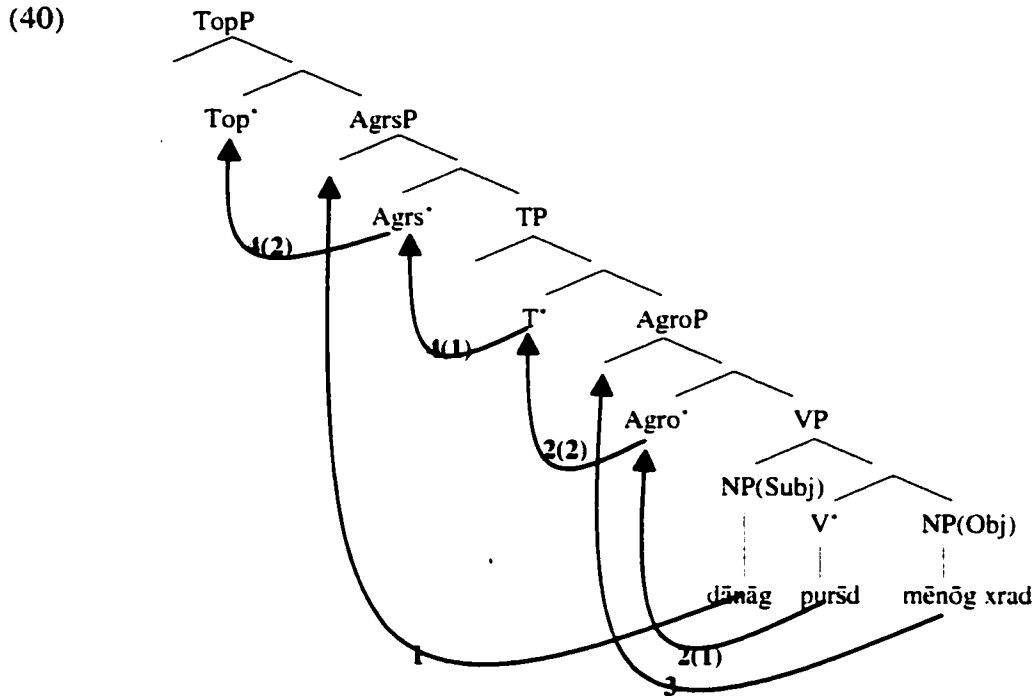

To conclude my analysis of Middle Persian sentences, we observed that although they exhibit variation in word order, just as for Old Persian, a head-initial analysis of IPs optimally explained this variation.

### 6.3.6 CP in Middle Persian

Middle Persian CPs are head-initial in that the complementizer head selects its complement to the right as illustrated in (41):

- (41) *kū sāsān az tohmag ī dārā zād-ested.* (Abolghassemi 1996b: p.224, No.8)  
*that Sasan from origin Ez Darius born-is*  
 "That Sasan is of Darius origin."

In (41), *kū* “that” the  $C'$  of CP subcategorizes for its complement to the right which implies a head-initial status for CPs in Middle Persian.

### **6.3.7 Summary and Conclusion of Middle Persian**

Our investigation of phrasal categories in Middle Persian indicated no difference with Old Persian with respect to the directionality parameter, except in APs. In Old Persian, AP complements could precede or follow the head, while in Middle Persian, the APs had a fixed Head-Complement order. Noun phrases were analyzed as NPs in a Spec-Head-Complement configuration, and PPs showed a head-initial order and the alternative head-final order. Despite the existence of different orders in VPs, it was argued that an SVO order can be justified. The process of feature checking of the constituents of the VP in the functional categories above VP showed a head-initial configuration for the functional categories AgrsP, TP and AgroP. Finally, it was argued that in CPs,  $C'$  selects its complement to the right.

## **6.4 Conclusion of Chapter 6**

This concludes my diachronic study of the phrasal categories investigated in Modern Persian. The results of my survey of Old and Middle Persian are noted below:

- 1) I analyzed nominal phrases in Old and Middle Persian as NPs rather than DPs as proposed for this category in Modern Persian. However, both DPs and NPs display a consistent Spec-Head-Complement configuration in the three periods. Also, the comparative survey revealed the importance of the EzP in all stages of the language.
- 2) A change is witnessed in the order of  $A'$  and its complement in the history of Persian. While in Old Persian, APs were both head-initial and head-final, the head-final order

was lost in Middle Persian. From this period on, Persian shows an exclusive head-initial configuration for APs.

- 3) PPs, like APs, have undergone a change regarding the head parameter. While both Old Persian and Middle Persian PPs show head-initial and head-final configurations, this option is lost in Modern Persian, which shows an exclusive head-initial PP.
- 4) From Old Persian to Modern Persian, the language tolerates some flexibility in the order of the constituents within the VP, a characteristic which has led some researchers to posit free order for Persian. Nevertheless, in all three periods I advocate a head-initial analysis for this category, with other orders being derived. This results in an underlying SVO word order for VPs in all periods of Persian.
- 5) Feature checking entails that constituents in the VP check their features in appropriate positions in the functional categories dominating the VP. In the case of the clause, the highest functional projection AgrsP selects TP to the right as its complement. Then, TP subcategorizes for AgroP to the right as its complement, and, at last, AgroP selects VP to its right as its complement. All three functional heads appear in a Spec-Head-Complement configuration. The three Specs of those three functional categories each check the feature of an argument of V': Spec AgrsP checks the nominative feature of Subj, Spec AgroP checks the accusative feature of Obj, and Spec TP is reserved for checking the stylistic features of Obj. Also, Head-to-Head movement moves V' to T'. These processes produce both the unmarked *basic* SVO order and the *more frequent* SOV order.
- 6) CP is also head-initial in all three periods of Persian.

- 7) **TopP** which dominates other XPs is also a head-initial category in all three periods. Spec **TopP** is the landing site for checking the topic feature of **Obj** which yields OSV order, and **Top'** is the landing site for **V'** when it has a topicalized interpretation in a sentence with a VSO order.

## **Chapter 7**

### **Summary and Conclusions**

This chapter winds up this dissertation and brings about the opportunity to evaluate the whole research. Following a summary of the thesis, I review the conclusions obtained.

#### **7.1 Summary**

In Chapter 1, I introduced the aim of this research which was to provide an analysis of Persian phrase structure, with special emphasis on the head parameter. It was discussed that some well-known facts about the head-initial status of all phrasal categories except VPs in addition to some observations regarding the latter which had been ignored previously are encouraging motivations towards establishing a consistent approach to the underlying position of head in all Persian maximal projections. After defining the problem and clarifying the fundamental goals of the research, I reviewed the theoretical foundations of the thesis. Basically, this research follows an antisymmetric, minimalist approach to the subject. That is, this thesis is established on two basic theories. First, the antisymmetric perspective of syntax as proposed by Kayne (1994) in his Linear Correspondence Axiom (LCA), and second, the Minimalist Program as proposed by Chomsky in his different papers in the 90's. The core of the LCA is its general Spec-Head-Complement configuration which is supposed to be applicable to all maximal projections. In addition to the LCA, the basic elements of the Minimalist Program such as Merge, Agree, Move, Minimal Link Condition (MLC) and so on were introduced. Then, the language under investigation which is called

the Standard Colloquial Persian is introduced, and at last, an overview of previous works on Persian syntax is presented. The purpose of this review is to provide a general background on different aspects of this language and especially on those aspects which have a role in this research.

In Chapter 2, I investigated the *Ezafe* Phrase (EzP), a construction specific to Persian. The term *Ezafe* which means "addition" refers to the morpheme /e/ which appears between the head of an NP or AP and the modifiers following the head. After reviewing the literature on this structure which is customarily referred to as the "Ezafe Construction", I proposed that this construction is the projection of the head *Ezafe*, phonetically realized as *e*, *ye* or  $\emptyset$ . This head selects its complement to the right from all non-verbal phrasal categories. EzP can be repeated in a DP or AP, making possible the occurrence of more complements for the same head. Spec EzP is normally non-filled and occurs to the left of Ez'. This position is filled in multi-complement DPs, in the way that NP originates in the Spec of the lowest EzP and raises up to the Spec of the highest EzP.

Nominal Phrases are investigated in chapter 3. In 3.1, the observations which gave rise to the analysis of Nominal Phrases as DPs are discussed and the DP Hypothesis is introduced. In 3.2, the applicability of the DP Hypothesis for Persian is investigated and accepted. It is shown that in this language, nominal phrases should be treated as DPs headed by /e/, /i/ or /ə/ which select an NP as their complement to the right. Then, N' overtly moves to D', yielding the actual N'+D' order. Having decided about the head of DP, 3.3 surveys the categories which fill the specifier position of DP and also NP. It is discussed that Spec DP is filled by a DemP or QP or NumP, elements which are in complementary distribution. Spec NP is the position of superlatives and ordinal numbers plus a very small

set of adjectives. In 3.4, it is shown that N<sup>o</sup> subcategorizes for its complement to the right from an NP or AP or PP or CLP. Considering the fact that N<sup>o</sup>, in Persian, can be modified by more than one complement to the right, it is the EzP that regulates the occurrence of more complements in a manner that there is only one complement for a head at a time. I also examine the order of the post-N<sup>o</sup> complements in this section. Finally, in 3.5, the conclusions of the chapter are presented.

In chapter 4, I analyze verb phrases, noting their special status due to the generation of the verb and both its external and internal arguments in this phrase. This implies that the underlying order of the constituents in the VP represents the underlying sentential word order. This peculiarity led me to review the previous scholarship on the sentence word order in 4.2, and then analyze these works in 4.3. This analysis concludes that although the more *frequent* order is SOV, nothing indicates that SVO is a marked order. In 4.4, it was argued that in circumstances that Persian allows two alternative orders in unmarked situations, the existence of some evidence in favor of an SVO order is indicative of an underlying head-initial status for VPs and hereby sentences. I presented methodological argumentation against a dual directionality for VPs as well as empirical evidence in favor of an underlying SVO word order. This evidence include a) the observation that both SOV and SVO orders are possible in unmarked situations, b) the post-verbal generation of CP complements, c) the structure of clitics and d) the position of adverbs relative to V<sup>o</sup> and its complement. On the basis of this evidence, and the lack of evidence (other than frequency) supporting the SOV order, I conclude that SVO should be considered as the *basic* word order from which the *more frequent* SOV is derived. Following this, in 4.5, I investigate Dative Constructions. Finally, in 4.6, a summary of the chapter and the conclusions are presented.

Chapter 5 introduces other phrasal categories. In 5.1, APs are surveyed. It is shown that A' selects its complement to the right. The complement is an EzP which, in turn, selects its complement an NP or PP. Spec AP is potentially filled with an AdvP. PPs which are discussed in 5.2 are headed by P' which selects a DP to its right as its complement. The specifier position of PPs, if realized, is filled by another PP. In 5.3, the structure of IPs is investigated. IP is split into AgrsP, TP and AgroP which are the functional domain for checking the relevant features of the constituents of VP. In chapter 4, it was shown that the operation Merge builds up the *basic* SVO order of VP. Here, it is discussed that the operation Move raises Subj, V' and Obj to relevant positions in the functional domain, producing the PF realization of the sentence. Subj raises to Spec AgrsP to check its nominative feature and under the influence of EPP, Obj raises to Spec AgroP in order to check its accusative feature, and V' ends up in T'. These Moves bring about a sentence with an SVO order which was called the *basic* order. The *more frequent* SOV order is the result of a "Stylistic Move" which raises Obj to Spec TP. Also, it was argued that IO checks its feature by raising to Spec AgrioP. In the appendix to this chapter, I also examine the functional categories CP and TopP. In Persian, CP is headed by the complementizer *ke* "that" which selects an IP as its complement to the right. Spec CP is the landing site for WH-movement. TopP is another functional category above IP whose head and Spec are the landing sites for V' or Obj in two OSV and VSO orders with focus interpretation.

In Chapter 6, I investigate the structure of the phrasal categories discussed earlier in the previous stages of Persian. In 6.1, a short history of this language is presented. In 6.2, NPs, APs, PPs, VPs, IPs, TopPs and CPs in Old Persian are surveyed. In 6.3, the same

categories in Middle Persian are investigated. Finally, in 6.4, the conclusion of comparative study of these three main stages of Persian is presented.

## **7.2 Conclusions**

The investigation into Persian phrase structure conducted in this dissertation followed the Minimalist Program. Based on this approach, a language consists of a lexicon and a computational system. The computational system draws from the lexicon to form derivations. Three operations Merge, Move and Agree are responsible for putting the elements chosen from the lexicon together and building up new structures. The Minimalist assumptions coupled with the Linear Correspondence Axiom (LCA) which considers the Spec-Head-Complement configuration as a component of Universal Grammar brought about satisfactory results in the analysis of different phrasal categories of Persian.

The lexical categories NP, AP and PP appeared to be exclusively head-initial, as discussed before by others. I have shown that VPs, too, should be analyzed as head-initial categories. This finding, which was argued for extensively, gives a consistent Spec-Head-Complement order to all lexical phrasal categories in Persian. I also provided evidence supporting a head-initial analysis of the functional categories of DP, IP (AgrsP, TP and AgroP), CP and TopP. Additionally, the EzP, a construction specific to Persian, was also shown to be head-initial. These robust findings support a uniform head-initial analysis of all phrasal categories in Standard Colloquial Persian, a characteristic which identifies it, underlyingly, as an SVO language.

## REFERENCES

- Abney, S.** (1986). "Functional Elements and Licensing". Paper presented at *GLOW* Conference, Barcelona.
- Abney, S.** (1987). "The English noun phrase in its sentential aspect". Ph.D. dissertation, MIT.
- Abolghassemi, M.** (1994). *A History of the Persian Language*. Tehran: SAMT.
- Abolghassemi, M.** (1996a). *A Historical Grammar of the Persian Language*. Tehran: SAMT.
- Abolghassemi, M.** (1996b). *A Manual of Old Iranian Languages*. vol.1. Text. Tehran: SAMT.
- Abolghassemi, M.** (1997). *A Manual of Old Iranian Languages*. vol.2. Grammar & Lexicon. Tehran: SAMT.
- Abraham, W., S. Epstein, H. Thráinsson & J. Zwart.** (eds.). (1996). *Minimal Ideas*. Amsterdam: John Benjamins Publishing Company.
- Adger, D., S. Pintzuk, B. Plunkett & G. Tsoulas** (eds.). (1999). *Specifiers: Minimalist Approaches*. Oxford: Oxford University Press.
- Aghbar, A. A.** (1981). "Case Grammar and Persian Verbs". Ph.D. dissertation. Georgetown University.
- Akmajian, A. & F. Heny** (1975). *An Introduction to the Principles of Transformational Syntax*. Cambridge, Mass: MIT Press.
- Alexiadou, A. & E. Anagnostopoulou.** (1998). "Parameterizing Agr: Word Order, V-Movement and EPP-Checking". *Natural Language & Linguistic Theory* 16, 491-539.
- Aoun, J. & E. Benmamoun** (1998). "Minimality, Reconstruction, and PF Movement". In *Linguistic Inquiry*, 29, No. 4, p. 569-597.
- Aoun, J., N. Hornstein, D. Lightfoot & A. Weinberg** (1987). "Two types of locality". *Linguistic Inquiry* 18, 537-77.
- Arnaudova, O.** (1995). "The Bulgarian Noun Phrase". MA Thesis. University of Ottawa.
- Bach, E.** (1971). "Questions". *Linguistic Inquiry* 2, 153-166.

- Bahar, M. T., Q. Rashid-Yasami, A. Qarib, J. Homai, and B. Forouzanfar** (1938). *Dastur-e zabān-e Fārsi* (Persian Grammar). Tehran: Piruz.
- Baker, M.** (1988). *Incorporation: A Theory of Grammatical Function Changing*. Chicago: University of Chicago Press.
- Barjasteh, D.** (1983). "Morphology, Syntax & Semantics of Persian Compound Verbs: A Lexicalist Approach". Doctoral dissertation, University of Illinois at Urbana-Champaign.
- Batani, M-R.** (1969). *A Description of the Grammatical Structure of Persian Language*. Tehran: Amir Kabir.
- Bianchi, V.** (1999). *Consequences of Antisymmetry: Headed Relative Clauses*. Berlin: Mouton de Gruyer.
- Bobaljik, J. & D. Jonas.** (1996). "Subject Positions and the Roles of TP". In *Linguistic Inquiry* 27, No. 2, 196-236.
- Boyle, J. A.** (1966). *A Grammar of Modern Persian*. Wiesbaden: Otto Hamassowitz.
- Brame, M.** (1981). "The General Theory of Binding and Fusion". In *Linguistic Analysis*, vol. 7, No. 3.
- Brugè, L.** (1995). *Il movimento del dimostrativo in Spagnolo*. Ms., Università di Venezia e Padova
- Brunner, C. J.** (1977). *A System of Western Middle Iranian*. Delmar, NY: Caravan Books.
- Cheng, L. & R. Sybesma** (1999). "Bare and Not-So-Bare Nouns and the Structure of NP". In *Linguistic Inquiry*, vol. 30, No. 4, pp. 509-542.
- Chierchia, G.** (1998) "Reference to Kinds across Languages". In *Natural Language Semantics* 6: p. 339-405.
- Chomsky, N.** (1957). *Syntactic Structures*. The Hague: Mouton.
- Chomsky, N.** (1965). *Aspects of the Theory of Syntax*. Cambridge, Mass: MIT Press.
- Chomsky, N.** (1970). "Remarks on Nominalization". In Roderick A. Jacobs and Peter S. Rosenbaum (eds.) *Readings in English Transformational Grammar*. Waltham, Mass: Ginn & Co., 184- 221.
- Chomsky, N.** (1973). "Conditions on Transformations". In Stephen R. Anderson and Paul Kiparsky (eds.) *A Festschrift for Morris Halle*. New York: Holt, Rinehart and Winston, 232-86.

- Chomsky, N.** (1977). *Essays on Form and Interpretation*. Amsterdam: Elsevier North Holland.
- Chomsky, N.** (1980). "On Binding". *Linguistic Inquiry* 11, 1-46.
- Chomsky, N.** (1981). *Lectures on Government and Binding*. Dordrecht: Foris.
- Chomsky, N.** (1986a). *Barriers*. Cambridge, Mass: MIT Press.
- Chomsky, N.** (1986b). *Knowledge of Language: Its Nature, Origin and Use*. New York: Praeger.
- Chomsky, N.** (1991). "Some notes on economy of derivation and representation". In Chomsky (1995).
- Chomsky, N.** (1993). "A minimalist program for linguistic theory". In Chomsky (1995).
- Chomsky, N.** (1994). "Bare Phrase Structure". In G. Webelhuth (ed.) *Government and Binding Theory and the Minimalist Program*. Cambridge, Mass: Blackwell Publishers.
- Chomsky, N.** (1995). *The Minimalist Program*. Cambridge, Mass: MIT Press.
- Chomsky, N.** (1998). "Minimalist Inquiries: The Framework". (MIT Occasional Papers in Linguistics 15) MITWPL, Department of Linguistics and Philosophy. Cambridge, Mass: MIT. [To appear in *Step by Step: Essays on Minimalist Syntax in Honor of Howard Lasnik*. eds. Roger Martin, David Michaels and Juan Uriagereka (2000). Cambridge, Mass: MIT Press].
- Chomsky, N.** (1999). "Derivation by Phase". Ms.
- Chomsky, N. & H. Lasnik.** (1977). "Filters and Control". *Linguistic Inquiry* 8, 425-504.
- Chomsky, N. & H. Lasnik.** (1993). "The theory of principles and parameters". In Chomsky (1995).
- Cinque, G.** (1995). *Italian Syntax and Universal Grammar*. Cambridge: Cambridge University Press.
- Cinque, G.** (1996). "The Antisymmetric Programme: Theoretical and Typological Implications". In *Journal of Linguistics* 32, pp. 447-464.
- Cinque, G., J. Koster, J-Y. Pollock, L. Rizzi & R. Zanuttini.** (eds.). (1994). *Paths Towards Universal Grammar: Studies in Honor of Richard Kayne*. Washington: Georgetown University Press.

- Comrie, B.** (1981). *Language Universals and Linguistic Typology*. Chicago: The University of Chicago.
- Cook, W.** (1979). *Case Grammar: Development of the Matrix Model (1970-1978)*. Washington, D.C.: Georgetown University Press.
- Cook, V. J. & M. Newson** (1996). *Chomsky's Universal Grammar: An Introduction*. Cambridge, Mass: Blackwell Publishers.
- Cowper, E.** (1992). *A Concise Introduction to Syntactic Theory: The Government-Binding Approach*. Chicago: The University of Chicago Press.
- Dabir-Moghaddam, M.** (1982). "Syntax and Semantics of Causative Constructions in Persian". Ph.D. dissertation. University of Illinois at Urbana-Champaign. .
- Darzi, A.** (1995). "Word Order, NP-Movement & Opacity Conditions in Persian". Doctoral dissertation, University of Illinois at Urbana-Champaign.
- Delsing, L.** (1988). "The Scandinavian Noun Phrases". In *Working Papers in Scandinavian Syntax* 42, 57-80.
- Diesing, M.** (1992). "Bare Plural Subjects and the Derivation of Logical Representation". In *Linguistic Inquiry*, 23, No.3, p. 353-380.
- Dobrovie-Sorin, C.** (1987). "A propos de la structure du groupe nominal en roumain". *Rivista di grammatica generativa* 12: 123-152.
- Farrokhpey, M.** (1979). "A Syntactic and Semantic Study of Auxiliaries and Modals in Modern Persian". Ph.D. dissertation. University of Colorado at Boulder.
- Fassi Fehri, A.** (1989). "Generalized IP structure, Case and VS order". In *Working papers in linguistics 10: Functional heads and clause structure*, 75-113. Cambridge, Mass: MIT, Department of Linguistics and Philosophy.
- Foroughy, A.** (1944). *A Concise Persian Grammar*. New York: Orientalia, Inc.
- Fujita, K.** (1996). "Double objects, causatives and derivational economy". *Linguistic Inquiry*, 27, 146-173.
- Fukui, N. & M. Speas** (1986). "Specifiers and Projections". *MIT Working Papers*.
- Ghomeshi, J.** (1996). "Projection and Inflection: A Study of Persian Phrase Structure". Ph.D. dissertation. University of Toronto.

- Ghomeshi, J.** (1997a). "Topics in Persian VPs". In *Lingua* 102, p. 133-167.
- Ghomeshi, J.** (1997b). "Non-Projecting Nouns and the Ezafe Construction in Persian". In *Natural Language and Linguistic Theory* 15, p. 729-788.
- Giusti, G.** (1992). "Heads and modifiers among determiners: evidence from Romanian and German". *University of Venice Working Papers in Linguistics* 3. CLI. (Published in Cinque, G. & G. Giusti (eds.) (1995) *Advances in Romanian Linguistics*. Amsterdam: Benjamins. 103-125).
- Greenberg, J. H.** (ed.). (1963). *Universals of Language*. Second Edition. Cambridge, Mass: MIT Press.
- Greenberg, J. H.** (ed.). (1978). *Universals of Human Language*. 4 volumes. Stanford, CA: Stanford University Press.
- Grimshaw, J.** (1991). Extended Projections. Ms., Brandeis University.
- Grosu, A.** (1988). "On the distribution of genitive phrases in Rumanian". *Linguistics* 26: 931-949.
- Guéron, J.** (1980). "On the Syntax and Semantics of PP Extraposition". In *Linguistic Inquiry* 11, No.4, p. 637-678.
- Haegeman, L.** (1991). "On the relevance of clitic placement for the analysis of subject-initial Verb Second in West Flemish". In *Groninger Arbeiten zur germanistischen Linguistik*, 34. Herausgeber: Werner Abraham.
- Haegeman, L.** (1994). *Introduction to Government and Binding Theory*. Cambridge, Mass: Blackwell.
- Haegeman, L.** (1997). *Elements of Grammar: Handbook in Generative Syntax* (ed.). Dordrecht: Kluwer Academic Publishers.
- Haegeman, L. & J. Guéron.** (1999). *English Grammar: A Generative Perspective*. Oxford: Blackwell Publishers.
- Hajati, A-K.** (1977). "Ke-Constructions in Persian: Descriptive & Theoretical Aspects". Doctoral dissertation, University of Illinois at Urbana-Champaign.
- Hale, K. & S. J. Keyser** (1991). "On the Syntax of Argument Structure". *Lexicon Project Working Papers* 34, MIT.
- Hale, K. & S. J. Keyser** (1993). "On Argument Structure and the Lexical Expression of Syntactic Relations". In Hale, K. & S. J. Keyser (eds.) *The View from Building 20*. Cambridge, Mass: MIT Press.

- Halliday, M. A. K.** (1961). "Categories of the Theory of Grammar". In *Word*. Vol. 17, No.3, p.24-92.
- Halpern, A.** (1995). *On the Placement and Morphology of Clitics*. Ph.D. dissertation. Stanford: CSLI.
- Hashemipour, M.** (1989). "Pronominalization and Control in Modern Persian". Ph.D. dissertation. University of California, San Diego.
- Hawkins, J.** (1983). *Word Order Universals*. New York: Academic Press.
- Hendrick, R.** (1976). "Prepositions and the X'-Theory". In J. Emonds, (ed.), *UCLA Papers in Syntax*, vol. 7, Fall 1976.
- Hendrick, R.** (1995). "Morphology". In G. Webelhuth *Government and Binding Theory and the Minimalist Program*. Cambridge, Mass: Blackwell Publishers.
- Holmberg, A.** ed. (1992). *Papers from the Workshop on the Scandinavian Noun Phrase*. Report 32, Department of General Linguistics, University of Umeå.
- Holmberg, A.** (2000). "Scandinavian Stylistic Fronting: How Any Category Can Become an Expletive?" In *Linguistic Inquiry* 31, No. 3, Summer 2000, 445-483.
- Homayun-Farrokh, A. R.** (1959). *A Comprehensive Grammar of the Persian Language*. Tehran: Elmi Publishing Company.
- Hornstein, N.** (1995). *Logical Form: From GB to Minimalism*. Cambridge, MA: Blackwell Publishers.
- Hudson-Williams, T.** (1936). *A Short Grammar of Old Persian*. The University of Wales Press Board.
- Jackendoff, R.** (1972). *Semantic Interpretation in Generative Grammar*. Cambridge, Mass: MIT Press.
- Jaeggli, O.** (1982). *Topics in Romance Syntax*. Dordrecht: Foris.
- Jaeggli, O.** (1986). "Three Issues in the Theory of Clitics: Case, Doubled NPs and Extraction". In H. Borer (ed.) *Syntax and Semantics 19: The Syntax of Pronominal Clitics*, 15-45. Orlando, FL: Academic Press.
- Jakobson, R.** (1963). "Implications of Language Universals for Linguistics". In J. Greenberg (ed.). *Universals of Language*. Cambridge, Mass: MIT Press.
- Jazayery, M. A. & H. H. Paper** (1961). *A Reference Grammar of Modern Persian*. Ann Arbor: The University of Michigan Press.

- Johnson, D. & S. Lappin.** (1999). *Local Constraint vs. Economy*. Stanford, CA: CSLI.
- Jones, W.** (1809). *A Grammar of the Persian Language*. Delhi: Low Price Publications.
- Jónsson, J. G.** (1991). "Stylistic Fronting in Icelandic". In *Working Papers in Scandinavian Syntax* 48, 1-43. Department of Scandinavian Languages, University of Lund.
- Karimi, S.** (1989). "Aspects of Persian Syntax, Specificity, and the Theory of Grammar". Ph.D. dissertation. University of Washington.
- Karimi, S.** (1990). "Obliqueness, Specificity and Discourse Functions: A Story of Rā in Persian". In *Linguistic Analysis*, Vol. 20, No. 3 & 4.
- Karimi, S.** (1991). "Review of the Paper About Rā in Persian". In *Iranian Journal of Linguistics*, Vol. 8, No. 1 & 2, 1991. Tehran: Iran University Press.
- Karimi, S.** (1994). "Word Order Variations in Contemporary Persian". In M. Marashi (ed.) *Persian Studies in North America: Studies in Honor of Mohammad Ali Jazayeri*. Bethesda, Maryland: Iranbooks.
- Karimi, S.** (1999). "Specificity Effect: evidence from Persian". In *The Linguistic Review*, vol.16, No.2, p. 125-141
- Kayne, R.** (1975). *French Syntax*. Cambridge, Mass: MIT Press.
- Kayne, R.** (1984). *Connectedness and Binary Branching*. Dordrecht, Holland: Foris Publications.
- Kayne, R.** (1991). "Romance Clitics, Verb Movement, and PRO". In *Linguistic Inquiry*, 22-4, p. 647-686.
- Kayne, R.** (1994). *The Antisymmetry of Syntax*. Cambridge, Mass: MIT Press.
- Kayne, R.** (1998). "Overt vs. Covert Movement". In *Syntax* 1:2, August 1998, 128-191.
- Kemenade, A.** (1987). *Syntactic Case and Morphological Case in the History of English*. Dordrecht: Foris Publications.
- Kent, R.** (1953). *Old Persian*. New Haven, Connecticut: American Oriental Society.
- Khanlari, P.** (1971). *Tārix-e Zabān-e Farsi (The History of Persian Language)*. Vol. 1. Tehran: Bonyād-e Farhang-e Iran.

- Khanlari, P.** (1976). *Dastur-e Zabān-e Fārsi*. (The Grammar of Persian Language). Tehran: Bonyād-e Farhang-e Iran.
- Koizumi, M.** (1995). "Phrase Structure in Minimalist Syntax". Ph.D. dissertation. MIT.
- Koster, J.** (1975). "Dutch as an SOV Language". *Linguistic Analysis*, 1, p. 111-136.
- Koster, J.** (1994). "Predicate Incorporation and the Word Order of Dutch". In G. Cinque et al. (eds.) *Paths Towards Universal Grammar*. Washington, D. C.: Georgetown University Press.
- Kruse, A. F.** (1978). "The Structural Configuration of Persian". University of Washington's *Working Papers in Linguistics*, No.4.
- Kural, M.** (1997). "Postverbal Constituents in Turkish and the Linear Correspondence Axiom". In *Linguistic Inquiry*, vol. 28, No. 3, 1997, pp. 498-519.
- Larson, R.** (1988). "On the double object construction". *Linguistic Inquiry* 19, 335-391.
- Larson, R.** (1990). "Double objects revisited: Reply to Jackendoff". *Linguistic Inquiry* 21, 589-632.
- Lasnik, H.** (2000). *Syntactic Structures Revisited*. Cambridge, MA: The MIT Press.
- Lasnik, H. & J. Uriagereka.** (1988). *A Course in GB Syntax*. Cambridge, Mass: MIT Press.
- Lazard, G.** (1957). *Grammaire du persan contemporain*. Paris: Librairie C. Klincksieck.
- Lazard, G.** (1992). *A Grammar of Contemporary Persian*. Costa Mesa, California: Mazda Publishers. (Translated from French by Shirley Lyons: first published in 1957 as *Grammaire de Persan Contemporain*. Paris: Klincksieck.).
- Lehmann, W. P.** (1971). "On the Rise of SOV Patterns in New High German". In K. G. Schweisthal (ed.), *Grammatik, Kybernetik, Kommunikation (Festschrift Für Alfred Hoppe)*. Bonn: Dümmler.
- Longobardi, G.** (1994). "Reference and Proper Names: A Theory of N-Movement in Syntax and Logical Form". In *Linguistic Inquiry*, vol.25, No. 4, p. 609-665.
- Mahootian, S.** (1993). "A Null Theory of Code-switching". Ph.D. dissertation. Northwestern University, Illinois.
- Marashi, M.** (1970). "The Persian Verb: A Partial Description for Pedagogical Purposes". Ph.D. dissertation. The University of Texas at Austin.

- McCawley, J. D.** (1970). "English as a VSO Language". *Language*, 46: 286-99.
- Meshkat al-Dini, M.** (1987). *Persian Transformational Syntax*. Mashhad, Iran: Ferdowsi University Press.
- Meshkat al-Dini, M.** (1998). "Head Position in Subordinate Clauses and Phrases in Persian". Paper presented at the 4<sup>th</sup> Conference on Linguistics. Tehran: Allameh Tabatabai University.
- Miremadi, A.** (1997). *Persian Syntax: A G.B-Based Analysis*. Tehran: SAMT.
- Moinzadeh, A.** (1995). "On the Word Order in Persian: SVO or SOV". Ms., Department of Linguistics, University of Ottawa.
- Moinzadeh, A.** (1998). "Persian Word Order". In *CLA Annual Conference Proceedings*, 1998, University of Ottawa, 299-311.
- Moinzadeh, A.** (1999). "Bilingual Phenomena: Towards the Fateful Triangle of Language Mixture". In *Cahier Linguistiques d'Ottawa*, vol. 27, June 1999, University of Ottawa.
- Moyne, J. A.** (1970). "The Structure of Verbal Constructions in Persian". Ph.D. dissertation. Harvard University.
- Moyne, J. A. & G. Carden** (1974). "Subject Reduplication in Persian". *Linguistic Inquiry*, Vol 5.
- Ordóñez, F.** (1997). "Word Order and Clause Structure in Spanish and Other Romance Languages". Doctoral dissertation, The City University of New York.
- Ouhalla, J.** (1988). "Movement in Noun Phrases". Paper presented at the *LAGB Meeting*, Durham, March 1988.
- Ouhalla, J.** (1990). "Sentential negation, relativized minimality, and the aspectual status of auxiliaries". *The Linguistic Review*, 7, 183-213.
- Ouhalla, J.** (1992). "Focus in Standard Arabic: the identification requirement and the Principle of Economy". Ms. Queen Mary and Westfield College.
- Ouhalla, J.** (1999). *Introducing Transformational Grammar: From Principles and Parameters to Minimalism*. Second Edition. London: Arnold.
- Pesetsky, D.** (1982). *Paths and Categories*. Ph.D. dissertation. MIT.
- Phillot, D. C.** (1919). *Higher Persian Grammar*. Calcutta: The Baptist Mission Press.

- Pollock, J-Y.** (1989). "Verb Movement, Universal grammar, and the Structure of IP". *Linguistic Inquiry* 20, 356-424.
- Radford, A.** (1997). *Syntax: A Minimalist Introduction*. Cambridge: Cambridge University Press.
- Radford, A.** (1997). *Syntactic Theory and the Structure of English*. Cambridge: Cambridge University Press.
- Raghibdoust, S.** (1993). "Interrogative Constructions in Persian". M.A. Thesis. Department of Linguistics, University of Ottawa.
- Ritter, E.** (1988). "A head-movement approach to construct-state phrases". *Linguistics* 26: 909-929.
- Ritter, E.** (1991). "Two functional categories in noun phrases: evidence from Modern Hebrew". In Rothstein, S. (ed.). *Syntax and Semantics, 25: Perspectives on Phrase Structure*, 37-62.
- Rivero, M-L.** (1997). "Last Resort and V-movement in Balkan languages". Paper presented at the workshop on the syntax of Balkan languages. Athens Glow Colloquium. To appear in *Comparative Syntax of Balkan Languages*, (ed.), M-L Rivero & A. Ralli. New York: Oxford University Press.
- Rivero, M-L.** (1999). "Stylistic Verb Movement in Yes-No Questions in Bulgarian and Breton". In I. Kenesei (ed.), *Crossing Boundaries: Advances in the theory of Central and Eastern European languages*. Amsterdam/Philadelphia: John Benjamins Publishing Company.
- Rivero, M-L.** (In Press). *Verb Syntax and Interface Conditions*. New York: Oxford University Press.
- Rizzi, L.** (1997). "The Fine Structure of the Left Periphery". In L. Haegeman (ed.), (1997). *Elements of Grammar: Handbook of Generative Syntax*. Dordrecht: Kluwer.
- Roberts, I.** (1997). "Directionality and Word Order Change in the History of English". In Kemenade, A. van & N. Vincent (eds.) *Parameters of Morphosyntactic Change*. Cambridge: Cambridge University Press.
- Ross, J. R.** (1967). "Gapping and the Order of Constituents". In M. Bierwisch and K. E. Heidolph (eds.) *Progress in Linguistics*. The Hague: Mouton.
- Saito, M. & N. Fukui** (1998). "Order in Phrase Structure and Movement". In *Linguistic Inquiry*, vol. 29, No. 3, 1998, pp. 439-474.

- Samiian, V.** (1983). "Structure of Phrasal Categories in Persian: An X-Bar Analysis". Ph.D. dissertation. UCLA.
- Shlonsky, U.** (2000). "The Form of Semitic Noun Phrases". Ms.
- Siloni, T.** (1989). "Hebrew noun phrases: Generalized noun raising". Ms. Université de Genève.
- Siloni, T.** (1990). "On the parallelism between CP and DP: Hebrew semi relatives". *Proceedings LCJL*, 1.
- Soheili-Isfahani, A.** (1976). "Noun Phrase Complementation in Persian". Ph.D. dissertation. University of Illinois at Urbana.
- Sportiche, D.** (1988). "A Theory of Floating Quantifiers and its Corollaries for Constituent Structure". *Linguistic Inquiry* 19, 425-449. Reappeared in Sportiche (1998).
- Sportiche, D.** (1998). *Partitions and Atoms of Clause Structure: Subjects, agreement, case and clitics*. London/New York: Routledge.
- Stefanescu, I.** (1997). "The Syntax of Agreement in Romanian". Ph.D. dissertation, The City University of New York.
- Stowell, T.** (1981). "Origins of Phrase Structure". Ph.D. dissertation. MIT.
- Stowell, T.** (1989). "Subjects, specifiers, and X-bar theory". In *Alternative conceptions of phrase structure*, ed. M. Baltin & A. Kroch, 232-262. Chicago: University of Chicago Press.
- Stroik, T.** (1996). *Minimalism, Scope and VP Structure*. London: Sage Publications.
- Szabolsci, A.** (1983). "The possessor that ran away from home". *The Linguistic Review* 3: 89-102.
- Szabolsci, A.** (1994). "The noun phrase". In *Syntax and Semantics 27: The Syntactic Structure of Hungarian*, ed. F. Kiefer & K. Kiss, 179-274. San Diego, California: Academic Press.
- Tabaian, H.** (1974). "Conjunction, Relativization and Complementation in Persian". Doctoral dissertation, University of Colorado.
- Tang, C-C. J.** (1990). "Chinese phrase structure and the extended X'-theory". Doctoral dissertation. Cornell University, Ithaca. N.Y.

- Taraldsen, T.** (1990). "D-projections and N-projections in Norwegian". In *Grammar in Progress*, ed. Marina Nespør and Joan Mascaró, 419-431. Dordrecht: Foris.
- Tehranisa, S. H.** (1987). "A Syntactic and Semantic Analysis of Compound Nouns in Persian". Doctoral dissertation. The University of Michigan.
- Travis, L.** (1984). "Parameters and Effects of Word Order Variation". Doctoral dissertation, MIT.
- Ura, H.** (2000). *Checking Theory and Grammatical Functions in Universal Grammar*. New York/Oxford: Oxford University Press.
- Uriagereka, J.** (1995). "Aspects of the Syntax of Clitic Placement in Western Romance". In *Linguistic Inquiry* 29, No.1, p. 79-123.
- Vahedi-Langrudi, M. M.** (1994). "Scrambling and Word Order in Modern Farsi". In *Cahiers Linguistiques D'Ottawa*, Vol. 22.
- Vahedi-Langrudi, M. M.** (1996). "The Syntax, Semantics and Argument Structure of Complex Predicates in Modern Farsi". Doctoral dissertation, University of Ottawa.
- Vazirpoor, N.** (1977). *Dastur-e Zabān-e Fārsi* (The Grammar of Persian Language). Tehran: Sepāhiān-e Enghelāb University.
- Vennemann, T.** (1972). "Analogy in Generative Grammar, the Origin of Word Order". In L. Heilmann (ed.) *Proceedings of the Eleventh International Congress of Linguistics*, 2. Volumes (Bologna: Il Mulino) 2, 79-83.
- Webelhuth, G.** (ed.). (1995). *Government and Binding Theory & the Minimalist Program*. Oxford: Blackwell.
- Windfuhr, G.L.** (1979). *Persian Grammar: History and State of its Study*. The Hague: Mouton Publishers.
- Yarshater, E.** (1983). *The Cambridge History of Iran*. Vol. 3(2). Cambridge: Cambridge University Press.
- Zwart, J. W.** (1993). "Dutch Syntax: A Minimalist Approach". Ph.D. dissertation. University of Groningen.