

The Function of Number in Persian

Ladan Hamedani

Thesis submitted to the
Faculty of Graduate and Postdoctoral Studies
In partial fulfillment of the requirements
For the PhD degree in Linguistics

Department of Linguistics
Faculty of Arts
University of Ottawa

© Ladan Hamedani, Ottawa, Canada, 2011

Abstract

This thesis investigates the function of number marking in Persian, within the framework of principles and parameters (P&P), and its relationship to inflectional and derivational number marking. Following the assumption in Distributed Morphology that inflectional and derivational morphology are not distinct, the distribution and properties of number marking in Persian provide evidence for both inflectional and derivational number marking.

Assuming the two parameters of number marking (Wiltschko, 2007, 2008), number marking as a functional head and number marking as a modifier, I propose that number marking in Persian is mainly inflectional while number functions as a functional head; moreover, I propose that number marking in Persian can be derivational while number functions as a modifier. This explains that number morphology in Persian is not split to either inflectional or derivational. Rather, following Booij's (1993, 1995) claim that inflectional morphology can be used contextually as well as inherently, I propose that number morphology in Persian is inflectional while number is a functional head; however, it has inherent residues as a modifier.

Considering the functions of inflectional plural morphology in Persian, I argue that the functional category Number Phrase (NumP) is projected in Persian, and number is generated in the head of this functional category. Besides, Persian is a classifier language in which classifiers are in complementary distribution with plural marking. Following Borer's (2005) discussion of the complementary

distribution of plural marking and classifiers in Armenian, I argue that the head of NumP in Persian is either occupied by the plural maker or by full/empty classifiers.

Moreover, I show that the presence of bare singulars/plurals in certain syntactic positions in Persian is related to the projection/non-projection of NumP.

Acknowledgements

First, I would like to thank and express my utmost gratitude to Eric Mathieu, my PhD and second comprehensive exam supervisor. I thank him for his generous comments and guidance, which made me pursue my research and come up with new ideas. His crucial support and encouragement very much helped me develop my interest in syntax. I would not have been able to graduate without his patience, help, and understanding during the years.

My special thanks go to Arsalan Kahnemuyipour, the external member of my thesis committee. His generous and constructive comments and thoughts influenced my thesis a lot and helped me develop my ideas and perspective. His careful consideration and contribution go beyond this acknowledgement.

Also, I would like to thank the internal members of my thesis committee—Ana Arregui, Tahereh Sima Paribakht, and Andrès Salanova—and the committee's chairperson Danielle Fortin. Ana and Sima's support and encouragement during the years of my graduate studies were always valuable sources of inspiration. Ana improved my perspective of syntax with her thoughtful comments. Sima's insightful comments and careful advices contributed very much to the development of my work.

I would like to thank the Department of Linguistics at University of Ottawa for supporting me during my graduate program. My special thanks also go to Eta Schneiderman, who helped me especially in the beginning of my studies and supported me greatly throughout the years. Moreover, I would like to thank Juana

Munõz-Liceras, my first comprehensive exam supervisor, who enriched my insight of second language acquisition.

Besides, I wish to thank the Graduate Student Association (ADLINGA) members for their support, particularly Joseph Roy, Reza Falahati, Will Dalton, Melissa Chiasson, and Sonia Pritchard. Moreover, I thank Keren Tonciulescu, Neil Wick, and H el ene Tourigny for their help.

Finally, I would like to thank my family members. I thank my brother Peyman and his wife Valerie, who helped me greatly during all the years of my life in Ottawa, my parents and my brother Shahin in Iran, whose support and love invaluablely influenced my life, my daughter Mana for her love and encouragement, and in the end my husband Reza for his love, patience, support, and positive attitude.

Table of Contents

List of Abbreviations.....	viii
Chapter 1: Introduction	1
1.1 Introduction	1
1.2 The puzzles	4
1.3 Main proposals	11
1.4 Background: Modern Persian	15
1.4.1 Persian plural markers	16
1.4.2 Persian classifiers	22
1.4.3 Distribution of bare singulars/plurals	25
1.5 Theoretical framework	31
1.5.1 Plural marking parameters	33
1.5.2 Inflectional morphology	37
1.6 Outline of the thesis	38
Chapter 2: Distribution of plural morphology	42
2.1 Introduction	42
2.2 Inflectional vs. derivational plural morphology	43
2.2.1 Obligatoriness	43
2.2.2 Agreement	50
2.2.3 Plural marking inside compounds	61
2.2.4 Plural marking inside derivational morphology	65
2.2.5 Form-meaning mismatches (<i>pluralia tantum</i>)	70
2.2.6 Bare plurals	73
2.3 Summary	78

Chapter 3: Mass/count distinction in Persian	81
3.1 Introduction	81
3.2 The puzzles	82
3.3 The category Num and structural differences	89
3.4 The analysis	103
3.4.1 Grammaticized mass/count distinction in Persian	103
3.4.2 Modificational plural marking in Persian	115
3.4.3 Persian nominal roots	119
3.5 Summary	123
Chapter 4: The role of classifiers in Persian.....	124
4. 1 Introduction	124
4.2 Cross-linguistic role of classifiers	126
4.3 Distribution of classifiers in Persian	136
4.4 Classifiers and plural marking	147
4.5 Summary	167
Chapter 5: Bare singulars/plurals in Persian	169
5.1. Introduction	169
5.2 Distribution of bare singulars/plurals in Persian	170
5.2.1 Persian bare singulars/plurals in subject positions	173
5.2.2 Persian bare singulars/plurals in object positions	177
5.2.3 Persian bare singulars/plurals in predicative positions	194
5.3 The two morpho-syntactic parameters and bare nouns	195
5.3.1 The Free Agr parameter in English and Romance	195
5.3.1.1 Lack of number in predicative positions in Romance	197
5.3.1.2 Lack of number in predicative positions in Persian	200
5.3.1.3 Lack of number in bare singular arguments in Brazilian Portuguese .	202
5.3.1.4 Lack of number in bare singular arguments in Persian	206
5.3.2 Empty determiners in argument positions	209

5.3.2.1 The empty determiner in Persian	212
5.3.2.2 The expletive determiner in Persian	217
5.4. Summary	228
Chapter 6: Concluding remarks	230
References	234

List of Abbreviations

The abbreviations used to gloss the examples in Persian are according to those presented by Ghomeshi (2001), as shown in the following table:

DUR	the durative prefix (<i>mi-</i>)	POSS	possessive
EZ	the Ezafe marker (<i>-e</i>)	=	a symbol used
IMP	the imperative marker (<i>be-</i>)		between the non-
IND	the “indefinite” marker (<i>-i</i>)		verbal and verbal
NEG	the negative prefix (<i>næ-</i>)		part of a compound
OM	the “object marker” (<i>ra</i>)		verb
PART	participle (<i>-e</i>)	CL ¹	classifier
PAST	past tense	DEF	definite
PL	the plural marker (<i>-ha</i>)		
PRES	present tense		
SG	singular		
SBJ	the subjunctive prefix (<i>-be</i>)		
1SG, 2SG,	} the subject agreement affixes		
3SG, 1PL,			
2PL, 3PL			

¹ I use the abbreviation CL for classifiers rather than for enclitics used by Ghomeshi (2001).

Chapter 1: Introduction

1.1 Introduction

This thesis presents an analysis of number marking in Modern Persian. The core discussion is clustered around the roles of number marking and its relevance to inflectional and derivational plural morphology in Persian. I will show how the properties of the plural marker in Persian can account for inflectional as well as derivational number marking.

In order to investigate the characteristics of Persian number marking, I assume the two parameters of plural marking proposed by Wiltschko (2007, 2008): number merging as a head and number adjoining as a root modifier. Inflectional plural marking merges as head of the functional category Number Phrase (NumP) while derivational plural marking adjoins nominal roots as a modifier (Wiltschko, 2007, 2008).

Taking the properties and roles of number marking in Persian into account, I will show that number marking in Persian is generally inflectional, being generated in the head of the functional category NumP. Moreover, Persian turns out to be a classifier language in which classifiers are in complementary distribution with plural marking. Following Borer (2005), who argued that classifiers are in complementary distribution with number in Armenian, I will show that either the plural marker or classifiers occupy the head of NumP in Persian.

Although I assume the two parameters of plural marking in the framework of principles and parameters (P&P) in the Minimalist Program (Chomsky, 1995a, 1998, 1999, 2000, 2001), I argue that Persian plural marking functions independently from Wiltschko's (2008) parameter setting (number as a functional head as opposed to number as a modifier). In fact, I disagree with Wiltschko because I assume that plural marking in Persian cannot belong to either inflectional or derivational plural morphology. Rather, following Distributed Morphology, I do not split morphology to inflectional and derivational. I assume that plural morphology in Persian functions differently in contexts. Moreover, following the claim by Booij (1993, 1995) that inflectional morphology can be used contextually or inherently, I argue that plural marking in Persian is inflectional while number is a functional head; however, under certain circumstances the plural marker in Persian can be used inherently as a modifier adjoining nominal roots.

In addition, I assume that in the framework of the neo-constructionist models by Borer (2005) grammatical categories are described with regard to structure, not vice versa. Also, following Borer's *exo-skeletal* model, I assume that syntactic properties are not properties of the listemes, but they are properties of structures. Hence, I assume the properties of plural morphology on the basis of the properties of structures.

Based on the empirical evidence and the distribution and properties of number marking in Persian, in this thesis I attempt to provide answers to the following central questions on number marking in Persian: (i) Is the nature of the plural marker in Persian inflectional or derivational?; (ii) Does the functional category

Num(ber) project in Persian?; (iii) Does a grammaticized mass/count distinction exist in Persian?; (iv) Does the plural marker in Persian adjoin nominal roots as a root modifier?; (v) Do classifiers in Persian function as grammatical number?; (vi) What is the relationship between bare singulars/plurals and the projection of NumP in Persian?

In connection with these research questions, I provide the following proposals:

- I. Plural marking in Persian is inflectional but with inherent residues.
- II. The functional category Number projects in Persian, and the head of this projection is occupied either by the plural marker or by classifiers.
- III. A grammaticized mass/count distinction exists in Persian because number marking in Persian is mainly inflectional and because the functional category NumP projects in Persian.
- IV. When plural marking is derivational in Persian, the plural marker adjoins nominal roots as a modifier.
- V. Grammatical classifiers, like grammatical number, have roles in number marking in Persian.
- VI. The presence of bare nouns in certain syntactic positions in Persian is allowed because Num and Agr are not fused.

§1.2 presents the puzzles of the distribution of number marking in Persian in connection with these research questions and proposals.

1.2 The puzzles

The distribution of plural marking in Persian provides the core puzzles of this thesis. The first puzzle is connected to the first research question questioning whether plural marking in Persian is inflectional or derivational in nature. Wiltschko (2008) introduced some properties of inflectional plural marking, to be discussed in detail in Chapter 2. Although most of the characteristics of plural marking in Persian reveal that number marking is inflectional, some number marking properties suggest that it is derivational as well. One of the characteristics of inflectional plural marking is agreement. Subject-verb agreement of animate subjects², as in (1), is an indication that plural marking in Persian is inflectional:

(1) a. u kar=mi-kon-æd.

he/she work=DUR-do.PRES-3SG

‘He/She works.’

b. ma zood sobhane xord-im.

we early breakfast eat.PAST-3PL

‘We ate breakfast early.’

² If subjects are inanimate in Persian, subject-verb agreement is optional, as in (i):

(i) a. barg-ha zærd=šod-ænd.
leaf-PL yellow=become.PAST-3PL
‘The leaves turned yellow.’

b. barg-ha zærd=šod.
leaf-PL yellow=become.PAST-3SG
‘The leaves turned yellow.’

Although examples (1a) and (1b) and the tests outlined in Chapter 2 show that agreement is one of the characteristics of Persian number marking, in some cases there is no agreement. For instance, there is no agreement between unmarked demonstratives and plural nouns, as in (2):

- | | |
|--------------------|----------------|
| (2) a. in ketab | b. in ketab-ha |
| this book | this book-PL |
| ‘this book’ | ‘these books’ |
| | |
| c. *in-ha ketab-ha | |
| this-PL book-PL | |

The diagnostic tests for characteristics of inflectional plural marking, discussed in Chapter 2, reveal that Persian plural marking is inflectional, yet there are some derivational residues. Hence, the puzzle is whether Persian number marking is a functional head or whether it is a modifier. In order to solve this puzzle, I argue that Wiltschko’s (2008) number marking parameters, which are plural marking as ‘functional head’ as opposed to plural marking as ‘modifier’, are too strict. Rather, I adopt Booij’s (1993, 1995) proposal on *contextual* inflectional morphology and *inherent* inflectional morphology and predict that plural marking in Persian is inflectional, as in English and Ojibwe, but that it has some inherent properties. I provide the verification of this hypothesis in Chapter 2.

The second puzzle of this thesis is why pluralisation of mass nouns, particularly with a ‘large amount of mass’ interpretation, is possible in Persian. This puzzle is connected to the research question of whether a grammaticized mass/count distinction exists in Persian. Even though the pluralisation of mass nouns with a ‘large amount of mass’ interpretation would suggest that number marking in Persian is derivational rather than inflectional and that the plural marker is a modifier rather than a functional head, it would be a hasty conclusion to suggest that there is no grammaticized mass/count distinction in Persian.

The distribution of plural marking in Persian reveals that some mass nouns such as *šir* ‘milk’ can be pluralized as in *šir-ha* ‘milk-PL.’ The plural of such mass nouns can induce a ‘kind,’ or ‘portion’ reading, as in (3) and (4), respectively:

(3) *mæn šir-ha-ye tæʔmdar ra doost=næ-dar-æm.*

I milk-PL-EZ flavoured OM like=NEG-have.PRES-1SG

‘I don’t like flavoured milks.’

(4) *šir-ha ra be-gozar ruye miz.*

milk-PL OM IMP-put.2SG on table

‘Put the milks on the table.’

The plural marking of mass nouns with a ‘kind’ or ‘portion’ reading in Persian is similar to plural marking of mass terms in English. Although plural marking of mass nouns is not common in English, plural marking of some mass nouns such as

‘water’ with a ‘kind’ or ‘serving/portion’ reading is possible in English, as in (5a) and (5b), respectively. The plural of ‘water’ in idiomatic expressions in British English is also possible, as in (5c):

- (5) a. There are only three waters available (tap, still, and sparkling water)
- b. John ordered three waters (i.e. glasses, bottles etc...)
- c. Matilda’s waters broke.

(Tsoulas, 2007:3)

The pluralisation of mass nouns with a ‘large amount of mass’/‘abundance’³ reading in Persian is possible, as in (6). In this example, the singular and plural nouns have almost the same interpretation; however, the plural of mass nouns induces that there is more spreading, gathering, or pouring of the mass noun (Sharifian & Lotfi, 2003).

- (6) væqti dašt keyk dorost-mi-kærd, šir(-ha)-ro rixt
when had cake make-DUR-do-PAST.3SG, milk(-PL)-OM spill.PAST-3SG
ru-ye zæmin.
on-EZ floor

‘When he/she was making cake, he/she spilt the milk on the floor.’

In order to provide an answer to the second puzzle of this thesis, I propose that there is a mass/count distinction in Persian even though plural marking of mass

³ This term is used by Mathieu (2011).

nouns with a ‘large amount of mass’ interpretation is possible in Persian. I argue that the inherent use of Persian plural marking results in plural marking of mass nouns with a ‘large amount of mass’ reading. In spite of this, I argue that generally plural marking in Persian is used contextually, which results in a mass/count distinction in Persian. I show in Chapter 3 how this hypothesis is verified.

The third puzzle revolves around the fact that Persian turns out to be a classifier language. The puzzle is why there is co-occurrence restriction of the plural marker and classifiers in Persian. This puzzle is connected to the research question regarding whether classifiers in Persian function as grammatical number. The presence or absence of the plural marker and classifiers and the co-occurrence restriction of the plural marker and the classifiers are shown as in (7a) through (7d):

(7) a. moæ?lem-ha zud amæd-ænd. No cardinal, no classifier, plural

teacher-PL early come.PAST-3PL

‘The teachers came early.’

b. do (ta) moæ?lem zud amæd-ænd. Cardinal, (classifier), no plural

two (CL) teacher early come.PAST-3PL

‘Two teachers came early.’

c. *do moæ?lem-ha zud amæd-ænd. Cardinal, no classifier, plural

two teacher-PL early come.PAST-3PL

‘Two teachers came early.’

d. do ta moæ?lem(-ha) zud amæd-ænd. *Cardinal, classifier, (plural)*

two CL teacher(-PL) early come.PAST-3PL

‘The two teachers came early.’

The absence of a classifier in (7a) is formal. The presence of the default classifier *ta*, as in (7b), is almost obligatory in the informal register, yet its absence is quite formal. In (7c), there is a formal absence of a classifier. The co-occurrence of the plural marker and classifiers, as in (7d), is quite informal in Persian. However, in order to mark definiteness in formal register, a demonstrative must be used⁴.

In order to provide an answer to the puzzle of classifiers and number in Persian, I follow Borer (2005) who argued that classifiers in Armenian are in complementary distribution with number while occupying the head of the same functional category. Since complementary distribution of classifiers and number is a universal property, I predict that classifiers and plural marking in Persian both occupy the head of NumP while being in complementary distribution. I argue in Chapter 4 that this hypothesis is verified.

The final puzzle of this thesis is the relationship between the presence of bare nouns in Persian and the projection of NumP. Bare singulars/plurals in Persian can appear in subject, object, or predicate positions with different interpretations. The absence of plural marking in predicate positions is shown in (8a) and (8b):

⁴ (i) an/un do ta moæ?lem(-ha) zud amæd-ænd.
that two CL teacher(-PL) early come.PAST-3PL
‘Those two teachers came early.’

(8) a. anha xæbærnegar hæst-ænd.

they reporter be.PRES-3PL

‘They are reporters.’

b. ma bazærgan hæst-im.

we businessman be.PRES-1PL

‘We are businessmen.’

A bare singular in subject position with a definite interpretation is shown in (9):

(9) bæčče zud mi-xab-ænd.

child early DUR-sleep.PRES-3SG

‘The child sleeps early.’

To provide an answer to the puzzle of bare nouns in Persian, I propose that one or both of the two morpho-syntactic parameters known as the ‘Free Agr’ parameter and the ‘empty determiner’ parameter introduced by Schmitt and Munn (2000) are required in order to have bare nouns in Persian. The presence of bare singulars in predicative positions in Persian, as in (8a) and (8b), is possible because of the Free Agr parameter. I argue that in predicative positions in Persian, Agr is present, but the interpretable Num is absent. The presence of the definite bare singulars, as in (9), is possible because of the empty determiner parameter. I argue that bare

singulars with definite interpretations belong to category DP, but the head of D is null. I present the verification of this hypothesis in Chapter 5.

In order to provide answers to the questions of the core discussion of this thesis mentioned above, I present the main proposals in the following section.

1.3 Main proposals

Considering the nature of plural marking in Persian, I compare and contrast the characteristics of Persian plural marking to the properties of inflectional plural marking introduced by Wiltschko (2008). In Wiltschko's parameter setting (2007, 2008) number marking is either *inflectional* – resulting in merging number as a functional head, or *derivational* – resulting in adjoining number as a root modifier, as discussed in §1.5.1. However, Persian, like Ojibwe (Mathieu, 2009) and some Indo-European languages, is revealed to have not only inflectional number marking characteristics but also some residues of derivational number marking. Consequently, following Booij (1993, 1995) that inflectional morphology can be used contextually as well as inherently, I propose that the properties of Persian plural marking are mainly compatible with those of inflectional plural marking while some are in line with the properties of derivational plural marking. Assuming that inflectional number marking merges as a head, namely, the head of the functional category NumP, I propose that the functional category NumP projects in Persian, and that the plural marker, being inflectional, merges as the head of NumP. Nevertheless, because Persian plural marking has some properties of derivational

plural marking, I propose that the plural marker also adjoins as a root modifier under certain conditions.

Having hypothesized that the functional category NumP projects in Persian, and that inflectional plural marking in Persian merges as the head of NumP, I propose that number marking in Persian behaves the same as number marking in English (Wiltschko, 2007, 2008) and in Ojibwe (Mathieu, 2007, 2008, 2011) where grammatical number occupies the head of NumP. Furthermore, I propose that grammatical classifiers as number morphology in Persian as well as in Chinese (Cheng & Sybesma, 1999; Wiltschko, 2007, 2008) occupy the same head. Wiltschko (2007) argues that number marking merging as a NumP head results in a grammaticized mass/count distinction; therefore, I propose that number marking in Persian results in a grammaticized mass/count distinction. Borer (2005) argues that the head of NumP can be occupied either by plural marking or by classifiers, and that if these two occur in a language, they are in complementary distribution. Because Persian is a classifier language, as are Chinese-like languages, and because there is co-occurrence restriction of plural marking and classifiers in Persian⁵, I propose that the head of NumP in Persian is occupied either by grammatical number or by grammatical classifiers while both individualize nouns. Therefore, both classifiers and plural marking are responsible for the existence of a mass/count distinction in Persian.

However, based on the empirical evidence of mass noun plural marking and mass/count underspecification of nominal roots, following Wiltschko (2007, 2008),

⁵ In informal register of Persian, the plural marker and the classifier *ta* co-occur yielding a definite reading.

I propose that under these circumstances the plural marker as a modifier adjoins nominal roots.

Assuming that plural marking in Persian is inflectional but with derivational residues while having individualizing and modificational roles, respectively, my proposal strongly departs from Wiltschko's number marking parameter setting, namely, either the plural marker merges as a head or adjoins as a modifier. Rather, I propose that plural marking in Persian is inflectional when the plural marker is a functional head, while it has some inherent residues when it has modificational roles. In other words, I do not follow Wiltschko in splitting plural morphology to either inflectional or derivational. Rather, I assume that both inflectional and derivational plural morphology can be used in Persian, following Booij (1993, 1995).

Assuming that classifiers in Persian occupy the head of NumP and have the role of individualizing nouns while being in complementary distribution with plural marking to occupy the head of NumP, I further discuss the optionality of classifiers in an indefinite noun phrase having a [Card + (CL) + N] combination. I argue that even if there is no full classifier in this combination, plural marking does not occur. As a result, I propose that the restriction of plural marking occurrence in this combination is because the head of NumP is occupied either by a full classifier or by an empty classifier. Nevertheless, a classifier can co-occur with the plural marker in a definite noun phrase (Gebhardt, 2008; Ghaniabadi, 2010) having a combination of [Card + CL + N + (PL)]. Because plural marking in this combination is optional, and because plural marking and classifiers cannot both

occupy the head of NumP at the same time, I propose that the plural marker as a root modifier adjoins the nominal root to induce definiteness. The proposal that plural marking in Persian can also be modificational is in line with derivational plural morphology (Wiltschko, 2007, 2008) having the properties of syntactic adjuncts.

In connection with the presence/absence of NumP in Persian, I investigate the characteristics of bare singulars/plurals in Persian. In order to analyze the distribution of bare singulars/plurals in Persian, I assume the two morpho-syntactic parameters introduced by Schmitt and Munn (2000), known as the Free Agr parameter and the empty determiner parameter. I assume that these two parameters are required to have bare singulars/plurals in Persian. I argue that the independent functions of Num/Agr heads in Persian are due to the Free Agr parameter. In a predicative position in Persian, the interpretable Num feature can be missing when the predication subject has an interpretable number feature. Hence, I propose that the absence of the interpretable number in a predicative position in Persian is the consequence of the Free Agr parameter. I also argue that when bare singulars are antecedents of singular/plural pronouns and appear in argument position, they are underspecified with regard to number. Hence, I propose that because of the Free Agr parameter, there is no projection of number in these argument positions.

Following Ghomeshi (2008), I assume that in Persian definite bare singulars/plurals belong to the DP category with D^0 -heads. This discussion is compatible with the discussion of the empty determiner parameter introduced by Schmitt and Munn (2000), which results in having definite bare singulars/plurals

with empty Ds. As a result, I propose that because of the empty determiner parameter, Persian definite bare singulars/plurals in argument positions belong to the DP category while having have empty Ds.

Nevertheless, in an object position in Persian, the object marker *ra* accompanies a definite singular/plural while inducing different interpretations. In connection with this, I assume Vergnaud and Zubizarreta's (1992) discussion that a definite determiner can be expletive if it is type-denoting; otherwise, a definite determiner induces a token reading. Consequently, I propose that in Persian, an empty definite determiner accompanying a *ra*-marked object is expletive provided that it induces a type interpretation; nevertheless, a token reading implies the existence of an empty definite determiner.

In the next section, I provide background on Persian, the language under study in this thesis, with emphasis on plural marking in Persian.

1.4 Background: Modern Persian

The language under discussion is the Persian language belonging to the West Iranian languages as a subcategory of the Indo-Iranian languages, which are part of the Indo-European languages. The dialect of Persian under study is Standard Modern Persian, spoken in Tehran and the official language of Iran. The registers considered in this thesis are formal and colloquial Modern Persian, henceforth, Persian.

In this section, I present some characteristics of plural marking, classifiers, and the distribution of bare singulars/plurals in brief, including a discussion of the object marker *ra*, in connection to the discussions with this thesis.

1.4.1 Persian plural markers

The two most common plural markers in Persian are the suffixes *-ha* and *-an*. In Modern Persian (in both colloquial and written language), the plural marker *-ha* occurs with all types of nouns, including abstract nouns, as in (10), animate nouns, as in (11), and inanimate nouns, as in (12):

abstract nouns + -ha

(10) a. ægl-ha

wisdom-PL

b. xubi-ha

goodness-PL

c. bædi-ha

badness/wickedness-PL⁶

animate nouns + -ha

(11) a. xanum-ha

lady-PL

‘ladies’

b. kælaq-ha

crow-PL

‘crows’

c. pesær-ha

boy-PL

‘boys’⁷

⁶ Some more examples of plural marking of abstract nouns with *-ha* are as follows:

abstract nouns + -ha

d. iman-ha
faith-PL

e. xæšm-ha
anger-PL

inanimate nouns + -ha

(12) a. sæng-ha

stone-PL

‘stones’

b. medad-ha

pencil-PL

‘pencils’

c. kuh-ha

mountain-PL

‘mountains’

In colloquial and written Persian, the plural marker *-an* occurs with animate nouns, such as nouns used for humans, as in (13), and nouns used for animals, as in (14). The plural marker *-an* is not fully productive, even with animate nouns, such as (14a):

⁷ Some more examples of plural marking of animate nouns with *-ha* are as follows:

animate nouns +-ha

d. šir-ha

lion-PL

‘lions’

e. gusfænd-ha

sheep-PL

‘sheep’

animate nouns (used for humans)

+ -an

(13) a. doxtær-an

girl-PL

‘girls’

b. pesær-an

boy-PL

‘boys’

c. zæn-an

woman-PL

‘women’

animate nouns (used for animals)

+ -an

(14) a. janevær-an

animal-PL

‘animals’

b. kæbutær-an

pigeon-PL

‘pigeons’

c. šotor-an

camel-PL

‘camels’⁸

⁸ Some more examples of plural marking of animate nouns (used for humans and animals) with *-an* are as follows:

animate nouns (used for humans)+ -an

d. mærd-an
man-PL
‘men’

e. xahær-an
sister-PL
‘sisters’

f. kudæk-an
child-PL
‘children’

animate nouns (used for animals) + -an

d. morq-an
bird-PL
‘birds’

e. gonješk-an
sparrow-PL
‘sparrows’

f. æsb-an
horse-PL
‘horses’

The plural markers *-ha* and *-an* can occur with some nouns used for plants, as in (15):

- (15) a. *deræxt-ha*; *deræxt-an*
tree-PL ; tree-PL
'trees'
- b. *giyah-ha*; *giyah-an*
plant-PL; plant-PL
'plants'
- c. *nilufær-ha* ; *nilufær-an*
water lily-PL; water lily-PL
'water lilies'

If an animate noun (or an adjective used as a noun) ends in /a/ or /u/, /y/ is added to the plural marker *-an*, changing it to *-yan*, as in (16):

- (16) a. *dana-yan*
wise-PL
'the wise'
- b. *ašena-yan*
acquaintance-PL
'acquaintances'
- c. *xubru-yan*
beautiful-PL
'the beautiful'
- d. *soxængu-yan*
spokesman-PL
'spokesmen'

However, if a noun ends in /e/, /g/ is added to the plural marker *-an*, changing it to *-gan*, as in (17):

- | | |
|---------------------|---------------|
| (17) a. ferešte-gan | b. setare-gan |
| angle-PL | star-PL |
| ‘angles’ | ‘stars’ |

In addition to the aforementioned plural markers in Persian, the Arabic plural markers, such as the plural marker *-at*, occur with Arabic borrowed nouns or adjectives replacing nouns, as in (18):

- | | |
|-------------------|----------------|
| (18) a. heyvan-at | c. tæmayol-at |
| animal-PL | tendency-PL |
| ‘animals’ | ‘tendencies’ |
| b. estehkam-at | d. emtehan-at |
| fortification-PL | examination-PL |
| ‘fortifications’ | ‘examinations’ |

The plural marker *-at*⁹ can also occur with some Persian nouns, as in (19):

⁹ If a noun ends in /a/, /u/, or /i/, /j/ is added to the plural marker *-at*, changing it to *-jat*, as in (i), denoting different groups of a particular noun:

- | | |
|--------------------|-------------|
| (i) a. morræba-jat | b. daru-jat |
| jam-PL | medicine-PL |
| ‘jams’ | ‘medicines’ |
| c. sæbzi-jat | |
| vegetable-PL | |
| ‘vegetables’ | |

- | | |
|----------------|------------|
| (19) a. baq-at | b. deh-at |
| garden-PL | village-PL |
| ‘gardens’ | ‘villages’ |

Another Arabic plural marker is *-in*, which occurs with human nouns, as in (20):

- | | |
|--------------------|---------------|
| (20) a. moæ?lem-in | b. mohaqeq-in |
| teacher-PL | researcher-PL |
| ‘teachers’ | ‘researchers’ |
|
 | |
| c. motærjem-in | d. kašef-in |
| translator-PL | discoverer-PL |
| ‘translators’ | ‘discoverers’ |

The Arabic plural marker *-yun* occurs with nouns ending in /i/, as in (21), but it is not fully productive:

- | | |
|----------------------|---------------|
| (21) a. enqelabi-yun | b. rohani-yun |
| revolutionist-PL | cleric-PL |
| ‘revolutionists’ | ‘clerics’ |

Most nouns, including Arabic borrowed nouns, that occur with the plural markers other than *-ha* can also occur with the Persian plural markers *-ha* as a

optional; however, in the informal register, the use of classifiers is obligatory in most cases, as in (23b):

(23) a. se (qætte) zæmin xærid-im.
three (CL^{piece}) lænd buy-PAST.1PL
'We bought three pieces of land.'

b. čahar ta sib xord-æm.
four CL apple eat-PAST.1SG
'I ate/had four apples.'

(24) a. *se (qætte) zæmin-ha xærid-im.
three (CL^{piece}) lænd-PL buy-PAST.1PL

b. *čahar (ta) sib-ha xord-æm.
four (CL) apple-PL eat-PAST.1SG

The co-occurrence of the classifiers with the plural marking is possible with definite reading in informal register, as in (25):

(25) a. se qætte zæmin-ha-ro xærid-im.
three CL^{piece} lænd-PL-OM buy-PAST.1PL
'I bought the three pieces of land.'

b. čahar ta sib-ha-ro xord-æm.

four CL apple-PL-OM eat-PAST.1SG

‘I ate/had the four apples.’

The classifier *ta*, as used in (25b), is a default classifier that co-occurs with count nouns and with some mass nouns, as in (26a) and (26b), respectively. This default classifier is used mostly in informal and colloquial registers of Persian.

(26) a. čahar ta livan

four CL glass

‘four glasses’

b. do ta čay

two CL tea

‘two teas’

Ghaniabadi (2010), following Samiiian (1983), assumes that there are three types of classifiers in Persian. The first type is *true classifiers*, used with count nouns, while the second and the third are *measure nouns* and *group nouns*, which are used with mass nouns. These are listed in (27):

(27) TRUE CLASSIFIERS

-tâ	‘unit’, used with all count nouns
nafar	‘person’
jeld	‘unit’, used for books
pors	‘unit’, used for meals

GROUP NOUNS

daste	‘bunch’
goruh	‘group’
fenjun	‘cup’
qâšoq	‘spoon’

MEASURE NOUNS

metr	‘metre’
kilo	‘kilogram’
litr	‘litre’

(Ghaniabadi, 2010:25)

1.4.3 Distribution of bare singulars/plurals

Persian bare singulars and bare plurals can occur in various syntactic positions, including subject, object, and predicative positions. Persian does not have a definite determiner, with the exception of the stressed *-e*¹³; however, the reading of a bare singular/plural in a syntactic position depends on the context; therefore, bare

¹³ Ghomeshi (2003) argues that in Persian colloquial speech, definiteness is realized by a stressed suffix marker, *-e* or *-æ* if it occurs non-word-finally. In any position in syntax, the stressed suffix occurs with nouns:

- (i) a. doxtær-e amæd.
girl-DEF come.PAST.3SG
‘The girl came.’
b. ketab-o be doxtær-e dad-æm.
book-OM to girl-DEF give.PAST-1SG
‘I gave the book to the girl.’
c. doxtær-æ-ro did-æm.
girl-DEF-OM see.PAST-1SG

(Ghomeshi, 2003: 68)

singulars/plurals in subject position, as in (28) and (29), have different interpretations:

(28) a. **šagerd** be komæk-e moæ?lem ehtiyaj=dar-æd.

student to help-EZ teacher need=have.PRES-3SG

‘A student needs a teacher’s help./The student needs the teacher’s help.’

b. **šagerd-ha** be komæk-e moæ?lem ehtiyaj=dar-ænd.

student-PL to help-EZ teacher need=have.PRES-3PL

‘Students need a teacher’s help./The students need the teacher’s help.’

(29) a. **bačče** bayæd zud be-xab-æd.

child must early SBJ-sleep.PRES-3SG

‘A child must go to bed early./The child must go to bed early.’

b. **bačče-ha** bayæd zud be-xab-ænd.

child-PL must early SBJ-sleep.PRES-3PL

‘Children must go to bed early./The children must go to bed early.’

However, Persian singulars or plurals in subject positions can be followed by the enclitic *-i*¹⁴ inducing an indefinite reading, as in (30):

¹⁴ The enclitic *-i* heads a QP (Ghameshi, 2003).

(30) a. hæz ruz **pir-e-mærd-i** æz inja ruzname mi-xær-æd.
every day old-EZ-man-IND from here newspaper DUR-buy.PRES-3SG

‘Everyday an old man buys a newspaper from here.’

b. hæz ruz **pir-e-mærd-ha-yi** æz inja ruzname mi-xær-ænd.
every day old-EZ-man-PL-IND from here newspaper DUR-buy.PRES-
3PL

‘Everyday some old men buy newspapers from here.’

Ghameshi (2003) argues that in direct object positions the Case marker *ra*¹⁵ distinguishes Persian non-referential bare singulars, as in (31a), from definite bare singulars, as in (31b):

(31) a. **ketab** xær-id.
book buy.PAST-3SG

‘He/She bought a book/books.’

b. **ketab-ra** xær-id.
book-OM buy.PAST-3SG

‘He/She bought the book.’

¹⁵ Although the literature on *ra* is abundant, there is no definite consensus on the nature of this. Dabir-Moghaddam (1992) proposes that *ra* is a marker of secondary topicalization. Karimi (1989, 1990, 2003c) classifies *ra* as a specificity marker following a definite or indefinite DP. Furthermore, Ghameshi (1997b, 2003) argues that *ra* is a Case marker heading a Case Phrase. Following Ghameshi, Ganjavi (2007) argues that, as a case marker, *ra* occurs only with DP direct objects.

Bare plurals in object positions are quite marked and have a very restricted use. They carry a particular emotional connotation, an element of surprise or amazement, as in (32):

(32) **ketab-ha** xand¹⁶.

book-PL read.PAST-3SG

‘He/She read all sorts of books.’

Ghomeshi argues that bare plural in direct object positions appearing with the object marker *ra* are definite DPs, as in (33). Such bare plurals are not on par with bare plurals which are marked, as in (32). They are asymmetrical and the difference between these two bare plurals is far beyond definiteness.

(33) **ketab-ha-ra** xær-id.

book-PL-OM buy.PAST-3SG

‘He/She bought the books.’

As with nouns in subject position, the indefinite enclitic *-i* can accompany Persian singulars in object positions, as in (34a). In informal Persian, the quantifier

¹⁶ The bare plural in (32) has the following connotation:
‘You can’t imagine how many sorts of books she/he read.’

čænd ‘some’ followed by the classifier *ta* induces indefiniteness, as in (34b). In formal¹⁷ Persian, the classifier is absent, as in (34c):

(34) a. **ketab-i** *nevešt*.

book-IND write.PAST-3SG

‘He/She wrote a book

b. *čænd* *ta* **ketab** *nevešt*.

several CL book write.PAST-3SG

‘He/She wrote some books.’

c. *čænd* **ketab** *nevešt*.

some book write.PAST-3SG

‘He/She wrote some books.’

According to Ghomeshi (2003), the enclitic *-i* follows nouns entailing that the nouns are referential. Sometimes the noun phrase is understood as ‘specific¹⁸’, followed by the object marker *ra*, as in (35):

¹⁷ The occurrence of Persian singulars with the enclitic *-i* in object positions, as in (34a), is very formal. In colloquial register, the cardinal *ye/yek* induces indefiniteness:

(i) a. *ye ketab nevešt*.

one book write.PAST-3SG

‘He/She wrote a book.’

b. *ye ketab-i nevešt*.

one book-IND write.PAST-3SG

‘He/She wrote a book.’

¹⁸ Referring to footnote 13, Karimi (1989, 1990, 2003c) argues that *ra* is a specificity marker, which follows definite or indefinite DPs.

(35) **ketab-i-ra** nevešt.
book-IND-OM write.PAST-3SG
'He/She wrote a (specific) book.'

Bare singulars can appear in predicative positions in Persian, as in (36a) and (37a); however, plural marking is not allowed in such constructions, as shown in (36b) and (37b), if the intended predicative meanings are for (36b) and (37b) are: 'We are doctors.' and 'They are journalists.', respectively:

(36) a. ma **doktor** hæst-im.
we doctor be.PRES-1PL
'We are doctors.'

b. *ma **doktor-ha** hæst-im.
we doctor-PL be.PRES-1PL

(37) a. anha **xæbærnegar** bud-ænd.
they journalist be.PAST-3PL
'They were journalists.'

b. *anha **xæbærnegar-ha** bud-ænd.
they journalist-PL be.PAST-3PL

Nevertheless, Ghemehsi (2003) argues if the plural marker in predicative nominals is used referentially, it induces equative reading, as in (38a) and (38b) where plural marking is allowed:

(38) a. ma **doktor-ha** hæst-im.

we doctor-PL be.PRES-1PL

‘We are the doctors.’

b. anha **xæbærnegar-ha** bud-ænd.

they journalist-PL be.PAST-3PL

‘They were the journalists.’

1.5 Theoretical framework

As the theoretical framework of this thesis, I adopt the principles and parameters (P&P) of the Minimalist Program (Chomsky, 1995a, 1998, 1999, 2000, 2001).

Chomsky (1995) stated that “there are universal principles and a finite array of options as to how they apply (parameters), but no language-particular rules and no grammatical constructions of the traditional sort within or across languages” (p. 6).

Prior to the Minimalist Program, following the Extended Standard Theory (EST), Chomsky (1995) assumed levels of representation at the level of Logical Form (LF), the level of Phonetic Form (PF), and the level of D-Structure relating the lexicon and the computational system. LF and PF specify meaning and sound

aspects, respectively. These levels are connected by an intermediate level as S-Structure, shown in (39):

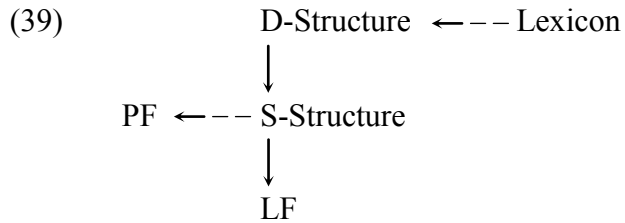

(Chomsky, 1995:22)

However, the Minimalist Program (Chomsky, 1998, 1999) identifies two interface levels: LF (conceptual-intentional) and PF (articulatory-perceptual). The model of grammar, including PF and LF, presented by Embick and Noyer (2006) is shown in (40):

(40) The Grammar

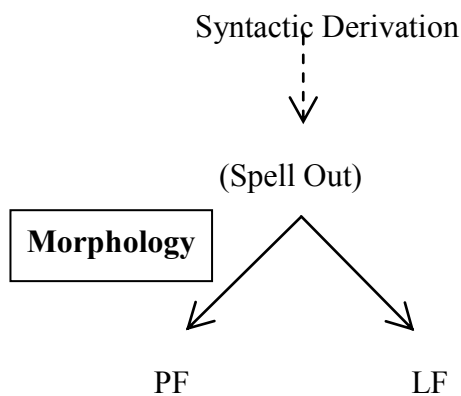

(Embick & Noyer, 2005:291)

There are three core operations in the Minimalist Program, *Merge*, *Agree*, and *Move*. *Merge* is an operation that builds larger structure out of already constructed smaller ones. Two syntactic objects (α , β) are taken and a larger structure, $K(\alpha, \beta)$ is formed via *Merge* (Chomsky, 1998).

Agree is a relation between probe P, having unvalued features, and goal G, having unvalued features, deleting uninterpretable features¹⁹ on condition there is appropriate relationship between P and G. (Chomsky, 1999, 2001).

The operation *Move*²⁰ or *internal Merge* (Chomsky, 2001) combines *Merge* and *Agree*.

Having discussed some core ideas on the Minimalist Program, in the following section, I present a discussion of plural marking parameters in the framework of principles and parameters in the Minimalist Program.

1.5.1 Plural marking parameters

Chomsky (1995) distinguishes between inflectional morphology and derivational morphology because inflectional morphology is part of syntax, while derivational morphology is part of the lexicon.

Wiltschko (2008) argues that under this framework the feature specifications of inflectional morphology can be considered in the projection of a functional

¹⁹ Lexical items are composed of two types of feature, interpretable and uninterpretable. At the interface external system, interpretable features are legible. Uninterpretable features, however, are unvalued. They are erased in the LF course of computation (Chomsky, 1998).

²⁰ Chomsky (1998) stated the following:

The operation *Move* establishes agreement between α and F and merges $P(F)$ to αP , where $P(F)$ is a phrase determined by F (perhaps but not necessarily its maximal projection) and αP is a projection headed by α . $P(f)$ becomes $\text{Spec-}\alpha$. Let us refer to *Move* of P to $\text{SPEC-}\emptyset$ as A-movement, where \emptyset is an agreement feature (\emptyset -feature); other cases are A'-movement. (p. 14)

category; moreover, many inflectional categories are mainly syntactic categories. Following Ritter (1995), Wiltschko (2008) analyzes the properties of inflectional number marking generated as a head of a syntactic category.

Following cross-linguistic investigations, Ritter (1995) stated that an analysis of the specifications of noun phrases suggested that the category NP is dominated by one functional projection or more. Ritter argued that the specification of number in different languages is analyzed as a syntactic category, namely, a Number Phrase (NumP) functional category heading a projection independently, which dominates NP. For Hebrew, Ritter argued that NumP, as an intermediate projection between DP and NP, includes number specification.

Ritter assumes that in Hebrew affixation, including number affixation, occurs in either of these components: the lexical or syntactic component. Therefore, while lexical stems are where some affixes originate, syntactic projection heads are places for other affixes to develop, as in (41) and (42), respectively. Affixes that are generated as syntactic heads attach to heads as a result of head movement.

(41) Lexical Affixation

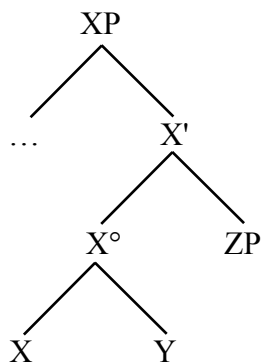

(Ritter, 1995:408)

(42) Syntactic Affixation

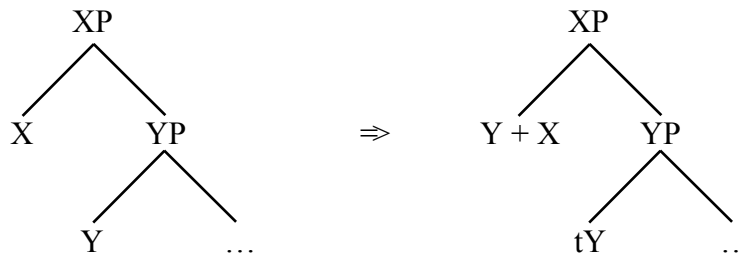

(Ritter, 1995:409)

Nouns that indicate periods of time in Hebrew have plural and dual affixes, which are in complementary distribution, yet both appear as heads of NumP. In (43), the dual suffix *-ayim* ‘two’ generated as the head of NumP and added to the noun *xodeS* ‘month’ by head movement has the dual form *xodSayim* ‘two months’:

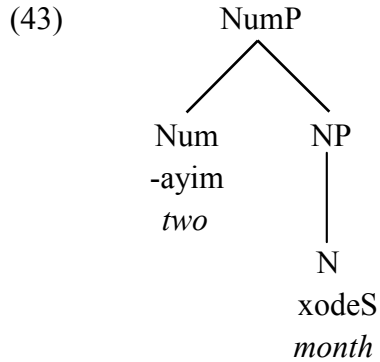

(Ritter, 1995: 411)

The evidence in Hebrew reveals that gender affixes are lexical, appearing on NP heads, while number affixes are syntactic, appearing on NumP heads. Definiteness specification, however, is on DP heads, as shown in (44):

(44)

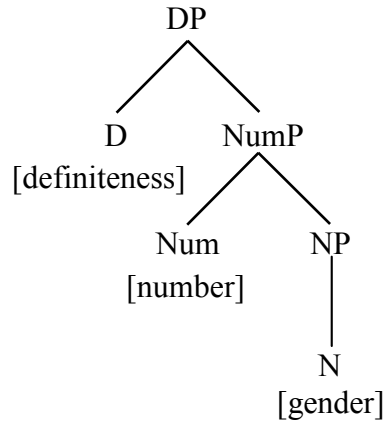

(Ritter, 1995:418)

Having discussed plural marking as a syntactic projection head, I follow Wiltschko (2008) in assuming the plural marking parameters and their variations presented in (45):

(45) *Parameters of plural marking:*

a. How is PLURAL merged?

i) as head

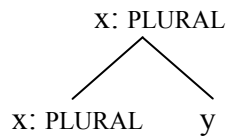

ii) as modifier (adjoined)

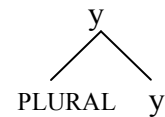

b. Where is PLURAL merged?

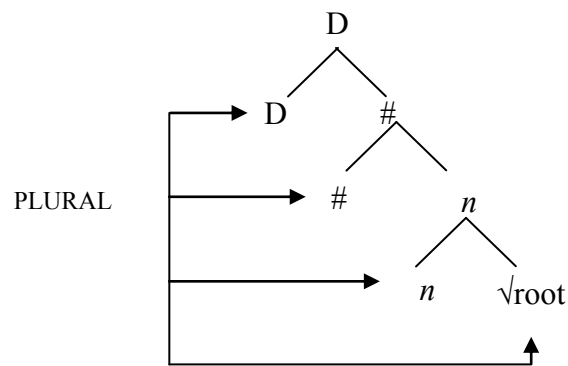

(Wiltschko, 2008:688)

Following Wiltschko (2008), I assume that plural marking may adjoin as *n*-heads, #-heads, or D-heads. Moreover, I assume that in spite of the fact that plural markers merging as heads have the syntactic properties of heads, plural markers adjoining to roots have adjuncts' syntactic characteristics; namely, they modify roots.

In spite of this, I want to argue that the number marking parameter setting by Wiltschko (2008) of 'functional head' versus 'modifier' is too strict. Rather, I assume Booij's (1993, 1995) view of inflectional morphology as inherent and contextual inflection, discussed in the following section.

1.5.2 Inflectional morphology

Booij (1993, 1995) argues against the split morphology of Perlmutter's (1988) and Anderson's (1992) assumption that morphology is split into derivation as a pre-syntactic component and inflection as a post-syntactic component. Rather, Booij (1995) introduces two types of inflectional morphology, namely, *inherent* inflection and *contextual* inflection. Inherent inflection, which is independent from syntax, may have some connection to syntax. Inherent inflection, being similar to derivation, feeds word formation and is included in derivation, according to Booij (1993, 1995). An example of inherent inflection for nouns is number, and examples for verbs are tense and aspect. In contrast, Booij (1993, 1995) argues that contextual inflection, being peripheral to inherent, is determined by syntax. Examples of contextual inflection for verbs are person and number, and examples for nouns are case markers.

Following Booij (1993, 1995), I do not split morphology to derivation and inflection; moreover, I assume that both inherent and contextual inflectional number morphology can be used in a language.

1.6 Outline of the thesis

In Chapter 2, I introduce the nature of inflectional and derivational plural marking. I argue that inflectional plural morphology results in the projection of the functional category NumP, discussed in §1.4.1. I adopt Wiltschko's (2008) approach towards recognizing the properties of inflectional plural marking as obligatoriness, agreement, plural marking inside compounds, plural marking inside derivational morphology, form-meaning mismatches (*pluralia tantum*), and bare plurals. I first introduce the idea that the distribution of plural marking in English has inflectional properties in spite of having derivational residues (Wiltschko, 2008). I also review an analysis of plural marking in Halkomelem²¹ as being derivational (Wiltschko, 2008) and in Ojibwe²² as being generally inflectional despite having inherent uses (Mathieu, 2009). Finally, I analyze Persian plural marking, adopting the same approach, and argue that Persian plural marking generally bears the properties of inflectional plural marking, even though it also has some derivational characteristics. I further argue that inflectional plural marking in Persian results in NumP projection. In addition, while showing some derivational properties, I argue

²¹ Halkomelem, which is spoken in British Columbia around Vancouver, is a language of Central Coast Salish.

²² Ojibwe, which is spoken in some parts of the United States and Canada, is an Algonquian language.

that the derivational plural marking in Persian has a modificational role and adjoins nominal roots as a root modifier.

In Chapter 3, I investigate the existence of a grammaticized mass/count distinction, following Borer (2005) and Wiltschko (2007), and explore its relevance to the NumP projection in Persian. I begin by presenting Borer's and Wiltschko's assumptions that if the functional category Num projects in a language, either grammatical number or grammatical classifiers occupy the head of the functional category, as in English-like or in Chinese-like languages, respectively. If grammatical number or classifiers are present in a language, there is a grammaticized mass/count distinction in the language. I further review plural marking in English, Chinese, and Halkomelem (Wiltschko, 2007) as well as in Ojibwe (Mathieu, 2007). Plural marking in English and Ojibwe occupies the head of NumP while classifiers as grammatical number in Chinese occupy the head of NumP, resulting in a grammaticized mass/count distinction in these languages. Conversely, plural marking in Halkomelem is modificational; hence, there is no mass/count distinction in that language. I present evidence of Persian plural marking and argue that number marking in Persian occupies the NumP head, which results in a grammaticized mass/count distinction in Persian. Nevertheless, some Persian data provide empirical evidence of underspecification of mass/count value and pluralisation of mass nouns; as a result, I argue for the modificational role of plural marking adjoining nominal roots.

In Chapter 4, following Borer (2005) that plural marking and classifiers can be in complementary distribution, I further discuss the role of classifiers in Persian in

connection with the discussion of the preceding chapter that classifiers occupy the head of NumP in Persian. I begin by describing the structure of an indefinite noun phrase having a [Card + (CL) + N] combination in Persian and arguing for the co-occurrence restriction of plural marking and classifiers. I further argue that classifiers are optional, and even if a classifier is absent, plural marking cannot occur in this nominal combination because the head of NumP in this structure is either occupied by a full classifier or by an empty classifier. I further show that in a definite noun phrase having a [Card + CL + N + (PL)] combination, a classifier and optional plural marking can co-occur. I argue that the occurrence of plural marking in this structure is not the result of merging as a syntactic category occupying the NumP head; rather, I argue that the plural marker adjoins nominal roots while functioning as a root modifier.

In Chapter 5, I present an analysis of bare singulars/plurals in Persian in predicative or argument position and explain their relationship to the projection of NumP. I first explain the distribution of singulars/plurals in Persian. With reference to NumP, I discuss the two morpho-syntactic parameters, the Free Agr parameter and the empty determiner parameter, introduced by Schmitt and Munn (2000) and explain that in Brazilian Portuguese these two parameters that allow bare singulars in argument positions. I show that, in Persian, the Free Agr parameter allows the presence of bare singulars in predicative positions. Furthermore, I explain how the non-projection of NumP in some argument positions in Persian results in the occurrence of bare singulars. Following Schmitt and Munn (2000), I further explain how the empty determiner parameter in Brazilian Portuguese allows definite bare

singulars that have empty Ds. I also present Ghomeshi's (2008) claim that definite bare singulars/plurals having D^0 -heads belong to DP categories. Ghomeshi's discussion of DPs with D^0 -heads in Persian is in line with the discussion of the empty determiner parameter.

Moreover, I argue that in object position in Persian, definite singulars or plurals that are *ra*-marked can have different readings. I introduce the definite expletive determiner found in French (Vergnaud & Zubizarreta, 1992) and argue that an expletive definite determiner induces a type reading, while a definite determiner has a token interpretation. Following the discussion of the expletive definite determiner in French, I show that *ra*-marked direct objects in Persian can induce either a type or token reading. I argue that if an empty definite determiner accompanying a *ra*-marked object in Persian is expletive, a type reading is induced; however, a token interpretation is received if there is merely an empty definite determiner.

In Chapter 6, I present the summary and conclusions of the thesis.

Chapter 2: Distribution of plural morphology

2.1 Introduction

This chapter focuses on providing the answer to the question of whether the nature of the plural marker in Persian is inflectional or derivational (see Kahnemuyipour, 2002, 2004).

Wiltschko (2008) argues that the properties of inflectional morphology can be viewed as leading to the projection of a syntactic category, namely a functional category. As discussed in §1.5.1, inflectional plural marking, as a syntactic category, merges as the head of the functional category NumP, resulting in number marking. On the other hand, derivational plural marking, as a non-inflectional syntactic category, functions as an adjunct adjoining a nominal root and modifying it. Considering the characteristics of plural marking in Persian, I show how it has the properties of both inflectional and derivational plural marking; however, the inflectional properties are revealed to outweigh the derivational properties. Since Persian plural marking is both inflectional and derivational, I argue that it functions independently from Wiltschko's (2007, 2008) parameter setting, which considers number either as a functional head or as a modifier. I strongly disagree on having either type of plural marking in Persian. I show how Persian plural marking not only merges as a head but also adjoins as a root modifier, which results in having both inflectional and derivational plural marking in Persian. Following Booij (1993, 1995), I argue that Persian plural marking, like number marking in Ojibwe (Mathieu, 2009), is inflectional in spite of having some inherent residues. Although

the inflectional properties of plural marking in Persian indicate that number is the head of a functional category and leads to the projection of NumP, the derivational properties show the modificational role of plural marking when the plural marker adjoins nominal roots.

2.2 Inflectional vs. derivational plural morphology

Wiltschko (2008) highlights some of the characteristics of inflectional plural marking as obligatoriness, agreement, form-meaning mismatches (*pluralia tantum*), and bare plurals, and some of the characteristics of derivational plural marking as plural marking inside compounds and plural marking inside derivational morphology. This chapter presents the distribution of plural marking in English as inflectional while having derivational residues, in Halkomelem as derivational, in Ojibwe as generally inflectional while having inherent uses, and in Persian as inflectional while showing some derivational uses.

In the next section, I review Wiltschko's (2008) diagnostics for determining whether plural marking is inflectional or derivational. Using the same diagnostics, I analyze the nature of plural marking in Persian.

2.2.1 Obligatoriness

According to Wiltschko (2008), in English, which has inflectional plural marking, when a noun is combined with a cardinal greater than one, the noun must be plural, as in (1):

(1) a. the three boy-s

b. *the three boy

(Wiltschko, 2008:642)

However, in Halkomelem, when a noun follows a cardinal that is greater than one, the use of the plural marker is optional. Therefore, either a singular noun or a plural noun is acceptable, as in (2) and (3):

(2) a. te Ihíxw swíweles

DET three boy

‘the three boys’

b. te Ihíxw swóweles

DET three boy.PL

‘the three boys’

(Wiltschko, 2008:642)

(3) a. qex te s-th’ím

many DET NOM-berry

‘many berries’

b. qex te s-**th**’eth’ím

many DET NOM-berry.PL

‘many berries’

(Wiltschko, 2008:642)

Wiltschko (2008) also points out that plurality marking in some languages is based on a person-hierarchy, as Corbett (2000:55) argues. That is, only human or animate nouns can be plural. In Halkomelem, however, human nouns or inanimate nouns, as shown in (2) and (3), have optional plural marking. That the unmarked nouns in (2) and (3) are compatible with their plural interpretations is the characteristics of *general number* (Corbett, 2000).

However, in Ojibwe, as in English, the plural marker is obligatory when a cardinal greater than one is used with an animate noun, as in (4), or with an inanimate noun, as in (5):

(4) a. niizh gwiizens-**ag**

two boy-PL(AN)

‘two boys’

b. *niizh gwiizens

two boy

‘two boys’

(Mathieu, 2009:6)

(5) a. niibina miin-**an**

many berries-PL(IN)

‘many berries’

b. *niibina miin

many berries

‘many berries’

(Mathieu, 2009:6)

Mathieu (2009) argues that Ojibwe and English are similar in that the unmarked noun *boy* in (1b) in English and the unmarked noun *gwiizens* in (4b) in Ojibwe are not compatible with plural interpretations. In these languages, in order to have a plural interpretation, plural marking is necessary. This demonstrates that these languages have a typical characteristic of inflectional plural marking, namely, obligatoriness.

In Persian, when a cardinal greater than one is used, the noun it modifies must be unmarked, as in (6):

(6) a. se pesær

three boy

‘three boys’

b. *se pesær-ha²³

three boy-PL

²³ The co-occurrence of the classifier *ta* and the plural marker is possible in colloquial Persian, but with definite reading, which will be discussed in detail in Chapter 4:

(i) se ta pesær-ha
three CL boy-PL
‘the three boys’

In other words, an unmarked noun in Persian accompanying a cardinal greater than one obligatorily has a plural interpretation. This is unlike plural marking in Halkomelem having optional plural marking with cardinals greater than one, which is not the characteristic of inflectional plural marking. Moreover, the obligatoriness of plural marking in English and Ojibwe on nouns accompanying a cardinal greater than one does not resemble plural marking in Persian either.

However, the fact that plural marking cannot occur with cardinals greater than one in Persian must not be considered as a reason that number marking is not obligatory in Persian. Rather, the obligatoriness of Persian number marking in these constructions can be viewed as the presence of a cardinal with a classifier. Persian is a classifier language, as are Chinese-like languages, which require classifiers for number marking, as shown in (7) and (8). The presence of classifiers in Chinese languages can be compared to the case of Persian, as shown in (9):

- (7) a. san ben shu (Mandarin)
 b. saN bun zhu (Southern Min)
 c. saam bun syu (Cantonese)

three CL^{volume}book

(Cheng & Sybesma, 2005:276)

- (8) a. yi *(ben) shu (Mandarin)
 b. i *(paŋ) si (Wenzhou)
 c. jit *(bun) zhu (Southern Min)

d. yat *(bun) syu (Cantonese)
one CL^{volume} book

(Cheng & Sybesma, 2005:273)

(9) a. do ta sib
two CL apple
'two apples'

b. se ta medad
three CL pencil
'three pencils'

c. pænʃ qatte qali
five CL^{piece} rug
'five rugs'

However, the difference between Chinese languages and Persian can be seen in the obligatory presence of classifiers in Chinese languages and the optional presence of classifiers in Persian, as in (10). The fact that Persian classifiers are optional does not imply that obligatoriness does not apply to Persian number marking. Rather, the use of full classifiers or empty classifiers with cardinals is obligatory in Persian, as in (11). This is discussed in detail in Chapter 4²⁴:

²⁴ In the discussion of classifiers and the plural marker in Chapter 4, I argue that they are in complementary distribution because either of them can occupy the head of NumP in Persian.

(10) a. do (ta) sib

two (CL) apple

‘two apples’

b. se (ta) medad

three (CL) pencil

‘three pencils’

c. pænʃ (qatte) qali

five (CL^{piece}) rug

‘five rugs’

(11) a. do (Ø^{CL}) sib

two (Ø^{CL}) apple

‘two apples’

b. se (Ø^{CL}) medad

three (Ø^{CL}) pencil

‘three pencils’

c. pænʃ (Ø^{CL}) qali

five (Ø^{CL}) rug

‘five rugs’

In sum, the obligatoriness characteristic of Persian number marking is realized to be the presence of full classifiers or empty classifiers, while in English and Ojibwe this characteristic is realized as the presence of plural marking, which is different from the optional use of plural marking in Halkomelem.

2.2.2 Agreement

Agreement is another characteristic of inflectional plural marking. In English, there must be agreement inside the DP, which results either in the plurality or singularity both of nouns and of other elements that can be plural in nominal phrases, as in (12a), where the demonstrative and the noun are both plural, or as in (12d), where the singular demonstrative and noun can co-occur. Number agreement inside the DP goes along with the obligatoriness of plural marking. In (12b), the demonstrative is not marked for plural, which results in the ungrammaticality of the structure. In (12c), on the other hand, the use of the plural demonstrative is incompatible with the singular noun:

(12) a. **These** boys can sing.

b. *This boys can sing.

c. ***These** boy can sing.

d. This boy can sing.

(Wiltschko, 2008:643)

While there is obligatoriness of number agreement in English, in Halkomelem number agreement is optional. A plural noun in Halkomelem can co-occur both

with the plural determiner *ye*, as in (13a), or with the unmarked determiner *te*, as in (13b). An unmarked noun can also co-occur with the plural determiner, as in (13c), or with the unmarked determiner, as in (13d):

(13) a. t'ílém **ye** s-í:wí:qe b. t'ílém **te** s-í:wí:qe
 sing **DET.PL** man.PL sing **DET** man.PL
 ‘The men are singing.’ ‘The men are singing.’

c. t'ílém **ye** swíyeqe d. t'ílém **te** swíyeqe
 sing **DET.PL** man sing **DET** man
 ‘The men are singing.’ ‘The man is singing.’

(Wiltschko, 2008:643)

Wiltschko (2008) proposes that there is no number agreement in Halkomelem because there is no projection of a functional head. Therefore, number is not involved in subject-verb agreement in Halkomelem, but person is. In (14), both the singular and plural subjects have the same subject agreement marker, (-*es*):

(14) a. máy-t-**es** ye sí:wí:qe ye slheláli
 help-TRANS-3S **DET.PL** man.PL **DET.PL** woman.PL
 ‘The men are helping the women.’

b. máy-t-es te swiyeqe ye slheláli
help-TRANS-3S DET man DET.PL woman.PL

‘The man is helping the women.’

(Wiltschko, 2008:654-655)

In Ojibwe, there is number agreement between the nouns and the demonstrative for both animate and inanimate nouns, as in (15) and (16), respectively. However, (15c) and (16c) are ungrammatical because there is no agreement between the noun and the plural demonstrative in either structure:

(15) a. maaba gwinzens

this.AN boy

‘this boy’

b. maamig gwinzens-**ag**

these.AN boy-PL

‘these boys’

c. *maamig gwinzens

these.AN boy

‘these boys’

(Mathieu, 2009:7)

(16) a. maanda baagan

this.IN nut

‘this nut’

b. maamin baagan-**an**

these.IN nut-PL

‘these nuts’

c. *maamin baagan

these.IN nut

‘these nuts’

(Mathieu, 2009:8)

While there is no number agreement in Halkomelem, as shown in (14), in Ojibwe both person and number are involved in the subject-verb agreement. The 3rd person singular suffix *-ig* in (17a) agrees with the 3rd person singular subject. Also, in (17b), the 3rd person plural subject agrees with the 3rd person plural suffix *-oog*:

(17) a. nene n-gii-waabm-**ig**

man-3SG 1SG-PAST-see-3SG

‘(A) man saw me.’

b. nenwag n-gii-waabm-**igoog**.

man-3PL 1SG-PAST-see-3PL

‘Men saw me.’

(Mathieu, 2009:8)

In Persian, if a noun is singular, the demonstrative inside the DP is singular, as in (18), which has *in* ‘this’ as a singular demonstrative; however, there is no agreement between unmarked demonstratives and plural nouns, as in (19). Rather, a plural-marked noun is compatible with a singular demonstrative, as in (19), while a plural-marked noun is not compatible with a plural demonstrative, as in (20):

(18) *in doxtær*

this girl

‘this girl’

(19) *in doxtær-ha*

this girl-PL

‘these girls’

(20) **in-ha doxtær-ha*

this-PL girl-PL

Example (21) shows that agreement is realized as a full or empty classifier. When a noun is preceded by a quantifier, there is number agreement between the quantifier and the full or empty classifier:

(21) a. *čænd (ta) medad*

some (CL) pencil

‘some pencils’

b. čænd (\emptyset^{CL}) medad

some (\emptyset^{CL}) pencil

‘some pencils’

There is also agreement between singular determiners and unmarked nouns, as in (22) and (23); moreover, agreement exists between plural determiners and plural-marked nouns, as in (24), (25), (26), and (27):

(22) hær bačče

every child

‘every child’

(23) hič-kæs

no-person

‘no one’

(24) ba?zi danešju-ha

some student-PL

‘some students’

(25) hame-ye pesær-ha

all-EZ boy-PL

‘all boys’

(26) bæčče-ha-ye bištær

child-PL-EZ more

‘more children’

(27) bæčče-ha-ye kæmtær

child-PL-ye fewer

‘fewer children’

When subjects are animate in Persian, there is subject-verb agreement, as in (28) and (29). In the case of animate subjects, both number and person are involved in subject-verb agreement:

(28) a. u amæd.

he/she come.PAST-3SG

‘He/She came.’

b. anha amæd-ænd.

they come.PAST-3PL

‘They came.’

(29) a. madær be xærid ræft.

mother to shopping go.PAST-3SG

‘The mother went shopping.’

b. madær-ha be xærid ræft-ænd.
mother-PL to shopping go.PAST-3PL
'The mothers went shopping.'

Nevertheless, when subjects are inanimate in Persian, subject-verb agreement is optional. Ghaniabadi (2010) uses Wiltschko's (2008) diagnostics to distinguish inflectional plural marking from modificational²⁵ plural marking. He further argues that in Persian inanimate plural subjects do not agree with verbs in number, as shown in (30a). In spite of his argument, the grammaticality of (30b) shows that inanimate nouns involve both number and person agreement, although number agreement is optional:

(30) a. bærg-a rixt.
leaf-PL fell.3SG
'The leaves fell.'

(Ghaniabadi, 2010:142)

b. bærg-a rixt-ænd.
leaf-PL fall.PAST-3PL
'The leaves fell.'

²⁵ Ghaniabadi (2010), however, argues that this evidence cannot support the idea that plural marking in Persian is modificational. Rather, following Sedighi (2005), he assumes that agenthood rather than subjecthood triggers verbal agreement; hence, there is no agreement between Persian inanimate plural subjects and verbs because they are not agents.

The optionality of number agreement is illustrated in (31a) and (31b):

- (31) a. gol-ha xošk=šod-ænd.
flower-PL dry=become.PAST-3PL
'The flowers dried.'

- b. gol-ha xošk=šod.
flower-PL dry=become.PAST-3SG
'The flowers dried.'

In spite of reports in Persian grammar books on the use of non-agreeing verbs when plural inanimate subjects are used, Sedighi (2007) also argues that speakers of Persian select either a singular or plural verb when using an inanimate subject, as in (32):

- (32) a. ghætre-ha-ye baran be zæmin chekid-Ø.
drop-pl-_{ezafe} rain to ground dropped-3sg
Raindrops fell down on the ground.

- b. ghætre-ha-ye baran be zæmin chekid-ænd.
drop-pl-_{ezafe} rain to ground dropped-3pl
Raindrops fell down on the ground.

(Sedighi, 2007:40)

Sedighi (2007) further proposes that both animate and inanimate subjects in Persian can take agreement. However, based on the rule in (33), Number is optionally impoverished in the context of [-Ani]; therefore, the verb is changed to the default morphology of the third person singular:

(33) Persian Impoverishment rule

$[N] \rightarrow \emptyset / [-Ani]$

(Sedighi, 2007:45)

Sedighi (2007) introduces another type of Persian verb, known as the “psychological verb” and used in “psychological constructions”, as in (34). The verb in (34) does not agree with the experiencer, *ma*, in subject position. Such constructions are also termed “Impersonal” in the literature.

(34) **ma** æz u xoš-eman amæd- \emptyset .

we from her/his pleasure-1pl came-**3sg**

We liked her/him (She/he appealed to us).

(Sedighi, 2007:7)

These verbs, which always appear in the third person singular form, give the impression that there is no agreement in psychological constructions. However, in (34), the clitic pronoun *-eman*, the non-verbal constituent of the verb, agrees in

number and person with the subject. Additional examples of psychological verbs are given in (35) and (36):

(35) (mæn) æz ræng-e abi xoš-æm=mi-a-yæd.

(I) from color-EZ blue like-1SG=DUR-come.PRES-3SG

‘I like the color blue.’

(36) (anha) særd-ešan=šod.

(They) cold-3PL=become.PAST-3SG

‘They got cold.’

In (35), the number and person agreement is between the subject *mæn* ‘I’ and the clitic pronoun *-æm*. Also, in (36), the agreement is between the subject *anha* ‘they’ and the clitic pronoun *-ešan*. The optional use of the subjects in (35) and (36) suggests that the agreement is required even in the case of null subjects.

In sum, in English, which has inflectional plural marking, there is agreement between a noun and a demonstrative inside the DP. In Ojibwe, another language with inflectional plural marking, there is obligatory agreement between demonstratives and animate or inanimate nouns. Moreover, obligatory number and person agreement exists between subjects and verbs. However, in Halkomelem, a language having derivational plural marking, number agreement is optional, and only person (but not number) is involved in subject-verb agreement. In Persian, however, the agreement property appears to function differently. There is no

agreement between unmarked demonstratives and plural nouns, while there is agreement between plural quantifiers and full or empty classifiers. Furthermore, agreement takes place between singular determiners and unmarked nouns, and between plural determiners and plural-marked nouns. In the case of subject-verb agreement, both number and person are involved when subjects are animate; however, when subjects are inanimate nouns, there is person agreement, but number agreement is optional. In general, the agreement characteristics in Persian, including the subject-verb agreement, show that Persian plural marking is inflectional, but there are derivational residues.

2.2.3 Plural marking inside compounds

Another characteristic of inflectional plural marking in English is that it generally cannot occur inside compounds. For instance, as seen in (37a), the word *tooth* is not marked for plural although the tool is generally used for all teeth of an individual. This can also be observed in (37b) where the word *child* does not have plural marking, even though in child-care, there is usually more than one child:

- (37) a. tooth-brush *teeth-brush
 b. child-care *children-care

(Wiltschko, 2008:644)

Additional examples that plural marking is not allowed inside compounds in English are shown in (38):

Therefore, plural marking inside compounds, as shown in (39) and (40), is possible in Halkomelem, which indicates that plural marking is not inflectional in this language.

In Ojibwe, however, compounds are head last, and plural marking cannot occur inside them, as seen in (41) and (42):

(41) a. aamoo-ziinzibaakwad

bee-sugar

‘honey’

b. *aamoo-gziinzibaakwad

bee-PL-sugar

(Mathieu, 2009:9)

(42) a. ishkode-daaban

fire-car

‘train’

b. *ishkode-n-daaban

fire-PL-car

(Mathieu, 2009:9)

Pluralisation of the whole compound when the nominal is plural is shown in (43). This property of Ojibwe plural marking is the same as that of English but different from that of Halkomelem.

(43) ishkode-daaban-an

fire-car-PL

‘trains’

(Mathieu, 2009:9)

In Persian, plural marking inside compounds is the same as in English and Ojibwe, namely, there is no plural marking inside compounds, as in (44) and (45), where the merging of two free morphemes makes such compounds:

(44) a. sərbaz-xane

soldier-house

‘barracks’

b. *sərbaz-ha-xane

soldier-PL-house

(45) a. ketab-xane

book-house

‘library’

b. *ketab-ha-xane

book-PL-house

In Persian, the pluralisation of the last nominal makes the whole compound plural, as in (46) and (47):

(46) mehman-særa-ha

guest-house-PL

‘inns’

(47) čay-xane-ha

tea-house-PL

‘tea houses’

In sum, in English and Ojibwe plural marking inside compounds is not allowed; therefore, these languages have inflectional plural marking. Unlike English and Ojibwe, Halkomelem, having derivational plural marking, allows plural marking inside compounds. Persian is shown to have inflectional plural marking, as it does not allow plural marking inside compounds.

2.2.4 Plural marking inside derivational morphology

Another characteristic of inflectional plural morphology is its distribution in connection with derivational morphology. Plural marking as an inflectional

category in English does not occur inside derivational morphology, as seen in (48).

In English, the merging of a root nominal with a derivational affix must occur before the merging of an inflectional affix such as the plural marker.

- (48) a. dog-ish *dog-s-ish
 b. mother-ese *mother-s-ese
 c. brother-hood *brother-s-hood
 d. tattoo-ist *tattoo-s-ist

(Wiltschko, 2008:645)

In Halkomelem, however, plural marking does happen inside derivational morphology²⁶. Plural reduplication disregards the prefix *s-*, which is a nominalizer, as seen in (49):

- (49) a. p'eq' s-p'eq' s-**p'eq'** p'eq' (*sp'eq'sp'eq')
 white NOM-white NOM-white.PL
 'white' 'white spot on skin' 'white spots on skin'

²⁶ Stump (1998) shows that in Breton the noun *bagig* 'little boat', which is diminutive, has the plural form as *bagoùigoù*. In this plural word, one plural suffix *-où* occurs before *-ig*, which is the diminutive suffix. The other plural suffix occurs after the diminutive suffix.

Perlmutter (1988) also shows that in Yiddish there are several cases where plural inflection occurs inside the diminutive morphology, as in the following examples. In (i), the plural suffix is *-er* (including the ablaut in the word *derner*), and the diminutives occur after the plural suffixes. The examples in (ii) are loan words from Hebrew/Aramaic. The plural suffix *-im* in (ii) occurs before the diminutive plural *-lex*.

- (i) Sg pl Dim pl
 child *kind* *kinder* *kinderlex*
 thorn *dorn* *derner* *dernerlex*
 (ii) Sg pl Dim pl
 body *guf* *gufim* *gufimlex*
 pupil *talmid* *talmidim* *talmidimlex*

b. th'ekw'	s-th'eth'ikw'	s- th'ekw' th'ékw' (*sth'ekw'sth'ekw')
be sore	NOM-CONT.sore	NOM-sore.PL
'be sore'	'sore'	'lots of sores'

(Galloway, 1993:379)

In Ojibwe, unlike in Halkomelem, plural marking cannot occur between a root and a derivational morpheme. Ojibwe has a series of nominalizers such as *-gan*, *-win*, and *-w*. Plural marking never occurs between these nominalizers, which are considered to be derivational in nature, and the roots, as shown in (50b) and (51b):

(50) a. bkwenzh-gan-ag

bread-NOM-PL

'breads'

b. *bkwenzh-ag-gan

bread-PL-NOM

(Mathieu, 2009:10)

(51) a. wazas-win-an

nest-NOM-PL

'nests'

b. *wazas-an-win

nest-PL-NOM

(Mathieu, 2009:10)

In Persian, plural marking is not possible inside derivational morphology if the plural marker is *-ha*, as in (52) and (53). However, Kahnemuyipour (2000, 2004) argues that it is possible with the plural marker *-at*, as in (54) and (55)²⁷:

(52) a. xub-i-ha

good-NOM-PL

‘goodness-PL’

b. *xub-ha-i

good-PL-NOM

(53) a. orupa-yi-ha

Europe-ADJ-PL

‘Europeans’

²⁷ The original examples by Kahnemuyipour (2000) are as follows; however, I have changed the way they were presented in order to have conformity with the other examples:

(1) ehsâs → ehsâs-ât → ehsâsât-i
“emotion” “emotions” “emotional (for person)”

(ii) xiyâl → xiyâl-ât → xiyâlât-i
“imagination” “imagnations” “day-dreamer”

(Kahnemuyipour, 2000:7)

b. *orupa-ha-yi

Europe-PL-ADJ

(54) ehsas-at-i

emotion-PL-ADJ

‘emotional (for person)’

(55) xiyal-at-i

imagination-PL-ADJ

‘day-dreamer’

Kahnemuyipour (2000) also argue that plural marking inside derivational morphology is possible in Persian if the plural marker is *-an*²⁸, as in (56).

(56) a. do-sa:l-a:n-e

two-year-PL-ADJ

‘biennial’

b. bačče-ga:n-e

child-PL-ADJ

²⁸ The following examples are taken from Kahnemuyipour (2000):

(i) a mard → mar-ân → mard-ân-e
‘man’ “men” “of (related to) men”
b. jâhel → jâhel-ân → jâhel-ân-e
“ignorant (person)” “ignorant people” of (related to) ignorant

(Kahnemuyipour, 2000:6)

‘childlike/of (related to) children’

c. zæn-an-e

woman-PL-ADJ

‘womanly/of (related to) women’

According to Kahnemuyipour (2004), that inflectional morphology can appear inside derivational morphology in Persian is considered as evidence against ‘split morphology hypothesis’ (Wasow, 1977; Beard, 1998; Stump, 1998).

In sum, plural marking as inflectional morphology cannot appear inside derivational morphology in English and Ojibwe, unlike in Halkomelem. Analysis of Persian reveals that if the plural marker is *-ha*, it does not permit plural marking inside derivational morphology; however, exceptions of plural marking inside derivational morphology can be found with the plural markers *-at* and *-an*. Thus, Persian displays characteristics of both inflectional and derivational plural morphology.

2.2.5 Form-meaning mismatches (*pluralia tantum*)

Wiltschko (2008) proposes that form-meaning mismatches (*pluralia tantum*) can exist in a language if there is inflectional plural marking, but not if there is modificational plural marking. In English, which has a syntactic head for plural marking, there are grammatically plural words whose interpretations are not necessarily plural, as in (57):

(57) barracks, headquarters, pliers, shorts, clothes, jeans, premises, spectacles,
contents, manners, pajamas, spirits, cross-roads, means, scissors, trousers,
goods, outskirts, savings, valuables

(Wiltschko, 2008:662)

Such nouns have only one form; therefore, there can be ambiguity between a singular or plural interpretation in structures such as (58), which is ambiguous between having a pair of jeans or several pairs of jeans:

(58) These jeans are tight.

(Wiltschko, 2008:662)

However, if a classifier such as *pair* is used in such a structure, it can disambiguate the DP, as in (59):

(59) a. This pair of jeans is tight.

b. These pairs of jeans are tight.

(Wiltschko, 2008:662)

Wiltschko (2008) argues that Halkomelem does not have any *pluralia tantum* (Galloway, 1993). Since number as a grammatical category is absent, and since plural marking has a modificational role, there are no mismatches between form and meaning; therefore, *pluralia tantum* is absent in Halkomelem.

Conversely, in Ojibwe, as in English, there are a few inherently plural nouns, as in (60):

(60) a. *biiwekdamaagnan* ‘wood shaving’ (W)

b. *bootsan* ‘boots’ (from English boots, Odawa)

c. *e-baásgobjigemgakin* ‘spring-tooth harrows’, a farm implement.

(Valentine, 2001: 182)

In Persian, however, there is no *pluralia tantum*. There are some borrowed nouns from Arabic marked plural with the Arabic plural marker *-at*, but they do not behave as plural because: (i) they show no subject-verb agreement, as in (61); (ii) they can also occur with classifiers and plurals, as in (62), which is not possible with plural marking in Persian; (iii) they occur inside derivational suffixes, as in (63):

(61) a. *tæzahor-at-e* *diruz* *xub* *bud*.

demonstration-PL-EZ yesterday good be-PAST.3SG

‘Yesterday’s demonstration was good.’

b. **tæzahor-at-e* *diruz* *xub* *bud-æn*.

demonstration-PL-EZ yesterday good be-PAST.3PL

(62) *se* *ta* *tæzahor-at*

three CL demonstration-PL

‘three demonstrations’

- (63) mobarezat-e entexab-at-i
campaign-EZ election-PL-ADJ
'election campaigns'

In sum, English and Ojibwe, which have inflectional plural marking, have *pluralia tantum*; conversely, Halkomelem, which has modificational plural marking, has no *pluralia tantum*. In Persian, as in Halkomele, there is no instances of *pluralia tantum*.

2.2.6 Bare plurals

In English, a pluralized noun can be used without a determiner, as a bare plural functioning as a NumP, in an argument position, as in (64):

- (64) a. I saw bears.
b. Bears saw me.

(Mathieu, 2009:11)

Wiltschko (2008), following Déchaine and Wiltschko (2002), argues that if a functional structure is present, a nominal predicate can become an argument. The fact that there are bare plurals in English argument positions reveals that the functional structure (#P) is present in this language. In other words, the presence of a number category as a functional category in English is the reason that bare plurals

can be used in argument positions. There is no licensing of nouns as arguments if such a functional category is not present.

However, in Halkomelem, the presence of the plural marker does not result in the projection of the functional category NumP, namely, there is no change of the syntactic category if a noun is plural. Consequently, in Halkomelem, there are no bare plurals. Rather, determiners must precede nouns in argument positions, as in (65):

(65) a. tsel kw'ets-l-exw *(te) {swíyeqe/sí:wí:qe}

1SG.S see-TRANS-3O DET man/man.PL

'I saw the man/the men.'/'I saw a man/men.'

b. t'ít'elem *(te) {slháli/slhelhláli}

singing DET woman/woman.PL

'The woman/women is/are singing.'/'A woman/women is/are singing.'

(Wiltschko, 2008:668)

In Ojibwe, as in English, bare plurals can appear in both subject and object position, as in (66):

(66) a. n-gii-waabmag nenwag.

1SG-PAST-see-3PL men-3PL

'I saw men.'

b. *nenwag n-gii-waabm-igoog.*
men-3PL 1SG-PAST-see-3PL
'Men saw me.'

(Mathieu, 2009:11)

Persian, which does not have definite²⁹ or indefinite³⁰ determiners, allows bare plurals in argument positions, with different readings. In subject position, they can have an indefinite or definite reading depending on the context, as in the bare plurals *pesær-ha* 'boys' and *doxtar-ha* 'girls' in (67) and (68), respectively:

(67) *pesær-ha xub kar=mi-kon-ænd.*

boy-PL well work=DUR-do.PRES-3PL
'The boys/Boys work well.'

(68) *doxtar-ha xub dars=mixan-ænd.*

girl-PL well lesson=read-DUR-do.PRES-3PL
'The girls/Girls study well.'

²⁹ In Persian colloquial speech, there is a stressed suffix marker, *-e* or *-æ*, marking definiteness (Ghomeshi, 2003).

³⁰ Although there is no indefinite determiner in Persian, indefiniteness is induced by means of the indefinite enclitic *-i*, heading a QP (Ghomeshi, 2003).

However, some bare plurals in subject position, as *pesær-ha* ‘boys’ and *madær-ha* ‘mothers’ in (69) and (70), respectively, can only receive definite readings, which is forced by the context and not by the noun phrase itself:

(69) *pesær-ha* *zud* *be* *mædrese* *raft-ænd*.

boy-PL early to school go.PAST-3PL

‘The boys went to school early.’

(70) *madær-ha* *dar* *xane* *mand-ænd*.

mother-PL at home stay.PAST-3PL

‘The mothers stayed at home.’

As discussed in Chapter 1, the use of bare plurals in object positions is very restricted. These constructions are quite marked while carrying a particular emotional connotation of surprise or amazement, as in (71) and (72):

(71) *mæn* *šæhr-ha* *did-æm*³¹.

I city-PL see.PAST-1SG

‘I saw all sorts of cities.’

³¹ The bare plural in (71) has the following connotation:
‘You can’t imagine how many sorts of cities I saw.’

(72) ma ketab-ha xær-idim³².

we book-PL buy.PAST-3PL

‘We bought all sorts of books.’

In order to induce a definite interpretation, bare plurals in object positions³³ in Persian must be followed by the object marker *ra*, as in (73) and (74):

(73) mæn šæhr-ha-ra did-æm.

I city-PL-OM see.PAST-1SG

‘I saw the cities.’

(74) ma ketab-ha-ra xær-idæm.

we book-PL-OM buy.PAST-1PL

‘I bought the books.’

In sum, bare plurals in English and Ojibwe can occur in subject or object position, which shows that NumP is projected in argument positions. Nevertheless, in Halkomelem bare plurals do not occur, which reveals the modificational property of plural marking as derivational morphology. In Persian, however, bare plurals³⁴ behave differently in subject and object positions. The marked interpretation of

³² The bare plural in (72) has the following connotation:
‘You can’t imagine how many sorts of books we bought.’

³³ As discussed in Chapter 1, the difference between marked bare plurals and definite bare plurals in object positions is beyond definiteness because they are asymmetrical. The former are quite marked and the latter are definite.

³⁴ See Chapter 5 for a detailed analysis of bare plurals in Persian.

bare plurals in object positions shows the modificational property of Persian plural marking. However, the other cases of bare plurals in subject or object positions reveal that Persian plural marking is inflectional. Therefore, both inflectional and derivational plural marking are possible.

2.3 Summary

The plural marking characteristics of English, Halkomelem, Ojibwe, and Persian are summarized in the following table:

	English	Halkomelem	Ojibwe	Persian
Obligatory number marking	yes	no	yes	yes
Obligatory agreement	yes	no	yes	yes/no
Plural inside compounds	no	yes	no	no
Plural inside derivational morphology	no	yes	no	yes/no
Pluralia tantum	yes	no	yes	no
Bare plurals	yes	no	yes	yes/no

In sum, Persian plural marking appears to have some similar and some different characteristics from those of English, Halkomelem, and Ojibwe, considering the characteristics of the inflectional plural marking (obligatoriness, agreement, form-meaning mismatches (*pluralia tantum*), and bare plurals) and characteristics of derivational plural marking (plural marking inside compounds and plural marking inside derivational morphology). In English, plural marking is

inflectional; as a result, the functional category NumP projects. However, in Halkomelem, which has derivational plural morphology, plural marking is modificational. Plural marking in Ojibwe is inflectional, and the functional category number projects although plural marking has some inherent properties. In contrast, plural marking diagnostics show that Persian plural marking has characteristics of both inflectional and derivational plural marking. In fact, the inflectional characteristics of plural marking appear to outweigh the derivational characteristics, namely, most of the diagnostic tests for characteristics of Persian plural marking reveal that Persian plural marking is inflectional. Obligatory number marking of (full or empty) classifiers, subject-verb agreement of animate subjects and optionality agreement of inanimate subjects, impossibility of plural marking inside compounds, impossibility of plural marking inside derivation morphology with the default plural marker *-ha*, and most cases of bare plural reveal that Persian plural morphology is mainly inflectional; however, it has some derivational residues. In fact, the inflection uses of Persian plural morphology reflect the inflectional characteristics while the derivational uses show the derivational properties.

Hence, plural marking in Persian functions independently from Wiltschko's (2007, 2008) parameter setting, according to which number is either a modifier or a functional head. Rather, Persian plural marking is not only inflectional, but also inherent, following Booij (1993, 1995). Taking the inflectional characteristics into consideration, it can be concluded that the functional category Number Phrase (NumP) projects in Persian. That Persian plural marking is revealed to have some

characteristics of derivational plural marking indicates that the plural marker in Persian adjoins nominal roots when having a modificational role. This can be illustrated by empirical evidence, as discussed in Chapter 3.

Chapter 3: Mass/count distinction in Persian

3.1 Introduction

This chapter explores the existence of a grammaticized mass/count distinction and its relevance to plural marking or classifiers in Persian. It is interesting to investigate whether there is such a relation because there are controversial claims in the literature with regards to the mass/count distinction and the sources of countability in Persian.

Borer (2005) argued that if the functional category NumP is present in a language, either the plural marker, as in English-like languages, or grammatical classifiers, as in Chinese-like languages occupy its head. Either of these makes nouns individualized and results in the existence of a grammaticized mass/count distinction in the language. Wiltschko (2007) proposes that the non-existence of the functional category Num in Halkomelem leads to the absence of a grammaticized mass/count distinction. She further argues that any kind of noun can be the target of plural marking in Halkomelem, and that the plural marker in that language is attached to the nominal root.

Taking the inflectional properties of Persian plural marking into account, I propose that the functional category NumP projects in Persian. Moreover, I propose that a grammaticized mass/count distinction exists in Persian, with either the plural marker or classifiers occupying the head of NumP and having a role in individualizing nouns. However, I show that mass pluralisation in Persian can induce a ‘large amount of mass’ interpretation; as a result, I propose that when the

plural marker is derivational in Persian, it adjoins nominal roots while modifying them. Furthermore, based on empirical evidence, I propose that when roots are underspecified for mass/count values, there is non-projection of the NumP category.

In the following section, I present the puzzles related to the sources of countability in Persian.

3.2 The puzzles

The concept of mass/count distinction has been discussed in the literature in connection with the properties and sources of countability cross-linguistically. In some languages, such as English, the mass/count distinction is realized at the level of grammatical number. In other words, the plural marker occupies the head of NumP. However, in some other languages, such as Chinese, it is realized at the level of classifiers. For Persian, there is no agreement in the literature on the existence of a mass/count distinction and the role of plural marking or classifiers in realizing a mass/count distinction. Moreover, there is no reference to countability in Persian grammar books since most Persian grammarians believe that a distinction between mass and count nouns does not exist in Persian. Bateni (1976) believes that the non-existence of a mass/count distinction in Persian means that all nouns, except for the subcategory of proper nouns, are count nouns, that is, they can be pluralized³⁵. However, according to Abbassi (2002), “countability is not a constant

³⁵ Abstract nouns in Persian can also be pluralized. Some examples of such words are *huš-ha* ‘intelligence-PL’, *æql-ha* ‘wisdom-PL’, *xubi-ha* ‘goodness-PL’, *bædi-ha* ‘badness-PL’, *tærs-ha* ‘fear-PL’, *næfræt-ha* ‘hatred-PL’, *xæšm-ha* ‘anger-PL’, *iman-ha* ‘faith-PL’, *bæxšæš-ha* ‘forgiveness-PL’, *pærhizkari-ha* ‘abstinence-PL’, and *eræde-ha* ‘will-PL’.

feature of a noun in Farsi³⁶ and is determined by the context in which it is used, e.g. by the quantifiers adjacent to the noun” (p. 3). On the other hand, Ghomeshi (2003) argues that Persian is like Chinese in terms of employing classifiers in order to make nouns countable. However, Ghomeshi claims that the category NumP is not present in Persian, but classifiers in this language, as classifiers in Chinese, result in a mass/count distinction. Therefore, there is no agreement in the literature on the sources of countability in Persian.

In order to investigate the existence of a mass/count distinction in Persian, the presence or absence of the plural marker or classifiers in the following data will be considered. The data in (1) and (2) show that both mass and count nouns in Persian can be targets of plural marking while having ‘stuff-dividing’ and ‘individualizing’ readings, respectively:

(1) qæhve-ha- ro be-bær sær-e miz.

coffee-PL-OM IMP-take-2SG on-EZ table

‘Take the coffees to the table.’

(2) tut-færængi-ha-ro tu-ye sæbæd gozašt-æm.

strawberry-PL-OM in-EZ basket put.PAST-1SG

‘I put the strawberries in the basket.’

³⁶ Farsi is another term for Persian although using the term Persian instead of Farsi has become highly favoured by modern linguists.

Example (3) reveals that pluralisation of mass nouns with a ‘large³⁷ amount of mass’ reading is possible in Persian:

(3) a. bærf-a-ro tu-ye otaq næ-yar.
snow-PL-OM in-EZ room NEG.IMP-bring-2SG
‘Don’t bring the snow into the room.’

b. šen-a-ye tu-ye čækm-æt-o ru-ye zæmin næ-riz.
sand-PL-EZ in-EZ boot-POSS-OM on-EZ floor NEG-IMP-pour-2SG
‘Don’t pour the sand in your boots on the floor.’

On the other hand, in direct object position, both count and mass nouns can occur without the plural marker while having underspecified mass or count value, as in (4) and (5):

(4) a. piš-æz nahar ketab xand va name nevešt.
before lunch book read.PAST-3SG and letter write.PAST-3SG
‘Before lunch, he read (some) books/a book and wrote (some) letters/a letter.’

b. bæʔd-æz nahar qæhve va šokolat xord.
after lunch coffee and chocolate have.PAST-3SG

³⁷ By using a ‘large amount of mass’, I mean a kind of unindividualized plural. Therefore, the amount of mass plural should not necessarily be large. Rather, it has the connotation of an unindividualized mass.

‘After lunch, he had coffee and chocolate.’

(5) anha zæn va bæčče dar-ænd.

they wife and kid have.PRES-3PL

‘They have wives and kids.’

Also, in predicative positions, nouns can appear without the plural marker with underspecified mass or count value, as in (6):

(6) ma nevisande hæst-im.

we writer be.PRES-1PL

‘We are writers.’

Both count and mass nouns with an atelic interpretation also occur without the plural marker, as in (7):

(7) u baraye yek saæt sib/čay xord.

he/she for one hour apple/tea have.PAST-3SG

‘He/She had apples/tea for an hour.’

In addition, classifiers occur optionally in indefinite [Card + (CL) + N] combinations, as in (8):

(8) a. lotfæf do (ta) mast be-xær.
Please two (CL) yogurt IMP-buy.PRES.2SG

‘Please buy two yogurts.’

b. pænj (jeld) dæftær xærid-æm.
five (CL^{volume}) notebook buy-PAST.1SG

‘I bought five notebooks.’

However, in informal Persian the plural marker occurs in a combination of [Card + CL + N-(PL)] with definite reading³⁸, as shown in (9):

(9) a. se ta čay-(ha)-ro ruye miz be-gozar.
three CL tea-(PL)-OM on table IMP-put-PRES-2SG

‘Put the three teas on the table.’

b. se ta ketab-(a)-ro koja gozašt-i?
three CL book-(PL)-OM where put-PAST-2SG

‘Where did you put the three books?’

Examining the data in (1) to (9) reveals the following puzzles: (i) Why does the plural marker in (1) to (3) select both count and mass nouns while in (4) to (7) it is not licensed with either of them? (ii) Why is the plural marker not licensed when

³⁸ I will discuss the co-occurrence of classifiers plural marking in detail in Chapter 4.

cardinals and optional classifiers co-occur, as in (8), but why is it licensed when both cardinals and classifiers co-occur, as in (9)?

The purpose of this chapter is to solve these puzzles, which revolve around the presence or absence of the plural marker or classifiers in such constructions and the sources of countability in Persian.

One of the theoretical terms discussed throughout this chapter is the ‘grammaticized mass/count distinction.’ When a ‘grammaticized mass/count distinction’ exists in a language, the source of the distinction can be detected in syntax, namely, if there is a projection of the functional category Number Phrase (NumP) in the nominal domain, according to Wiltschko (2007). The head of NumP must be occupied by number acting either as plural marking or as classifiers. If NumP exists in a language, there is a grammaticized mass/count distinction in that language. Nevertheless, Wiltschko argues that if there is no NumP in a language, the plural marker can attach to a nominal root as a root modifier.

Another theoretical term discussed in this chapter is the underspecification of nominal roots. According to Borer (2005), it is possible that “nouns (or stems...) come from the lexicon, or any other vocabulary list, neutral or underspecified with respect to the mass/count distinction, and their correct mass/count value is assigned in a mass structure or in a count structure” (p. 106).

Based on examples such as (1) and (2), I propose that plural marking in Persian is inflectional, and that NumP projects in Persian; consequently, the head of NumP is potentially occupied either by the plural marker or by classifiers. This shows that a grammaticized mass/count distinction is present in Persian. Based on

empirical evidence such as (3), I propose that the plural marker in Persian can be derivational when it has a modificational role, in which case it is attached to nominal roots³⁹.

Moreover, based on data such as (4) to (7), I propose that Persian nouns are sometimes ‘underspecified for mass/count value,’ namely the value of a noun as mass or count is not specified. This happens in some contexts containing bare singulars.

Referring to empirical evidence such as (8) and (9), I propose that Persian classifiers, regardless of whether they are full or empty, have portioning-out roles or individualizing roles as do Chinese classifiers. I discuss this in detail in Chapter 4.

In the following section, I provide a survey of the presence or absence of the Num Phrase in several languages, which leads to the existence or non-existence of a grammaticized mass/count distinction in these languages.

³⁹ Corbett (2000) argued that there are other uses of number other than the normal meaning of plural marking. For instance, there are special uses of number for distribution use. Corbett described an example of exaggerative plural from Finnish by Whitney (1956:202). When listing two or more single objects in an exaggerating speech of affirmative or boasting, sometimes the plural forms are used, as in (i). By using exaggerative plurals, it is emphasized that the person knows a lot:

- (i) Hän on lukenuat kreik-at ja Latina-t
3.SG AUX studied Greek-PL and Latin-PL
‘he/she has studied Greek and Latin’

The intensificative plural is another usage of special uses. Although it is similar to the exaggerative, there are different effects. Also, there is no need to have conjoined noun phrases. This usage in Russian is known as the ‘hyperbolic’ plural. It often shows dissatisfaction, as in (ii), an example from Russian speech (Krasil’nikova, 1990:85) when one only purse is visible:

- (ii) kto èto košel’k-i raskidyva-et
Who this purse-ACC.PL scatter-3.SG
‘Who’s been leaving purses lying around?’

3.3 The category Num and structural differences

The existence of the functional category Num(ber) has been the core feature in the discussion of countability and the mass/count distinction cross-linguistically. This section discusses whether the category NumP is present or absent in certain languages, namely, English, Halkomelem, Chinese, Armenian, and Ojibwe.

Two languages that differ with regard to NumP are English and Halkomelem. Wiltschko (2007) argues that the category NumP exists in English but is absent in Halkomelem. Such a difference can be detected in the function of plural marking; in particular, by verifying whether the plural marker selects only mass nouns, only count nouns, or both. In English, where NumP projects, the plural marker selects count nouns, but it does not select mass nouns, as shown in (10) and (11):

(10) a. There is a tree in my garden.

b. There are tree-**s** in my garden. (Wiltschko, 2007:2)

(11) a. There is wood in my garden.

b.*There are wood-**s** in my garden. (Wiltschko, 2007:2)

In Halkomelem, which does not have a NumP projection, the plural marker selects both types of nouns, called individuals and substance, which are shown in (12) and (13), respectively:

(12) a. tsel kw'éts-lexw mekw' te theqtheqát
1sg.s see-trans Q det.pl tree/tree.pl
'I have seen trees.'

b. tsel kw'éts-lexw te swóweles
1sg.s see-trans det boy.pl
'I have seen boys.'

(Wiltschko, 2007:3)

(13) a. tsel kw'éts-lexw te th'exth'éxet
1sg.s see-trans-3o det gravel.pl
'I saw a lot of gravel.'

b. tsel kw'éts-lexw te syiqyíq
1sg.s see-trans-3o det snow.pl
'I've seen a lot of snow.'

(Wiltschko, 2007:4)

Consequently, plural marking in English makes a distinction between mass and count nouns, whereas plural marking in Halkomelem does not distinguish between mass and count nouns.

Wiltschko (2007) proposes that the mass/count distinction is not grammaticized in Halkomelem, based on the absence of NumP, as shown in (14b), unlike in English where NumP appears, as shown in (14a):

(14) a. [_{DP} D [_{NumP} [**plural**] NUM [_{NP} N]]] → English

b. [_{DP} D [_{NP} N]] → Halkomelem

(Wiltschko, 2007:19)

Chinese is another language that requires a grammatical marker for countability. In Chinese, which has obligatory classifiers, countability is observed at the level of classifiers. Cheng and Sybesma (1999) argue that classifiers in Chinese have the function of making nouns countable, occupying the head of NumP. However, another view of Chinese-like languages with obligatory classifiers comes from Chierchia (1998), who claims that there is no mass/count distinction in such languages because the use of classifiers makes all nouns countable⁴⁰.

⁴⁰ Chierchia (1998) argues that features +/-arg and +/-pred constrain the way the categories N and NP are mapped. If an NP has a [+a] feature, mapping it onto things of type a is possible, but it is not possible if it has a [-a] feature.

According to Chierchia, nouns have a double nature. As quantifier restrictors, they can be predicates, and as names of kinds, they can be argumental. Therefore, he introduces the three possible settings of *the Nominal Mapping Parameter (NMP)* as follows:

- (i) *The Nominal Mapping Parameter (NMP)*: N ⇒ [±pred, ±arg]
 [-pred, +agr] every (lexical) noun is mass ⇒ Chinese

Mass/count languages

[+pred, +arg]	bare arguments	$\left\{ \begin{array}{l} \text{no article} \Rightarrow \text{Slavic} \\ \text{articles} \Rightarrow \text{Germanic} \end{array} \right.$
	allowed	
[+pred, -arg]	bare arguments	$\left\{ \begin{array}{l} \emptyset \Rightarrow \text{Italian} \\ \text{no } \emptyset \Rightarrow \text{French} \end{array} \right.$
	disallowed	

(Chierchia, 1998:400)

In NP [+arg, -pred] languages, as in Chinese, plural marking is absent, and numerals cannot co-occur with nouns directly. Rather, classifiers are required to individuate in contexts of counting. Therefore, in Chinese-like languages, numerals combine with classifiers while NPs being argumental:

Borer (2005) and Wiltschko (2007) assume that either plural marking or classifiers can derive countability. The NumP head in English is occupied by grammatical number as plural marking, but the NumP head in Chinese is occupied by grammatical classifiers. Therefore, the mass/count distinction in Chinese is realized by a grammatical classifier occupying the head of NumP, as in (15b), whereas the head of this functional projection is occupied by plural marking in English, as in (15a):

(15) a. $[_{DP} D [_{NumP} \text{[plural]}_{Num} [_{NP} N]]] \rightarrow$ English count N

b. $[_{DP} D [_{NumP} \text{[Number]}_{Num} [_{NP} N]]] \rightarrow$ Chinese count N

(Wiltschko, 2007:18)

Wiltschko assumes that when N moves to Num, the interpretation is mass as in (16):

(16) $[_{DP} D [_{NumP} [N] [_{NP} \bar{N}]]] \rightarrow$ mass N

(Wiltschko, 2007:18)

Classifiers are generally in complementary distribution with plural marking. A language like Chinese, however, which has grammatical classifiers, has no grammatical number. Nevertheless, Armenian and Persian are two languages that

-
- (ii) *NP* [+age, -pre] languages
- i. Generalized bare arguments
 - ii. The extension of all nouns is mass
 - iii. No PL
 - iv. Generalized classifier system

(Chierchia, 1998:354)

have complementary distribution of plural marking and classifiers, being explained in this section.

In Chinese all nouns require classifiers; therefore, it is believed by some linguists that Chinese nouns are all mass. Cheng and Sybesma (1999), however, argue that mass nouns in Chinese are not portioned out, while inherently count nouns are. According to Cheng and Sybesma, there are two types of classifiers in Chinese: ‘mass-classifiers’ (or ‘massifiers’) and ‘count classifiers’ for mass and count nouns, respectively, as in (17) and (18):

(17) san wan tan

three bowl soup

‘three bowls of soup’

(Cheng & Sybesma, 1999:514)

(18) san ben shu

three CL book

‘three books’

(Cheng & Sybesma, 1999:514)

A massifier like *wan* in (17) creates a unit of measure, but a count classifier as *ben* in (18) does not create a unit. Cheng and Sybesma argue that the difference between the two kinds of the classifiers in Chinese classifier system shows that there are two types of nouns: inherently portioned out nouns, as count nouns, and nouns that are not portioned out, as mass noun.

Moreover, in order to support that the classifier system reflects a mass/count distinction in Chinese, Cheng and Sybesma show the sensitivity of the two grammatical processes to classifiers. First, *de* as a modification marker can occur between a massifier and a noun, but it cannot occur between a count-classifier and a noun, as in (19) and (20):

(19) a. san bang (de) rou
 three CL-pound DE meat
 ‘three pounds of meat’

b. liang xiang (de) shu
 two CL-box DE book
 ‘two boxes of books’

(20) a. ba tou (*de) niu
 eight CL-head DE cow
 ‘eight cows’

b. jiu gen (*de) weiba
 nine CL DE tail
 ‘nine tails’

c. shi zhang (*de) zhouzi

ten CL DE table

‘ten tables’

(Chang & Sybesma, 1999:515-516)

Second, massifiers can be modified by some adjectives; however, these adjectives cannot modify count-classifiers, as in (21) and (22):

(21) a. yi da zhang zhi

one big CL-sheet paper

‘one large sheet of paper’

b. na yi xiao xishu shu

that one small CL-box book

‘that one small box of books’

(22) a. *yi da zhi gou

one big CL dog

b. *yi da wei laoshi

one big CL teacher

(Cheng & Sybesma, 1999:516)

In Armenian, classifiers also occupy the head of NumP. Both classifiers and plural marking occur in Armenian but in complementary distribution. Following Borer (2005), classifiers and plural marking cannot co-occur because either of them occupies the NumP head, as in (23):

(23) a. *Cardinal, no classifier, no plural*

yergu hovanoc uni-m
two umbrella have-1SG
'I have 2 umbrellas.'

b. *Cardinal, classifier, no plural*

yergu had hovanoc uni-m
two CL umbrella have-1SG
'I have 2 umbrellas.'

c. *Cardinal, no classifier, plural*

yergu hovanoc-ner uni-m
two umbrella-PL have-1SG
'I have 2 umbrellas.'

d. **Cardinal, classifier, plural*

*yergu had hovanoc-ner uni-m
two CL umbrella-PL have-1SG

‘I have 2 umbrellas.’

(Borer, 2005:117-18)

Nevertheless, in Halkomelem, because NumP does not project, classifiers and the plural marker are not in complementary distribution. Therefore, the plural marker being modificational can co-occur with classifiers, as in (24):

(24) tsel kw'éts-l-exw lhxwále siyó:lexwe

1.sg.s see-trans-3o three-cl old.people.pl

‘I saw three old people.’

(Wiltschko, 2007:24-5)

That the plural marker and classifiers in Halkomelem, unlike in Armenian, are not in complementary distribution is explained by the absence of the NumP.

Halkomelem classifiers are different from Chinese classifiers since in Chinese, which has a NumP projection, classifiers are obligatory, whereas in Halkomelem, the functional category NumP is not present, and the use of classifiers is optional, as in (25), where they are not required⁴¹:

(25) a. tsel kw'éts-lexw isále sth'ím

1sg.s see-trans two berry/berry.pl

‘I seen two berries.’

⁴¹ Although classifiers in Halkomelem are optional, the examples of optional classifiers are not available.

b. tsel kw'éts-lexw isále theqát

1sg.s see-trans two tree

'I seen two trees.'

(Wiltschko, 2007:23)

Ojibwe is another language that has plural marking occupying the head of the functional category NumP. Therefore, in Ojibwe, which does not have a classifier system, countability is realized at the level of number marking, which is different from Chinese, where it is realized at the level of classifiers. Mathieu (2007, 2011) argues that the functional category NumP projects in Ojibwe, and that a mass/count distinction exists in that language.

Nouns in Ojibwe are categorized into two main groups: animate and inanimate nouns. Based on empirical analysis by Mathieu (2007), some Ojibwe animate count nouns, such as *bagaan* 'nut', can be pluralized and can be interpreted as having separate individuals, i.e. 'several nuts/more than one nut' rather than 'pieces of nuts,' such as examples in (26):

(26) a. *bagaan/ag* 'nut' AN count

b. *miigwan/ag* 'feather' AN count

c. *maanadikoshens/ag* 'goat' AN count (Mathieu, 2007:6)

However, some other Ojibwe animate nouns, such as *maandaamin* 'corn', can be both mass and count, as in (27):

- (27) a. maandaamin/ag 'corn' AN mass/count
 b. waabigan/ag 'clay' AN mass/count
 c. aninaatig/oog 'maple' AN mass/count
 d. mikwam/iig 'ice' AN mass/count

(Mathieu, 2007:6)

Mathieu (2009) argues that there are no partitive phrases in Ojibwe, but number functions as both a massifier and a classifier. When animate nouns like those in (23) are pluralized, they have interpretations such as 'pieces of *x*', 'blades of *x*', 'portions of *x*', etc., as in (28) and (29):

- (28) a. maandaamin 'corn' - maandaamin-ag 'pieces of corn'
 b. semaa 'tobacco' - semaa-g 'chunks of tobacco'
 d. mikwam 'ice' - mikwam-iig 'pieces of ice'

(Mathieu, 2011:3)

- (29) a. mnoomin 'rice' - mnoomin-ag 'grains of rice'
 b. mashkosiw 'grass' - mashkosiw-ag 'blades of grass'
 c. waabigan 'clay' - waabigan-ag 'bits of clay'

(Mathieu, 2011:3)

Some Ojibwe inanimate nouns, such as *makizin*, 'moccasin' are count nouns and can be pluralized, as in (30):

- (30) a. akwaadawaagan/an ‘ladder’ IN count
 b. ishkwaandem/an ‘door’ IN count
 c. makizin/an ‘moccasin’ IN count

(Mathieu, 2007:6)

Some other Ojibwe inanimate nouns, such as *azhashki* ‘mud’, can have a count or mass interpretation, as in (31):

- (31) a. gausebeëgun/un ‘Indian-rubber’ IN count/mass
 b. mundáhminúshk/oon ‘straw/corn-straw’ IN count/mass
 c. (a)ki/in ‘earth’ IN count/mass

(Mathieu, 2007:6-7)

However, other Ojibwe inanimate nouns, such as *bimide* ‘oil’, are substances. Such nouns do not have plural forms. There is not even any pluralized form of these nouns with a ‘kind’ interpretation. These nouns cannot have a ‘serving/measure’ interpretation either, as shown in (32):

- (32) a. bimide ‘oil’ ~ *bimid-n IN
 b. (a)niibiishaaboo ‘tea’ ~ *(a)niibiishaaboo-n IN
 c. doodooshaaboo ‘milk’ ~ *doodooshaaboo-n IN
 d. nbiish ‘water’ ~ *nbiish-in IN

e. mini ‘pus’ ~ *mini-n IN
 (Mathieu, 2009:14)

The fact that some nouns in Ojibwe, such as the animate nouns listed in (27) and the inanimate nouns listed in (31), can be both count and mass is explained by Mathieu (2007), based on Borer (2005), by considering all nouns as mass while being portioned out for countability. Since there are no classifiers, determiners, or partitive quantifier phrases in Ojibwe for portioning out the undivided stuff, the function of stuff-dividing is accomplished by number realized at the projection of the category NumP. Such projection in Ojibwe is like the projection of NumP in English; nevertheless, there is no projection of DP in Ojibwe. In (33), Mathieu (2011) shows the projection of Num (by way of Div⁰) in Ojibwe for a plural noun, *niizh gaazhag* ‘two cats’. The plural performs Division while the noun raising to Div⁰ is performed through head movement. The counter added is the numeral *niizh* ‘two’:

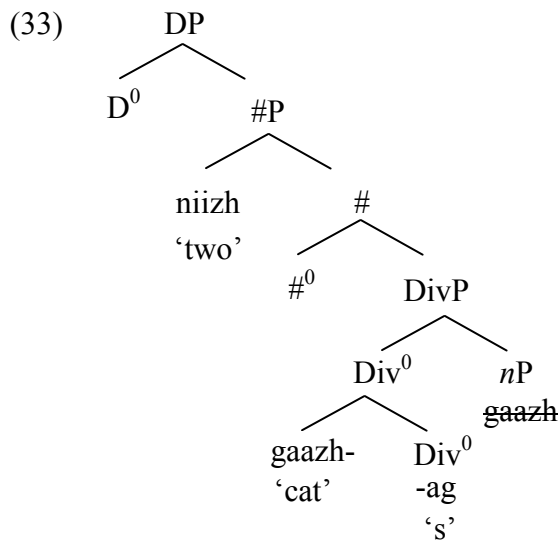

(Mathieu, 2011:5)

When DivP is absent, shown in (34), the interpretation of nouns is always mass. In (34), the noun *ziitigan* ‘salt’ does not raise, and the counter *niibina* ‘much’ is added:

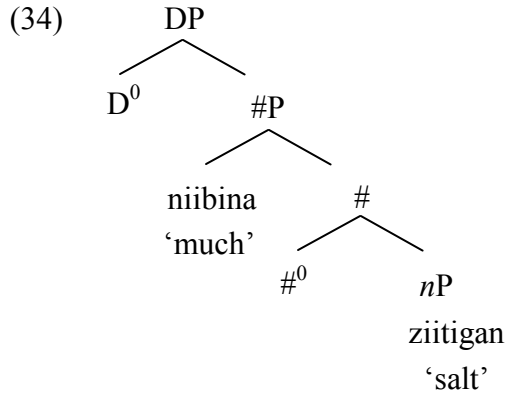

(Mathieu, 2011:5)

Unlike English, Ojibwe does not have measure phrases; however, in Ojibwe there are some Chinese-like massifiers, although they have diminished in use in recent years (Mathieu, 2011; following Valentine, 2001:502). These massifiers indicate measure when attached to numerals, as in (35):

- (35) a. *niizh-waatig* *nibi* a'. *niizh-waatig* *mist*
 two-CL water two-CL firewood
 ‘two bottles of water’ ‘two sticks of firewood’
- b. *niizh-weg* *zenibaa* c. *niizh-naagans zisbaakwad*
 two-CL silk two-cupfuls sugar
 ‘two pieces/sheets of silk’ ‘two cupfuls of sugar’

(Mathieu, 2011:5)

In Ojibwe, nouns appearing with mass-classifiers, as in (31), cannot be plural-marked; therefore, mass-classifiers are in complementary distribution with number marking. This is the same as count-classifiers and massifiers in Chinese being in complementary distribution (Mathieu, 2011; following Fassi Fehri & Vinet, 2007:8, ms. version). Accordingly, Mathieu (2011) assumes that in Ojibwe the same head, Div^0 , is occupied either by mass-classifiers or by number.

In sum, in some languages, the projection of the category NumP, which leads to the presence of a mass/count distinction, is realized through the use of either classifiers or plural marking filling the head of NumP.

The discussion of a mass/count distinction in Persian is presented in the following section.

3.4 The analysis

In order to discuss the existence of a mass/count distinction in Persian, first, I argue for the projection of the category NumP. Next, I discuss the modificational role of the plural marker as derivational plural marking, and finally, I discuss the underspecification of Persian nominal roots.

3.4.1 Grammaticized mass/count distinction in Persian

This section discusses the projection of NumP that leads to the presence of a grammaticized mass/count distinction in Persian. In order to determine whether or not NumP is present in Persian, I compare the characteristics of plural marking in English and Persian with regard to the presence or absence of NumP.

The data in (10) and (11), repeated below as (36) and (37), reveal that in English, either a count noun is singular, as in (36a), or it occurs with the plural marker, as in (36b); however, the plural marker does not accompany a mass noun, as in (37a):

(36) a. There is a tree in my garden.

b. There are tree-**s** in my garden.

(Wiltschko, 2007:2)

(37) a. There is wood in my garden.

b.*There are wood-**s** in my garden.

(Wiltschko, 2007:2)

Wiltschko (2007) argues that the plural marker, the \emptyset singular marker, or a noun, inducing a mass reading, can occupy the NumP in English, as in (38):

(38) a. [_{DP} D [_{NumP} [**plural/singular/“mass”**] [_{NP} N]]]

(Wiltschko, 2007:20)

Therefore, the NumP functional head in English is encoded to distinguish between plural, singular, and mass nouns.

Ghomeshi (2003) argues that NumP does not project in Persian. By comparing the properties of Persian and English, she concludes that a lexical count-mass distinction exists in Persian, but not at the level of NumP. The following Persian examples show that in direct object positions, bare singulars can occur, but

coerced mass interpretation is not necessarily induced if bare singulars are count nouns:

(39) a. (mæn) diruz qæhve xord-æm.

I yesterday coffee drink.PAST-1SG

‘I drank coffee yesterday.’

b. (mæn) diruz gušt poxt-æm.

I yesterday meat cook.PAST-1SG

‘I cooked meat yesterday.’

c. (mæn) diruz ketab xund-æm.

I yesterday book read.PAST-1SG

‘I read books [lit. book] yesterday.’

d. (mæn) diruz šir did-æm.

I yesterday lion see.PAST-1SG

‘I saw lions [lit. lion] yesterday.’ (Ghameshi, 2003:52)

These examples may provide an indication that a mass/count distinction does not exist in Persian; however, Ghameshi argues that this conclusion is not right because the data in (39) is just for direct object positions of bare nouns while

Persian and English can be compared to one another having some common properties in respect to count and mass nouns.

One of the properties of English in this respect is the existence of different quantifiers for count nouns than for mass nouns:

(40) *Quantifiers selecting count nouns*

- a. each [book_{COUNT}]
- b. few [books_{COUNT, PL}]
- c. *each [salt_{MASS}]
- d. *few [salt_{MASS}]

(Ghameshi, 2003:52)

(41) *Quantifiers selecting mass nouns*

- a. *much [book(s)_{COUNT, (PL)}]
- b. *a little [book(s)_{COUNT, (PL)}]
- c. much [salt_{MASS}]
- d. a little [salt_{MASS}]

(Ghameshi, 2003:53)

This type of distinction also exists in Persian, but Persian has fewer count and mass noun quantifiers:

(42) *Quantifiers selecting count nouns*

a. hær [ketab_{COUNT}]-i
each book -IND
'each book'

b. čænd-ta [ketab_{COUNT}]
some-CL book
'some books'

c. hær [næmæk_{MASS}]-i
each salt -IND

d. *čænd-ta [næmæk_{MASS}]
some-CL salt

(Ghameshi, 2003:53)

(43) *Quantifiers selecting mass nouns*

a. *ye zærre [ketab_{COUNT}]
one bit book

b. ye zærre [næmak_{MASS}]
one bit salt
'a bit of salt'

(Ghameshi, 2003:53)

Another property that mass nouns in English and Persian have in common is their appearance in the singular form. If mass nouns appear in the plural form in either language, the reading can be taxonomic or an understood quantity:

(44) a. *salts [unless we are talking about kinds of salt or packets of salt]

b. *næmæk-ha [" "]

salt-PL

(Ghameshi, 2003:53)

The third property common to both English and Persian is that indefinite articles in either language cannot be used with mass nouns except in readings of taxonomic and understood quantity:

(45) a. *a salt

b. *næmæk-i

salt-IND

(Ghameshi, 2003:53)

This comparison shows that Persian and English are similar in respect to a lexical mass/count distinction.

However, Ghameshi (2003) also argues that coercion⁴² effects are present in English, and the mass/count distinction is realized at the level of NumP, and

⁴² According to Ghameshi (2003), coercion is “the interpretation of count nouns as mass (the Universal Grinder) or mass nouns as count (the Universal Sorter)” (p. 53).

provides the following diagrams, which show NumP projections in English. These diagrams show the grammatical distinctions of nouns as count in (35a) and (35b) and mass in (46):

(46) *English*

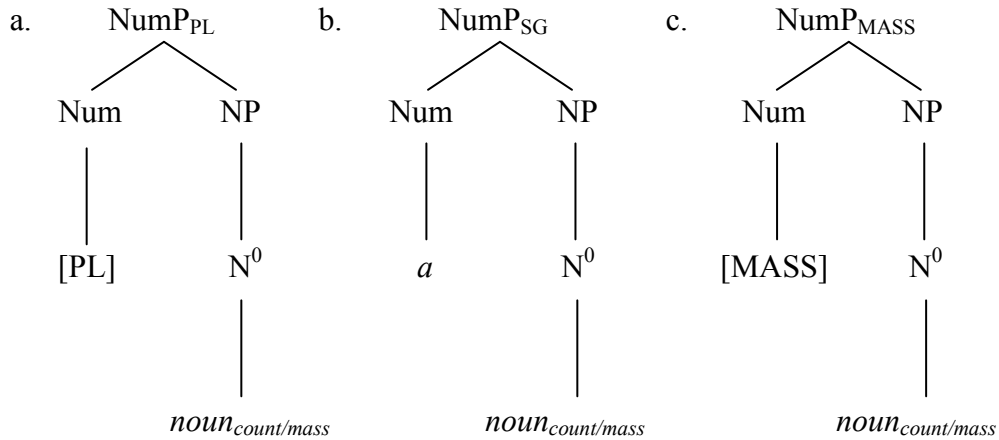

(Ghomeshi, 2003:54)

Each of the three diagrams above can have two readings. *Lions* as a plural count noun and *coffees* as a plural mass noun can be the readings of (46a). Diagram (46b) can be the representation of *a lion* as a singular count noun and *a coffee* as a singular mass noun. In (46c), the reading can be a mass count noun as in *lion* and a mass mass noun as in *coffee*.

Ghomeshi (2003) argues that non-referential nouns in Persian do not receive coercion effects. She further assumes that the NP nodes do not contain the count or mass specification of a noun, as represented in (47):

(47) *Persian*

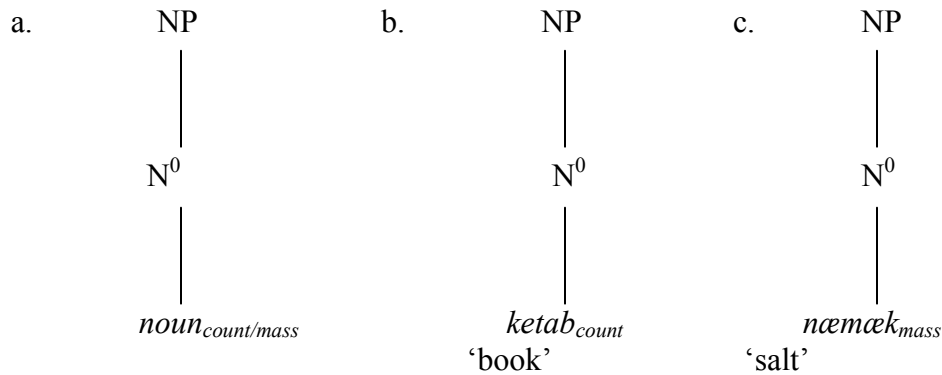

(Ghomeshi, 2003:54)

However, Ghomeshi argues that Persian also has the type of coercion effects in English but in classifier constructions. Persian has also been discussed as having countability at the level of classifiers. According to Ghomeshi (2003), “Chinese and Persian make the count/mass distinction at the level of the classifier” (p. 56); however, classifiers are not obligatory in Persian, as they are in Chinese. Although Ghomeshi (2003) argues that mass/count distinction in Persian is realized at the level of classifiers, she does not explain where the position of classifiers in Persian is. However, NumP in Persian does not project in her system, but she argues that Persian is like Chinese in employing classifiers. Therefore, I suppose the projection of classifiers in her system in the following diagram:

(48)

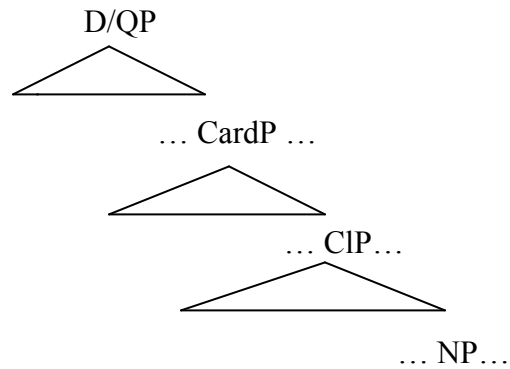

Ghameshi further discusses that Persian plural marker is not connected to NumP system, but it has relation to the determiner/quantifier (D/QP) system⁴³.

The following diagrams in English and Persian by Ghameshi (2003) also show the projection of NumP in English and its non-projection in Persian:

⁴³ Ghameshi (2003) argues that when triggering of a plural marker occurs in Persian, the noun is definite, as in (55) showing the licensing of plural marking:

(i) [_{DP} [_{NP} N-PL] Ø_{DEF}] (Ghameshi, 2003:57)

Ghameshi (2003) shows the licensing of plural marking in an indefinite nouns phrase:

(ii) [_{QP} [_{NP} N-PL]-i] (Ghameshi, 2003:67)

The configurations in (i) and (ii) for Persian indefinite nouns are in accordance with the following constraint by Ghameshi (2003:67):

(iii) *Constraint on Plural Marking in Persian*
Plural marking on nouns in Persian is licensed only if those nouns are contained within D/QPs.
(Ghameshi, 2003:67)

(49) a. *English*

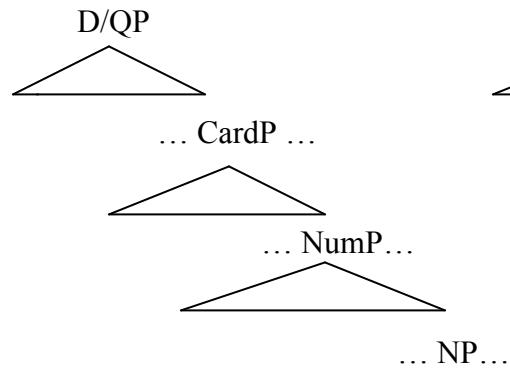

b. *Persian*

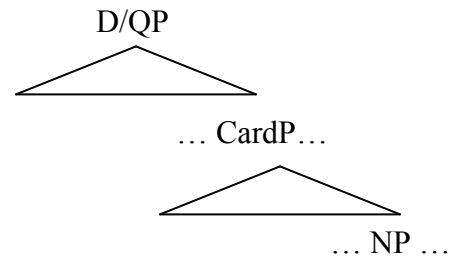

(Ghameshi, 2003:71)

Contrary to the claim that NumP does not project in Persian, the data in (1), repeated below as (50), is analyzed in order to determine whether there is a NumP projection in Persian:

(50) a. *qæhvə-ha- ro be-bær sær-e miz.*

coffee-PL-OM IMP-take-2SG on-EZ table

‘Take the coffees to the table.’

b. *tut-færæŋgi-ha ro tu-ye sæbæd gozašt-æm.*

strawberry-PL OM in-EZ basket put.PAST-1SG

‘I put the strawberries in the basket.’

The data in (50) indicates that the plural marker has the function of ‘stuff-dividing/portioning out’ or ‘individualizing’. In (50a), the plural marker has the role of portioning out *qæhvə* ‘coffee’. In (50b), the plural marker individualizes *tut-færæŋgi* ‘strawberry’. Therefore, I argue that when the plural marker functions as a

stuff-divider or individualizer, NumP projects in Persian, and the plural marker occupies the head of this projection.

The Persian plural marker occurs with both mass and count nouns with a ‘kind’ interpretation; therefore, it can function as a ‘kindifier’, as in (51) and (52). Therefore, not only count nouns but also mass nouns can be pluralized in such contexts.

(51) čay-ha va ængur-ha-ye iran xeili xoš taʔm hæst-ænd.

tea-PL and grape-PL-EZ Iran very good taste be.PRES-3PL

‘The teas and grapes from Iran are very tasty.’

(52) sib-ha va pænir-ha-ye kanada motenæve hæst-ænd.

apple-PL and cheese-PL-EZ Canada varied be.PRES-3PL

‘The apples and cheese from Canada are varied.’

The pluralisation of mass nouns with ‘portion’ or ‘kind’ reading in Persian is similar to mass noun pluralisation in English, which is a language with a grammaticized mass/count distinction. Even though mass noun pluralisation in English is not common, some mass noun can be pluralized with ‘serving/portion’ or ‘kind’ reading, as in (53a) and (53b), repeated from Chapter 1:

(53) a. There are only three waters available (tap, still, and sparkling water).

b. John ordered three waters (i.e. glasses, bottles etc...).

(Tsoulas, 2007:3)

I further support the claim that NumP projects in Persian by providing empirical evidence that classifiers in Persian function as grammatical number⁴⁴.

When cardinals are used in Persian, classifiers can optionally accompany them in an indefinite noun phrase combination of [Card + (CL) + N]. In (8), repeated below as (54), classifiers can optionally occur. In (9), repeated below as (55), however, the plural marker and classifier co-occur with definite reading in informal Persian:

(54) a. lotfæf do (ta) mast be-xær.

Please two (CL) yogurt IMP-buy-PRES.2SG

‘Please buy two yogurts.’

b. pænj (jeld) dæftær xærid-æm.

five (CL^{volume}) notebook buy-PAST-1SG

‘I bought five notebooks.’

(55) a. se ta čay-(ha)-ro ruye miz be-gozar.

three CL tea-(PL)-OM on table IMP-put-PRES-2SG

‘Put the three teas on the table.’

b. se ta ketab-(a)-ro koja gozašt-i?

three CL book-(PL)-OM where put-PAST-2SG

‘Where did you put the three books?’

⁴⁴ See Chapter 4 for a detailed analysis of classifiers in Persian.

In (54a), the (full or empty) classifier functions as a stuff-divider for *mast* ‘yogurt’. In (54b), the classifier has the role of individualizing *dæftær* ‘notebook’. Hence, I argue that either full classifiers or empty classifiers occupy the head of NumP. As a result, the analysis of classifiers in Persian also confirms that there is projection of NumP in Persian.

However, the co-occurrence of full classifiers and the plural marker in informal Persian, as in (55a) and (55b), in a definite noun phrase having a [Card + CL + N + (PL_{DEF})] combination, is the evidence that classifiers occupy the head of NumP because there is co-occurrence restriction of classifiers and plural marking. Because the plural marker is optional, it has a modificational role⁴⁵.

In sum, either the plural marker or full/empty classifiers occupy the head of NumP because they are in complementary distribution. This leads to the conclusion that there is a grammaticized mass/count distinction in Persian.

In the subsequent section, I present the analysis of modificational Persian plural marking as derivational plural marking.

3.4.2 Modificational plural marking in Persian

Having discussed the idea that plural marking in Persian is inflectional when occupying the head of NumP, in this section I argue that Persian plural marking has some derivational properties; therefore, the plural marker adjoins nominal roots as a modifier.

Persian plural marker can occur with mass nouns when a substance has been ‘poured’ or ‘spread’ (Sharifian & Lotfi, 2003). Sharifian and Lotfi found that mass

⁴⁵ See the detailed discussion of the co-occurrence of classifiers and plural marking in Chapter 4.

plurality of Persian substance nouns such as *ab* ‘water’ or *berenj* ‘rice’ is favoured by speakers when certain predicates such as ‘to spill’ or ‘to scatter’ have these nouns as their argument:

(56) *ab-a-ro æz kæf-e ašpazxune jam kon.*

water-PL-DO from floor-EZ kitchen gathering do

‘Wipe away the water from the kitchen floor.’

(Sharifian & Lotfi, 2003:235)

(57) *berenj-a-ro invær-o unvær næ-paš.*

rice-PL-OM here-and there NEG.throw.IMP.2SG

‘Don’t throw the rice here and there.’

(Sharifian & Lotfi, 2003:231)

Based on the empirical evidence in this study, Persian mass substance nouns with or without the plural marker can be used in such contexts, but the informants of the study emphasized that when there was ‘spreading’ or ‘being poured’, such as in patches, the plural form was preferred. Sometimes when such a mass noun is not the object of being ‘spread’ or ‘poured’ but is the object of being in a (large) gathered mass, the plural form is preferred. Consequently, the more spreading, pouring, or gathering a context indicates, the more the use of the unindividualizing plural form is preferred, as in (58b), and (59b):

(58) a. yæx-e ru-ye pænjera-ro pak=kon.

ice-EZ on-EZ window-OM clean=do.IMP-2SG

‘Clean the ice off the window.’

b. yæx-a-ye ru-ye pænjera-ro pak=kon.

ice-PL-EZ on-EZ window-OM clean=do.IMP-2SG

‘Clean the ice off the window.’

(59) a. mâmân âb-o bâ dasmâl ye guše jam kard.

mom water-do with cloth a corner gathering did

‘Mom gathered the water in a corner with a cloth.’

b. mâmân âb-â-o bâ dasmâl ye guše jam kard.

mom water-PL-do with cloth a corner gathering did

‘Mom gathered the water in a corner with a cloth.’

(Sharifian & Lotfi, 2003:231)

The interpretation acquired from each informant was a ‘large amount of mass’ for this kind of mass plural marking. Neither of the informants could interpret such examples as having ‘kind’, ‘portion’, ‘individualizing’, or ‘stuff-dividing’ reading. It is worth mentioning that on empirical grounds, all Persian mass nouns could be targets of plural marking, especially with a ‘large amount of mass’ interpretation. A large-amount-of-mass pluralisation in Persian has ‘cumulative reference’

(Acquaviva, 2006), preserving the identity of a noun when referring to a larger amount of a noun such as *water* or a larger set such as *books*; however, the ‘divisibility’ (Acquaviva, 2006) property of a noun is preserved as its parts get smaller, as in *water* keeping its identity as the amount gets smaller. In contrast, a word like *book* does not have a divisible reference since its parts cannot have the same property.

In sum, when there is a ‘large amount of mass’ interpretation, plural marking occurs with mass nouns in contexts such as being ‘spread’, ‘poured’, or ‘gathered’. This property of plural marking in Persian reveals that in these contexts NumP does not project and that Persian plural marking is derivational⁴⁶. Consequently, the plural marker adjoins nominal roots and has a modificational role, which induces a ‘large amount of mass’ interpretation.

Having discussed modificational plural marking in Persian, in the following section, I present the discussion of nominal roots in Persian.

⁴⁶ Although subject-verb agreement is one of the characteristics of inflectional plural marking, it is possible to have optional subject-verb agreement in contexts of a ‘large amount of mass’ when subjects are inanimate mass nouns, as in (i). The optionality of subject-verb agreement in such contexts with inanimate mass subjects shows that plural marking is not inflectional, yet it is derivational.

- (i) a. roqæn-a xali=šod kaf-e mašin.
 oil-PL empty/spill=become-PAST.3SG floor-EZ car
 ‘The oil spilled/emptied over the car floor.’
- b. roqæn-a xali=šod-æn kaf-e mašin.
 oil-PL empty/spill=become-PAST.3PL floor-EZ car
 ‘The oil spilled/emptied over the car floor.’

3.4.3 Persian nominal roots

Following the claim by Borer (2005) that nominal roots are underspecified for mass/count value, I show that bare singulars in predicative position in Persian are underspecified for mass or count value, as in (6), repeated below as (60), and as in (61):

(60) ma nevisande hæst-im.

we writer be.PRES-1PL

‘We are writers.’

(61) anha moallem hastænd.

they teacher be.PRES-3PL

‘They are teachers.’

(Windfuhr, 1979:32)

The data in (4), repeated below as (62), and in (63) reveal that bare singulars in direct object positions also do not have a mass or count value.

(62) a. piš-æz nahar ketab xand va name nevešt.

before lunch book read.PAST-3SG and letter write.PAST-3SG

‘Before lunch, he read (some) books/a book and wrote (some) letters/a letter.’

b. bæʔd-æz nahar qæhve va šokolat xord.

after lunch coffee and chocolate have.PAST-3SG

‘After lunch, he had coffee and chocolate.’

(63) emruz sib, porteqal, moz, šekær, qæhve, væ čay xærid-æm.

today apple orange banana sugar coffee and tea buy.PAST-1SG

‘Today I bought apples, oranges, bananas, sugar, coffee, and tea.’

Bare nouns, such as *ketab* ‘book’ and *name* ‘letter’ in (62a), *qæhve* ‘coffee’ and *šokolat* ‘chocolate’ in (62b), and *sib* ‘apple’, *porteqal* ‘orange’, *moz* ‘banana’, *šekær* ‘sugar’, *qæhve* ‘coffee’, and *čay* ‘tea’ in (63) are not specified as being count or mass because NumP is not projected in these contexts and because there is no head of NumP to be encoded for such a difference.

However, the count or mass value of the underspecified noun is assigned in a count or mass structure (Borer, 2005). When a speaker refers to the nouns in (63) for the second time, namely, when nouns become definite, followed by the definite object marker *ra/ro*, the plural marker occurs with count nouns, as in (64), but it does not occur with mass nouns, as in (65). This shows that the occurrence or non-occurrence of the plural marker in direct object position assigns count or mass value to them:

(64) lotfæn sib-ha, porteqal-ha, væ moz-ha-ro be-gozar tu-ye
 please apple-PL orange-PL and banana-PL-OM IMP-put-2SG in-EZ
 yæxčal.
 fridge
 ‘Please put the apples, the oranges, and the bananas in the fridge.’

(65) lotfæn šekær, čay, væ qəhva-ro be-gozar tu-ye kabinet.
 please sugar tea and coffee-OM IMP-put-2SG in-EZ cabinet
 ‘Please put the sugar, tea, and coffee in the cabinet.’

The other data that support underspecification of nominal roots in Persian is provided in (7), repeated below as (66a), which has an atelic interpretation:

(66) a. u baraye yek saæt sib/čay xord.
 he/she for one hour apple/tea have.PAST-3SG
 ‘He/She had apples/tea for an hour.’

b. u do (ta) sib/yek fenjan čay-ra dær yek saæt xord.
 he/she two CL apple/one cup tea- OM in one hour have.PAST-
 3SG
 ‘He/She had two apples/a cup of tea in an hour.’

Comparing and contrasting (66a), with an atelic interpretation, and (66b), with a telic interpretation, it is concluded that because NumP is absent in atelic contexts

in Persian, the count and mass values of nouns have not been assigned, whereas such values are assigned in telic contexts.

Persian nouns with atelic interpretations, as in (66a), can be contrasted with English count nouns and mass nouns having atelic interpretations, as in (67) and (68), respectively:

(67) Kim ate apples this afternoon (for an hour) (*in an hour).

(Borer, 2005:120)

(68) Kim ate meat (*in an hour).

(Borer, 2005:121)

In English, count nouns with atelic interpretations occur as bare plurals, but mass nouns with atelic interpretations occur as bare mass nouns. This shows that in English the nouns with atelic interpretations have their values specified as count or mass. However, both count and mass nouns in Persian occur as bare nouns in atelic contexts, not only with undetermined quantities, but also with no count or mass value.

In sum, when there is underspecification of nouns in Persian, they appear with no count or mass value. The data in this section show the underspecification of Persian nouns in certain predicative and direct object positions as well as in atelic structures. When there are bare nouns in these positions, their mass or count value is not assigned; consequently, they are underspecified for a mass/count distinction.

The underspecification of nouns in Persian is compatible with Wiltschko's (2007) assumption that when there is no functional NumP head, the count or mass value of a noun is not encoded. Consequently, nouns appear as underspecified for mass/count values in Persian when there is no NumP projection.

3.5 Summary

Having discussed the role of Persian classifiers and plural marking in individualizing nouns, I argue that the functional category NumP projects in Persian. Classifiers, as in Chinese-like languages, and the plural marker, as in English-like languages, occupy the head of NumP in Persian, but they are in complementary distribution. However, classifiers in Persian, unlike Chinese classifiers, are optional. Hence, the co-occurrence restriction exists between full/empty classifiers and the plural marker. Because the functional category NumP projects in Persian, there is a grammaticized mass/count distinction in Persian.

However, when the modificational plural marker targets a mass noun, it denotes a 'large amount of mass' interpretation. Therefore, the functional category NumP is not projected and the plural marker as a modifier adjoins a nominal root. This is compatible with the derivational properties of Persian plural marking discussed in Chapter 2. Also, the underspecification of nominal roots for mass or count value indicates the non-projection of NumP when there are underspecified nouns in predicative and direct object positions as well as in atelic structures in Persian.

In Chapter 4, I explore the role of classifiers in Persian in detail.

Chapter 4: The role of classifiers in Persian

4.1 Introduction

In this chapter, I investigate the role of classifiers in Persian and their relationship to NumP. As discussed in Chapters 2 and 3, the functional category NumP is present in Persian when the plural marker occupies the head of NumP. Consequently, there is a grammaticized mass/count distinction in Persian. As discussed in Chapter 3, Borer (2005) argues that when there is a projection of the functional category NumP in a language, the NumP head is occupied either by the plural marker or by grammatical classifiers, as in English-like languages and Chinese-like languages, respectively.

This chapter focuses on the question of whether classifiers in Persian have a role in individualizing nouns, as do Chinese-like classifiers. Because Persian classifiers and plural markers are in complementary distribution, I propose that Persian classifiers, like Chinese classifiers, occupy the head of NumP and function as grammatical number in individualizing nouns. Consequently, either grammatical number or grammatical classifiers can occupy the head of NumP in Persian.

Persian classifiers can occur in an indefinite noun phrase having a [Card + (CL) + N] combination; nevertheless, the occurrence of the plural marker in this combination renders it ungrammatical. Consequently, I propose that either a classifier or an empty classifier occupies the head of NumP in Persian.

Persian plural marking can optionally co-occur with a classifier in a definite noun phrase having a [Card + CL + N + (PL_{DEF})] combination. Because there is a

co-occurrence restriction of classifier and plural marking in a nominal phrase, I propose that the head of NumP is not occupied by the plural marker. The full classifier, however, occupies the NumP head. Since the definite plural marker is optional, I propose that it has a modification role.

The following examples show the possible occurrences of classifiers in Persian. Example (1a) shows that a classifier can occur optionally in an indefinite noun phrase having the combination [Card + (CL) + N]. In informal register, the presence of the classifier *ta*, as the default classifier, is almost obligatory; however, it is quite formal when it is absent. Example (1b), however, shows that the plural marker does not occur with a full classifier or an empty classifier for the intended meaning. Nevertheless, example (1c) shows the optional occurrence of the plural marker in a definite noun phrase while the classifier is not optional. This combination is quite informal in Persian:

(1) a. se (ta) mæqaze

three (CL) store

‘three stores’

b. *se (ta) mæqaze-ha

three (CL) store-PL

‘three stores’

c. se *(ta) mæqaze-(ha)
three *(CL) store-(PL)
'the three stores'

This chapter is organized as follows. In the next section, I discuss the distribution of classifiers cross-linguistically. In section 3, I investigate the distribution of classifiers in Persian. In section 4, I address the relationship between classifiers and plural marking in Persian and other languages.

4.2 Cross-linguistic role of classifiers

In this section, I discuss the distribution of classifiers in some classifier languages such as Japanese, Chinese, and some Southeast Asian languages, in order to compare and contrast these distributions to that of Persian. In some languages, countability is at the level of plural marking, such as in English; however, some languages require classifiers to have nouns countable, as in Chinese-like languages.

A language like Chinese, which has grammatical classifiers, has no grammatical number. Borer (2005) argues that in Chinese and Japanese, as in (2) and (3), the classifiers are present while the plural marking is absent:

(2) a. y 1 mi (Chinese)
one CL rice
'one grain of rice'

b. yi ge ren
one CL person

c. shenme qian
much money (*shenme*: literally ‘what’) (Borer, 2005:86)

(3) a. denwa ni dai (Japanese)
telephone two CL
‘two telephones’

b. denwa ni hon
telephone two CL
‘two telephone calls’

c. jin ni kiro
gold two kilogram
‘two kilograms of gold’ (Borer, 2005:87)

As shown in (2), all types of nouns, both mass and count, require classifiers in Chinese. Cheng and Sybesma (2005) compare Chinese to other languages, such as English and Dutch, which require measure words in order to make mass nouns countable, as in (4):

(4) a. a glass of water

b. een glas water (Dutch)

a glass water

c. yat bui seoi (Cantonese)

one cup water

(Cheng & Sybesma, 2005:272)

Cheng and Sybesma (1999) compare mass nouns in English to all nouns in Chinese. In English, a measure phrase such as ‘*a glass*’ in the nominal phrase ‘*a glass of milk*’ or ‘*every grain*’ in ‘*every grain of sand*’ are needed to make nouns countable. However, the difference between English and Chinese nouns is that all nouns in Chinese, even those having count counterparts in English, need measure phrases or classifiers, which are both referred to as classifiers. Because all nouns in Chinese require classifiers, some linguists have assumed that all Chinese nouns are mass nouns. Nevertheless, Cheng and Sybesma (1999) argue that in Chinese, count nouns are inherently partitioned whereas mass nouns are not. Both types of nouns in Chinese have the characteristic of needing classifiers in order to be countable. For this reason, Cheng and Sybesma introduce two types of classifiers in Chinese: (i) ‘massifiers’, which is a short form for mass-classifiers, and (ii) ‘count classifiers’. A massifier creates a measure unit while a count classifier names a unit used for an entity, as in (5) and (6), respectively, in Mandarin:

(5) a. san ping jiu

three bottle liquor

‘three bottles of liquor’

b. san ba mi

three handful rice

‘three handfuls of rice’

(Cheng & Sybesma, 1999:514)

(6) a. san ge ren

three CL people

‘three persons’

b. san zhi bi

three CL pen

‘three pens’

(Cheng & Sybesma, 1999:514)

Cheng and Sybesma (2005) state that the classifier *ge*, as shown in (6a), which refers to a word that means ‘bamboo’, is used for things like humans that are long or tall. Therefore, depending on the properties or shapes of nouns, there are different count classifiers in Chinese languages. According to Cheung et al. (2009), *ge*, as a default classifier in Mandarin, is the most frequent. Most of the classifier

languages have default classifiers for nouns that are novel or nouns that do not have any specific classifier.

Cheng and Sybesma (2005) show how in Chinese-like languages count nouns are the same as mass noun in requiring a counter as a classifier. Otherwise, nominal expressions, such as those in (7), without classifiers for ‘books’, are ungrammatical:

- (7) a. yi *(ben) shu (Mandarin)
b. i *(paŋ) si (Wenzhou)
c. jit *(bun) zhu (Southern Min)
d. yat *(bun) syu (Cantonese)
one CL^{volume} book

(Cheng & Sybesma, 2005:273)

That all nouns in Chinese require classifiers in order to be countable does not imply that all nouns are mass. In Chinese, there is a modification marker, *de*, which can be an explanation for a semantic/lexical distinction in nouns; namely, it can occur between mass classifiers and mass nouns, but it does not occur between count classifiers and count nouns, as in (8) and (9)⁴⁷:

- (8) a. san bang (de) rou
three CL-pound DE meat
‘three pounds of meat’

⁴⁷ These examples are repeated from Chapter 3.

b. liang xiang (de) shu
two CL-box DE book
'two boxes of books'

(Cheng & Sybesma, 1999:515)

(9) a. ba tou (*de) niu
eight CL-head DE cow
'eight cows'

b. jiu gen (*de) weiba
nine CL DE tail
'nine tails'

c. shi zhang (*de) zhuozi
ten CL DE table
'ten tables'

(Cheng & Sybesma, 1999:516)

Also, Cheng and Sybesma (1999) point out that some adjectives, such as *da* 'big', do not occur with count classifiers, yet they occur with massifiers and modify them, as in (10) and (11)⁴⁸:

⁴⁸ These examples are repeated from Chapter 3.

(10) a. yi da zhang zhi
one big CL-sheet paper
'one large sheet of paper.'

b. na yi ziao ziang shu
that one small CL-box book
'that one small box of books'

(Cheng & Sybesma, 1999:516)

(11) a. *yi da zhi gou
one big CL dog

b. *yi da wei laoshi
one big CL teacher

(Cheng & Sybesma, 1999:516)

Cheng and Sybesma (1999) argue that the co-occurrence of the modificational marker *de*, as in (8a), and the adjective *da*, as in (10a), with mass nouns in Chinese is an indication that not all nouns are mass. Rather, it reveals there is a mass/count distinction in Chinese.

Most of the classifier languages have a unique characteristic, which is the co-occurrence of classifiers with numerals. In many Southeast Asian languages, classifiers accompany numerals (Greenberg, 1972; Burling, 1965). Greenberg (1972) argues that mass nouns in non-classifier languages with a mass/count

distinction do not have direct constructions with numerals; rather measures such as *cup* in ‘one cup of water’ or *gallons* in ‘two gallons of water’ are required. Cheung et al. (2009) point out that in Mandarin Chinese there is no direct co-occurrence of a numeral and a noun. Rather, a noun needs a unitizer, meaning a classifier for counting. In English just mass nouns require a massifier as in *two pieces of toast*. Therefore, the equivalent of *three pens* in Mandarin is *san zhi bi* meaning ‘three stick pen’, where the numeral *san* ‘three’ and the classifier *zhi* ‘stick’ are both required.

Simpson (2005) explains that there are two views about classifiers and numerals. According to some works, classifiers and numerals belong to two different functional heads. However, according to other works, numerals and classifiers belong to one functional head⁴⁹.

Simpson (2005) notes that the combination of classifiers and numerals is very common among Southeast Asian languages; however, a less common use comes from a subset of these languages, where numerals are not used in the classifier-NP combination, namely, a classifier can occur for the purpose of individuating an NP., as in (12) in Vietnamese, (13) in Hmong, and (14) in Nung:

(12) Nguoi chong rat tot. (Vietnamese)

CL husband very good

‘The husband was very good.’

(Daley, 1998:65)

⁴⁹ Simpson (2005) argues that perhaps numerals and classifiers belong to functional heads that are adjacent, namely, Num⁰ selects a complement CLP.

(13) Tus tsov tshaib tshaib plab. (Hmong)

CL tiger hungry hungry stomach

‘The tiger was very hungry.’

(Jaisser, 1987:171)

(14) Leo tu me da tu po va ... (Nung)

Then CL wife scold CL husband say

‘Then the wife scolded the husband and said...’

(Saul & Wilson, 1980:160)

However, according to Simpson (2005), when there is no direct individuation and the specification of numeral is rather vague, the occurrence of numerals without classifiers is possible. Hopper (1986) points out that in Malay when classifiers do not accompany numerals, individuation is not necessary, and the specification of the numeral is vague and approximate, as in (15):

(15) Adalah dua tiga pondok kechil- kechil bersama-sama dekat

be 2 3 hut small small together near

rumah Temenggong.

house Temenggong

‘There were two or three small huts close together near Temenggong’s house.’

(Simpson, 2005:809)

Simpson (2005) also mentions that in Vietnamese, as argued by Bisang (1999), when there is no individuation of a counted noun, the classifier is omitted, as in (16):

(16) nha ba phong
house 3 room
'a three-room house'

(Simpson, 2005:809)

Simpson argues that the patterns, as in (12), (13), (14), (15), and (16), indicate that the formal functions of numerals and classifiers are distinct. Therefore, it is assumed that they have distinct syntactic heads.

Another argument to support the hypothesis that numeral and classifiers belong to two heads comes from Nung, a language from northern Tai. Simpson (2005) shows how the numeral 'one' occurs after a noun and is not followed directly by a classifier, as in (17):

(17) An ahn tahng nuhng ma.
take CL chair one come
'Bring a chair.'

(Saul & Wilson, 1980:56)

Based on these patterns, Simpson (2005) concludes that numerals and classifiers have different functions, so they should belong to separate functional heads.

In the following section, I will investigate the distribution of classifiers in Persian in order to establish common ground among the classifier languages discussed.

4.3 Distribution of classifiers in Persian

In this section, I explore the distribution of classifiers in Persian to compare and contrast the characteristics of Persian classifiers to those of most classifier-like languages.

There are two types of classifiers in Persian, as in Chinese (Cheng & Sybesma, 1999): (i) measure phrases or massifiers for making mass nouns countable, as in (18), and (ii) count classifiers for counting count nouns, as in (19). However, I use the term ‘classifiers’ to refer to both.

(18) a. dæh livan nušabe

ten CL^{glass} drink

‘ten glasses of drink’

b. se kase sup

three CL^{bowl} soup

‘three bowls of soup’

(19). a. hæft šaxe gol
seven CL^{branch} flower
'seven flowers'

b. pænj hælqe čah
five CL^{circle} well
'five wells'

The most important characteristic of Persian count classifiers is that they have optional uses. Gebhardt (2008) points out that in Persian, as in most classifier languages, the use of classifiers is optional to a great degree, as illustrated in (20):

(20) a. pænj (ta) doxtær Persian
five (CL) girl
'five girls'

b. dua (ekor) kuda Indonesian
two (CL) horse
'two horses'

(McDonald, 1967)

Gebhardt (2008) argues that it sounds somewhat bookish if classifiers are not used in Persian. In informal Persian, the use of the classifier *ta* is almost obligatory

with numerals, as in (21). In formal Persian, however, the use of classifiers can be optional, as in (22) and (23):

(21) do ta sib

Two CL apple

‘two apples’

(22) se (færvænd) helicopter

three (CL) helicopter

‘three helicopters’

(23) pænʃ (qæbze) æslæhe

five (CL^{hilt}) weapon

‘five weapons’

The fact that the use of classifiers in Persian is optional⁵⁰, as in (24) and (25), distinguishes Persian classifiers from classifiers in languages where they do not have optional uses, as in Chinese-like languages, as shown in (7), repeated below as (26):

(24) se (dæstgah) mašin xærid-e-šod.

three (CL^{set}) car buy.PASTPART-become.PAST-3SG

⁵⁰ The difference between the presence or absence of the Persian classifier *ta* is related to the informal and formal registers, respectively. However, it is almost obligatory to use the classifier *ta* in informal register.

‘Three cars were bought.’

- (25) hæft (ta) medad xærid-æm.
seven (CL) pencil buy.PAST-1SG
‘I bought seven pencils.’

- (26) a. yi *(ben) shu (Mandarin)
b. i *(paŋ) si (Wenzhou)
c. jit *(bun) zhu (Southern Min)
d. yat *(bun) syu (Cantonese)
one CL^{volume} book

(Cheng & Sybesma, 2005:273)

The classifier *ta* used in example (25) is a default classifier in Persian, which is generally used in informal registers of the language. This classifier, used for counting more than one instances of a noun, is pretty much obligatory in informal Persian. Another default classifier generally used in informal language is *dane/dune* ‘grain’, used for counting a single instance of a noun, as in (27); therefore, the classifier *ta* cannot be used in this case. Dropping the classifier *dane/dune* in informal language is quite common, which is different from the use of the classifier *ta* being obligatory in informal register.

(27) ye (dune) sib va ye dune porteqal xærid-æm.

one (CL^{grain}) apple and one CL^{grain} orange buy.PAST-3SG

‘I bought an apple and an orange.’

Persian has a detailed system of classifiers realized as free morphemes. Some classifiers, taken from Ahmadi-Givi and Anvari (1997), are shown in (28) and (29):

Persian Classifiers (I)

(28) a. bab for counting houses, shops, and inns

‘door’

b. tup for counting fabric

‘bolt’

c. joft for counting shoes, socks, etc.

‘pair’

d. dæst for counting clothes, dishes, cutlery, etc.

‘set’

e. dæstgah for counting cars, radios, TVs, etc.

‘machinery’

f. dojin for counting any pack of 12 items

‘dozen’

g. ræʔs for counting cows, sheep, goat, donkeys, etc.

‘head’

h. sær for counting individuals in a family

‘head’

- i. taqe for counting scarves, blankets, and fabric
 ‘piece’
- j. færvænd for counting ships, airplanes, and helicopters
- k. qæbze for counting light weapons such as bullets, rifles, and knives
 ‘hilt’
- l. qætʔe for counting lands and carpets
 ‘piece’
- m. qævare for counting lands and fabric (for a piece of clothing)
 ‘cut’
- n. næfær for counting individuals
 ‘person’

Persian Classifiers (II)

- (29) a. æsle for counting trees
- b. tæxte for counting carpets, blankets, etc.
 ‘sheet’
- c. tæn for counting individuals
 ‘body’
- d. jeld for counting books and notebooks
 ‘volume’
- e. hælqe for counting wells, subterranean canals, films, and tapes
 ‘circle’

- f. *dæhæne* for counting shops
‘mouth’
- g. *rešte* for counting necklaces and bracelets as well as subterranean
‘range’ canals and wells
- h. *zænjir* for counting elephants
‘chain’
- i. *sæng* for counting water for irrigating and mills
‘stone’
- j. *šaxe* for counting wires, chandeliers, etc.
‘branch’
- k. *ærrade* for counting cannons
‘(gun-) carriage’
- l. *qors* for counting bread
‘round loaf’
- m. *qællade* for counting dogs, lions, etc.
‘leash’
- n. *mojallæd* for counting books and notebooks
‘volume’

In Persian, as in many classifier languages, the default classifier *ta* always co-occurs with cardinals in a [Card + CL + N] combination, as in (30a) and (31a). As a result, a [CL + N] combination is never possible in Persian, as shown in (30b) and (31b):

(30) a. do ta nan
two CL bread
'two breads'

b. *ta nan
CL bread

(31) a. čahar ta sændæli
four CL chair
'four chairs'

b. *ta sændæli
CL chair

In Persian, a classifier accompanies a cardinal in an indefinite nominal phrase combination of [Card + CL + N], as in (32):

(32) bist raʔs gusfænd
twenty CL^{head} sheep
'twenty sheep'

When a Persian classifier occurs in an indefinite nominal phrase combination of [Card + CL + N], plural marking is absent, as in (33a), (34a), and (35a);

however, the plural marker is present in a definite nominal phrase⁵¹, as in (33b), (34b) and (35b):

(33) a. *dæh ta hævapeyma dær forodgah bud-ænd.*
ten CL airplane in airport be.PAST-3PL
'Ten airplanes were at the airport.'

b. *dæh ta hævapeyma-ha dær forodgah bud-ænd.*
ten CL airplane-PL in airport be.PAST-3PL
'The ten airplanes were at the airport.'

(34) a. *do ta ketab bayad be-xær-æm.*
two CL book must SBJ-buy.PRES-1SG
'I must buy two books.'

b. *do ta ketab-ha-ra bayad be-xær-æm.*
two CL book-PL-OM must SBJ-buy.PRES-1SG
'I must buy the two books.'

(35) a. *do ta danešju sæbt-e-nam=kærd-ænd.*
two CL student register-EZ-name=do.PAST-3PL
'Two students got registered.'

⁵¹ The co-occurrence of the plural marker and the default classifier *ta* in definite nominal phrases is mostly used in informal register. The definite combination of the plural marker and classifiers will be discussed in §4.4.

b. do ta danešju-ha sæbt-e-nam-kærd-ænd.

two CL student-PL register-EZ-name=do.PAST-3PL

‘The two students got registered.’

However, in an indefinite nominal phrase combination of [N + PL], there is no classifier, as in (36a), (37a), and (38a). Accordingly, the occurrence of a [cardinal + classifier + PL + IND] combination is ungrammatical, as in (36b), (37b) and (38b):

(36) a. hævapeyma-ha-yi dær forodgah bud-ænd.

airplane-PL-IND in airport be.PAST-3PL

‘There were (some) airplanes at the airport.’

b. *pænɟ færvænd hævapeyma-ha-yi dær forodgah bud-ænd.

five CL airplane-PL-IND in airport be.PAST-3PL

(37) a. bayad ketab-ha-yi be-xær-æm.

must book-PL-IND SBJ.buy.PRES-1SG

‘I must buy (some) books.’

b. *bayad do jeld ketab-ha-yi be-xær-æm.

must two volume book-PL-IND SBJ-buy.PRES-1SG

(38) a. danešju-ha-yi sæbt-e-nam=kærd-ænd.

student-PL-IND register-EZ-name=do.PAST-3PL

‘Some students got registered.’

b. *do ta danešju-ha-yi sæbt-e-nam=kærd-ænd.

two CL student-PL-IND register-EZ-name=do.PAST-3PL

Therefore, classifiers are in complementary distribution with plural marking in indefinite nominal phrases.

However, plural marking can optionally be present in a combination of [Card + CL + N + (PL_{DEF})] if it induces definiteness, but classifiers are not optional, as shown in (39), (40), and (41):

(39) dæh *(færvænd) hævapeyma(-ha)-ra dær forodgah did-ænd.

ten *(CL) airplane(-PL_{DEF})-OM in airport see.PAST-3PL

‘They saw the ten airplanes at the airport.’

(40) do *(jeld) ketab(-ha)-ra xærid.

two *(CL^{volume}) book(-PL_{DEF})-OM buy.PAST-3SG

‘He/She bought the two volumes of the books.’

(41) do *(ta) danešju(-ha)-ra dævæt-kærd-æm.

two *(CL) student(-PL_{DEF})-OM invite-do.PAST-1SG

‘I invited the two students.’

In sum, while optionality is one of the major characteristics of Persian classifiers, in indefinite nominal phrases, there is complementary distribution of classifiers with plural marking in Persian. Nevertheless, plural marking in Persian can co-occur with full classifiers if the plural marker induces a definite reading.

In the next section, I discuss the relationship between classifiers and plural marking in some languages, such as Halkomelem, Armenian, and Persian.

4.4 Classifiers and plural marking

Persian is a classifier language in which cardinals accompany classifiers. Ghomeshi (2003) argues that Persian has countability at the level of classifiers. Nevertheless, unlike in Chinese, classifiers in Persian are not obligatory. There are some languages that have countability at the level of both plural marking and classifiers, such as Armenian and Persian; nevertheless, in these languages classifiers are generally in complementary distribution with plural marking. Therefore, it is interesting to investigate whether Persian classifiers occupy the head of NumP and whether they individualize nouns as plural marking does. In addition, it is interesting to know why they can be optional if they occupy the head of NumP. Following Borer (2005) and Wiltschko (2007), I propose that plural marking and classifiers occupy the head of NumP, as such they are in complementary distribution. Moreover, I propose that when a classifier is empty, the head of NumP is occupied by an empty classifier.

In order to investigate the characteristics of classifiers in Persian, I will compare and contrast countability in Persian with countability in English, Chinese, Halkomelem, and Armenian discussed in Chapter 3.

Wiltschko's (2007) assumption is that "countability can be derived in at least one of the two ways: by means of classifiers or by means of plural marking" (p. 18). In English, grammatical number, in the form of plural marking, occupies the head of NumP, while in Chinese, grammatical classifiers occupy this head, as in (42a) and (42b), repeated from Chapter 3:

- (42) a. $[_{DP} D [_{NumP} \text{plural}]_{NUM} [_{NP} N]]$ → English count N
 b. $[_{DP} D [_{NumP} \text{Number}]_{NUM} [_{NP} N]]$ → Chinese count N
- (Wiltschko, 2007:18)

However, Wiltschko (2007) proposes that in Halkomelem NumP does not project, and the plural marker is modificational, as opposed to English, where NumP projects, as shown in (43a) and (43b), repeated from Chapter 3:

- (43) a. $[_{DP} D [_{NumP} \text{plural}]_{NUM} [_{NP} N]]$ → English
 b. $[_{DP} D [_{NP} N]]$ → Halkomelem
- (Wiltschko, 2007:19)

While there is no NumP in Halkomelem, the language uses classifiers as bound morphemes, which are lexical suffixes for counting, as in (44):

(44) *Halkomelem classifiers*

- a. -ále counting people
- b. -íws counting birds
- c. -íqw counting fish
- d. -álhp counting trees (belonging to one person)
- e. -òls counting fruit in a cluster
- f. -ó:llh counting young (in a litter)
- g. -ówelh counting canoes (belonging to one person)
- h. -ówes counting canoe paddles (in a single canoe)
- i. -á:wtxw counting houses (or buildings) of one person
- j. -eqel counting containers
- k. -ámeth' counting poles (tied together), sticks, ropes, threads
- l. -élwet for counting garments
- m. -áyiws for counting pants
- n. -mó:t for counting kinds or parts of things
- o. -álh for counting times

(Galloway, 1980:33-36)

In Halkomelem, however, there is no NumP projection; consequently, neither plural marking nor classifiers can occupy the head of NumP. Therefore, there is no co-occurrence restriction of the plural marker and classifiers, namely, they are not in complementary distribution, and the modificational plural marker can appear together with classifiers, as in (45), repeated from Chapter 3, and in (46):

(45) tsel kw'éts-l-exw lhxwále siyó:lexwe
1s.sg.s see-trans-3o three-cl old.people.pl
'I saw three old people.'

(46) a. iwólem lhq'áts-ále swóweles
play five-cl boy.pl
'Five boys were playing.'

b. tsel kw'étslexw yéysele slhelháli
1sg.s see-trans-3o two-cl woman.pl
'I saw two women.'

(Wiltschko, 2007:24-5)

In spite of the fact that Halkomelem has a detailed system of classifiers, classifiers in Halkomelem do not have the same function as Chinese classifiers.

In Chinese, where there is projection of NumP, there are obligatory classifiers occupying the head of NumP. In Halkomelem, however, there is no projection of NumP while the use of classifiers is optional, as in (47), repeated from Chapter 3, where classifiers are not required in the context of counting:

(47) a. tsel kw'éts-lexw isále sth'ím
1sg.s see-trans two berry/berry.pl
'I seen two berries.'

b. tsel kw'éts-lexw isále theqát

1sg.s see-trans two tree

'I seen two trees.'

(Wiltschko, 2007:23)

Another language that has classifiers occupying the head of NumP is Armenian. Although Chierchia (1998) argues that it is likely that in classifier languages there is no plural marking, Borer (2005) argues that both classifiers and number marking can have the role of individualizing nouns; nevertheless, they are in complementary distribution. Borer (2005) shows that in Armenian both plural marking and classifiers are present; nevertheless, they have no co-occurrence. The restriction of the co-occurrence of classifiers and the plural marker in Armenian can be viewed in the presence of NumP. This restriction follows the proposal by Wiltschko (2007) that when the plural marker and classifiers occupy the head of the functional category NumP, they cannot co-occur, namely, they are in complementary distribution, as seen in (48) by Borer (2005), repeated from Chapter 3:

(48) a. *Cardinal, no classifier, no plural*

yergu hovanoc uni-m

two umbrella have-1SG

'I have 2 umbrellas.'

b. *Cardinal, classifier, no plural*

yergu had hovanoc uni-m
two CL umbrella have-1SG
'I have 2 umbrellas.'

c. *Cardinal, no classifier, plural*⁵²

yergu hovanoc-ner uni-m
two umbrella-pl have-1SG
'I have 2 umbrellas.'

d. **Cardinal, classifier, plural*

*yergu had hovanoc-ner uni-m
two CL umbrella-PL have-1SG
'I have 2 umbrellas.'

(Borer, 2005:117-18)

However, Piriawiboon (2008) questions why sometimes neither plural marking nor classifiers occur, as in (48a), while they are in complementary distribution. As the structure of plural marking and classifiers in Armenian is to some extent similar to the structure of their counterparts in Persian, I raise the same question in Persian to investigate the NumP projection.

⁵² This combination is not possible in Persian because of the existence of the empty classifier in Persian.

Persian is another language that has a co-occurrence restriction of classifiers and plural marking. Example (49a) reveals that in Persian, a cardinal and a classifier can co-occur, while the classifier can be optional⁵³. However, example (49b) shows that plural marking can co-occur with a cardinal accompanying a classifier in a definite nominal phrase in informal language, but the plural marker is optional. Example (49c⁵⁴) shows that a cardinal can co-occur with a bare noun, yet it cannot co-occur with a bare plural, as in (49d):

(49) a. *bist (ta) sərbaz dar xiyaban bud-ænd.*

twenty (CL) soldier on street be-PAST.3PL

‘Twenty soldiers were on the street.’

b. *bist ta sərbaz-(ha) dar xiyaban bud-ænd.*

twenty CL soldier-(PL) on street be-PAST.3PL

‘The twenty soldiers were on the street.’

c. *bist sərbaz dar xiyaban bud-ænd.*

twenty soldier on street be-PAST.3PL

‘Twenty soldiers were on the street.’

d. **bist sərbaz-ha dar xiyaban bud-ænd.*

twenty soldier-PL on street be-PAST.3PL

⁵³ When there is presence of the classifier *ta*, the register is informal; however, in formal register the classifier is absent.

⁵⁴ This sentence is used in formal Persian because there is an absence of the classifier.

‘Twenty soldiers were on the street.’

Consequently, following Borer (2005) and Wiltschko (2007), I propose that in Persian, classifiers and plural marking are in complementary distribution. The presence of a classifier, as in (49a), and the absence of a classifier in (49c) show that cardinals in Persian co-occur with classifiers or empty classifiers. The co-occurrence restriction of a cardinal with plural marking, as in (49d), is because there is an empty classifier in this structure; therefore, plural marking cannot co-occur with either a classifier or an empty classifier. As a result, I propose that either plural marking or classifiers/empty classifiers, individualizing nouns, occupy the head of NumP in Persian, as in (50), adapted from Wiltschko (2007):

(50) a. [_{DP} D [_{CardP} [_{NumP} **[plural/classifier/Ø_{CL}]** NUM [_{NP} N]]] → Persian

The presence of a cardinal in a nominal phrase in Persian requires the presence of a classifier or an empty classifier, as in (51a). In Persian, as in English, NumP projects; however, in Persian, cardinals and plural marking cannot co-occur in a nominal phrase⁵⁵, as in (51b), though in English there is no restriction on the co-occurrence of cardinals and plural marking, as in (52):

⁵⁵ That there is a co-occurrence restriction between cardinals and plural marking in Persian is discussed by Ghaniabadi (2010). Referring to the economy constraint in (i), Ghaniabadi proposes that the feature [+pl] is inherently specified on the head of CardP; therefore, the spell-out of the plural marking, which has the feature [+pl], is rendered redundant by this feature.

(i) *Principle of Avoiding Redundant Plural Marking*

There is no more than one realization of [+pl] within the noun phrase.

(Ghaniabadi, 2010:148)

(51) a. se (ta) bošqab ruye miz æst.
three (CL) plate on table be-PAST.1SG

‘There are three plates on the table.’

b. * se bošqab-ha ruye miz æst.
three plate -PL on table be-PAST.1SG

(52) three radios

As discussed in Chapter 3, Ghomeshi (2003) argues that NumP does not project in Persian. She argued that in the case of bare singulars in direct object positions⁵⁶ if bare singulars are count nouns, coerced mass interpretation is not necessarily induced.

⁵⁶ Examples of bare plurals in direct object positions, repeated from Chapter 3, are as follows:

(ii) a. (mæn) diruz qæhve xord-æm.
I yesterday coffee drink.PAST-1SG
‘I drank coffee yesterday.’

b. (mæn) diruz gušt poxt-æm.
I yesterday meat cook.PAST-1SG
‘I cooked meat yesterday.’

c. (mæn) diruz ketab xund-æm.
I yesterday book read.PAST-1SG
‘I read books [lit. book] yesterday.’

d. (mæn) diruz šir did-æm.
I yesterday lion see.PAST-1SG
‘I saw lions [lit. lion] yesterday.’

(Ghomeshi, 2003:52)

In English, however, Ghomeshi (2003) discusses how coercion effects are present because NumP projects in English, as in (53a), (53b), and (53c), repeated from Chapter 3, showing the grammatical distinction of nouns as count and mass:

(53) *English*

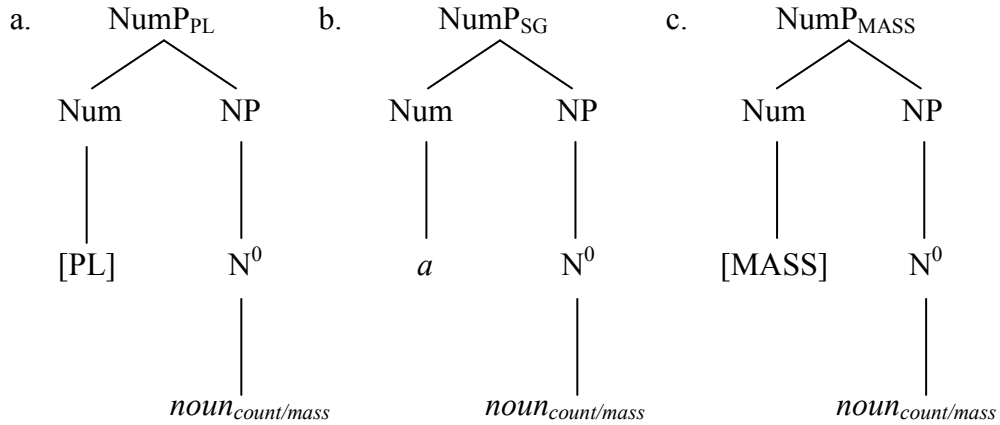

(Ghomeshi, 2003:54)

However, Ghomeshi (2003) argues that in Persian coercion effects are absent for non-referential nouns: as in (54), repeated from Chapter 3, which shows NumP is not projected in Persian.

(54) *Persian*

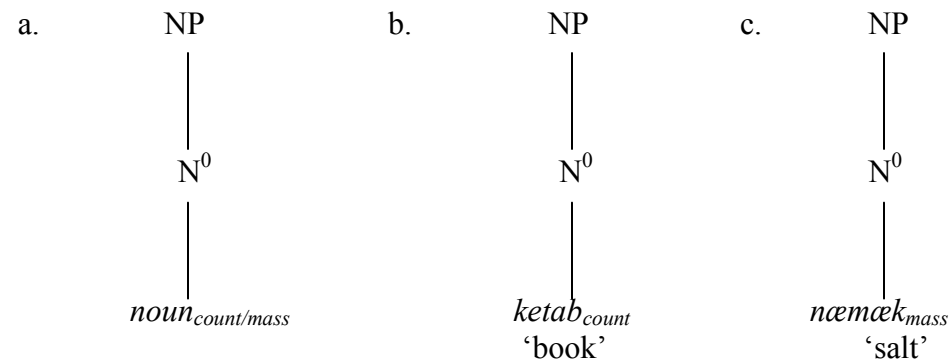

(Ghomeshi, 2003:54)

Ghameshi further discusses that the type of coercion effects in English is realized at the level of classifiers in Persian; however, she does not discuss about the position of classifiers in Persian, but she mentions that Persian classifier are like Chinese classifiers in making nouns countable. If in her system NumP does not project in Persian, I have supposed that classifiers project in in Persian, as shown in the following diagram, repeated from Chapter 3:

(55)

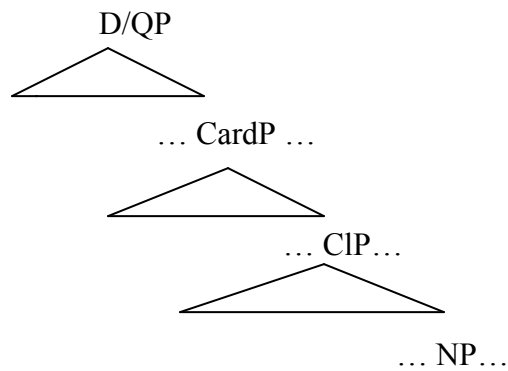

Ghameshi's (2003) claim that NumP in English is projected, is shown in (56a); however, she argues that NumP in Persian is not projected, as shown in (56b), repeated from Chapter 3, respectively:

(56) a.

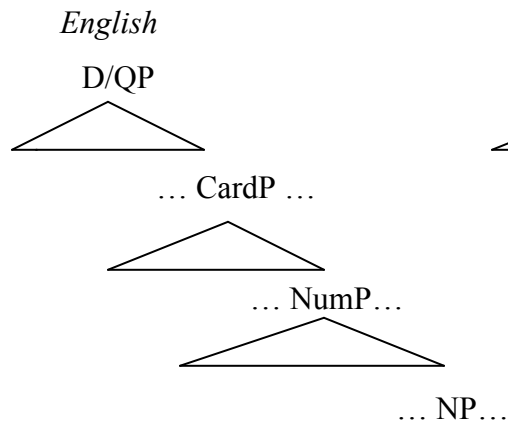

b. *Persian*

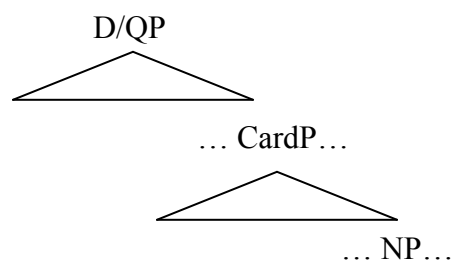

(Ghameshi, 2003:71)

Nevertheless, having argued that NumP is projected in Persian, I propose the diagram shown in (57), which is similar to the one proposed by Ghomeshi for English, shown in (56a). However, in Persian, either plural marking or classifiers occupy the head of NumP, whereas in English the head is occupied only by plural marking:

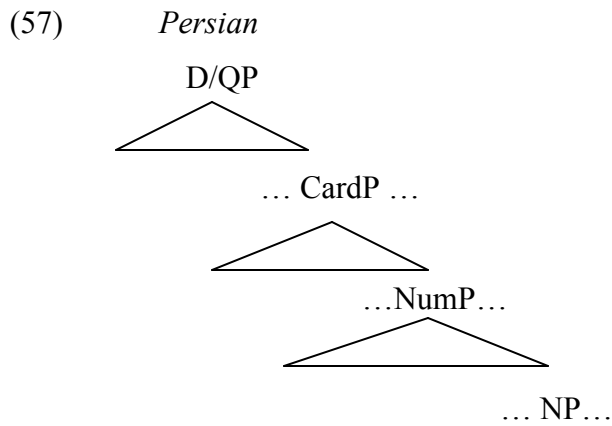

Another view of classifiers in Persian is from Gebhardt (2008), who points out that some languages, such as Persian, have co-occurrence of classifiers and plural marking, as shown in (58) for Persian, Paiwan, and Itzaj Maya. In Persian, the non-use of the plural marking in (58a) and (58c) induces an indefinite interpretation while the sentence in (58b) it receives a definite reading because of the presence of the plural marker. Examples (58d) from Paiwan and (58e) from Itzaj Maya indicate that in these languages there is co-occurrence of classifiers and plural marking:

- (58) a. do ta bačče sævaar-e otobus šod-ænd. Persian
 two CL child on-EZ bus got-3P

‘Two children got on the bus.’

b. do ta bačče-ha-ye bæradær-æm sævaar-e otobus šod-ænd.

two CL child-PL-EZ brother-my on-EZ bus got-3P

‘My brother’s two kids got on the bus.’

c. do ta bačče-ye bæradær-æm sævaar-e otobus šod-ænd.

two CL child-EZ brother-my on-EZ bus got-3P

‘Two of my brother’s kids got on the bus.’

(i.e. two of many of his kids got on the bus, the others did not.)

(Gebhardt, 2008:41)

d. ma-telu a vavayavavayan

Paiwan

CL-three A girl.Redup

‘three girls’

(Tang, 2004)

e. k’=tuul im-mejen paal-oo’-ej

Itzaj Maya

2=CL.Animate is.a-small child-PL-Top

‘my two small children’

(Hofling, 2000)

Therefore, Gebhardt (2008) assumes that, contra Borer, classifiers and plural marking do not have the same projection. Rather, plural marking implies a definite reading in classifier languages.

Following the discussion that classifiers and plural marking can co-occur in Persian, Gebhardt further shows that in (59) the presence of the plural marker *-ha* induces definiteness while in (60) a nominal phrase receives an indefinite reading if the plural marker is absent, regardless of whether or not there is a full classifier:

(59) do ta doxtær-ha

two CL girl-PL

‘the 2 girls/# ‘two girls’

(Gebhardt, 2008:46)

(60) do (ta) doxtær

2 (CL) girl

‘2 girls’/# ‘the 2 girls’

(Gebhardt, 2008:46)

In order to support the idea that the plural marker *-ha* involves definiteness, Gebhardt adopts Simpson’s (2005) raising analysis and Lyon’s (1999) DP analysis. However, provided that N-raising requires head-movement, movement skipping a c-commanding head is forbidden by the head-movement constraint (HMC) given in (61), as argued by Travis (1984):

(61) The head movement constraint

If Z^0 c-commands Y^0 which c-commands X^0 , then X^0 can't raise to Z^0 if Y^0 is occupied.

(Gebhardt, 2008:50)

Gebhardt argues that in example (63), if the plural marker *-ha* shows definiteness, there must be raising to D; however, the movement is blocked by the classifier and the numeral, as in (63), because of the HMC.

(62) se ta doxtær-ha

three CL girl-PL

'the three girls'

(Gebhardt, 2008:52)

(63) [DP[_{CardP} se [CLP ta [NumP doxtær-ha [NP *t*]]]]]

(Gebhardt, 2008:52)

In order to solve this problem, Gebhardt (2008) suggests the following while using probe-and-goal (Chomsky, 1998, 1999, and 2000):

The highest head in the nominal, D, searches for a c-commanded goal to agree with. A probe seeking a goal is not constrained in the same way as the HMC is

because the probe looks for the relevant feature, in this case definiteness, because relativized minimally holds. (p. 53)

Another view is from Ghaniabadi (2010) who argues that when there are numerals+classifiers combination in Persian in subject position, as in (64)⁵⁷, or in object position, as in (65), plural marker occur in indefinite noun phrases:

(64) se-tâ gonješk ru deraxt nešast-e=bud-an.

three-CLS sparrow on tree sat-PP=was-3PL

‘Three sparrows were sitting on the tree.’

(Ghaniabadi, 2010:121)

(65) se-tâ gonješk did-am.

three-CLS sparrow saw-1SG

‘I saw three sparrows.’

(Ghaniabadi, 2010:122)

Nevertheless, plural marking has optional co-occurrence with numerals+classifiers phrases, inducing definite reading. In example (66), the occurrence of the plural marker generates a reading of books as a whole, not a reading of a set consisting of individual items. Therefore, the plural marker has the reading of a universal quantifier. In example (67), the occurrence of the quantifier *har* ‘every’ triggers the same reading:

⁵⁷ This sentence can also have definite reading with a particular prosody.

(66) se-tâ ketâb(-â) ru-ye mize-e.

three-CLS book-PL on -EZ table-CL-is

‘The three books are on the table.’

(Ghaniabadi, 2010:122)

(67) har se-tâ ketâb(-â) ru-ye mize-e.

every three-CLS book-PL on -EZ table-CL-is

‘All the three books are on the table.’

(Ghaniabadi, 2010:122)

Ghaniabadi investigates why plural marking does not appear in indefinite noun phrases, such as (68a), which has a numeral+classifier, while in definite noun phrases, as in (68b), the plural marker occurs. He further questions the optional occurrence of the plural marker in definite noun phrases including numerals+classifiers, as in (68b):

(68) a. se-tâ ketâb(*-â)

three-CLS book(*-PL)

‘three books’

b. se-tâ ketâb(-â)

three-CLS book(-PL_{DEF})

‘the three books’

(Ghaniabadi, 2010:147)

Following Ghomeshi (2003), who argues that CardP includes noun phrases with numerals+classifiers combinations, Ghaniabadi presents the indefinite noun phrase structure including numerals+classifiers given in (69):

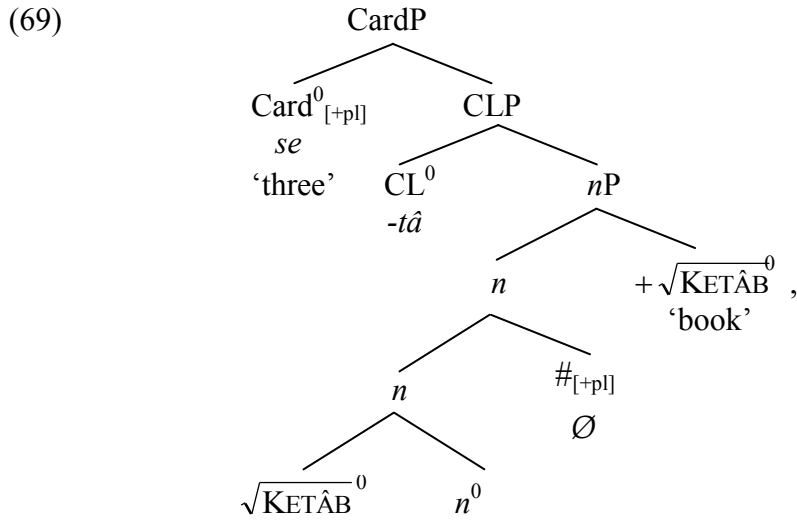

(Ghaniabadi, 2010:147)

As discussed before, in order to explain why plural marking is not allowed in indefinite nominal phrases having numerals+classifiers, Ghaniabadi proposes that the feature [+pl] is inherently specified on the head of CardP, as illustrated in (67); therefore, if there is another [+pl] feature, the feature of the plural marker, the spell-out of the redundant feature is prevented by the inherently specified [+pl] feature. This can be explained by the economy constraint, presented in footnote 55, repeated below as (70):

(70) *Principle of Avoiding Redundant Plural Marking*

There is no more than one realization of [+pl] within the noun phrase.

(Ghaniabadi, 2010:148)

To explain why plural marking occurs in definite noun phrases having numerals+classifiers, Ghaniabadi presents the structure in (71), which illustrates a definite *nP* as a complement of a *CardP*:

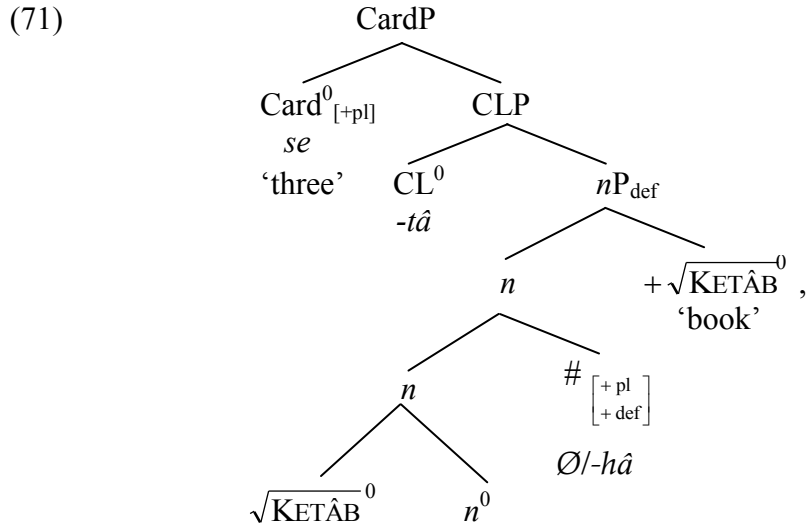

(Ghaniabadi, 2010:149)

As illustrated in (71), *-ha* contains both [+pl] and [+def] features; however, Ghaniabadi suggest that the feature [+def] is spelled out rather than [+pl].

In order to provide an answer to the question of why plural marking is optional in definite noun phrases having numerals+classifiers, Ghaniabadi proposes the following constraints through which economy considers the optionality of *-ha*:

- (72) (i) [+pl] must be phonologically realized.
 (ii) [+def] must be spelled out.
 (iii) Avoid redundancy in number marking.

(Ghaniabadi, 2010:150)

These constraints can also account for the ungrammaticality of plural marking appearing in indefinite noun phrases having numerals+classifiers. The co-occurrence of the plural marker and numerals+classifiers is disallowed by economy when noun phrases are indefinite; therefore, Ghaniabadi argues that constraint (i) is outranked by constraint (iii). The optionality of the plural marker in definite noun phrases is because constraints (ii) and (iii) are tied, namely, both are evenly economical.

I agree with both Gebhardt's and Ghaniabadi's proposals that the plural marker induces definiteness in a nominal phrase with a [Card + CL + N + PL] combination. I also agree with Ghaniabadi that in this combination, plural marking is optional. However, I disagree with part of their analysis as I argue that NumP projects in Persian, and the head of NumP is either occupied by classifiers or by plural marking; therefore, the co-occurrence of plural marking and a classifier in a definite noun phrase does not imply that both occupy the head of NumP. Rather, only the full classifier occupies the head of NumP. In addition, I propose that a classifier and plural marking can co-occur in definite nominal phrases in Persian, as in (73), on the condition that plural marking is not required for individualizing nouns. The plural marker, however, has a modificational role that induces definiteness.

(73) an do *(ta) ketab-(ha) ro xærid-i?

that two CL book-(PL) OM buy.PAST-2SG

'Did you buy those two books?'

When the plural marker occurs in a combination of [Card + CL + N + (PL)], as in (73), the use of the classifier is not optional because it has an individualizing role. Accordingly, I propose that in the context of definite nominal phrases, classifiers are not optional.

In sum, Persian is a classifier language in which a classifier can occur in an indefinite noun phrase combination of [Card + (CL) + N]. Classifiers in Persian have the function of individualizing nouns, as does plural marking. Moreover, plural marking and classifiers in Persian occupy the head of NumP; however, they are in complementary distribution. When a classifier is absent in a noun phrase having a combination of [Card + \emptyset_{CL} + N], the head of NumP is occupied by an empty classifier. Plural marking in Persian can optionally occur in a combination of [Card + CL+ N + (PL_{DEF})] if it has a modificational role that induces definiteness. However, in this combination, a classifier is always full⁵⁸.

4.5 Summary

Not only does plural marking individualize nouns in Persian, but Persian classifiers, like classifiers in Chinese, also individualize nouns. However, classifiers and plural marking in Persian are in complementary distribution in the context of counting; consequently, the head of NumP is either occupied by grammatical number or by grammatical classifiers.

That the plural marker cannot occur in an indefinite noun phrase having a combination of [Card + CL + N] or [Card + \emptyset_{CL} + N] shows the co-occurrence

⁵⁸ Further research needs to be done in order to find out why in such combinations classifiers are always full.

restriction of classifiers and plural marking. This restriction is because the head of NumP is occupied either by a classifier or by an empty classifier.

Persian plural marking can optionally occur in a definite noun phrase having a [Card + CL + N + (PL_{DEF})] combination; however, the plural marker does not occupy the head of NumP in this case. Rather, this head is occupied by a full classifier. As a result, the definite plural marker in this combination has a modificational role.

Chapter 5: Bare singulars/plurals in Persian

5.1. Introduction

In this chapter, I will argue that there is a relationship between bare singulars/plurals in predicative or argument positions and the projection/non-projection of NumP in Persian. The goal is to analyze the distribution of bare singulars/plurals in Persian in the framework of two parameters introduced by Schmitt and Munn (2000) and investigate their relationship to NumP. The underlying claim I will argue for is that one or both of these two morpho-syntactic parameters are required in order to license bare singulars/plurals in argument or predicative positions in Persian, as in Brazilian Portuguese, where the combination of these two parameters allows bare singulars in argument positions. One of these two parameters results in having split Num and Agr in Romance⁵⁹, contrasting with English, in which Num and Agr are not split. The other parameter allows a null determiner in Brazilian Portuguese.

What Schmitt and Munn (2000) argue with regard to the empty determiner parameter in Brazilian Portuguese, bare singulars being DPs with null Ds, is compatible with what Ghomeshi (2008) argues with respect to bare nouns in Persian when they are DPs. She argues that bare nouns in Persian are either kind-referring NPs or DPs with empty D⁰-heads. Following Vergnaud and Zubizarreta

⁵⁹ When Schmitt and Munn (2000) use the term ‘Romance’, they refer to French, Spanish, Portuguese, and Italian, but not any other Romance languages.

(1992)⁶⁰, I propose that Persian empty definite determiners can be expletive. When an empty definite determiner is expletive in Persian, a nominal expression receives a type reading; however, a token interpretation of an empty definite determiner in Persian implies that there is merely an empty definite determiner.

In the following section, I will discuss the distribution and interpretation of bare singulars/plurals in different syntactic positions in Persian. Next, I will present Schmitt and Munn's (2000) argument of how the two morpho-syntactic parameters, the Free Agr parameter and the empty determiner parameter, function in Brazilian Portuguese. After discussing each of the two parameters, I will demonstrate how Persian requires each in order to allow bare singulars/plurals. Moreover, I will present Ghomeshi's (2008) discussion of bare nouns in Persian, which is in accordance with Schmitt and Munn's (2000) discussion of the empty determiner parameter in argument positions in Brazilian Portuguese. Following that, I will present the discussion of the expletive definite determiner in Persian.

5.2 Distribution of bare singulars/plurals in Persian

Bare nouns can appear in different syntactic positions with different interpretations cross-linguistically. For instance, in Dutch, English, German, and Flemish (Oosterhof, 2004) bare plurals in subject and object positions behave differently from the point of view of N-to-D raising⁶¹. In Romanian, Dogaru (2005) assumes

⁶⁰ Vergnaud and Zubizarreta (1992) argue that in French, the definite determiner *le* can be an expletive from a denotational point of view.

⁶¹ Oosterhof (2004) argues that in Dutch, English, German, and Flemish bare plurals in object positions are not receiving kind reading while in subject positions they are kind-referring. Because subject positions are not lexically governed positions, D in these positions is not empty. Therefore,

the two parameters for bare nouns proposed by Schmitt and Munn (distinct Number and Agreement projection and null determiner)⁶² in order to interpret bare nouns in different syntactic positions. Tonciulescu (2009) discusses that in Hebrew bare singular being definite in subject and object positions can be kind-referring⁶³.

Persian bare singulars/plurals appear in different syntactic positions, such as subject and object positions as well as predicative positions. Persian bare singulars are allowed in predicative positions, as in (1a) and (2a), with plural interpretations:

(1) a. anha **moæ?llem** hæst-ænd.

they teacher be.PRES-3PL

‘They are teachers.’

b. u **moæ?llem** æst.

He/she teacher be.PRES-3SG

‘He/She is a teacher.’

there is N-to-D raising while kind-referring is induced. However, object positions are lexically governed. Hence, D can be empty, and an indefinite reading without N-to-D raising is received.

⁶² Bare singulars in Romanian occur in predicate positions because number feature is missing. In subject positions, bare singulars are not generally available. However in object positions bare singulars occur in Romanian. Therefore, Number is not projected, but only AgrP is projected.

⁶³ In subject positions in Hebrew, a kind or object reading depends on the selectional properties of predicates. If a verb is object-selecting, a bare noun in an object position receives a kind-interpretation. Also, the definite determiner plays a role in a kind-reading or an object-reading if verbs are object-selecting. The definite determiner in subject positions can introduce a singularity presupposition or a massifying function, while in an object position only a singularity presupposition can be introduced.

(2) a. *šoma ostad hæst-id*⁶⁴.

you professor be.PRES-2PL

‘You are professors.’

b. *to ostad hæst-i*.

you professor be.PRES-2SG

‘You are a professor.’

Persian allows bare singulars and plurals in argument positions, as in (3), and as in (4), repeated from Chapter 1, with different readings. As discussed in Chapters 1 and 2, bare plurals in object positions are very marked⁶⁵:

(3) a. *u hæz ruz name mi-nevis-æd*.

he/she every day letter DUR-write.PRES-3SG

‘He/She writes a letter/letters every day.’

b. *man name-ha nevešt-æm*.

I letter-PL write.PAST-1SG

‘I wrote all sorts of letters.’

⁶⁴ In formal register, in order to respect someone, the second person plural subject *šoma* ‘you’ with the plural verb is used while referring to a second person singular subject, as in (i):

(i) *šoma ostad hæst-id*.
you professor be.PRES-2PL
‘You are a professor.’

⁶⁵ Bare plurals in object positions have restricted usage. They carry a special kind of connotation, amazement or surprise; therefore, the sentence in (2a) carries the following connotation:
‘You can’t imagine how many sorts of letter I wrote.’

(4) a. **bæčče** karton dust=dar-æd.

child cartoon like=have.PRES-3SG

‘A/The child likes cartoons.’

b. **bæčče-ha** karton dust=dar-ænd.

child-PL cartoon like=have.PRES-3PL

‘(The) children like cartoons.’

In the following sections, I will describe different interpretations of bare singulars and bare plurals in subject, object, and predicative positions in Persian.

5.2.1 Persian bare singulars/plurals in subject positions

Bare singulars and bare plurals in Persian are allowed in subject positions. As there is no definite determiner in Persian, with the exception of the stressed *-e*⁶⁶ in colloquial speech, the interpretation a bare singular or a bare plural in a subject position receives depends on the context.

Examples of the different interpretations a bare singular can receive are provided in (5) and (6). In (5), *doxtær* ‘girl’ receives a kind-referring interpretation, whereas in (6), it has a definite reading in the second sentence because it refers to *yek doxtær* ‘one/a girl’ in the first sentence in (6):

⁶⁶ Ghemoshe (2003) discussed that the stressed *-e* or *-e*, if it is non-word-finally, is a suffix used to mark definiteness in colloquial Persian.

(5) **doxtær** be madær-æš næzdiktær æst.

girl to mother-POSS closer be.PRES-3SG

‘A girl (generally) is closer to her mother.’

kind

(6) dær xanevade-ye anha do færzænd æst, yek pesær va yek doxtær.

in family-EZ they two kid be.PRES-3SG one boy and one girl

doxtær be madær-æš næzdiktær æst.

girl to mother-POSS closer be.PRES-3SG

‘In their family, there are two kids, a boy and a girl. The girl is closer to her mother.’

definite

The interpretations of bare plurals in subject positions resemble the interpretations of bare singulars in these positions. If a bare singular with a kind reading in a subject position, like *doxtær* ‘girl’ in (5), becomes plural, it receives a kind reading, as in; similarly, if a bare singular with a definite interpretation in a subject position, like *doxtær* ‘girl’ in (6), becomes plural, the definite interpretation is preserved, as in (7) and (8) respectively:

(7) **doxtær-ha** be madær-ešan næzdiktær-ænd.

girl-PL to mother-POSS closer-be.PRES-3PL

‘Girls (generally) are closer to their mothers.’

kind

(8) *dær xanevade-ye anha čahar færzænd æst, do pesær va do*
 in family-EZ they four kid be.PRES-3SG two boy and two
doxtær. doxtær-ha be madær-ešan næzdiktær-ænd.
 girl girl-PL to mother-POSS closer-be.PRES-3PL

‘In their family, there are four kids, two boys and two girls. The girls are
 closer to their mother.’ *definite*

Accordingly, the bare singular *bæčče* ‘child’ in subject position in (9a),
 repeated from Chapter 1, and the bare plural *bæčče-ha* ‘children’ in subject position
 in (9b), repeated from Chapter 1, receive kind or definite readings depending on
 their interpretation in the context:

(9) a. **bæčče** karton dust=dar-ænd.

child cartoon like=have.PRES-3SG

‘A/The child likes cartoons.’

kind/definite

b. **bæčče-ha** karton dust=dar-ænd.

child-PL cartoon like=have.PRES-3PL

‘(The) Children like cartoons.’

kind/definite

However, in examples (10a) and (10b), the bare singulars/plurals receive only
 definite readings:

(10) a. **zæn** dašt kar=mi-kærd. **mærd** dašt
 woman had.PROG-3SG work=DUR-do.PAST-3SG. man had.PROG-3SG
 qæza mi-xord.
 food DUR-eat.PAST-3SG.
 ‘The woman was working. The man was eating food.’ *definite*

b. **zæn-ha** daštænd kar=mi-kærd-ænd. **mærd-ha**
 woman-PL had.PROG-3PL work=DUR-do.PAST-3SG. man-PL
 dašt-ænd qæza mi-xord-ænd.
 had.PROG-3PL food DUR-eat.PAST-3PL
 ‘The women were working. The men were eating food.’ *definite*

If a bare singular or plural in subject position is followed by the indefinite enclitic *-i/yi*⁶⁷, it receives an indefinite reading, as in (11) and (12):

(11) hæR ruz **sæg-i** az inja ræd=mi-šæv-æd.
 every day dog-IND from here pass=DUR-become.PRES-3SG
 ‘A dog passes here everyday.’ *indefinite*

(12) hæR ruz **sæg-ha-yi**⁶⁸ az inja ræd=mi-šæv-ænd.
 every day dog-PL-IND from here pass=DUR-become.PRES-3SG
 ‘Some dogs pass here everyday.’ *indefinite*

⁶⁷ Ghomeshi (2003) argues that the indefinite enclitic *-i* in Persian heads a QP.

⁶⁸ When the enclitic *-i* follows a vowel sound, it sounds as *-yi*.

In sum, bare singulars and bare plurals in subject positions receive kind or definite interpretations. If the indefinite enclitic *-i/-yi* follows them, indefinite interpretations are received.

5.2.2 Persian bare singulars/plurals in object positions

Bare singulars and bare plurals in Persian are allowed in object positions; however, they can receive different interpretations. The bare singular *xa:ne* ‘house’ in (13a) is kind-referring while the bare plural *xa:ne-ha* ‘houses’ in (13b) has the interpretation of different kinds of houses. Ghomeshi (2008) argues that plural marking on a kind-referring bare singular induces a taxonomic reading such as more than one *kind/sort*.

(13) a. **xa:ne** did-æm.

house see.PAST-1SG

‘I saw a house/houses.’

kind

b. **xa:ne-ha** did-æm.

house-PL see.PAST-1SG

‘I saw different kinds/sorts of houses.’

different kinds

Ghomeshi (2008) argued that kind-referring bare singular nouns as complements to verbs, as in (14a), are number-neutral. However, as mentioned before for the other examples of bare plurals in object positions, the usage of such

bare plurals, as in (13b) and (14b), is very restricted. This type of bare plurals in Persian is very marked and carries a particular connotation⁶⁹:

(14) a. ali ketâb xunde.

Ali book read.PART-3SG

‘Ali has read books.’

b. ali ketâb-a xunde.

Ali book-PL read.PART-3SG

‘Ali has read all sorts of books.’ or ‘Ali has read a lot.’

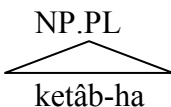
c. 

(Ghameshi, 2008:94-95)

Bare singulars followed by the enclitic *-i* induce indefinite interpretations in formal Persian, as in (15a). In informal Persian, the cardinal *yek/ye* ‘one’ can be used instead of the enclitic *-i*, as in (15b), or it can accompany it, as in (15c), when there is a singular noun with an indefinite interpretation:

(15) a. **name-yi** nevešt-æm.

letter-IND write.PAST-1SG

⁶⁹ Sentences (13b) and (14b) have the following connotations, respectively:

(i) ‘You can’t imagine how many sorts of houses I saw.’

(ii) ‘You can’t imagine how many sorts of letters Ali has read.’

‘I wrote a letter.’

indefinite

b. **ye name** nevešt-æm.

one letter write.PAST-1SG

‘I wrote a letter.’

indefinite

c. **ye name(-yi)** nevešt-æm.

one letter(-IND) write.PAST-1SG

‘I wrote a letter.’

indefinite

Bare plurals in informal Persian are used with the classifier *ta*, as in (16a), and in informal Persian with this classifier, as in (16b) inducing indefinite reading:

(16) a. čænd ta **name** nevešt-æm.

several CL letter write.PAST-1SG

‘I wrote some letters.’

indefinite

b. čænd **name** nevešt-æm.

several letter write.PAST-1SG

‘I wrote some letters.’

indefinite

All bare singulars and bare plurals in object positions, as in (13a) and (13b), as well as indefinite singulars in object positions, as in (15a), can be followed by *ra*⁷⁰, with different interpretations, as in (17), and as in (18), which is used in formal Persian. Ghomeshi (2008) identified *ra*⁷¹ as the direct object marker in Persian. When *ra* marks a bare singular or a bare plural in an object position, as in (17a) and (17b), a definite reading is induced; nevertheless, a *ra*-marked indefinite singular or plural, as in (18), does not receive a definite reading:

(17) a. **xa:ne-ra** did-æm.

house-OM see.PAST-1SG

‘I saw the house.’

definite

b. **xa:ne-ha-ra** did-æm.

house-PL-OM see.PAST-1SG

‘I saw the houses.’

definite

(18) **name-yi-ra** nevešt-æm.

letter-IND-OM write.PAST-1SG

‘I wrote a (specific) letter.’

indefinite

⁷⁰ The direct object marker *ra* has received different overviews (see Dabir-Moghadam, 1992; Karimi, 2003, 1989, 1990; Ganjavi, 2007; Ghomeshi, 1997, 2003, 2008, among others) in the literature.

⁷¹ Ghomeshi (1997, 2003, 2008) also identified *ra* as a case marker heading a Kase Phrase. In spoken Persian, *-ra* is reduced to *-ro* after vowels or to *-o* after consonants.

The syntactic characteristics of the object marker *-ra* are controversial in the literature. Ganjavi (2007) argues that *-ra* follows direct objects that are DPs. Such objects can be modified by determiners, as in (19). They can also be proper nouns, as in (20), or pronouns, as in (21):

(19) târâ un ketâb - *(o) xarid-Ø

Tara that book - RÂ bought-3SG

‘Tara bought that book.’

(Ganjavi, 2007:109)

(20) (mâ) mehdi*(ro) be tinâ mo’arefi : kard-im

We Mehdi-RÂ to Tina introduction : did-1PL

‘We introduced Mehdi to Tina.’

(Ganjavi, 2007:109)

(21) rusteen unhâ -*(o) ru miz gozâsht-Ø

Rusteen them -RÂ on table put-3SG

‘Rusteen put them on the table.’

(Ganjavi, 2007:110)

Some examples of other DPs in direct object positions followed by *ra* are shown in (22) through (26):

(22) Reciprocals

peyvand -o amin hamdigar- *(o) na-shenâx-tan

Peyvand and Amin each other - RÂ NEG-recognized-3PL

‘Peyvand and Amin didn’t recognize each other.’

(Ganjavi, 2007:110)

(23) Reflexives

marjân xod-esh - *(o) kosht-Ø

Marjan self-3SG- RÂ killed-3SG

‘Marjan killed herself.’

(Ganjavi, 2007:110)

(24) Wh-Words

(to) ki - *(ro) did-i?

you who-RÂ saw-2SG

‘Who did you see?’

(Ganjavi, 2007:110)

(25) Possessive DP’s

târâ ketâb-hâ-ye rezâ-*(ro) pare: kard-Ø

tara book-PL-EZ Reza - RÂ torn: did-3SG

‘Tara tore Reza’s books.’

(Ganjavi, 2007:111)

(26) *Quantifiers*

maryam hame-ye lebâs-hâ - *(ro) baxshid-Ø

Maryam all-EZ dress-PL - RÂ gave away-3SG

‘Maryam gave away all the clothes.’

(Ganjavi, 2007:111)

Ganjavi (2007) also argued that *ra*-marked DPs in direct object positions are referential, as in (27). The referential pronoun *un* ‘that’ in (27) refers back to the DP *ketab(-e akâsi)* ‘(photography) book’ while in (28) the referential pronoun *un* ‘that’ cannot refer back to *ketab(-e akâsi)* ‘(photography) book’ as it is a non-referential object:

(27) hamid ketâb(-e akâsi)-ro xarid-Ø

Hamid book-EZ photography-RÂ bought-3SG

va un-o be parniyan -o parin dâd-Ø

& that-RÂ to Parniyan & Parin gave-3SG

‘Hamid bought that (photography) book and gave it to Parniyan and Parin.’

(Ganjavi, 2007:112)

(28) * hamid ketâb(-e akâsi) xarid-Ø

Hamid book-EZ photography bought-3SG

va un-o be parniyan -o parin dâd-Ø

& that-RÂ to Parniyan & Parin gave-3SG

‘Hamid (photography) book-bought and gave it to Parniyan and Parin.’

(Ganjavi, 2007:112)

Karimi (2003) argues that *ra* always follows a specific DP, whether definite or indefinite. Karimi (2003) identifies nonspecific DPs, like *mâhi* ‘fish’ in (29), denoting no discourse referent, as *kind-level*; nevertheless, a nonspecific DP that is modified by a numeral⁷², like *ye âpârtêmân* ‘an apartment’ in (30), is *existential*:

- (29) Kimea tunest mâhi be-gir-e *un xeyli châgh-e
K managed fish subj-catch-3sg it very fat-be3sg
‘Kimea managed to catch fish.’ ‘It is very fat.’
(Karimi, 1999b)

- (30) Kimea tunest ye âpârtêmân peydâ kon-e un xeyli ghashang-e
K managed an apartment find do-3sg it very pretty-be 3sg
‘Kimea managed to find an apartment.’ ‘It is very pretty.’
(Karimi, 1999b)

Comparing and contrasting Persian and English, Karimi (2003) shows that kind-level and existential interpretations are received in different structures in these two languages. In Persian, bare DPs, as in (29), denote kind-level, but nonspecific indefinites, as in (30), denote existential reading. In English, however, nonspecific

⁷² The ‘numeral’ mentioned, according to Karimi (2003), means the cardinal *yek/ye* ‘one’, which is an alternative to the indefinite enclitic *-i*. It can also co-occur with *-i*.

(34) a. Sīrka **shīr rā** mi-burrad.

vinegar milk OM DUR-curdle-3SG

‘Vinegar curdles milk.’

(Dabir-Moghaddam, 1992:557)

b. mī-dānid chi-tawr **gūsfand rā** mi-kushand?

DUR-know.2PL how sheep OM DUR-kill.3PL

‘Do you know how a sheep is killed?’

(Dabir-Moghaddam⁷³, 1992:557)

(35) xod-æt ke **mærd-ha-ra** mi-šenasi.

self-2SG.CL FOC man-PL-OM DUR-know-2SG

‘You yourself know men.’

[*Like Water for Chocolate*, p. 130, by Laura Esquivel,

translated by Maryam Bayat, in Ghomeshi, 2003:51]

(36) reza **film-ha-ye farsi ro** xeili dust=dare.

Reza movie-PL-EZ Persian OM very like-have.PRES-3SG

‘Reza likes Persian movies very much.’

⁷³ Ghomeshi (2003) quotes these examples from Dabir-Moghaddam (1992), who quotes them from Phillott (1919:455,459). The pronunciation of these examples shows that they are different from that of standard Persian. However, Ghomeshi (2003) only changed the glosses to conform to her gloss system. She also mentions that sentence (33b) is not passive; therefore, a better translation would be as: ‘Do you know how they kill sheep?’

Also, objects of kind-selecting verbs (see Tonciulescu⁷⁴, 2009 for kind-selecting predicates in Hebrew), such as *extera?-kærdæn* ‘to invent’, *xæŋq-kærdæn* ‘to create’, and *kæšf-kærdæn* ‘to discover’, are followed by the object marker *-ra*, as in (37a), (38a), and (39a). It is worth mentioning that the presence of the object marker *-ra* is necessary in these structures; otherwise, they will be malformed, as in (37b), (38b), and (39b):

(37) a. *bæradær-an-e rayt hævapeima-ra extera?=kærd-ænd.*

brother-PL-EZ Wright airplane-OM invent=do.PAST-3PL

‘The Wright brothers invented the airplane.’

b. **bæradær-an-e rayt hævapeima extera?=kærd-ænd.*

brother-PL-EZ Wright airplane invent=do.PAST-3PL

(38) a. *xodavænd ensan-ra xæŋq=kærd.*

God mankind-OM create=do.PAST-3SG

‘God created mankind.’

⁷⁴ Tonciulescu (2009) states that in Hebrew both bare and definite singular nouns in object positions of kind-selecting predicates receive kind-interpretations. Kind-selecting predicates in Hebrew are predicates such as *create* and *invent*. Consequently, a kind-reading can be obtained with or without the presence of the definite determiner, as in (i):

(i) *Bell himči (et ha-)telefon.* √kind:#obj
 Bell invented (ACC the-)telephone
 ‘Bell invented the telephone.’

a) Kind-reading: it is this type of x that was invented.

b) No object-reading.

(Tonciulescu, 2009:16)

b. *xodavænd **ensan** xæŋq=kærd.
 God mankind create=do.PAST-3SG

(39) a. razi **alkol-ra** kæšf=kærd.
 Razi alcohol-OM discover=do.PAST-3SG
 ‘Razi discovered alcohol.’

b. *razi **alkol** kæšf=kærd.
 Razi alcohol discover=do.PAST-3SG

While direct objects like generic nouns, as in (34), (35), and (36), or objects of kind-selecting verbs, as in (37), (38), and (39), are all *ra*-marked, they do not receive definite readings; therefore, they can be distinguished from singular/plural *ra*-marked nouns receiving definite readings. This difference will be elaborated upon in §5.3.2.1.

Karimi (2003c) also presents a summary of specificity in the following diagram:

(40)

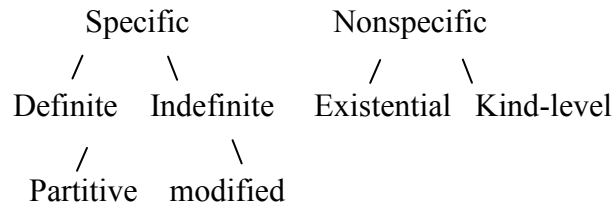

(Karimi, 2003c:12)

However, Ghomeshi⁷⁵ (1997), following Travis and Lamontagne (1992) discussing the Kase Phrase (KP), argued that *ra* is a phrasal affix that heads a Kase Phrase. She proposed that *ra* is a Kase-head and selects a DP. The indefinite determiner *-i* and the null definite determiner (see Ghomeshi, 2008) are both D-heads⁷⁶, as shown in (41a) and (41b). However, the difference between the indefinite determiner and the null definite determiner is that the former is not a case-assigner because it cannot license a possessor, whereas the latter can assign a case because in its specifier it can license a possessor. Also, the affix *ra* appears with pronouns and proper names that also project DPs, as shown in (41c):

(41) (a)

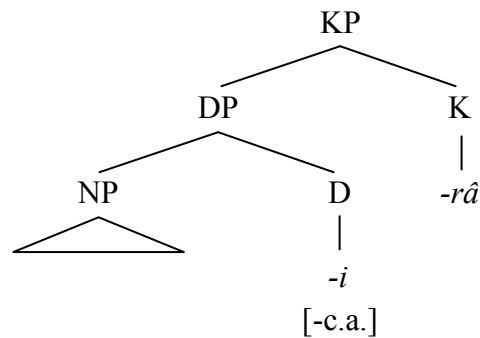

(Ghomeshi, 1997:136)

⁷⁵ Ghomeshi (1997) elaborated the specificity definition by Karimi (1989, 1990) as follows:

Definite (Specific)	Indefinite Specific (Referential)	Indefinite Non-specific (Existential/Quantificational)
- particular referent	- particular	- some referent but unfamiliar
- known to speaker	- known to speaker	
- presupposed to be known to hearer	- not presupposed to be known to hearer	

Ghomeshi (1997) argued that based on this definition, if there is a particular referent in the speaker's mind, a specific reading of the noun phrase is received. However, if this referent is presupposed to be known to the hearer, it is definite specific, but if it is not presupposed to be known to the hearer, it is indefinite specific. If the speaker and the hearer both have a referent that is unfamiliar, the noun phrase is indefinite nonspecific.

⁷⁶ Ghomesji (2003) discussed that the enclitic *-i* heads a QP.

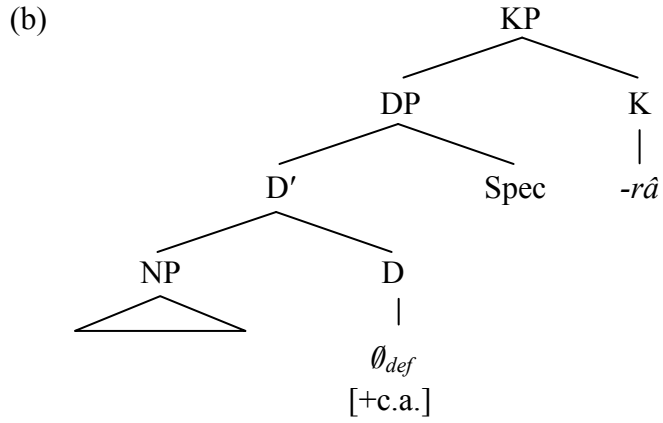

(Ghameshi, 1997:136)

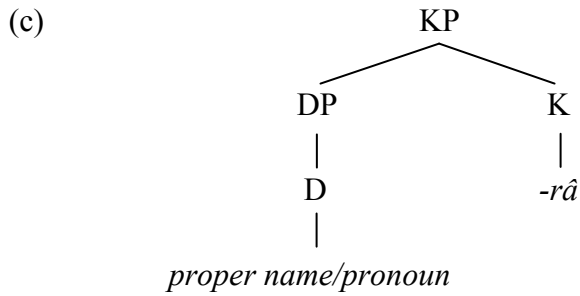

(Ghameshi, 1997:137)

Ghameshi (2008) illustrated the syntactic position of *-ra* as a case marker heading a Kase Phrase, which follows a plural noun in an object position, as in (42):

(42) a. ali **ketâb-â-ro** xunde.

Ali book-PL-OM read.PART.3SG

‘Ali has read the books.’

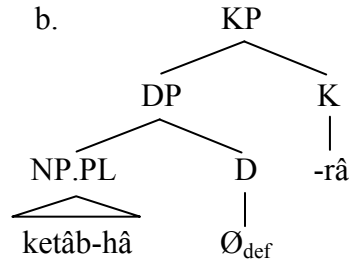

(Ghomeshi, 2008:94)

To summarize, I show different interpretations of Persian bare singulars and plurals in object positions in examples (43a) to (43j). A bare singular in an object position induces a kind reading, as in (43a), while a bare plural in an object position receives an interpretation of ‘all sorts of’, as in (43b). Bare plurals in object positions are very marked as they carry a special connotation⁷⁷. When the enclitic *-i* follows a bare singular in a direct object position⁷⁸, as in (43c), or when the cardinal *yek* ‘one’ is added to a bare singular⁷⁹, as in (43d), it has an indefinite interpretation.

In examples (43e) to (43f), direct objects are followed by the object marker *ra*. When *ra* follows a bare singular or a bare plural, a definite interpretation is received, as in (43e) and (43f). The object marker *ra* can also follow indefinite singulars with the indefinite reading retained, as shown in (43g), or following Karimi (2003) a specific indefinite reading is induced. Generic singulars/plurals

⁷⁷ Bare plurals in object positions carry a connotation of amazement or surprise. Therefore, the connotation of sentence (43b) is:

‘You can’t imagine how many sorts of notebooks he/she bought.’

⁷⁸ Bare singulars followed by the enclitic *-i* in direct object positions are very formal.

⁷⁹ The cardinal *yek* ‘one’ followed by a bare singular is used more in colloquial/informal Persian.

and objects of kind-selecting verbs are also followed by *ra*, inducing generic or kind interpretations, as in (43h), (43i), and (43j):

(43) a. u **dæftær** xærid.

he/she notebook buy.PAST-3SG

‘He/She bought a notebook/ notebooks.’

kind

b. u **dæftær-ha** xærid.

he/she notebook-PL buy.PAST-3SG

‘He/She bought all sorts of notebooks.’

all sorts of

c. u **dæftær-i** xærid.

he/she notebook-IND buy.PAST-3SG

‘He/She bought a notebook.’

indefinite

d. u **yek dæftær-(i)** xærid.

he/she one notebook-IND buy.PAST-3SG

‘He/She bought a notebook.’

indefinite

e. u **dæftær ra** xærid.

he/she notebook OM buy.PAST-3SG

‘He/She bought the notebook.’

definite

f. u **dæftær-ha ra** xærid.

he/she book-PL OM buy.PAST-3SG

‘He/She bought the notebooks.’

definite

g. u **dæftær-i** **ra** xærid.

he/she notebook-IND OM buy.PAST-3SG

‘He/She bought a notebook.’

(specific) indefinite

h. u mæ?mulæn **šir ra** mi-jušan-æd.

he/she usually milk OM DUR.boil.PRES-3SG

‘He/She usually boils milk.’

generic

i. u mæ?mulæn **ketab-ha ra** xub negæh=ne-mi-dar-æd.

he/she usually book-PL OM well keep=NEG-DUR.have.PRES-3SG

‘He/She usually does not keep books well.’

generic

j. bel **telefon ra** extera?=kærd.

Bell telephone OM invent=do.PAST-3SG

‘Bell invented the telephone.’

kind

In sum, bare singulars in object positions have a kind interpretation and bare plurals in these positions have the interpretation of different kinds/sorts. When the enclitic *-i* follows a bare singular or a bare plural, an indefinite reading is received;

when the object marker *ra* follows this combination, the indefinite reading is retained. However, when *ra* follows bare singulars/bare plurals, a definite interpretation is induced. Moreover, generic/kind bare singulars/plurals followed by the object marker *ra* receive generic/kind interpretations.

5.2.3 Persian bare singulars/plurals in predicative positions

Bare singulars in Persian occur in predicative positions, as in (1a) and (2a) repeated here as (44a) and (44b):

(44) a. *anha moæ?llem hæst-ænd.*

they teacher be.PRES-3PL

‘They are teachers.’

b. *šoma ostad hæst-id.*

you professor be.PRES-2PL

‘You are professors.’

However, bare plurals in Persian do not occur in predicative positions to induce indefiniteness, as shown in (45a) and (45b)⁸⁰:

⁸⁰ Sentences (45a) and (45b) can be grammatical if they induce definite readings, as in (i) and (ii), respectively:

(i) *anha moæ?llem-ha hæst-ænd.*
 they teacher-PL be.PRES-3PL
 ‘They are the teachers.’

(i) *šoma ostad-ha hæst-id.*
 you professor-PL be.PRES-2PL

(45) a. *anha **moæ?llem-ha** hæst-ænd.
they teacher-PL be.PRES-3PL

b. *šoma **ostad-ha** hæst-id.
you professor-PL be.PRES-2PL

In sum, bare singulars in Persian occur in predicative positions, but bare plurals in predicative positions in Persian are not allowed.

In the next section, I will discuss Schmitt and Munn's (2000) argument that two morpho-syntactic parameters make the occurrence of bare singulars possible in Brazilian Portuguese and some other languages.

5.3 The two morpho-syntactic parameters and bare nouns

Based on Borer's (1983) work, Schmitt and Munn (2000) argued that parameters belong to lexical items, particularly functional heads, rather than a binary switch. In the following sections, I will show how Schmitt and Munn (2000) argued that the two morpho-syntactic parameters, 'the Free Agr' and 'the empty determiner', are allowed in Brazilian Portuguese. Following Schmitt and Munn (2000), I will argue that these two morpho-syntactic parameters are allowed in Persian.

5.3.1 The Free Agr parameter in English and Romance

Following Bobaljik (1995), Schmitt and Munn (2000) argue that the projections of Tense and Agreement can either have a single 'fused' head or separate syntactic

'You are the professors.'

heads in different languages. They also argue that, following Chomsky (1995), the Free Agr parameter encodes whether there is merging of interpretable and uninterpretable features in the same head. If T, which is interpretable, and Agr, which is uninterpretable, are fused in a language, there is a clausal projection as in (46a). However, if T and Agr are not fused in a language, the clausal projection is as in (46b). English, in which T and Agr do not morphologically co-occur, has (46a) as its clausal representation, yet Romance, in which T and Agr do morphologically co-occur, has (46b) as its clausal representation:

(46) a.

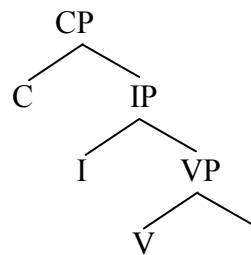

b.

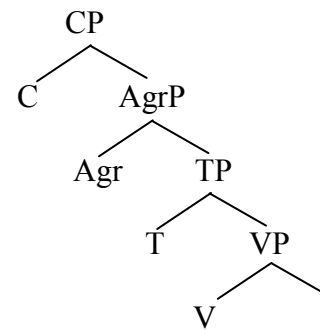

(Schmitt & Munn, 2000:30)

Schmitt and Munn (2000) show how English and Romance differ in the nominal domain in applying the Free Agr parameter. Within NPs in English there is no agreement except with demonstratives, English has fused Agr, and DPs maximally have the representation shown in (47a). However, in Romance, gender and agreement both exist in noun phrases, and DPs have the representation shown in (47b):

(47)a.

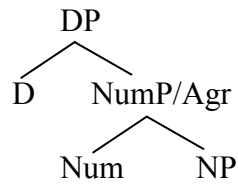

English

b.

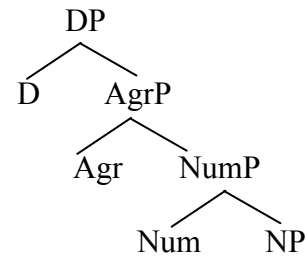

Romance

(Schmitt & Munn, 2000:30)

5.3.1.1 Lack of number in predicative positions in Romance

Schmitt and Munn (2000) argued that the Free Agr parameter results in having independent functions of T/Agr heads or Num/Agr heads. Interpretable and uninterpretable features are differentiated by Agr and Num; therefore, the Num feature can be missing on the condition that it is not needed in a position. This can be observed in predicative positions, where there is no need to have interpretable number because the predication subjects bear the feature of the interpretable number. As a result, bare singular predicates can exist in languages that have free Num/Agr, such as Romance, whereas in English, which does not have free Num/Agr, bare singulars are not allowed in predicative positions.

Schmitt and Munn (2000), following Anscombe (1987), showed lack of number in predicative positions in French and Spanish in a construction called *reprise-commentaire*. Examples (48) and (49) in French and Spanish, respectively, show that lack of number in predicative positions is allowed in these languages, but this is not allowed in English, where there is a bare appositive relative, as in (50a):

(48) Max a acheté une Ferrari, voiture qui lui coûte les yeux de la tête.
 Max has bought a Ferrari, car which to-him cost the eyes from the head
 (Schmitt & Munn, 2000:32)

(49) Max se compro un Ferrari, auto que le costo una fortuna.
 Max SE bought a Ferrari car that to-him cost a fortune
 Max bought a Ferrari, a car that cost him a fortune.
 (Schmitt & Munn, 2000:32)

(50) a. *Max bought a Ferrari, car that cost him a fortune.
 b. Max bought a Ferrari, a car that cost him a fortune.
 (Schmitt & Munn, 2000:32)

Example (48) shows that although Agr is present in the predicate, having *voiture* ‘car’ as its head, Num is not present, as shown in (51a). In example (50b) in English, Num is lexicalized as *a*, the indefinite article. The structure in (51b) shows the fused Num and Agr in English:

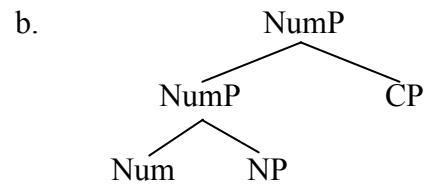
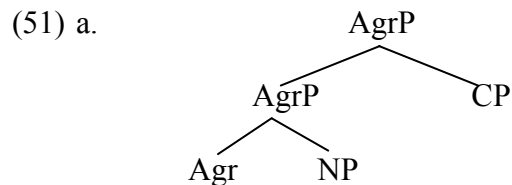

(Schmitt & Munn, 2000:33)

Schmitt and Munn (2000) also compare and contrast post copular predicates in Romance, which allows bare singulars, and English, which does not allow bare singulars in such positions, as in (52) and (53), respectively:

(52) a. Jean est médecin. (French)

b. Juan es médico. (Spanish)

J. is doctor

John is a doctor.

(Schmitt & Munn, 2000:22)

(53) *John is doctor.

(Schmitt & Munn, 2000:22)

Another predicative construction in which bare singulars are allowed in Romance is the *as*-construction, as in (54a) and (54b). In English, however, bare singular count nouns are not allowed in this construction, as shown in (55):

(54) a. Personne ne nous/le pourra prendre comme témoin. (French)

Nobody NE us/him can.FUT take as witness

b. Nadie podrá usarnos/usarlo como testigo. (Spanish)

Nobody can.FUT use-us/use-him as witness

Nobody will be able to use us/him as witnesses/a witness.

(Schmitt & Munn, 2000: 25)

- (55) a. *Nobody will be able to use us as witness.
 b. *Nobody will be able to use him as witness.
 c. Nobody will be able to use us as witnesses.
 d. Nobody will be able to use him as a witness.

(Schmitt & Munn, 2000: 26)

Following Schmitt and Munn (2000), I will argue in the next section that bare singulars are allowed in predicative positions in Persian because of the Free Agr parameter.

5.3.1.2 Lack of number in predicative positions in Persian

In Persian, as in Romance, bare singulars are allowed in predicative positions, as shown in (56a) and (57a). Although the subjects of the predicates in (56a) and (57a) are plural, the bare singulars, *danešju* ‘student’ and *pæræstar* ‘nurse’, in predicative positions show no plural agreement. Therefore, Agr is present but without Num. Consequently, because of the Free Agr parameter in Persian, the interpretable Num is absent in predicative positions. Examples (56b) and (57b) show that the presence of the plural marker is not allowed in predicative positions:

- (56) a. ma **danešju** hæst-im.
 we student be.PRES-1PL
 ‘We are students.’

b. *ma **danešju-ha** hæst-im.
we student-PL be.PRES-1PL

(57) a. šoma **pæræstar** bud-id.
you nurse be.PAST-2PL
'You were nurses.'

b. * šoma **pæræstar-ha** bud-id.
you nurse-PL be.PAST-2PL

Another construction in which bare singulars are allowed in Persian is the predicative *as*-construction, which behaves in the same manner as the *as*-construction in Romance does. Examples (58a) and (59a) show that Num is absent in the subjects of the predications *bazigær* 'actor' and *xæbærnegar* 'journalist.' As a result, the presence of the plural marker in Persian is not allowed in the subjects of predications in *as*-constructions, as shown in (58b) and (59b):

(58) a. æz anha/u beonvan-e **bazigær** estefade=kærd-ænd.
from them/him/her as-EZ actor use=do.PRES-3PL
'They used them/him (her) as actors/an actor.'

b. *æz anha beonvan-e **bazigær-ha** estefade=kærd-ænd.
from them as-EZ actor-PL use=do.PRES-3PL

(59) a. ma/mæn ra beonvan-e **xæbærnegar** estexdam=mi-kon-ænd.
 we/I OM as-EZ journalist employment=DUR-do.PRES-3PL
 ‘They employ me/us as journalists/a journalist.’

b. *ma ra beonvan-e **xæbærnegar-ha** estexdam=mi-kon-ænd.
 we OM as-EZ journalist-PL employment=DUR-do.PRES-3PL

In sum, the absence of Num in predicative positions in Persian is a result of the Free Agr parameter. In the following section, I will discuss how Schmitt and Munn (2000) argued that this parameter allows bare singulars in argument positions in Brazilian Portuguese.

5.3.1.3 Lack of number in bare singular arguments in Brazilian Portuguese

In this section, the presence of bare singulars in argument positions in Brazilian Portuguese is shown to be a result of split Num/Agr. Schmitt and Munn (2000) showed how Brazilian Portuguese lacks number in argument positions. Bare singulars in Brazilian Portuguese can have either singular or plural references, as in (60), with existential and generic readings:

(60) a. Tem criança na sala. E **ela** está/ **elas** estão ouvindo.

*Has child in-the room. And **she** is/ **they** are listening*

There is a child/are children in the room. And she/they are listening.

b. Eu vi criança na sala. E **ela** estava / **elas** estavam ouvindo.

I saw child in-the room. And she was/ they were listening.

I saw a child/children in the room. And she was/they were listening.

(Schmitt & Munn, 2000:37)

A bare plural in Brazilian Portuguese cannot have a singular pronoun as its reference, as in (61):

(61) a. Tem crianças na sala. E ***ela** está / **elas** estão ouvindo.

Have children in-the room. And she is/ they are listening

There are children in the room. And *she/they are listening.

b. Eu vi crianças na sala. E ***ela** estava / **elas** estavam ouvindo.

I saw children in-the room. And she was/ they were listening.

(Schmitt & Munn, 2000:38)

Schmitt and Munn (2000) further discuss the effect of lack of number in bare singulars, which can be observed in aspectual interpretations. Following Verkuyl (1992), when there are quantized objects, terminative readings of verbs are obtained, while when there are non-quantized objects, durative interpretations are received. In Brazilian Portuguese, both bare singulars and bare plurals have the same function in this regard, as in (62a) and (62b), that is, both have durative interpretations; however, a singular indefinite, as in (62d), denotes a terminative

interpretation. Therefore, even though it is morphologically singular, a bare singular is not quantized:

(62) a. Eu escrevi carta por duas horas.

I wrote letter for two hours

I wrote letters for two hours.

b. Eu escrevi cartas por duas horas.

I wrote letters for two hours.

c. #Eu escrevi carta/cartas em duas horas.

I wrote letter/letters in two hours.

d. Eu escrevi uma carta em duas horas.

I wrote a letter in two hours.

(Schmitt & Munn, 2000:39-40)

Comparable evidence in Brazilian Portuguese is binominal *each*. Following Safir and Stowell (1988), Schmitt and Munn (2000) note that in Brazilian Portuguese, only the cardinal indefinite licenses binominal *each*, while bare plurals and bare singulars are not allowed in connection with binominal *each*, as shown in (63):

(63) a. Os países da UE mandaram um delegado cada.

The countries of-the EU sent one delegate each

The EU countries sent one delegate each.

b. *Os países da UE mandaram delegados cada.

The countries of-the EU sent delegates each

c. *Os países da UE mandaram delegado cada.

The countries of-the EU sent delegate each

(Schmitt & Munn, 2000:40)

In sum, in Brazilian Portuguese, bare singulars and bare plurals demonstrate no quantity information; and only bare singulars can function as antecedents of singular or plural pronouns. As a result, number is not projected in bare singular argument positions. Thus, bare singulars in Brazilian Portuguese have no quantity information and are unspecified. This is because of the Free Agr parameter, which allows the non-projection of number in argument positions.

Following the discussion of lack of number in argument positions in Brazilian Portuguese, I will show in the following section how lack of number is evidenced in argument positions in Persian.

5.3.1.4 Lack of number in bare singular arguments in Persian

In this section, I will show how in Persian a relationship between lack of number and bare singular arguments as a consequence of the Free Agr parameter is evidenced.

In Persian, a bare singular with an existential interpretation, such as *æsbab-bazi* ‘toy’ in (64), can have a singular or plural pronoun, *an* ‘it’ or *anha* ‘them’, as its reference:

- (64) *tu-ye otaq æsbab-bazi æst va bačče-ha darænd ba*
in-EZ room toy be.PRES-3SG and child-PL have.PROG-3PL with
an/anha *bazi=mi-kon-ænd.*
it/them play=DUR-do.PRES-3PL

‘There is/are a toy/toys in the room, and the children are playing with it/them.’

In Persian, as in Brazilian Portuguese, a bare plural, like *bæčče-ha* ‘children’ in (65), cannot have a singular pronoun as its reference, such as the third person singular null subject of the verbs *dar-ænd* and *bazi-mi-kon-ænd* in (65). However, a bare plural, like *bæčče-ha* ‘children’ in (66), is allowed as the antecedent of a plural pronoun, such as the third person plural null subjects of the verbs *dar-ænd* and *bazi-mi-kon-ænd* in (66):

(65) ***pesær-ha** tu-ye otaq hæst-ænd va **dar-ænd**
 boy-PL in-EZ room be.PRES-3PL and have.PROG-3SG
bazi=mi-kon-ænd.
 play=DUR-do.PRES-3SG

(66) **pesær-ha** tu-ye otaq hæst-ænd va **dar-ænd**
 boy-PL in-EZ room be-PRES.3PL and have.PROG-3PL
bazi=mi-kon-ænd.
 play=DUR-do.PRES-3PL

‘There are children in the room, and they are playing.’

Bare singulars in Persian can also be observed with aspectual interpretations when they are non-quantized and denote durative readings, like *name* ‘letter’ in (67a), whereas using bare plurals is generally not acceptable with terminative readings, like *name-ha* ‘letters’ in (67b). However, a singular indefinite in Persian, like *name-yi* ‘a letter’ in (67c), induces a terminative reading:

(67) a. u bæraye do saæ?t **name** nevešt.
 he/she for two hour letter write.PAST-3SG

‘He/She wrote a letter/letters for two hours.’

b. #u dær do saæ?t **name-ha** nevešt.
 he/she for two hour letter-PL write.PAST-3SG

‘He/She wrote letters in two hours.’

c. u **name-yi** ra dær do sa?æt nevešt.

he/she letter-IND OM in two hour write.PAST-3SG

‘He/she wrote a letter in two hours.’

Another construction in Persian in which bare singulars are allowed is the binominal *hær-kodam* ‘each’. Indefinite singulars with the cardinal indefinite or the enclitic *-i*, as in (68a), bare singulars, as in (68b), and indefinite plurals, as in (68d), are allowed in this construction. However, bare plurals are generally not allowed, as in (68c). When a bare singular is used in such constructions, as in (68b), number is unspecified:

(68) a. ostan-ha-ye qærbi har-kodam **yek namayande/namayande-yi**

province-PL-EZ western each one delegate/ delegate-IN

ferestad-ænd.

send.PAST-3PL

‘The western provinces each sent a delegate.’

b. ostan-ha-ye qærbi har-kodam **namayande** ferestad-ænd.

province-PL-EZ western each delegate send.PAST-3PL

‘The western provinces each sent a delegate.’

c. *ostan-ha-ye qærbi har-kodam **namayande-ha** ferestad-ænd.
 province-PL-EZ western each delegate-PL send.PAST-3PL

d. ostan-ha-ye qærbi har-kodam **namayande-ha-yi** ferestad-ænd.
 province-PL-EZ western each delegate-PL-IN send.PAST-3PL
 ‘The western provinces each sent (some) delegates.’

In Persian, as in Brazilian Portuguese, bare singulars bear no quantity information when they are antecedents to singular or plural pronouns; consequently, there is no projection of number in these bare singulars in argument positions in Persian. Therefore, bare singulars as antecedents to singular/plural pronouns in Persian are unspecified, as they do not bear any quantity information. There is lack of number in such bare singulars in argument positions in Persian because of the Free Agr parameter.

Having discussed the Free Agr parameter, I will show in the following section how Schmitt and Munn (2000) argued that the other parameter, the empty determiner parameter, makes the presence of bare singulars possible in Brazilian Portuguese.

5.3.2 Empty determiners in argument positions

Schmitt and Munn (2000) argued that the empty determiner parameter allows bare singulars to have empty determiners in argument positions in Brazilian Portuguese.

They argued that bare singulars are DPs, shown in (69), that do not have number projections. Consequently, \emptyset represents an empty D:

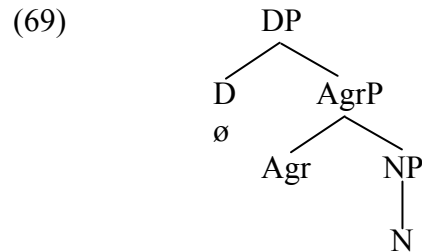

(Schmitt & Munn, 2000:36)

The evidence of NPs coordinated in Brazilian Portuguese shows that bare singulars are DPs rather than NPs. In example (70a), a single determiner conjoins two NPs. In (70a), the DP *o amigo e parente* ‘the friend and relative’ receives the meaning of a friend who is also a relative. However, the conjoined plural NPs in (70b) mean those who are friends and relatives at the same time. Also, it means the coordination of the friends and the relatives.

(70) a. Ele encontrou o amigo e parente no aeroporto.

He met the friend and relative in-the airport

He met the friend and relative at the airport.

b. Ele encontrou os amigos e parentes no aeroporto.

He met the friends and relatives in-the airport

He met the friends and relatives at the airport.

(Schmitt & Munn, 2000:41-42)

The bare singulars in (71) are not NPs as the coordination of them receives the interpretation of the plural DP in (70b) but not of the DP in (70a), that is, both have the ambiguity of having a separate individual interpretation and a conjoined predicate interpretation. Conjunctions at the NumP level and at the NP level are explanations for the separate individual interpretation and the conjoined predicate interpretation, respectively.

(71) Ele encontrou amigo e parente no aeroporto.

He met friend and relative in-the airport

He met friends and relatives at the airport.

(Schmitt & Munn, 2000:42)

However, the above explanation cannot provide the answer to the ambiguity of conjoined NumPs and conjoined NPs, as bare NPs lack number. Nevertheless, Brazilian Portuguese has another projection level, the DP projection, where conjunction occurs. Consequently, bare singulars have a DP projection, shown in the structure in (72) for the separate individual interpretation of the DP *amigo e parente* in (71):

(72)

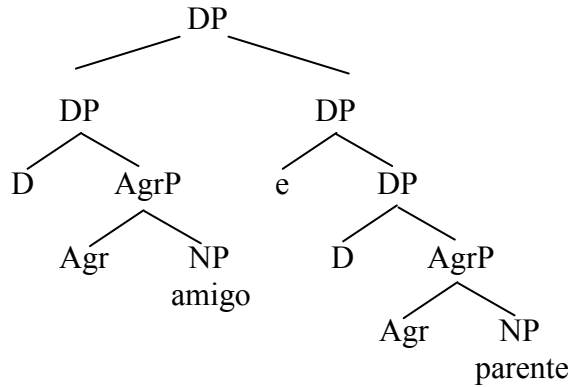

(Schmitt & Munn, 2000:43)

In sum, the data showing the coordination of bare singulars are evidence that bare singulars in argument positions in Brazilian Portuguese are DPs rather than NPs; however, because of the empty determiner parameter, Ds are null.

In the following section, I will discuss bare singulars in Persian and their relationship to NPs and DPs as well as null determiners.

5.3.2.1 The empty determiner in Persian

In Persian, which does not have any definite determiner, with the exception of the stressed *-e* in colloquial Persian, a bare singular can be kind-referring or definite. These can be distinguished by context. Ghomeshi (2008) argued that bare singulars in Persian are either NPs, which are kind-referring, or DPs with empty Ds denoting definiteness. What Ghomeshi claimed about Persian bare singulars having definite interpretations is compatible with what Schmitt and Munn (2000) claimed about bare singulars in Brazilian Portuguese. In both languages, a bare singular can be a DP with an empty D. Ghomeshi (2008) argued that the empty D in Persian can be

definite; moreover, I will argue that the empty D in Persian, following Vergnaud and Zubizarreta (1992), can be expletive if it denotes a type.

In order to exemplify a kind-referring bare singular and a definite bare singular in a context, Ghomeshi (2008) introduces part of a children's story *rubâh va xorus* 'the fox and the rooster' by Sobhi. A kind-referring noun such as *rubâh* 'fox' in (73) refers to this kind of animal as a group, not to any fox in particular:

(73) *xorus-i bud donya-dide ke čand bâr gereftâr-e rubâh šode bud*
 rooster-IND was world-seen that several time captured-EZ fox become was
 'There was a wise rooster who had been captured by a fox/foxes several times.'

(Ghomeshi, 2008:108-9)

When a particular fox is first introduced into the story, the indefinite enclitic-*i* is presented in the story, as shown in (74):

(74) *ruz-i dar birun-e deh sargarm-e dânečini bud ke az*
 day-IND in outside-EZ village busy-EZ grain-picking was that from
 dur did **rubah-i** be samt-aš be-do be-do mi-ây-ad
 distance saw.3SG fox-IND to direction-3SG.CL running running DUR.come-3SG

'One day he was picking grains outside the village when he saw from a distance a fox running towards him.'

(Ghomeshi, 2008:109)

In the following part of the story, (75), ‘the fox’ is the known character and is definite:

(75) **rubâh** pain-e deraxt âmad va goft ey xorus čera tâ ma-ræ
fox down-EZ tree came.3SG and said.3SG oh rooster why till me-OM
did-i bâlâ-ye deraxt pârid-i?
saw-2SG up-EZ tree jumped-2SG
‘The fox came to the foot of the tree and said. ‘O rooster, why did you jump
up the tree as soon as you saw me?’

(Ghameshi, 2008:109)

Although the bare singular *rubâh* ‘fox’ is kind-referring in (73), it is definite in (75). Therefore, Ghameshi (2008) raised the question of the syntactic distinction between a kind-referring noun, such as the one in (76a), and a definite bare noun, such as the one in (76c):

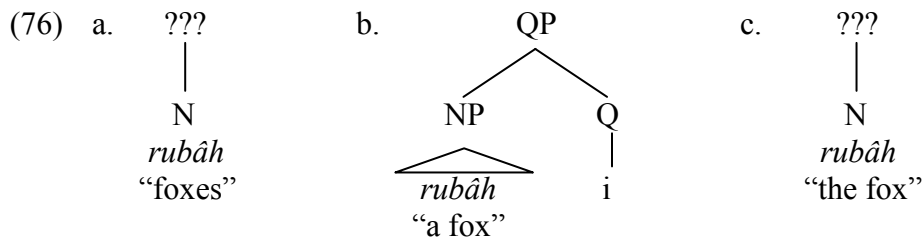

(Ghameshi, 2008:92)

She argued that (76a) and (76c) are of different syntactic categories, an NP and a DP, respectively. The DP has an empty D^0 -head. Therefore, a bare singular noun

picking out a referent has a phonologically definite determiner occupying a D⁰-head. Therefore, the difference between *rubâh* as a kind-referring noun and *rubâh* as a definite noun is as illustrated in (77):

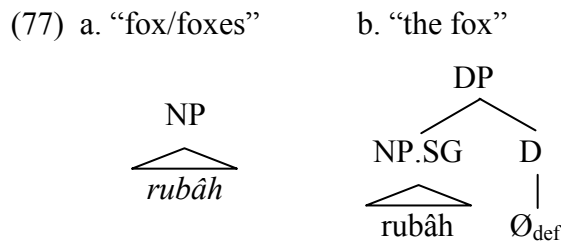

(Ghomeshi, 2008:93-4)

Therefore, the bare singular *ketâb* ‘book’ in object position in example (13a), repeated below as (78a), which is kind-referring, is of the syntactic category NP rather than DP. Moreover, such bare nouns, as Ghomeshi (2008) argued, are number-neutral. Bare plurals in object positions, as in (13b), repeated below as (78b), are very marked and have very restricted usage while carrying a particular connotation⁸¹. Following this interpretation, I argue that that NumP is not projected in bare plurals in object positions having the connotation of ‘all sorts of’. Therefore, the plural marker behaves as a modifier.

(78) a. ali ketâb xunde.

Ali book read.PART.3SG

‘Ali has read books.’

⁸¹ Bare plurals in object positions carry a connotation of amazement or surprise. as in: ‘You can’t imagine how many sorts of letters Ali has read.’

b. ali ketâb-a xunde.

Ali book-PL read.PART. 3SG

‘Ali has read all sorts of books.’ or ‘Ali has read a lot.’

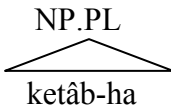
c. 
ketâb-ha

(Ghameshi, 2008:94-95)

Bare singulars in subject positions with a kind interpretation, as in (4a), repeated below as (79a), belong to the category NP. Bare plurals in subject positions, as in (4b), repeated below as (79b), which have kind readings, are interpreted as: ‘All children generally like cartoons.’ Because such bare plural in subject positions have subject-verb agreement, the presence of the plural marker is an indication of a NumP projection. Nevertheless, when bare singulars have definite interpretations, as in (79a), they belong to the category DP with a definite D⁰-head, while bare plurals with definite readings⁸², as in (79b), show the projection of NumP:

(79) a. **bæčče** karton dust=daræd.

child cartoon like=have.PRES-3SG

‘A/The child likes cartoons./Children like cartoons.’

kind/definite

⁸² I argue that bare plurals with definite reading in subject positions belong to category DP. When they receive definite interpretation, they have empty definite determiners; however, when they receive kind reading, they have expletive definite determiners, which will be discussed in §5.3.2.2.

b. **bæčče-ha** karton dust=darænd.

child-PL cartoon like=have.PRES-3PL

‘The Children/ Children like cartoons.’

kind/definite

In sum, bare singulars in subject or object positions in Persian receive kind readings, and they belong to the NP category. When bare plurals are in object positions, Num is not present, and the plural marker functions as a modifier. However, when bare plural with kind reading are in subject positions, there is NumP projection. Because of the empty determiner parameter, when definite bare singulars/plurals are in subject or object positions, they belong to the DP category, with empty Ds.

5.3.2.2 The expletive determiner in Persian

If the object marker *ra* follows a bare singular in a direct object position, like the bare singular in (78a), it becomes *ra*-marked, as in (80a), and receives a definite interpretation. The *ra*-marked noun belongs to the DP category, with an empty definite determiner. If the object marker *ra* follows a bare plural, as with the bare plural in (78b), it induces a definite reading, as in (80b), and the presence of the plural marker is an indication that the category NumP is projected:

(80) a. ali ketâb-ra xunde.

definite

Ali book-OM read.PART-3SG

‘Ali has read the book.’

b. ali ketâb-ha-ra xunde. definite

Ali book-PL-OM read.PART-3SG

‘Ali has read the books.’

However, there are cases in which objects of kind-selecting verbs, as in (37a) and (38a), repeated below as (81) and (82), are *ra*-marked. Objects of kind-selecting verbs are different from kind-referring bare singulars in object positions, as in (43a) repeated below as (83). Although objects of kind-selecting verbs in Persian are kind-referring, they are *ra*-marked; therefore, they must be distinguished from kind-referring bare singulars in object positions in Persian, like those in (83), which belong to the category NP. The object marker *ra* that follows the objects of kind-selecting verbs shows that they belong to the DP category rather than to the NP category:

(81) a. bærådær-an-e rayt **hævapeyma-ra** extera?=kærd-ænd.

brother-PL-EZ Wright airplane-OM invention=do.PAST-3PL

‘The Wright brothers *invented* the *airplane*.’

(82) xodavænd **ensan-ra** xælq=kærd.

God human-OM creation=do.PAST-3SG

‘God created the human.’

(83) u **dæftær** xærid.

he/she notebook buy.PAST-3SG

He/She bought a notebook/ notebooks.

kind

The object marker *ra* can also be used with generic nouns. Ghomeshi (2003) argues that singular direct objects, as in (34a) repeated below as (84), are generic while they are *ra*-marked:

(84) Sīrka **shīr rā** mi-burrad.

vinegar milk OM DUR-curdle-3SG

‘Vinegar curdles milk.’

(Dabir-Moghaddam, 1992:557)

As Ghomeshi (1996) argued, *ra* is a Kase Phrase selecting for a DP complement. Therefore, if a noun is *ra*-marked, it does not belong to the NP category. Nevertheless, there must be a difference between *ra*-marked nouns with kind/generic readings as in (81), (82), and (84) and remarked nouns with definite readings as in (80a) and (80b).

Consequently, I propose that because of the empty determiner parameter, a *ra*-marked bare noun in the object position of a kind-selecting verb, as in (81) or (82), a kind/generic noun, as in (84), has an empty D, but the empty definite determiner is expletive, following Vergnaud and Zubizarreta (1992). In order to analyze whether Persian empty Ds can be expletive, first, I will show how Vergnaud and

Zubizarreta (1992) argued for the function of the expletive determiner in French. Next, I will compare and contrast the function of the expletive determiner in French to that of Persian.

Vergnaud and Zubizarreta (1992) argued that the definite determiner *le* in French can be expletive if the NP denotes a type. They contrasted French and English definite determiners to determine why French has an expletive determiner while English does not have this determiner. They suggested that in French the definite determiner is an expletive if an NP denotes a *type*, as in (85):

(85) On a donné *le* *même ordinateur*

Someone gave *SING DEF DET same computer*

à Sophie, à Justine, et à Cléa.

to Sophie, to Justine , and to Cléa

(Vergnaud & Zubizarreta, 1992:605)

Sentence (85) can have token or type interpretation. With the token interpretation, each of these persons, Sophie, Justine, and Cléa, received one physical computer of the same type. Hence, *le même ordinateur* induces a *token* interpretation. Nevertheless, if all of these persons, Sophie, Justine, and Cléa, received just one physical computer, the nominal expression *le même ordinateur*, induces a *type* interpretation.

Vergnaud and Zubizarreta (1992) distinguished between *type* and *token* in domain D. They argued that in the following diagram, the head of D gives rise to a maximal projection when it takes a complement that is an NP projection:

(86)

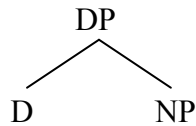

(Vergnaud & Zubizarreta, 1992:612)

This argument presumes the *Correspondence Law* which explains how the syntactic categories associate with the semantic types:

(87) *Correspondence Law*

When a DP or an NP denotes, the DP denotes a token and the NP denotes a type.

(Vergnaud & Zubizarreta, 1992:612)

Therefore, in (86), the DP may be token-indexed and the NP may be type-indexed. To assign tokens, Vergnaud and Zubizarreta (1992) used numbers (1,2,3,...), and to assume types, they used lower-case letters (i, j, k,...), as in (88), which shows how *ce chat* ‘this cat’, as a definite nominal expression, denotes a token:

(88)

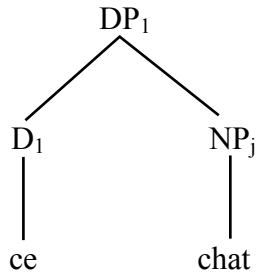

(Vergnaud & Zubizarreta, 1992:613)

However, a sentence such as (85), repeated below as (89), can have two interpretations: token and type. If the token interpretation is taken, the definite determiner *le* is indexed the same as *ce* ‘this’ in (88):

(89) On a donné *le* *même ordinateur*
 someone gave *SING DEF DET same computer*
 à Sophie, à Justine, et à Cléa.
 to Sophie, to Justine , and to Cléa

(Vergnaud & Zubizarreta, 1992:614)

Taking the type interpretation into consideration, Vergnaud and Zubizarreta (1992) hypothesized the following for the definite determiner *le* in French:

(90) In French the definite determiner *le* may function as an expletive from the point of view of denotation.

(Vergnaud & Zubizarreta, 1992:615)

Having the type interpretation, the definite determiner has no denotational index; therefore, the determiner *le* has the function of an expletive, as in (91). To simplify the nominal expression *le même ordinateur* to the DP *l'ordinateur*, the adjective *même* is ignored:

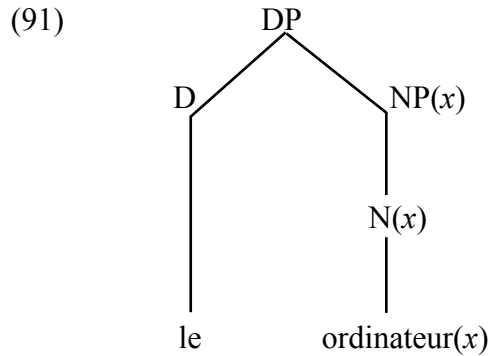

(Vergnaud & Zubizarreta, 1992:615)

However, in English, when a nominal expression has a *type* interpretation, the definite determiner *the* is absent, as in (92):

- (92) a. Dogs are mammals.
 b. Whales are becoming extinct.

(Vergnaud & Zubizarreta, 1992:635)

Consequently, Vergnaud and Zubizarreta (1992) proposed the following parameter, which clarifies the contrast between French and English definite determiners:

(93) The definite determiner may function as an expletive from the point of view of denotation in French but not in English.

(Vergnaud & Zubizarreta, 1992:635)

In Persian, nominal expressions receiving *type* or *token* interpretations look very similar. The sentence in (39a), repeated below as (94a), has a *ra*-marked nominal expression *alkol* ‘alcohol’ with an empty definite D. This nominal expression refers to the *type* of the object discovered; however, the *ra*-marked nominal expression *alkol* ‘alcohol’ in (94b), having an empty definite D, means *Sarah bought (the bottle/container of) the alcohol*. Therefore, (94b) refers to a *token*:

(94) a. razi **alkol-ra** kæšf=kærd.

Razi alcohol-OM discovery=do.PAST-3SG

‘Razi discovered alcohol.’

b. sara **alkol-ra** xærid.

Sarah alcohol-OM buy.PAST-3SG

‘Sarah bought the alcohol.’

Following Vergnaud and Zubizarreta (1992), I propose the following parameter for Persian:

(95) The definite determiner with an empty head in Persian is an expletive if it is *type*-denoting.

Hence, I argue that *ra*-marked nominal expressions with kind/generic interpretations, repeated below as (96), (97), (98), and (99) are distinguished from *ra*-marked definite nominal expressions, as in (80), repeated below as (100). The *ra*-marked nominal expressions in the former examples have the expletive determiners as the definite null determiners denote a *type* while the *ra*-marked nominal expressions with the definite null determiners in the latter examples have *token* interpretations:

(96) bærådær-an-e rayt **hævapeyma-ra** extera?=kærd-ænd.

brother-PL-EZ Wright airplane-OM invention=do.PAST-3PL

‘The Wright brothers *invented* the *airplane*.’

(97) xodavænd **ensan-ra** xælg=kærd.

God human-OM creation=do.PAST-3SG

‘God created the human.’

(98) Sīrka **shīr rā** mi-burrad.

vinegar milk OM DUR-curdle-3SG

‘Vinegar curdles milk.’

(Dabir-Moghaddam, 1992:557)

(99) xod-æt ke **mærd-ha-ra** mi-šenas-i.

self-2SG.CL FOC man-PL-OM DUR-know-2SG

‘You yourself know men.’

[*Like Water for Chocolate*, p. 130, by Laura Esquivel,
translated by Maryam Bayat, in Ghomeshi, 2003:51]

(100) a. ali **ketâb-ra** xunde.

definite

Ali book-OM read.PART-3SG

‘Ali has read the book.’

b. ali **ketâb-ha-ra** xunde.

definite

Ali book-PL-OM read.PART-3SG

‘Ali has read the books.’

Therefore, I argue that the nominal expression *hævapeyma* ‘airplane’ in (96) having a null definite expletive determiner receives a type interpretation and the definite expletive determiner has no denotational index, as in (101). However, the nominal expression *ketab* ‘book’ in (100a) having a null definite determiner

receives a token interpretation and the null definite determiner is indexed, as in (102):

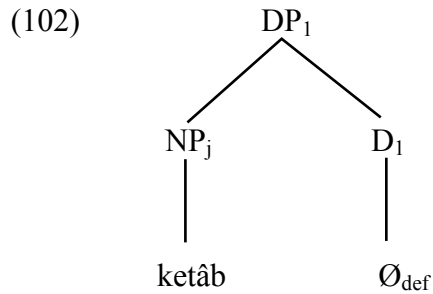
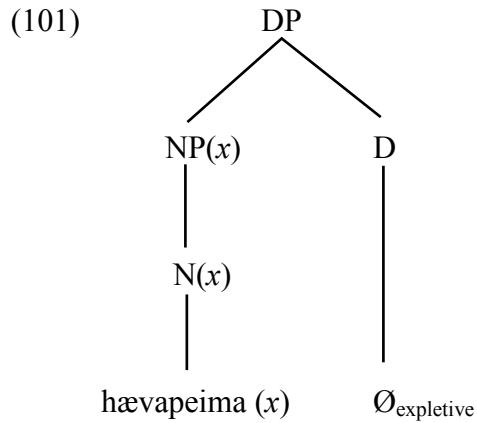

In §5.3.2.1, I argued that bare plurals in subject positions either receive kind or definite reading while belonging to category DP with empty definite determiners, as in (79b), repeated below as (103). However, there must be a difference between the kind and definite interpretations.

(103) bæčče-ha karton dust=darænd.

child-PL cartoon like=have.PRES-3PL

‘The Children/ Children like cartoons.’

kind/definite

Therefore, I argue if a bare plural in a subject position receives a kind reading, the null definite determiner is expletive because it denotes a *type*, but if a bare plural in a subject position receives a definite interpretation, the definite null determiner denotes a *token*.

That there is a definite determiner with an empty head, either as an expletive definite determiner or merely as a definite determiner, in argument positions in Persian is compatible with the second parameter, which allows bare singulars having empty determiners in argument positions.

In sum, a definite singular/plural in an object position must be *ra*-marked. When bare a singular/plural is *ra*-marked, it receives either a token or a type interpretation. A bare plural in a subject position also receives a token or type interpretation. When in these situations a token interpretation is received, there is an empty definite determiner; however, when there is a type reading, the empty definite determiner is expletive.

5. 4. Summary

The distribution of bare singulars/plurals in Persian shows that the two morpho-syntactic parameters, the Free Agr parameter and the empty determiner parameter, are responsible for licensing Persian bare singulars/plurals in argument and

predicative positions, as in Brazilian Portuguese. The Free Agr parameter is responsible for split Num and Agr in predicative and argument positions. The empty determiner parameter is responsible for licensing bare singulars/plurals in argument positions, which is in accordance with Ghomeshi's (2008) claim that Persian bare singulars/plural are DPs with empty D^0 -head. Also, she argued that Persian bare singulars/plurals can be NPs which are kind-referring. Therefore, their singular or plural values are unspecified, and their plural marking is not a result of the projection of a NumP category, yet it is modificational. However, the plural marking of bare singulars/plurals belonging to the DP category shows the projection of NumP.

While Persian DPs have empty definite determiners, I argue that empty definite determiners can be expletive in certain conditions, following Vergnaud and Zubizarreta (1992). When bare singulars/plurals receive type interpretations, empty definite determiners are expletive; nevertheless, when they denote token interpretations, DPs merely have empty definite determiners.

Chapter 6: Concluding remarks

In this thesis, I have explored the nature of plural marking in Persian in the framework of the principles and parameters theory, particularly, the two plural marking parameters proposed by Wiltschko (2007, 2008). Under the two parameters of plural marking, the plural marker either merges as a functional category head or adjoins nominal roots as a root modifier. The plural marker functioning as a head is assumed to be inflectional while the modificational plural marker is derivational. However, I have argued that it is too strict to consider plural marking as ‘functional head’ as opposed to plural marking as ‘modifier’. Rather, following Booij’s (1993, 1995) proposal that inflectional morphology can be used contextually and inherently, I propose that plural marking in Persian is inflectional but has some derivational residues.

The core discussion of this thesis has clustered around the projection of the functional category Number Phrase (NumP) in Persian and its relevance to inflectional plural marking. I propose that the functional category NumP projects in Persian and the plural marker, being inflectional, occupies the head of NumP. Furthermore, based on empirical evidence, I have argued that classifiers and the plural marker are in complementary distribution; therefore, either classifiers or the plural marker occupies the head of NumP. I also propose that both classifiers and the plural marker have the role of individualizing nouns in Persian while occupying syntactic heads.

In order to investigate the properties of plural marking in Persian, I have adopted the diagnostics introduced by Wiltschko (2008) for inflectional plural marking. In Chapter 2, I have provided a detailed analysis of the properties of plural marking in Persian. The diagnostics have shown that Persian plural marking is mostly inflectional; however, it has some residues of derivational morphology. As a result, I propose that the plural marker in Persian adjoins as a modifier to nominal roots when it is derivational.

In connection with the discussion of inflectional plural marking in Persian, I have argued in Chapter 3 that the functional category NumP projects in Persian and the plural marker merges as the head of the functional category. Following Borer's (2005) proposal that NumP heads can be occupied either by the plural marker or by classifiers, I have argued that classifiers in Persian also occupy the head of NumP, but they are in complementary distribution. Accordingly, I propose that both classifiers and the plural marker in Persian have the role of individualizing nouns, and that countability is at the level of both plural marking and classifiers in Persian. Assuming that in Persian NumP projects and its head is occupied by means of number marking, namely classifiers or the plural marker, I propose that there is a mass/count distinction in Persian.

Plural marking in Persian also has some derivational properties, which result in the plural marker having a modificational role when there is pluralisation of mass nouns with a 'large amount of mass' interpretation. Persian nominal roots can also be underspecified for mass/count values, which results in the absence of the NumP projection.

In Chapter 4, I have provided a detailed discussion of Persian classifiers in relation to the discussion of number marking in Chapter 3. I have argued that Persian classifiers, having a role in number marking, have optional uses. As Persian plural marking cannot occur in indefinite noun phrases with cardinals or in combinations of cardinals and classifiers, I propose that when a classifier is not full, there is an empty classifier that is also in complementary distribution with the plural marker. I further propose that either full/empty classifiers or the plural marker occupies the head of NumP, which explains that they are in complementary distribution. In definite noun phrases, the plural marker can optionally occur. I have argued that the plural marker in definite noun phrases has a modificational role.

In Chapter 5, I have investigated the characteristics of bare singulars/plurals in Persian in relation to the projection of NumP. I have argued that the two morpho-syntactic parameters introduced by Schmitt and Munn (2000), known as the Free Agr parameter and the empty determiner parameter, allow bare singulars/plurals in Persian in some argument and predicative positions. I propose that the independent functions of Num/Agr heads in Persian license bare singulars in predicative positions.

The discussion of the empty determiner parameter is in line with Ghomeshi's (2008) proposal that Persian definite bare nouns belong to DPs with D^0 -heads. As a result, I have assumed that the empty determiner parameter is required in Persian to license definite bare singulars/plurals in argument positions.

In connection with the study of bare singulars/plurals in object positions, I have argued that direct objects in Persian are followed by the object marker *ra*, and

have a type or token interpretation. Also, I have argued that bare plurals in subject positions can have a type or token reading. Vergnaud and Zubizarreta (1992) argue that a definite determiner in French can be expletive if it induces a type reading. However, a token interpretation is received if a definite determiner is not expletive. For Persian, I propose that an empty definite determiner in an object or a subject position is expletive if a type interpretation is received; however, a token interpretation indicates that the empty definite determiner is not expletive.

Having discussed the findings of this study, it is interesting to investigate some other languages in order to realize whether inflectional plural morphology can be used contextually as well as inherently, whether the pluralisation of mass nouns has modificational role although plural marking is generally inflectional, whether plural marking and classifiers occupy the same functional head both individualizing nouns and being in complementary distribution, and whether bare nouns in different languages behave the same as bare nouns in Persian because of the two morpho-syntactic parameters.

References

- Abbassi, Azita (2002). Countability in Farsi. *Iranian Journal of Linguistics*. 17(1):9-21.
- Acquaviva, Paoblo (2006). Plural mass nouns and the compositionality of number. *Verbum* 26/4: 387-401.
- Ahmadi-Givi, Hassan, & Hassan Anvari (1997). *Dæstoore zæban-e Farsi 1* [Persian Language Grammar 1]. Tehran: Fatemi Press.
- Anscombe, J-C (1987). Article zéro en français: un imparfait du substantif? *Langue Française*. 62:1-39.
- Anvari, Hassan, & Hassan Ahmadi-Givi (1997). *Dæstoore zæban-e Farsi 2* [Persian Language Grammar 2]. Tehran: Fatemi Press.
- Batani, Momamad Reza (1976). *Four speeches on language*. Tehran: Agah Press.
- Beard, Robert (1998). Derivation. In Andrew Spencer & Arnold M. Zwicky (Eds.), *The handbook of morphology*, 44-65. Malden: Blackwell Publishers.
- Bisang, Walter (1993). Classifiers, Quantifiers and Class Nouns in Hmong. *Studies in Linguistics* 17:1-51
- Bobaljik, Jonathan (1995). Morpho-syntax: the syntax of verbal inflection. Ph.D. Dissertation, MIT, Cambridge, Mass.
- Booij, Geert (1993). Against split morphology. In Booij, Geert, & Jaap van Marle (Eds.), *Yearbook of Morphology*, 27-50. Dordrecht: Kluwer.

- Booij, Geert (1995). Inherent versus contextual inflection and the split morphology hypothesis. In Booij, Geert, & Jaap van Marle (Eds.), *Yearbook of Morphology*, 1-16. Dordrecht: Kluwer.
- Borer, Hagit (2005). *In name only*. New York: Oxford University Press.
- Burling, Robbins (1965). How to choose a Burmese numeral classifier. In M. Spiro (Eds), *Context and meaning in cultural anthropology (Festschrift Hallowell)*, 243-264. New York.
- Cheng, Lisa, & Rint Sybesma (2005). Classifiers in four varieties of Chinese. In Cinque, Guglielmo, & Kayne, Richard (Eds.). *The Oxford Handbook of Comparative Syntax* 259-292. Oxford University Press: Oxford.
- Cheng, Lisa, & Rint Sybesma (1999). Bare and not-so-bare nouns and the structure of NP. *Linguistic Inquiry* 30:509-542.
- Cheung, Pierina, David Barner, & Peggy Li (2009). Syntactic cues to individuation in Mandarin Chinese. *Journal of Cognitive Science* 10:135-147
- Chierchia, Gennaro (1998). Reference to kinds across languages. *Natural Language Semantics* 6:339-405.
- Chomsky, Noam (1995a). *The minimalist program*. Cambridge: MIT Press.
- Chomsky, Noam (1998). Minimalist inquiries: The framework. *MIT occasional papers in linguistics* 15. Cambridge: Department of Linguistics, MITWPL, MIT.
- Chomsky, Noam (1999). Derivation by Phase. *MIT occasional papers in linguistics* 18. Cambridge: Department of Linguistics, MITWPL, MIT.

- Chomsky, Noam (2000). Minimalist Inquiries: the framework. In Roger Martin, David Michaels, & Juan Uriagereka (Eds.), *Step by step: Essays in minimalist syntax in honor of Howard Lasnik*, 8-153. Cambridge: MIT Press.
- Chomsky, Noam (2001). Beyond explanatory adequacy. *MIT occasional papers in linguistics* 20. Cambridge: Department of Linguistics and Philosophy, MITWPL, MIT.
- Corbett, Greville (2000). *Number*. Cambridge: Cambridge University Press.
- Dabir-Moghaddam, Mohammad (1992). On the (in)dependence of syntax and pragmatics: Evidence from the post-position -rā in Persian. In Dieter Stein (Ed.), *Cooperating with written texts*, 549-573. Berlin & New York: Mouton de Gruyter.
- Daley, Keren (1998). *Vietnamese classifiers in Narrative Texts*. Summer Institute of Linguistics, University of Texas at Arlington.
- Déchaine, Rose-Marie, and Martina Wiltschko (2002). Decomposing pronouns. *Linguistic Inquiry* 33:409-442.
- Dogaru, Mihaela Tanase (2005). Bare nouns and the projection of number in English and Romanian. *Analele Universitatii Bucuresti*. Available from *escoala.ro* [http://www.e-scoala.ro/limbi-straine/bare_nouns.html], accessed 25/07/2011.
- Embick, David, & Rolf Noyer (2006). Distributed Morphology and the Syntax/Morphology Interface. In G. Ramchand & C. Reiss (Eds.), *The Oxford Handbook of Linguistic Interface*, 289-325. Oxford University Press.

- Fassi Fehri, Abdelkader, & Marie-Thérèse Vinet (2007). Number and classifier distribution in Arabic and Chinese and their complementarity. In Annie Zeanen, Jane Simpson, Tracy Holloway King, Jane Grimshaw, Joan Mailing, & Chris Manning (Eds.), *Architectures, Rules, and Preferences: Variations on Themes of Joan Bresnan*, Stanford University: CSLI (Center for the Study of Language and Information) Publications.
- Galloway, Brent (1980). *The structure of upriver Halkomelem*. Berkeley: University of California Press.
- Galloway, Brent (1993). *A grammar of upriver Halkomelem*. Berkeley: University of California Press.
- Ganjavi, Shadi (2007). Direct objects in Persian. Ph.D. Dissertation. University of Southern California.
- Gebhardt, Lewis (2008). Classifiers, plural, and definiteness in Persian. In Simin Karimi, Vida Samian, & Donald Stilo (Eds), *Aspects of Iranian Linguistics*, 35-55. Cambridge Scholars Publishing Company.
- Ghaniabadi, Saeed (2010). The empty noun construction in Persian. Ph.D. Dissertation. University of Manitoba.
- Ghomeshi, Jila (1997b). Topics in Persian VPs. *Lingua* 102:133-167.
- Ghomeshi, Jila (2001). Control and thematic agreement. *Canadian Journal of linguistics* 46(1/2): 8-40.
- Ghomeshi, Jila (2003). Plural marking, indefiniteness, and the noun phrase. *Studia Linguistica* 57(2):47-74.

- Ghameshi, Jila (2008). Markedness and bare nouns in Persian. In Simin Karimi, Vida Samiian, & Donald Stilo (Eds.), *Aspects of Iranian Linguistics*, 85-112. Cambridge Scholars Publishing.
- Greenberg, Joseph H. (1972). Numeral classifiers and substantival number: Problems in the genesis of a linguistic type. *Working Papers on Language Universals* 9:2-39.
- Hofling, Charles Andrew (2000). *Itzaj Maya Grammar*. Salt Lake City: The University of Utah Press.
- Hopper, Paul (1986). Some Discourse functions of classifiers in Malay. In C. G. Craig (Eds.), *Noun Classes and categorization*, 309-325. John Benjamins: Amsterdam.
- Jaisser, Annie (1987). Hmong Classifiers. *Linguistics of the Tibeto-Burman Area* 10:169-75.
- Kahnemuyipour, Arsalan (2000). On the derivationality of some inflectional affixes in Persian. *Annual Meeting of the Linguistic Society of America*. Chicago.
- Kahnemuyipour, Arsalan (2004). Non-projecting features: Evidence from Persian. *Annual Meeting of the Linguistic Society of America*. Boston.
- Karimi, Simin (1989). Aspects of Persian syntax, specificity, and the theory of grammar. Ph.D. Dissertation, University of Washington.
- Karimi, Simin (1990). Obliqueness, specificity, and discourse functions. *Linguistic Analysis* 20:139-191.
- Karimi, Simin (1999a). A note on parasitic gaps and specificity. *Linguistic Inquiry* 30, 704-713.

- Karimi, Simin (2003c). Object positions, specificity, and scrambling. In Simin Karimi (Ed.), *Word Order and scrambling*, 91-125. Blackwell Publishers
- Karttunen, L. (1976). Discourse referents. In J. McCully (Ed.), *Syntax and semantics, Notes from Linguistic Underground*, 363-385. New York: Academic Press.
- Krasil'nikova, E. V. (1990). *Imja suščestvitel'noe v russkoj razgovornoj reči: Funkcional'nyj aspekt*. Moscow: Nauka.
- Lyon, Christopher (1999). *Definiteness*. Cambridge: Cambridge University Press.
- Mathieu, Eric (2007). The count/mass distinction and the role of number in Ojibwe. Talk presented at the Workshop on Nominal and Verbal Plurality, November 9-10. Paris.
- Mathieu, Eric (2009). On the mass/count distinction in Ojibwe. Volume edited by Diane Massam. Oxford University Press.
- Mathieu, Eric (2011). Flavors of division. Ms. University of Ottawa.
- McDonald, R. Ross (1967). *Indonesian reference grammar*. Washington, D.C.: Georgetown University Press.
- Oosterhof, Albert (2004). Generic noun phrases in Dutch. In Fred Karlsson (Ed.), *Proceeding of 20th Scandinavian Conference of Linguistics*, 36,1-22. January 7-9. University of Helsinki, Department of General Linguistics.
- Perlmutter, David M. (1988). The split morphology hypothesis: Evidence from Yiddish. In Michael Hammond & Michael Noonan (Eds.), *Theoretical morphology: approaches in modern linguistics*, 79-100. San Diego. Academic Press.

- Piriyawiboon, Nattaya (2008). The syntax of numeral classifiers. General paper. University of Toronto.
- Ritter, Elizabeth (1995). On the syntactic category of pronouns and agreement. *Natural language and Linguistic Theory* 13:405-443.
- Samiian, Vida (1983). Origins of phrasal categories in Persian, an X-bar analysis. Ph.D. dissertation, UCLA.
- Saul, Janice E., & Nancy Freiberger Wilson (1980). *Nung Grammar*. Dalas: SIL (Publications in Linguistics, 62).
- Schmitt, Cristina, & Alan Munn (2000). Bare nominals, morphosyntax, and nominal mapping parameter. Ms. Michigan State University.
- Sedighi, Anousha (2005). Subject-predicate agreement restrictions. Ph.D. dissertation, University of Ottawa.
- Sedighi, Anousha (2007). *Agreement restrictions in Persian*. Amsterdam & West Lafayette: Rozenberg Publishers & Purdue University Press.
- Sharifian, Farzad, & Ahmad R. Lotfi (2003). “Rices” and “waters”. The mass-count distinction in Modern Persian. *Anthropological Linguistics* 45:226-244.
- Simpson, Andrew (2005). Classifiers and DP structure in Southeast Asia. In Cinque, Guglielmo, & Kayne, Richard (Eds.), *The Oxford Handbook of Comparative Syntax*, 806-837. Oxford University Press: Oxford.
- Stump, Gregory T. (1998). Inflection. In Andrew Spencer & Arnold M. Zwicky (Eds.), *The handbook of morphology*, 13-43. Malden: Blackwell Publishers.

- Tang, Chih-Chen Jane (2004). Two types of classifier languages: A typological study of classification markers in Paiwan noun phrases. *Language and Linguistics* 5.2: 377-407.
- Tonciulescu, Keren (2009). Kind of predicates and reference to kinds in Hebrew. In Ghomeshi, Jila, Ileana Paul, & Martina Wiltschko (Eds.), *Determiners*, 159-174. John Benjamins Publishing.
- Travis, Lisa DeMena (1984). Parameters and Effects of Word Order Variation, Ph.D. Dissertation. MIT.
- Travis, Lisa, & Greg Lamontagne (1992). The case filter and licensing of the Empty K, *Canadian Journal of Linguistics* 37:157-174.
- Tsoulas, George (2007). On the grammar of number and mass terms in Greek. Ms., University of York.
- Valentine, Randy (2001). *Nishnaabemwin reference grammar*. Toronto: University of Toronto Press.
- Vergnaud, Jean-Roger, & Maria Luisa Zubizarreta (1992). The definite determiner and inalienable construction in French and English. *Linguistic Inquiry* 23:595-652.
- Verkuyl, Henk (1993). *A Theory of Aspectuality*. Cambridge: Cambridge University Press.
- Wasow, Tom (1977). "Transformation and the lexicon". In Tom Wasow, Peter Culicover, & Joan Bresnan (Eds.), *Formal Syntax*. 327-360. New York: Academic Press.

- Whitney, Arthur H. (1956). *Teach Yourself Finnish*. London: English Universities Press. [Quoted from 11th impression 1989.]
- Wiltschko, Martina (2007). On the absence of a grammaticized mass/count distinction in Halkomelem Salish. Ms. University of British Columbia.
- Wiltschko, Martina (2008). The syntax of non-inflectional plural marking. *Natural language and linguistic theory* 26:639-694.
- Windfuhr, Gernot L. (1979). *Persian grammar: History and state of its study*. The Hague: Mouton Publishers.