

# Fleet Performance Monitoring System Using The Internet of Things (Business Model)

by

Maryam Alsobhi

Thesis submitted to the  
Faculty of Graduate and Postdoctoral Studies  
In partial fulfillment of the requirements  
For the M.Sc degree in  
Systems Science

School of Electrical Engineering and Computer Science  
Faculty of Engineering  
University of Ottawa

© Maryam Alsobhi, Ottawa, Canada, 2018

## Abstract

Fleet management is one of the most challenging tasks faced by fleets managers. These companies need to shed light on several aspects that have direct and indirect impacts on their businesses. For instance, monitoring driver performance and behaviour can be used as a mean to improve their operational efficiency and effectiveness, which may lead to increase customer satisfaction. Technological advances have made it possible for fleet companies to monitor fleet drivers. The Internet of things (IoT), is one of these technologies, which is a network of connected devices embedded with sensors through the internet, allowing them to communicate with one another and exchange information. Due to increase in societies needs, fleet companies need to maximize their operations. Thus, they encounter high operational costs and productivity issues that cost them a lot economically and environmentally. There are many suggested solutions on how to reduce costs such as reduce the number of operations. In this thesis we are suggesting using IoT to monitor fleet performance in order to cut unnecessary expenditure and improve efficiency, particularly by managing driver as a mean to overcome the problem. IoT solution works by implementing number of sensors to do specific function (for example: detecting risky event and warn fleet's driver) and generate data. Data are valuable for businesses in order to make better decisions that may lead to increase revenues and reduce costs. The simulation of our suggested solution shows improvement on fleet performance compare to non-IoT solutions. Then, we build an innovative sustainable business model to illustrate the benefits that fleet businesses can get by implementing such a solution predominantly because IoT is an economic and multi-purpose solution that can be used to solve a number of crossover problems.

## Acknowledgements

The journey of completing a master's thesis while being a wife and a mother was not easy. This endeavour was full of challenges and barriers. Without a group of great people, I would not have been able to proceed and succeed at this task. I am deeply grateful to them for all the support and love they provided me to achieve my dream.

First and foremost, I would like to express my gratitude to **God** for giving me the health and strength needed throughout this process.

I owe a special thank you to my partner and soul mate, **Abdulmajeed**, for his unlimited love and support. This thesis would not have been possible without his help every step of the way. Thank you for holding my hand from the beginning until this stage. Thank you from my heart for your love, guidance, motivation, understanding and cooperation. I am dedicating this thesis to you as you have been the biggest contributor and this would not have been possible without the power you have given me. I am deeply appreciative of your belief in me and your remarkable efforts to help me reach my goals.

I also dedicate this thesis to my daughters **Malak and Judy**. You are my precious inspiration. You have provided me with the strength necessary to work on my thesis in order to provide the best future for you. I appreciate the patience that you showed me while I was writing my thesis. Without you in my life, I would not think about the future and I would not be encouraged to make it brighter by completing such work.

A special thank you to my beloved parents, **Nour and Hamed**, for their faith in me and their belief that I could one day have as much success as I do today. Thank you for supporting my decision and encouraging me to travel abroad and complete my studies. Thank you for all the care, love, motivation, and support you have given to me and to my little family. I would also like to express my gratitude to my best friend and best sisters, **Manal and Kholoud**, for their motivation and support.

Finally and most importantly, I would like to thank my thesis supervisors **Dr. Tet Yeap** from the school of Engineering and Information Technology and **Dr. Morad Benyoucef** from the Telfer school of Management for giving me the opportunity to work under their

supervision. I am very fortunate that they agreed to supervise my thesis. I would like to thank you for your unlimited support, valuable insights, and treasured suggestions. Your consistent follow up was very appreciated throughout this process.

## Dedication

I would like to dedicate this work to everyone who has helped throughout this journey, in both my personal and academic life; without your support it would not have been possible to achieve my dream.

# Table of Contents

List of Tables	ix
List of Figures	x
<b>1 Introduction</b>	<b>1</b>
1.1 Motivations . . . . .	1
1.2 Problems . . . . .	2
1.3 Methodology . . . . .	3
1.4 Contribution . . . . .	3
1.5 Thesis Organization . . . . .	4
<b>2 Background and Related Work</b>	<b>5</b>
2.1 Fleet Logistics . . . . .	5
2.1.1 Transportation Information Systems (TIS) . . . . .	6
2.2 Fleet Management . . . . .	6
2.2.1 Fleet Management Areas . . . . .	6
2.2.2 Fleet Management Problems . . . . .	7
2.3 Current Logistics and Fleet Systems . . . . .	12
2.3.1 Safety Systems that are based on Driver's Monitoring for Economic and Social Purposes . . . . .	12

2.3.2	Safety Systems Designed for Environmental Purposes . . . . .	16
2.4	The Internet of Things . . . . .	18
2.4.1	IoT Definitions . . . . .	18
2.4.2	IoT Components . . . . .	19
2.4.3	Current and Potential IoT Applications . . . . .	22
2.5	Business Model . . . . .	24
2.5.1	Definition Analysis . . . . .	24
2.6	Current available Business Models Building Blocks . . . . .	26
2.6.1	Example of BM Framework . . . . .	31
2.6.2	Main Purpose of Building a Business Model for IoT . . . . .	31
2.6.3	Business Model Gap . . . . .	32
<b>3</b>	<b>Proposed Approach</b>	<b>34</b>
3.1	First Step . . . . .	34
3.1.1	System Description . . . . .	35
3.1.2	Simulation Environment . . . . .	35
3.1.3	Data Collection and Assumptions . . . . .	38
3.2	Second Step . . . . .	42
3.2.1	Planning Stage . . . . .	42
3.2.2	Conducting and Reporting Stages . . . . .	43
<b>4</b>	<b>Simulation and Modeling of The Proposed Approach</b>	<b>46</b>
4.1	Modelling and Simulation . . . . .	46
4.1.1	General Model Description . . . . .	52
4.2	Simulation Robustness . . . . .	55
4.3	Simulation Results . . . . .	56

<b>5</b>	<b>Business Model for Our System</b>	<b>58</b>
5.1	Business Model Framework . . . . .	58
5.1.1	Business Model Framework for the Internet of Things Driver Monitoring System . . . . .	59
5.2	IoT Based System as a Cost-Effectiveness Solution . . . . .	68
5.2.1	Costs . . . . .	68
5.2.2	Revenue . . . . .	68
5.2.3	Cost-Benefit Analysis . . . . .	69
<b>6</b>	<b>Conclusions and Future Work</b>	<b>74</b>
	<b>References</b>	<b>77</b>

# List of Tables

3.1	Types of Errors that Lead to Deadly Accidents . . . . .	40
3.2	Types of Behavioural Mistakes that Lead to Deadly Accidents . . . . .	41
3.3	Methods Protocols . . . . .	42
5.1	Cost-Benefit Analysis . . . . .	71
1	Driver Monitoring for Economic and Social Purposes . . . . .	86
2	Driver Monitoring Systems for Environmental Purposes . . . . .	86
3	IoT Literature Review . . . . .	86

# List of Figures

2.1	Example of a Business Model Framework [33]	31
3.1	Overall System Architecture [66]	37
3.2	Data Flow	38
4.1	Overall System Modelling and Simulation	47
4.2	Sensor1 Logic	48
4.3	Sensor2 Logic	48
4.4	Sensor3 Logic	49
4.5	System Response Time	50
4.6	System Response	51
4.7	Central Database	52
1	Data Collection Table 1	87
2	Data Collection Table 2	87
3	Data Collection Table 3	88
4	Data Collection Table 4	88
5	Data Collection Table 5	88
6	Data Collection Table 6	89
7	IoT Application Costs	89
8	Average Sensor Costs [60]	89

# Chapter 1

## Introduction

This thesis studies Business Models (BM) for Internet of Things (IoT) system in the context of fleet management. We simulate out propose solution to check its applicability and then analysed different types of business models. Based on our analysis, we built a sustainable innovative business model.

### 1.1 Motivations

The evolution of the Internet from connecting personal computers to connecting human and finally connecting everything has brought with it many opportunities for businesses. The new range of Internet connectivity to connect objects that were not designed to be connected is called Internet of Things (IoT). IoT has leveraged new fusion of applications and solutions providing many advantages include huge amount of data. Also with smooth data accessibility and easy connectivity facilitate the birth of smart cities, smart governments, and smart transportation and so on. Further, it help companies to do works that were costly or impossible to do such as monitoring and tracking.

The triumph of a new technology requires both markets and businesses recognition not the success of the technology itself only. IoT adoption by businesses can most probably bring enormous benefits such as cost reduction, operation efficiency. However, businesses also can mix between IoT and machine-to-machine (M2M) or other similar technologies,

which may challenge the integrating of IoT to their processes and replace their contemporary solutions. Predominantly, when most researchers are spending their times in technical sides of IoT and few taking care of business sides. There is a great need to build BM for IoT applications to help companies clearly recognize their Return on Investment (RoI).

Fleet companies can implement IoT solutions to solve their problems and improve their performance. Having a BM as a road map for fleet businesses to implement IoT is mandatory to help them make investment's decision. Due to nature of fleet's problems and needs we would like to take IoT as an opportunity to help them do better. For that, we are proposing an IoT based solution to monitor fleet drivers to ensure safety and safe money. In addition to that, we would like to contribute to the body of knowledge of BM for this novel IoT solution.

## 1.2 Problems

Fleet management is complicated type of management. It consists of different numbers of complex tasks that are essential for businesses sustainability. Also, the nature of work in fleet businesses is completely different than other works. In fleet operations, drivers usually control on fleet operations not their managers which may threaten operations productivity and efficiency. This may aggravate other serious issues that fleet have already suffered of such as high operational cost and safety. Fleets drivers can have tremendous effect on fleet's unnecessary cost reduction by adopting a responsible driving behaviour and considering safety. The US Department of Transportation [21] believes that drivers are the key to reduced fuel consumption through monitoring of idling and bad driving habits.

Additionally, fleet businesses are struggling with finding ways to increase their profit since expanding their operations is related to increase their operational costs. In order to solve such entangled challenge their is a great need to an economic system with an ability to perform several functions and ability also to add a value not extra costs. For that we decide to use the technology of Internet of Things (IoT) to help in improving fleet performance and utilizing this solution to generate new revenue streams.

The other issue we might encounter, is that there is a lack in the number of business models for IoT. There is a dire need for BM by fleet businesses to help them trust such a technology and help them make an investment decision. BM is also important to let them figure out the cost of implementing such a system, all possible ways of saving money and also all possible opportunities of generating profits.

## 1.3 Methodology

In this thesis, we build a business model for an IoT system, we first identify problems with fleet companies in order to solve it using the IoT. After finding the problems that mentioned before, we analysed the previous systems proposed to solve the same problems. We simulated our IoT solution in Matlab to proof our concept and validate our proposed solution and to generate artificial data to be used in the BM part. Finally, we analysed the current landscape of business models for IoT and we chose our framework components.

## 1.4 Contribution

This thesis provides the following contributions:

1. We simulated an IoT system to monitor fleet's performance mainly focusing on fleet's drivers. The system have variety of sensors to do specific tasks.
2. We simulated our proposed system using MATLAB environment to proof that our proposed system is working. The result of the simulation showed an improvement in the performance by 7 percent.
3. We contributed to the body of knowledge for Business Models for IoT by building an innovation sustainable business model.
4. We create showcases on how businesses can save money and create revenue by implementing IoT solution.

## 1.5 Thesis Organization

This thesis has been organized as follows: **Chapter 2** provides the background information and researches related to fleet logistics and fleet management with the current fleet logistics and management systems. Then, it present the Internet of Things and both current and potential IoT application. Finally, it provides background information about business models and business model building blocks. **Chapter 3** presents the proposed approach to contribute in this thesis. First by simulating an IoT solution and generate some artificial data to be used in the proposed BM. **Chapter 4** presents the modelling and simulation result for our system. **Chapter 5** presents the Business Model framework and cost-benefit analysis. Finally, **Chapter 6** presents the conclusions and our vision for future research.

# Chapter 2

## Background and Related Work

Freight Transportation (FT) is an essential set of activities required for organizational success [19]. Through the contribution to the success of individual businesses, FT affects the economy of the entire country. There are different types of freight transportation, including land and air, to numerous destinations in order to achieve one common goal which is revenue generation.

### 2.1 Fleet Logistics

Logistics is defined by the Council of Supply Chain Management Professional (CSCMP) in [17] as "a function of supply chain management which is responsible for a set of activities including storing and transporting products. A well-managed FT system is a high-priority for logistics and the supply chain in general.

Logistics management is a component of the supply chain that consists of numerous complex tasks such as fleet management, network design, inventory management, and supply-demand planning and scheduling. As we can see from its definition, logistics involves all the detailed processes and operations from the creation of products until the transportation to final users.

### **2.1.1 Transportation Information Systems (TIS)**

According to a business dictionary [14] information systems are defined as systems which utilize hardware, software and infrastructure to plan, control and help businesses make the most accurate decisions based on the information available. These systems have been used in various fields for diverse purposes.

There is a great number of Transportation Information Systems (TIS) for both public and commercial transportation. Many public sector systems have been utilized by public transportations users in order to plan their trips ahead of time and to obtain necessary information such as the time, availability, and destination of buses [52].

Intel created the Tranwiseway [42] solution for commercial fleet operators, which allows them to monitor and manage their vehicles remotely using technological advances. Improved efficiency, ease of use, user acceptance, improved accuracy and reliability, and improved safety are some of the key benefits of this system. This system is one of the most remarkable solutions in terms of Intelligent Transportation Systems (ITS).

## **2.2 Fleet Management**

[30] defines Fleet Management (FM) as a function that enables businesses to remove or minimize the risks associated with their vehicle investments, improving efficiency and productivity, reducing their overall transportation and staffing costs, and ensuring compliance with policies. The following six primary fleet Management functions need to be conducted perfectly in order to ensure operational efficiency, cost control, and profits: operational fleet monitoring and management, vehicle dispatch, driver scheduling, assets trucking, condition based maintenance, and security and safety management.

### **2.2.1 Fleet Management Areas**

Fleet management consists of several subsections that are directly or indirectly related to one another. These include vehicle management, driver management, maintenance man-

agement, and safety and risk management. There are a number of fleet management solutions that can be adopted by fleet companies in order to automate their positions, however, the majority of proposed solutions only focus on vehicle location tracking. Because of the increased interest in these solutions, new features are being added and more systems are being developed.

Fleet systems have been used to provide very basic services such as planning and scheduling, as well as more complex tasks in the most effective and efficient way possible. Those systems are created to eliminate, reduce, and control problems faced by fleet companies. These problems can be very costly to fleet owners, in term of both money and reputation. Productivity and expenses are some of the areas that motivate fleet companies to seek new solutions.

Information technologies, communications, and telematics have been utilized in this industry to facilitate their work, earn more profit and reduce expenses. Many processes have been completely automated using ITS and TIS and some advanced assistance systems have been added by car and truck manufacturers.

Further, there are two types of fleet management which are: in house and outsourced fleet management. In house fleet management is happen when a business wants to have total control over their operations while they outsourced their fleet management when they want to focus on their core business [67].

## **2.2.2 Fleet Management Problems**

### **Ensuring Operational Efficiency and Productivity**

Global Positioning Systems (GPS) and Global System for Mobile communications (GSM) are one of the great innovations that have been used widely in the trucking industry as tracking systems. A tracking system is a system that uses GPS or GSM to track people or assets. These two technologies, as well as other telematics, have provided many advantages by allowing fleet administrators to keep a closer eye on their vehicles.

A large number of companies have invested in GPS technologies and upgraded other fleet management system technologies. Moreover, some companies have used a GPS in the driver's smart phone instead of the truck itself [53]. This technology can help increase fleet productivity and reduce fleet costs, which are the two main objectives of most businesses. Most importantly, fleet managers use GPS data to avoid extra time spent on work and increase driver accountability by reducing idling and unnecessary stops.

## 1. Planning and Routing

Planning and routing are the most cumbersome parts of transportation and logistics and their core concern. Although a number of solutions involving the use of different algorithms have been developed, planning and routing remain a trial for any fleet company. The primary objective of planning and routing is to ensure operational efficiency while minimizing overall cost. Planning failures can lead to increased inventory costs and not meeting client demands.

## High Operational Costs

According to the American Transportation Research Institute (ATRI) [71], fuel, vehicles, insurance, maintenance and drivers are the primary costs of any fleet. Some of these costs are fixed, but a large portion of operational costs are fluctuating and affected by different factors such as fluctuations in oil prices. Here is a list of each of the fleet costs:

1. **Fuel** has gained specific attention over the years due to its economic and environmental impacts. Researchers from different fields have tried to come up with systems or alternatives to lower energy consumption. Technological advances have helped fleet managers reduce energy usage, reducing emissions and the operational costs of the fleet industry.

Fuel consumption has been defined [37] as "the total quantity of fuel consumed by a vehicle, or specified segment of the vehicle fleet, in a road network in a specified area and time period." Many technologies have been developed to optimize fuel usage.

The authors of [39] proposed the use of a digital map and Driver Assistance System (ADAS) to let drivers anticipate the road geometry and adapted their behaviour accordingly, resulting in reduced fuel consumption.

Some driver actions or bad habits such as speeding, aggressive acceleration and braking may increase fuel consumption and expenses. Speed is defined in [37] as "The rate of change of distance with respect to time. A number of studies on the relationship between fuel consumption and going over/or under speed have been conducted. Driving style can be a good dimension to help with fuel economy.

Idling is another example of an action that has an economic and environmental impact. Idling refers to the time the engine is turned on without any real vehicle movement [68]. Idling can be very costly for both the truck industry and societies. A study conducted by the U.S Department of Transportation found that, in 2004, truck drivers idled for a total of about two hundred and forty three million hours, which is equivalent to seventeen years of work and about eight billion U.S dollar [38]. It is clear that idling can reduce productivity, produce more emissions, and increase expenses.

2. **Driver** Driver salary represents approximately twenty-six percent of a fleets total operational costs [61]. Drivers are paid per mile or per hour. There are also many hidden expenditures fleets may incur as a result of driver actions such as driving style. Risky drivers, for instance, may cause accidents, costing businesses a lot of money and damaging their reputation. According to the National Highway traffic safety Administration (NHTSA) [27], there were approximately 13.6 million commercial motor accidents in 2010, causing injury to 3.9 million people and 32.999 deaths.
3. **Insurance Premium** Insurance is defined in [43] as " coverage presented by a policy, in which an individual or entity receives financial protection or reimbursement against losses from an insurance company." The insurance industry is broad and insurance companies provide different types of insurance based on business needs and requirements [18]. The intent is to protect customers from any financial loss during operations.

There are two well-known insurance types for fleets: Usage Based Insurance (UBI) and Pay As You Drive (PAYD). The primary goal of this insurance is to enhance driver behaviours and reduce the risks associated with them [15]. This is due to the fact that 93 percent of accidents are caused by faulty decision-making on the part of drivers [70].

4. Repair and Maintenance R & M Maintenance is important in order to ensure the maximum efficiency and productivity of a fleet. It prevents operational interruptions due to vehicle failures, which may affect different interested stakeholders and increase the costs incurred by businesses. Repair and maintenance costs have increased over the past few years and now represent ten percent of the total average marginal cost for the trucking industry in the USA [72].

An analysis of overall fleet expenditures indicates that controlling driver behaviour may be an effective cost reduction tool.

## **Safety Challenges**

Although there are a number of systems available to improve the safety of commercial vehicles, behaviour-related issues are still challenging concerns [9][62]. It is for this reason that many researchers have been working on finding solutions to deal with this issue. Many researchers focus on the consequences of high-risk driving while some researchers only focus on the causes of the problem, aiming to solve it from its root. The integration of the Advanced Driver Assistance System (ADAS) and On-Board Safety Monitoring Systems (OBSMS) in fleet vehicles, as part of a Safety Management System (SMS) is a widely used method of increasing fleet safety.

The most important features of any monitoring system are the availability of a video camera and the ability to provide real-time feedback. The integration of the previously mentioned elements in the OBSMS is required for efficiency and functionality. In-vehicle video recording will enable fleet owners to observe their drivers and measure the safety

outcomes of their operations [40]. Some of the in-vehicle monitoring systems also allow the administrators to observe the environment around the driver.

## **Importance of Safety Management**

Safety management is necessary for all enterprises, regardless of their operation type. Having a good safety management may help them in ensuring corporations economic, social, environmental responsibilities [45].

Driver attitudes, behaviours and performance must meet specific criteria to satisfy fleet safety requirements. Many studies have shown that monitoring these elements of the business allows companies to measure the well-being of the fleet and to find ways to increase driver knowledge and safety awareness and reduce the percentage of crash involvement. Driving is the main cause of death in many countries such as Australia [55].

While many driver behaviours increase the percentage of collision risk, the NHTSA highlights six driver actions. These actions are driving under the influence of alcohol, driving under the influence of drugs, violating speed limits and seat belt laws, driving while drowsy or tired, and distracted driving. The NHTSA has made it their top priority to educate drivers about these risks in order to decrease the percentage of collisions and improve quality of life.

## **Cost of Vehicle Accidents**

Accidents involve economic, social and environmental costs. A single accident can be extremely expensive for a fleet company as they incur repair, delay, rent, liability and damage of property (DOP) costs. The insurance premium for the entire fleet is also at risk of increasing.

The societal impact of vehicular accidents is tremendous, causing a large number of injuries and deaths each year. According to statistics provided by the NHTSA, there was an upward trend in the number of fatalities in the first half of 2016 compared to the first half of 2015. There are both tangible and intangible costs of accidents. The tangible costs

include health care costs, loss of work and productivity, and liability. The intangible costs include decreased quality of life due to physical disabilities and psychological trauma [7].

There are also many environmental consequences of vehicular accidents. The simplest consequence is road congestion or traffic jams. While this may seem like a small, isolated event, the impact on the environment is considerable [56]. Congestion means slower vehicle movement and increased idling time, leading to more fuel consumption and air pollution.

While the severity, frequency, and economic consequences of small vehicle collisions are not precisely the same as trucks, the causes are often the same. Driver inattention is one of the primary causes of accidents.

## **2.3 Current Logistics and Fleet Systems**

It is clear from the information presented in the previous section that high operational costs and safety related concerns are major dilemmas for any fleet enterprise. Driver behaviour monitoring can be used to reduce costs and ensure safety. This section covers the current safety systems that have been used in the same or similar contexts. The technology used and strengths and weaknesses of each system will be discussed.

### **2.3.1 Safety Systems that are based on Driver's Monitoring for Economic and Social Purposes**

Because human behaviour is a major cause of accidents in transportation by land, this study [54] was developed to enhance transportation safety using a combination approaches. This system contains three subsystems: 1) human, 2) truck, and environment.

The system architecture included a combination of on-board elements and integral elements. The main On-Board Diagnostic (OBD) components were able to detect any abnormal value based on the selected parameters and send a message to the central system to be stored in the database. Each system (environment, driver, truck) included monitoring

units to collect the designated data and compare the current status with the normal (pre-defined) status. The driver system required biometric data which were obtained using a wellness system that was integrated into the system and wearable wireless sensors. The sensors acquired driver Heart Rate (HR), Breathing Rate (BR), Posture and movement.

The Heart Rate (HR) and Breathing Rate (BR) data were sent via Bluetooth to a pre-processing algorithm called SEW3, which then generated other datasets such as Heart Rate Variability (HRV). The vehicle system was used to monitor driver behaviour parameters. Two types of monitoring units were used, one for the real-time experiment and one for the simulated environment. Driver simulation software, driver location and truck simulator sensors were used in the simulation system. The primary parameters included the state of activity, alertness and the intervention of the electronic braking system. The wheel speed was also monitored. In the real-time experiment, an on-board webcam and software were used to determine the truck roadway position and distance. The results of both experiments revealed that there is a relationship between steering wheels and Heart Rate (HR) in the context of safety and driver fatigue.

The AWAKE [59] project was funded by the European Commission and consists of many integrated systems. The goal of this proposed system is to reduce the number of accidents as a result of driver hypo-vigilance and enhance safety. This system monitors the driver as well as their environment to provide the most accurate warnings and reduce false ones, increasing reliability. The data are obtained from several sources and subsystems, making the AWAKE system as robust and accurate as possible. AWAKE consists of three subsystems, each performing a specific function, in order to achieve the designed objective of the core system. Real time computations are performed in each subsystem. The first subsystem is the hypo-vigilance Diagnostic Module (HDM). This system fuses data from several resources such as an artificial intelligence algorithm and on-board sensors to monitor driver status, driver behaviour and physiological data.

The second subsystem is the Traffic Risk Estimation (TRE). This system matches data from several sources, including on-board vehicle sensors (e.g. speed and steering angle), surrounding sensors (e.g. front radar, GPS localization), gaze detection and environmental

sensors (e.g. temperature, light). The goal of this subsystem is to link the warning system with the surrounding environment to improve the ability of the system to assess driver vigilance and reduce false alarms. Frontal Collision Warning (FCW), Lane Warning (LW) and Curve Warning (CVW) are examples of warnings generated by this subsystem.

The last and most important subsystem is the Driver Warning System (DWS), which provides the driver with different levels and types of warnings based on data received by the Hierarchical Manager (HM). The driver receives warnings using the Human Machine Interface (HMI). The HM is a gateway to exchange data between different subsystems. The overall system is comprehensive and expected to detect driver fatigue in the most accurate and reliable ways due to the use of several technologies.

The Copilot [34] project is a cost effective system used to predict driver drowsiness based on the PERCLOS concept in order to reduce the number of accidents caused by commercial vehicles. PERCLOS is defined as "the proportion of eyelid closure over a period of time." Simulator experiments revealed that operator performance was enhanced when they received feedback. An improvement was therefore made to the driver interface.

The warnings are based on computations conducted by PERCLOS every three minutes. This video-based system consists of one camera with the ability capture any head movement and the driver interface which includes a visual gauge and an audible tone to provide feedback and warning.

In the feedback simulation, voice warnings were provided with buzzer alerts based on the level of fatigue. Copilot is considered one of the best solutions to identify driver fatigue and identify the best time for a break. Meeting driver needs will increase their productivity and improve their performance.

This study is designed to solve driver's distraction is determined as one of the chronic problems in transportation that cause about 50 percent of accidents rate. Crashes can lead to the enormous number of fatalities, many researches have taking place to avoid crashes or at least minimize their severity. In this study the author tries to study ways to mitigate driving distraction, with existence of in-vehicle information system, by providing different types of feedback, which include post-trip and concurrent feedback.

Driver distraction is a serious transportation problem that is responsible for approximately 50 percent of all driving accidents. Driving accidents can lead to an enormous number of fatalities. As a result, many researchers have been looking for ways to avoid them or at least minimize their severity. In this study, the author attempted to mitigate driving distraction with the existence of an in-vehicle information system, by providing different types of feedback including post-trip and concurrent.

This study [25] was conducted using a driving simulator and three different conditions: 1) no feedback given to the driver, 2) combined feedback (retrospective and concurrent), and 3) retrospective feedback. The main goal of this study was to focus on combined and retrospective feedback as there were not enough studies investigating retrospective feedback. A FaceLabe eye tracker was used in this study to know where the driver is looking in real-time. A display screen was also available on the dashboard to present visible messages.

The authors in [69] developed an in-vehicle data recorder system to improve traffic safety by eliminating unsafe driving manoeuvres and reducing accidents. Two types of on-board recorders were used: 1) an Accident Data Recorder (ADR) and 2) a Journey Data Recorder (JDR). The first recorder collects data shortly before and during the accident and the second one collects data regarding speed and scheduling, which are indirectly related to driver performance. While their system only reduced the accident rate by 20 percent, the authors shared the results of their system due to the type of feedback used.

The authors of this study [50] aimed to develop an on-line monitoring system to identify driver fatigue. The primary motivation of this study was to improve the existing accident prevention systems by assessing levels of alertness, as it is one of the main causes of vehicular accidents.

In order to improve the accuracy and reliability of this method, multiple physiological signals should be recorded [50]. Five physiological signals were collected during the simulation experiment. These were heart rate, skin conduction, electromyogram, skin temperature and respiration. Following data collection, the researchers use wavelet and fuzzy cluster analysis to develop the identification algorithm. In addition, video images of the

driver's face were used to identify the physical signals of fatigue and match them with the physiological signals. This method was able to successfully detect the various states of driver alertness (alert, translational phase, fatigue). According to the authors, this method requires further development. They suggest the use of the electromyogram (EEG) as it has a powerful ability to provide a reliable signal to assess the level of driver alertness.

Fleet managers require accurate information about vehicle usage, which differs from one vehicle to another according to driving style. Researchers propose SenseFleet [16], a driver profile platform that is able to detect risky driving events from a mobile device and the vehicle independently. This system benefits fleet administrators as well as other interested parties such as insurance companies.

The fuzzy logic system was used in this system to evaluate driver performance based on real-time information. This system takes into account the weather and route conditions and other real-time variables. The system contains telematics boxes to gather sensing data. All of the information about driver performance is then manually retrieved over the Internet. The SenseFleet system has shown the ability to accurately detect risky driving, providing a score for each driver.

### **2.3.2 Safety Systems Designed for Environmental Purposes**

Transportation involves the consumption of a vast quantity of fuel and accounts for about a third of Carbon Dioxide CO<sub>2</sub> emissions in the US. Furthermore, there is no doubt that freight transportation is one of the primary causes of increases in GHGs. These factors contribute to high operational costs for fleet companies as well as climate change. Many strategies and technologies have been proposed and implemented to lower fuel consumption and emissions. These include alternative fuels, the eco-driving concept, and reduced vehicle speeds. In this section we will explore a list of systems that aim to reduce fuel consumption via the vehicle's operators.

The authors in [39] propose an Ecological Driver Assistance System (EDAS). The primary motivations for this work are to help the environment by reducing CO<sub>2</sub>, to reduce

costs by lowering fuel consumption, and to help society by increasing driver safety and reducing road stress. This system uses information from digital maps to predict the upcoming action and a Human Machine Interface (HMI) to support the driver with the necessary recommendations. The effectiveness of the system is based on 4 subjective and objective parameters using 3 EDAS configurations.

The performance criteria were economy, safety, comfort, and acceptance. The 3 configurations were the series acceleration pedal, the haptic acceleration pedal, and the graphical dashboard. Furthermore, because this solution is a control system, human (truck driver) is located in the control loop, which would be considered as difficulty. The system was tested in a real life situation using a semi-trailer carrying 30 ton gross weight and travelling 34 kms. The results of this study revealed that truck drivers are willing to reduce fuel consumption if they are provided with EDAS. The results also revealed that the haptic acceleration provided the best results. The mood of recommendation (feedback) in this system is different from one configuration to another. For instance, in the hepatic acceleration, the vibration mood was used for coasting recommendations.

The authors of [5] proposed a system based on the determination of the vehicle's speed and acceleration in order to reduce fuel consumption and emissions. Eco-driving was defined by [3] as "an energy-efficient use of vehicles that is based on the decisions and behaviours adopted by drivers." The system was built using an Intelligent Speed Adaptation (ISA) theme and consists of two subsystems: speed determination and traffic data collection. The main system used a variety of technologies such as GPS. The system works by adjusting the speed of the vehicle during the trip; different location and traffic conditions required different speeds.

To ensure the efficiency of the system, two unique simulation and modelling tools (PARMICS and SMEM) were used to conduct different scenarios under different conditions. Once the simulations were successful, real time experiments were conducted.

The authors in [3] gathered on-road speed, fuel consumption and emission data from four vehicles equipped with data collection instruments in four driving modes inside cities. The results revealed that fuel-based emissions varied more than time and distance based

emissions. The results also revealed that the transitory driving modes, which include acceleration and deceleration, contributed more to air pollution than steady speed driving modes such as idling. See Appendix 6.

## 2.4 The Internet of Things

The Internet has the ability to evolve, expand and grow over time. The fast expansion of the Internet and information technologies has increased the need for the development of new accessible and affordable concepts and technologies in order to cope with the needs of users. These technologies can be used to find solutions to existing problems or to enhance businesses. The Internet of Things (IoT) is one of these concepts. Although it is still under development, it has shown great success.

### 2.4.1 IoT Definitions

The Internet of Things (IoT) is a technological revolution that enables interaction between objects, people and environments. With the advent of IoT, physical objects are becoming smarter than before. This has changed the way we live by improving sustainability, efficiency, accuracy and economy in almost every aspect of our lives. IoT has been leveraged in many industries including healthcare systems, traffic management, energy management, education, environment monitoring, and smart homes [4].

There are a large number of IoT definitions that stem from the same concept. The basic concept of the IoT is that physical objects are connecting to the Internet and communicating with each other to perform specific functions. Here are some of the IoT definitions that have been mentioned in the literature:

1. in [77], IoT is defined as the ability to provide Internet connectivity to all of the objects around us in order for anyone to be able to access to the information anytime and anywhere.

2. in [64], IoT is defined as the provision of internet coverage to all objects (making objects smart) in order to access real-time information.
3. in [75], IoT is defined by The International Telecommunication Union (ITU) and European Research Cluster (IERC) as a dynamic network infrastructure with self-configuring capabilities.
4. in [64], [79], and [81], the authors defined IoT as the wide presence of smart gadgets (e.g. sensors) that are designed to interact and communicate with each other for specific purposes.

A number of research studies and surveys have been developed since IoT is considered a beneficial upward trend. A study conducted in China in 2009 revealed that the Internet growth rate doubles each 5 or 6 years [28]. The massive increase in the number of devices connected to the Internet has reinforced the concept of the IoT. Surveys have revealed that the number of devices on the Internet in 2010 was 12.5 billion, while world population in the same year was 6.8 billion. There is no doubt that these numbers will continue to rise. In fact, they are expected to reach 50 billion by 2020 [28] while the world population is estimated to be 7.6 billion. This explosive number of connected devices compared to the steady increase in the world population is considered an indicator of an IoT future.

## 2.4.2 IoT Components

Sensors, middle ware, and actuators are three of the major enabling technologies for the Internet of Things. The markets for these technologies have changed, which facilitates the vast deployment of IoT, affecting the way we communicate and live and the ways corporations work and generate revenue. The ability of physical objects to connect to the internet and communicate with each other may also lead to the creation of other unexpected applications.

Sensing and Communication Technologies is the first block of the Internet of Things [73] and is comprised of Wireless Sensor Networks (WSN) and Radio Frequency Identification (RFID). RFID is a technology which automatically identifies and tracks objects

using electromagnetic fields and embedded technologies such as tags. These embedded technologies can be active or passive.

One of the significant advantages of RFID is its limited cost, making it extremely valuable to identify and track a large number of objects in IoT [35]. Some of the shortcomings of RFID include security, privacy, and energy limitations [73]. Library Systems, Real time location, and logistics and supply chain are some examples of RFID applications.

The Wireless Sensor Network is the second component of the first IoT block. WSN can be incorporated into RFID to enhance the performance and quality of the work. WSN can be seen as the bridge between the physical and digital worlds. The data generated is easily collected using context-dependent sensors.

The specific features of sensors are critical in regards to helping businesses collect information in order to increase operational efficiency, find solutions to common problems, search for profit opportunities and reduce costs. The low cost of sensors is their main advantage while scalability, robustness, and reliability are their major constraints [73]. Some interesting WSN applications include predictive maintenance, enhancing safety and security, and reducing CO<sub>2</sub> emissions.

The second and third blocks of IoT are the Middle-ware and Actuating Blocks. Middle-ware is responsible for the connectivity between both sensors and between the layers themselves. Middle-ware provides a wall that is required to hide the complex parts and operations in the lower layers.

### **Importance of IoT for Businesses**

Due to the fact that the virtual communications becoming increasingly possible because of the Internet, new creations and innovations have been created to cope with this revolution. IoT is one of them but it has many strength points over the other technologies or the internet itself. The concept of the IoT is very powerful and fair enough to be in the consideration of researchers, businesses, markets and industries.

IoT application consist of RFID, senseors, actuators, embedded software and smart-

phone [63]. These components feature the IoT to be a self-configuration and more adaptive system [11]. The enormous sensors deployed on the IoT with communications technologies like wireless communication, which includes Bluetooth, WI-FI, 4G/3G, will have the ability to interact with each other using unique address scheme [36][11].

IoT is moving from just an idea to a product in a fast way. Five components help in this fast evolution of IoT and to overcome its defined challenges. Those components are standard developments, national research centres, service providers, network operators, and the lead users as they expressed by ITU [35] and working concurrently to push IoT forward.

This quick changes in IoT R & D should convince business to implement IoT solutions and applications in their work to gain many advantages rather than applying the wait and see strategy. Moreover, IoT will enable firms to be pioneer in their industry by embracing IoT. One biggest feature of the IoT is that this technology can be structured and build based on the purpose, and the opportunities behind it can be captured based on businesses needs and companies value chain [65]. Future Internet or IoT is the coming generation of the Internet. It considered the most cost effective solution compared to the value giving. Many markets response to the transition of the Internet toward the new version of it. Sensor market, for example, has complied to the IoT requirement and gain by producing new forms of sensors that fit with IoT needs and reducing sensors prices. In addition to that IoT will help in improving the value chain for business through two ways.

First way, increase the income and create new opportunities. The second one, help in ensuring the smooth connection between all interested parties such as producer, buyer and seller [Farmer and IoT]. Forty percent of businesses leaders think that IoT will have a impact on limited number of markets [20], but it can be clearly seen that all of the markets will be controlled and impacted by IoT with different degrees. For instance, manufactures, and healthcare are expected to adopt IoT by sixteen percent, while agriculture will be impacted by IoT by 4 percent [63]. Thus, IoT transforming physical things to a smart and intelligent entity with ability to sense, listen, take, share information and most importantly think and perform tasks with no chance of mistakes [63], which will be very valuable for all businesses

and industries.

The major fields that are compete in using IoT applications are:

- Transportation: smart traffic, automatically driven vehicle, intelligent transportation and logistic, dynamic monitoring systems
- Home and personal: smart home, smart coffee makers, smart applicants
- Health: smart hospital, smart sensors in health care, smart monitoring tools

### **2.4.3 Current and Potential IoT Applications**

IoT applications are continuing to expand in markets. See appendix for some of the current and potential application [3](#)

#### **An Internet of Things based Intelligent Transportation System**

This system [78] is designed for public transportation to monitor the location of the bus, the passengers within the bus, and the atmosphere inside the bus and is composed of three subsystems. The fist subsystem is the Sensor System, which consists of three components: GPS, NFC, and humidity and temperature sensors. The GPS is used to track the location of the bus, the NFC is used to track passengers (number and destination, name of stops, and ticket payment), and the humidity and temperature sensors are used to monitor the atmosphere inside the bus. All of the components in the system are connected to the Internet using GSM.

The second subsystem extracts the raw data from the sensors, stores it in SQL databases, converts it into useful information and sends it to the driver. It is also used to notify drivers about specific events. The last subsystem consists of an LCD screen at every bus stop, using the information produced by the monitoring system and displaying it for people who are waiting for the bus. The display information includes the waiting time and the location of the bus.

## **Internet of Things Based Systems for Food Safety Management**

This system [24] is designed to analyse food production related activities in order to generate data for different purposes. First, the data generated by the system is used to improve organizational management as well as the quality of services provided to customers. Second, RFID/NFC tags are embedded in different locations such as vehicles and supermarkets, allowing consumers to track the food from its origin to the final destination. These tags also allow drivers to find the best route for the vehicle based on food conditions. The system collects data using smart objects such as sensors.

## **Internet of Things Based 3D Assisted Driving System for Trucks in Mines**

This system [66] is designed to assist truck drivers in mines by providing a 3D view, which will help reduce the rate of accidents caused by blind spots and a lack of clear visibility. The system is considered an Assisted Driving System (ADS) and the information provided to the driver is based on real-time data. The application has three main layers: sensors, network and application. The sensors collect all of the required data, the network is responsible for communication and routing the data, and the application (the cloud computing layer) processes and stores all of the data.

## **A Low Cost Internet of Things Solution for Traceability and Monitoring Food Safety During Transportation**

This application [49] uses the IoT to build a low cost solution that aims to reduce the health hazard caused by food contamination. The system monitors perishable items during transportation using many sensors, including temperature, humidity, carbon dioxide, and heavy metal sensors. Any problem with the food triggers the system to send a real-time alert. The system also provides information about items that have been shipped using RFID/ NFC or Bluetooth. Raspberry Pi (RPi) can be placed in every container as a processing unit, making this solution more universal.

## Intelligent Transportation based on the Internet of Things

This system was designed by [78] to enhance ITS based on the IoT for public transportation using technologies such as RFID, GPS, GPRS, and GIS. The primary goal of this system is to help societies improve their public transportation systems by gathering information about buses and their users. The system includes multiple subsystems, each one performing a unique function. The main subsystems include the vehicle and station subsystem and the ITS monitoring centre. The vehicle and station subsystem receives and collects data while the ITS monitoring centre acts as a control unit.

## 2.5 Business Model

Business Model (BM) is a buzzword that has gained the attention of scholars and practitioners, especially since the birth of the Internet. The lack of a unified definition of BM has contributed to terminology confusion, particularly between BM and business strategy. There is no doubt that Business Model and other managerial concepts are interrelated, which is another important factor in this confusion. In order to build a solid and competitive BM, it is important to examine its definition in order to have a clear understanding of the concept.

Business models are required by companies in order to depict their path to success. Business models provide information about core business activities and plans to generate revenue or create new revenue streams. Companies must constantly review and change their BM in order to avoid falling behind in their market.

### 2.5.1 Definition Analysis

Business models are usually defined based on a particular area of interest and are required in order to justify investments. The first common interest area is the use of Information Technology and E-business, followed by interest in strategic issues such as competitive advantages, and interest in innovation and management of technology [82].

While there is no universal definition of the term business model, there are some common words used to describe it including an architecture, design, pattern, plan, method, assumption, and statement. Regardless of the way it is defined, most would agree that BM is a key analytical tool which tells the story of how companies create a win-to-win product or service in order to add value for itself and all of its interested stakeholders.

Timmers [82] defines Business Model as an architecture that is built for specific products, services or flow of data that defines all of the stakeholders and the function of the business and shows the possible opportunities for each of them. The business model should also explain how this business will generate revenue from the project. Magretta [82] also defines BM as stories which explain how projects work, pointing out any interdependence and activities. These two definitions are different, but they share some main ideas.

The following is a list of some other BM definitions:

1. Mark Johnson, in his book entitled *Seizing the White Space*, defines a business model as the set of activities that a company undertakes to deliver value to their customers and earn money [44].
2. We define a company's business model as a system of interconnected and interdependent activities that determine the way a company does business with its customers, partners and vendors [2].
3. Teece [32] defines a business model as a management hypothesis of customer needs, and ways to meet those needs in order to make a profit.
4. The most common definition is that BM is a company plan or logic used to generate revenue and make profit.

In order to be able to build a comprehensive Business Model for our project, we need to understand the landscape of BM by exploring its definitions, elements, and some of the existing frameworks.

## 2.6 Current available Business Models Building Blocks

In order to develop a business model framework for our system, we decided to analyse all of the business models available for IoT applications, regardless of the field. Due to the scarcity of published papers, we expanded our search criteria to include business models for intelligent transportation systems. We used a variety of databases including web of science, Google scholar, ProQuest, Science Direct, Scopus, and Springer.

All BM frameworks consist of elements that are defined as the building blocks/ components of the system. These elements are designed to communicate and interact with one another to create and capture value for both businesses and their customers.

The most difficult part of building a business model is deciding which building blocks to choose. Business models are usually evaluated and analysed based on their definitions and classification. We chose to analyse the components of both the sustainability and innovative business models in order to build one comprehensive business model for IoT.

Following this step, we conducted an analysis of all the BMs presented in the literature in order to ensure that our business model did not lack any critical components. The results of our analysis revealed that there is a typical business model derived from Canvas BM, which has been used by researchers and practitioners [13]. This BM consists of the following elements:

1. Value Proposition: Where both quantitative (e.g. price) and qualitative (e.g. risk reduction) analysis of the solution are presented after presenting the customer and their needs.
2. Customer Perspectives: Where both the customer segments and customer relationships are mentioned. Customer Segments involves defining the different groups of people that are being served. Customers can be served through different channels (directly or indirectly). Customer Relationships are determined by the selected communication channel
3. Infrastructure Components: Where key resources, key activities, and key partners are

mentioned. Key Resources defines all the assets required to make the business model work. Key Activities describes the actions necessary to create, offer and market the value proposition. Key Partners presents all of the collaborative partners.

4. 4. Financial Perspectives: Where all financial matters are presented. Revenue and cost structures are the most important parts of this section. Revenue Structure lists all of the sources of revenue generation (asset sale, usage fees, subscription fees, landing/ renting/ leasing). Cost Structure lists all of the fixed and variable costs.

It is not necessary for the customer perspectives block to stand on its own since it will be mentioned in the value proposition block. This block can therefore be excluded. The financial perspective block is the most significant block for any business model; It helps companies determine if the solution is satisfactory for all interested parties, or if the solution is cost or value driven.

Many studies have shown that value creation and value capture are the most important elements of Innovative BMs [51]. Each of these elements are defined below:

1. Value Proposition: A company's promise to fulfil the needs of their customers and users in a different way than their rivals by offering unique products and or services. This should cover the problems encountered by customers and how to solve them using the proposed application.
2. Value Creation: The way a company creates value for itself and its customers, partners, and stakeholders.
3. Value Capture: The company's way of capturing the defined value and translating it into profit.

Other studies claim that the Innovative BM is an activity system and should include the content, structure, and governance of activities in their BMI [31].

1. Content: Refers to the selection of activities that will be conducted by the system.

2. Structure: Shows the relationship between activities.
3. Governance: Reveals who is conducting the activities.

There are four other building blocks for business model innovation presented in the literature. These building blocks show the ways in which companies can create a business model to transcend the business model of their rivals. Successful companies have specific business models to guide them; they do not operate randomly even if their business models are not documented. Some of the BMI components that have been used by many successful companies are listed below::

1. Customer Value Proposition (CVP): Defined as a company's ability to offer value that fulfills customer needs better than their competitors ;.
2. Profit Formula (PF): The ways the company generates revenue from specific processes, products, services or projects after calculating all of the capital costs;
3. Key Resources (KR) and Key Processes (KP): Key Resources (KR) and Key processes (KP) are resources and actions needed to deliver and create value. KR involves people/sensors etc., while KP involves buying/ renting/selling etc.

Based on the analysis of available components, many researchers suggest that value networks (value creation, value capture, value proposition) are the most important components of sustainable business models. **Business Models in the IoT Context** We looked at all published articles regarding business models and IoT in order to find the most common framework. Since the search did not yield any results for BM and IoT in the context of fleet management, we expanded our search criteria to include all articles with the keywords BM for IoT, regardless of the field. The main goal of this analysis was to investigate as many BM frameworks as possible to assist us in developing our framework. Our BM will add to the BM literature as it is the first one in the context of fleet management. The following is a simple review of the papers we studied and their business model frameworks and building blocks.

In [22] the authors used empirical research methodology to develop a framework for a general business model for the internet of things. The data used to develop the framework was gathered through interviews with practitioners working on IoT business models. Their framework was mainly based on the Canvas business model. The main building blocks were: key partners, key activities, key resources, customer relationships, customer segments, value proposition, channels, revenue streams, and cost structure. It is worth mentioning that the detailed building blocks are based on the views of individual practitioners and can vary based on the area in which the application will be implemented. The results revealed that value proposition, key partners and customer relations are the most important building blocks of any IoT business model.

Educational institutions could be heavily impacted by Internet of things communication due to the links between the physical and digital world and services provided by sensors. [4] investigated the changes to an Education Business Model platform based on the implementation of an IoT project. The authors investigated how IoT adds new value propositions based on Canvas. In order to determine the impact of the qualitative research they conducted, the authors conducted a literature review and then created an educational business model in order to determine the areas most impacted by IoT.

A comparison of their business model and canvas based business models revealed that all nine Canvas building blocks were changed and new value propositions were added. The new advantages of the implementation of IoT were: cost reduction, better student collaboration and engagement, and enhanced safety. This study indicates that IoT technology will have an impact on all future business models.

The authors of [29] conducted a study to investigate the impact of business models on the Postal Logistic industry. The postal logistic industry has a very complicated structure and the addition of an IoT application further complicates the structure due to the involvement of different types of businesses from different industries. The primary goal of this research was to find out how to construct a viable business model with the ability to make profit from the application of IoT.

The business model presented in this paper is quite different than others that have

been proposed. The authors developed their business model based on two dimensions: the type of business model in logistics (cooperative, self, customer and channel) and the seven areas of mixing IoT and logistics. The relationship between these areas and types impacts service flow and payment flow. For example, the service provider provides a service to the customer and the customer then makes payment to the service provider. All of the stakeholders benefited from the developed application.

Another study criticized the existing business model frameworks and the lack of connection between the various components and ignoring BM ecosystem [77]. The studies show that limiting business model frameworks to value creation and value capture is not the most ideal way of providing a well structured BM. For that, researchers try to study BM ecosystem in order to fulfill the need of value creation, innovation recognition and generate revenue. The design proposed by the author composed of business model components for the IoT ecosystem, which involve: value driver, value nodes, value extracts and value exchanges

Business model components presented in this research [76] is also considered unique compared to other BM elements. The framework also for Industrial IoT BM derived through analysing 22 BM out of 55 generic BM. These elements are:

1. Digital Add-on: representation of BM elements where digital offers are provided by physical goods.
2. Digital Lock-in: following a razor and blade business model.
3. Product as a Point of Sales: switching physical product into platforms.
4. Physical Freemium: solutions offered by physical products.
5. Object Self Service: where machines do the work of humans
6. Remote Usage and Condition Monitoring: refers to the ability of physical products to produce real time data.

### 2.6.1 Example of BM Framework

There is no unified framework for BM. Different frameworks present in different papers based on the purpose of that papers.

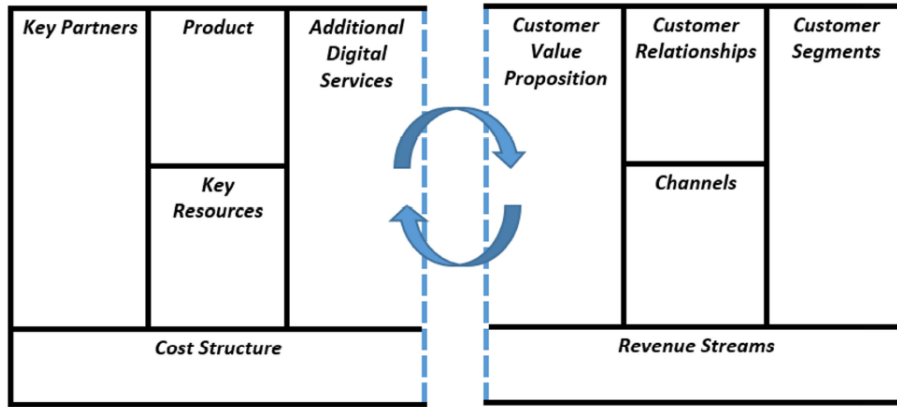

Figure 2.1: Example of a Business Model Framework [33]

This framework is called "The outcome-based business model" and is derived mainly from Canvas BM. This type of framework is used in cases where the economic outcome is very significant compared to other aspects.

### 2.6.2 Main Purpose of Building a Business Model for IoT

Business models and business model alternatives can be used by enterprises as evaluation tools to ensure their development. They can be used to provide insights about future opportunities such as a new markets in which they can operate or new products and services to be developed. Without a suitable business model for a particular project, such as the adoption of a new technology, the development process for this particular project will be slowed down.

Business models provide the logic that enterprises follow in order to earn profit and create value [32]. Business models function as a bridge between a businesses vision and strategy and essential operations, and transform ideas into revenues [32]. Technology and innovation are strongly connected with maximizing commercial value.

The majority of business models that have been designed for technology are missing important aspects related to sustainability and social impact. The best way to fix this problem is to use two business models, a sustainable business model and an innovation business model [32]. There are conflicting opinions about whether or not companies can use more than one business model for a particular project (new business, new product, new service). This question has been addressed by many researchers and the consensus is that they can [58].

Amazon developed their own on-line business model that has contributed to its success. The company offers a service to other companies, called Amazon Web, using its own unique computing power. This strategy transformed the operational cost of computing processes into a new portable product. Their well-designed business model allowed them to realize this golden opportunity.

While there are many different perspectives when building a business model for a business, product, or service, most agree that providing a value is one of the most important aspects of the business model. Value could mean generating more revenue, lowering costs, or any other business need. The majority of business models now involve a value network (captured, created, distributed, etc.). Value is not necessarily something financial. It includes any benefits that of all interested parties (company and customers) get from an enterprise (customer satisfaction is a value for customers).

### **2.6.3 Business Model Gap**

This research study aims to fill the literature gap involving business models for the Internet of Things. An analysis of the current body of knowledge revealed that there are a limited number of studies involving business models and the current generation of technologies. A lack of appropriate business models has hindered the success of some technologies. In order to avoid this issue with the Internet of Things and fleet companies, we need to build a comprehensive business model in order to help fleet companies decide whether they should invest in this technology. According to statistics released by The Economist Intelligence Unit (2013), the biggest incentive for businesses to move ahead with the IoT is the potential

financial returns from its productisation [23].

It is important to note that business models designed for other purposes may not be valid for use with IoT due to differences in nature and the fact that this is a newly developed technology. The imitation of existing models may not be the best way to convince companies to invest in this technology. The primary goal of the development of a business model for IoT is to illustrate all of the potential benefits of the adoption of this system, including financial returns. Financial return is the key to the successful application of IoT in different contexts.

The decrease in the price of information technology as well as the advantages of using these technologies increases the potential savings for fleet companies. This also helps reinforce in-house fleet management since fleet companies will have better control over all of the important fleet components such as the quality of the services provided, insurance, and accident management. A proper business model must be developed in order to show the potential impact and financial return of IoT for fleet management and the truck industry.

# Chapter 3

## Proposed Approach

This thesis proposes two different steps, each designed to achieve a particular goal. The first step is related to the monitoring of fleet performance using the IoT concept as well as the verification of the validity of our system. The second step is related to the creation of a business model for this IoT system based on the simulation results. Both of these steps are presented in this chapter.

### 3.1 First Step

In order to check the applicability of our proposed solution, we simulated the system using the modern control systems theory approach in the MATLAB environment. This method allows us to explore the system's performance without having to build it. We chose this method because we are building a closed-loop control system [26]. Modern control system consists of a set of connected objects that communicate with each other to provide feedback, mainly by utilizing sensors data.

### 3.1.1 System Description

### 3.1.2 Simulation Environment

Using Matlab and the Simulink environment, we simulated an IoT driver monitoring system using historical data to compare the current method and the IoT system. The simulation involved three devices with multiple sensors and made use of data from different sources and different years.

#### System Requirements

Before we conducted our simulation, we defined all of the potential system requirements necessary to meet client needs. The Internet of Things was chosen as a main theme to solve the aforementioned problems, maximizing the opportunities and values that the system will provide to end users. Here is a list of all the possible system requirements:

1. The ability to build an economical safety system.
2. The ability of the sensors to work reliably by detecting all of the desired and defined events that are considered safety threats.
3. The ability of the sensors to detect safety threats that are related to weather. For example, low visibility due to heavy snow.
4. The ability of the sensors to detect safety threats that are related to driver performance and behaviour. For example, violating the law by driving above the speed limit.
5. The ability of the sensors to detect safety threats that are related to problems with the vehicle. For example, vehicle engine breakdown
6. The system's ability to send alerts when the probability of an event that threatens safety is close to one (high).

7. The system's ability to send alerts when the probability of an event that threatens safety is close to zero (low).
8. The ability to minimize the occurrence of false alarms.

If we can meet and maintain the above requirements, we can reduce fuel consumption and the number of accidents, contributing to social, economic and environmental sustainability.

## System Architecture

We created a system architecture to assist with the understanding of data flow in the system. The system architecture consists of six layers derived from [66]. These layers are:

**The Perception Layer** This layer consists of sensors, actuators, and a screen that displays the Safest Driver application. The sensors communicate with each other using MQTT protocols. MQTT is the connectivity protocol for IoT to connect objects in remote locations.

**The communication Layer** This layer consists of the IoT application data gathered from sensors which needs to be processed in the smart gateways. LTE (Long-Term Evolution), a form of high-speed wireless communication, will be used as a means of communication.

**The network Layer** This layer consists of the gateway or local cloud where the data are rapidly processed. The decision is then sent directly to drivers via LTE communication. All of the data, information and decisions will be sent to the cloud.

**The cloud Layer** This layer is designed to store data, apply intelligent data analysis techniques, and generate reports (daily, weekly, monthly, or based on the end users needs).

**The application Layer** This layer is responsible for sending notifications or alarms to managers in the operation center.

**The business layer** This layer consists of the ways businesses can generate revenue from this application and exchange tier information and data with other interested parties. Parties who can purchase data may include, but are not limited to: insurance companies, research institutions, investment agencies, governments, the ministry of transportation, road safety agencies, and hospitals.

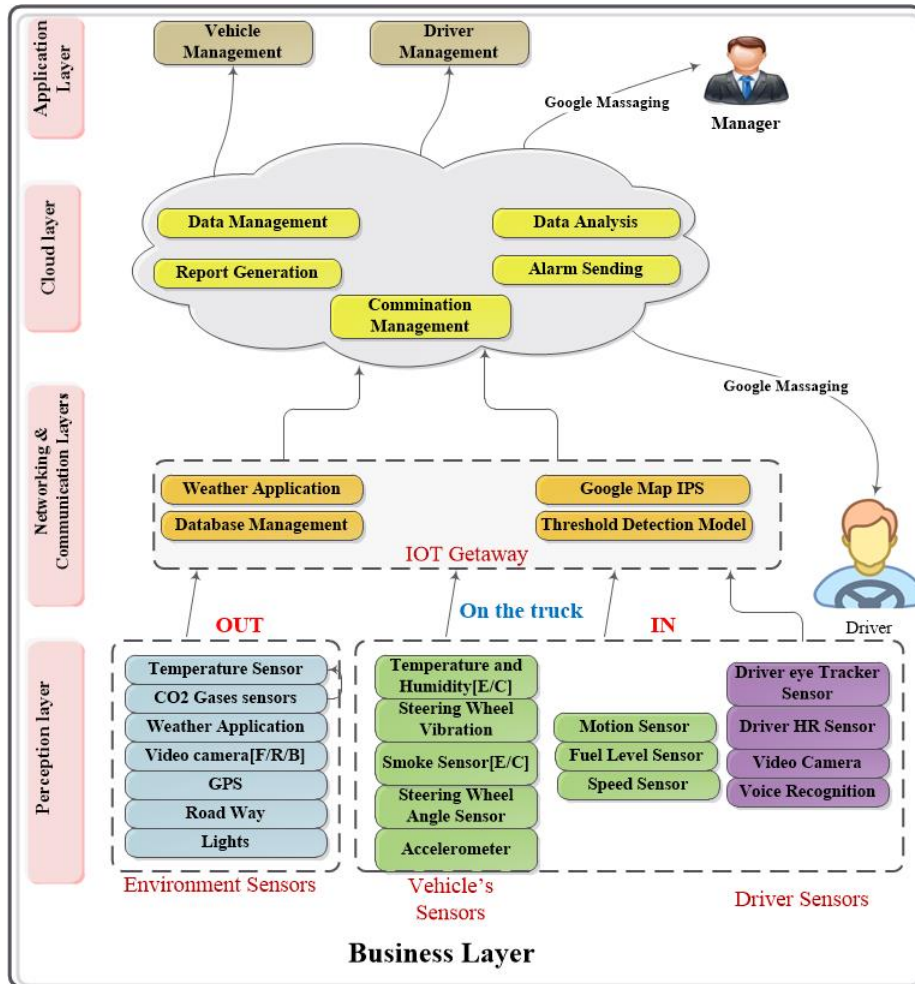

Figure 3.1: Overall System Architecture [66]

This proposed system is predictive one with an ability to send alerts and feedbacks 3.2. Alert is sent to the driver to warn him about an action (for example: to stop the aggressive acceleration) through gateways communication. While feedback can be send from the cloud after analysing and reporting the gathered data.

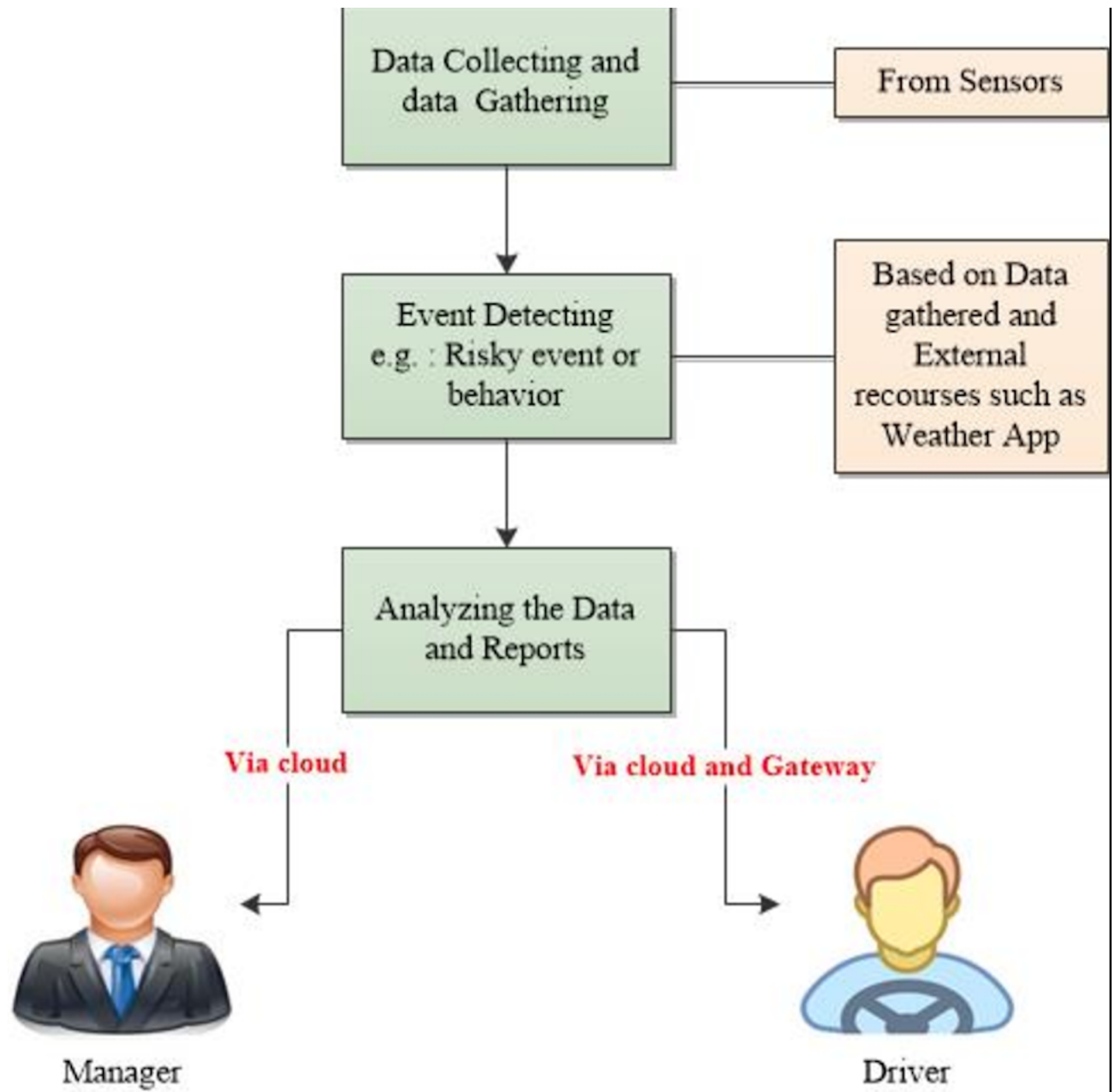

Figure 3.2: Data Flow

### 3.1.3 Data Collection and Assumptions

#### Data Collection

Two datasets were used: Dataset1 and Dataset 2. These two datasets contain driving session information collected under different circumstances. Some statistics of the two datasets

are shown in Appendix 6. The first dataset was obtained from the National Motor Vehicle Crash Causation (NMVCCS), under the US department of Transportation, DOT HS 811 059, July 2008. The second is an online source, the General statistics of Crashes in the U.S. in 2015, <http://www.iihs.org/iihs/topics/t/general-statistics/fatalityfacts/overview-of-fatality-facts>.

Dataset 1 contains the following information (variables) for each search session:

1. Crash events preceded by speed misjudgments.
2. Crash events involving driver emotional factors.
3. Roadway related factor information.
4. Statistics on the frequency of behaviours prior to crashes.
5. Data on critical pre-crash events.

The units of observation were trucks and their drivers, over a period of about 7 years. The sample sizes were large enough to allow for the usual statistical procedures. For instance, the number of vehicles observed in Dataset1 ranged from 500 to 3000. In classical statistics, a sample of size  $n > 30$  is considered large enough to provide reasonably accurate estimates of the average and the standard deviation. Some important variables (such as the distribution of occurrence of accidents) are missing from this dataset.

We made some key assumptions to estimate those missing data, which will later serve to generate artificial data. Although the study focuses on Canada, the absence of reliable sources led us to use data from the US. This could affect the estimations and conclusions if there are significant differences between the behaviour of drivers in Canada and the US. The data collection methods, codes and potential measurement errors can be found in the original source mentioned above.

## **Assumptions**

The original micro-data does not contain details about the distribution of crash fatalities due to driver behaviour. Our simulation relies on the following assumptions:

1. The frequency of crashes for each category of behaviour is constant in time (does not vary much).
2. Because of the large sample sizes, the distribution of the fatality rate with respect to the two categories (brake=2, no brake=1) is the same as the empirical frequencies.
3. The nature of the error in a fatal crash falls under one of the 13 categories in the table below. The probability of each event is estimated by the empirical count or their frequencies.

<b>Event</b>	<b>Code</b>
Vehicle Failure	1
Brakes	2
Unfamiliarity with the Road	3
Pressure Feeling	4
Fatigue	5
Tire Problems	6
Aggressive Driving	7
Driver Illness	8
Illegal Drug Use	9
Alcohol Use	10
Roadway	11
Weather	12
Others (including environment)	13

Table 3.1: Types of Errors that Lead to Deadly Accidents

4. The type of behaviours that lead to fatal crashes fall under one of the 12 categories in the table below. The probability of each event is estimated by the empirical frequencies listed in the table below:

<b>Event</b>	<b>Code</b>
Going Straight	1
Negotiate a Curve	2
Stop in Traffic Lane	3
Decelerate in traffic lane	4
Avoiding Manoeuvre	5
Changing Lanes	6
Turning Left	7
Turning Right	8
Accelerating in Traffic Lane	9
Passing Another Vehicle	10
Making a U Turn	11
Other	12

Table 3.2: Types of Behavioural Mistakes that Lead to Deadly Accidents

### **Generated Artificial Data**

With the estimated probabilities in hand, we created the artificial occurrence of accidents via simulation. For instance, given 3 categories  $c_1$ ,  $c_2$ ,  $c_3$  with their respective probabilities  $p_1$ ,  $p_2$ ,  $p_3$ . We randomly generate a number  $r$  between 0 and 1. If  $r < p_1$  then event 1 has occurred, if  $p_1 < r < p_2$ , then event 2 has occurred, and if  $p_2 < r < p_3$  event 3 has occurred. This process is simulated in Matlab and is particularly easy to implement in Simulink. The majority of our findings are based on straightforward calculations of the frequency of events and can be easily replicated with standard Matlab software. In addition, Its worth mentioning that since truck accidents are rare events by their nature compare to other vehicle accidents, we measure the fatality rates approximately follow a Poisson distribution.

The model block diagram contains a random input to each sensor. The input randomly selects an event category according to the estimated probability distribution. Based on the selected event, a random signal is sent to the driver to alert them of the risk of a potential accident. The three sensors are designed to measure specific events such as

atmospheric/road conditions, truck failures and driver behaviours. The three signals are then combined into a single probability of an accident. The combination is a weighted average of the different signals coming from the three sensors. The weights were estimated in Excel using the empirical data. The simulation generates counts that are then used to estimate the accident rates using the new design. A comparison with the original system should reveal an improvement in the performance.

### 3.2 Second Step

This methodology is related to the creation of a business model for our IoT system. We used the Literature Review Methodology mentioned in [46]. The primary reason for choosing this method is to understand the background of current business models in order to create a business model framework for IoT. In the following section we present the three stages used to conduct this systemic review.

#### 3.2.1 Planning Stage

We conducted this systemic review to help us achieve specific objectives. First, we analysed all of the BM definitions presented in the literature in order to understand the concept. We then studied the various BM types and explored the criteria for each type. Finally and most significantly, we looked at the existing IoT BM building blocks. We used two types of data for this section: data gathered from the literature and data generated from our simulation.

Step	Scope
Analysing BM definitions	Using published papers with the BM term as searching criteria
Analysing BM types	Using published papers with the BM and types terms as searching criteria
Analysing BM building blocks	Using published papers with Innovative BM, sustainable business model and IoT terms as the searching criteria

Table 3.3: Methods Protocols

### 3.2.2 Conducting and Reporting Stages

After reviewing all of the BM definitions in the literature, we defined BM as the ways in which businesses generate revenue. An analysis of the literature revealed that the innovative business model is the most common BM type used by businesses and that social and environmental aspects are often ignored. This could be one of the factors related to the failure of business models. We chose to analyse sustainable business models in order to avoid this failure.

#### Business Model Types

A Sustainable Business Model is a type of BM that considers social and financial aspects. [12] defined SBM as a business model that depicts how businesses create, capture and deliver value without consuming the natural, economic, and social capital it relies on. [8] described SBM as a model that illustrates how businesses gain competitive advantages through value delivered to their customers.

Some businesses, such as the fleet and trucking industries, have had a negative impact on our environment as a result of their operation. These industries usually ignore environmental issues to avoid any financial losses they may incur from reducing their operations. Sustainability is becoming an important way for companies to achieve their financial and non-financial goals. We decided to use this type of BM in order to help our clients reduce their negative social and environmental impact while maintaining their productivity and complying with governmental regulations.

In [8], the authors mention some criteria where we can have a SBM:

1. A system where social and environmental aspects are more significant than economic performance;
2. A closed-loop system that cares about the environment and increases environmental awareness;
3. A system with a main goal of delivering the required function exactly;

4. A system that aims to enhance human creativity and experience;
5. system that denies offensive competition and prefers collaboration;
6. A system that encourages the wise use of resources for both individual and commercial use.

Our analysis revealed that many companies have now realised the significance of sustainability for their businesses and that sustainability will not add extra overhead costs. Sustainability means paying attention to the economic, environmental, and social aspects of the business. There is a positive relationship between the economic and environmental business aspects. Businesses that take care of the environment while carrying out their core activities save money while saving the environment [41].

Innovative Business Model (Innovative BM) is defined by [6] as "a process of finding a novel way of doing business which results in the reconfiguring of value creation and value capturing mechanisms." This is one of the simplest and most economic ways that companies can increase their profitability and efficiency. The use of an innovative BM does not mean that we need to be pioneers in terms of creating new products and services, rather, it means being more aware of any changes in the market in order to avoid missing opportunities or being attacked by competitors.

The innovative business model allows companies to innovate, improve their economic growth, and increase their profit margin without any costly investments. Corporate managers and executives can create an Innovative BM in order to weigh all of the possible outcomes of innovations (both product and process innovation) without the need to invest. When correctly constructed, this business model allows companies to recognise even the smallest of changes in the market and make any required changes in their company to adjust.

Innovative BMs can be used in one of two ways: 1) when businesses want to improve their processes and strategies in order to be more competitive, and 2) when businesses want to improve their products and services. Simply, companies build a BM for their products to avoid being attacked by their competitors and ensure the success of their own

product. One CEO mentioned that a good product that is surrounded by a very good business model can stand apart [1].”

Innovative business models are not limited to new products or systems, although it is a great way of managing new technological innovations. An innovative business model can be constructed for modified systems. This type of business model does not require that companies make a significant investment as it focuses more on value creation than value capture. This encourages companies to focus on how they conduct their activities, how they use their resources, and how they communicate with partners and customers. We built a hybrid BM that consists of elements of both the sustainable and innovative business models in order to maximize the strength of our framework and ensure that no aspects are being neglected.

After analysing the available literature, we chose value proposition, value capture and value creation as the main building blocks of our framework.

In the following chapter, we present our IoT system and demonstrate how it outperforms the current safety systems available for trucks. In chapter 5, we provide companies with a business model to convince them to switch to the IoT application. The primary goal of BM creation is to allow businesses to explore all of the opportunities available to them if they take a risk and invest in an IoT system and those they may miss out on if they decide to apply a wait and see strategy.

# Chapter 4

## Simulation and Modeling of The Proposed Approach

### 4.1 Modelling and Simulation

The goal of this study is to determine whether equipping trucks with monitoring sensor devices could improve the efficiency of the transportation system. In order to achieve this goal, the performance of each sensor was modelled as a second order system using MATLAB/Simulink. After running many simulations of the signals generated and sent to the drivers, we proceeded to analysing performance in terms of quality of communication, fuel consumption and accidents reduction. This information can then be used to help build a solid BM for companies. This BM will help them see all of the possible economic, social and environmental benefits of implementing such a system.

#### Simulation Modules

Our simulation model has different modules, each with a specific task. The function of each subsystem is described below.

1. Sensor 1 Assume that we have a new environment sensor with the ability to examine the environment: This module contains an input that generates random numbers

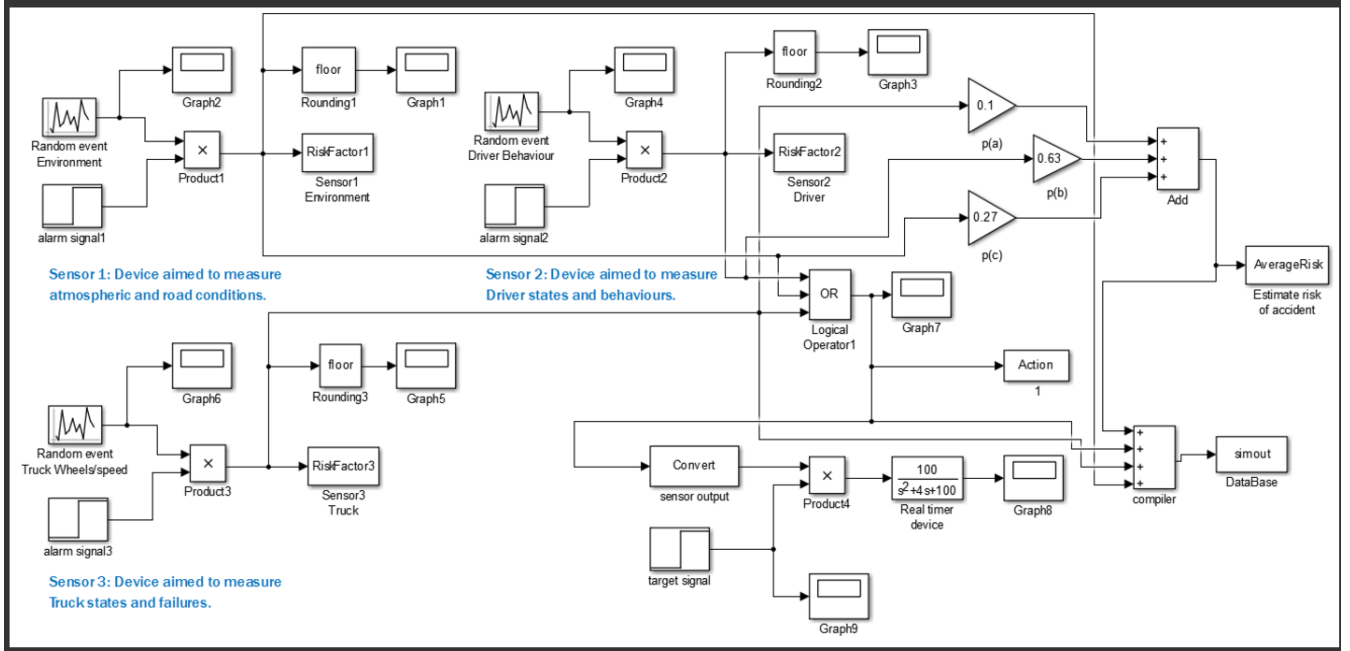
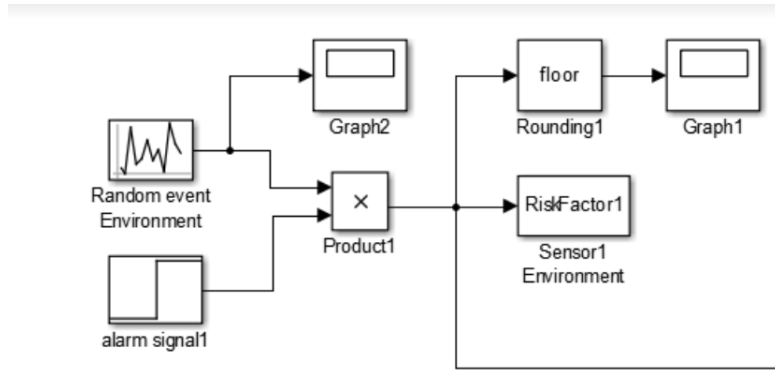

Figure 4.1: Overall System Modelling and Simulation

according to the estimated distribution of the categories of atmospheric and road conditions. The random numbers indicate the type of risk event that has occurred. The probability model was constructed based on frequency calculations (see appendix). Since Matlab generates numbers with decimals and we coded the risk events with integers, we used a "rounding module" to transform the generated numbers into integer values. The information generated from the sensor is sent to a Matlab file named Riskfactor1. Once a random category has been generated, the sensor sends a signal to the driver. Action will be taken if the probability of the risk event is significantly large (we used a threshold of 0.5).

2. Sensors 2 & 3 We propose a new kind of device that has many sensors in it to maximize the ability to measure driver status and behaviour. These sensors involve video camera and voice recognition. In sensor3: we assume that we have a new kind of sensor that can measure truck status and failure): These devices are similar to sensor1. They measure and generate data regarding driver state and behaviours and truck failures



**Sensor 1: Device aimed to measure atmospheric and road conditions.**

Figure 4.2: Sensor1 Logic

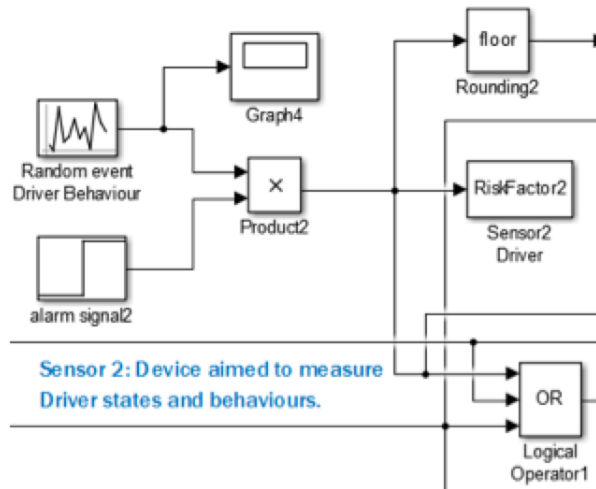

**Sensor 2: Device aimed to measure Driver states and behaviours.**

Figure 4.3: Sensor2 Logic

The random numbers indicate the type of risk event that has occurred. The probability model was constructed based on frequency calculations. The information generated from the sensors is sent to Matlab files named Riskfactor2 and Riskfactor3 for storage.

### 3. Transfer Function

The equation 4 is called a transfer function of any control system. A system is defined as

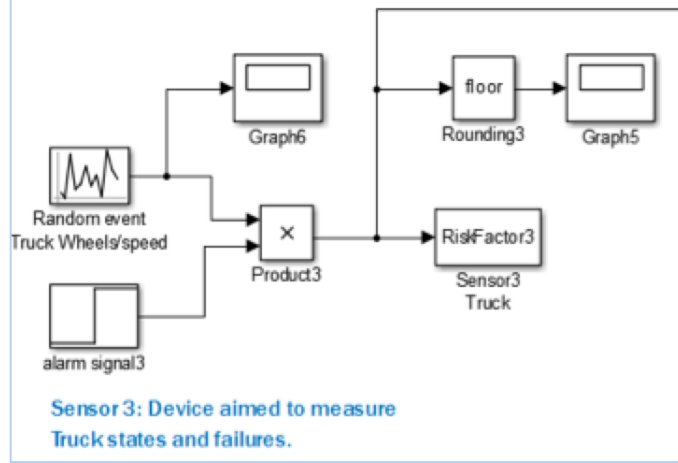

Figure 4.4: Sensor3 Logic

a control system when there are a number of connected objects works together to reach particular result. There are different orders for transfer functions such as the third and forth. As our system is mainly control system we used the second order transfer function in order to get the desired outputs for our proposed sensors. We decide to use this order because of our system's design criteria (fast response time). We also organized our transfer function blocks based on sensors' signals flow [26].

$$G(s) = \frac{\omega^2}{s^2 + \zeta * s + \omega^2} \quad (4.1)$$

A transfer function acts like a black box. It receives an input signal and produces an output. For example, when an accident is detected, the sensor must send a signal to the driver to alert him and reroute him. Unfortunately the signal is not received immediately and sometimes the signal is distorted through the channel of communication due to noise. A good transfer function is robust to noise and fast enough to transmit the input signal with minimum distortion. The unknown values of  $\zeta$ ,  $\omega$  are related to the parameters of the system. These parameters control the behaviour (stability, speed, and settling time) of the system. There are three fundamental parameters:

- The natural frequency  $\omega$

- The damping ratio  $\zeta$
- The settling time  $\tau_s$

The settling time controls the speed of the signal, that is, the time before the signal is stable and received by the driver. The damping ratio is used to ensure the stability of the system. In theory, values of  $\zeta$  are usually in the range of  $[0.1; 0.8]$ . According to the theory of control system, we have the following relationships:

Settling time is defined as:

$$T_s = 4/\zeta * \omega \tag{4.2}$$

Thus, if our goal is to reach a settling time of  $\tau_s=2$  seconds, we should simulate the system in Matlab in order to find the right value of  $\omega$ ,  $\zeta$ . Having done that, we found the values of A and  $\omega^2$  for our model 4. The results indicate a settling time of  $\tau_s= 2$  seconds, which was our initial goal. The values of  $\zeta$  and  $\omega^2$ , based on the requirements of the settling time are:  $\zeta =4$ ,  $\omega^2 =100$ . Since the system is stable with a short settling time, we believe that the second order system is appropriate for sensor modelling. A graph of the system 4.6 response is provided below

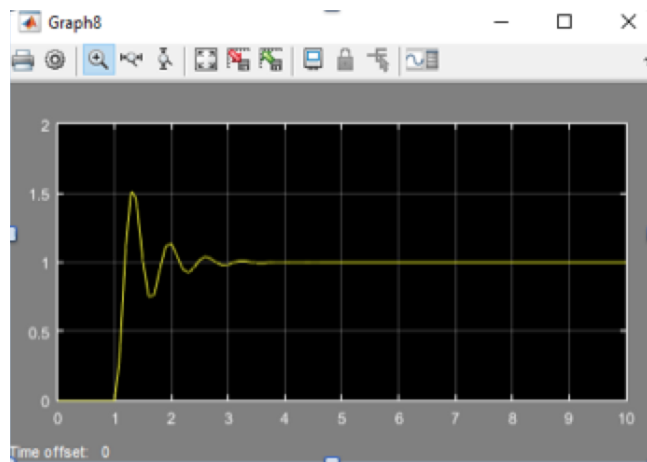

Figure 4.5: System Response Time

We observed that the settling time was about 2 seconds, which is fast enough to alert the driver and allow him to take the appropriate action before any accident can occur.

The plot also reveals a stable system after a 2 second transient period. Calculation of parameters: A, B Setting the value of  $s=2$  seconds, with a damping ratio of  $=0.2$ . The equation  $\tau s=4/\zeta*\omega$  implies  $2=4/(0.2*\omega)$ , thus solving the equation, we obtain:  $\omega=10$ . Using these values, we find that  $2*\zeta*\omega=4$ , and the value of  $b$  is  $b=\omega*\omega=100$ . This can be improved by increase the order of the system. For example, using a third order system, the transfer function would be:

$$G(s) = \frac{a}{s^3 + a * s^2 + b * s + c} \quad (4.3)$$

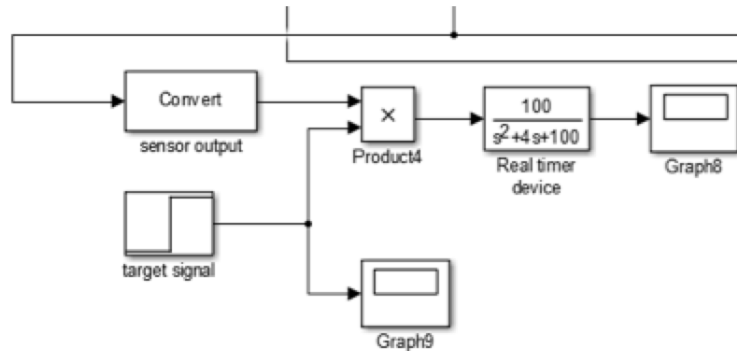

Figure 4.6: System Response

**A Central Database** For advanced analysis purposes (data collected using external servers such as hospitals and governments), we added a central database modelled using a Mat-lab file (Simout). All of the sensor output is collected in a single file that is easily accessed by the various systems in a communication network. From a Matlab point of view, the database is a multidimensional matrix, where rows indicate dates, columns indicate the type of event, and the matrix coefficient is the frequency of occurrence or number of times the event has occurred during that particular day.

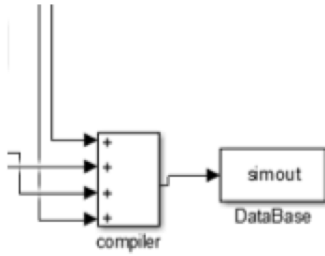

Figure 4.7: Central Database

### 4.1.1 General Model Description

#### Sensor 1

Devices that are able to measure the atmosphere and Road condition. We make an assumption that this sensor has many sensors inside with ability to detect both weather and road condition or more generally the environment. the simulation of this sensor consists of the following components:

1. Random Event Environment: This was chosen instead of the Uniform Random Number environment since each event has different occurrence frequency.
2. Alarm Signal: A step function used in order to better detect the signal from the sensor.
3. Graph 2: Used to represent the current sensor status.
4. Product 1: Multiplies the output of the random event by the step function to provide better signal detection.
5. Risk Factor 1 (Sensor 1 environment): Represents the sensor's output. Matlab gives a decimal number and a "rounding module" was used to transform the generated numbers into integer values.
6. Graph 1: Shows the output of the sensors in graphical form.

The rate of event occurrence entered in the sensors were obtained from historical data. The probabilities of detecting an event related to weather and road conditions were calculated as the incidence of a single event divided by the total frequency of all events.

The random events were divided into two categories: 1) accidents due to weather conditions in a specific period of time (rainy, cloudy, snowy, clear), and 2) accidents due to road conditions in a specified period of time (road surface is wet or slippery).

## **Sensor 2**

Devices that are able to measure driver states and behaviours. We made an assumption that this sensor has many sensors inside with the ability to detect driver states or performance and driver behaviour. The simulation of this sensor consists of the following components:

1. Random Event Driver Behaviour: The frequency of accidents caused by truck driver behaviour entered into this sensor was obtained from the historical data.
2. Alarm signal: A step function used in order to better detect the signal from the sensor.
3. Graph 4: Shows the input of the sensors in graphical form.
4. Product 4: Multiplies the output of the random event by the step function to provide better signal detection.
5. Risk Factor 2: Represents the sensor's output. Matlab gives a decimal number and a "rounding module" was used to transform the generated numbers into integer values.
6. Graph 3: Shows the output of the sensors in graphical form.

This block aims to detect risky events caused by driver states and performance. When the sensor detects a risky event, the result is compared to the probability that this event will cause an accident using probabilities calculated from the historical data. The historical data we used in our simulation showed that acceleration in traffic lane, sleepy driver, making a U turn, fatigued driver, driver over speed, gender, overall driver health could lead to accidents.

### Sensor 3

Devices that are able to measure truck states and failures. We made an assumption that this sensor has many sensors inside with the ability to detect truck states and failures. For example, a sensor that has the ability to check the steering default or tire status. The simulation of this sensor consists of the following components:

1. Random Event Truck Wheels and Speed: The frequency of accidents caused by truck failures entered into this sensor was obtained from the historical data.
2. Alarm signal: A step function used in order to better detect the signal from the sensor.
3. Graph 6: Shows the input of the sensors in graphical form.
4. Product 3: Multiplies the output of the random event by the step function to provide better signal detection.
5. Risk Factor 3: Represents the sensor's output. Matlab gives a decimal number and a "rounding module" was used to transform the generated numbers into integer values.
6. Graph 5: Shows the output of the sensors in graphical form.

Once a risky event is detected, action is required in order to prevent accidents and enhance safety. We proposed a system that can determine the probability that a risky event will cause an accident and send an alarm if the probability is high. We calculated the probabilities for each cause (driver, environment, and truck) and divided the probability by the total number of accidents. This was defined as the estimated risk of accidents or the average risk. The results indicated that the probability of an accident caused by driver behaviours is higher than the probability of an accident caused by environmental and mechanical factors.

## 4.2 Simulation Robustness

Considering the potential costs incurred as a result of a false alarm, it is ideal for the system to be robust enough to allow for a margin of error. Once the average risk was calculated, we designed a block that can increase the robustness of our simulation. The OR logic component was added with two logical values (1 or 0). The value 1 sends an alarm signal if the risk level is high enough. We choose the threshold value of 0.5 (the average probability exceeds 0.5). This means that a risk event is likely to occur and the driver must be alerted to take the appropriate action. The value 0 either ignores the risk event (since the probability of the event is not high enough) or sends a notification to the driver. The simulation of this block consists of the following components:

1. Logical Operator 1: Logic values of 0 or 1. Makes the decision whether or not to send an alarm to the driver based on real time data.
2. Sensor Output: This block is responsible for changing the average risk to 0 and 1 values.
3. Target signal: Based on a predefined threshold (the required overshoot, response time, and settling time).
4. Product 4: Converts the average risk factor into an alarm/notification. The risk factor result is multiplied by a real-time transfer function based on a predefined threshold to provide the desired settling time and transfer function.

$$G_{(s)} = \frac{100}{s^2 + 4 * s + 100}$$

If the result is 1 or close to one, an alarm will be sent. If it is 0 or close to 0, we either send a notification or no action is taken.

## 4.3 Simulation Results

- Reduction of Fatality Rates The benefits of using sensors include the reduction of signal transmission time, congestion rates, server maintenance costs, and potential environmental impacts. We now look closely at the fatality rate using IOT sensors. The number of traffic fatalities is stochastic and assumed to follow a probability distribution. Historical analysis of periodic fatalities indicates:

1. <2deaths (or injuries)/month p=0.3
2. [2; 8] deaths (or injuries)/month p=0.6
3. >8 deaths (or injuries)/month p=0.1

This indicates that, 10 percent of the time, the number of deaths or injuries is above 8 in a given month, and between 2 and 8 60 percent of the time. If these figures continue to apply, we expect these probabilities to decrease when system sales increase. Although we cannot predict the exact probability distribution for fatalities when truck drivers are monitored using IoT sensors, a few assumptions allow us to estimate the number of fatalities during a certain period of time. Since accident rates are reduced when using sensors, the chance index with IoT can be modelled using a Poisson distribution. The formula is obtained using Poisson Distribution:

$$P(x) = \frac{e^{-\lambda} \lambda^x}{x!} \quad (4.4)$$

The average number of fatalities without the sensor system can be estimated (on average) using the empirical data, as follows:

$$u = 0.3 * 1 + 0.6 * 5 + 0.1 * 10 = 4.3 \quad (4.5)$$

. The probability that sensor 1, sensor 2 and sensor 3 will detect a risk event is 0.3, 0.6 and 0.1 (respectively). The Matlab simulation results revealed that the average number of events related to atmospheric conditions, driver behaviour and truck failure were 1, 5 and 10. If the IoT sensors reduce this average by only 1 percent, the probability distribution of the number of deaths in congestions using the Poisson formula 4.4 will become:

1.  $<2$  deaths (or injuries)/month  $p=0.20$
2.  $[2; 8[$  deaths (or injuries)/month  $p=0.77$
3.  $>8$  deaths (or injuries)/month  $p=0.03$

More than 8 fatalities will occur only 3 percent of the time. This constitutes a significant drop compared to the initial 10 percent probability. It still remains to be seen if the Poisson distribution assumption holds, but we believe that this assumption is reasonable since the Poisson model is well suited for rare events, which is the case when IOT is used to monitor drivers. We therefore expect that the IoT sensor system will enhance both the economic value and the prestige of companies, attracting more customers. Moreover, because of the decrease in accidents, the social cost will be lowered.

- **Fuel Consumption** Various factors affect fuel consumption. Increases in fuel consumption mean larger negative effects on the environment (releasing more  $\text{CO}_2$  etc.). It is therefore important to measure the impact of the new design on fuel consumption. Fuel consumption becomes a concern when the truck is consuming more fuel than it is supposed to. This can be due to a faulty engine, poor engine oil, poor fuel quality, poor maintenance (at the source), bad air conditioning, using the wrong gears, and a bad driving style. If the driver is driving aggressively and does not quickly shift gears to the lightest one, the engine turns faster, consuming more fuel. Stopping suddenly while driving also has a negative effect on fuel consumption. The sensors will monitor driving behaviour along with engine oil, gears and fuel quality. Once any of these factors reaches a critical value, an alert signal will be sent to the driver to stop the vehicle, modify his behaviour, or proceed differently.

# Chapter 5

## Business Model for Our System

In this chapter, we will be using all of the data generated from our analysis of the literature and our simulation to build a unique and hybrid BM that will help us to contribute to the body of knowledge regarding BMs for IoT. The primary goal of this BM is to show businesses how to maximize their profit margin by implementing IoT solutions in different contexts or different industries. This sustainable innovation business model will also ensure that the social and environmental aspects of fleet companies are addressed.

### 5.1 Business Model Framework

Technology success is related to many factors not only the power of the technology itself. If we want IoT, for example, to succeed compared to other technologies such as M2M, we need to bring it successfully to market and convince businesses to implement it. The key aspect of IoT is not about the technology alone but on how to utilize this technology to make a situation better. Business models are used to perform this function, to show businesses what is the return from their investment in this technology.

## 5.1.1 Business Model Framework for the Internet of Things Driver Monitoring System

This chapter presents the business model for our IoT system developed in accordance with the methodology presented in [2.6](#).

### Value Proposition for Our System

The primary purpose of a value proposition is to express why consumers should buy or use the developed product or service instead of others. In order to convince them, we must emphasise the delivery of superior performance and how end users needs are being met. First, we need to identify the key partners (ecosystem) responsible for delivering values to our customers. Next, we need to identify our customers and their needs. Lastly, we need to deliver our offer and identify how it can help in the solve common problems

- **Identifying Key Partners**

The open ecosystem of IoT is a key feature of this technology. The involvement of multiple partners in this ecosystem has many implications for both businesses and their customers. Some of the advantages of the IoT ecosystem for companies include the creation of new markets resulting from the involvement of multiple industries, participation in the current market expansion, and access to the business models of different industries [\[77\]](#). The IoT ecosystem enables consumers to get product/service from specialized companies without the need to deal with all of them.

1. Device manufacturers (e.g. sensors, actuators, etc.)
2. Cloud computing company (e.g. Azure) and wireless communication
3. Software developers (e.g. application)

- **Identifying our Customers**

We have two types of customers:

1. Main customers, which include fleet and truck industries.
2. Potential customers, which include hospitals, governments, research institutions, gas tax agencies, competitors, etc.

Customers are a crucial factor in the success or failure of any business and business model. A good balance between the value offered and the value received is necessary in order to create a valid equation between our solution and our customers. In order to do so, the needs of the customers must be clearly stated in order to ensure that they are met. Here is a list of fleet company needs and requirements: improve operational efficiency by improving safety and security, ensuring productivity, reducing operational costs, reducing travel time, lowering fuel consumption, reducing greenhouse gas emissions (GHG), and improving sustainability.

- **Illustrating our Promises**

Advancements in IoT technology will facilitate the fulfillment of the needs of both fleet and truck companies. IoT architecture consists of several layers that perform specific functions in the most intelligent manner. IoT architecture also works in a way that makes it difficult for customers to distinguish between products and services, unlike previous technologies in which there were significant differences between the two and customers had to pay in order to receive services.

The sensor layer plays a key role in the IoT platform. In our solution, we proposed three types of devices, each with multiple sensors. The use of sensors in IoT solutions provides two distinct advantages. First, the price of sensors is constantly dropping. The available data reveals that the average price for a wireless sensor with a range of approximately 250-300ft and a battery life of 5+ years is between 40 and 60 US dollars. Future projections based on Moores law, which states that the power of computer-based systems doubles every two years at the same cost, indicate that the cost should go down to half its current level

by 2020. Thus, solution developers can add as many sensors as they need at an affordable price.

Second, sensors have a high accuracy rate in detecting any abnormalities due to their relatively high sensitivity and fast response time. Our model suggested that a detected event will generate a signal within  $\tau_s = 2$  seconds [4](#). Of course, a highly sensitive system is more likely to generate extra costs due to false alarms. In order to minimize the false alarm rate, a robust component was added to allow a reaction only if the probability of a risky event reaches a particular threshold. We proposed the use of many sensors in each device to detect events related to the environment, vehicle and driver and most importantly, to gather real time data delivered through the system to interested parties.

The environment device includes temperature and humidity sensors, CO<sub>2</sub> gas sensors, a weather application, a video camera, a GPS, and light sensors. The vehicle device includes smoke sensors, speed sensors, fuel level sensors, and steering vibration sensors. The driver device includes a video camera and voice recognition software. The sensors in one device may detect an event that helps in another area. For instance, fuel level and CO<sub>2</sub> gas sensors in the vehicle device are used to determine the impact on the environment by determining the amount of fuel burned and the amount of gas produced.

The sensors are not only designed to detect risk events, they are also designed to collect data. This real-time data is a key asset for any business as it can help them attain their goals by monitoring their current operations. The data in our system can take two paths, either to notify vehicle operators or to be stored in the cloud. The cloud has many business applications, with large-scale and high speed analytic capabilities over a vast volume of data to generate immediate reports for managers to give them quick insights about their business. The central database is also another promise provided by our solution, allowing businesses to store different types of data and sell that data for extra benefits.

In order to improve operational efficiency, we propose a new sensor type with the ability to detect any risky driver behaviour, any vehicle defect that can lead to an accident, and any environmental conditions that can make the drivers job harder, such as heavy snow. Sensors are capable of detecting events within a few seconds, with a high accuracy rate and

fast response time. The system then sends an alarm or notification to the truck operator in order to adjust their behaviour and take any necessary action . The data generated is then sent to the cloud via LTE communication.

## **Value Creation and Delivery**

Value creation is a key challenge when building a business model in the context of IoT due to the complexity of the IoT ecosystem and the variety of stakeholders. When customers choose an IoT solution, their main requirement is a solution with the ability to improve their current situation. While most businesses care more about the return on investment (ROI), the value created can be significantly different from one stakeholder to another. The value created also differs for businesses and their customers. Our BM must therefore account for these differences. Satisfying all of these needs and requirements is not difficult using this type of multi-purpose application, despite problems such as the immaturity of the technology and a lack of a well-structured BM.

In our BM, value creation is needed to convince businesses to switch to IoT-based solutions, which may open many opportunities streams such as gaining a competitive. The strategic resources of a project must be included as a crucial part of value creation. In our IoT system, the sensors, vehicles, and drivers are considered core resources. Here is the potential value creation in our system and the detail monetary benefits will be mentioned in Cost-Benefit Analysis [5.2.3](#):

- Value from safety and security: sensors are used to detect any risky events related to driver performance, environmental conditions or vehicles. This will help reduce the rate of accidents, lower insurance rates, lower repair costs, avoid losing work hours, and improve quality of life.
- Value from real-time data collection: sensors are used to collect real-time data that can be used by all interested parties (such as governments).
- Value from reduced energy consumption: sensors are used to calculate and estimate their fuel usage, which will help reduce their operational costs.

- Value from sustainability: sensors are used to minimize Greenhouse emissions that result from fuel consumption (environmental impacts) and to improve safety and minimize accident rates (social impacts).

The simulation result was surprisingly clear: assuming the distribution of accidents follows a Poisson distribution, the majority of trucks involved in accidents related to driver behaviour or environmental conditions was reduced by about 7 percent. This value was an average of 10 percent without the IoT solution to approximately 3 percent after introducing the IoT.

The analysis also revealed the most active drivers avoid risky events, increasing their safety and security and their survival rate when involved in accidents. For instance, when more than 10 accidents per year are simulated it give a result that the median survival rate is nearly 4 times more with our solution compared to only 1.3 per year without our system. The key to unlocking these safety and security benefits for transportation and logistics companies is to develop more IoT sensor based systems, in order to avoid the shortcomings often experienced.

An emphasis on safety can have significant economic and social impacts. The reduction or avoidance of accidents to save lives and company costs is one of the key points that strengthens our application. Sensors work to detect risky events such as driving over the speed limit or changing lanes without signalling. Risk detection is based on the stream of data generated by different types of sensors. If the average risk is high, a notification will be sent immediately to the driver via the "SafeDrive" application. If the possibility of occurrence is low, there will be no action taken by the system. These warnings prevent accidents or minimize their severity.

Our proposed IoT system is designed to reduce the accident rates in the fleet and truck industries in order to directly and indirectly benefit businesses. The sensors were selected based on the causes of accidents we investigated in chapter 2. Driver behaviours (such as drinking alcohol), driver performance (such as fatigue) and driver health and wellness are the top causes of collisions. A video camera, heart rate monitor, eye tracker, and speed and voice recognition sensors were used in our system to reduce the percentage of

accidents caused by these factors. This will help fleet companies save on fleet insurance, health insurance, repairs and rentals, and working hours.

The second benefit of improving safety and security is improvement in the Quality of Life. The use of an IoT solution in a fleet will help avoid accidents, reducing injuries and the rate of casualties, which will enhance quality of life (QoL). This is one way that IoT can help businesses contribute to the improvement of society. The World Health Organization (WHO) defines QoL as the individuals perception of their position in life, in the context of the culture and value system in which they live and in relation to their goals, expectations, standards and concerns [80].”

QoL is an important concept in occupational accidents, especially for fleet drivers who have higher chances of being involved in an accident than other workers. Although traffic accidents vary in type and severity, the majority result in death or injury. Increasing fleet safety and security using an IoT based application will improve QoL by minimizing accidents, fatality rates, and medical expenses and procedures.

Moreover, the data generated by the sensors will be sent to the cloud via LTE communication, allowing for fast response times. There are many applications that can be used in the cloud to analyse data and generate reports in a short time. This helps fleet managers evaluate the overall fleet performance and evaluate and score their drivers based on their performance. This creates more of a safety culture and increases overall fleet productivity.

**Value from real-time data:** Sensors are used to collect real-time data that can be used by all interested parties (such as governments). The system has a central database that collects all of the information and makes it available in real-time due to the fast response time of the IoT sensors. It is expected that future sensors will be more economical and efficient, adding more value to the time information. Using a second order system, our calculation showed a 2 second response time. The use of more complex models such as 3rd or 4th order representations in the design of sensors will lead to faster response times, cutting them by more than 50 percent. It should be noted that the current 2 second response time could not be reduced any further due to the trade-off between response time and overshooting (System Stability).

Real-time data is the key asset provided by sensors to the customer. Drivers are difficult to manage and control due to their remote working locations. This system solves this problem by generating real-time data for fleet managers regarding the performance of their drivers and how their vehicles have been used. In our solution, environmental conditions (such as weather), vehicle status (such as engine temperature), and driver behaviour are measured using sensors installed in the vehicle. This can help managers look at the situation from all angles.

**Sensors as a Service:** This is a type of business model has been extensively used in the context of IoT data. Companies can benefit from the data collected by sensors in a variety of ways. In our system, we propose that fleet companies can sell their data to many institutions, obtaining financial returns. The data is stored and filtered in a central database. Governments (e.g. The Ministry of Transportation) can purchase data from fleet companies in order to look at road performance. Data about fuel consumption, idling, miles travelled, and safety and accidents can be used to update laws and regulations in order to manage risk. Purchasing data would be easier than visiting each company and interviewing them.

Institutions such as hospitals may also be interested in this data. Fleet companies may sell them data about accidents and their severity, deaths, and injuries. This can help hospitals improve their primary health care programs and estimate the main causes of accidents. Insurance companies may wish to purchase this data to help them provide the best insurance rate estimates based on actual vehicle usage. Educational institutions may wish to purchase this data for research purposes since a lack of data is a major challenge for graduate students.

Highly restricted data can be sold by fleet companies to their competitors. Some companies only hire professional drivers in their fleet in order to ensure efficiency. A dataset published by the American Transportation Research Institute (ATRI) revealed that 88 percent of accidents are caused by drivers who were previously involved in accidents [48]. This information would therefore be useful to businesses when hiring drivers.

**Value from Reduction in Energy Consumption and Sustainability:** We did

not use smart fuel alternative vehicles in our system since not all companies want to make such a huge investment. In addition, the use of fuel or electricity to charge vehicles also consumes energy. In order to make societal and environmental contributions, we proposed fuel level, speed, CO<sub>2</sub> and temperature sensors to help managers estimate the unnecessary amount of fuel consumed by trucks.

*Fuel level sensors and speed sensors* are used in our solution to calculate and estimate fuel usage, helping reduce operational costs. Many factors such as speed and engine defects increase energy consumption. Monitoring these variables keeps the energy consumption at a certain threshold, sending an alert signal when fuel consumption breaches that level, and saving companys money.

CO<sub>2</sub> and temperature sensors are also used to minimize greenhouse emissions resulting from fuel consumption and negatively impacting our environment and society. Growth and return on investments are fundamental ingredients of value creation. The goal of a good management strategy is to increase one or both by identifying sources of competitive advantage that place the company ahead of trends and drive superior performance.

The geographic and environmental components of transportation and logistics companies are fundamental to performance and cash flow. Because of international regulations on CO<sub>2</sub> emissions, such as tighter emissions standards, most companies in the industry have to invest significant amounts just to stay in business. Since older vehicles tend to have higher CO<sub>2</sub> emissions, the annual investment required to renew a fleet and other assets to operate the network could be significant and exceed cash flow. By controlling fuel consumption and driver behaviour, the system prolongs the lifetime of the vehicles and reduces their negative impact on the environment.

## **Value Capturing**

Many research papers indicate that value creation and value capture are the key principles of any business model. Together, they represent the business logic of a company. These principles allow businesses to maintain their position in their markets and measure the

results of their efforts. If either of these components are insufficient, the entire business model can collapse.

Companies often make efforts to satisfy customer needs using innovative products and services with financial goals such as improving their profit margins and sustaining their revenue growth. Financial returns from an investment is a critical concern for companies because of the uncertainties involved. BMs are designed to ease this concern by allowing managers to consider the costs and benefits of new products or services and decide on the optimal trade-off.

Insufficiency in constructing rational value creation may lead to misjudgement regarding the perceived benefits for the customers and revenue received by businesses. Poor value capture (a company's revenue logic) may lead to the failure of the entire business model since it cannot capture the value added and turn it into profit. The authors of [51] use the failure of the Skype business model as an example of substandard value creation dialectics in which customers receive more than the company. Skype struggles to turn their services into profits as it offers free voice/ video calls over the Internet. The majority of their clients prefer using the free service instead of paying for a premium account with little added benefits.

It is therefore critical that the value creation and value capture of our business are reasonable and related. Studies have shown that there are two effective methods to consistently add and create value, either by following the lowest price strategy or by providing superior value to customers [74]. There are many models that can be used to represent value capture (revenue and cost models); however, value networks in Internet-based and technology-based products/services can be very different than other types. The primary differences are the number of stakeholders involved and the pricing of services in IoT based applications.

Since our solution is IoT-based, the boundaries between products and services are blurred. This may affect revenue and cost. We will be focusing our value capture on services since they are considered more stable sources of revenue compared to products, even though many consumers require more products than services. There are multiple reasons why it

is important to incorporate services in any proposed solution if businesses want to gain a competitive advantage [57]. First, services are less visible than products, making it difficult to imitate services offered by competitors. Second, companies can increase their product sales when their services are performed by these products. For instance, in our IoT based solution, we are using sensors to provide services for fleet companies, which will increase the volume of the sensors that are sold.

## 5.2 IoT Based System as a Cost-Effectiveness Solution

### 5.2.1 Costs

Involve the following costs;

1. Hardware costs (Sensor costs): The dramatic decrease in sensor prices allows for their extensive use in order to achieve the overall objective. As previously mentioned, we propose a solution with three new device types, each containing multiple sensors. This helps with the optimization of our solution and reduces the amount of sensors that need to be purchased. Infrastructure costs (Middleware, network and cloud):
2. Middle-ware: Since objects are not usually designed to communicate with each other in IoT, we need to add gadgets to enable them to do so.

### 5.2.2 Revenue

Revenue structure simply de

nes how businesses obtain money from the provided solution. The ways companies generate revenue from IoT based solutions is still not clear due to the diversity of stakeholders and the complexity of the ecosystem. There are some revenue models available and can be used in a single BM. Further, a large portion of our solution involves using sensors as a

means of performing services (Sensors as Services) for fleet companies which enable us to get some profit from selling data gathered by these sensors.

Two different types of business model revenues have been mentioned in the literature: direct and indirect. There are four subtypes of direct revenue: The freemium revenue model (Microsoft Azure), pay as you go (used by Amazon AWS), up selling to increase the capacity for instance, and cross-selling to add new features. The indirect revenue model is more ambiguous. It has only been used by Amazon and involves trading between two markets. It is worth mentioning that, the benefit that our system provide to the fleet businesses are not all monetary. However, it can lead to financial benefits in the long term.

### **5.2.3 Cost-Benefit Analysis**

This section provides a cost-benefit analysis to systematically calculate and compare the benefits and costs of the IoT based system. The analysis should provide the rational behind the expectation of potential economic gain and market competitiveness. The system is viable and thus constitutes a sound investment if the benefits outweigh the total costs.

- Purpose of Analysis: Addressing the uncertainty of financial return for fleet companies with respect to the IoT based system by examining service costs and benefits in order to decide on the optimum trade-off.
- Overview of the System Under Investigation:
  1. Target customer: Fleet companies (such as Walmart, Sysco and other companies of the same relative size)
  2. Decision question: Should fleet companies choose the IoT based system? Do the benefits outweigh the costs?
  3. Description: Monitor drivers and vehicles for risk events and send alerts if necessary.
- Assumption Underlying the Analysis Assume benefits and costs are observed 5 years from now:

1. Time window:  $T=5$  years operations
2. Interest rate (annual):  $i = 2$  percent = 0.02
3. Data volume (annual):  $V= 1000$  Billion messages
4. Number of trucks  $N=100$  trucks
5. Average price of a sensor  $P=1$  Dollar/sensor
6. Cloud price: 1 Dollar /Billion messages (Amazon Web Services)
7. Connectivity: 0.08 Dollar/277 days (Amazon Web Services)
8. Lifetime of each sensor:  $L >5$  years
9. Improvement of  $r=7$  percent
10. Average Price of a data set = 2000 Dollar
11. All values are in US dollars

We choose to use the NPV to calculate the difference between cash inflow and cash outflow of a particular project. It is a forecast tool used by businesses to help them estimate the return from their investment [10]. The present value of an investment is computed based on the real interest rate. Using the average interest rate of the past 12 months (5.5 percent) with an inflation rate varying from 2 to 4 percent (or about 3.5 percent on average), the real cost of capital is 5.5 percent (3.5 percent or 2 percent). This means, for every dollar invested in the risk free asset (such as a bank account or US Treasury bill), the company can expect a revenue of 0.02 US dollars. Conversely, the cost of borrowing one dollar is 0.02 US dollars, which can make a big difference for such large companies.

There are many companies provide cloud services such as Microsoft Azura, Amazon Web Services (AWS), Google Cloud Computing and IBM Cloud. We decide to use the AWS due to detailed pricing data that is available in their web site. Furthermore, the average price of selling sensor data has been used based on a study published by Harvard Business School [47]. The rest of the data used in this Cost-Benefit Analysis is generated from our simulation.

	<b>Cost Analysis</b>	<b>Benefit Analysis</b>
	TPV (purchasing sensor cost) = 1086.877\$	TPV (Data/information sales) = 1086876.972 \$
	TPV(messaging/cloud cost) = 905.73\$	TPV(Saving in Accidents prevention) = 190.2034701\$
	TPV (connectivity cost) = 0.477\$	TPV(Saving in fuel consumption) = 682.196446\$
	TPV (maintenance cost) = 0\$	TPV (Saving in Driver idling time) = 238629.2735\$
	TPV (operating cost) =679298.1074\$	
<b>Total</b>	=681291.1914\$	=1326378.643\$
	<b>Total Profit= 645087.4516\$</b>	

Table 5.1: Cost-Benefit Analysis

Finally, it should be mentioning that the benefits of the system affect the company, their customers and the stakeholders. The revenues are also direct or indirect, quantitative or qualitative. The quantitative benefits rely on a few assumptions and past data regarding fuel consumption, average speed and distance travelled by trucks, and the probability distribution of the fatality rates in accidents involving trucks. The qualitative benefits, although difficult to quantify, are fundamentally important in the decision making process. Customer satisfaction that results from improved service is difficult to estimate, yet customer satisfaction is the sole reason for the firms existence. The social cost of accident related injury and fatalities amounts to millions of dollars per year, yet the pain and suffering experienced by family members is hard to quantify. This section will cover the reduction in fuel consumption and public health costs due to the reduction of accident rates, proving that these benefits alone significantly exceed the investment costs incurred by companies.

Other Benefits: Customer willingness to pay for company services is expected to increase as service quality improves, resulting in substantial revenues for companies. With a stable market share due to satisfied clients, the company can sustain a significant revenue growth over a relatively long period of time, reducing the uncertainty regarding future financial returns.

## IoT Potential Risks

IoT based systems are staggeringly transformational, but they can also be highly disruptive to businesses since they significantly increase the number of security risks businesses and consumers will inevitably face by connecting to the cloud. Devices that connect to the Internet through an operating system are at risk of being compromised. To mitigate the risk, our system must be designed with security in mind and incorporate security controls, leveraging a pre-built role-based security model. Because these devices will have hardware, platforms and software that companies may never have seen before, the types of vulnerabilities may be unlike anything these companies have ever dealt with. It is thus critical not to underestimate the elevated risk.

Redundancy is a critical security feature of the design; if one sensor fails, another sensor is there to take over. For example, in the health care industry, medical devices are available to monitor patient health statuses and dispense medicine based on the analysis performed by these devices. The consequences could be tragic if these devices were to become compromised. The main challenge for enterprises and their customers lies in identifying where security controls are most needed and then implementing effective controls.

Organizations will need to conduct risk assessments, often relying on third-party expertise, in order to identify what the risks are and how best to contain them. The cost of containing those risks can be reduced to redundancy costs and effective control risk management research. Redundancy costs are expected to decrease exponentially in the near future as the technology becomes more and more available and sensor prices drop significantly. As for control risk management research, the cost is distributed over a large number of companies and private institutions such as universities.

The development of a novel business model is necessary for any business to operate efficiently and effectively. Regardless of the type of BM, a number of variables need to be taken into in consideration. One of these variables is customer needs. Success or failure in addressing these needs is directly related to the success or failure of the entire project. The Internet of Things (IoT) generates new business opportunities by connecting physical objects with a multitude of sensors. IoT research focused on technology and business

models is an area which has been relatively unexplored.

# Chapter 6

## Conclusions and Future Work

Commercial vehicles, which are designed for freight transportation, have played an important role in the growth of economies. Managing these vehicles is a difficult job due to a variety of tasks such as scheduling, routing, maintenance, and insurance. Various technologies have been proposed to facilitate the work of fleet managers. There is no doubt that the application of technologies can help commercial fleet companies operate more efficiently, increasing benefits for both the business and their customers.

Our analysis identified the potential economic gains of implementing an IoT-based system. The results of our prediction support our general hypothesis that IoT technology improves the current situation of fleet companies. We did not find any variables that predicted significant failure in the new system, undermining its economic viability. Of course, the analysis was restricted to available commercial vehicle data, more specifically, driver behaviour and attitudes.

Changes in the economic dynamics of the nation along with new legislations could certainly affect the performance pattern of the proposed system. Our prediction pattern is that the affordability of sensors in a high-tech society will promote the continuation of the use of IoT technologies and neutralize the potential risks of poor economic outcomes. Our model presents a significant contribution to the theory and application of IoT systems in fleet management by identifying drivers who require further observation, avoiding risky, damaging and costly events. The cost-benefit analysis of the IoT investment asserts its

viability, and the environmental impact of this technology is significant. The social impact of our system, reducing accidents and saving lives, is also significant.

Despite the benefits mentioned above, we cannot rule out the possibility of bias. Our analyses had several limitations that may be important for future research that builds upon our findings. First, the current results are based on presuppositions and may not generalize to other economic environments. For example, we insisted that the probability distribution of accidents followed a Poisson distribution with a constant rate based on past data. Second, the simulation uses a second order dynamic model. To improve our understanding of IOT performance in more realistic conditions, future research should test these hypotheses against alternative hypotheses about different probability distributions such as a normal distribution or uniform distribution and examine various system orders such as a third or fourth order.

In the simulation portion, we used the MATLAB environment as a hypothesis-generating model and therefore, the issue of design error does not apply in the conventional sense. MATLAB provides built-in functions and bloc diagrams in the Simulink environment to build models, allowing the duplicability of the model, which is essential to rule out flaws in the results. Future work should try higher-level simulation environments.

Our work has summarized the benefits of IoT and identified limitations in the hypotheses underlying the model. We offer these findings to stimulate efforts to test hypotheses regarding when to monitor drivers using IOT sensors in order to minimize risk events and maximize benefits, and to personalize preventive care for drivers and the fleet vehicle, reducing the burden of potential costs (accidents, injury, death, pollution).

Furthermore, the IoT system could be used more efficiently in conjunction with a GPS based system. GPS tracking solutions are a necessary tool to manage a mobile workforce and have been widely adopted by fleets in the service industries. GPS tracking technology has changed the way fleets operate and made businesses more efficient. Despite the widely acknowledged benefits from businesses that already use GPS tracking, it seems that the main advantage of using this technology is being able to track the location of vehicles. Coupling the GPS technology with the IoT system can generate substantial benefits for

service fleets. More research is needed to determine the extent to which the two systems can cooperate efficiently.

We proposed an IoT-based system that can be used by fleet companies and constructed a business model to examine our hypothesis that the benefits of this system will outweigh the costs. The system simulation and qualitative analysis of the business model indicated that this system can be a valuable and affordable solution for businesses.

For future work, students may make our simulation more complex by trying third or fourth-order transfer functions instead of the second-order transfer function that we have used in this thesis. They may also validate our proposed system in reality by using different types of sensors. More sensors can be added to this work in order to make it more beneficial. In terms of BMs, students may also examine different types of BM components.

# References

- [1] R Amit and C Zott. Business Model Innovation: Creating Value In Times Of Change. *Universia Business Review*, pages 108–121, 2009.
- [2] Raphael Amit and Christoph Zott. Creating Value Through Business Model Innovation. *MIT Sloan Management Review*, (53310):41–49, 2012.
- [3] Kemal Ayyildiz, Federico Cavallaro, Silvio Nocera, and Ralf Willenbrock. Reducing fuel consumption and carbon emissions through eco-drive training. *Transportation Research Part F: Psychology and Behaviour*, 46:96–110, 2017.
- [4] Maryam Bagheri and Siavosh H. Movahed. The Effect of the Internet of Things ( IoT ) on Education Business Model. *12th International Conference on Signal-Image Technology & Internet-Based Systems (SITIS)*, pages 435–441, 2016.
- [5] Matthew Barth and Kanok Boriboonsomsin. Energy and emissions impacts of a freeway-based dynamic eco-driving system. *Transportation Research Part D*, 14:400–410.
- [6] Makhmoor Bashir and Rajesh Verma. Why Business Model Innovation Is the New Competitive Advantage. *IUP Journal of Business Strategy*, 15(1):7–17, 2017.
- [7] Larry Blincoe, National Highway, and Traffic Safety. THE ECONOMIC AND SOCIETAL IMPACT OF MOTOR VEHICLE Larry Blincoe , National Highway Traffic Safety.

- [8] N. M P Bocken, S. W. Short, P. Rana, and S. Evans. A literature and practice review to develop sustainable business model archetypes. *Journal of Cleaner Production*, pages 42–56, 2014.
- [9] Sarah Bonnin, Thomas H. Weisswange, Franz Kummert, and Jens Schmuudderich. Accurate behavior prediction on highways based on a systematic combination of classifiers. *IEEE Intelligent Vehicles Symposium, Proceedings*, (Iv):242–249, 2013.
- [10] Brainrants. How to. understand and use npv in a business case - brainmates - boosting people and product performance.
- [11] H P Breivold and K Sandstroem. Internet of Things for Industrial Automation – Challenges and Technical Solutions. *2015 IEEE International Conference on Data Science and Data Intensive Systems*, pages 532–539, 2015.
- [12] Henning Breuer and Florian Lüdeke-Freund. Normative Innovation for Sustainable Business Models in Value Networks. *The Proceedings of XXV ISPIM Conference- Innovation for Sustainable Economy and Society*, (June):17, 2014.
- [13] Eva Bucherer and Dieter Uckelmann. 10 Business Models for the Internet of Things. *Architecting the Internet of Things*, pages 253–278, 2011.
- [14] BusinessDictionary. What is information system? definition and meaning - BusinessDictionary.com, 2016 Accessed: December21, 2016”.
- [15] German Castignani, Thierry Derrmann, and Thomas Engel. Driver Behavior Profiling using Smartphones : A Low-Cost Platform for Driver Monitoring. *IEEE Intelligent Trnasportation Systems Magazine*, 7(1):91–102, 2014.
- [16] German Castignani, Thierry Derrmann, and Thomas Engel. Driver Behavior Profiling using Smartphones : A Low-Cost Platform for Driver Monitoring. *IEEE Intelligent Trnasportation Systems Magazine*, (1):91–102, 2014.
- [17] CSCMP. SCM Definitions and Glossary of Terms, 2016.

- [18] Michael Hanford Daniel B Stang. Fleet Insurance - what you need to know — Blue-drop, 2009.
- [19] Pierre J. Dejax and Teodor Gabriel Crainic. Survey Paper A Review of Empty Flows and Fleet Management Models in Freight Transportation. *Transportation Science*, 21(4):227–248, 1987.
- [20] Deloitte. Every. Thing. Connected.
- [21] Department for Transport. The Fuel Efficient Truck Drivers’ Handbook. 2009.
- [22] R. M. Dijkman, B. Sprenkels, T. Peeters, and A. Janssen. Business models for the Internet of Things. *International Journal of Information Management*, 35(6):672–678, 2015.
- [23] R M Dijkman, B Sprenkels, T Peeters, and A Janssen. International Journal of Information Management Business models for the Internet of Things. *International Journal of Information Management*, 35(6):672–678, 2015.
- [24] Mihai DOINEA, Ctlin BOJA, Lorena BATAGAN, Cristian TOMA, and Marius POPA. Internet of Things Based Systems for Food Safety Management. *Informatica Economica*, 19(1):87–97, 2015.
- [25] Birsen Donmez, Linda Ng Boyle, and John D. Lee. Mitigating driver distraction with retrospective and concurrent feedback. *Accident Analysis and Prevention*, 40(2):776–786, 2008.
- [26] Richard C. Dorf and Robert H. Bishop. Proceedings of the 38th IEEE Conference on Decision and Control (Cat. No.99CH36304). *1999 Conference on Decision and Control*, (December):2679–2684, 1999.
- [27] Truck driving jobs. Truck Driving Accidents Causes, Fatalities, Statistics and Costs.
- [28] Dave Evans. The Internet of Things - How the Next Evolution of the Internet is Changing Everything. *CISCO white paper*, (April):1–11, 2011.

- [29] Peng-fei Fan and Guang-zhao Zhou. Analysis of the business model innovation of the technology of internet of things in postal logistics. *2011 IEEE 18th International Conference on Industrial Engineering and Engineering Management*, pages 532–536, 2011.
- [30] Fritz Institute. Fleet Management. pages 1–63, 2012.
- [31] Alfonso Gambardella and Anita M. McGahan. Business-model innovation: General purpose technologies and their implications for industry structure. *Long Range Planning*, 43(2-3):262–271, 2010.
- [32] Konstantinos N Giannoutakis and Feng Li. Making a Business Case for Intelligent Transport Systems : A Holistic Business Model Framework Making a Business Case for Intelligent Transport Systems : A Holistic Business Model Framework. 1647(July), 2017.
- [33] Sylwia Gierej. The Framework of Business Model in the Context of Industrial Internet of Things. *Procedia Engineering*, 182:206–212, 2017.
- [34] Richard Grace and Sonya Steward. Drowsy driver monitor and warning system. *International driving symposium on human factors in driver assessment, training and vehicle design*, pages 64–69, 2001.
- [35] Alan Grau. The Internet of Things The Internet of Things. page 6, 2013.
- [36] Reetu Gupta and Rahul Gupta. ABC of Internet of Things: Advancements, benefits, challenges, enablers and facilities of IoT. In *2016 Symposium on Colossal Data Analysis and Networking (CDAN)*, pages 1–5. IEEE, mar 2016.
- [37] N HAWORTH and Mark Symmons. THE RELATIONSHIP BETWEEN FUEL ECONOMY AND SAFETY OUTCOMES, 2001.
- [38] David Helman. Traffic Incident Management. *Public Roads*, pages 14–21, 2004.

- [39] Michael Henzler, Alisa Boller, Michael Buchholz, and Klaus Dietmeyer. Are Truck Drivers Ready to Save Fuel? the Objective and Subjective Effectiveness of an Ecological Driver Assistance System. *IEEE Conference on Intelligent Transportation Systems, Proceedings, ITSC*, 2015-Octob:2007–2012, 2015.
- [40] Jeffrey S Hickman and Richard J Hanowski. Use of a video monitoring approach to reduce at-risk driving behaviors in commercial vehicle operations. *Transportation Research Part F: Psychology and Behaviour*, 14(3):189–198, 2011.
- [41] Nils Høgevold, Göran Svensson, Beverly Wagner, Daniel J Petzer, HB Klopper, Juan Carlos Sosa-Varela, Carmen Padin-Fabeiro, and Carlos Ferro. Sustainable business models : Corporate reasons, economic effects, social boundaries, environmental actions and organizational challenges in sustainable business practices. *Baltic Journal of Management*, (3):357–380, 2014.
- [42] Intel Corporation. Building an Intelligent Transportation System with the Internet of Things (IoT). Technical report, 2014.
- [43] Investopedia. Insurance.
- [44] Mark W Johnson. Seizing the White Space.
- [45] Christopher A. Kahn and Catherine S. Gotschall. The economic and societal impact of motor vehicle crashes, 2010 (Revised). *Annals of Emergency Medicine*, 66(2):194–196, 2015.
- [46] Barbara Kitchenham. Procedures for performing systematic reviews. 2004.
- [47] Alan Lewis and Dan McKone. To Get More Value from Your Data, Sell It, 2016.
- [48] Daniel C. Lueck, Micah D. and Murray. Predicting Truck Crash Involvement : A 2011 Update. (April):1–2, 2011.
- [49] Mirjana Maksimović, Vladimir Vujović, and Enisa Omanović-Miklićanin. A Low Cost Internet of Things Solution for Traceability and Monitoring Food Safety During Transportation. (October 2016), 2015.

- [50] Zhe Mao, Xin-ping Yan, and Chao-zhong Wu. Driving Fatigue Identification Method Based on Physiological Signals. (10):1–7, 2014.
- [51] Kurt Matzler, Franz Bailom, Stephan Friedrich von den Eichen, and Thomas Kohler. Business model innovation: coffee triumphs for Nespresso. *Journal of Business Strategy*, (2):30–37, 2013.
- [52] Houda Mnasser and Mourad Abed. Towards an Intelligent Information System of Public Transportation. pages 75–81, 2013.
- [53] Husley Morgan. Why Trucking Companies Use The GPS Technology, 2014, Accessed: December 15, 2016.
- [54] Silvia De Nadai, Mauro Benza, Massimo D Incà, Francesco Parodi, and Roberto Sacile. A system of systems approach to evaluate at-risk human behaviour in the transport by road. pages 8–11, 2015.
- [55] Sharon Newnam and Richard Tay. Evaluation of a Fleet Safety Management Information System. 41(1):39–52, 2005.
- [56] NHTSA. Traffic Safety Facts. *Www-Nrd.Nhtsa.Dot.Gov*, (May):Volume: 2001, Issue: June, Pages: 232, 2009.
- [57] Rogelio Oliva and Robert Kallenberg. Managing the transition from products to services. *International Journal of Service Industry Management*, (2):160–172, 2005.
- [58] Trkman P., Budler M., and Groznik A. A business model approach to supply chain management. *Supply Chain Management*, 20(6):587–602, 2015.
- [59] a. Polychronopoulos, a. Amditis, and E. Bekiaris. Information data flow in AWAKE multi-sensor driver monitoring system. *IEEE Intelligent Vehicles Symposium, 2004*, pages 902–906, 2004.
- [60] Goldman Sachs. The average cost of IoT sensors is falling, 2016.
- [61] SAFETY CANADA LIMITED. Commercial Transportation Industry - Safety Canada.

- [62] M Sekar, M Moshirpour, J Serfontein, and B H Far. Performance enhancement of Behavior-Based Safety of fleet management systems. *2014 IEEE International Conference on Systems, Man, and Cybernetics (SMC)*, pages 3840–3845, 2014.
- [63] Sajjad Hussain Shah and Ilyas Yaqoob. A survey: Internet of Things (IOT) technologies, applications and challenges. In *2016 IEEE Smart Energy Grid Engineering (SEGE)*, volume i, pages 381–385. IEEE, aug 2016.
- [64] Dhananjay Singh, Gaurav Tripathi, and Antonio J. Jara. A survey of Internet-of-Things: Future vision, architecture, challenges and services. *2014 IEEE World Forum on Internet of Things, WF-IoT 2014*, (August):287–292, 2014.
- [65] Dirk Slama, Frank Puhlmann, Jim Morrish, and Rishi Bhandnagar. Enterprise IoT: Strategies and Best Practices for Connected Products and ... - Dirk Slama, Frank Puhlmann, Jim Morrish, Rishi M Bhatnagar - Google Books.
- [66] Enji Sun, Xingkai Zhang, and Zhongxue Li. Internet of things based 3D assisted driving system for trucks in mines. *Proceedings - 2011 4th International Conference on Information Management, Innovation Management and Industrial Engineering, ICIII 2011*, pages 510–513, 2011.
- [67] SYSCO. Sysco - SYSCO and Starbucks Sign Agreement Giving SYSCO Exclusive Foodservice Distribution Rights for Starbucks Products, 2003. Accessed: December 22, 2016.
- [68] Teletrac. The Real Effects of Engine Idle Time Why Businesses are Investing in GPS Software to Combat Idle Time — A Teletrac White Paper.
- [69] Tomer Toledo, Oren Musicant, and Tsippy Lotan. In-vehicle data recorders for monitoring and feedback on drivers’ behavior. *Transportation Research Part C: Emerging Technologies*, (3):320–331, 2008.
- [70] Alberta Transporta, R S A Canada, Commercial Insurance, and R S A Canada. Value in Safety. pages 1–4, 2011.

- [71] T Trego and D Murray. An Analysis of the Operational Costs of Trucking. . . . *Research Board 2010 Annual Meetings CD- . . .*, (September):2009–2010, 2010.
- [72] T Trego and Dan Murray. An Analysis of the Operational Costs of Trucking. . . . *Research Board 2010 Annual Meetings CD- . . .*, (September):2009–2010, 2010.
- [73] Dieter Uckelmann, Mark Harrison, and Florian Michahelles. Architecting the Internet of Things. *Architecting the Internet of Things*, (JANUARY):1–353, 2011.
- [74] Verdin Paul and Tackx Koen. Are You Creating or Capturing Value ? A dynamic framework for sustainable strategy Paul Verdin M-RCBG Associate Working Paper Series — No . 36. (0):0–19, 2015.
- [75] Ovidiu Vermesan and Peter Friess. *Internet of Things From Research and Innovation to Market Deployment*. 2014.
- [76] Markus Weinberger, Dominik Bilgeri, and Elgar Fleisch. IoT business models in an industrial context, 2016.
- [77] Mika Westerlund, Seppo Leminen, and Mervi Rajahonka. Designing Business Models for the Internet of Things. *Technology Innovation Management Review*, 4(7):5–14, 2014.
- [78] Zhu Yongjun, Zhu Xueli, and Zhu Shuxian. Intelligent transportation system based on Internet of Things. *World Automation Congress ( . . .*, 2012.
- [79] Miao Yun and Bu Yuxin. Research on the Architecture and Key Technology of Internet of Things (IoT) Applied on Smart Grid. *2010 International Conference on Advances in Energy Engineering (ICAEE)*,, pages 69–72, 2010.
- [80] Jucimara Zacarias Silveira and José Carlos Souza. Traffic Accidents: Their Impact on a Quality of Life Evaluation. *JSM Burns Trauma*, (1), 2017.
- [81] Min Zhang, Tao Yu, and Guo Fang Zhai. Smart Transport System Based on The Internet of Things. *Applied Mechanics and Materials*, 48-49:1073–1076, 2011.

- [82] C. Zott, Raphael Amit, and L. Massa. The Business Model: Recent Developments and Future Research. *Journal of Management*, 37(4):1019–1042, 2011.

## Appendix A Here is all tables for 2 Literature Reviews conducted for Safety Systems and IoT Applications

Year	Scope	Methods/ Technologies	Main Findings/Gaps
1999	Economic and social	IVDR(in vehicle data recorders)	<ul style="list-style-type: none"> <li>-Eliminating unwanted behavior by collecting data about the overall trip.</li> <li>-Crash data is a good approach in monitoring systems to be able to provide an accurate feedback.</li> <li>-The system is not an advance system as none of telecommunication or technology was used to send data.</li> <li>-The system is designed for heavy trucks mainly.</li> </ul>
2001	Economic and social	Video-based system	<ul style="list-style-type: none"> <li>-Works by computing the PERCLOS to determine if operator is sleeping</li> <li>-Feedback and alert giving to driver in voice form.</li> <li>-However, the size of the devices used might be inconvenient for the driver and hinder the user acceptance of the system.</li> <li>-The main gap in this system is only considering PERCOLS and ignoring other variables which may impact the eyes movements for driver such as the environment (specifically, the light)</li> <li>-The system is multifunctional.</li> </ul>
2004	Economic and social	Sensors and In vehicle Data	<ul style="list-style-type: none"> <li>-The system monitor driver and environment to reduce accidents, but not monitoring the vehicle.</li> <li>-Different parameters for operators are taking to ensure safety and systems accuracy.</li> <li>-Systems complexity and lack data accessibility by all interested parties are determined as system's weaknesses.</li> <li>-This work can be greatly enhanced in term of accuracy, consistency, reliability using other technological methods such as using cloud computing</li> <li>-The system is monitoring driver to reduce the risk of distractions while driving and provide a feedback in case if driver is distracted.</li> </ul>
2007	Economic and social	In Vehicle Data Recorder	<ul style="list-style-type: none"> <li>-The scope of the system is limited, only monitor the distraction and no other services provided to the users compared with other solution.</li> <li>-With the concurrent feedback is always recommended.</li> <li>-Different types of physiological signals are considered in the systems to enhance accuracy.</li> </ul>
2008	Economic and social	Sensors and video	<ul style="list-style-type: none"> <li>-No feedback or reaction is giving to the driver is found to be fatigued.</li> <li>-Due to the number of devices attached to driver this system is not convincing for drivers.</li> <li>-Its multi-usage system profiling driver's behaviour.</li> </ul>
2015	Economic and social	Smart-Phone sensors	<ul style="list-style-type: none"> <li>-The system can be adapted due to its effectiveness with IoT.</li> <li>-Real time feedback is missing in this system.</li> <li>-The system and its own subsystems work by monitoring the behavior of driver, environment and the vehicle to give a better understanding of specific action or event.</li> </ul>
2015	Economic and social	On-Board Diagnostic OBD, Bluetooth, sensors, web-cam	<ul style="list-style-type: none"> <li>-Physiological parameter [HR] only, which are used in driver monitoring are not accurate.</li> <li>-No feedback or alert is giving to driver.</li> <li>-The systems complexity is considered as a problem.</li> </ul>

Table 1: Driver Monitoring for Economic and Social Purposes

Year	Scope	Methods/ Technologies	Main Findings/Gaps
2000	Environmental	Data collection	<ul style="list-style-type: none"> <li>-This work found out the fuel based emission varied more than the emissions of time and distance.</li> <li>-Also found that the transitory driving modes, which include acceleration and deceleration contributing more to air pollution than steady speed one, such as idling.</li> <li>-There was no suggested system or feedback in this work to reduce the emission</li> <li>-The system is for also is considered as a safety system in its nature by adjusting the speed based on traffic status.</li> </ul>
2009	Environmental	Intelligent Speed Adaptation (ISA), consists of GPS, Algorithm and telematics	<ul style="list-style-type: none"> <li>-Real-time feedback based on Real-time data gathered by GPS about traffic and location help to make the system robust.</li> <li>-This system and such a system contributes to 10-20 percent of lowering fuel and emission.</li> <li>-The rate in which the operators received feedback about speed is not mentioned.</li> <li>-This solution is control based the human (truck driver) located in the control loop would be considered as challenge.</li> </ul>
2015	Environmental	Ecological Driver Assistance System,(EDAS), consists of digital maps, Human Machine Interface (HMI)	<ul style="list-style-type: none"> <li>-The result of this study showed that truck drivers are willing to reduce fuel consumption if they provided with EDAS, which in turn will result in less emission.</li> <li>-Feedback is giving to driver in order to adjust their driving performance is giving only in vibration mood</li> </ul>

Table 2: Driver Monitoring Systems for Environmental Purposes

Year	Area	Technology/Technology Enablers	Main Findings/Gaps
2011	Safety Systems in mines	IoT [sensors, RFID, camera, GPS]	<ul style="list-style-type: none"> <li>-The layers of the system are valuable and each one is design to perform specific task.</li> <li>-All the problems can be solve online and on time.</li> <li>-Any abnormalities occur will be stored in the server on the cloud.</li> <li>-Using Google earth is one of the systems strengths and help in achieving the goal of it.</li> <li>-According to the author the system is still needs some development.</li> </ul>
2012	Transportation	IoT [RFID, GPS, GRPS, GIS]	<ul style="list-style-type: none"> <li>- Using IoT approach to communicate and exchange data and information about buses tracking and monitoring.</li> <li>-The system has many subsystems to perform specific detailed functions such as anticipating the number of passengers.</li> </ul>
2014	Transportation	IoT [sensors and NFC, GSM]	<ul style="list-style-type: none"> <li>-The system shows a strong success using IoT in all the required aspects location, destination, payment, and environment.</li> <li>-Such a system is playing important role to reinforce smart cities theme.</li> <li>-The system is only designed for public transport, so it may nit be useful for other kind of commercial fleets.</li> <li>-Applying the IoT in new area.</li> </ul>
2015	Food Management and Logistics	IoT [sensors and RFID]	<ul style="list-style-type: none"> <li>- Application also allows consumers to access to data about food products.</li> <li>-The system would be a helpful tool, especially in countries where chemical substances used in farming and food product, so customers can know the process and activities related to the food.</li> <li>-Reduce food contamination.</li> <li>-Such a system can make a customer understand production process, and increase customers trust.</li> <li>-The system is designed based on economic requirement such as low cost and small size.</li> </ul>
2015	Food Industry and Supply Chain	IoT [sensors, RFID, GSM/GRPS, RPi]	<ul style="list-style-type: none"> <li>-Provides full automation to the process of traceability and monitoring in food transportation.</li> <li>-Raspberry Pi(RPi) is mentioned in the proposed system to be placed in every container/ cargo to ensure food safety with low cost.</li> <li>-Real-time alert is one benefit of this proposed system</li> </ul>

Table 3: IoT Literature Review

Appendix B Here is all of the data we used for the system simulation

Movement (prior to crash)	Frequency
Going Straight = 1	46.40%
Negotiate a Curve = 2	21.00%
Stop in traffic lane = 3	16.00%
Decelerate in traffic lane = 4	4.40%
Avoiding maneuver = 5	3.00%
Changing lanes = 6	2.10%
Turning left = 7	1.70%
Turning right = 8	0.60%
Accelerating in traffic lane = 9	1.40%
Passing another vehicle = 10	1.00%
Making U turn = 11	0.20%
Other = 12	2.20%
<b>TOTAL</b>	<b>100.00%</b>

Figure 1: Data Collection Table 1

Reason of Pre-Crash event	Movement	Frequency
<b>Recognition Error = 1</b>	Inadequate surveillance	20.30%
	Internal distraction	10.70%
	External distraction	3.80%
	Inattention	3.20%
	Other	2.50%
<b>Decision Error = 2</b>	Too fast for conditions	8.40%
	Too fast for curve	4.90%
	False assumption	4.50%
	Illegal maneuver	3.80%
	Misjudgement on speed	3.20%
	Following too closely	1.50%
	Aggressive driving	1.50%
	Other	6.20%
<b>Performance Error = 3</b>	Overcompensation	4.90%
	Poor direction control	4.70%
	Panic or freezing	0.30%
	Other	0.40%
<b>Non Performance Error = 4</b>	Sleep or asleep	3.20%
	Heart attack/impairment	2.40%
	Aggressive driving	1.60%

Figure 2: Data Collection Table 2

Appendix C Here is the additional data we used for the business model

Probability estimates (Hdata)	Events (Death/injuries Month)
0.3	<=2
0.6	]2; 8[
0.1	>=8
	mean u=4.3
Probability estimates (IOT)	Events (Death/injuries Month)
0.202810993	<=2
0.76715085	]2; 8[
0.030038156	>=8
	mean u= 0.99%*4.3

Figure 3: Data Collection Table 3

Crashes Table 1. Fatal Crashes Involving Large Trucks						
First Harmful Event	2012		2013		2014	
	Number	Percent	Number	Percent	Number	Percent
Collision with Vehicle in Transport	#####	73.8%	#####	72.4%	#####	72.8%
Collision with Fixed Object	350	10.0%	349	9.8%	335	9.8%
Collision with Pedestrian	253	7.3%	284	8.0%	257	7.5%
Overturn (Rollover)	153	4.4%	166	4.7%	156	4.6%
Collision with Pedalcycle or Other Personal Conveyance	72	2.1%	89	2.5%	70	2.0%
Collision with Parked Motor Vehicle	34	1.0%	33	0.9%	41	1.2%
Collision with Train	9	0.3%	14	0.4%	19	0.6%
Collision with Other Object	7	0.2%	9	0.3%	7	0.2%
Collision with Animal	8	0.2%	6	0.2%	7	0.2%
Explosion/Fire	0	0.0%	1	*	0	0.0%
Jackknife	2	0.1%	9	0.3%	8	0.2%
Pavement Surface Irregularity	0	0.0%	0	0.0%	0	0.0%
Cargo Equipment Loss or Shift	1	*	3	0.1%	10	0.3%
Other	23	0.7%	17	0.5%	20	0.6%
<b>Total</b>	<b>#####</b>	<b>100.0%</b>	<b>#####</b>	<b>100.0%</b>	<b>#####</b>	<b>100.0%</b>

Figure 4: Data Collection Table 4

Nature of the error (car-truck crash)	Frequency
Vehicule Failure = 1	7.00%
Brake = 2	27.00%
Unfamiliarity with road = 3	19.00%
Pressure feeling = 4	10.00%
Fatigue = 5	7.00%
Tire Problems = 6	3.00%
Agressive driving = 7	5.00%
Driver illeness= 8	1.00%
Illegal drug use = 9	0.40%
Alcohol use = 10	0.30%
Roadway = 11	5.10%
Weather= 12	4.40%
Other reasons (environment)= 13	10.80%
<b>TOTAL</b>	<b>100.00%</b>

Figure 5: Data Collection Table 5

Fatality rate (truck crash, 2009)	Frequency
Fatality = 1	1.00%
Brake = 2	99.00%
<b>TOTAL</b>	<b>100.00%</b>

Figure 6: Data Collection Table 6

Overhead annual cost (3 type of sensors)	A	B	C	
Set up cost	199.5	199.47	199.47	
Receiving cost	172.9	518.63	259.32	
Orders Cost	45.76	343.21	1372.8	
Insurance cost	134.6	242.36	323.15	
Maintenance cost	359.1	359.05	359.05	
Utilities cost	463.8	834.8	1113.1	
<b>Total overhead</b>	<b>1376</b>	<b>2497.5</b>	<b>3626.9</b>	<b>7500.002</b>
(All costs are estimated average values from similar devices)				

Figure 7: IoT Application Costs

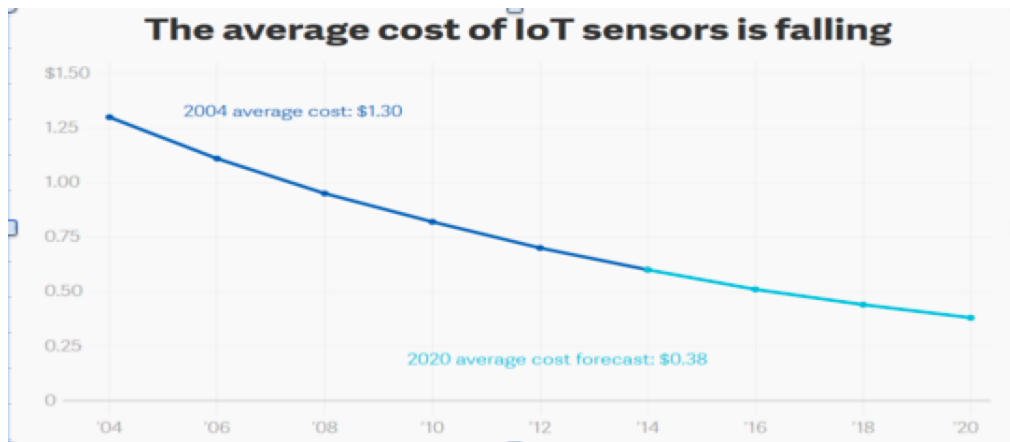

Figure 8: Average Sensor Costs [60]