

Radio over Fibre Passive Optical Network Integration for the Smart Grid

Majed Jarrar

Thesis submitted to the
Faculty of Graduate and Postdoctoral Studies
in partial fulfillment of the requirements for the
MAsc Degree in Electrical and Computer Engineering

Ottawa-Carleton Institute for Electrical and Computer Engineering
School of Electrical Engineering and Computer Science
Faculty of Engineering
University of Ottawa

© Majed Jarrar, Ottawa, Canada, 2015

Abstract

During the last three decades, the significant increase in electricity demand, and its consequences, has appeared as a serious concern for the utility companies, but no major changes have been applied to the conventional power grid infrastructure. Recently, researchers have identified efficient control and power distribution mechanisms as the immediate challenges for conventional power grids. The next step for conventional power grid towards the Smart Grid is to provide energy efficiency management along with higher reliability via smart services, in which the application of Information and Communication Technology (ICT) is inevitable. ICT introduces powerful tools to comply with the smart grid requirements. Among various ICT properties, the telecommunication network plays a key role for providing a secure infrastructure. The two-way digital communication system provides an interaction between energy suppliers and consumers for managing, controlling and optimizing energy distribution. We can also define the smart grid as a two-way flow of energy and control information, where the electricity consumers can generate energy using green energy resources. The main objective of this thesis is to select an effective data communication infrastructure to support the smart grid services by considering a hybrid wireless and optical communication technologies. Radio-over-Fibre (RoF) networks are considered as a potential solution to provide a fast, reliable and efficient network backbone with the optical access network integration and the flexibility and mobility of the wireless network. Therefore, we adopt the integration of RoF to Passive Optical Network (PON) as a broadband access network to transmit smart grid data along with the Fiber to the Home/Building/Curb (FTTx) traffic through the shared fibre, and utilizing Wavelength Division Multiplexing (WDM). Finally, we present and analyze the simulation results for the aforementioned infrastructure based on our enhanced ROF-PON integration model.

Acknowledgements

I would like to offer special thanks to my thesis supervisor, Professor H. Mouftah, for his remarkable professional guidance and personal support during my journey on this research. He challenged me to think outside the box, gave me hope when I ran into – many – bumps and dead ends, and believed in me more than I did in myself.

I also thank Dr. Khaled Maamoun who was so generous with his time and ideas, often working with me on a regular basis. Discussions over the phone until late night with him helped me to shape, direct, redirect and complete this thesis.

I am grateful for the contribution of my wife, Tessa Santoni, whose artistic talents helped me design most of my illustrations and block diagrams.

Finally, I would like to thank my good friend Tarek Refaat for his help in proofreading and encouragement all along the way.

Dedication

*I dedicate this thesis to my mother, Fayza Al-Araji, for her
steadfast support and patience throughout my life,*

*To my father, Azzam Jarrar, for encouraging me to come to
Canada to pursue my studies, and to his ongoing support,*

*To my wife, Tessa Santoni, for all her patience and support all
the way,*

To my son, Elias Jarrar; the apple of my eye.

Contents

List of Figures	viii
List of Tables	x
List of Acronyms	xi
List of Publications.....	xvi
Chapter 1. Introduction	1
1.1 Background	1
1.2 Motivation.....	2
1.3 Objectives.....	6
1.4 Contributions.....	6
1.5 Thesis Outline.....	7
Chapter 2. The Smart Grid and Radio over Fibre	8
2.1 Introduction	8
2.2 The Future Smart Grid.....	9
2.2.1 Smart Distribution	11
2.2.2 Smart Homes	12
2.2.3 Plug in Electric Vehicles	14
2.2.4 Smart Energy Generation, Transmission and Distribution.....	16

2.3	Smart Grid Enabling Technologies	18
2.3.1	Passive Optical Networks	18
2.3.2	Wireless Sensor Networks.....	18
2.4	Smart Grid Enabling Features	19
2.4.1	Smart Grid Security.....	19
2.4.2	Smart Standardization	19
2.5	Fibre-Wireless State-of-the-Art.....	20
2.5.1	Related Works on RoF-PON.....	24
2.6	Summary	30
Chapter 3. RoF-PON Network Integration for the Smart Grid		31
3.1	Introduction	31
3.2	RoF-PON for Smart Grid Access Network	34
3.2.1	Mach-Zehnder Modulation	38
3.2.2	Remote Heterodyne Detection	40
3.2.3	The Ku Band for Wireless Data Communication	42
3.3	RoF PON for Neighbourhood Area Network.....	43
3.3.1	Ring RoF-PON	43
3.3.2	RoF-PON and the Internet of Things	44

3.3.3	Survivability	46
3.4	Summary	49
Chapter 4.	Simulation and Performance Results	50
4.1	Introduction	50
4.2	Simulation Settings and Assumptions.....	50
4.3	Performance Results	54
4.4	Summary	60
Chapter 5.	Conclusion and Future Work.....	61
5.1	Concluding Remarks.....	61
5.2	Future Research	63
References.....		65

LIST OF FIGURES

Figure 2-1 - Smart Grid Key Components.....	11
Figure 2-2 - Electric Vehicle Sales in the US.....	15
Figure 2-3 - Example RoF-PON Infrastructure in a MAN.....	25
Figure 2-4 – Simplified block diagram showing difference between (a) Analogue and (b) Digital RoF transmission and reception circuits.....	28
Figure 3-1 - RoF-PON in Smart Grid, yellow shows electric lines, and blue is for data connection	33
Figure 3-2 – The first RoF-PON model.....	36
Figure 3-3 - The Novel Enhancement to the RoF-PON	37
Figure 3-4 - Example of IoT Header in (a) typical IPv4 header showing (b) Smart Meter Flag.....	44
Figure 3-5 - Example of IoT Header in a typical (a) IPv6 header showing (b) smart meter flag.....	46
Figure 3-6 - Survivability model for (a) Ring-RoF-PON in the event of (b) fibre link failure (c) RAU node failure	48
Figure 4-1 - RoF-PON System Simulation with one node	50
Figure 4-2 - Inside the CS.....	51
Figure 4-3 - (a) inside the RAU and (b) inside the ONU	52

Figure 4-4 - RoF-PON Simulation parameters.....	53
Figure 4-5 - Ring ROF-PON for NAN	53
Figure 4-6 - ONU of a Ring-RoF-PON.....	54
Figure 4-7 - Pseudo-Randomly Generated Data	55
Figure 4-8 - The Modulated Optical Carrier at CS.....	55
Figure 4-9 - The Shifted Optical Carrier at ONU.....	56
Figure 4-10 - RF Current Generated by the Photodetector at the ONU.....	56
Figure 4-11 - The RF Signal Filtered Around 12.5 GHz.....	56
Figure 4-12 - The eye diagram of the received data at the RAU	57
Figure 4-13 - The eye diagrams in the first half of nodes on the ring RoF-PON network	58
Figure 4-14 - The eye diagrams of the second half of nodes on the ring RoF-PON network.....	59

LIST OF TABLES

Table 2-1 - Comparison between the three most common PON technologies.....	22
Table 3-1 - Summarized Comparison between RoF and R&F	33
Table 3-2 - Comparison of Different RoF Link Types.....	38

LIST OF ACRONYMS

AMI	Advanced Metering Infrastructure
AMR	Automated Meter Reading
ANSI	the American National Standards Institute
ARIN	American Registry for Internet Numbers
BEV	Battery-Electric Vehicles
CS	Central Station
DML	Directly Modulated Laser
DPSK	Differential Phase-Shift Keying
DSM	Demand Side Management
DWDM	Dense Wavelength-Division Multiplexing
E/O	Electro-Optical Modulator
EPON	Ethernet Passive Optical Network
ETSI	the European Telecommunications Standards Institute
Fi-Wi	Fiber-Wireless

FST	Fast Session Transfer
FTTA	Fiber to the Antenna
FTTx	Fibre to the Home/Business
FWM	Four Wave Mixing
GHG	Greenhouse Gas
GPON	Gigabit Passive Optical Network,
ICT	Information and Communication Technology
IEC	International Electrotechnical Commission
IEEE	the Institute for Electrical and Electronics Engineers
IoE	Internet of Energy
IoET	Internet of EveryThing,
IoT	Internet of Things
IP	Internet Protocol
IPv4	IP version 4

IPv6	IP version 6
ISP	Internet Service Provider
LTE	Long Term Evolution
M2M	Machine-to-Machine
MAN	Metropolitan Area Network
MIMO	Multiple-Input-Multiple-Output
MMF	Multimode Fibres
mmW	millimeter Wave
Mtoe	Million Tonnes of Oil Equivalent
MZM	Mach-Zehnder Modulator
NAN	Neighbourhood Area Network
NAT	Network Address Translator
NIST	the National Institute of Standards and Technology
O/E	Optical-to-Electrical

OFDM	Optical Frequency-Division-Multiplexing
ONU	Optical Network Units
OSI	Open Systems Interconnection
PEV	Plug-in Electric Vehicles
PHEV	Plug-in Hybrid Electric Vehicles
PHY	Physical Layer
PIN	P-type Intrinsic N-type Diode
PLC	Power Line Communication
PON	Passive Optical Network
QoE	Quality of Experience
QoS	Quality of Service
R&F	Radio-and-Fibre
RAU	Remote Antenna Unit
RHD	Remote Heterodyning Detection

RoF	Radio over Fibre
RSOA	Reflective Semiconductor Optical Amplifier
SCC	the Standards Council of Canada
SMF	Single-Mode Fibre
VHT	Very High Throughput
WDM	Wavelength Division Multiplexing
WLAN	Wireless Local Area Network
WMN	Wireless Mesh Network
WSN	Wireless Sensor Networks
XGM	Cross Gain Modulation
XPM	Cross Phase Modulation

LIST OF PUBLICATIONS

M. Jarrar, K. Maamoun and H. T. Mouftah, "An enhancement to the novel RoF-PON as a fibre-wireless services enabling technology", International Symposium on Performance Evaluation of Computer and Telecommunication Systems (SPECTS), Chicago, IL, July 26-30, 2015.

M. Jarrar, K. Maamoun and H.T. Mouftah, "Remote control and monitoring of home appliances", Proceedings, 5th Annual WiSense Workshop, University of Ottawa, Ottawa, August 2013, pp. 43.

M. Jarrar, K. Maamoun and H. T. Mouftah, "Novel Billing Method for Smart Meters", submitted.

Chapter 1. INTRODUCTION

1.1 BACKGROUND

The world consumption of energy has doubled over the past forty years. Fossil fuel reserves are in a fast decline, and humanity's thirst for advanced technology is non-quenchable. Current reports and research [1] [2] [3] show a serious concern about the impossibility for humanity to continue on the same way we are living. For these reasons, the academia, industry and governments began to work together to find an alternative, sustainable and bright future for our energy-dependent civilisation.

The largest problem we are faced with in the sector of energy is the lack of intelligent monitoring, communication and integration. These were the main reasons that caused the 2003 blackout, the largest power interruption in North American history, affecting nearly 60 million people in the US and Canada for nearly two full days [4]. Had this taken place during the freezing winter, it would have been one of the largest human catastrophes as well.

Therefore, we need a power grid with sustainable power generation facilities, reliable transmission and distribution networks, and intelligent control systems to ensure the continued growth of our advanced civilization. It is called the Smart Grid.

Today's technology revolution has brought an obsession with wireless technology. Wireless phones, internet, printers and TVs were just the beginning, and wireless charging

for even electric vehicles is already a reality [5]. It is understandable why this has become a key demand in today's fast-paced society. For the smart grid to be compatible with the future, it requires a data communication network that utilizes the flexibility of wireless technology, while ensuring that bandwidth, reliability and security are at maximum levels [6]. Therefore, as a main part of this thesis, we introduce Radio over Fibre (RoF) Passive Optical Network (PON) technology as infrastructure for the Smart Grid access network.

1.2 MOTIVATION

The main goal of this thesis is the improvement of the smart grid access network infrastructure. While there are numerous reasons for the importance of this research, the following are the major triggers.

FUTURE PROOF INFRASTRUCTURE

Engineers of the world have learnt many hard lessons when creating the internet, being the first mass scale data communication network. One of the greatest pitfalls that the internet faced – and is still facing – was the limited number in the Internet Protocol (IP) range of addresses. When IP version 4 (IPV4) was initially designed in 1981, engineers decided to allocate decimal addresses up to 255.255.255.255, hypothetically connecting 4,294,967,296 (2^{32}) devices. Back then the number meant infinity. Less than two decades later, the world was already starting to get squeezed with too many addresses.

Before the twentieth century ended, a makeshift solution was proposed under the name Network Address Translator (NAT). The solution consisted of mapping every group of

addresses – such as under one Internet Service Provider (ISP) – to one address on the public network. This way, all the nodes within the ISP will have their own domain and will not conflict with the rest of the world.

Obviously, this solution began to reach exhaustion and therefore a new IP version 6 (IPv6) was introduced [7], in which much greater capacity serving up to 2^{128} connected devices (approximately 3.4×10^{38} or 340 undecillion). According to the suggestion made by the American Registry for Internet Numbers (ARIN), all servers were expected to be ready to serve IPv6 clients by January 2012. However, the majority of the internet is still running on the older version due to the hardware upgrade requirements to servers. The switch is dragging slower than anticipated, and it's creating additional problems in privacy, availability and performance.

Therefore, the smart grid architects learnt from this painful and costly lesson, and decided to put on top of their priorities the emphasis on technologies that are flexible, easy to update protocols and future-proof.

LACK OF STANDARDIZATION

The issue of Smart Grid standardization has been a very critical issue since the early days of research. According to the International Electrotechnical Commission (IEC), there are numerous standardization development organizations for the smart grid, which their standardized elements are not compatible and sometimes conflict with each other. Even if the elements are carefully chosen to be technologically compatible, they will likely grow apart in the future. This is because of different interests, criteria and protocols which

govern the standardization process of each organization [3]. In their Smart Grid Standardization Roadmap report, the IEC demonstrates concern that not a single government has adopted a clear standardization strategy, to the point that even the term Smart Grid still does not have a unified meaning among stakeholders [8].

The smart grid needs a standardization model that is also future proof, not only in performance, but in customization and compatibility as well.

INTERNET OF THINGS

The simplest analogy to introduce the Smart Grid is to imagine the difference between computers without internet, and computers with internet. It is often seen as the Internet of Energy (IoE) [9]. Upon the implementation of the Smart Grid, it will be the largest real-life example of the Internet of Things (IoT). Not only will this be a great incentive for the future implementation of more IoT in other industries; but also the Smart Grid can, in fact, encompass most of these IoT.

SHORTAGE OF FOSSIL FUEL

During the period from 1972 to 2012, the total world consumption of energy has doubled. Energy production from fossil thermal, nuclear, hydro and all renewable forms of energy – soared from 4,672 Million Tonnes of Oil Equivalent (Mtoe) to 8,989 Mtoe [2]. The growth is expected to continue to rise exponentially. However, if continued on the same track, then in a matter of a few decades, the world will face a serious shortage of fossil fuels. The most mature alternative solution lies in the renewable energy technologies.

However, most renewable sources of energy require great complexity in operation control and integration with the grid; which current power control centres are not capable of handling.

By upgrading the power grid to a smart grid, there will be intelligent power control centres that could automatically handle the complexities of renewable energies. These smart control centres, along with smart transmission and distribution, all require a fast, reliable data communication network to operate upon, similar to the internet, but for the communication of smart grid data.

GREENHOUSE GAS EMISSIONS

The In the same time frame of the last statistic, the global carbon dioxide CO₂ emissions have also more than doubled. The figures soared from about 15,000 to 32,000 Teragrams CO₂ from 1972 to 2012 [1].

It has been found that electric power causes approximately 25% of global Greenhouse Gas (GHG) emissions. The utilities are concerned about the future of electricity systems; it is hoped that renewable and distributed generation will play a significant role in reducing GHG emissions. From grid perspective, these new generation modes require improved control and monitoring of existing networks. [10]

The Smart Grid will bring better utilization of current power generators, wider integration of renewable energy sources, and a more efficient optimization of the distribution and transmission infrastructure. These advancements will significantly curb GHG emissions and hence reduce industrial impact on the environment.

1.3 OBJECTIVES

With the advent of Smart grid, there is a focus of research activities that proposed numerous data communication infrastructure. However, as communication systems evolved becoming more complex and offering new capabilities, the requirements imposed on Smart Grid communication networks have changed as well. The objectives of this thesis are:

- (1) To explore different Smart Grid requirements for the data communication network
- (2) To study the integration of Fibre-Wireless networks
- (3) To investigate RoF-PON infrastructure and its corresponding features
- (4) To analyze how RoF-PON infrastructure can be implemented on the Smart Grid, and the resulting possible applications

1.4 CONTRIBUTIONS

The thesis research resulted in several contributions in the field of Information and Communication Technology (ICT) for improving the power grid at the Physical Layer (PHY) of the Open Systems Interconnection (OSI) Model.

The main contribution is a novel enhancement for the RoF on a PON architecture for the smart grid communication network, in which we cut the number of lasers in a RoF-PON system to half, while increasing the quality of the received signal using an improved technique of RHD that we devised.

The second contribution, more focused at the last mile problem. We proposed a Ring-RoF-PON network using the same improved technique of RHD at the level of the Neighbourhood Area Network (NAN) for smart meter data aggregation and smart home communication.

Additional contributions were achieved through creating a survivability model for optical link failure in RoF-Ring-PON and proposing a novel billing system for smart meters data communication.

1.5 THESIS OUTLINE

The thesis is organized as follows: Chapter 2 provides background information on Radio-over-Fibre and also a review of integrated fibre-wireless telecommunication networks in the smart grid. In Chapter 3 we present our adopted system model by considering the contribution of ICT to the power grid. In that chapter we also adopt the RoF-PON broadband access network technology. Chapter 4 presents the simulation assumptions and results, within the provided constraints, in simulation settings, and also analyzes the performance of the adopted system model. Our work concludes in Chapter 5 where we also describe some future research opportunities.

Chapter 2. THE SMART GRID AND RADIO OVER FIBRE

2.1 INTRODUCTION

The significant growth in electricity demand and GHG emissions which combined with the fast decline in fossil fuel reserves, which we described in the previous chapter, have all led the world leaders – in governments, academia, and industry to concentrate their efforts to develop an exit strategy from the current scenario. Proposed solutions from governments included higher carbon taxes, incentives for cleaner and greener factories and a number of international agreements and protocols. The most notable governmental achievement is the 1997 Kyoto protocol, which is a international treaty signed by 83 countries committed to reducing their GHG emissions up to 20% by the year 2020.

On the industry level, the proposed solutions included eco-friendly product lines, socially-responsible awareness campaigns, and most importantly self-restraining regulations regarding power conservation and GHG emissions limits. A notable example of corporate commitment, the engineers behind Mercedes S-Class, despite being known for its large engine and performance, committed themselves to an environmental standard higher than most hybrid vehicles, and consequently their latest car was awarded the strict environmental certificate by the German Technical Inspection Association (TÜV), which most hybrid vehicles couldn't achieve [11].

As with every other engineering problem, the lion's share of solutions comes from the academia. Many solutions were proposed that ranged between quick fixes to long-

term frameworks for improving the electric grid. This chapter summarizes the most notable research in smart grid data communication infrastructure.

This chapter is structured as follows. Section 2.2 describes the technical vision of the future smart grid infrastructure and the physical requirements for implementing such a system with respect to distribution, generation, homes, and electric vehicles. In Section 2.3 we consider the telecommunication technology infrastructure for the smart grid communication system. Section 2.4 discusses some key features pertinent to the smart grid. Section 2.5 introduces the Fiber-Wireless (Fi-Wi) integrated network and we discuss its key advantages and main challenges. We also look in more focus at one type of Fi-Wi networks: RoF, and discuss the related technologies for this type of telecommunication network. Then, this section continues by providing and comparing previously conducted work on integrating RoF as a solution to the Smart Grid. Finally, a summary of the chapter is provided in Section 2.6.

2.2 THE FUTURE SMART GRID

The smart grid is the concept that encompasses all technologies, topologies, and approaches that make generation, transmission, and distribution of electricity to be organically intelligent for the purpose of maximizing the benefits of all involved stakeholders. Having been a major research topic for two decades, there has already been extensive and comprehensive works which provided a holistic vision of the grid [12], [13], [14] and [15].

Similar to all other smart technologies, like smart phones, smart TVs and smart watches, the term smart grid lacked from its start a clear definition, and is still lagging behind with respect to standardization. According to the International Electrotechnical Commission (IEC), one of the key initial barriers to standardization is to reach an agreement on clear definition of the technologies and components of the smart grid, but that wasn't easy to begin, and is yet to be completed [3]. The problem is that many countries rely on locally developed standards, which ultimately always reach a point of incompatibility with each other; either with the current devices and topologies, or on their future upgrades.

However, this seemingly clash of smart civilisations is actually a blessing in disguise. The flexibility of the smart grid concept has enabled thousands of researchers, scientists, engineers and policymakers to contribute a wide variety of technologies, topologies and laws to this concept. There have been numerous works which surveyed those differences. The most detailed survey has been by Xi, Satyajayant, Guoliang and Dejun who surveyed over 270 works on infrastructure, management and protection systems of the smart grid [16]. On the other hand, Galli, Scaglione and Wang examined nearly 160 papers in Power Line Communication (PLC) in the smart grid [17]. Wang, Xu and Khanna reviewed communication architectures in the smart grid [18]. Su, Rahimi-Eichi, Zeng and Chow, studied 92 papers for charging electric cars [19].

There are other surveys which covered specific topics within the smart grid. A survey for wireless communication technologies for the smart grid was presented in [20], another survey covered different communication networks for automation of the smart grid,

analyzing the pros and cons of each [21]. A survey for smart grid communication characteristics was presented in [22]. Smart grid communication techniques which guarantee availability were briefly discussed in [23]. Even cloud computing applications for the smart grid were surveyed in [24]. Figure 2-1 demonstrates the key components that we envision to define the Smart Grid.

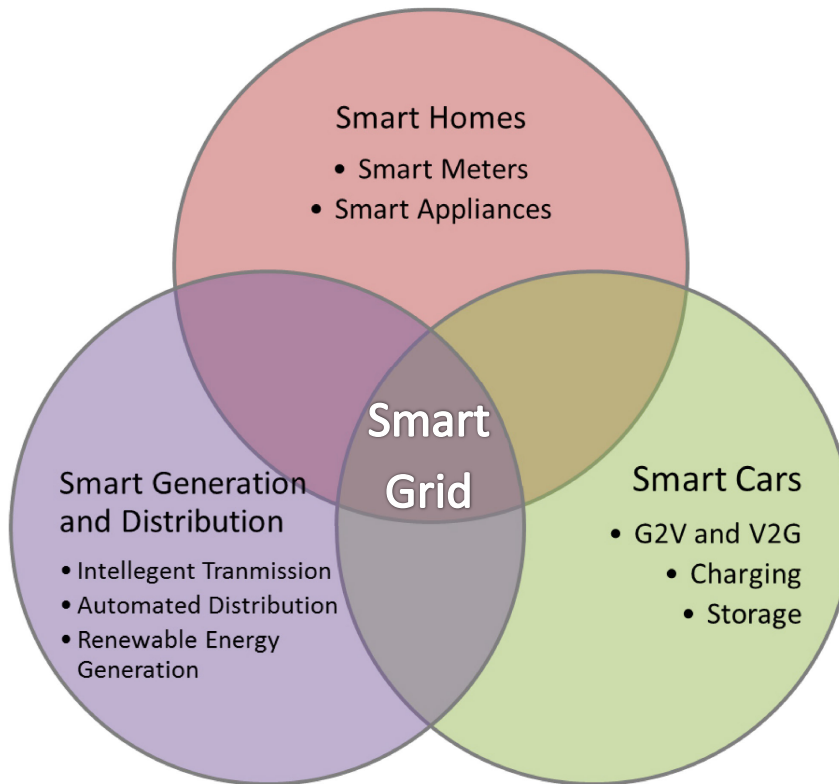

Figure 2-1 - Smart Grid Key Components

2.2.1 Smart Distribution

Smart distribution infrastructure is in fact an essential tool for optimizing the smart grid. The following works have laid strategies for the design, implementation, development and enhancement of the smart grid distribution infrastructure [25], [26], [27], [28].

The question of distribution inherently opens the door on compatibility. The smart grid will only become fully realized through the compatible integration of smart meters, homes and electric cars into the same power grid, under control and monitoring of intelligent generation and distribution systems. The integration of different Smart grid components was the focus of study in [29] and [30].

Social engineering plays an important part of smart distribution as well. With demand side management, governments and utility providers can create incentives and penalties through which they can predict the behavioural pattern of consumers, namely Demand Side Management (DSM). The following works have envisioned different methodologies to ensure an effective DSM in the smart grid [31], [32], [33] and [34].

2.2.2 Smart Homes

Smart homes provide monitoring and control over daily living activities. Examples of smart home features include ability to change the house temperature using a computer, checking if the stove is still on after leaving the house, or even find what is missing from the fridge. The path towards smart homes begins with smart meters.

2.2.2.1 Smart Meters

A smart meter (also known as an advanced meter) is the first cornerstone device in the smart grid. It is an electricity metering device that records customer consumption and other parameters in real-time, and provides daily (or more frequent) transmission of measurements over a data communication network to a central collection point either directly, or through aggregation with next-door meters over a ring network [35]. The need

of smart metering rose due to the increased variance and complexity in power consumption and electricity pricing throughout the day. By introducing real-time pricing through a smart meter, customers would be motivated use electricity less during peak hours and postpone running electric-heavy household appliances (such as dryer and dishwasher) to off-peak hours.

The main differentiator in an Advanced Metering Infrastructure (AMI) over the traditional Automated Meter Reading (AMR) is the establishment of a two-way communication between the utility provider and the customer [36].

AMI presents the biggest growth potential in the Machine-to-Machine (M2M) intelligence, in terms of numbers of devices connected. Smart meters will be expected not to require human intervention in characterizing power requirements and energy distribution. Fadlullah et. al discussed the future of smart meters, and surveyed the current M2M technologies that can be adopted for M2M communication in the smart grid [37].

SMART METER SECURITY

The greatest concern associated with smart meters is security. The process of introducing smart meters in the Netherlands between 2008 and 2011 came to a resounding failure when two consecutive smart meter bills were rejected by the Dutch First Chamber, due to wide popular concern related to privacy [38]. This became a textbook example taught regarding developing smart grid infrastructure. Smart grid commissions in numerous countries have noted that security concerns need to be addressed as thoroughly as technical concerns in the design process of the smart grid [39], [40], [41], [42].

There has been an abundance of works that have addressed security vulnerabilities in smart meters and have proposed solutions or mitigation techniques for them. A few surveys have already been authored reviewing those works, such as in [43], [44]. An important survey paper to note about smart grid security was authored by Jawurek, Kerschbaum and Danezis which presented an encompassing study addressing all available security options for the smart meter with a critical analysis for each one of them [45].

2.2.3 Plug in Electric Vehicles

There are two main types of Plug-in Electric Vehicles (PEVs):

1. Battery-Electric Vehicles (BEVs): these are all-electric cars that don't have an internal combustion engine or a fuel tank. Until the end of December 2014, the most sold car of this type worldwide is Nissan Leaf [46].
2. Plug-in Hybrid Electric Vehicles (PHEVs): these are cars that utilize a rechargeable battery which plugs in to the grid just like the BEV. However, it also has an internal combustion engine and a fuel tank. As of January 2015, the most sold car of this type worldwide is the Chevrolet Volt.

The market of plug-in vehicles (BEV and PHEV) has been growing remarkably since its debut in the US in December 2010. Despite the significant fall in gasoline prices in 2014, the PEV sales continued to grow, as seen in Figure 2-2. A comprehensive survey on technologies of PEV was presented in [19].

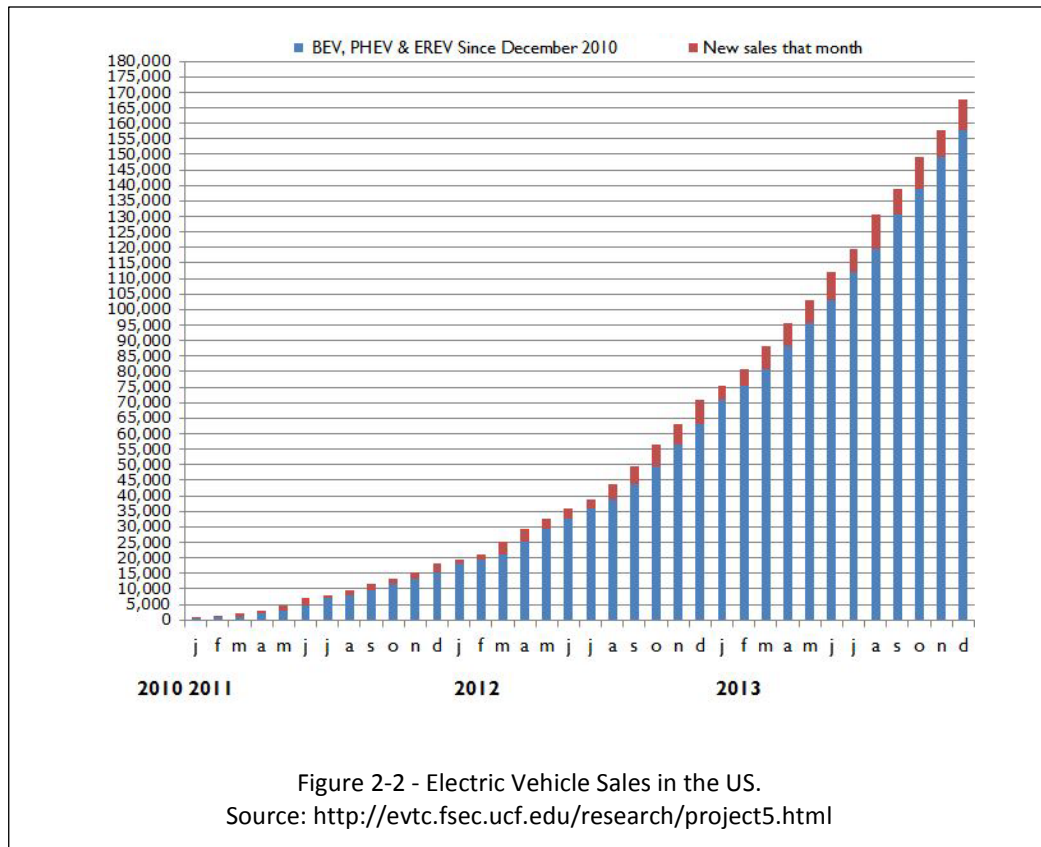

The introduction of PEVs brought a great challenge and a great opportunity to the smart grid. The challenge is to integrate and manage PEV charging load in the city, especially the residential areas, to avoid transformer overload resulting in power outages. The challenges of integrating PHEV into the residential distribution network were discussed in [47] and [48]. On a larger geographical impact, [49], [50], [51] and [52] have all discussed the impact of PHEVs on regional power generators and suggested practical solutions for the customers [53]. A more complex study was carried in [54] and [55] involving the dynamic effect of PHEVs on the grid with trip information and using advanced traffic modelling techniques.

Optimizing charging complexities is one of the greatest concerns for ensuring a promising future for electric cars in general [56], [57]. A detailed study [58] discussed the feasibility of solving this concern for the future of Ontario. The greatest challenge facing the growth and public adoption of electric vehicles are an efficient reliable integration of Vehicle to Grid (V2G) and a Grid to Vehicle (G2V) mechanism [59], [60].

2.2.4 Smart Energy Generation, Transmission and Distribution

The problem with all traditional models of electricity generation is that they follow a single deterministic model. This used to be very effective since generators were predictable. However, with the rising need for renewable energy sources, and having these sources being inherently unpredictable, the need arose for an intelligent model to control power generation.

A conservative solution is proposed in [61] which uses the existing infrastructure of power generation and transmission as base for intelligent features. On the other side, an innovative approach is taken in [62] that would require significant changes to the existing infrastructure. Nevertheless, the authors present a strong argument for the economic and technical incentives to make the leap.

In order to make electricity more affordable, reliable, and sustainable, the transmission of the electric grid must to become smarter. Many projects have focused on this area of research. Research areas include developing smart control centers, smart transmission networks, and smart substations, most of these were discussed in [63].

The features and functions of each of these functional components, as well as the enabling technologies to achieve these features and functions, need all to be compatible as well as integrated, not on the current technology only, but on the long run and large scale [25]. For that goal to be achieved, innovative technologies must be standardized to achieve an affordable, reliable, and sustainable delivery of electricity.

The smart grid brings an alternative to the traditional way distributed energy resources are managed through a sophisticated smart command and control systems. This smart system relies on the automation of numerous 'microgrids' in the distribution system that can implement smart functions such as improved reliability, high penetration of renewable sources, self-healing, active load control and improved generation efficiencies [27].

With a common digitalized platform, the smart generation, transmission and distribution grids will enable increased flexibility in control, operation, and expansion; allow for embedded intelligence, essentially foster the resilience and sustainability of the grids; and eventually benefit the customers with lower costs, improved services, and increased convenience. Since this thesis cannot encompass everything within the framework and vision of the smart grid, more research and development efforts are needed to fully integrate the smart grid framework through a joint effort of various entities.

2.3 SMART GRID ENABLING TECHNOLOGIES

2.3.1 Passive Optical Networks

According to leading research, there is no doubt that Fibre to the Home/Business (FTTx) will become the predominant broadband technology of choice in the next three decades [64], [65]. PONs play the key role in creating the most efficient and environmentally responsible point-to-multipoint FTTH because they offer huge capacity, small attenuation loss, low operational expenses, lowest energy consumption for broadband access. All these reasons and others make them future proof. More on PONs will be discussed in Chapter 3.

2.3.2 Wireless Sensor Networks

Wireless Sensor Networks (WSNs) have brought significant advantages over traditional communication technologies used in today's electric grid networks. Recently they have become a promising technology that can enhance various aspects of the grid, including generation, delivery, and utilization, making them a vital component of the Smart Grid. However, harsh and electrically-complex power-grid environments pose great challenges in the reliability of WSN communications in smart-grid applications. Gungor *et al.* [66] have presented a comprehensive experimental study on the statistical characterization of wireless channels in different electric-power-system environments, including a 500-kV substation, an industrial power control room, and an underground network transformer vault. Using WSNs is also crucial to implement many features in Smart Homes, and for demand side management.

2.4 SMART GRID ENABLING FEATURES

2.4.1 Smart Grid Security

Having learnt many lessons the hard way from the internet experience, engineers began the design of smart grid with security in mind. Several surveys in the field of security of the smart grid were published. The risks and assessment methods for cyber security of the smart grid were reviewed in [67]. Cyber security of the smart grid has also been examined by [68], but with more focus on attack prevention and defense strategies. Another cyber security survey was presented in [69], but enriched it with a study of the major challenges in implementation of cyber security solutions for smart grid communication.

2.4.2 Smart Standardization

Uslar *et al.* attempted to compile a comprehensive list of all standardization studies and recommendations and have published it in two parts [70], [71]. In Europe, a survey was published that described all regulatory developments that took place on a government level in the European Union [72].

On different scales of standardization, the work in [73] discussed the standardization methods of consumer applications with respect to smart homes. A generalized solution to lack of compatibility among different stakeholders was proposed in [74], which implements micro grids.

Numerous standardization organizations exist today. Most famously are the International Electrotechnical Commission (IEC), the Institute for Electrical and Electronics Engineers (IEEE), the American National Standards Institute (ANSI), the National Institute of Standards and Technology (NIST), the Standards Council of Canada (SCC), the European Telecommunications Standards Institute (ETSI), the European Committee for Electrotechnical Standardization (CENELEC). All of these organizations have produced either major standards or standardization roadmaps for the Smart Grid. Unfortunately, the level of cooperation among them is very limited. No government in the world has yet adopted any standardization roadmap drafted by these organizations.

Therefore, any proposed infrastructure for the smart grid must be protocol transparent and standardization flexible as the only way to become future proof.

2.5 FIBRE-WIRELESS STATE-OF-THE-ART

The wireless hype that has been going in the world has also been accompanied by another exploding demand: bandwidth. There is one conceptual problem though; the two are contradictory in nature. Wireless networks are inherently associated with scattered signal, reduced performance, and narrow bandwidth when compared to wired networks.

In order to increase wireless network performance and user capacity, frequency needs to be increased. Increasing frequency would increase the energy loss in transmission and hence significantly reduce the range. To overcome this, more cells are introduced, resulting in higher system cost. In order to suppress the system cost, small antenna circuits

have become more desirable. When antenna circuits are reduced to simple circuits, more complexity builds up in the signal processing at the central core of the network. To prevent the complexity from reducing overall network performance, the links between the antennas and the central station (CS) should have high bandwidth and low latency, hence optical fibre is utilized.

The parallel demand of both mobility and bandwidth puts more pressure on researchers to create integrated solutions that fuse the two, as Fi-Wi integration. There are plenty of experiments to integrate optical networks such as Ethernet Passive Optical Network (EPON), Gigabit Passive Optical Network (GPON), and Wavelength Division Multiplexing (WDM)-PON using wireless technologies such as WiMAX, 3G and LTE. Table 2-1 compares between those three PON architectures. The rich amount of contribution in this topic indicates that Fi-Wi integration is a promising area of research, as will be explained later in this chapter.

The last mile access problem has been typically the bandwidth bottleneck in communication networks. With fibre networks, the last mile becomes a more severe gap between ultra-fast optical transmission, and lagging coaxial or copper cables. Fi-Wi brought a ground-breaking solution to the last mile problem. For example, a wireless communication network based on Long Term Evolution (LTE) is an appropriate and effective solution for the last mile problem in the smart grid. Taking full advantage of fiber resources in power system, the RoF-based distributed network can be used as wireless access network for smart grid, which has the characters of high bandwidth, low loss, low-cost,

simple structure and dynamically allocated bandwidth. The wireless network can improve the signal quality in cell edge, and expand the coverage, which is an effective wireless access mean to improve wireless network capacity, as well as survivability.

Table 2-1 - Comparison between the three most common PON technologies, derived from [96]

	EPON	GPON	WDM-PON
Standard	IEEE 802.3-2008	ITU G.984	ITU G.983
Data Packet Cell Size	1518 bytes	53 to 1518 bytes	Independent
Maximum Downstream Line Rate	1.2 Gbps	2.4 Gbps	1-10 Gbits per channel
Maximum Upstream Line Rate	1.2 Gbps	1.2 Gbps	1-10 Gbits per channel
Downstream wavelength	1550 nm	1490 /1550 nm	Individual wavelength/channel
Upstream wavelength	1310 nm	1310 nm	Individual wavelength/channel
Traffic Modes	Ethernet	Varies	Protocol Independent
Voice	VoIP	TDM	Independent
Max PON Splits	32	64	16/100's
Max Distance	20 Km	60 Km	20 Km
Average Bandwidth per User	60 Mbit/s	40 Mbit/s	Up to 10 Gbit/s

The utilized access network technology with the features of large capacity, long transmission distance, low-cost and full-service support is PON. Since the current PON network, which is already built, can be used as backhaul network for the smart grid, the investment is retained, and the communication performance can be guaranteed for decades to follow. According to the transmission experiments [75], LTE networks has characters of low latency and high bandwidth, and can meet and exceed wireless communications needs of applications in smart grid. The proposed new generation wireless communications system is an effective solution for wireless communications in smart grid.

Another approach to solve the last mile problem is to use Cognitive Radio, utilizing the RoF with Multiple-Input-Multiple-Output (MIMO) technology. Some examples of performance calculation using simulation analyses are introduced in [76]. The propagation performance and simultaneous user capacity are both improved from LTE. However, the problem with cognitive radio is centralization of the control load on one hub, which doesn't go with the organic nature of the smart grid, where each node can be both a consumer and provider of electric power.

A journal paper [77] had presented a hybrid wireless-optical broadband-access network (WOBAN) as a promising architecture for future access networks. Their arguments for Fi-Wi integration are very strong. However, it doesn't fully satisfy the requirements for a smart grid access network due to potential risks in network complexity, latency and cost. Last but not least, Ghazisaidi and Maier discussed the upcoming challenges and opportunities facing Fi-Wi access networks in [78].

The strength of RoF candidacy over other Fi-Wi solutions for the smart grid access network comes from its ability to overcome most of those challenges mentioned. Additionally, the protocol transparency it provides for the wireless link enables us to use LTE now and possibly something completely different and much greater in the future, without any physical change to the infrastructure of the access network. It is the ultimate form of future proofing the wireless access evolution in a Fi-Wi network.

While these advantages may also be found in Radio-and-Fibre (R&F), we have decided to choose RoF for reasons explained in Chapter 3.

2.5.1 Related Works on RoF-PON

Having agreed on the advantages of the optical fibre communication and wireless communication technologies, RoF is a strong prospect to solve the problems of bandwidth flexibility and electromagnetic interference, while keeping the infrastructure costs significantly lower than other competing technologies [79]. With the rolling of more Smart Grid services, requirements such as bandwidth, stability and access reliability will increase greatly on the network. The existing data communication status and characteristics lead us to see that RoF will be the most cost-effective way to efficiently combine the advantages of both fibre and wireless networks.

The earliest works on RoF were introduced over twenty years ago by Cooper *et al.* [80] but didn't get much attention in the industry until the mid-2000s when the demand for ultra-high bandwidth as well as mobility reached unprecedented levels. However, those demands were scattered across the city in peak areas such as airports, malls, conference

centres and eventually office buildings and homes [81]. As researchers began to look for solutions to meet these rising demands, RoF became one of the top trending research areas in that year [82], [83], [84], [85], [86], [87], [88], [89], [90], [91]. Figure 2-3 shows an example of a RoF-PON architecture in a Metropolitan Area Network (MAN)

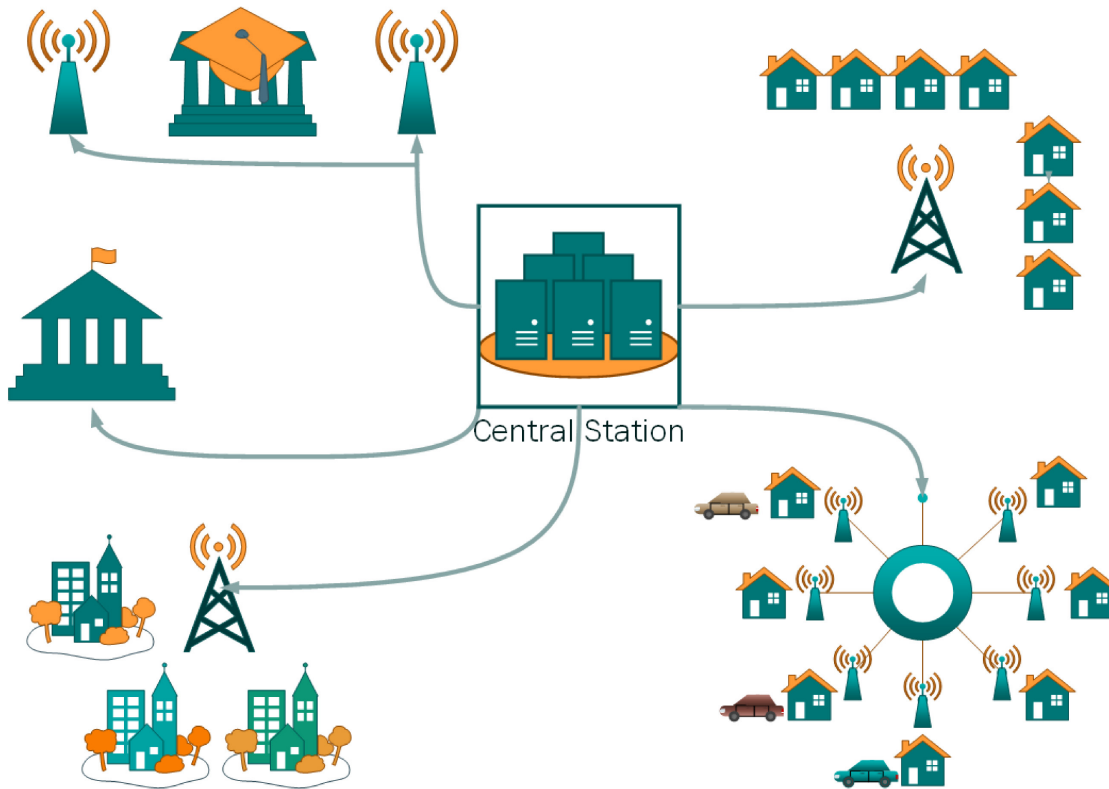

Figure 2-3 - Example RoF-PON Infrastructure in a MAN

To put the QoS of RoF to test, an experimental study was conducted in [92] demonstrated the transmission of uncompressed 1.3 Gb/s HD video over a RoF network of 60 GHz millimeter Wave (mmW) band and 25 km of SMF, and a picocellular wireless radius of approximately 5 meters, the results show superior performance in terms of QoS.

Very few works have been carried in the ring network topology; a key paper worth mentioning is by Lu *et al*, who proposed and demonstrated a full duplex WDM- Ring-RoF long-haul network with very low BER [93].

The possibility of creating a picocellular network using RoF network architecture was discussed in [94], utilizing different Multimode Fibres (MMFs) and a standard Single-Mode Fibre (SMF), with IEEE 802.11 a/b/g standard for wireless connectivity. The paper was a breakthrough in showing that RoF can perform at distances over 30 km at SMF with 5.8-GHz Wireless Local Area Network (WLAN) signals. Then, authors conducted an experimental implementation of a RoF picocellular network in which it proved that RoF can meet all the IEEE 802.11 a/b/g standard requirements in terms of noise, gain and dynamic range.

Some research work has been done to show the viability of the integration of RoF in PON networks [95] [96] [97]. Needless to say, PONs are more efficient and reliable than active optical networks because they have no active equipment. Other research papers have experimented with RoF in WDM network infrastructure and have proved the capability of WDM-RoF to provide point-to-multipoint and multipoint-to-multipoint communication in a reliable and cost effective way [87] [98] [91] [83] [84].

Several designs of RoF link types, depending on method of integrating the fibre network with the wireless network, have been discussed with advantages and disadvantages of each type in [99] and in more depth in [100].

More recently, a journal paper simulated a successful transmission of bidirectional 16 Gbps over 25 km 16 channel WDM-RoF-PON [101]. Similar simulations were carried out in [102], [103], [104] [105] [106] [107] which all proved the effectiveness of using WDM-RoF-PON as a reliable, high-performing, large scale access network.

Our proposed implementation for Fi-Wi integration is the RoF-PON access network. RoF-PON features a centralized infrastructure with simple and robust Optical Network Units (ONUs). The ONU does not need to have expensive radio equipment found in most other Fi-Wi integrations, making it easy to replicate. The economics of scale makes RoF-PON one of the most convenient and affordable Fi-Wi integration technologies to be adopted in mass deployment. This led one of the leading telecom operators in North America to commit to installing over 3,000 RoF systems across malls and subway stations [108].

Additionally, some research has been done to show RoF performance in both digital and analog encoding (Figure 2-4), a basic study in BER comparison was carried by Ballal and Nema in [109]. The comparison was recently carried with significant development by Haddad and Gagnaire, in which not only technical comparison was better defined, but they also included economical comparison [110]. To put it in simplest forms, digital RoF has superior QoS than Analogue, at the expense of slightly added cost and complexity in the RAU.

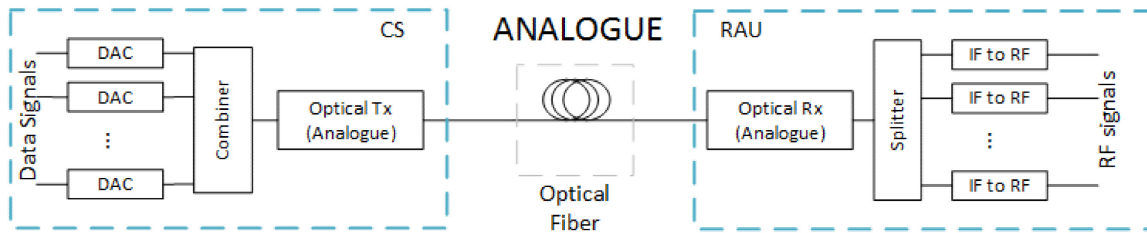

(a) Analogue RoF

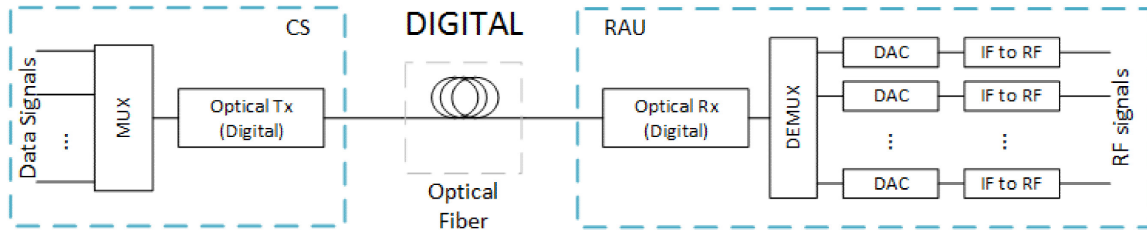

(b) Digital RoF

Figure 2-4 – Simplified block diagram showing difference between (a) Analogue and (b) Digital RoF transmission and reception circuits

There are other ways to tackle the optimization problem of channel capacity versus system cost. One example is to utilize Dense Wavelength-Division Multiplexing on a Passive Optical Network (DWDM-PON) to integrate with the wireless network [111]. More will be discussed in the next chapter.

Recently, research has become focused on Fi-Wi integration as an appealing solution for Smart Grid. However, there have been very few works dedicated to researching RoF specifically as a smart grid access network; because it wasn't efficient to do so until research in mmW RoF was introduced.

The first mention of RoF as a possible solution for the Smart Grid was made less than 4 years ago in a general study about next gen wireless technologies for the smart grid [75]. After that paper, a small amount of individual research was conducted. Xu carried an

experimental study in which he successfully broadcasted three-way video transmission near transformer substations over RoF with a large 1.2 km wireless coverage [112]. Another paper carried an experiment for RoF as a solution for university- or community-sized smart grid [76].

The first in depth study to implement RoF in Smart Grids, although specific to Smart Homes only, was a PhD thesis in late 2012 [113]. The researcher used 60 GHz channel (IEEE 802.11ad and WirelessHD) as wireless standards, and he compared their advantages and disadvantages. He then critically assessed their short range challenges. Since the signals resulting from these radio standards have short ranges due to high attenuation they are unlikely to cross any walls, hence they would be limited to one room or open indoor area per antenna. Then mitigation technologies were discussed such as Fast Session Transfer (FST), Beamforming, Relay and finally, EPON links between access points. None of these methods were ultimately the best, as each had their own advantages and disadvantages. The network architect should decide which technology to use when rolling out the infrastructure to the house(s). All the architectures above have achieved a transmission bandwidth at 2.856 Gbps PHY rate and 1.904 Gbps MAC rate. To demonstrate, a Blu-ray full HD movie was displayed on a large full HD screen using duplex RoF, all of the architectures proposed displayed the movie smoothly and none had any issues with the Quality of Experience (QoE).

The RoF multipoint-to-multipoint architecture based on technology transparent optical components brings a balance between performance and cost, but only if it is

completed by a management of the optical access. It has been proposed to activate the optical functions of the RoF only when and where they are needed to never have two lasers emitting or two photodetectors receiving at the same time, in order to minimize noise.

2.6 SUMMARY

The future of the Smart Grid depends on the realization of the appropriate data network. The fast growth of data communication is led by two main trends: the proliferation of wireless connected devices and the deployment of high broadband optical access networks, FTTx which allows the delivery of multiple services at Gbps speeds. As a consequence, to ensure efficient smart grid communication while guaranteeing reliability, low latency, high flexibility, high QoS for substations and high QoE for users, the Smart Grid has to be equipped with a data network that can meet or exceed all those demands, such as the Fi-Wi infrastructure.

The Smart Grid is the convergence point of several worlds: power generators, computers, control stations, consumer electronics, meters, etc. Consequently, the need for high capacity is not the only problem, but the great heterogeneity of the signals and their requirements to be delivered to the various elements of the grid. And for an expensive long-lasting infrastructure like an optical system, smart grid infrastructure must take into account a large variety of services to be emerged.

Users will enjoy the flexibility of wireless connectivity for the final link to their devices, most of which today require Very High Throughput (VHT) wireless solutions, and the network will be reliable, secure and future proof with the fibre infrastructure.

We have demonstrated in this chapter that there is a huge potential for RoF-PON infrastructure, that the smart grid is still lacking a comprehensive and standardized solution which has a high level of protocol transparency and technology flexibility, that RoF-PON has excellent compatibility prospects – in comparison to other Fi-Wi technologies – with smart grid evolution needs, and that this integration of RoF in Smart Grid is an increasingly appealing topic in both academia and industry.

Chapter 3. ROF-PON NETWORK INTEGRATION FOR THE SMART GRID

3.1 INTRODUCTION

It has become apparent from the previous chapter that the Smart Grid is the unanimous direction by governments, industry and academia for the advancement of the electric grid.

Networks architects nowadays demand on the top of their list of requirements to have highest bandwidth, availability, simplicity, reliability with lowest cost. With the integration of fibre-wireless, this challenging set of requirements has become an achievable reality. We have considered several fiber-wireless networks as enabling

technologies for fibre-wireless integration. We have decided to set on the RoF technology, due to its simplicity and cost effectiveness. Figure 3-1 shows our vision for the implementation of our proposed system.

This chapter focuses on system architecture and requirements. We propose a telecommunication infrastructure solution which has the properties of being extremely flexible, simple, cost effective, reliable and survivable in order to meet the required communication infrastructure expectations for the smart grid, in normal as well as extreme (e.g. stormy) conditions. Section 3.2 describes the proposed RoF-PON infrastructure for meeting the requirements of the access network that collects and manages the different smart grid data among sensors, consumers and utility providers. In this section we also explain the optical signal detection method used. Section 3.2.3 describes our implementation of RoF-PON over NAN. It also discusses the impact this implementation will create for the IoT.

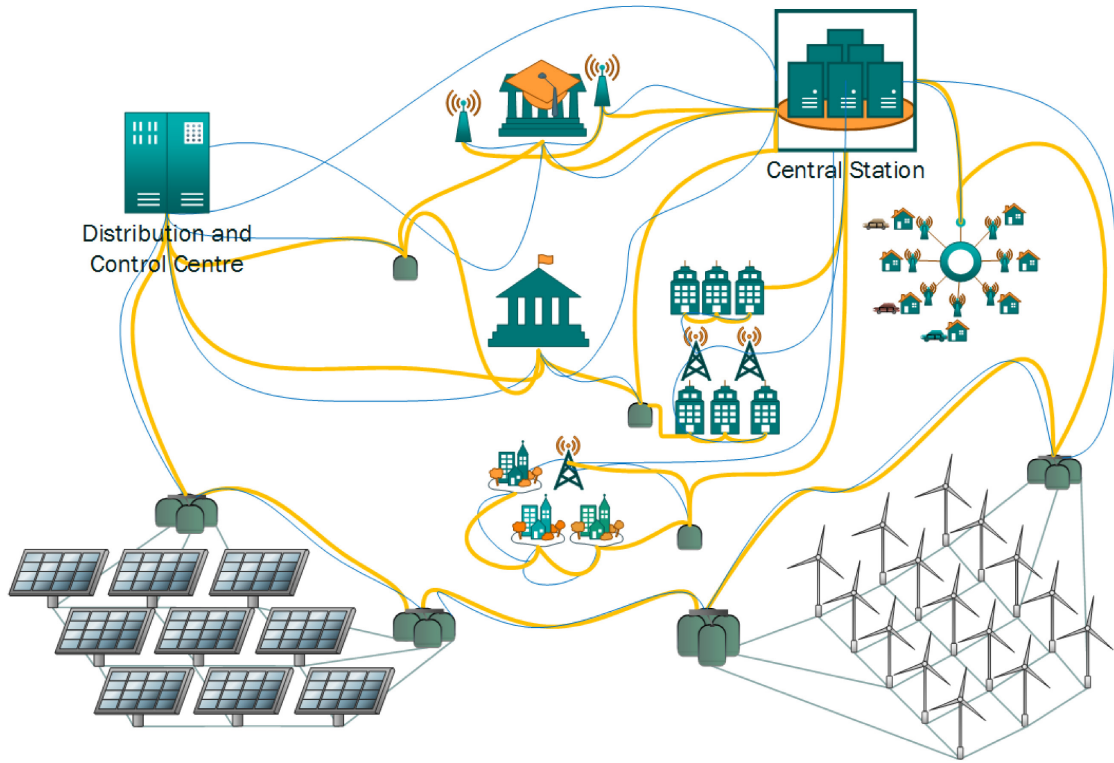

Figure 3-1 - RoF-PON in Smart Grid, yellow shows electric lines, and blue is for data connection

While all the advantages we seek found both in RoF and R&F, we have decided to choose RoF because it requires a significantly simpler infrastructure, and it is more cost effective than R&F. A quick comparison can be seen in Table 3-1. A detailed comparison between the RoF and R&F was conducted in a master’s thesis by our colleague prior to our work [114].

Table 3-1 - Summarized Comparison between RoF and R&F

	RoF	R&F
Complexity	Low	Medium to High

Cost to build	Low	Medium
Cost to operate	Low	Medium
Flexibility	Varies	High
Survivability	Medium to High	Low to Medium

3.2 RoF-PON FOR SMART GRID ACCESS NETWORK

We have established in the last chapter that network architectures and enabling novel technologies for delivering future millimeter-waveband (mm-WB) radio-over-fiber (RoF) system for wireless services with the use of dense wavelength division multiplexing (DWDM) architecture are all desirable features in a Smart Grid access network. We have therefore considered a conceptual illustration of a DWDM RoF system with channel spacing of 12.5 GHz, which was proposed in its first original form by Maamoun and Mouftah in [96]. In the downstream system, the millimeter-wave-band RF signal is obtained at each Optical Network Units (ONUs) by using optical heterodyning photo detection between two optical carriers simultaneously; one optical carrier is modulated with the downloading customer data, while the second is un-modulated carrier. The generated RF modulated signal has a frequency of 12.5 GHz. The reasoning behind choosing this frequency band will be described later in this section. In the upstream system, direct photo detection was used for simplicity. Such a RoF system has simple, cost-effective, maintenance-reduction and is immune to laser phase noise in principle.

In this chapter, a novel millimeter-waveband (mm-WB) radio-over-fiber (RoF) system architecture for wireless services with the use of dense wavelength division multiplexing

(DWDM) of 12.5 GHz channel spacing (according to ITU-T 2002, G.694.1 grid) is proposed. By using Remote Heterodyning Detection (RHD) technique of RoF, the service provider can gain several advantages like low line losses, immunity to lightning strikes/electric discharges. Complexity reduction of the base stations is achieved by attaching light weight Optical-to-Electrical (O/E) converter directly to antenna which is known as Fiber to the Antenna (FTTA). Another advantage of using such a novel system lay in the capability to dynamically allocate capacity based on traffic demands as the RoF systems nowadays are designed to perform added radio-system functionalities besides transportation and mobility. Finally, the proposed RoF-PON system is simple, cost-effective and maintenance-reduction.

The RoF-PON wireless services system that was originally proposed by Maamoun and Mouftah in [96] is illustrated in Figure 3-2. We will illustrate these methods in an RoF-PON system with DWDM using a channel spacing of 12.5 GHz. Our enhancement is illustrated in Figure 3-3. For each downstream signal to an ONU, there are two optical carriers used, one for transmitting data and the other for detection. Our proposed enhancement generates both optical carriers from a single laser source, instead of two phase-locked lasers. Our contribution improved the quality of the signal, while reducing the infrastructure and maintenance requirements of the whole network.

For the proof of concept, an RoF-PON system with one Central Station (CS) and one ONU is verified by simulation. Each optical carrier conveys one Differential Phase-Shift Keying (DPSK) sub-carrier signal over 10 km of an SMF. An electro-optical-modulator (EOM)

at the Remote Antenna Unit (RAU) will generate two optical carriers using the incoming single optical carrier. The electrical signal will be acquired using RHD at the ONU. The Wireless LAN (WLAN) at the base station uses a technology based on IEEE 802.11n which uses Optical Frequency-Division-Multiplexing (OFDM)-based transmission scheme and will work in the 12.5 GHz band. It operates at a maximum physical layer bit rate of 622.08 Mb/s.

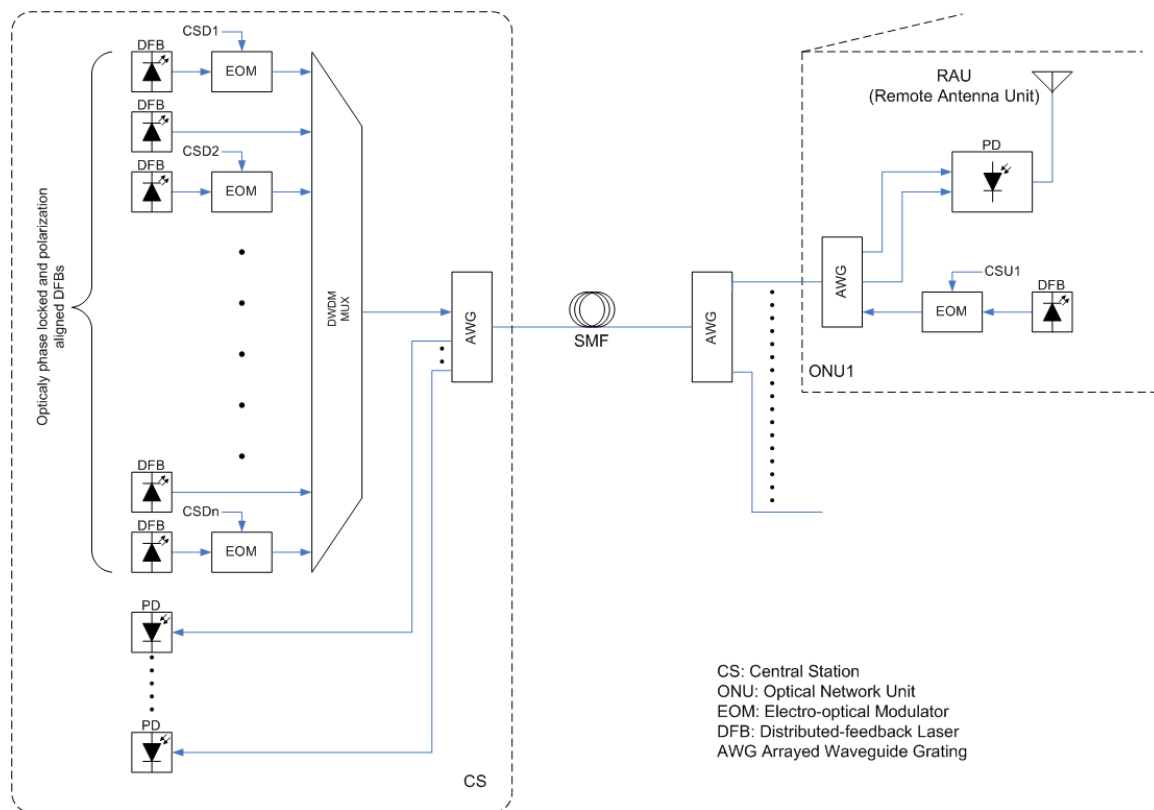

Figure 3-2 – The first RoF-PON model, originally proposed by Maamoun and Mouftah

The CS contains the optical mm-wave source, the data requested by the customers, PDs for receiving customers' uploaded data, a DWDM-MUX, a single DFB Laser which is

externally-modulated using an MZM as an EOM followed by an AWG. On the RAU side, there is a heterodyne PD, a voltages-biased MZM as an EOM, a DFB Laser and an AWG.

In the CS, the optical mm-wave source is created by a single laser and hence it does not need to be phase-locked nor polarization aligned. The laser provides one carrier exiting the CS per RAU. The total number of required wavelengths for N ONUs is N only. We kept the channel spacing as 12.5 GHz.

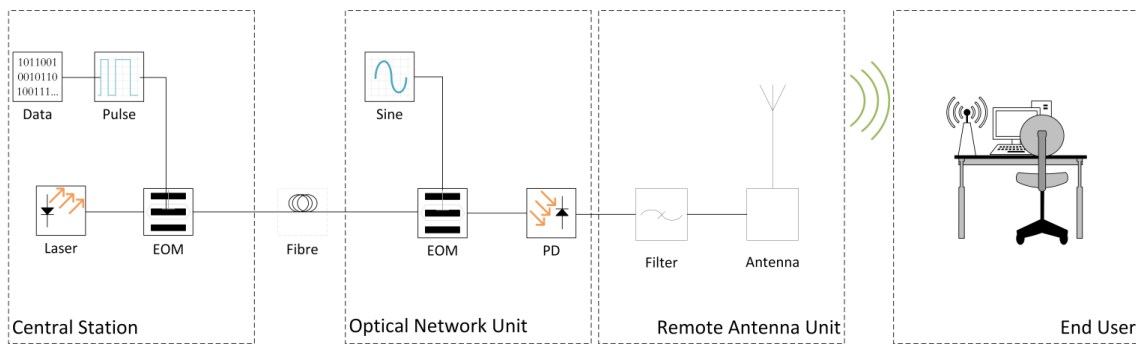

Figure 3-3 - The Novel Enhancement to the RoF-PON

In reception, Each RAU uses the received optical signal to generate two optical carriers using a MZM as an EOM, separated by 2ω Hz and centered at the original optical carrier, which is suppressed due to the MZM. Then the RF signal is obtained at each ONU by using RHD PD between two optical carriers simultaneously. The generated RF modulated signal has a frequency of 12.5 GHz. The resulting RF signal is then amplified and transmitted directly by the antennae, using an Optical to Electrical (O/E) converter. For the uplink system, we used direct photo detection, because it's the simplest form.

The reduction of the number of lasers in the system from $2N-1$ to N , does not only reduce the cost of the system, but also the complexity; for the proposed enhancement does not require phase-locking or verifying that the polarizations of the two carriers per ONU are aligned together. Additionally, the significant reduction of the laser power through the fibre adds to the robustness, since optical fibres containing high levels of power begin to show non-linear characteristics, which are very undesirable in any telecommunication system [115].

3.2.1 Mach-Zehnder Modulation

There are three common link types in RoF: using a Directly Modulated Laser (DML), an external modulation of wireless signal onto the laser using a Mach-Zehnder Modulator (MZM) or a Reflective Semiconductor Optical Amplifier (RSOA) [99]. An experimental study [100] found that MZM has a superior advantage over the other two link types in simplicity and cost effectiveness. While it lags a little behind in performance, all three exceed the range and gain requirements for a Neighbourhood Area Network (NAN) and Metropolitan Area Network (MAN) in our research, as shown in Table 3-2. Therefore, we decided to carry our research using the MZM.

Table 3-2 - Comparison of Different RoF Link Types

	DML	MZM	RSOA
Complexity	Medium	Low	High
Cost	High	Low	Medium
Receiver Gain/Loss (dB)	-28	-42	-42

Max Input Power Loss (dBm)	-2	-3	+2
Amplifier Gain (dB)	47	46	51
Noise Figure (dB)	5.5	7.6	6.4
Radio Range (m)	460	360	410

When mixing two optical signals coherently at a photodiode, two electric signals are generated. The two signals are generated at the sum as well as the difference frequencies of the two optical signals. This method is often implemented with two phase-locking lasers such that the difference between their respective frequencies would be the desired mm-wave electrical signal [116], [117] and [118].

On the other hand, using a single laser source with an MZM as an EOM, the same result can be obtained. The single drive MZM has to be biased using a sinusoidal modulated voltage which is governed by the equation

$$v(t) = V_{\pi}(1 + \varepsilon) + \alpha V_{\pi} \cos(\omega t) \quad (3-1)$$

where ε is the normalized bias point of the modulator, α is the normalized amplitude of the voltage and ω is the frequency of the voltage drive. The output of the modulator can be described by

$$E(t) = \cos\left\{\frac{\pi}{2} [(1 + \varepsilon) + \alpha \cos(\omega t)]\right\} \cos(2\pi v_o t) \quad (3-2)$$

where v_o is the optical carrier frequency.

Performing a Bessel function expansion leads to the expression

$$\begin{aligned}
E(t) = & \frac{1}{2}J_0\left(\frac{\pi}{2}\alpha\right)\cos\left[\frac{\pi}{2}(1+\varepsilon)\right]\cos(2\pi v_o t) \\
& - J_1\left(\frac{\pi}{2}\alpha\right)\sin\left[\frac{\pi}{2}(1+\varepsilon)\right]\cos(2\pi v_o t \pm \omega t) \\
& - J_2\left(\frac{\pi}{2}\alpha\right)\cos\left[\frac{\pi}{2}(1+\varepsilon)\right]\cos(2\pi v_o t \pm 2\omega t) \\
& + J_3\left(\frac{\pi}{2}\alpha\right)\sin\left[\frac{\pi}{2}(1+\varepsilon)\right]\cos(2\pi v_o t \pm 3\omega t) \\
& + \dots
\end{aligned} \tag{3-3}$$

When the voltage $V_\pi(\varepsilon = 0)$ is applied, the signal at v_o will be suppressed, as well as all the even terms in the expansion. The only strong term which remains is the one with two components separated by 2ω and centered around v_o . Good biasing techniques can easily mute the other components to 15dB below the main components [119]. When these two optical components are mixed on a photodiode, an electrical signal is obtained with frequency 2ω .

3.2.2 Remote Heterodyne Detection

Most RoF techniques rely on the principle of coherent mixing in the photodiode. These techniques are generally referred to as Remote Heterodyning Detection (RHD) techniques. While performing O/E conversion, the photodiode also acts as a mixer thereby making it a key component in RHD based RoF systems. However, this does not necessarily make it the most complex or expensive component in the entire system. Since most methods utilize coherent mixing, the principle is discussed first.

Two optical fields of angular frequencies ω_1 and ω_2 can be represented as:

$$\begin{aligned}
E_1 &= E_{01}\cos(\omega_1 t) \\
E_2 &= E_{02}\cos(\omega_2 t)
\end{aligned} \tag{3-4}$$

If both fields impinge on a PIN photo detector, the resulting photocurrent on the surface will be proportional to the square of the sum of the optical fields. That is the normalized photocurrent will be:

$$i_{PIN} = (E_1 + E_2)^2 = E_{01}E_{02} \cos(\omega_1 - \omega_2)t + E_{01}E_{02} \cos(\omega_1 + \omega_2)t + \text{other terms} \quad (3-5)$$

The term of interest is $E_{01}E_{02} \cos(\omega_1 - \omega_2)t$ which shows that by controlling the difference in frequency between the two optical fields, radio signals of any frequency can be generated. The only limit to the level of frequencies that can be generated by this method is the bandwidth limitation of the photodiode itself [10]. Let us consider optical power signals instead of optical fields, then the generated photocurrent is given by:

$$i_{PIN} = 2R\sqrt{p_1(t)p_2(t)} \cos[(\omega_1(t) - \omega_2(t))t + \phi_1(t) - \phi_2(t)] + \text{other terms} \quad (3-6)$$

Where R is the responsivity of the photo detector, t is the time, $p_1(t)$ and $p_2(t)$ are the two instantaneous optical power signals with instantaneous frequencies, $\omega_1(t)$ and $\omega_2(t)$ respectively. The instantaneous phases of the signals are given by $\phi_1(t)$ and $\phi_2(t)$ respectively.

Two laser diodes are made to emit light at frequencies (wavelengths) separated by the required microwave frequency. The two electric fields will then mix on the photodiode to yield an electrical signal as described above. However, since the relative offset between the two optical carriers is so small compared to the absolute frequencies of the carriers, any small frequency drift in either of the carriers translates into a major shift in the generated microwave frequency. This implies that, to keep a stable microwave signal at the output of the photodiode the relative offset between the emission frequencies must be

kept constant. In other words, absolute shifts in emission frequencies are not important, but the relative offset only. Normally, only one of the two optical carriers is modulated with data.

Given that the laser emission frequency is highly sensitive to temperature variations, phase noise and other effects, techniques to maintain the required frequency offset have to be used. There are several methods for controlling the relative frequency offset between the two lasers.

3.2.3 The Ku Band for Wireless Data Communication

Wi-Fi was created with the aim of use within unlicensed spectrum. There are a number of unlicensed spectrum bands in a variety of areas of the radio spectrum that are referred to as ISM bands (Industrial, Scientific and Medical). Most commonly known Wi-Fi bands are 900 MHz (802.11ah), 2.4 GHz (802.11b/g/n), 3.6 GHz (802.11y), 4.9 GHz (802.11y), 5 GHz (802.11a/h/j/n/ac), 5.9 GHz (802.11p) and 60 GHz (802.11ad). There is an interest of using frequencies between 5.9GHz and 60 GHz.

The Ku-band is the wireless frequency band commonly known to have been used for radar applications. It ranges at 12-18 GHz band and it is primarily used for satellite communications. There are other ITU allocations have been made within the Ku-band for different applications. In the recent years, many military and radar application that used to occupy the Ku band have relocated to different bands, creating many unlicensed gaps within this band.

The targeted 12.5 GHz of the proposed system design, that is located inside the desired Ku-band, provides the additional desired bandwidth. Being at a higher frequency, equipment costs are not very much higher, although usage - and hence interference – is significantly less. It is obviously realized that this frequency band will be a candidate for a future protocol of IEEE 802.11.

3.3 RoF PON FOR NEIGHBOURHOOD AREA NETWORK

3.3.1 Ring RoF-PON

The most challenging issue in a Ring RoF PON is moving the signal optically from one node to another in a passive environment. We made sure all nodes are colourless (i.e. wavelength independent) to increase security and reliability of the network. Hence, we used the same optical signal at all ONUs, while shifting the frequency at the signal before it leaves each node using an all-optical wavelength converter.

3.3.1.1 All-Optical Wavelength Conversion

For decades, numerous works have studied optical frequency conversion techniques. The most commonly known methods today are Cross Gain Modulation (XGM), Cross Phase Modulation (XPM), and Four Wave Mixing (FWM). [120], [121], [122], [123]. The problem with the first two is that they are wavelength sensitive, hence they will require a different converter for every single wavelength. This is very inconvenient. As for four wave mixing, it is wavelength independent. However, it has a drifting error which is too significant for our

criteria. The research in this area still needs more work, hence we used a typical simulation frequency converter as will show in Chapter 4.

3.3.2 RoF-PON and the Internet of Things

With the implementation of RoF for the Smart Grid, it will be an existing infrastructure that can be reused for other technologies. To demonstrate this, we propose the following scenario. Smart meters need a secure, reliable two-way communication with the control centre. Users who have broadband internet at home already enjoy a secure reliable two-way communication with the internet. However, the thought of sharing bandwidth is unpleasant to many customers. Smart meters require very small bandwidth that is insignificant to any internet bandwidth, the case is similar to most IoT platforms as they communicate with control signals.

0	3	7	15	23	31		
Ver 4		IHL		ToS		Total Length	
Identification				Flags	Fragment Offset		
TTL		Protocol		Header Checksum			
Source Address (32 bits)							
Destination Address (32 bits)							
Options					Padding		

(a)

0	3	7	15	23	31		
Ver	IHL		ToS		Total Length		
Identification				Flags	Fragment Offset		
TTL		Protocol		Header Checksum			
Source Address (32 bits)							
Destination Address (32 bits)							
Options						Padding	

(b)

Figure 3-4 - Example of IoT Header in (a) typical IPv4 header showing (b) Smart Meter Flag

Therefore, we propose the following incentive to customers. A header extension to the IP protocol is introduced, which carries one flag bit – we will call it a Smart Meter flag for this example. As header extensions in IPv4 and IPv6 are unencrypted by default, the ISP will be able to determine which packets were requested by the customer and those requested by the smart meter directly. The ISP bills the customer directly for the entire usage, while sharing the total usage of the Smart Meter with the utility, the utility then, verifies the smart meter with their records, and sends a refund to the customer for the amount of Smart meter usage through their internet connection. Despite the usage – and hence the refund - being insignificant, the scheme is appealing, sustainable, and saves the utility from expanding onto infrastructure of their own. The same method can be applied with the RoF-PON in the smart grid, sharing it with any local IoT network available at that home. The resulting infrastructure will eventually converge to what we expect to be named the Internet of Everything (IoET).

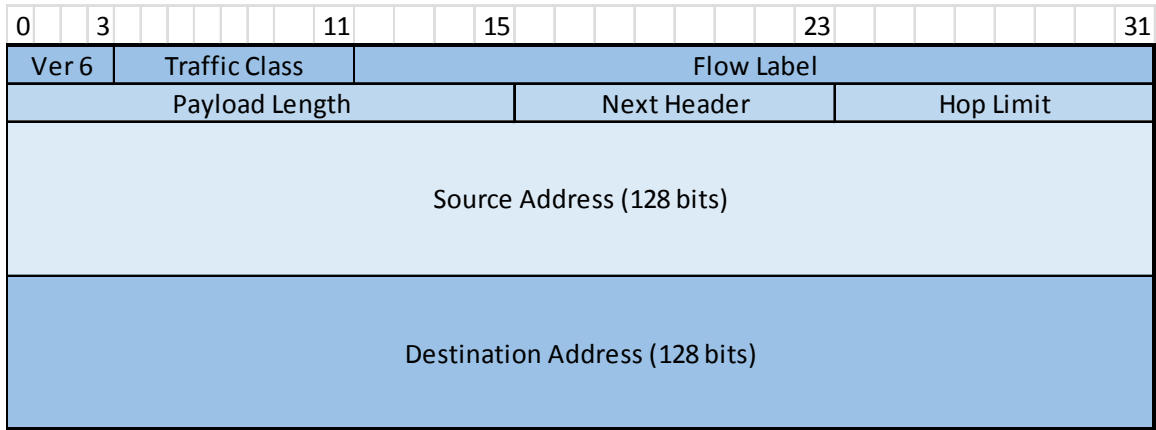

(a)

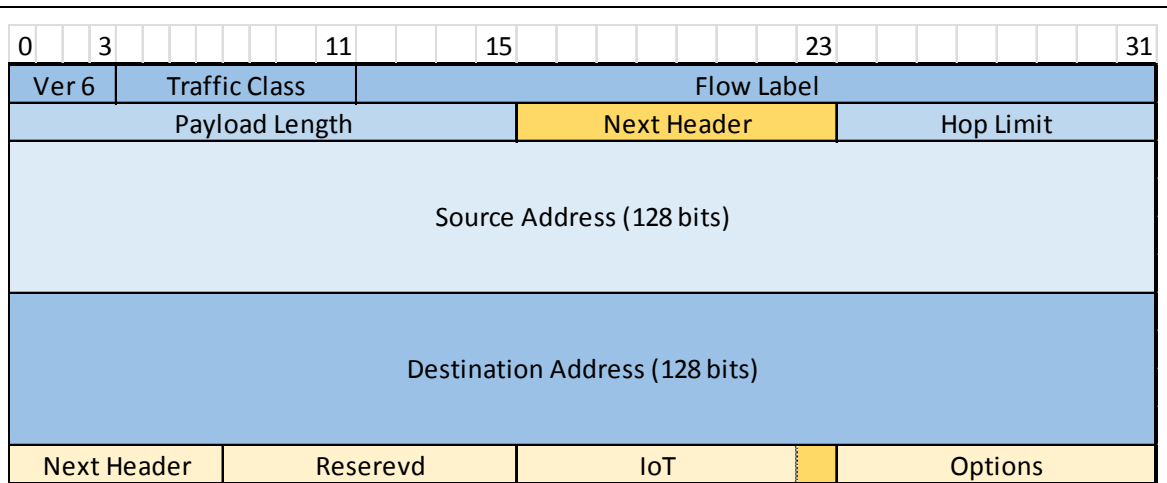

(b)

Figure 3-5 - Example of IoT Header in a typical (a) IPv6 header showing (b) smart meter flag

3.3.3 Survivability

Survivability is a crucial element in network planning to ensure continued availability of service in normal as well as emergency situations. According to ITU-T G.983.1 [124], there are four PON protection schemes which are:

1. Feeder Fibre Protection
2. OLT & Feeder Fibre Protection
3. Full Duplication

4. Independent Duplication

Survivability models particularly for RoF-PON were discussed by Maamoun and Mouftah [97]. However, the case of ring RoF-PON was not discussed. Our work was built on the foundations of wireless restoration or Wireless Mesh Network (WMN)-Based Fi-Wi Architecture, discussed in [125].

We have firstly considered the following case showing a Ring RoF-PON network with N number of nodes and N number of links. In the first model, it takes one failure in link or node M , to immediately disconnect that node from the network. Adding a survivability model through the wireless part, the data in link or node M can be rerouted from node $(M-1)$, through the radio network, as long as the wireless receivers of M ONUs are within the range of the $M-1$ ONU, which is the case for most NAN access networks.

The second case will be the failure of the wireless reception circuit at the ONU of the node itself, this will also be rerouted through the wireless coming from the next-door ONU, as demonstrated in the graphs below.

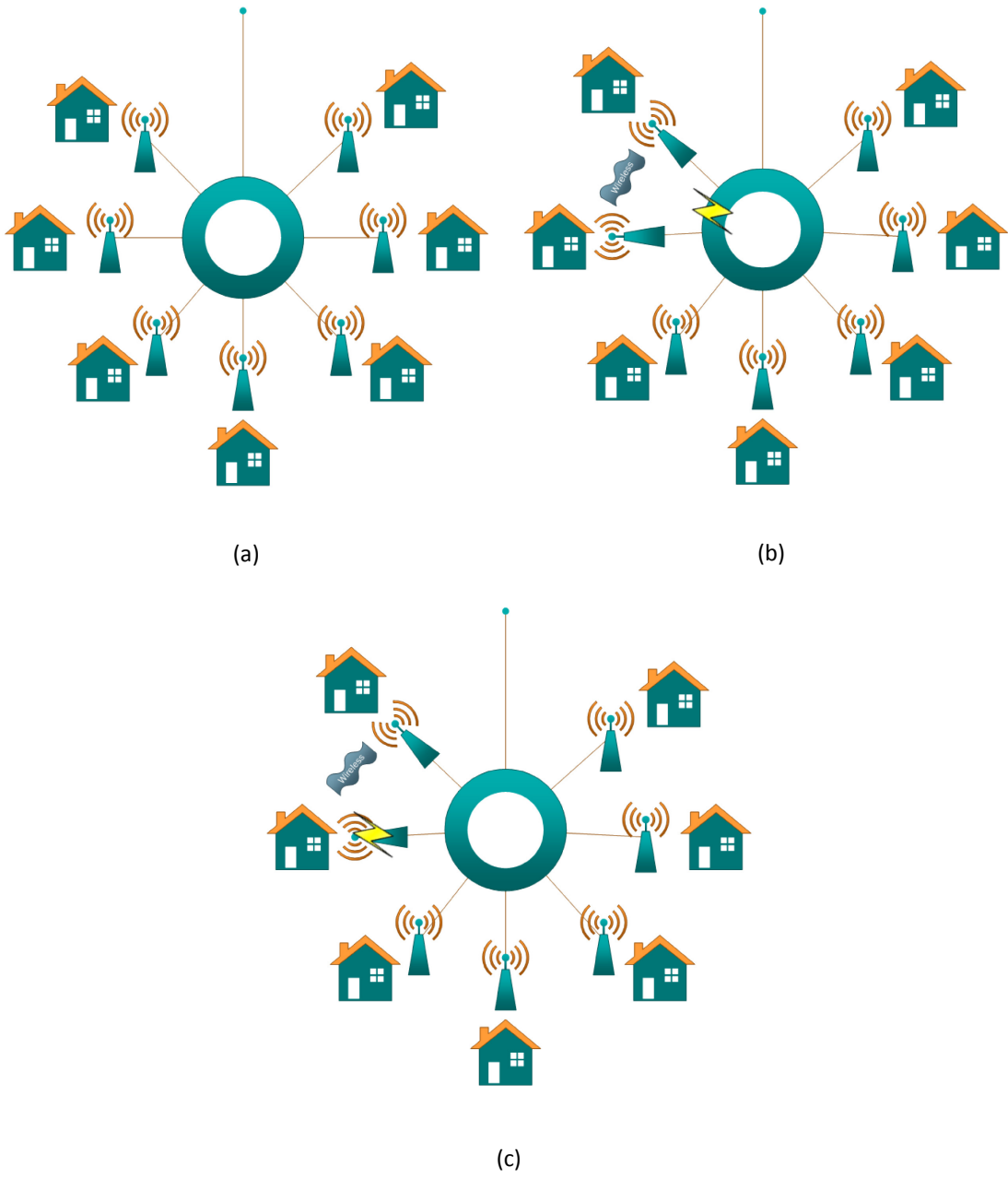

Figure 3-6 - Survivability model for (a) Ring-RoF-PON in the event of (b) fibre link failure (c) RAU node failure

The maximum data throughput will not be affected at all since all nodes receive the signal wirelessly. However a small delay will be introduced due to the wireless network delay being greater than that of the optical link. Since the scale of the ring is usually within

that of a Neighbourhood Area Network (NAN), then the difference in delay will be insignificant and will not lead to any time-out delays or MAC layer errors, as per the equation:

$$\text{Packet Transmission Delay} = D_{Proc} + D_Q + D_T + D_{Prop} \quad (3-7)$$

Where D_{Proc} is processing delay, D_T transmission delay (unchanged), D_{Prop} is propagation delay (unchanged) and D_Q is the queuing delay. Only the first and last one will be affected by this change, and since

$$D_{Proc} \ll D_Q \quad (3-8)$$

Then only D_Q will be changed, however the change will be orders of magnitude less with respect to the smart grid neighbourhood area network requirements. Hence there will not be a significant negative impact to the network.

3.4 SUMMARY

In this chapter we have investigated RoF-PON as an infrastructure in detail that can be implemented using different wireless protocols such as Wi-Fi, LTE, etc. The front-end technology can be implemented at the smart homes, smart farms, substations, etc for the purpose of smart metering and controlling operations and resources in the smart grid. In Section 3.2, we have described in detail our system model based on the RoF-PON network. In Section 3.3, we described our topology for NAN. Finally, we have developed an IoT integration scheme, and a survivability model.

Chapter 4. SIMULATION AND PERFORMANCE RESULTS

4.1 INTRODUCTION

In this chapter, we evaluate the performance of the adopted RoF-PON architecture under the WDM enabling technology system model presented in Section 3.2. We use the simulation environment, which is developed locally in Ottawa by Optiwave. Section 4.2 continues with a description of the simulation settings and assumptions. Section 4.3 presents the simulation results under different topologies, along with their analysis. Finally, Section 4.4 provides a summary for this chapter.

4.2 SIMULATION SETTINGS AND ASSUMPTIONS

The system we have simulated is shown in Figure 4-1, with details in Figure 4-2 and Figure 4-3. Creating subsystems helps make the simulation modular and easier to organize.

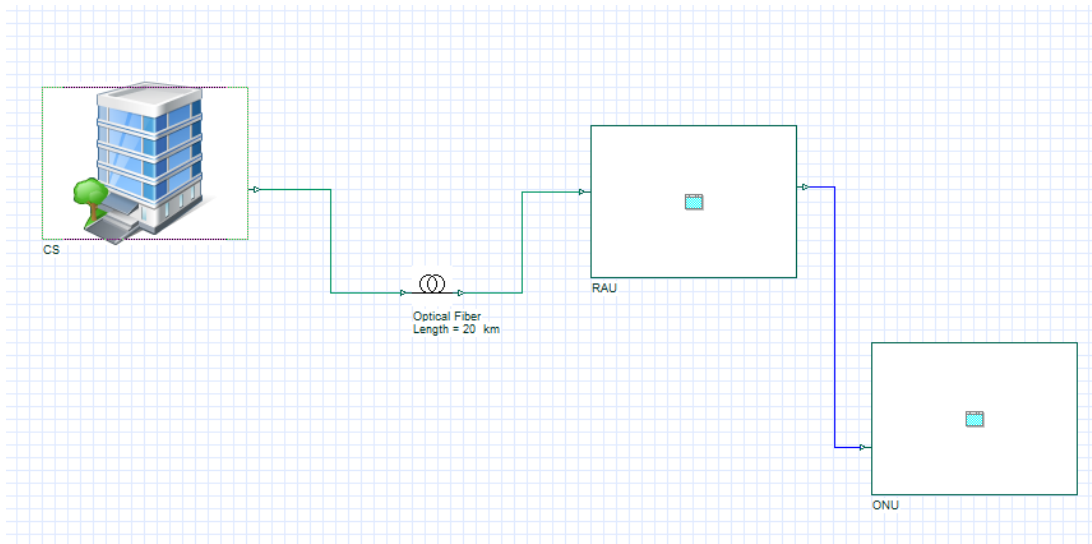

Figure 4-1 - RoF-PON System Simulation with one node

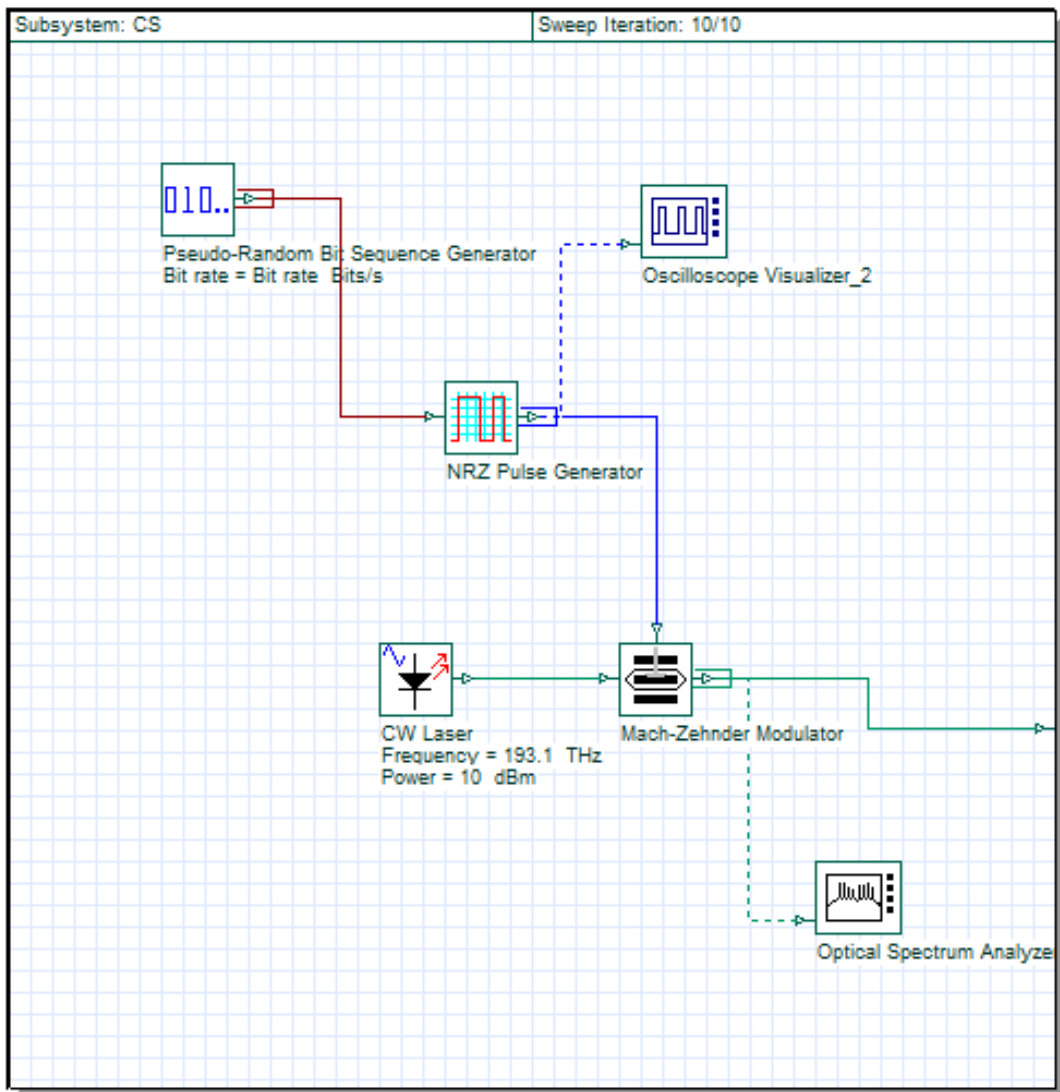
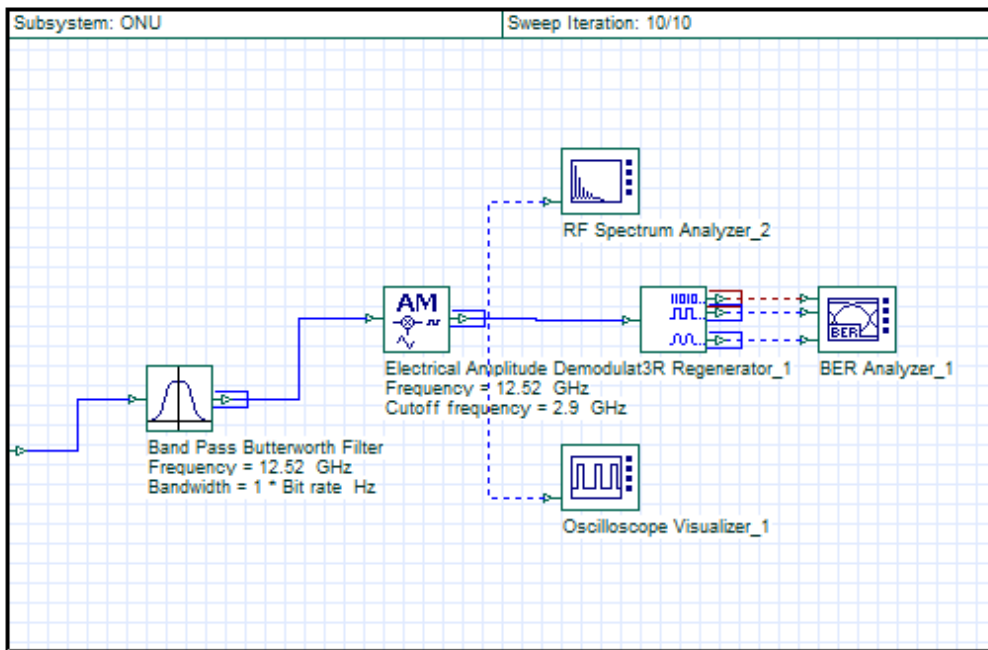
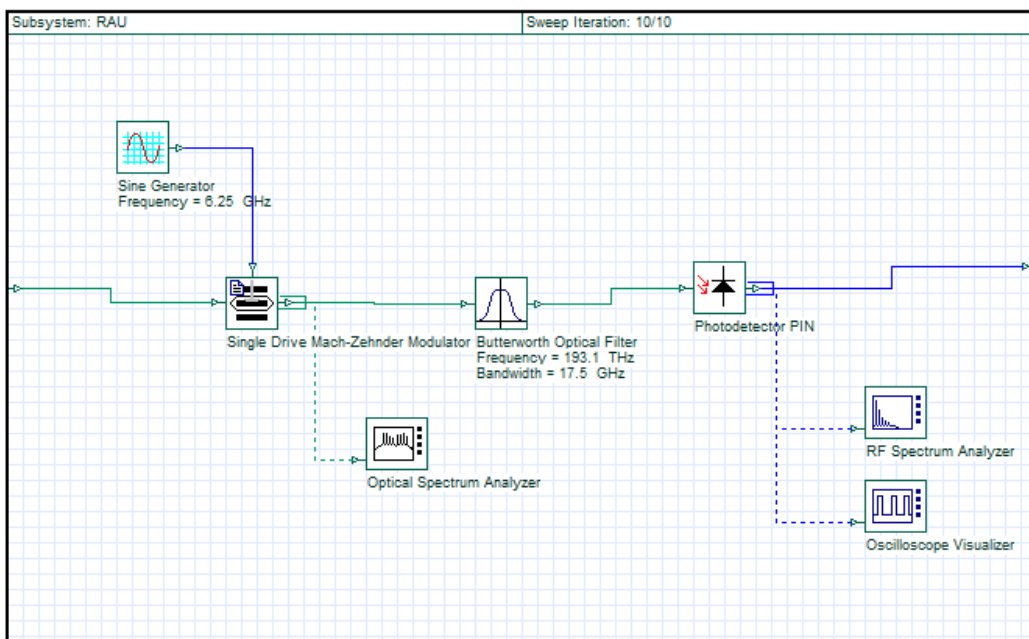

Figure 4-2 - Inside the CS



(a)



(b)

Figure 4-3 - (a) inside the RAU and (b) inside the ONU

The following parameters were used in this simulation, and were based on the standard optical parameters per the simulation manual.

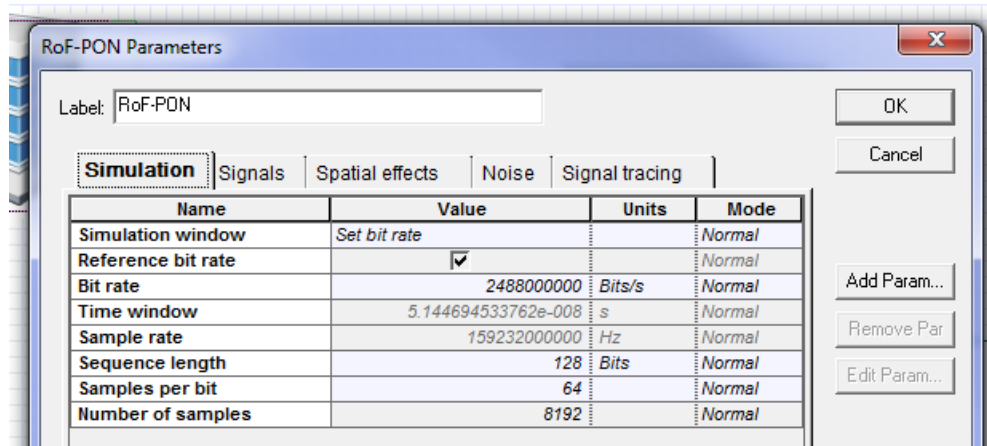

Figure 4-4 - RoF-PON Simulation parameters

For the NAN, we have built the following Ring-RoF-PON system.

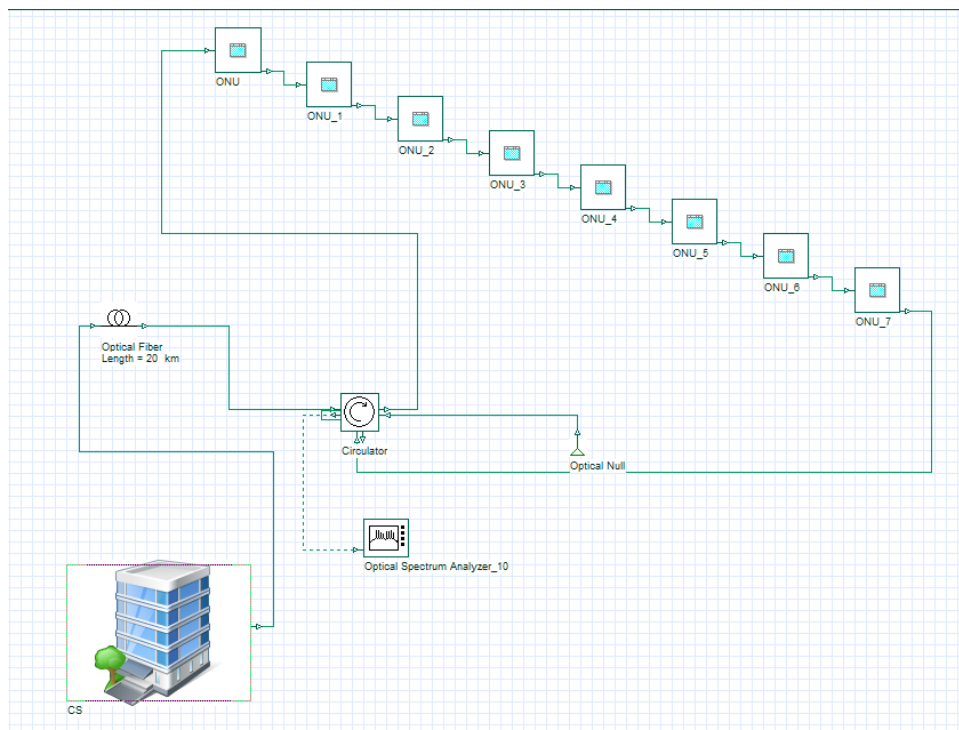

Figure 4-5 - Ring ROF-PON for NAN

The CS is the same as in Figure 4-2. As for the each ONU on the ring, it is built as the following Figure 4-6.

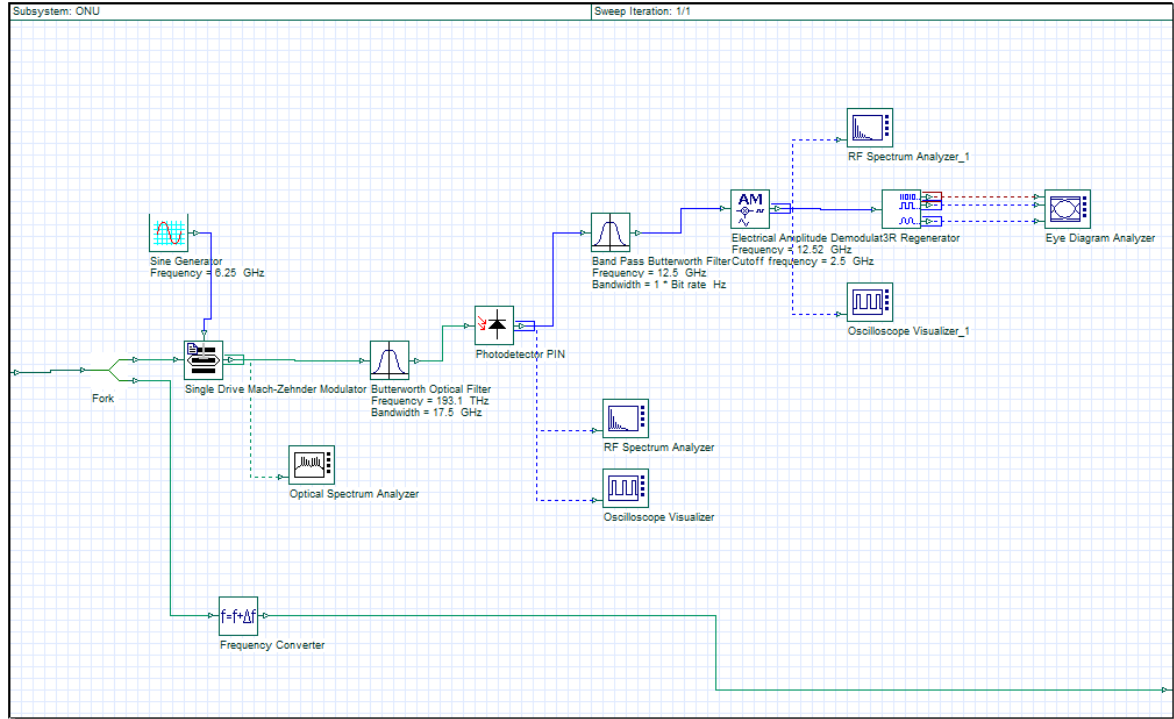

Figure 4-6 - ONU of a Ring-RoF-PON

4.3 PERFORMANCE RESULTS

The downlink configuration is simulated in the same way, with a CS and one ONU. One optical carrier with wavelength of 1552.52438115 nm is used in the simulation.

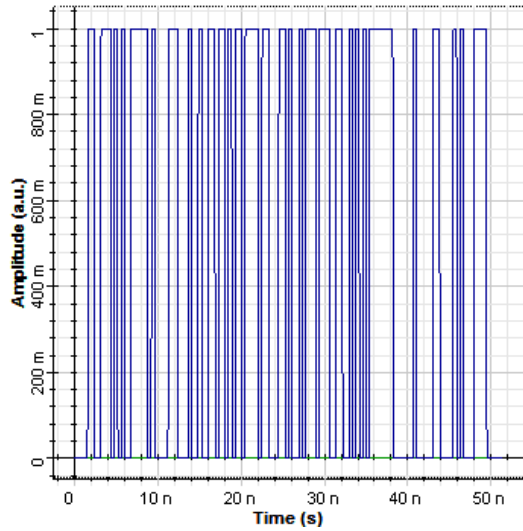

Figure 4-7 - Pseudo-Randomly Generated Data

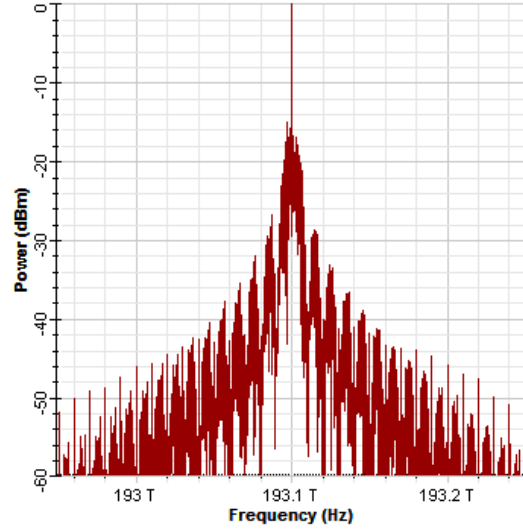

Figure 4-8 - The Modulated Optical Carrier at CS

The transmission circuit at the CS is comprised of incoming data (Figure 4-7) a single laser source per RAU (Figure 4-8), an EOM driven by a DPSK modulated signal at 622.08 Mb/s. The MUX combines all optical carriers for all RAUs before transmission via optical fibre. The signal travels across 20 km of SMF before arriving at the RAU. A de-multiplexer is used followed by a voltage-biased EOM, which creates two carriers centered around ν_o and separated by 2ω , while suppressing the original carrier, as seen in Figure 4-9.

The optical signal is then passed on to photo-detection. The generated RF current (Figure 4-10) is then filtered to a signal with 12.5 GHz bandwidth, as seen in Figure 4-11. The user receives the wireless data transmitted by the RAU and recovers the data after DPSK demodulation.

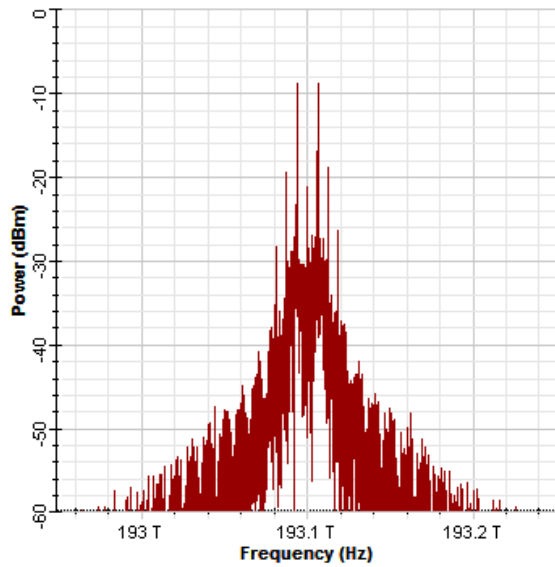

Figure 4-9 - The Shifted Optical Carrier at ONU

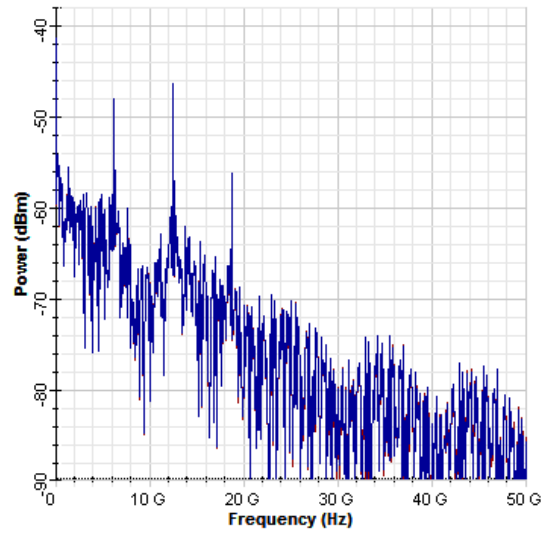

Figure 4-10 - RF Current Generated by the Photodetector at the ONU

Using a simple modulation scheme, the data is sent wirelessly from the ONU, where the receiving device at the user would filter and de-modulate the transmitted data. The eye diagram of the received signal at the user can be seen in Figure 4-12.

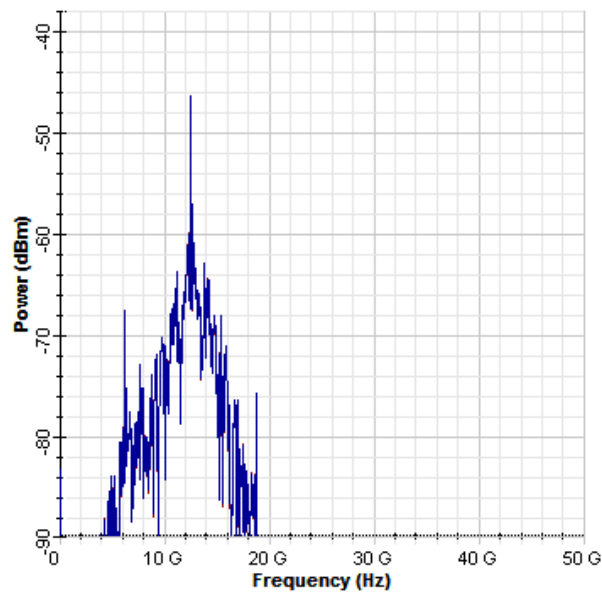

Figure 4-11 - The RF Signal Filtered Around 12.5 GHz

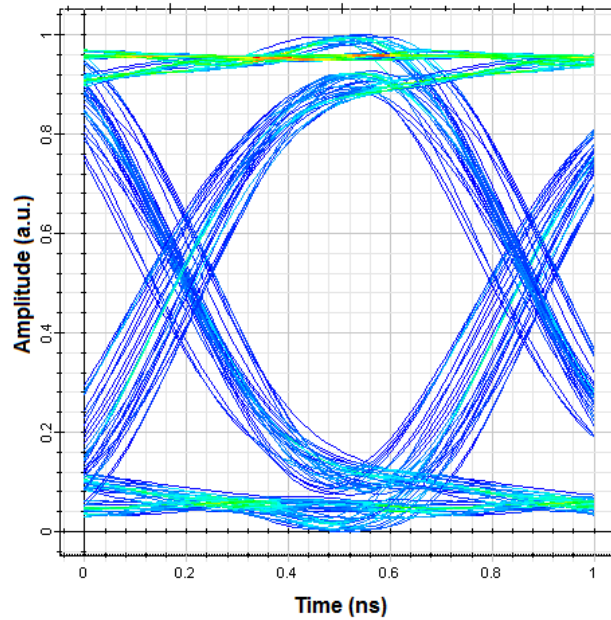
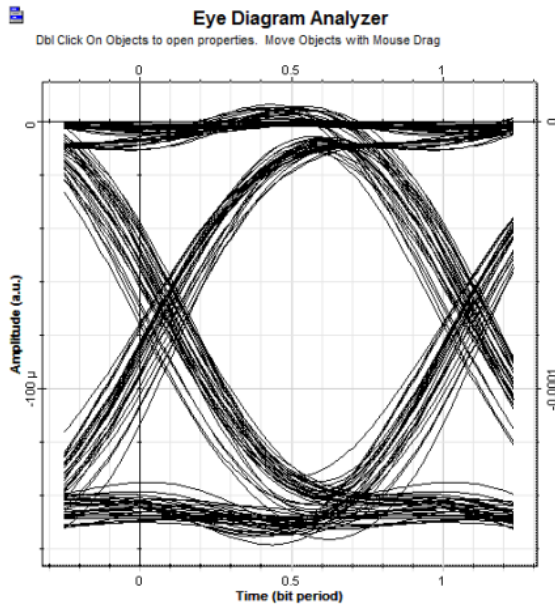
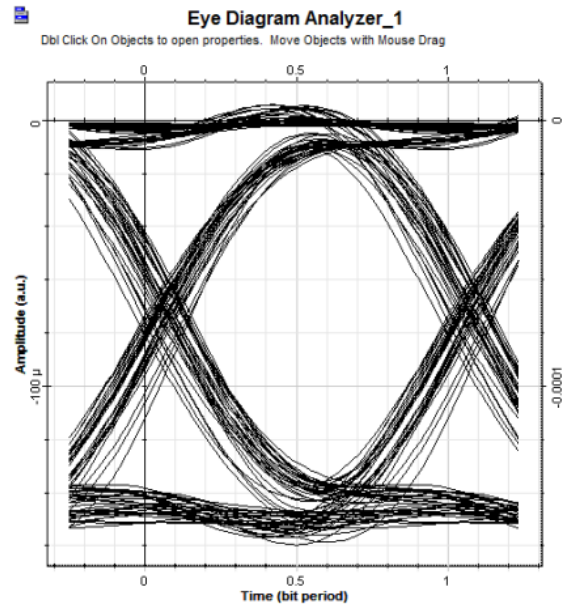

Figure 4-12 - The eye diagram of the received data at the RAU

The simulation of the Ring-RoF-PON is similarly successful. We assumed a Ring RoF-PON with 8 nodes connected using a unidirectional ring fibre. In the beginning we were not able to obtain any signal in simulation. After exhausting all research and troubleshooting the issue, we contacted the simulation technical support and found that due to initialization issues, the simulator would not operate smoothly in ring until after many loops. We carried the simulation then with 20 optical iterations in the ring. After nearly 17 loops, we were able to obtain the steady state signal in all ONUs of the ring. Figure 4-13 and Figure 4-14 show the final steady states eye diagrams in all ONUs of the ring network at the simulated smart home NAN.



(a) Eye Diagram of First ONU Node



(b) Eye Diagram of Second ONU Node

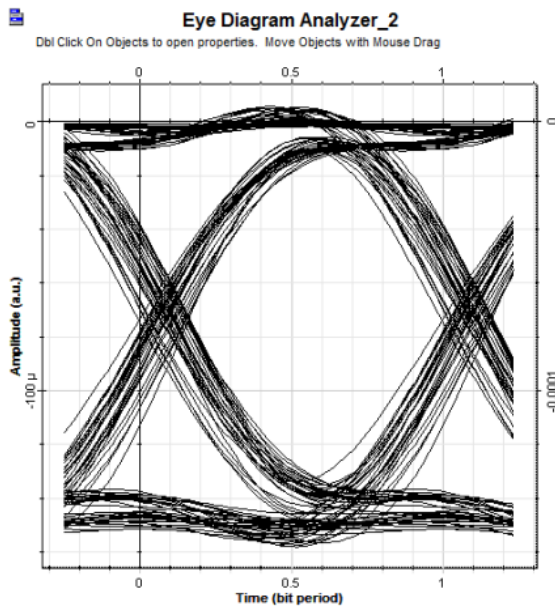

(c) Eye Diagram of Third ONU Node

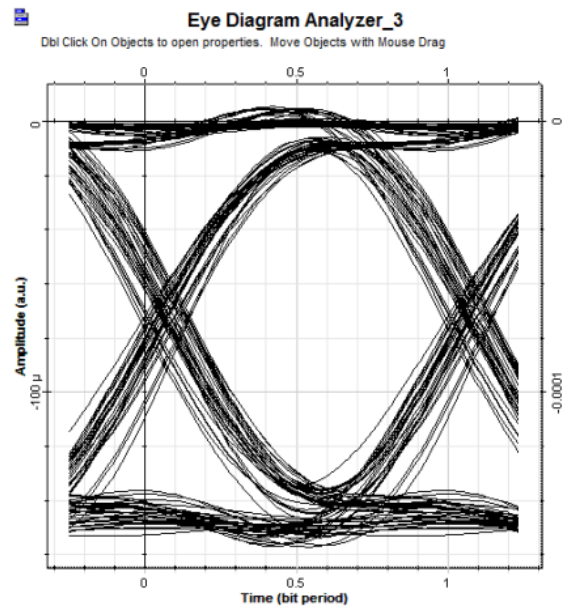

(d) Eye Diagram of Fourth ONU Node

Figure 4-13 - The eye diagrams in the first half of nodes on the ring RoF-PON network

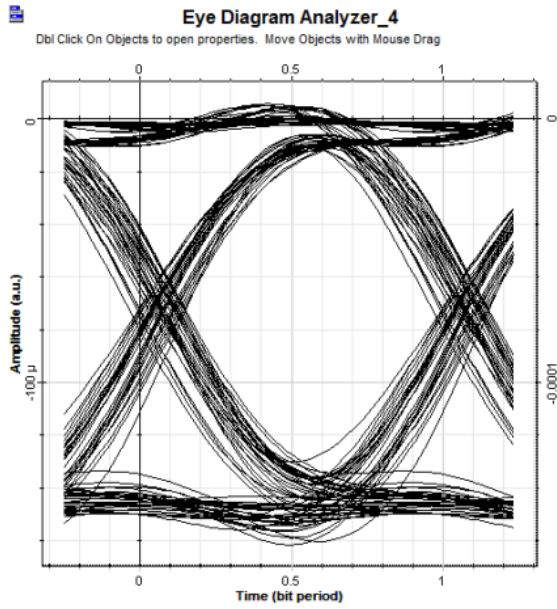

(a) Eye Diagram of Fifth ONU Node

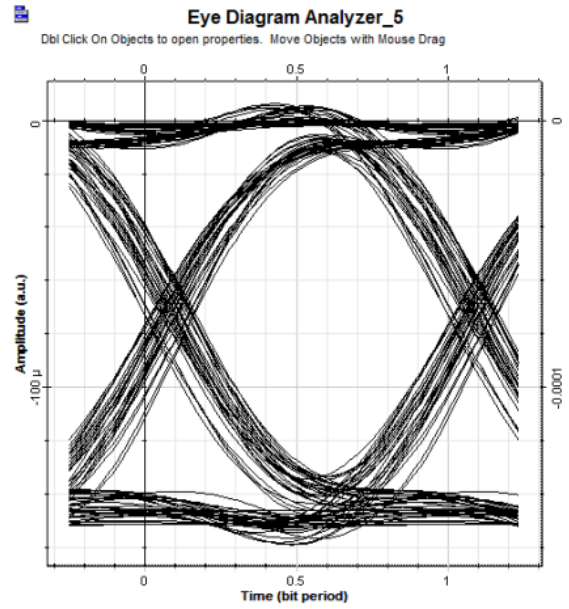

(b) Eye Diagram of Sixth ONU Node

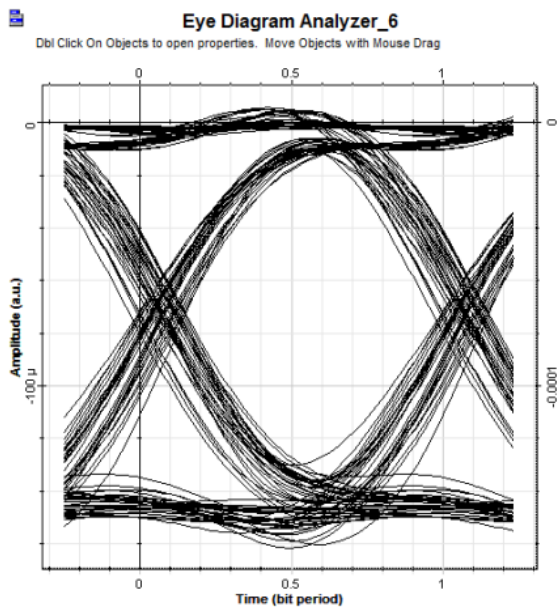

(c) Eye Diagram of Seventh ONU Node

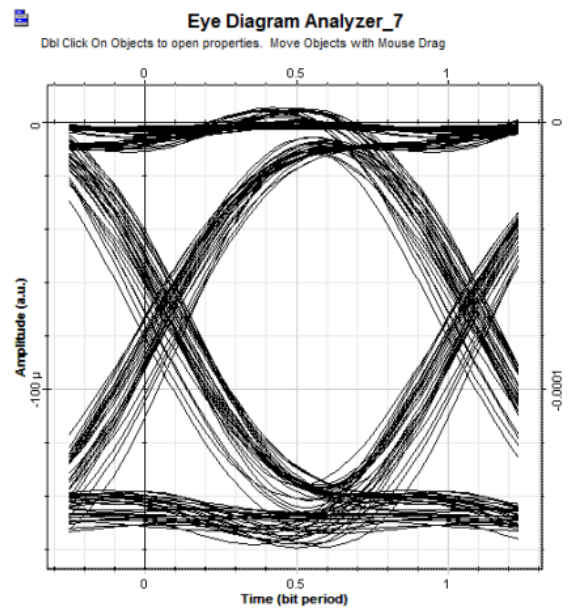

(d) Eye Diagram of Eighth ONU Node

Figure 4-14 - The eye diagrams of the second half of nodes on the ring RoF-PON network

4.4 SUMMARY

In this chapter we have presented simulation settings and assumptions for the performance evaluation of the adopted broadband access network architecture under the proposed RoF-PON infrastructure. We have considered various topologies as well as different related values for each topology. Finally, we have analyzed the simulation results and we have identified the most suitable parameters of the RoF-PON in backbone access network level as well as on neighbourhood area network level.

Chapter 5. CONCLUSION AND FUTURE WORK

5.1 CONCLUDING REMARKS

This thesis has focused on the communication system for the smart grid application by adopting a two-way, secure, fast and flexible communication infrastructure with ICT capabilities. For this purpose, we have first considered the conventional power grid structure and explored the potential importance of introducing the smart grid technology, in order to provide a long-term future proof grid, create a platform for compatible standardization, enable the IoT, become independent of fossil fuel shortage crisis and significantly decrease global GHG emissions. We have found that the smart grid data communication infrastructure is an essential platform for increasing performance, features and reliability of the power grid. According to the aforementioned features for the power grid, we have reviewed Fi-Wi technologies and their advantages and weaknesses as separate communication network infrastructures for smart grid applications. To exploit the strength of each of the wireless and optical network technology, we investigated Fi-Wi integrated networks for the Smart Grid access network. Considering all the factors we have discussed, we concluded that the Fi-Wi infrastructure provides significant promises for the communication infrastructure in the smart grid application.

We have discussed Fi-Wi enabling technologies and decided to adopt the RoF-PON architecture with WDM-PON as the backhaul access network integrated to the front-end wireless access network based on the mmW wireless communication bandwidth, aimed to provide an integrated broadband access network. Consequently, we have proposed a RoF-PON

infrastructure for implementing WDM-PON technology as the shared medium for both smart metering and FTTX traffic, besides using the wireless access network as a low cost implementation technology at the premises. In addition, we discussed the advantages and challenges, as well as summarized the state of the art, for RoF network architectures from recent publications.

Next, we have classified the networks by upper level access network, and local level neighbourhood access network, as requiring different topologies, based on the utilization and requirements of the network. Then we adopted a tree topology for the main access network and a ring topology for the NAN, which would help aggregate data securely from smart meters as well as embedded sensors in smart appliances, power generators and critical equipment in the smart grid.

The main focus of this thesis was to introduce the RoF-PON architecture to the Smart Grid. We have considered that the infrastructure will not only enable the Smart Grid access communication, but can also be used as the access network for many other services, like the Internet access network, as well as any other IoT access network. To further make this more appealing, we have proposed a novel billing method that would save customers from any charges of using their internet bandwidth for IoT communication (such as smart meter forecasting and aggregation, or any other smart appliances).

Finally, we have chosen a simulation environment and assigned the settings and assumptions for performance analysis of the applied RoF-PON infrastructure. The simulation environment covered the entire adopted broadband access network. Our simulation results, based on varying parameters, have shown that RoF-PON, both in the tree and the ring

topologies, meet and exceed the requirements for smart grid including performance and reliability.

We have introduced a survivability model at the NAN level, to further strengthen the reliability of the network.

According to the simulation results, the overall conclusion is that RoF-PON is a transparent, future proof infrastructure that is compatible with any virtually wireless protocol, and has capacity for any wireless bandwidth.

5.2 FUTURE RESEARCH

Fi-Wi networks are a promising solution for future broadband access networks. Their combination of wider bandwidth in the optical network and mobility and flexibility of wireless technology has been actively studied.

Despite the recent advancements at the Fi-Wi physical layer, we still witness related issues at the physical level, such as developing a reliable, wavelength-independent all-optical frequency converter.

The design of energy efficient network infrastructures is of interest to providers for the future of green network technologies that enable the IoT. For this purpose, an IoT extension header protocol should be defined as a point of future work for enabling IoT utilization of the access network. It is also important to focus on the Green Broadband Access Network Technology (GBANT) to provide energy efficient solutions for this type of integrated telecommunication network.

Another interesting topic in the PHY layer to be developed in the future is to consider the R&F technology for this form of broadband hybrid networks. For instance, the major limitation of the WLAN-based R&F technology is that it becomes a bottleneck for data processing and that degrades the reliability aspect. Furthermore, the additional propagation delays caused by distributed MAC protocols limit the optical fiber range and also degrade the integrated network performance.

REFERENCES

- [1] United States Environmental Protection Agency, "Global Greenhouse Gas Emissions Data," EPA, 9 September 2013. [Online]. Available: <http://www.epa.gov/climatechange/ghgemissions/global.html>. [Accessed 20 January 2015].
- [2] International Energy Agency, "Key World Energy Statistics," International Energy Agency, 2014.
- [3] International Electrotechnical Commission, "Challenges in smart grid technology sectors," IEC, 2015. [Online]. Available: <http://www.iec.ch/smartgrid/challenges/>. [Accessed 29 March 2015].
- [4] Wikipedia, "Northeast Blackout of 2003," 16 June 2015. [Online]. Available: https://en.wikipedia.org/wiki/Northeast_blackout_of_2003.
- [5] T. Imura, H. Okabe and Y. Hori, "Basic experimental study on helical antennas of wireless power transfer for electric vehicles by using magnetic resonant couplings," *IEEE Vehicle Power and Propulsion Conference*, pp. 936-940, 2009.
- [6] B. Kantarci and H. T. Mouftah, "Energy efficiency in the extended-reach fiber-

wireless access networks," *IEEE Network*, vol. 26, no. 2, pp. 28-35, March-April 2012.

- [7] M. Jarrar and R. Jayasekera, "Upgrading from IPv4 to IPv6: challenges and opportunities," *Index on Censorship Special Issue on World Summit on Information Society (WSIS'03)*, April 2003.
- [8] International Electrotechnical Commission, "Smart Grid Standardization Roadmap," SMB Smart Grid Strategic Group, Geneva, June 2010.
- [9] Siemens, "Internet of Energy," Siemens Global Website, 6 September 2014. [Online]. Available: http://www.siemens.com/innovation/en/news/2014/e_inno_1424_2.htm.
- [10] M. Hashmi, S. Hanninen and K. Maki, "Survey of smart grid concepts, architectures, and technological demonstrations worldwide," *2011 IEEE PES Conference on Innovative Smart Grid Technologies (ISGT Latin America)*, pp. 1-7, 19-21 Oct. 2011.
- [11] Mercedes Benz, "Environmental Certificate," 2006 December 31. [Online]. Available: http://www3.mercedes-benz.com/fleet-sales/de/assets/documents/s-klasse_umweltzertifikat_d_e.pdf.
- [12] H. Farhangi, "The path of the smart grid," *IEEE Power and Energy Magazine*, vol. 8, no. 1, pp. 18-28, 2010.

- [13] A. Ipakchi and F. Albuyeh, "Grid of the future," *IEEE Power and Energy Magazine*, vol. 7, no. 2, pp. 52-62, 2009.
- [14] S. M. Amin and B. F. Wollenberg, "Toward a smart grid: power delivery for the 21st century," *IEEE Power and Energy Magazine*, vol. 3, no. 5, pp. 34-41, 2005.
- [15] M. G. Simoes, R. Roche, E. Kyriakides, S. Suryanarayanan, B. Blunier, K. D. McBee, P. H. Nguyen, P. F. Ribeiro and A. Miraoui, "A Comparison of Smart Grid Technologies and Progresses in Europe and the U.S.," *IEEE Transactions on Industry Applications*, vol. 48, no. 4, pp. 1154-1162, 2012.
- [16] X. Fang, S. Misra, G. Xue and D. Yang, "Smart Grid — The New and Improved Power Grid: A Survey," *IEEE Communications Surveys & Tutorials*, vol. 14, no. 4, pp. 944-980, 2012.
- [17] S. Galli, A. Scaglione and Z. Wang, "For the Grid and Through the Grid: The Role of Power Line Communications in the Smart Grid," *Proceedings of the IEEE*, vol. 99, no. 6, pp. 998-1027, June 2011.
- [18] W. Wang, Y. Xu and M. Khanna, "A survey on the communication architectures in smart grid," *Computer Networks*, vol. 55, no. 15, pp. 3604-3629, July 2011.
- [19] W. Su, H. Eichi, W. Zeng and M.-Y. Chow, "A Survey on the Electrification of Transportation in a Smart Grid Environment," *IEEE Transactions on Industrial*

Informatics, vol. 8, no. 1, pp. 1-10, 2012.

- [20] B. Akyol, H. Kirkham, S. Clements and M. Hadley, "A Survey of Wireless Communications for the Electric Power System," U.S. Department of Energy, Richland, Washington, 2010.
- [21] V. C. Gungor and F. C. Lambert, "A survey on communication networks for electric system automation," *Computer Networks*, vol. 50, no. 7, pp. 877-897, 2006.
- [22] R. Hassan and G. Radman, "Survey on Smart Grid," in *Proceedings of the IEEE SoutheastCon 2010 (SoutheastCon)*, Concord, NC, 2010.
- [23] M. Kim, "A survey on guaranteeing availability in smart grid communications," in *14th International Conference on Advanced Communication Technology (ICACT), 2012*, PyeongChang, 2012.
- [24] S. Bera, S. Misra and J. J. Rodrigues, "Cloud Computing Applications for Smart Grid: A Survey," *IEEE Transactions on Parallel and Distributed Systems*, vol. 26, no. 5, pp. 1477-1494, 2015.
- [25] M. Pipattanasomporn, H. Feroze and S. Rahman, "Multi-agent systems in a distributed smart grid: Design and implementation," in *IEEE/PES Power Systems Conference and Exposition, 2009. PSCE '09.*, Seattle, WA, 2009.

- [26] J. Varela, L. Puglisi, T. Wiedemann, U. Ysberg, D. Stein, Z. Pokorna, C. Arnoult, R. Garaud-Verdier and L. Consiglio, "Show Me!: Large-Scale Smart Grid Demonstrations for European Distribution Networks," *IEEE Power and Energy Magazine*, vol. 13, no. 1, pp. 84-91, 2015.
- [27] R. H. Lasseter, "Smart Distribution: Coupled Microgrids," *Proceedings of the IEEE*, vol. 99, no. 6, pp. 1074-1082, 2011.
- [28] L. F. Ochoa, A. Keane and G. P. Harrison, "Minimizing the Reactive Support for Distributed Generation: Enhanced Passive Operation and Smart Distribution Networks," *IEEE Transactions on Power Systems*, vol. 26, no. 4, pp. 2134-2142, November 2011.
- [29] H. Farhangi, "A Road Map to Integration: Perspectives on Smart Grid Development," *IEEE Power and Energy Magazine*, vol. 12, no. 3, pp. 52-66, 2014.
- [30] M. Kezunovic, V. Vittal, S. Meliopoulos and T. Mount, "The Big Picture: Smart Research for Large-Scale Integrated Smart Grid Solutions," *IEEE Power and Energy Magazine*, vol. 10, no. 4, pp. 22-34, 2012.
- [31] F. Rahimi and A. Ipakchi, "Demand Response as a Market Resource Under the Smart Grid Paradigm," *IEEE Transactions on Smart Grid*, vol. 1, no. 1, pp. 1949-3053, 2010.

- [32] P. Palensky and D. Dietrich, "Demand Side Management: Demand Response, Intelligent Energy Systems, and Smart Loads," *IEEE Transactions on Industrial Informatics*, vol. 7, no. 3, pp. 381-388, 2011.
- [33] A.-H. Mohsenian-Rad, V. W. S. Wong, J. Jatskevich and R. Schober, "Autonomous Demand-Side Management Based on Game-Theoretic Energy Consumption Scheduling for the Future Smart Grid," *IEEE Transactions on Smart Grid*, vol. 1, no. 3, pp. 320-331, 2010.
- [34] Z. M. Fadlullah, D. M. Quan, N. Kato and I. Stojmenovic, "GTES: An Optimized Game-Theoretic Demand-Side Management Scheme for Smart Grid," *IEEE Systems Journal*, vol. 8, no. 2, pp. 588-597, 2014.
- [35] US Federal Energy Regulatory Commission, "Assessment of demand response & advanced metering," December 2008. [Online]. Available: <http://www.ferc.gov/legal/staff-reports/12-08-demand-response.pdf>. [Accessed 29 July 2014].
- [36] Electric Light and Power Magazine, "AMR vs AMI," PennWell's Global Energy Group, 1 October 2008. [Online]. Available: http://www.elp.com/articles/powergrid_international/print/volume-13/issue-10/features/amr-vs-ami.html. [Accessed 10 February 2014].

- [37] Z. M. Fadlullah, M. M. Fouda, N. Kato, A. Takeuchi, N. Iwasaki and Y. Nozaki, "Toward intelligent machine-to-machine communications in smart grid," *IEEE Communications Magazine*, vol. 49, no. 4, pp. 60-65, 2011.
- [38] C. Cuijpers and B.-J. Koops, "Smart Metering and Privacy in Europe: Lessons from the Dutch Case," Social Science Research Network, Tilburg, Netherlands, 2013.
- [39] Information and Privacy Commissioner, "Building Privacy into Ontario's Smart Meter Data Management System: A Control Framework," Independent Electricity System Operator, Toronto, Ontario, May, 2012.
- [40] BC Hydro, "Smart meter security and your privacy," BC Hydro, 19 February 2015. [Online]. Available: https://www.bchydro.com/energy-in-bc/projects/smart_metering_infrastructure_program/faqs/security_and_privacy.html. [Accessed 10 April 2015].
- [41] SmartGrid.Gov, "Data Privacy and the Smart Grid: A Voluntary Code of Conduct," Federal Smart Grid Initiatives, 12 January 2015. [Online]. Available: https://www.smartgrid.gov/federal_initiatives/featured_initiatives/data_privacy_and_smart_grid_voluntary_code_conduct. [Accessed 4 April 2015].
- [42] Victoria State Government, "Smart Meters," Department of Economic Development, Jobs, Transport and Resources, Victoria, Australia, 28 March 2015.

- [Online]. Available: <http://www.smartmeters.vic.gov.au/privacy>. [Accessed 8 April 2015].
- [43] F. Skopika, Z. Maa, T. Bleiera and H. Grüneisb, "A Survey on Threats and Vulnerabilities in Smart Metering Infrastructures," *International Journal of Smart Grid and Clean Energy*, vol. 1, no. 1, pp. 22-28, September 2012.
- [44] R. Anderson and S. Fuloria, "Smart meter security: a survey," cl.cam.ac.uk, 2011. [Online]. Available: <http://www.cl.cam.ac.uk/~rja14/Papers/JSAC-draft.pdf>. [Accessed 27 September 2013].
- [45] M. Jawurek, F. Kerschbaum and G. Danezis, "Privacy Technologies for Smart Grids – A Survey of Options.," Microsoft Technical Report, November 2012.
- [46] Nissan Newsroom Europe, "Much more than a 'second car'," Nissan, 15 March 2015. [Online]. Available: <http://newsroom.nissan-europe.com/EU/en-gb/Media/Media.aspx?mediaid=130792>. [Accessed 20 April 2015].
- [47] S. Shao, M. Pipattanasomporn and S. Rahman, "Challenges of PHEV penetration to the residential distribution network," in *PES '09. IEEE Power & Energy Society General Meeting*, , Calgary, AB, July 2009.
- [48] K. Clement, E. Haesen and J. Driesen, "Coordinated charging of multiple plug-in hybrid electric vehicles in residential distribution grids," in *PSCE '09. IEEE/PES Power*

Systems Conference and Exposition, 2009. , Seattle, WA, March 2009.

- [49] S. W. Hadley, "Evaluating the impact of Plug-in Hybrid Electric Vehicles on regional electricity supplies," in *iREP Symposium on Bulk Power System Dynamics and Control - VII. Revitalizing Operational Reliability*, Charleston, SC, 2007.
- [50] J. Taylor, A. Maitra, M. Alexander, D. Brooks and M. Duvall, "Evaluation of the impact of plug-in electric vehicle loading on distribution system operations," in *PES '09. IEEE Power & Energy Society General Meeting*, Calgary, AB, 2009.
- [51] E. Sortomme, M. M. Hindi, S. D. J. MacPherson and S. S. Venkata, "Coordinated Charging of Plug-In Hybrid Electric Vehicles to Minimize Distribution System Losses," *IEEE Transactions on Smart Grid*, vol. 2, no. 1, pp. 198-205, 2011.
- [52] H. Turker, S. Bacha and A. Hably, "Rule-Based Charging of Plug-in Electric Vehicles (PEVs): Impacts on the Aging Rate of Low-Voltage Transformers," *IEEE Transactions on Power Delivery*, vol. 29, no. 3, pp. 1012-1019, June 2014.
- [53] C. Jin, J. Tang and P. Ghosh, "Optimizing Electric Vehicle Charging: A Customer's Perspective," *IEEE Transactions on Vehicular Technology*, vol. 62, no. 7, pp. 2919-2927, Sept. 2013.
- [54] Q. Gong, Y. Li and Z.-R. Peng, "Trip-Based Optimal Power Management of Plug-in Hybrid Electric Vehicles," *IEEE Transactions on Vehicular Technology*, vol. 57, no. 6,

pp. 3393-3401, November 2008.

- [55] A. Malikopoulos, "Supervisory Power Management Control Algorithms for Hybrid Electric Vehicles: A Survey," *IEEE Transactions on Intelligent Transportation Systems*, vol. 15, no. 5, pp. 1869-1885, Oct. 2014.
- [56] Y.-J. Lee, A. Khaligh and A. Emadi, "Advanced Integrated Bidirectional AC/DC and DC/DC Converter for Plug-In Hybrid Electric Vehicles," *Vehicular Technology, IEEE Transactions on*, vol. 58, no. 8, pp. 3970-3980, 2009.
- [57] A. F. Burke, "Batteries and Ultracapacitors for Electric, Hybrid, and Fuel Cell Vehicles," *Proceedings of the IEEE*, vol. 95, no. 4, pp. 806-820, 2007.
- [58] A. Hajimiragha, C. A. Canizares, M. W. Fowler and A. Elkamel, "Optimal Transition to Plug-In Hybrid Electric Vehicles in Ontario, Canada, Considering the Electricity-Grid Limitations," *IEEE Transactions on Industrial Electronics*, , vol. 57, no. 2, pp. 690-701, 2010.
- [59] S. Han, S. Han and K. Sezaki, "Development of an Optimal Vehicle-to-Grid Aggregator for Frequency Regulation," *IEEE Transactions on Smart Grid*, vol. 1, no. 1, pp. 1949-3053, 2010.
- [60] Z. Wang and S. Wang, "Grid Power Peak Shaving and Valley Filling Using Vehicle-to-Grid Systems," *IEEE Transactions on Power Delivery*, vol. 28, no. 3, pp.

1822-1829, 2013.

- [61] D. E. Bakken, A. Bose, C. H. Hauser, D. E. Whitehead and G. C. Zweigle, "Smart Generation and Transmission With Coherent, Real-Time Data," *Proceedings of the IEEE*, vol. 99, no. 6, pp. 928-951, 2011.
- [62] L. F. Ochoa and G. P. Harrison, "Minimizing Energy Losses: Optimal Accommodation and Smart Operation of Renewable Distributed Generation," *IEEE Transactions on Power Systems*, vol. 26, no. 1, pp. 198-205, 2011.
- [63] F. Li, W. Qiao, H. Sun, H. Wan, J. Wang, Y. Xia, Z. Xu and P. Zhang, "Smart Transmission Grid: Vision and Framework," *IEEE Transactions on Smart Grid (Volume:1 , Issue: 2)*, vol. 1, no. 2, pp. 168-177, August, 2010.
- [64] M. Maier, M. Levesque and L. Ivanescu, "NG-PONs 1&2 and beyond: the dawn of the uber-FiWi network," *IEEE Network*, vol. 26, no. 2, pp. 15-21, March-April 2012.
- [65] A. M. J. Koonen and E. Tangdionga, "Photonic Home Area Networks," *Journal of Lightwave Technology*, vol. 32, no. 4, pp. 591-604, 2014.
- [66] V. C. Gungor, B. Lu and G. P. Hancke, "Opportunities and Challenges of Wireless Sensor Networks in Smart Grid," *IEEE Transactions on Industrial Electronics*, vol. 57, no. 10, pp. 3557-3564, Oct. 2010.

- [67] T. Baumeister, "Literature Review on Smart Grid Cyber Security," December 2010. [Online]. Available: <https://csdl-techreports.googlecode.com/svn/trunk/techreports/2010/10-11/10-11.pdf>. [Accessed 10 November 2013].
- [68] W. Wang and Z. Lu, "<http://www.sciencedirect.com/science/article/pii/S1389128613000042>," *Computer Networks*, vol. 57, no. 5, pp. 1344-1371, April 2013.
- [69] Y. Yan, Y. Qian, H. Sharif and D. Tipper, "A Survey on Cyber Security for Smart Grid Communications," *IEEE Communications Surveys & Tutorials*, vol. 14, no. 4, pp. 998-1010, 2012.
- [70] M. Uslar, S. Rohjans, R. Bleiker, J. González, M. Specht, T. Suding and T. Weidelt, "Survey of Smart Grid Standardization Studies and Recommendations," in *2010 First IEEE International Conference on Smart Grid Communications (SmartGridComm)*, Gaithersburg, MD, 2010.
- [71] M. Uslar, S. Rohjans, R. Bleiker, J. Gonzalez, M. Specht, T. Suding and T. Weidelt, "Survey of Smart Grid standardization studies and recommendations — Part 2," in *IEEE PES Innovative Smart Grid Technologies Conference Europe (ISGT Europe)*, Gothenburg, 2010.

- [72] J. Vasconcelos, "Survey of Regulatory and Technological Developments Concerning Smart Metering in the European Union Electricity Market," EUI Robert Schuman Centre for Advanced Studies, 2008.
- [73] J. Wang and V. C. M. Leung, "A survey of technical requirements and consumer application standards for IP-based smart grid AMI network," in *2011 International Conference on Information Networking (ICOIN)*, Barcelona, 2011.
- [74] J. M. Guerrero, J. C. Vasquez, J. Matas, L. G. de Vicuña and M. Castilla, "Hierarchical Control of Droop-Controlled AC and DC Microgrids—A General Approach Toward Standardization," *IEEE Transactions on Industrial Electronics*, vol. 58, no. 1, pp. 158-172, 2010.
- [75] Z. Feng and Z. Yuexia, "Study on smart grid communications system based on new generation wireless technology," in *2011 International Conference on Electronics, Communications and Control (ICECC)*, , Ningbo, Sept 2011.
- [76] S. Komaki, "Heterogeneous cognitive radio on fiber technologies for university and/or community smart grids," in *IEEE 4th International Conference on Photonics (ICP)*, Melaka, Oct 2013.
- [77] S. Sarkar, S. Dixit and B. Mukherjee, "Hybrid Wireless-Optical Broadband-Access Network (WOBAN): A Review of Relevant Challenges," *Journal of Lightwave*

Technology, vol. 25, no. 11, pp. 3329-3340, December 2007.

- [78] N. Ghazisaidi and M. Maier, "Fiber-wireless (FiWi) access networks: Challenges and opportunities," *IEEE Network*, vol. 25, no. 1, pp. 36 - 42. , January-February 2011.
- [79] S. Xu, "Research on the access of Radio-on-Fiber in power communication," in *International Conference on Automatic Control and Artificial Intelligence (ACAI 2012)*, , Xiamen, 2012.
- [80] A. Cooper, "Fibre/radio for the provision of cordless/mobile telephony services in the access network," *Electronics Letters*, vol. 26, no. 24, pp. 2054-2056, 22 Nov 1990.
- [81] Z. Jia, J. Yu and G.-K. Chang, "A full-duplex radio-over-fiber system based on optical carrier suppression and reuse," *IEEE Photonics Technology Letters* , vol. 18, no. 16, pp. 1726-1728, Aug. 2006.
- [82] L. Chen, H. Wen and S. Wen, "A Radio-Over-Fiber system with a novel scheme for millimeter-wave generation and wavelength reuse for up-link connection," *IEEE Photonics Technology Letters*, vol. 18, no. 19, pp. 2056-2058, Oct.1, 2006.
- [83] J. Yu, J. Gu, X. Liu, Z. Jia and G.-K. Chang, "Seamless integration of an 8×2.5 Gb/s WDM-PON and radio-over-fiber using all-optical up-conversion based on Raman-assisted FWM," *IEEE Photonics Technology Letters*, vol. 17, no. 9, pp. 1986-1988, Sept

2005.

- [84] J. Yu, Z. Jia, L. Xu, L. Chen, T. Wang and G.-K. Chang, "DWDM optical millimeter-wave generation for radio-over-fiber using an optical phase modulator and an optical interleaver," *IEEE Photonics Technology Letters*, vol. 18, no. 13, pp. 1418-1420, July

2006.

- [85] M. Larrode, A. Koonen, J. Olmos and A. Ng'oma, "Bidirectional radio-over-fiber link employing optical frequency multiplication," *IEEE Photonics Technology Letters*, vol. 18, no. 1, pp. 241-243, Jan, 2006.

- [86] H. B. Kim, M. Emmelmann, B. Rathke and A. Wolisz, "A radio over fiber network architecture for road vehicle communication systems," *IEEE 61st Vehicular Technology Conference*, vol. 5, pp. 2920-2924, May-June 2005.

- [87] M. Bakaul, A. Nirmalathas and C. Lim, "Multifunctional WDM optical interface for Millimeter-wave fiber-radio antenna base station," *Journal of Lightwave Technology*, vol. 23, no. 3, pp. 1210-1218, March 2005.

- [88] W.-P. Lin, "A robust fiber-radio architecture for wavelength-division-multiplexing ring-access networks," *Journal of Lightwave Technology*, vol. 23, no. 9, pp. 2610-2620, Sept 2005.

- [89] H.-J. Song, J. S. Lee and J.-I. Song, "Error-free simultaneous all-optical

- upconversion of WDM radio-over-fiber signals," *IEEE Photonics Technology Letters*, vol. 17, no. 8, pp. 1731-1733, Aug 2005.
- [90] X. Zhang, B. Liu, J. Yao, K. Wu and R. Kashyap, "A novel millimeter-wave-band radio-over-fiber system with dense wavelength-division multiplexing bus architecture," *IEEE Transactions on Microwave Theory and Techniques*, vol. 54, no. 2, pp. 929-937, Feb 2006.
- [91] C. S. Park, C. K. Oh, C. G. Lee, D.-H. Kim and C.-S. Park, "A photonic up-converter for a WDM radio-over-fiber system using cross-absorption modulation in an EAM," *IEEE Photonics Technology Letters*, vol. 17, no. 9, pp. 1950-1952, Sept. 2005.
- [92] K. Xu, X. Sun, J. Yin, H. Huang, J. Wu, X. Hong and J. Lin, "Enabling ROF Technologies and Integration Architectures for In-Building Optical–Wireless Access Networks," *IEEE Photonics Journal*, vol. 2, no. 2, pp. 102-112, April 2010.
- [93] H.-H. Lu, S.-J. Tzeng and Y.-L. Liu, "Intermodulation distortion suppression in a full-duplex radio-on-fiber ring network," *IEEE Photonics Technology Letters*, vol. 16, no. 2, pp. 602-604, 2004.
- [94] M. Sauer, A. Kobayakov and J. George, "Radio Over Fiber for Picocellular Network Architectures," *Journal of Lightwave Technology*, vol. 25, no. 11, pp. 3301 - 3320, November 2007.

- [95] Z. Chunlei, G. Ling and Z. Pengtu, "An overview of integration of RoF with PON," in *International Conference on Computer Application and System Modeling (ICCASM)*, Taiyuan, Oct 2010.
- [96] K. Maamoun and H. Mouftah, "A survey and a novel scheme for RoF-PON as FTTx wireless services," *6th International Symposium High-Capacity Optical Networks and Enabling Technologies (HONET)*, pp. 246-253, 28-30 Dec. 2009.
- [97] K. M. Maamoun and H. T. Mouftah, "Survivability models for radio-over-fiber passive optical networks (RoF-PON)," in *IEEE Seventh International Computer Engineering Conference (ICENCO)*, Giza, Dec 2011.
- [98] F. I. El-Nahal, "Bidirectional WDM-Radio over Fiber System with Sub Carrier Multiplexing Using a Reflective SOA and Cyclic AWGs," (*IJACSA*) *International Journal of Advanced Computer Science and Applications*,, vol. 2, no. 8, pp. 93 - 96, 2011.
- [99] D. Wake, A. Nkansah and N. J. Gomes, "Radio Over Fiber Link Design for Next Generation Wireless Systems," *Journal of Lightwave Technology*, vol. 28, no. 16, pp. 2456-2464, Aug 2010.
- [100] D. Wake, A. Nkansah, N. J. Gomes, G. De Valicourt, R. Brenot, M. Violas, Z. Liu, F. Ferreira and S. Pato, "A Comparison of Radio Over Fiber Link Types for the Support of Wideband Radio Channels," *Journal of Lightwave Technology*, vol. 28, no. 16, pp.

2416-2422, August 2010.

- [101] H. Singh, M. L. Singh and R. Singh, "A novel full duplex 16 Gbps SCM/ASK radio over fiber WDM-PON sharing wavelength for up- and down-link using bidirectional reflective filter," *International Journal for Light and Electron Optics*, vol. 125, no. 14, pp. 3473-3475, July 2014.
- [102] M. Zhu, L. Zhang, J. Wang, L. Cheng, C. Liu and G.-K. Chang, "Radio-Over-Fiber Access Architecture for Integrated Broadband Wireless Services," *Journal of Lightwave Technology*, vol. 31, no. 23, pp. 3614-3620, Dec 2013.
- [103] W. Ji and J. Chang, "Design of WDM-RoF-PON for wireless and wire-line access with source-free ONUs," *IEEE/OSA Journal of Optical Communications and Networking*, vol. 5, no. 2, pp. 127-133, 2013.
- [104] W. Ji and Z. Kang, "Design of WDM RoF PON based on OFDM and optical heterodyne," *IEEE/OSA Journal of Optical Communications and Networking*, vol. 5, no. 6, pp. 652-657, 2013.
- [105] Z. Cao, J. Yu, H. Zhou, W. Wang, M. Xia, J. Wang, Q. Tang and L. Chen, "WDM-RoF-PON Architecture for Flexible Wireless and Wire-Line Layout," *IEEE/OSA Journal of Optical Communications and Networking*, vol. 2, no. 2, pp. 117-121, 2010.
- [106] M. Zhu, L. Zhang, S.-H. Fan, C. Su, G. Gu and G.-K. Chang, "Efficient Delivery of

- Integrated Wired and Wireless Services in UDWDM-RoF-PON Coherent Access Network," *IEEE Photonics Technology Letters*, vol. 24, no. 13, pp. 1127-1129, 2012.
- [107] Y.-T. Hsueh, M.-F. Huang, S.-H. Fan and G.-K. Chang, "A Novel Lightwave Centralized Bidirectional Hybrid Access Network: Seamless Integration of RoF With WDM-OFDM-PON," *IEEE Photonics Technology Letters*, vol. 23, no. 15, pp. 1085-1087, 2011.
- [108] SA Transcripts, "AT&T's CEO Discusses Q1 2012 Results - Earnings Call Transcript," 24 April 2012. [Online]. Available: <http://seekingalpha.com/article/522271-at-and-ts-ceo-discusses-q1-2012-results-earnings-call-transcript?part=single>. [Accessed 22 December 2014].
- [109] B. Ballal and S. Nema, "Performance Comparison of Analog and Digital Radio Over Fiber Link," *International Journal of Computer Science & Engineering Technology (IJCSSET)*, vol. 3, no. 6, pp. 193-198, 2012.
- [110] A. Haddad and M. Gagnaire, "Radio-over-Fiber (RoF) for mobile backhauling: A technical and economic comparison between analog and digitized RoF," in *International Conference on Optical Network Design and Modeling*, Stockholm, May 2014.
- [111] J. Y. a. Z. J. Gee-Kung Chang, "Architectures and enabling technologies for

- super-broadband Radio-over-Fiber optical-wireless access networks," *IEEE International Topical Meeting on Microwave Photonics*, p. pp. 24 – 28, 2007.
- [112] S. Xu, "Research on the access of Radio-on-Fiber in power communication," in *International Conference on Automatic Control and Artificial Intelligence (ACAI 2012)*,,, Xiamen, 2012.
- [113] J. Guillory, Radio over Fiber for the Future Home Area Networks, Paris: PhD Thesis, University of Paris-Est, October 2012.
- [114] N. Zaker, MSc Thesis: Fiber-wireless Sensor Broadband Access Network Integration for the Smart Grid, Ottawa: University of Ottawa, 2013.
- [115] A. R. Chraplyvy, "Limitations on lightwave communications imposed by optical-fiber nonlinearities," *Lightwave Technology, Journal of* , vol. 8, no. 10, pp. 1548 - 1557, Oct 1990.
- [116] S. T. A. a. S. M. Kawanishi, "Wide-band frequency response measurement of optical receivers using optical heterodyne detection," *Journal of Lightwave Technology*, vol. 1, pp. 92-98, 1988.
- [117] A. J. Seeds and A. A. A. De Salles, "Optical control of microwave semiconductor devices," *IEEE Transactions*, vol. 5, pp. 577-585, 1990.

- [118] T. S. Tan, R. L. Jungerman and S. S. Elliot, "Calibration of optical receivers and modulators using an optical heterodyne technique," *Proceedings of IEEE Microwave Theory and Techniques Symposium*, pp. 1067-1070, 1988.
- [119] J. J. O'Reilly, P. M. Lane, R. Heidemann and R. Hofstetter, "Optical generation of very narrow linewidth millimetre wave signals," *Electronics Letters*, vol. 28, no. 25, pp. 2309-2310, 1992.
- [120] S. Yoo, "Wavelength conversion technologies for WDM network applications," *Journal of Lightwave Technology*, vol. 14, no. 6, pp. 955-966, 2002.
- [121] J. Zhou, N. Park, J. W. Dawson, K. Vahala, M. A. Newkirk and B. I. Miller, "Efficiency of broadband four-wave mixing wavelength conversion using semiconductor traveling-wave amplifiers," *IEEE Photonics Technology Letters*, vol. 6, no. 1, pp. 50-52, 2002.
- [122] J. Zhou, N. Park, K. Vahala, M. A. Newkirk and B. I. Miller, "Four-wave mixing wavelength conversion efficiency in semiconductor traveling-wave amplifiers measured to 65 nm of wavelength shift," *IEEE Photonics Technology Letters*, vol. 6, no. 8, pp. 984-987, 2002.
- [123] T. Durhuus, B. Mikkelsen, C. Joergensen, S. Danielsen and K. Stubkjaer, "All-optical wavelength conversion by semiconductor optical amplifiers," *Journal of*

Lightwave Technology, vol. 14, no. 6, pp. 942-954, 2002.

- [124] International Telecommunication Union, "Broadband optical access systems based on Passive Optical Networks (G.983.1)," ITU-T, Geneva, 2005.
- [125] N. Ghazisaidi, M. Scheutzow and M. Maier, "Survivability Analysis of Next-Generation Passive Optical Networks and Fiber-Wireless Access Networks," *IEEE Transactions on Reliability*, vol. 60, no. 2, pp. 479-492, June 2011.
- [126] International Telecommunication Union , "Spectral grids for WDM applications: DWDM frequency grid (ITU-T G.694.1)," ITU-T, Geneva, Switzerland, 06/2012.