

## INFORMATION TO USERS

This manuscript has been reproduced from the microfilm master. UMI films the text directly from the original or copy submitted. Thus, some thesis and dissertation copies are in typewriter face, while others may be from any type of computer printer.

**The quality of this reproduction is dependent upon the quality of the copy submitted.** Broken or indistinct print, colored or poor quality illustrations and photographs, print bleedthrough, substandard margins, and improper alignment can adversely affect reproduction.

In the unlikely event that the author did not send UMI a complete manuscript and there are missing pages, these will be noted. Also, if unauthorized copyright material had to be removed, a note will indicate the deletion.

Oversize materials (e.g., maps, drawings, charts) are reproduced by sectioning the original, beginning at the upper left-hand corner and continuing from left to right in equal sections with small overlaps.

ProQuest Information and Learning  
300 North Zeeb Road, Ann Arbor, MI 48106-1346 USA  
800-521-0600

**UMI**<sup>®</sup>



THERMOCHEMICAL AND KINETIC STUDIES  
OF SOME ORGANIC SYSTEMS

by  
EDWARD G. LOVERING

A thesis submitted in partial fulfillment  
of the requirements for the degree of

DOCTOR OF PHILOSOPHY

in the

DEPARTMENT OF CHEMISTRY

UNIVERSITY OF OTTAWA

Ottawa, Canada

1961

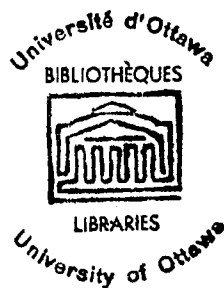

K. J. Laidler,  
Professor of Chemistry,  
Research Supervisor.

E. G. Lovering  
Ph. D. Candidate.

UMI Number: DC52467

### INFORMATION TO USERS

The quality of this reproduction is dependent upon the quality of the copy submitted. Broken or indistinct print, colored or poor quality illustrations and photographs, print bleed-through, substandard margins, and improper alignment can adversely affect reproduction.

In the unlikely event that the author did not send a complete manuscript and there are missing pages, these will be noted. Also, if unauthorized copyright material had to be removed, a note will indicate the deletion.

**UMI<sup>®</sup>**

---

UMI Microform DC52467  
Copyright 2007 by ProQuest LLC  
All rights reserved. This microform edition is protected against  
unauthorized copying under Title 17, United States Code.

---

ProQuest LLC  
789 East Eisenhower Parkway  
P.O. Box 1346  
Ann Arbor, MI 48106-1346

PREFACE

Before beginning an experimental investigation into some of the thermodynamic properties of compounds and reactions of importance in the manufacture of polyurethanes, it was decided to devise, if possible, an empirical bond-energy scheme which would enable certain thermodynamic properties of the materials concerned to be calculated.

In view of the lack of thermodynamic data concerning alcohol-isocyanate reactions, it was decided to measure the heat of reaction for a series of simple reactions of this type. While this work was in progress it became apparent that kinetic rate constants could be calculated from the data obtained during the course of the heat of reaction measurements. In order to verify the rate constants so calculated the rates of these reactions were also measured using an analytical technique.

ACKNOWLEDGEMENT

I would like to express my thanks to Professor Laidler for his guidance, and for many helpful discussions, during the course of this work. In addition, I wish to

thank the staff of the Computing Center at this University for carrying out the least squares calculations; Miss Elizabeth Busk for the carbon and hydrogen analyses of certain urethanes ; Mr. L. A. Dickenson of the Canadian Armament Research and Development Establishment for supplying certain chemicals, and Mr. Othman bin M. Nor for calculating the rate constants from the thermodynamic data. I also wish to thank my wife for her help during the writing of this thesis. This work was supported by the Defence Research Board under Grant No. D. R. B. 1028-28.

TABLE OF CONTENTS

PREFACE	ii
TABLE OF CONTENTS	iv
LIST OF TABLES	vii
LIST OF FIGURES	ix
ABSTRACT	xi

PART IA BOND ADDITIVITY SCHEME FOR SULPHUR AND OXYGEN COMPOUNDS 1

INTRODUCTION	1
THEORETICAL AND EMPIRICAL CONSIDERATIONS	4
Heats of Formation and Atomization	4
The Empirical Scheme	7
CALCULATIONS	9
Heats of Atomization and Vaporization of Sulphur Compounds	9
Heats of Atomization of Oxygen Compounds	11
Heats of Formation and Combustion	18
DISCUSSION	23

PART IIHEATS OF REACTION 24

INTRODUCTION	24
EXPERIMENTAL	26

The Calorimeter	26
The Reaction Cell Assembly	31
The Relationship between the Heat Liberated in the Calorimeter and the Voltage-Time Curve	34
Calibration of the Calorimeter	35
Purity of Materials	37
Experimental Procedure	46
EXPERIMENTAL RESULTS	48
DISCUSSION	56

### PART III

#### KINETICS OF REACTION 66

INTRODUCTION	66
Rate Constants by Chemical Analysis	66
Thermal Method	68
The Kinetics of Alcohol Isocyanate Reactions	73
EXPERIMENTAL	84
Purity of Materials	84
Analysis of Isocyanate Groups	84
Constant Temperature Baths	85
Experimental Procedure	86
Calculation of the Rate Constants from Chemical Analysis Data	88
Calculation of the Rate Constants from Calorimetric Data	89

EXPERIMENTAL RESULTS	90
Phenyl Isocyanate Reactions	90
o-Tolyl Isocyanate Reactions	94
m-Tolyl Isocyanate Reactions	98
p-Tolyl Isocyanate Reactions	102
Calculated Results	102
DISCUSSION OF THE RESULTS	107
Calorimetric Rate Constants	107
Kinetics of Alcohol Isocyanate Reactions	111
CLAIMS TO ORIGINAL RESEARCH	116
REFERENCES	117

LIST OF TABLES

I	Bond Strengths for Sulphur Compounds	10
II	Sulphur Compounds: Heats of Atomization	12
III	Bond Contributions to the Heat of Vaporization of Sulphur Compounds	14
IV	Heats of Vaporization of Sulphur Compounds	15
V	Bond Strengths for Oxygen Compounds	16
VI	Oxygen Compounds: Heats of Atomization	17
VII	Bond Contributions to Heats of Atomization, Formation, and Combustion of Sulphur- and Oxygen-containing Liquids and Gases	22
VIII	Boiling Points and Pressures of Isocyanates	40
IX	<u>N</u> -Phenyl Urethane Melting Points	41
X	<u>N</u> - <i>m</i> -Tolyl Urethanes: Boiling Points and Analytical Results	43
XI	<u>N,N</u> -2,4-Tolylene Diisocyanate Urethanes: Melting Points and Analytical Results	45
XII	The Heat of Phenyl Isocyanate Reactions at 25°C.	50
XIII	The Heat of <i>o</i> -Tolyl Isocyanate Reactions at 25°C.	51
XIV	The Heat of <i>m</i> -Tolyl Isocyanate Reactions at 25°C.	52
XV	The Heat of <i>p</i> -Tolyl Isocyanate Reactions at 25°C.	53
XVI	The Heat of 2,4-Tolylene Diisocyanate Reactions at 25°C.	54
XVII	Summary of Heats of Reaction	55

XVIII	Calculated Heats of Formation of Urethanes at 25 <sup>o</sup> C.	60
XIX	Rate Constants for Phenyl Isocyanate Reactions	91
XX	Calorimetric Rate Constants for Phenyl Isocyanate Reactions	91
XXI	Rate Constants for o-Tolyl Isocyanate Reactions	95
XXII	Rate Constants for m-Tolyl Isocyanate Reactions	99
XXIII	Calorimetric Rate Constants for m-Tolyl Isocyanate Reactions	99
XXIV	Rate Constants for p-Tolyl Isocyanate Reactions	103
XXV	Calorimetric Rate Constants for p-Tolyl Isocyanate Reactions	103
XXVI	Calculated Results at 25 <sup>o</sup> C.	106
XXVII	Summary of Calorimetric Rate Constants at 25 <sup>o</sup> C.	108

LIST OF FIGURES

1	Schematic diagram of the calorimeter	27
2a	Schematic diagram of the basic amplifier circuit	30
2b	Schematic diagram of the basic integrator circuit	30
3	The reaction cell assembly	32
4a	Amplifier chart for a chemical reaction	72
4b	Integrator chart for a chemical reaction	72
4c	Amplifier chart for an electrical heating	72
4d	Integrator chart for an electrical heating	72
5	Ephraim's data: log rate constant plotted against the reciprocal of the dielectric constant for the reaction of phenyl isocyanate with methyl alcohol in a series of solvents	82
6	Phenyl isocyanate reactions: log rate plotted against log isocyanate concentration at 25 <sup>o</sup> , 15 <sup>o</sup> , and 5 <sup>o</sup> C.	92
7	Phenyl isocyanate reactions: log rate constant plotted against the reciprocal of the absolute temperature	93
8	o-Tolyl isocyanate reactions: log rate plotted against log isocyanate concentration at 35 <sup>o</sup> , 25 <sup>o</sup> , and 15 <sup>o</sup> C.	96
9	o-Tolyl isocyanate reactions: log rate constant plotted against the reciprocal of the absolute temperature	97

- 10 m-Tolyl isocyanate reactions: log rate plotted against log isocyanate concentration at 25°, 15°, 7°, and 0°C. 100
- 11 m-Tolyl isocyanate reactions: log rate constant plotted against the reciprocal of the absolute temperature. 101
- 12 p-Tolyl isocyanate reactions: log rate plotted against log isocyanate concentration at 25°, 15°, and 0°C. 104
- 13 p-Tolyl isocyanate reactions: log rate constant plotted against the reciprocal of the absolute temperature 105
- 14 Calorimetric calculations: time versus time difference curves 110
- 15 Arrhenius activation energy as a function of the free energy of activation 113

ABSTRACTThe Bond Additivity Scheme

The bond additivity scheme developed by Laidler has been extended to include certain sulphur and oxygen containing compounds. The compounds treated are the alkanethiols, the thiaalkanes and the dithiaalkanes. The bond energy scheme enables reliable values for the heats of formation, atomization, combustion, and vaporization to be calculated for these compounds. A similar treatment has been applied to the data for alcohols, ethers, and alkyl peroxides enabling heats of formation, atomization and combustion to be calculated.

The Heat of Alcohol-Isocyanate Reactions

The heats of various alcohol-isocyanate reactions have been measured at 25°C. under atmospheric pressure. The alcohols involved were normal, iso, and secondary butyl, and the isocyanates were phenyl, o-tolyl, m-tolyl, and p-tolyl, as well as 2,4-tolylene diisocyanate. The heat of the reaction between each alcohol and each isocyanate was measured. In certain cases, the reaction was catalysed with dimethyl cetyl amine or ferric acetylacetonate. The reaction product was analysed to ascertain that it was in fact a urethane, and that there were no major side reactions.

Making use of the measured heats of reaction, and the heats of combustion of ethyl isocyanate and the butyl alcohols reported in the literature, heats of formation of the reactant isocyanate and the product urethanes were estimated.

### Kinetics of Alcohol-Isocyanate Reactions

The rate constants of some of the above-mentioned reactions were determined from the calorimetric data. In order to verify the accuracy of the method used to calculate these constants, the kinetics of the reactions were studied by an analytical technique. The reactions were studied at a series of temperatures so that activation energies could be calculated. It was found that rate constants determined by the two methods were in good agreement. In addition, a review of the kinetics of the alcohol-isocyanate reactions has been given. The experimental data reported here are shown to support the previously suggested reaction mechanism.

PART I

A BOND ADDITIVITY SCHEME FOR SULPHUR AND OXYGEN COMPOUNDS

INTRODUCTION

It has been known for many years that the heats of combustion of compounds in a homologous series are additive; that is, if the heat of combustion of one member of a homologous series is known, then the heat of combustion of lower or higher members is readily calculated by subtracting or adding an appropriate amount to the known heat of combustion. When good experimental data are available additivity schemes can yield calculated heats of combustion which are nearly as accurate as those determined experimentally. Ultimately, as more good data become available, it will be possible to develop a scheme such that the heat of combustion of any organic compound can be calculated with confidence.

Early empirical schemes for the calculation of heats of combustion were given by Clark (1), Swietoslawski (2), and Kharasch (3, 4). The treatment of Kharasch and Shur is interesting. They postulate that the heat of combustion is due to the change in the position of

the electrons, relative to the nuclei, which occurs upon combustion. They also postulate that each such change liberates the same amount of heat. Hence one should be able to count the number of electrons which change position when a compound undergoes combustion, multiply by the proper factor, and obtain the heat of combustion. Special terms were calculated for functional groups.

In 1939, Pauling (5) suggested the use of bonds in an additivity scheme for the calculation of heats of combustion. From an empirical point of view this scheme is the same as Kharasch's, but it has the advantage that bonds are much easier to count than electrons. Although Kharasch attributed the heat effect of combustion to electron movement, his scheme is empirical and is equivalent to a scheme which considers all bonds between the same atoms to make an equal contribution to the heat of combustion, regardless of their environment. This is also true of Swietoslowski's treatment. Schemes of this type, which will be referred to as first-order schemes, yield calculated heats of combustion within one or two percent of the experimental value. Accuracy of this order in a heat of combustion is not adequate.

Better results are obtained if the scheme used has more than one or two variables. For example, in a bond scheme, allowance should be made for the environment of the bond, as well as its nature. When this is done

calculated heats of combustion are in very good agreement with the values determined experimentally. Tatevskii (6,7,8) has shown that heats of combustion in good agreement with experimental values can be calculated for the paraffins using three different types of carbon-hydrogen bonds, and ten types of carbon-carbon bonds.

A theoretical treatment of interactions between non-bonded atoms has been given by Bernstein (9), from the point of view of their effect on additive molecular properties of homologous series. The treatment, although very elegant from a mathematical point of view, is probably over-sophisticated for the amount of data available in the majority of cases.

An empirical scheme giving bond contributions to certain additive properties of hydrocarbon homologous series has been given by Laidler (10). This scheme, which is a simplification of Bernstein's treatment, makes allowance only for near-neighbour interactions. One type of single carbon-carbon bond is recognized, along with three types of carbon-hydrogen bonds, primary, secondary and tertiary. The presence of a double or triple bond is considered to affect the strength of the carbon-hydrogen bonds on the carbon sharing the double bond, and on the carbon adjacent to it. All other interactions are neglected. Double and triple carbon-carbon bonds are assigned different values.

A method for applying the scheme to homologous series containing a functional group is also described.

An extension of this scheme to include certain organic compounds of sulphur and oxygen will now be described; this work has already been published (11).

### THERMODYNAMICAL AND EMPIRICAL CONSIDERATIONS

#### Heats of Combustion, Formation and Atomization

The heat of atomization,  $Q_a$ , used here can be defined as the energy required to dissociate one mole of a compound in the gaseous state at 25°C. into its constituent atoms in their ground states at 25°C. The heat of formation is the heat change when one mole of a compound in its standard state is formed from its constituent elements in their standard states. Here the standard state is taken to be the stable form of the compound or element at 25°C. under atmospheric pressure. Of the four elements involved in the homologous series considered here, oxygen and hydrogen are diatomic gases, carbon is in the form of graphite, and sulphur is in the rhombic crystal modification in the standard state. In order to calculate heats of atomization from heats of formation it is therefore necessary to know the heat of atomization of these four elements in their standard states.

A controversy over the heat of atomization of carbon has existed for many years. Cottrell (12), in a review of this subject, states that all the direct evidence is now in accord with the value of 170 kcal. mole<sup>-1</sup>, and that there is no thoroughly established evidence in conflict with this value. There are some anomalies which remain, however, and this question cannot be said to be finally settled. The value used here is 171.7 kcal.

The heat of atomization of rhombic sulphur has not been established beyond doubt. Cottrell (12) has recently reviewed the available data from which he suggests the value of 57 kcal. mole<sup>-1</sup>. This value has been used here.

The heats of atomization of hydrogen and oxygen have been unequivocally established by spectroscopic studies. The heats of atomization of these four elements at 25°C. are as follows:

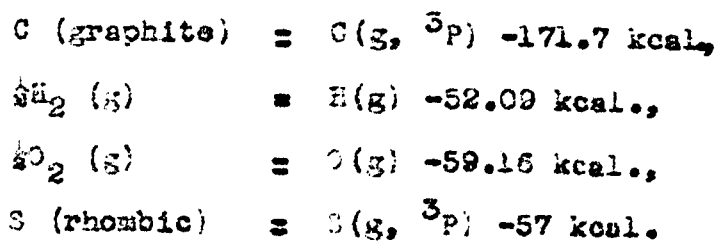

It is common practice in thermochemistry to associate a negative sign with processes which evolve heat. Here the usual procedure is reversed to avoid dealing with negative numbers. Hence heats of combustion in Part I are given with positive signs.

From the heat of atomization data given above, for the elements in their standard states, it is obvious that the heat of atomization,  $Q_a$ , is related to the heat of formation,  $Q_f$ , by equation (1).

$$Q_a = Q_f + 171.7 n_C + 52.09 n_H + 57 n_S + 59.16 n_O \quad (1)$$

Here  $n_C$ ,  $n_H$ ,  $n_S$ , and  $n_O$  are the numbers of carbon, hydrogen, sulphur and oxygen atoms per molecule respectively. If the products of combustion of compounds containing carbon, hydrogen, sulphur and oxygen are carbon dioxide, water, and rhombic sulphur, then the heat of formation is related to the heat of combustion,  $Q_c$ , by equation (2).

$$Q_f = -Q_c + 94.05 n_C + 34.16 n_H \quad (2)$$

This relationship is based upon heat of formation values for carbon dioxide and liquid water of 94.05 and 68.32 kcal. mole<sup>-1</sup> respectively (13). Substitution of equation (2) into equation (1) gives the following relationship between the heat of combustion and the heat of atomization:

$$Q_a = -Q_c + 265.75 n_C + 86.25 n_H + 59.16 n_O + 57 n_S \quad (3)$$

In view of the relationships between heats of combustion, formation, and atomization it is necessary to devise a scheme for only one of these quantities. The quantity chosen is the heat of atomization.

### The Empirical Scheme

The compounds to be treated are the alkanethiols (R-S-H), the thiaalkanes (R-S-R) and the dithiaalkanes (R-S-S-R) as well as their oxygen analogues. Bond energy contributions to the heat of atomization of the sulphur and oxygen compounds and to the heat of vaporization of the sulphur compounds are calculated.

The empirical scheme is based upon the following considerations. The contribution to the heat of atomization of all carbon-carbon, carbon-sulphur, sulphur-hydrogen, sulphur-sulphur, carbon-oxygen, oxygen-hydrogen, and oxygen-oxygen bonds is independent of the environment of the bond. There are two classes of carbon-hydrogen bonds, the first of which consists of bonds not adjacent to a sulphur or oxygen containing functional group. Contributions to the heat of atomization from these bonds, which may be primary, secondary, or tertiary, are the same as for the unsubstituted paraffins. Bonds of the second class have a sulphur or oxygen atom bound to the same carbon atom and have values different than the unsubstituted paraffins.

Bond energies for bonds of the first class have already been calculated by Laidler (10). Since this work is an extension of his scheme, Laidler's values will be used here. The three types of carbon-hydrogen bond in the paraffins are the primary, secondary, and tertiary bonds, denoted by p, s, and t respectively. The energies of these bonds (10), as well as of the carbon-carbon bond,  $c_1$ , are:

$$\begin{aligned}c_1 &= 85.40 \text{ kcal.}, & s &= 97.350 \text{ kcal.}, \\p &= 98.467 \text{ kcal.}, & t &= 96.797 \text{ kcal.}\end{aligned}$$

Bond energies of the second class are to be calculated here. There are three types of carbon-hydrogen bonds in which a sulphur atom is joined to the same carbon, as are the hydrogens. These are primary, secondary, and tertiary bonds, denoted by  $p_s$ ,  $s_s$ , and  $t_s$ , respectively. In addition there are sulphur-hydrogen bonds of energy sh, sulphur-carbon bonds of energy sc, and sulphur-sulphur bonds of energy ss present in these compounds.

The same bonds are used in obtaining bond energies for the calculation of heats of vaporization. The bond energy contributions calculated by Laidler (10) for the heats of vaporization are:

$$\begin{aligned}c_1 &= 0.00 \text{ kcal.}, & s &= 0.579 \text{ kcal.}, \\p &= 0.494 \text{ kcal.}, & t &= 0.518 \text{ kcal.}\end{aligned}$$

For the oxygen analogues of the sulphur compounds the carbon-hydrogen bonds are the primary,  $p_o$ , the secondary,  $s_o$ , and the tertiary,  $t_o$ . The carbon-oxygen bond is denoted by  $oc$ , the oxygen-hydrogen bond by  $oh$ , and the oxygen-oxygen bond by  $oo$ .

#### CALCULATIONS

##### Heats of Atomization and Vaporization of Sulphur Compounds

Heat of formation data for seventeen sulphur-containing organic compounds were assembled. From these data six quantities,  $sh$ ,  $sc$ ,  $ss$ ,  $p_s$ ,  $s_s$ , and  $t_s$  must be determined. This could have been done by selecting six of these compounds, so that each type of bond is represented at least once, writing down the bonds present in each compound, setting them equal to the heat of atomization, and solving the six resulting equations simultaneously. A better way however is to use a least squares procedure, carried out on a computer. This was done using an I. B. M. 650 computer. In this way the values in Table I were obtained.

TABLE I

Bond Strengths for Sulphur Compounds

sh = 81.90	p <sub>s</sub> = 98.14
sc = 66.36	s <sub>s</sub> = 97.63
ss = 54.46	t <sub>s</sub> = 97.14

Heats of atomization calculated from the values in Table I, along with the previously given values of  $c$ ,  $p$ ,  $s$ , and  $t$  are given in Table II, along with the bonds present in each compound, the experimental heat of formation and atomization of the compound, and reference to the experimental work.

Bond contributions to the heat of vaporization of these compounds were obtained in an analogous fashion. Table III gives the bond contributions to the heat of vaporization.

In Table IV the calculated heat of vaporization is compared to the experimental value. Reference to the experimental work for each compound is given in Table II.

#### Heats of Atomization of Oxygen Compounds

The data available for the oxygen analogues of the above sulphur compounds are not as reliable. The six bond-energy terms were evaluated by carrying out the least squares method on the computer. The results of the calculation are given in Table V.

The bonds present in each compound, the heat of formation, the experimental and calculated heat of atomization, and the reference to the experimental work are given in Table VI.

TABLE II

Sulphur Compounds: Heats of Atomization  
(kcal. mole<sup>-1</sup>)

Compound	Bonds	Q <sub>f</sub> (obs.)	Q <sub>a</sub> (obs.)	Q <sub>a</sub> (calc.)	Q (obs.) - Q (calc.)	Ref.
Ethanethiol C <sub>2</sub> H <sub>6</sub> S	sh+sc+2s <sub>g</sub> +3p+c <sub>l</sub>	11.03	724.0	724.3	-0.3	14
2-Thiapropane C <sub>2</sub> H <sub>6</sub> S	2sc+6p <sub>s</sub>	8.98	721.9	721.6	0.3	14
2,3 Dithiabutane C <sub>2</sub> H <sub>6</sub> S <sub>2</sub>	2sc+ss+6p <sub>s</sub>	5.75	775.7	776.0	-0.3	15
1-Propanethiol C <sub>3</sub> H <sub>8</sub> S	sh+sc+2s <sub>g</sub> +3p+2s+2c <sub>l</sub>	16.04	1004.9	1005.0	-0.1	16
2-Propanethiol C <sub>3</sub> H <sub>8</sub> S	sh+sc+t <sub>g</sub> +6p+2c <sub>l</sub>	18.04	1006.9	1007.0	-0.1	17
2-Thiabutane C <sub>3</sub> H <sub>8</sub> S	2sc+3p <sub>s</sub> +2s <sub>g</sub> +3p+c <sub>l</sub>	14.07	1002.9	1003.2	-0.3	18
1-Butanethiol C <sub>4</sub> H <sub>10</sub> S	sh+sc+2s <sub>g</sub> +3p+4s+3c <sub>l</sub>	20.87	1285.6	1285.7	-0.1	19,20
2-Butanethiol C <sub>4</sub> H <sub>10</sub> S	sh+sc+t <sub>g</sub> +6p+2s+3c <sub>l</sub>	22.97	1287.7	1287.7	0	19,21
2-Methyl-1-propanethiol C <sub>4</sub> H <sub>10</sub> S	sh+sc+2s <sub>g</sub> +6p+t+3c <sub>l</sub>	23.06	1287.8	1287.7	0.1	19,22
2-Methyl-2-propanethiol C <sub>4</sub> H <sub>10</sub> S	sh+sc+9p+3c <sub>l</sub>	25.99	1290.7	1290.7	0	23

TABLE II - (Cont'd)

Sulphur Compounds: Heats of Atomization

(kcal. mole<sup>-1</sup>)

Compound	Bonds	Q <sub>f</sub> (obs.)	Q <sub>a</sub> (obs.)	Q <sub>a</sub> (calc.)	Q (obs.) - Q (calc.)	Ref.
3-Thiapentane C <sub>4</sub> H <sub>10</sub> S	2sc+4s <sub>g</sub> +6p+2o <sub>l</sub>	19.77	1284.5	1284.9	-0.4	19,24
2-Thiapentane C <sub>4</sub> H <sub>10</sub> S	2sc+3p <sub>g</sub> +2s <sub>g</sub> +3p+2s+2o <sub>l</sub>	19.36	1284.1	1283.9	0.2	19,20 <sup>15</sup>
3-methyl-2-thiabutane C <sub>4</sub> H <sub>10</sub> S	2sc+3p <sub>g</sub> +t <sub>g</sub> +6p+2o <sub>l</sub>	21.43	1286.1	1285.9	0.2	19,25 <sup>15</sup>
3,4-Dithiahexane C <sub>4</sub> H <sub>10</sub> S <sub>2</sub>	2sc+ss+4s <sub>g</sub> +6p+2o <sub>l</sub>	17.42	1339.1	1339.3	-0.2	15
1-Pentanethiol C <sub>5</sub> H <sub>12</sub> S	sh+sc+2s <sub>g</sub> +3p+6s+4o <sub>l</sub>	26.29	1566.9	1566.4	0.5	26,27
4,5 Dithiaoctane C <sub>6</sub> H <sub>14</sub> S <sub>2</sub>	2sc+ss+4s <sub>g</sub> +6p+4s+4o <sub>l</sub>	27.77	1901.2	1900.7	0.5	15
5-Thianonane C <sub>6</sub> H <sub>18</sub> S	2sc+4s <sub>g</sub> +6p+3s+6o <sub>l</sub>	40.3#	2408.5	2407.7	0.8	27

#T = 20°C; this compound was not included in the least-squares calculation.

TABLE III

Bond Contributions to the Heat of Vaporization  
of Sulphur Compounds

sh = 2.209	p <sub>s</sub> = 0.877
sc = 0.735	s <sub>s</sub> = 1.002
ss = 2.349	t <sub>s</sub> = 1.117

TABLE IV

Heats of Vaporization of Sulphur Compounds

(kcal mole<sup>-1</sup>)

	$\Delta H_v$ (obs.)	$\Delta H_v$ (calc.)	$\Delta H_v$ (obs.) - $\Delta H_v$ (calc.)
Ethanethiol	6.58	6.68	-0.10
2-Thiapropane	6.66	6.73	-0.07
2,3-Dithiabutane	9.18	9.08	0.10
1-Propanethiol	7.65	7.59	0.06
2-Propanethiol	7.08	7.03	0.05
2-Thiabutane	7.61	7.59	0.02
1-Butanethiol	8.74	8.75	-0.01
2-Butanethiol	8.13	8.18	-0.05
2-Methyl-1-propanethiol	8.30	8.43	-0.13
2-Methyl-2-propanethiol	7.39	7.39	0.00
3-Thiapentane	8.57	8.44	0.13
2-Thiapentane	8.67	8.74	-0.07
3-Methyl-2-thiabutane	8.18	8.18	0.00
3,4-Dithiahexane	10.86	10.79	0.07
1-Pentanethiol	9.83	9.90	-0.07
4,5-Dithiooctane	12.94	13.11	-0.17
5-Thianonane	12.4	13.1	-0.7

TABLE V

The Bond Strengths for Oxygen Compounds

oh = 109.79	p <sub>o</sub> = 96.24
oc = 90.99	s <sub>o</sub> = 95.42
oo = 47.72	t <sub>o</sub> = 94.54

TABLE VI

Oxygen Compounds: Heats of Atomization(kcal. mole<sup>-1</sup>)

Compound	Bonds	Q <sub>f</sub> (obs.)	Q <sub>a</sub> (obs.)	Q <sub>a</sub> (calc.)	Q (obs.) - Q (calc.)	Ref.
Ethanol C <sub>2</sub> H <sub>6</sub> O	oh+oo+2s <sub>o</sub> +3p+o <sub>1</sub>	56.24	771.3	772.4	-1.1	28
Methyl ether C <sub>2</sub> H <sub>6</sub> O	2oo+6p <sub>o</sub>	44.3	759.4	759.4	0.0	28
2-Propanol C <sub>3</sub> H <sub>8</sub> O	oh+oo+t <sub>o</sub> +6p+2o <sub>1</sub>	65.96 <sup>#</sup>	1056.9	1056.9	0.0	29
1-Butanol C <sub>4</sub> H <sub>10</sub> O	oh+oo+2s <sub>o</sub> +3p+4s+3o <sub>1</sub>	67.84 <sup>#</sup>	1334.7	1333.8	0.9	30
2-Methyl-2-propanol C <sub>4</sub> H <sub>10</sub> O	oh+oo+9p+3o <sub>1</sub>	77.0	1343.9	1343.2	0.7	31
Diethyl peroxide C <sub>4</sub> H <sub>10</sub> O <sub>2</sub>	2oo+oo+4s <sub>o</sub> +6sp+2o <sub>1</sub>	47.3	1373.3	1373.0	0.3	32
Diisopropyl ether C <sub>6</sub> H <sub>14</sub> O	2oo+2t <sub>o</sub> +12p+4o <sub>1</sub>	75.68 <sup>#</sup>	1894.3	1894.3	0.0	28
2-Ethyl-1-hexanol C <sub>8</sub> H <sub>18</sub> O	oh+oo+2s <sub>o</sub> +6p+8s+t+7o <sub>1</sub>	87.43 <sup>#</sup>	2457.8	2458.2	-0.4	30
Di(tert-butyl)peroxide C <sub>8</sub> H <sub>18</sub> O <sub>2</sub>	2oo+oo+18p+6o <sub>1</sub>	84.7	2514.2	2514.6	-0.4	31

# ΔH<sub>f</sub> (l, 25°C) was given in the reference; ΔH<sub>f</sub> (g, 25°C) was calculated from ΔH<sub>f</sub> (l) and vapor pressure data (28).

#ΔH<sub>f</sub> (l, 25°C) was given in the reference; ΔH<sub>f</sub> (g, 25°C) was calculated from ΔH<sub>f</sub> (l) and ΔH<sub>v</sub> as calculated by the method given in Part I. (10).

Heats of Formation and Combustion

From the bond energy contributions to the heat of atomization it is possible to calculate bond energy contributions to the heats of formation and combustion. Let us first consider the problem of calculating bond energies for the heat of formation.

The heat of formation is related to the heat of atomization by equation (1).

$$Q_f = Q_a - 171.7 n_C - 52.09 n_H - 59.16 n_O - 57 n_S \quad (1).$$

For a general compound containing carbon, hydrogen, oxygen, and sulphur, the heat of atomization can be calculated using the bond energy terms already obtained. If  $C_1$  is the number of  $c_1$  bonds,  $P$  the number of  $p$  bonds,  $S_o$  the number of  $s_o$  bonds, and so forth, then we can write

$$\begin{aligned} Q_a = & 85.40 C_1 + 98.47 P + 97.65 S + 98.60 T + 81.90 SR \\ & + 66.36 SC + 54.46 SS + 98.14 P_s + 97.63 S_s + 97.14 T_s \\ & + 109.79 OH + 90.99 OC + 47.72 OO + 96.24 P_o \\ & + 95.42 S_o + 94.54 T_o. \quad (4). \end{aligned}$$

In order to obtain an expression for  $Q_f$  containing only the number of bonds present in the compound, we must relate the number of bonds to the number of atoms. These

relationships, together with equation (4) can then be substituted into equation (1) to give an expression for  $Q_p$ .

Each carbon-hydrogen bond accounts for  $\frac{1}{4}$  of a carbon atom (since all the carbons here are tetrahedral), as does each OC and each SC bond. Each carbon-carbon bond accounts for  $\frac{1}{2}$  of a carbon atom;  $\frac{1}{2}$  of each of the carbons it joins. Hence, we can say that

$$n_C = \frac{1}{4} (P+S+T+P_s+S_s+T_s+P_o+S_o+T_o+CC+SC) + \frac{1}{2}C_1. \quad (5).$$

Each bond involving a hydrogen atom accounts for one hydrogen atom.

$$n_H = P+S+T+P_s+S_s+T_s+P_o+S_o+T_o+SH+OH. \quad (6).$$

Each SH bond and each SC bond accounts for  $\frac{1}{2}$  of a sulphur atom, and each S-S bond accounts for one sulphur atom, giving:

$$n_S = \frac{1}{2} (SH+SC) + SS. \quad (7).$$

Analogously, for the oxygen bonds,

$$n_o = \frac{1}{2} (OH + OC) + OO. \quad (8).$$

Substituting equations (4) to (8) inclusive into equation (1), and collecting terms gives

$$\begin{aligned} Q_f = & - 0.45 C_1 + 3.45P + 2.63 S + 1.78 T + 3.12P_s + 2.61 S_c \\ & + 2.12 T_s + 1.22 P_o + 0.40 S_o - 0.48 T_o + 1.31 SH \\ & - 5.07 SC - 2.54 SS + 28.12 OH + 18.48 OC \\ & - 11.44 OO. \quad (9). \end{aligned}$$

The coefficients of equation (9) are the bond-energy contributions to the heat of formation for a compound containing carbon, hydrogen, oxygen, and sulphur when that compound is in the vapor state at 25° C. The addition of these bond-energy contributions to the corresponding contributions to the heat of vaporization yields bond energies permitting the calculation of the heat of formation in the liquid state. These bond energies are given in Table VII.

The calculation of bond-energy contributions to the heat of combustion from those contributing to the heat of atomization proceeds in an analogous manner. The heat of atomization is related to the heat of combustion by

equation (3), which upon rearrangement gives

$$Q_c = -Q_a + 265.75 n_C + 86.25 n_H + 59.16 n_O + 57 n_S. \quad (10).$$

Substituting equations (4) to (8) inclusive into equation (10) gives, after collecting terms,

$$\begin{aligned} Q_c = & 47.48 C_1 + 54.22 P + 55.04 S + 55.89 T + 54.55 P_s \\ & + 55.06 S_s + 55.55 T_s + 56.45 P_o + 57.27 S_o \\ & + 58.15 T_o + 32.85 SH + 28.58 SC + 2.34 SS \\ & + 6.04 OH + 5.03 OC + 11.44 OO. \end{aligned} \quad (11).$$

The coefficients of equation (11) are the bond energy contributions to the heat of combustion of a compound in the vapor state at 25° C. In order to obtain the bond contributions for a compound in the liquid state at 25° C., the bond contributions to the heat of vaporization must be subtracted from the coefficients of equation (11). These bond contributions are given in Table VII. It will be noted that bond contributions for oxygen-containing compounds in the liquid state are not given. This is so because the experimental data available do not permit bond contributions to the heat of vaporization of oxygen-containing compounds to be calculated with the desired accuracy.

TABLE VII

Bond Contributions to Heats of Atomization,  
Formation, and Combustion of Sulphur- and Oxygen-containing  
Liquids and Gases

Bond Symbol	$Q_a$		$Q_f$		$Q_c$	
	Gas	Liquid	Gas	Liquid	Gas	Liquid
C-C $c_l$	85.40	85.40	-0.45	-0.45	47.48	47.48
C-E p	98.47	98.96	3.45	3.94	54.22	53.73
C-H s	97.65	98.23	2.63	3.21	55.04	54.46
C-E t	96.80	97.32	1.78	2.30	55.89	55.37
S-H sh	81.90	84.11	1.31	3.52	32.85	30.64
S-C sc	66.35	67.10	-5.07	-4.33	28.58	27.84
S-S ss	54.45	56.81	-2.34	0.01	2.34	0
C-H $p_s$	98.14	99.02	3.12	4.00	54.55	53.67
C-H $s_s$	97.63	98.63	2.61	3.61	55.06	54.06
C-H $t_s$	97.14	98.26	2.12	3.24	55.55	54.43
O-H oh	109.79		28.12		6.04	
O-C oc	90.99		18.48		5.03	
O-O oo	47.72		-11.44		11.44	
C-H $p_o$	96.24		1.22		56.45	
C-H $s_o$	95.42		0.40		57.27	
C-H $t_o$	94.54		-0.48		58.15	

### Discussion

The success of the calculations is tested by comparing calculated heats of atomization to heats of atomization determined experimentally. This has been done, with the results presented in Table II for the sulphur compounds and in Table VI for the oxygen compounds. The average absolute difference between the experimental and calculated quantities is 0.3 kcal. mole<sup>-1</sup> for the sulphur and 0.6 kcal. mole<sup>-1</sup> for the oxygen compounds.

Since the publication of this work (11) a modern determination of the heat of combustion of the four butyl alcohols has been made by Skinner and Snelson (33). It is of interest to compare their experimental heats of formation of the four butyl alcohols with the heats of formation calculated using the bond energies in Table VII. The experimental results, with the calculated heat of formation in brackets are as follows:

n-butyl alcohol (g)	-66.1 ± 0.35	(-66.9),
i-butyl alcohol (g)	-67.9 ± 0.35	(-68.5),
s-butyl alcohol (g)	-70.1 ± 0.35	(-70.7),
t-butyl alcohol (g)	-74.9 ± 0.35	(-76.3).

The differences between the calculated and experimental heats of formation are appreciable. These differences point to the need for more good experimental data on homologous series containing functional groups.

PART II

HEATS OF REACTION

INTRODUCTION

In recent years polyurethanes have played an increasingly important role in modern plastics technology. Polyurethanes are formed by the reaction of a diisocyanate with a dihydroxy alcohol, usually a polyol. The reaction of 2,4-tolylene diisocyanate with ethylene glycol is an example of polyurethane formation.

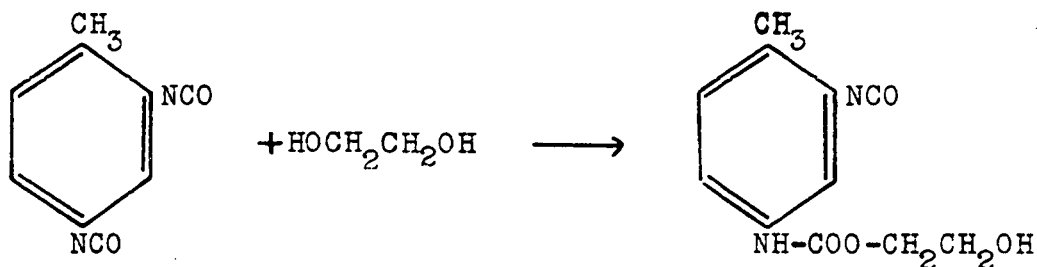

The difunctional product of this reaction will continue to react, ultimately giving long polyurethane chains.

A search of the literature reveals that there is a lack of thermodynamic data concerning reactions of this type, as well as data concerning the isocyanate reactants and the urethane products. In view of our nearly complete ignorance of the thermochemistry of these reactions it was

decided to study the heats of reaction between some simple alcohols and isocyanates, rather than investigate the more complicated reactions giving rise to polyurethanes. The heats of reaction measured were those between each of normal, iso, and secondary butyl alcohol, and each of phenyl, the three tolyl isocyanates, and 2,4-tolylene diisocyanate.

Since heats of reaction are readily calculated from heats of formation it was necessary to survey the literature not only for heat of reaction data, but also for data concerning the heat of formation of the isocyanates, alcohols, and urethanes involved. The only data available concerning isocyanates are those due to Lemoult (34) who, in 1899, measured the heat of combustion of methyl and ethyl isocyanate. In the case of ethyl isocyanate his final result, obtained by averaging three determinations, was 424.5 kcal mole<sup>-1</sup>. Lemoult does not assign an experimental error to his work, nor does he define the calorie he used. No analysis of the combustion products is reported. In view of these uncertainties, no attempt was made to convert the reported value into defined calories.

No heat of formation data are available for any urethane of the type R-NH-CO-O-R', although Kharasch (4) gives the heat of formation of urethane itself. In addition, the heat of formation of a few di-R-substituted urethanes are given by Schmidt (35). However, none of these data are of importance to the present work.

Recently new data for the heat of formation of the four butyl alcohols have been published by Skinner and Snelson (33). The results they obtained were given in Part I.

### EXPERIMENTAL

#### The Calorimeter

The heats of reaction were measured with a differential microcalorimeter of the Tian-Calvet type (36). In essence the calorimeter consists of two reaction cells, each surrounded by a thermopile which has one set of junctions in thermal contact with a reaction cell, and the other set in contact with an isothermal heat sink, common to both cells. The thermopiles are connected in electrical opposition to each other. Hence a voltage will appear in the thermopile circuit only if there is a temperature difference between the cells. If the temperature of the heat sink is changed, there will be no voltage in the thermopile circuit.

A schematic diagram of the microcalorimeter used in this work appears in Figure 1. The heat sink, A, consists of a cylindrical sixty-pound block of aluminium. There are two holes, B, in the top of the block, the centers of which lie on a diameter of the block, and at an equal distance from its center. A silver thimble, C, is suspended in each hole by means of a plastic support ring, E. The thermopiles, D, are installed in the space between the aluminium block

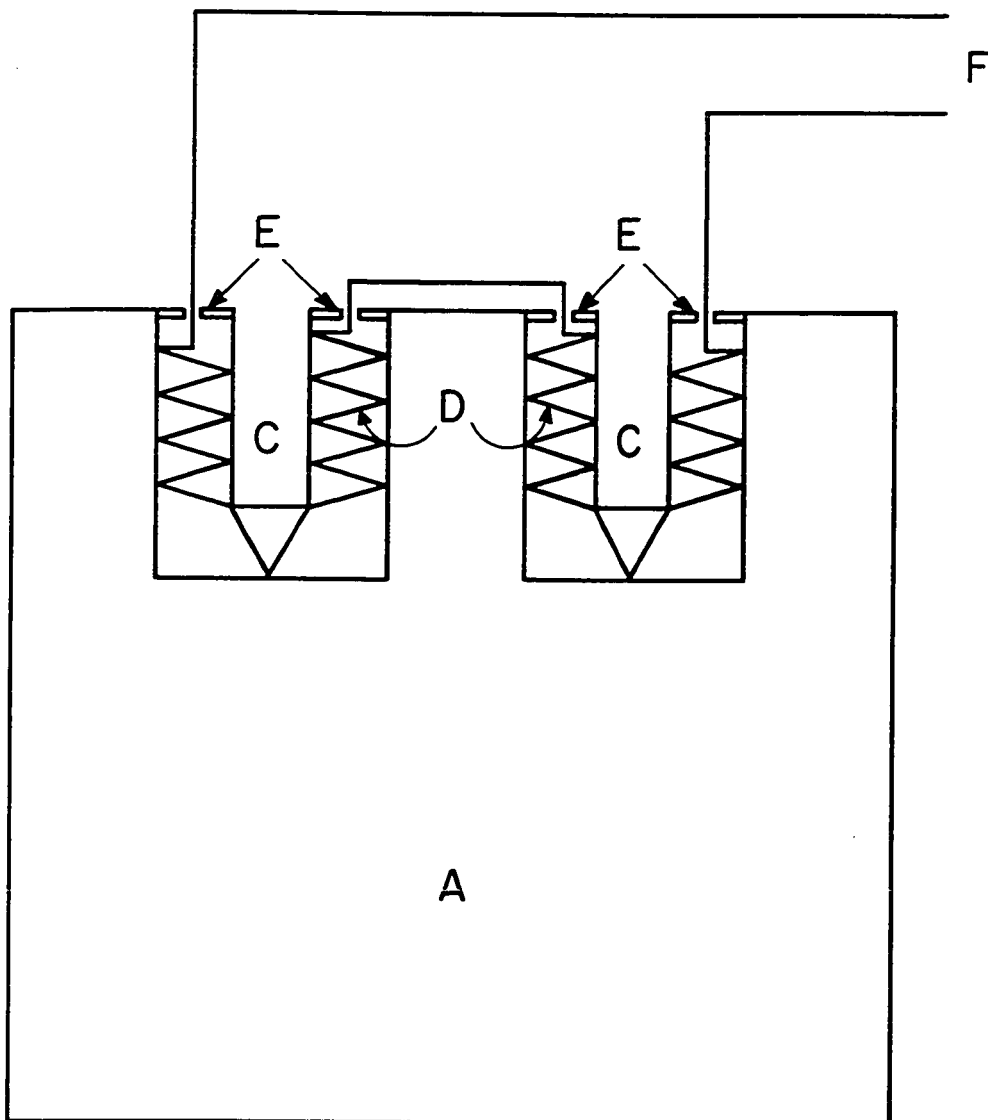

Figure 1 Schematic diagram of the calorimeter.

and the silver thimbles. Each thermopile consists of 16 iron-constantan junctions. The junctions are attached to the thimbles and the block by Glyptol cement, which insulates the junctions electrically from the block and the thimble, but which gives reasonably good thermal contact. The reaction vessels, to be described later, fit snugly into the silver thimbles.

In order to protect the aluminium block and its fittings from external temperature fluctuations it is surrounded by five concentric aluminium cans. The space between the outer can and the first inside can is packed with cotton. There is dead air space between all the other cans. Access to the silver thimbles is provided through long bakelite tubes which lead from the outside of the apparatus through the insulating cans to the silver thimbles.

The thermopiles are connected to an electronic amplifier which, in turn, is connected to a recording potentiometer. This arrangement gives a record of the amplified thermopile E. M. F. as a function of time. An electronic integrator is also connected to the amplifier, so that a direct measure of the area under the voltage-time curve can be obtained. It will be shown later that the difference between the heat produced in the two calorimeter cells is directly proportional to this area.

The amplification and integration circuits have been described by Attree, Ladd, Cushing, and Pieroni (37).

The basic amplifier circuit is shown in Figure 2a. The output from the thermopiles is fed into a modified Liston-Becker Model 14 d.c. - breaker amplifier. All-over feedback has been incorporated to improve the stability and to increase the impedance of the circuit. The output from the low pass filter, after passing through a calibrating resistor, is used to drive a Leeds and Northrup recording potentiometer.

The integrator circuit consists of a resistance-capacitance network connected to a high gain, high impedance direct current amplifier. The amplifier used is a Cary Model 31 vibrating reed electrometer, manufactured by Applied Physics Corporation. A schematic diagram of the basic circuit is given in Figure 2b. It can be shown (38) for a circuit of this type that

$$e_o = \frac{1}{RC} \int_0^t e_i dt$$

where  $e_i$  is the input and  $e_o$  the output voltage. The input voltage is the amplified thermobile voltage. The output voltage,  $e_o$ , is used to drive a Leeds and Northrup recording potentiometer, so that a curve of area versus time is obtained.

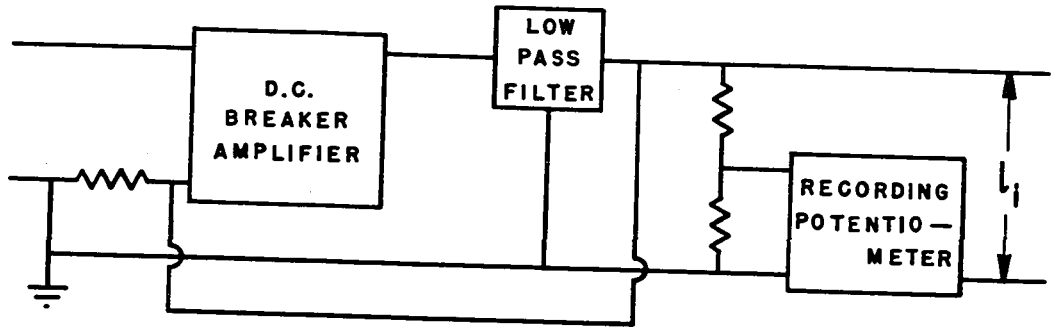

Figure 2a Schematic diagram of the basic amplifier circuit.

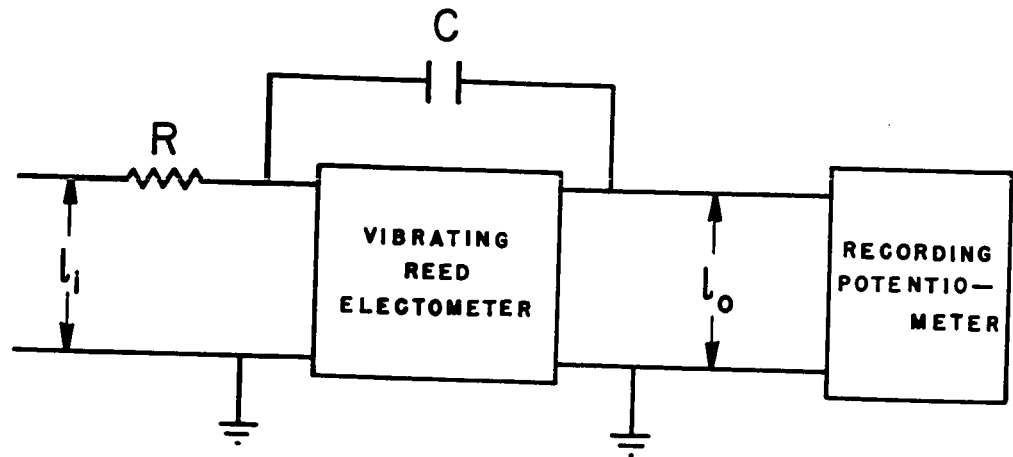

Figure 2b Schematic diagram of the basic integrator circuit.

The calorimeter is placed in a small cabin, the temperature of which is kept at  $25.0 \pm 0.2^{\circ}\text{C}$ . This is done to protect it from large random temperature changes, and also to thermostat the calorimeter at  $25^{\circ}\text{C}$ . The cabin temperature is controlled by bimetallic strip thermostats, acting through mercury relays. The relays in turn activate either a heating element in the cabin, or a pump which circulates cold antifreeze through a coil in the cabin, depending upon whether the cabin is to be warmed or cooled.

#### The Reaction Cell Assembly

The reaction cell is capable of containing both reactants until temperature equilibrium with the calorimeter has been attained. It provides a means of bringing the reactants together at the proper time, and also a method whereby the reacting mixture can be stirred gently. A schematic diagram of the reaction cell is given in Figure 3.

The reaction cell itself is made of glass, on to which a thin layer of copper has been plated to improve its heat conductivity. One of the reactants is put directly into this cell. The other reactant is put into a capsule which consists mainly of a piece of stainless steel tubing. The ends of the tubing are covered with small pieces of aluminium foil, held tightly in place by teflon sleeves. In addition, the upper teflon sleeve fits snugly over glass

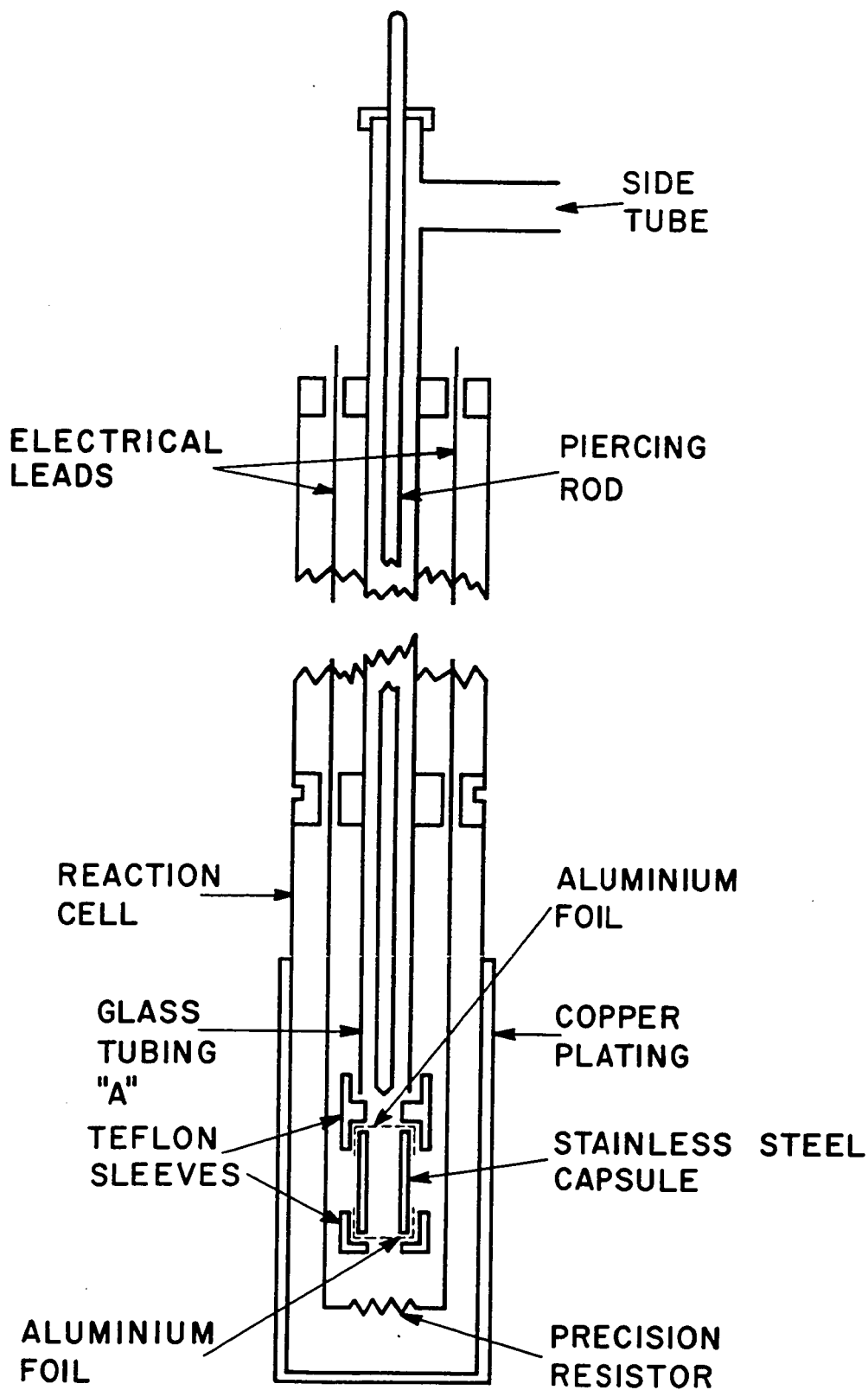

Figure 3 The reaction cell assembly.

tubing "A" (see Figure 3), so that the capsule can be suspended in the reaction cell. The piercing rod, used to puncture the ends of the capsule at the proper time and thereby bring the reactants together, is held within this piece of glass tubing. At the upper end of the assembly the piercing rod passes through a rubber policeman which holds it firmly in place and, as well, closes the reaction cell off from the atmosphere.

The reacting mixture in the cell can be stirred in two ways. The simplest method is to attach a rubber squeeze bulb to the side tube, and squeeze it, thereby drawing the reacting mixture into glass tube "A" through the now pierced capsule. Stirring in this way however is not generally satisfactory because it is not reproducible, and because the reacting mixture must be stirred for long periods of time. Instead, the following method was used. A glass U-tube was partially filled with vacuum pump oil. One side of the U-tube was connected to the side tube of the reaction cell assembly by a short piece of rubber tubing. A small piston, made of glass with a snugly fitting teflon disk on the end was placed in the other arm of the U-tube. This piston was driven by a geared down electric motor at a rate of about 60 cycles per minute. Stirring by this method is gentle and reproducible.

The reaction cell contains a calibrating resistor, placed beneath the stainless steel capsule. It is held in

place by its electrical leads. These leads, of fine copper wire, extend out the top of the cell assembly, so that they can be connected to a current source.

The Relationship Between the Heat Liberated in the Calorimeter and the Integral of the Voltage-Time Curve.

The treatment to be given is a modification of that given by Calvet and Prat (36).

Consider the case of a reaction taking place in one cell of the calorimeter, which increases the temperature of that cell from  $T_0$ , the temperature of the heat sink, to some temperature  $T$ , at time  $t$ . Let

$$\Delta T = (T - T_0).$$

The rate of heat loss from the reaction chamber to the heat sink,  $\frac{dq}{dt}$ , is proportional to  $T$ . If we assume that the reaction cell cools in accordance with Newton's Law of Cooling, then

$$\frac{dq}{dt} = h\Delta T, \quad (12).$$

where  $h$  is a constant.

The E. M. F. produced in the thermopile circuit is also proportional to the temperature increase  $T$ , so that

$$E = k\Delta T, \quad (13).$$

where  $k$  is another constant. Substituting equation (13) into equation (12) yields

$$\frac{dq}{dt} = \frac{h}{k} E. \quad (14).$$

Separating the variables, and integrating over all time gives

$$Q = \frac{h}{k} \int_0^{\infty} E dt \quad (15).$$

where  $Q$  is the total heat liberated in the reaction cell.

Let us write  $h/k = A$ ; equation (15) now becomes

$$Q = A \int_0^{\infty} E dt.$$

In practice  $A$  is determined by calibration of the apparatus.

#### Calibration of the Calorimeter

The calorimeter was calibrated by measuring the integral of the voltage-time curve for various amounts of heat liberated in the reaction cell by electrical heating. The electrical heat was produced by passing a known current through a measured resistance in the reaction cell for a definite period of time. The heat produced, in joules, is then obtained from  $J = I^2 R t$ . The calories used throughout this thesis are defined calories; joules were converted to

defined calories by dividing by 4.1840. The integral of the voltage-time curve was obtained directly from the integrating circuit chart.

The current flowing through the calibrating resistor was determined by measuring the voltage across a known resistance in series with the calibrating resistor. The voltage over the series resistor was measured on a Tinsley potentiometer, Type 3589-R. The series resistance and the calibrating resistance were both precision resistors, the value of which did not change over long periods of time, nor with small temperature fluctuations. These resistors were periodically checked on a Tinsley Wheatstone Bridge, Type 4970. The current of about 0.04 amperes used in the calibrating circuit was drawn from a 200 ampere-hour lead accumulator; it remained essentially constant during each calibration. The standard cell in the potentiometer circuit was checked by comparing it to a cell which was known to be good.

Before proceeding with a calibration of the apparatus, it was necessary to be sure that equal amounts of heat, introduced into each reaction cell, would give a net area of zero under the voltage-time curve. This was done by dissolving equal amounts of N-phenyl-n-butyl urethane in equal amounts of n-butyl alcohol. Within the experimental error, the net integral was found to be zero.

In order to be sure that the calibration procedure was correct, the heat of a known reaction was measured. The reaction chosen was the solution of anhydrous lithium sulphate crystals in water. Lithium sulphate monohydrate was heated to redness in a platinum dish and cooled in a desiccator. It was then pulverized, and 0.2775 grams were weighed into a stainless steel capsule. In the reaction cell it was dissolved in 10 mls. of distilled water. The reaction is:



The measured heat of reaction for this process was  $6.54 \pm 0.10$  kcal. mole<sup>-1</sup>, compared with the literature value (13,39) of 6.61 kcal. mole<sup>-1</sup>. Since these two figures are in agreement, within the experimental error, the electrical calibration process was deemed to be satisfactory.

#### Purity of Materials

The normal and iso butyl alcohols used in the experiments were Fisher Certified Reagent chemicals. The secondary butyl alcohol was a Fisher "Highest Purity" reagent. The alcohols were dried by refluxing 1.5 liters of alcohol over 20 grams of freshly ignited calcium oxide for four hours. The alcohol was then distilled off through a fractionating column, about 40 cm long, and packed with 1 cm lengths of 4 mm glass tubing. The fractionating rate was such that about 30 drops of liquid were returned to the distilling

flask for every drop that entered the receiver. Only the alcohol distilling at the boiling point of the alcohol was collected. For normal, iso, and secondary butyl alcohols, the boiling points are  $117.7^{\circ}$ ,  $108.4^{\circ}$ , and  $99.5^{\circ}$  C. respectively. These alcohols can be dried by fractionation, as the azeotropes formed with water by normal, iso, and secondary butyl alcohol boil  $26^{\circ}$ ,  $19^{\circ}$ , and  $11^{\circ}$  lower respectively than does the pure alcohol (40). Usually it was necessary to discard the first 400 ml of distillate, and 500 ml of alcohol were always left in the distilling flask. The alcohols were stored in a desiccator over silica gel until used.

Each new batch of alcohol was tested for the presence of water by the method given by Dyer, Taylor, Mason, and Samson (41). One or two drops of phenyl isocyanate were added to ten mls. of the alcohol. If water is present in the alcohol, then a precipitate of the very insoluble  $N,N'$ -diphenyl urea will form. If no such precipitate formed, the alcohol was deemed to be suitable for the experiments. The insolubility of  $N,N'$ -diphenyl urea in each of the three alcohols was checked by putting one or two small crystals of this material into 50 mls. of each alcohol. The crystals did not dissolve after 24 hours. The phenyl and mono tolyl isocyanates used were manufactured by Eastman Organic Chemicals. Each isocyanate was distilled, under vacuum, and only the

middle portion of the distillate was retained. Each isocyanate was again distilled immediately prior to use. The distillation temperatures, and pressures, are given in Table VIII for these isocyanates.

The 2,4-tolylene diisocyanate used was obtained from the Canadian Armament Research and Development Establishment. It was treated as were the other isocyanates. It distilled at 165°C. under a pressure of about 50 mm of mercury.

The normal, iso, and secondary butyl urethanes of phenyl isocyanate were prepared by causing dry alcohol, in 10% excess, to react with freshly distilled phenyl isocyanate. After the reaction mixture had cooled the product was dissolved in petroleum ether and filtered hot. The solution was cooled in an ice-water mixture and the product filtered off. It was recrystallized once more from petroleum ether, sucked dry, and then warmed at 80°C. to drive off the last of the petroleum ether. The melting points of the urethanes, and the accepted melting points (42) are given in Table IX.

The urethanes of o-tolyl isocyanate were prepared by reacting an excess of alcohol with o-tolyl isocyanate. It was necessary to catalyse the reaction with ferric acetylacetonate, and to warm the solution to get the reaction started. Several recrystallizations were necessary to remove all traces of the catalyst. The products were sucked dry and warmed in an oven at 80°C. to drive off the last traces

TABLE VIII

Boiling Points and Pressures of Isocyanates

<u>Isocyanate</u>	<u>Boiling Point (°C)</u>	<u>Pressure (mm of Hg)</u>
Phenyl	46°	5
o-tolyl	57°	10
m-tolyl	62°	5
p-tolyl	66°	10

TABLE IX

N-Phenyl Urethane Melting Points

<u>Urethane</u>	<u>Melting Point</u>	<u>Literature Melting Point</u>
<u>N</u> -phenyl-n-butyl	57.5°C.	57°C.
<u>N</u> -phenyl-i-butyl	85.5 - 86°C.	86°C.
<u>N</u> -phenyl-s-butyl	64 - 65 °C.	65°C.

of petroleum ether. Only N-o-tolyl-n-butyl urethane is listed in Beilstein (42). A melting point of 45.5°C. is reported; the melting point of the prepared urethane was 45.5 to 46°C. The melting points of N-o-tolyl-i-butyl and N-o-tolyl-s-butyl urethanes are 41 to 42°C. and 42.5 to 43°C. respectively. A carbon-hydrogen analysis of these compounds was carried out. The theoretical percentages are, for carbon 69.52% and for hydrogen, 8.27%. The results obtained were 70.05% and 8.27% for N-o-tolyl-i-butyl urethane, 69.58% and 8.18% for N-o-tolyl-s-butyl urethane.

The urethanes of m-tolyl isocyanate were prepared in the usual way, without a catalyst. Warming was necessary to start the reaction. The product was purified by vacuum distillation, only the middle fraction being collected. This fraction was again distilled, and again only the middle portion collected. These urethanes are liquids at room temperature. The results of the carbon-hydrogen analysis are given in Table X, along with the distillation temperature and pressure.

The normal and iso butyl urethanes of p-tolyl isocyanate were prepared in the usual way. The melting point of N-p-tolyl-n-butyl urethane is reported, in Beilstein (42), to be 63°C. The recrystallized product melted at this temperature. N-p-tolyl-i-butyl urethane, melting at 52.5° to 53°C., analysed to 70.01% carbon and 8.25% hydrogen. The theoretical percentages of carbon and hydrogen are 69.56%

TABLE X

N-m-tolyl urethanes: Boiling Points and Analytical Results

<u>Urethane</u>	<u>% C</u>	<u>% H</u>	<u>Boiling Point</u>	<u>Pressure</u>
N-m-tolyl-n-butyl	69.75%	8.61%	185°C.	8 mm
N-m-tolyl-i-butyl	69.47%	8.27%	183°C.	15 mm
N-m-tolyl-s-butyl	69.53%	8.67%	179°C.	20 mm
Theoretical composition	69.52%	8.27%		

and 8.27% respectively. In order to prevent the formation of a disubstituted urea, the formation of N-p-tolyl-s-butyl urethane was carried out in a large excess of s-butyl alcohol. The excess alcohol was removed by vacuum distillation, and the product recrystallized from petroleum ether. The elemental analysis revealed 69.89% carbon and 7.95% hydrogen, compared to calculated percentages of 69.56 and 8.27 respectively.

The diurethanes of 2,4-tolylene diisocyanate were made in the usual way, with recrystallizations from petroleum ether. They were sucked dry, and warmed in an oven at 80°C. The results of the carbon-hydrogen analysis, and the melting points are given in Table XI.

Di-n-butyl amine, used in the analysis of isocyanate groups, was prepared by drying over potassium hydroxide pellets for three days, with occasional shaking. It was then decanted and fractionated. The middle fraction, distilling at 158-160°C., was retained. It was stored in a desiccator in a dark cupboard.

Toluene was dried over calcium oxide and fractionated. The material distilling at the literature boiling point of 110.6°C. was collected.

The hydrochloric acid was C. P. reagent, manufactured by Canadian Industries Limited. It was used without purification.

TABLE XI

Melting Points and Analytical Results  
for N,N'-2,4-tolylene Diisocyanate Urethanes

---

<u>Diurethane</u>	<u>% C</u>	<u>% H</u>	<u>Melting Point</u>
<u>N,N'</u> -2,4-tolylene di-n-butyl	63.56	7.94	79°C.
<u>N,N'</u> -2,4-tolylene di-i-butyl	63.07	7.90	122-123°C.
<u>N,N'</u> -2,4-tolylene di-s-butyl	63.67	7.95	90-91°C.
Theoretical composition	63.3	8.1	

### Experimental Procedure

The experimental procedure used to measure the heat of reaction was the same for every reaction. As an example, let us consider the formation of N-phenyl-n-butyl urethane from n-butyl alcohol and phenyl isocyanate. The procedure was as follows.

A stainless steel capsule, one end of which was covered with a piece of aluminium foil, was weighed, packed with N-phenyl-n-butyl urethane, and reweighed. The other end was covered with a piece of aluminium foil and then the loaded capsule was attached to the end of glass tube "A", (Figure 3), which protrudes into the reaction cell. The volume of phenyl isocyanate necessary to produce this amount of urethane was calculated and the required amount loaded into a tared second capsule. This capsule was closed with a piece of aluminium foil and again weighed. The capsule of isocyanate was then attached to glass tube "A", of the second cell assembly. Ten ml of n-butyl alcohol were pipetted into each reaction cell, and the cells were fitted to the reaction cell assembly, over the capsules containing isocyanate in one case, and urethane in the other. The two assemblies were then loaded into the calorimeter, and allowed to equilibrate overnight.

The following morning the charts on the amplifier and the integrator were started, and the amplifier and integrator controls set. The aluminium foil end pieces of

the capsules were punctured by means of the piercing rod, and the stirring motor turned on. The stirring motor was allowed to run for thirty minutes. When the reaction was complete, as indicated by zero voltage in the thermopile circuit, the heat of the chemical reaction was estimated; without removing the cells from the microcalorimeter, a calibration was carried out, according to the method previously described. At the conclusion of the calibration run, the now known heat due to the chemical reaction was used to calculate the heat of the reaction  $\Delta H_r$ , in kcal. mole<sup>-1</sup>.

$$\Delta H_r = \frac{\text{molecular weight of phenyl isocyanate}}{\text{weight of phenyl isocyanate}} \times \text{heat due to the chemical reaction.}$$

Each reaction was measured at least three times; more measurements were made if the first determinations were not entirely satisfactory. The final heat of reaction is an average of the experimental values.

There is a tendency for reactions between isocyanates and secondary alcohols to yield symmetrically substituted urea, as well as urethane. Tertiary alcohol reactions exhibit this feature quite strongly. For this reason it was necessary to analyse the product of each reaction in order to be certain that the heat of reaction measured was that due to the formation of urethane. This was done in the following way: the reaction mixture was examined for the presence of

insoluble crystals, which, if present, would probably indicate a symmetrically substituted urea. By distilling off the excess alcohol under vacuum, the solid product was obtained. The infra-red spectrum of the product was compared to the known infra-red spectrum of the expected urethane obtained from the previously prepared urethane. Only in the case of the reaction between p-tolyl isocyanate and s-butyl alcohol was there a detectable amount of other product. This material was probably N,N'-di-p-tolyl urea.

#### EXPERIMENTAL RESULTS

In the case of certain reactions a catalyst was used to shorten the reaction time and decrease the experimental error due to drift in the electronic components of the calorimeter over long periods of time. The reactions studied in the presence of a catalyst are clearly marked in the tables. In order to be certain that the addition of a catalyst did not effect the measured heat of reaction, certain reactions were measured with and without a catalyst. As one would expect, there was no change in the heat of reaction upon the addition of a catalyst. The catalysts used were either ferric acetylacetonate or dimethylcetyl amine.

It will be noticed that the heats of reaction involving m-tolyl isocyanates (Table XIV) are several kcal.

less than those for the other monoisocyanates. This is because N-m-tolyl-n-butyl, N-m-tolyl-i-butyl, and N-m-tolyl-s-butyl urethanes are in the liquid state at 25°C.

The experimental results are presented in Tables XII to XVI. For each reaction studied, the results of several measurements are given. The weight of isocyanate, the heat observed, and the calculated heat of reaction per mole are given for each run. The mean heat of reaction is also given in each case. In every case the tabulated weight of isocyanate was introduced into ten mls. of the appropriate alcohol. The final state of the reaction product was a solution of the urethane in alcohol. For the sake of convenience the data are summarized in Table XVII.

TABLE XII

The Heat of Phenyl Isoocyanate Reactions at 25°C.

<u>n-Butyl Alcohol</u>		<u>i-Butyl Alcohol</u>		<u>s-Butyl Alcohol</u>	
Weight Phenyl iso-cyanate (gm)	Heat measured cal. koal.mole <sup>-1</sup>	Weight Phenyl iso-cyanate (gm)	Heat measured cal. koal.mole <sup>-1</sup>	Weight Phenyl iso-cyanate (gm)	Heat measured cal. koal.mole <sup>-1</sup>
0.1305	27.36	0.1292	26.17	0.1204	23.72
	24.97 <sup>#</sup>		24.13		23.47
0.1259	26.50	0.1264	25.52	0.1174	23.02
	25.07 <sup>#</sup>		24.05		23.36
0.1449	30.45	0.1282	26.00	0.1168	22.92
	25.03 <sup>#</sup>		24.16		23.42
0.1474	31.10				
	25.12				
0.1155	24.32				
	25.08				
Mean = 25.1 ± 0.3		Mean = 24.1 ± 0.3		Mean = 23.4 ± 0.3	

<sup>#</sup> Reaction catalysed by dimethyl cetyl amine (0.05 g/100 ml alcohol).

TABLE XIII

The Heat of o-Tolyl Isocyanate Reactions at 25°C.

<u>n-Butyl Alcohol</u>		<u>1-Butyl Alcohol #</u>		<u>s-Butyl Alcohol #</u>	
Weight o-tolyl iso-cyanate (gm)	Heat measured cal.	Weight o-tolyl iso-cyanate (gm)	Heat measured cal.	Weight o-tolyl iso-cyanate (gm)	Heat measured cal.
	kcal.mole <sup>-1</sup>		kcal.mole <sup>-1</sup>		kcal.mole <sup>-1</sup>
0.1257	22.10	0.1199	19.90	0.1267	20.65
	23.41		22.10		21.70
0.1198	21.04	0.1260	21.15	0.1263	20.53
	23.38		22.00		21.64
0.1168	20.60	0.1281	21.25	0.1257	20.55
	23.48		22.09		21.76
0.01605	2.840	0.1168	19.84		
	23.55		22.16		
	Mean = 23.5 ± 0.3		Mean = 22.1 ± 0.3		Mean = 21.7 ± 0.3

# Reaction catalysed with ferric acetylacetonate (0.15 g/100 ml alcohol).

TABLE XIV

The Heat of m-Tolyl Isoocyanate # Reactions at 25°C.

<u>n-Butyl Alcohol</u>		<u>i-Butyl Alcohol</u>		<u>s-Butyl Alcohol</u>	
Weight m-tolyl iso-cyanate (gm)	Heat measured cal.	Weight m-tolyl iso-cyanate (gm)	Heat measured cal.	Weight m-tolyl iso-cyanate (gm)	Heat measured cal.
	Heat of Reaction kcal.mole <sup>-1</sup>		Heat of Reaction kcal.mole <sup>-1</sup>		Heat of Reaction kcal.mole <sup>-1</sup>
0.1784	26.11	0.1750	25.10	0.1918	26.65
0.1692	24.84	0.1779	25.52	0.1848	26.05
0.1710	25.00	0.1809	25.89	0.1811	25.21
Mean = 19.5 ± 0.3		Mean = 19.1 ± 0.3		Mean = 18.5 ± 0.3	

#The urethanes of m-tolyl isoocyanate are in the liquid state at 25°C.

TABLE XV

The Heat of *o*-Tolyl Isoocyanate Reactions at 25°C.

<u>n-Butyl Alcohol</u>			<u>i-Butyl Alcohol</u>			<u>s-Butyl Alcohol</u> <sup>#</sup>		
Weight p-tolyl iso- cyanate (gm)	Heat measured cal.	Heat of Reaction kcal.mole <sup>-1</sup>	Weight p-tolyl iso- cyanate (gm)	Heat measured cal.	Heat of Reaction kcal.mole <sup>-1</sup>	Weight p-tolyl iso- cyanate (gm)	Heat measured cal.	Heat of Reaction kcal.mole <sup>-1</sup>
0.1370	25.44	24.74	0.1405	25.35	24.02	0.1534	27.12	23.54
0.1256	22.98	24.75	0.1201	23.23	23.96	0.1537	27.10	23.47
0.1222	22.65	24.65	0.1315	23.60	23.90 <sup>##</sup>	0.1482	26.45	23.76
0.1198	22.30	24.76	0.1311	23.50	23.66 <sup>##</sup>	0.1548	27.50	23.55
0.1191	22.10	24.71				0.1485	26.35	23.62
	Mean = 24.7 ± 0.3			Mean = 23.9 ± 0.3			Mean = 23.6 ± 0.6	

<sup>#</sup> A small amount of *N,N'*-di-*p*-tolyl urea was formed. The amount is estimated to be less than 5%.

<sup>##</sup> Reaction catalysed with ferric acetyl acetate. (0.15 g/100 ml. alcohol).

TABLE XVI

The Heat of 2,4-Tolylene Diisocyanate Reactions at 25°C.

Weight 2,4- tolylene diiso- cyanate (gm)	n-Butyl Alcohol			1-Butyl Alcohol #			s-Butyl Alcohol ##		
	Heat measured cal.	Heat of Reaction kcal.mole <sup>-1</sup>	Weight 2,4- tolylene diiso- cyanate (gm)	Heat measured cal.	Heat of Reaction kcal.mole <sup>-1</sup>	Weight 2,4- tolylene diiso- cyanate (gm)	Heat measured cal.	Heat of Reaction kcal.mole <sup>-1</sup>	Weight 2,4- tolylene diiso- cyanate (gm)
C.1114	28.18	44.03	0.0944	23.11	42.61	0.0879	20.86	41.51	0.1034
O.1008	25.46	43.96	0.1005	24.67	42.73	0.0943	22.40	41.35	0.1077
O.1012	25.58	44.00	0.0939	22.80	42.45	0.1077	25.60	41.37	0.1034
O.0951	24.04	44.00	0.1011	24.85	42.78	0.1034	24.58	41.58	
	Mean = 44.0 ± 0.6			Mean = 42.6 ± 0.9			Mean = 41.5 ± 0.6		

# U, N', -2,4-tolylene di-1-butyl urethane is slow to dissolve in 1-butyl alcohol. It was necessary to stir the second cell violently to achieve solution, with a considerable decrease in experimental reproducibility.

## Reaction catalysed by Ferric acetylacetonate. (0.15 g/100 ml alcohol).

TABLE XVII

Summary of Heats of Reaction  
(kcal. mole<sup>-1</sup>)

Isocyanate	n-BuOH	i-BuOH	s-BuOH
phenyl	25.1 ± 0.3	24.1 ± 0.3	23.4 ± 0.3
o-tolyl	23.5 ± 0.3	22.1 ± 0.3	21.7 ± 0.3
m-tolyl	19.5 ± 0.3	19.1 ± 0.3	18.5 ± 0.3
p-tolyl	24.7 ± 0.3	23.9 ± 0.3	23.6 ± 0.6
2,4-tolylene diisocyanate	44.0 ± 0.6	42.6 ± 0.9	41.3 ± 0.6

This heats of reaction presented in this table are evolved heats.

### DISCUSSION

There are not sufficient data available in the literature to permit the calculation of the heat of formation of each of the reactants involved in the reactions under investigation. However, it is possible to obtain an estimate of the heat of formation of the isocyanates by using an empirical bond energy scheme coupled with the heat of combustion value for ethyl isocyanate as determined by Lemoult (34). From the estimated heat of formation of the isocyanates and the measured heats of reaction, the heat of formation of the urethanes can be approximated.

Lemoult reports the heat of combustion of ethyl isocyanate as 424.4 kcal. mole<sup>-1</sup>. This value is the result of three determinations; the experimental precision of his determinations was about 0.2%. The combustion products were not analysed nor was the calorie he used defined. No corrections have been applied to this heat of combustion because the subsequent calculations do not warrant such accuracy.

Lemoult's value for ethyl isocyanate is used to obtain a bond contribution to the heat of atomization for the -NCO group. Using equation (3) of Part I, the heat of atomization of ethyl isocyanate is calculated to be 976.3 kcal. mole<sup>-1</sup>. Letting  $n$  represent the contribution of the -NCO group to the heat of atomization, and with the

other bonds as in Part I, one obtains

$$c_1 + 3p + 2s + n = 976.3.$$

Use of the known values of  $c_1$ ,  $p$ , and  $s$  from Laidler (10) yields

$$n = 397.6 \text{ kcal.}$$

Preliminary work on a bond energy scheme for aromatic compounds indicates that special values should be assigned to carbon-carbon bonds in an aromatic ring, and to carbon-hydrogen bonds, where the carbon is part of such a ring. Preliminary calculations suggest, for compounds in the liquid state, a value of 124.29 kcal. for the carbon-carbon bond, denoted by  $c_b$ , and a value of 97.55 kcal. for the carbon-hydrogen bond,  $t_b$ . These values, plus the contribution of the isocyanate group,  $n$ , yield, for the heat of atomization of phenyl isocyanate;

$$6 c_b + 5 t_b + n = 1631.01 \text{ kcal. mole}^{-1}.$$

From this heat of atomization, the heat of formation,  $Q_f$ , of phenyl isocyanate can be calculated using equation (1) of Part I.

$$Q_f = Q_a - 171.7 n_C - 52.09 n_H - 59.16 n_O - 113 n_N \quad (1)$$

From this equation  $Q_f$  is found to be  $- 3.5 \text{ kcal. mole}^{-1}$ ; hence  $\Delta H_f^\circ = 3.5 \text{ kcal. mole}^{-1}$ . Similarly, for the tolyl isocyanates,  $\Delta H_f^\circ$  is calculated to be  $- 5.3 \text{ kcal. mole}^{-1}$ . It is expected that two isocyanate groups on an aromatic ring would lead to considerable interaction; this would affect the heat of formation, which therefore has not been calculated for 2,4-tolylene diisocyanate.

Only one heat of formation can be calculated for the three tolyl isocyanates because there are insufficient data to calculate a correction due to the position of the methyl group. The differences are not liable to be large; for example, the heats of formation of ortho, meta, and para xylene are  $- 4.5$ ,  $- 4.1$ , and  $- 4.3 \text{ kcal. mole}^{-1}$  respectively.

The most recent determination of the heats of formation of butyl alcohols was made by Skinner and Snelson (35). For normal, iso, and secondary butyl alcohols, in the liquid state at  $25^\circ\text{C}$ . they report values of  $- 78.49 \pm 0.20$ ,  $- 80.00 \pm 0.20$  and  $- 81.88 \pm 0.22 \text{ kcal. mole}^{-1}$  respectively.

The measured heat of reaction data apply to urethanes in the solid state, except for the urethanes formed from *m*-tolyl isocyanate which are liquids at  $25^\circ\text{C}$ . Using the measured heats of formation of the alcohols, the

measured heats of reaction, and the calculated heats of formation of the isocyanates, the heats of formation of the product urethanes at 25°C. can be calculated. The reaction under consideration is,

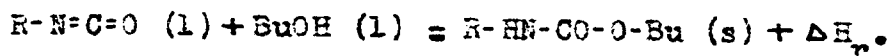

As an example, consider the reaction between normal butyl alcohol and phenyl isocyanate. The measured heat of this reaction is 25.1 kcal. mole<sup>-1</sup>.

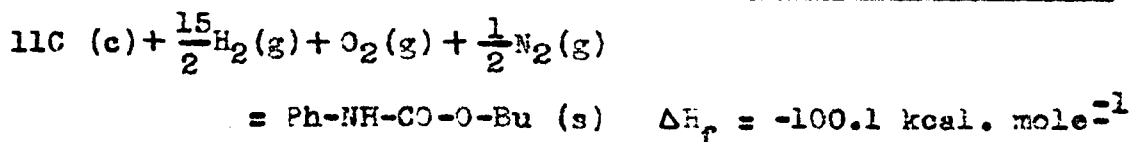
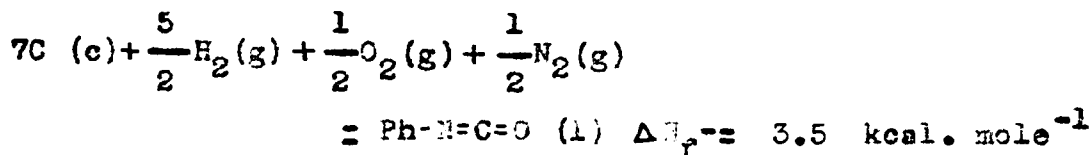
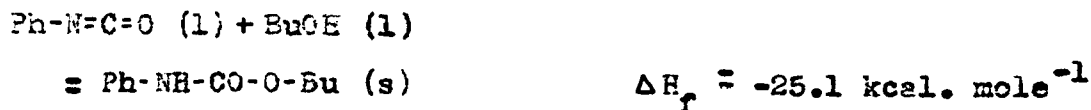

The heats of formation of the other urethanes produced in these experiments are given in Table XVIII.

Using the calculated heats of formation of urethanes, the contribution to the heat of atomization of a urethane group (-NHCOO-) can be calculated. Since the bond scheme is for liquids n-m-tolyl-n-butyl urethane is used to calculate the urethane group contribution to the heat of atomization because this compound is a liquid at 25°C.

TABLE XVIII

Calculated Heats of Formation of Urethanes at 25°C.

Urethane	State	$\Delta H_f^\circ$ (kcal. mole <sup>-1</sup> )
<u>N</u> '-phenyl-n-butyl	c	-100
<u>N</u> '-phenyl-i-butyl	c	-101
<u>N</u> '-phenyl-s-butyl	c	-102
<u>N</u> '-p-tolyl-n-butyl	c	-107
<u>N</u> '-p-tolyl-i-butyl	c	-107
<u>N</u> '-o-tolyl-s-butyl	c	-109
<u>N</u> '-m-tolyl-n-butyl	l	-103
<u>N</u> '-m-tolyl-i-butyl	l	-104
<u>N</u> '-m-tolyl-s-butyl	l	-105
<u>N</u> '-p-tolyl-n-butyl	c	-108
<u>N</u> '-p-tolyl-i-butyl	c	-109
<u>N</u> '-p-tolyl-s-butyl	c	-111

The calculated heat of atomization of liquid N-m-tolyl-n-butyl urethane is 3280.8 kcal. mole<sup>-1</sup>. The sum of the bonds is

$$6 c_b + 4 t_b + 4 c_l + 6 p + 6 s + u = 3280.8$$

where u is the contribution of the urethane group to the heat of atomization. The value of u is found to be 626.6 kcal. for urethanes in the liquid state.

It must be borne in mind that the heats of formation of the isocyanates calculated from Lemoult's determination of the heat of combustion of ethyl isocyanate may be (and probably are) in error by several kilocalories. Nevertheless, it is better to have approximate values for the heat of formation of isocyanates and urethanes than no values at all.

The heats of reaction for reactions involving m-tolyl isocyanate are markedly different from those involving p-tolyl isocyanate, to which the meta compound should be comparable. This is because the urethanes formed from m-tolyl isocyanate are liquids in their standard state, while those formed from p-tolyl isocyanate are solids in the standard state. To see why this should give a large difference in the heat of reaction, consider a reaction at 25°C. giving rise to a solid urethane, and then the same reaction at the same temperature, yielding a supercooled liquid urethane. In going from solid urethane at 25°C. to supercooled liquid at the same temperature the following steps are taken:

$$\begin{array}{rcl}
 \text{urethane (s, } 25^\circ) & = & \text{urethane (s, mp}^\circ) \quad C_{p_1} (\text{mp}^\circ - 25^\circ) \\
 \text{urethane (s, mp}^\circ) & = & \text{urethane (l, mp}^\circ) \quad \Delta H_f \\
 \text{urethane (l, mp}^\circ) & = & \text{urethane (l, } 25^\circ) \quad -C_{p_2} (\text{mp}^\circ - 25^\circ) \\
 \hline
 \text{urethane (s, } 25^\circ) & = & \text{urethane (l, } 25^\circ) \quad (C_{p_1} - C_{p_2}) (\text{mp}^\circ - 25^\circ) \\
 & & \Delta H_f.
 \end{array}$$

Here  $\Delta H_f$  is the heat of fusion of the urethane at the melting point,  $C_{p_1}$  and  $C_{p_2}$  are the heat capacities of the solid and liquid urethanes respectively, and mp. is the melting point of the urethane. The heat change in going from solid to liquid urethane at  $25^\circ\text{C}$ . is

$$\Delta H_f + (\text{mp} - 25^\circ) (C_{p_1} - C_{p_2}).$$

The heat of a reaction can be calculated by subtracting the heat of formation of the reactants from the heat of formation of the products. Since, in the case under consideration, the heat of formation of the reactants is the same in both cases, the change in the heat of formation of the urethane must be reflected as a change in the heat of the reaction. The main difference between the heat of formation of the liquid and solid urethane is due to the heat of fusion. Hence, if the heat of fusion of the m-tolyl isocyanate urethanes were known, and added to the measured heat of reaction, direct comparison between the para and meta tolyl isocyanate reactions could be made, neglecting the difference in heat capacity of the two states. The heats

of fusion of the urethanes do not appear to be known.

Accurate absolute values for the heats of formation of the urethanes cannot be obtained from the data presently available. However, for a particular isocyanate, accurate relative values of the heats of formation can be obtained. Thus from Hess's law of heat summation, the heats of formation for phenyl isocyanate reactions are:

<u>N</u> -phenyl-n-butyl urethane	- 103.6 + A
<u>N</u> -phenyl-i-butyl urethane	- 104.1 + A
<u>N</u> -phenyl-s-butyl urethane	- 105.3 + A

where A is the heat of formation of phenyl isocyanate. The differences in these heats of formation are smaller than would be expected from consideration of the differences in the heat of formation of the three butyl alcohols concerned. For example, the difference in heat of formation of N-phenyl-n-butyl urethane minus that of N-phenyl-i-butyl urethane is 0.5 kcal.mole<sup>-1</sup> whereas the heat of formation of n-butyl alcohol minus that of i-butyl alcohol is 1.5 kcal.mole<sup>-1</sup>. Similarly, the heat of formation of N-phenyl-n-butyl urethane minus that of N-phenyl-s-butyl urethane is 1.7 kcal.mole<sup>-1</sup> whereas the heat of formation of n-butyl alcohol minus that of s-butyl alcohol is 3.4 kcal.mole<sup>-1</sup>. Urethanes

formed from *i*-butyl and *s*-butyl alcohols are not as stable as one would expect from consideration of the heats of formation of the alcohols alone.

The decreased stability of the *iso* and secondary butyl urethanes as compared to the normal urethane can be accounted for by the increase in steric hindrance in going from normal to *iso* to secondary butyl urethanes. There is in addition, a small inductive effect due to the butyl group which tends to push electrons into the urethane group, and thereby decreases its stability. The inductive effect also increases in going from normal to *iso* to secondary butyl urethanes. From the approximate heats of formation in Table XVIII it is seen that these conclusions apply in the case of every isocyanate. The largest difference in the heat of formation of a normal butyl urethane minus a secondary butyl urethane is  $3 \text{ kcal.mole}^{-1}$ , whereas the heat of formation of *n*-butyl alcohol minus *s*-butyl alcohol is  $3.4 \text{ kcal.mole}^{-1}$ .

The effects of a methyl group in the aromatic ring of the urethane can be predicted in terms of resonance, steric and inductive effects. Upon substitution of a methyl group into an aromatic nucleus partial negative charges appear in the *ortho* and *para* ring positions due to hyperconjugation. The inductive effect will also tend to place a negative charge on the ring, which will decrease in going from the

ortho to meta to para positions. The stability of ortho urethanes will be decreased by steric hindrance. From these considerations one would expect the heat of formation of the urethanes of a particular alcohol to decrease in going from ortho to para to meta substituted compounds. It is seen from Table XVIII that this is the case. The conclusions drawn concerning m-tolyl urethanes cannot be verified because the heats of formation for these compounds refer to the liquid state.

### PART III

## KINETICS OF REACTION

### INTRODUCTION

The kinetics of the reactions between phenyl and ortho, meta, and para tolyl isocyanates and each of normal, iso, and secondary butyl alcohol have been studied at a series of temperatures. Two techniques were used to follow these reactions: the usual analytical method of measuring the concentration of one of the reactants (isocyanate) at various times during the course of the reaction; and a thermal method, based on the relationship between the amount of heat produced at a given time, and the extent of reaction up to that time. These techniques of following the reaction will be discussed, followed by a discussion of the isocyanate-alcohol reactions.

### Rate Constants by Chemical Analysis

The isocyanate-alcohol reactions are first-order in isocyanate and first-order in alcohol. However in a large excess of alcohol, as was the condition here, the alcohol concentration remains essentially constant during the reaction, and the reaction appears to be first-order.

Such a reaction is called a pseudo first-order reaction (43), and can be described by the equation

$$\frac{dx}{dt} = kb (a-x) \quad (16)$$

where  $b$  is the concentration of alcohol,  $a$  is the initial concentration of isocyanate,  $x$  is the concentration of product at time  $t$ , and  $k$  is the rate constant. Upon integration, setting  $x = 0$  when  $t = 0$ , equation (16) becomes

$$k = \frac{1}{tb} \ln \frac{a}{a-x} \quad (17)$$

where  $(a-x)$  and  $t$  are measured experimentally, and  $a$  is known from the initial conditions;  $k$  can be calculated directly from the experimental data.

Experimental data may also be treated by the differential method. The reaction rate is proportional to the concentration of the reactant, so that

$$-\frac{dc}{dt} = kc^n, \quad (18)$$

where  $c$  is the concentration of reactant and  $n$  is the order of the reaction. Taking logarithms gives

$$\log (-dc/dt) = \log k + n \log c. \quad (19)$$

If  $\log (-dc/dt)$  is plotted against  $\log (c)$  a straight line will result if there are no complicating features about the reaction. The slope of the line will give the order of the reaction and the intercept will give the rate constant. If a curved line is obtained the initial rate constant can be obtained by extrapolation.

The differential method is probably the better of the two methods since it does not constrain the data to fit a preconceived idea of what the kinetics of the reaction ought to be. However, if the order of the reaction is definitely established, then more accurate values for the rate constant can be calculated from equation (17). Both methods have been used here.

#### Thermal Method

The method of following the kinetics of a reaction by the temperature change produced as the reaction proceeds has been developed primarily for use with reactions which are too fast to permit employment of the usual chemical methods. It appears that the use of a thermal method was first suggested by Hartridge and Roughton (44) in connection with a flow system technique. For reactions in non-flowing systems, Ball and Clunie (45) have given a theoretical treatment of first and second-order reactions, and have verified their treatment experimentally. The treatment of

Bell and Clunie relates the maximum temperature obtained during the reaction to the rate constant of the reaction. The method requires that the heat of reaction for the reaction in question, and the cooling constant of the reaction vessel, be known.

For the first-order case Bell and Clunie give, for the rate of change of temperature,  $T$ , with time,  $t$ ,

$$\frac{dT}{dt} = k_1 T_0 e^{-k_1 t} - k_2 T \quad (20)$$

where  $k_1$  is the first-order rate constant of the reaction and  $T_0$  is the temperature change which would be produced by the reaction under adiabatic conditions. The rate of heat exchange with the surroundings is governed by  $k_2$ , which is assumed to be a first-order constant. Integration of equation (20) with  $T = T_1$  when  $t = 0$  gives:

$$T = \frac{T_0 k_1}{k_2 - k_1} \left[ \frac{e^{-k_1 t}}{-k_1} - \frac{e^{-k_2 t}}{-k_2} \right] + T_1 e^{-k_2 t} \quad (21)$$

Maximizing equation (21) and setting  $T = T_m$  and  $t = t_m$  at the maximum gives

$$\frac{T_m}{T_0} = \frac{1}{R} (R + R - R^2)^{1/(1-R)} \quad (22)$$

where  $R = (k_2/k_1)$  and  $\rho = (T_1/T_0)$ . By the proper choice of experimental conditions, or by compensating for the heat of mixing,  $T_1$  can be made zero, in which case equation (22) becomes

$$\frac{T_m}{T_0} = \left( \frac{k_1}{k_2} \right)^{k_2/(k_2-k_1)} \quad (23)$$

$T_m$  and  $k_2$  are measured experimentally, and  $T_0$  is calculated from the heat of the reaction, permitting  $k_1$  to be obtained from equation (23).

The application of this method to the data obtained from the calorimeter is not convenient because of the difficulty of obtaining  $T_0$ , the temperature (or in the case of the calorimeter the E. N. F.) that would result if the reaction took place under adiabatic conditions.

Fortunately, a simpler method of treating the calorimetric data, to obtain the first-order rate constant, does exist. This method, due to Baumgartner and Duhaut (46), is ideally suited to the problem at hand; with it the first-order rate constant can be deduced from the calorimetric data obtained during heat of reaction measurements with no further experimental work. Baumgartner's method has been used to obtain rate constants for several reactions from the calorimetric charts. These charts record the E. N. F. due to the heat produced by a reaction or by

electrical heating as a function of time, and also the integral of the E. M. F. versus time curve as a function of time. Schematic curves of this type appear in Figure 4: curve 4a shows the variation with time of the E. M. F. due to a chemical reaction and 4b is the integral of the curve in 4a, also as a function of time; curve 4c shows the E. M. F. variation with time due to electrical heating, and 4d is the integral of this curve.

The method of extracting the first-order rate constant from these data is as follows. Imagine that the chemical reaction can be stopped at any time  $t$ . If this were done, the reaction cell would cool down in exactly the same way that it cools down when the electric current is cut off after an electrical heating, and the area under this imaginary curve would be a measure of the amount of material reacted from  $t = 0$  to  $t = t$ .

Imaginary curves of this kind can be constructed from the E. M. F. versus time plots for chemical reaction, and for electrical heating. The shaded area A in Figure 4a is a measure of the heat evolved by a chemical reaction from  $t = 0$  to  $t = t$ . The reaction is thought of as being stopped at time  $t$ . The heat remaining in the reaction cell at time  $t$  evolves according to the heat evolution characteristics of the reaction cell, as measured by a simple cooling of the cell, such as is obtained when an electrical heating is discontinued. Hence, the area of a

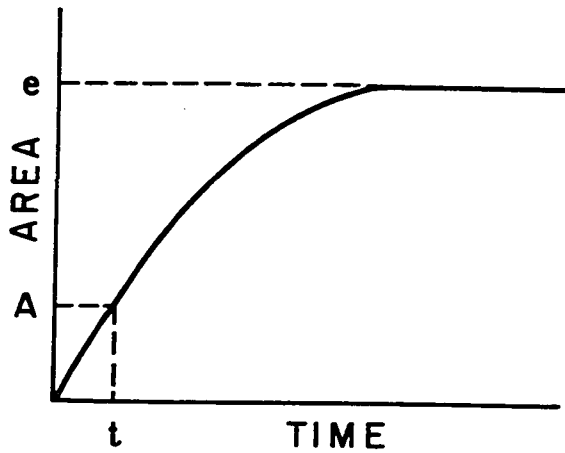

Figure 4b Integrator chart for a chemical reaction.

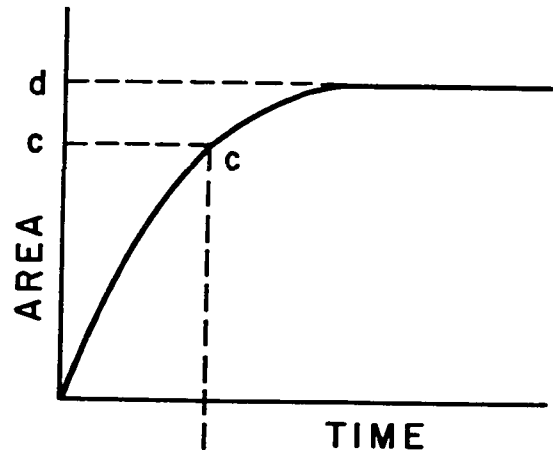

Figure 4d Integrator chart for an electrical heating.

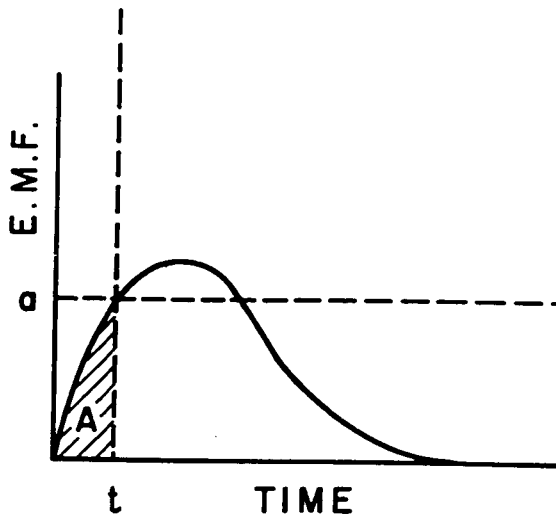

Figure 4a Amplifier chart for a chemical reaction.

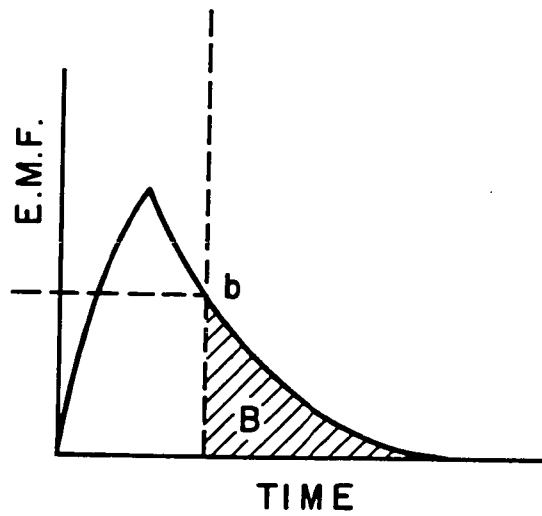

Figure 4c Amplifier chart for an electrical heating.

simple cooling curve between E. M. F. =  $a$  and E. M. F. = 0 is a measure of the unevolved heat in the reaction cell when the reaction is stopped at time  $t$ . This area is shown as shaded area B in Figure 4c. The sum of Area A in Figure 4a and area B in Figure 4c gives the total heat of reaction up to time  $t$ . This is a direct measure of the amount of reactant which has reacted at time  $t$ . The ratio of the total heat evolved by the reaction at infinite time to the total heat produced at time  $t$  is a direct measure of  $a/x$ , where  $a$  is the initial concentration of reactant, and  $x$  is the amount reacted at time  $t$ . Using the ratio  $a/x$  and the time, which is obtained directly from the known chart speed, the rate constant  $k$  is readily calculated using equation (17).

#### The Kinetics of Alcohol Isocyanate Reactions

The kinetics of the well known reaction between alcohols and isocyanates have been studied by several investigators. A mechanism for the reaction has been proposed, and subsequent investigations have yielded results supporting this mechanism, while none of the data presently available are incompatible with it.

It appears that the first measurement of alcohol-isocyanate reaction rates was made by Davis and Farnum (47). Lacking a means to analyse for either reactant, they

measured relative reaction rates by forcing two alcohols to compete for a limited amount of isocyanate. The ratio of the two product urethanes was obtained by referring the melting point of the mixture to a freezing-point diagram of the urethanes.

Shortly after the second World War a method for the direct determination of isocyanate groups became available (48). Making use of this analytical procedure Baker and Holdsworth, Baker and Gaunt, and Baker, Gaunt, and Davies (49, 50, 51) carried out extensive studies of alcohol-isocyanate reactions. Their work consisted mainly of studies concerning the reaction between phenyl isocyanate and methyl, ethyl, and isopropyl alcohols. The rates of these same reactions in the presence of various tertiary amines were also studied.

Based upon their experimental observations, Baker and his coworkers proposed the following mechanism for the uncatalysed alcohol-isocyanate reaction:

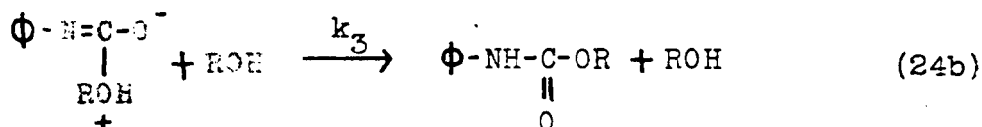
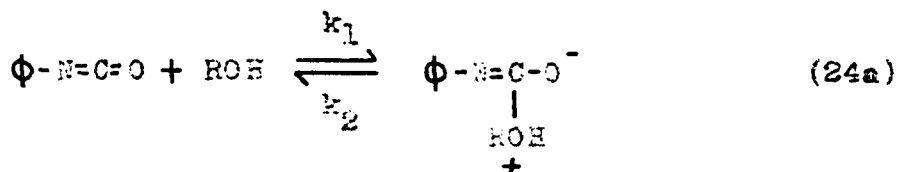

The alcohol is believed to function as a catalyst through its basic oxygen atom, as well as a reactant. Application of the steady-state treatment to this mechanism yields the following relationship:

$$\frac{(ROH)}{k_0} = \frac{k_2}{k_1 k_3} + \frac{(ROH)}{k_1} \quad (25)$$

where  $k_0$  is the experimental second-order rate constant. Because of catalysis by the reaction product, equation (25) will hold only during the initial stages of the reaction.

The validity of the mechanism can be tested by plotting  $(ROH)/k_0$  vs.  $(ROH)$ . If the proposed mechanism is correct, then a straight line, with a slope of  $1/k_1$  and an intercept of  $k_2/k_1 k_3$ , will be obtained. This has been done for the reactions between phenyl isocyanate and methyl, ethyl, and isopropyl alcohols at 20° and 30°C., in di-n-butyl ether solution, yielding straight line relationships at both temperatures. At low alcohol concentrations when there is insufficient alcohol to supply both stages of the mechanism, there is some deviation from the straight line.

As is seen from the proposed mechanism, the reaction is believed to take place by addition to the carbonyl group of the isocyanate. If this is the case, the unshared electrons on the adjacent nitrogen atom will tend

to retard the reaction because of conjugation within the isocyanate group. An aryl group attached to the nitrogen atom would allow these electrons to conjugate with the ring, and hence facilitate the carbonyl addition. This view is supported by the general experience that aryl isocyanates react much faster with alcohols than alkyl isocyanates. The introduction of electron repelling groups into the aromatic ring decreases the conjugation of the isocyanate group, and reduces the reaction velocity. Electron attracting substituents will have the opposite effect. Baker has given evidence to support this deduction by showing that the reaction rates of  $N$ -NCO compounds increase as the electron withdrawing power of the substituent,  $R$ , increases. The rate increases in the order:

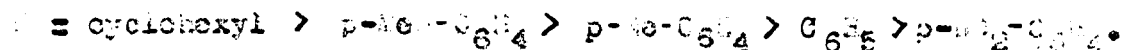

It would be expected that steric effects would decrease the reaction rate as the length of the alcohol increased. In the first stage of the reaction the alcohol acts as a weak base. The ease of complex formation, and the stability of the complex ought to increase as the basic strength of the alcohol increases. Increasing electron release in the alkyl chain will increase the basicity of the alcohol. For the alcohols involved here, the order of increasing basicity is:  $t\text{-Bu} > i\text{-Pr} > Et > Me$ . Stage 2 of the reaction, if the transition complex is of the type

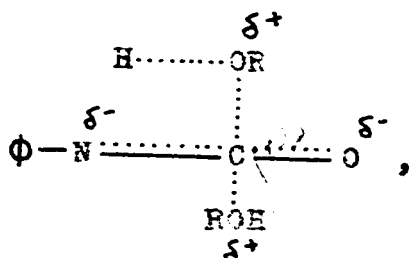

will be hindered by increasing basicity and increasing steric effects. These considerations indicate the existence of a maximum velocity in a graded polar series. Such a maximum does exist; the velocities are in the order Me < Et > i-Pr > t-Bu.

The second-order rate constant dependence upon the alcohol-isocyanate ratio is thought to be due to solvation effects. That is, solvation of the activated complex by polar alcohol molecules will help stabilize the complex, and increase the reaction rate.

The alcohol-isocyanate reactions are found to be considerably faster in benzene solution than in dibutyl ether solution. The same mechanism is believed to apply, since a plot of  $(\text{ROH})/k_0$  vs.  $(\text{ROH})$  gives a straight line. It is found that the values of  $k_1$  are slightly larger in benzene solution, but that  $k_3/k_2$  is much larger. The small increase in  $k_1$  may be due to more effective solvation of the activated complex by monomeric alcohol molecules. The large increase in  $k_3/k_2$  is attributed to an increase in  $k_3$ , brought about by the presence of unassociated alcohol molecules which can react more easily with the activated complex, because of their greater ease of approach to it, and because no energy is

required to break hydrogen bonds. These conclusions are supported by infra-red studies which show the presence of considerable unassociated alcohol in benzene solution, but not in dibutyl ether solution.

Baker et al. have shown that  $E_1$ , the activation energy associated with  $k_1$ , and the frequency factor  $PZ_1$  increase together as the size of the alcohol molecule increases. They point out that such changes usually occur in reactions when solvation energy and entropy are important.

The mechanism suggested for reactions catalysed by tertiary amine is similar to that for the uncatalysed reaction.

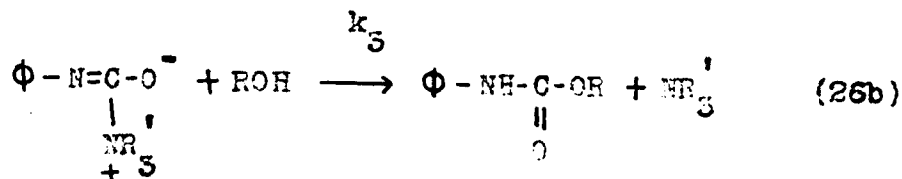
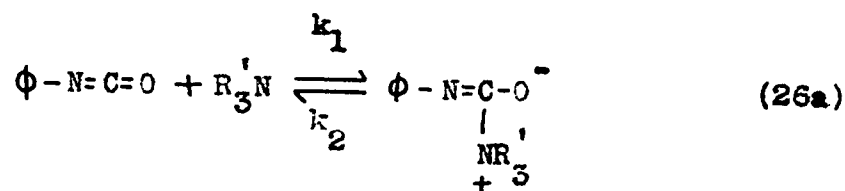

Applying the steady-state treatment, the following relationship is obtained.

$$\frac{(\overline{R}_3)}{k_{bi}} = \frac{1}{k_c} = \frac{k_2}{k_1 k_3} + \frac{(R_3)}{k_1} \quad (27)$$

Plotting  $(\overline{R}_3)/k_{bi}$  vs.  $(R_3)$  should give a straight line of slope  $1/k_1$  and intercept  $k_2/k_1 k_3$ . Such straight lines are obtained experimentally. This mechanism predicts that  $k_1$  will be independent of the nature of the alcohol undergoing reaction. It has been found by experiment that this is not the case. This anomaly is attributed to the dependence of  $k_1$  on the solvation effect of the alcohol. On this basis  $k_1$  should increase as the polarity of the alcohol increases and the steric effects decrease; the reaction rate should be  $\text{Me} > \text{Et} > \text{iPr}$ . This predicted order has been verified experimentally.

A second possible explanation for the variation of  $k_1$  is that both free amine and alcohol-amine pairs can catalyze the reaction. However, if this were the case the straight line relationship would not be obtained. It would also not be obtained if only the alcohol-amine pair were the effective catalyst.

The possibility that the activated complex consists of an alcohol and amine molecule, which subsequently reacts with an isocyanate to give the product, has also been considered. This possibility has been rejected, however,

because of the behaviour of dialkylanilines. These compounds exhibit little catalytic activity, in contrast to compounds such as pyridine of similar basicity. If the activated complex does consist of an alcohol-amine combination there is no reason for the anomalous behaviour of these anilines. On the other hand, Baker has shown that considerably more energy is required to bring the nitrogen of the amine up to a given distance from the isocyanate carbon when the amine is dialkylaniline than if it is, for example, triethylamine.

The rates of the catalysed reactions are, like those of the uncatalysed reactions, much higher in benzene solution than in dibutyl ether. Furthermore, the second-order rate constant,  $k_{bi}$ , increases more rapidly in benzene than in dibutyl ether as the alcohol concentration is increased. This increase is attributed to the greater importance of solvation by the alcohol in benzene solutions. The over-all rate increase in benzene solution is again attributed to the effect of unassociated alcohol molecules on the second step of the reaction mechanism. The decrease of the activation energy with the frequency factor is taken to be an indication of the importance of solvent effects.

In concluding the series of papers in which the above work is reported Baker states, "Summarising the whole field . . . . it seems justifiable to conclude that the

mechanisms for the . . . reactions of phenyl isocyanate with alcohols . . . are essentially correct, but that serious complications are introduced as a result of association and solvation. These latter factors, whilst capable of qualitative interpretation in the light of the experimental data, are not amenable to quantitative treatment on the basis of kinetic studies alone."

Ephraim, Woodward, and Mesrobian (52) studied the reaction between phenyl isocyanate and methyl alcohol at 20°C in various solvents. They report that the logarithm of the rate constant decreases as the dielectric constant of the solvent increases. To support this claim Ephraim et al. present the data which have been plotted in Figure 5. These authors also report that deviations from second-order kinetics increase as the hydrogen bonding capabilities of the solvent increase. They find that reactions in toluene and nitrobenzene show positive deviations, those in methyl ethyl ketone and acetonitrile show none, and those in n-butyl acetate and dioxane show negative deviations. Based upon this experimental work, Ephraim et al. propose a mechanism of the type:

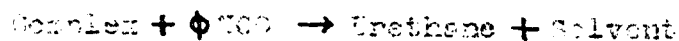
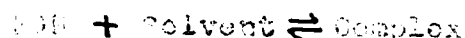

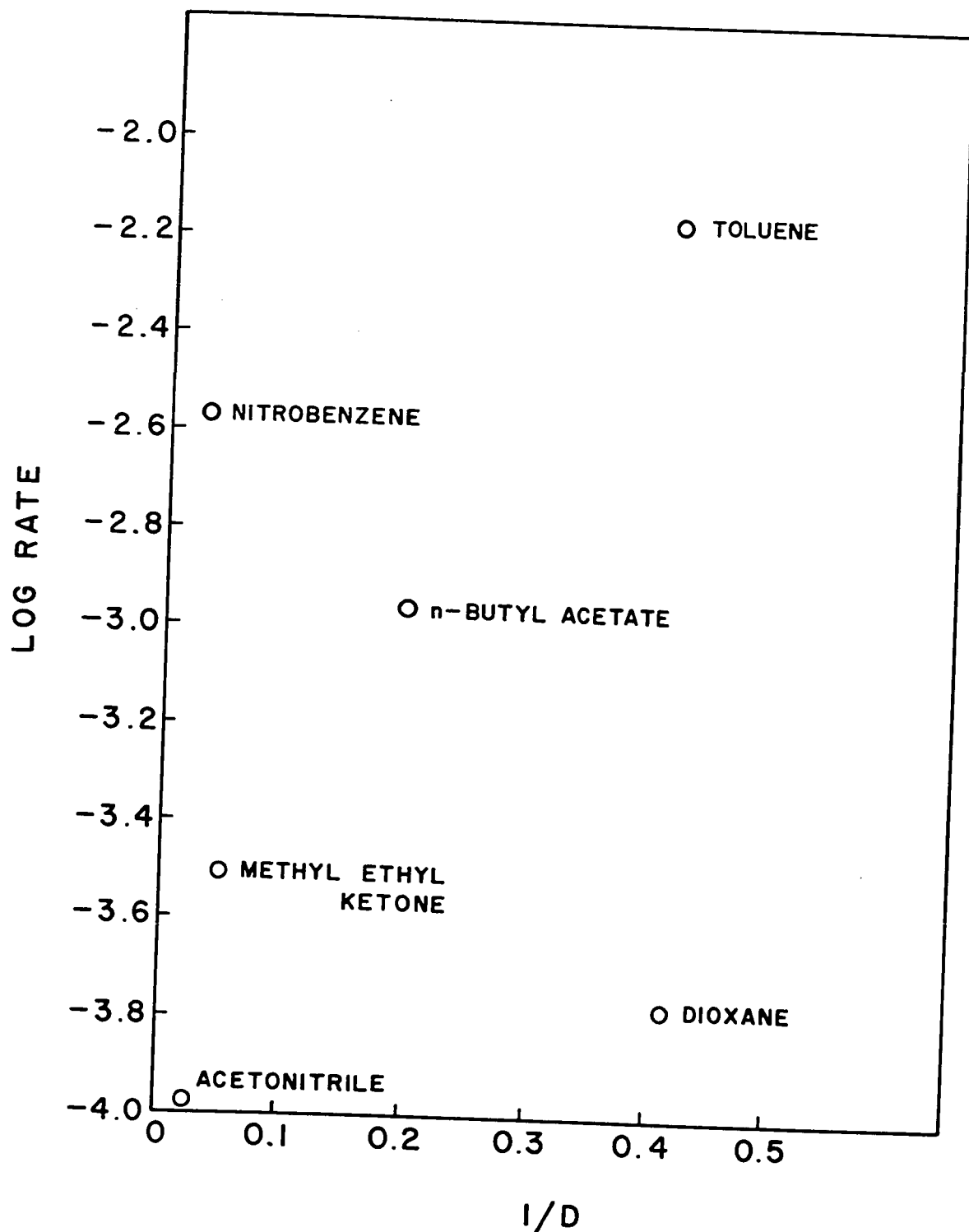

Figure 5 Ephraim's data: log rate constant plotted against the reciprocal of the dielectric constant for the reaction of phenyl isocyanate with methyl alcohol in a series of solvents.

They offer no experimental test of the proposed mechanism and they fail even to mention Baker's argument that this type of mechanism is not probable.

The rate of the reactions between phenyl isocyanate and normal and secondary butyl alcohol in xylene solution has been studied by Dyer et al. (41) at a series of temperatures. These authors interpret their results in the light of the Baker mechanism. For a 5:1 ratio of alcohol to isocyanate at 25°C, the observed second-order rate constants are  $4.32 \times 10^{-4}$  and  $1.51 \times 10^{-4}$  liters mole<sup>-1</sup> sec.<sup>-1</sup> for normal and secondary butyl alcohols respectively. The Arrhenius activation energies for an alcohol isocyanate ratio of 2:1 are 8.1 and 9.9 kcal. mole<sup>-1</sup> for normal and secondary butyl alcohols respectively.

The reactivity of o- and p-tolyl isocyanates toward ethyl alcohol have been investigated by Kogon (53). The reaction rates were measured in the presence of triethylamine, which catalyses the reactions. The second-order rate constants for phenyl, o-tolyl, and p-tolyl are in the ratio of 1:0.12:0.47, under the experimental conditions.

The kinetics of triethylamine-catalysed reactions of some isocyanates and diisocyanates reacting with normal butyl alcohol are reported by Turkus and Eckert (54). Here, all the reactions studied were base catalysed. The second-order rate constants for phenyl, o-tolyl, and p-tolyl isocyanates were in the ratio of 1:0.15:0.3.

Reactions of 1-alkenyl isocyanates with methanol have been studied by Sato (55).

### EXPERIMENTAL

The rate of reaction between phenyl and the three isomers of tolyl isocyanate with normal, iso, and secondary butyl alcohol was measured at a series of temperatures. In every case the alcohol was present in large excess, so that the reactions fall into the pseudo first-order class.

#### Purity of Materials

The methods used to purify the reagents were described in Part II of this thesis.

#### Analysis of Isocyanate Groups

The isocyanate groups were determined by a modification of Stagg's technique (48). The method consists of allowing the unknown isocyanate to react with an excess of standard di-n-butyl amine in toluene, and back titrating the excess amine with standard hydrochloric acid solution.

Solutions of amine in dry toluene were made up to be approximately 0.1N. The hydrochloric acid solution, approximately 0.02 normal, was standardized by a gravimetric

determination of chloride, with silver nitrate reagent (56). The titer of the amine solution was determined by blank titrations of 10 ml of the solution. The method of analysis is as follows.

Ten ml of the amine solution were pipetted into an Erlenmeyer flask. The unknown isocyanate was added and the flask shaken. Fifty ml of isopropyl alcohol were added along with two drops of a solution of bromphenol blue indicator (0.04% in water). The resulting solution was titrated with standard hydrochloric acid solution. Isopropyl alcohol prevents the formation of a second phase during the titration. The amount of isocyanate is calculated by subtracting the volume of hydrochloric acid used, from the volume of it used in a blank titration, and multiplying by the normality of the hydrochloric acid. This gives the number of equivalents of isocyanate present in the unknown, which can be converted to grams by multiplying by the molecular weight.

#### Constant Temperature Baths

Two baths were used, one for reactions carried out at 25°C. and above, and a refrigerated bath for reactions at temperatures below that of the room.

The bath for use at room temperature and above consisted of an 18 liter vessel, containing commercial anti-freeze (ethylene glycol). It contained a stirrer and a cooling coil connected to a cold water tap. A thermometer

Temperature Controller, Model 71, manufactured by The Yellow Springs Instrument Company, was used to control an electric heating coil suspended in the bath. The temperature of the bath was held constant to within a tenth of a degree.

For temperatures below 25°C. a refrigerated bath manufactured by the American Instrument Company was used. A bimetallic strip thermoregulator was used as a temperature sensing device. This bath also held a constant temperature to within a tenth of a degree.

#### Experimental Procedure

The kinetic experiments were carried out so as to be directly comparable to the reactions studied in the micro-colorimeter. The rates of the reactions were measured at a series of temperatures, enabling the Arrhenius activation energy to be calculated. As an example, consider the reaction between phenyl isocyanate and n-butyl alcohol.

Approximately 35 ml of n-butyl alcohol were placed in a tared 100 ml round bottom flask with a 24/40 ground glass neck. The flask and alcohol were weighed to obtain the weight of the alcohol. The flask was then tightly stoppered and placed in the constant temperature bath. Approximately 1 ml of phenyl isocyanate, and a hypodermic syringe, were placed in a test tube fitted with a ground glass stopper. The stoppered test tube was weighed and placed in the thermostat. At least a half hour was allowed

for the reactants to come to temperature equilibrium with the bath.

The reaction was started by transferring about 1/2 ml of phenyl isocyanate from the test tube to the flask containing the alcohol by means of the hypodermic syringe. An electric stop-watch was started at the moment the isocyanate was added to the alcohol. The syringe was then put back into the test tube, and the test tube was stoppered. The flask containing the alcohol and isocyanate was shaken vigorously for a few seconds to mix the reactants. The test tube containing the syringe was removed from the bath, dried, allowed to come to room temperature, and weighed, to obtain the weight of isocyanate added to the alcohol.

At regular intervals during the course of the reaction 5 ml samples of the reaction mixture were withdrawn by means of a pipette. The reacting mixture was discharged from the pipette into an Erlenmeyer flask containing 10 ml of a solution of dibutyl amine in toluene. The time at which the pipette was half empty was recorded. The phenyl isocyanate reacts rapidly with the amine, thereby stopping the reaction. During the course of the reaction 5 ml of the reacting mixture was put into a tared weighing bottle, allowed to come to room temperature and weighed. This was done so that the subsequent calculations could be made entirely on a weight basis.

Upon withdrawal of the required number of samples (usually five for each run) isopropyl alcohol and bromphenol blue indicator were added to each Erlenmeyer flask, and the excess amine was titrated with hydrochloric acid.

The rate of each reaction was measured at three or four temperatures, and usually two runs were made for each reaction at each temperature.

#### Calculation of the Rate Constant from Chemical Analysis Data

The experimental results were used to calculate the rate constant from equation (17); the integrated expression for a first-order reaction. This equation is:

$$k = \frac{1}{tb} \ln \frac{a}{a-x}, \quad (17)$$

where  $t$  is the time (seconds),  $b$  is the alcohol concentration,  $a$  is the initial concentration of isocyanate, calculated from the weight of alcohol and the weight of isocyanate,  $(a-x)$  is the concentration of isocyanate at time  $t$ , and  $k$  is the rate constant.

In addition, the data were treated so as to obtain the differential rate constant. This is done by plotting  $\log d(a-x)/dt$  versus  $\log(a-x)$ . If the reaction is simple, the slope of the line will give the order, and the intercept will

give the rate constant. The slopes,  $d(a-x)/dt$ , were found by plotting  $(a-x)$  versus  $t$ . A cubic power series in  $t$  was fitted to this curve by means of a Gerber Equameter, and  $d(a-x)/dt$  at time  $t$  was found by differentiating the power series. Extrapolation of the curve of  $\log d(a-x)/dt$  versus  $\log (a-x)$  yields the initial rate constant.

#### Calculation of the Rate Constant from Calorimetric Data

The rate constant was obtained from the calorimetric charts in the following manner. Charts describing a chemical reaction and an electrical calibration were arranged on a drawing board in the order shown in Figure 4. A series of times were arbitrarily selected, usually at fixed intervals, and covering about 75% of the total reaction.

The magnitude of area A is obtained by reading the area directly from the curve of area versus time for the chemical reaction at time  $t$  (figure 4b). Area B is obtained by constructing a line from a to b, and then from b to c as shown in Figure 4. The magnitude of area B is obtained by subtracting area c (Figure 4d) from the total area, d, of the electrical heating curve. The ratio  $x/a$  is obtained by adding area A to area B (where  $B = d-c$ ) and dividing by the total area, e, (Figure 4b) due to the chemical reaction. Using the ratio  $x/a$  and the time at which it holds true, the first-order constant can be calculated from equation (17).

This procedure is repeated at other values of  $t$  to obtain a series of values for the rate constant, which can then be averaged.

### EXPERIMENTAL RESULTS

#### Phenyl Isocyanate Reactions

The kinetic data determined by chemical analysis are presented graphically in Figure 6, where  $\log$  rate is plotted against  $\log$  concentration of phenyl isocyanate for normal, iso, and secondary butyl alcohols at a series of temperatures. Only representative points appear in the figure. The rate constants for these reactions at a series of temperatures are presented in Table XIX. The tabulated rate constant is, in most cases, the average of two or more distinct determinations. The experimental error in the tabulated rate constants is estimated to be approximately 3%.

The rate constants calculated from the calorimetric data at 25°C. are given in Table XX.

For each of the three alcohols, the logarithm of the rate constant is plotted against the reciprocal absolute temperatures in Figure 7. The Arrhenius activation energies obtained from the slopes of these curves are 11.5, 11.8, and 12.5 kcal. mole<sup>-1</sup> for normal, iso, and secondary butyl alcohol respectively. The experimental points in Figures 7, 9, 11 and 13 are, in most cases, the average of two or more experiments.

TABLE XIX

Rate Constants for Phenyl Isocyanate Reactions

Temp. °C.	Rate Constant (l. mole <sup>-1</sup> sec. <sup>-1</sup> )		
	n-BuOH	i-BuOH	s-BuOH
25	4.57 x 10 <sup>-4</sup>	2.99 x 10 <sup>-4</sup>	1.44 x 10 <sup>-4</sup>
15	2.35 x 10 <sup>-4</sup>	1.54 x 10 <sup>-4</sup>	6.97 x 10 <sup>-5</sup>
5	1.15 x 10 <sup>-4</sup>	7.35 x 10 <sup>-5</sup>	3.14 x 10 <sup>-5</sup>

TABLE XX

Calorimetric Rate Constants for Phenyl Isocyanate Reactions

Alcohol	Calorimetric Rate Constant (l. mole <sup>-1</sup> sec. <sup>-1</sup> )	Analytical Rate Constant (l. mole <sup>-1</sup> sec. <sup>-1</sup> )
i-BuOH	2.98 x 10 <sup>-4</sup>	2.99 x 10 <sup>-4</sup>
s-BuOH	1.00 x 10 <sup>-4</sup>	1.44 x 10 <sup>-4</sup>

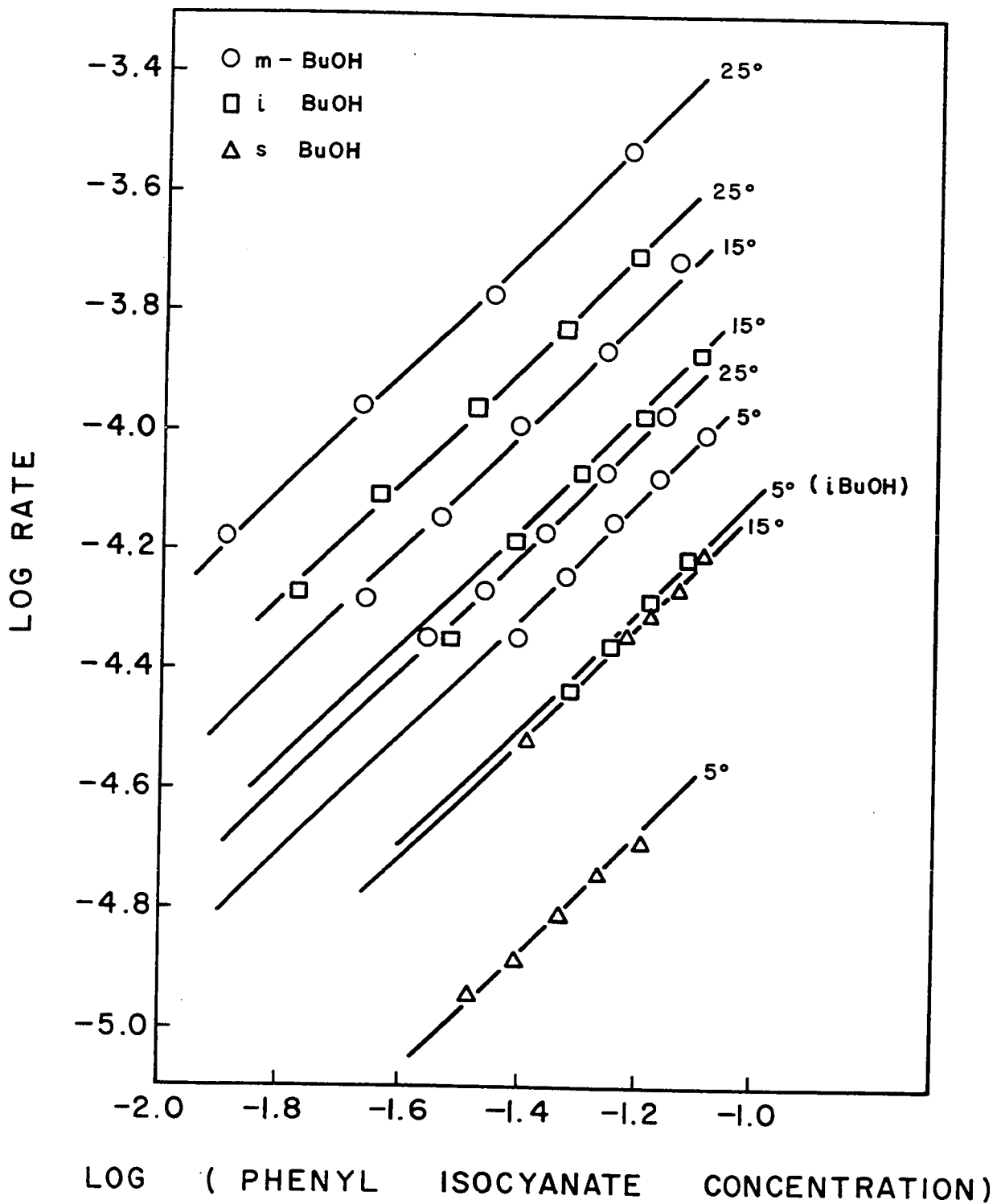

Figure 6 Phenyl isocyanate reactions: log rate plotted against log isocyanate concentration at 25°, 15°, and 5°C.

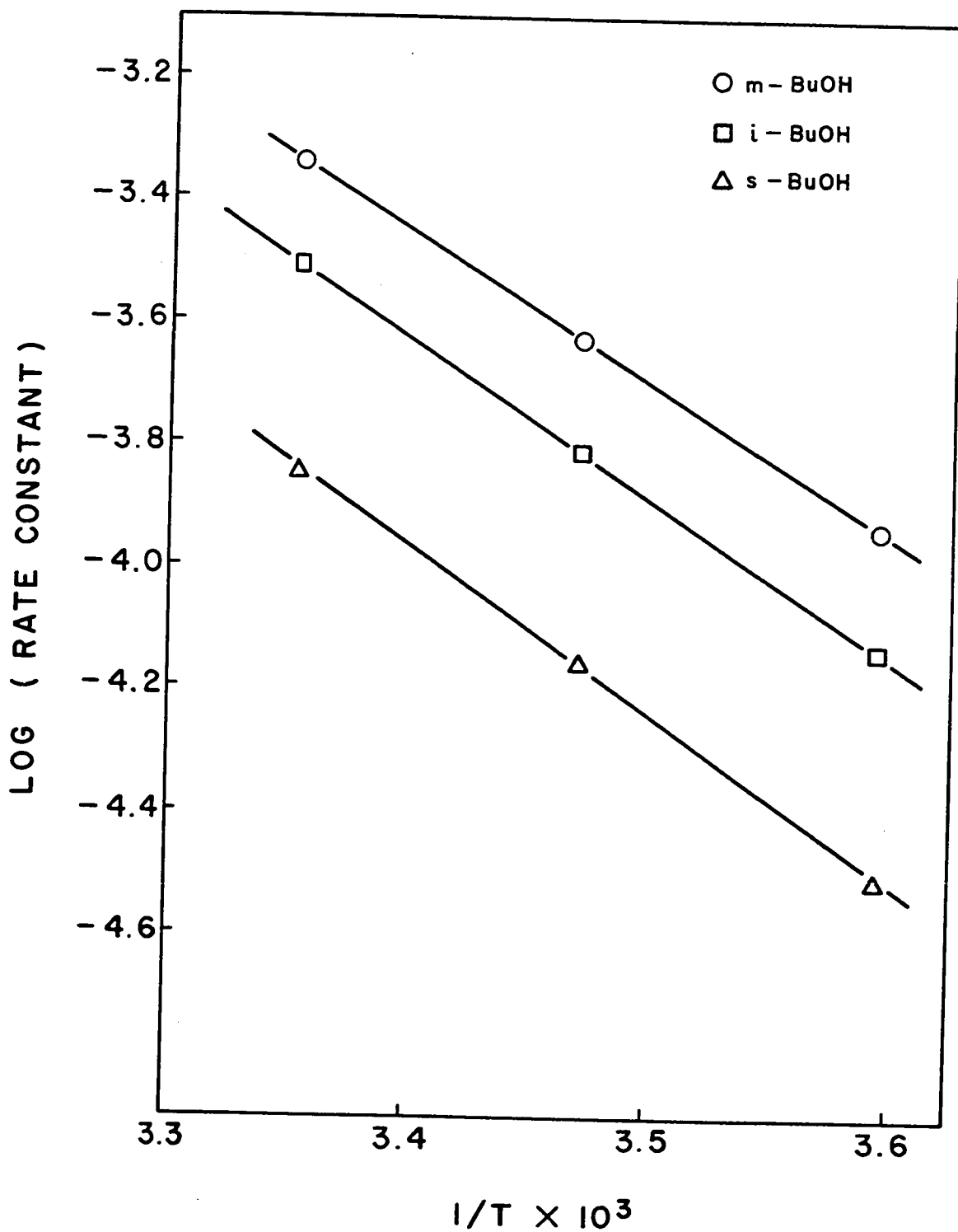

Figure 7 Phenyl isocyanate reactions: log rate constant plotted against the reciprocal of the absolute temperature

### o-Tolyl Isocyanate Reactions

Data for the o-tolyl isocyanate reactions with each alcohol at a series of temperatures are presented in Figure 8, where log rate is given as a function of log o-tolyl isocyanate concentration. Again only representative points are given. The rate constant for each reaction at each temperature is given in Table XXI.

Log rate constant plotted against the reciprocal of the absolute temperature is given in Figure 9. The Arrhenius activation energies, calculated from the slopes of these curves, are 12.9, 12.9, and 13.1 kcal. mole<sup>-1</sup> for normal, iso, and secondary butyl alcohols respectively.

TABLE XXI

Rate Constants for o-Tolyl Isocyanate Reactions

Temp. °C.	Rate Constant (l. mole <sup>-1</sup> sec. <sup>-1</sup> )		
	n-BuOH	i-BuOH	s-BuOH
35	9.01 x 10 <sup>-5</sup>	6.22 x 10 <sup>-5</sup>	3.05 x 10 <sup>-5</sup>
25	4.49 x 10 <sup>-5</sup>	3.07 x 10 <sup>-5</sup>	1.51 x 10 <sup>-5</sup>
15	2.08 x 10 <sup>-5</sup>	1.43 x 10 <sup>-5</sup>	6.82 x 10 <sup>-6</sup>

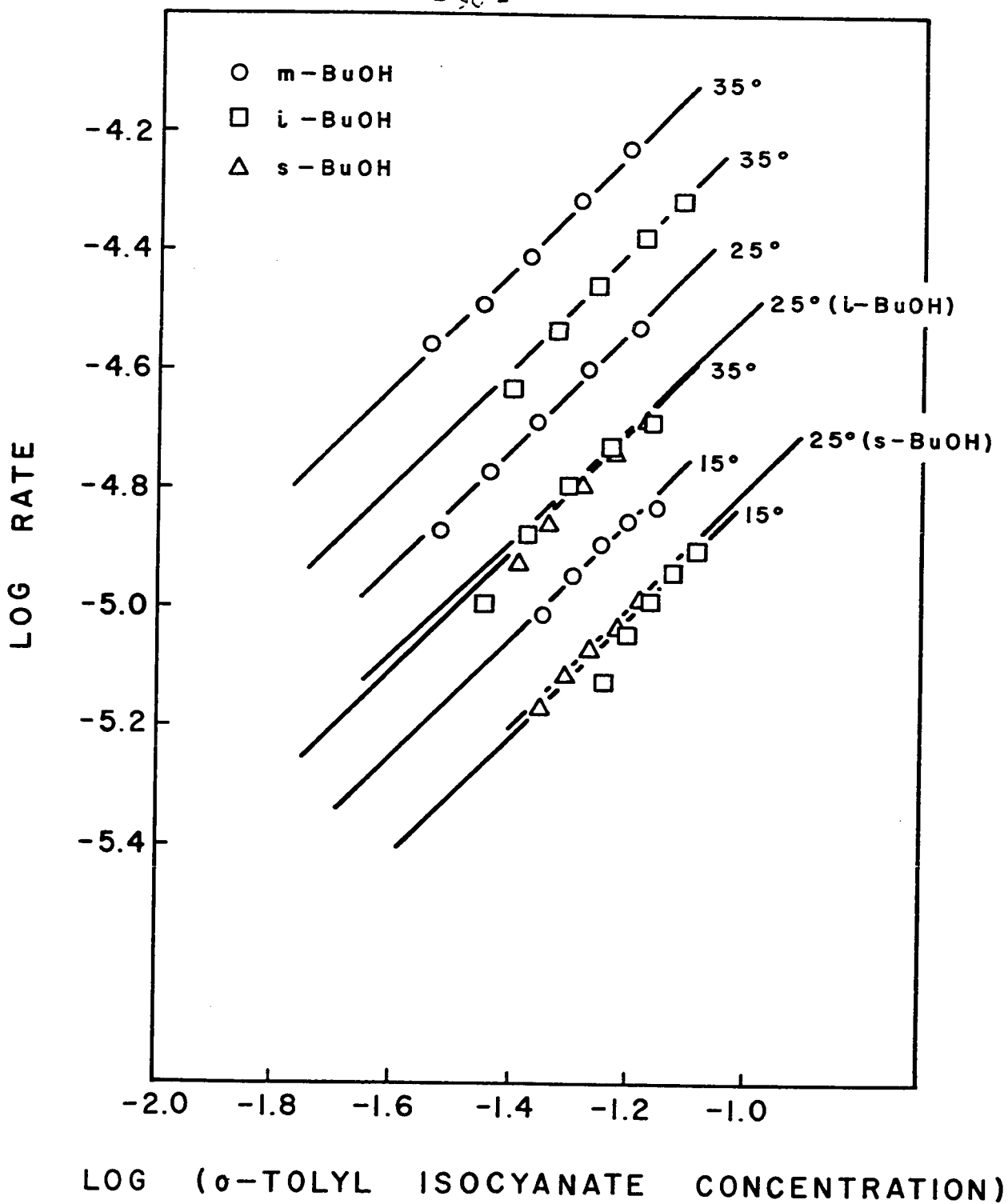

Figure 8 o-Tolyl isocyanate reactions: log rate plotted against log isocyanate concentration at 35°, 25°, and 15°C.

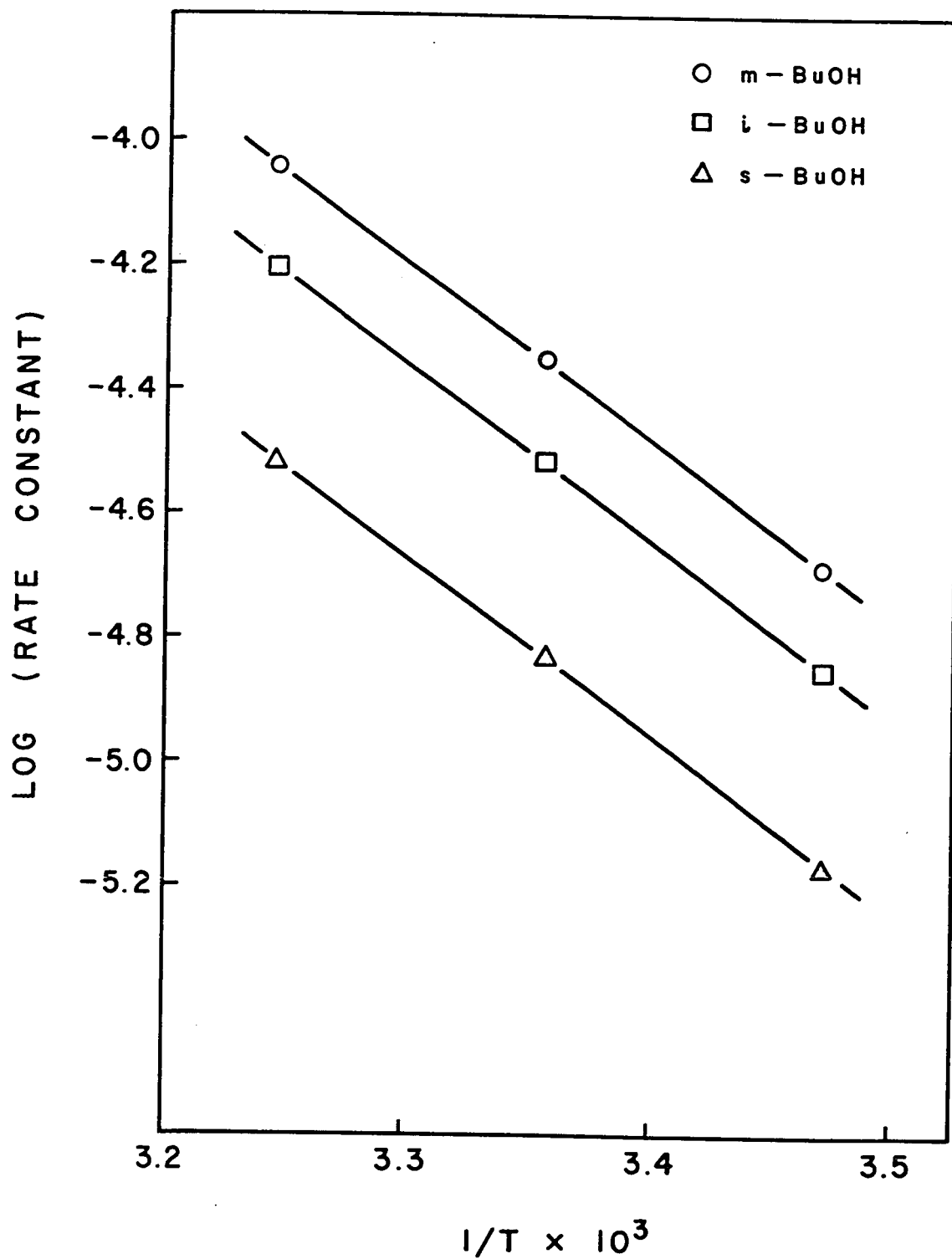

Figure 9 o-Tolyl isocyanate reactions: log rate constant plotted against the reciprocal of the absolute temperature

### m-Tolyl Isocyanate Reactions

The data for these reactions are given in Figure 10, where log rate is plotted against log m-tolyl isocyanate concentration. The second-order rate constant at each temperature for each reaction is presented in Table XXII.

The logarithm of the rate constant is plotted against the reciprocal of the absolute temperature in Figure 11. The Arrhenius activation energies, calculated from the slopes of these curves, are 11.7, 11.7, and 12.5 kcal. mole<sup>-1</sup> for normal, iso, and secondary butyl alcohol respectively.

Rate constants calculated calorimetrically are compared to those obtained by chemical analysis in Table XXIII. These apply at 25°C.

TABLE XXII

Rate Constants for m-Tolyl Isocyanate Reactions

Temp. °C.	Rate Constant (l. mole <sup>-1</sup> sec. <sup>-1</sup> )		
	n-BuOH	i-BuOH	s-BuOH
25	2.50 x 10 <sup>-4</sup>	1.73 x 10 <sup>-4</sup>	7.94 x 10 <sup>-5</sup>
15	1.29 x 10 <sup>-4</sup>	8.62 x 10 <sup>-5</sup>	4.06 x 10 <sup>-5</sup>
7	7.72 x 10 <sup>-5</sup>	5.48 x 10 <sup>-5</sup>	2.18 x 10 <sup>-5</sup>
0	4.04 x 10 <sup>-5</sup>	2.82 x 10 <sup>-5</sup>	1.25 x 10 <sup>-5</sup>

TABLE XXIII

Calorimetric Rate Constants for m-Tolyl Isocyanate Reactions

	Alcohol Calorimetric Rate Constant	Analytical Rate Constant
	(l. mole <sup>-1</sup> sec. <sup>-1</sup> )	(l. mole <sup>-1</sup> sec. <sup>-1</sup> )
n-BuOH	2.23 x 10 <sup>-4</sup>	2.50 x 10 <sup>-4</sup>
i-BuOH	1.57 x 10 <sup>-4</sup>	1.73 x 10 <sup>-4</sup>
s-BuOH	8.02 x 10 <sup>-5</sup>	7.94 x 10 <sup>-5</sup>

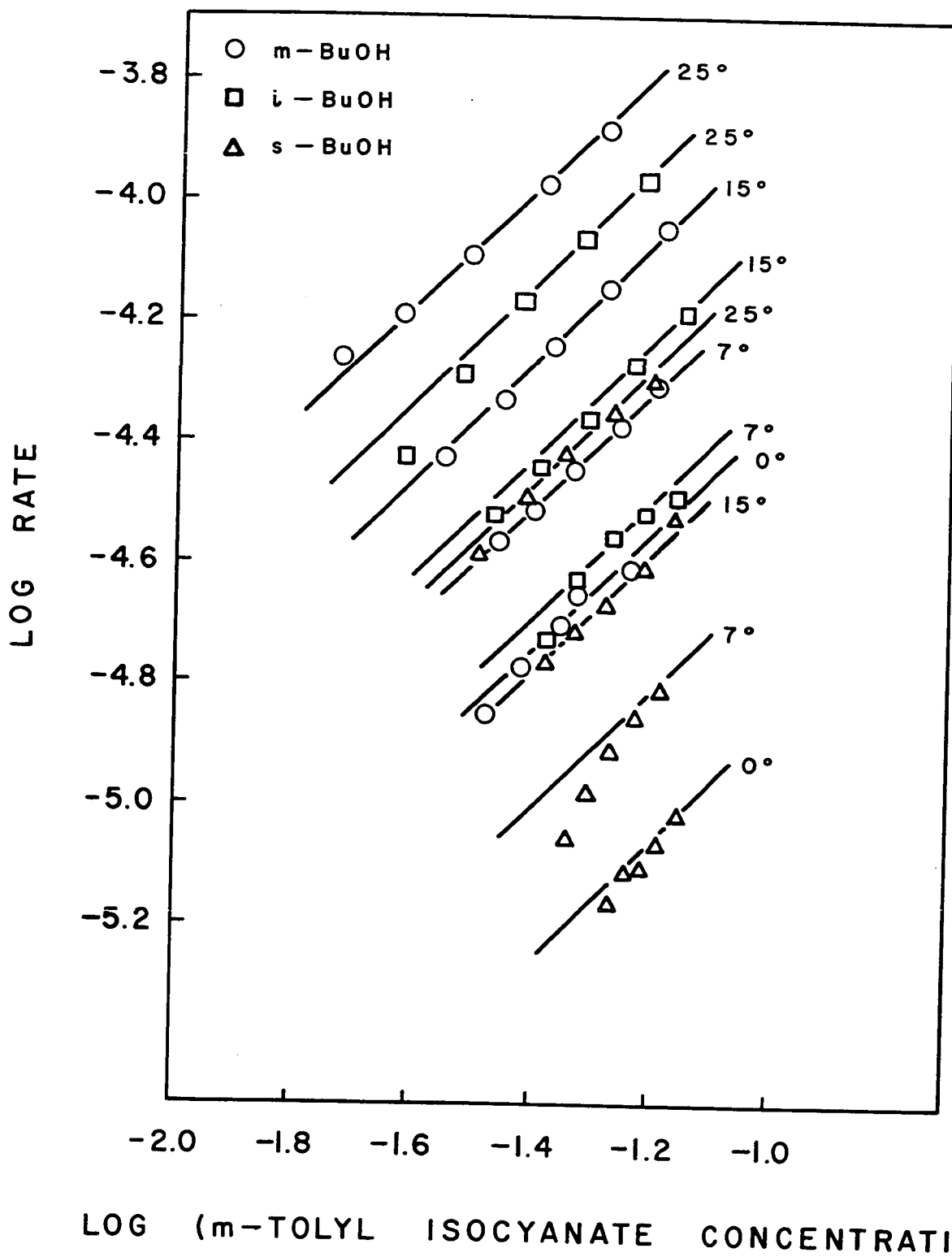

Figure 10 m-Tolyl isocyanate reactions: log rate plotted against log isocyanate concentration at 25°, 15°, 7°, and 0°C.

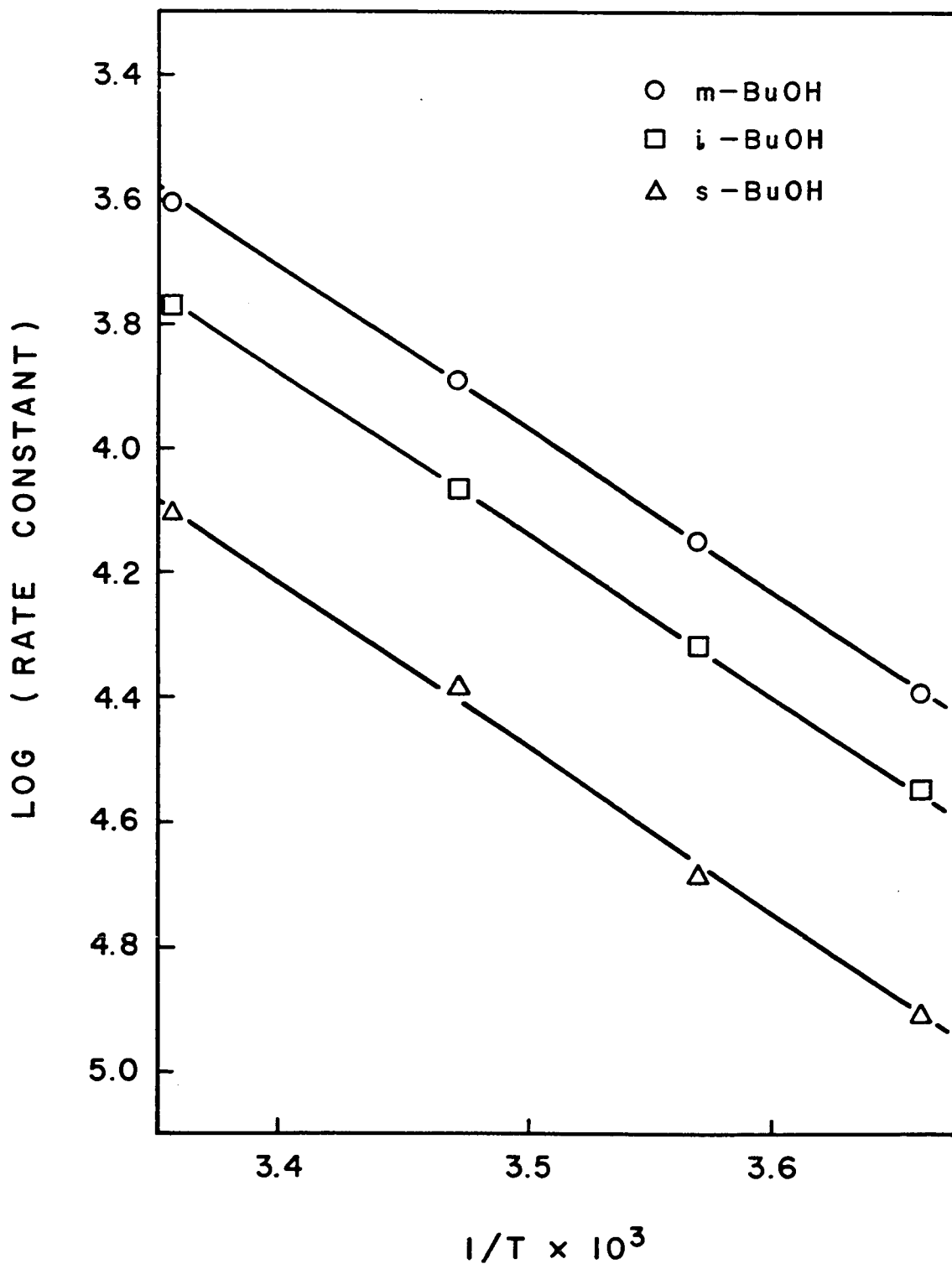

Figure 11 m-Tolyl isocyanate reactions: log rate constant plotted against the reciprocal of the absolute temperature.

### p-Tolyl Isocyanate Reactions

The data for the reactions of p-tolyl isocyanate with the three alcohols at a series of temperatures are given in Figure 12. The second-order rate constant at each temperature for each reaction is given in Table XXIV.

In Figure 13 the logarithm of the rate constant is plotted against the reciprocal of the absolute temperature. The Arrhenius activation energies for these reactions, obtained from the slopes of the curves in Figure 13, for normal, iso, and secondary butyl alcohols are 11.9, 12.0, and 12.3 kcal. mole<sup>-1</sup> respectively.

The second-order rate constants obtained calorimetrically are compared to those obtained by analysis in Table XXV.

### Calculated Results

The free energy of activation, the entropy of activation, and the frequency factor for each reaction has been calculated from the rate constant at 25°C. and the Arrhenius activation energy. The results of these calculations are presented in Table XXVI.

TABLE XXIV

Rate Constants for p-Tolyl Isocyanate Reactions

Temp. °C.	Rate Constant (l. mole <sup>-1</sup> sec. <sup>-1</sup> )		
	n-BuOH	i-BuOH	s-BuOH
25	2.46 x 10 <sup>-4</sup>	1.65 x 10 <sup>-4</sup>	7.64 x 10 <sup>-5</sup>
15	1.21 x 10 <sup>-4</sup>	8.21 x 10 <sup>-5</sup>	3.66 x 10 <sup>-5</sup>
0	3.86 x 10 <sup>-5</sup>	2.57 x 10 <sup>-5</sup>	1.13 x 10 <sup>-5</sup>

TABLE XXV

Calorimetric Rate Constants for p-Tolyl Isocyanate Reactions

	Alcohol Calorimetric Rate Constant	Analytical Rate Constant
	(l. mole <sup>-1</sup> sec. <sup>-1</sup> )	(l. mole <sup>-1</sup> sec. <sup>-1</sup> )
i-BuOH	1.84 x 10 <sup>-4</sup>	1.65 x 10 <sup>-4</sup>
s-BuOH	8.40 x 10 <sup>-5</sup>	7.64 x 10 <sup>-5</sup>

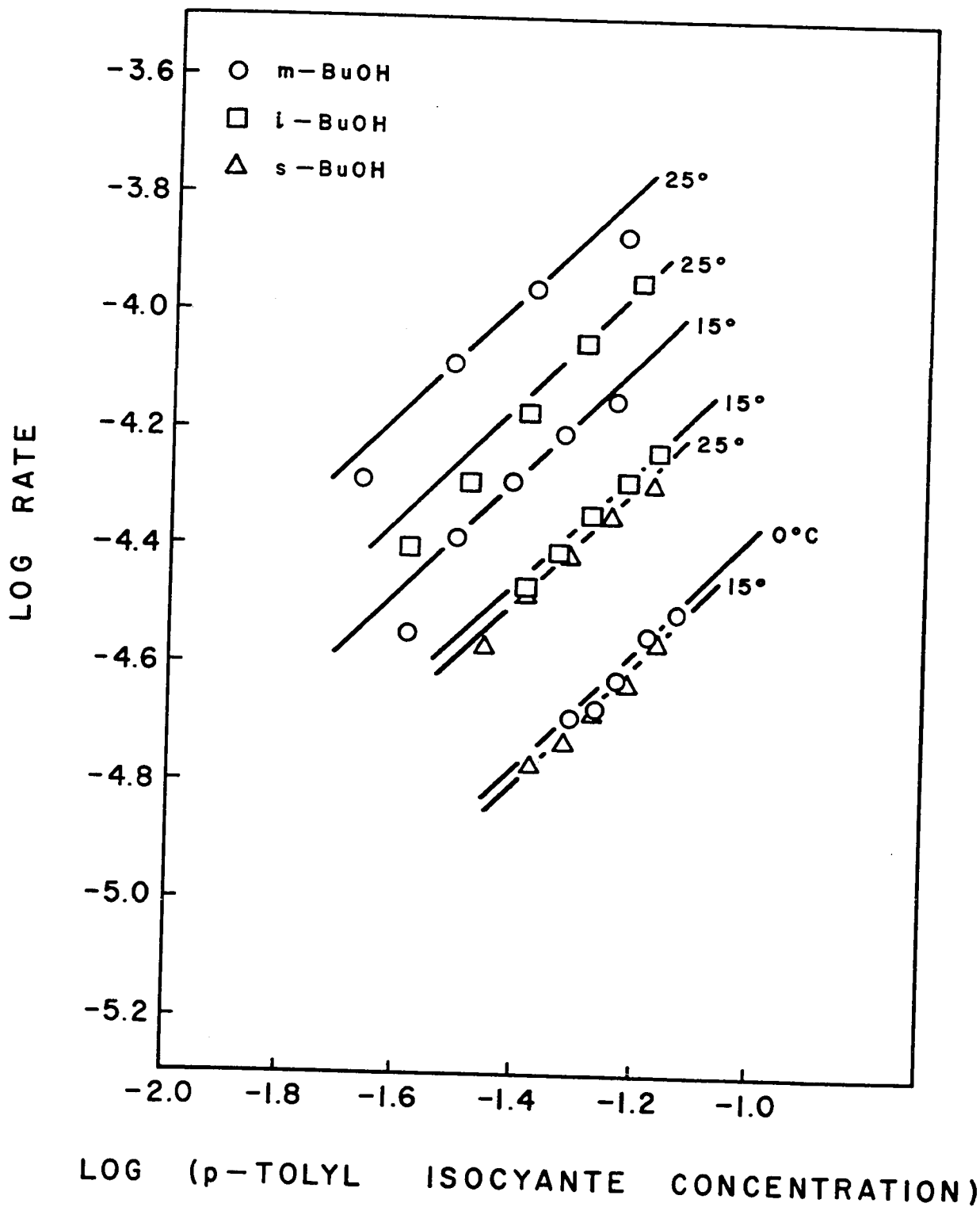

Figure 12 p-Tolyl isocyanate reactions: log rate plotted against log isocyanate concentration at 25°, 15°, and 0°C.

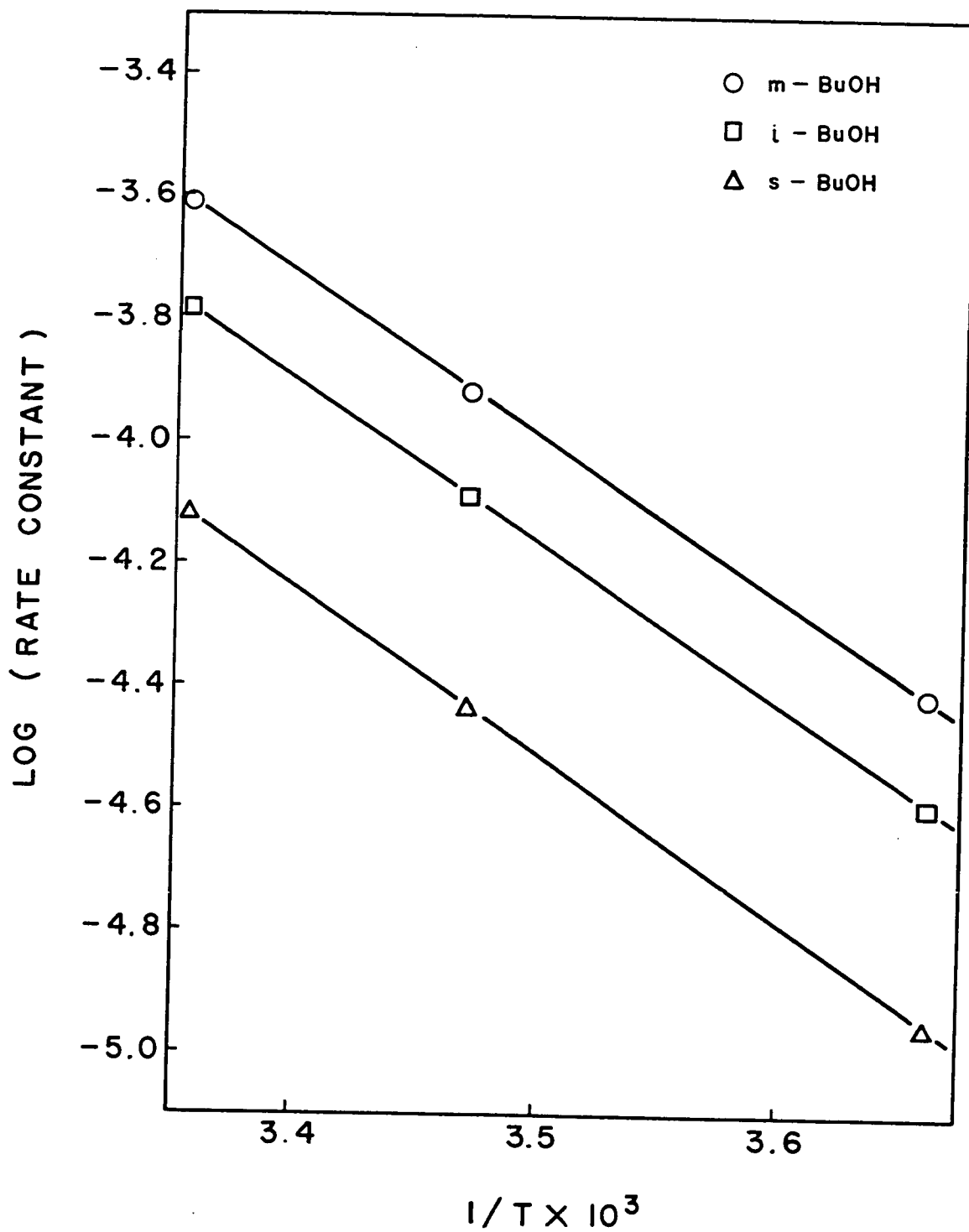

Figure 13 p-Tolyl isocyanate reactions: log rate constant plotted against the reciprocal of the absolute temperature.

TABLE XXVI

Calculated Results at 25°C.

Reaction	Rate Constant ( $\text{l. mole}^{-1} \text{sec.}^{-1}$ )	Act. ( $\text{kcal. mole}^{-1}$ )	Frequency Factor	$\Delta S^\ddagger$ (e.u.)	$\Delta G^\ddagger$ ( $\text{kcal. mole}^{-1}$ )
Isocyanate					
phenyl	$4.57 \times 10^{-4}$	11.5	$1.38 \times 10^5$	-36.9	21.9
phenyl	$2.99 \times 10^{-4}$	11.6	$1.33 \times 10^5$	-36.9	22.2
phenyl	$1.44 \times 10^{-4}$	12.5	$2.28 \times 10^5$	-35.9	22.6
o-tolyl	$4.49 \times 10^{-5}$	12.9	$1.32 \times 10^5$	-37.0	23.3
o-tolyl	$3.07 \times 10^{-5}$	12.9	$1.00 \times 10^5$	-37.5	23.5
o-tolyl	$1.50 \times 10^{-5}$	13.1	$0.65 \times 10^5$	-38.4	24.0
m-tolyl	$2.50 \times 10^{-4}$	11.7	$1.05 \times 10^5$	-37.4	22.3
m-tolyl	$1.73 \times 10^{-4}$	11.7	$0.72 \times 10^5$	-38.1	22.5
m-tolyl	$7.95 \times 10^{-5}$	12.5	$1.19 \times 10^5$	-37.2	23.0
p-tolyl	$2.46 \times 10^{-4}$	11.9	$1.44 \times 10^5$	-36.8	22.3
p-tolyl	$1.65 \times 10^{-4}$	12.0	$1.06 \times 10^5$	-37.4	22.5
p-tolyl	$7.64 \times 10^{-5}$	12.3	$0.84 \times 10^5$	-37.9	23.0

## DISCUSSION OF THE RESULTS

The rate constants obtained from the calorimetric data using the method suggested by Baumgartner and Duhaut are discussed first, followed by a discussion of the kinetics of the alcohol-isocyanate reactions.

### Calorimetric Rate Constants

For the sake of convenience the calorimetric rate constants are summarized and compared to the analytical rate constants for a series of reactions in Table XXVII.

It is seen from Table XXVII that all the rate constants determined calorimetrically are within 10 percent of those determined by chemical analysis. These results are as good as can be expected, since there are important sources of error in determining the calorimetric rate constant. Attempts were made to correct the results for the time lag between an event occurring in the reaction cell, and the E. M. F. produced by this event appearing as a signal on the recorder. Attempts were also made to correct for the rate increase due to the temperature rise in the reaction cell, due to the heat of reaction.

The lapse in time between a heat change occurring in the reaction cell, and the appearance of this change as a signal on the recorder, is estimated to be approximately 50 to 100 seconds. This time lag, which is really an error

TABLE XXVII

Summary of Calorimetric Rate Constants at 25°C.

<u>Alcohol</u>	<u>Isocyanate</u>	Rate Constants	Rate Constants	<u>Difference %</u>
		(l. mole <sup>-1</sup> sec. <sup>-1</sup> ) <u>Calorimetric</u>	(l. mole <sup>-1</sup> sec. <sup>-1</sup> ) <u>Analytical</u>	
i-butyl	phenyl	2.98 x 10 <sup>-4</sup>	2.99 x 10 <sup>-4</sup>	0.3
s-butyl	phenyl	1.60 x 10 <sup>-4</sup>	1.44 x 10 <sup>-4</sup>	-10.0
n-butyl	m-tolyl	2.28 x 10 <sup>-4</sup>	2.50 x 10 <sup>-4</sup>	10.0
i-butyl	m-tolyl	1.57 x 10 <sup>-4</sup>	1.73 x 10 <sup>-4</sup>	10.0
s-butyl	m-tolyl	8.02 x 10 <sup>-5</sup>	7.94 x 10 <sup>-5</sup>	-0.7
i-butyl	p-tolyl	1.84 x 10 <sup>-4</sup>	1.65 x 10 <sup>-4</sup>	-10.4
s-butyl	p-tolyl	8.40 x 10 <sup>-5</sup>	7.64 x 10 <sup>-5</sup>	-9.0

in the measurement of the time, will introduce a considerable error into the calculation of the rate constant, particularly during the initial stages of the reaction. In order to see if an empirical correction could be applied to the time measurement the following procedure was employed. It was assumed that the rate constant measured by chemical analysis was correct. This rate constant was then divided by  $\ln(a/a-x)$  as determined from the calorimetric charts, to obtain a corrected time. The difference between the corrected time, and the time read from the charts was found; this difference was plotted as a function of time. A few typical time versus time difference curves are given in Figure 14. Although the resulting curves are straight lines, they have neither the same slope, nor the same intercept. It is not possible, therefore, to apply a simple empirical correction to the time read from the calorimeter charts.

A second source of error is that the temperature of the reaction cell increases as the reaction proceeds, resulting in a small increase in the rate constant. However, it is seen from Table XXVII that some of the calorimetric rate constants are larger than the corresponding rate constant found by chemical analysis, and some are smaller. It does not, therefore, seem possible to apply a correction to the rate constant based on this source of error.

The reason for the failure of an empirical time lag correction may be due to small differences in thermal

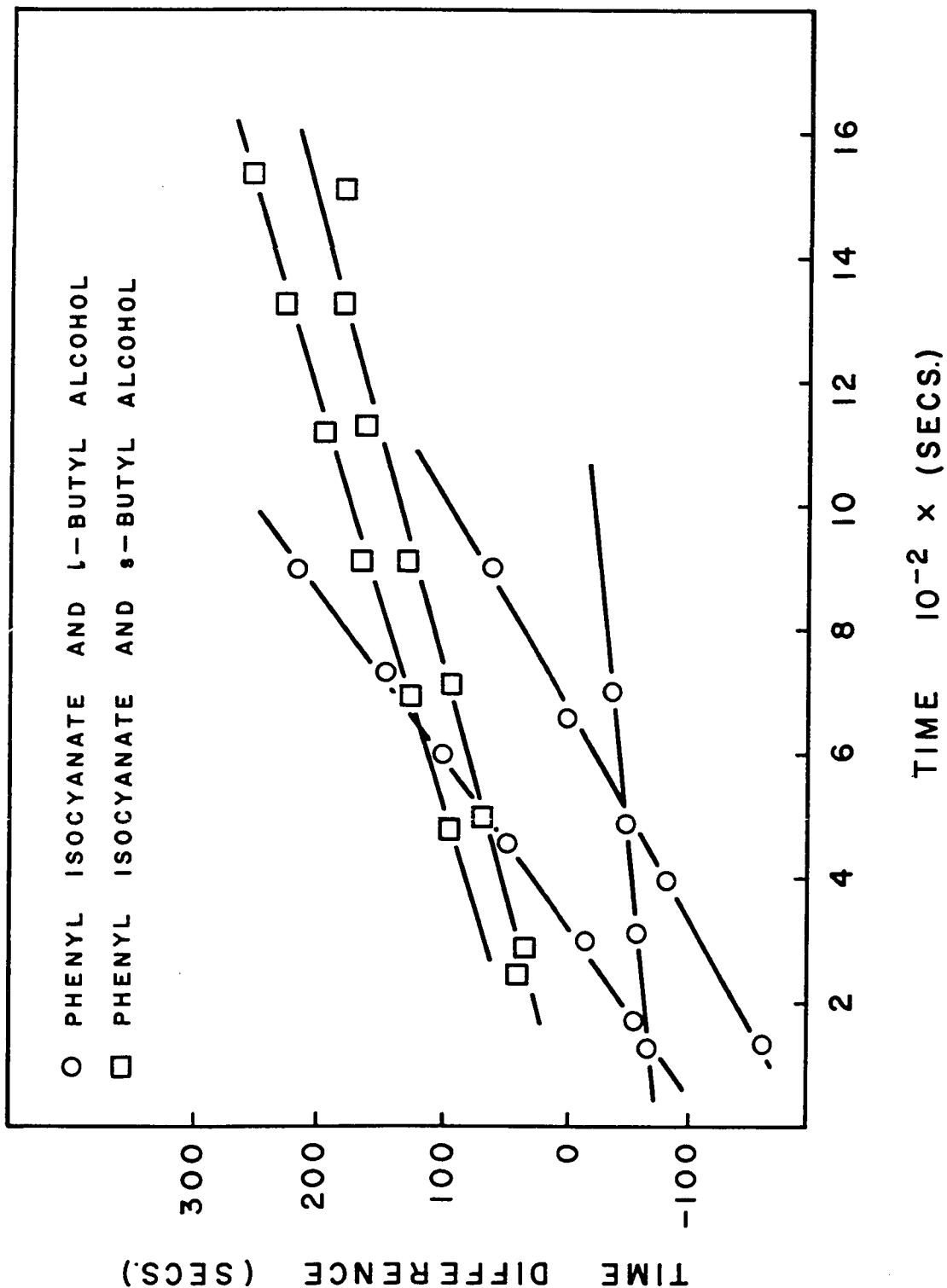

Figure 14 Calorimetric calculations: time versus time difference curves.

conductivity between the reaction cell and the calorimeter from one run to the next. These differences would cause changes in the magnitude of the time lag.

### The Kinetics of Alcohol-Isocyanate Reactions

The experimental results are in accord with previously determined data concerning reactions of this type, and fit the mechanism suggested by Baker and co-workers (49, 50, 51). Most of the reactions exhibit a deviation from psuedo first-order kinetics, as is seen from Figures 6, 8, 10, and 12. These deviations are attributed to the catalysis of the reaction by the product urethane, acting as a weak base.

The only previous work which is directly comparable to the results obtained here is that of Dyer et al. (41), who measured the reaction rates and activation energies of phenyl isocyanate reacting with normal and secondary butyl alcohols in xylene solution. They report activation energies of 8.1 and 9.9 kcal. mole<sup>-1</sup> for normal and secondary butyl alcohols, respectively. The values obtained here are 11.5 and 12.5 kcal. mole<sup>-1</sup> respectively. This change in activation energy confirms the observations of Baker that the activation energy increases as the ratio of alcohol to isocyanate increases. The reactions reported here were carried out in a large excess of alcohol, while Dyer's work was in xylene solution.

In Figure 14 the Arrhenius activation energy has been plotted as a function of the free energy of activation. It is seen from the figure that there is a general tendency for the activation energy to increase as the free energy of activation increases. This type of relationship shows that the entropy of activation is very approximately the same for each reaction, as is evident from the values of the activation entropy in Table XXVI. This means that the activation entropy is independent of the position of the isocyanate group on the aromatic ring; that is, the solvation and charge separation of the activated complex are similar in each case.

The activation entropies for the reactions investigated provide a large measure of support for the Baker mechanism. Usually large negative activation entropies are an indication of an activated complex having oppositely charged centers, separated from each other. The activated complex of Baker's mechanism is just such a species; it is doubtful that the formation of an alcohol-solvent, or alcohol-alcohol complex would produce such a large negative activation entropy.

It is of interest to note, at least for the reaction between n-butyl alcohol and phenyl isocyanate, that the free energy of activation appears to be independent of the reaction conditions, whereas the energy and entropy of activation are

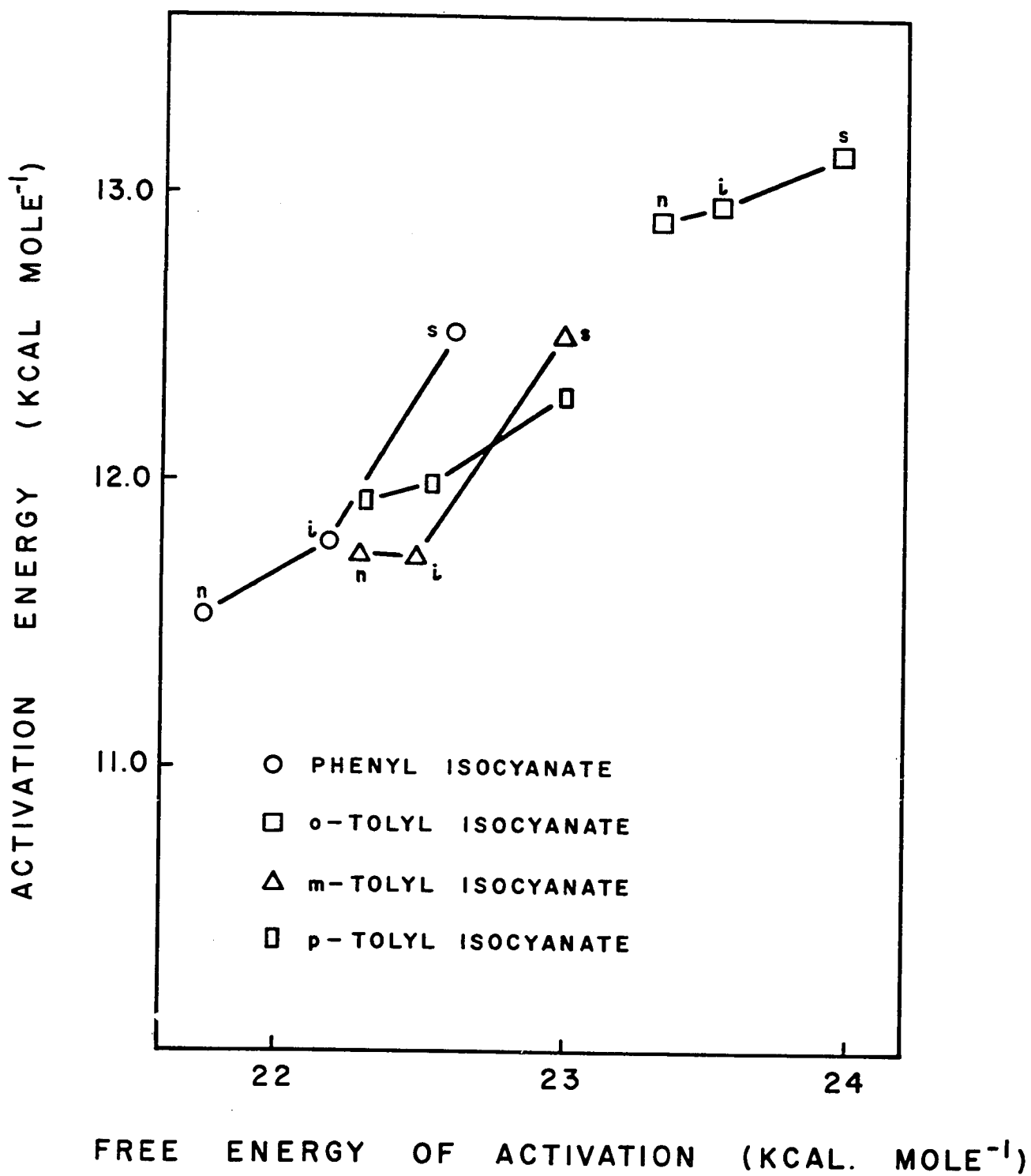

Figure 15 Arrhenius activation energy as a function of the free energy of activation.

strongly dependent on them. Dyer et al. (41) report values of -48 e.u., 7.5 and 22.0 kcal. mole<sup>-1</sup> for the entropy, energy, and free energy of activation respectively. These values apply to the uncatalysed reaction in xylene solution at 25°C. For the same reaction in toluene catalysed by triethyl amine Burkus and Eckert (54) report -60.7 e.u., 3.1 and 21.2 kcal. mole<sup>-1</sup> for entropy, energy, and free energy of activation. The values found in this work are -56.9 e.u., 10.9 and 21.9 kcal. mole<sup>-1</sup>. The entropy of activation decreases as the energy of activation decreases, in agreement with Baker's findings. The increase in the activation energy as the alcohol concentration increases is probably an indication that more and more hydrogen bonds must be ruptured before the activated complex can form. The increase in the entropy of activation probably indicates a decreasing amount of solvent rearrangement as the activated complex is formed. That is, the reactants are probably already well solvated with alcohol, and the formation of the activated complex requires solvent rearrangement, rather than the addition of new molecules to the solvation shell of the activated complex. The lower entropy of activation for the amine catalysed reaction is probably an indication that the activated complex contains the amine molecule.

The experimental work of Ephraim et al. does not give adequate support to the mechanism they have proposed. In addition, Baker et al. have given evidence to support

their claim that the reaction does not proceed by way of the mechanism suggested by Ephraim et al. The dielectric constant-log rate work of Ephraim et al. is of doubtful significance because of the extreme dependence of the reaction rate on the polarity of the solvent and on its steric properties. In conclusion it seems best not to attach much significance to the data of Ephraim et al., and none to their conclusions as to mechanism.

CLAIMS TO ORIGINAL RESEARCH

1. A bond-energy scheme permitting calculation of certain thermodynamic properties of the thiaalkanes, the alkanethiols, and the dithiaalkanes has been devised.
2. A new treatment of the bond-energy scheme for alcohols, ethers, and alkyl peroxides has been devised.
3. The heat of reaction for fifteen alcohol-isocyanate reactions has been measured at 25°C.
4. An estimate of the heat of formation of certain urethanes and isocyanates has been made, using heats of reaction data measured here, and data obtained from the literature.
5. Kinetic rate constants have been successfully calculated using data obtained from heat of reaction measurements.
6. The kinetics of twelve alcohol-isocyanate reactions in a large excess of alcohol have been studied, and the results shown to be in agreement with a mechanism given elsewhere.

REFERENCES

- (1) F. W. Clarke. Proc. Wash. Acad. Science. 5, (1903).
- (2) W. Swietoslawski. J. Am. Chem. Soc. 42, 1312 (1920).
- (3) M. S. Kharasch and B. Shur. J. Phys. Chem. 29, 629 (1925).
- (4) M. S. Kharasch. J. Research Nat. Bur. Standards. 2, 359 (1929).
- (5) L. Pauling. The Nature of the Chemical Bond. Cornell Univ. Press, Ithaca, N. Y. 1939.
- (6) V. M. Tatevskii. Doklady Akad. Nauk. S.S.S.R. 75, 819 (1950).
- (7) V. M. Tatevskii, V. V. Korobov, and E. A. Mendzheretskii. Doklady Akad. Nauk. S.S.S.R. 74, 743 (1950).
- (8) V. M. Tatevskii. Zhur. Fiz. Khim. (2) 25, 241 (1951).
- (9) H. J. Bernstein. J. Chem. Phys. 20, 263 (1952).
- (10) K. J. Laidler. Can. J. Chem. 34, 626 (1956).
- (11) E. G. Lovering and K. J. Laidler. Can. J. Chem. 38, 2367 (1960).

- (12) T. L. Cottrell. The Strengths of Chemical Bonds. Butterworths Scientific Publications, London. 1958. p. 155.
- (13) U. S. National Bureau of Standards. Selected values of chemical thermodynamic properties. Ser. I. Washington. 1952.
- (14) J. P. McCullough, W. N. Hubbard, F. R. Frow, I. A. Hossenlopp, and G. Waddington. J. Am. Chem. Soc. 79, 561 (1957).
- (15) W. D. Scott and J. P. McCullough. J. Am. Chem. Soc. 80, 3547 (1958).
- (16) R. E. Pennington, D. W. Scott, H. L. Finke, J. P. McCullough, J. F. Messerly, I. A. Hossenlopp, and G. Waddington. J. Am. Chem. Soc. 78, 3266 (1956).
- (17) J. P. McCullough, H. L. Finke, D. W. Scott, M. E. Cross, J. F. Messerly, R. E. Pennington, and G. Waddington. J. Am. Chem. Soc. 76, 4798 (1954).
- (18) D. W. Scott, G. B. Guthrie, J. P. McCullough, and G. Waddington. J. Chem. & Eng. Data Ser. 4, No. 3, 246 (1958).
- (19) W. N. Hubbard, W. D. Scott, and G. Waddington. J. Phys. Chem. 62, 614 (1958).

- (20) D. W. Scott, H. L. Finke, W. N. Hubbard, J. P. McCullough, G. D. Oliver, M. E. Gross, C. Katz, K. D. Williamson, G. Waddington, and H. M. Huffman. J. Am. Chem. Soc. 79, 1062 (1957).
- (21) J. P. McCullough, H. L. Finke, D. W. Scott, R. E. Pennington, M. E. Gross, J. F. Messerly, and G. Waddington. J. Am. Chem. Soc. 80, 4786 (1958).
- (22) D. W. Scott, J. P. McCullough, J. F. Messerly, R. E. Pennington, I. A. Hossenlopp, H. L. Finke, and G. Waddington. J. Am. Chem. Soc. 80, 55 (1958).
- (23) J. P. McCullough, D. W. Scott, H. L. Finke, W. N. Hubbard, M. E. Gross, C. Katz, R. E. Pennington, J. F. Messerly, and G. Waddington. J. Am. Chem. Soc. 75, 1818 (1953).
- (24) W. D. Scott, H. L. Finke, W. N. Hubbard, J. P. McCullough, G. D. Oliver, M. E. Gross, C. Katz, K. D. Williamson, G. Waddington, and H. M. Huffman. J. Am. Chem. Soc. 74, 4656 (1952).
- (25) J. P. McCullough, H. L. Finke, J. F. Messerly, R. E. Pennington, I. A. Hossenlopp, and G. Waddington. J. Am. Chem. Soc. 77, 6119 (1955).
- (26) W. N. Hubbard, E. Katz, and G. Waddington. J. Phys. Chem. 58, 142 (1954).

- (27) S. Sunner. Acta Chem. Scand. 9, 837 (1955).
- (28) U. S. National Bureau of Standards. Selected values of chemical thermodynamic properties. Ser. I. Washington. 1952.
- (29) G. S. Parks and K. E. Manchester. I.U.P.A.C. Sub-Commission on Experimental Thermochemistry. Thermochemical Bull. No. 2, March, 1958; the value is quoted with the kind permission of Professor G. S. Parks.
- (30) J. Tjebbes. Acta Chem. Scand. 14, 180 (1960).
- (31) J. H. Raley, F. F. Rust, and W. E. Vaughan. J. Am. Chem. Soc. 70, 28 (1948).
- (32) R. E. Rebertus and K. J. Laidler. J. Chem. Phys. 20, 574 (1952).
- (33) E. A. Skinner and A. Spilner. Trans. Far. Soc. 56, 1776 (1960).
- (34) P. Lemoult. Ann. chim. et phys. Series VII, 16, 338 (1899).
- (35) A. Schmidt. Z. ges. Schiess- u. Sprengstoffw. 29, 259 (1934).
- (36) E. Calvet and H. Prat. Microcalorimetric. Masson and Cie. Paris. 1956.

- (37) R. W. Attree, E. L. Cushing, J. A. Ladd, and J. J. Pieroni. *Rev. Sc. Inst.* 29, 491 (1958).
- (38) A. L. Albert. *Electronics and Electronic Devices*. The MacMillan Co. New York. 1957. p. 480.
- (39) Y. Ueda. *Science Reports. Tohoku Imp. Univ.* I 22, 879 (1933).
- (40) J. Timmermans. *Physico-Chemical Constants of Pure Organic Compounds*. Elsevier Publishing Co. Amsterdam. 1950. p. 318, p. 320, p. 322.
- (41) E. Dyer, H. A. Taylor, S. J. Mason, and J. Samson. *J. Am. Chem. Soc.* 71, 4106 (1949).
- (42) *Beilsteins Handbuch der Organischen Chemie*. Vierte Auflage. Zweites Ergänzungswerk. Springer-Verlag. Berlin. 1950 Vol. 12 II p. 444, p. 511. Vol. 12, p. 321.
- (43) K. J. Laidler. *Chemical Kinetics*. McGraw-Hill Book Co. Inc. New York. 1950. p. 12.
- (44) H. Hartridge and F. J. W. Roughton *Proc. Roy. Soc.* A104, 376 (1923).
- (45) R. P. Bell and J. C. Clunie. *Proc. Roy. Soc.* A212, 16 (1952)
- (46) P. Baumgartner and P. Duhaut. *Bull. soc. chim France*. 1187 (1960).

- (47) T. L. Davis and M. C. Farnum. *J. Am. Chem. Soc.* 56, 883 (1934).
- (48) H. E. Stagg. *The Analyst.* 71, 557 (1946).
- (49) J. W. Baker and J. B. Holdsworth. *J. Chem. Soc.* 713 (1947).
- (50) J. W. Baker and J. Gaunt. *J. Chem. Soc.* 9, 19, 27 (1949).
- (51) J. W. Baker, M. M. Davies, and J. Gaunt. *J. Chem. Soc.* 24 (1949).
- (52) S. Ephraim, A. E. Woodward, and F. B. Mesrobian. *J. Am. Chem. Soc.* 80, 1326 (1958).
- (53) I. C. Kogon. *J. Org. Chem.* 24, 438 (1959).
- (54) J. Burkus and C. F. Eckert. *J. Am. Chem. Soc.* 80, 5948 (1958).
- (55) M. Sato. *J. Am. Chem. Soc.* 82, 3893 (1960).
- (56) I. M. Kolthoff and E. B. Sandell. *Textbook of Quantitative Inorganic Analysis.* The Macmillan Co. New York. 1953. p. 307.