

# NOTE TO USERS

Page(s) not included in the original manuscript and are unavailable from the author or university. The manuscript was scanned as received.

iv - v

This reproduction is the best copy available.

**UMI**®





uOttawa

L'Université canadienne  
Canada's university

**FACULTÉ DES ÉTUDES SUPÉRIEURES  
ET POSTDOCTORALES**



**FACULTY OF GRADUATE AND  
POSTDOCTORAL STUDIES**

**Suruz Miah**

AUTEUR DE LA THÈSE / AUTHOR OF THESIS

**M.A.Sc. (Electrical Engineering)**

GRADE / DEGREE

**School of Information Technology**

FACULTÉ, ÉCOLE, DÉPARTEMENT / FACULTY, SCHOOL, DEPARTMENT

**Autonomous Mobile Robot Navigation Using RFID Technology**

TITRE DE LA THÈSE / TITLE OF THESIS

**Prof. W. Gueaieb**

DIRECTEUR (DIRECTRICE) DE LA THÈSE / THESIS SUPERVISOR

CO-DIRECTEUR (CO-DIRECTRICE) DE LA THÈSE / THESIS CO-SUPERVISOR

**EXAMINATEURS (EXAMINATRICES) DE LA THÈSE / THESIS EXAMINERS**

**Prof. A. Boukerche**

**Prof. P.X. Liu**

**Gary W. Slater**

Le Doyen de la Faculté des études supérieures et postdoctorales / Dean of the Faculty of Graduate and Postdoctoral Studies

# Autonomous Mobile Robot Navigation Using RFID Technology

by

Md. Suruz Miah

Thesis submitted to the  
Faculty of Graduate and Postdoctoral Studies  
In partial fulfillment of the requirements  
For the M.A.Sc. degree in  
Electrical and Computer Engineering

School of Information Technology and Engineering  
Faculty of Engineering  
University of Ottawa

© Md. Suruz Miah, Ottawa, Canada, 2007



Library and  
Archives Canada

Bibliothèque et  
Archives Canada

Published Heritage  
Branch

Direction du  
Patrimoine de l'édition

395 Wellington Street  
Ottawa ON K1A 0N4  
Canada

395, rue Wellington  
Ottawa ON K1A 0N4  
Canada

*Your file* *Votre référence*  
*ISBN: 978-0-494-49250-5*  
*Our file* *Notre référence*  
*ISBN: 978-0-494-49250-5*

**NOTICE:**

The author has granted a non-exclusive license allowing Library and Archives Canada to reproduce, publish, archive, preserve, conserve, communicate to the public by telecommunication or on the Internet, loan, distribute and sell theses worldwide, for commercial or non-commercial purposes, in microform, paper, electronic and/or any other formats.

The author retains copyright ownership and moral rights in this thesis. Neither the thesis nor substantial extracts from it may be printed or otherwise reproduced without the author's permission.

**AVIS:**

L'auteur a accordé une licence non exclusive permettant à la Bibliothèque et Archives Canada de reproduire, publier, archiver, sauvegarder, conserver, transmettre au public par télécommunication ou par l'Internet, prêter, distribuer et vendre des thèses partout dans le monde, à des fins commerciales ou autres, sur support microforme, papier, électronique et/ou autres formats.

L'auteur conserve la propriété du droit d'auteur et des droits moraux qui protègent cette thèse. Ni la thèse ni des extraits substantiels de celle-ci ne doivent être imprimés ou autrement reproduits sans son autorisation.

---

In compliance with the Canadian Privacy Act some supporting forms may have been removed from this thesis.

Conformément à la loi canadienne sur la protection de la vie privée, quelques formulaires secondaires ont été enlevés de cette thèse.

While these forms may be included in the document page count, their removal does not represent any loss of content from the thesis.

Bien que ces formulaires aient inclus dans la pagination, il n'y aura aucun contenu manquant.

  
**Canada**

## Abstract

Navigation techniques are of a paramount importance in the field of mobile robotics. They are employed in many contexts in indoor and outdoor environments such as delivering payloads in a dynamic environment, building safety, security, building measurement, research, and driving on highways. Skilled navigation in mobile robotics usually requires solving two problems, determining the position of the robot, and selecting a motion control strategy. Moreover, when no prior knowledge of the environment is available, the problem becomes even more difficult, as the robot has to build a map of its surroundings as it moves. These three tasks ought to be solved in conjunction, since they depend on each other.

This dissertation explores the design of a cost-effective and modular navigation method for mobile robots. In particular, we will look at the process of navigating a mobile robot using the emerging RFID technology. A successful realization of this process has been addressed with two separate navigation modules. Each module presents a separate navigation algorithm for a mobile robot. In the first module, a customized RFID reader is mounted on the robot. The information provided by the reader will then be used for navigation. On the contrary, in the second module, custom-made RFID tags are attached at different locations in the navigation environment (on the ceiling of a building, posts, for instance). The position of the mobile robot is then determined based on the information provided by the tags in the robot's operating region. The angle between the robot's current direction and the target tag is used to provide actions to the actuators. In both modules, the algorithms take advantage of using analogue features of the RFID system instead of relying only on the binary tag number which conventional RFID-driven applications depend on.

## Acknowledgements

I would like to express my sincere gratitude to my thesis supervisor, Dr. Wail Gueaieb, for all of his insight, support, feedback, and guidance throughout my master's studies. I also thank my supervisor for guiding me towards academic as well as personal success. The work described herein could not have been done successfully without extensive ideas, help, and advice from him. He helped me to stay on track whenever I began researching in fruitless directions (which happened often!). He also encouraged me to go and present parts of my work in two international conferences.

Finally, I would like to give my sincere thanks to my beloved parents and all other family members for their support throughout my graduate studies. I would also like to offer best wishes to my younger brother, Md. Sawkat Hossain, for inspiring me to study abroad and for taking care of my parents in the absence of myself back home. I am also grateful to my new and very close relatives as well as to all of my friends who helped me either with suggestions or with positive affirmation. I would like to thank my special friend, Md. Shahjahan Mia, Software Engineer, Bangladesh Internet Press Limited, Dhaka, Bangladesh, for encouraging, helping, and sharing various situations with me during my studies abroad. I am also grateful to my friends, Nazish Irfan and Fazel Keshtkar, Ph.D. researchers, University of Ottawa, who helped me during my critical moments during my Masters studies.

# Contents

<b>1</b>	<b>Introduction</b>	<b>2</b>
1.1	Motivation . . . . .	3
1.2	Thesis Objectives and Contributions . . . . .	3
1.3	Thesis Outline . . . . .	4
<b>2</b>	<b>Literature Review</b>	<b>5</b>
2.1	Introduction . . . . .	5
2.2	Dead-reckoning-based Navigation . . . . .	8
2.3	Landmark-based Navigation . . . . .	10
2.3.1	Artificial Landmark-based Navigation . . . . .	10
2.3.2	Natural Landmark-based Navigation . . . . .	12
2.3.3	Line Navigation . . . . .	13
2.4	Vision-based Navigation . . . . .	14
2.5	Behavior/Soft Computing-based Navigation . . . . .	15
2.6	Probabilistic-based Navigation . . . . .	16
2.7	Summary . . . . .	16
<b>3</b>	<b>RFID Technology</b>	<b>17</b>
3.1	Introduction . . . . .	17
3.2	Advantages of RFID Systems . . . . .	18
3.3	Components of RFID Systems . . . . .	19
3.4	The RF Subsystem . . . . .	19
3.4.1	RFID Tags . . . . .	20
3.4.2	RFID Readers . . . . .	21
3.4.3	Communication Between Tags and Readers . . . . .	22
3.5	The Enterprise Subsystem . . . . .	23
3.6	The Inter-enterprise Subsystem . . . . .	24

3.7	Summary . . . . .	25
<b>4</b>	<b>Navigation Using Customized RFID Reader</b>	<b>26</b>
4.1	Introduction . . . . .	26
4.2	RFID Reader Architecture . . . . .	27
4.3	Proposed Navigation System . . . . .	28
4.3.1	RFID Communication Module . . . . .	29
4.3.2	Fuzzy Logic Controller . . . . .	30
4.4	Navigation Algorithm . . . . .	35
4.5	Experimental Results . . . . .	37
4.5.1	Testing the Effect of the Robot's Initial Position and Orientation	37
4.5.2	Assessing the Robot's Trajectory Tracking Ability . . . . .	38
4.5.3	Testing a Complex Desired Path . . . . .	38
4.6	Summary . . . . .	43
<b>5</b>	<b>Navigation Using Customized RFID Tag</b>	<b>46</b>
5.1	Introduction . . . . .	46
5.2	Customized RFID Tag Architecture . . . . .	47
5.3	Navigation System Architecture . . . . .	47
5.3.1	RFID Communication Module . . . . .	49
5.3.2	Robot Positioning System . . . . .	49
5.3.3	Fuzzy Logic Controller . . . . .	51
5.4	Navigation Algorithm . . . . .	53
5.5	Simulations and Results . . . . .	55
5.5.1	Following a Two-Segment Path . . . . .	55
5.5.2	Following a Three-Segment Path . . . . .	56
5.5.3	Experiments Using a Conventional Controller . . . . .	60
5.6	Discussion . . . . .	62
<b>6</b>	<b>Conclusion and Future Work</b>	<b>64</b>
6.1	Conclusion . . . . .	64
6.2	Future Work . . . . .	66

# List of Figures

2.1	Categories of research in the field of mobile robot navigation. . . . .	7
3.1	A simple RF subsystem configuration. . . . .	20
3.2	Power supply to an inductively coupled transponder from the reader [11].	23
3.3	A simple enterprise subsystem for robotic application. . . . .	24
4.1	A simplified RFID system with customized reader architecture. . . . .	27
4.2	I, Q projections of a signal $s(t)$ in 2-D space. . . . .	28
4.3	High-level system configuration with two RFID tags. . . . .	29
4.4	$\Delta\phi$ realization in determining the tag location. . . . .	31
4.5	RFID system setup to compute the phase difference. . . . .	32
4.6	Different blocks of a fuzzy logic controller. . . . .	32
4.7	FLC model used by the mobile robot. . . . .	33
4.8	(a) Input and (b) Output membership functions. . . . .	34
4.9	Flowchart of the proposed mobile robot navigation system. . . . .	36
4.10	Experimental setup for testing the effect of initial position and orientation.	39
4.11	Simulation results in reaching a target location. . . . .	40
4.12	Experimental setup for assessing the robot's trajectory tracking ability. .	41
4.13	Simulation results in following a desired rectilinear path. . . . .	42
4.14	Experimental setup for testing a complex desired path. . . . .	44
4.15	Simulation results in following a complex desired path. . . . .	45
5.1	A simplified RFID system with customized tag architecture. . . . .	48
5.2	High-level system configuration with three RFID tags. . . . .	50
5.3	RFID communication module. . . . .	51
5.4	Positioning through trilateration. . . . .	52
5.5	Calculation of angle between the robot and target. . . . .	52
5.6	Fuzzy logic controller used to determine $\Delta\theta$ . . . . .	53

5.7	Flowchart of the proposed mobile robot navigation system. . . . .	54
5.8	Experimental setup of a two-segment path. . . . .	57
5.9	Performance of two-segment trajectory using FLC. . . . .	58
5.10	Experimental setup of a three-segment path. . . . .	59
5.11	RF noise model (a) original vs. noisy signal (b) SNR. . . . .	60
5.12	Performance of three-segment trajectory using FLC. . . . .	61
5.13	Performance of two-segment trajectory using a proportional controller. . . . .	62
5.14	Performance of three-segment trajectory using a proportional controller. . . . .	63

## **Nomenclature**

**AGV:** Automatic Guided Vehicle.

**AIDC:** Automatic Identification and Data Capture.

**CCW:** Counter-Clockwise.

**CW:** Clockwise.

**DGPS:** Differential Global Positioning System.

**EPC:** Electronic Product Code.

**EIRP:** Effective Isotropic Radiated Power.

**FLC:** Fuzzy Logic Controller.

**GPS:** Global Positioning System.

**I:** In-phase.

**Q:** Quadrature.

**RFID:** Radio Frequency IDentification.

**TRP:** Tag Received Power.

# Chapter 1

## Introduction

Manufacturers of outdoor working machines have gradually become interested in autonomous mobile robots. The autonomous robotic vehicles are capable of performing desired tasks in unstructured, uncertain and potentially hostile environments. They can navigate autonomously without human intervention. Current autonomous robots adhere to different levels of autonomy as defined by the existing technology limitations and the sensors used. Important operational characteristics of an autonomous vehicle include *Perception, Intelligence, and Action* [24]:

*Perception: The process of acquiring knowledge about the environment and itself.* This is done by collecting measurements from all sensing devices and extract information that can be used for later tasks such as localization, path planning, collision avoidance, and navigation.

*Intelligence: Activities for a certain amount of time period without any human intervention.* This is associated with the learning and inference capabilities. The autonomous vehicle should be able to adapt itself with the environment.

*Action: Travel from point A to point B.* The robot should utilize the predefined and acquired knowledge to move in dynamic environments without involving humans in the navigation loop.

In robotics, autonomy is mainly associated with navigation issues. From a conceptual point of view, autonomous mobile robot navigation can be achieved via continuous interaction among *perception, intelligence, and action*.

## 1.1 Motivation

Navigation is a central component in any autonomous mobile robotic system. Nowadays, mobile robot navigation has claimed the attention of numerous researchers. In spite of the large body of research works and the significant advances in this field, researchers are yet to reach a comfortable level of satisfaction. Most of the navigation algorithms proposed in the literature to date are either tailored towards particular structured environments or driven by an overwhelming degree of computational complexity [43]. In some cases, the hardware needed to implement the navigation algorithms is even more costly than the robot itself. This makes the practical realization of such algorithms in most real-life robotic systems questionable.

The design and implementation of an efficient navigation algorithm that ensures full autonomy with high precision is a challenging task. This requires designing an efficient sensor network, reliable obstacle avoidance strategy, and a motion planner. Typically, wheeled mobile robots operate in environments that are either partially or completely unknown. Often the environment changes with time in an unknown manner; hence, a navigation system that can enable the robot to autonomously navigate in these working environments is well motivated.

## 1.2 Thesis Objectives and Contributions

The main goal of this research is to investigate the use of RFID technology for the development of a modular, cost-effective and computationally inexpensive autonomous robot navigation system. For that, two different mobile robot navigation algorithms are proposed in this work using customized features of RFID technology. These algorithms are developed under two separate navigation modules. The first method relies on mounting RFID tags on the ceiling of the robot's workspace. The tags are used to define the desired trajectory of the robot. The aim of the navigation algorithm is then to make the robot navigate along the virtual lines linking the orthogonal projection points of the tags on the ground. The tag locations may not need to be known to the robot. This method puts no restrictions on the RFID tags to be used. In fact, any commercially available tag with sufficiently long communication range can be used here. However, a slight modification on the RFID reader architecture from that of commercially available reader had to be made.

In the second navigation module, the number of RFID tags is independent of the path

the robot has to follow. In this case three RFID tags with pre-defined 3-D coordinates are needed to guide the robot through a path of any complexity provided that the RFID tags remains within communication range from the reader which is mounted on the robot. This method is even fault-tolerant in case four or more tags are used. For it to be realized, any commercially available RFID reader with a sufficient communication range can be used. However, the tag architecture has to be redesigned to allow for encoding a few dynamic information within the digital frame that is backscattered to the reader. Unlike other studies of this kind reported in the literature, there is no restriction on where the tags should be mounted. For indoor applications, they can be mounted on the ceiling, whereas in outdoors they can be mounted on posts, for example.

To the best of our knowledge, no navigation techniques to date use RFID technology for the true real-time navigation (not localization) of mobile robots. It is worth to note that the current research is the first milestone of a larger project to provide a fully-fledged practical computationally efficient navigation solution.

It is worth mentioning that several articles have been either published or accepted to be published stem from this research work [14, 15, 33–35, 46–48].

### 1.3 Thesis Outline

The remainder of this thesis is organized as follows. Chapter 2 is devoted to develop a survey on the state-of-the-art in mobile robot localization and navigation techniques for wheeled mobile robots. In Chapter 3, we describe the basics of commercially available RFID systems. Then, we present the two navigation modules for indoor environments using customized RFID systems. The algorithm proposed in the first module presented in Chapter 4 is based on customizing the RFID reader mounted on the robot. The second algorithm is presented in Chapter 5 where the structure of the transponders are modified to extract some navigation parameters. Finally, we highlight some pros and cons of the proposed techniques and how they can be further extended and enhanced in Chapter 6.

# Chapter 2

## Literature Review

### 2.1 Introduction

In this chapter we examine relevant existing mobile robot navigation techniques proposed in the state-of-the-art. It is worth mentioning that the subject of navigation covers large fraction of the research in mobile robotics thus making a comprehensive survey of the available work is outside the scope of this thesis.

The fundamental idea behind the problem of mobile robot navigation can be explored taking into account: localization, goal specification, and navigation. Localization is the problem of determining the own position in a given environment, based on what can be seen and what information was previously acquired. The goal specification and navigation are essentially the problems of identifying a particular goal in an environment and planning a path that results in achieving this goal.

Among the sensors used for mobile robot positioning and navigation are cameras, range finders using sonar, laser and infrared technology, radar, tactile sensors, compasses, and GPS. Initially, researchers focused on laser and sonar-based navigation of mobile robots. Sonars were used as an intelligent sensor. However, since sonars have very low-bandwidth capabilities, they are subject to noise due to wave scattering. Hence, the interest was shifted to laser sensors. Although laser sensors have a much higher bandwidth, they are still subject to noise. Moreover, lasers have a limited field-of-view unless intricate mechanics such as rotating mirrors are incorporated in the sensor design. The rest of the sensors can be utilized in some other navigation techniques which also have several drawbacks in performing accurate navigation in unstructured environment.

The most common and popular navigation techniques suggested in the state of the

art generally fall under one of the following categories: dead-reckoning-based, landmark-based, vision-based, and behavior-based techniques. Each navigation technique has its own advantages and disadvantages, although it is difficult to rate them objectively. Some aspects can be unequivocally compared, such as computational complexity, navigation accuracy, or the amount of information a priori required for the proper operation of the algorithm.

Basically, a dead-reckoning navigation system provides position, heading, linear, and angular velocity of an autonomous mobile robot and it is widely used due to its simplicity and easy maintenance. The odometer is the most simplistic implementation of dead-reckoning which provides a position and an orientation of a mobile robot by using onboard encoder information. The fundamental idea behind this navigation technique is the integration of incremental motion over time [5]. This navigation method is based on continuous encoder readings. The problem of this dead-reckoning navigation system is that small precision errors and sensor drifts inevitably lead to increasing cumulative errors in the robot's position and orientation, unless an independent reference is used periodically to correct the error [39].

Given the shortcomings of dead-reckoning-based navigation, researchers became more interested in the use of landmark-based navigation systems where landmarks are placed at various locations in the environment. These landmarks hold some sort of information which are used by the robot in order to better estimate its position in the environment. However, a landmark-based navigation strategy relies on identification and subsequent recognition of distinct features or objects in the environment that may be a priori known or extracted dynamically. Due to sensors noise and possible dynamic changes of the operating environment, the recognition process of features or objects might become quite challenging. To resolve these issues, some researchers shifted their interest to vision-based navigation systems. Vision sensors can have wide field-of-view, can have millisecond sampling rates, and can be easily used for trajectory planning. However, some disadvantages of vision include lack of depth information, image occlusion, low resolution and the requirement for extensive data interpretation (recognition). Given the advantages and disadvantages of the various sensors, some initial work targeted the use of data fusion to merge various sensors to build a map of the environment for mobile robot navigation [19, 54]. To get rid of extensive image processing in vision-based navigation, some researchers have focused on implementing the navigation algorithm where the emerging RFID technology is employed to localize (not to navigate) the mobile robot in the environment [13]. In the RFID-based mobile robot navigation systems, suggested in the

state of the art to date, RFID tags are attached in the environment and an RFID reader is mounted on the mobile robot. The RFID reader continuously reads the tag IDs from its operating region and sends them to the robot. The robot makes the decision about its position based on the tag IDs collected from the surroundings.

As noted above, the literature refers to the navigation problem in conjunction with the localization problem where the central task is to determine a robot's position. In that case, the problem of estimating where objects lie in the environment and the problem of locating the robot have to be solved in conjunction. Some autonomous robot navigation problems have also been solved using conventional controllers that depend on complex mathematical models [3, 51, 60]. However, the complexity of robot dynamics makes the design of vehicle control systems using conventional approaches difficult. We can categorize the research works in the field of mobile robot navigation as shown in Figure 2.1.

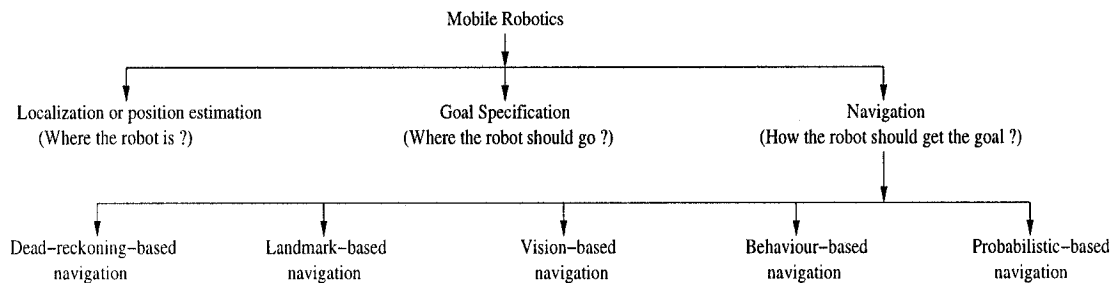

Figure 2.1: Categories of research in the field of mobile robot navigation.

The rest of the chapter is organized as follows. In section 2.2 we present different dead-reckoning-based navigation techniques. A brief overview of landmark-based techniques is presented in section 2.3 which also covers some related works based on an RFID system where RFID tags are utilized as artificial landmarks. Section 2.4 discusses the work on vision systems, and section 2.5 presents some soft computing techniques used in several navigation methods. A brief discussion on probabilistic robotics, which is a new approach for robot localization that was started in the last decade, is presented in section 2.6. Finally, we highlight some important aspects of these navigation techniques in section 2.7.

## 2.2 Dead-reckoning-based Navigation

Dead-reckoning navigation method is a simple mathematical procedure for determining the current location by knowing the previous position through known odometric information and velocity over a given period of time. Most of the dead-reckoning-based mobile robot navigation algorithms use a combination of odometry, and landmark or vision systems. In [30], the authors aimed at studying dead-reckoning and visual landmark recognition as a solution for navigating a vehicle along a predetermined path in forest environment. In this work, a magnetic compass for heading measurement and ground speed Doppler radar for distance measurement were chosen to realize dead-reckoning navigation system. The path in the forest was marked with landmarks which are detected by the camera connected to the computer of the vehicle. The position of the vehicle is determined based on the position of the detected landmarks. The location of the vehicle is also calibrated based on the dead-reckoning information and direction of the landmarks from the vehicle. The fusion of the sensory data from the dead-reckoning system and the landmark direction system is performed through a Kalman filter algorithm. The Authors in [9] described a strategy and control architecture to allow a mobile robot to navigate in indoor environments on a planned path. The navigation system of the mobile robot integrates the position estimation obtained by a vision system with the position estimated by odometry, using a Kalman filter framework. Obstacle detection is performed through several ultrasonic sensors. This system is suitable for a structured or quasi-structured environment and needs a-priori knowledge of the world model. This priori knowledge is designed by means of a CAD system. A CAD description is provided to define an initial setup of the world in order to plan the path in advance.

The indoor autonomous goal-based mobile robot navigation using a cooperative strategy of odometry and a novel visual self-localization method is addressed in [53]. The odometer used in this research is a dead-reckoning sensor which can estimate only relative motion, so to compute the absolute position of the vehicle. The wheels of the vehicle were equipped with an encoder to measure as well as to calibrate the vehicle's relative position and orientation. The visual self-localization method capitalizes on an excellent angular resolution of a CCD TV camera mounted on board. The position and orientation of the vehicle is further calibrated using this standard CCD camera.

A popular dead-reckoning navigation system was developed in [41], where the combination of encoder and gyroscope using an indirect Kalman filter is applied for the reliable position and heading angle estimation in an autonomous mobile robot naviga-

tion system. In this system, the encoder and gyroscope fusion algorithm using indirect Kalman filter algorithm requires the preprocessing of the encoder information. At first a simple encoder based navigation is developed, and then a navigation error model is derived through linear perturbation. The indirect Kalman filter is realized by applying Kalman filter to the navigation error model. Finally, the indirect Kalman filter feeds back the error estimates to the main navigation algorithm. A further extension of this work is proposed in [42] which is based on a differential encoder and a gyroscope, where an AUTOGYRO (Fiber Optical Gyroscope) was used to measure the angular velocity. In this research, the encoder errors are calibrated using a gyroscope. The indirect Kalman filter was adopted for the estimation of encoder systematic errors and gyroscope errors.

The problem of navigation of an autonomous guided vehicle (AGV) was addressed in [2]. The approach proposed in this navigation system is to fuse the odometry and the information provided by a vision system. A point-able camera was utilized to come up with the vision system. The camera is moved in different directions to fix a point in the environment while the AGV is navigating. The coordinates of the landmark are not assumed to be a priori known. The camera is responsible for finding the coordinates of the landmark. The difference of [2] over previous navigation methods is that any point in the observed scene by the camera can be selected as a landmark and not just pre-measured point. In this method, the fusion of odometry and camera measurements is also performed using a Kalman filter.

A more precise navigation system for a 4WS mobile robot is proposed in [18], where the position and orientation estimation is based on GPS and encoders. The estimator consists of two Extended Kalman Filters, Runge-Kutta-based dead-reckoning unit and an Arbitrator, to estimate the position and orientation of the vehicle. An outdoor mobile robot navigation based on DGPS and odometry data fusion was presented in [37] where the position of the robot is fundamentally determined from odometry information. The DGPS measurement data is used to calibrate the estimated position obtained from odometry information. Authors in [32] have proposed a trigonometric method for the calculation of position and orientation based on odometric information. Their platform focused only on the localization problem for autonomous mobile robot navigation. This model was derived to deliver timely and accurate odometric information from measurements of drive wheels' revolutions and steering angles.

As described above, dead-reckoning-based mobile robot navigation can only provide good short-term accuracy, since it accumulates position and orientation errors if navigation is attempted over long distances. Despite these limitations, most of the researchers

agree that odometry is an important part of mobile robot navigation due to its simplicity. Alternatively the inevitable accumulating error associated to dead-reckoning, additional correcting/calibrating methods are necessary.

## 2.3 Landmark-based Navigation

Basically, landmarks are distinct features that a robot can recognize through its sensors. Landmarks can have geometric shapes such as rectangles, lines and circles, and may even include additional information (e.g., in the form of a bar-code). In general, landmarks have fixed and known positions, relative to which a robot can localize itself. Landmarks are carefully chosen to be easily identifiable. For example, there must be sufficient contrast with the background. Before a robot can use landmarks for navigation, the characteristics of the landmark must be known and stored in the robot's memory. The main task in localization is then to recognize the landmarks and to calculate the robot's position with respect to them.

Landmark-based navigation is intended to greatly improve robot position estimation over dead-reckoning by tracking visual features in the environment and using them as landmarks. This measurement returns bearing to the visual feature only. No a priori knowledge regarding the position of the landmarks is assumed. Landmark-based navigation can be classified in the following three categories:

- Artificial landmark-based navigation,
- Natural landmark-based navigation, and
- Line navigation

### 2.3.1 Artificial Landmark-based Navigation

Artificial landmarks are specially designed objects or markers that need to be placed in the environment with the sole purpose of enabling robot navigation. In recent years, a significant research has been conducted on robotics that incorporate several sensors and landmarks (artificial and natural) as navigation media in an operating environment.

Hallmann and Siemiatkowska [16] used a mobile robot B14 to navigate in a partially known environment. The vehicle is equipped with 16 sonars, 16 infrared sensors, on-board Pentium computer system, and one gray-scale camera. The map of the robot's

environment is represented as grids of cells. Circular shaped landmarks, two vertical parallel strips and H-shaped landmarks are considered as the artificial landmarks which help the robot's self-localization in the environment while navigating. The images of these artificial landmarks are taken using a gray-scale camera and then some image processing techniques are applied for the recognition of the landmarks in the environment for accurate positioning. The path of the mobile robot is determined using a diffusion method. The indoor mobile robot navigation presented in [62] uses a global ultrasonic system for locating the robot. The global ultrasonic system consists of four ultrasonic generators fixed at a priori known positions in the workspace and two receivers mounted on the mobile robot. An extended Kalman filter is opted to process the sensory data to locate the robot.

Recently several researchers have developed what is now a highly successful family of approaches capable of solving the localization problem efficiently: navigation algorithms based on RFID technology where the reader of the RFID system is mounted on the robot while the transponders are attached at different locations as artificial landmarks. Khubitiz et al. presented a navigation system that uses RFID tags as artificial landmarks [26]. The tags' global position, environment class, environment position, and further optional data are pre-stored in the tags' memory. The system also employs a behavior-based control architecture which enables the robot to reach any landmark within its working environment through a topological robot positioning approach. The behavior-based control architecture is specially designed to be able to integrate several positioning sensors with different accuracies and error categories while enabling the robot to navigate. A new navigation system in man-made environments, such as hallways, was developed in [58], where RFID tags are used as artificial landmarks and the mobile robot is equipped with an on-board laptop computer, an RFID tag sensor and a vision system. The RFID reader is mounted on the robot itself while the tags are pasted at particular locations on walls. At the junction of two passages, the RFID tag sensor reads the unique tag identification numbers and infers the necessary actions (turn left, right, or remain straight) to reach the desired positions. In [29], the authors developed an indoor location sensing prototype which can be used for various mobile commercial applications. This suggested prototype uses RFID technology for locating objects inside buildings. In 2005, another technique was proposed by Tsukiyama [59], where the robot tries to build a topological map of its surrounding environment to be used in path planning and navigation. Each node in the topological map is the intersection point of two passages. At these points, the robot has to decide on the next action according to a plan stored in the robot's memory

to reach the target position. The robot then follows certain paths using an ultrasonic range finder until a tag is found. However, such a methodology is specific to a particular workspace and requires a substantial amount of customization for it to operate in a new environment. Chae et al. proposed a mobile robot localization method with the help of a combination of RFID and vision [20]. The global localization of the robot is performed by incorporating signal detection from artificial landmarks represented by RFID tags. The tags are assigned different weights which are determined by the RFID reader mounted on the robot. The algorithm takes advantage of a vision system incorporating a feature descriptor derived from a scene view of the robot environment, which provides the fine position and orientation of the robot. Although this algorithm offers an efficient localization method, it naturally inherits the typical shortcomings of vision-based techniques in general.

### 2.3.2 Natural Landmark-based Navigation

In addition to artificial landmarks, natural landmarks have also been exploited in a number of robot navigation algorithms. Borenstein et al. in [22] defined natural landmarks as those objects or features that are already in the environment and have a function other than robot navigation. There are so many examples of natural landmarks: trees, lampposts, furniture, lamps and so on. These landmarks will be chosen depending on the environment (e.g. indoor or outdoor). The main challenge then becomes to extract those landmarks from the entire scene in a robust way in order to generate a spatial representation. In the context of natural landmark-based mobile robot navigation, the representation of the landmarks in the environment is a crucial point. Geometric modeling can be used to deal with two fundamental tasks: landmark extraction and recognition for sensor-based motion control or robot localization. However, geometrical representations can lead to a bulky model and after some iteration, to a combinatorial explosion.

For instance, Betge-Brezetz et al. [4] focused on the high level representation of the natural scene to guide a mobile robot in a priori unknown environment. The landmarks in this case are defined as natural objects extracted from perceptual data. The scene is structured into elements corresponding to its main entities and only the parametric description is employed to characterize the shape of every entity. A segmentation algorithm has been adopted to distinguish different components in the 3-dimensional scene. After that, the object models are built using a quadratic representation. Finally, the objects and the topological models are merged to construct the scene model which is ultimately

used for the navigation control. Wijk and Christensen developed a similar algorithm for natural landmark extraction from sonar data streamed from a mobile platform [61]. In this work, the robot's absolute position is determined through a matching procedure between the recently collected landmarks and the reference map. The natural point landmark extraction method adopted consists of a double-fold filtering process of sonar data: a triangulation-based fusion and a completion of the landmark hypothesis. In the first layer, two-dimensional data points are filtered out and the best triangulation points from the first filtering stage are considered in the second layer. Then, in the second layer, these extracted landmark points are used to match the reference map in order to localize the robot in its working environment.

### 2.3.3 Line Navigation

Line navigation is another type of landmark-based navigation that has been widely used in industry. Some researchers proposed mobile robot navigation methods using lines marked on the floor [10,31]. A continuous, straight-edged line is employed for the visual navigation of an autonomous mobile robot. An intelligent line-tracking navigation and a policy control method assist a mobile robot rolling along an indicated line on the ground, to ensure it automatically navigates home after leaving the line and finishing its tasks. Line navigation can be thought of as a continuous landmark, although in most cases the sensor used in this system needs to be very close to the line, so that the range of the vehicle is limited to the immediate vicinity of the line. These techniques have been used for many years in industrial automation tasks and vehicles. However, the techniques are not discussed in detail here since they do not allow the vehicle to move freely - the main feature that sets mobile robots apart from AGVs.

The recognition process of features or objects in landmark-based navigation system might be too complex in dynamically varying environments. A simple solution to this issue is addressed in [21] where the mobile robot is utilized to operate in manufacturing industry. In this research, the navigation algorithm is capable of locating the robot and updating the landmarks in a dynamic manufacturing environment. The Extended Kalman Filter algorithm is adopted in the navigation system to improve the localization accuracy of the mobile robot. Both artificial and natural landmarks are deployed in order to provide useful solution toward real-world applications. The position of the mobile robot is initialized autonomously and recalibrated using a Kohonen neural network. This navigation algorithm can be applied in a mobile robot to be applicable at home, office

and hospitals where many features are available.

## 2.4 Vision-based Navigation

Vision plays a crucial role in autonomous robot navigation. Ultimately, interaction with unknown, complex, dynamic environment requires some visual sensory data processing techniques. Significant research in the literature based on vision sensors mounted on mobile robots have been conducted.

Kotani et al. [25] described a navigation system for an autonomous mobile robot in outdoor environments which uses vision to detect landmarks and DGPS information to determine the robot's initial position and orientation. The vision system is responsible for detecting landmarks in the environment by referring to an environmental model. As the robot moves, it estimates its position by conventional dead-reckoning, and matches up the landmarks with the environmental model in order to reduce the error in the robot's position estimation. Navigation using single-camera vision and ultrasonic sensors has been studied in [38] where self-localization of the robot is done using a model-based vision system, and nonstop navigation is realized by a retroactive position correction system. For self-localization, the robot first renders an expectation image using its current best estimate of its present location and then the model edges extracted from the expectation image are compared and matched with the edges extracted from the camera image through an extended Kalman filter. The Kalman filter automatically then yields updated values for the location and the orientation of the robot.

Authors in [1] have developed a vision-based navigation system where global matching is defined as the behavior that is able to relocate the position of the robot which is calculated by locating the corners in the workspace. Murray and Little [36] focused on building occupancy grid maps of the environment and presented a method for reducing stereo vision disparity images to two-dimensional map information. The robot can navigate and autonomously explore the environment using this information. However, building a map of the environment is a complex task. To alleviate this complexity, a novel qualitative vision-based navigation algorithm is proposed in [6] where the algorithm is entirely qualitative in nature, requiring no map of the environment, image Jacobian, homography, fundamental matrix, nor assumption about a flat ground plane. In this teach-reply approach, the robot is manually led along a desired path in a teaching phase, then it automatically follows that path in a reply phase. This method requires a single off-the-shelf, forward-looking camera with no calibration. Several vision-based naviga-

tion systems have been recommended in [8] to improve the robot position estimation by tracing visual features in the environment and using them as landmarks. These measurements usually returns bearing to the visual features only, with no a priori knowledge of the landmark positions.

Despite the aforementioned contributions, vision-based navigation techniques still suffer from several disadvantages, including the lack of information depth, complex image processing algorithms with high computational complexity, and its dependence on the working environment. Furthermore, such methods are very sensitive to the lighting conditions of the robot workspace.

## 2.5 Behavior/Soft Computing-based Navigation

As the development of different autonomous robot navigation techniques in real-world environments constitutes one of the major trends in current research on robotics, one important problem is the need to cope with the large amount of uncertainty inherited from natural environments. As such, soft computing techniques have received a considerable attention in recent years. Numerous navigation techniques have been suggested in the state of the art using some tools of computational intelligence such as fuzzy logic, neural network, neuro-fuzzy system, genetic algorithm, and several combinations of them.

The natural appeal of fuzzy logic to robot navigation has motivated several researchers in this area [28, 50]. In 2005, Parhi proposed a new direction of work where fuzzy logic and Petri Net models were employed for the navigation control of multiple mobile robots in a cluttered environment [40, 44]. The fuzzy logic system embedded in the controller of the robot is responsible for avoiding static obstacles other than robots. The input of the fuzzy logic system was sensory data whereas the output was the steering angle that needs to be applied on its wheels to direct itself in the proper direction. The function of the Petri Net model is to avoid collision among robots operating in the environment. Although, fuzzy logic proved to be effective in coping with uncertain environments, it has some limitations. In a purely fuzzy system, the parameters cannot be optimized in an analytical way. Therefore, they cannot be applied for learning and tuning fuzzy rules. On the other hand, neural networks can easily map empirical training set through learning. As a result, they have been successfully applied in several research bodies in robotics [27, 45]. Nevertheless, the mapping rules in the network are not visible and are difficult to understand. A better performance can then be achieved by combining both fuzzy logic and neural network systems in a neuro-fuzzy system [49].

## 2.6 Probabilistic-based Navigation

In most robotic applications, the robots have to be able to accommodate the enormous uncertainty that exists in the physical world [57]. Probability theory is a relatively new approach to robotics and plays tribute to the uncertainty in robot perception and action. The key idea in probabilistic robotics is to represent uncertainty explicitly using probability theory. This approach became quite popular in the last decade.

In [55], Thrun suggested a localization algorithm for a mobile robot based on Markov Localization which has recently been employed in several recent robotic systems. The mobile robot learns a set of landmarks for localization using Bayesian learning, and artificial neural networks are used to recognize those landmarks during its navigation in the environment. A concurrent mapping and localization for robots is studied in [56]. The computational complexity degrades the performance of these algorithms in highly unstructured environments. To overcome this issue, a Monte Carlo localization method was proposed in [7, 12] for a more efficient position estimation. A major difference of this localization approach over previous techniques is that the robot uses randomized samples to represent its position.

## 2.7 Summary

In this chapter we presented relevant background of our work. Several advantages and disadvantages of each mobile robot navigation technique described above are also illustrated. Dead-reckoning navigation techniques are simple but accumulate error over time during the navigation of a mobile robot in its working environment. Landmarks and vision systems are appropriate for robot localization. However, they require precise image processing techniques and are too dependent on environment's lighting conditions. Behavior-based and probabilistic-based techniques suffer from high computational complexity while navigating the mobile robot in unstructured environments.

# Chapter 3

## RFID Technology

### 3.1 Introduction

In recent years automatic IDentification (Auto-ID) procedures have become very popular in many service industries, purchasing and distribution logistics, industry, manufacturing companies and material flow systems. RFID is simply a technology that involves tags which emit signals to other devices called readers (or interrogators) which then pick up those signals.

Normally, a commercially available RFID system is composed of three main parts: a reader, tag, and a host computer. The tag is composed of an antenna coil and a silicon chip that includes a basic modulation circuitry and a non-volatile memory. It is energized by a time-varying electromagnetic radio frequency (RF) signal that is transmitted by the reader. When the RF field passes through an antenna coil, there is an AC voltage generated across the coil. This voltage is rectified to result in DC voltage for the device operation. The device becomes functional when the DC voltage reaches a certain level. The information stored in the device is then backscattered to the reader. A reader is mainly composed of an RF transceiver and a decoding sections. In addition, the reader also includes a RS-232 or USB interface in order to perform serial communication with a host computer attached to it. The RF transceiver section is responsible for transmitting and receiving the RF signal. Data decoding for the received signal is accomplished through a microcontroller. A firmware algorithm is written in such a way to transmit the RF signal, decode the incoming data, and communicate with the host computer.

Because of the simplicity, the RFID system has been used for many years in various remote sensing applications, specifically in access control and animal tracking applica-

tions. Nowadays, RFID chips, in order to track animals, are extremely small devices injected via syringe under skin. RFID systems are being used in some hospitals to track a patient's location, and to provide real-time tracking of the location of doctors and nurses in the hospital. In retail stores, RFID offers a real-time inventory tracking and allows companies to monitor and control inventory supply at all the time.

This chapter provides a brief introduction to RFID technology. It begins with presenting the benefits of RFID technology relative to other automatic identification and data capture (AIDC) technologies in section 3.2. Section 3.3 reviews the basic components of RFID systems and provides background information needed to understand the literature in the next two chapters.

## 3.2 Advantages of RFID Systems

RFID represents a technological advancement in AIDC because it offers advantages that are not available in other AIDC systems such as bar code reading. RFID offers these advantages because it relies on radio frequencies to transmit information rather than light, which is required in AIDC systems. The use of radio frequencies means that RFID can communicate:

- without line of sight, because radio waves can penetrate many materials,
- at greater speed, because many tags can be read quickly, whereas optical technology, for example, often requires time to manually reposition objects so as to make bar codes readable,
- over greater distances, since many radio technologies can transmit and receive signals more effectively than optical technology under most operating conditions.

The ability of the RFID technology to communicate without optical line of sight and over greater distances than other AIDC technology further reduces the need for human involvement in the identification process. The RFID technology often supports other features that bar codes or AIDC technology do not have, such as rewritable memory, security features, and environmental sensors that enable the RFID system to record history of events.

### 3.3 Components of RFID Systems

RFID systems can be very complex, and their implementations vary greatly across industries and sectors. For discussion purposes in this thesis, we will primarily divide an RFID system into three subsystems:

- An RF subsystem, which performs identification and related transactions through wireless communication,
- An enterprise subsystem, which contains computers (or processing elements) running specialized software that can store, process, and analyze data acquired from RF subsystem transactions to make the data useful to a supported business process, and
- An inter-enterprise subsystem, which connects enterprise subsystems when information needs to be shared across organizational boundaries.

The following is a description of each of these subsystems. In this thesis, we are mainly interested in RF subsystem.

### 3.4 The RF Subsystem

There are two major components of an RF subsystem:

- RFID tags (also referred to as transponders), which are small electronic devices that can be attached to or incorporated into a product, animal, person, or 3-dimensional places, for the purpose of identification using radio waves. The RFID tag can automatically be read from several meters away and does not have to be in the line of sight of the reader. Each tag has a unique ID number known as the identifier and may also have other features such as memory to store additional data, environmental sensors, and security mechanisms.
- RFID readers, which are devices used to interrogate RFID tags and read radio frequency waves emitted by the tags. These devices are responsible for communicating with the tags wirelessly to identify the item connected with each tag.

Figure 3.1 depicts a simple configuration of an RF subsystem which is basically composed of three simple blocks, a reader, a tag, and a wireless channel [11]. Both the reader and the tag are two-way radios. Each block is equipped with an antenna and is capable of modulating and demodulating RF signals.

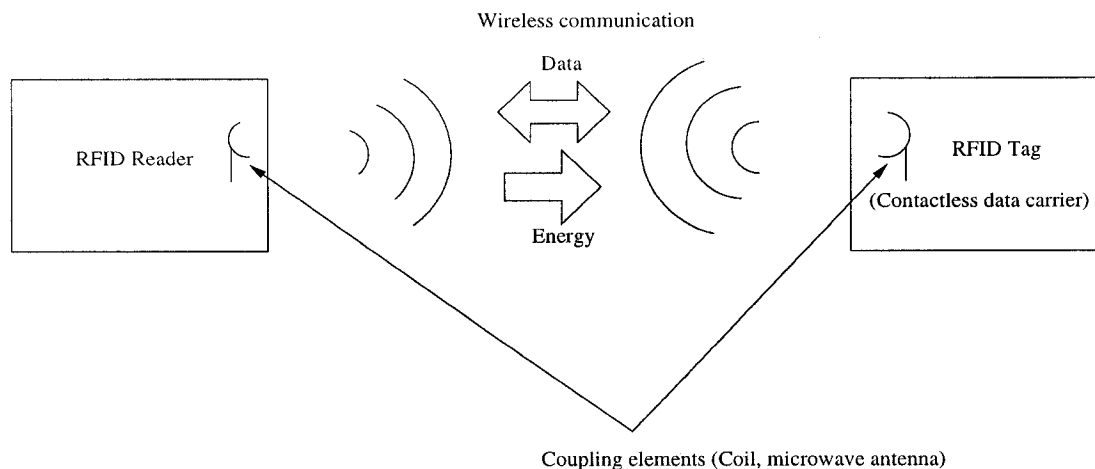

Figure 3.1: A simple RF subsystem configuration.

### 3.4.1 RFID Tags

Numerous types of tags are available in the market. They differ greatly in their cost, size, performance, and security mechanisms. Even when tags are designed to comply with particular standards, they are often further customized to meet the requirements of specific applications. The major characteristics of a tag include: identifier format, power source, operating frequencies, functionality, and form factor. A tag identifier is used to identify the tag itself. There are many data formats available for encoding identifiers on tags. System designers often prefer using identifiers that have a standard structure with certain groups of bits representing particular fields. A tag identifier format that is used across many industrial sectors is the Electronic Product Code (EPC). Normally, a standard tag identifier format consists of four fields: a header (which specifies the EPC type), an EPC manager ID (which uniquely identifies the organization), an object class (which identifies a model of several objects), and a serial number (which uniquely describes the instance of that model of objects).

Tags need power to perform functions such as sending radio signals to a reader, storing and retrieving data, and performing other computations. Tags can obtain this power from a battery or from electromagnetic waves emitted by readers that induce electric current in the tags. The power requirements of a tag depend on several factors including the operating distance between the reader and the tag, the radio frequency being used, and the functionality of the tag. In general, the more complex functions

the tag supports, the greater its power requirements. The two main categories of RFID tags which are based on the power source for communication and other functionality are *active* tags, and *passive* tags.

The frequency at which the tag transmits and receives signals is termed as the operating frequency. In general, as the tag's operating frequency increases, its signals are able to carry more data. As a result, higher frequency readers are also able to read more tags in a given period of time. In addition, an RFID system that operates at an ultra high frequency or microwave frequency is designed to have a longer operating range than low or high frequency range systems.

The primary function of a tag is to provide its identifier to a reader, but many types of tags support additional capabilities, such as memory, integration of environmental sensors, security, privacy protection, and so on, which can be valuable for certain business purposes or specific applications.

The form factor of a tag refers to its shape, size, packaging, and handling features. To a large extent, a tag's form factor is determined by the characteristics previously discussed, such as power source and functionality. Some important aspects regarding a tag's form factor include the size of the tag, the weight of the tag, and the method by which the tag is affixed to and removed from its associated object. Tags also vary in size from smaller than a postage stamp to about the size of a common document stapler.

### 3.4.2 RFID Readers

An RFID reader is a device used to interrogate tags. As such, the tag and the reader must comply with the same standards in order to communicate. The characteristics of a reader that are independent of the tag characteristics include: power output and duty cycle, enterprise subsystem interface, mobility, and antenna design and placement. In the following, we provide a short description of these characteristics.

In most cases, standards and regulations determine the power output and duty cycle of the reader. A reader's duty cycle is the percentage of time that the device is emitting energy over a specified amount of time. Readers that communicate with passive tags need greater power output than those that communicate with active tags because the signals must be strong enough to reach the tag and enable the backscatter to return back to the reader. In general, readers with greater power output and duty cycle can read tags quicker more accurately, and within longer distances, but a greater power output also increases the risk of eavesdropping.

In most of the readers, there are two main interfaces, one is the RF interface used to communicate with the tags, and the other is the enterprise subsystem interface which is used to communicate with enterprise subsystems. The enterprise subsystem interface supports the transfer of RFID data from the reader to the enterprise subsystem's computers (or other processing elements) for further processing of data. Usually, the enterprise subsystem interface is employed for a remote management of the RFID reader. This interface may be wired (e.g. Ethernet) or wireless (e.g. Wi-Fi) depending on the application.

As mentioned above, a reader's interface with an enterprise subsystem may be either wired or wireless. Most wired readers are in fixed locations and support applications in which the tags approach the reader. Some wired readers offer limited mobility using cables. In some cases, the readers are attached to a particular device and the device itself can move around to perform specific tasks. In contrast, wireless readers support applications in which personnel must move around to read tags. A mobile reader usually uses different communication protocols on its RF and enterprise subsystem interfaces, even though both interfaces are wireless.

Readers use a wide variety of antenna types. Each type has a different coverage pattern. To reduce the likelihood of eavesdropping and minimize the interference with other radios, the coverage should only encompass a range that is just sufficient to communicate with the intended tags. Antennas may be integrated into the device or can be detachable. Readers that support detachable antennas are better suited for applications that require specific coverage areas since an antenna can be easily selected or customized to meet those requirements.

### 3.4.3 Communication Between Tags and Readers

RFID does not require a line-of-sight communication. Radio frequencies are used to communicate between the tag and the reader. The reader performs several functions, one of which is to produce a low-level RF magnetic field. The RF magnetic field (see Figure 3.2) emanates from the reader by means of a transmitting antenna, typically in the form of a coil. The magnetic field serves as a "carrier" of power from the reader to the RFID card or tag.

The RFID tag contains an antenna, also in the form of a coil and an integrated circuit (IC). The IC requires a small amount of electrical power in order to function. The antenna in the tag provides a means for gathering the energy present in the magnetic

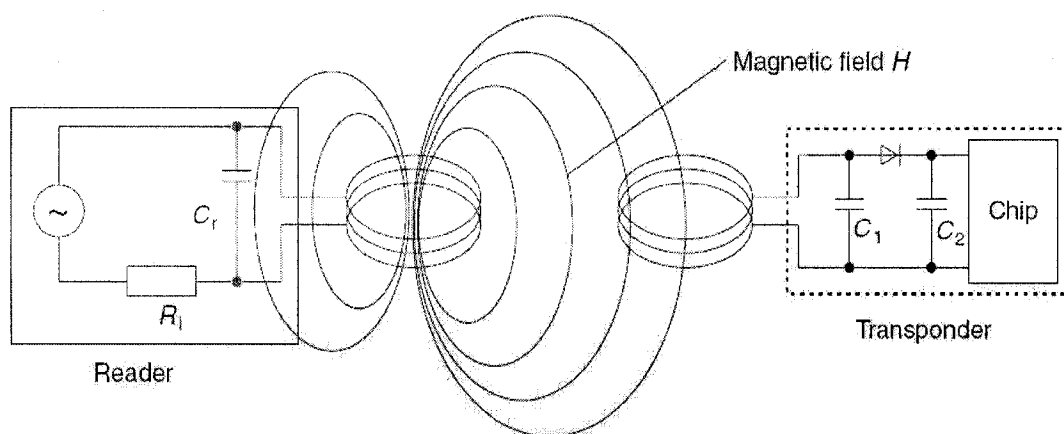

Figure 3.2: Power supply to an inductively coupled transponder from the reader [11].

field produced by the reader and converts it to an electrical form of energy to be used by the IC.

When a tag is brought into the magnetic field produced by the reader, the converted energy powers the IC. This enables the transmission of the IC's memory contents in the form of an electromagnetic signal to the reader via the tag's antenna. The tag information is received by an antenna within the reader and converted back into an electrical form. The reader contains a sensitive receiving system that is designed to detect and process the tag signal. Once the tag data has been processed, a microcomputer within the reader checks to verify that the signal received is valid. Once the reader has checked and validated the received data, the data is then decoded and restructured for transmission to the end-user's host computer. This restructuring provides the data in both an electrical form and a protocol (or format) that is required by the host computer system. Once the restructuring process is complete, the data is transmitted to the host system.

### 3.5 The Enterprise Subsystem

The purpose of the enterprise subsystem is to interact readers to computers or other processing elements running software that can store, process, and analyze data acquired from the RF subsystem. In the current research work we are interfacing the readers with the processing elements mounted on the robot. A simple high level architecture of the enterprise subsystem employed for our current research is depicted in Figure 3.3

where it consists of three major components: middleware, an analytic system and a network infrastructure. The information (at the reader) collected from the tags are passed to the processing elements of the robot using middleware. The middleware is responsible for preparing data collected from the readers for the analytic system. It also hides the complexity and implementation details of the RF subsystem from the analytic system. The analytic system is composed of a database, data processing applications, which process data output from the middleware based on the application requirements. The communication between the RF and enterprise subsystem can be accomplished via several network infrastructures.

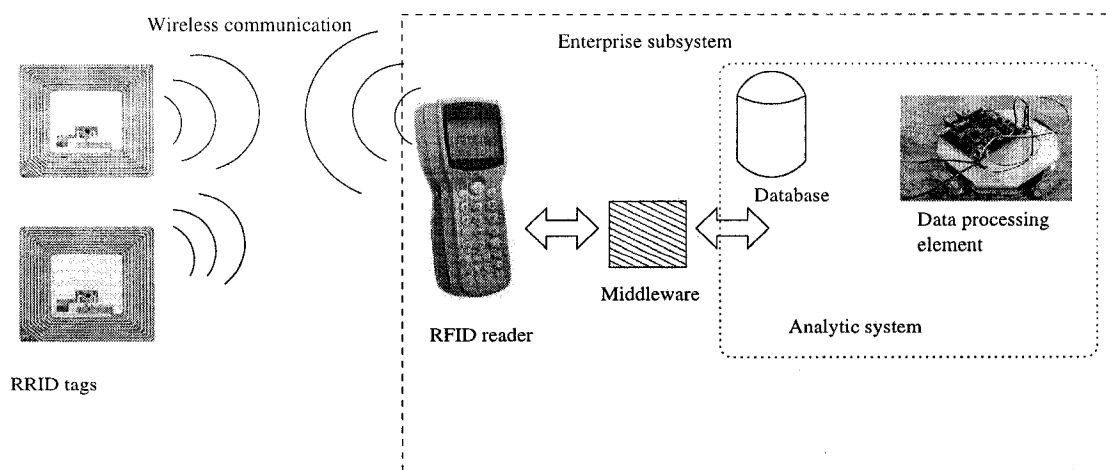

Figure 3.3: A simple enterprise subsystem for robotic application.

### 3.6 The Inter-enterprise Subsystem

The inter-enterprise subsystem connects enterprise system together with large organizational boundaries. In some cases, the information from enterprise system needs to be shared across a large geographical area. Normally, both enterprise and inter-enterprise subsystems involve most commonly available IT components, such as servers, databases, and networks in order to comply with a large body of communications.

### 3.7 Summary

In this chapter we presented some background information of RFID technology while illustrating its various advantages relative to other similar technologies. A basic configuration of an RFID system consists of two essential components: the transponder and the reader, both of which function as two-way radios. The transponder, which is identified by a unique ID, receives energy from the reader in order to power up its IC memory. It then backscatters the ID to the reader. The power output of the reader is an important factor to be considered while communicating with the transponder within longer distances. The next two chapters will illustrate how to customize these two components of an RFID system. We then proceed to employ several features of those components in designing two mobile robot navigation algorithms.

# Chapter 4

## Navigation Using Customized RFID Reader

### 4.1 Introduction

This dissertation consists of two separate navigation modules. In this chapter we explore the design and implementation of the first module for the navigation of a mobile robot in an indoor environment. Here, a customized RFID reader is used to achieve this goal. The navigation algorithm proposed in this chapter uses a customized reader mounted on the mobile robot and a number of tags attached in three dimensional workspace. The reader continuously sends RF signals to the tags in its operating region and receives some analogue information represented in the “phase difference” of the received signal. This phase difference is then passed to the fuzzy logic controller of the robot to take necessary control actions for the actuators of the robot. The reason why fuzzy logic controller is employed is to overcome unnecessary oscillations in the robot path while it navigates in the environment.

The remainder of this chapter is organized as follows. In the next section we discuss how the RFID reader is customized in order to achieve the navigation system of the first module. Section 4.3 introduces the overall architecture of the algorithm that involves two major parts: the RFID communication module and the fuzzy logic controller. Then, we detail the key steps of the suggested algorithm in section 4.4. Finally, the experimental results are summarized in section 4.5, before we conclude the chapter in section 4.6 with a summary of the findings reached thus far.

## 4.2 RFID Reader Architecture

In this section we detail how an existing RFID reader architecture can be customized in order to better suit navigation algorithms of mobile robots. In some cases, some parts of an RFID system can be customized based on specific applications. A simplified RFID system with customized reader architecture which can be applied in an application like mobile robot navigation is depicted in Figure 4.1. In this system, a communication antenna is usually built within the tag, whereas the reader is equipped with two receiving antennas and one transmitting antenna. The RFID sensing method used in the current navigation module relies on processing the backscattered signals within a specific frequency range. The wave broadcasted by the reader is in the form of single-tone sinusoidal signals with different frequencies using time multiplexing. We are particularly interested in the phase,  $\phi$ , of the baseband signal received at the reader's end as a result of the tag's response. In order to illustrate  $\phi$ , consider a two dimensional signal space  $(x(t), y(t))$  of a signal  $s(t)$ , as shown in Figure 4.2. The quantities I and Q are the In-phase and Quadrature projections, respectively, of the signal  $s(t)$ . The phase  $\phi$  is thus defined as in (4.1).

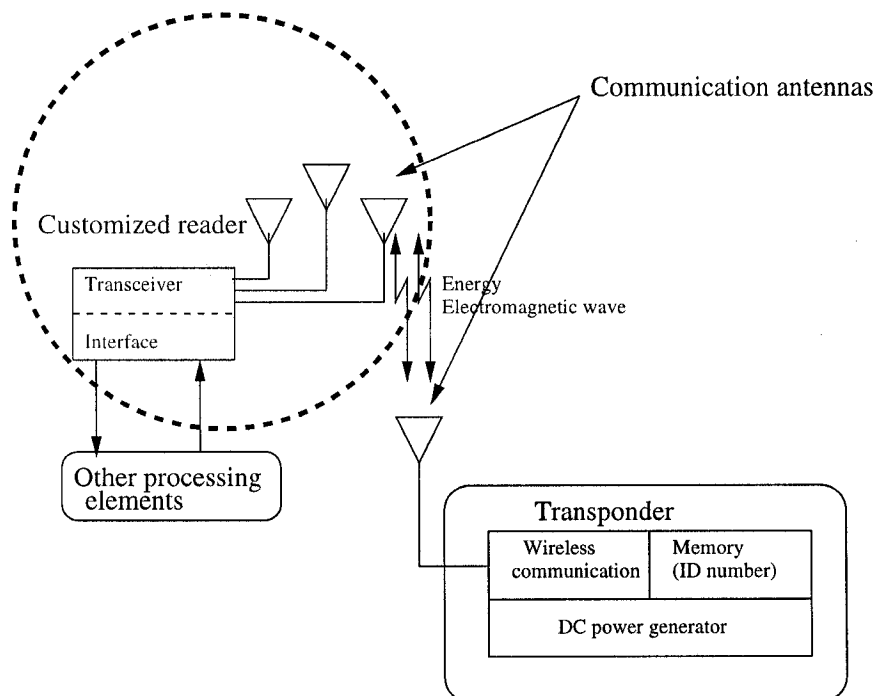

Figure 4.1: A simplified RFID system with customized reader architecture.

$$\phi = \tan^{-1} \left( \frac{I}{Q} \right) \quad (4.1)$$

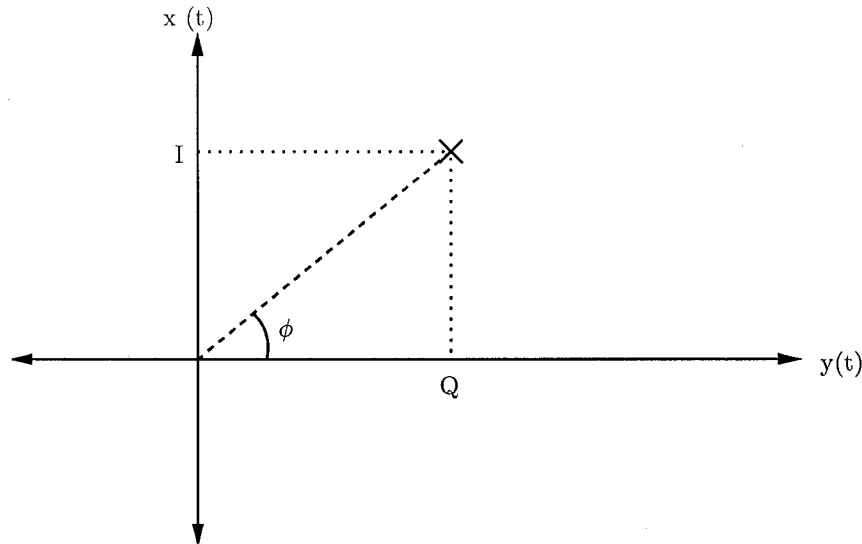

Figure 4.2: I, Q projections of a signal  $s(t)$  in 2-D space.

### 4.3 Proposed Navigation System

The general high level architecture of the navigation system suggested in this chapter consists of an RFID communication module and a fuzzy logic controller, in addition to the software performing data processing and computing the necessary control actions. The proposed technique relies on RFID tags placed in the 3-dimensional space so that the lines linking their projection points on the ground virtually define the “free ways” along which the robot can (or is desired to) move. It should be articulated here that the locations of the tags are completely unknown to the robot. The robot is pre-programmed with an ordered list of tag ID numbers defining its desired path. For instance, if the robot is given the list of tag IDs (4, 9, 1, 5), then it is supposed to navigate to the closest point it can reach to tag number 4, then move in a straight line to the closest point it can reach to tag number 9, and from there to tag number 1 and then to tag number 5. The closest point to a tag that the robot can reach is usually the orthogonal projection point of that tag on the ground. During navigation, the robot continuously reads the ID’s of all the tags within reach but will only further process the signal coming from the destination tag

at that time instant. The communication with the tags is performed through an RFID reader with two receiving antennas mounted on the robot. A high-level configuration setup of the current system with two RFID tags,  $T_1$  and  $T_2$ , is depicted in Figure 4.3. In this configuration, the robot's desired path is the straight line segment between the tags' orthogonal projection points on the ground, A and B. In the following, we provide a detailed description of how this is achieved through a customized RFID communication module and fuzzy logic controller.

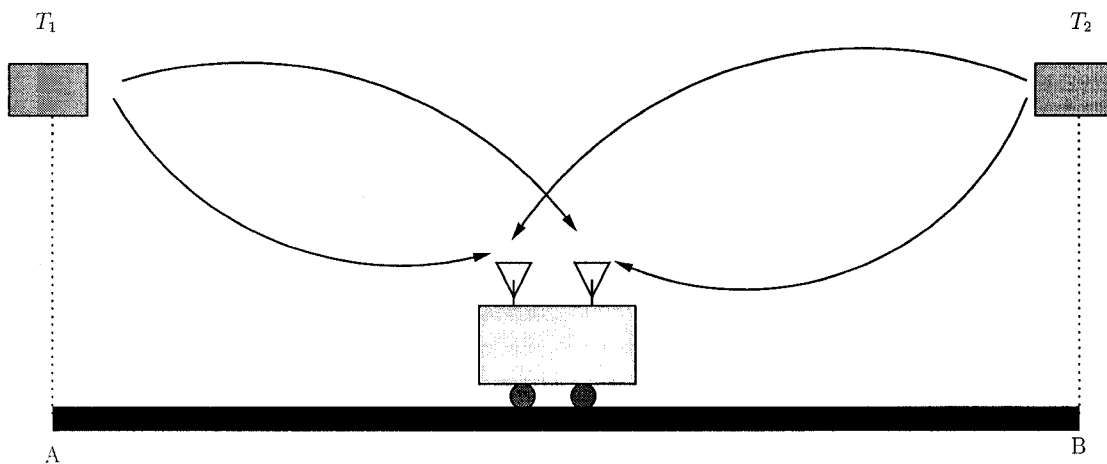

Figure 4.3: High-level system configuration with two RFID tags.

### 4.3.1 RFID Communication Module

During the robot's navigation, the RFID reader sends time-multiplexed single-tone sinusoidal signals with different frequencies, and then listens to the backscattered signals from the RFID tags. Particularly, we are interested in the signal broadcasted by the tag representing the robot's destination at that time instant. Let  $\phi_1$  and  $\phi_2$  be the phase angles of the signal received by the reader's reception antennas 1 and 2, respectively (as defined by (4.1)). This information is then used to calculate the signal's phase difference as it will later be used by the fuzzy logic controller to decide on the necessary control action to time the robot's direction. The phase difference  $\Delta\phi$  is computed as in (4.2).

$$\Delta\phi = \phi_1 - \phi_2 \quad (4.2)$$

None of the commercially available RFID readers to date is capable of providing the signal's phase defined in (4.1). This is simply because all what these readers currently

offer is the ID number of the transponders within its communication range. As a result, preliminary studies were conducted using a custom-made RFID reader and a digital oscilloscope to confirm the fact that the phase difference defined in (4.2) can indeed be used to know if the tag lies on the left or the right of the vertical plane perpendicular to the ground. Figure 4.4 illustrates this idea by placing the RFID tag at the left side of the mobile robot. The midpoint of the line segment connecting the two receiving antennas mounted on the reader ensures the tag location on the ground to be at the left side. In this case the phase angle of the left antenna is less than that of the right antenna of the reader which results in a negative phase difference. As a consequence, the robot has to turn left in order to reach the destination tag. This technique can be easily implemented in the future using any commercial reader capable of providing either the signal's phase directly, or some sort of other relevant data through which it can be computed.

The real custom-made RFID system consists of a signal generator that generates continuous wave signals with an embedded BPSK-modulated PN sequence [52]. The two directional antennas on the reader are then used to receive the backscattered signal. The In-phase ( $I$ ) and Quadrature ( $Q$ ) components of the received baseband signal are sampled and stored using the digital oscilloscope. This information is then fed to the high-level navigation algorithm to compute the phase difference as defined in (4.2). A high-level architecture of this custom-made RFID setup is given in Figure 4.5. The data collected in this experiment offline is used later to model the RFID module in the computer simulations.

### 4.3.2 Fuzzy Logic Controller

Fuzzy logic control has become an important methodology in control engineering because of its appropriateness in various complex or ill-defined systems. Instead of representing the system as a set of complex mathematical equations, fuzzy controllers use a set of well-structured if-then rules to represent the input-output relationships of the system. The suitability of FLCs does not depend much on the number of input and outputs, but rather depends on the availability of the decisions inferred through human-like linguistic descriptions [23]. This information would then be factored into deriving the behavioral response of the mobile robot. The present algorithm uses the phase difference that can be easily modeled through a human-like reasoning mechanism.

All FLCs have three major functional components: fuzzification, inference system, and defuzzification [23]. In the block diagram of Figure 4.6, the fuzzy controller lies

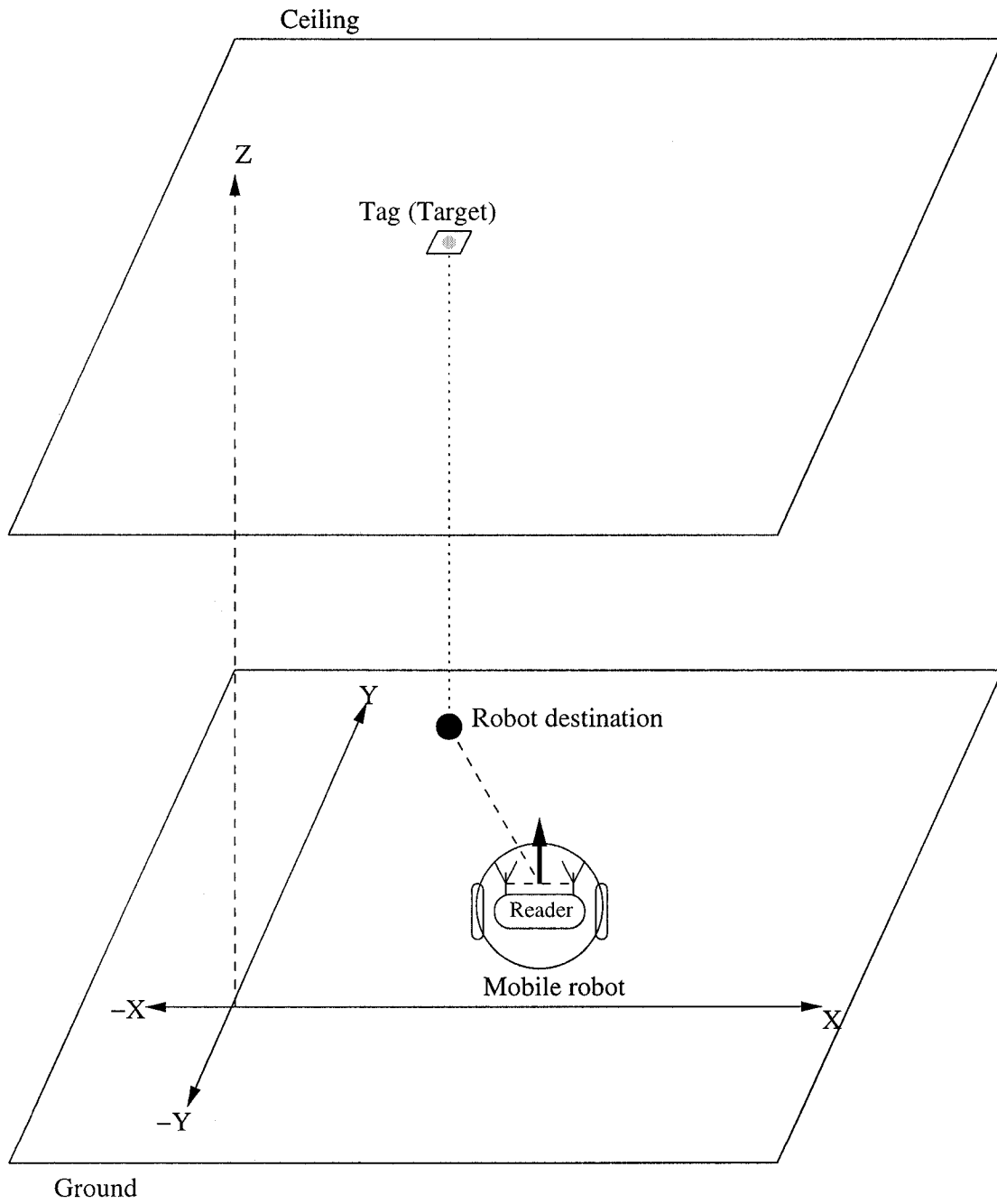

Figure 4.4:  $\Delta\phi$  realization in determining the tag location.

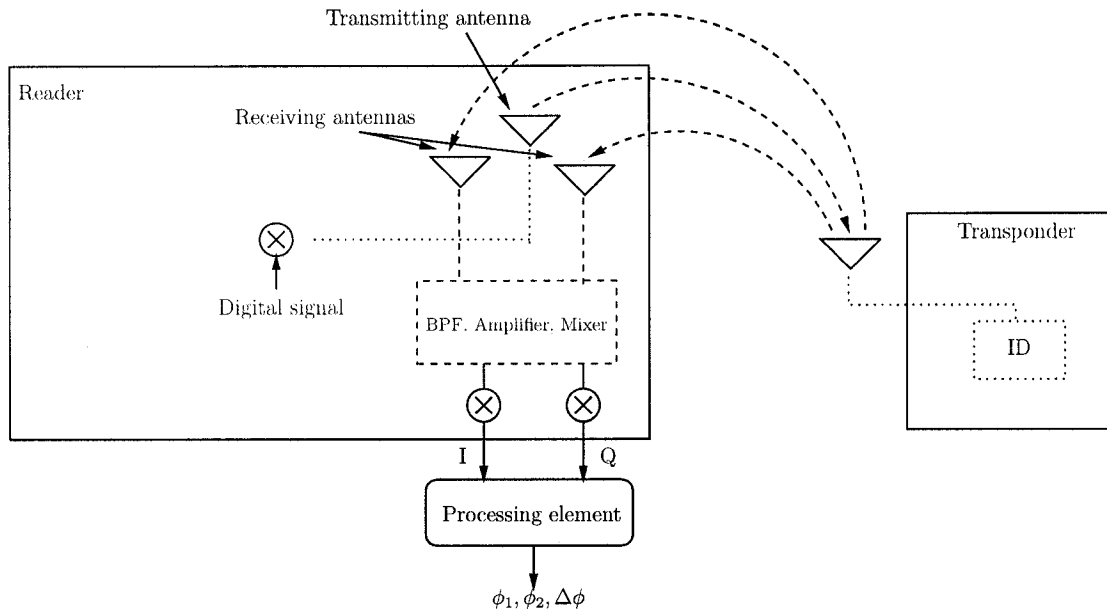

Figure 4.5: RFID system setup to compute the phase difference.

between pre-processing and post-processing blocks. We explain next each of these functional components with respect to the proposed navigation system.

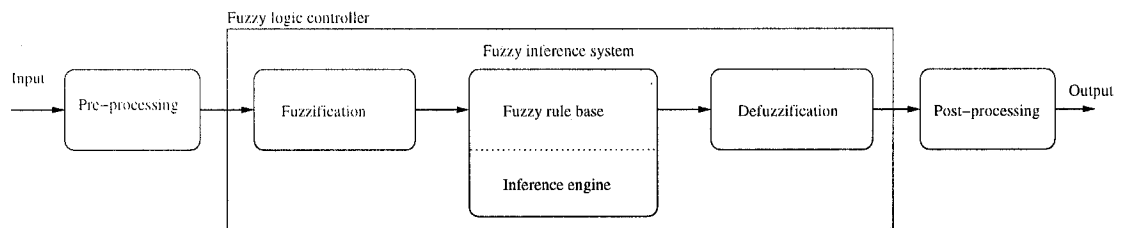

Figure 4.6: Different blocks of a fuzzy logic controller.

Most often, the inputs to the system are crisp measurements from some measuring components, rather than linguistic. A *pre-processing* unit applies some conditions, such as quantization, normalization or scaling, on observed measurements before they are fed into the controller. The measurement of the current navigation system is the phase difference which is normalized between  $-180$  to  $+180$  degrees.

The first block in the FLC is the *fuzzification* block, which transforms each input value from a crisp numerical value to a degree of membership through membership functions. The FLC used in our design is a single-input single-output system as shown in Figure 4.7. The FLC's input is the phase difference,  $\Delta\phi$ , provided by the two receiving antennas of

the RFID reader mounted on the robot. Three input and three output membership functions are used, as illustrated in Figure 4.8. The labels *CW* and *CCW* refer to clockwise and counter-clockwise, respectively.

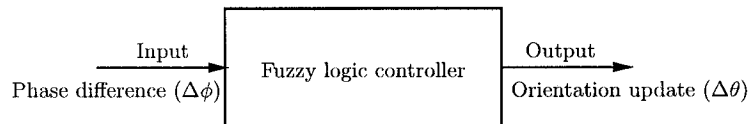

Figure 4.7: FLC model used by the mobile robot.

The second block of FLC, which is the *inference system*, has two essential components: the fuzzy rule base and the inference engine. The rule base consists of a set of IF-THEN rules that incorporate the human knowledge. Three fuzzy rules are then defined to reflect the fact that the phase difference of the signal is positive when the transmitting transponder is to the right of the reader and vice versa. These rules are defined as follows:

**If**  $\Delta\phi$  is *Neg*    **Then**  $\Delta\theta$  is *CCW*  
**If**  $\Delta\phi$  is *Zero*    **Then**  $\Delta\theta$  is *Zero*  
**If**  $\Delta\phi$  is *Pos*    **Then**  $\Delta\theta$  is *CW*

The rationale behind these rules is that the robot is supposed to turn left or right (CCW or CW) if the RFID tag is on the left ( $\Delta\phi < 0$ ) or right ( $\Delta\phi > 0$ ) of the reader. The second part of the fuzzy inference system is the inference engine. The most commonly used inference models are the Mamdani Fuzzy Model and the Sugeno Fuzzy Model. In here, a Mamdani mode is used, thanks to its intuitivity.

The *defuzzification* component of the FLC is responsible for converting the fuzzy set resulting from the inference process to a crisp numerical value that can be sent to the processor as control signal. The defuzzification method used in the current navigation system is the Centroid of Area (COA) method due to its satisfactory performance. The robot has to apply this  $\Delta\theta$  to its direction  $\theta$  to converge to its target position. The robot then uses this information to update its direction following the update rule (4.3).

$$\theta^{(\text{new})} = \theta^{(\text{old})} + \Delta\theta \quad (4.3)$$

The *post-processing* block is relevant to the system as well. In case the output is defined on a standard universe this must be scaled to engineering units. The post-processing block often contains an output gain that can be tuned to best fit the application in hand.

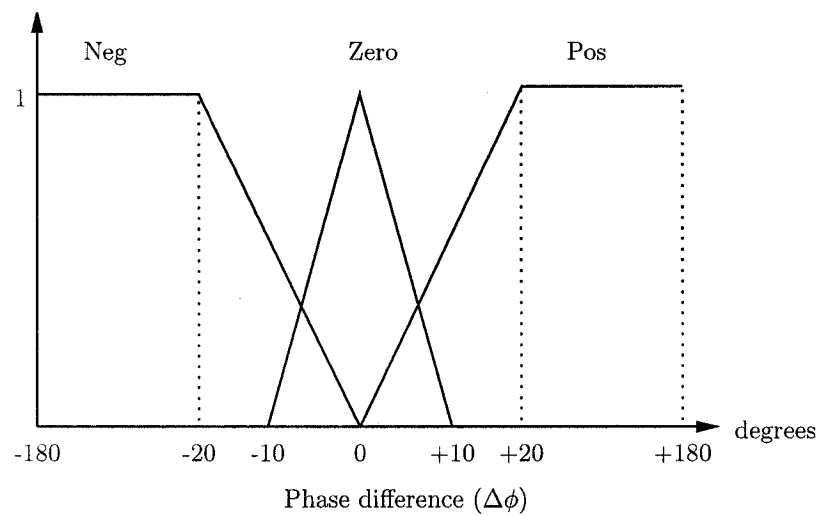

(a)

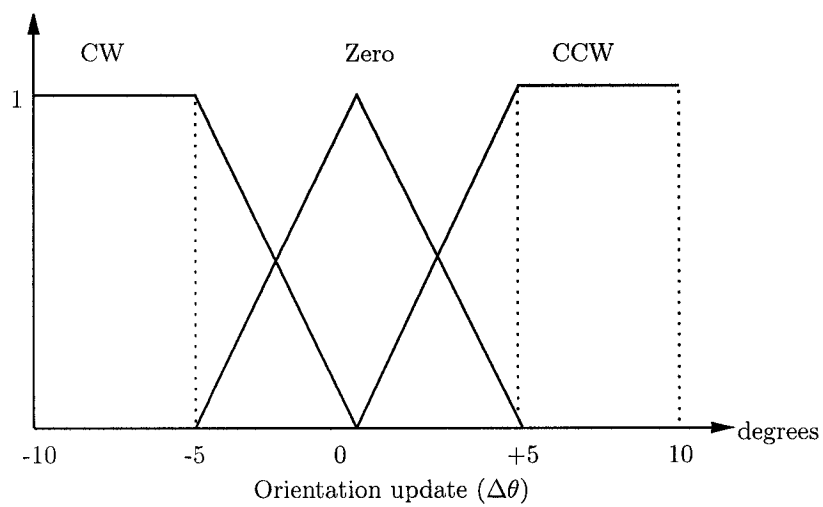

(b)

Figure 4.8: (a) Input and (b) Output membership functions.

## 4.4 Navigation Algorithm

We now explain how the modules described above fit into the overall navigation framework. A navigation algorithm is needed to act as a supervisory control layer to process and coordinate the efforts of the RFID communication module and the FLC, on one hand, and to pass the FLC's output control actions to the robot's relevant actuators, on the other hand. The flowchart of the navigation algorithm is provided in Figure 4.9. The following is a description of the different steps of the algorithm.

**Step 1:** The robot is pre-programmed with an ordered list of tag ID numbers defining its desired path.

**Step 2:** The target tag of the current navigation phase is determined from the ordered list of tags defining the complete robot's desired path.

**Steps 3 and 4:** Once the target tag is known, the robot scans through the signals backscattered from all the tags within the communication range and records the phase angles  $\phi_1$  and  $\phi_2$  of the signal coming from the tag representing the target transponder at that time instant.

**Step 5:** The phase difference of the destination tag's signal is then calculated as defined in (4.2).

**Steps 6 and 7:** In these steps, the phase difference is passed to the FLC (described in section 4.3.2) to quantize the tuneup the robot has to apply to its direction to better direct itself towards its destination. The robot then updates its heading by  $\Delta\theta$  by dispatching the required control action to its relevant actuators.

**Step 8:** The robot checks if the destination tag is reached. This can be accomplished in various ways. Checking the target tag's signal strength is one option. This can also be done by placing very short-range RFID tags on the floor under each long-range tag used to define the robot's target. Like that, the robot becomes aware that it reached its destination if its RFID reader detects the signal sent by the short-range tag. This is the method used in the simulations of section 4.5. Although this method is easy to implement, it restricts the algorithm's portability to fully-controlled environments only. For this reason, we are also investigating other techniques that can be used in this step. In case it is found that the destination tag is not reached yet, the algorithm restarts this inner loop beginning from Step 3.

**Step 9:** Once the path's current destination is reached, the robot checks if that was the last tag in the path. If not, then the algorithm passes the control back to the first step in this outer loop, Step 2.

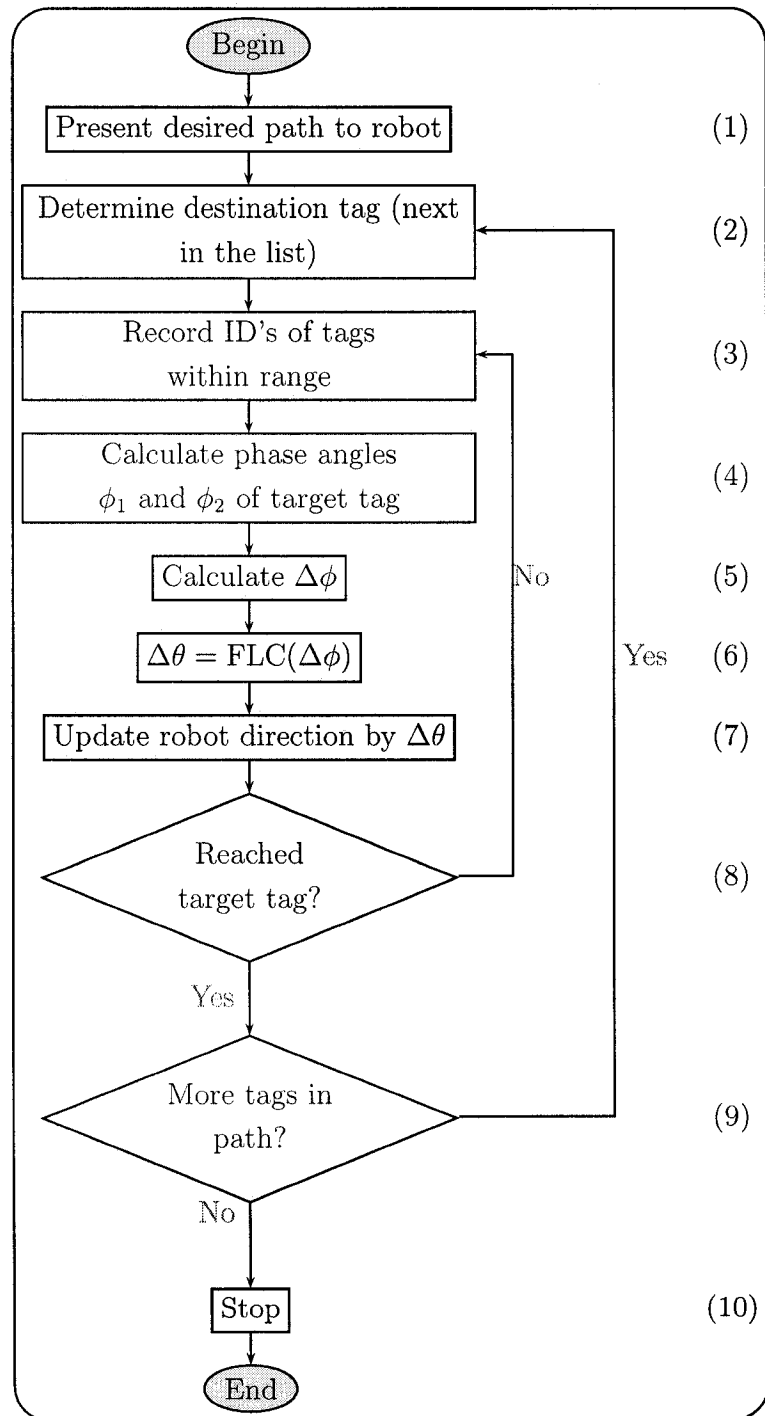

Figure 4.9: Flowchart of the proposed mobile robot navigation system.

A thorough evaluation of this algorithm’s performance is provided in the following section.

## 4.5 Experimental Results

Before presenting the experimental results, we now focus on defining the environment and several parameters of the mobile robot that are employed to evaluate the suggested algorithm. The proposed navigation scheme is carried out for a standard specified mobile robot through numerical computer simulations. The simulations are conducted using the 3-D simulation platform Simbad<sup>1</sup>. The environment considered in the simulation is an external obstacle-free workspace with a 3-m height ceiling with all the tags attached to it. A circular shaped mobile robot is used with 0.5 m height and 0.3 m radius. The robot’s rotational and translational velocities are set to 0.4 rad/s and 0.2 m/s, respectively. The operating frequency of the RFID system is 960 MHz with the read range of about 10 metres. An ordered sequence of tag IDs is stored in the robot’s memory before running each experiment.

### 4.5.1 Testing the Effect of the Robot’s Initial Position and Orientation

To evaluate the performance of the proposed navigation algorithm, we conducted three sets of numerical experiments. The first set of experiments aims at evaluating the algorithm’s ability in guiding the robot to reach its destination regardless of its initial position and orientation. This set of experiments is composed of three tests where the robot’s initial direction is set to 90, 45, and 0 degrees on the trigonometric circle centered at the origin. The experimental setup of these experiments is depicted in Figure 4.10. An RFID tag is mounted on a 3 m-height ceiling at location  $(x, y, z)^T = (0, 5, 3)^T$  m and the robot is placed at  $(x, y, z)^T = (0, 0, 0)^T$ , where the  $z$ -axis denotes the altitude. This makes the robot’s target position on the ground to be at  $(0, 5, 0)^T$  m. The results of these experiments are revealed in Figure 4.11. The outcome of the experiments show that the proposed algorithm is indeed successful in driving the robot towards its destination regardless of its initial position and direction. In particular, it is important to notice how in the experiments where the robot’s initial direction is 45 and 0 degrees (Figures 4.11(c),

---

<sup>1</sup><http://sourceforge.net/projects/simbad>

4.11(d), 4.11(e), and 4.11(f)), the algorithm detected the fact that the robot was initially diverging from the target, so it tuned its direction accordingly to reach its destination.

### 4.5.2 Assessing the Robot's Trajectory Tracking Ability

The second set of experiments is meant to assess the algorithm's ability to guide the robot to navigate along a desired trajectory. The configurations for these experiments are shown in Figures 4.12(a) and 4.12(b), with an initial orientation of 90 and 0 degrees where two tags,  $Tag_1$  and  $Tag_2$ , are mounted on the ceiling at (0,0,3) m and (0,5,3) m, respectively. The robot is set to start at position (-2, -2, 0) m with an initial orientation of 90 degrees. In this configuration, the robot's mission is to navigate from  $Tag_1$  to  $Tag_2$  along the straight line linking them (see Figures 4.13(a) and 4.13(b)). This can be regarded as a two-phase mission. In the first phase, the robot tries to reach  $Tag_1$  from its initial position. Then, in phase 2, the robot tries to move towards  $Tag_2$  following the desired trajectory. In this phase, the distance between the robot and its desired path is adopted as an error measure of the algorithm (see Figures 4.13(e) and 4.13(f)). The error sign indicates the side on which the robot is located with respect to the desired path. To study the effect of the robot's initial direction on the algorithm's performance, this experiment is repeated with an initial heading of zero degrees. The results of both experiments are demonstrated in Figure 4.13. As shown in Figures 4.13(c) and 4.13(d), the first phase of both experiments confirms what was shown in the first set of experiments (4.5.1) in that the robot always finds its way to its destination, *i.e.*,  $Tag_1$  in this case. Figures 4.13(e) and 4.13(f) also demonstrate that once the robot is in the vicinity of the starting point of its desired trajectory, it is capable of following this trajectory with a satisfactory error. The maximum recorded error in this phase for the first and second experiments is right at the start of that phase. It is also important to notice how this error decreases in magnitude as the robot moves along.

### 4.5.3 Testing a Complex Desired Path

The third and last experiment in this series is conducted to evaluate the algorithm's performance in guiding the robot to follow a desired complex path. In this experiment, the robot's desired trajectory is defined by four RFID tags mounted on the ceiling at different distances from each other, as shown in Figure 4.14. The actual and desired trajectories are depicted in Figure 4.15(a). The robot's initial position is at the origin (right under  $Tag_1$ ) while heading towards  $Tag_2$ . The algorithm's performance in this test

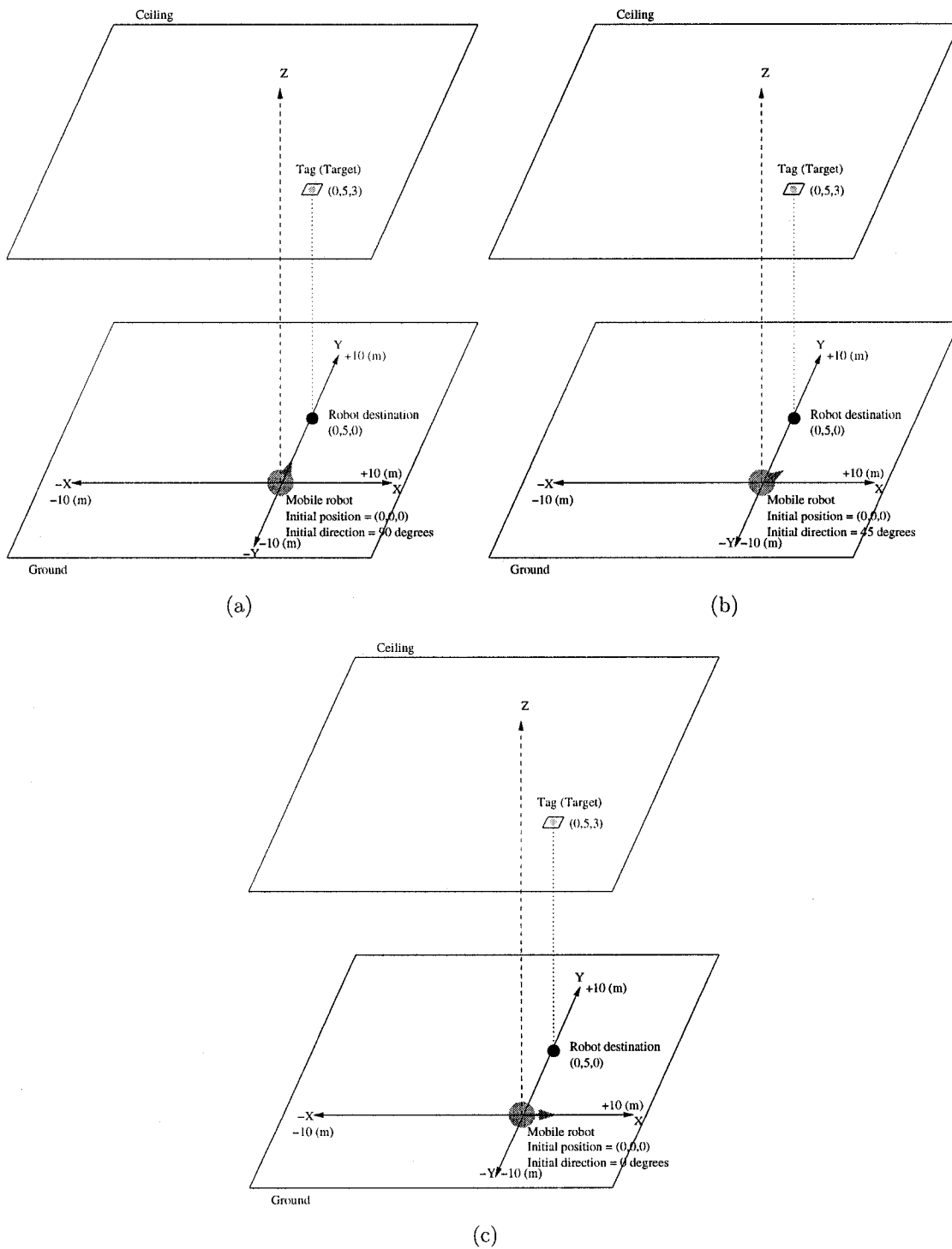
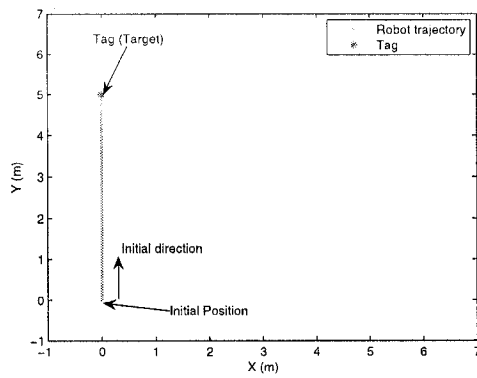

Figure 4.10: Experimental setup for testing the effect of initial position and orientation.

Robot's trajectory  
in X-Y plane



(a)

Distance between  
robot and target

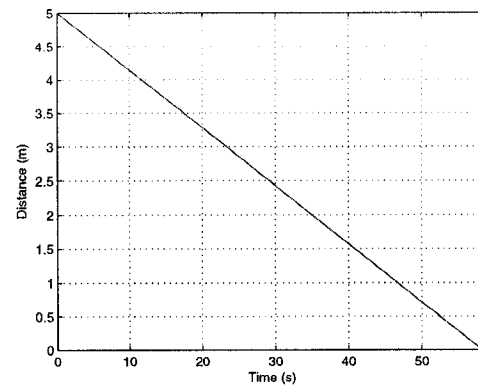

(b)

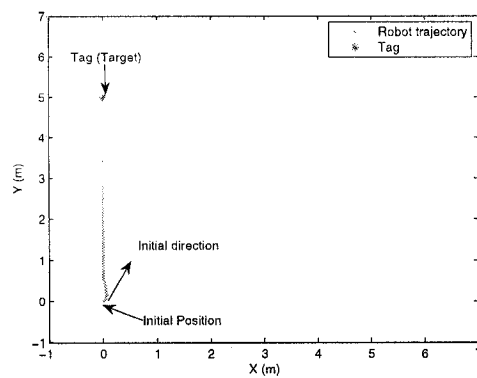

(c)

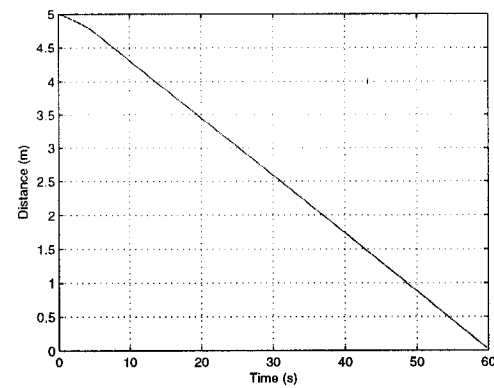

(d)

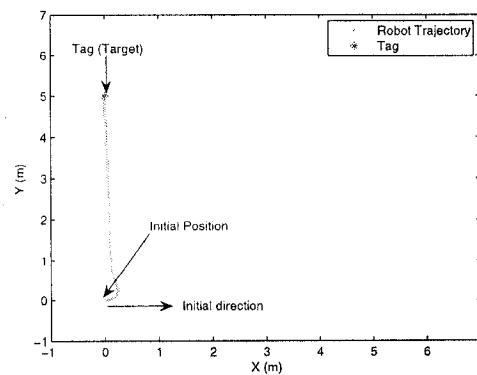

(e)

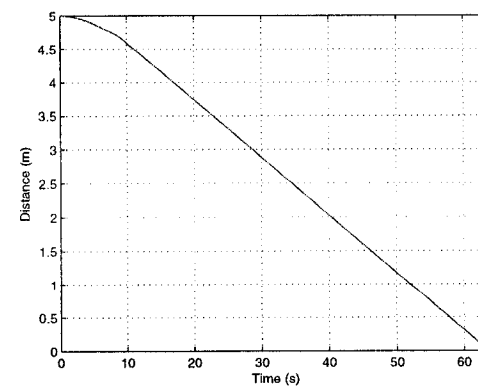

(f)

Figure 4.11: Proposed algorithm's performance in reaching a target location with an initial orientation of (a) and (b) : 90 degrees; (c) and (d) : 45 degrees; (e) and (f) : zero degrees.

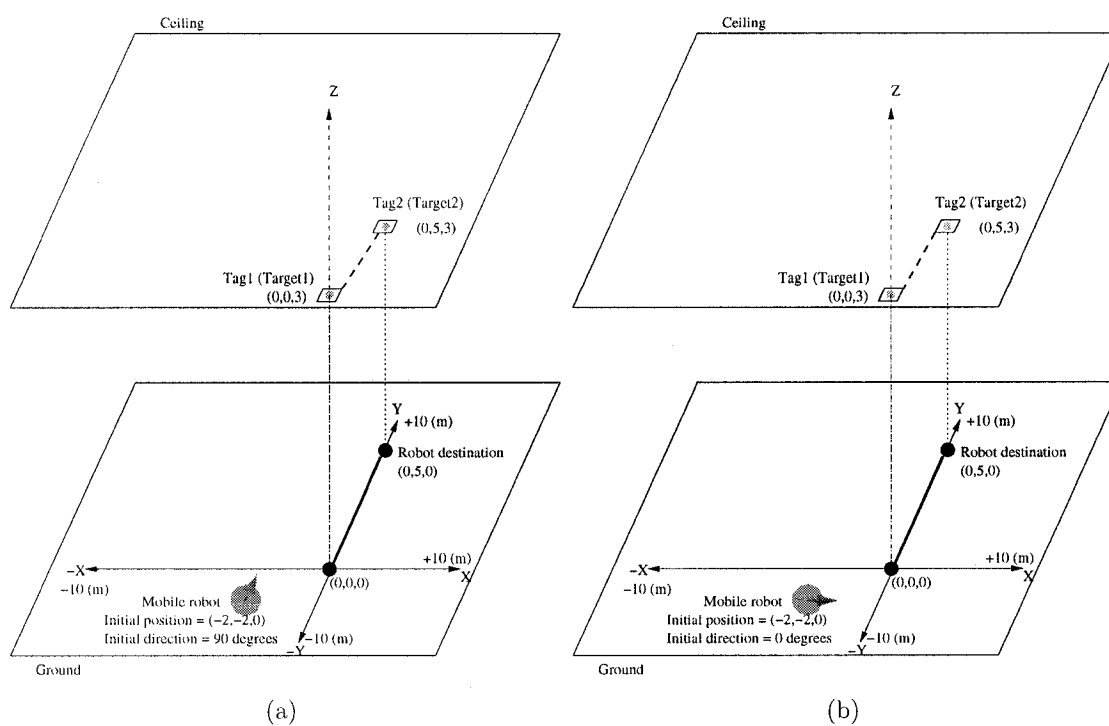

Figure 4.12: Experimental setup for assessing the robot's trajectory tracking ability.

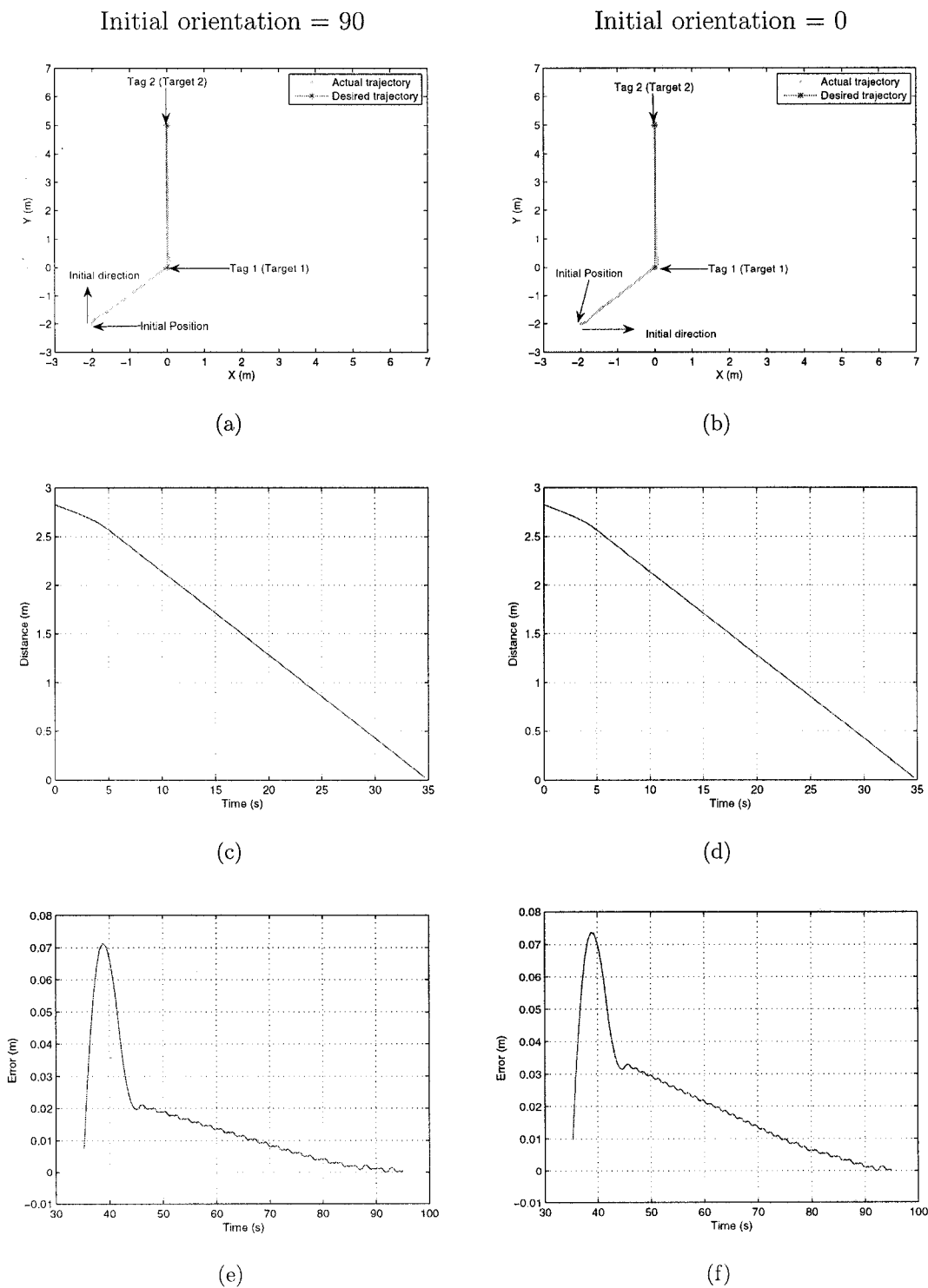

Figure 4.13: Proposed algorithm's performance in reaching a target location and following a desired rectilinear path. (a) and (b) : robot's trajectory; (c) and (d) : robot approaching its first destination tag (phase 1); (e) and (f) : error in following the robot's desired trajectory (phase 2).

is illustrated in Figure 4.15. The robot's ability to autonomously converge and remain on its desired trajectory regardless of its length and complexity is well demonstrated in this experiment. As can be seen, the error tends to increase at the path's corners. This is natural since it takes some time for the robot to realize that it started to diverge from its target and adjusts its direction accordingly. As a result, and shortly after that, the robot cruises back to the desired trajectory and the error quickly converges to a slim acceptable margin. This behavior confirms the robot's performance in the second set of experiments since it represents a special case of this experiment.

## 4.6 Summary

In this chapter we described an efficient approach for mobile robot navigation. The key idea of this approach is to make use of some analogue features of the RFID reader and apply them as a means of navigation media. First of all, the reader mounted on the robot broadcasts signal to get some ordered lists of IDs from the transponders placed at the ceiling in its operating region. The robot considers one of the IDs as current destination and uses the phase difference of the signals backscattered by that tag ID and received by both antennas on the reader. A customized RFID reader architecture is needed to compute the phase difference since commercially available readers do not provide it. The fuzzy logic controller makes use of this phase difference to provide the appropriate control actions to the actuators to assist the robot in moving towards the target tag. Once the robot reaches the first target tag, it receives the next tag ID from the list, and calculates the phase difference to navigate accordingly. This process continues until the robot arrives at its final destination, whereby it stops. The experimental results show the successful realization of the proposed technique. In the next chapter we will propose another navigation algorithm using a customized RFID tag architecture.

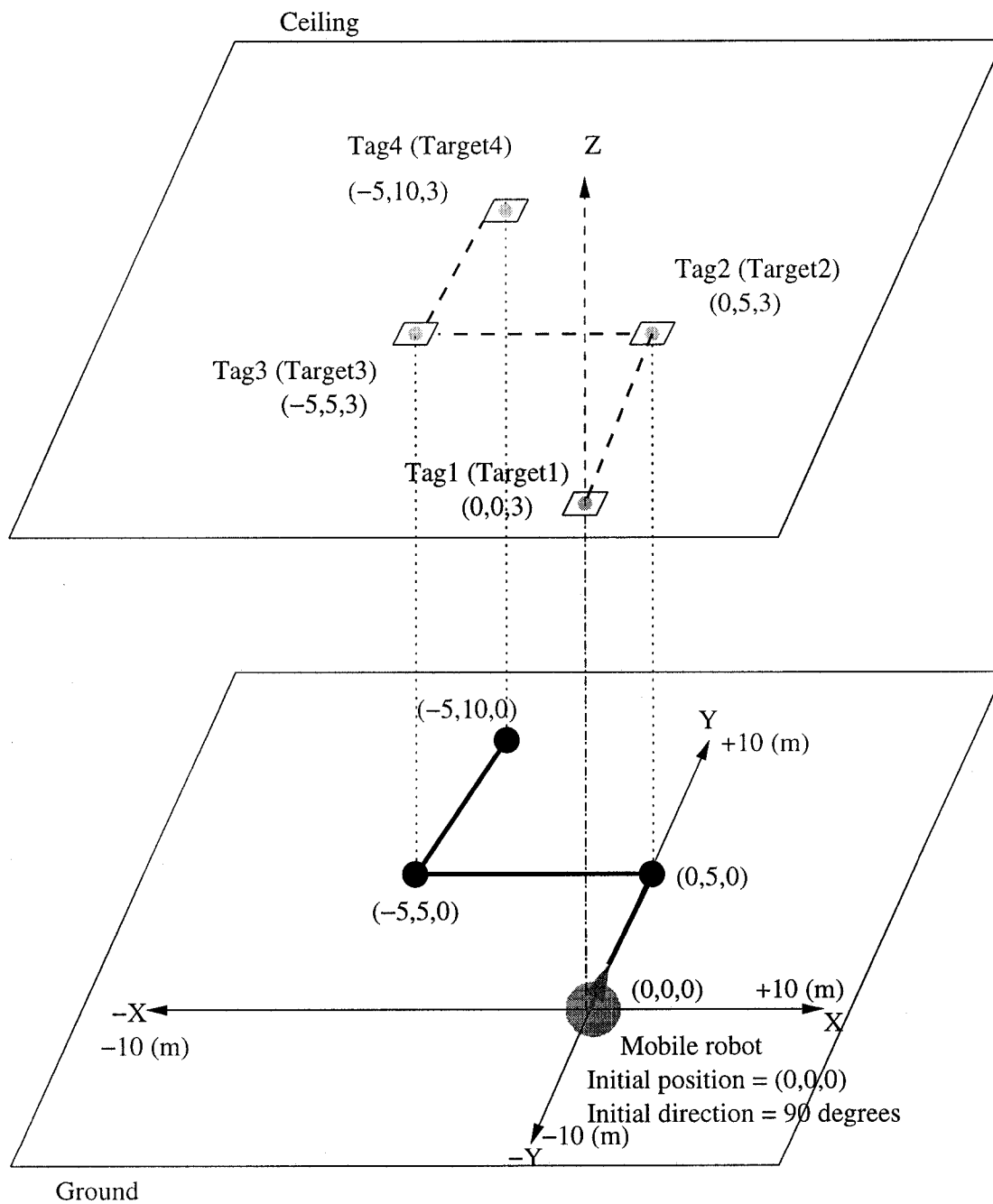
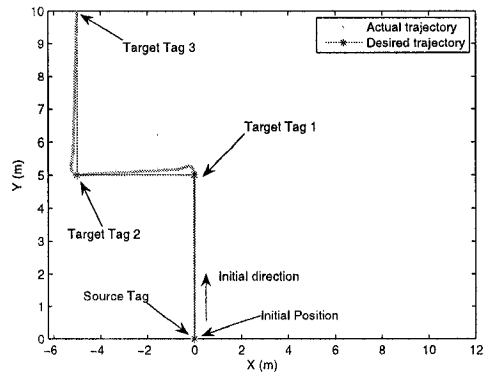
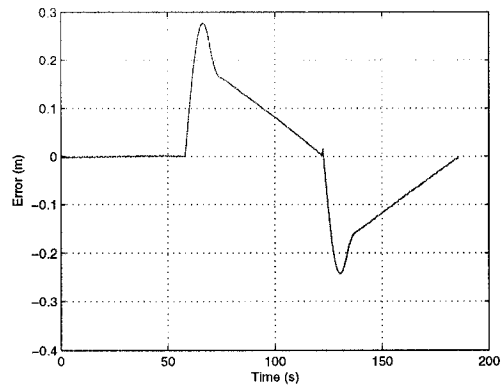

Figure 4.14: Experimental setup for testing a complex desired path.



(a)



(b)

Figure 4.15: Proposed algorithm's performance in following a complex desired path. (a) robot's trajectory; and (b) error in following the complex path (distance between the robot and its desired path).

# Chapter 5

## Navigation Using Customized RFID Tag

### 5.1 Introduction

In the previous chapter we presented a navigation strategy which is based on a customized RFID reader architecture. Just like many existing approaches, our previous navigation algorithm has some shortcomings. It is often hard to guide the robot with accurate realization of the phase difference of the received signal at the reader. Sometimes the phase difference provides erroneous information to the robot's actuator and making it diverge from the desired trajectory. However, this technique has an obvious advantage that it does not depend on a complex mathematical model of the robot nor its working environment. In this chapter we examine another navigation strategy for guiding a robot using a customized RFID tag architecture. In the current approach, the guiding principle of the robot is based on the trilateration of the signals backscattered by the RFID tags in range. The performance of using fuzzy logic controller in the present navigation scheme is also compared with a conventional controller in terms of navigation accuracy and tracking error.

In the next section we discuss how the RFID tag architecture can be customized for this purpose. After introducing a general framework for the current navigation system in section 5.3, we describe the different submodules of this system in the subsequent sections. The key steps of the implementation are illustrated in section 5.4. We support our approach with a number of computer simulation results in section 5.5, followed by a discussion on the system's accomplishments.

## 5.2 Customized RFID Tag Architecture

The tag architecture presented in this chapter has some distinguishing characteristics from the tags available on the market. A simplified RFID system with customized tag architecture is illustrated in Figure 5.1. Usually, the radio frequency (RF) transceiver on the reader illuminates a short pulse of electromagnetic waves. The transponder receives the RF transmission, and then rectifies the received signal in order to get the DC power (what is called herein Tag Received Power (TRP)) supply for the IC memory in the tag circuitry. In the present customized RFID system, the transponder should have some processing capability so that it can convert the received power, TRP, into a 32-bit information. The memory of the transponder is responsible for storing a frame of 40 bits which has mainly two parts: a tag ID, and TRP. The 8-bit tag ID ensures that the environment has 256 distinct transponders among which the robot can cooperate while navigating in its workspace. The 32-bit (1 bit for sign, 15 bits for integer part, and 16 bits for fraction part) TRP is able to assist calculating the approximate line-of-sight distance between the transponder and the reader. The transponder modulates the 40-bit frame and backscatters in response to the interrogation of the reader. The signal generated by the transponder is then received by the reader to extract the frame. Note that no customization is required for the reader as it would read the 40-bit frame in exactly the same way as it normally reads RFID tags. The 40-bit frame as read by the reader will then be processed by the processor on the robot's board to decode it into a tag ID and a TRP component. The TRP will then be used to approximate the distance between the tag with the decoded ID and the robot. In the current work we are particularly interested in determining the robot's position based on the line-of-sight distance which is computed from the TRP in the frame. The details of how to calculate the position of the robot will be described later.

## 5.3 Navigation System Architecture

The general high level architecture of the navigation system suggested in this chapter consists of an RFID communication module, a robot positioning system, and a fuzzy logic controller. The RFID communication module is responsible for communicating between the robot and the transponder. The robot positioning system determines the absolute position of the robot in the world coordinate system. After determining the current position, the robot calculates the desired angle between itself and the current

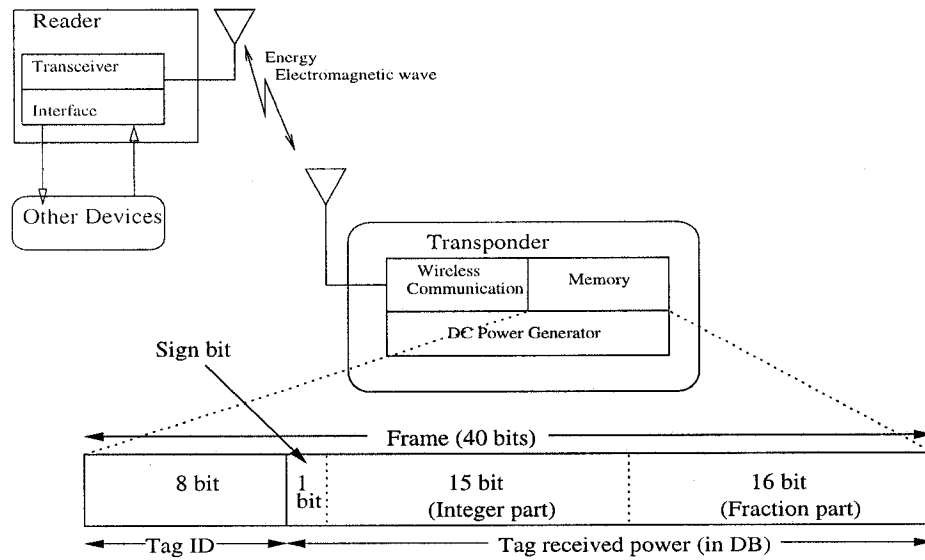

Figure 5.1: A simplified RFID system with customized tag architecture.

target to be reached. The desired angle is then fed to the FLC to provide necessary control actions to the actuators of the robot.

Figure 5.2 shows the system configuration with three tags attached on the ceiling and an RFID reader mounted on the robot. The robot's desired trajectory is a straight pathway along the orthogonal projection points of the tags, A, B, and C. Without loss of generality, let us consider a scenario where the robot is presented with a desired trajectory that is defined by an ordered sequence of tag IDs, 1, 2, 3. The robot first navigates to the orthogonal projection point of the tag with ID 1, then it moves along the virtual straight line linking the orthogonal projection points of tags 1 and 2. Once the robot reaches the point under the tag with ID 2, it follows the same procedure to arrive at the orthogonal projection point under the tag with ID 3. This scheme is applicable to more than three tags (more details in section 5.5). The novelty of our navigation scheme is that it is independent of odometry information and structure of the working environment. The proposed navigation method also offers a certain degree of fault tolerance to the system *i.e.*, if any of the transponders failed to work, then the robot can still navigate by coordinating with other three transponders in the environment. It is important to stress the fact that in this navigation scheme, the robot's desired trajectory does not have to be right under the tags. At least three RFID tags are needed for navigation, and more if the algorithm is to be fault-tolerant. The tag positions do not need to be known to the robot if the desired trajectory is defined with respect to them. However, they are needed

if the desired trajectory is given in the world coordinate system.

We now explain the RFID communication module, robot positioning system, and fuzzy logic controller.

### 5.3.1 RFID Communication Module

Basically, the RFID communication module consists of three parts: the transponder, reader's interface, and robot's processing unit, as shown in Figure 5.3. At every pre-defined time interval, the robot broadcasts an analogue signal which is received by the transponder(s) in its operating region. The transponder extracts that signal and converts it into TRP which is then combined with its ID to construct a frame. Then, the stored frame is transmitted back to the reader. The RFID reader's interface is responsible for decoding the received frame and extracts the relevant information as needed.

### 5.3.2 Robot Positioning System

Before starting the mission, the robot is presented with an ordered list of virtual points on the ground specifying its desired path. The coordinates of such points can be expressed either in the world coordinate system or in the tag coordinate system. The robot approximates its position by extracting and decoding the frames backscattered by at least three of the RFID tags in range. The TRP is converted into a distance measure between the transponder and the robot before trilateration is applied to locate the robot. This mechanism is illustrated in Figure 5.4.

Once the robot's position is computed, the angle  $\phi$  between its current position and its immediate desired target position (in that phase) is determined by (5.1),

$$\phi = \phi_1 - \phi_2, \quad (5.1)$$

where  $\phi_1$  and  $\phi_2$  are the robot's current orientation and the angle of the target point, respectively. This is illustrated in Figure 5.5.

In a real-world RFID system, the TRP is computed through an analogue circuit embedded in the tag. In here, we are simulating the calculation of the TRP using the model defined by (5.2),

$$TRP = P_r = P_t G_t G_{Tag} \left( \frac{\lambda}{4\pi D} \right)^2 = P_{EIRP} G_{Tag} \left( \frac{\lambda}{4\pi D} \right)^2 \quad (5.2)$$

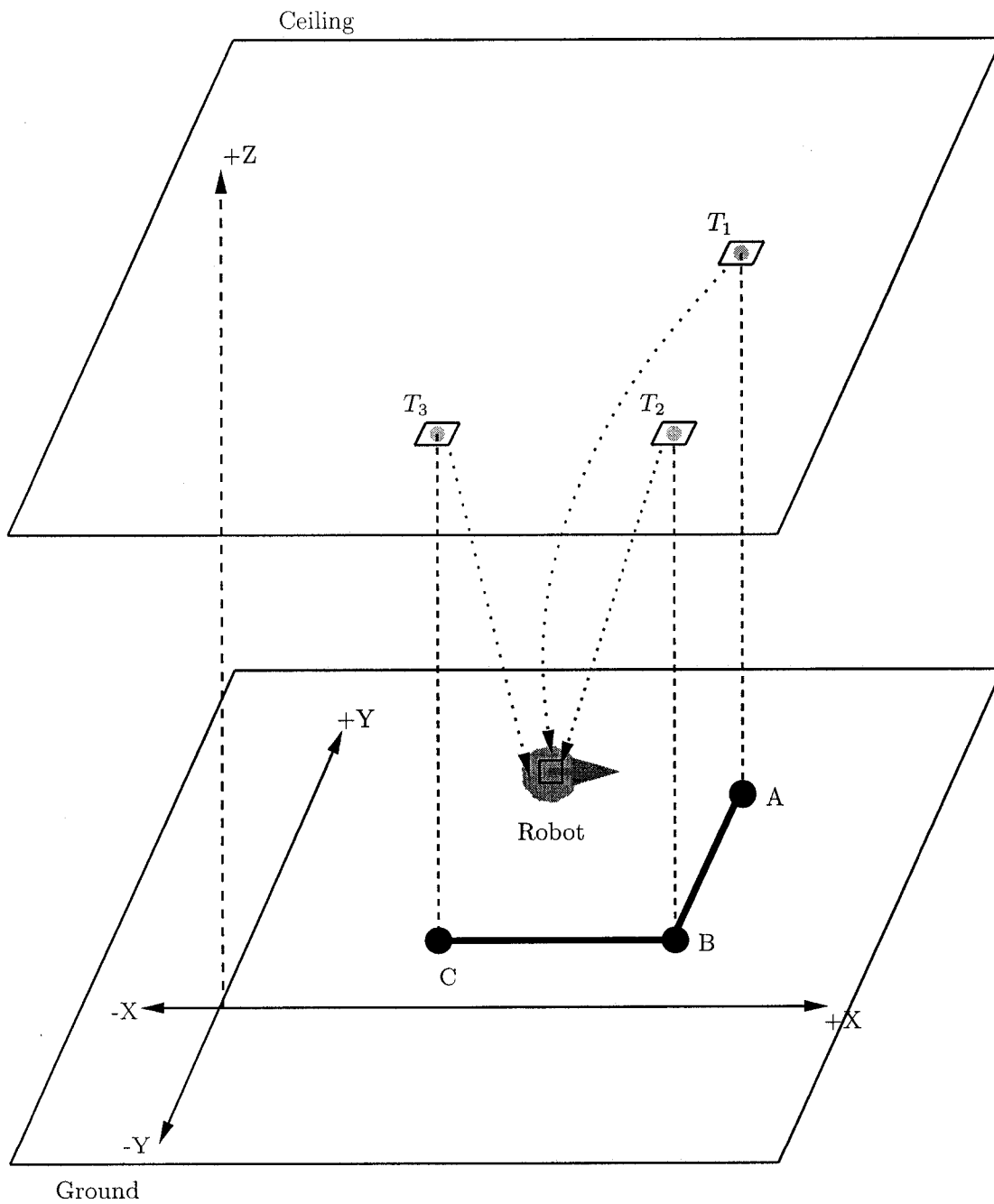

Figure 5.2: High-level system configuration with three RFID tags.

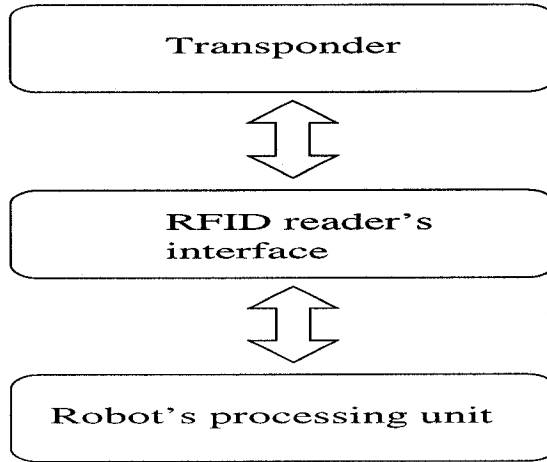

Figure 5.3: RFID communication module.

where  $P_t$  and  $P_{EIRP}$  are the transmitted power and Effective Isotropic Radiated Power (EIRP) by the reader, respectively;  $G_t$  and  $G_{Tag}$  are the antenna gains of the reader and tag, respectively;  $\lambda$  is the wavelength; and  $D$  is the shortest distance between the reader and the tag [17]. Model (5.2) considers an ideal TRP signal where the noise effect is neglected. A more realistic expression for TRP is given in equation (5.3), in which case RF signals are contaminated by external noise and reverberations.  $G_0$  and  $G_i$ 's are the antenna gains of the reader at different directions,  $r_0$  and  $r_i$ 's are the distances between the tag and reader,  $n$  is the number of rays along which reflected signals are coming from the different obstacles, and  $\Gamma(\alpha_i)$  represents the reflection coefficient of each ray,  $i$ .

$$P_r = P_t \left( \frac{\lambda}{4\pi} \right)^2 \left| G_0^{1/2} \frac{1}{r_0} \exp(-jkr_0) + G_i \sum_{i=1}^n \Gamma(\alpha_i) \frac{1}{r_i} \exp(-jkr_i) \right|^2 \quad (5.3)$$

### 5.3.3 Fuzzy Logic Controller

Similar to the algorithm presented in the previous chapter, the current system also employs a single-input single-output Mamdani-type fuzzy logic system. The aim of the fuzzy logic controller is to decide on the amount of tuneup,  $\Delta\theta$ , that the robot has to apply to its direction,  $\phi_1$ , to reach its target. The input of the fuzzy logic system is the angle,  $\phi$ , provided by the robot positioning system module (see Figure 5.6). The robot then uses the output of its FLC to update its direction following the update rule (5.4).

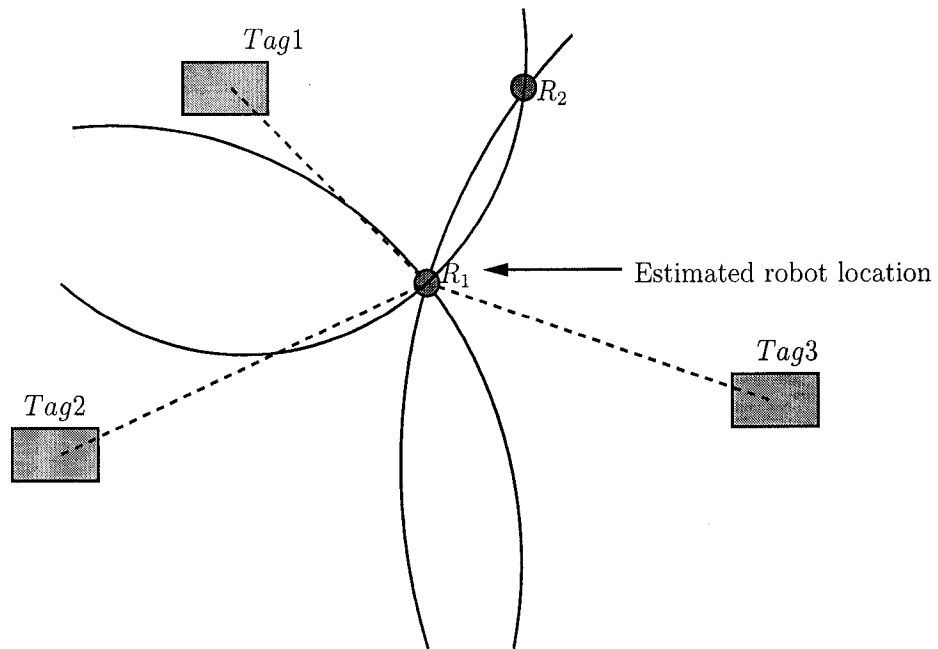

Figure 5.4: Positioning through trilateration.

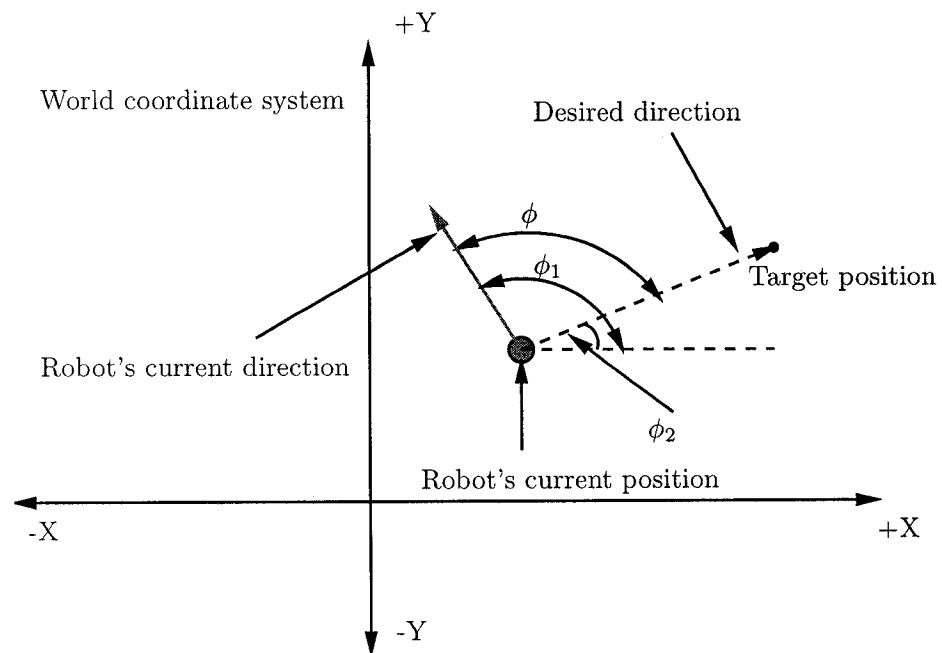

Figure 5.5: Calculation of angle between the robot and target.

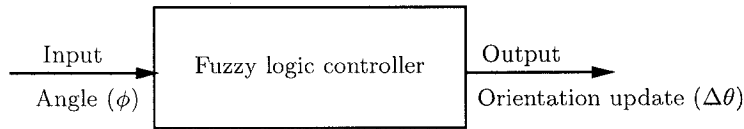

Figure 5.6: Fuzzy logic controller used to determine  $\Delta\theta$ .

$$\phi_1^{(\text{new})} = \phi_1^{(\text{old})} + \Delta\theta \quad (5.4)$$

The input and output membership functions used in this fuzzy logic system are similar to those defined in chapter 4 (section 4.3.2). Three fuzzy rules are defined to reflect the fact that the angle ( $\phi$ ) between the robot and the transponder is positive when the transmitting transponder is on the left side of the reader and vice versa. These rules are defined as follows:

**If**  $\phi$  is *Neg*    **Then**  $\Delta\theta$  is *CCW*  
**If**  $\phi$  is *Zero*    **Then**  $\Delta\theta$  is *Zero*  
**If**  $\phi$  is *Pos*    **Then**  $\Delta\theta$  is *CW*

An empirical analysis was performed to optimize these membership function parameters to improve the FLC's performance. The “min” and “max” operators are adopted as t-norm and s-norm operators, while the defuzzification method is chosen to be the center of area.

## 5.4 Navigation Algorithm

The proposed navigation algorithm is quite similar to the previous one presented in chapter 4 except that instead of using the phase difference, the current approach uses the desired angle to provide control actions to the robot's actuators to navigate from one place to another. Figure 5.7 shows the flowchart of the algorithm. The different steps of the algorithm are described below.

**Steps 1 and 2:** The robot is programmed in advance with an ordered list of destination points. From this list, the current destination point is determined.

**Steps 3 and 4:** The instantaneous position of the robot is computed from the TRPs of at least three tags using trilateration method. The angle  $\phi$  between the robot's current position and destination point is calculated using equation (5.1).

**Step 5 and 6:** This angle is dispatched to the FLC in order to compute the orientation

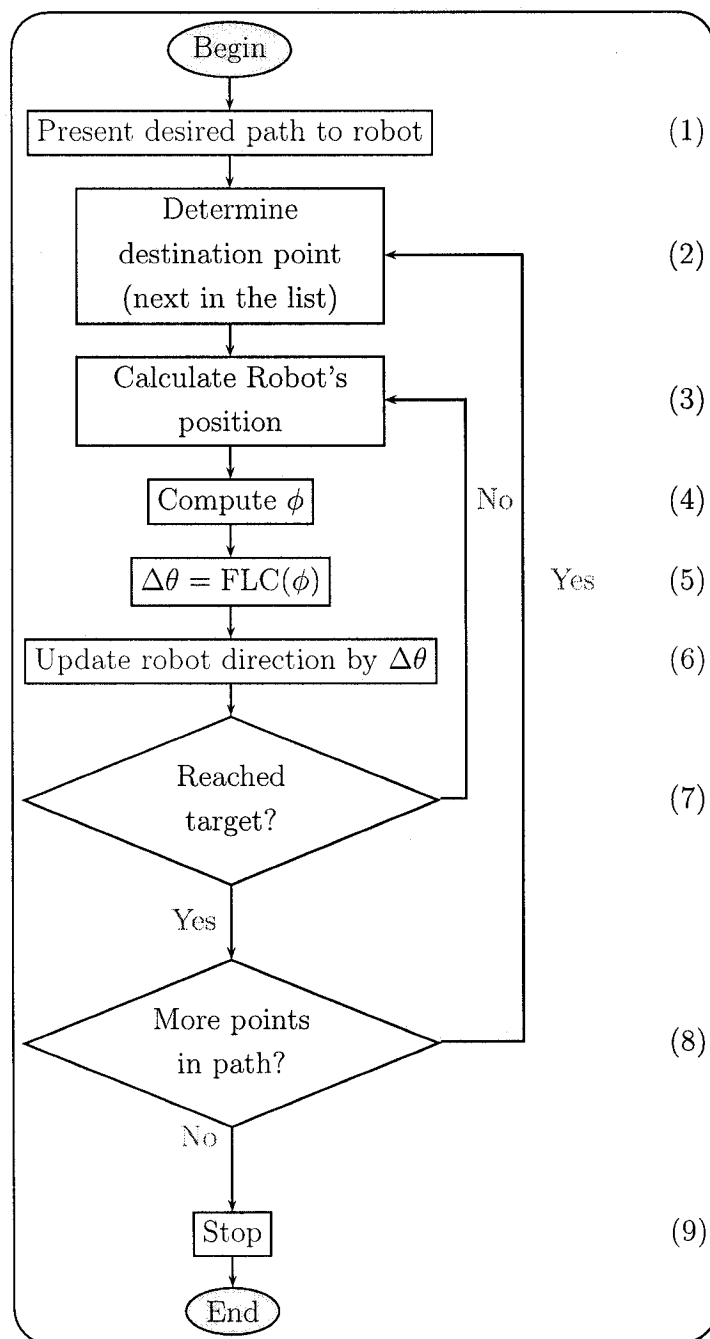

Figure 5.7: Flowchart of the proposed mobile robot navigation system.

tuneup  $\Delta\theta$ . The heading of the robot is then updated by  $\Delta\theta$ .

**Steps 7, 8 and 9:** Once the destination point is reached, the robot checks for more available points in the desired path. If the current destination is the last point in the path, then the robot simply stops navigation. If not, the algorithm passes its control back to step 2.

## 5.5 Simulations and Results

Two different experiments are conducted to evaluate the performance of the proposed navigation algorithm under various configurations. If the robot's initial position is not at the starting point of the desired path, then it will start by trying to reach that point. During this phase, the performance metric is the distance between the robot's position and the trajectory's starting point. Once the robot reaches the desired path's initial point, the performance measure becomes the tracking error between the actual and desired trajectories, as defined in Chapter 4. The operating frequency of the RFID system used in this algorithm is also 960 MHz.

### 5.5.1 Following a Two-Segment Path

This experiment is performed by setting the mobile robot at an initial position  $(x, y, z) = (-1, -1, 0)$  and initial orientation of zero degree in the world coordinate system. Three tags are placed at coordinates  $(0, 0, 3)$ ,  $(0, 3, 3)$ , and  $(-5, 3, 3)$  m. On the ground the desired path is defined as P1-P2-P3, where P1 =  $(0, 0, 0)$ , P2 =  $(0, 3, 0)$ , and P3 =  $(-5, 3, 0)$  m. The configuration of this experiment is shown in Figure 5.8. The line-of-sight distance  $D$  is calculated based on the TRP as defined by (5.2) in which no signal reverberation (e.g. from walls or ceiling) is considered, while receiving the power at the transponder. The values of  $P_{EIRP}$  and  $G_{Tag}$  are 825 mW and 1860.04, respectively. The actual and desired paths of the mobile robot are depicted in Figure 5.9(a). At first, the robot was diverging away then it tuned itself to head to P1. Figure 5.9(b) shows how fast the robot traveled towards P1 from its initial position. It took the robot about 18 seconds to come within 8cm of P1. The robot then performed a two-phase navigation.

In the first phase, it considers P2 as its destination and keeps navigating along the line segment connecting P1 and P2. The trajectory tracking error is shown in Figure 5.9(c) for the two phases of navigation of the mobile robot in this experiment. At the beginning, the robot was moving away from the desired line, P1-P2, so the tracking error was increasing

for about 5 seconds. Then it turned out a remarkable reduction of the tracking error until the robot reaches P2.

In the second phase of navigation, the robot was targeting to reach its final destination P3 and was starting to find the desired line segment connecting P2 and P3. The initial tracking error in this case was worse than that of the first phase. This is simply because, after reaching P2, the robot's current direction was 90 degrees with the line, P2-P3. At time  $\approx 65$  seconds, the robot realized that it was diverging from its desired path. This experiment confirms that the robot has the ability to autonomously track rectilinear trajectories in the absence of RF noise.

### 5.5.2 Following a Three-Segment Path

The objective of this experiment is to show the fault tolerance capability of the proposed navigation system when one of the tags fails. In order to demonstrate this fact, the robot is initially placed at  $(-0.5, -0.5, 0)$  m with an initial orientation of 270 degrees where the four tags are attached at positions  $(0, 0, 3)$ ,  $(0, 3, 3)$ ,  $(-5, 3, 3)$ , and  $(5, 2, 3)$  m, respectively (see Figure 5.10). This experiment is conducted with a more realistic RF signal where the TRP can be contaminated by the environmental noise. The original versus the noisy signal is plotted in Figure 5.11(a) and the corresponding signal-to-noise ratio (SNR) is shown in Figure 5.11(b). The values of the parameters of the equation (5.3) are  $P_t = 825$  mW,  $G_0 = 1860.04$ ,  $G_1 = 1850.04$  and  $\Gamma = 0.707$ , respectively. The noisy RF signal is filtered through an averaging time window of 1 second to approximate the TRP at every instant of time. Figure 5.12(a) shows that the robot is navigating along the lines linking points P1, P2, P3, and P4. In this case, the desired trajectory of the robot consists of three phases of navigation (one for each segment of the path). The robot computes its position based on the TRPs from Tag1, Tag2, and Tag3. Then, Tag1 is assumed to fail when the robot is between P2 and P3. Under this circumstance, in the third phase, the robot computes its position and navigates the rest of the path based on the TRPs from Tag2, Tag3, and Tag4. The robot's performance in this experiment is shown in Figure 5.12. As in the previous experiment, the robot was capable of tracking its desired path despite the noise in the RF signal. It is also worth noting from Figure 5.12(c) that the failure of Tag1 at time  $\approx 80$  sec. caused a practically negligible degradation in the robot's tracking error of a few seconds before the error resumed its convergence to zero.

The results of the above experiments ensure that the proposed navigation scheme successfully guides a mobile robot along a predefined trajectory regardless of its initial

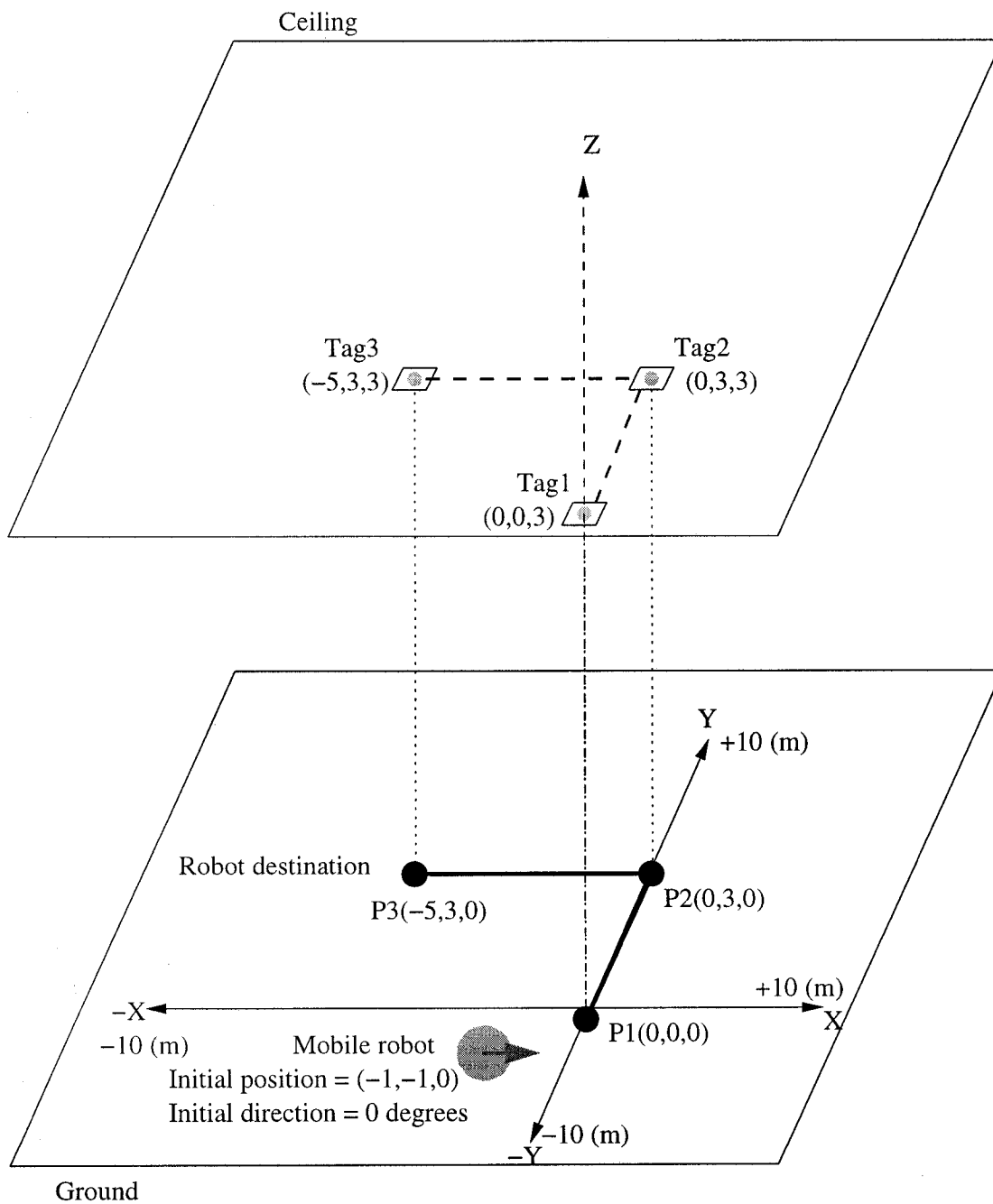
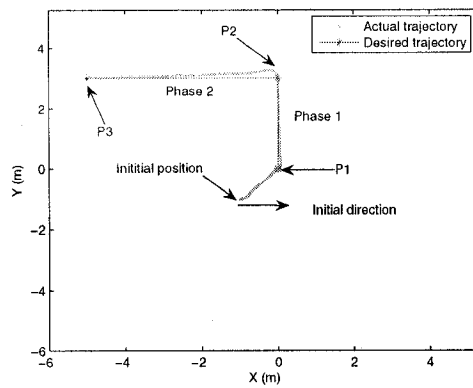

Figure 5.8: Experimental setup of a two-segment path.

Robot's trajectory  
in X-Y plane



(a)

Tracking error

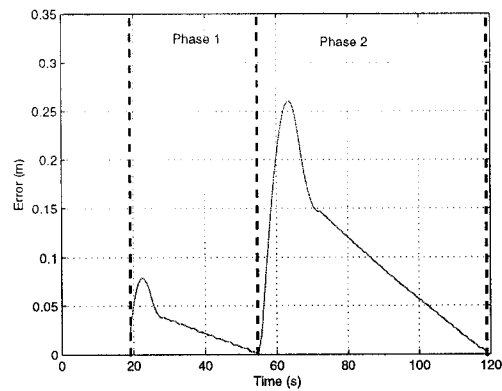

(c)

Distance between  
robot and P1

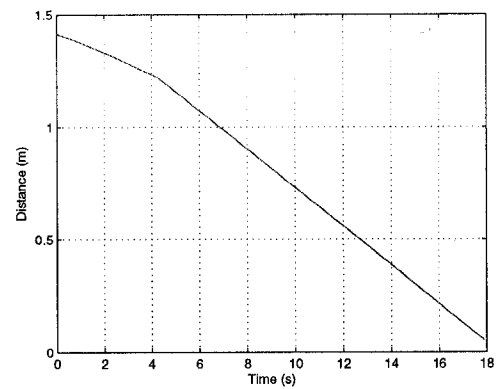

(b)

Tag Received Power (TRP)

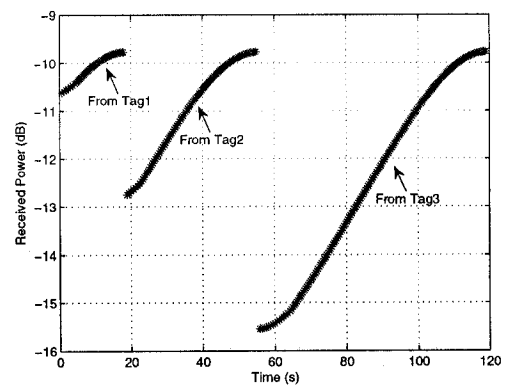

(d)

Figure 5.9: Performance of the proposed navigation algorithm on a two-segment trajectory.

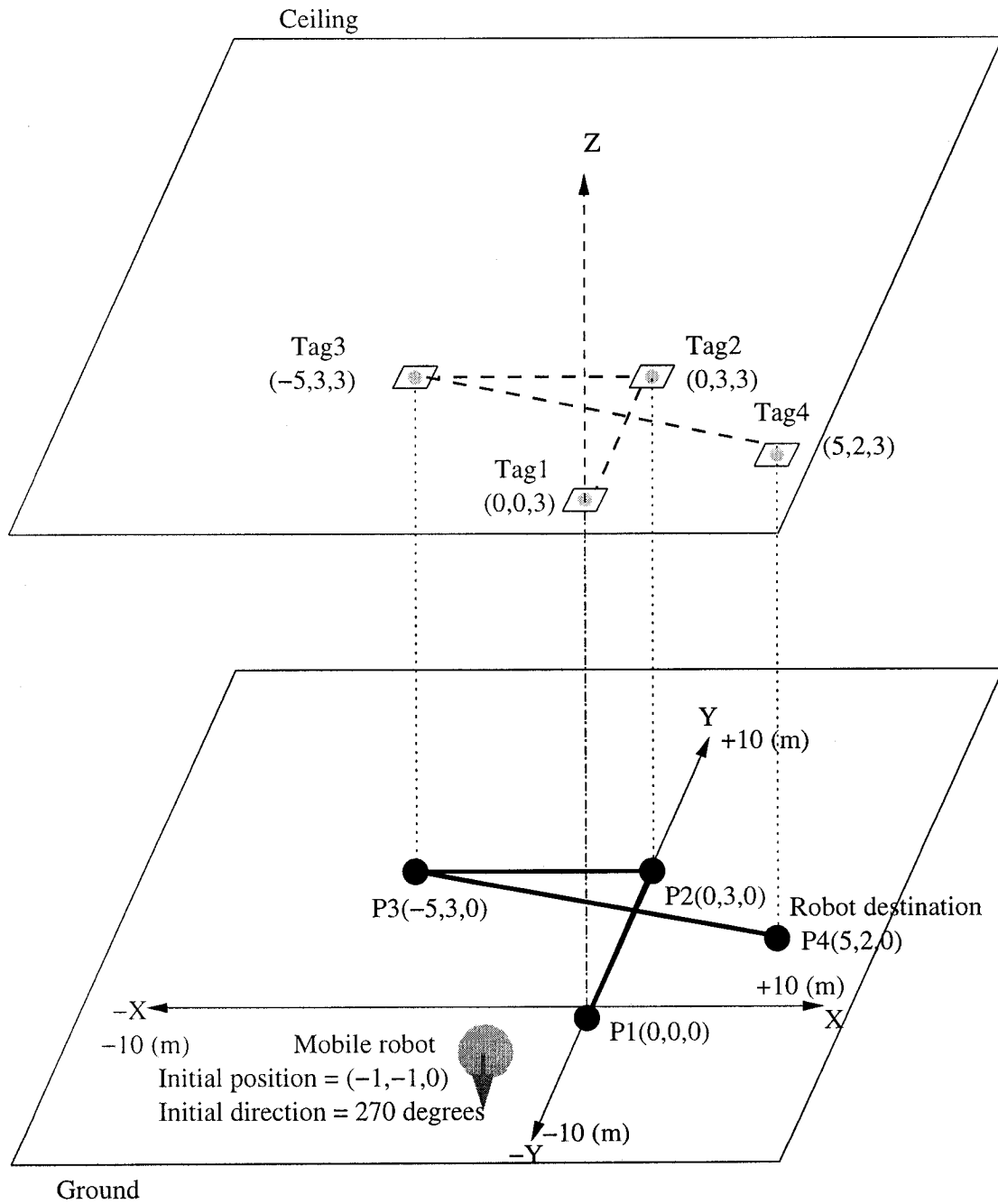

Figure 5.10: Experimental setup of a three-segment path.

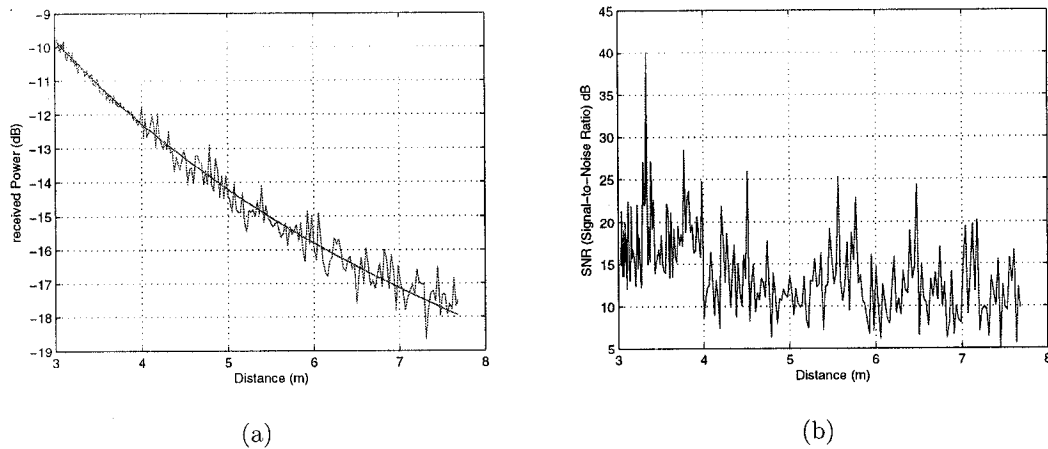

Figure 5.11: RF noise model (a) original vs. noisy signal (b) SNR.

position and orientation, length and complexity of the path in the work space, respectively.

### 5.5.3 Experiments Using a Conventional Controller

In order to justify the use of a fuzzy logic controller, the same experiments are also carried out to test the performance of the algorithm using a conventional proportional controller. In other words, instead of using a fuzzy logic controller to compute the robot orientation update angle  $\Delta\theta$ , it was calculated as (5.5). The value of  $K_p$  used in these experiments is  $K_p = 0.056$  and it was empirically optimized to provide the best possible performance.

$$\Delta\theta = K_p\phi \quad (5.5)$$

Figure 5.13(a) shows the actual and desired trajectory of the first experiment for a two-segment path. Similar to the previous experiments that we described earlier, the robot took some time to reach P1. Then it performs two phases of navigation. In the first phase, the robot keeps moving gradually along the desired navigation line, P1-P2, for a short period of time. Then it drastically diverges from its desired path which we can see from the tracking error in phase 1 (see Figure 5.13(b)) before it converged to the vicinity of P2. Then, the robot starts tracking the line linking P2 and P3 in the second phase of navigation producing larger fluctuations of the tracking error.

Robot's trajectory  
in X-Y plane

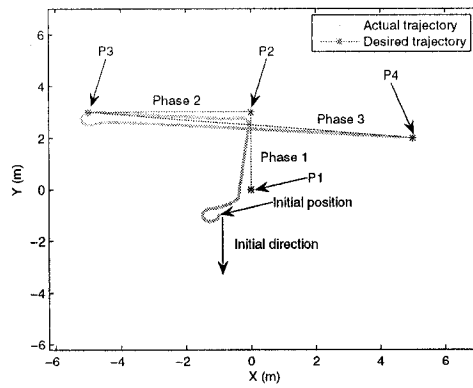

(a)

Distance between  
robot and P1

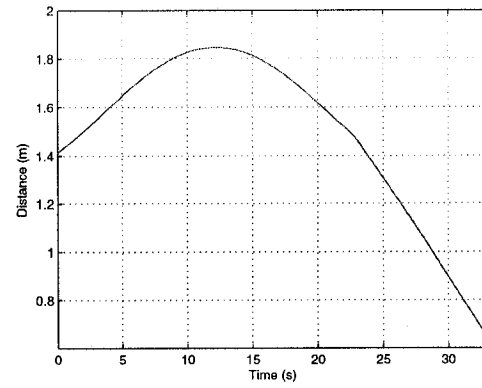

(b)

Tracking error

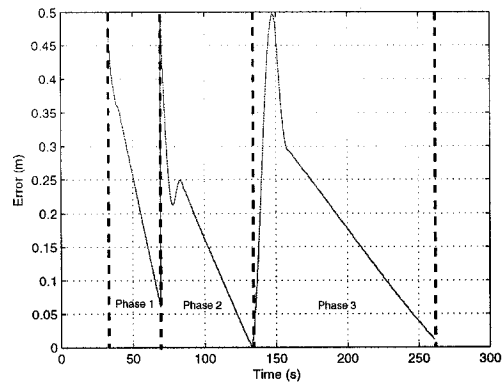

(c)

Tag Received Power (TRP)

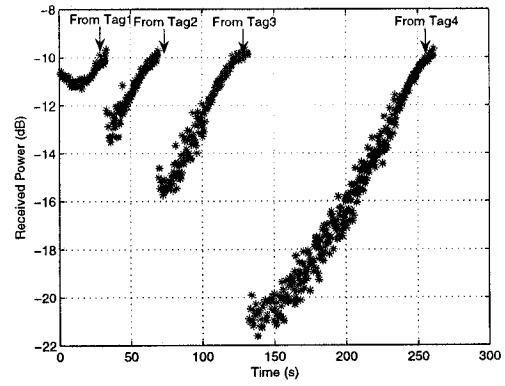

(d)

Figure 5.12: Performance of the proposed navigation algorithm on a three-segment trajectory.

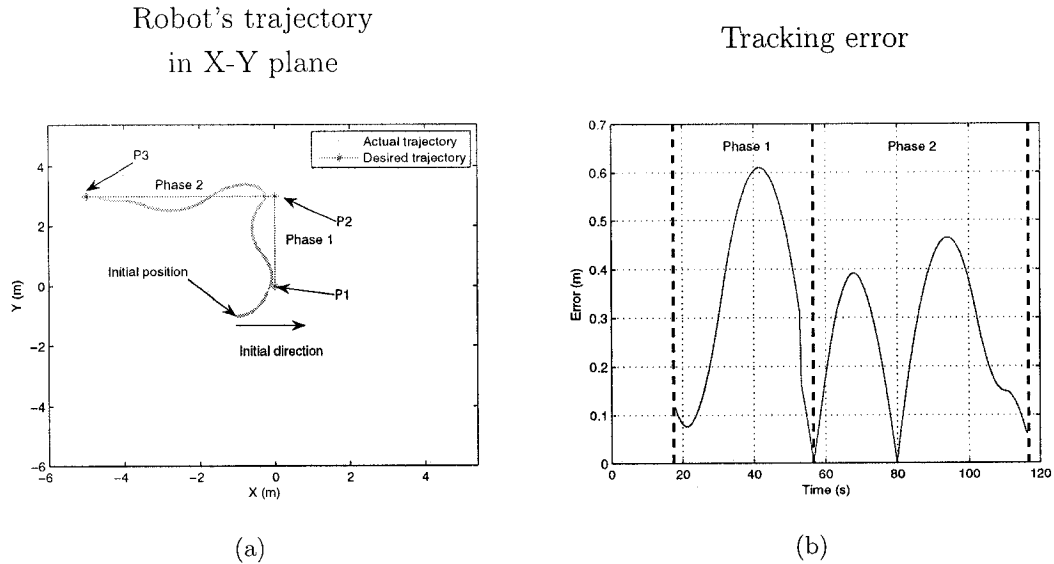

Figure 5.13: Performance of the proposed navigation algorithm using a proportional controller (considering RF noise). (a) The trajectory of the mobile robot in the X-Y plane and (b) the tracking error (distance between the robot's instantaneous position and the desired path).

Figure 5.14 shows the robot's performance in the second experiment. First, the robot is trying to reach P1, but it dramatically diverges from its desired path. After about 50 seconds, it realizes that it should converge and then moves towards P2. So the tracking error is surprisingly decreasing in this phase which is shown in Figure 5.14(b). We note plenty of fluctuations as shown at the second phase of Figure 5.14(b). As the time passes, the robot keeps diverging further away from the target navigation line which is shown at the third phase of navigation (see Figure 5.14(a)).

Comparing both types of controllers, the superior performance of the FLC is quite clear.

## 5.6 Discussion

In this chapter, we have presented a novel mobile robot navigation technique using a customized RFID tag architecture in co-operation with fuzzy logic controller. The transponder ID is combined with the received power (TRP) of the signal sent by the reader of the RFID system. This combined ID and TRP is then backscattered to the reader as a

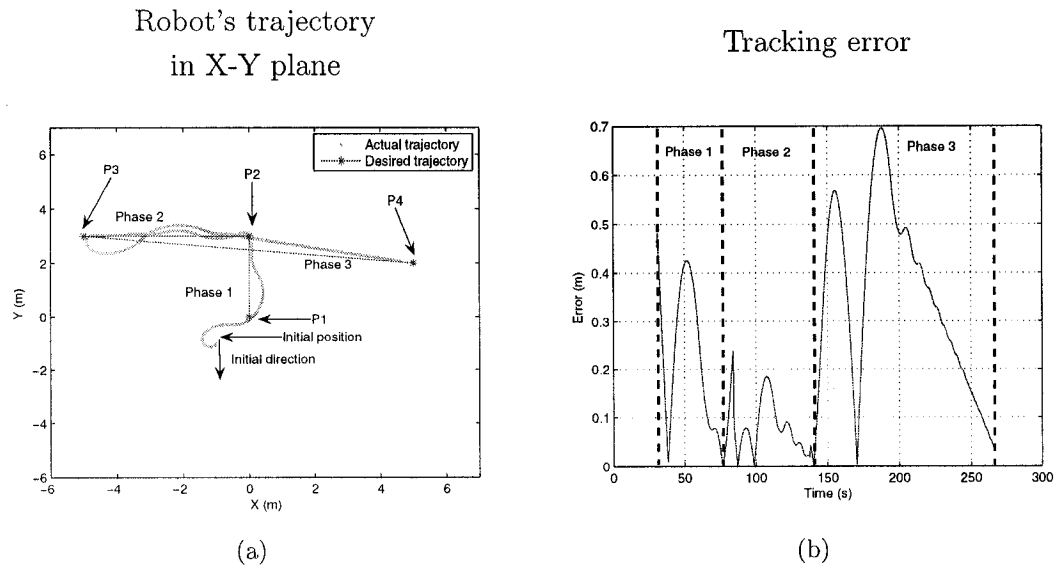

Figure 5.14: Performance of the proposed navigation algorithm using a proportional controller (considering RF noise). (a) The trajectory of the mobile robot in the X-Y plane and (b) the tracking error (distance between the robot's instantaneous position and the desired path).

frame. The robot extracts the TRP(s) from the frame in order to compute the line-of-sight distance(s) between the robot and transponder(s). At least three transponders are required to compute the robot's position at every time instant. The angle between the robot's current position and the current target is calculated and fed to the FLC in order to provide necessary control actions to its actuators to reach all target points in the path. This algorithm is tested with and without noise in the environment while receiving the power of the signal sent by the reader (TRP). The proposed algorithm is also examined with and without using fuzzy logic controller in order to justify the use of the FLC. The experimental results illustrate that the FLC provides smoother navigation trajectories and smaller trajectory errors.

# Chapter 6

## Conclusion and Future Work

### 6.1 Conclusion

In this thesis, we have described two novel solutions to the mobile robot navigation problem based on minor customizations of current commercial RFID systems. Based on the previous description and results, we can draw several conclusions after weighing the pros and cons of the proposed algorithms for mobile robot navigation.

In the first algorithm which is presented in Chapter 4, the robot is equipped with an RFID reader where the custom-made reader has two receiving antennas, and the RFID tags are attached on the ceiling of the environment. The two antennas of the reader on the robot provide the phase difference of the signal sent by the tag. The robot is able to reach any specified RFID tag location by simple intelligent processing of this phase difference. It has been shown through six different experiments that neither the initial position nor the initial direction of the robot affects the algorithm's performance in reaching its target, as long as the reader remains within an access range from its target transponder. In addition to that, the algorithm offers excellent performance in tracking rectilinear trajectories defined by several transponders placed at unknown locations in the 3-dimensional space. The locations of the tags in the world coordinate system are irrelevant for this navigation algorithm since the desired trajectory is given with respect to the tags.

We introduced another algorithm in Chapter 5 that is based on the robot's absolute position. Determining the instantaneous position of the robot is based on the signal received from at least three tags at a time. In this case, the tag circuitry is customized where the tag ID is combined with the received power sent by the reader in order to make

a frame. The frame is sent back to the reader from which the robot can extract the power to determine its current position. From this position information, the robot can calculate the angle between its current and desired direction. This angle is used as a navigation parameter in reaching the predefined target points listed in the robot's memory. On top of that, the algorithm is able to provide a certain degree of fault tolerance. In case any of the tags fails, the robot can still navigate using the information received from other tags within its communication range if there are at least three of them. A fuzzy logic controller is incorporated for both of the aforementioned algorithms to provide control actions to the robot. The fuzzy logic controller proved its superiority to a conventional proportional controller in leading to a smaller tracking error and faster convergence. It was more intuitive to use a fuzzy logic controller in such an application thanks to its ability in incorporating human expertise and behaviors, which are well developed in these type of problems.

We found through simulation that overall, both algorithms can successfully drive the mobile robot from one place to another in an indoor environment. Roughly stated, between the two new algorithms, the first algorithm yields better performance in terms of computational complexity, simplicity, and accuracy. This algorithm is suitable when the antennas of the reader provide precise signals about the tag. All that this algorithm does is to track the sign of the phase difference to navigate the robot along a desired trajectory. However, it is possible for the reader not to accurately provide the sign of the phase difference of the received signal. On the other hand, the second algorithm can be applicable in a specific indoor application where instantaneous position information is necessary. This algorithm relies on trilateration to estimate the robot's position. Nevertheless, imprecise measurements of the signal received power and distances are among the main challenges facing this algorithm.

In summary, we proposed navigation schemes which allow mobile robots to operate reliably and efficiently in a priori unknown environment and thus realize an important step towards truly autonomous mobile robots. The proposed algorithms do not rely on any sensors other than the RFID reader and tags. This is unlike many algorithms of similar nature presented in the literature where the robot needs a fair number of sensors of various types, shapes and sizes for it to navigate. In addition, both navigation algorithms presented herein do not require building an approximate map of the robot's workspace. As a matter of fact, both algorithms are free of any complex computational processes.

This study opens the doors for a new class of robot navigation techniques that are

simple, computationally- and cost-effective, and modular, in the sense that they are independent of any specific robot architecture. Having said that, it is important to articulate the fact that this technique is not meant to substitute vision-based navigation algorithms. Rather, it might be regarded as an alternative navigation solution for many robotic applications where vision systems might not be necessary.

## 6.2 Future Work

Although the suggested algorithms stated in this dissertation were only applied to navigate mobile robots in an indoor environment, they can be easily extended to outdoor mobile robots and unmanned vehicles as well. The next stage will be to physically implement both algorithms on a real mobile robot. Another potential future research avenue to extend this work is to append the algorithm with a real-time path planning module by knowing the RFID tag locations in advance in the 3-dimensional space. In addition to that, the robot can be mounted with several range sensors to incorporate some obstacle avoidance strategies.

## References

- [1] Yasunori Abe, Masaru Shikano, Toshio Fukuda, Fumihito Arai, and Yoshio Tanaka. Vision based navigation system for autonomous mobile robot with global matching. In *IEEE International Conference on Robotics and Automation*, volume 2, pages 1299–1304, 1999.
- [2] Amit Adam, Ehud Rivlin, and Hector Rotstein. Fusion of fixation and odometry for vehicle navigation. *IEEE Transactions on Systems, Man, and Cybernetics Part A: Systems and Humans*, 29(6):593–603, November 1999.
- [3] Bruno Apolloni and Adrian Moise. Mobile robot navigation using the mathematical model of the sensing system. In *Proceedings of the IEEE International Conference on Systems, Man and Cybernetics*, volume 4, pages 2625–2630, 2000.
- [4] Stephane Betge-Brezetz, Raja Chatila, and Michel Devy. Natural scene understanding for mobile robot navigation. In *IEEE International Conference on Robotics and Automation*, pages 730–736, 1994.
- [5] J. Borenstein, H. R. Everett, L. Feng, and D. Wehe. Mobile robot positioning: Sensors and techniques. *Journal of Robotic Systems*, 14(4):231–249, April 1997.
- [6] Zhichao Chen and Stanley T. Birchfield. Qualitative vision-based mobile robot navigation. In *IEEE International Conference on Robotics and Automation*, 2006.
- [7] Frank Dellaert, Dieter Fox, Wolfram Burgard, and Sebastian Thrun. Monte carlo localization formobile robots. In *IEEE International Conference on Robotics and Automation*, 1999.
- [8] Guilherme N. DeSouza and Avinash C. Kak. Vision for mobile robot navigation: A survey. *IEEE Transactions on Pattern Analysis and Machine Intelligence*, 24(2):237–267, February 2002.

- [9] T. D'Orazio, M. Ianigro, E. Stella, F. P. Lovergine, and A. Distanto. Mobile robot navigation by multi-sensory integration. In *IEEE International Conference on Robotics and Automation*, volume 2, pages 373–379, 1993.
- [10] K. C. Drake, E. S. McVey, and R. M. Inigo. Sensor roll angle error for a mobile robot using a navigation line. *IEEE Transactions on Pattern Analysis and Machine Intelligence*, 10(5):727–731, September 1988.
- [11] Klaus Finkenzeller. *RFID Handbook: Fundamentals and Applications in Contactless Smart Cards and Identification*. Wiley, 2 edition, May 2003.
- [12] Dieter Fox, Wolfram Burgard, Frank Dellaert, and Sebastian Thrun. Monte carlo localization: Efficient position estimation for mobile robots. In *Proceedings of the National Conference on Artificial Intelligence*, pages 343–349, 1999.
- [13] Chaitanya Gharpure, Vladimir Kulyukin, and Aliasgar Kutiyawala. A robotic shopping assistant for the blind: A pilot study in a supermarket. Technical report usu-csat1-1-01-06, Utah State University, Computer Science Assistive Technology Laboratory, Department of Computer Science, Utah State University, January 2006.
- [14] Wail Gueaieb and Md. Suruz Miah. Experiments on a novel modular cost-effective RFID-based mobile robot navigation system. In *Proceedings of the IEEE International Conference on Systems, Man, and Cybernetics*, Montreal, Canada, October 7–10 2007. (In press).
- [15] Wail Gueaieb and Md. Suruz Miah. An intelligent mobile robot navigation technique using RFID technology. *IEEE Transactions on Instrumentation and Measurement*, 2007. (Accepted to appear).
- [16] Ireneusz Hallmann and Barbara Siemiatkowska. Artificial landmark navigation system. In *International Symposium on Intelligent Robotic Systems*, July 2001.
- [17] Yifeng Han, Qiang Li, and Hao Min. System modeling and simulation of RFID, 2004.
- [18] Bo He, Danwei Wang, Minhtuan Pham, and Tieniu Yu. Gps/encoder based precise navigation for a 4ws mobile robot. In *7th International Conference on Control, Automation, Robotics and Vision*, Singapore, December 2002.

- [19] Martial Hebert and Takeo Kanade. 3-d vision for outdoor navigation by an autonomous vehicle. In *Proceedings of the 1988 DARPA Image Understanding Workshop*, pages 593–601, April 1988.
- [20] Chae Heesung and Han Kyuseo. Combination of rfid and vision for mobile robot localization. In *Proceedings of the 2005 Intelligent Sensors, Sensor Networks and Information Processing Conference*, volume 2005, 2005.
- [21] Huosheng Hu and Dongbing Gu. Landmark-based navigation of mobile robots in manufacturing. In *IEEE International Conference on Emerging Technologies and Factory Automation*, Barcelona, Spain, October 1999.
- [22] B. Everett J. Borenstein and L. Feng. *Navigating Mobile Robots: Systems and Techniques*. Wellesley, 1996.
- [23] Fakhreddine Karray and Clarence W. de Silva. *Soft Computing and Intelligent Systems Design, Theory, Tools and Applications*. Addison-Wesley, Pearson Education Limited, Essex, England, 2004.
- [24] Vedran Kordic, Aleksandar Lazinica, and Munir Merdan. *Cutting Edge Robotics*. pro literatur Verlag, 2005.
- [25] S. Kotani, K. Kaneko, T. Shinoda, and H. Mori. Mobile robot navigation based on vision and dgps information. In *IEEE International Conference on Robotics and Automation*, volume 3, pages 2524–2529, 1998.
- [26] Olaf Kubitz, Matthias O. Berger, Marcus Perlick, and Rene Dumoulin. Application of radio frequency identification devices to support navigation of autonomous mobile robots. In *IEEE Vehicular Technology Conference*, pages 126–130, 1997.
- [27] Michail G. Lagoudakis and Anthony S. Maida. Neural maps for mobile robot navigation. In *Proceedings of the International Joint Conference on Neural Networks*, volume 3, pages 2011–2016, 1999.
- [28] Tsong-Li Lee, Li-Chun Lai, and Chia-Ju Wu. A fuzzy algorithm for navigation of mobile robots in unknown environments. In *IEEE International Symposium on Circuits and Systems*, volume 4, pages 3039– 3042, May 2005.

- [29] M.Ni Lionel, Yunhao Liu, Yiu Cho Lau, and Abhishek P. Patil. LANDMARC: Indoor location sensing using active RFID. *Wireless Networks*, 10(6):701–710, November 2004.
- [30] Hannu Makela and Kari Koskinen. Navigation of outdoor mobile robots using dead reckoning and visually detected landmarks. In *Fifth International Conference on Advanced Robotics*, page 1051, 1991.
- [31] E. S. McVey, K. C. Drake, and R. M. Inigo. Range measurements by a mobile robot using a navigation line. *IEEE Transactions on Pattern Analysis and Machine Intelligence*, 8(1):105–109, January 1986.
- [32] Qinghao Meng and Rainer Bischoff. Odometry based pose determination and errors measurement for a mobile robot with two steerable drive wheels. *Journal of Intelligent and Robotic Systems archive*, 41(4):263–282, January 2005.
- [33] Md. Suruz Miah and Wail Gueaieb. Intelligent parallel parking of a car-like mobile robot using RFID technology. In *IEEE International Workshop on RObotic and Sensors Environments*, Ottawa, Canada, October 12–13 2007. (Accepted to appear).
- [34] Md. Suruz Miah and Wail Gueaieb. An RFID-based robot navigation system with a customized RFID tag architecture. In *Proceedings of the IEEE International Conference on Microelectronics*, Cairo, Egypt, December 29–31 2007. (Accepted to appear).
- [35] Md. Suruz Miah, Wail Gueaieb, Md. Abdur Rahman, and Abdulmotaleb El Sadik. Autonomous dead-reckoning mobile robot navigation system with intelligent precision calibration. In *Proceedings of the IEEE Instrumentation and Measurement Technology Conference (IMTC2007)*, Warsaw, Poland, May 1–3 2007.
- [36] Don Murray and James J. Little. Using real-time stereo vision for mobile robot navigation. *Autonomous Robots*, 8(2):161–171, April 2000.
- [37] Kazunori Ohno, Takashi Tsubouchit, Bunji Shigematsut, Shoichi Maeyamas, and Shin'ichi Yuta. Outdoor navigation of a mobile robot between buildings based on DGPS and odometry data fusion. In *IEEE International Conference on Robotics and Automation. ICRA '03.*, volume 2, pages 1978–1984, September 2003.

- [38] A. Ohya, A. Kosaka, and A. Kak. Vision-based navigation by a mobile robot with obstacle avoidance using single-camera vision and ultrasonic sensing. *IEEE Transactions on Robotics and Automation*, 14(6):969–978, December 1998.
- [39] Lauro Ojeda, Daniel Cruz, Giulio Reina, and Johann Borenstein. Current-based slippage detection and odometry correction for mobile robots and planetary rovers. *IEEE Transactions on Robotics*, 22(2):366–378, April 2006.
- [40] Dayal R. Parhi. Navigation of mobile robots using a fuzzy logic controller. *Journal of Intelligent and Robotic Systems: Theory and Applications*, 42(3):253–273, March 2005.
- [41] KyuCheol Park, Dohyoung Chung, Hakyoung Chung, and Jang Gyu Lee. Dead reckoning navigation of a mobile robot using an indirect kalman filter. In *IEEE International Conference on Multisensor Fusion and Integration for Intelligent Systems*, pages 132–138, 1996.
- [42] KyuCheol Park, Hakyoung Chung, Jongbin Choi, and Jang Gyu Lee. Dead reckoning navigation for an autonomous mobile robot using a differential encoder and a gyroscope. In *8th International Conference on Advanced Robotics, ICAR '97*, pages 441–446, July 1997.
- [43] Liliane Peters, Michael Pauly, and Klaus Beck. Servicebots mobile robots in cooperative environments. In *ERCIM News*, number 42, July 2000.
- [44] James Lyle Peterson. *Petri Net Theory and the Modeling of Systems*. Prentice Hall, N.J. Englewood Cliff, 1981.
- [45] D.T. Pham and Dayal R. Parhi. Navigation of multiple mobile robots using a neural networks and a petri net model. *Robotica*, 21(1):79–93, January/February 2003.
- [46] Md. Abdur Rahman, Md. Suruz Miah, Wail Gueaieb, and Abdulmotaleb El Saddik. A framework for sensory-based P2P collaborative environment. In *Proceedings of the IEEE Instrumentation and Measurement Technology Conference (IMTC2007)*, Warsaw, Poland, May 1–3 2007.
- [47] Md. Abdur Rahman, Md. Suruz Miah, Wail Gueaieb, and Abdulmotaleb El Saddik. A P2P sensor framework for collaborative robots manipulation. In *Proceedings of the Second International Conference on Systems (ICONS 2007)*, Martinique, French Caribbean, April 22–28 2007.

- [48] Md. Abdur Rahman, Md. Suruz Miah, Wail Gueaieb, and Abdulmotaleb El Saddik. SENORA: A P2P service oriented framework for collaborative multi-robot sensor network. *IEEE Sensors Journal, Special Issue on Intelligent Sensors*, 7(5):658–666, May 2007.
- [49] Petru Rusu, Emil M. Petriu, Thom E. Whalen, Aurel Cornell, and Hans J.W. Spoelder. Behavior-based neuro-fuzzy controller for mobile robot navigation. *IEEE Transactions on Instrumentation and Measurement*, 52(4):1335–1340, August 2003.
- [50] Alessandro Saffiotti. The uses of fuzzy logic for autonomous robot navigation: a catalogue raisonné. *Soft Computing Research journal*, 1(4):180–197, 1997.
- [51] Reza Shahidi, Mark Shayman, and P. S. Krishnaprasad. Mobile robot navigation using potential functions. In *Proceedings - IEEE International Conference on Robotics and Automation*, volume 3, pages 2047–2053, 1991.
- [52] William Stallings. *Data and Computer Communications*. Prentice Hall, 8 edition, 2006.
- [53] E. Stella, F.P. Lovergine, L. Caponetti, and A. Distanto. Mobile robot navigation using vision and odometry. In *Proceedings of the Intelligent Vehicles '94 Symposium*, pages 417–422, October 1994.
- [54] Chuck Thorpe, Martial Hebert, Takeo Kanade, and Steven Shafer. Vision and navigation for the carnegie-mellon navlab. *IEEE Transactions on Pattern Analysis and Machine Intelligence*, 10(3):362–373, 1988.
- [55] Sebastian Thrun. Finding landmarks for mobile robot navigation. In *IEEE International Conference on Robotics and Automation*, volume 2, pages 958–963, 1998.
- [56] Sebastian Thrun, Wolfram Burgard, and Dieter Fox. A probabilistic approach to concurrent mapping and localization for mobile robots. *Machine Learning*, 31(1-3):29–53, 1998.
- [57] Sebastian Thrun, Wolfram Burgard, and Dieter Fox. *Probabilistic Robotics*. MIT Press, 2005.
- [58] Toshifumi Tsukiyama. Global navigation system with RFID tags. In *Proceedings of SPIE - The International Society for Optical Engineering*, volume 4573, pages 256–264, 2001.

- [59] Toshifumi Tsukiyama. World map based on rfid tags for indoor mobile robots. In *Proceedings of SPIE - The International Society for Optical Engineering*, volume 6006, 2005.
- [60] Sada Wane and Cina Motamed. Navigation system for a mobile robot in an unstructured environment. In *Proceedings of the IEEE International Conference on Systems, Man and Cybernetics*, volume 3, pages 2797–2802, 1994.
- [61] O. Wijk and H.I. Christensen. Localization and navigation of a mobile robot using natural point landmarks extracted from sonar data. *Robotics and Autonomous System*, 31(1-2):31–42, April 2000.
- [62] Soo-Yeong Yi and Byoung-Wook Choi. Autonomous navigation of indoor mobile robots using a global ultrasonic system. *Robotica archive*, 22(4):369–374, August 2004.