



National Library
of Canada

Bibliothèque nationale
du Canada

Canadian Theses Service Service des thèses canadiennes

Ottawa, Canada
K1A 0N4

NOTICE

The quality of this microform is heavily dependent upon the quality of the original thesis submitted for microfilming. Every effort has been made to ensure the highest quality of reproduction possible.

If pages are missing, contact the university which granted the degree.

Some pages may have indistinct print especially if the original pages were typed with a poor typewriter ribbon or if the university sent us an inferior photocopy.

Reproduction in full or in part of this microform is governed by the Canadian Copyright Act, R.S.C. 1970, c. C-30, and subsequent amendments.

AVIS

La qualité de cette microforme dépend grandement de la qualité de la thèse soumise au microfilmage. Nous avons tout fait pour assurer une qualité supérieure de reproduction.

S'il manque des pages, veuillez communiquer avec l'université qui a conféré le grade.

La qualité d'impression de certaines pages peut laisser à désirer, surtout si les pages originales ont été dactylographiées à l'aide d'un ruban usé ou si l'université nous a fait parvenir une photocopie de qualité inférieure.

La reproduction, même partielle, de cette microforme est soumise à la Loi canadienne sur le droit d'auteur, SRC 1970, c. C-30, et ses amendements subséquents.

**A Comparison of Peak Blood Lactates Following Maximal
Upper Body and Maximal Combined Upper and Lower Body
Simulated Ski Exercises in Elite Cross-Country Skiers**

Kimberly C. Mansfield

University of Ottawa, Department of Kinanthropology

**Thesis submitted to the School of Graduate Studies and Research
in partial fulfillment of the requirements for the M.Sc. degree in
Kinanthropology**



Kimberly C. Mansfield, Ottawa, Canada, 1989



National Library
of Canada

Bibliothèque nationale
du Canada

Canadian Theses Service Service des thèses canadiennes

Ottawa, Canada
K1A 0N4

The author has granted an irrevocable non-exclusive licence allowing the National Library of Canada to reproduce, loan, distribute or sell copies of his/her thesis by any means and in any form or format, making this thesis available to interested persons.

The author retains ownership of the copyright in his/her thesis. Neither the thesis nor substantial extracts from it may be printed or otherwise reproduced without his/her permission.

L'auteur a accordé une licence irrévocable et non exclusive permettant à la Bibliothèque nationale du Canada de reproduire, prêter, distribuer ou vendre des copies de sa thèse de quelque manière et sous quelque forme que ce soit pour mettre des exemplaires de cette thèse à la disposition des personnes intéressées.

L'auteur conserve la propriété du droit d'auteur qui protège sa thèse. Ni la thèse ni des extraits substantiels de celle-ci ne doivent être imprimés ou autrement reproduits sans son autorisation.

ISBN 0-315-60009-8

Canada



UNIVERSITÉ D'OTTAWA
UNIVERSITY OF OTTAWA

DEDICATION

To my father Arthur George Reid, a very special man who taught me
to make the most of my dreams.

ACKNOWLEDGEMENTS

Many thanks to Dr. Al Reed for his guidance and editing ability, and to Dr. J.S.Thoden for his support and encouragement.

To those who graduated before me, Glenn, Pearl, Rick, Pete and Rob, thanks for the inspiration.

To my friends, Ryan, Martine, Dave, Suzanne, Brenda, Luce, Susan, the McLeans, the Belbecks and the Bakers, thanks for being there.

To my family, Mom, Sue, Tob, Amy, Glenn, Mike, all the Cobbs, and all the Mansfields, thanks for seeing me through to the end.

Most importantly, thank-you Kevin for your tolerance, patience, unending support and your faith in my ability. We did it!

Table of Contents

Chapter 1 - The Problem	Page
1.1 Introduction	1
1.2 Rationale	5
1.3 Purpose	6
1.4 Limitations of Study	6
1.5 Abbreviations	8
1.6 Definitions	10
Chapter 2 - Review of Literature	
2.1 Introduction	11
2.2 Skeletal Muscle Fibre Types	11
2.3 Lactic Acid Production Removal and Turnover During Exercise	24
2.4 Upper Body and Lower Body Exercise and Lactate Responses	38
2.5 Lactate Response in Combined Arm Plus Leg Exercise	53
Chapter 3 - Methodology	
3.1 Introduction	63
3.2 Subjects	63
3.3 Protocol	65
3.4 Statistical Analysis	70
Chapter 4 - Results	
4.1 Introduction	73
4.2 Discussion	79
Chapter 5 - Conclusions and Recommendations	
5.1 Introduction	94
5.2 Conclusions	94
5.3 Recommendations	96

Table of Contents - Continued

	Page
Bibliography	98
Appendices	
Appendix A : Phase One Ski Treadmill	113
Appendix B : Phase Two Ski Treadmill	114
Appendix C : Rollerboard Plan	115
Appendix D : Raw Subject Data Table	116

List of Tables

	Page
1. Functional Properties of SO and FG Fibers in Human Skeletal Muscle	13
2. Mean, Standard Deviation and Range of MVO_2 Values Grouped According to Team Membership	64
3. Phase One and Phase Two Mean MVO_2 , TTT, PBLa(A), PBLa(A+L), and LI Values	74
4. Mean MVO_2 and TTT Values From Two Different A+L Protocols on Male and Female Subjects	74
5. Correlational Matrix Presenting the Correlation Coefficients for LI, PBLa(A), PBLa(A+L), MVO_2 , and TTT Taken as Pairs	77
6. MVO_2 as a Function of A+L Protocol and Gender	79
7. PBLa as a Function of Mode of Exercise	82
8. Tukey's Studentized Range Honestly Significant Difference (HSD) Test for the Variable : Peak Blood Lactate	82

Abstract

Peak fingertip blood lactate values obtained following maximal intensity simulated double poling ski exercise (PBLa(A)), were compared with peak fingertip blood lactate values obtained following maximal intensity simulated combined arm and leg ski striding exercise (PBLa(A+L)). The combined arm and leg protocols were performed on two different types of treadmills, a walking treadmill and a ski treadmill. Subjects included 8 male and 5 female highly endurance trained (54.3-78.5 ml kg min) Canadian National Senior and Junior Cross Country Ski Team members. Data was collected in two phases from two successive May/June testing sessions over a one year span. Phase one combined arms and legs ski striding protocol (A+L)₁, involved ski walking on a treadmill with simultaneous arm poling movements achieved through a rope pulley system. Treadmill incline and pulley resistance were increased every 2 minutes until maximal oxygen consumption (MVO₂) was achieved. Phase two combined arms and legs ski striding protocol (A+L)₂, represented a more sports specific exercise whereby skiers using skis and poles performed a diagonal stride on a carpeted treadmill. Here, speed and /or grade changed every 3 minutes until a point of volitional fatigue (which usually coincided with a plateau of oxygen consumption) was achieved. In both (A+L) protocols, expired gases were collected using a tissot tank and analyzed at 30

second intervals with a Roxelon Medi-Tech Oxygen and Carbon Dioxide Analyzer. $\dot{M}V\dot{O}_2$ (ml kg min) and total test time (TTT) in minutes was recorded for each A+L protocol. Heart rates were recorded using a Polar Electro PE3000 Sport Tester Heart Rate Monitor from the beginning of exercise until achievement of a heart rate of 120 beats per minute post exercise. Fingertip blood samples were drawn at the end of each treadmill stage and 0-3 minutes post exercise for lactate analysis. The arms only double poling exercise protocol (A), was conducted identically in both test phases. Kneeling on a trolley or rollerboard, skiers pulled themselves up a 95 inch inclined track using rope pulleys at a cadence of one pull every 2.5 seconds. Test duration was 2 minutes. Fingertip blood samples were drawn at 2 and 3 minutes post exercise for blood lactate analysis. Blood lactate analysis was conducted using the Kontron 640 Lactate Analyzer. Peak blood lactate values represented the highest blood lactate value obtained from the post exercise samples collected under the three exercise conditions, PBLa(A), PBLa(A+L)₁ and PBLa(A+L)₂. Lactate Index (LI), represented by PBLa(A) divided by PBLa(A+L), was derived for all subjects in both test phases. LI was selected to reflect the influence of team designation and A+L protocol on individual PBLa(A) relative to PBLa(A+L) exercise responses. In both test phases, PBLa(A) values were higher than PBLa(A+L) values. Significant differences ($p < 0.05$) were found between PBLa(A) and PBLa(A+L)₁ but not between

PBLa(A) and PBLa(A+L)₂. (A+L)₁ elicited significantly ($p < 0.05$) higher MVO₂ values than (A+L)₂ while PBLa(A+L)₁ were significantly lower ($p < 0.05$) than PBLa(A+L)₂ values. No statistically significant correlation was found between PBLa(A), PBLa(A+L), and MVO₂ values. No statistically significant correlation was found between PBLa(A), PBLa(A+L) and TTT values. It was suggested that the lower PBLa(A+L) values relative to the PBLa(A) values could be a function of the addition of active lower body muscle mass to upper body exercise. The lactate oxidizing capacity of the lower limb slow oxidative fibre inherent in the skiers' endurance trained lower body served to lower PBLa(A+L) below PBLa(A). Differences in phase one and two PBLa(A+L) and MVO₂ values were related to the degree of sports specificity of the A+L protocol to cross-country skiing. It was suggested that (A+L)₂ represented a more sports specific and familiar movement pattern. This enabled skiers to involve a greater porportion of muscle mass and achieve higher blood lactate levels through increased recruitment of fast glycolytic fibre. Finally it was suggested that the lack of statistically significant correlations between PBLa(A), PBLa(A+L), MVO₂, TTT, and LI indicated these variables were truely independent of one another and represented distinct physiological responses.

CHAPTER I

The Problem

1.1 Introduction

The purpose of this chapter is to highlight the conception, rationale and purpose of this study, review the limitations and finally, list the abbreviations and definitions that will be used in the successive chapters.

The performance of endurance athletes has inspired investigation of numerous physiological indices, i.e. relative body fat, maximal oxygen consumption and the percentage of slow twitch muscle fibre. One area of particular interest is lactic acid production, accumulation and removal. Summarized by Hultman and Sahlin in a 1981 review, elevated levels of muscle lactate accelerate creatine phosphate breakdown and inhibit glycolysis. The associated decline in muscle pH interferes with the calcium triggering of muscle contraction leading to systemic inhibition of lipolysis and acceleration of carbohydrate utilization. Ultimately muscle glycogen, the key substrate supporting an endurance exercise performance, is utilized at a faster rate and subsequently depleted at an earlier point in time, thus accelerating fatigue. Minimizing lactic acid accumulation

during performance then is of primary importance to the endurance athlete.

Blood lactate concentration (BLa) represents the net result between the rate of entry of lactate into the blood and the rate of disappearance from the blood. In light of this, the metabolic importance of slow oxidative (SO) and fast glycolytic (FG) skeletal muscle fibre becomes apparent. Since SO fibre participates in lactate removal and FG fibre participates in lactate production, an intimate relationship between fibre type and BLa must exist.

An endurance performance may incorporate both simple and complex movements i.e., arms only (A), legs only (L), or combined arms and legs (A+L). While fibre type complement would undoubtedly influence BLa in these exercise situations, the influence of fibre type distribution between upper and lower body on BLa would also warrant close consideration.

It is well accepted that at a given relative or absolute submaximal load, A exercise is performed at a greater physiological cost than L and A+L exercise. Studies of untrained (UT) individuals have demonstrated higher lactate production in relation to oxygen uptake during A exercise performances as compared to L and A+L exercise, L lactate values being greater than or equal to that produced during

A+L exercise (Bevegard, Freyschuss, & Strandell, 1966; Freyschuss and Strandell, 1967).

Studies of trained (T) cross-country skiers at submaximal workloads (Millerhagen, 1983) revealed significant delays in attainment of ventilatory anaerobic threshold with respect to time and work rate, during A+L simulated ski exercise. Similarly at maximal loads, sustained treadmill incline and mean endurance time were greater in A+L exercise while perceived exertion was less when compared to the L and A exercise conditions.

During A+L exercise, one might expect the additive effects of upper and lower body muscle mass to produce lactate values that surpass those attained during A or L exercise. Research at maximal exercise conditions however reveals that A+L lactate is always less than or equal to that achieved in L exercise (Astrand & Saltin, 1961; Bergh, Kanstrup & Ekblom, 1976; Secher, Ruberg-Larsen, Binkhorst, & Bonde-Petersen, 1974; Vokac, Bell, Bantz-Holter, & Rodahl, 1975). In all instances lactate during A exercise is less than that achieved during L and A+L exercise under maximal exercise conditions.

Interestingly enough, pilot data collected at the University of Ottawa contradict the aforementioned observations (Reed & Thoden, 1984). Peak lactates obtained

after maximal A exercise tests were significantly higher than those obtained after A+L maximal oxygen consumption (MVO_2) tests on elite cross-country skiers. These findings have been consistent over a two year testing cycle.

Although no researchers to date have reported similar observations, findings of Freyschuss and Strandell (1967) point to one possible explanation. Performance of A and L exercise at submaximal loads revealed that lactic acid values in venous blood of non-exercising limbs were lower than those in arterial blood indicating net removal of lactate by non-exercising extremities. Freyschuss and Strandell (1967) suggested that legs were more effective eliminators than arms removing 40% of lactate produced by arms versus 30% removed by arms during leg work.

It is possible then that the addition of leg work to arm work with its large mass and potentially high oxidization capability could lower A+L exercise lactate values beyond that seen in L and A exercise. Thus, the relationship of fibre type metabolism as indicated by BLa levels, to upper and lower body endurance training, and sports specific exercise, is one area of research worthy of further investigation.

1.2. Rationale

To characterize lactate differences between A and A+L exercise, peak lactate values obtained after maximal A and A+L exercise were selected for comparison. Maximal exercise conditions were selected to challenge the lactate production and removal ability of FG and SO fibre respectively.

Since their upper and lower body endurance training and high aerobic fitness would maximize the effects of uptake mechanisms on lactic acid levels, subjects selected were members of the Canadian Junior and Senior National Cross-Country Ski Team.

To ensure that exercise bouts were maximal and reflective of the muscle mass used in the training for, and actual performance of cross-country skiing, exercise protocols were performed on training devices which were familiar to skiers and incorporated familiar ski movement patterns.

In this way relationships between high aerobic fitness, sports specific training of muscle mass, lactate production and removal, and endurance capacity could be identified and insight into the physiology of A+L exercise obtained.

1.3 Purpose

If moderately high to high endurance trained cross-country skiers (54.3-78.5 ml/kg/min) may be characterized by good lactate removal, then peak lactates obtained after an A maximal exercise will be higher than those obtained after a maximal A+L exercise. The purpose of this study then is to verify the above hypothesis by comparing peak fingertip lactate values obtained following maximal intensity simulated double poling exercise A and A+L ski striding exercise performed on two different types of treadmills. Of secondary interest is the identification of relationships existing between whole blood lactate, aerobic fitness indicators and endurance capacity .

1.4 Limitations of Study

As the A double-poling and the A+L ski striding exercise simulations are highly sports specific, generalizations about other sports incorporating A and A+L exercise will be limited. Similarly, comparisons of results with those obtained through studies observing different forms of A and A+L exercise (i.e., arm cranking and cycling) must be made with caution. Finally it is important to recognise that all exercise simulations have limitations and may never identically mimic a sports performance.

With respect to the nature and number of subjects selected for the study, it must be understood that the generalizability of results will be specific to high aerobically trained cross-country skiers only.

Fingertip sampling for lactic acid will prevent analysis of site specific arterial and venous lactate differences and comparisons of intramuscular and blood lactate values, and analysis of only peak lactic acid values will not allow for investigation of the underlying mechanisms responsible for lactate levels in the blood.

1.5 Abbreviations

A	:	Arms only
A+L	:	Arms and Legs
AT	:	Anaerobic Threshold
ATP	:	Adenosine Triphosphate
ADP	:	Adenosine Diphosphate
BLa	:	Blood Lactate Concentration
CP	:	Creatine Phosphate
CPK	:	Creatine Phosphokinase (2.7.3.2)
FG	:	Fast Glycolytic / Fast Twitch Fibre
FOG	:	Fast Oxidative Glycolytic Fibre
La	:	Lactic Acid
LaT	:	Lactate Threshold
L	:	Legs Only
LI	:	Lactate Index
LDH	:	Lactate Dehydrogenase (1.1.1.27)
LDH-H	:	Lactate Dehydrogenase- Heart Isozyme Form
LDH-M	:	Lactate Dehydrogenase- Muscle Isozyme Form
MLa	:	Muscle Lactate
MK	:	Myokinase (2.7.4.3.)
MVC	:	Maximal Voluntary Contraction
MVO ₂	:	Maximal Oxygen Consumption
NAD ⁺	:	Nicotinamide Adenine Dinucleotide

Abbreviations Continued:

NADH	:	Reduced Nicotinamide Adenine Dinucleotide
PBLa	:	Peak Blood Lactate
PBLa(A)	:	Peak Blood Lactate in Arms only Exercise
PBLa(A+L)	:	Peak Blood Lactate in Combined Arms And Legs Exercise
PDH	:	Pyruvate Dehydrogenase -Complex (1.2.4.1, 1.8.1.4, 2.3.1.12, 3.1.3.43)
PO ₂	:	Partial Pressure of Oxygen
PFK	:	Phosphofructokinase (2.7.1.11)
RtLa	:	Rate of Lactate Turnover
SO	:	Slow Oxidative / Slow Twitch Fibre
SDH	:	Succinate Dehydrogenase (1.3.5.1)
TCA	:	Tricarboxylic Acid
T	:	Trained
TTT	:	Total Test Time
UT	:	Untrained
VO ₂	:	Oxygen Consumption

1.6 Definitions

Fingertip Lactate:

The whole blood lactate reading obtained through enzymatic amperometric measurement of a 20-60 μ l sample of fingertip blood collected via heparinized capillary tube.

Peak Blood Lactate:

The highest blood lactate value obtained from samples collected between 0-3 minutes post exercise.

Subject Population:

All male and female cross-country skiers in Canada named to the Canadian National Cross-Country Ski Team.

Moderately to Highly Trained Endurance Athlete:

Any cross-country skier with an $\dot{V}O_2$ of 59-65 ml kg min

Highly Trained Endurance Athlete:

Any cross-country skier with an $\dot{V}O_2$ of 65-80 ml kg min.

Upper and Lower Body Endurance Trained Athlete:

Any Canadian National Cross-Country Team Member with an $\dot{V}O_2$ of 59-80 ml kg min.

CHAPTER II

Review of Literature

2.1 Introduction

The purpose of this chapter is to review 1) skeletal muscle fibre types, 2) lactic acid production, removal, and turnover, 3) the physiological response, particularly blood lactate to upper and lower body exercise before and after selective endurance training and 4) blood lactate response and other physiological parameters as they are observed in combined arm and leg exercise.

2.2 Skeletal muscle types

Skeletal muscle constitutes the single largest tissue mass of the body, about 40% of the total body weight of the average individual. Separate muscles are composed of fibres united to produce specific muscle movements. Both within and between muscles however, substantial diversification of these fibres has been noted (Burke and Edgerton, 1975).

It has been established that differences exist in the contractile and metabolic properties of skeletal muscle. As a result, various skeletal muscle classification systems

and nomenclature exist to reflect these differences.

Identification of contractile speed from myofibrillar adenosine triphosphate (ATPase activity) is one such system which has successfully demonstrated two main categories of fibres (Gollnick and Matoba, 1984). Type I or slow oxidative (SO) red fibres are known for tonic twitch properties while Type II or fast glycolytic (FG) white are recognized for their phasic twitch properties.

Staining of FG fibres for oxidative enzymes have distinguished them metabolically (Peter, Barnard, Edgerton, Gillespie, & Stemel, 1972). Three subclassifications of type II fibres have been identified namely, IIa, IIb, and IIc (Brooke and Kaiser, 1970), type IIb being the most typical. Table I is a summary table illustrating the functional properties of the two main fibre types (SO and FG) and the subgroups of the FG fibres in human skeletal muscle. This table has been adapted from Karlsson (1979) who emphasizes that the evaluation is schematic and open for criticism (figures representative of experimental results obtained on different populations).

Type I or SO fibres are characterized by a slow contraction (indicated by the time to peak tension) and low glycolytic potential. A characteristically high mitochondrial content and thus oxidative potential in conjunction with

Table 1

**Functional Properties of Slow Oxidative and Fast Glycolytic
Fibres in the Human Skeletal Muscle**

Property	SO Fibre (Type I)	FO Fibre (Type II)		
		FOa	FOb	FOc
Mitochondrial enzyme activities, i.e. oxidative potential	high	inter- mediate	low	high
Activities of enzymes involved in contraction (e.g., actino- myosin ATPase, MK, CPK)	low		high	
Glycogenolytic enzyme activities, i.e., glycogenolytic potential	low	inter- mediate	high	inter- mediate
Phosphagen content				
ATP	high	low	low	low
CP	low	high	high	high
Glycogen content	low	high	high	high
Triglyceride content	high	low	low	low
Electromechanical delay	long		short	
Time to peak tension	long		short	
Peak tension	low		high	
Capillary density i.e. oxygen delivery potential	high	inter- mediate	low	
Myoglobin content	high	low	low	low
Fatigability with short-time explosive activities (< 30 sec.)	small		large	
Fatigability with prolonged muscle activity (> 10 min.)	large		small (if recruited)	
Lactate Dehydrogenase Isozyme	LDH-H LDH-5		LDH-M LDH-1	

* Adapted from Karlsson, 1979.

high Krebs cycle and respiratory chain enzymes provide for terminal oxidation of fuels to carbon dioxide and water.

A more complete catabolism of substrate and subsequent increase in adenosine triphosphate (ATP) yield (Bass, Brdiczka, Eyer, Hofer, & Pette, 1969; Staudte and Pette, 1972) provide for the fatigue resistant nature of the SO fibre. This endurance capacity is further enhanced by comparatively high myoglobin content and capillary to fibre ratio (Karlsson & Jacobs ,1982) in addition to enzyme properties favouring fat catabolism (Essen 1978a ; Jansson, 1980; Lithell, Cedarmark, Froberg, Tesch, & Karlsson, 1981).

In contrast , FG fibre (type IIb) is characterized by a rapid rate of contraction and high peak force output and glycogenolytic enzyme activity. High actinomyosin ATPase, myokinase (MK) and creatine phosphokinase (CPK) activity enhance ATP utilization during muscle contraction as well as replenishment of ATP, adenosine diphosphate (ADP), and creatine phosphates during recovery.

Glycogenolytic enzymes promote the anaerobic capacity of the fibre and reduction of pyruvate to lactate for regeneration of extramitochondrial nicotinamide adenine dinucleotide (NAD⁺) (Thorstensson, 1976). Unlike SO fibres; however, FG fibre can produce high tension for only short periods of time and fatigue easily.

Type IIa fibre, is a highly oxidative FG fibre displaying succinate dehydrogenase (SDH) activity that falls between that of the SO fibre and the type IIb fibre (Brooke & Kaiser,1970). Similarly it possesses intermediate glycogenolytic potential as indicated by its phosphofructokinase or (PFK) activity.

The nature of the type IIc fibre is less obvious. It seems to resemble a fibre type which exists in fetal skeletal muscle and which is also frequently found in muscle of the newborn (Riley, 1973). It has been suggested that it is a primordial type either under development, in a transient state or atrophying (Karlsson, 1979).

Differences in the oxidative, endurance and peak force capacities of SO and type IIb fibres seem to indicate that each fibre may support quite different types of muscular movements. One enzyme in particular, lactate dehydrogenase (LDH), further illustrates this point.

Of the five isozyme forms present in skeletal muscle, the heart form, LDH-H or LDH-5 predominates in type I fibres while the muscle form LDH-M or LDH-1 predominates in type IIb fibres (Sjoden, 1976). LDH-H isozyme promotes oxidation of lactate for fuel while LDH-M favours the reduction of pyruvate to lactate, a necessary step for maintenance of high Embden Meyerhof pathway

activity. As lactate accumulation has been associated with fatigue, the functional differences of SO and FG fibre related to fatigability are understandable.

Recent research by Lannergren (1987) on amphibian *Xenopus* muscle has shown that the division of muscle fibres into FG and SO categories may in some species be an oversimplification. Iliofibularis muscle (an example of *Xenopus* muscle) demonstrated a whole range of fibre contractile properties with a span of V_{max} that was almost 10-fold. It was suggested that myosin heavy chain composition was the major determinant for contractile performance in the *Xenopus* skeletal muscle or type IIX fibres. Existence of the type IIX fibre in mammalian skeletal muscle requires further research before any definitive conclusions may be drawn.

Glycogen depletion studies have facilitated understanding of the relationship between fibre type function and the execution of coordinated movements, through identification of patterns of selective recruitment. (Essen, 1978a).

Glycogen depletion indicates that fibres have been active during some phase of a work bout, contributing to the tension development. Quantitative analyses in human single fibre fragments show, at rest, a slightly greater mean

glycogen content in type II than in type I fibres. At work intensities associated with daily living and with submaximal exercise, glycogen depletion occurs mainly in type I fibres.

With intense exercise however, performed intermittently or continuously, glycogen depletion is present in type I, IIa, and IIb fibres, type II depletion more marked than type I. If all our fibres can be recruited during an exercise bout, it is not unreasonable to suggest that the FG production and SO consumption of lactate could be intimately related to endurance capacity of the individual performing the exercise.

The effect of mode of contraction on neural recruitment has also been investigated. Static tension in excess of 20-30% of maximal voluntary contraction (MVC) initiates recruitment of FG fibre in addition to the SO fibre recruited prior to achievement of that 20-30 % MVC (Gollnick, Karlsson, Piehl, & Saltin, 1974a; Gydikov & Tankov, 1976). During the acceleration phase of dynamic contractions on the other hand, FG units are initially recruited and then grow silent (Grimby & Hannertz, 1977). The greater the tension output, the greater the number of units recruited and the longer the recruitment time. Repeated dynamic exercises such as bicycle work leads to the recruitment of predominantly SO fibre but when exercise intensity is

close to maximal, FG fibres become involved (Gollnick , Armstrong, Sembrowich, Shepard, & Saltin, 1973; Gollnick , Piehl, & Saltin, 1974b ; Gollnick, Piehl, Karlsson, & Saltin, 1975; Essen, 1978b). While progressive exercise involving both static and dynamic contractions would lead to increased recruitment of FG fibre and lactate production, the oxidizing capacity of the SO and type IIa fibres as well as the individuals complement of each fibre, are implicated as factors in the extent of lactate accumulation.

It is generally accepted that the majority of people have roughly 50% type I and 50% type II fibres (Holloszy & Coyle, 1984). Unlike other animals however, it is clear that human fibre composition varies among muscles and within muscles from different individuals (Saltin & Gollnick,1983).

In many animals, muscle is relatively homogeneous with respect to fibre composition consisting of only one or mostly one fibre type. The three fibre types are distributed among muscles in synergistic groups. In extensor antigravity muscle groups, the deepest muscle or muscles in the group usually have a high proportion of SO fibre. In the more peripheral muscles, fast oxidative glycolytic (FOG) fibre and SO fibre are situated primarily in the deep aspect, while FG fibre is more superficial. Such an anatomical arrangement is beneficial in that the fatigue

resistant requirements of the postural muscles can be provided for by their slow twitch fibre composition (Laughlin & Armstrong, 1985).

In contrast to the regional organization of fibre types in animals, human biopsy studies have produced contradictory results. Laughlin and Armstrong in a review paper (1985) suggest that the distribution pattern of fibre types within and among muscles may be less extreme in human leg and thigh muscles but exists nonetheless, FG fibres being more prevalent superficially. Other researchers though have observed a more homogeneous dispersion of fibre types. No difference in fibre complement between superficial and deep sites has been observed in the vastus lateralis (Edgerton, Smith, & Simpson, 1975 ; Johnson, Polgar, Weightman, & Appleton, 1973 ; Elder, Bradenbury, & Roberts, 1982), the gastrocnemius (Johnson et al, 1973; Edgerton et al, 1975) or the soleus, biceps and triceps in human studies (Elder et al, 1982).

Notwithstanding the above consistency between deep and superficial sites, fibre type distributions within sites and between sites have shown few consistent patterns either for different muscles of the same subject or for the same muscle in different subjects (Elder et al, 1982). Biopsies taken from the vastus lateralis in different subjects

identify ranges of 24-85% and 11-53% for low myosin ATPase fibre (Gollnick, Armstrong, Saubert, Piehl & Saltin, 1972, Gollnick et al, 1973). Edgerton et al, (1975) observed variations of 44-95% and 16-86% for the soleus and gastronemius respectively. In spite of subject variation, the mean proportion of SO fibres is high in the soleus relative to other calf muscles (Edstrom & Nystrom,1969; Johnson et al, 1973; Buchthal & Schmalbruch, 1970) and in the vastus lateralis relative to the other quadriceps (Ariano, Armstrong, & Edgerton, 1973).

Another feature differentiating human muscle fibre from other mammals is the prevalence and oxidative capacity of type IIa or FOG fibres . Autopsy studies performed on four leg muscles in thirty two humans (Edgerton et al, 1975) demonstrated that less than 20% of the fibres had high myosin ATPase, oxidative and glycolytic activity whereas percentages greater than 24 and up to 78 have been found in guinea-pigs and rats (Edgerton and Simpson,1969). Although it has been demonstrated that endurance trained athletes generally have a greater proportion of highly oxidative fibres than untrained controls (Gollnick et al, 1972) unlike animals, human FOG fibres generally have an oxidative capacity less than SO fibres.

Although human muscle fibre in comparison to other animals displays more inter and intra site variation, there

does seem to be inter-individual consistency of fibre type distribution in upper and lower body. Belanger and McComas (1985) compared contractile properties in human arm and leg muscles, specifically isometric twitch properties of the brachial biceps and triceps, and anterior tibial and plantar flexor muscles. The brachial triceps had the shortest contraction and half relaxation times and the greatest twitch potentiation, while the plantar flexors had the most prolonged twitches and least potentiation. The anterior tibial and brachial biceps muscles had similar characteristics. Susceptibility to fatigue was less in the plantar flexors and anterior tibial muscle than in the muscles of the upper body. These differences in muscle properties were consistent across 24 subjects.

It was suggested that the relative resistance of the plantar flexors to fatigue would be consistent with the higher incidence of type I fibres in the most powerful muscle in this group, the soleus. These findings are supported by previous observations (Johnson et al, 1973; Elder et al, 1982).

A briefer contraction in the human brachial triceps than in the brachial biceps is consistent with the results of Buchthal and Schmalbruch (1970) who studied small bundles of fibres. Similarly these observations substantiated

findings of Johnson et al (1973) and Elder et al (1982), who demonstrated a higher proportion of type II fibres in the triceps than in the biceps.

In view of the animal research studies documenting the association of muscle function with muscle fibre composition it seems reasonable that human muscles of non weight-bearing limbs contain more fast twitch fibres than lower limb antigravity and locomotory muscles.

Knowing the fatigue resistant nature of SO fibre, it is not surprising that competitive endurance athletes tend to have a higher percentage of type I fibres while individuals excelling in nonendurance events (sprinters, jumpers etc.) tend to have a higher percentage of FG fibres (Gollnick et al, 1972 ; Gollnick & Matoba, 1984). As no studies have shown alterations in percentage distribution of type I and type II fibres with endurance training this phenomenon is probably the result of natural selection, individuals with the best prerequisites for high oxidative capacity becoming successful endurance performers. While genetic endowment may be advantageous, training induced adaptation of skeletal muscle fibres is at least as important to successful performance.

It is understood that endurance training enhances the oxidative capacity of both type I and type II fibres

(Gollnick et al, 1972). Increases in mitochondrial size and number and thus mitochondrial enzyme levels increase the capacity of the fibres to oxidize both fatty acids, and pyruvate (Holloszy & Coyle, 1984). Although SO mitochondrial enzyme levels are twice as high as those found in FG fibre, endurance training has been shown to increase levels of FG oxidative enzymes beyond those found in SO fibres of untrained individuals (Gollnick et al, 1972).

Glycolytic enzymes reveal relatively minor changes with endurance training. In some individuals however, a decrease in total LDH activity with an increase in the proportion of the heart-specific isozyme (LDH-H) and a decrease in the skeletal muscle specific isoenzyme (LDH-M) has been noted (Sjoden, 1976). This adaptation would act to reduce lactate formation and enhance lactate uptake by increasing the ability of the mitochondria to compete with LDH for pyruvate.

An increase in fibre capillary density has also been noted with endurance training (Anderson, 1975; Jansson and Kaijser, 1977). This, in conjunction with the preferential hypertrophy of SO fibre (Gollnick, 1972), will increase the surface area available for diffusion and facilitate oxygen transport to the exercising muscle.

In conclusion, endurance training induces a number of adaptations in skeletal muscle and the significance of this is twofold. Firstly, the same pretraining work rate after training will require a smaller percentage of the muscles' maximal respiratory capacity producing less disturbance in homeostasis. Secondly, there will be an increased utilization of fat with a proportional decrease in carbohydrate utilization during submaximal exercise. These metabolic consequences would increase endurance at pretraining submaximal loads and increase the ability to exercise at a higher percentage of maximal oxygen consumption (MVO_2) in the trained state, by decreasing glycogen depletion and reducing blood lactate levels.

2.3 Lactic Acid Production, Removal, and Turnover During Exercise

Elevated muscle lactate (MLa) and/or blood lactate (BLa) concentration during exercise have been shown to covary with the perception of physical fatigue during strenuous exercise (Karlsson, 1971; Karlsson, 1979; Jacobs, 1981). This has led to the routine determination of BLa during maximal exercise testing, and investigation into its production and removal.

The classic theory of lactic acid production was based on the assumption that lactate formation was almost

exclusively due to a lack of oxygen and anaerobic metabolism at the cellular level (Karlsson, 1971). This was based on the relationship observed between lactate formation and oxygen deficit during exercise, and between onset of lactate efflux and low venous oxygen saturation values in blood flowing from exercising muscle. Recent findings however have raised some questions regarding hypoxia as the sole cause of lactate production. During maximal leg exercise, Pirnay and colleagues (Pirnay, Lamy, Dugardin, Deroanne, & Petite, 1972) obtained blood samples from the deep femoral vein. It was noted that the femoral partial pressure of oxygen (PO_2) did not fall below 10 Torr, and during exercise at about 50% of MVO_2 , PO_2 was between 20 and 40 Torr. The oxygen tension in venous blood was much greater than the critical mitochondrial oxygen tension, its estimated range between 0.1 and 0.5 Torr.

Jobsis and Stainsby (1968) fluorometrically measured intracellular NAD^+ in isolated dog muscle and concluded that oxygen supply did not limit respiratory chain activity. When the muscle preparations were stimulated to contract at exercise intensities sufficient to produce maximal oxygen consumption and a significant efflux of lactate, the $NADH:NAD^+$ ratio (an indicator of the mitochondrial redox state), reflected a greater degree of oxidation than was present in resting conditions.

A second theory of lactate production evolved from the research findings of Connett and coworkers (Connett, Gayeski, & Honig, 1984). Connett et al observed lactate accumulation in dog gracilis during mild (10% $\dot{M}V\text{O}_2$) exercise and up to a contraction rate which elicited 70% of $\dot{M}V\text{O}_2$. Lactate accumulation was found to relate linearly to twitch (work) rate. In addition, lactate accumulation was not reduced by increasing blood flow or inducing capillary dilation. The minimum PO_2 did not drop below 2 Torr, a value significantly above the critical mitochondrial oxygen tension. It was concluded that lactate accumulation was related to increments in work and metabolic rate.

The second theory of lactate production then attributes rises in plasma lactate concentration to an increasing use of glycolytic metabolic pathways due to progressive recruitment of glycolytic muscle fibres (Jones and Ehram, 1982). This theory appears more plausible for exercise conditions than the classical theory and is also biochemically sound. During exercise, the major factor determining the energy requirement is the rate of ATP hydrolysis at the cross bridges formed between actin and myosin in the contracting muscles (Holloszy & Coyle, 1984). The rising ADP concentration accelerates the rate of all reactions that utilize ADP to generate ATP. The ADP concentration continues to rise causing greater and greater acceleration of the rate of formation of triose phosphates

until the rate of ATP production matches the rate of ATP utilization.

With increasing exercise intensity, the requirement for accelerated substrate catabolism necessitates the recruitment of FG fibres with their characteristically rapid Embden - Meyerhof pathway (McGilvery, 1979). As the workload on these cells increase, the rising ADP concentration accelerates the formation of pyruvate and reduced nicotinamide adenine dinucleotide (NADH) in the cytosol exceeding the respiratory capacity of the mitochondria. The high pyruvate concentration and increased ratio of NADH/NAD⁺ will lead to preferential conversion of pyruvate to lactate rather than oxidation of pyruvate in the tricarboxylic acid (TCA) cycle or conversion to alanine by alanine transaminase. More specifically NADH generated in the cytosol is converted back to NAD⁺, not by the glycerol phosphate or malate-aspartate electron shuttles characteristic of oxidative phosphorylation, but rather by reducing pyruvate to lactate (Holloszy & Coyle, 1984). Rising lactate concentration then is a signal that a rising ADP concentration has increased the formation of pyruvate and NADH more than it has the oxidation of pyruvate and NADH (McGilvery, 1979).

The association of rises in plasma lactate with the progressive recruitment of FG fibre, rather than with an

oxygen deficient state seems to be the relationship providing the best explanation for lactate production in exercise conditions. It is possible however, that reductions in oxygen delivery can influence lactate production in certain situations.

Based on observations of the correlation between oxygen deficit and lactate concentration in working muscles, Karlsson (1979) identified two exercise conditions where oxygen transport may be reduced; at the start of exercise and until steady state level is obtained, and with supramaximal loads. At low levels of exercise, plasma concentrations of lactate remain unchanged. With moderate levels of exercise, lactate is found to rise for the first few minutes and then declines. At heavy levels of exercise, lactate increases and then plateaus, or continues to rise until exhaustion. A relative lack of oxygen caused by increasing intensity of exercise dictates a shift in ATP production, from an aerobic, to an anaerobic production. Lactate production in this sense, is a metabolic product reflecting an imbalance of oxidative enzyme activity, a change in fibre type recruitment and, reduction in oxygen delivery. In conclusion, it is inaccurate to suggest that hypoxia is the sole cause of lactate production in the exercise state. Closer consideration of the FG fibre recruitment theory then is necessary if a true understanding of exercise associated lactate mechanics is to be

discovered.

Lactate is known to be a relatively small and easily diffusible molecule. It is assumed, mainly from animal studies, that lactate diffuses freely and rapidly into all water compartments of the body (Hermansen & Stensvold, 1972). As previously mentioned, lactate can also be "consumed" or oxidized by SO fibre. The BLa concentration at rest and during exercise then is dependent on several factors:

- (1) rate of lactate production
- (2) rate of lactate diffusion from the cells to the blood
- (3) rate of lactate removal

As lactate production is associated with FG fibre recruitment and work intensity, one can see how rate of increase in work and duration of work may affect rate of lactate release. Intense muscular exercise leading to exhaustion within a time range of 30 seconds to 10-15 minutes has shown to elicit maximal values for MLa accumulation (Karlsson, 1971). Peak values for BLa concentrations are obtained when performance durations exceed three to four minutes. When maximal performance duration is greater than 10-15 minutes, proportionately lower MLa and BLa concentrations are found.

Standardized work loads performed after prolonged heavy exercise lasting 2-4 and 5-7 hours respectively have shown decreased BLa concentrations but normal MLa concentrations except with brief maximal work loads after extremely prolonged heavy exercise (Karlsson, 1971). It was suggested that the prolonged heavy exercise led to increased utilization of blood-borne lactate, a factor which might enhance lactate flux from the working muscle. Karlsson concluded that the rate of disappearance of lactate from muscle and blood would be increased and the effect would be most pronounced during submaximal and maximal work with a relatively prolonged work duration, i.e., 5-10 minutes.

While the highest MLa concentrations, the highest rate of lactate release and the highest BLa values have been noted after brief, single, exhaustive dynamic work, release of lactate is not solely a function of intramuscular concentrations. Lactate uptake and transport across cellular membranes are subject to saturation kinetics (Mazzeo, Brooks, Schoeller, & Budinger, 1986). When the MLa concentration is in the order of $4-5 \text{ mmol} \times \text{kg}^{-1}$ a plateau is reached for the lactate release and/or removal (Jorfeldt, Juhlin-Dannfelt, & Karlsson, 1978). A further increase in MLa concentration will not induce a more rapid release. Lactate thus accumulates in an accelerating manner within the active muscles.

As lactate production and release are affected by intensity and duration of exercise, so is the rate of lactate removal. Lactate is always produced, even in well oxygenated resting individuals. The low, steady state BLA concentrations in resting individuals however lead to the false conclusion that lactate is not being produced in the resting individual. On the contrary, lactate levels are low and stable in the resting individual because production is balanced by removal. In recent literature, this resting balance has been referred to as turnover (Brooks, 1985a). More specifically, turnover is the rate of metabolic renewal. Because in the steady state the processes of lactate production are balanced by the processes of removal, there is an equivalence of turnover, appearance and disappearance.

Lactic acid turnover studies have demonstrated the importance of lactate as an important precursor for hepatic glycogenolysis. McGarry and associates (Katz & McGarry, 1984 ; Foster, 1984 ; Newgard, Hirsch, Foster, & McGarry, 1983) observed rats refed after fasting and found much of the glucose from dietary carbohydrate bypassed the liver and reached the peripheral tissues where it was cleaved to lactate and released into the venous circulation. Arterial lactate rather than portal glucose seemed to be the preferred precursor for liver glycogen synthesis. Lactic acid then is an indirect product of carbohydrate digestion and is

a means of shuttling oxidizable substrate and gluconeogenic and glycogenic precursors between cells, tissues and organs.

Oxidation is also a major means of lactate catabolism. In recent articles by Brooks (1985a,1986) studies observing rates of lactate turnover (R_{tLa}) and oxidation in resting rats, dogs and humans were reviewed. Studies reporting on lactate oxidation in resting mammals demonstrated active lactate turnover with approximately 50% removed through oxidation. Furthermore, under resting, post-absorptive conditions, the quantity of lactate oxidized represented approximately 50% of the total carbohydrate combusted. Even under resting conditions then, lactate oxidation makes a meaningful contribution to the total supply of oxidizable substrate.

Studies on the turnover of lactic acid in animals during exercise have revealed a direct relationship between lactate turnover and metabolic rate as given by the rate of oxygen consumption (VO_2), (Depocas, Minaire, & Chattonnet, 1969; Eldridge, 1975; Eldridge, Tso & Chang, 1974; Issekutz, Shaw & Issekutz, 1976). Using continuous infusion technique and ($U -^{14}C$) lactate, the aforesaid researchers demonstrated elevated lactate turnover in dogs during exercise compared with rest. Donovan and Brooks (1983) observed a correlation of 0.86 between lactic acid turnover and VO_2 in both trained and untrained rats. A point of great interest in

these studies of metabolite kinetics during exercise is that lactate turnover and oxidation (Donovan & Brooks, 1983) exceed glucose turnover and oxidation (Brooks & Donovan, 1983; Brooks, 1985b).

Lactate tracer studies performed on humans have come to similar conclusions (Jorfeldt, 1970; Hubbard, 1973; Mazzeo, Brooks, Budinger, & Schoeller, 1982; 1986). Mazzeo et al (1986) confirmed a linear relationship between lactate turnover and VO_2 in humans during submaximal work up to 75% of MVO_2 . It was suggested that oxidation was the major pathway for the removal of exercise produced lactate. At rest, the estimated percent oxidation was 49.3. During 2 hours of easy exercise, percent oxidation increased to 87.0 whereas during 45 minutes of hard exercise, percent oxidation was 79.9. Furthermore, during exercise, the calculated rates of lactate release were significantly greater than during rest.

In addition to confirming the relationship between lactate turnover and graded exercise, human tracer studies strongly suggested that skeletal muscle is an important site of lactate catabolism (Hubbard, 1973; Mazzeo et al, 1986). Both contracting and inactive skeletal muscle can extract lactate from the arterial circulation (Stanley, Gertz, Wisneski Neese, Morris & Brooks, 1986). Oxygenated

working skeletal muscle tissue then, has the capacity for simultaneous production and utilization of lactate. This fact has been demonstrated by Jordfeldt (1970) where (U-¹⁴C) lactate was infused into the brachial artery and venous blood was collected. The results indicated that a significant portion of the tracer dose was taken up and combusted to carbon dioxide (CO₂) within the contracting skeletal muscle.

It has been suggested that 50% of lactate removed by the exercising muscle is immediately catabolized to CO₂ and thereby used as fuel (Ivy, Withers, Van Handle, Elger, & Costill, 1980). With this in mind, it is possible that lactate produced by FG fibres in a specific muscle may be locally oxidized by SO fibres without ever being released into the blood (Mazzeo et al, 1986 ; Essen, Pernow, Gollnick, & Saltin, 1973).

While skeletal muscle is the primary site for oxidation of lactate, heart tissue is also capable of this role (Gertz, Wisneski, Neese, Bristo, Searle, & Hanlon, 1981). The presence of the LDH-H isoenzyme in this muscle makes conditions favourable for the conversion of lactate to pyruvate and subsequent entry into the TCA cycle.

The relative roles played the liver and kidney in lactate uptake have also been investigated. During submaximal and maximal exercise, Hermansen and Stensvold (1972)

calculated lactate removal by liver to be 4-8% of the total amount of lactate eliminated. The kidney can remove lactate from the circulation by metabolic processes (complete oxidation and gluconeogenesis) and by renal excretion. No measurements of lactate uptake by the kidney during exercise in man have been published (Hultman and Sahlin, 1981). However, according to Carlesten and coworkers (Carlesten, Hallgren, Jagenburg, Svanborg, & Werko, 1961) and Krebs and coworkers (Krebs, Love, Bratvold, Trayser, Meyer, & Fischer, 1964) the heart and kidney together can remove a maximum of 10% of the total lactate produced. The amount of lactate excreted through urine is thought to be very small, probably less than 5% of the total amount removed (Johnson and Edwards, 1937). Liljestrand and Wilsson (1925) measured the lactate output in urine in 10-minute sampling intervals before and after exercise. They found a maximum lactate output (0.7 mmol/min) in the second 10-minute urine collection after a shortlasting exercise. Total output after a 2 minute exercise was 15.2 mmol lactate during a 45 minute period of urine sampling. Comparable figures, 10 mmol lactate excretion during a 45 minute recovery were found by Johnson and Edwards (1937).

On the basis of the literature reviewed it can be concluded that during exercise, the main route of lactate removal is through skeletal muscle oxidation. Knowing the effect of endurance training on skeletal muscle fibre one

might also conclude that lactate turnover would be enhanced with endurance training. According to the literature, however, this may not be the case.

It is well known that endurance training reduces the accumulation of lactic acid in blood and skeletal muscle during exercise at pretraining absolute or relative work rates (Holloszy & Coyle, 1984). Several theories explaining this phenomenon have been proposed (Donovan & Brooks, 1983). Lactate production may be reduced in trained individuals as a result of a shift from carbohydrate toward lipid utilization. Lactate production might also be reduced by the decrease in the total amount of LDH in muscle as well as the LDH-M isozyme. Finally, trained (T) individuals might demonstrate greater lactate removal.

Donovan and Brooks (1983) used primed continuous infusion of 2-³H and U-¹⁴C lactate to study the effects of endurance training on lactate metabolism during conditions of rest, easy exercise, and hard exercise. It was found that lactate turnover rates (RtLa) did not differ significantly between untrained (UT) controls and T animals. Furthermore, T animals oxidized a slightly smaller fraction of the lactate removed during hard exercise, while at the same time, incorporating a greater amount of (U-¹⁴C) into glucose. It was suggested that during hard exercise, T animals relied less on the oxidation of carbohydrates and

were able to conserve the carbon skeleton through enhancement of alternative pathways (ie. gluconeogenesis).

As T animals exhibited lower BLa levels at any given RtLA, the metabolic clearance rate of lactate was enhanced. T animals were capable of matching their rates of lactate removal to lactate production at a lower BLa concentration than UT animals which had to tolerate an elevated BLa level to sustain a given removal rate. It was concluded that endurance training affected lactate clearance, not lactate production.

These results are in contrast to those of Freminet and coworkers (Freminet, Poyart, Bursaux, & Tablon, 1975) who reported that training caused significantly increased lactate turnover as well as oxidation of a greater fraction of the lactate flux. While increased lactate turnover cannot explain lower submaximal lactate levels, neither can an increased oxidation of lactate, T and UT individuals having similar oxygen consumptions at any given submaximal workload. One can see that lactate metabolism, particularly under exercise conditions, is one area worthy of future research.

Certain other factors affecting BLa levels deserve brief mention. Glycogen depletion induced in one leg prior to two legged exercise, resulted in an increase of lactate uptake

by the depleted leg during two legged exercise (Essen et al, 1973). Thermal dehydration (England, Powers, Dodd, Cualender, & Brooks, 1984) caffeine ingestion (Gaesser and Rich, 1985) and being female (Fox & Mathews, 1981) seem to accelerate the onset of blood lactate accumulation. When studying lactate metabolism then, these factors would have to be taken into account.

2.4 Upper Body and Lower Body Exercise and Lactate Responses

SO fibres are lactate consumers and FG fibres are lactate producers. The BLA concentration during exercise represents the balance between its oxidation and production. Ivy et al (1980) observed that the percent of SO fibres was related to the absolute and relative lactate thresholds (LaT), the work rate at which BLA accumulation begins. It was suggested that the ratio of SO to FG fibres may exert a genetic influence over the LaT and possibly control the range in which relative LaT can shift. If skeletal muscle fibre composition is the determinant of the absolute and relative LaT, then variations in the size of the exercising muscle mass should not influence LaT values providing the added muscle mass is of the same fibre composition and is exercising at the same relative load.

Stamford and colleagues (Stamford, Weltman, & Fulco,

1978) examined LaT (otherwise known as anaerobic threshold) and cardiovascular responses during one versus two-legged cycling. Exercise was initiated at 25 watts and increased by 25 watts every 3 minutes to maximal work output. At each workload VO_2 , CO_2 production, BLA concentration, minute ventilation, respiratory exchange ratio, heart rate, cardiac output, stroke volume, and arteriovenous oxygen difference were determined. It was found that while absolute differences existed at different work levels, each of the aforementioned variables was similar during one versus two-legged cycling when expressed as relative percentage of MVO_2 . Anaerobic threshold (AT) for both one and two-legged cycling was approximately 48% MVO_2 when interpreted from graphic presentation. This indicated that the size of the exercising muscle mass did not necessarily influence the determination of AT when expressed on a relative basis. It was suggested that differences in relative AT across modes of exercise are not necessarily related to the size of the exercising muscle mass. Factors such as task familiarity; muscle composition relative to fibre type and respective aerobic versus anaerobic energy potential; and local vascular development however may be influential. These results are in agreement with others previously reported (Gleser, 1973; Saltin, Nazar, Costill, Stein, Jansson, Essen, & Gollnick, 1976).

While one and two-legged exercise produce no significant differences in relative LaT, this is not the case in arm versus leg exercise.

At the same relative submaximal VO_2 , BLa concentration during arm exercise is significantly greater than BLa concentration during leg exercise (Bevegard, Freyschuss & Strandell, 1966; Freyschuss & Strandell, 1967; Klausen, Rasmussen, Clausen, & Trap-Jensen, 1974). Regardless of upper body muscle mass being significantly less than lower body muscle mass, identical relative workloads elicit higher lactate values.

Research indicates that at a given submaximal workload, arm exercise is performed at a greater physiological cost than leg exercise (Franklin, 1985). At a given power output, heart rate, systolic and diastolic blood pressure, minute ventilation, VO_2 , respiratory exchange ratio, and BLa concentration are higher, while stroke volume and anaerobic threshold (the latter expressed as a percentage of aerobic capacity) are lower during arm exercise compared with leg exercise (Astrand, Ekblom, Messin, Saltin, & Stenberg, 1965; Bevegard et al, 1966; Bobbert, 1960; Davis, Vodac, Wilmore, Vodac & Kurtz, 1976; Fardy, Webb, & Hellerstein, 1977; Franklin, Vander, Wrisley, & Rubinfire, 1983; Schwade, Blomquist, & Shapiro, 1977; Stenberg, Astrand, Ekblom, Royce, & Saltin, 1967). Since cardiac output is nearly the

same in arm and leg exercise at a given $\dot{V}O_2$ (Asmussen & Nielsen, 1947) the elevated blood pressure during arm exercise is believed to reflect increased peripheral vascular resistance (Stenberg et al, 1967).

Sawka (1986) uses Poiseuille's equation to explain the mechanism of increased peripheral vascular resistance (R). According to the equation, flow (F) is the quotient of driving pressure (P) divided by the resistance to flow (R). By transposition, $R = P/F$ and $P = R \times F$. If arm cranking produces higher blood pressure than leg cycling at a given $\dot{V}O_2$, then R must be proportionately higher to elicit the same F during upper body than during lower body exercise. As absolute muscle blood flow is approximately equal during arm crank and cycle exercise performed at the same $\dot{V}O_2$, (Clausen, 1973), a greater total peripheral resistance must account for the elevated blood pressure response in arms only exercise.

Smaller upper body skeletal muscle mass and vascular cross-sectional area may also influence peripheral vascular resistance as vessel radius is a primary factor influencing R (Sawka, 1986). The smaller vascular cross-sectional area of the upper body being perfused by the same F will result in a greater R. Also, an increased sympathetic response to arm crank exercise will lead to increased vasoconstrictor tone

in the non-exercising muscles and further contribute to an increased R . Vasoconstriction in legs during arm work represents a more pronounced elevation in peripheral resistance than vasoconstriction in arms during leg work owing to the difference in the size of these two vascular beds (Astrand et al, 1965).

It has been suggested that the mechanical inefficiency of upper body exercise could be responsible for the increased vasoconstrictor tone and elevated total peripheral vascular resistance. Mechanical efficiency (i.e., the ratio between the output of external work and caloric expenditure of VO_2) is lower during arm exercise than leg exercise (Fardy et al, 1977; Stenberg et al, 1967). This may reflect the static effort required with arm work, which increases VO_2 but does not affect the external work output. Static or isometric contractions may be defined as contractions where muscle length remains unchanged while producing tension (Sale and Norman, 1982). In comparison to cycle exercise, arm crank exercise may involve a greater isometric exercise component for torso and hand stabilization than legs only exercise and therefore increase blood pressure.

While the above explanations may in part explain the different cardiorespiratory and haemodynamic responses in arms only (A) exercise versus legs only (L) exercise, they

do not account for the different metabolic exercise responses observed (i.e., significantly higher blood lactates in upper body exercise). While research investigating the relationship between sympathetic and metabolic responses may be inconclusive an argument in support of this relationship can be put forth.

If one is to assume that upper body exercise does incorporate an element of isometric work, an association between the pressor (blood pressure) response and the metabolic response can be made. Petrofsky and coworkers (Petrofsky, Phillips, & Lind, 1981) in observing anaesthetized cats revealed that the pressor response to sustained isometric contractions is due predominantly to the activation of FG muscle fibres. During contraction of the soleus muscle, wholly comprised of SO fibres, no increase in blood pressure is apparent. In muscles with mixed populations of fibre types such as the gastrocnemius, the pressor response is similar to that found in voluntary contractions in man. Thus, upper body exercise might require not only a greater isometric component but a greater recruitment of FG motor units than lower body exercise. Recruitment of predominantly FG fibre during upper body exercise then could account for the cardiorespiratory and haemodynamic responses observed in A exercise as well as explain the higher levels of blood lactate achieved in A versus L exercise.

It is true that in man, static or isometric exercise, particularly that involving the upper limbs, causes increased sympathetic and decreased vagal outflow. As a consequence, cardiac output, contractility of the left ventricle, heart rate and systemic arterial pressure (both systolic and diastolic) are increased (Shepherd, Blomqvist, Lind, Mitchell, & Saltin, 1981). As no effort has been made to quantify this static component however, it is difficult to estimate to what degree it is responsible for the observed physiological adaptations to arm exercise. Furthermore, it is hard to justify classification of arm cranking or arm cycling as a purely static exercise; most muscular exercise is neither purely dynamic nor purely static (Shepherd et al, 1981).

While an association between BL_a and sympathetic nervous system stimulation is possible, it seems unlikely that a cause and effect relationship exists. A more complete anatomically and metabolically oriented theory for lactate production should be sought.

Local arteriovenous oxygen differences are substantially lower during arm exercise than during leg exercise (Klausen et al, 1974). Klausen and coworkers suggested that an increased lactate production by A exercise versus L exercise could be explained by the lower ability of the arms to utilize oxygen or by a greater percentage of the local blood

flow going to skin and bone in A exercise than L exercise. As Klausen et al (1974) presented no mechanism of action whereby blood flow directed to skin and bone would be greater during A exercise than during L exercise it is difficult to evaluate the validity of this assumption. If an increased skin perfusion of blood is a mechanism by which venous blood temperatures can be decreased during exercise, it would seem that leg exercise would produce a substantially greater perfusion of skin tissue due to its larger surface area.

It has been suggested that fibre type may have an influence on muscle blood flow (Laughlin & Armstrong, 1985). FG fibre blood flow does not show the initial overshoot response to low intensity exercise. With high intensity exercise furthermore, FG fibre blood flow does not increase as rapidly as does blood flow to FOG and SO fibres. Assuming that the upper body is composed of predominantly FG fibre, it is possible that muscle blood flow during A exercise is relatively less than during L exercise, yet this cannot account for the magnitude of the lactate difference observed during each mode of exercise.

Klausen's theory (Klausen et al, 1974) that lactate production during A exercise is a result of the lower ability of the arms to utilize oxygen is sound, yet it is somewhat incomplete. Knowing the difference in the

distribution of fibre types between upper and lower body, a more in depth explanation for the differences in A and L exercise responses can be formulated.

As human upper limbs seem to be comprised of a proportionately higher percentage of FG fibre than lower limbs, and lower limbs present a higher proportion of SO fibre, it could be suggested that high BLA associated with A exercise are a result of a greater recruitment of FG fibre.

At a given submaximal load, A exercise would generate a higher BLA than L exercise for the following reasons. To achieve the same absolute VO_2 , the intensity of A exercise would be significantly greater than the intensity of L exercise due to the smaller muscle mass of the upper body. A high intensity of work would necessitate recruitment of FG fibre, the number of fibres recruited being proportionately greater than that recruited during L exercise due to the fibre composition of upper body limbs. Relatively fewer SO fibres and a smaller exercising muscle mass during A exercise as opposed to L exercise would result in a lower consumption of lactate by arms in A exercise than legs during L exercise. Observations of a higher negative arterio-venous lactate difference in A exercise than in L exercise supports this assumption (Freyschuss & Strandell, 1967).

With respect to resting limb lactate values during upper or lower body exercise, Freyschuss and Strandell (1967) observed that venous lactate values were significantly less than arterial lactate levels indicating lactate uptake by resting extremities during exercise. As would be anticipated, lactate elimination by resting legs was substantially greater than lactate elimination by resting arms during A and L exercise respectively. At two successive submaximal loads, resting legs eliminated 22% and 39% of arterial lactate passing through them, while resting arms eliminated only 11% and 27%. On the basis of fibre type composition and amount of exercising muscle mass, a higher BL_a in A versus L exercise at the same $\dot{V}O_2$ can be understood.

Vokac et al (1975) studied the effect of L exercise and of A exercise in sitting and standing positions on energy output and cardiorespiratory parameters in seven male subjects. Although lactate elimination by resting limbs was not directly determined, peak blood lactates (PBL_a) 2 minutes post exercise were examined. Mean blood lactates in L cycling, sitting arm cranking and standing arm cranking were 15.2 ± 1.4 mmol/l, 13.9 ± 2.1 mmol/l and $11.0 \pm .9$ mmol/l respectively. While the postural variations in A exercise did not produce significant differences in mean blood lactates ($p < 0.01$), utilization of postural leg muscles in arm cranking did serve to lower mean lactate

values when compared to arm cranking in the sitting position. Of even greater interest however is the fact that a 13% higher workload was achieved at maximal effort in the standing versus the sitting arm cranking position. Vokac and coworkers (1975) attributed these differences to increased efficiency in the standing position however oxidation of arm lactate by SO fibre in postural leg muscles could also be a plausible explanation.

As endurance training has proven to increase the oxidative capacity of both FG and SO fibres it is logical to question how endurance training would affect the A and L exercise responses. Klausen and co-workers (1974) studied two groups of healthy young male subjects exposed to arm training and leg training respectively for five weeks. Before and after training, the concentration of lactate in arterial and venous blood from exercising extremities was studied during 15 minutes of light and heavy A and L exercise. It was found that the lactate concentration in arterial blood and veno-arterial lactate differences were significantly decreased during exercise with trained muscle groups. The arterial lactate concentration and the veno-arterial lactate difference were always greater during A exercise than during L exercise at the same relative and absolute workload. Training did not affect this relationship.

Pendergast and colleagues (1979) compared eight

kayakers and three sedentary subjects performing arm cranking at several workloads ranging from submaximal to the highest they could sustain for 2 minutes and for intervals varying from 10 seconds to 5 minutes. Compared to the sedentary group, glycolytic arm work in the kayakers was characterised by : 1) higher thresholds for release of lactate at the onset of submaximal work; 2) lower BLa concentrations during comparable absolute or relative submaximal work; 3) higher conventional anaerobic thresholds for absolute but not relative workloads; 4) higher maximal rates of lactate release; and 5) the same maximal BLa concentrations.

Although training of upper body limbs does improve the oxidative capacity of upper limb skeletal muscle, the higher arterial lactate concentrations achieved in A exercise versus L exercise remain unaffected.

It has been suggested that the margin for improvement of oxidative capacity may be greater for arms than for legs following endurance training. This is in view of reportedly lower oxygen utilization coefficients for equivalent workloads in UT arms compared to UT legs of sedentary subjects and increased arm but not leg arteriovenous oxygen differences following arm and leg training respectively (Clausen, Klausen, Rasmussen, & Trap-Jensen, 1973; Saltin et al, 1976). Holloszy and Coyle (1984) report that although

Type II fibres have the lowest capacity for aerobic metabolism in the untrained state, they may undergo a fourfold or greater increase in mitochondria in response to strenuous endurance training. Regardless of this capacity for improvement, the oxidative ability of upper limbs cannot exceed that of lower limbs following endurance training.

The significance of the differences in fibre type composition, absolute mass of muscle and physiological response to exercise in upper and lower limbs become even more apparent when the cross-over benefits of training one set of limbs to the untrained set of limbs are investigated.

Following endurance training by one limb or a set of limbs, T limbs demonstrate a decrease in venous and arterial lactate concentrations as well as a decrease in blood lactate venous arterial difference. Decreases in submaximal load heart rate, VO_2 , respiratory exchange ratio and minute ventilation, and increases in venous pH have also been noted at the same absolute submaximal load post-training (Clausen, Klausen, Rasmussen, & Trap-Jensen, 1971a; Clausen, Klausen, Rasmussen, & Trap-Jensen, 1971b; Clausen et al, 1973). Increases in arteriovenous oxygen difference have been observed in T arms but not in T legs (Clausen et al, 1971b; Clausen et al, 1973; Magel, McArdle, Toner, & Delio, 1978; Saltin et al, 1976). These limb-specific training effects imply that a substantial

portion of the conditioning response is due to extracardiac or peripheral adaptations occurring in T limbs alone. These peripheral or local training induced adaptations have been previously identified as increased mitochondrial density, oxidative enzyme activity, myoglobin concentration and capillarization, as well as decreased limb blood flow.

This principle of training specificity however, has been argued on the basis of changes observed in UT arm exercise response following leg training. Klausen and colleagues (1974) noted a decrease in venous and arterial BLA concentration in UT exercising arms following leg training. No change in blood lactate venous-arterial difference was noted. Clausen and coworkers (1971b) noted a decrease in respiratory exchange ratio and heart rate, an increase in cardiac output at heavy loads and no change in arteriovenous oxygen difference or hepatic blood flow. Increases in MVO_2 of UT arms following leg training has also been demonstrated (Clausen et al, 1973; Rosler, Hoppeler, Conley, Claassen, Gehr, & Howald, 1985)

In contrast to the changes in arm exercise response post leg training, arm training produces few if any changes in UT leg exercise response. Clausen and coworkers (1971a, 1971b) observed a decrease in heart rate and a small decrease in BLA during leg exercise following arm training. No change in VO_2 , respiratory exchange ratio, or minute

ventilation at submaximal loads were seen.

These transfer effects occurring during work by UT arms following leg training have been attributed to cardiovascular adaptations (specifically increased stroke volume) which permit a greater oxygen uptake by the UT muscles during activity (Clausen et al, 1973).

While important peripheral adaptations occur in response to training of upper or lower limbs, central circulatory adaptations resulting specifically from lower body training have also been demonstrated (Clausen et al, 1973). Peripheral and central circulatory changes are most apparent however during arm exercise following arm training and following leg training respectively.

The transfer effect studies above highlight the difference in fibre type composition, absolute mass of muscle and physiological response to exercise in upper and lower limbs. Upper body with a higher complement of FG fibre will demonstrate a greater peripheral adaptation to endurance exercise than the lower body with its already high composition of SO fibre and oxidative capacity. Lower body endurance training in comparison, will induce a central training effect, the large contractile mass of the lower limbs increasing venous return and stroke volume thereby facilitating oxygen uptake by T and UT muscles.

While many researchers have evaluated the effects of upper body endurance training or lower body endurance training on exercise lactate response, none to date have investigated the effects of combined upper and lower body endurance training on lactate production. The combination of peripheral and central endurance training adaptations could markedly alter the physiological response to upper or lower body exercise, and combined arm and leg (A+L) exercise as discussed in the following section.

2.5 Lactate Response in Combined Arm Plus Leg Exercise

The arterial lactate concentration and veno-arterial lactate difference are always greater during A exercise than during L exercise at the same relative and absolute workload. This relationship is unaffected by training. Peak BLa values after an exhaustive all-out effort however, are significantly higher in L exercise than in A exercise (Vokac et al, 1975). Again, this relationship is unaffected by endurance training (Secher et al, 1974)

As the larger muscle mass of the lower limbs produces a higher peak lactate at the end of a maximal exercise effort than do the upper limbs, it would seem logical to assume that a combined arms and legs exercise effort

would produce blood lactate values that were higher still. Interestingly enough the following review will show that this is not the case.

Freyschuss and Strandell (1967), observed axillary and femoral arteriovenous oxygen and lactate differences in three healthy young males during A, L, and A+L exercise using percutaneous catheters. Graded exercise was performed in the supine position on two electrodynamically braked bicycle ergometers which could be use separately or simultaneously, one for the arms and one for the legs. Each type of exercise was carried out as an uninterrupted series of two workloads of increasing intensity, each one lasting 6-7 minutes, with blood samples drawn between 5-7 minutes. In all instances, the loads were submaximal. It was discovered that there was no significant difference in the arterial lactates during L exercise and A+L exercise.

Previously, Bevegard and his aforementioned coworkers Freyschuss and Strandell (1966) had observed the adaptations to A, L, and A+L exercise by cardiac catheterization in supine and sitting positions in six healthy young males. Test protocols were similar to those presented in the above study. No significant difference in the arterial lactates during L and A+L exercise had been found.

Noting these observations, Freyschuss and Strandell

(1967) suggested that during the A+L exercise, a net uptake of lactate by the exercising legs occurred, thereby lowering the A+L exercise lactate values to equal those obtained in the L exercise. At the lowest workload this seemed to be the case, a positive arteriovenous lactate difference existing over the legs at the sixth minute of exercise. Based on mean lactate values obtained after 6 minutes of light arm exercise, the authors estimated a fivefold increase of lactate uptake in the legs. Even at the heaviest A+L exercise, lactate utilization was still observed in one subject despite a work level which should have caused considerable lactate production in the working legs as well. This positive arteriovenous lactate difference was not observed during the other modes of exercise. During separate A and L exercise, all 12 observations showed a negative arteriovenous lactate difference over the working limbs and more so for the arms than for the legs at the same level of oxygen uptake.

During A+L exercise, Freyschuss and Strandell also observed that the calculated lactate releases from the limbs at the sixth minute of work were less than the values predicted from the workloads and the observations during separate A and L exercise. It was suggested that the A+L exercise condition accelerated the achievement of a metabolic steady state by decreasing the dependence on anaerobic glycolysis at the beginning of the workload.

Another physiological parameter evaluated that may assist in the understanding of this phenomenon were the arteriovenous oxygen differences observed during each mode of exercise. In L exercise the oxygen saturation in the femoral vein decreased gradually and reached a lower value than that noted in the axillary vein during A exercise, even when differences in oxygen uptake were considered. During A+L work, the oxygen saturation of the axillary vein was lower and the axillary arteriovenous oxygen difference higher than during A exercise at the same level of arm work. This was true for all the six observations. The axillary arteriovenous oxygen difference at the heaviest A+L load was on the average 22% higher than that expected during A exercise at the same arm workload. Similar relationships were observed in five out of six comparisons of L versus A+L exercise, but the mean difference in absolute figures was somewhat smaller.

Although Freyschuss and Strandell (1967) did not study lactate turnover, their BL_a observations seemed to support the turnover theory proposed by Donovan and Brooks (1983) and their conclusions can be justified.

With the addition of lower body exercise to upper body exercise one could argue that there would be a proportionate increase in BL_a values. Donovan and Brooks (1983) however, noted that rising BL_a concentrations increased BL_a removal.

Furthermore, the addition of lower body muscle mass to arm exercise would enhance removal owing to its large volume and high proportion of SO fibre. This idea has been supported by Green and co-workers (Green, Houston, Thomson, Sutton, & Gollnick, 1979) in their study of intermittent bouts of supramaximal arm exercise performed during prolonged submaximal leg work. Following arm work a significantly higher lactate concentration in the vastus lateralis muscle was observed when compared to the L condition. This elevation in intramuscular lactate represented an increase in uptake by the muscle as substantial blood elevations occurred following arm work.

Lower calculated lactate release in A+L exercise can also be explained on the basis of immediate lactate uptake. It is possible that lactate produced by FG fibre in the lower limbs was immediately taken up by SO fibre, never even entering the blood. Although blood flow to limbs would be compensated during A+L exercise due to the need for a more widespread circulation, no hypoxic conditions would occur. This is a result of the increased efficiency of oxygen extraction as indicated by oxygen saturation and arteriovenous oxygen difference values. Freyschuss and Strandell (1967) attributed this increased efficiency to an increased uniformity of muscle blood flow during exercise in relation to metabolic demands, to an enhanced diffusion

from blood to muscle cells, or to both these possibilities. This explanation seems valid as a more widespread circulation would increase the number of open capillaries and therefore the surface area available for diffusion.

A+L exercise responses have also been investigated in T individuals. Astrand and Saltin (1961) observed two well trained and five active subjects performing maximal work of various types. All A+L exercise protocols (cycling, skiing and swimming) elicited lactate values that were lower than those seen in legs only cycling and running. Although BLa's were similar for A+L and L exercise, Astrand suggested that it was probably higher in muscles when only legs were exercised. This assumption was based on the fact that during L exercises, subjects usually complained that their legs refused to continue.

Bergh et al (1976) observed 10 well trained male subjects during the following types of maximal exercise: uphill running, bicycling, arm cranking, and combined arm work and bicycling. The A+L protocol was performed in six different ways, the arms doing 10%, 20%, 30%, or 40% of the total A+L workload; and also with the maximal bicycle work load plus either maximal or submaximal arm work. To ensure a leveling off of $\dot{V}O_2$, two to four maximal workloads were performed for each A+L protocol. Unlike the previous reported results, BLa concentration after maximal

exercise was not significantly different in any of the various types of exercise, in spite of the great variation in work time (3-8 minutes) and exercising muscle mass.

Knowing the differences between upper and lower body exercise lactate responses, these results are questionable. One cannot compare the results of Bergh and coworkers (1976) with those of any other study however, as it is the only one looking at maximal exercise responses in various exercise protocols, performed by highly trained individuals.

It is possible that differences in peak lactate values were undetected due to the sampling times chosen, 2 and 4 minutes post-exercise. Depending on the exercise protocol selected and the nature of the athlete performing the exercise, BL_a may have peaked before or in between these sampling times.

An alternate explanation however might be proposed if one knew what type of athletes were performing the test (i.e., upper body trained, lower body trained, or both upper and lower body trained). Along the same lines, it would be valuable to know the nature of training, whether it was aerobic or anaerobic. This information would assist in explaining the peak lactate values obtained after maximal exercise as one would become more aware of the athlete's capacity for lactate production and lactate removal.

Observations from combined arm plus leg studies have also revealed other interesting trends related to endurance and perceived exertion during the testing sessions. Astrand and Saltin (1961), Bergh et al (1976) and Millerhagen et al (1983) observed that ventilatory anaerobic threshold was significantly delayed in A+L exercise protocols compared to A or L protocols. Treadmill incline sustained in A+L exercise was greater than that sustained in L exercise while oxygen cost per stage of exercise was greater in L exercise as compared to A+L exercise.

With respect to perceived exertion, Astrand and Rodahl (1986), Millerhagen et al (1983), and Mustardi and coworkers (Mustardi, Gandee, & Norris, 1981) all found that subjective perceptions of fatigue were greater during L exercise as compared to A+L exercise.

Results of these investigations suggest that A+L exercise produces less physiological strain than L and, possibly, A exercise. Although this phenomenon has been repeatedly cited in the literature, very few researchers have attempted to explain it and none have designed studies to investigate this phenomenon specifically.

From an ethical standpoint, hesitation to pursue this line of research is understandable. Percutaneous and cardiac catheter insertion are invasive procedures attracting few

willing participants and introducing unwanted sources of error. By studying only one aspect of this phenomenon, peak BLa values for example, these methodological problems could be overcome.

Analysis of whole blood lactate drawn from fingertip samples after various modes of exercise would provide insight into the physiology of A+L exercise and at the same time present few methodological problems. As lactate concentration is higher in whole muscle than in blood at all intensities of exercise (Jacobs & Kaiser, 1982) analysis of whole blood versus serum or plasma lactate would best represent intramuscular lactate levels and peak lactate values associated with maximal exercise. Utilization of the enzymatic amperometric principle of lactate measurement causes lactate containing red blood cells to be centrifuged out of plasma and serum samples, producing lactate values that are lower than those obtained from whole blood analysis (Kontron Medical, 1981).

No studies have been performed on total body endurance trained athletes during maximal exercise efforts and little is known about the peripheral and central training effects on maximal lactate values obtained following A+L or A exercise protocols with respect to athletic performance. This information would be valuable.

Finally, an analysis of BLa values obtained following A+L and A exercise protocols would assist researchers in developing a new explanation for this metabolic phenomenon, an explanation which would focus less on sympathetic activation, and more on the effect of muscle mass and fibre type distribution and recruitment during maximal exercise.

CHAPTER III

Methodology

3.1. Introduction

The purpose of this chapter was to review the methodology used in this study through a description of (a) subjects, (b) experimental protocol and (c) statistical procedures used in the analysis of results.

3.2. Subjects

The subject sample was comprised of male and female national team cross country skiers. Specifically, subjects selected were members of the Men's and Women's Senior and Junior National Cross Country Ski Teams. Data was generated on a total of 13 subjects ranging in age from 17-28 years (Table 2). The athletes represented a lean, upper and lower body trained, high aerobically fit group, with mean maximal oxygen consumption ($\dot{V}O_2$) values ranging from 54.3-78.5 ml/kg/min. From an original sample of 18 skiers, only data on the 13 skiers who successfully completed all test sessions described below was included in the analysis.

Table 2
Mean, Standard Deviation and Range of $\dot{V}O_2$ Values Grouped
According to Team Membership

TEAM DESIGNATION	DESCRIPTIVE STATISTICS	$\dot{V}O_2$ l/min	$\dot{V}O_2$ ml/kg/min	YEARS OF SKI EXPERIENCE*
SENIOR MEN	MEAN	5.45	70.7	12
	STANDARD DEVIATION	0.55	5.31	
	RANGE	4.65-6.31	64.1-78.5	
SENIOR WOMEN	MEAN	3.35	60.7	11
	STANDARD DEVIATION	0.42	6.72	
	RANGE	2.96-4.08	54.3-69.7	
JUNIOR MEN	MEAN	5.37	71.7	7
	STANDARD DEVIATION	0.40	5.92	
	RANGE	4.82-5.90	67.7-77.9	
JUNIOR WOMEN	MEAN	3.08	60.4	8
	STANDARD DEVIATION	0.26	4.11	
	RANGE	2.69-3.41	56.1-64.3	

* YEARS OF SKI EXPERIENCE REPRESENT GROUP MEAN VALUES

Data was collected over a 1 year span at the University of Ottawa during annual testing sessions conducted at the end of May or the beginning of June. Informed consent for testing and statistical evaluation of the data was obtained prior to this testing period by all athletes involved. Regular testing sessions throughout this time period enabled athletes to become familiar with test protocols ensuring results generated represented maximal exercise efforts performed under conditions of maximal motivation.

3.3. Protocol

Data collected during these spring testing sessions represented the start of the athletes' aerobic base training. Various training and competition schedules however prevented all athletes from being tested on exactly the same day. It was not the intent of the study however to evaluate the effects of training and competition on performance during testing sessions. Furthermore, the cross sectional design was not chosen for purposes of comparison of one skier to another. Rather it was hoped that such a design would provide insight into the physiology of A+L simulated ski exercise performed by cross-country skiers, the protocol representing a modified $\dot{V}O_2$ test, a widely implemented test of aerobic fitness .

Testing sessions were conducted in two phases, the difference in the phases being the nature of the $\dot{V}O_2$ test employed. In each phase, the same A only exercise protocol, the rollerboard test, was used. In phase one, the $\dot{V}O_2$ test was administered according to the CASS protocol (Thoden, Wilson, & MacDougall, 1982) modified to incorporate the arm and leg muscles utilized in cross-country skiing (Saar & Schier, 1984). See Appendix A for an illustration. Briefly, the test involved ski walking on a treadmill of increasing grade with simultaneous arm poling movements (through the use of a rope pulley system) until achievement of a heart rate of 180 beats per minute (bpm). Arm pulley resistance was then increased until $\dot{V}O_2$ was achieved (criteria for cessation of tests may be found in Saar & Schier, 1984). Heart rates were recorded using a Polar Electro PE 3000 Sport Tester Heart Rate Monitor (see bibliography) from the beginning to the end of exercise, as well as post exercise until return to a rate of 120 bpm. Fingertip blood samples were collected at 2 minute intervals throughout the test and again at 2 and 3 minutes post exercise.

In phase two, approximately one year later, the A+L protocol two $\dot{V}O_2$ test was performed. Like phase one, the test protocol was incremental in nature yet it was performed on a ski treadmill and was therefore more sports specific (see Appendix B). Using skis and poles, skiers

performed a diagonal stride on a carpeted treadmill whose speed and/or grade changed every 3 minutes until physical exhaustion prevented the skier from continuing. This point usually coincided with an oxygen plateau and maximal heart rates, both of which are characteristic of attainment of $\dot{V}O_2$. Heart rates were again recorded throughout the test using a Sport Tester Heart Rate Monitor which has been proven to be both a valid and stable monitoring tool (Leger & Thivierge, 1988; Karvonen, Chawlbinska-Moneta, & Saynajakangas, 1984). Fingertip blood samples were taken at 3 minute intervals throughout the test and at 0, 1, 2, and 3 minutes post exercise. The increase in the time spent at each workload in the phase two $\dot{V}O_2$ test was implemented as skiers were found to be more efficient in their performance and could tolerate 3 versus 2 minute stages.

Expired gases were collected using a Tissot tank, samples being analyzed at 30 second intervals with a Roxon Medi - Tech oxygen and carbon dioxide analyzer. While expired gases and fingertip blood samples were taken at each stage of the test this information was not pertinent to the present study whose focus was on post exercise PBLa values only. The individual stage $\dot{V}O_2$ and BLa values were incorporated into a second study and these results may be found in Stark (1989).

Blood lactate analysis was conducted using The Kontron Model 640 Lactate Analyzer (Kontron Medical, 1981). Approximately 20 to 60 microlitres (ul) of fingertip whole blood was collected via heparinized capillary tube at each sampling. From this sample 20 ul was withdrawn and immediately added to and mixed with a diluting solution of a set volume (usually 180 ul) contained within special blood haemolysis tubes (Kontron Part 940-0367). This procedure resulted in immediate interruption of glycolysis and liberation of both intracellular and extracellular lactate enabling total lactate content of the blood to be analyzed. While a dilution ratio of 1:10 is usually satisfactory a larger dilution ratio was necessary for lactate concentrations extending beyond 12 mmol/l. Lactate concentration was determined through the enzymatic amperometric principle of measurement, samples drawn being analyzed within 24 hours of the sampling time. It is worthwhile to note however that lactate content of the diluted blood sample remains constant at room temperature for at least 48 hours. For further information on the reliability of the Lactate analyzer 640 see Geysant, Dormois, Barthelemy and Lacour (1985).

Both gas analysis and blood analysis systems were calibrated prior to and throughout the testing sessions, calibration and operational procedures conducted as outlined in the respective operation manuals.

Confirmation of $\dot{M}V\text{O}_2$ was obtained through the utilization of a modified $\dot{M}V\text{O}_2$ protocol. Athletes performed a one stage test of 3 to 5 minutes duration, treadmill incline and speed equalling that attained at the termination of the preceding $\dot{M}V\text{O}_2$ test, or one to two degrees higher depending on the total time spent at the termination load.

The A rollerboard test was designed to assess the capacity of the athlete's anaerobic lactic system, an energy system component linked to the maximal double poling performance required during the finishing stretch of a cross-country ski race.

The rollerboard is a 95 inch inclined track (21.5-26.0 degrees from the floor) which is secured to two vertical posts (see Appendix C). Resting on the board is a trolley upon which the skier kneels. Using pull ropes attached to the vertical posts, the skier pulls himself and the trolley up and down the rollerboard track thereby simulating a double poling action.

The rollerboard test involved the same movements as described above. A tape recorded message provided cues to pull at a cadence of one pull every 2.5 seconds for a duration of 2 minutes. Originally, pulls were performed at a rate of 1 every 3 seconds. With training however, the capacity of the

skiers' anaerobic lactic systems were found to approach the 2 minute time limit of the test and therefore a faster cadence was selected to reflect this improvement. Fingertip lactates were taken at 2 and 3 minutes post exercise.

The rollerboard test was selected as it represented a maximal A exercise effort that incorporated a familiar arm movement pattern. Furthermore, the skiers regularly used this device for upper body training. Further details of the rollerboard test can be found in Saar and Schier (1984).

In summary, the rollerboard test and A+L $\dot{V}O_2$ tests were selected as they represented familiar maximal upper body and maximal combined upper and lower body simulated ski exercises that would generate peak determinable lactic acid levels and provide insight into the physiological response of A+L and A exercise. On all test dates, a minimum of 2 hours rest existed between the completion of one test and the commencement of the second test to allow for a full lactate removal. The rollerboard test always followed the treadmill tests and only one treadmill test was conducted per day. As it was not possible to calculate specific units of work for A and A+L protocols, attempts were made to control for movement pattern, and the effects of work rate, test time and body weight were taken into consideration (Mackenzie, 1989).

3.4 Statistical Analysis

The statistical analysis was performed in four phases. The first phase of analysis involved determination of means and standard deviations of blood lactate concentration obtained from the A and A+L protocols. Means and standard deviations of the Lactate Index (LI) were also determined. The LI was defined as the peak rollerboard blood lactate concentration (PBLa(A)) divided by peak treadmill blood lactate concentration (PBLa(A+L)).

$$LI = \frac{PBLa(A)}{PBLa(A+L)}$$

The LI dependent variable was selected as it represented a relative rather than an absolute measure of a response specific to the upper and lower body endurance trained skiers. The nature of its ratio furthermore rendered it very sensitive to manipulation allowing for a more in depth evaluation of subject responses.

The second phase consisted of a one way analysis of variance using a single factor design with repeated measures (Keppel, 1973). Here the dependent variable was peak blood lactate concentration and the independent

variable was mode of exercise. This phase determined whether significant differences existed in lactate concentration under different exercise conditions among the four populations of skiers .

The third phase of analysis consisted of a two variable factorial design with repeated measures on one factor. Independent variables in this case were mode of exercise and team designation while the dependant variable was LI. This phase examined the nature of the A+L protocols specifically in an attempt to identify unique responses of Senior and Junior Team members.

Phase four consisted of identifying the relationships between the following five dependent variables: PBLa(A), PBLa(A+L), LI, $M\dot{V}O_2$ and total test time (TTT) using a correlational matrix. Correlations were calculated using the Pearson Product Moment Correlation (r) method.

CHAPTER IV

Results

4.1 Introduction.

The purpose of this study was to determine, evaluate, and compare peak fingertip lactates obtained following maximal intensity simulated double poling exercise or A only exercise and, A+L ski striding exercise performed on two different types of treadmills. Furthermore, it was hoped that relationships between whole blood lactate, aerobic fitness indicators, endurance capacity and sports specific training of muscle mass would be identified.

The results will be presented in the following manner .

(a) mean values of A+L $\dot{V}O_2$ and TTT obtained on two testing dates by male and female skiers with a discussion of trends; (b) mean values of PBLa(A) and PBLa(A+L) as well as LI obtained on two testing dates with discussion of trends; (c) correlational table of the following five dependent variables. PBLa(A), PBLa(A+L), LI, $\dot{V}O_2$, TTT and a discussion of findings. A discussion section for significant findings will follow which will include ANOVA tables illustrating the influence of protocol and gender on $\dot{V}O_2$ and the influence of mode of exercise on peak blood lactate (PBLa). The effects of A+L protocol on LI and of mode of exercise and team designation on LI will also be

Table 3

PHASE ONE AND PHASE TWO MEAN MVO_2 (ml/kg/min), TTT (minutes),
PBLa(A), PBLa(A+L) (mmol/l) and LI values

VARIABLE	MEAN +/- S.D.	N	DATE
MV02	72.18 +/- 6.36	13	01/05/85 *
MV02	63.24 +/- 6.58	13	01/06/86 **
TTT	20.00 +/- 3.21	13	01/05/85 *
TTT	20.69 +/- 5.21	13	01/06/86 **
PBLa(A)	8.49 +/- 1.37	13	01/05/85 *
PBLa(A)	9.52 +/- 1.54	13	01/06/86 **
PBLa(A+L)	6.98 +/- 1.93	13	01/05/85 *
PBLa(A+L)	9.25 +/- 1.55	13	01/06/86 **
LI	1.30 +/- .039	13	01/05/85 *
LI	1.06 +/- 0.26	13	01/06/86 **

Table 4

MEAN MVO_2 AND TTT VALUES FROM TWO DIFFERENT A+L PROTOCOLS FOR
MALE AND FEMALE SUBJECTS

GENDER	DATE	N	MVO_2 +/- S.D. (ml/kg/min)	TTT +/- S.D. (minutes)
MALE	01/05/85 *	8	76.59 +/- 1.75	20.31 +/- 3.88
FEMALE	01/05/85 *	5	65.14 +/- 3.87	19.50 +/- 2.00
MALE	01/06/86 **	8	67.76 +/- 3.50	21.81 +/- 5.48
FEMALE	01/06/86 **	5	56.00 +/- 1.41	18.90 +/- 4.72

* TREADMILL PROTOCOL ONE

** TREADMILL PROTOCOL TWO

addressed.

As illustrated in Table 3, treadmill $\dot{V}O_2$ values were 12% higher when skiers performed the A+L exercise using the ski striding / rope pulley technique than when the A+L ski treadmill exercise was performed. On both test dates male $\dot{V}O_2$'s were on average 16% higher than female $\dot{V}O_2$'s (Table 4). Both treadmill protocol and gender differences later proved to be statistically significant (see discussion section).

Tables 3 and 4 also illustrate TTT means and standard deviations grouped according to treadmill protocol and gender. In all instances, no statistical significance was found.

With respect to PBLa, A mean values were higher than A+L values over two test dates (Table 3). Differences however were greater between A and A+L protocol one (Table 3). A one way ANOVA revealed that mode of exercise did produce statistically significant differences in PBLa values. More specifically, Tukey's test identified significant differences between protocol one PBLa(A) and PBLa(A+L), and between protocol one and two PBLa(A+L), but not between protocol two PBLa(A) and PBLa(A+L) values. With respect to PBLa(A), values were higher on the second test date but differences were not statistically significant. The

physiological relevance of these findings will be addressed in the discussion section.

With respect to LI, mean values were higher on test date one than on test date two (Table 3). LI is the ratio of PBLa(A), divided by PBLa(A+L) . Lower values on date two then reflect the increase in PBLa(A+L) values previously discussed. A one way ANOVA was run to determine significance between these LI means. Although the difference between these means was not statistically significant it was equivalent to 90% of the difference required for statistical significance.

The correlational matrix in Table 5 presents the Pearson Correlational Coefficients for the variables LI, PBLa(A), PBLa(A+L), $\dot{M}V\text{O}_2$ and TTT taken as pairs. A strong negative correlation (-0.83) was noted between PBLa(A+L) and LI illustrating that the decreasing LI ratio is a function of the increasing PBLa(A+L) denominator. Most surprising however is the lack of a high correlation between the remaining variables. High PBLa(A) values do not imply high values for PBLa(A+L). PBLa(A+L) does not represent the additive effect of A and L lactate production. The addition of leg exercise to arm exercise does seem to change the nature of the physiological lactate response.

Low correlation between the variable pair $\dot{M}V\text{O}_2$ and LI

also deserves attention. LI, a relative measure of an athlete's lactate response to A versus A+L exercise is not necessarily related to their maximal oxygen consumption

Table 5

CORRELATIONAL MATRIX PRESENTING THE PEARSON CORRELATION COEFFICIENTS FOR LI, PBLa(A), PBLa(A+L), MVO₂ AND TTT TAKEN AS PAIRS

N=26	LI	PBLa(A)	PBLa(A+L)	MVO ₂	TTT
	mmol/l	mmol/l	ml/kg/min	min	
LI	1.00	0.25	-0.83*	0.19	0.10
PBLa(A)	0.25	1.00	0.25	0.02	0.27
PBLa(A+L)	-0.83*	0.25	1.00	-0.09	0.00
MVO ₂	0.19	0.02	-0.09	1.00	0.19
TTT	0.10	0.27	0.00	0.19	1.00

* significant at $p < .0001$

ability. This could imply that oxygen consumption is not a related factor in this form of A and A+L exercise. Perhaps an athlete's individual ability to tax a larger percentage of their MVO₂ is what distinguishes their lactate oxidizing capacity. For example, mitochondrial size, number and enzyme levels, vascular bed size, SO fibre percentage and size and ultimately, arteriovenous oxygen differences could all be factors that might better dictate an athletes lactate

oxidizing capacity (Holloszy & Coyle, 1984).

TTT is another variable that one might have thought would be positively correlated with $\dot{M}V\dot{O}_2$. If oxygen consumption is not a related factor than TTT may too be more a function of local muscular characteristics resulting from the peripheral versus central changes induced by upper and lower body endurance training. Another possibility is that TTT may be indicative of the degree to which an athlete can tolerate lactate, can psychologically motivate themselves or, is mechanically efficient in performing the exercise task (Asmussen & Mazin, 1987a, 1987b; Franklin, 1985).

Lack of correlation amongst these five dependant variables may exist for a variety of reasons. The significance of this however lies in the fact that these variables are truly independant of one another and represent distinct physiological responses.

4.2. Discussion.

The fact that A+L MVO_2 values of male team members were significantly higher than female team members coincides with the exercise physiology literature (Astrand & Rohdal, 1970) and is understood to be a result of the higher fat body mass and lower oxygen-binding capacity of the blood of the human female. A quite unexpected finding

Table 6

MVO_2 AS A FUNCTION OF A+L PROTOCOL AND GENDER.

A X (B X S) DESIGN

A = GENDER

B = PROTOCOL

SOURCE	SUM OF SQUARES	df	MEAN SQUARE	F RATIO
A	828.77	1	828.77	86.25*
S/A	69.65	11	6.33	
B	520.22	1	520.22	54.14*
A X B	0.15	1	0.15	0.02
B X SA	105.69	11	9.61	

* SIGNIFICANT AT THE $p < 0.05$ LEVEL

however was the fact that MVO_2 values significantly decreased from one testing session to the next. This was true of both pooled subject data as well as separate male and female group data. One possible explanation is that

training throughout the year between testing sessions could have influenced the MVO_2 values. It seems unlikely though that the training regime of an endurance athlete would produce a decline rather than an increase in MVO_2 values, and consistently affect MVO_2 values of every team member.

The second more plausible explanation for declining MVO_2 values would be the difference in treadmill protocols between the first and second test session. The second A+L protocol represented a much more sports specific exercise simulating the upper and lower body limb movement characteristic of the diagonal stride technique in cross-country skiing. It is possible that the familiarity of this movement pattern enabled the subjects to exert themselves to a greater degree and more closely mimic the muscle involvement and work intensity that might be encountered during a race of the same speed and grade. Increased intensity, higher BLa levels, and longer treadmill stages may all have been factors influencing MVO_2 values. If oxygen consumption is not a limiting factor in this form of A+L exercise, one would not expect the decline in MVO_2 values to influence TTT. As previously discussed no significant difference was noted between the TTT's of both A+L protocols. Finally, increased exercise intensity would be reflected in higher $PBLa$ values post exercise and as noted in Table 8 this was the case. Protocol two $PBLa$ values were

significantly higher than PBLa's of protocol one possibly indicating greater recruitment of FG fibre.

As absolute work was not measured during the performance of either phase one or phase two (A+L) protocol, it is possible that the differences between $\dot{M}V\text{O}_2$ and PBLa(A+L) values obtained could be accounted for on the basis of work done and efficiency of technique. It is possible for example that work efficiency was lower or real work was higher in phase one versus phase two (A+L) protocol. Distribution of work between upper and lower body may also have been quite different in each protocol. Perhaps the use of the rope pulley system in (A+L) protocol one permitted a degree of support for the skiers not present in (A+L) protocol two. Perhaps the treadmill angle sustained and the work required to lift the legs on (A+L) protocol one was greater than that encountered in (A+L) protocol two. In either case, if percentage of work done by upper and lower body was different in each protocol, so was the work intensity relative to that mass of upper or lower body muscle. Similarly percentage of FG and SO fibre recruited and peak muscle and blood lactate would also vary. On the basis of this information then one can propose that the differences in $\dot{M}V\text{O}_2$ and PBLa(A+L) values noted between both (A+L) protocols may be better explained by the nature of the A+L protocol rather than by physiological changes incurred as a result of training regimes.

Table 7

PEAK BLOOD LACTATE AS A FUNCTION OF MODE OF EXERCISE

SOURCE	SUM OF SQUARES	df	MEAN SQUARE	F RATIO
MODE OF EXERCISE	43.77	2	21.88	8.17*
ERROR	131.24	49	2.68	

* SIGNIFICANT AT THE $p < 0.05$ LEVEL

Table 8TUKEY'S STUDENTIZED RANGE HONESTLY SIGNIFICANT DIFFERENCE (HSD)
TEST FOR THE VARIABLE : PEAK BLOOD LACTATE

ALPHA = 0.05 CONFIDENCE = 0.95 DF=49 MSE=2.67833
CRITICAL VALUE OF THE STUDENTIZED RANGE = 3.418

MODE OF EXERCISE COMPARISON	SIMULTANEOUS LOWER CONFIDENCE LIMIT	DIFFERENCE BETWEEN MEANS	SIMULTANEOUS UPPER CONFIDENCE LIMIT
3 AND 1	-1.10	0.24	1.59
3 AND 2	0.72	2.27	3.82 *
1 AND 3	-1.59	-0.24	1.10
1 AND 2	0.68	2.02	3.37 *
2 AND 3	-3.82	-2.27	-0.72 *
2 AND 1	-3.37	-2.02	-0.68 *

COMPARISONS SIGNIFICANT AT THE $p < 0.05$ LEVEL ARE INDICATED BY *
MODE 1 = A MODE 2 = A+L PROTOCOL #1 MODE 3 = A+L PROTOCOL #2

As stated in the previous section, mode of exercise was found to produce significant differences in PBLa means (see Table 7). The results of Tukey's test (Table 8) revealed that PBLa(A) values were higher than PBLa(A+L) of both protocols but only significantly higher than A+L protocol one lactates. As PBLa(A) were not significantly different over the two test dates, lack of significance between PBLa(A) and PBLa(A+L) protocol two lactates were a result of increases in the PBLa(A+L) values.

As the nature of the testing protocol may be influential in the determination of physiological responses, it is possible that an examination and comparison of the testing protocols could provide an explanation for the higher PBLa(A) values obtained.

The nature of the upper body movement employed in each protocol for example is one area which warrants closer consideration. It is possible that the A protocol may incorporate a greater isometric component than the A+L protocol. With respect to the A exercise, there is a greater degree of upper body stabilization required for maintenance of balance due to the absence of the postural weight bearing lower limbs. The ratio of time upper body muscles spend in contraction versus relaxation may also be longer in the A protocol. The arms must first pull the body up, and then lower it down the rollerboard track involving both

concentric and eccentric contractions (Sale & Norman, 1982). As an increase in contraction length will lead to an increase in venous pressure and a subsequent decrease in perfusion pressure, blood flow may be limited (Clausen, 1973). This in combination with the fact that upper body musculature may have a higher ratio of FG to SO fiber and thus a lower oxidative capacity than lower body musculature could suggest a higher dependence on an anaerobic production of energy and a decrease in lactate uptake. This could lead to higher intramuscular and blood lactate values.

The arm position in the A protocol may also contribute to increased lactate values as the arm pull begins and ends in an arms overhead position. The elevated arms position could produce a decrease in the hydrostatic pressure that might not be offset by the increase in systemic blood pressure characteristic of A exercise. This too could lead to compromised blood flow.

Finally, the vascularity of FG fibre in general may also increase BLA values in the A protocol. In comparison to SO fibre, the relatively fewer arterioles and capillaries increase resistance to outflow of blood from the artery limiting perfusion of the working muscle.

While blood flow may be compromised in A exercise it is

not necessarily limiting. Vasoconstriction in the non-exercising legs represents a pronounced elevation in peripheral resistance due to the size of its vascular bed. Blood pressure will increase to maintain adequate blood flow. Due to the inactivity of the leg muscles there will be little build up of vasodilating metabolites to counteract the sympathetic induced vasoconstriction. Maximal effort by upper limbs on the other hand will ensure maximal dilatation of upper limb resistance vessels.

As blood flow was not measured one can only speculate as to its role in muscle metabolism in this study. A great deal of the information about maximal blood flow stems from in situ electrical stimulation experiments which are thought to underestimate in vivo blood flow values (Laughlin and Armstrong, 1985). True venous pressures within skeletal muscle vasculature are also unknown making calculations of the pressure difference across the vascular bed impossible. Conclusions based on blood flow and pressure then would be premature and purely theoretical.

To what extent the above factors influence PBLa(A) values cannot be determined. One must realize however that similar variables will affect the A+L exercise and potentially cause an increase in A+L lactate production. In the A+L protocols, the upper body musculature definitely performs a stabilizing function adding power to and

balancing the lower body stride. In protocol two especially, arms take on a weight bearing role to accommodate increases in treadmill grade and postural forward lean. As well, subjects are required to hold and manipulate ski poles increasing the amount of time the arms are in a state of contraction. The closeness of this upper body exercise simulation (relative to the arm pulley system) to actual cross-country arm technique furthermore, encourages greater and more natural participation of upper body accessory muscles which could promote a regular breathing pattern. This would be quite unlike the breathing pattern accompanying the arm movement incorporated in the rollerboard test, subjects tending to hold their breath throughout the duration of each pull. Finally, the hinderance of the oxygen monitoring system not present in the A protocol may also affect subject breathing. Mouthpieces, air collection tubing and stabilizing head gear utilized in protocol two, could have made subjects more apprehensive during the A+L tests than during the A exercise. All of these factors then could have contributed to elevated lactate levels in the A+L exercise condition.

The physiology of A exercise is truly distinct from A+L exercise. It is well documented that at a given relative or absolute submaximal load A exercise is performed at a greater physiological cost than L and A+L exercise. Studies of A exercise at maximal loads however all indicate that

peak lactate values are less than that achieved in L and A+L maximal exercise (Secher et al, 1974 ; Secher, 1977; Bergh et al, 1976; Vokac et al, 1975, Astrand et al, 1965). These results are contradictory to what this study has found. While variables such as blood flow, type and length of contraction and efficiency of technique may have influenced lactate levels in this study, so have they influenced previous research. Although their role in lactate metabolism cannot be ignored, it is doubtful that they can account for the total reversal of the A lactate trend sited in this study and alternative explanations must be sought.

It is possible that the lactate sampling site could have influenced the PBLa(A) values. The fingertip site used for blood collection would produce a falsely high PBLa(A) level due to the fact that the sample was peripheral and had not been adequately diluted by the systemic circulation. If this was the case then PBLa(A+L) values would also have been falsely high, the sampling site being the same in both A and A+L exercise.

Although sampling sites were identical in both A and A+L protocols, their proximity to the contracting muscle mass may not necessarily have been the same. Temperature induced changes in post exercise blood redistribution may have also influenced PBLa values obtained. Similarly, peak lactate values measured were assumed to be representative

of maximal values but as work was not actually measured this may not have been the case. While all these factors may have influenced PBLa(A) and PBLa(A+L) values, skiers did perform to their voluntary limit in both A and A+L protocols and lower PBLa(A+L) values cannot be explained by skiers attempts to avoid maximal exertion or to "hold back."

The uniqueness of this work in comparison to previous research is that our subjects are a high aerobically fit group who have undergone both upper and lower body endurance training for a minimum of 7 to a maximum of 12 years. In addition, they are performing maximal intensity exercise which is very specific to the sport for which they were trained. The most plausible explanation for the elevated PBLa(A) levels then should take into account the above factors.

In UT subjects it has been shown that resting legs are more effective lactate eliminators than resting arms and that A+L exercise can produce a positive arteriovenous lactate difference over working legs not found in A and L exercise conditions (Freyschuss & Strandell, 1967; Green et al, 1979). Mere postural differences can lead to achievement of a 13% higher workload when arms are working in a standing versus a sitting position (Vokac et al , 1975). T individuals can sustain a greater treadmill incline for a longer time and perceive less fatigue in A+L versus A and L

exercise (Millerhagen et al, 1983). Knowing how endurance training enhances the oxidative potential of both FG and SO fibre and thus the peripheral as well as central training adaptations sustained by the cross-country skiers, a metabolic process whereby A+L exercise could enhance lactate uptake and reduce peak blood lactate levels below that found in A exercise can be suggested. The addition of leg to arm exercise would lead to an increase in venous return due to the activity of the muscle pump propelling the blood back toward the heart. A decrease in the blood volume of the legs would lead to a decrease in venous pressure which in combination with an increased hydrostatic pressure would lead to an improved cardiac output and perfusion of the muscle bed. Blood flow would be redistributed allowing a widening of the arteriovenous oxygen difference and the potential for a greater extraction of oxygen. As prolonged heavy exercise can lead to increased utilization of blood borne lactate (Karlsson, 1971), increases in lactate production by upper and lower limbs in the A+L exercise would be compensated by improved lactate absorption. The highly oxidative lower limb muscle mass would promote lactate diffusion due to the larger fibre surface area and capillary to fibre ratio. Good blood lactate removal by SO fibre would increase the rate of release of intramuscular FG lactate and decrease the subjective feeling of exertion that accompanies high intramuscular lactate levels (Astrand & Rodahl, 1986; Millerhagen et al,

1983, Mustardi et al, 1981).

While A+L exercise would produce the above metabolic response, endurance training, particularly sports specific would enhance the process. The characteristic increase in mitochondrial size, number and enzyme levels, in LDH-H, in fibre capillary density and in SO fibre surface area, would lower the PBLa(A+L) values below PBLa(A) values. If UT individuals require higher blood lactates to obtain the same lactate removal (Donovan & Brooks, 1983) than T subjects would begin lactate removal at an earlier point in the exercise bout. With a linear relationship existing between $\dot{V}O_2$ and lactate turnover (Mazzeo et al, 1986) T subjects would tend to demonstrate a higher rate of turnover than UT subjects. Improved lactate uptake would lead to a higher maximal rate of lactate release (Pendergast, Cerretelli, & Rennie, 1979) and an improved exercise tolerance.

Pendergast and colleagues (1979) illustrated that maximal A exercise in both T and UT individuals produced no significant differences in PBLa concentrations. In this study no significant differences were found between the first and second test date PBLa(A) values. This supports the theory then that the PBLa(A+L) values of the cross-country skiers are probably a function of their endurance trained, highly oxidative lower body mass reducing PBLa values. The lower A+L values and the attainment of significant

differences between PLBa(A) and PBLa(A+L) means represent a reduction in PBLa values rather than an increase in their PBLa(A) values.

With respect to LI, lower values on test date two reflected increases in PBLa(A+L) as opposed to decreases in PBLa(A) values. The difference between test date means was almost significant ($p < 0.05$) and may have achieved true significance with a greater number of subjects. The implication that a significant difference reflects an improvement in the athletes lactate oxidizing capacity however must be made with caution. As the degree of sports specificity in A+L exercise protocols produced significant differences in both MVO_2 and PBLa values, it is reasonable to assume that the LI values were similarly affected. It would be necessary then to first examine the change in LI values over a year using the same A+L protocol before the LI of alternate protocols could be compared and its relevance as a physiological measurement determined.

Treadmill protocol and team designation produced no significant differences in LI means. Knowing that the sports specificity of exercise simulations and subject gender can influence the response of physiological parameters such as PBLa and MVO_2 , perhaps comparisons of LI values produced using the same A+L protocol on a greater subject pool would improve significance.

The results of this study indicate that peak fingertip whole blood lactate values obtained following maximal intensity simulated double poling or arms only exercise, significantly exceeded those obtained following maximal intensity ski-striding or combined arms and leg exercise when performed by the Canadian National Cross Country Team according to the modified C.A.S.S. protocol (Saar and Schier, 1984). Performance of a maximal intensity diagonal ski stride on a carpeted ski treadmill with skis and poles, a more sports specific A+L exercise, increased peak fingertip whole blood lactate values beyond those found in the modified C.A.S.S. protocol. Although lactate values were still below those achieved in the A exercise, differences were not significant. The lower PBLa values obtained in the A+L exercise seemed to be a function of the addition of active lower body muscle mass to upper body exercise and more specifically, the lactate oxidizing capacity of the skiers' endurance trained SO fibre.

Differences in PBLa(A+L) values seemed to be a function of the degree of sports specificity of the A+L protocol to cross-country skiing. It is possible that ski-striding performances on the ski treadmill represented a more sports specific and familiar movement pattern enabling skiers to involve a greater proportion of muscle mass and achieve higher PBLa levels through increased recruitment of FG fibre.

Finally, this study found no statistically significant correlations between any pair of the following variables: PBLa(A), PBLa(A+L), MVO_2 , TTT and LI, notwithstanding the strong negative correlation between LI and PBLa(A+L), (see Table 11). This lack of significance could suggest that these variables are truly independent of one another and represent distinct physiological responses.

Chapter V

Conclusions And Recommendations

5.1. Introduction.

The purpose of this study was to determine, evaluate and compare peak fingertip lactates obtained following maximal intensity simulated double poling exercise A exercise and, A+L ski striding exercise performed on two different types of treadmills. If moderately high to high endurance trained cross-country skiers may be characterized by good lactate removal, it was thought that PBLa(A) values would be higher than PBLa(A+L) values.

5.2 Conclusions:

Contradictory to previous research findings, the conclusions of this study support the aforementioned hypothesis.

1. Mean PBLa(A) values were greater than mean PBLa(A+L) values.
2. Significant differences ($p < 0.05$) were found between PBLa(A) and protocol one PBLa(A+L), but not between

PBLa(A) and protocol two PBLa(A+L).

3. Protocol one A+L exercise elicited significantly higher ($p < 0.05$) MVO_2 values and significantly lower ($p < 0.05$) PBLa values than protocol two A+L exercise.
4. No statistically significant correlations were found between PBLa(A), PBLa(A+L) and MVO_2 .
5. No statistically significant correlations were found between PBLa(A), PBLa(A+L) and TTT.

As research to date has always found A exercise PBLa values to be less than A+L exercise PBLa values, the results of this study may be attributed to the nature of the endurance trained subjects studied as well as the protocols selected. The Canadian National Cross Country Team represented an upper and lower body endurance trained group of high aerobic fitness who were participating in exercise simulations that closely resembled the manner in which they regularly trained. The incorporation of their highly oxidative lower body mass in a sports specific A+L simulation enabled them to maximally produce and oxidize lactate and lower their PBLa(A+L) values below PBLa(A) values.

5.3. Recommendations:

While these conclusions are unique they are very specific to high aerobically trained cross-country skiers and shouldn't be generalized to all sports that combine arm and leg exercise. It must be remembered furthermore, that peak blood lactate is the product of the rate of lactate production, diffusion and removal. The fingertip samples used in this study therefore represent net values whose metabolic origin can only be theoretically determined.

If this study is to be duplicated it is recommended that a larger group of male and female subjects be tested to establish reliability of results. LI values should be calculated for only one A+L protocol and compared over time so that the usefulness of this relative measurement can be determined.

The comparison of A+L exercise protocols in this study reinforce how the degree of sports specificity can influence physiological responses. Both the nature of the movement performed, as well as the physiological demands of the sport in conjunction with the individual athlete profiles must be examined if the relationships between physiological variables are to be identified. While improving sports specificity may in the short term decrease generalizability of results, it is a necessity for long term advancement of

the sport physiology field.

Bibliography

Anderson, P. CAPILLARY DENSITY IN SKELETAL MUSCLE OF MAN. Acta Physiol. Scand., 95: 203-205, 1975.

Ariano, M. A., Armstrong, R. B., & Edgerton, V. R. HIND LIMB MUSCLE FIBER POPULATIONS OF FIVE MAMMALS. J. Histochem. Cytochem., 21:51-55, 1973.

Asmussen, E. & Mazin, B. A CENTRAL NERVOUS COMPONENT IN LOCAL MUSCULAR FATIGUE. Eur. J. Appl. Physiol., 38: 9-15, 1978a.

Asmussen, E. & Mazin, B. RECUPERATION AFTER MUSCULAR FATIGUE BY "DIVERTING ACTIVITIES". Eur. J. Appl. Physiol., 38: 1-8, 1978b.

Asmussen, E., & Nielsen, M. REGULATION OF BODY TEMPERATURE DURING WORK PERFORMED WITH ARMS AND LEGS. Acta Physiol. Scand., 14: 373-382, 1947.

Astrand, P.O., Ekblom, B., Messin, R., Saltin, B., & Stenberg, J. INTRA-ARTERIAL BLOOD PRESSURE DURING EXERCISE WITH DIFFERENT MUSCLE GROUPS. J. Appl. Physiol., 20: 253- 1965.

Astrand, P.O., & Rodahl, K. TEXT BOOK OF WORK PHYSIOLOGY. New York : McGraw-Hill, 279, 1970.

Astrand, P.O., & Rodahl, K. TEXT BOOK OF WORK PHYSIOLOGY. New York : McGraw, 1986.

Astrand, P.O., & Saltin, B. MAXIMAL O₂ UPTAKE AND HEART RATE IN VARIOUS TYPES OF MUSCULAR ACTIVITY. J. Appl. Physiol., 16: 977-981, 1961.

Bass, A., Brdiczka, D., Eyer, P., Hofer, S., & Pette, D. METABOLIC DIFFERENTIATION OF DISTINCT MUSCLE TYPES AT THE LEVEL OF ENZYMATIC ORGANIZATION. Eur. J. Biochem., 10:198-206, 1969.

Belanger, A. Y., & McComas, A. J. A COMPARISON OF CONTRACTILE PROPERTIES IN HUMAN ARM AND LEG MUSCLES. Eur. J. Appl. Physiol., 54: 326-330, 1985.

Bergh, J., Kanstrup, L., & Ekblom, B. MAXIMAL OXYGEN UPTAKE DURING EXERCISE WITH VARIOUS COMBINATIONS OF ARM AND LEG WORK. J. Appl. Physiol., 41:191-196, 1976.

Bevegard, S., Freyschuss, U., & Strandell, T. CIRCULATORY ADAPTATION TO ARM AND LEG EXERCISE IN SUPINE AND SITTING POSITION. J. Appl. Physiol., 21:37-46, 1966.

Bobbert, A.C. PHYSIOLOGICAL COMPARISON OF THREE TYPES OF ERGOMETRY. J. Appl. Physiol., 15: 1007-1014, 1960.

Brooke, M. H., & Kaiser, K. K. MUSCLE FIBRE TYPES: HOW MANY AND WHAT KIND?. Arch. Neurol., 23: 369-379, 1970

Brooks, G. A. ANAEROBIC THRESHOLD: REVIEW OF THE CONCEPT AND DIRECTIONS FOR FUTURE USE. Med. Sci. Sports Ex., 17(1): 22-31, 1985a.

Brooks, G.A. LACTATE : GLYCOLYTIC PRODUCT AND OXIDATIVE SUBSTRATE DURING EXERCISE IN MAMMALS-"THE LACTATE SHUTTLE". In Comparative Physiology And Biochemistry -Current Topics And Trends Vol .A. Respiration -Metabolism -Circulation. R. Gilles (ed) 208-218, Springer-Verlag : Berlin, 1985b.

Brooks, G.A. THE LACTATE SHUTTLE DURING EXERCISE AND RECOVERY. Med. Sci. Sports. Exercise. 18(3): 360-368, 1986.

Brooks, G. A., & Donovan, C. M. EFFECT OF ENDURANCE TRAINING ON GLUCOSE KINETICS DURING EXERCISE. Am. J. Physiol. Endocrinol. Metab. 7, (E505-E512), 1983.

Buchthal, F. & Schmalbruch H. CONTRACTION TIMES AND FIBRE TYPES IN INTACT HUMAN MUSCLE. Acta. Physiol. Scand., 79: 435-452, 1970.

Burke R. E., & Edgerton, J. R. MOTOR UNIT PROPERTIES AND SELECTIVE INVOLVEMENT IN MOVEMENT. in J.H. Wilmore & J.E. Keogh (Eds) Ex. Sports Sci. Rev. Vol 3, Academic Press, New York 31-81, 1975.

Carleston, A., Hallgren, B., Jagenburg, R., Svanborg, A., & Werko, L. MYOCARDIAL METABOLISM OF GLUCOSE, LACTIC ACID, AMINO ACIDS AND FATTY ACIDS IN HEALTHY HUMAN INDIVIDUALS AT REST AND AT DIFFERENT WORKLOADS. Scand. J. Clin. Lab. Invest., 13: 418-428, 1961.

Clausen, J. P. MUSCLE BLOOD FLOW DURING EXERCISE AND ITS SIGNIFICANCE FOR MAXIMAL PERFORMANCE. Limiting Factors of Physical Performance : International Symposium, J.Keul (ed) Georg Thieme Publishers, Stuttgart : 253 - 266, 1973.

Clausen, J.P., Klausen, K., Rasmussen, B., & Trap-Jensen, J. EFFECTS OF SELECTIVE ARM & LEG TRAINING ON CARDIAC OUTPUT AND REGIONAL BLOOD FLOW. Acta. Physiol. Scand., 82: 35-36A, 1971a.

Clausen, J. P., Klausen, K., Rasmussen, B., & Trap-Jensen J. EFFECT OF STRENUOUS ARM AND LEG TRAINING ON PULMONARY VENTILATION, METABOLISM AND BLOOD PH DURING SUBMAXIMAL EXERCISE. Acta. Physiol. Scand., 83: 8A, D8, 1971b.

Clausen, J.P., Klausen, K., Rasmussen, B., & Trap-Jensen, J. CENTRAL AND PERIPHERAL CIRCULATORY CHANGES AFTER TRAINING OF THE ARMS OR THE LEGS. Am. J. Physiol., 225: 675-682, 1973.

Connett, R. J., Gayeski, T. E. J., & Honig, L. R. LACTATE ACCUMULATION IN FULLY AEROBIC WORKING DOG GASTRIC MUSCLE. Am. J. Physiol., 246: H120-H128, 1984.

Davis, J.A., Vodak, P., Wilmore J.H., Vodak, J., & Kurtz, P. ANAEROBIC THRESHOLD AND MAXIMAL AEROBIC POWER FOR THREE MODES OF EXERCISE. J. Appl. Physiol., 41: 544-550, 1976.

Depocas, F., Minaire, Y., & Chattonnet, J. RATES OF FORMATION AND OXIDATION OF LACTIC ACID IN DOGS AT REST AND DURING MODERATE EXERCISE. Can. J. Physiol. Pharmacol., 47: 603-610, 1969.

Donovan, C.M., & Brooks, G.A. ENDURANCE TRAINING AFFECTS LACTATE CLEARANCE, NOT LACTATE PRODUCTION. Am. J. Physiol., 224: E83-E92, 1983.

Edgerton, V.R. , & Simpson, D.R. THE INTERMEDIATE FIBRE OF RATS AND GUINEA PIGS. J. of Histochem. Cytochem., 17: 828-38, 1969.

Edgerton, V.R., Smith, J.L., & Simpson, D.R. MUSCLE POPULATIONS OF HUMAN LEG MUSCLES. Histochem. J., 7:259-266, 1975.

Edstrom, L. , & Nystrom, B. HISTOCHEMICAL TYPES AND SIZES OF FIBRES IN NORMAL HUMAN MUSCLES. A BIOPSY STUDY. Acta Neurol. Scand., 45: 257-69, 1969.

Elder, G.C.B., Bradenbury, K., & Roberts, R. VARIABILITY OF FIBRE TYPE DISTRIBUTION WITHIN HUMAN MUSCLES. J. Appl. Physiol: Resp. Environ. Ex. Physiol., 53:1473-1480, 1982.

Eldridge, F.L. RELATIONSHIP BETWEEN TURNOVER AND BLOOD CONCENTRATION IN EXERCISING DOGS. J. Appl. Physiol., 39: 231-234, 1975.

Eldridge, F.L., Tso, L., & Chang, H. THE RELATIONSHIP BETWEEN TURNOVER RATE AND BLOOD CONCENTRATION OF LACTATE IN NORMAL DOGS. J. Appl. Physiol., 37: 316-320, 1974.

England, P., Powers, S.K., Dodd, S., Caulender, T., & Brooks, E. THE EFFECT OF ACUTE THERMAL DEHYDRATION ON BLOOD LACTATE ACCUMULATION DURING INCREMENTAL EXERCISE. J. Sports Sci., 2:105-111, 1984.

Essen, B. GLYCOGEN DEPLETION OF DIFFERENT FIBRE TYPES IN HUMAN SKELETAL MUSCLE DURING INTERMITTENT AND CONTINUOUS EXERCISE. Acta. Physiol. Scand., 103: 446-45 1978a.

Essen, B. STUDIES ON THE REGULATION OF METABOLISM IN HUMAN SKELETAL MUSCLE USING INTERMITTENT EXERCISE AS AN EXPERIMENTAL MODEL. Acta. Physiol. Scand. Suppl., 454, 1978b.

Essen, B., Pernow, B., Gollnick, P.D., & Saltin, B. MUSCLE GLYCOGEN CONTENT AND LACTATE UPTAKE IN EXERCISING MUSCLES", in H. Howard and J.R. Portsmans (Eds.) Metabolic Adaption To Prolonged Physical Exercise. Proceedings of the Second Internatn'l Symposium on Biochemistry of Exercise. Basel: Birkhauser-Verlag, 1973.

Fardy, P.S., Webb, D., & Hellerstein H.K. BENEFITS OF ARM EXERCISE IN CARDIAC REHABILITATION. Physician and Sportsmedicine, 5: 30-41, 1977.

Foster, D.W. FROM GLYCOGEN TO KEYTONES-AND BACK. Diabetes, 33: 1188-1199, 1984.

Fox, E.L., & Mathews, D.K. EXERCISE AND TRAINING IN FEMALES. In The Physiological Basis Of Physical Education and Athletics. J. Butler, M. Miller, & P. Estes. (ed), Philadelphia, Saunders College Publishing, 347-384, 1981.

Franklin, B.A. EXERCISE TESTING, TRAINING AND ARM ERGOMETRY. Sports Medicine, 2:100-119, 1985.

Franklin, B.A., Vander, L., Wisley, D., & Rubinfire, M. AEROBIC REQUIREMENTS OF ARM ERGOMETRY: IMPLICATIONS FOR EXERCISE TESTING AND TRAINING Physician and Sportsmedicine, 11: 81-90,1983.

Freminet, A., Poyart, C., Bursaux, E., & Tablon, T. EFFECTS OF PHYSICAL TRAINING ON THE RATES OF LACTATE TURNOVER AND OXIDATION IN RATS. In Metabolic Adaption To Prolonged Physical Exercise, H. Howald & J.R. Portsman (ed), Basel, Birkhauser,113-118, 1975.

Freyschuss, U., & Strandell, T. LIMB CIRCULATION DURING ARM AND LEG EXERCISE IN SUPINE POSITION. J. Appl. Physiol., 23(2):163-170,1967.

Gaesser, G.A., & Rich, R.G. INFLUENCE OF CAFFEINE ON BLOOD LACTATE RESPONSE DURING INCREMENTAL EXERCISE. Int. J. Sports Med., 6(4):207-211, 1985.

Gertz, E.W., Wisneski, J.A., Neese, R., Bristo, J.D., Searle, G.L., & Hanlon, J. T. MYOCARDIAL LACTATE METABOLISM: EVIDENCE OF LACTATE RELEASE DURING NET CHEMICAL EXTRACTION IN MAN. Circulation, 1273-1279, 1981.

Geyssant, A., Dormois, D., Barthelemy, J.C., & Lacour, J.R. LACTATE DETERMINATION WITH THE LACTATE ANALYSER LA 640: A CRITICAL STUDY Scand. J. Clin. Invest. 45:145-149,1985.

Gleser, M.A. EFFECTS OF HYPOXIA AND PHYSICAL TRAINING ON HEMODYNAMIC ADJUSTMENTS TO ONE-LEGGED EXERCISE. J. Appl. Physiol., 655-659, 1973.

Gollnick, P.D., Armstrong, R.B., Saubert, C.W., Piehl, K., & Saltin B. ENZYME ACTIVITY AND FIBRE COMPOSITION IN SKELETAL MUSCLE OF UNTRAINED AND TRAINED MEN. J. Appl. Physiol.,33: 312-319, 1972.

Gollnick, P.D., Armstrong, R.B., Sembrowich, W.L., Shepard, R.E., & Saltin B. GLYCOGEN DEPLETION PATTERN IN HUMAN SKELETAL MUSCLE FIBRES AFTER HEAVY EXERCISE. J. Appl. Physiol., 34: 615-618, 1973.

Gollnick, P.D., Karlsson J., Piehl, K., & Saltin, B. SELECTIVE GLYCOGEN DEPLETION IN SKELETAL MUSCLE FIBRES OF MAN FOLLOWING SUSTAINED CONTRACTIONS. J. Appl. Physiol., 241: 59-67, 1974a.

Gollnick, P.D., & Matoba, H. THE MUSCLE FIBRE COMPOSITION OF SKELETAL MUSCLE AS A PREDICTOR OF ATHLETIC SUCCESS: AN OVERVIEW. Am. J. Sports Med., 12(3): 212-217, 1984.

Gollnick, P.D., Piehl, K., Karlsson, J., & Saltin, B. GLYCOGEN DEPLETION PATTERNS IN HUMAN SKELETAL MUSCLE FIBRES AFTER VARYING TYPES AND INTENSITIES OF EXERCISE. in H. Howald and J.R. Poortsman (eds.), Metabolic Adaption to Prolonged Physical Exercise. Basel: Birkhauser Verlag, 416-421, 1975.

Gollnick, P.D., Piehl, K., & Saltin, B. SELECTIVE GLYCOGEN DEPLETION PATTERN IN HUMAN SKELETAL MUSCLE FIBRES AFTER EXERCISE OF VARYING INTENSITY AND AT VARYING PEDALLING RATES. J. Appl. Physiol., 241: 45-57, 1974b.

Green, H.J., Houston, M.E., Thomson, J.A., Sutton, J.R., & Gollnick, P.D. METABOLIC CONSEQUENCES OF SUPRAMAXIMAL ARM WORK PERFORMED DURING PROLONGED SUBMAXIMAL LEG WORK. J. Appl. Physiol. : Respirat. Environ. Ex. Physiol., 46(2): 249-255, 1979.

Grimby, L., & Hannerz, J. FIRING RATE AND RECRUITMENT ORDER OF TOE EXTENSOR MOTOR UNITS IN DIFFERENT MODES OF VOLUNTARY CONTRACTION. J. Appl. Physiol., 264: 865-879, 1977.

Gydikov, A.A., & Tankov, N.T. DISCHARGE PATTERNS OF TONIC AND PHASIC MOTOR UNITS UPON FLEXION REFLEX IN MAN. P.V. Komi (ed), In Biomechanics V-A Baltimore University Park Press, 1976.

Hermansen, L., & Stensvold, I. PRODUCTION AND REMOVAL OF LACTATE DURING EXERCISE IN MAN. Acta. Physiol. Scand., 86:191-201, 1972.

Holloszy, J.D., & Coyle, E.F. ADAPTATIONS OF SKELETAL MUSCLE TO ENDURANCE EXERCISE AND THEIR METABOLIC CONSEQUENCES. J. Appl. Physiol. Respirat. Environ. Ex. Physiol., 56(4): 831-838, 1984.

Hubbard, J.L. THE EFFECT OF EXERCISE ON LACTATE METABOLISM. J. Physiol. (London) 231: 1-18, 1973.

Hultman, E., & Sahlin, K. ACID-BASE BALANCE DURING EXERCISE. in Ex. Sport Sci. Rev., D.S. Hutton and D.I. Miuer (eds), The Franklin Institute Press, Vol. 8:41-128, 1981.

International Union of Biochemistry. ENZYME NOMENCLATURE. E.C. Webb (publ), Orlando Fla., Academic Press Inc., 1984.

Issekutz, B., Jr., Shaw, W.A.S., & Issekutz, A.C. LACTATE METABOLISM IN RESTING AND EXERCISING DOGS. J. Appl. Physiol., 40: 312-319, 1976.

Ivy, J.L., Withers, R.T., Van Handle, P.J., Elger, D.H., & Costill, D.L. MUSCLE RESPIRATORY CAPACITY AND FIBRE TYPE AS DETERMINENTS OF THE LACTATE THRESHOLD. J. Appl. Physiol., 48: 523-527, 1980.

Jacobs, I. LACTATE, MUSCLE GLYCOGEN AND EXERCISE PERFORMANCE IN MAN. Acta. Physiol. Scand., (Suppl) 49, 1981.

Jacobs, I., & Kaiser, P. LACTATE IN BLOOD, MIXED SKELETAL MUSCLE AND FT OR ST FIBRES DURING CYCLE EXERCISE IN MAN. Acta. Physiol. Scand., 114: 461-466, 1982.

Jansson, E. DIET AND MUSCLE METABOLISM IN MAN. Acta Physiol. Scand., (suppl) 487, 1980.

Jansson, E., & Kaijser, L. MUSCLE ADAPTATION TO EXTREME TRAINING IN MAN. Acta Physiol. Scand., 100: 315-324, 1977.

Jobsis, F.F. & Stainsby, N. OXIDATION OF NADH DURING CONTRACTIONS OF CIRCULATED MAMMALIAN SKELETAL MUSCLE. Respir. Physiol. 4: 292-300, 1968.

Johnson, R.E., & Edwards, H.T. LACTATE AND PYRUVATE IN BLOOD AND URINE AFTER EXERCISE. J. Biol. Chem., 118: 427-432, 1937.

Johnson, M.A., Polgar, J., Weightman, D., & Appleton, D. DATA ON THE DISTRIBUTION OF FIBRE TYPES IN THIRTY-SIX HUMAN MUSCLES. J. Neurol. Sci., 18:111-129, 1973.

Jorfeldt, L. METABOLISM OF (L+)- LACTATE IN HUMAN SKELETAL MUSCLE DURING EXERCISE. Acta Physiol. Scand., (suppl) 338:1-67, 1970.

Jorfeldt, L., Juhlin-Dannfelt, A., & Karlsson J. LACTATE RELEASE IN RELATION TO TISSUE LACTATE IN HUMAN SKELETAL MUSCLE DURING EXERCISE. J. Appl. Physiol., 44: 350-352, 1978.

Jones, N., & Ehrsam, R. THE ANAEROBIC THRESHOLD. Exer. Sports. Sci. Rev., 10: 49-83, 1982.

Karlsson, J. LACTATE AND PHOSPHAGEN CONCENTRATIONS IN WORKING MUSCLE OF MAN. Acta Physiol. Scand., (suppl) 358, 1971.

Karlsson, J. LOCALIZED MUSCULAR FATIGUE: ROLE OF MUSCLE METABOLISM AND SUBSTRATE DEPLETION. Exer. Sport Sci. Rev., The Calimore Press, Toronto, vol.1-42, 1979.

Karlsson, J., & Jacobs, I. ONSET OF BLOOD LACTATE ACCUMULATION DURING MUSCULAR EXERCISE AS A THRESHOLD CONCEPT : THEORETICAL CONSIDERATIONS. Int. J. Sports Med., 3:190-201, 1982.

Karvonen, J., Chwalbinska-Moneta, J., & Saynajakangas, S. COMPARISON OF HEART RATES MEASURED BY ECG AND MICROCOMPUTER . The Physician and Sportsmedicine, 12(6) : 65-69, 1984.

Katz, J., & McGarry, J.D. THE GLUCOSE PARADOX : IS GLUCOSE A SUBSTRATE FOR LIVER METABOLISM ? . J. Clin. Invest. 74:1901-1909, 1984.

Keppel, G. DESIGN AND ANALYSIS A RESEARCHERS HANDBOOK. J.J.Jenkins (ed), New Jersey, Prentice Hall, 1973.

Klausen, K., Rasmussen, B., Clausen, J.P., & Trap-Jensen, J. BLOOD LACTATE FROM EXERCISING EXTREMITIES BEFORE AND AFTER ARM OR LEG TRAINING. Am. J. Physiol., 227: 67-72, 1974.

Kontron, Medical. LACTATE ANALYZER 640- OPERATING MANUAL", Part No. 930 0583, Aug. 1981.

Krebs, E.G., Love, D.S., Bratvold, G.E., Trayser, K.A., Meyer, W.L., & Fischer, E.H. PURIFICATION AND PROPERTIES OF RABBIT SKELETAL MUSCLE PHOSPHORYLASE B KINASE. Biochemistry, 3: 1022-1033, 1964.

Lannergren, J. CONTRACTILE PROPERTIES AND MYOSIN ISOENZYMES OF VARIOUS KINDS OF XENOPUS TWITCH MUSCLE FIBRES. J. Muscle Res. Cell Motility, 8, 260-273, 1987.

Laughlin, M.H., & Armstrong, R.B. MUSCLE BLOOD FLOW DURING LOCOMOTORY EXERCISE. Exer. Sports Sci. Rev., The Callamore Press, Vol.13: 95-136, 1985.

Leger, L. & Thivierge, M. HEART RATE MONITORS: VALIDITY, STABILITY, AND FUNCTIONALITY. The Physician and Sportsmedicine, 16(5): 143-151, 1988.

Liljestrand, S.H., & Wilsson, D.W. THE EXCRETION OF LACTIC ACID IN THE URINE AFTER MUSCULAR EXERCISE. J. Biol. Chem., (65) 773-782, 1925.

Lithell, H., Cedermark, M., Froberg, J., Tesch, P., & Karlsson, J. INCREASE OF LIPOPROTEIN-LIPASE ACTIVITY IN SKELETAL MUSCLE DURING HEAVY EXERCISE. Metabolism, 30: 1130-1134, 1981.

Mackenzie, M.B. THE RELATIONSHIP BETWEEN BLOOD LACTATE AND FORCE PRODUCTION IN ELITE CROSS COUNTRY SKIERS. Masters Thesis, University of Ottawa, 1989.

Magel, J.R., McArdle, W.D., Toner, M., & Delio, D.J. METABOLIC AND CARDIOVASCULAR ADJUSTMENT TO ARM TRAINING. J. Appl. Physiol., 45:75-79, 1978.

Mazzeo, R.S., Brooks, G.A., Bundinger, T.F., & Schoeller, D.A. PULSE INJECTION ($1-^{13}\text{C}$) TRACER STUDIES OF LACTATE METABOLISM IN HUMANS DURING REST AND TWO LEVELS OF EXERCISE. Biomed. Mass. Spectrom. 9: 310-314, 1982.

Mazzeo, R.S., Brooks, G.A., Schoeller, D.A., & Bundinger, T.F. DISPOSAL OF BLOOD ($1-^{13}\text{C}$) LACTATE IN HUMANS DURING REST AND EXERCISE. J. Appl. Physiol., 100(1):232-241, 1986.

McGilvery, R.W. BIOCHEMISTRY: A FUNCTIONAL APPROACH. Second Edition, W.B. Saunders Company, Philadelphia, Pa., 463-481, 1979.

Millerhagen, J.O., Kelly, J.M., & Murphy, R.J. A STUDY OF COMBINED ARM AND LEG EXERCISE WITH APPLICATION TO NORDIC SKIING. Can. J. Appl. Sport Sci., 8(2):92-97, 1983.

Mustardi, R.A., Gandee, R.N., & Norris, W.A. EXERCISE TRAINING USING ARMS AND LEGS VERSUS LEGS ALONE. Archives of Physical Med. & Rehab., 62: 332-336, 1981.

Newgard, C.B., Hirsch, L.J., Foster, D.W., & McGarry, J.D. STUDIES ON THE MECHANISM BY WHICH EXOGENOUS GLUCOSE IS CONVERTED INTO LIVER GLYCOGEN IN THE RAT : A DIRECT OR INDIRECT PATHWAY. J. Biol. Chem. 258: 8046-8052, 1983.

Pendergast, D., Cerretelli, P., & Rennie, D.W. AEROBIC AND GLYCOLYTIC METABOLISM IN ARM EXERCISE. J. Appl. Physiol.: Respirat. Environ. Ex. Physiol. 47(4): 754-760, 1979.

Peter, J.B., Barnard, R.J., Edgerton, V.R., Gillespie, C.A., & Stemel, K.E. METABOLIC PROFILES OF THREE TYPES OF SKELETAL MUSCLE IN GUINEA PIGS AND RABBITS. Biochem. 11:2627-2633, 1972.

Petrofsky, J.S., Phillips, C.A., & Lind, A.R. THE INFLUENCE OF FIBRE COMPOSITION, RECRUITMENT ORDER AND MUSCLE TEMPERATURE ON THE PRESSOR RESPONSE TO ISOMETRIC CONTRACTIONS IN SKELETAL MUSCLE OF THE CAT. (suppl). 1, Circ. Res., Vol. 48, No. 6, 32-36, June, 1981.

Pirnay, F., Lamy, M., Dugardin, J., Deroanne, R., & Petit, J.M. ANALYSIS OF FEMORAL VENOUS BLOOD DURING MAXIMUM MUSCULAR EXERCISE. J. Appl. Physiol., 33: 289-292, 1972.

Polar Electro OY. SPORT TESTER 3000 - TRAINING ANALYSIS PROGRAM FOR THE IBM/PC VERSION 1.0. Hakamaantie 18, SF-9044, Kempele, Finland.

Racine, P., Englehardt, R., Higelin, J.C., & Mindt, W. AN INSTRUMENT FOR THE RAPID DETERMINATION OF L- LACTATE IN BIOLOGICAL FLUIDS. Med. Instrum., 9: 11-14, 1975.

Reed, A., & Thoden, J.S. Unpublished Data. University of Ottawa, 1986.

Riley, D.A. HISTOCHEMICAL CHANGES IN ATPASE ACTIVITY DURING REGENERATION OF ADULT SKELETAL MUSCLE FIBRES. Exp. Neurol., 41: 690-704, 1973.

Rosler, K., Hoppeler, H., Conley, K.E., Claassen, H., Gehr, P., & Howald, H. TRANSFER EFFECTS IN ENDURANCE EXERCISE.- ADAPTATIONS IN TRAINED AND UNTRAINED MUSCLES. Eur. J. Appl. Physiol., 54: 355-362, 1985.

Saar, P., & Schier, A. TESTING OF ELITE CROSS COUNTRY SKIERS. Cross Country Canada, 8-20, 1984.

Sale, D.G., & Norman, R.W. TESTING OF STRENGTH AND POWER. in Physiological Testing of the Elite Athlete., J.D. MacDougall, H.A. Wenger and H.J. Green (ed), Mutual Press Ltd., 7, 1982.

Saltin, B., & Gollnick, P.D. SIGNIFICANCE FOR METABOLISM AND PERFORMANCE. in Handbook of Physiology, Peachy, L.D., Adrian, R., & Geiger, S.R.(eds.), Section 10: Skeletal Muscle. Baltimore, The Williams & Wilkins Co., 555-631, 1983.

Saltin, B., Nazar, K., Costill, D., Stein, E., Jansson, E., Essen, B., & Gollnick, P.D. THE NATURE OF THE TRAINING RESPONSE: PERIPHERAL AND CENTRAL ADAPTATIONS TO ONE-LEGGED EXERCISE. Acta. Physiol. Scand., 96: 289-305, 1976.

Sawka, M.N. PHYSIOLOGY OF UPPER BODY EXERCISE. Ex. Sport Sci. Rev., Vol. 13:175-211, 1986.

Schwade, J., Blomquist, C.G., & Shapiro, W. A COMPARISON OF THE RESPONSE TO ARM AND LEG WORK IN PATIENTS WITH ISCHEMIC HEART DISEASE. American Heart Journal, 94: 203-208, 1977.

Secher, N. CENTRAL AND REGIONAL CIRCULATORY EFFECTS OF ADDING ARM TO LEG EXERCISE. Acta Physiol. Scand., 100 : 288-297, 1977.

Secher, N.H., Ruberg-Larsen, N., Binkhorst, R.A., & Bonde-Petersen, F. MAXIMUM OXYGEN UPTAKE DURING ARM CRANKING AND COMBINED ARM PLUS LEG EXERCISE. J. Appl. Physiol., 36: 515-518, 1974.

Shepherd, J.T., Blomqvist, C.G., Lind, A.R., Mitchell, J.H., & Saltin, B. STATIC (ISOMETRIC) EXERCISE - RETROSPECTION AND INTROSPECTION. (suppl.) Circ. Res. Vol. 48, No. 6, 179-188, June, 1981.

Sjodin, B., "LACTATE DEHYDROGENASE IN HUMAN SKELETAL MUSCLE", Acta Physiol. Scand., (suppl), 436, 1976.

Stamford, B.A., Weltman, A., & Fulco, C. ANAEROBIC THRESHOLD AND CARDIOVASCULAR RESPONSES DURING ONE VERSUS TWO-LEGGED CYCLING. The Research Quarterly, 49(3), 351-362, 1978.

Stanley, W.E., Gertz, E.W., Wisneski, J.A., Neese, R.A., Morris, D.L., & Brooks, D.A. LACTATE EXTRACTION DURING NET LACTATE RELEASE BY THE EXERCISING LEGS OF MAN. J. Appl. Physiol. 60(4), 1116-1120, 1986.

Stark, R.M. BLOOD LACTATE THRESHOLD DETERMINATION IN ELITE CROSS COUNTRY SKIERS ON A SKI TREADMILL. Masters Thesis, University of Ottawa, 1989.

Staudte, H.W., & Pette, D. CORRELATIONS BETWEEN ENZYMES OF ENERGY SUPPLYING METABOLISM AS A BASIC PATTERN OF ORGANIZATION IN MUSCLE. Comparative Biochemistry and Physiology, 41B: 533-540, 1972.

Stenberg, J., Astrand, P.O., Ekbohm, B., Royce, J., & Saltin, B. HEMODYNAMIC RESPONSE TO WORK WITH DIFFERENT MUSCLE GROUPS, SITTING AND SUPINE. J. Appl. Physiol., 22:61-70, 1967.

Thoden, J., Wilson, B., & MacDougall, D. TESTING AEROBIC POWER. in Physiological Testing of the Elite Athlete, MacDougall, D., Wenger, H., Green, H., (eds), Canadian Association of Sports Sciences, 39-60, 1982.

Thorstensson, A. MUSCLE STRENGTH, FIBRE TYPES AND ENZYME ACTIVITIES IN MAN. Acta Physiol. Scand. (suppl), 443, 1-45, 1976.

Vokac, Z., Bell, H., Bantz-Holter, E., & Rodahl, K. OXYGEN UPTAKE/HEART RATE RELATIONSHIP IN LEG AND ARM EXERCISE, SITTING AND STANDING J. Appl. Physiol., 39:54-59, 1975.

Appendices

Appendix A

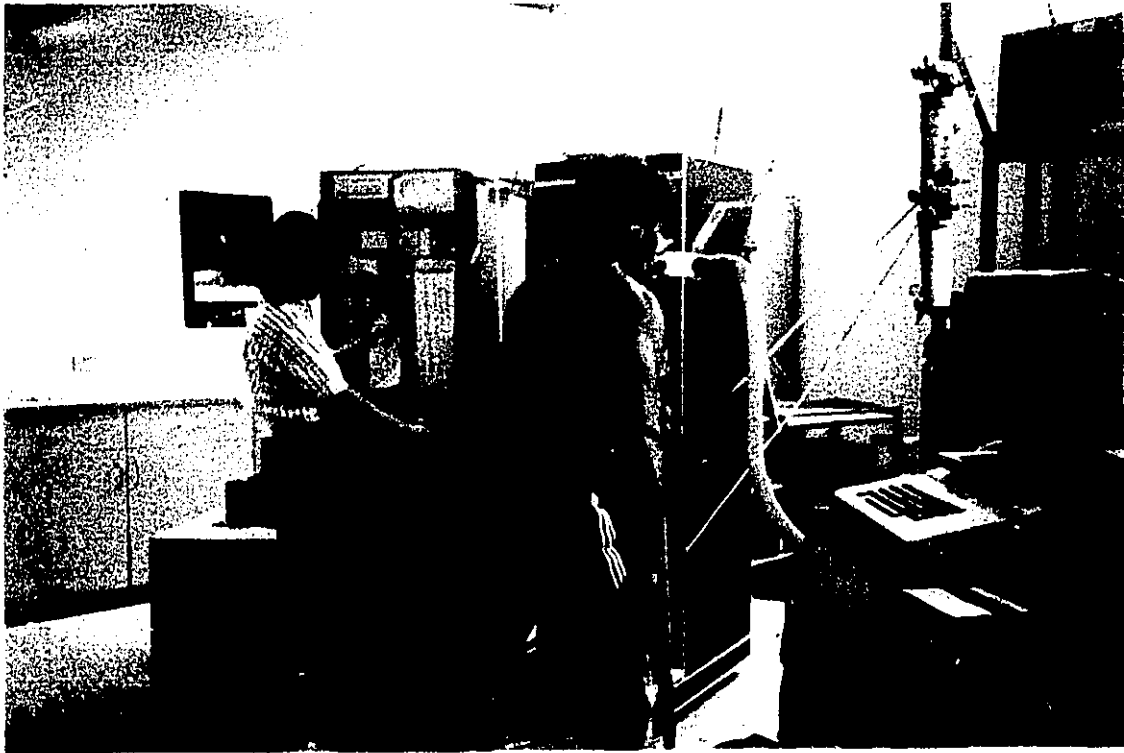
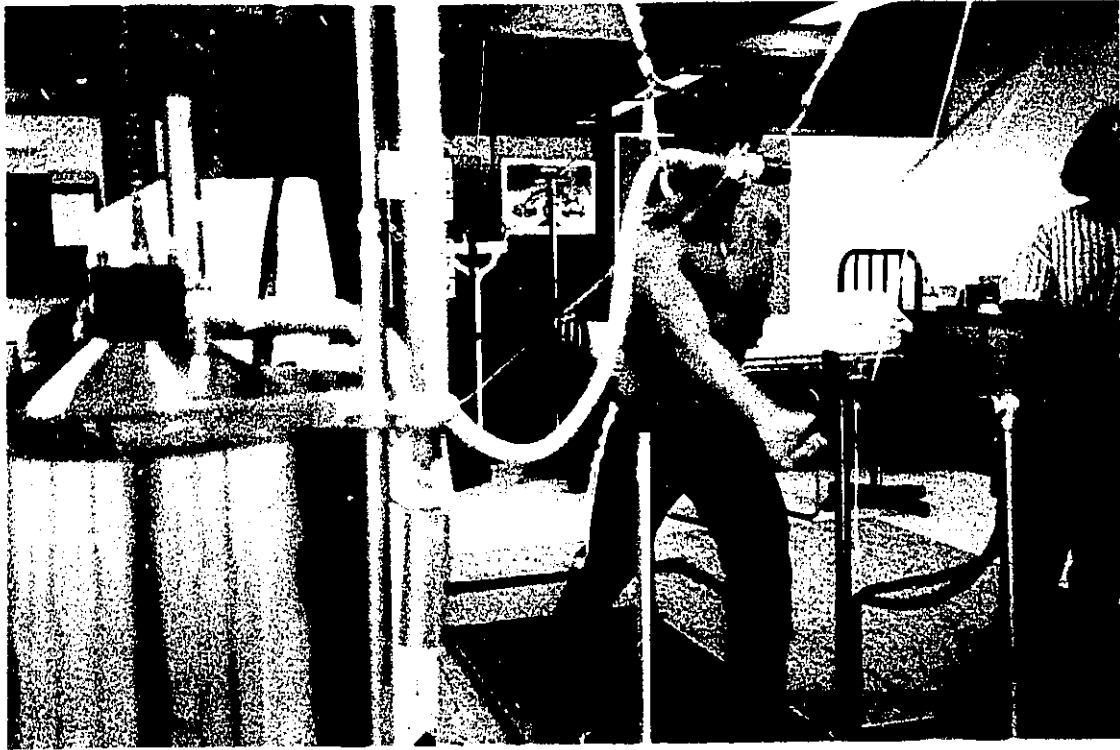

Phase One Ski Treadmill

Appendix B

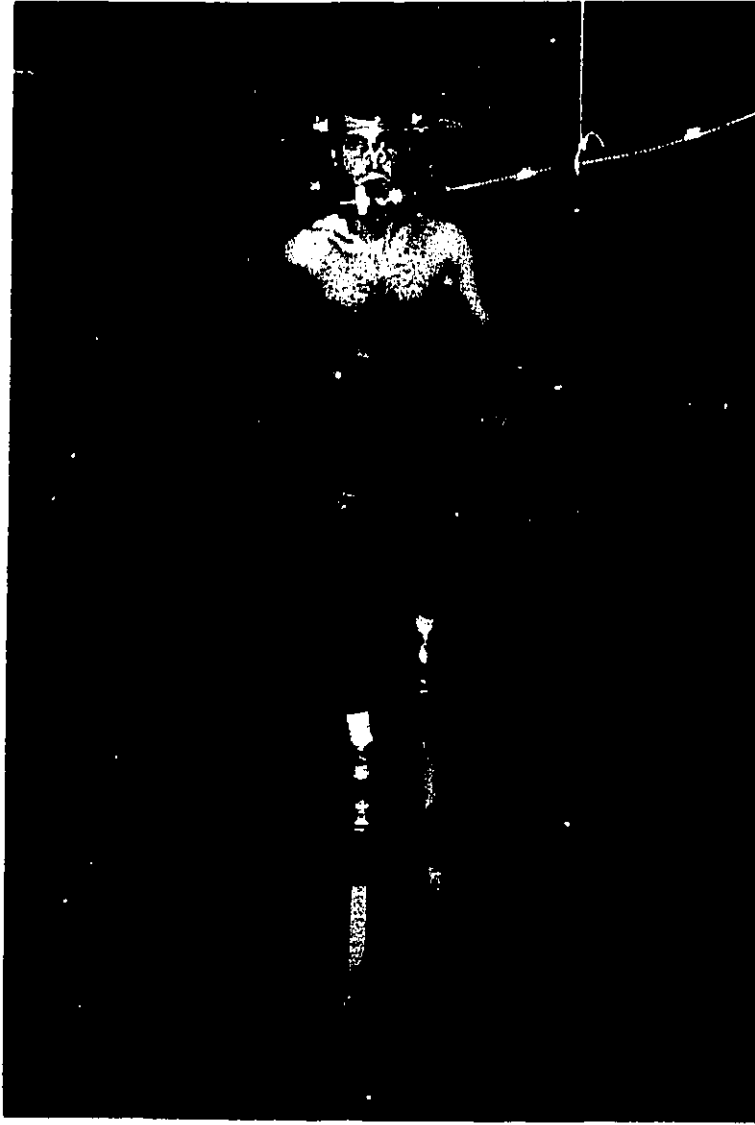

Phase Two Ski Treadmill

Appendix C

The Rollerboard Plan

Exercises:
Kneel on trolley.
Use board for sit-ups

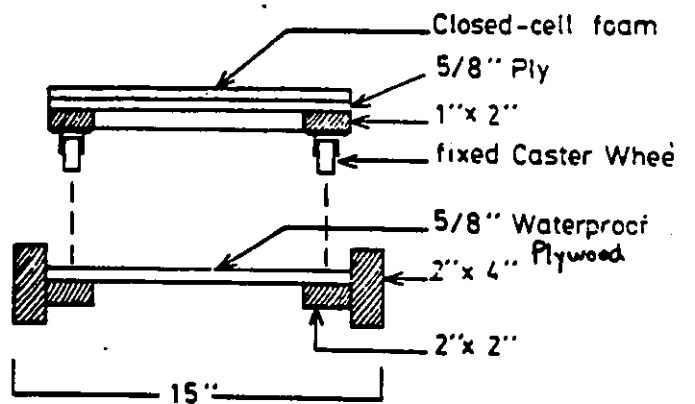
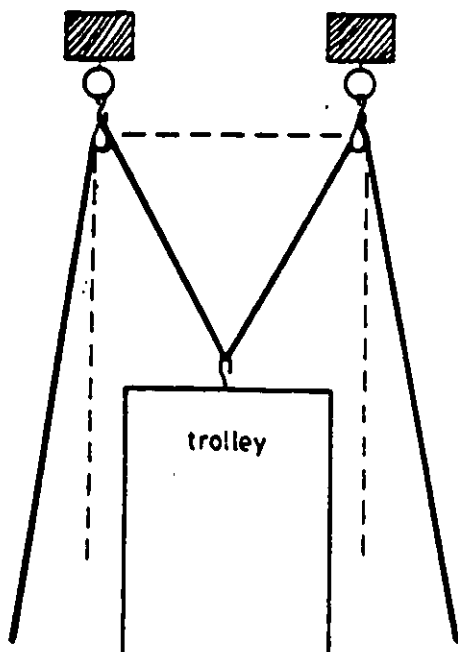
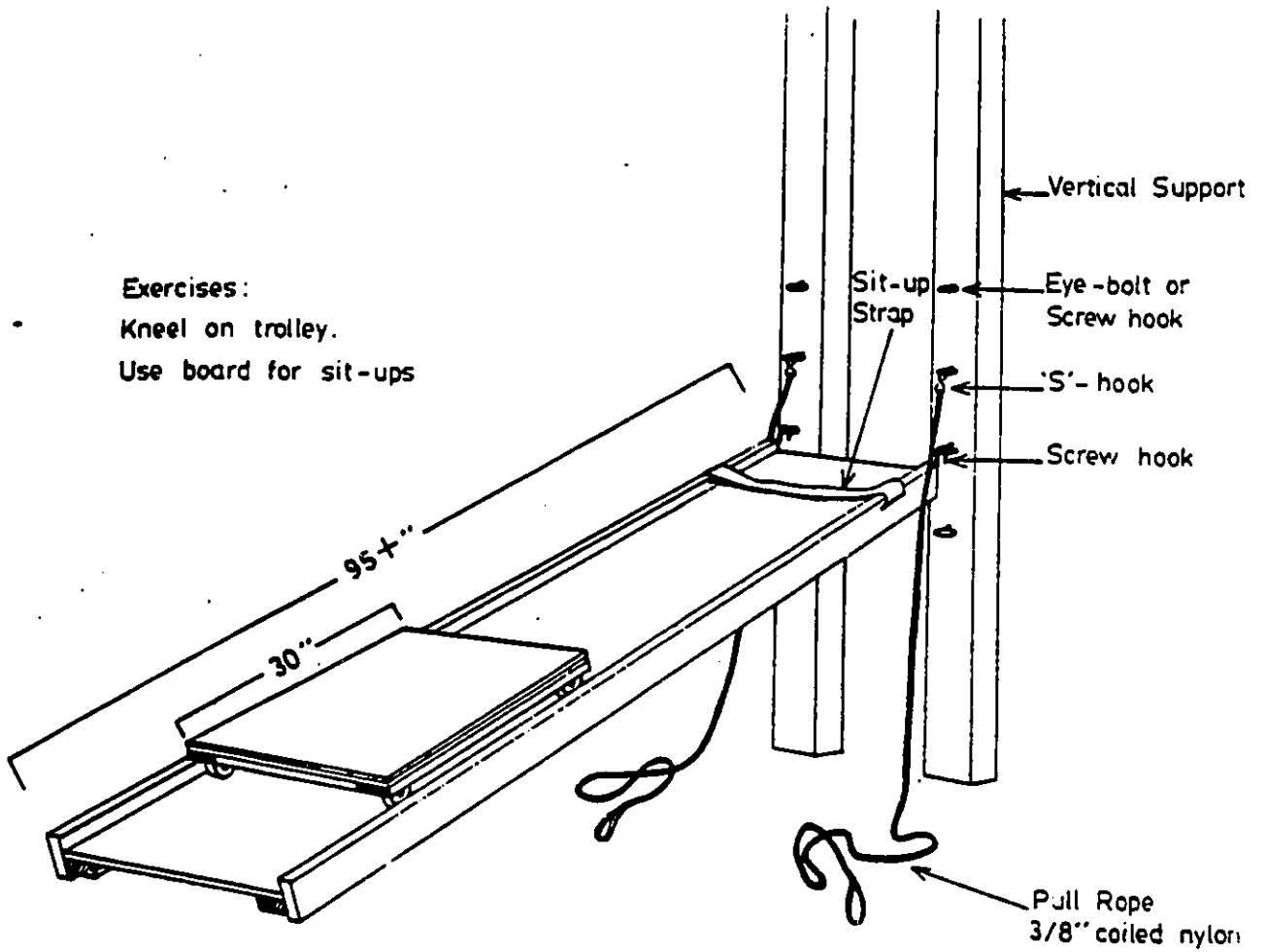

- Alternate pull-rope pattern:
- rope hooks directly to trolley via pulleys on support

Appendix D

