

APPLICATION OF THE ELECTRON MICROSCOPE
TO THE DETECTION OF AIRBORNE VIRUS:

EVALUATION OF A SYSTEM

by

Douglas A. Kennedy

A thesis submitted in partial fulfilment
of the requirements for the degree of
Master of Science.

Department of Microbiology and Immunology,
Faculty of Medicine,
University of Ottawa,
Ottawa, Canada.

"CAUTIONS IN VIEWING OBJECTS"

Beware of determining and declaring your Opinion suddenly on any Object; for Imagination often gets the Start of Judgment, and makes People believe they see Things, which better Observations will convince them could not possibly be seen: therefore offer nothing till after repeated Experiments and Examinations in all Lights, and in all Positions.

When you employ the Microscope, shake off all Prejudice, nor harbour any favourite Opinions; for, if you do, it is not unlikely Fancy will betray you into Error, and make you think you see what you would wish to see.

Remember, that Truth alone is the Matter you are in Search after; and if you have been mistaken, let no Vanity seduce you to persist in your Mistake.

Push no Judgment upon Things over-extended by Force, or contracted by Dryness, or in any Manner out of their natural State, without making suitable Allowances.

—Henry Baker

Of Microscopes, and the Discoveries Made Thereby

Vol. I, Chapter XV

Read before the Royal Society, October 28, 1742

ACKNOWLEDGEMENTS

I would like to acknowledge gratitude to the Defence Research Board of Canada, under whose auspices this work was begun; in particular, thanks are due to P. Cavanagh and L.G. Wilson for their assistance with electron microscopy and associated techniques, and to J. F. Currie and D.C. O'Connell and the staff of the Applied Microbiology Section for their help and encouragement.

The staff and my fellow graduate students in the Department of Microbiology and Immunology have contributed in many ways with the provision of help, advice and materials, and to all concerned, I express my gratitude.

I would further like to express my sincere thanks to my supervisor, Dr. J.C.N. Westwood, who is responsible for the concept upon which this work is founded and to Dr. C.M. Johnson, in whose laboratory the research was completed.

ABSTRACT

On the basis of epidemiological data, aerial transmission of certain virus diseases is regarded as fact. Experimental data to elucidate the mechanisms involved, however, is scanty.

Reviewing laboratory effort in this field, it may be seen that the detection and characterization of air-borne virus is one area in which current approaches have been less than satisfactory. Methods presently in use are time-consuming and elaborate, and have frequently failed to detect virus in conditions where air-borne contagion was thought to occur.

In view of the successful use of electron microscopy in diagnostic virology, it was proposed that this technique might be applied to the detection of air-borne virus. Calculations were made which indicated that this approach was capable of providing a sensitive detection system. An experimental plan was formulated to bear out these calculations and to test the assumptions upon which they were based. Progress in realizing this plan is presented.

TABLE OF CONTENTS

<u>Introduction</u>	<u>Page</u>
Evidence for airborne transmission of virus.	1
Application of electron microscopy to virus diagnosis.	10
Electron microscopy in the detection of airborne virus.	13
Experimental Plan	22
<u>Selection of Viruses</u>	24
<u>Demonstration of Viral Morphology</u>	
Introductory remarks.	26
Materials and methods.	35
Results and Discussion.	40
<u>Quantitative Studies</u>	
Introductory remarks.	68
Materials and methods.	70
Results and discussion.	76
<u>General Discussion</u>	89
<u>Summary</u>	93
<u>Appendices</u>	94
<u>References</u>	103

INTRODUCTION

1. Evidence for Airborne Transmission

The concept of transmission of disease by the aerial route, with its origins in antiquity, has persisted to the present day where it is regarded as fact, although discussion does continue as to its importance and the mechanics involved in the process. The history of investigation into this phenomenon has been documented in several reviews (Gordon and Ingalls, 1957; Williams, 1960; Langmuir, 1961, 1964; Hare, 1964; Dowling, 1966).

In the more particular cases of viruses, review of a standard textbook such as that of Davis et al. (1968) will reveal that this mode of spread is mentioned in relation to a large number of viruses. (Table I). The evidence implicating these viruses in airborne infection varies in strength, but in the best of cases is quite convincing. For example, Riley and O'Grady (1961) report an extensive series of observations on measles epidemics among school children where the attack rate enabled calculation of virus concentration in the environment, and control of spread by ultraviolet irradiation of the air confirmed the postulated route. More recently, an outbreak of smallpox in Meschede, Germany (Wehrle et al., 1970) has led to comment in leading medical journals (Med.J. Aust., 1970; Brit.Med.J., 1970) because of its dramatic nature. Victims in this outbreak included persons isolated in a hospital environment both from direct or indirect contact with the source case,

TABLE ISome Viruses Transmitted by the Airborne RouteRespiratory Diseases¹ Non-respiratory diseases

influenza	poliovirus
parainfluenza	mumps
respiratory syncytial	rubella
rhinovirus	rubeola
adenovirus ²	varicella
coxsackievirus ²	variola
echovirus ²	

1. Division into respiratory vs. non-respiratory is arbitrary, based upon predominant symptoms.
2. Some serotypes of this group.

except that the airflow from the source's environment could be demonstrated by smoke tests to be entering the areas where these persons contracted the disease.

Studies of laboratory acquired disease reveal that tracing the infection to a contact-type event is often difficult, leading several noted reviewers to the conclusion that transmission of virus in aerosol form probably accounts for the majority of these accidents (Sulkin, 1961; Chatigny, 1961; Wedum, 1964; Sulkin and Pike, 1969). Interestingly, the listing of the latter authors includes viruses whose natural mode of spread is known not to be through the air.

Coupled to these observations in the natural and laboratory accident fields, and reviewed by those authors, there is experimental evidence in support of their conclusions dealing with the production of microbial aerosols both by natural events and by common laboratory procedures. A listing by Akers (1969) demonstrates a wide range of viruses for which survival in the airborne state and the production of infection from inhalation of these particles has been studied, further contributing to the credibility of this route. Again, this list includes a number of viruses not known to be thus transmitted in nature, for example the arboviruses are quite surprising in this context.

In short, then, there is little doubt that aerial spread of virus infection can and does occur. It must be borne in mind, however, that much of the supporting evidence

is circumstantial in nature, derived from observation of patterns of spread and supported by the knowledge that mechanisms capable of mediating the transfer have been demonstrated. While this evidence supports the central thesis, it leaves room for dispute as to the relevance of the air as a menstruum of transfer, and, accepting that aspect for a premise, one still finds disagreement on other points such as the source of airborne virus.

Hare (1964), discussing the transmission of respiratory infection, states that he cannot agree with Wells' (1934) conclusion that airborne droplet nuclei are the principal means of contagion, since his own review revealed much work showing a) the best source of aerosolized material seems to be the anterior portion of the mouth and b) most of the material expelled was in the form of large droplets which would almost immediately settle out on surfaces. The small mass of droplets in the size range capable of remaining airborne would thus contain only a very small proportion of the organisms expelled from the infected individual. Since this source is not one expected to contain much virus, he concludes that direct expulsion into the air is not the probable source of aerosols of infectious organisms. Rather, reviewing the work of several groups concerned with the mode of spread of certain bacteria in hospitals, he believes that resuspension of organisms from contaminated skin and fabric

could best account for dissemination into environment.

A report by Downie et al. (1965) is similar. Their studies on smallpox show that most virus is released from the patients in the form of secretions transferred directly to bedding and skin. When expelled by coughing and other respiratory functions, it is predominantly in large droplets which were recovered more readily by settling plates than by impinger. Thus most of the infective virus finds its way to the bedding or the patients' skin, and they conclude that air contamination in the vicinity would be from particles which have been resuspended as secondary aerosols.

Thus, in the example above two schools of thought are evident regarding the origin of airborne virus, the "orthodox" proposal of Wells (1934, 1955) implicating droplet nuclei versus the secondary aerosol idea proposed by Hare and by Downie et al. Similar controversy exists in other areas of airborne infection theory and no definitive solution can be reached by analogy or on probabilistic grounds alone. A thorough understanding will be achieved only by experimental examination of the process in realistic situations.

The primary objective in any such experimental programme must be the demonstration of airborne infection. Secondary objectives will be designed to reveal the mechanisms by which the process is accomplished. For example:

Secretion of virus in an infected individual. By what routes and in what quantities can the virus leave the

source case? Findings would suggest infectious potential of a donor case and routes of transfer likely to be of importance. Alternate routes may be revealed.

Aerosolization of the virus. Is the virus suspended in droplet nuclei or does it become resuspended after deposition in the environment? Control measures may be based on these findings and the relative hazard from the individual as opposed to his former surroundings may be judged.

Concentration of virus in the air. At what level do we find virus present and does it account for observed infection rates? With additional information this data could enable evaluation of the infectious hazard of the air, which, in turn, could be used to derive ventilation rates necessary for the prevention of spread.

Size of virus-bearing particulates. From this data one could estimate their mobility in the environment as well as their ultimate fate in the respiratory tract if inhaled. Biological characteristics of microbial aerosols have been shown to vary with this parameter as well.

Biological activity of the virus in air. Most important, of course, is the infectious potential.

What is the capability of virus in the concentrations and particle sizes determined above regarding the production of disease? Is this potential associated with one size class, and is it maintained over long periods? The answers again have implications for our understanding and control of the process of spread. Primary site of infection in the recipient. This information would further our insight into host defences.

Similar objectives have been recommended by Morton (1963) and Tyrrell (1965).

Examination of the experimental record reveals that one of the more difficult links to establish in this particular chain of transmission has been the demonstration of airborne virus. Experiments such as those reported by Artenstein and Cadigan (1964) and Downie et al. (1965), in spite of being highly biased to favour recovery of airborne virus, were characterized by very low recovery rates. Recent investigations have been more successful, however, and this change in outcome coincides with the introduction and use of large volume air sampling techniques. From the Second International Conference on Aerobiology, Artenstein and Miller (1966) reported isolation of meningococcus and adenovirus from army recruits suffering from respiratory disease and from the air surrounding them, while reports by Couch et al. (1966) and Gerone et al. (1966) described the recovery of coxsackievirus type A 21 from the environs of infected volunteers by air sampling.

A common feature of these latter studies is the finding of low concentrations of virus in the air. Artenstein and Miller recovered 1 TCD₅₀ of adenovirus per 1000 to 3000 cubic feet of room air surrounding infected volunteers, while Gerone et al. found 1 TCD₅₀ of coxsackievirus in 10 to 300 cubic feet. The occurrence of a high proportion of negative samples in these experiments would indicate that the average concentration is lower yet. Data for many viruses are not available, but there is epidemiological evidence that one infectious unit of measles may be present in an average of 3000 cubic feet of classroom air during school epidemics (Riley and O'Grady, 1961).

Considering these figures and the sampling rates of the collection devices used in earlier studies, the failures in isolating virus from the air can be attributed to the use of sampling methods which were not sufficiently sensitive. The large volume sampler, with a much higher concentration factor (volume of air sampled/volume of receiving liquid) would thus seem a necessity in this type of investigation.

Although large volume sampling represents a major advance in technique, several limitations in air sampling capability remain. One such restraint is that the occurrence of a high proportion of negative samples probably indicates that the sensitivity is still marginal. Secondly, attempts at culturing of low concentrations of virus have required extensive laboratory manipulation of the samples; for example,

Artenstein et al.(1967) report the use of "blind passage" in cell culture and requiring periods of up to 42 days for final analysis of their specimens. Investigation of an unknown agent could be further complicated by the necessity of using several cell lines to ensure recovery.

2. Electron Microscopy in Diagnostic Virology

In 1948, Nagler and Rake, extending earlier workers' efforts with the light microscope, first applied the electron microscope (E.M.) to the differential diagnosis of smallpox and varicella. The former's large size just puts it within range of detection by a good light microscope, while that of the latter is below the resolution limit of this equipment. In the electron microscope, however, both are detectable, and, using the shadowing techniques available at that time, size and shape differences enabled the authors to make the distinction required. Van Rooyen and Scott (1948), while recognizing variola, were unable to confirm the findings with respect to varicella.

In 1949, herpesvirus particles were also seen in cerebro-spinal fluid (Evans and Melnick, 1949) and a papovavirus was found in material from common warts (Strauss et al. 1949), but progress was not rapid during the next ten years, probably due to the preparative procedures available at that time - shadow casting giving rather poor structural definition due to granulation of the deposit and distortions of the particles during drying, and thin sectioning was in its infancy. Although the latter technique was to develop in later years and has indeed been used in diagnosis of viral infections, it has played a secondary role due to its lower information content and the involved nature of the preparative procedures

when compared to techniques later developed.

In 1959, with description of the conditions for routine use of negative staining by Brenner and Horne, the "molecular architecture" of viruses was rendered visible in the electron microscope in considerable detail, leading to a large volume of descriptive literature in the next few years. In 1961, Cooper proposed that virus chemistry be included as a prime criterion in taxonomy, and an extension of this idea to include morphology by Lwoff et al. in 1962 was accepted by the Provisional Committee for the Nomenclature of Viruses as a basis for classification in 1965. Expansions of this basic scheme are in widespread use at present.

As these developments would seem to hold obvious implications for the use of morphology in the diagnostic field, permitting assignment to at least group level, it is somewhat surprising that effort in this area continued to be associated exclusively with the pox, herpes and papova groups. However, in 1967 Doane et al. examined nasopharyngeal secretions from tracheitis patients and were able to detect paramyxovirus in these specimens. Joncas et al. (1969) similarly reported microscopic detection of respiratory syncytial virus and a para-influenza type 2 from patients with lower respiratory infection, and the more recent paper by Doane et al. (1969) described further extension of the range of samples examined, and the addition of adenovirus and reovirus to the list of viruses detected

directly in clinical specimens. The latter paper also points out the use of this instrument in detecting virus from cell cultures showing ambiguous cytopathic effect, as well as in revealing the presence of contaminating viruses in apparently normal cell cultures.

On the basis of this proven success in diagnostic virology it was proposed that the electron microscope might be used for the detection of airborne viruses.

3. Detection of Airborne Virus

To consider application of electron microscopic detection of virus to the area of airborne transmission of disease, it may be seen from the above that detection should allow assignment of virus at least to a major group, and point out the appropriate laboratory approach for confirmation and identification by conventional means. This technique should be applicable to a wide range of viruses, and be independent of foreknowledge of the virus type concerned. Lastly, it should shorten the time scale required for detection, and provided the investigating laboratory has a microscope available to it, would simplify the procedures required for a final solution.

To arrive at an evaluation of feasibility, based upon sampling the air and examination of the sampler fluid in the electron microscope, several factors must be considered:

- a. Performance of the sampler
- b. Quantitative characteristics of the preparative techniques for microscopy, and
- c. Relevance of data obtained in this manner to infectiousness of the aerosol.

The first two points could be at least partially resolved by consideration of the literature, whereas the third will require experimental data for precise evaluation.

Information regarding the performance of the sampler is available in the scientific literature only for the Litton device (Gerone et al., 1966), which indicates it is a quantitative sampler of efficiency comparable to the standard impinger samplers. This device has been used by Artenstein et al., (1967) to collect at an air-to-liquid ratio of 860 litres (l.) of air into one millilitre (ml.) of liquid, based on initial volume of liquid, whereas evaporation during sampling can reduce this volume by at least one quarter (Gerone et al., 1966), which would raise this figure to 1100 l./ml. Recycling of collection fluid could further boost this ratio. For the purpose of discussion, we will assume that a concentration ratio of 1000 l. of air to 1 ml. of fluid is attainable. Furthermore we will assume that its physical efficiency is high, approaching 100% for micron-sized particles even though its biological efficiency may be less, and somewhat less predictable.

Turning next to electron microscopy, the methods used in diagnostic work generally are not quantitative in nature, nor are they particularly sensitive, properties which are both necessary in the application we envisage. Quantitative characteristics are required so that levels of hazard may be judged, and sensitivity, or ability to detect low concentrations of virus, is essential since low concentrations of virus are expected in air sampler effluents. Diagnostic techniques in

use make no claim to give quantitative data, but results reported by Doane et al., (1969) estimate a requirement of about 10^9 virus particles per ml. to be detectable in the E.M. using their preparative methods; these authors are supported by Waterson (1964) in this respect. In contrast Bradley (1967) offers the experience that 10^7 /ml. will produce detectable levels of virus, although higher numbers obviously expedite the examination of large numbers of particles as would be required in a morphological study.

Methods developed for quantitative studies in the E.M. are numerous, and many have been used in conjunction with negative staining. A review by Sharp (1965) contains references to most of the techniques which have been used in virus research. These may be divided into two main classes: the first involves sedimentation of virus from suspension onto a flat surface which can be transferred to the microscope. Particle counts from a defined area can be used to calculate the concentration by reference to the sedimentation geometry. The other class relies upon differential counting of virus and indicator particles where the volume containing each was known and the concentration of the latter group can be determined accurately by an independent means. Since both classes are adaptable to negative staining, a method of either type could be used, and thus the choice must be made upon the basis of sensitivity, that is, the minimum

concentration of viruses necessary for detection in the E.M.

Examination of a specimen for counting virus particulates will normally be done at a magnification just high enough to enable differentiation between viral and non-viral material; at this level, a maximum number of particles can be counted per field. For any one technique, the number per field at this magnification will vary with the concentration of virus in the suspension. Alternatively, at a constant concentration, the number per field will vary with the volume of virus suspension which has given up its particles to the grid. Since the area term in this volume is constant at any fixed magnification, the number per field, which is a direct measure of sensitivity, will vary with the height of liquid which has been dried, dialyzed or centrifuged to place its particles on the specimen film. Thus the most sensitive method will be that which deposits virus from the greatest depth of liquid onto the film.

It is evident from the above that the methods which involve direct application of virus suspension to a grid, such as the spray-droplet approach of Williams and Backus (1949) or the dip method of Monroe and Brandt (1970) will be the least able to detect low concentrations since the virus is contained in a layer which is a small fraction of a millimeter in depth; dialysis (Kellenberger and Arber, 1957) or evaporation (Pinteric and Taylor, 1962) of a droplet which may be several millimeters in depth is expected to be more sensitive, while

the highest powered will be the sedimentation methods (Sharp, 1949), which are limited in liquid depth only by the characteristics of the equipment available for spinning the virus down. One important qualification must be added, and that is that the concentration of non-viral, interfering debris must not be high enough to mask the virus, but this applies to all these methods in proportion.

It was therefore decided to explore sedimentation counting in the hope that it would enable direct examination of air sampler material with a minimum of additional manipulation. Calculations based upon the use of an available swing out rotor head (Appendix I) suggested that an average of one virus particle per grid square on a four-hundred mesh grid (27 microns square) could be observed in the E.M. when the concentration of virus in the liquid was 2.6×10^4 per ml. Since one grid square could be scanned at a suitable magnification for virus identification in about a minute, this concentration would not be too exacting of the operator and was accepted as a limit. Given a more patient operator who would scan tens of grid squares, we could consider the limit to be 10^3 particles per ml. or less, and considering there are several hundreds of squares available for viewing, there would be ample left for confirmation of a sighting.

In terms of the sampler operating conditions assumed above, this detection limit would represent 1 to 26 viral

particles per litre of air. Centrifuge equipment is no doubt available which would present a greater depth of liquid to the receiving surface, but it is unreasonable to expect more than a twofold improvement without special equipment.

The significance of detecting 1-26 viral particles per litre of air is not immediately apparent, since the hazard to a susceptible subject is dependent, among other things, upon the relationship of these particles to an infective dose. There is, in turn, much evidence to support the view that the required dose will usually comprise many particles morphologically recognizable as virus; several lines of evidence can be introduced which may permit estimation of this factor, bearing in mind that variables which tend to increase the ratio of virus particles (VP) to infectious units (IU) will extend the sensitivity of electron microscopic detection in relation to the hazard. The converse is of course also true.

Firstly, we may consider the relationship between morphological units as observed in the E.M. and infectious units assayed in a suitable laboratory host system. Reviews of this relationship by Isaacs (1957) and Sharp (1963,1965) indicate that this ratio rarely approaches unity for animal viruses, and in some cases lies in the tens of thousands. Whether the reason for this deviation is insensitivity of the host system, production of non-infectious virus or other factors probably varies with the virus and experimental conditions, several possibilities being reviewed by Sharp (1965), but the fact remains that the ratio usually lies between 10 and 1000 particles per infectious unit.

Related to the above, we encounter the question as to whether viruses which have been aerosolized will also demonstrate "morphological decay", i.e. is the typical

morphology of the virus changed by the act of aerosolization, or does it change upon prolonged storage in the air? In the light of known loss of infectivity due to both these events (Akers, 1969), morphological stability would further raise the ratio VP/IU. There are as yet no studies on this question, but infectivity is not necessarily related to morphology as evidenced by the finding of VP/IU greater than unity. There are also reports dealing with treatment of virus by techniques which reduce their infectivity and so produce higher particle to infectious unit ratios (Kaplan and Valentine, 1959; Galessio and Sharp, 1963). Implicit in this observation is the conclusion that loss of infectivity is not necessarily related to morphological change.

In standard aerobiological experiments, however, biological decay is observed, generally recognizable in two steps - an immediate loss of infectivity upon aerosolization, followed by a slower loss upon storage in aerosol. The magnitude of these losses, as well as their dependence upon relative humidity, temperature, gaseous and ionic composition of the suspending atmosphere may vary with the virus under test but losses over several hours may reduce the infectivity titre several orders of magnitude. In the absence of morphological decay, the implications for a detection system based on electron microscopy are obvious.

An additional observation which will be relevant is that, where determinations have been made of the human infectious

dose of certain viruses, there are examples where the HID_{50} is expressed as a multiple of TCD_{50} . For example from the work of Couch et al., (1966) and Alford et al., (1966), this ratio varies from 0.5 to 28.

Direct determination of the number of viral particles in an infectious dose can of course be determined experimentally, but the considerations above help in assessing the magnitude of this ratio in the absence of exact data.

In conclusion, this type of analysis may be applied to the coxsackievirus infections studied by Gerone et al., (1966), and Couch et al., (1970). From their data, the biological recovery of the large volume air sampler averaged 10%, while the HID_{50} of aerosolized virus is about 30 TCD_{50} . The ratio of virus particles to infective units may be estimated from Sharp's (1965) data as being about 50. Therefore, an airborne infectious dose would be expected to comprise approximately 15,000 virus particles. Since concentrations of 26 particles per litre of air will be detectable in the E.M., this method would be successful when one infectious dose is contained in up to 600 litres of air. Assuming an average breathing rate of 10 litres per minute, this volume will be breathed in one hour.

Thus, a system based upon the use of large volume air sampling and examination of the sampler fluid in the electron microscope could detect coxsackievirus in situations where

infection would occur in one hour or less. Were airborne virus to retain its morphological integrity despite the expected biological decay, the sensitivity of this system would be further extended. Clearly this approach is of potential value but its hypothetical performance must be verified by experimental data.

4. Experimental Plan

In order to evaluate the feasibility of electron microscopic detection of airborne virus, the following experimental approach was adopted:

- a. Selection of a group of viruses as test subjects, varying in morphology and size since it is expected that ease of detection in the electron microscope will vary with these criteria.
- b. Demonstration of their typical morphology as reported in the literature to gain familiarity with the procedures necessary for the study of viral morphology, which would be prerequisite to our task.
- c. Determination of the quantitative performance of the sedimentation counting method chosen with each of the viruses to bear out the calculations on this technique and prove its applicability to these viruses.
- d. Correlation of infectivity with morphology for these viruses:
 - (1) in suspension to supply "base line" data, and
 - (2) in aerosol, using standard aerobiological techniques, to evaluate the magnitude and direction of any changes in this state.

- e. Evaluation of the large volume air sampler (LVAS) with respect to the samplers used above since the physical conditions of sampling in this device differ from those which must be used in (d).
- f. Evaluation of the complete system in a realistic environment.

This thesis comprises the analysis of the concepts reported in the introduction and experimental work relevant to objectives a to c above.

SELECTION OF VIRUSES

A selection of viruses was made primarily to encompass a range of sizes, since the ease of detection in the electron microscope was expected to vary most directly with this parameter. We have included in this group poliovirus, one of the smallest of human pathogens, and vaccinia, a representative of the poxviruses, the largest true viruses to infect man, the rest measuring between these two extremes (Table II).

This group contains viruses having both deoxyribonucleic (DNA) and ribonucleic acid (RNA) as their genetic material and most of the known morphological classes are represented. These viruses also differ in their sensitivity to physical and chemical treatments.

Members of each group represented above have been implicated in causing natural and/or laboratory acquired infections by the airborne route.

TABLE IIMorphology of Test Group of Viruses

<u>Virus</u>	<u>Symmetry of Nucleocapsid</u>	<u>Diameter of Nucleocapsid</u>	<u>Remarks</u>
vaccinia	-1	-	Rectangular, 300x250 nm. aspect typical in E.M.
herpes	icosahedral	100 nm.	Enveloped, 200 nm. diameter. Nucleocapsid usually seen.
influenza	helical	9 nm.	Enveloped, pleomorphic, 100 nm. diameter avg. Nucleocapsid not seen.
adeno	icosahedral	75 nm.	Fibers at icosahedral vertices, visibility varies with stain.
echo	icosahedral	25 nm.	Simple icosahedral nucleocapsid.

1. Symmetry of poxvirus nucleocapsid not described.

Morphology of virion is complex.

DEMONSTRATION OF VIRAL MORPHOLOGY

INTRODUCTION

Poxvirus

Vaccinia virus was chosen as a member of the poxvirus group since its appearance is typical of the larger members of this group and can be manipulated with safety in the laboratory. Its morphology is complex, but well described as to surface detail (Westwood et al., 1964, Medzon and Bauer, 1970) and internal structures (Easterbook, 1966).

While the virus is brick-shaped, measuring about 100x250x300 nanometers (nm.), it is usually seen presenting its larger dimensions as a rectangular body 250x300 nm. Two morphological types are seen; in the more common, the surface is covered with an irregular array of threads or tubules about 9 nm. in diameter. These threads, on closer inspection can be seen to have beaded margins, and an interpretation of their structure in terms of a double helix as offered by Westwood et al. fits the morphological data.

The second form seen is similar in shape to the above, but is slightly larger in size. No surface structure is seen, and the body is electron dense, indicating penetration of stain. The rectangular structure is bordered by a zone 25 nm. thick, reminiscent of a thick capsule; this zone can itself be seen to be differentiated, the outer portion being

unstructured, while regular striations on the inner part give a pallisaded effect. This "pallisading" extends into or is repeated by the outer portion of the dense central body.

The relationship between these two types, referred to as "M" and "C" forms respectively (Westwood et al., 1964) was subject to dispute, but they were shown by these authors to be superficial and deeper detail of the same type of particle, the larger size of the latter being due to some loosening of structure and swelling.

Internal structures of the virion have been characterized, but the typical morphology of negatively stained specimens is as described above. The architecture of this virus is complex, and no simple icosahedral or helical symmetry of nucleocapsid has been shown as in the case with the smaller viruses.

Herpesvirus

Herpes simplex is another large, complex virus, but simpler than the above, displaying icosahedral symmetry of the nucleocapsid. The essentials of herpes morphology were described in 1960 by Wildy et al. The outer layer may consist of an envelope, although it is not always present. The envelope is somewhat variable in diameter, but generally about 200 nm., being 4 nm. thick. The surface of the envelope is covered with rod-like projections 8-10 nm. long, spaced at 5 nm. intervals. Function of the envelope, obscure in 1960, remains

unresolved to this day (Watson, 1968, Roizman, 1969). The latter author has inferred a double layered structure, but this is not easily demonstrated in the electron microscope (Roizman et al., 1969).

The nucleocapsid is 105 nm. in diameter, and displays icosahedral form and symmetry. Its surface contains 162 polygonal capsomeres, each 12 to 13 nm. in length, 10 nm. in diameter with a hollow (phosphotungstate penetrated) core of 4 nm. wide. The capsomeres are separated at their bases by 3 nm., giving obvious and distinctive separation between them.

While the above appearance of the nucleocapsid is typical of those not penetrated with phosphotungstate ("full" particles), forms are seen where the area inside the capsomeres is completely filled with stain, giving the effect of a cross section of the capsid. This form corresponds to the "empty" particles described with other viruses. Partially penetrated viruses are also present which reveal the edge of the outer capsid, an electron dense area just inside, with an electron transparent, round area near the centre of the structure, often showing the capsomere structure typical of the nucleocapsid over this area. These intermediate types probably reflect the interaction of phosphotungstate with the "inner capsid" described by Roizman et al., (1969). The inner capsid may itself be "full" or "empty" when examined by negative stain, and intermediate particles are seen which could

represent these states of the inner capsid. Evidence for a "middle capsid", a smooth layer to which the outer capsomeres are apposed or attached has also been presented by these authors.

In general, then, one may encounter either enveloped or naked virus in herpes preparations, and members of either class may be "full", "empty" or of the intermediate type.

Influenza

Influenza is an intermediate sized virus first described in conditions of negative contrast by Horne et al. (1960) as being that of a roughly spherical, markedly pleomorphic structure, studded with rod-like surface projections. By analogy with other members of the myxovirus group (which included the paramyxoviruses), they assumed its nucleocapsid would have helical symmetry, but indications of this feature were only very rarely found in spontaneously disrupted virions.

A later publication by Hoyle et al. (1961), in which ether treated virus was examined, confirmed the suspicions expressed in the former publication. The latter group found that a supercoiled helix of 9 to 10 nm. in diameter could be seen in disrupted viruses. This they identified with the ribonucleoprotein.

The envelope of this virus, which is the feature seen in electron microscopy of untreated virus, is seen to be 6-10 nm. thick, studded with projections about 10 nm. in

length which are separated at a center to center distance of 7-8 nm. The spikes are radially oriented with respect to the body of the virus and have been noted to display "regular packing when seen end on" (Hoyle et al., 1962).

While the above applies to the influenza types A and B, the envelope of the type C viruses is distinctive in the possession of a regular hexagonal-pentagonal lattice visible on the surface of the envelope (Archetti et al., 1967). These authors also feel that the pattern of spikes differ between the A-B group and the C group, being sparser on the latter type. Opposed to this, Flewett and Apostolov (1967, Apostolov and Flewett, 1969) interpret the arrangement of projections on influenza C particles as a pattern which conforms to that proposed by Archetti et al. for the A and B types. The micrographs produced in evidence, however, do not clearly resolve the alternatives.

Adenovirus

Description of the morphology of adenovirus type 5 by Horne et al., (1959) dramatically illustrated the icosahedral shape and symmetry of this virus, representing the first clear evidence of this construction to be revealed by negative staining for any virus. Their study revealed an icosahedral virion of 252 sub units, 240 of which were on the faces or edges of the structure, each having 6 neighbouring units,

while 12 were situated at the vertices, with only 5 neighbours. These capsomeres, as they were later called, were separated by a centre to centre distance of 7 nm., while the whole virus was reported as 70 nm. in diameter.

Wilcox et al., (1963) reported a fiberlike structure associated with the virus particles, but it was not until 1965 that the morphology of the virus was fully understood with the publication of the classic picture of Valentine and Pereira (1965). The latter work demonstrated that the vertex or penton capsomeres comprised a base unit of size similar to the non-vertex, or hexons, but with a fiber 2 nm. wide and a 4 nm. diameter knob at the end. Length of the fiber was 20 nm. in the case studied, but this was later seen to be variable, depending upon the strain of virus under investigation (reviewed in Norrby, 1969).

Picornavirus

The picornaviruses number among the smallest known pathogens in the viral realm (Melnick et al., 1963). Perhaps due to their small size, some controversy exists over the morphological characteristics.

Base line data were presented in 1959 by Finch and Klug using X-ray diffraction techniques which indicated that polio virus did possess icosahedral symmetry, implying 60 n. protein sub units, with structure elements possibly spaced at 6 nm. The electron microscopic results, however have not been unanimous.

Horne and Nagington (1959), examining the three poliovirus types reported them to be composed of 5 nm. sub units, but could not resolve the number or arrangement. They did however report seeing occasional axes of fivefold symmetry and illustrate one such case in their plate VI. It can be noticed that their fivefold symmetry point is not occupied by a structure element, but is marked by a ring of 5 structure units in a pentagonal pattern. Despite this, later models to account for the morphology feature a structure unit at the 5-co-ordinated position.

A later study, that by Mayor (1964) which is much quoted as a description of picornavirus symmetry, describes findings which lead her to conclude that the number of sub units or capsomeres in the structure is 32 and that they are arranged on the 5-fold and 3-fold axes of a pentakis dodecahedron, a solid which is constructed in accordance with icosahedral symmetry requirements.

A later paper by R.M. Jamison (1969) agrees with Mayor's major findings, but prefers to consider the virus as built of capsomeres situated at the vertices of a rhombic triacontahedron, another variation in the icosahedral plan. The number of capsomeres and their co-ordination patterns however are the same as Mayor's and the latter feature includes a capsomere at the fivefold axis, in contrast to Horne and Nagington's proposal. The discrepancy between these models

resides solely in the nature of the geometrical solid favoured to best represent the structure. This latter distinction will in fact be removed if the complex solids are reduced to their corresponding icosahedron - both models are equivalent to an icosahedron with one capsomere on each of the fivefold vertices and one on each face. Since the respective complex solids are favoured because of preferred orientations of capsomeres noted in the E.M. which are compared with model analogues and their preferred orientations on a flat surface, there is probably little justification for their original proposal. In support of this conclusion, several arguments may be advanced: the surface of the grid is not liable to be as proportionately flat as a table top, nor will the virus have the plane faces of the models. Furthermore, if the virus adsorbs to the grid, the forces of attraction would add a further disparity between the two situations; in at least one case, that of adenovirus, there is definite evidence of capsomere proteins interacting in a specific manner with the grid (Norrby, 1969).

Breese et al. (1965) described a structure for foot and mouth disease virus consisting of 42 capsomeres situated on the twofold and fivefold axes of an icosahedron. Having estimated the number of capsomeres as probably either 32 or 42 in number, photographic rotations (Markham et al., 1963) were performed on models of these alternate configurations and compared to the same rotations done on a selected virus

micrograph. Somewhat better correlation was obtained between the 42 sub unit model and the virus particle illustrated. Agrawal (1966), using a similar approach, proposed that poliovirus was also composed of 42 capsomeres.

The existence of three separate models, all based upon selected particles, would imply either that the virus is variable in both the number of capsomeres and their co-ordination patterns, or, since that possibility is unlikely in the light of accepted structural principles, that at least several of the proposals are incorrect. Since all these studies are based primarily upon electron microscopic evidence, the choice between the alternatives is difficult. The most accepted structure appears to be that proposed by Mayor.

MATERIALS AND METHODS

A. Preparation of virus stocks

Lyophilized vaccinia virus (smallpox vaccine) from Connaught Laboratories was reconstituted with distilled water (1 c.c.); the resulting suspension was found suitable for negative staining and used in early studies. Subsequent stocks of this virus were prepared by inoculation of cell monolayers - a continuous line of rabbit kidney origin, R.K. 13 being maintained in this laboratory.

Monolayers showing advanced cytopathic effect, i.e. all cells either "rounded up" or detached, were frozen at -70°C along with the maintenance medium. On thawing, the medium with cell debris was spun in an International Model EN centrifuge at three-quarters of full speed for ten minutes to produce a "low speed pellet", and the supernatant fluid spun for 90 minutes at 97,000 x g to produce a "high speed pellet". The pellets were rinsed with a few drops of distilled water containing 0.05% of bovine albumin, and resuspended separately in just enough of this liquid to enable them to be pipetted.

The herpes simplex virus used in these studies was derived from the American Type Culture Collection's H.F. strain. Inoculation of cell cultures and harvest of high speed and low speed pellets were as described above.

Concentrates of influenza virus were prepared by differential centrifugation of infected allantoic fluid.

The virus used was obtained from the Defence Research Board's Shirley Bay laboratories, designated as influenza type A/PR8/32. Hundred-fold concentrated virus was suspended in PBS with 0.1% serum albumin.

Infected cultures of human foetal lung cells containing adenovirus type seven were obtained from the Ottawa Civic Hospital's Virus Diagnostic Laboratory. These cultures were processed in the same manner as those infected with vaccinia, above.

Echovirus type 9 was obtained as a concentrated suspension in phosphate buffered saline. Virus inoculum was supplied by the Canadian Communicable Disease Centre and subsequently passaged in primary African Green Monkey kidney cells. Concentration was by differential centrifugation, alternate cycles at 110,000 x g for 3 hrs. and 14,000 x g for 30 min. being used, after an initial clarification at 2000 x g for 30 min.

All stocks of virus and infected cell debris were stored at -70°C (influenza, herpes) or -20°C (vaccinia, adenovirus, echovirus) until required for use.

B. Preparation of support films for electron microscopy

Athene type, 400 Mesh, copper grids were used (E.F. Fullam, Inc., Schenectady, N.Y.). The support film was "Formvar" resin (E.F. Fullam) stabilized with spectrographic grade carbon by vacuum evaporation. The method used involved "glass casting" of the plastic on microscope slides from a

0.25% solution of Formvar in 1,2 dichloroethane followed by evaporated carbon stabilization and is essentially that described by Pease (1964). A thin plastic film was assured by withdrawing the glass slide slowly after dipping in the plastic solution contained in a wide mouthed glass jar so that excess solution was drained in an almost saturated atmosphere of solvent. Contrary to the observation by Pease, we have used Formvar solutions both freshly prepared and after storage of up to one and one-half years without any evidence of deterioration. Storage of the solution in our case was at room temperature in the dark, but the importance of these conditions is not known.

Evaporation of carbon was monitored by the oil-on porcelain method suggested in the above reference, the indicator being placed at approximately the same distance from the carbon source as were the grids to be stabilized. The amount of carbon deposited varied from just detectable levels to medium gray, the lighter grids being used for specimens where optimum resolution was required, the heavier ones for non-critical work as well as techniques which require strong films, e.g. Parsons' (1963) cell-spreading technique.

Ionic cleaning of the stabilized grids before use was essential to ensure good spreading of the virus-stain mixture when grids were prepared in one evaporator unit. Use of grids prepared in another unit obviated this difficulty,

but it is interesting to note that ionic treatment was successful where conventional techniques such as washing the grid with chloroform, or adding serum albumin or sucrose to the virus all failed, implying that the above technique is an extremely effective solution to difficult spreading problems.

C. Negative Stain

Phosphotungstic acid, neutralized after Brenner and Horne (1959) was used throughout. Either sodium or potassium hydroxides were used to neutralize the stain and pH values between 6.5 and 7.2 were used satisfactorily. This stain was chosen for exclusive use because of its proven applicability to a wide range of viruses.

D. Application of specimen to grids

Several methods of preparation were used, depending upon the nature of the virus-containing material:

Specimens of cell pellets were prepared by direct spreading on the surface of the negative stain (Parsons, 1963) with several preceding freeze and thaw cycles to disrupt the cells, making virus accessible to the stain (Horne and Nagington, 1959).

A second method was simply to freeze and thaw the pellet several times, place an aliquot on the grid, add a drop of stain and remove the excess material. This was repeated with one or two tenfold dilutions of the material in distilled water. Bovine albumin at 0.05% was added to the diluent to aid in spreading.

A third alternative was the droplet method as reported by Doane et al., (1969).

Virus pellets were treated according to the two latter methods, except for the freeze-thaw cycles which were not necessary. Parsons' method required more material than was usually present in these pellets, and thus was not used.

The general practice was to prepare grids by all of the methods which were applicable to the material under study, and to examine each under the E.M. All these methods, provided that they allowed for adequate dilution of salty material and/or the reduction of cell debris to an acceptable level, were capable of producing high quality specimens.

E. Electron Microscopy

Two instruments were used, a Hitachi HU-11C-1 and a Philips "EM 300". The Hitachi was operated at 75 KV with double condenser illumination and a 30 or 50 micron objective aperture at instrumental magnifications of 20,000 or 60,000. Photographic recording was done on Kodak Electron Image plates developed for minimum grain with HRP developer.

The E.M. 300 was operated at 60 or 80 KV using double condenser illumination and an objective aperture of 25 or 30 microns; instrumental magnification was varied according to the task and photographic system in use at the time. Photographic recording was by Kodak Fine Grain Positive 35 mm. film developed in D19, or Electron Image plates as above.

RESULTS AND DISCUSSION

Vaccinia virus was readily apparent both in the reconstituted vaccine and in the high and low speed pellets prepared from infected cell cultures. Particles typical of described "M" and "C" forms are illustrated in Fig.1. Demonstration of structure in the surface filaments of the M forms was dependent both on the quality of the specimens and on the microscopic conditions, a slight amount of defocus being required on the objective lens.

A small percentage of particles were seen which were approximately the size of mature virus, perhaps slightly smaller, but tended from rectangular to roundish in shape, with an irregular, electron dense central portion, surrounded by an irregular, wavy membrane. Other structures were seen similar to the above except that the central portion was uniformly electron dense and the structure was bounded by a simple, regular electron transparent layer. Both these types were judged to be immature particles or degraded virions, since they were not seen in control preparations, and are similar to the structures illustrated as internal components of this virus by Easterbrook (1966) and Mitchiner (1969).

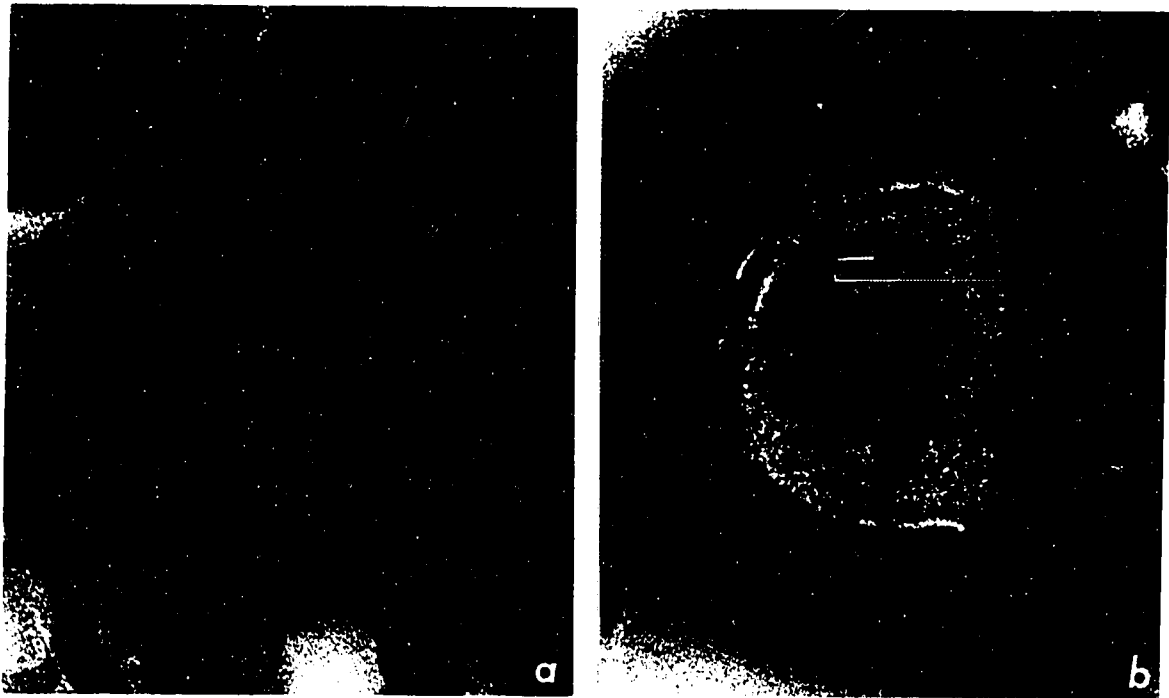

Fig.1 (a) Vaccinia Virus, M Form. Structure is seen in the surface filaments which is compatible with their being helical in nature (x 180,000). (b) C Form of the virus. Some detail of a pallisaded structure is visible in this picture (x 170,000).

Because of its large dimensions, this virus was readily discerned from among cell debris. Low instrumental magnifications could be used in scanning the grids, still enabling recognition of the size, shape and staining characteristics of this virus with some certainty. The difficulty usually posed by low concentrations of virus would be compensated by the ease of covering large areas of the grid when dealing with vaccinia.

Influenza: Morphology typical of the published descriptions was readily apparent in the preparations examined. In addition to the characteristic particles, large sac-like, electron dense forms were seen, and filaments of various lengths were also encountered. (Fig.2a).

An interesting particle is shown in Fig.2b, where a small spherical body in the preparation demonstrates an apparently geometric arrangement of surface spikes in contrast to the random appearance usually seen. Normal virions examined in this series occasionally display areas of regularity in surface detail, and arrays of small electron transparent objects appearing to be envelope spikes are commonly encountered in pseudoreplicas, (see pages 71-72) also arranged in a symmetrical pattern (Fig.2c). This pattern would seem to correspond to the hexagonal surface lattice proposed by Archetti et al. (1967) for influenza types A and A₂. It is possible that forces encountered in the drying down of a normal particle onto the E.M. grid

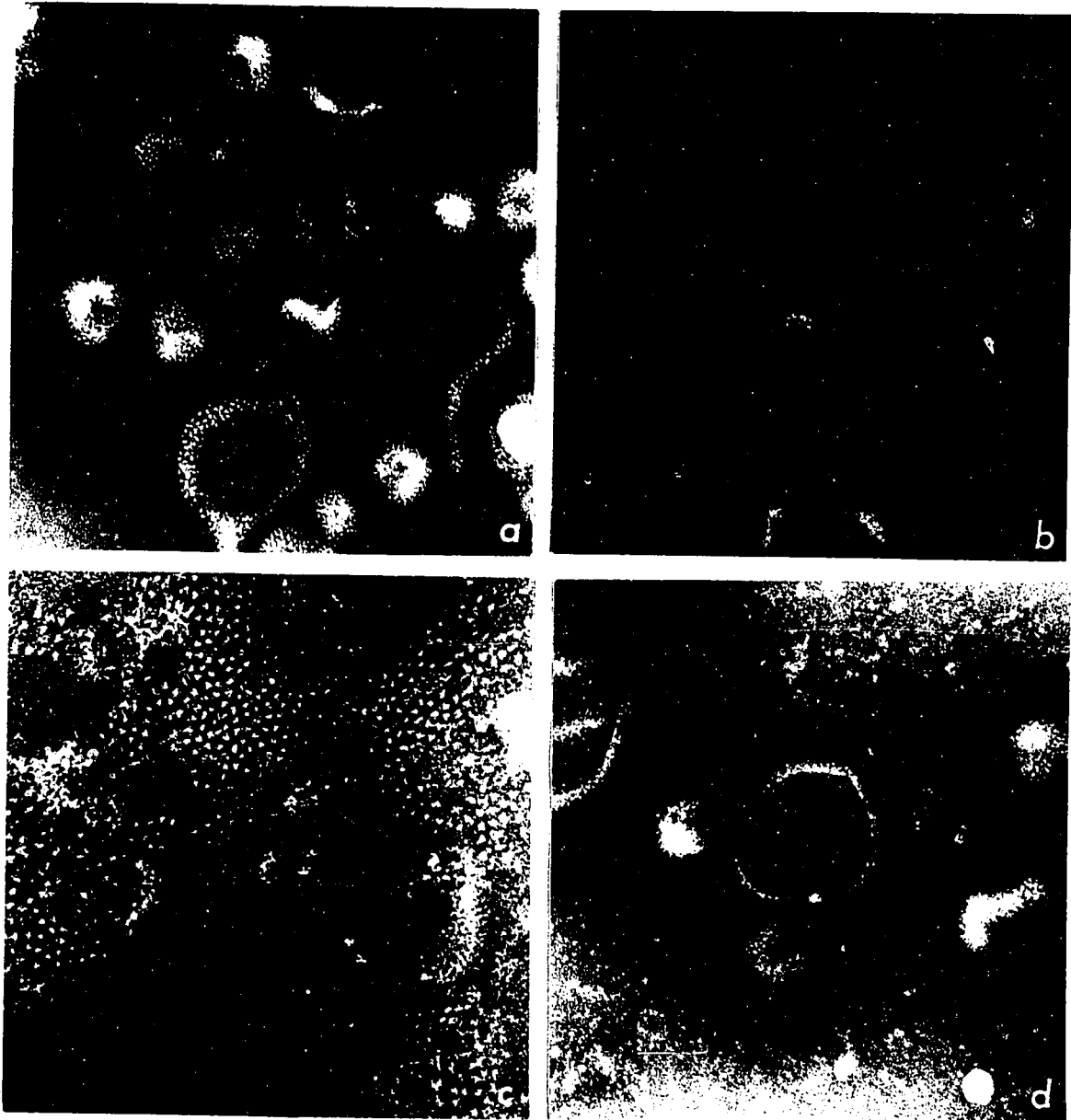

Fig.2.(a) Pleomorphic particles of influenza A/PR8, including distended and filamentous forms (x 85,000). (b) Particles with symmetric arrangement of surface projections (x 78,000). (c) Pseudoreplica of virus projections. Numerous areas showing hexagonal symmetry are seen (x 194,000). (d) Helical structures in a preparation of disrupted virus. The coils resemble a hollow tube (x 82,000).

lead to derangement of this basic pattern, but that the greater rigidity inherent in a small particle and the capture of the spikes in the plastic pseudoreplica are responsible for its preservation in the two examples shown.

Almeida and Waterson (1967) have also provided confirmation of the arrangement of the spikes in a hexagonal-pentagonal lattice based on selected observations of negatively stained material, but, more significantly, Nermut and Frank (1971) have reproduced this result, and, in addition, they provided supporting evidence from freeze-etch studies. Furthermore, they have evidence that the normal shape of the particle is icosahedral, a feature not shown when the virus is negatively stained, but revealed when freeze dried virus is studied by shadow-casting. Thus the envelope of the influenza viruses appears to be constructed according to an icosahedral plan, several types of evidence now corroborating this hypothesis.

The demonstration by Murphy and Coleman (1969) of a hexagonal framework in the envelope of an A2 strain, although seen in an abnormal particle, is yet another line of evidence to indicate that the envelope of these viruses possesses a basic hexagonal symmetry. This feature has been well established in the C strain for some time (Waterson et al., (1963), Archetti et al., (1967), Flewett and Apostolov, (1967) and has been held as a major difference between these and the A and B types (Apostolov and Flewett, 1969), but the presence of a

lattice structure in influenza A₂ would tend to reduce this difference to one of ease of demonstration. The other morphological difference proposed as separating types A and B from C by Archetti et al., (1967) is the distribution of spikes on the surface of the envelope (Fig.3). This proposal is disputed by Apostolov and Flewett, but the pictures produced to support their alternate hypothesis are not convincing, and the authors admit difficulty in resolving the pattern. Pseudo-replicates of influenza C might be informative in this respect.

Internal components of this virus were not seen in normal preparations of this virus although structures resembling supercoiled ribonucleoprotein were seen in amyl acetate treated virus (Fig.2d). Details of the treatment are presented in a later section.

Figure 4 illustrates the appearance of a normal virus preparation from two different areas of the same grid. The micrographs were taken within minutes of each other and are representative of the appearance of the virus over each of two large areas examined. Since the grid was prepared from a homogeneous suspension, we must assume that this effect was produced by local conditions on the grid during drying. While such drastic effects are not commonly noted, they were seen on several occasions, especially when the distribution of stain on the grid was not uniform. The figures are included

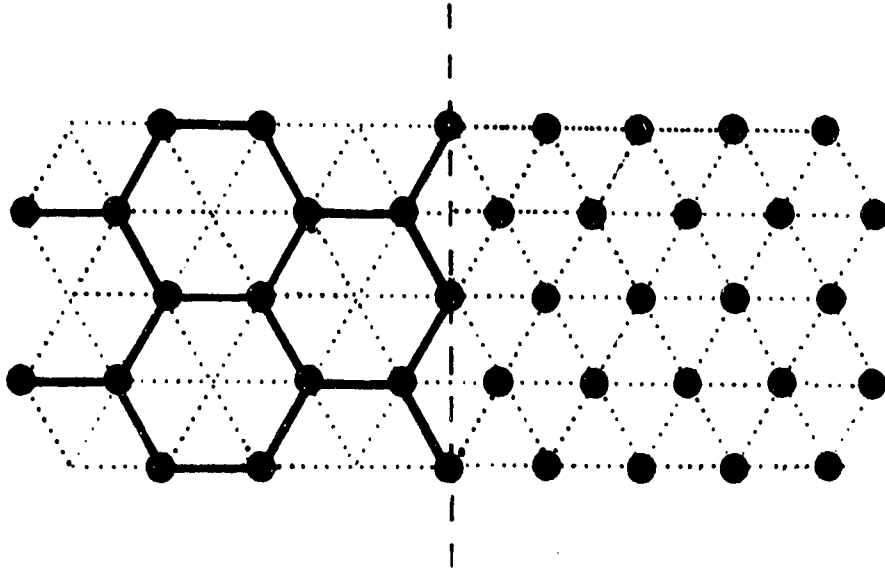

Fig.3. Arrangement of surface projections as proposed by Archetti et al.(1967) for influenza type C (left) and types A and B (right). Projections are indicated by solid circles on the diagram. In influenza C, a hexagonal lattice is seen connecting the bases of the spikes; this is indicated by the solid lines in the diagram.

here as a cautionary note towards interpretation of the effects of various treatments on viral morphology; good controls and reproducible results are an obvious necessity.

Herpes Simplex: Typical particles were seen comprising the many types described for this virus. Fig 5a illustrates an array of enveloped particles which are penetrated to various degrees with stain, while Fig. 5b demonstrates a range of penetration of the nucleocapsid. In addition, certain disrupted particles were seen, consisting of a group of free capsomeres and a spherical core which could be either "full" or "empty" (Fig. 5c).

All of the above particle morphologies are typical of the herpes group, and each would have diagnostic value to that level, with the possible exception of unpenetrated envelopes which do not reveal any detail of the nucleocapsid and may be confusing (Fig. 14). Watson (1968) has noted this occurrence, and has observed that wetting the grid with water, followed by redrying will cause penetration of these forms, revealing the internal details. In any case, Tyrrell and Almeida (1968) found these particles quite distinctive and presumably the rewetting technique could provide quick confirmation.

Adenovirus: The icosahedral array of capsomeres in the adenovirus capsid could be demonstrated in the phosphotungstate

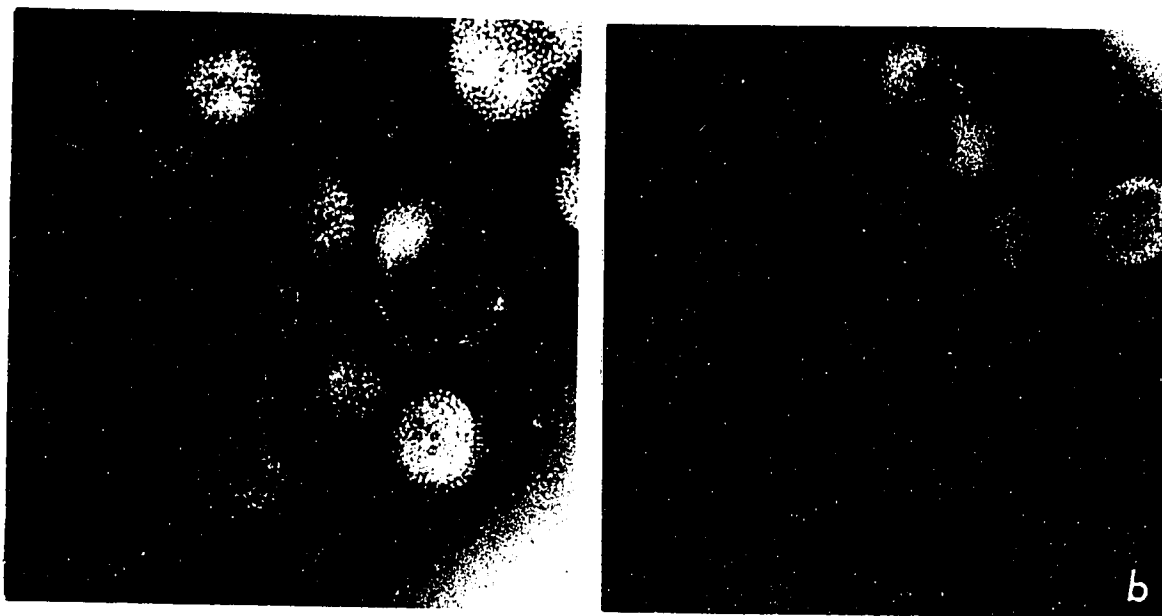

Fig.4. Influenza virus. Two pictures taken from the same grid. Morphological differences are due to local conditions on the grid during the drying of the specimen (x 98,000).

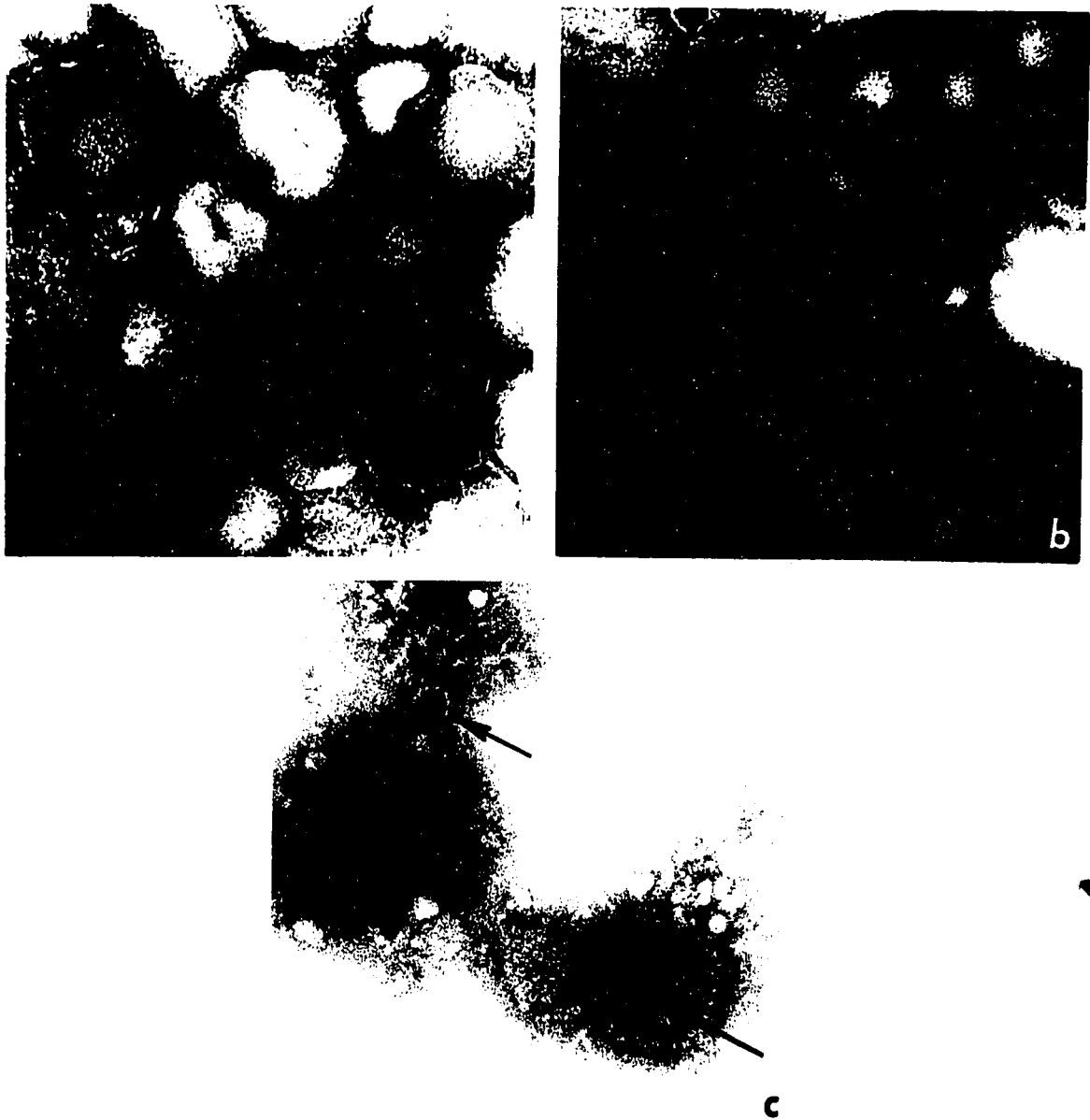

Fig.5. (a) Enveloped particles of herpes simplex; the envelopes have been penetrated to varying degrees to reveal the nucleocapsid (x 110,000). (b) Nucleocapsids variously penetrated. One particle at the top shows two envelope layers (x 89,000). (c) Disrupted nucleocapsid, and two "cores", one "full", the other "empty" (x 160,000).

stained preparations (Fig.6). In addition, closer inspection of the particles revealed indications of the knob at the end of the penton fibre. The lower particle in Fig.6a will serve as an illustration, knobs being visible beyond four of the vertices in this case. The complete structure demonstrating the relation between the capsomeres, fiber and knob as established by Valentine and Pereira (1965) was not seen in these preparations. This result was not unexpected since the work quoted, and later studies on adenovirus structure (Norrby, 1969) make use of silicotungstate negative staining, which seems the material of choice for this purpose. Although the fibers are not directly visible in these preparations, their length may be estimated by the knob-nearest vertex spacing.

Two distinctive types of sub viral components were also observed. Structures identical to the dodecons of Gelderblom et al. (1967) were seen, revealing the central cluster of penton bases, the fibers and the terminal knobs (Fig.6a). The presence of the dodecons in an E.M. specimen would not help in quantitation of the specimen, but since these structures are very distinctive and are characteristic of the adenoviruses, their detection would have qualitative, or diagnostic implications. The fact that fiber length correlates with Rosens sub groups (Norrby, 1969) could also

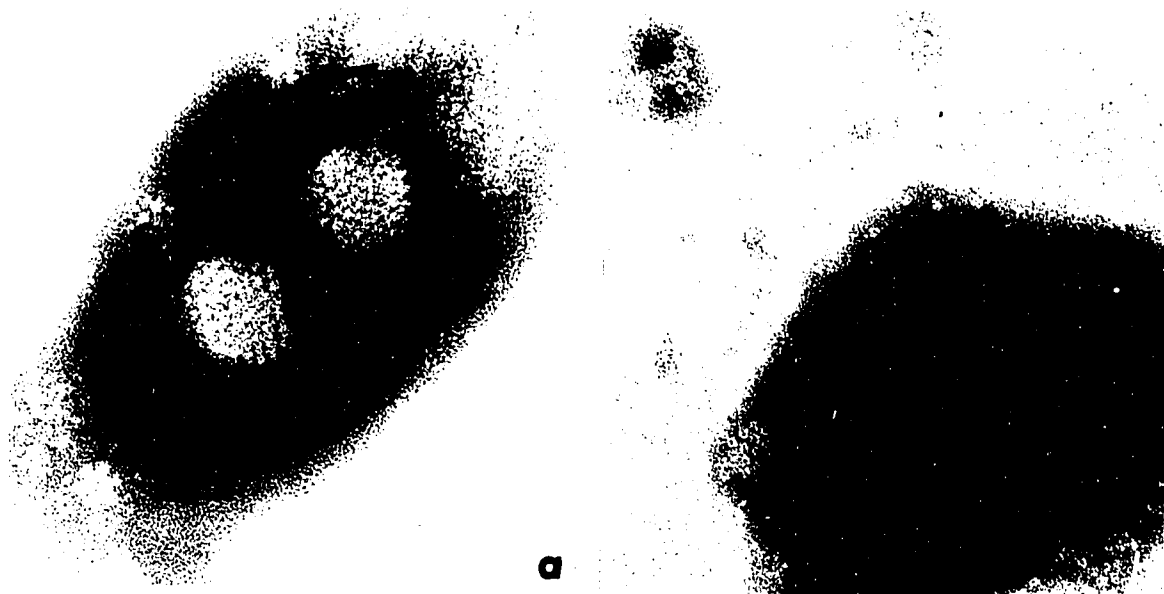

Fig.6. Adenovirus type 7. (a) Two complete virus particles. Icosahedral construction is evident in this picture; in addition, indications of the knobs on the penton capsomeres can be seen beyond several vertices of the lower particle. Two dodecons are present (arrows) (x 240,000). (b) Another group of viruses. Groups of 9 hexons can be seen as well (x 180,000).

be used to narrow the diagnosis since this parameter could be estimated from either the whole virus or from the dodecons.

Capsomeres were abundant in many preparations, occurring either singly or in groups. While the isolated capsomeres might be similar to those from disrupted herpes (Fig.5) or polyoma (Breedis et al., 1962), at least on cursory inspection, the groups of nine, which are generally arranged in counterclockwise fashion (Figs. 6b and 7) are characteristic of the adenoviruses. Since inversion of one arrangement would lead to the other, it is thought that one side of the hexon is preferentially adsorbed to the support film (Norrby, 1969).

Picornavirus: It was noted that structures of the type proposed by Mayor (1964) and Jamison (1969) could be demonstrated, but that the revelation thereof displayed a dependence on microscopic conditions to a degree not found with the other viruses in this series.

For example Fig. 8c shows a group of Echovirus type 9 close to instrumental focus, printed according to Mayor in reverse contrast; this is to be compared to Fig. 8a which is the same group, printed in similar fashion, but the original negative was obtained with the microscope six microns under focus. The latter picture shows several viruses which display dark "capsomere-like" areas arranged in a rhombus, however, note that the area surrounding the virus also shows these

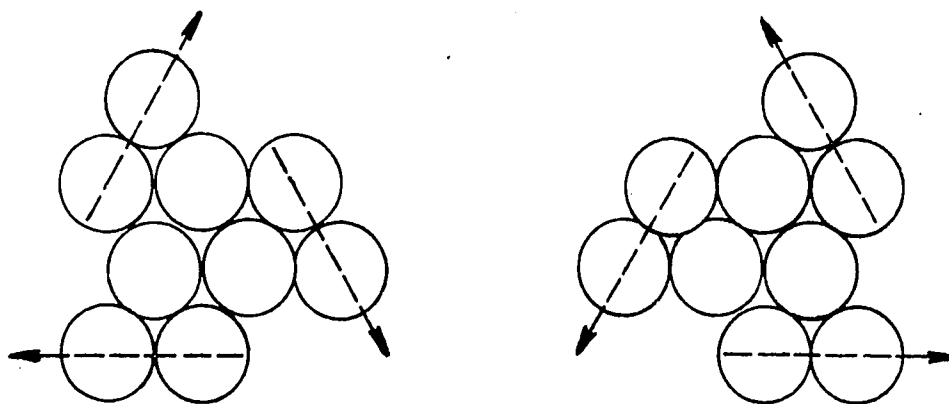

Fig.7. Groups of 9 hexons may be considered as consisting of a central triad surrounded by 3 pairs. These may be arranged in clockwise (left) or counterclockwise (right) fashion around the central 3. Note that inversion of one arrangement converts it to the other type.

dark spots, and that a series of virus sized circles placed in a row alongside the group includes several which also display a "central rhombus of capsomeres". The location of these circles was chosen without consideration of these details, simply by putting the end of a pencil on the picture, tracing a circle around it, moving down and repeating, until the six had been drawn.

The "capsomere" detail and its changes with conditions of focus resembles the behaviour of a support film in these circumstances, for example the series in Fig.9 demonstrates the apparent lack of structure at focus, with a granulation appearing with either over or under focussing. The average grain size varies in proportion to the degree of defocus; the specimen in this case is an evaporated carbon film with holes.

For comparison, consider Fig.10 which illustrates a herpes particle and some isolated capsomeres at conditions of instrumental focus and underfocus. The arrangement and size of the capsomeres can be seen in the focused picture although the defocused condition gives added contrast. In fact, this series demonstrates a loss of detail at the greatest degree of defocusing, and yet the total in that case is only two microns.

A further attempt to confirm the structure of this virus was done via the photographic rotation technique (Markham et al, 1963) using photographs of two particles taken at different degrees of defocus, both less than the six microns

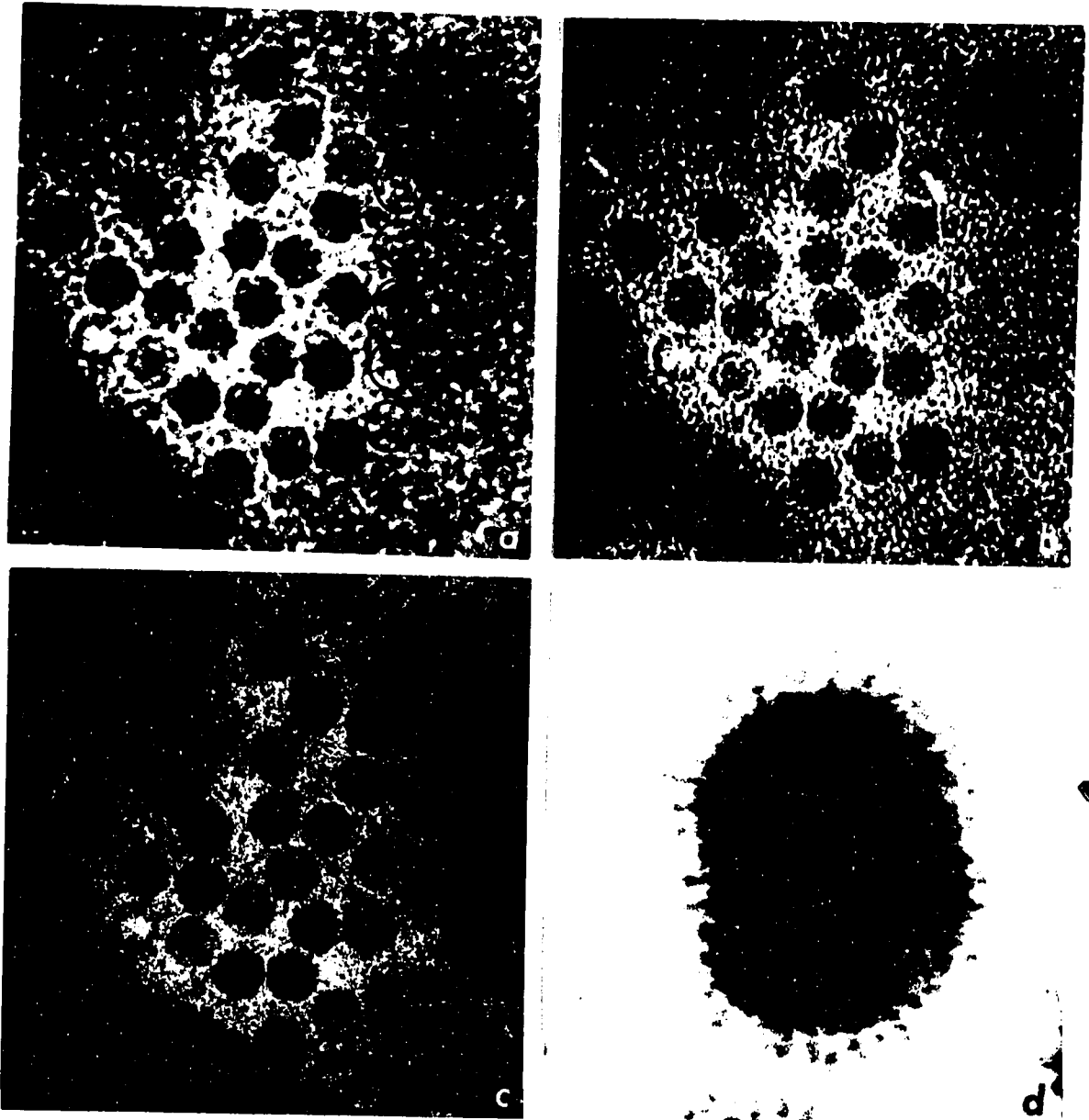

Fig.8. (a) Echovirus taken with microscope 6 microns underfocus. Note subunit structure of virus, similar structure in background. Six virus sized circles placed randomly on the background show two of their number with central rhombus of dark subunits. (b) Same group, microscope 3 underfocus. (c) Same group near focus. (d) Influenza virus printed in reverse contrast as are the above. Note that the spikes appear as dark areas.

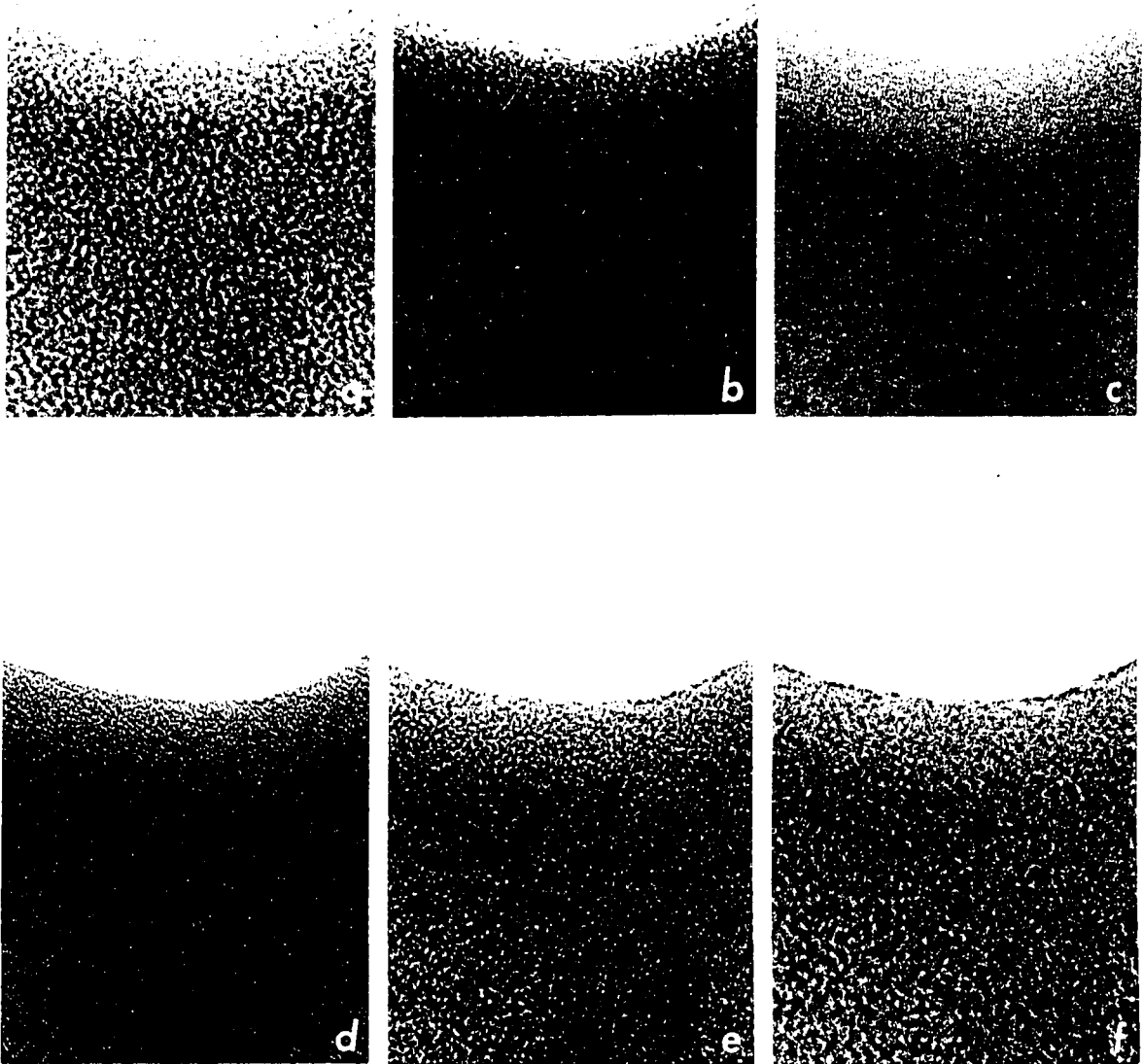

Fig. 9. Through focus series on the margin of a hole in a carbon supporting film. Granulation of the film can be seen to vary with the degree of defocussing. Grain over the hole is due to electron noise and photographic grain. (a) 7000A overfocus (b) 4000A overfocus (c) close to focus-slightly under (d) 2000A underfocus (e) 4000A underfocus (f) 7000A underfocus.

used in Fig. 8 but of the order of that used in routine virus microscopy (the exact defocus is unknown for these pictures but can be qualitatively evaluated from the granulation of the background). Rotations of 360° were done in divisions of $360^\circ/n$ at appropriate partial exposures to produce the series in Fig. 11. Nothing resembling reinforced viral symmetry was seen; some odd shaped element does appear in several of the pictures, but is suggestive of an artifact generated by the technique rather than viral structure.

In any case, no elements corresponding to the putative structure were reinforced. Both particles were well preserved with respect to displaying hexagonal outlines. This feature would be seen in particles constructed according to Mayor's model which were lying in their preferred orientation.

An infrequent observation is presented in Fig. 10d where an "empty", partially disrupted particle is apparently constructed from sub units which could correspond to the peripheral capsomeres seen in the "empty" particles of many viruses. This substructure could be recognized from a close to focus (possibly slightly overfocused) picture and throughout a series extending to two microns underfocus in 0.4 micron steps. The separation of the sub units is difficult to measure, and the particle is not entire, but 40-50A can be estimated.

In summation, the demonstration of the reported morphology of the picornaviruses is uniquely dependent on

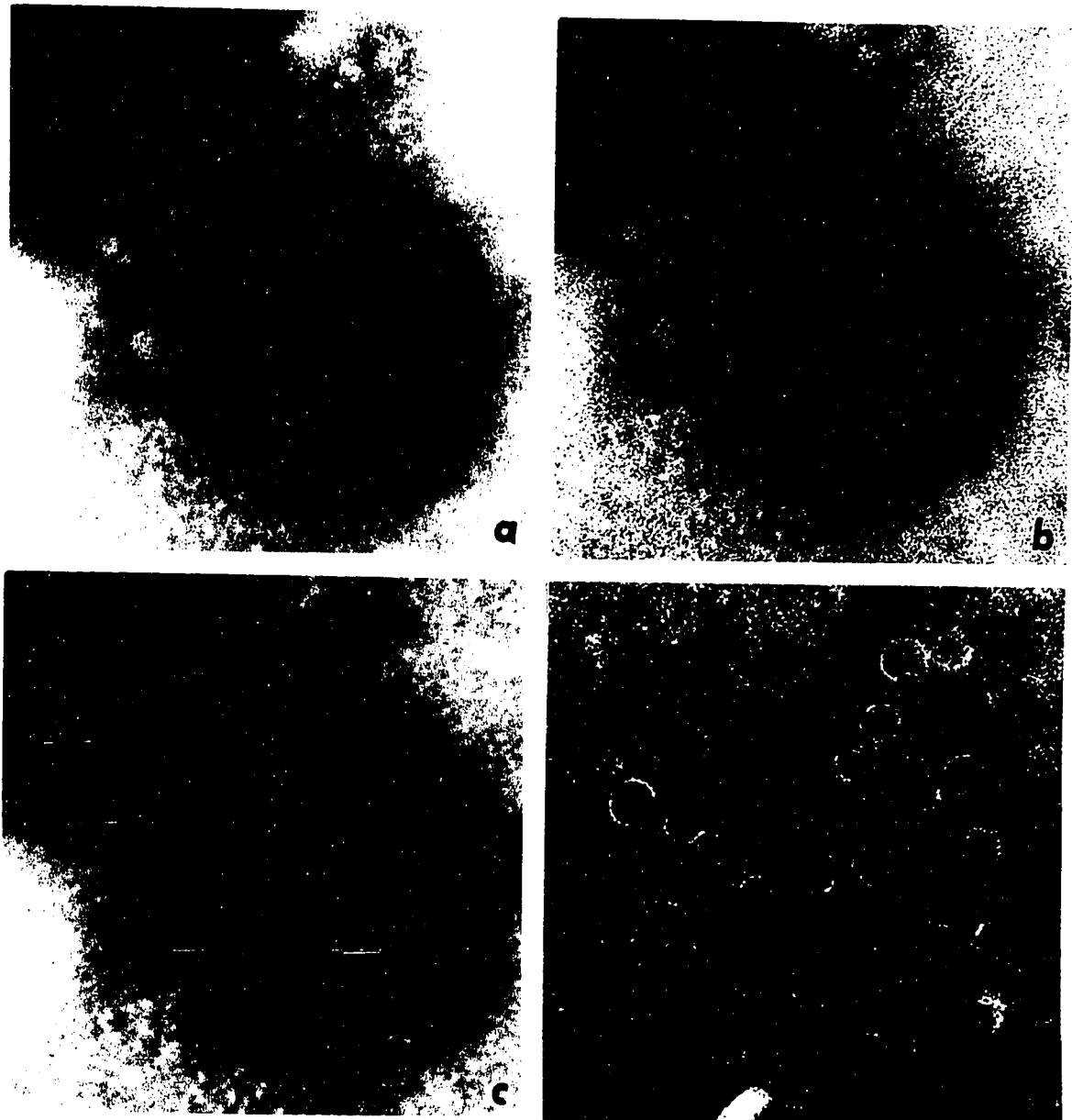

Fig.10. (a)-(c) Herpes simplex and isolated capsomeres taken at close to instrumental focus, 1 micron and 2 microns underfocus respectively. Note the apparent gain in contrast with slight defocus and the loss with further underfocussing (x 200,000). (d) Poliovirus, "empty" particles. Note the disrupted shell with beaded appearance at centre, left (x 180,000).

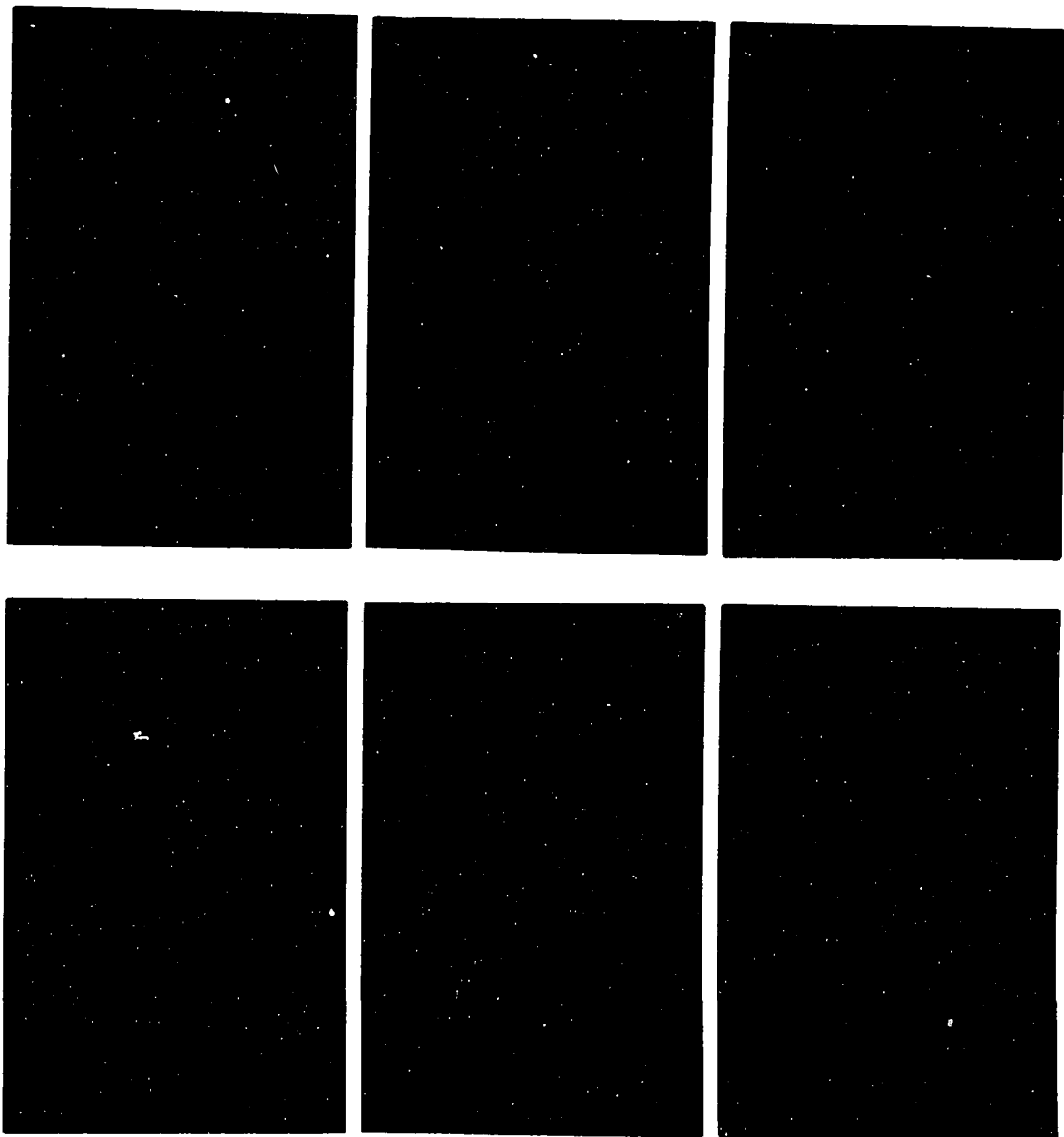

Fig.11. Photographic rotations of a single particle at $360^\circ/n$. The hexagonal outline is reinforced at $n=2,3$ and 6 as expected, but no surface detail is revealed. (a) unrotated (b) $n=2$ (c) $n=3$ (d) $n=4$ (e) $n=5$ (f) $n=6$.

large degrees of underfocus in the electron microscope. Examination of the micrographs published in support of the various structures proposed for this group suggests that these analyses were done on particles photographed under similar conditions, as indicated by granulation in the background of the same order of magnitude as the "capsomere" detail on the particles. It is suggested that inability to resolve the phase image of the substrate from object structure detail may account for the conflict in results obtained by the various groups. Since the grain size of the defocus substrate image varies with the actual focus used, the differing capsomere numbers may correlate with the instrumental conditions used. Similarly, since details compatible with known principles of virus construction were observed only on selected particles and with acknowledged difficulty, it is possible that the random structure in the phase image may have been selected in favourable configurations coincident with the location of virus particles.

While it is acknowledged that a slight amount of defocus aids in the observation of detail in biological specimens (Johnson, 1968, Sjostrand, 1967, Haydon, 1969^b, Parsons, 1970) the same authors caution that any proposed biological structure must have a periodicity demonstrably different from the phase contrast granularity of the background produced by defocusing. In this context, the latter effect

has been shown to simulate ferritin substructure (Chescoe and Agar, 1966) as well as to suggest small sub units in the molecule of arginine decarboxylase (Haydon, 1969 b). Since defocus phase contrast enhances the contrast of intrinsic features as well as imposing spurious patterns, the morphology reported may indeed be representative of the structure of these viruses, but we are forced to conclude that such has not been demonstrated.

The fact remains, however, that focus-independent substructure can occasionally be seen in empty particles, which suggests that these viruses are constructed of typical capsomeres (Fig. 10d; Svehag and Bloth, 1967, Fig. VI), but the number and arrangement cannot be assigned on this basis alone. A recent proposal on the architecture of the picornaviruses is based entirely on biochemical data. Dunker and Rueckert (1971) arrive at a structure from consideration of the numbers and types of proteins found in the capsid and capsid fragments. When these data are considered in relation to the requirements of icosahedral symmetry, the authors propose that the capsid is composed of 60 chemical sub units, an interesting correlation with the original X-ray diffraction data. Electron microscopic evidence in support of this model can also be quoted (as in the case of the other models), since Horne and Nagington's (1959) observation on poliovirus revealed a co-ordination pattern at the 5-fold vertex identical

to that proposed by Dunker and Reukert, that is, the 5-fold axis is not occupied by a structure unit.

In practice, then, the E.M. cannot be expected to resolve a distinctive capsomere pattern on the picornaviruses, and therefore this feature cannot be used as a diagnostic aid. Other criteria that might be of value include size and shape, but the size has been reported for this group in a fairly large range of 17-30 nm. and the shape may be either round or hexagonal in outline. Since we have commonly encountered round, electron transparent areas of the above sizes, and struggled with their identity whilst searching for low concentrations of picornaviruses we must conclude that this combination of size and shape is an unreliable guide to the presence of these viruses, since any small globule which excludes stain is liable to be confused with viruses. On the other hand, hexagonal bodies of appropriate size might have diagnostic significance, but this is not a constant feature of the virus in the E.M. "Empty" particles constitute yet a third class, but again are simulated by certain structures in some preparations we have observed.

Contrary to the conclusion that the task is impossible, numbers of bodies displaying some of the above combinations of size, shape and staining characteristics have been observed in virus preparations leaving no doubt in the operator's mind that virus was being observed, however this was based upon

the accumulation of evidence over a number of possible sightings, compared with experience in preparations not containing virus. As the concentration of virus on the grid increases, so does one's confidence in making a judgment; the large numbers per field or the clumps of virus one sees in a purified preparation are definitely unique to viral material, but at the other end of the scale the picture is not so clear - thus the lowest concentration which is detectable will be determined to a large extent by variations in the specimen and by operator variables.

Before leaving the problem of picornavirus morphology, we would like to make several proposals on a general level. The demonstration of capsomere structure has been seen to be equivocal, and yet from biochemical data and X-ray diffraction studies we can assume that the virus is constructed of sub units according to an icosahedral plan. By analogy with other viruses, we expect resolvable capsomeres in the E.M. by negative staining - yet this has not been done in satisfactory fashion.

One possible explanation for this failing may be that the virus is composed of a large number of small capsomeres. This solution would be allowed by both the X-ray data and the polypeptide composition of the virus capsid, although it does go against the trend to lower capsomere numbers in the smaller viruses. However, this situation should not in itself preclude resolution of the arrangement in the E.M. since calculations may be made which reveal that two to three hundred capsomeres

could be accommodated on a shell the size of this virus without requiring capsomere diameters less than 1.5 nm., and Bradley (1967) has demonstrated that negative staining can be used to resolve structures at 1.5 nm. Therefore high capsomere numbers should still be resolvable under ideal conditions.

Another possibility which suggests itself is that structural proteins which make up the shell are not well separated from each other, leaving little room between for the penetration of the negative stain necessary for the development of contrast in the electron image (Fig.12). The situation might be further compounded by the small size of the capsomeres or by their arrangement in a skew lattice, which would prevent superimposition reinforcement of detail from both sides of the negatively stained particle, and introduce confusing patterns by this same mechanism. This latter arrangement hampered the solution of structure of the papova group for some years (Finch & Klug, 1965).

Solution to these problems might come from several directions. If the proposed structure visible at underfocus were indeed a true one, at least for many of the particles seen, statistical evaluation of the patterns with respect to the background and the proposed structure might give a confirmation - problems expected here are knowing the probabilities of various orientations of the particle which

may not be based on geometry but affinity of the virus for the grid, as well as the difficulty of being able to separate particles showing real structure from those not doing so. In the case of vaccinia virus where the demonstration of beaded substructure in the surface filaments seems also to depend on precise defocus (Westwood J.C.N., personal communication) the regularity of this feature in the filaments distinguishes it from the randomness of the similar sized granularity of the background (see Westwood et al., 1964).

If skew lattice construction is a contributing factor to the confusion, the separation of the two sides of the image might help. Approaches to this problem have been made variously, both by stereoscopy (Finch and Klug, 1965) and by special staining techniques (Anderer et al., 1967, Nagington et al., 1964) although both these might be difficult to apply in this case where capsomere cannot be differentiated from artifact at the outset.

A third possibility lies with a technique not utilizing negative stain, namely freeze etching, which is suggested because it has shown itself capable of resolving capsomere structure in at least one case where negative stain was unsuccessful (Bayer and Remsen 1970). A detailed study by this means might be similarly productive in this case, and because of a greater intrinsic contrast in this type of specimen, the degree of defocus could be considerably less,

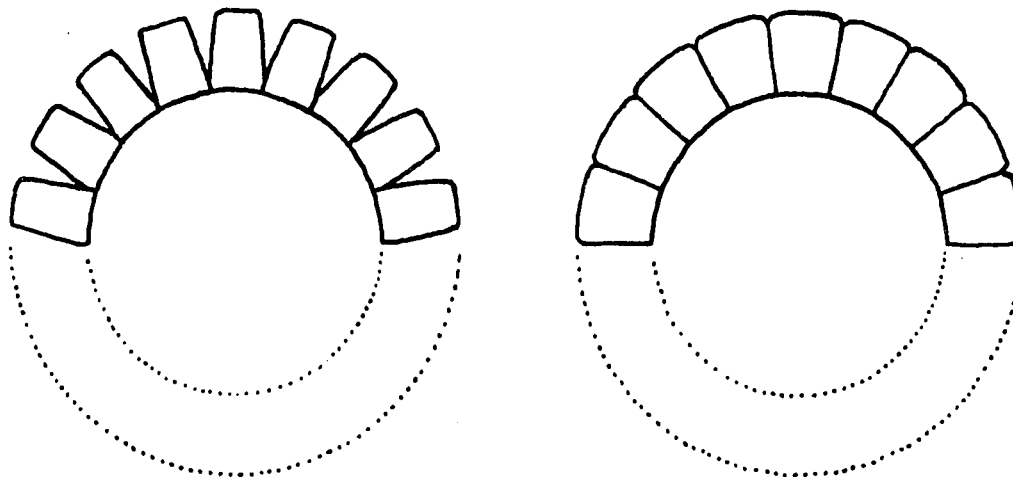

Fig.12. Two types of construction from subunits. The close packed arrangement on the right would be very difficult to resolve, whereas the separation between neighbouring units at left would allow penetration of stain.

circumventing entirely this major source of confusion.

It is also possible that the range of sizes quoted is overestimated due to instrumental and operator variables incurred when compiling results from various laboratories. Contributions to the error obtained with negatively stained specimens can also be due to staining conditions due to embedding in varying thicknesses of electron-opaque stain (Kerridge et al., 1962). Noteworthy in this context, however is a series done in one laboratory where two size classes were found in a large sampling of picornaviruses (Jamison and Mayor, 1966).

QUANTITATIVE STUDIES

The sedimentation counting method (Sharp, 1949) was considered to have the greatest potential for the detection of airborne virus, primarily because of its intrinsic concentration factor which might permit direct quantitative detection of virus in air sampler effluent fluid without intermediate concentration steps. Modification of the original technique to allow sedimentation of the virus onto an agar disc followed by pseudoreplication (Sharp et al., 1952) was the variation chosen for use because it permitted counting of virus in "salty" solutions and could be used with negative staining techniques (Rhim et al., 1961).

The suggestion by Smith and Melnick (1962) that suspensions could be centrifuged in any "swing out" head of an ultracentrifuge was extended to available equipment, and from a full tube of suspension, the calculated sensitivity of this technique seemed impressive (Appendix I). Consideration of relevant data on airborne infection and on virus particle to infective unit ratios implied that this technique might permit direct examination of sampler fluid, permitting rapid diagnosis with a minimum of manipulation.

It was thought that this level of sensitivity must be demonstrated to confirm the calculations and eliminate

aberrant behaviour of the viruses during sedimentation or subsequent manipulations. The technique had not been used extensively, but Sharp (1960) had reported non-quantitative pseudoreplication for meningopneumonitis "virus" and Muller and Neilsen (1970) had mentioned systematic errors present in the technique, so it was deemed advisable in this and any subsequent study to ensure that the virus did behave as expected.

Accordingly, we proposed the determination of virus concentration in comparison with at least one other method which involves different procedures, choosing the microdrop spray method of Williams and Backus (1949) using polystyrene latex (PSL) indicator particles, since it entailed the counting of entire aliquots of the virus suspension which are produced by shearing of columns of liquid (Dimmick, 1969), a mechanism expected to provide representative samples of the suspension. Incorporation of phosphotungstate into spraying fluid (Watson, 1962) permits the counting of virus showing typical morphology as described above.

This test appears to be very reliable for obtaining particle counts and a study by Breese and Trautman (1960) indicates that sample size need not be large to obtain accurate counts and that the ratio of test (virus) to indicator (PSL) particles may deviate markedly from unity without serious effect on the accuracy obtainable. Major sources of error to

be expected arise from clumping of one or both particle types or interaction between the two classes of particle - these effects can be monitored before use for the particles involved, as well as being observable in the actual preparation being counted.

If good correlation could be observed between these methods, demonstration of direct, linear correlation of virus counts by sedimentation with dilution of the original sample would represent a further check on systematic errors and imply that our calculated sensitivity could be attained in practice.

MATERIALS AND METHODS

Spray Droplet Technique

The apparatus used was essentially that described by Horne and Nagington (1959), constructed using materials at hand. The wash bottle and reservoir were not found necessary, and gas-tightness of the system could be checked for major leaks by the characteristics of the flame. Virus concentrates in distilled water were used, mixed with 2% phosphotungstate, $10^{-2}\%$ of 0.126 micron diameter polystyrene latex spheres and 1% bovine albumin at ratios of 2:2:2:1.

Spraying was carried out in the apparatus described, 20 to 30 "puffs" having been determined empirically to produce a large number of countable droplets on the grid without much interference from overlapping. The grids used were carbon-stabilized formvar as described in the preceding section.

After the spraying operation, the stopper in the charging port of the nebulizer was slowly removed, permitting air under the influence of negative pressure generated by the burner to sweep out the interior of the apparatus. After several minutes of purging, the slide containing the grids was removed and the grids examined in the electron microscope. The apparatus was decontaminated by immersion in disinfectant between uses.

Virus concentrations were determined by counting virus particles and polystyrene latex spheres in the electron microscope. The computed ratio of virus particles/latex spheres, multiplied by the known concentration of PSL (Appendix II) gives the particle count per milliliter. Only droplets that could be counted in their entirety were examined to preclude non-random distributions from influencing the count.

Sedimentation counting

The method used is detailed in the references given above; briefly, virus in suspension is centrifuged onto a flat agar receiving surface at the bottom of the container. When sedimentation is complete, the supernatant is removed and discarded. The receiving surface, a flat agar disc, is removed from the centrifuge tube and allowed to dry. Drying occurs by withdrawal of the suspending fluid into the agar block, leaving the particles on the surface; the presence of salts in the liquid

phase does not interfere since the solution is not evaporated to dryness, the salty solution rather being imbibed by the agar. When the surface appears dry, a solution of Parlodion in amyl acetate is poured on, the excess drained off and this film allowed to dry. Upon completion of drying, the plastic film is floated off the agar block onto a solution of negative stain, carrying the sedimented virus particles with it, forming a so-called "pseudoreplica" of the receiving surface. The pseudoreplica can then be mounted on grids and examined in the electron microscope. Virus can thus be recognized and counted over known areas of the film and the concentration of virus in the original suspension derived by reference to the sedimentation geometry.

In these experiments, sedimentation was done in either a SW 25.2 rotor in a Beckman-Spinco type L2-50 ultracentrifuge, or, later, a type SW-41 rotor for the same instrument. The geometry for the latter rotor is essentially the same as the first except for smaller tube diameters.

Sedimentation times for the viruses under study were calculated for the SW 25.2 rotor operating at a speed of 22,500 r.p.m. (Appendix III). In practice, this time was usually exceeded by 30-50% and timing was done from start-up.

The agar surface generally used is prepared from a two percent solution, however, under the conditions described above, discs of this composition tended to break up. Blocks

of six or ten percent agar (S.P., Fisher Scientific Co.) were found satisfactory, although the six percent was easier to work with and solidified to a smoother surface. For these reasons, 6% agar was used in this study.

The sedimentation cell was prepared using a standard cellulose nitrate tube as specified for the rotor in use; tubes in their buckets were suspended in a water bath near boiling, and sufficient molten agar was added to fill the curvature in the bottom of the tube. Five ml. was required for each 25.2 rotor tube, 0.7 ml. for the SW-41 tubes. The buckets were immediately closed, attached to the rotor and spun at 6000 rpm for 20-30 minutes until cooled; this procedure ensures that the plug of agar will set without a meniscus, which, if present, would interfere with the fitting of the agar disc (see Appendix, Fig A-1).

Agar discs, of the same diameter as the internal diameter of the centrifuge tube to which they were to be fitted, were cut from a Petri plate containing the appropriate thickness of gel. One disc was placed in each tube, resting on the hardened agar plug in its bottom. This disc was used as the virus receiving surface since it was easily removed and handled during subsequent manipulation. To achieve the sedimentation geometry used in the calculations, a 2 mm. thickness was used in the SW-25.2 tubes, while 4 mm. was used in those for the SW-41.

Erratic, low counts were encountered in several early

runs using this system and the error was traced to the above preparative procedure. It was noticed that in adding the molten agar to the tubes by touching the pipette to the side, a thin layer of agar remained as a streak on the inside wall. When this tube was later used in high speed centrifugation of virus suspensions, the agar streak became detached from the tube wall and was spun down onto the agar disc to cover some portion of its surface. When the supernatant fluid was pipetted off, this film, and the virus which was deposited upon it, was often removed; thus the following pseudoreplica was not representative of the sample.

This problem was avoided by pipetting directly into the bottom of the tube, or else, having pipetted down the side, the tubes were filled with distilled water and allowed to stand several minutes, after which the streak of agar was easily detached from the tube wall and the plug and it could be removed from the tube. The agar disc was then placed on top of the plug and the rest of the procedure carried out as usual. A carefully made perspex plug could be substituted for the agar as a more permanent solution.

The composition of the cellulose nitrate solution used for pseudoreplication was found to be of critical importance for the successful use of this technique. Unsuitable preparations of the plastic would result in films which were unstable in the electron beam, forming holes and tearing when irradiated

in the microscope. Best results were obtained using a commercial (E.F. Fullam) preparation of 1% nitrocellulose in purified amyl acetate. Attempts to substitute Formvar in ethylene dichloride were made which resulted in stable films, but virus particles were not retained in the pseudoreplica.

Some degree of film instability was encountered using the commercial nitrocellulose, but could be controlled by several means. Introducing the specimen into the microscope and gradually increasing the illumination starting from a highly defocussed condenser, was found to be effective. By this means, replicas which would "squirm" and tear when introduced into a focussed beam could be successfully stabilized. Evaporation of a thin layer of carbon onto the completed pseudoreplicate will of course provide the needed stabilization, and this approach may be used provided the additional time required for this treatment does not offset the advantage gained.

For ease in mounting of pseudoreplicated specimens onto E.M. grids, the following procedure was found convenient. The agar receiving surface, which had been coated with the plastic solution was cut into grid sized squares. The film was then floated off the agar block onto the surface of the stain by careful submersion of the agar at a small angle and a grid was placed on top of the floating film. The assembly was then grasped with a fine tipped forceps and pushed beneath the surface, inverted, and removed from the liquid with the plastic film preceding the grid. Done in this manner, the surface tension

pressed the film to the grid as it was removed from the phosphotungstate solution, whereas attempting to simply pick up the floating film and grid directly from the surface usually resulted in the film folding or detaching from the grid. After removal from the stain, the grid was blotted with filter paper and allowed to air dry.

Virus suspensions to be counted were prepared by making serial dilutions of the sample used for spray droplet counting; determinations by these two methods were made at the same time so as to be representative of the sample at that time. Virus concentrations were calculated from counts obtained over known areas as described in Appendix I.

RESULTS AND DISCUSSION

The results reported below are of a preliminary nature, since sufficient replicates were not done for rigorous statistical analysis, however, several qualitative conclusions can be drawn from these data and the magnitude of probable deviations judged.

Vaccinia, prepared as described in the previous section, had a noted tendency to aggregation on thawing. Sonication of the suspension immediately before use at an intensity observed to produce good cavitation for 20 seconds in a small vial resulted in suspensions which appeared largely free from aggregates when viewed in the E.M. The polystyrene latex similarly was mostly monodisperse, but several small aggregates were observed from time to time with both materials.

Serial tenfold dilutions of the virus suspension were

prepared and one ml. of each was added to 10 ml. of diluent in a prepared cell numbered accordingly. Expected concentrations were calculated from the average ratio of virus to PSL obtained in the spray droplet grids (Table III). Results could be obtained showing both good agreement and linear decline with dilution, but earlier series were characterized by erratic counts, preparations from a single cell giving calculated concentrations either as expected or values much below those predicted. Large, abrupt variations were encountered between different areas on the same grid. This variation in results ceased once the procedure had been modified to include removal of the agar residue on the tube wall (see Materials and Methods).

One observation that was made during these counts was that while grids prepared by mixing of virus and stain showed the virus to be 70-90% in the morphological "M" class, the virus examined on the pseudoreplicates was almost entirely in "C" form. Since treatment of the virus with lipid solvents has been shown to have a similar effect on the virus, it is assumed that the amyl acetate in the plastic solution is destroying the integrity of the virus coat, permitting penetration of phosphotungstate. Some "core"-like bodies are also seen in these preparations, (Fig.13c), but their appearance is not so dramatic as the conversion noted above.

A series of grids of contagious pustular dermatitis virus (orf) demonstrated a similar result. The standard method of grid preparation showed two forms equivalent to the "M" and

TABLE IIICOUNTS ON VACCINIA VIRUSA. Spray Droplet

Concentration of PSL	$9.1 \times 10^{10}/\text{ml.}$
Number of PSL spheres	697
Number of virus particles (VP)	94
Number of droplets	42
Ratio (VP/PSL)	0.135
Concentration of virus	$1.23 \times 10^{10}/\text{ml.}$

B. Sedimentation

<u>Dilution</u>	<u>Number of Viruses</u>	<u>Expected Concentration</u>	<u>Observed Concentration</u>	<u>Deviation (%)</u>
9.1×10^{-3}	TNTC ¹	$1.12 \times 10^8/\text{ml.}$	-	-
9.1×10^{-4}	648	$1.12 \times 10^7/\text{ml.}$	$1.13 \times 10^7/\text{ml.}$	0.9
9.1×10^{-5}	568	$1.12 \times 10^6/\text{ml.}$	$1.06 \times 10^6/\text{ml.}$	5.4
9.1×10^{-6}	125	$1.12 \times 10^5/\text{ml.}$	$1.04 \times 10^5/\text{ml.}$	7.1

1. The virus on this grid was so concentrated as to have many viruses superimposed, making counting unreliable.

"C" types of vaccinia, except that the "C" form usually retained some indications of surface structure (Fig.13a) - the pseudoreplicate preparations on the other hand revealed only a "C" type structure which was entirely devoid of any surface detail (Fig.13b). Of hundreds of particles examined, this type was the only one seen.

In any case, good agreement between the two counting methods can be attained, and the linearity of count with dilution is evident.

The procedures used for herpes simplex were as those used for vaccinia, except that sonication was not necessary, vigorous pipetting of the solution being sufficient to produce a suspension that appeared homogeneous to the eye and in the E.M.

The correlation between counts in this case (Table IV) is not as good as in the previous, the reason not being known at this time, however the counts again show reasonable linearity of count with dilution, at least for the dilutions in which a significant number of particles were counted. Unpenetrated, enveloped virus was present in the spray droplet preparations, up to one-quarter of the virus being in this form. These enveloped particles were quite uniform in size, possessed an irregular fringe and tended to be hexagonal in shape. Many were partially penetrated by phosphotungstate (Fig.14).

A freshly prepared concentrate of influenza virus was



Fig.13. (a) Orf virus, negatively stained on the grid. Types corresponding to "M" and "C" are shown, but the arrangement of surface threads is faintly visible in the "C" particle (x 100,000). (b) Orf from a pseudoreplicate, surface details are absent (x 100,000). (c) Vaccinia from a pseudoreplicate. Virus is almost entirely in "C" form as shown. Several core-like bodies are also shown. (x 98,000).

TABLE IVCOUNTS ON HERPES VIRUSA. Spray Droplet

Concentration of PSL	9.1x10 ¹⁰ /ml.
Number of PSL spheres	151
Number of virus particles (VP)	115
Number of droplets	7
Ratio (VP/PSL)	0.76
Concentration of virus/ml.	6.93x10 ¹⁰ /ml.

B. Sedimentation

<u>Dilution</u>	<u>Number of Viruses</u>	<u>Expected Concentration</u>	<u>Observed Concentration</u>	<u>Deviation (%)</u>
8.3x10 ⁻⁴	804	5.73x10 ⁷ /ml.	7.45x10 ⁷ /ml.	30
8.3x10 ⁻⁵	186	5.73x10 ⁶ /ml.	8.28x10 ⁶ /ml.	45
8.3x10 ⁻⁶	177	5.73x10 ⁵ /ml.	6.35x10 ⁵ /ml.	11
8.3x10 ⁻⁷	9	5.73x10 ⁴ /ml.	4.72x10 ⁴ /ml.	18

used to set up parallel counts by the two test methods. Spray droplet preparations showed a number of particles which were appropriate size and shape to be considered virus, but did not show the characteristic surface structure. These were not counted as virus and may be related to the virus-like shapes reported by Hoyle et al. (1961), but their presence necessitated close inspection of particles to be counted.

Cells were prepared as for the two previous viruses, containing influenza virus in concentrations calculated to be from 6.6×10^8 /ml. to 6.6×10^3 /ml. After sedimentation, pseudoreplication and staining we were unable to obtain counts from this material, since some of the grids revealed nothing recognizable as influenza virus, while others contained what appeared to be virus in varying states of degradation from nearly complete virus to amorphous debris, (Fig.15).

Pseudoreplicates were prepared from virus which had been placed on agar surfaces, and control grids were made by direct application of virus and stain to a pre-filmed grid; again the virus was morphologically normal in the controls while the pseudoreplicates showed only disrupted material.

Virus suspension and amyl acetate were mixed in equal proportions in a test tube and incubated at room temperature; grids were prepared from an untreated aliquot of the virus suspension and from the virus-solvent mixture after one minute and twenty minutes. Morphologically normal virus was found in

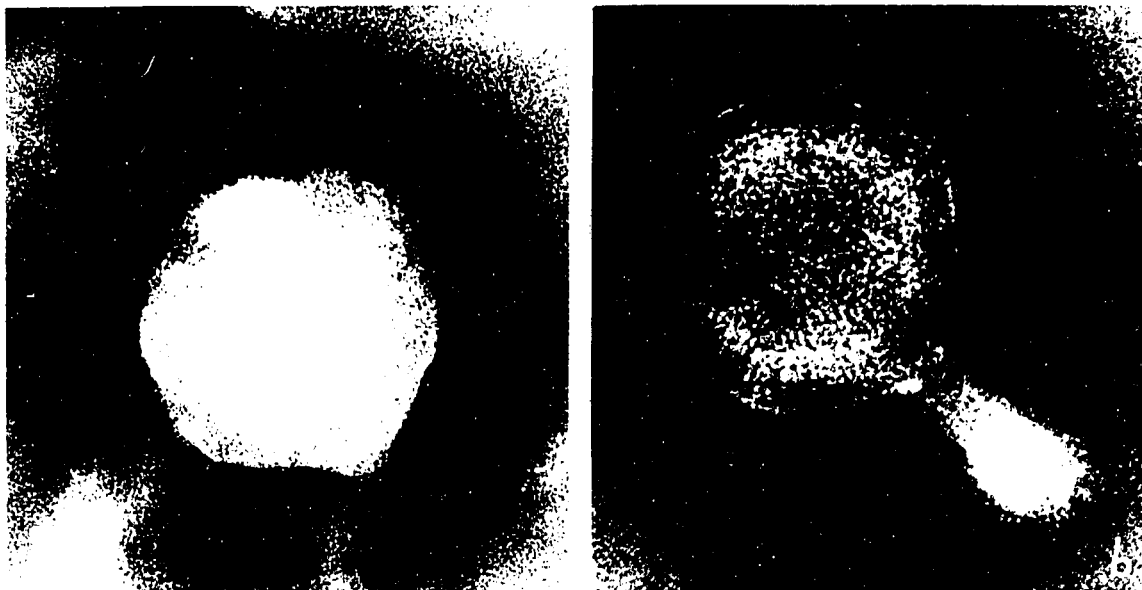

Fig. 14. Enveloped herpes particles from a spray-droplet preparation. These particles are characteristically compact and roughly hexagonal, with an indistinct fringe. In addition to unpenetrated (a) and partially penetrated (b) particles, there is a majority of particles revealing details of the nucleocapsid (x 270,000).

TABLE VCOUNTS ON INFLUENZA VIRUSA. Spray Droplet

Concentration of PSL	$9.1 \times 10^{10} / \text{ml.}$
Number of PSL Spheres	270
Number of virus particles (VP)	215
Number of droplets	5
Ratio (VP/PSL)	0.796
Concentration of virus/ml.	$7.2 \times 10^{10} / \text{ml.}$

B. Sedimentation (See text)

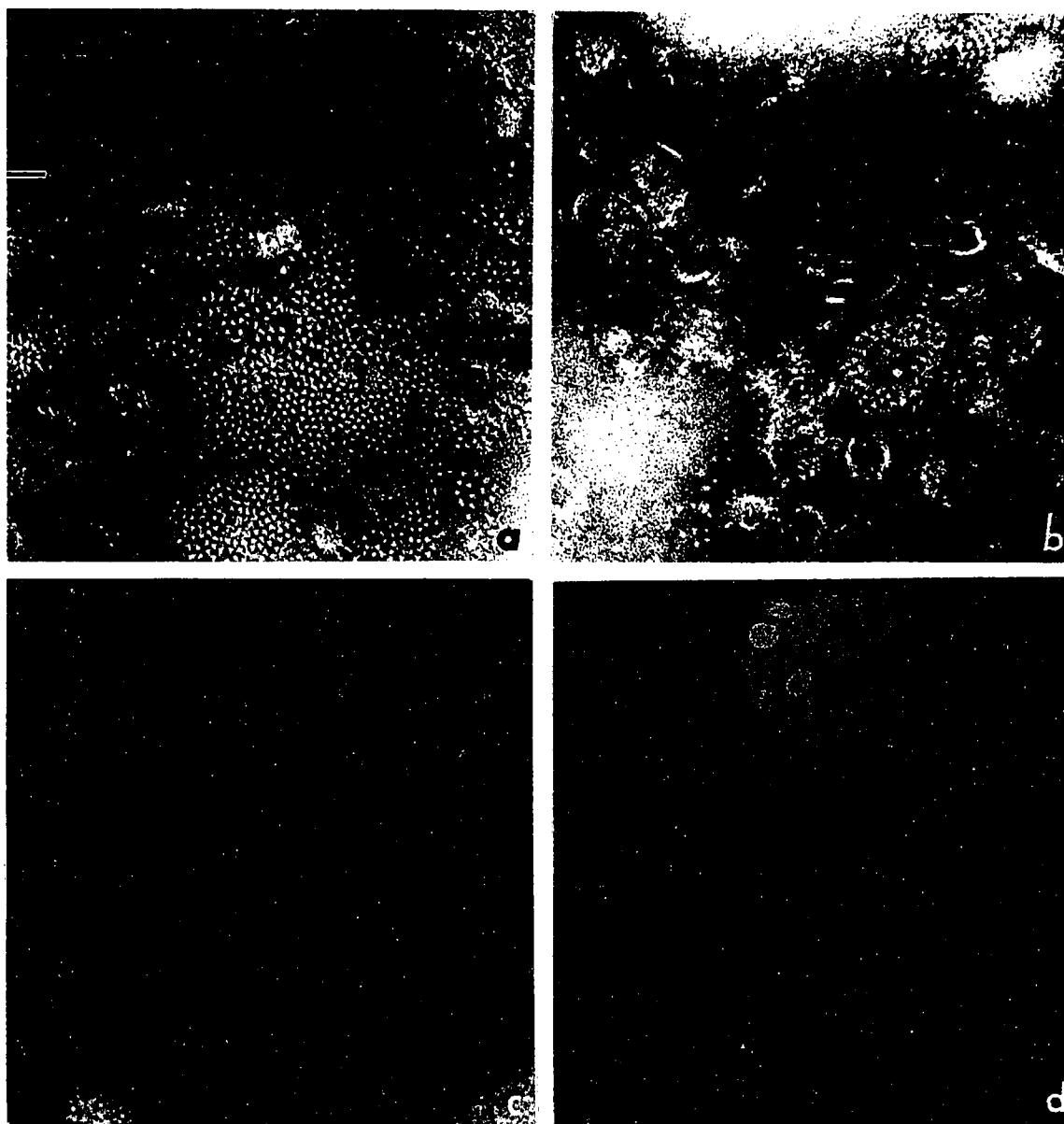

Fig.15. (a) Pseudoreplica from influenza virus preparation. Disrupted membrane, internal component, membrane spikes and amorphous debris may be seen (x 130,000). (b) Amylose acetate treated virus. Note similarity to previous picture (x 145,000) (c) Early pseudoreplica with normal virus (x 160,000). (d) Another grid in same series where disruption is more evident (x 80,000).

the control preparation, but virus disruption was evident in the solvent treated material after one minute of incubation, and was more extensive after twenty minutes (Fig 15b). Some relatively normal particles could be found in both these acetate treated specimens.

These destructive alterations in virus morphology are typical of those described by early workers using lipid solvents such as ether for virus disruption (Hoyle et al., 1961) and since we have demonstrated that amyl acetate can duplicate these effects, we feel justified in attributing at least the major portion of the disruption found in pseudoreplicates to the contact of virus with the plastic solvent.

The major difference in the virus seen after treatment versus that in pseudoreplicates is the presence of some whole virus in the former, even after twenty minutes of treatment, while in the latter case, although the solvent has evaporated in one or two minutes, the destruction is essentially complete. Considering the fact that during pseudoreplication, naked virus on the surface of the agar comes into contact with essentially pure solvent, while in the test tube experiment the virus encounters droplets in an emulsion - a hit and miss contact situation, we do not find these results seriously in conflict. There is conflict however with earlier results obtained in sedimentation counting attempts where this virus was pseudo-replicated in a manner which seemed satisfactory at that time (Fig.15c). Although plagued with film instability in that

series, estimates of virus concentration from these attempts, when compared with titrated infectivity of that preparation, indicated a particle to egg infective unit ratio of twenty, a number similar to reported values (Isaacs, 1957). Retrospective examination of those micrographs does show some evidence of virus disruption, but the overall appearance and the numerical relationship above still suggest that counts might be obtained by this method.

The nitrocellulose used in the above work was collodion at 0.7%; when comparing 2% solutions of this plastic and the Parlodion now used, there is a marked difference in viscosity between the two, Parlodion being much thicker. Possibly the less viscous solution allowed better drainage of excess solution from the pseudoreplicated surface and faster evaporation of solvent, keeping contact conditions below those required for extensive disruption. If true, returning to that plastic, or to a solution of Parlodion which is just strong enough to produce a complete film might enable quantitative recovery of the virus. The instability of these films in the electron beam might be overcome, as suggested by Smith and Melnick (1962) by the over-disposition of a thin layer of carbon in an evaporator unit before examination.

Alternatively, fixation of the virus on the agar block before pseudoreplication might allow quantitative studies. We have not attempted to confirm this possibility as yet.

Results on adenovirus and a picornavirus are still forthcoming but we have found that both these viruses will pseudoreplicate. The adenovirus preparation did show a high proportion of subviral components, however, but the specimen was merely a crude cell lysate and thus liable to contain components not incorporated into mature virus. Direct examination of this material also showed both mature virus forms and subviral components, but detailed comparisons between the two situations were not made to determine whether the pseudoreplication had a deleterious effect on the virus. Since adenovirus is not particularly sensitive to lipid solvents and the mechanical forces involved in the procedure do not disrupt other viruses, we would expect pseudoreplication to be innocuous in this case, but this contention is unsupported.

GENERAL DISCUSSION

The proposal for the application of electron microscopy to the detection of airborne viruses is supported by the results reported here, with several important exceptions.

The fact that negative staining has been used successfully with a wide range of specimens and will demonstrate typical viral morphology in even very crude material has obvious implications in any diagnostic application - the proposal for detection of airborne virus is an extension of this valid principle. The findings with respect to the picornaviruses, however, tend to unseat this principle, especially with low concentrations of virus. This may not be too serious a finding for the diagnostic field, but is liable to provide for problems when examining material near the limit detectable in the E.M. Contrast this situation with the finding of a single adenovirus particle, where no doubt would remain as to the nature of the structure, and one might even be able to assign the sighting to a serological subgroup; in the former case one might be able to report a particle resembling a small virus, provided the specimen was free from artifacts which might confuse the operator.

In a work recently completed (Chaudhary et al., 1971) it was hoped that reaction of this virus with antibody would

produce a complex which was distinctive in the E.M. Unfortunately, this was not always the case, although occasional results were encouraging - perhaps some variation in the staining techniques could make this feature reproducible and thus provide a means for confirmation of a possible sighting. If virus-antibody mixtures do not prove sufficient, ferritin labelled antibody, or the hybrid antibody system of Hammerling et al., (1969) are fascinating alternatives, enabling one to label the unknown virus with a visual marker; in the latter case this could be a distinctive object such as an adenovirus. It must be borne in mind, though, that these techniques are increasingly complex and expensive, but by use of a two-stage system (grid treated with antiserum, marker conjugated to anti-serum antibody) one might find it feasible.

It would be appropriate also to mention here that it is an oversimplification to regard our proposal as a direct extension of diagnostic electron microscopy. In that case, one has presumably a patient and clinical condition to which one may refer findings, whereas this may not always be the case when examining air sampler effluents, depending on the particular application being attempted at the time. The literature on viral structure has revealed that human viruses have morphological counterparts in the pathogens of other vertebrates, lower animals and even plants. The air, of course, is subject to contamination from all these sources, and it may be that cultural confirmation of any sightings will be a necessity. In that case, valuable

data on virus type and concentration could still be obtained by electron microscopy.

Pseudoreplication was noted to destroy the morphological integrity of influenza virus, except that under certain, as yet undefined conditions, reasonable preservation of this feature could be accomplished. Unless these conditions can indeed be specified, it will be necessary to exclude this virus from those to which this technique may be applied. By extension, we would assume that this restriction will also apply to the paramyxoviruses, and since vaccinia virus also showed some change, we must express caution when dealing with any virus sensitive to lipid solvents. Since herpes can be successfully treated in this fashion, no rule can be made at this time.

The concept of direct treatment of air sampler material to give numbers and kind of airborne virus is an attractive proposition, and the results we obtained may be taken as confirming the sensitivity of the technique proposed in this study. Relating this figure to data on airborne virus has indicated that we might be able to detect virus under conditions of aerosol spread, but there is little latitude in the performance. For example, if any one of the factors influencing the VP/IU ratio were to seriously reduce its value, we would be able only to diagnose unrealistically high concentrations. On the other hand, the effect of aerosolization and storage in aerosol on viral morphology is completely unknown. Since biological instability may be quite high, it is definitely of value to

proceed with studies to examine this relationship, including data on large volume air sampling in this context.

Alternate methods of specimen preparation for the electron microscope may produce some increase in sensitivity in virus detection, but the improvement is not expected to be large. Consider the following example: if one takes 120 ml. of fluid as obtained by Gerone et al. (1966) from a 10 minute air sample and concentrates it to a 0.1 ml. volume, one will be forced to rely on a drop method of preparation. Pinteric and Taylor describe their method as being useful to concentrations as low as 5×10^7 particles per ml. with poliovirus, perhaps lower with larger viruses. If in fact this could be extended to 10^6 /ml., one could obtain a 20-fold improvement over direct sedimentation - at the quoted level of performance no advantage would be gained.

Re-evaluation of the entire program must then be made in the light of all the above findings and it is suggested that any further development of this technique be made in the context of a particular application.

Already we have noted that VP/IU data varies from virus to virus, aerosol stability is similarly variable, so that quantitative considerations may be increasingly disparate, requiring different sensitivities, and therefore different approaches. Pseudoreplication has been shown to further separate the viruses, and the interference from background material will depend to a great extent on the environment in which the samples were taken.

SUMMARY

Recent years have seen the expenditure of much effort in obtaining experimental evidence of airborne transmission of virus diseases to corroborate epidemiological findings which have been accumulating for many years. Progress has been rewarding, but the isolation of airborne virus has been the aspect of these studies which provides continuing difficulty; procedures now in use are time consuming, expensive and do not display a high success rate.

Extending a trend in the area of diagnostic virology, it was proposed that direct electron microscopy of air sampler material might be capable of providing a rapid diagnosis at greatly reduced effort. Calculations confirmed that a method might be evolved which could be of use in the light of known characteristics and data from airborne infection studies. An experimental plan was formulated to bear out the calculations and test the assumptions upon which these were based.

Results obtained to date indicate that the calculations are sound and that calculated sensitivity can be achieved, but that the morphology of one of the test group of viruses is not well established and inadequate as a diagnostic criterion at the lower limit of sensitivity. Limitations in the technique chosen have also been established regarding its applicability to certain viruses. Suggestions have been made in these two areas and proposals for future work outlined.

The study reported herein is being continued under a grant from the Defense Research Board of Canada.

APPENDIX I

A. Calculation of volume correction factor for S.W.25.2 rotor

When the cell is prepared with an agar plug, which is in turn overlaid with a disc of agar as a receiving surface, the critical dimensions of the apparatus are as follows:

Distance from center of rotation to surface of liquid (cm)	6.7
Distance from center of rotation to surface of agar (cm)	13.9
Distance from surface of liquid to surface of agar (cm)	7.2

Due to the nature of the sedimentation forces, particles will migrate in the cell to a given area so as to sweep out a volume which is shaped as a truncated wedge, or trapezoidal solid (Fig.A₂).

The volume originally containing the particles deposited upon the given area could be calculated simply, assuming the solid to be rectangular, by multiplying the area by the height of the liquid ($r_2 - r_1$), however the solid actually involved is trapezoidal in nature and a correction factor must be applied which considers the volume ratio between the two solids.

With reference to figure A₂, the volume of the rectangular solid based on a given area would be represented by:

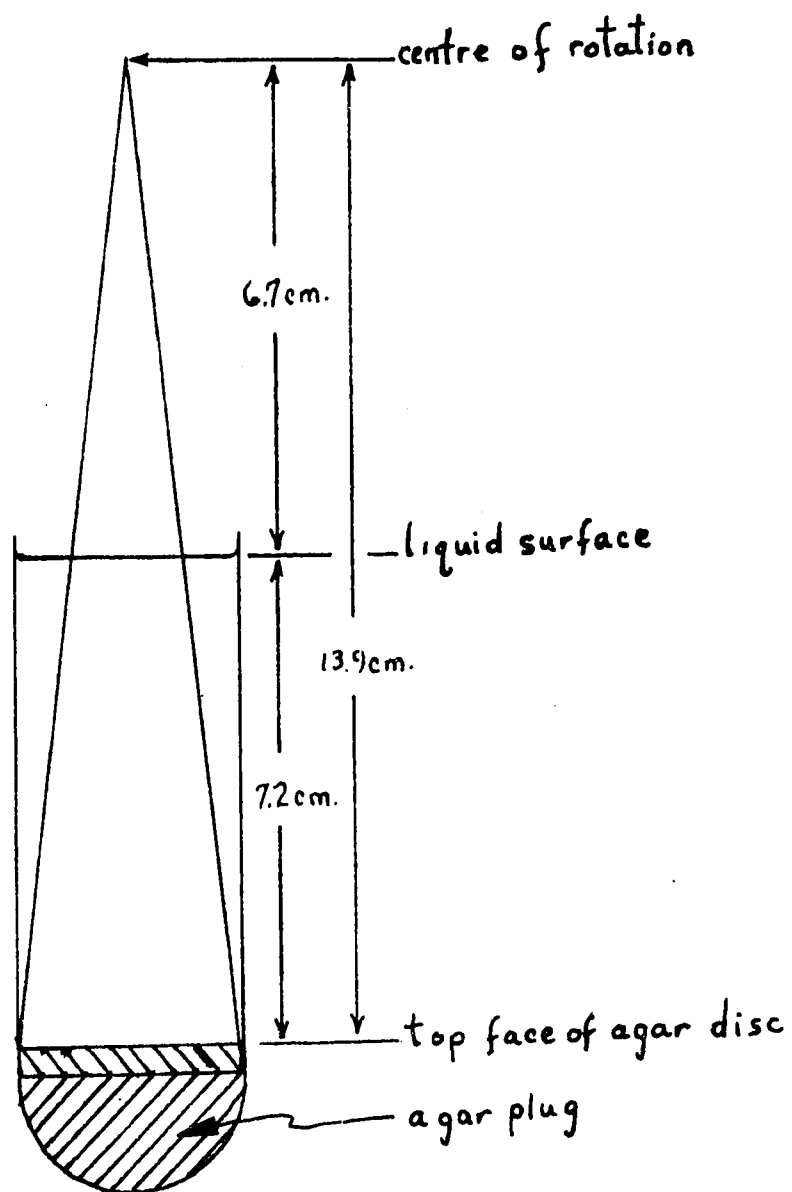

Fig. A1. Sedimentation cell used for virus counts.
Presented as seen from the axis of rotation.

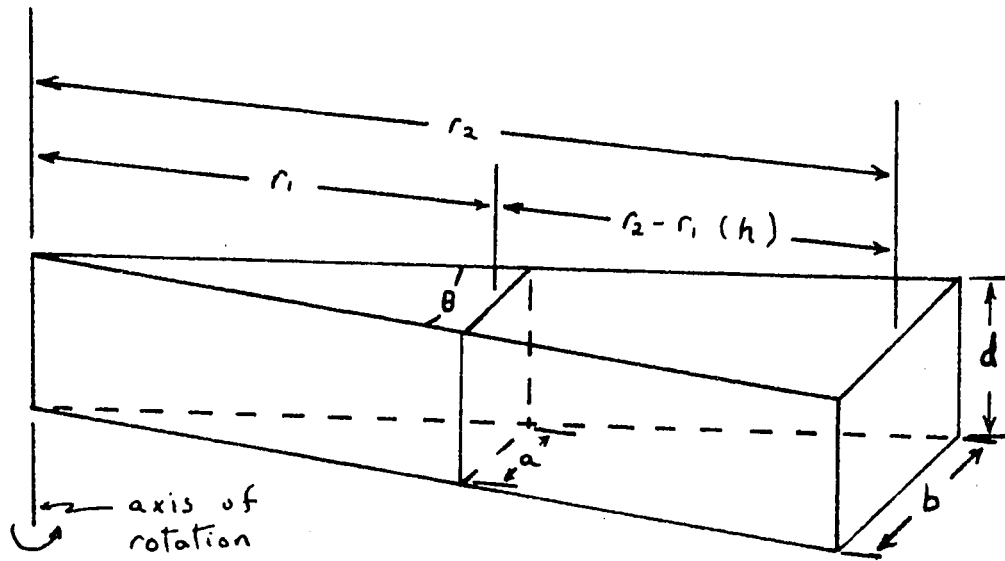

Fig.A2. Sedimentation pattern in a centrifugal field.

$$\text{Vol.}_r = b \times h \times d \quad (1)$$

Since the length of the chord subtending an angle Θ is given by the relation $2 r \sin \frac{1}{2} \Theta$, equation (1) may be written:

$$\text{Vol.}_r = 2r_2 \sin \frac{1}{2} \Theta (r_2 - r_1) d \quad (2)$$

The volume of the trapezoidal solid will be similarly given by:

$$\text{Vol.}_t = \frac{1}{2}(a + b) \times h \times d \quad (3)$$

which, by the same conversion applied to (1) above, becomes:

$$\text{Vol.}_t = \frac{1}{2} (2r_1 \sin \frac{1}{2} \Theta + 2r_2 \sin \frac{1}{2} \Theta)(r_2 - r_1) d \quad (4)$$

Simplifying, we have:

$$\text{Vol.}_t = \sin \frac{1}{2} \Theta (r_1 + r_2)(r_2 - r_1) d \quad (5)$$

The volume correction factor could thus be written:

$$\frac{\text{Vol.}_t}{\text{Vol.}_r} = \frac{\sin \frac{1}{2} \Theta (r_1 + r_2)(r_2 - r_1) d}{2r_2 \sin \frac{1}{2} \Theta (r_2 - r_1) d} \quad (6)$$

which again simplifies to:

$$\text{Factor} = \frac{r_1 + r_2}{2r_2} \quad (7)$$

Thus, the correction factor is dependent only on the parameters r_1 and r_2 which are constant in our experimental system, being 6.7 and 13.9 cm. respectively. Solving for this factor in equation (7), we have:

$$\begin{aligned} \frac{r_1 + r_2}{2r_2} &= \frac{6.7 + 13.9}{2(13.9)} \\ &= 0.73 \end{aligned}$$

The volume of liquid containing the particles counted over a given area may therefore be computed simply by multiplying the area by the height of liquid, to get the volume of the rectangular solid, then multiplying this figure by the correction factor of 0.73 which will adjust the volume to that of the corresponding trapezoidal solid.

As a consequence of the pattern of migration, since we are using a cylindrical cell, we will have losses to the walls of the tube (27% of the total virus), which will be maximal on the sides perpendicular to the plane of rotation. Since this virus will eventually migrate down the wall to the agar disc, its edges must be avoided when preparing grids so as not to get spuriously high counts.

B. Concentration giving one virus particle per square

The grids used on this study are Athene type, 400 mesh copper, obtained from E.F. Fullam, Inc. By measurement with a calibrated filar micrometer eyepiece fitted to a B & L Stereozoom microscope, the open area of each hole was found quite uniform and of an average of 27.2 microns square. In the cell described above, the volume contributing particles to an area of film 27 microns square would be given by:

$$\begin{aligned} \text{Volume (cm.}^3) &= (2.7 \times 10^{-3})^2 \times 7.2 \times 0.73 \\ &= 3.83 \times 10^{-5} \text{ cm}^3 \end{aligned}$$

which implies a required concentration of particles per ml. of:

$$\begin{aligned} \text{Concentration} &= \frac{1}{3.83 \times 10^{-5}} \\ &= 2.6 \times 10^4 / \text{ml.} \end{aligned}$$

Areas used in actual counts were:

- (1) The grid opening as above where small numbers of organisms per opening were encountered;
- (2) The viewing screen of the E.M. 300 (16 cm. diameter) where numbers were higher, so as to produce several viruses on the screen (these levels made counting of a whole square subject to error due to losing track of the individual particles), or
- (3) The area covered by a $3\frac{1}{4}$ x 4 inch photographic plate where significant numbers of particles could be recorded on such a plate.

Note that methods (2) and (3) are dependent on instrumental magnification for calculation whereas (1) is not.

APPENDIX IICalculation of Polystyrene Latex Sphere Concentration

Diameter of spheres: 0.126 micron)
 Density of spheres: 1.05) supplied by manufacturer.

Concentration of spheres: 10.6 percent ($\frac{W}{V}$)

Adjusted concentration: 10.0 percent (0.10 grams/cm³)

Volume of PSL = 0.1/1.05
 = 0.0953 cm³

Volume of one sphere = $\frac{4}{3} r^3$
 = $\frac{4}{3} (6.3 \times 10^{-6})^3$
 = 1.05×10^{-15} cm³

Concentration of PSL = $\frac{9.53 \times 10^{-2}}{1.05 \times 10^{-15}}$
 = 9.1×10^{13} particles per cm³

A further dilution to 9.1×10^{10} particles per
 cm³ was made before use.

APPENDIX IIICalculation of sedimentation times

The time required for complete sedimentation of particles (T_s) was calculated from the formula:

$$T_s = \frac{60}{4\pi^2} \times \frac{1}{Pi} \times \frac{18\eta\bar{v}}{(1-\bar{v}\rho)d^2}$$

where Pi = Performance index of the rotor, given by

$$\frac{\text{rpm}^2}{\log_e R_{\max} - \log_e R_{\min}}$$

η = viscosity (poises) of solvent

\bar{v} = partial specific volume ($\text{cm}^3/\text{gm.}$) of the virus

ρ = density (gm./cm^3) of the solvent

d = diameter of the particle

For example, one may calculate T_s for influenza virus in water at 20°C , assuming a minimum particle diameter of 80 nm. and a partial specific volume of 0.75 (\bar{v} is reported to vary from 0.65 to 0.75 for most viruses (J.M. Kaper in:Molecular Basis of Virology. Reinhold,1968)) and we have taken the factor which would produce the longest time. Determination of real values is impractical as the procedure is complex):

$$T_s = \frac{60}{4 \times 9.87} \times \frac{1}{5.84 \times 10^8} \times \frac{18 \times 0.01 \times 0.75}{(1-0.75) \times (8 \times 10^{-6})^2}$$

= 22 minutes

From this calculation, one could derive sedimentation times for the other viruses by consideration of the ratio of the

square of their diameter to 80 nm^2 , for example a picornavirus of diameter 25 nm. would have a T_s given by:

$$T_s = 22 \times \frac{80^2}{25^2}$$

$$= 102 \text{ min}$$

Vaccinia, being non-spherical requires a further correction factor of $1.1 \times T_s$.

REFERENCES

- Agrawal, H.O. (1966) Studies on the structure of poliovirus. Arch. Ges. Virusforsch. 19:365-372.
- Akers, T.G. (1969) in:An Introduction to Experimental Aerobiology. (R.L. Dimmick and A.B. Akers, eds.) Wiley - Interscience, N.Y. p. 297.
- Alford, R.H., J.A. Kasel, P.J. Gerone and V. Knight (1966) Human influenza resulting from aerosol inhalation. Soc. Exp. Biol. Med. 122: 800-804.
- Almeida, J.D. and A.P. Waterson (1967) Some observations on the envelope of an influenza virus. J. gen. Microbiol. 46: 107-110.
- Anderer, F.A., H.D. Schlumberger, M.A. Koch, H. Frank and H.J. Eggers (1967) Structure of simian virus 40. II. Symmetry and components of the virus particle. Virology 32: 511-523.
- Apostolov, K., and T.H. Flewett (1969) Further observations on the structure of influenza viruses A and C. J. gen. Virol. 4:365-370.
- Archetti, I., A. Jemolo and D. Steve-Bocciarelli (1967) On the fine structure of influenza viruses. Arch. Ges. Virusforsch. 20:133-136.
- Artenstein, M.S. and F.C. Cadigan (1964) Air sampling in viral respiratory disease. Arch. Envir. Hlth. 9:58-60.
- Artenstein, M.S. & W.S. Miller (1966) Air Sampling for Respiratory Disease Agents in Army Recruits. Bact. Rev. 30:571-572.
- Artenstein, M.S., W.S. Miller, J.H. Rust, jr., & T.H. Lamson (1967) Large volume air sampling of human respiratory disease pathogens. Amer. J. Epid. 85: 479-485.
- Bayer, M.E. & C.C. Remsen (1970) Bacteriophage T2 as seen with the freeze-etching technique. Virology 40:703-718.
- Bradley, D.E. (1967) Ultrastructure of bacteriophages & bacteriocins. Bact. Rev. 31:230-314.

- Breedis, C., L. Berwick and T.F. Anderson (1962) Fractionation of Shope papilloma virus in cesium chloride density gradient. *Virology*, 17: 84-94.
- Breese, S.S., Jr., and R. Trautman (1960) Examination of spray-droplet particle counting as a measure of virus concentration. *Virology* 10:57-72.
- Breese, S.S. jr., R. Trautman and H.L. Bachrach (1965) Rotational symmetry in foot-and-mouth disease virus and models. *Science* 150: 1303-1305.
- Brenner, S. and R.W. Horne (1959) A negative staining method for high resolution electron microscopy of viruses. *Biochim. Biophys. Acta* 34: 103-110.
- Brit. Med. J. (1970) Airborne transmission of smallpox. *Editorial.v.4*, p.127.
- Chatigny, M.A. (1961) Protection against infection in the microbiological laboratory: devices and procedures. *Adv. Appl. Microbiol.* 3: 131-192.
- Chaudhary, R.K., D.A. Kennedy and J.C.N. Westwood (1971) Serological cross-reactivity within the picornaviruses as studied by electron microscopy. *Can.J. Microbiol.* 17: 477-480.
- Chescoe, D. and A.W. Agar (1966) Interpretation des micrographies en tres haute resolution. *J. Microscopie* 5:91-94.
- Cooper, P.D. (1961) A chemical basis for the classification of animal viruses. *Nature* 190:302-305.
- Couch, R.B., T.R. Cate, R.E. Douglas, jr., P.J. Gerone and V. Knight (1966) Effect of route of inoculation on experimental respiratory viral disease in volunteers and evidence for airborne transmission. *Bact.Rev.* 30:517-529.
- Couch, R.B., R.G. Douglas, jr., K.M. Lindgren, P.J. Gerone and V. Knight (1970) Airborne transmission of respiratory infection with coxsackievirus A type 21. *Amer.J. Epid.* 91:78-86.
- Davis, B.D., R. Dulbecco, H.N. Eisen, H.S. Ginsberg and W.B. Wood, jr. (1968) *Microbiology* (4th ed.) Harper and Row, N.Y.

- Dimmick, R.L. (1969) in: An Introduction to Experimental Aerobiology. (R.L. Dimmick and A.B. Akers, eds.) Wiley-Interscience, N.Y. pp22-43.
- Doane, F.W., N. Anderson, K. Chatiyanda, R.M. Bannatyne, D.M. McLean and A.J. Rhodes (1967) Rapid laboratory diagnosis of paramyxovirus infections by electron microscopy. Lancet ii: 751-753.
- Doane, F.W., N. Anderson and A.J. Rhodes (1969) Application of electron microscopy to the diagnosis of virus infections. Can. Med. Assoc. J. 100: 1043-1049.
- Dowling, H.F. (1966) Airborne infections - the past and the future. Bact. Rev. 30: 485-487.
- Downie, A.W., M. Mieklejohn, L. St. Vincent, A.R. Rao, B.V. Sundara Babu and C.H. Kempe (1965) The recovery of smallpox virus from patients and their environment in a smallpox hospital. Bull. W.H.O. 33: 615-622.
- Dunker, A.K. and R.R. Rueckert (1971) Fragments generated by pH dissociation of ME-virus and their relation to the structure of the virion. J. Mol. Biol. 58: 217-235.
- Easterbrook, K.B. (1966) Controlled degradation of vaccinia virions "in vitro": an electron microscopic study. J. Ultrastruct. Res. 14: 484-496.
- Evans, A.S. and L.J. Melnick (1949) Electron microscope studies of the vesicle and spinal fluids from a case of herpes zoster. Soc. Exp. Biol. Med. 71: 283-286.
- Finch, J.T., and A. Klug (1959) Structure of poliomyelitis virus. Nature 183: 1709-1714.
- Finch, J.T. and A. Klug (1965) The structure of viruses of the papilloma-polyoma type. III Structure of rabbit papilloma virus with appendix on the topography of contrast in negative staining for electron microscopy. J. Mol. Biol. 13: 1-12.
- Flewett, T.H. and K. Apostolov (1967) A reticular structure in the wall of influenza C virus. J. Gen. Virol 1: 297-304.
- Galasso, G.J. and D.G. Sharp (1963) Homologous inhibition, toxicity and multiplicity reactivation with ultraviolet irradiated vaccinia virus. J. Bacteriol. 85: 1309-1314.

- Gelderblom, H., H. Bauer, H. Frank and R. Wigand (1967)
The structure of group eleven adenoviruses.
*J.gen. Virol.*1:553-560.
- Gerone, P.J., R.B. Couch, G.V. Keefer, R.G. Douglas, E.B.
Derrenbacher and V. Knight (1966) Assessment of
experimental and natural virus aerosols.
*Bact.Rev.*30:576-584.
- Gordon, J.E. and T.H. Ingalls (1957) Contact and airborne
transmission of infectious agents. *Am. J.Med.Sci.*
233:334-357.
- Hammerling, U., T. Aoki, H.A. Wood, L.J. Old, E.A. Boyse
& E.deHarven (1969) New visual markers of antibody for
electron microscopy. *Nature* 233:1158-1159.
- Hare, R. (1964) The transmission of respiratory infections.
*Proc.Roy. Soc.Med.*57:221-230.
- Haydon, G.B. (1969a) An electron-optical lens effect as a
possible source of contrast in biological preparations.
*J. Microsc.*90:1-13.
- Haydon, G.B. (1969b) On the interpretation of high resolution
electron micrographs of macromolecules. *J. Ultrastruct.*
*Res.*25:349-361.
- Horne, R.W. and J. Nagington (1959) Electron microscope studies
of the development and structure of poliomyelitis
virus. *J. Mol.Biol.*1:333-338.
- Horne, R.W., S. Brenner, A.P. Waterson and P.Wildy (1959)
The icosahedral form of an adenovirus. *J. Mol. Biol.*1:
84-86.
- Horne, R.W., A.P. Waterson, P. Wildy and A.E. Farnham (1960)
The structure and composition of the myxoviruses.
1. Electron microscope studies of the structure of
myxovirus particles by negative staining techniques.
Virology 11:79-98.
- Hoyle, L., R.W. Horne and A.P. Waterson (1961) The structure
and composition of the myxoviruses. II Components
released from the influenza virus particle by ether.
Virology 13:448-459.

- Hoyle, I., R.W.Horne and A.P. Waterson (1962) The structure and composition of the myxoviruses. III The interaction of influenza virus particles with cytoplasmic particles derived from normal chorioallantoic membrane cells. *Virology* 17:533-542.
- Isaacs, A. (1957) Particle counts and infectivity titrations for animal viruses. *Adv.Virus Res.* 4:111-158.
- Jamison, R.M. (1969) Morphology of echovirus 22. *J.Virol.* 4:904-906.
- Jamison, R.M. and H.D. Mayor (1966) Comparative study of seven picornaviruses of man. *J. Bact.* 91:1971-1976.
- Johnson, D.J. (1968) Amplitude and phase contrast in electron-microscope images of molecular structures. *J.Roy.Micr. Soc.* 88:39-47.
- Joncas, J. H., R. Williams, L. Berthiaume and P. Beaudry (1969) Diagnosis of viral respiratory infections by electron microscopy. *Lancet* 1:956-959.
- Kaplan, C. and R.C. Valentine (1959) The infectivity of purified and partially purified preparations of vaccinia and cowpox viruses. *J.Gen. Microbiol.* 20:612-619.
- Kellenberger, E. and W. Arber (1957) Electron microscopical studies of phage multiplication. I. A. method for quantitative analysis of particle suspensions. *Virology* 3: 245-255.
- Kerridge, D., R.W. Horne and A.M. Glauert (1962) Structural components of flagella from Salmonella typhimurium. *J. Mol. Biol.* 4:227-238.
- Langmuir, A.D. (1961) Epidemiology of airborne infection. *Bact.Rev.* 25:173-181.
- Langmuir, A.D. (1964) Airborne infection: how important for public health? I. A historical review. *Am.J. Pub. Health* 54:1666-1668.
- Lwoff, A., R.W. Horne and P.Tournier (1962) A system of viruses. *Sympos.Quant. Biol.* 27:51-55.
- Markham, R., S. Frey and G.J. Hills (1963) Methods for the enhancement of image detail and accentuation of structure in electron microscopy. *Virology* 20:88-102.

- Mayor, H.D. (1964) Picornavirus symmetry. *Virology* 22:156-160.
- Med.J. Aust. (1970) Smallpox in Europe and its aerial spread. *Comment.* 4:861-862.
- Medzon, E.L. and H. Bauer (1970) Structural features of vaccinia virus revealed by negative staining, sectioning and freeze-etching. *Virology* 40:860-867.
- Melnick, J.L., W.C. Cockburn, G. Dalldorf, S. Gard, J.H.S. Gear, W.M. Hammon, M.M. Kaplan, F.P. Nagler, N.Oker-Blom, A.H. Rhodes, A.B. Sabin, J.D. Verlinde and H. von Magnus (1963) Picornavirus group. *Virology* 19:114-116.
- Mitchiner, M.B. (1969) The envelope of vaccinia and orf viruses: an electron-cytochemical investigation. *J.gen.Virol.* 5: 211-220.
- Monroe, J.H. and P.M. Brandt (1970) Rapid semiquantitative method for screening large numbers of virus samples by negative staining electron microscopy. *Appl. Microbiol.* 20:259-262.
- Morton, J.D. (1963) in: A symposium on Aerobiology, 1963. (R.L. Dimmick, ed.) Naval Supply Centre, Oakland, Calif. pp.183-186.
- Muller, G., and G. Neilsen (1970) Elektronenmikroskopische Partikelzahlung in der Virologie. II Ursachen systematischer Fehler bei Sedimentationsverfahren. *Arch.Ges.Virusforsch.* 20:22-30.
- Murphy, F.A. & M.T. Coleman (1969) Internal and surface structure of Hong Kong influenza virus. *Bull.W.H.O.* 41:703-704.
- Nagington, J., A.A. Newton and R.W. Horne (1964) The structure of orf virus. *Virology* 23:461-472.
- Nagler, F.P.O. and G. Rake (1948) The use of the electron microscope in diagnosis of variola, vaccinia and varicella. *J. Bact.* 55:45-51.
- Nermut, M.V. and H. Frank (1971) Fine structure of influenza A2 (Singapore) as revealed by negative staining, freeze-drying and freeze-etching. *J.gen.Viral.* 10:37-51.

- Norrby, E. (1969) The structural and functional diversity of adenovirus capsid components. *J. gen. Virol.* 5:221-236.
- Parsons, D.F. (1963) Negative staining of thinly spread cells and associated virus. *J. Cell Biol.* 16:620-626.
- Parsons, D.F. (1970) in: Some Biological Techniques in Electron Microscopy. Academic Press, N.Y. pp.1-68.
- Pease, D.C. (1964) Histological Techniques for Electron Microscopy. 2nd ed. Academic Press, N.Y. p.192-215.
- Pinteric, L. and J. Taylor (1962) The lowered drop method for the preparation of specimens of partially purified virus lysates for quantitative electron micrographic analysis. *Virology* 18:359-371.
- Rhim, J.S., K.O. Smith and J.L. Melnick (1961) Complete and coreless forms of reovirus (echo 10). Ratio of number of virus particles to infective units in the one step growth cycle. *Virology* 15: 428-435.
- Riley, R.L. and F. O'Grady (1961) Airborne Infection. The Macmillan Co., N.Y.
- Roizman, B. (1969) Herpesviruses. in: The Biochemistry of Viruses. (H.B. Levy, ed.) Marcel Dekker, N.Y. p.415-482.
- Roizman, B., S.B. Spring and J. Schwartz (1969) The herpesvirion and its precursors made in productively and in abortively infected cells. *Federation Proc.* 28:1890-1898.
- Sharp, D.G. (1949) Enumeration of virus particles by electron microscopy. *Soc. Exp. Biol. Med.* 70:54-59.
- Sharp, D.G. (1960) Sedimentation counting of particles via electron microscopy in: 4th International Congress on Electron Microscopy. Springer, Berlin.
- Sharp, D.G. (1963) Total multiplicity in the animal virus - cell reaction and its determination by electron microscopy. *Ergeb. Microbiol.* 36:215-260.
- Sharp, D.G. (1965) Quantitative use of the electron microscope in virus research. Methods and recent results of particle counting. *Lab. Invest.* 14:831-863.

- Sharp, D.G., E.A. Eckert, D. Beard and J.W. Beard (1952) Morphology of the virus of avian erythromyeloblastic leucosis and a comparison with the agent of Newcastle disease. *J. Bact.* 63:151-161.
- Sjostrand, F.S. (1967) *Electron Microscopy of Cells and Tissues. v.1 Instrumentation and Techniques.* Academic Press, London.
- Smith, K.O. and J.L. Melnick (1962) A method for staining virus particles and identifying their nucleic acid type in the electron microscope. *Virology* 17:480-490.
- Strauss, M.J., E.W. Shaw, H. Bunting and J.L. Melnick (1949) "cystalline" virus - like particles from skin papillomas characterized by intranuclear inclusion bodies. *Soc. Exp. Biol. Med.* 72: 46-50.
- Sulkin, S.E. (1961) Laboratory acquired infections. *Bact. Rev.* 25:203-209.
- Sulkin, S.E. and R.M. Pike (1969) *in: Diagnostic Procedures for Viral and Rickettsial Infections. 4th ed.* (E.H. Lennette and N.J. Schmidt, eds.) A.P.H.A., N.Y. pg. 66-78.
- Svehag, S.E. and B. Bloth (1967) Examination of virus M antibody complexes by electron microscopy. I. Configuration of M antibodies and mode of attachment to antigen. *Virology* 31:676-687.
- Tyrrell, D.A.J. (1965) *Common Colds and Related Diseases.* Edward Arnold, London.
- Tyrrell, D.A.J. and J.D. Almeida (1968) Direct electron microscopy of organ cultures for the detection and characterization of viruses. *Arch. Ges. Virusforsch.* 22: 417-425.
- Valentine, R.C. and H.G. Pereira (1965) Antigens and structure of the adenovirus. *J. Mol. Biol.* 13:13-20
- Van Rooyen, C.E. and G.D. Scott (1948) Smallpox diagnosis with special reference to electron microscopy. *Can. J. Public Health* 39:467-477.

- Waterson, A.P. (1964) in: Techniques in Experimental Virology. (R.J.C. Harris, ed.) Academic Press, London, p.367.
- Waterson, A.P., J.M.W. Hurrell and K.E. Jensen (1963) The fine structure of influenza A,B and C viruses. Arch.Ges.Virusforsch. 12: 487-495.
- Watson, D.H. (1962) Electron-micrographic particle counts using phosphotungstate-sprayed virus. Biochim. Biophys. Acta 61:321-331.
- Watson, D.H. (1968) in: The Molecular Biology of Viruses. Camb. Univ. Press, London. p.207-228.
- Wedum, A.G.(1964) Airborne infections in the laboratory. Am.J. Publ.Health 54:1669-1673.
- Wehrle, P.F., J. Posch, K.H. Richter and D.A. Henderson (1970) An airborne outbreak of smallpox in a German hospital and its significance with respect to other recent outbreaks in Europe. Bull.W.H.O. 43: 669-679.
- Wells, W.F. (1934) Airborne infection. II Droplets and droplet nuclei. Am. J. Hyg. 20:611-618.
- Wells, W.F. (1955) Airborne Contagion and Air Hygiene. Harvard University Press, Cambridge, Massachusetts.
- Westwood, J.C.N., W.J. Harris, H.T. Zwartouw, D.H.J. Titmuss and G. Appleyard (1964) Studies on the structure of vaccinia virus. J.gen. Microbiol. 34:67-78.
- Wilcox, W.C., H.S. Ginsberg and T.F. Anderson (1963) Structure of type 5 adenovirus. II Fine structure of virus subunits. Morphological relationship of structural subunits to virus-specific soluble antigens from infected cells. J.Exptl.Med. 118:307-313
- Wildy, P., W.C. Russell and R.W. Horne (1960) The morphology of herpes virus. Virology 12:204-222.
- Williams, R.E.O. (1960) Intramural spread of bacteria and viruses in human populations. Ann.Rev. Microbiol. 14:43-64.
- Williams, R.C. and R.C. Backus (1949) Macromolecular weights determined by direct particle counting. 1. The weight of the bushy stunt virus particle. J.Am.Chem.Soc. 71:4052-4057.