



National Library  
of Canada

Bibliothèque nationale  
du Canada

Canadian Theses Service    Service des thèses canadiennes

Ottawa, Canada  
K1A 0N4

## NOTICE

The quality of this microform is heavily dependent upon the quality of the original thesis submitted for microfilming. Every effort has been made to ensure the highest quality of reproduction possible.

If pages are missing, contact the university which granted the degree.

Some pages may have indistinct print especially if the original pages were typed with a poor typewriter ribbon or if the university sent us an inferior photocopy.

Reproduction in full or in part of this microform is governed by the Canadian Copyright Act, R.S.C. 1970, c. C-30, and subsequent amendments.

## AVIS

La qualité de cette microforme dépend grandement de la qualité de la thèse soumise au microfilmage. Nous avons tout fait pour assurer une qualité supérieure de reproduction.

S'il manque des pages, veuillez communiquer avec l'université qui a conféré le grade.

La qualité d'impression de certaines pages peut laisser à désirer, surtout si les pages originales ont été dactylographiées à l'aide d'un ruban usé ou si l'université nous a fait parvenir une photocopie de qualité inférieure.

La reproduction, même partielle, de cette microforme est soumise à la Loi canadienne sur le droit d'auteur, SRC 1970, c. C-30, et ses amendements subséquents.



National Library  
of Canada

Bibliothèque nationale  
du Canada

Canadian Theses Service    Service des thèses canadiennes

Ottawa, Canada  
K1A 0N4

The author has granted an irrevocable non-exclusive licence allowing the National Library of Canada to reproduce, loan, distribute or sell copies of his/her thesis by any means and in any form or format, making this thesis available to interested persons.

The author retains ownership of the copyright in his/her thesis. Neither the thesis nor substantial extracts from it may be printed or otherwise reproduced without his/her permission.

L'auteur a accordé une licence irrévocable et non exclusive permettant à la Bibliothèque nationale du Canada de reproduire, prêter, distribuer ou vendre des copies de sa thèse de quelque manière et sous quelque forme que ce soit pour mettre des exemplaires de cette thèse à la disposition des personnes intéressées.

L'auteur conserve la propriété du droit d'auteur qui protège sa thèse. Ni la thèse ni des extraits substantiels de celle-ci ne doivent être imprimés ou autrement reproduits sans son autorisation.

ISBN 0-315-68027-X

Canada



UNIVERSITÉ D'OTTAWA  
UNIVERSITY OF OTTAWA

For my parents and Catherine

## Abstract

### Part A

#### Chapter 1

The Sharpless epoxidation product from E-4-phenyl-2-butene-1-ol and diethyl D-tartrate was converted into L-(-)-phenylalanine in three steps. After completion of the above synthesis Sharpless published an extensive study of the synthesis of  $\alpha$ -amino acids via essentially the same route. Therefore the project was abandoned.

Optically active 2-arylpropionic acids such as 2-phenylpropionic acid, 2-naphthylpropionic acid, and 2-(4-isobutylphenyl)-propionic acid (Ibuprofen) were synthesized in two steps from Sharpless epoxidation products.

### Part B

#### Chapter 2

The synthesis of 4-carboethoxy-4,6-dihydro-thieno[3,4-b]thiophene 5,5-dioxide and 4-phenyl analogue, precursors to thiophene xylylenes, are reported. Attempts to trap the carboethoxy substituted xylylene with electron rich or electron poor dienophiles failed and only dimers were produced. In contrast, the phenyl substituted xylylene gave moderate yields of Diels-Alder adducts in

trapping experiments with dienophiles such as dimethylacetylene dicarboxylate, dimethyl fumarate, and benzoquinone.

### Chapter 3

Several additional examples of a conceptually new route to 1,3-dihydrobenzothiophene-2,2-dioxides from  $\alpha$ -diazo- $\beta$ -sulfonyl esters via a formal rhodium carbenoid insertion into an aromatic C-H bond is reported. Our attempts to extend the scope of this reaction to include insertion into furan derivatives failed. We obtained very unusual furan ring opened products. When the same rhodium carbenoid reactions were carried out with  $\alpha$ -diazo- $\beta$ -ketoamides, 2-hydroxy-3-acetylindole derivatives were formed.

### Chapter 4

In order to gain insight into the rhodium carbenoid reaction mechanism, the diazo precursors to 1,3-dihydrobenzothiophene-2,2-dioxide, 2-indanone, and 2-tetralone which were mono substituted at the ortho position of the aromatic ring were synthesized and the hydrogen/deuterium isotope effects were measured. The observed isotope effects ranged from 3.3-4.9. Furthermore, deuterium NMR indicated that scrambling had occurred during the cyclization step. These data have been interpreted to show that these rhodium carbenoid reactions should be considered as electrophilic aromatic substitution reactions.

## ACKNOWLEDGEMENTS

I would like to take this opportunity to thank the following people who contributed to the completion of this thesis.

Most importantly, my supervisor, Professor Tony Durst, whose guidance, advice, and encouragement is greatly appreciated. I learned more chemistry during the discussions in the back room over a cup of coffee than in any of the courses I took. I appreciated that he was always available to "talk chemistry".

I would also like to thank Raj Capoor for his NMR services, especially in chiral shift reagent studies, and Dr. Heather Dettman for running valuable deuterium NMR. Thanks also to Dr. Clem Kazakoff for his superb mass spectral services.

I would like to thank Livain Breau for his support and countless favours in the lab over the past four years.

Thanks to my parents who shaped my life. Their emotional support over the last 30 years is warmly felt.

Finally, I would like to express my appreciation to my wife Catherine who helped me for the last two summers in the lab, for all the emotional support she provided at home, and for organizing and typing this thesis.

**TABLE of CONTENTS**

Abstract.....	iii
Acknowledgements .....	v
Table of contents .....	vi
List of Spectra.....	viii
List of abbreviations.....	x
<b>CHAPTER 1</b>	
Introduction.....	1
Discussion and Results.....	2
1. $\alpha$ -Amino acids .....	2
2. 2- Aryl propionic acids.....	12
Experimental Section .....	41
References .....	53
<b>CHAPTER 2</b>	
Introduction.....	55
Generation and synthetic utility of o-quinodimethanes .....	56
Results and Discussion.....	63
Trapping Experiments.....	67
Experimental Section .....	90
References .....	99
<b>CHAPTER 3</b>	
Introduction.....	101
Discussion and Results.....	104
Preparation of 2,5-dihydrothiophenes fused to aromatic rings .....	104

Preparation of 3-acetyl-2-hydroxyindoles.....	119
Experimental .....	139
References .....	154
<b>CHAPTER 4</b>	
Introduction.....	156
Intermolecular reactions of rhodium carbenoids with aromatic substrates.....	160
Intramolecular reactions of rhodium carbenoids with aromatic substrates.....	163
Insertion of rhodium carbenoids into aliphatic C-H bonds .....	168
Competition between aliphatic C-H insertion and aromatic substitution reactions.....	170
Results and Discussion.....	174
Experimental Section .....	198
Appendix 1.....	207
Appendix 2.....	210
Appendix 3.....	213
References .....	216
CLAIMS to ORIGINAL RESEARCH.....	218

## List of Spectra

### CHAPTER 1

<sup>1</sup> H NMR spectrum of compound 51a.....	21
<sup>1</sup> H NMR spectrum of compound 51a with chiral shift reagent.....	22
<sup>1</sup> H NMR spectrum of compound 51b.....	23
<sup>1</sup> H NMR spectrum of compound 51b with chiral shift reagent.....	24
<sup>1</sup> H NMR spectrum of compound 51c.....	25
<sup>1</sup> H NMR spectrum of compound 51c with chiral shift reagent.....	26
<sup>1</sup> H NMR spectrum of compound 48a.....	30
<sup>1</sup> H NMR spectrum of compound 48a with chiral shift reagent.....	31
<sup>1</sup> H NMR spectrum of compound 48b.....	32
<sup>1</sup> H NMR spectrum of compound 48b with chiral shift reagent.....	33
<sup>1</sup> H NMR spectrum of compound 48c.....	34
<sup>1</sup> H NMR spectrum of compound 48c with chiral shift reagent.....	35

### CHAPTER 2

<sup>1</sup> H NMR spectrum of compound 32.....	71
<sup>1</sup> H NMR spectrum of compound 53.....	77

$^1\text{H}$ NMR spectrum of compound 61.....	83
$^1\text{H}$ NMR spectrum of compound 65.....	84
<b>CHAPTER 3</b>	
$^1\text{H}$ NMR Spectrum of compound 2c.....	111
$^1\text{H}$ NMR Spectrum of compound 7.....	115
$^1\text{H}$ NMR Spectrum of compound 24a.....	125
$^1\text{H}$ NMR Spectrum of compound 24e.....	126
$^1\text{H}$ NMR Spectrum of compound 29 .....	130
<b>CHAPTER 4</b>	
$^1\text{H}$ NMR Spectrum of compound 73 .....	182
$^2\text{H}$ NMR Spectrum of compound 73 .....	183
$^1\text{H}$ NMR Spectrum of compound 76 .....	186
$^2\text{H}$ NMR Spectrum of compound 76 .....	187
$^1\text{H}$ NMR Spectrum of compound 59 .....	188
$^2\text{H}$ NMR Spectrum of compound 59 .....	189

## LIST of ABBREVIATIONS

Ac.....	acetyl
Ar.....	aryl
aq.....	aqueous
b.p.....	boiling point
°C.....	degrees Celsius
ci.....	chemical ionization
(CH <sub>3</sub> ) <sub>3</sub> Al.....	trimethylaluminium
CH <sub>2</sub> N <sub>2</sub> .....	diazomethane
cm.....	centimeter
d.....	doublet
ei.....	electron impact
eq.....	equivalents
DET.....	diethyl tartrate
DIPT.....	diisopropyl tartrate
DMF.....	N,N-Dimethylformamide
Et.....	ethyl
EtOAc.....	ethyl acetate
Eu(hfc) <sub>3</sub> .....	Tris[3-(heptafluoropropylhydroxymethylene)-(+)-camphorato], europium(III) derivative
g.....	gram
h.....	hours
HOMCOR.....	homonuclear correlation

Hz.....	Hertz
ir.....	infrared
KOH.....	potassium hydroxide
LDA.....	lithium diisopropylamide
$L_n$ .....	"n"-ligands
M.....	molar
Me.....	methyl
mM.....	millimole
mp.....	melting point
$M^+$ .....	parent molecular ion
MCPBA.....	<i>meta</i> -chloroperoxybenzoic acid
mp.....	melting point
MS.....	mass spectrum
$NaIO_4$ .....	sodium periodate
n-BuLi.....	n-Butyllithium
NMR.....	nuclear magnetic resonance
OAc.....	acetate
OMe.....	methoxy
$PCl_3$ .....	phosphorous trichloride
ppm.....	parts per million
$Rh_2(OAc)_4$ .....	rhodium (II) acetate
TBHP.....	tert-butyl hydroperoxide
tBu.....	<i>tert</i> -butyl
<i>tert</i> .....	tertiary
TFA.....	trifluoroacetic acid
THF.....	tetrahydrofuran

TosN<sub>3</sub>.....tosyl azide

## CHAPTER 1

### Synthesis of optically active $\alpha$ -substituted acids

#### Introduction

There are more than 1850 different types of drugs sold on the retail market in North America. Of these, 1327 are synthetic, and 528 contain at least one chiral centre. Only 61 of these chiral drugs are sold as pure enantiomers; the remaining 467 are marketed as racemic mixtures.<sup>1</sup> From a pharmacological point of view this is unfortunate because the desirable biological activity is generally found in only one of the two enantiomers. The other enantiomer may be toxic, nontoxic, or have as yet unknown biological effects. Ideally all drugs having chiral centres should be marketed in enantiomerically pure form.

Chemical & Engineering News forecasts that the sales of enantiomerically pure drugs will increase from \$US 465 million in 1989 to \$US 2.8 billion in the year 2000.<sup>1</sup> The need for efficient syntheses of these drugs or their precursors is obvious. Key synthetic intermediates for the preparation of new drugs, such as peptides, are  $\alpha$ -amino acids and  $\alpha$ -mercapto acids. Access to such compounds is also possible via allylic epoxy alcohols. 2-Arylpropionic acids have

recently been approved as over-the-counter analgesics. These will compete with traditional analgesics such as acetylsalicylic acid and N-acetyl-p-aminobenzoic acid for the control of minor pain. In this chapter an efficient route to these compounds based on intermediates prepared via Sharpless asymmetric epoxidation of allylic alcohols is described.<sup>2</sup>

## Results and Discussion

### 1. $\alpha$ -Amino acids

At the beginning of this decade Sharpless disclosed the first asymmetric epoxidation of a variety of allylic alcohols in the Journal of the American Chemical Society. He used equimolar amounts of substrate, diethyl tartrate and t-butyl hydroperoxide as an oxidizing agent. He was able to obtain either antipode in high enantiomeric excess by employing either (+) or (-) tartrate. For a successful asymmetric Sharpless epoxidation it is imperative that the hydroxymethyl group be attached to the alkene. (Scheme 1)

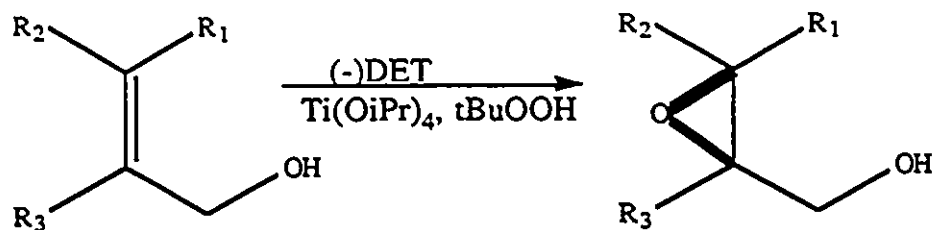
Scheme 1

Recently Sharpless<sup>2</sup> upgraded his epoxidation procedure by using a catalytic amounts of both tartrate and titanium isopropoxide. Under these conditions too the products were obtained with high enantiomeric excess and in very good chemical yields. Thus the readily available epoxy alcohols **1** were considered as ideal starting materials for the preparation of optically active target molecules. Amongst targets we chose were  $\alpha$ -amino acids. Our general approach is represented in Scheme 2. The key aspects of this approach involves stereo and regiospecific ring opening of the epoxy alcohol at C-3 with azide ion followed by oxidative cleavage of the resultant diol and reduction of the azide function. All of these steps have ample literature precedence. Thus the novelty of this approach rests not on the development of new methodology but rather a new combination of known reaction sequences.

Scheme 2

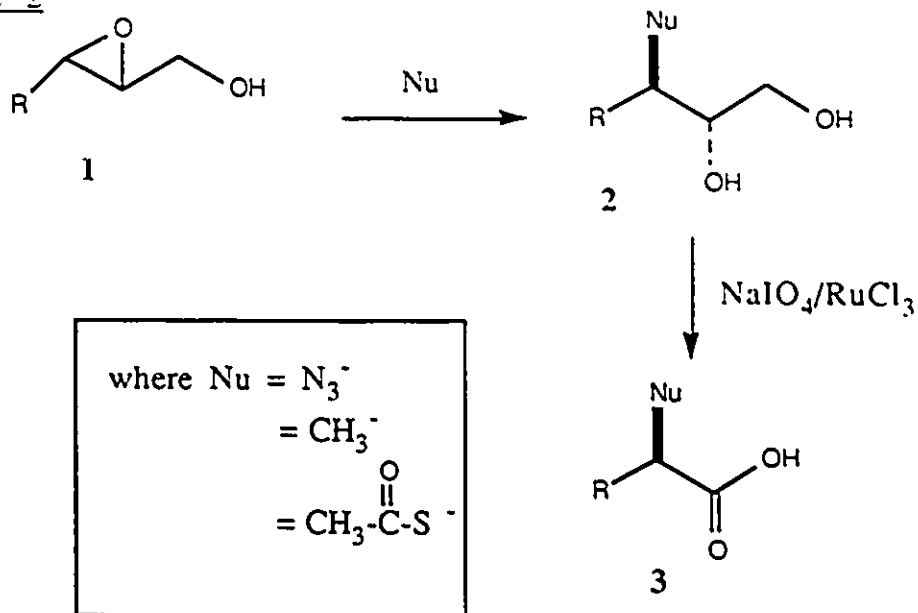

Although many syntheses of optically active  $\alpha$ -amino acids have been reported over the years these compounds continue to hold the attention of synthetic chemists due to the ever increasing use of unnatural or rare amino acids in currently used drugs and in drug design. For example, cyclic peptides incorporating unnatural amino acids are found to show anti tumor properties.<sup>3</sup>  $\alpha$ -Alkylated  $\alpha$ -amino acids are known to be powerful enzyme inhibitors. One of the best known examples is L- $\alpha$ -methyl Dopa 4, an inhibitor of Dopa decarboxylase which is utilized as a therapeutic agent against hypertension.  $\alpha$ -Difluoromethyl Dopa 5 has been suggested as a potential agent against Parkinson's disease.<sup>4,5</sup>

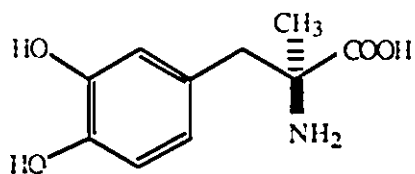

L- $\alpha$ -methyldopa  
4

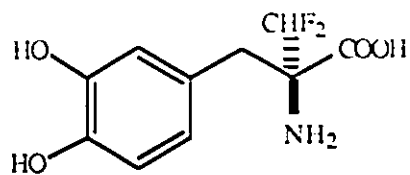

L- $\alpha$ -Difluoromethyldopa  
5

Evans<sup>6</sup>, Oppolzer<sup>7</sup> and Williams<sup>8</sup> are some of the widely known chemists who have published work in this area. They synthesized  $\alpha$ -amino acids using chiral auxiliaries such as the oxazolidine 6, the camphor-10-sulfonamide derivative 7 and the oxazinones 8, respectively

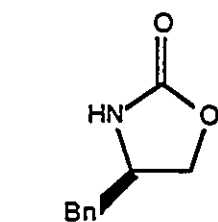

Evan's auxiliary  
1g = \$15  
6

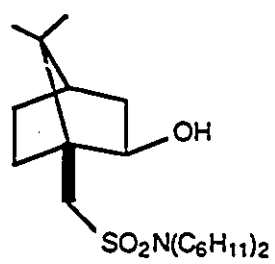

Oppolzer's auxiliary  
1g = \$12  
7

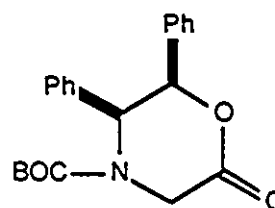

Willam's glycine template  
1g = \$24  
8

The main drawback with the chiral auxiliary approach lies in introducing and removing the chiral auxiliaries before and after chemical transformations in the desired molecule. This is similar to the protection and deprotection steps used in carbohydrate chemistry. In addition, the molecular weight of the chiral auxiliaries

is often high (for example the camphor-10-sulfonamide has M.W. = 398) which makes the synthesis impractical for large scale preparations. Although these chiral auxiliaries are commercially available, they are very expensive. (for example the Oppolzer auxiliary costs \$4800/mole while William's glycine template is \$8136/mole).

The proposed route in Scheme 2 circumvents many of these problems by using Sharpless epoxidation technology. A large number of allylic alcohols are known, the epoxidation can give the key epoxy alcohols with high enantiomeric excess in either optical antipode. The use of epoxy alcohols depends to a considerable extent on the development of regio and stereospecific methods of opening the epoxide ring. This aspect, including the opening of the epoxide ring with azide ion has been studied by Sharpless and others.<sup>9,10,11</sup>

Sharpless examined the epoxide ring opening of 3-propyloxiranemethanol **9** with various nucleophiles including sodium azide and trimethylsilyl azide. Sodium azide opened the epoxide ring preferentially at the C<sub>3</sub> position producing also small amount of C<sub>2</sub> ring opened products in a ratio of 5.8:1. No ring opened products were observed with trimethylsilyl azide alone, but in the presence of titanium isopropoxide as an additive, he obtained C<sub>3</sub> and C<sub>2</sub> ring opened products in a ratio of 14:1.

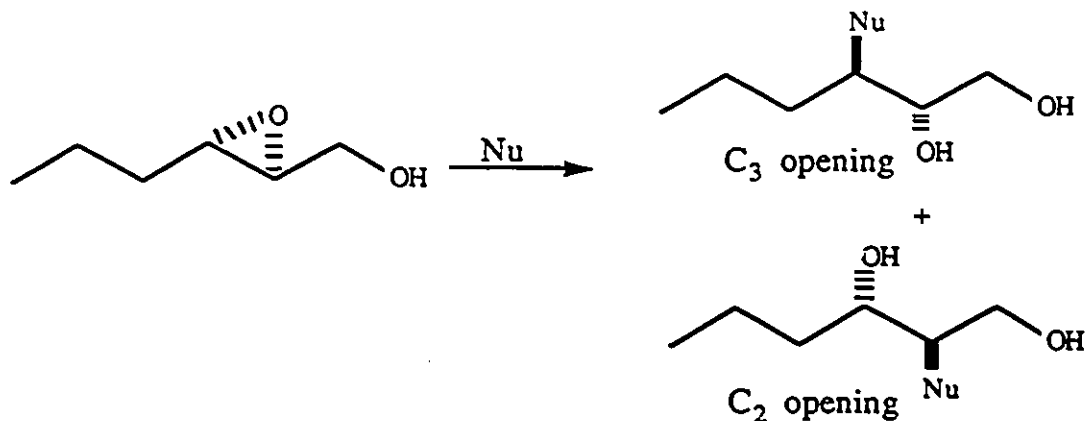

Our initial studies were carried out on crotyl alcohol. This compound was first benzoylated to reduce its water solubility and to obtain a nitrogen protected amino acid as the end product (as a result of an O to N acyl migration). The O-benzoyl ester, 13, was then oxidized to the epoxy benzoate 14 with MCPBA in 52% yield. Ring opening of the epoxide using sodium azide as a nucleophile afforded the desired azido alcohol 15 as the major product in 67% yield, accompanied by 12% of C-2 ring opened product. On hydrogenation of 15 a variety of products namely 16, 17 and 18 were formed. These compounds equilibrated slowly on standing at room temperature. (Scheme 3) Although the desired compound 18 was formed equilibration prevented the isolation of the product. The above sequence of reactions did indicate that the synthesis of protected  $\alpha$ -amino acids is feasible from Sharpless epoxidation products.

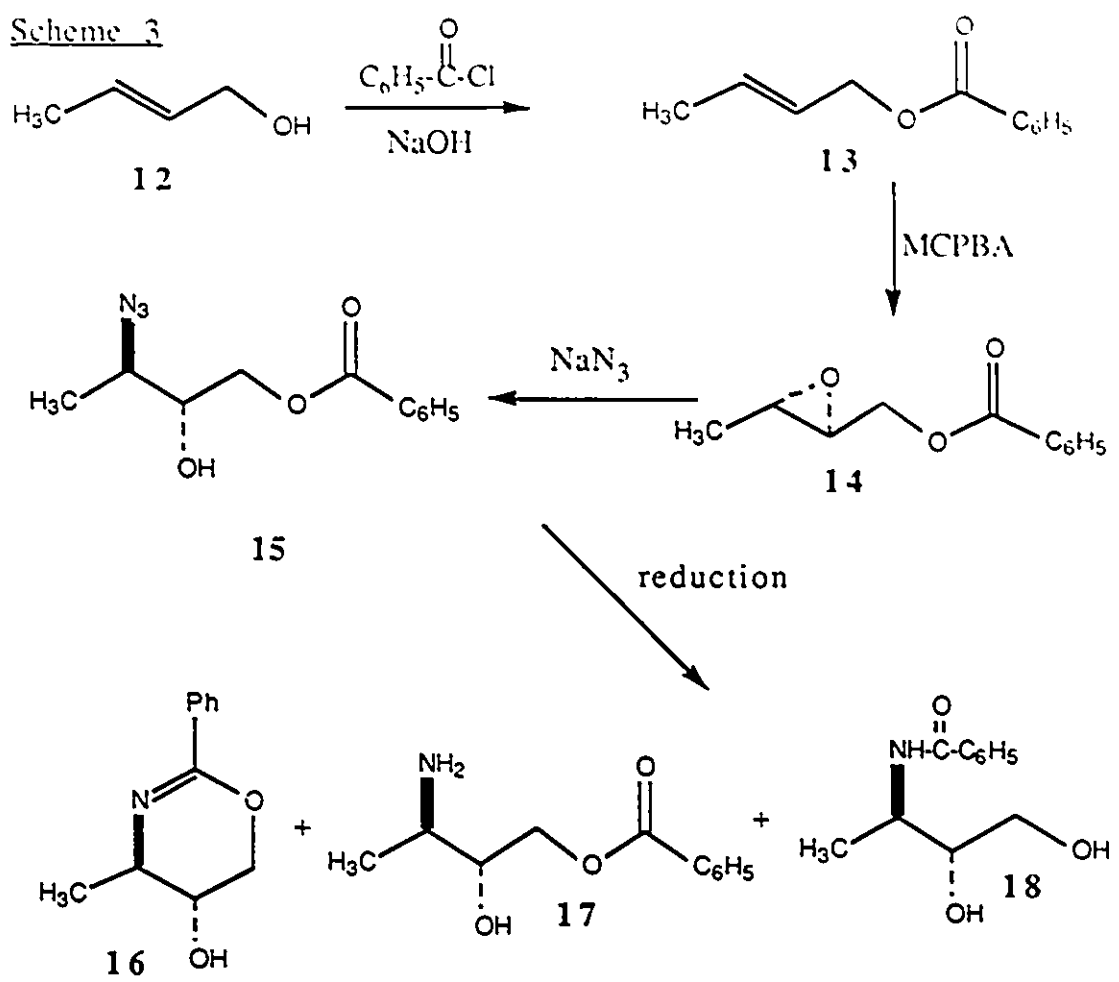

### Synthesis of (d,l) phenylalanine

Phenylacetaldehyde 19 was converted into the  $\alpha,\beta$ -unsaturated alcohol 21 in two simple steps that involved a Wittig reaction and DIBAL reduction in 51% yield. Compound 21 was then epoxidized with MCPBA to give 55% of the epoxy alcohol 22. Treatment with sodium azide resulted in  $C_3$  and  $C_2$  ring opened products in a ratio of 3:1 in a total yield of 56%. Oxidative cleavage of the vicinal diol 23 with sodium periodate afforded the azido

aldehyde (76%), which upon oxidation and subsequent hydrogenolysis of the intermediate azido acid formed racemic phenylalanine in 60% yield. (Scheme 4).

Scheme 4

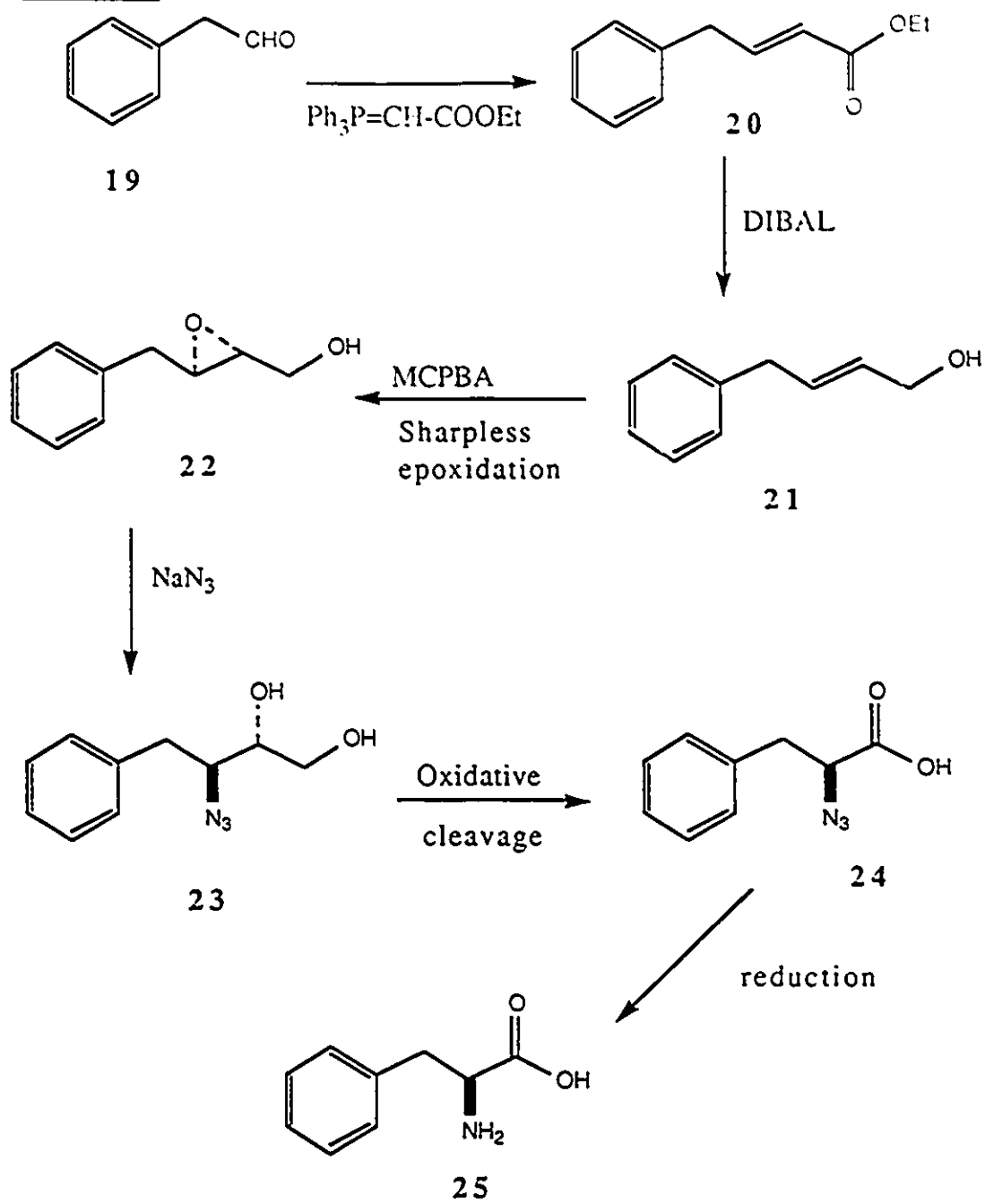

The above sequence was repeated with the exception that the epoxy alcohol 22 was prepared via catalytic asymmetric epoxidation using diethyl D-tartrate. L-Phenylalanine was obtained in similar chemical yields as described above but with only 40% ee. After this initial attempt Sharpless and coworkers published the same approach for the synthesis of optically active  $\alpha$ -amino acids as a communication in the Journal of Organic Chemistry.<sup>12</sup> Therefore no attempts were made to optimize the chemical yields and the enantiomeric excess of the products and further work on this project was stopped.

## 2. 2- Arylpropionic acids

Several hundred million dollars worth of 2-arylpropionic acids are sold yearly on the retail market as non steroidal anti inflammatory drugs. Some of these compounds, including the important Naproxen and Ibuprofen, are represented in Table I. In both Naproxen and Ibuprofen the S (+) enantiomer is pharmacologically active.<sup>13</sup> Before 1986 there were no reported optically active syntheses of 2-arylpropionic acids, but fifteen articles on their synthesis appeared in major journals between 1987 and 1989. Some of the approaches are listed below.

Table I

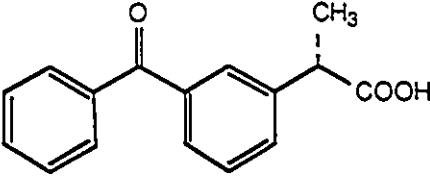
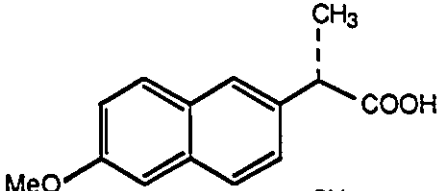
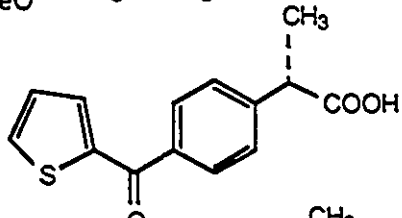
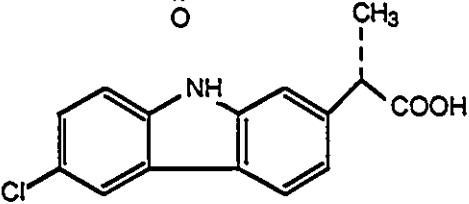
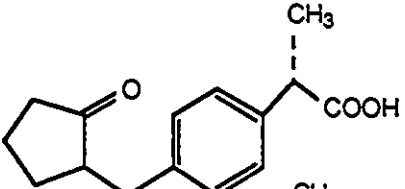
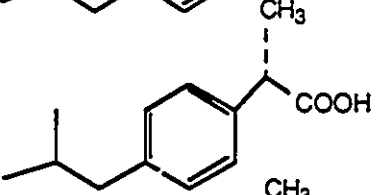
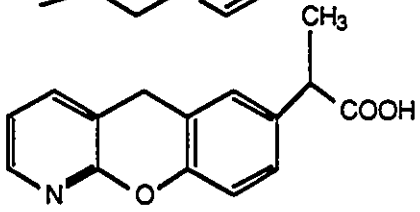
Name	Structural Formula	Manufacturer
Ketoprofen		Specia
Naproxen		Syntex
Suprofen		Janssen
Carprofen		Hoffmann La Roche
Loxoprofen		Sankyo
Ibuprofen		Boots
Pranoprofen		Yoshitomi

Rapoport<sup>14</sup> reported the synthesis of a 2-arylpropionic acid from alanine in an eight step sequence of reactions in very low yield. (eqn 1)

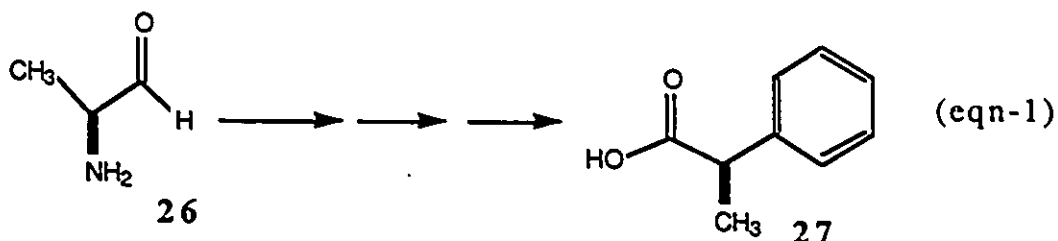

J.K. Stille<sup>15</sup> and his coworkers synthesized these compounds by asymmetric hydroformylation, catalysed by polymer supported platinum complexes on various substituted styrenes. The desired products were obtained in low yields with moderate enantiomeric excess along with some side products. (eqn-2)

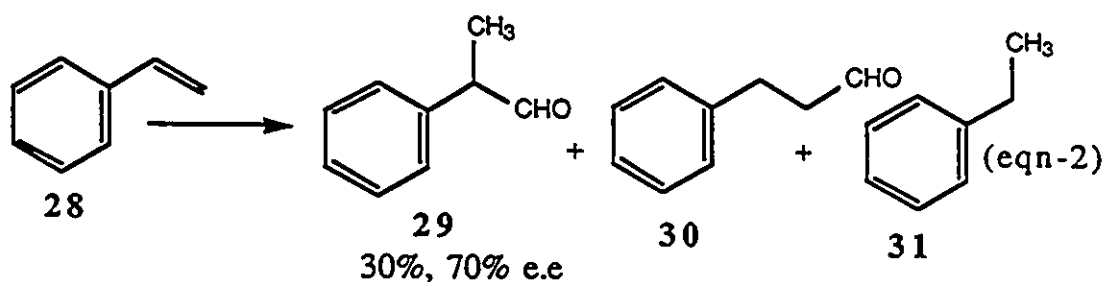

Fuji<sup>16</sup> et al prepared 2-arylpropionic acids via asymmetric alkylation of arylacetic acids. They used binaphthol as a chiral auxiliary and obtained 60-70% chemical yields of various substituted arylacetic acids having approximately 50% ee. (Scheme 5)

Scheme 5

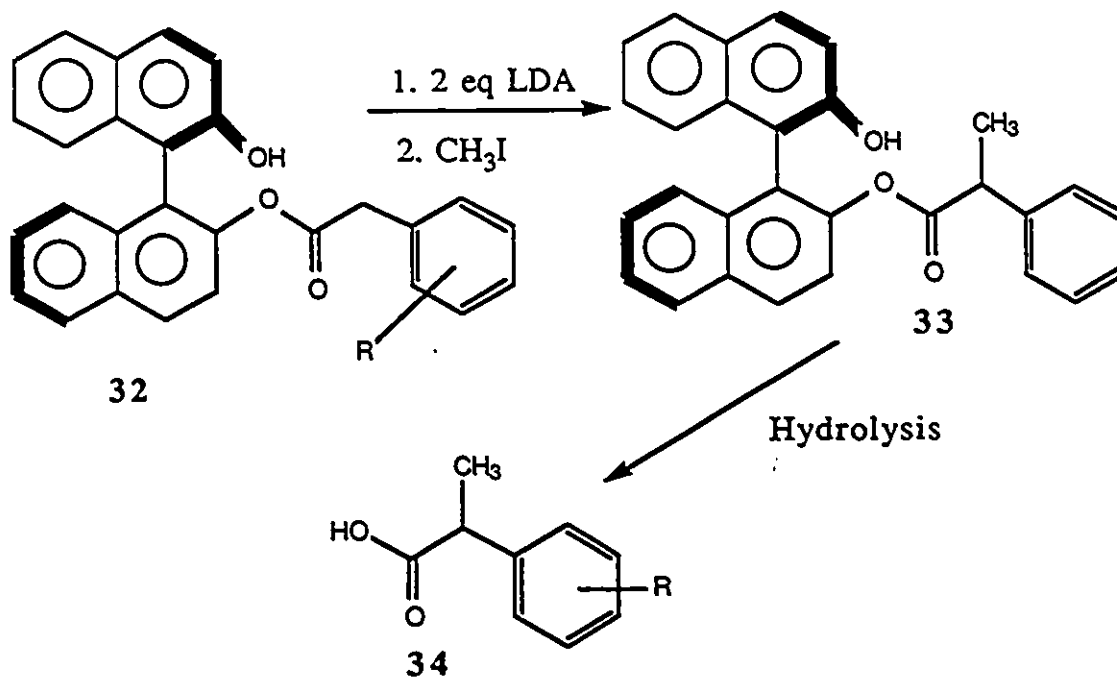

Perhaps the most efficient method of synthesis of this family of compounds involves asymmetric hydrogenation of  $\alpha,\beta$ -unsaturated acids. Noyori<sup>17</sup> used a BINAP-ruthenium (II) complex as a catalyst and obtained Naproxen in 92% yield and in 97% ee from the acrylic acid derivative 37. Reaction conditions are very crucial for successful asymmetric hydrogenation. Different acrylic acid derivatives required careful optimization of reaction conditions.

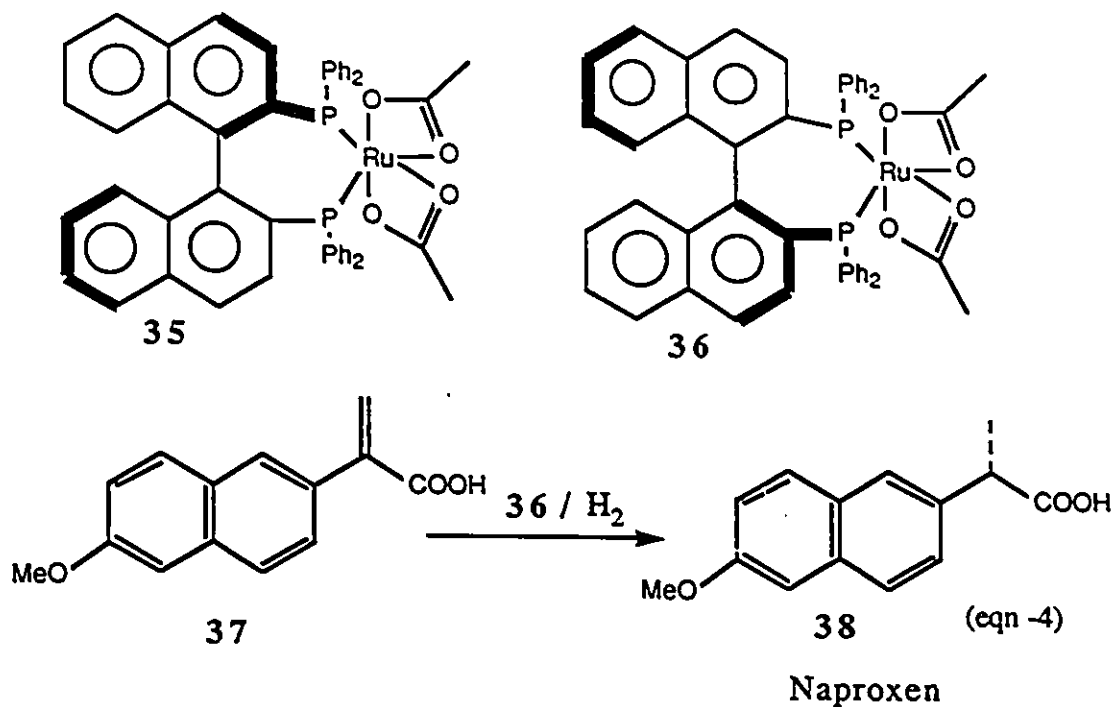

Very recently Larsen<sup>18</sup> et al at Merck synthesized these compounds, by trapping ketenes derived from racemic 2-arylpropionic acids with a variety of chiral alcohols followed by hydrolysis. (Scheme 6) They obtained best results (up to 99% ee) by using pantolactone and methyl lactate as chiral alcohols and rationalized that alcohols in which the carbonyl group is situated at  $\alpha$ -position to OH group are necessary for an effective diastereofacial differentiation. The hydrogen bonding between the two functionalities was suggested to play an important role in the formation of one major diastereoisomer.

Scheme 6

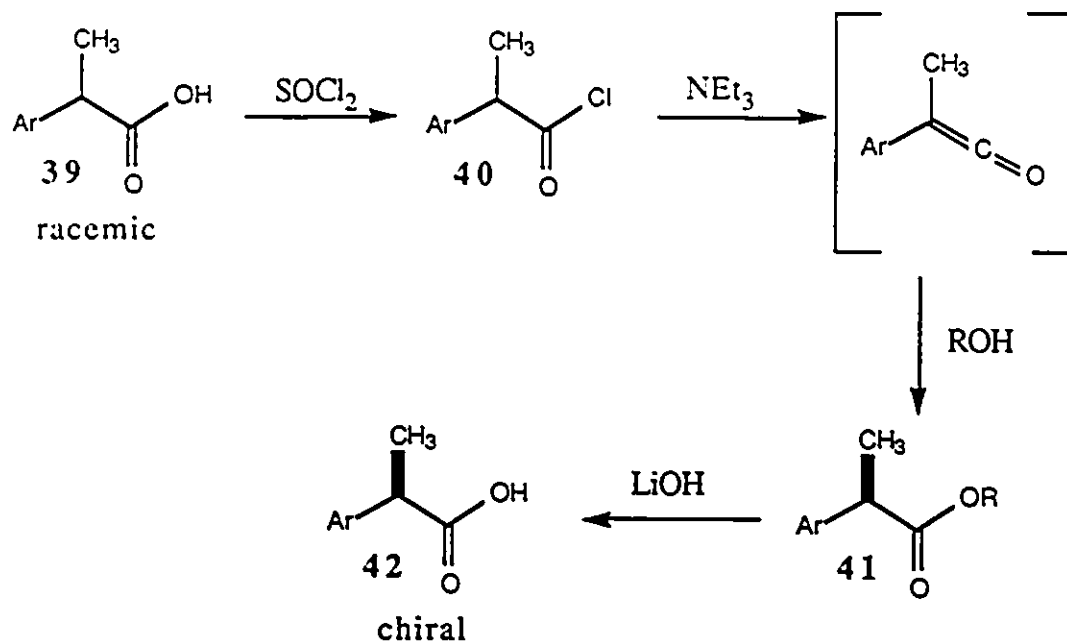

Based on the synthesis of phenylalanine, it was expected that epoxy alcohols on treatment with trimethylaluminium, followed by oxidative cleavage should give 2-arylpropionic acids. If optically pure epoxy alcohols were used, and if the trimethylaluminium reaction occurred regio and stereospecifically then a general approach to these compounds would result. (Scheme 7) The details of yields of the products and enantiomeric excess are compiled in Table II and in Scheme 7.

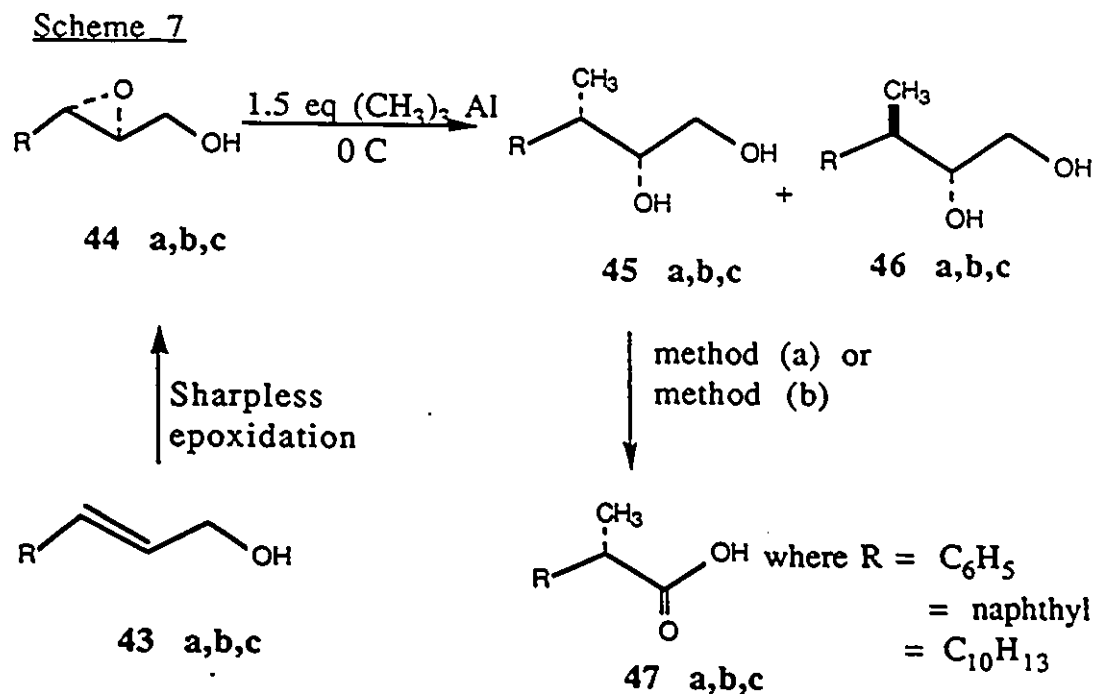

The starting material for the Sharpless epoxidation, 43a, is available from Aldrich. The other starting materials were prepared by simple sequences. The naphthyl derivative, 43b, was synthesized in two steps from 2-naphthaldehyde (eqn-4), while p-isobutylstyrene, prepared from p-isobutylbenzene following Stilles' procedure<sup>15</sup> (eqn-5), was converted to 43c in three chemical transformations.

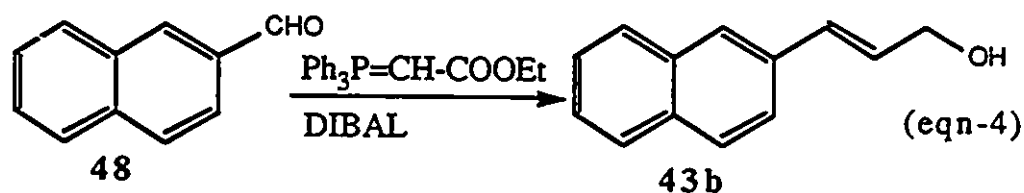

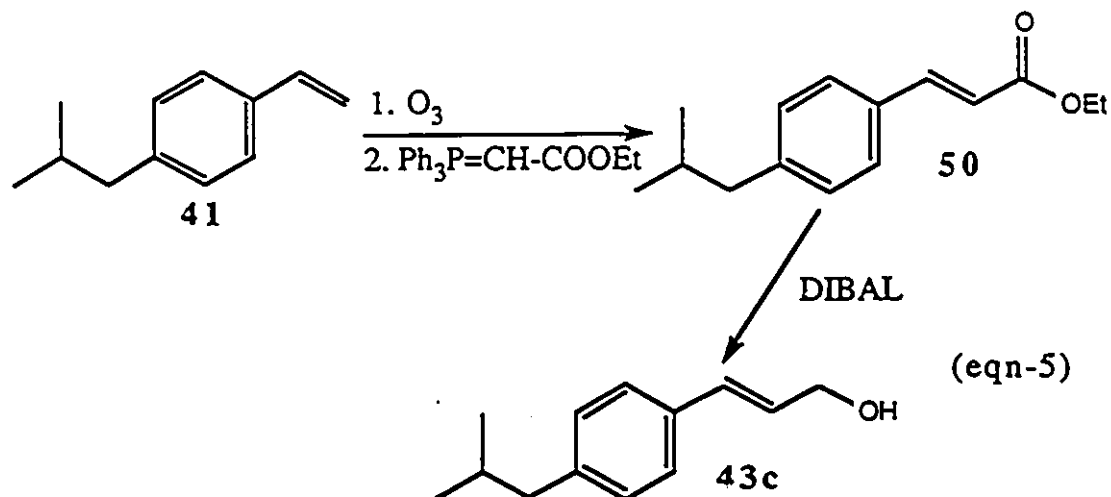

The allylic alcohols 43a, 43b and 43c were converted into the optically active epoxides 44a, 44b and 44c with enantiomeric excesses of 89 to 95% and yields ranging from 70 to 77% (Table II). The Sharpless epoxidation reaction is very air, moisture and temperature sensitive. Freshly distilled or purified allylic alcohols were dissolved in methylene chloride and t-butyl hydroperoxide in toluene was dried separately over molecular sieves for an hour before addition to the reaction mixture in order to achieve high enantiomeric excess of the product. L(+)-Diisopropyl tartrate obtained from Aldrich was distilled just prior to the reaction. All of the reactions were carried out at  $-20^{\circ}\text{C}$  under a nitrogen atmosphere.

Under regular catalytic Sharpless epoxidation conditions [6% DIPT and 5%  $\text{Ti}(\text{OiPr})_4$ ], the enantiomeric excess for the epoxide 44b was found to be 75%. By increasing the amount of DIPT from 6 to 12% and titanium isopropoxide from 5 to 10% the enantiomeric excess of the epoxide vastly improved to 94%. (Scheme 8)

Recrystallization of the epoxides **44a** and **44b** their increased enantiomeric purity to >98% from 95 and 94%, respectively.

Scheme 8

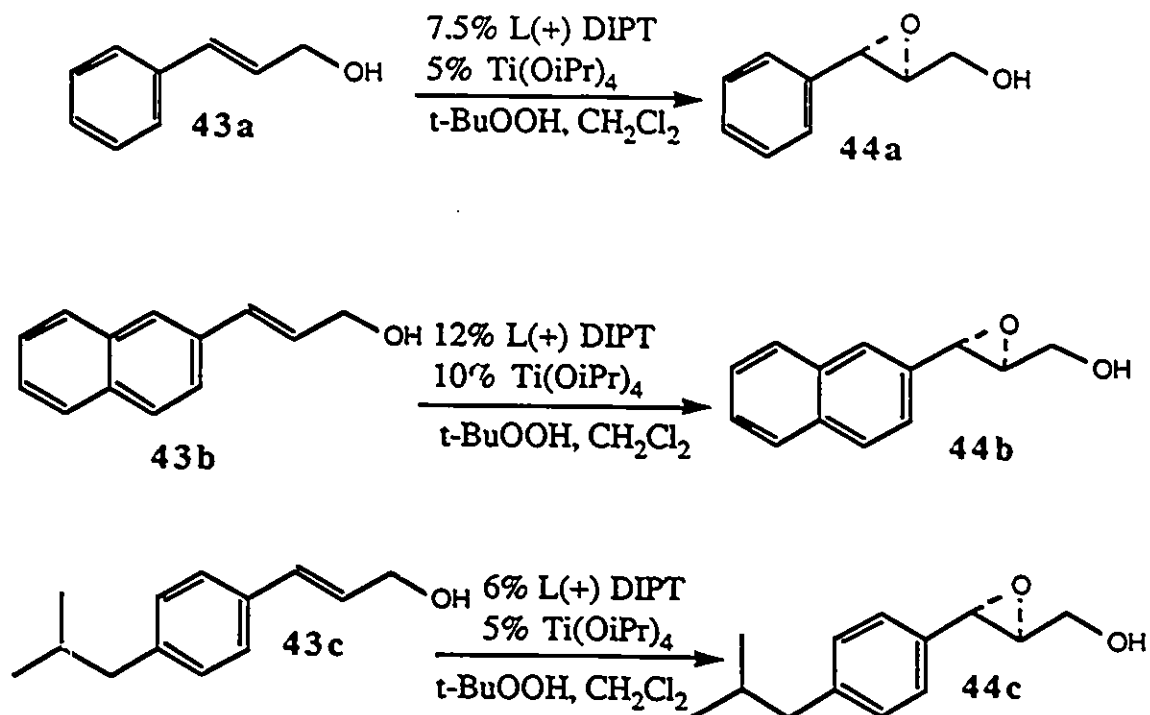

The enantiomeric excess of the epoxy alcohols **44a**, **44b** and **44c** was determined by use of <sup>1</sup>H NMR. The alcohols were first converted into the corresponding acetates **51a**, **51b** and **51c**. With addition of Eu(hfc)<sub>3</sub>, it was possible to determine the relative ratios of the enantiomers by simple integration of the methyl peak of the acetate. It was also possible, in the case of **44a**, to determine the enantiomeric excess by optical rotation. The enantiomeric excess obtained by this method was identical to that obtained using a chiral shift reagent.

<sup>1</sup>H NMR spectrum of compound 51a

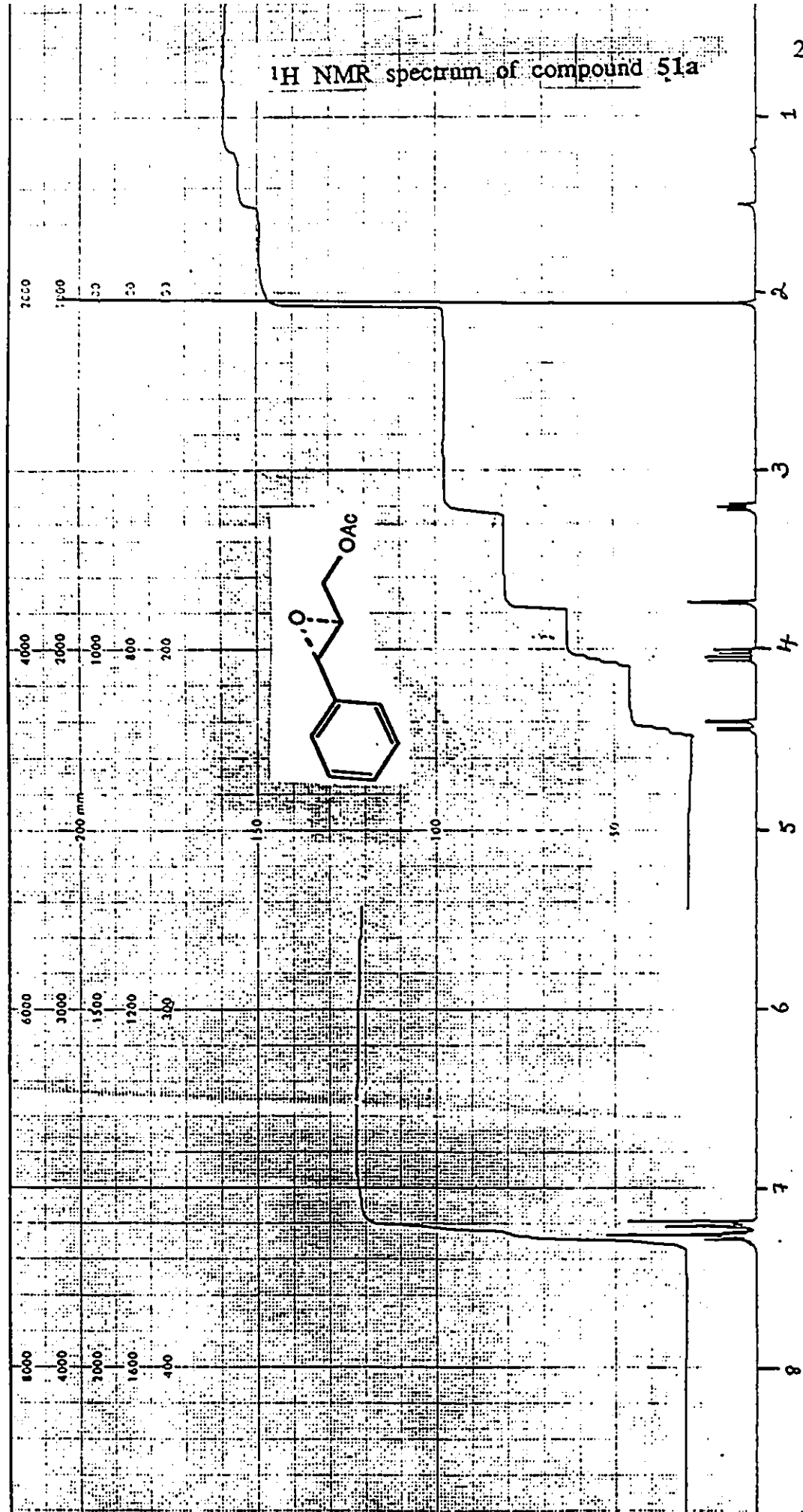

$^1\text{H}$  NMR spectrum of compound 51a with chiral shift reagent

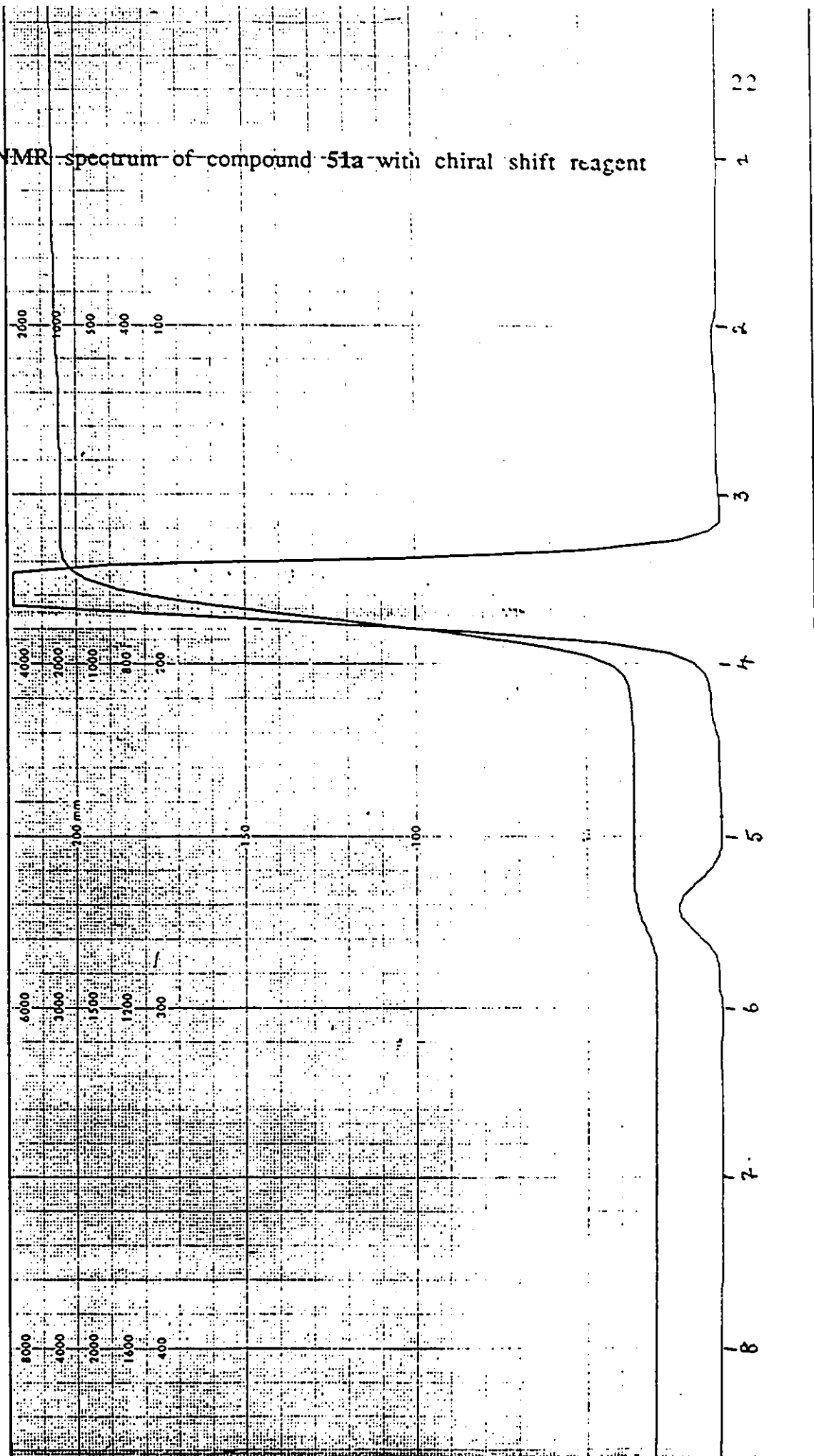

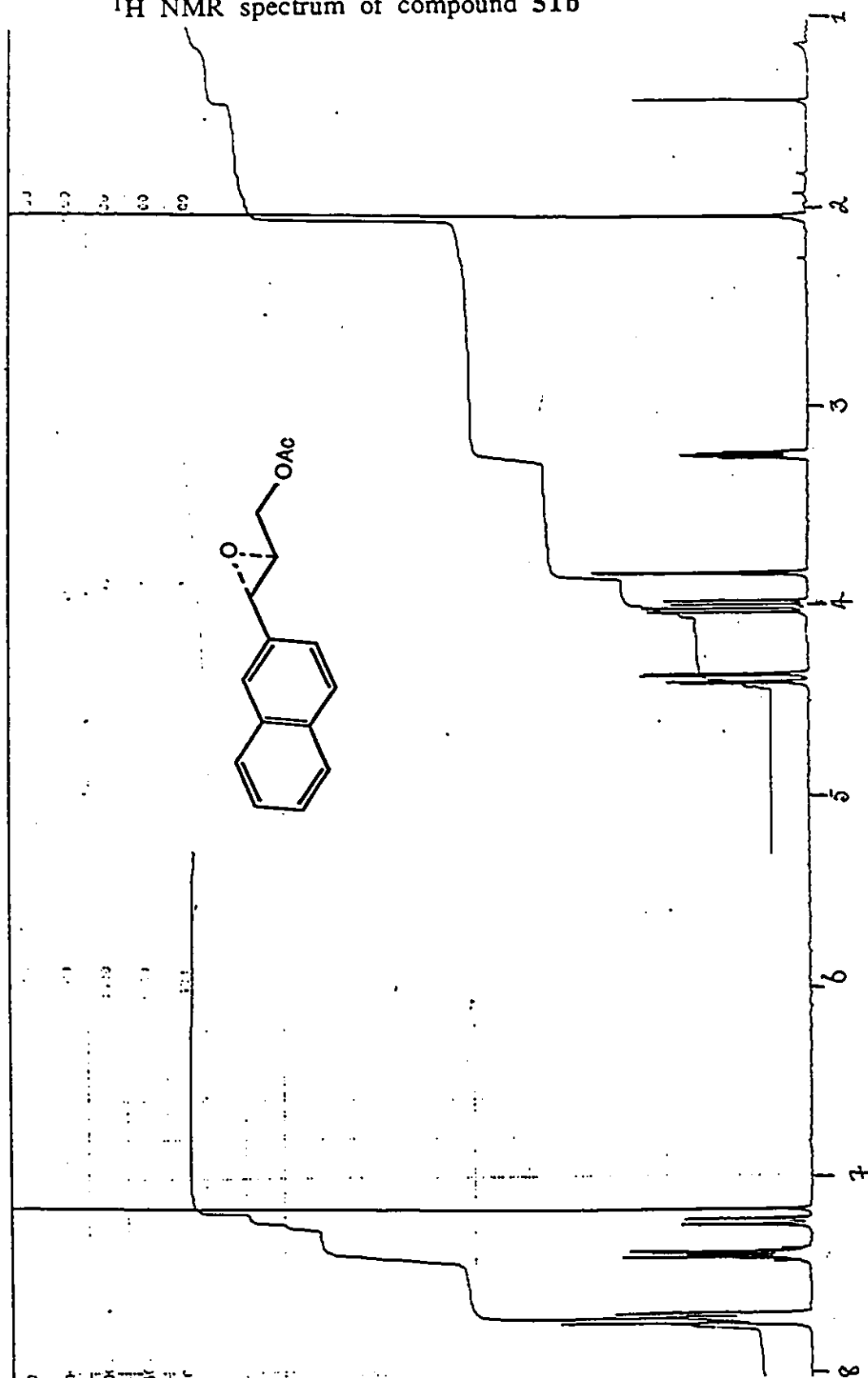
<sup>1</sup>H NMR spectrum of compound 51b

<sup>1</sup>H NMR spectrum of compound 51b with chiral shift reagent

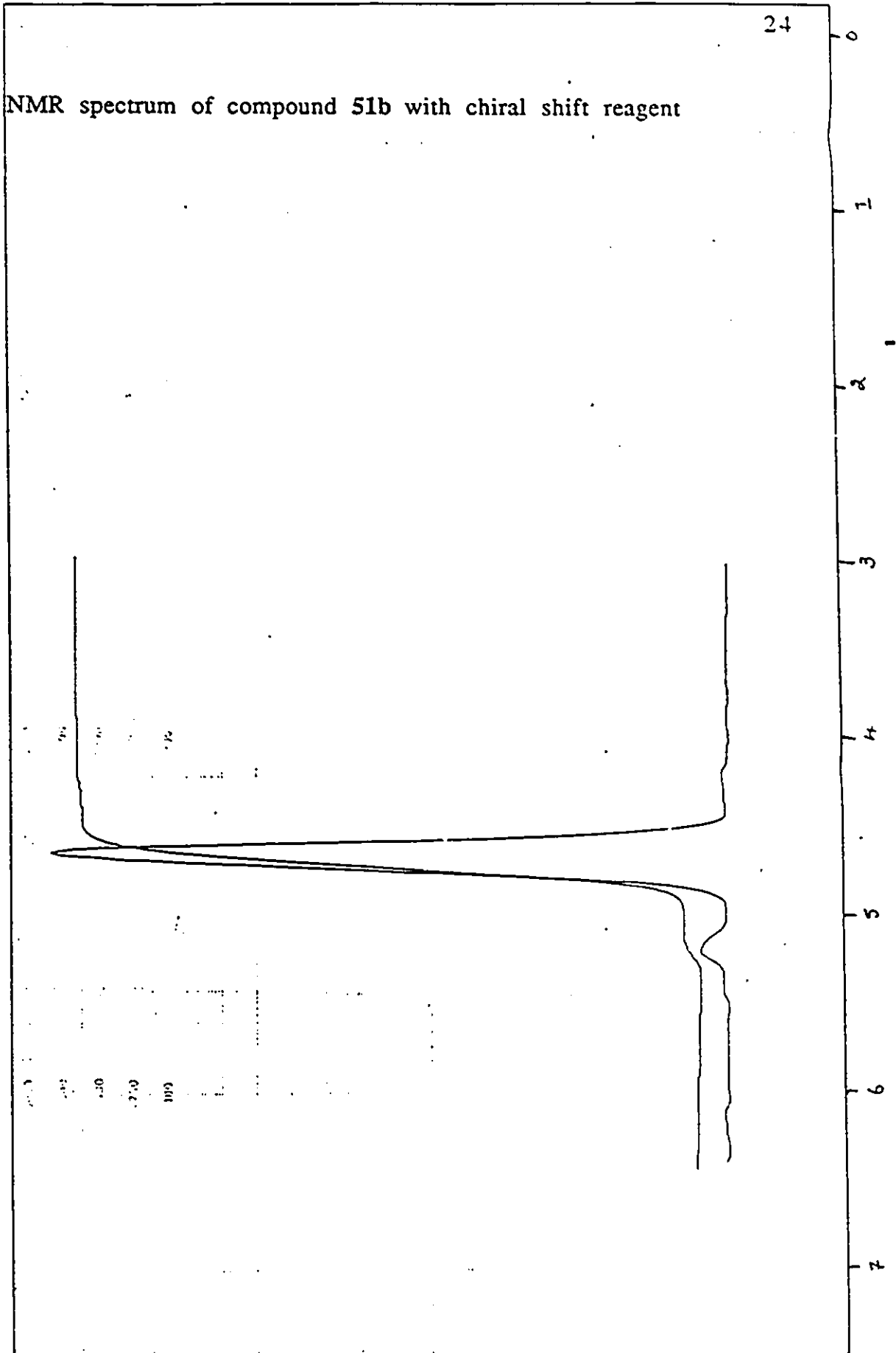

<sup>1</sup>H NMR spectrum of compound 51c

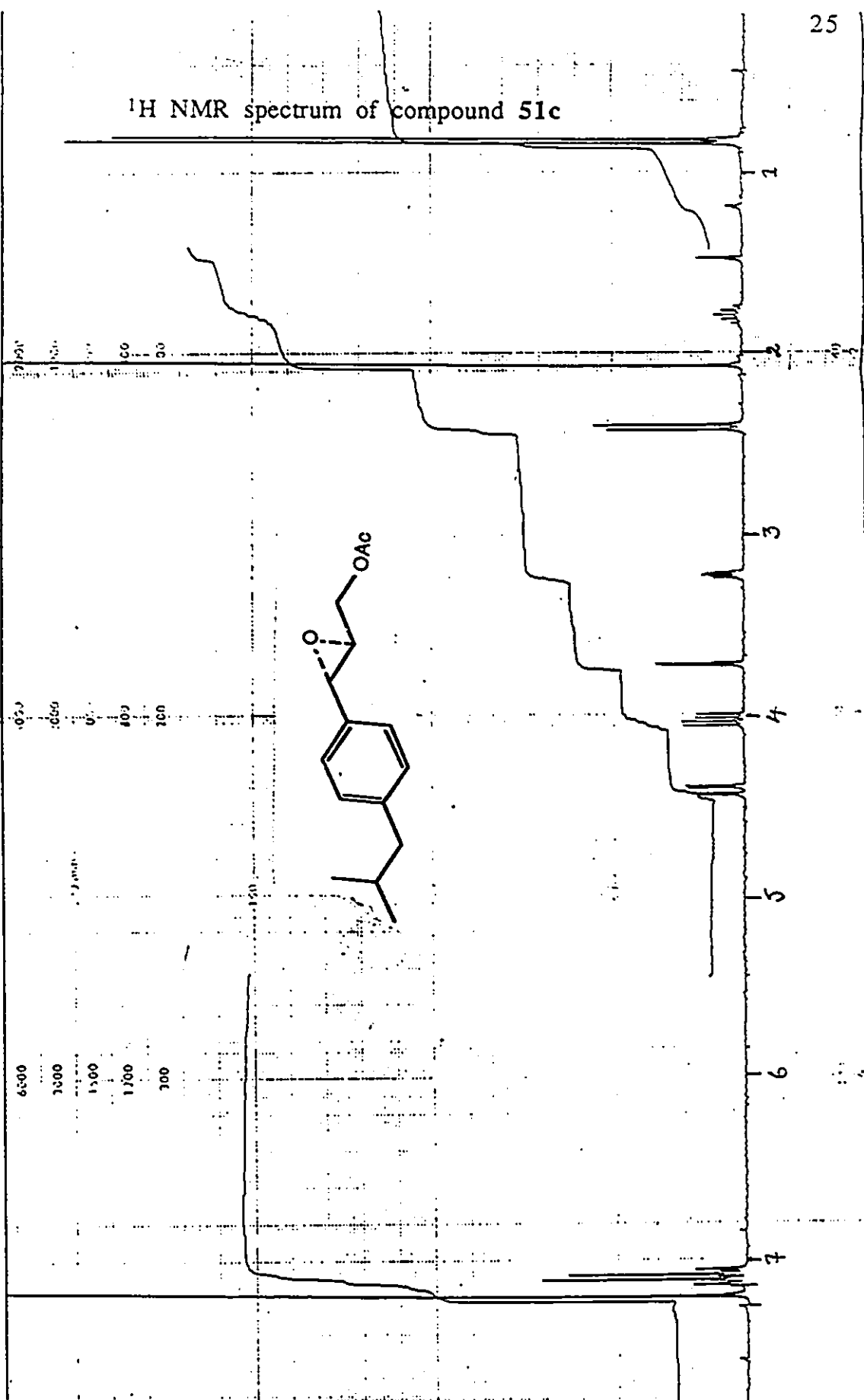

$^1\text{H}$  NMR spectrum of compound 51c with chiral shift reagent

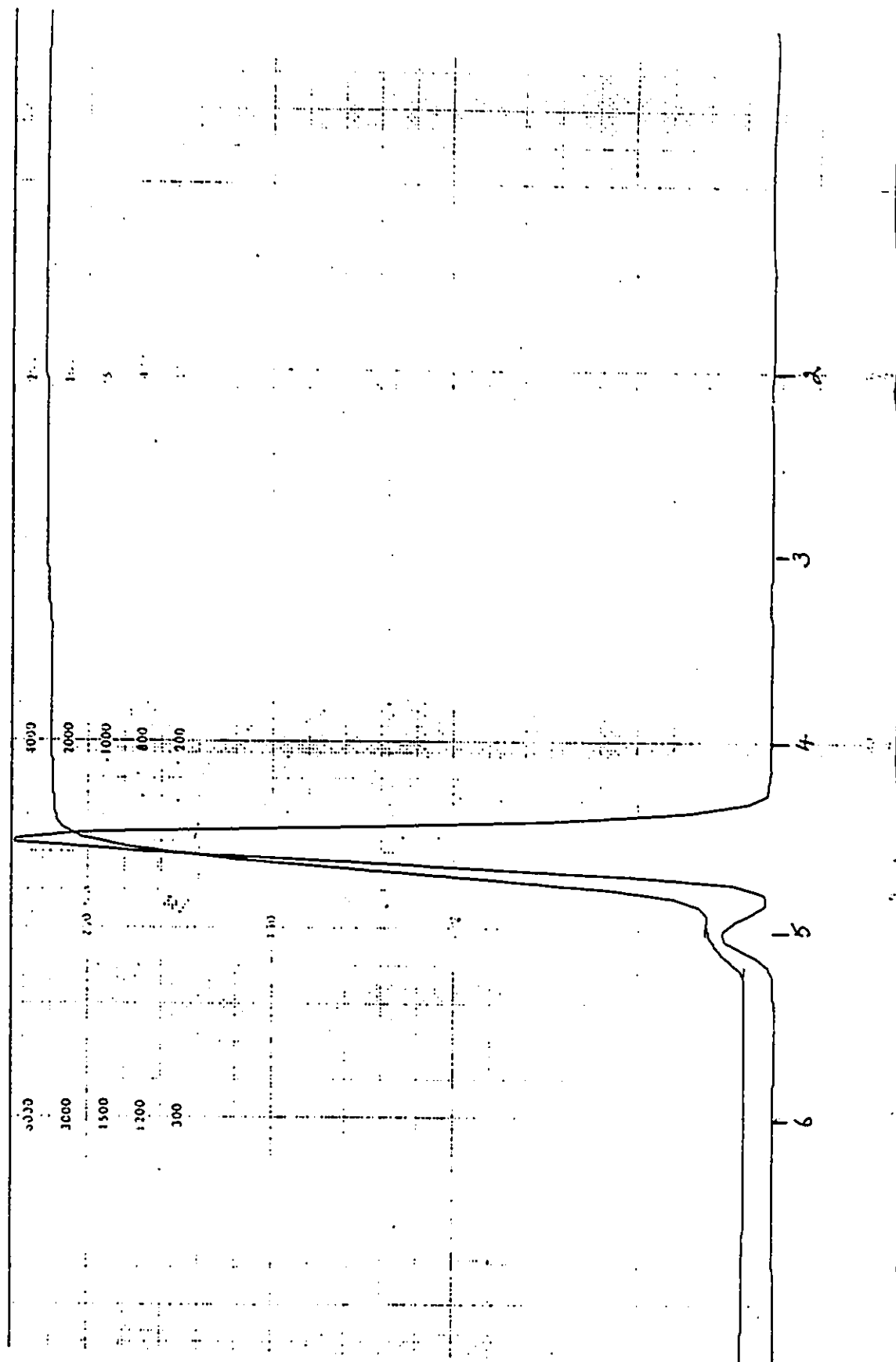

Scheme 9

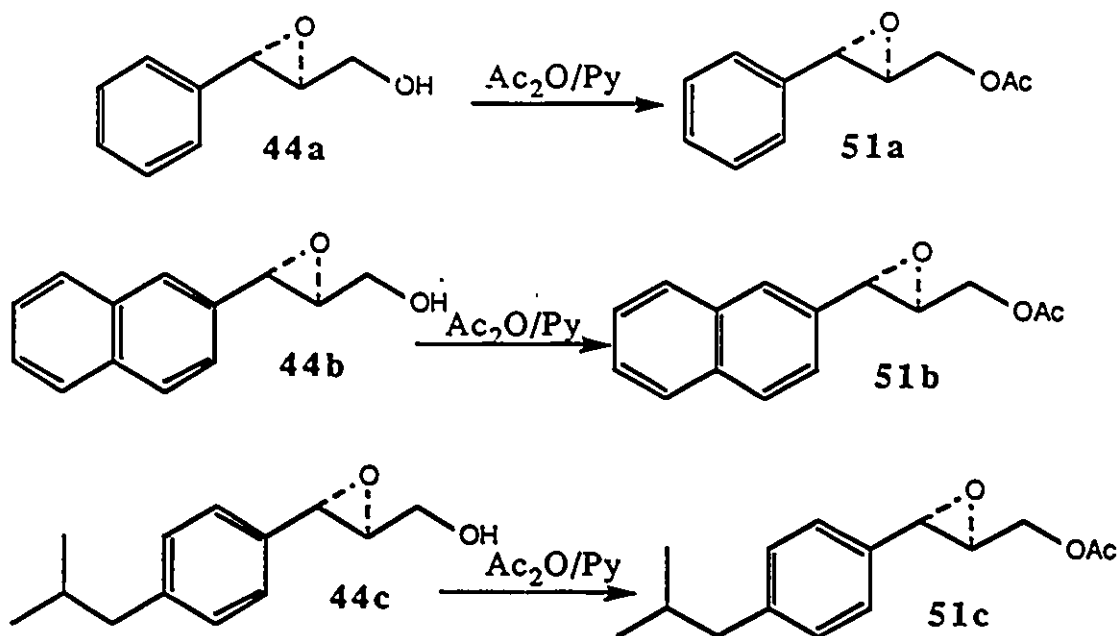

Treatment of the epoxy alcohols with trimethylaluminum in methylene chloride resulted in exclusive ring opening at the C-3 position to give the vicinal diols<sup>19</sup> in very high yields. In each of the three cases studied ring opening occurred mainly with retention of configuration at the benzylic center giving 45a, 45b and 45c accompanied by small amounts of inverted diol 46a, 46b and 46c (Scheme 10). The non-stereospecific ring opening suggests that the trimethylaluminum reaction occurs with considerable carbocation character at the benzylic position which allows for the possibility of rotation around the  $\text{C}_2\text{-C}_3$  C-C bond.

Scheme 10

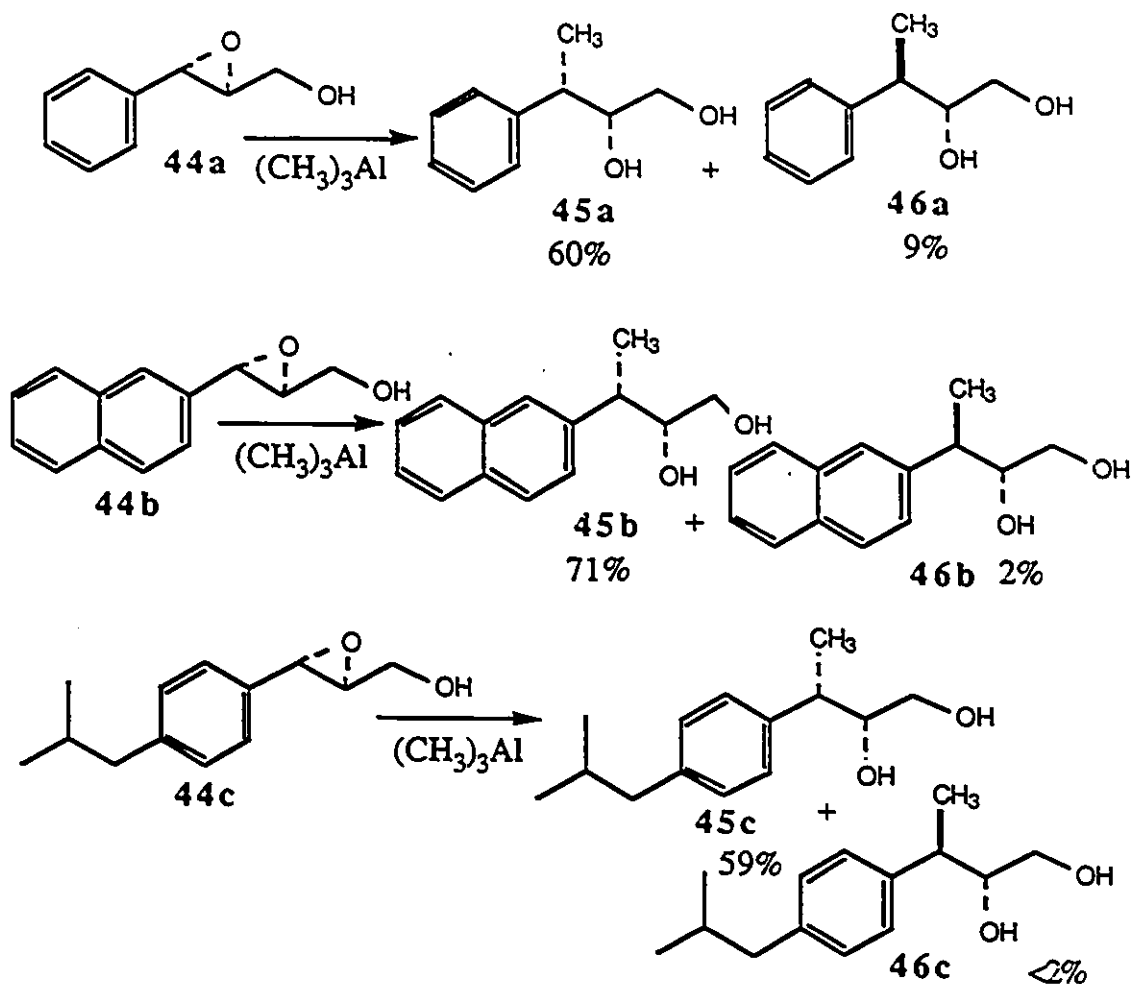

Finally, these vicinal diols were converted into the 2-aryl propionic acids 47a, 47b and 47c, by addition of a catalytic amount of ruthenium (III) chloride and 4.5 equivalent of periodic acid<sup>20</sup> (method a, in Scheme 11). When this method failed in the case of 45b, a modified procedure of Masamune's oxidation<sup>21</sup> was used. Sodium periodate and potassium permanganate were used as oxidizing agents (method b, in Scheme 11).

## Scheme 11

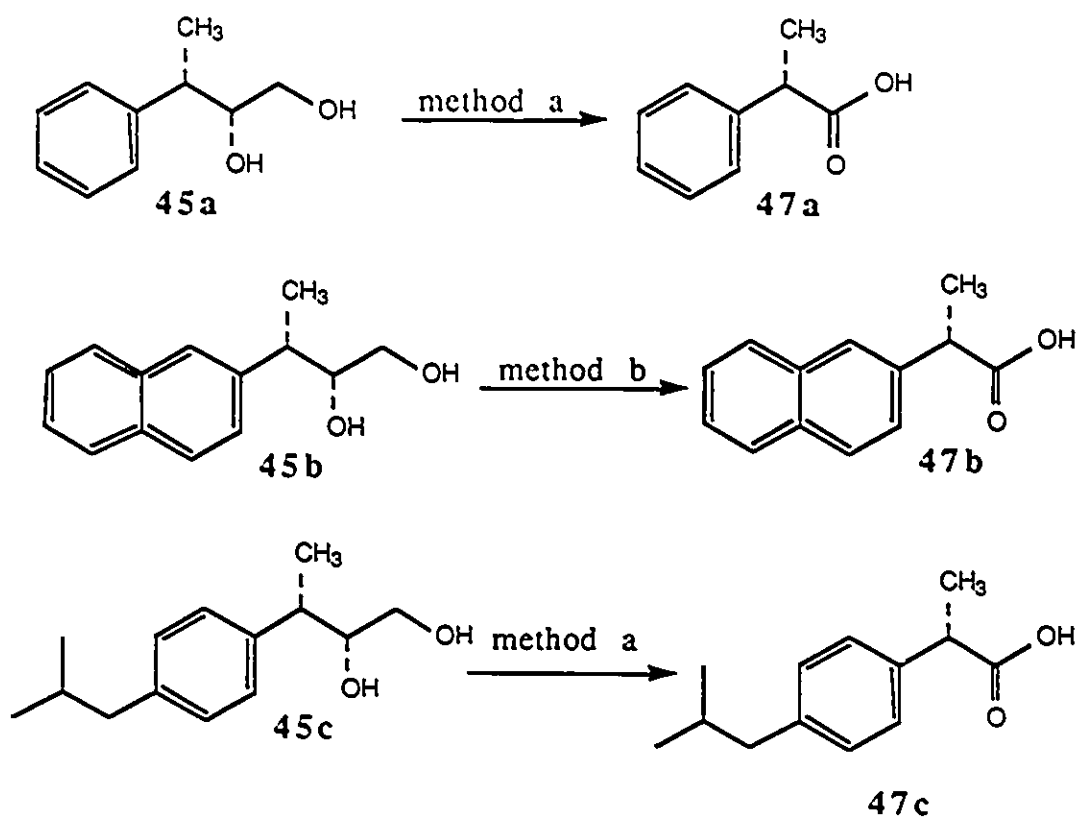

method a:  $\text{H}_5\text{IO}_6$ , cat.  $\text{RuCl}_3$

method b:  $\text{NaIO}_4$ ,  $\text{KMnO}_4$

The enantiomeric excesses of the products 47a, 47b and 47c were determined both by optical rotation and  $^1\text{H}$  NMR using chiral shift reagents. The acids were first converted into the corresponding esters 48a, 48b and 49c. With addition of  $\text{Eu}(\text{hfc})_3$ , it was possible to determine the relative ratios of the enantiomers by simple integration of the methyl group present on  $\alpha$  carbon to the ester.

<sup>1</sup>H NMR spectrum of compound 48a

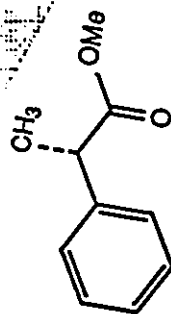
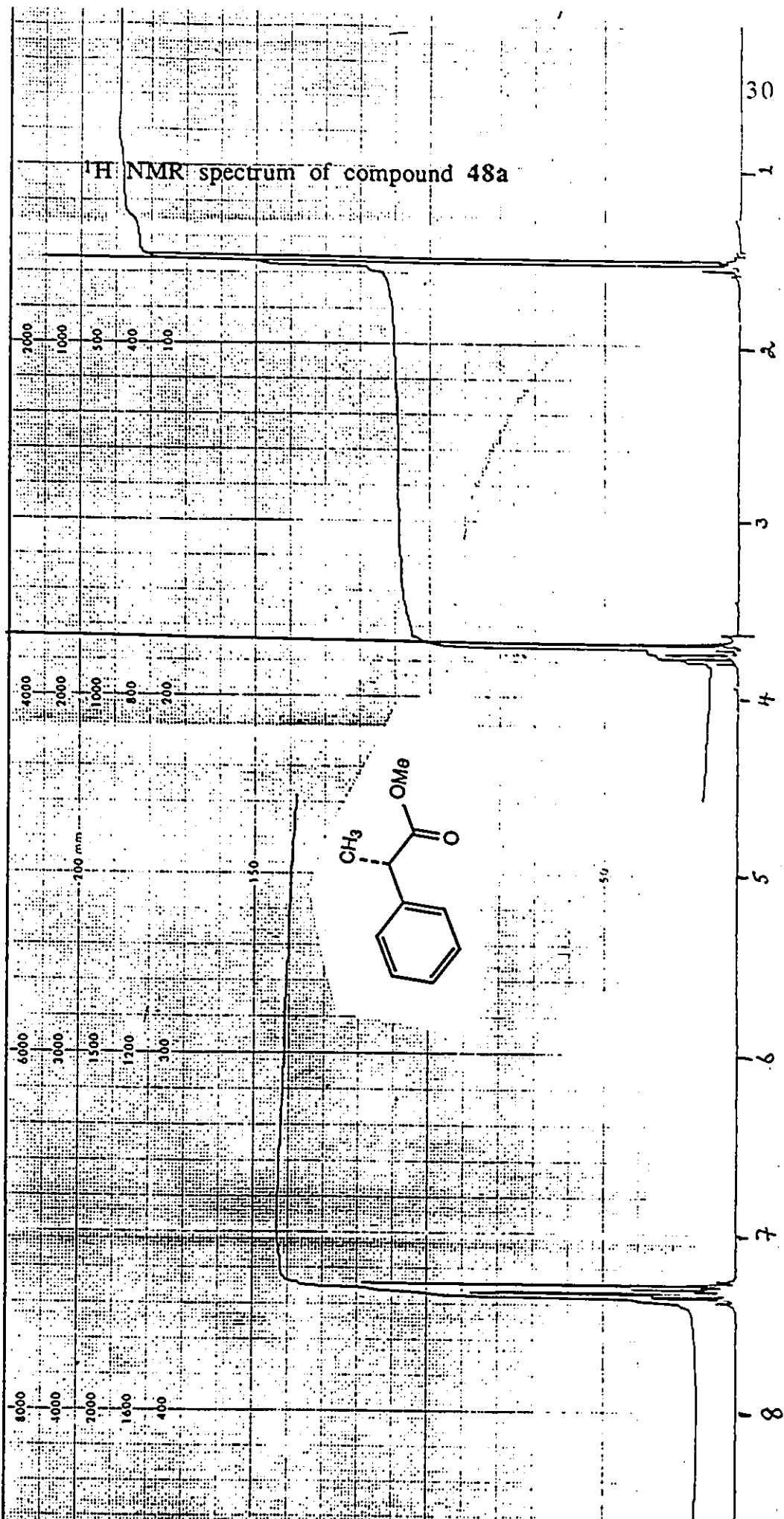

<sup>1</sup>H NMR spectrum of compound 48a with chiral shift reagent

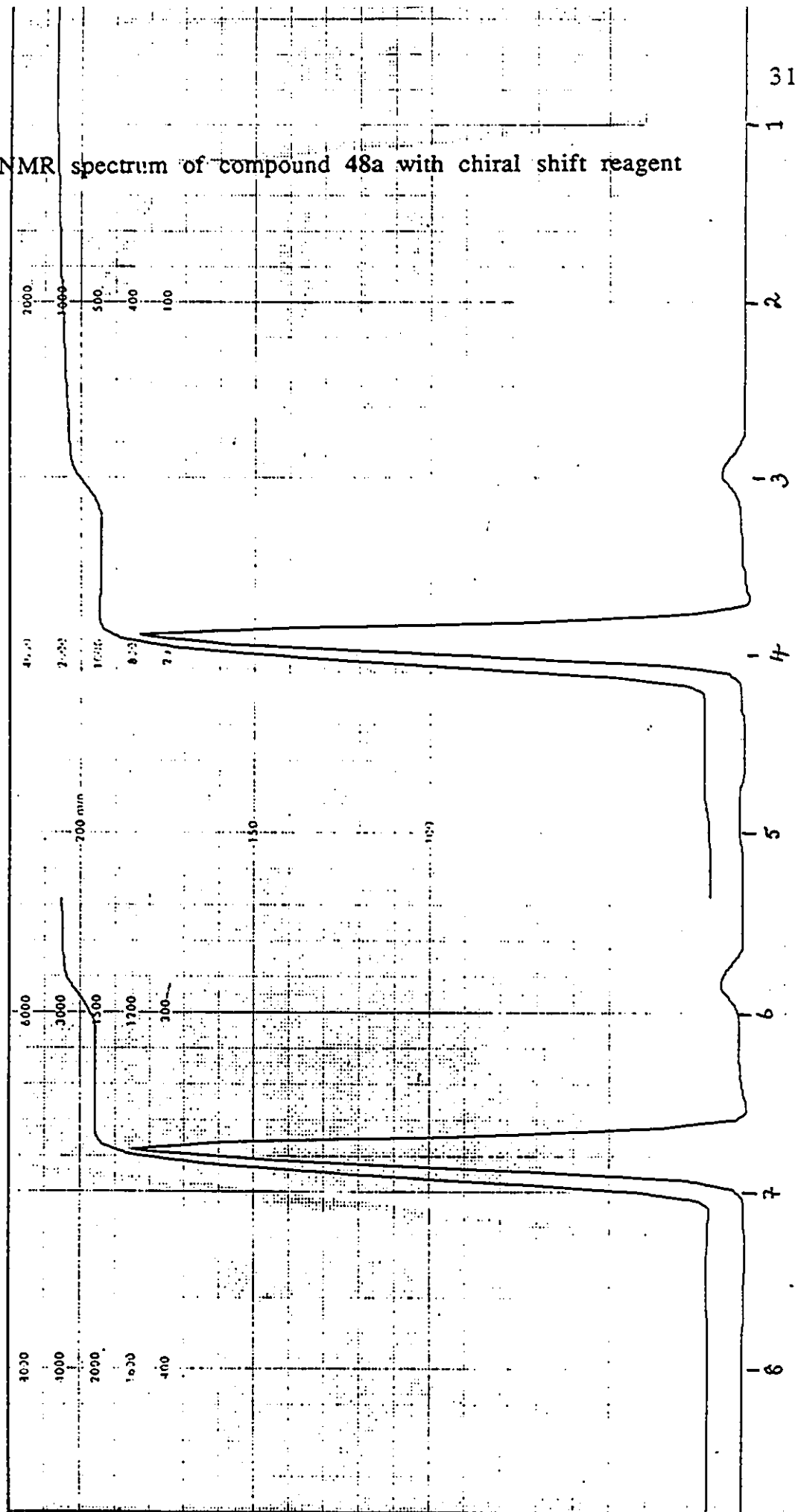

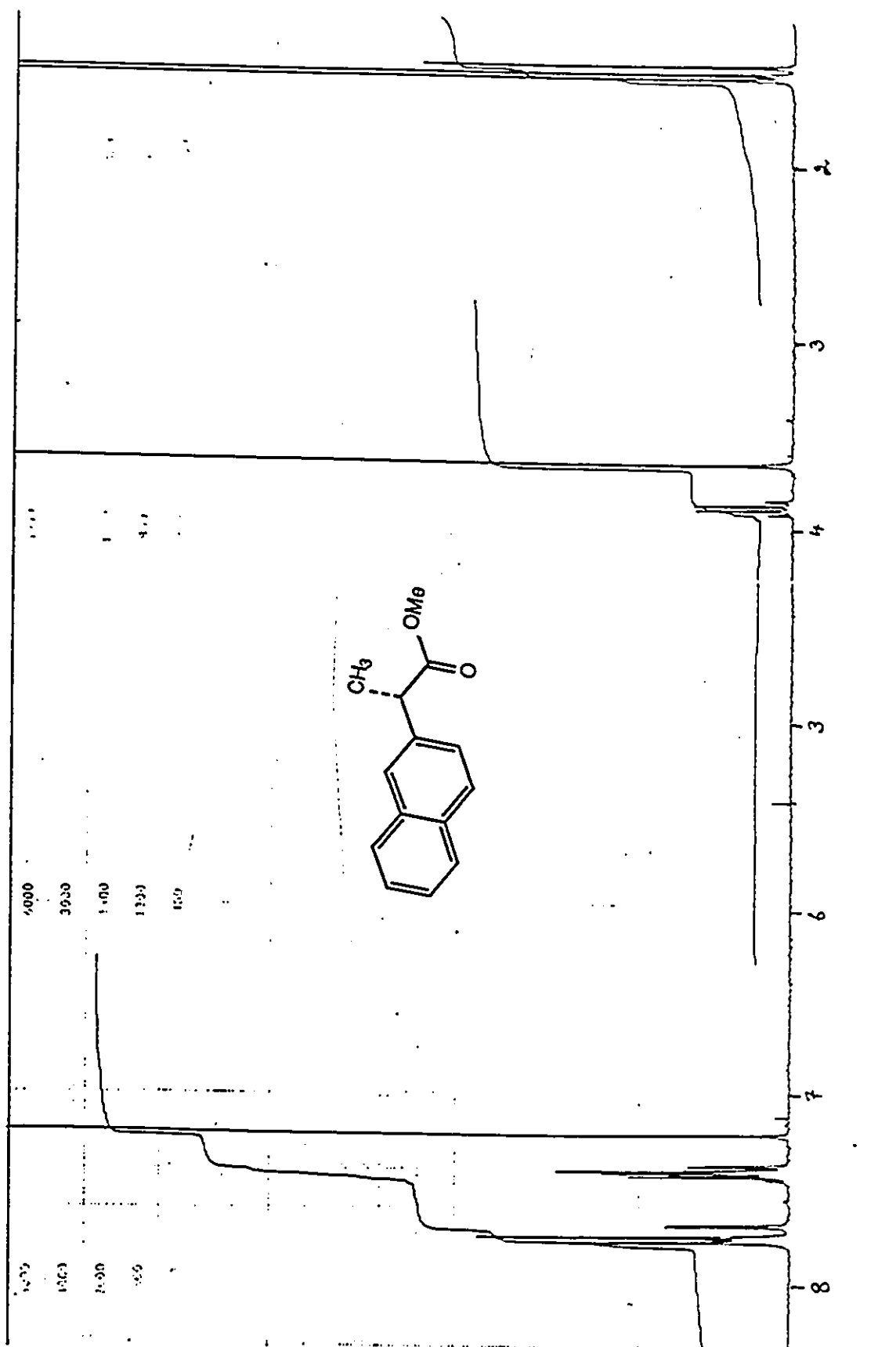
$^1\text{H}$  NMR spectrum of compound 48b

$^1\text{H}$  NMR spectrum of compound 48b with chiral shift reagent

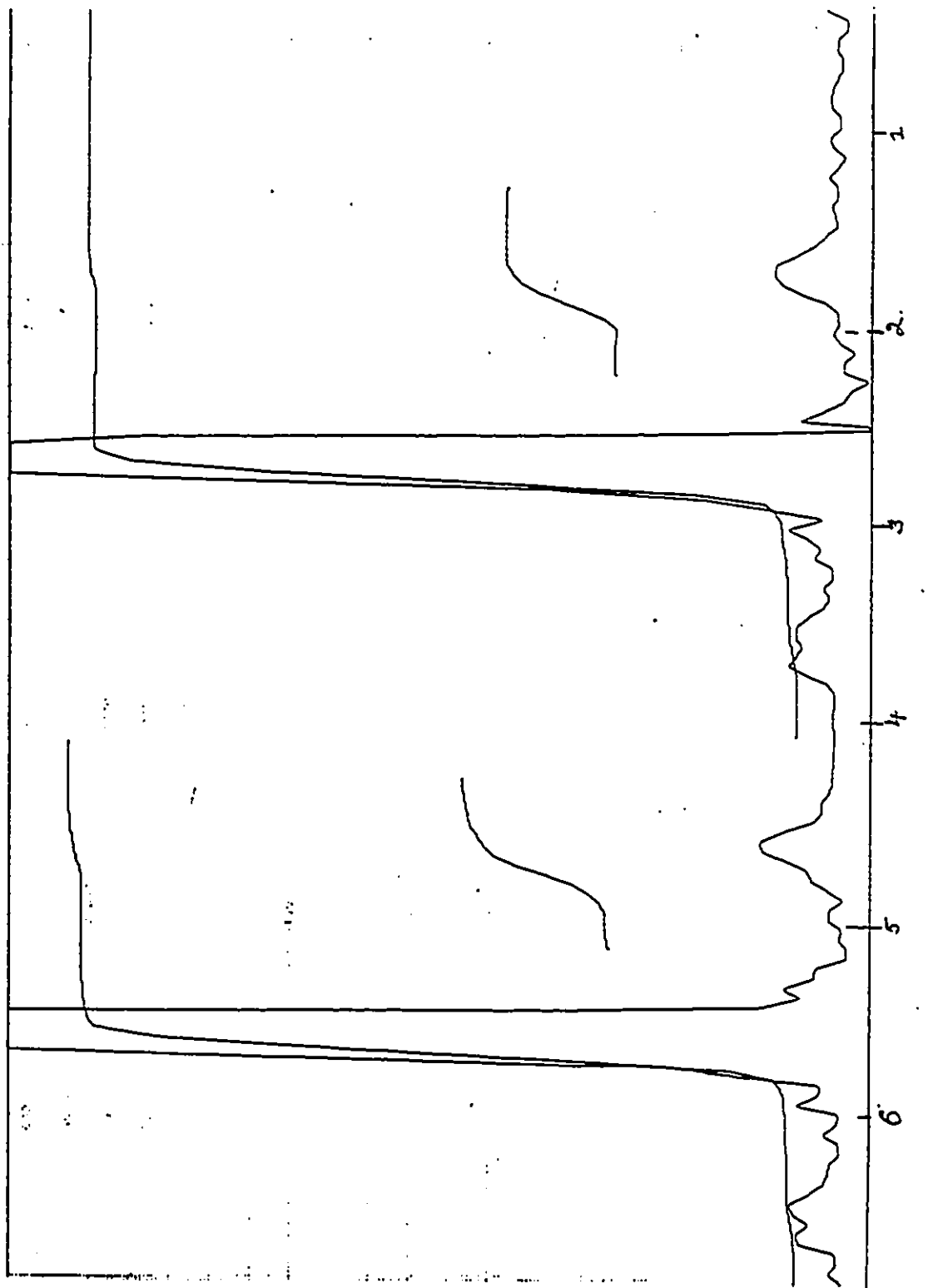

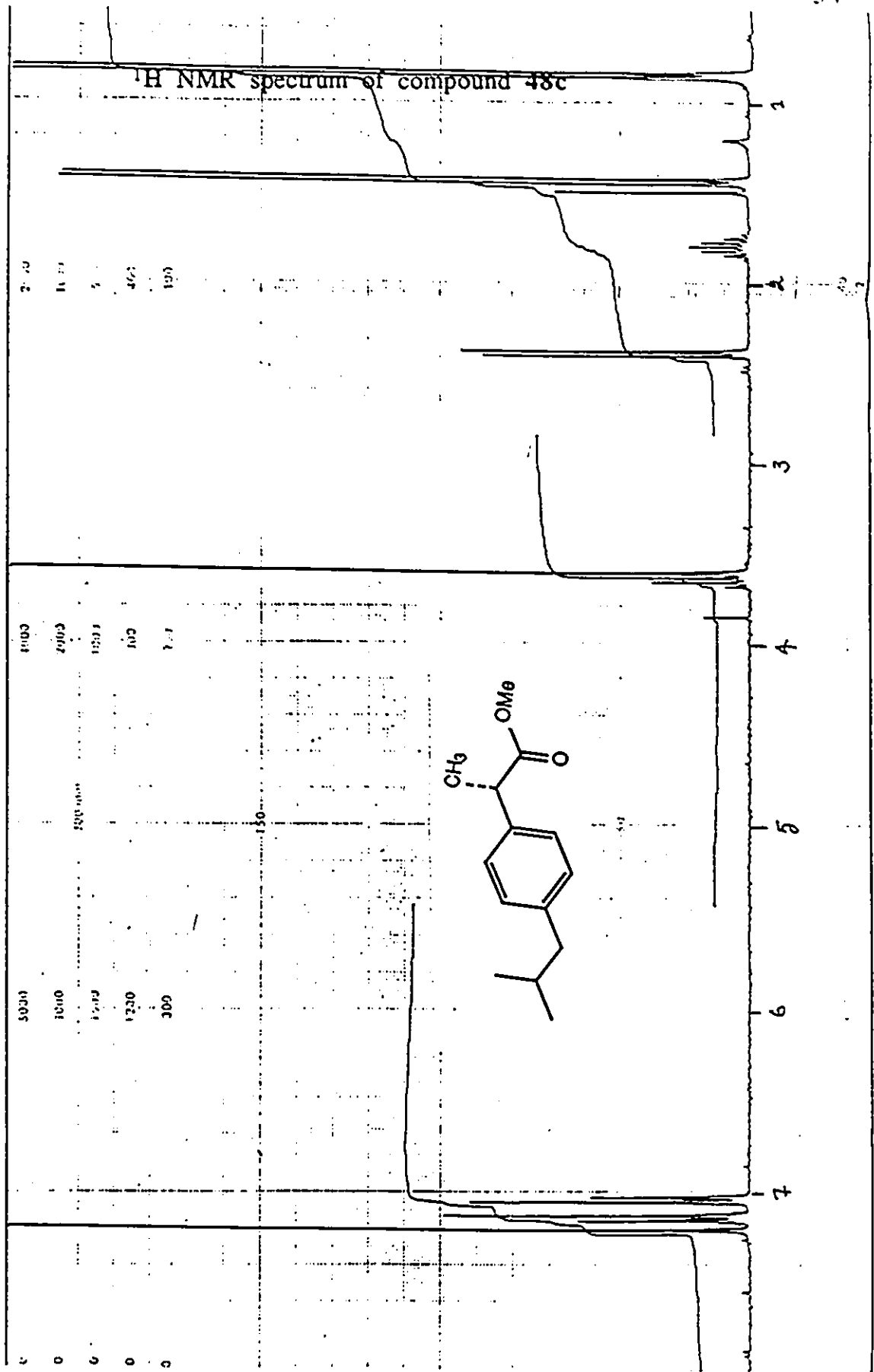

$^1\text{H}$  NMR spectrum of compound 48c with chiral shift reagent

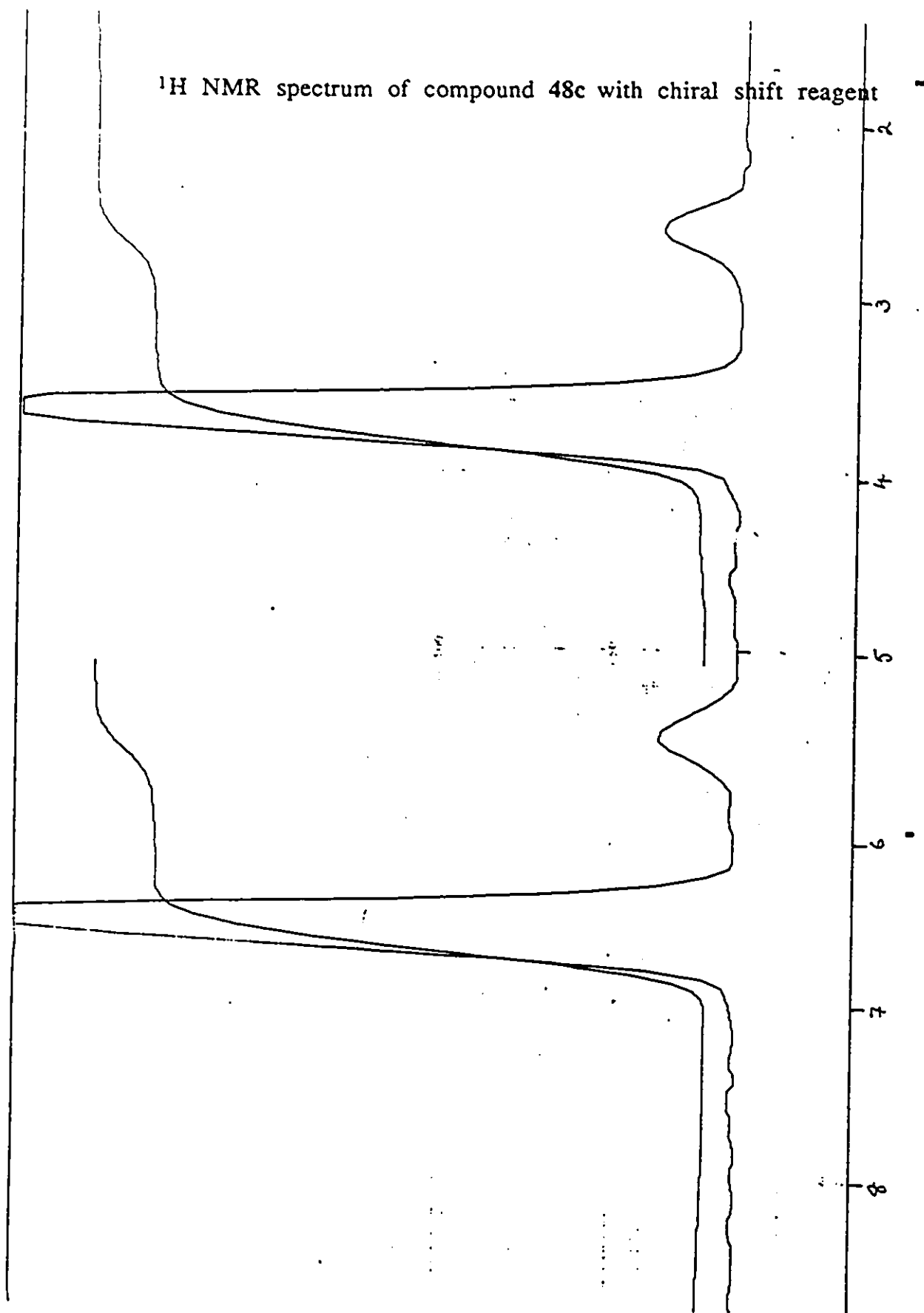

In conclusion, Sharpless epoxidation products were indeed obtained in high enantiomeric excess as we had expected. Sodium azide and trimethylaluminium opened the epoxide ring preferentially at C<sub>3</sub> over C<sub>2</sub> in order to prepare  $\alpha$ -amino acids and 2-arylpropionic acids. One could also synthesize  $\alpha$ -mercapto carboxylic acids by using thiol acetate anion as a nucleophile as is illustrated in Scheme 2.

Table II

compound	yield(%)	<sup>1</sup> HNMR(CDCl <sub>3</sub> /TMS) <sup>a</sup> δ,J(Hz)	ee% <sup>b</sup>
44a	77	7.2(m, 5H); 4.08(ddd, 1H, J=12.8, 2.4, 5); 3.90(d,1H, J=2.05); 3.77(ddd, 1H, J=12.8, 7.7, 3.8); 3.2(m,1H); 2.1(br,1H)	95 (93, c 2.4, CHCl <sub>3</sub> , [α] <sup>25</sup> <sub>D</sub> -47.08 ref <sup>2</sup> )
44b	73	7.2-7.8(m, 7H); 4.08 (m, 2H);3.84(ddd, 1H, J=3.7, 7.9, 12);3.31(ddd, 1H, J=3.7, 2.3, 2.3);1.84(b, 1H)	94 (c 0.75, CHCl <sub>3</sub> , [α] <sup>25</sup> <sub>D</sub> -49.6)
44c	71 <sup>c</sup>	7.17(d, 2H, J=8.1); 7.1(d, 2H, J= 8.1); 3.88(ddd, 1H, J=12.8,4.7, 2.4); 3.8(d, 1H, J=2.2);3.7(ddd, 1H, J=12.5, 7.4,3.7); 3.2(ddd, 1H, J=3.8, 2.3,2.3);2.45(d, 2H, J=7.2); 1.8(h, 1H, J=7); 0.87(d,6H, 7)	88.4 (c 3.0, CHCl <sub>3</sub> , [α] <sup>25</sup> <sub>D</sub> -26.43)
45a	60(69.6) <sup>d</sup>	7.26(m, 5H); 3.71(m, 1H); 3.3(m, 2H); 2.762(q, 1H, J=7)1.31(d, 3H, J=7)	f
45b	71(73.8) <sup>d</sup>	7.25(m,7H) 3.75(ddd,1H, J=7.8, 7.69, 3.14); 3.463(ddd, 1H, J=11.1, 3.12); 3.34(dd,1H, J=11.1, 7.5); 2.79(q, 1H, J= 7); 1.840(d, 3H, J=7)	f

45c	59(61) <sup>d</sup>	7.06(s, 4H); 3.73(m, 1H); 3.43(m, 1H); 3.33(m, 1H); 2.76(q, 1H, J=7); 2.42(d, 1H, J=7); 1.89(h, 1H, J=7); 1.33 (d, 1H, J=7); 0.81(d, 6H, J=7)	f
47a	77(70) <sup>e</sup>	7.3(s, 5H); 3.71(q, 1H, J=7); 1.49(d, 3H, J=7)	91 (89, c 3.108, EtOH, $[\alpha]_{25}^D +71.9$ ref. <sup>22</sup> )
47b	62(0) <sup>e</sup>	7.77(m, 4H); 7.4(m, 3H); 3.39(q, 1H J=7); 1.59(d, 3H, J=7)	97 (98, c 2.5, CHCl <sub>3</sub> , $[\alpha]_{25}^D$ +66.4, ref. <sup>15</sup> )
47c	27(47) <sup>e</sup>	7.2(d, 2H, J=8); 7.08(d, 2H, J=8); 3.69(q, 1H, J=7); 1.81 (h, 1H, J=7); 1.48(d, 3H, J=7); 0.87(d, 6H, J=7)	81 (85, c=4.9, CHCl <sub>3</sub> , $[\alpha]_{25}^D$ +39.9, ref. <sup>23</sup> )

<sup>a</sup> <sup>1</sup>H NMR spectra were recorded using Varian 200MHz or 300MHz spectrometers.

<sup>b</sup> The epoxy alcohols were converted into the epoxy acetates by treatment with acetic anhydride and pyridine. The ee's were determined with an accuracy of  $\pm 3\%$  by <sup>1</sup>H NMR observation of the acetate peak using Eu(hfc)<sub>3</sub>. The acids were converted to esters by treatment with diazomethane. The ee's were determined by using Eu(hfc)<sub>3</sub> and observing the doublet of the CH<sub>3</sub> in the ester derivative. ee's in parentheses were determined on the basis of literature  $[\alpha]_D$  values.

<sup>c</sup> The percentage yield is based on starting material consumption.

<sup>d</sup> The total yield, i.e.(2+3)

<sup>e</sup> The percentage yield using method(b).

<sup>f</sup> No ee's were determined for these compounds.

Larsen<sup>18</sup> et al described in their article (Scheme 6) that a polar keto group  $\alpha$  to the hydroxyl group of the chiral alcohol is necessary in order to obtain high diastereoselection (85% yield, >94% ee). On the basis of this information we decided to try quinine 53 as a possible chiral auxiliary. The distance between the OH group and the polar amino group in 53 is similar to that between the OH and the carbonyl function in pantolactone or benzyl lactate. Intramolecular hydrogen bonding exists in all three compounds and thus we rationalized that 53 might react with the ketene generated *insitu* with high diastereofacial selectivity.

Therefore we treated the acid chloride 52, with two equivalents of 53, in methylene chloride. Two diastereomers were obtained in a ratio of 4:1. See Scheme 12. The ratio of the diastereoisomer was obtained by measuring the integration of the methyl peak for each of the diastereoisomers by <sup>1</sup>H NMR. No efforts have been made to isolate or to identify the absolute stereochemistry of the diastereoisomers.

Larsen<sup>18</sup> showed that the use of non polar solvents such as hexane or toluene increases the diastereoisomer ratio. Quinine is insoluble in hexane thus we were unable to exploit this information. One could possibly carry out the above mentioned reaction in hexane by changing from quinine to other amino alcohols derived from optically active  $\alpha$ -amino acids. Further studies in this area are in progress in our labs.

Scheme 12

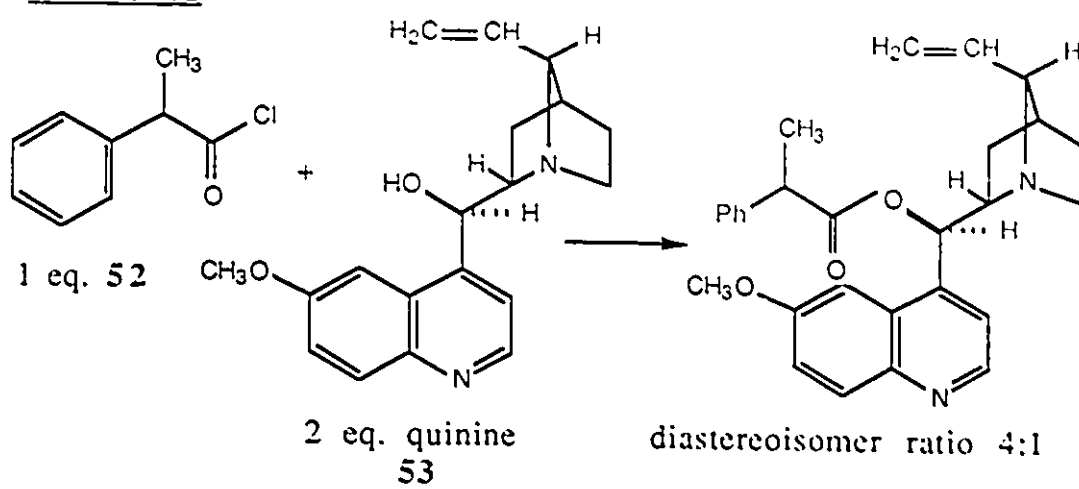

## Experimental Section

### (E)-3-(2-naphthyl)-2-propenol 43b

(Carbethoxymethylene) triphenylphosphorane (13.4 g, 38.4 mmol) was added to a solution of 5 g (31.8 mmol) of 2-naphthaldehyde in 125 mL of THF. The reaction mixture was allowed to reflux for 3 h. After checking for completion by TLC the solution was concentrated. Approximately 30 mL of hexane was added, and the triphenylphosphine oxide which precipitated out was filtered off. Evaporation of the solvent provided 8 g of ester. It was used for the next step without further purification.

DIBAL (70mL, 1M) was added to a stirred solution of (30.9 mmol) of ester in 100 mL of dry methylene chloride at  $-78^{\circ}\text{C}$  under a nitrogen atmosphere. The reaction mixture was allowed to warm up to room temperature and was stirred for 2 h. The reaction mixture was cooled to  $-78^{\circ}\text{C}$  and  $\sim 5$  mL of EtOH was added dropwise. 10% HCl was added at  $0^{\circ}\text{C}$ . The reaction mixture was extracted with  $\text{CH}_2\text{Cl}_2$ . The organic layer was separated and washed with 25 mL of saturated NaCl solution, dried, and evaporated to give 4.7 g(82%) of 43b.

$^1\text{H NMR}$  ( $\text{CDCl}_3$ )  $\delta$  4.37( $\text{d}^{\ddagger}$ , 2H,  $J=1.4, 5.7$  Hz), 6.48(dd, 1H,  $J=5.7, 15.9$  Hz), 6.77(d, 1H,  $J=15.9$  Hz), 7.43(m, 2H), 7.59(dd, 1H,  $J=1.7, 8.5$ ), 7.77(m, 4H); ei-MS  $m/z$  184( $\text{M}^+$ , 85%), 165( $\text{M}^+-19$ , 40%), 150( $\text{M}^+-43$ , 100%).

(E)-3(4-isopropylphenyl)-2-propenal 43c

Ozone was bubbled through a stirred solution of 2.75 g of p-isobutylstyrene in 50 mL of dry  $\text{CH}_2\text{Cl}_2$  at  $-78^\circ\text{C}$  under nitrogen atmosphere until the solution turned blue.(30 minutes) Immediately, 4.5 g of triphenyl phosphine was added, and the solution became colourless. Due to the unstable nature of the aldehyde, 13.1 g of (carbethoxymethylene) triphenylphosphorane was added to the reaction mixture. The solution was concentrated and 75 mL of THF was added. The reaction mixture was gently refluxed over a period of 3 h and then once again concentrated to 25 mL. Hexane (30 mL) was added and triphenylphosphine oxide was filtered off to give the crude product. Purification by flash chromatography using 40:1:1 hexane: ether: ethyl acetate as the solvent system provided 2.4 g (60% yield for two steps) of 50.

DIBAL (7.91 mL, 44 mmol) was added to a stirred solution of 4.7 g (20.2 mmol) of ester in 60 mL of  $\text{CH}_2\text{Cl}_2$  at  $-78^\circ\text{C}$  under nitrogen atmosphere. The reaction mixture was allowed to warm up to room temperature and was stirred for 3 h. The reaction mixture was cooled to  $-78^\circ\text{C}$  and 5 mL of EtOH was added dropwise. After warming to  $0^\circ\text{C}$ , 10% dil HCl was added to acidify the solution. The organic layer was washed with saturated sodium chloride solution, dried and evaporated to give 3.6 g of product. On purification by flash chromatography using hexane: EtOAc (5:1) as a solvent system, 2.8 g (73%) of pure material 43c was obtained.

$^1\text{H}$  NMR ( $\text{CDCl}_3$ )  $\delta$  7.2(d, 2H,  $J=8.1$  Hz), 7.0(d, 2H,  $J=8.1$  Hz), 6.5(d, 1H,  $J=16$  Hz), 6.3(dd, 1H,  $J=16, 5.7$  Hz), 4.2(m, 2H), 2.4(d, 2H,  $J=7.1$  Hz),

1.8(m, 1H), 0.8(d, 6H, J=6.6 Hz); IR (neat)  $\text{cm}^{-1}$  3300, 2940; ei-MS  $m/z$  190( $\text{M}^+$ , 37%), 147( $\text{M}^+-43$ , 100%).

(2S-trans)-3-phenyloxiranemethanol 44a (epoxycinnamyl alcohol)

Flame dried 0.5 L three necked flask was fitted with a thermometer and a dropping funnel. L(+)-Diisopropyl tartrate (0.655 g, 2.8 mmol) was added to 350 mL of  $\text{CH}_2\text{Cl}_2$  in the flask. The mixture was cooled to  $-20^\circ\text{C}$  and 2g of activated powdered 4A molecular sieves, 0.55 mL (1.9 mmol) of  $\text{Ti}(\text{OiPr})_4$  and 21.5 mL of a 3.5 M tertiary-butyl hydroperoxide in toluene were added sequentially. The resulting mixture was allowed to stir at  $-20^\circ\text{C}$  for 1 h. A solution of 5.08 (37.3 mmol) cinnamyl alcohol in 25 mL of methylene chloride was added dropwise to the mixture over a period 1 h. Prior to the addition, the cinnamyl alcohol was dissolved in  $\text{CH}_2\text{Cl}_2$  and dried over 3A molecular sieves for 30 minutes. Stirring was continued for 8 h at  $-20^\circ\text{C}$ .

The reaction mixture was quenched at  $-20^\circ\text{C}$  with 3 mL of a 10% aqueous solution of sodium hydroxide saturated with sodium chloride. Ether (35 mL (10% v/v)) was added and the cold bath was removed. The reaction mixture was allowed to warm to  $+10^\circ\text{C}$ . Stirring was maintained at  $+10^\circ\text{C}$  for 10 minutes, after which 3 g of  $\text{MgSO}_4$  and 0.3 g of celite were added sequentially. After a final 15 minutes of stirring the reaction mixture was filtered through a pad of Celite and evaporated. High boiling TBHP in toluene was removed azeotropically by rotary evaporator by adding a large amount of ethyl acetate to give 6.1 g of a syrupy oil. Purification by flash chromatography using 5:1 hexane: ethyl acetate as the solvent

system provided 4.3 g (77%, 94.9% ee by optical rotation and 93% ee from chiral shift studies) of a low melting solid. mp 51°C;  $[\alpha]_{\text{D}}^{25}$  -47.08 (c 2.4, CHCl<sub>3</sub>) {lit<sup>2</sup>  $[\alpha]_{\text{D}}^{25}$  -49.6 (c 2.4, CHCl<sub>3</sub>)}

<sup>1</sup>H NMR (CDCl<sub>3</sub>) δ 7.2(m, 5H), 4.08(ddd, 1H, J=12.8, 2.4, 5 Hz), 3.90(d,1H, J=2.05 Hz), 3.77(ddd, 1H, J=12.8, 7.7, 3.8 Hz), 3.2(m,1H), 2.1(br,1H); ei-MS m/z 150 (M<sup>+</sup>, 5.5%), 107(M<sup>+</sup>-43, 40%), 91(M<sup>+</sup>-109, 100%).

(2S-trans)-3-(2-naphthyl)oxiranemethanol 44b

The epoxidation was performed as described for the preparation of 44a, using 165 mL of CH<sub>2</sub>Cl<sub>2</sub>, 1 g of powdered, activated 4A molecular sieves, 0.464 g (1.63 mmol, 10 mol%) of titanium isopropoxide, 0.204 g (1.95 mmol, 12 mol%) of L (+) diisopropyl tartarate, 9.31 mL of a 3.5 M solution of TBIIP in toluene and (E) -3-naphthyl-2-propenol (16.3 mmol) at -20° C.

A similar workup, as described for 44a was followed: 3.4 mL of a 10% aqueous solution of sodium hydroxide saturated with sodium chloride solution, 3.4 g of magnesium sulfate, 0.18 g of celite and 20 mL of ether were used. After evaporating the solvent, 3.8 g of white solid was obtained. Purification by flash chromatography using 5:1 hexane: ethyl acetate, as an eluant gave 2.4 g (73%, 94% ee based on chiral shift studies of the corresponding acetate) of a white powdery solid of mp. 143°C;  $[\alpha]_{\text{D}}^{25}$  -49.6 (c 0.75, CHCl<sub>3</sub>).

<sup>1</sup>H NMR (CDCl<sub>3</sub>) δ 7.2-7.8(m, 7H), 4.08 (m, 2H), 3.84(ddd, 1H, J=3.7, 7.9, 12 Hz), 3.31(ddd, 1H, J=3.7, 2.3, 2.3 Hz), 1.84(b, 1H); ei-MS m/z 200(M<sup>+</sup>, 20%), 150(M<sup>+</sup>-59, 100%).

(2S-trans)-3-(4-isopropylphenyl)oxiranemethanol 44c

The epoxidation reaction was carried out as described above using 165 mL of CH<sub>2</sub>Cl<sub>2</sub>, 1 g of powdered, activated 4A molecular sieves, 0.221 g (0.9 mmol, 6 mol%) of diisopropyl tartrate, 0.235 g (0.78 mmol, 5 mol%) of titanium isopropoxide, 9.02 mL of a 3.5 M solution of TBHP in toluene and (E)-3 (4-isopropylphenyl)-2-propenol. The reaction mixture was stirred over 10 h at -20° C.

A workup similar to 44a was followed. 1.7 mL of a 10% aqueous solution of sodium hydroxide saturated with sodium chloride solution, 1.7 g of magnesium sulfate, 0.17 g of celite and 20 mL of ether were used. After evaporating the solvent 4.3 g of pure product was isolated which was purified by flash chromatography using 90% of 3:1 hexane and ethyl acetate and 10% CCl<sub>4</sub> to afford 1.85 g of a syrupy liquid [ $\alpha$ ]<sub>D</sub><sup>25</sup> -26.4 (c 3.0, CHCl<sub>3</sub>). (60% yield, 88.4% ee based on chiral shift studies) and 0.5 g of starting material. (71% yield on the basis of starting material consumption).

<sup>1</sup>H NMR (CDCl<sub>3</sub>)  $\delta$  7.17(d, 2H, J=8.1 Hz), 7.1(d, 2H, J= 8.1 Hz), 3.88(ddd, 1H, J=12.8, 4.7, 2.4 Hz), 3.8(d, 1H, J=2.2 Hz), 3.7(ddd, 1H, J=12.5, 7.4, 3.7 Hz), 3.2(ddd, 1H, J=3.8, 2.3, 2.3 Hz), 2.45(d, 2H, J=7.2 Hz), 1.8(m, 1H), 0.87(d, 6H, J=7 Hz); ir (neat) cm<sup>-1</sup> 3500 (br), 2940; ei-MS m/z 206 (M<sup>+</sup>, 3.9%), 147(M<sup>+</sup>-59, 88%), 105(M<sup>+</sup>-101, 100%).

**General preparation and shift study analysis of Acetates**

Epoxy alcohol (20 mg) was dissolved in 3 mL of pyridine and 3 mL of Ac<sub>2</sub>O. The reaction mixture was stirred for 4 h. It was then diluted with 10 mL of CH<sub>2</sub>Cl<sub>2</sub> and extracted three times with 5 mL of

a 10% phosphoric acid solution. The organic layer was dried over  $\text{MgSO}_4$  and evaporated.

Acetate (5 mg) was dissolved in an NMR tube with  $\text{CDCl}_3$  dried over molecular sieves. After recording the regular  $^1\text{H}$  NMR, 2 or 3 drops of  $\text{Eu}(\text{hfc})_3$  solution, prepared by dissolving 5 mg of  $\text{Eu}(\text{hfc})_3$  in 1 mL of  $\text{CDCl}_3$ , was added. The singlet for the  $\text{CH}_3$  group of the acetate was split into two lines. The enantiomeric excess was determined by measuring the integration of the two lines.

#### Compound 51a (reaction of 44a with py/ $\text{Ac}_2\text{O}$ )

The general procedure described above for the shift analysis of acetate was followed and then subjected to  $\text{Eu}(\text{hfc})_3$  shift studies to determine ee. The acetate 51a showed the following NMR peaks.

$^1\text{H}$  NMR ( $\text{CDCl}_3$ )  $\delta$  7.30(m, 5H), 4.46(q, 1H,  $J=5.9, 12.3$  Hz), 4.08(q, 1H,  $J=5.9, 12.3$  Hz), 3.79(d, 1H,  $J=2.1$  Hz), 3.25(ddd, 1H,  $J=2.1, 5.9, 3.3$  Hz), 2.1(s, 3H).

#### Compound 51b (reaction of 44b with py/ $\text{Ac}_2\text{O}$ )

The general procedure described above for the shift analysis of acetate was followed and then subjected to  $\text{Eu}(\text{hfc})_3$  shift studies to determine ee. The acetate 51b showed the following NMR peaks.

$^1\text{H}$  NMR ( $\text{CDCl}_3$ )  $\delta$  7.8(m, 4H), 7.48(m, 2H), 7.3(dd, 1H,  $J=8.6, 1.7$ ), 4.51(dd, 1H,  $J=12.2, 3.3$  Hz) 4.13(dd, 1H,  $J=5.8, 12.2$  Hz), 3.96(d, 1H,  $J=2.0$  Hz), 3.36(ddd, 1H,  $J=2, 5.8, 3.3$  Hz), 2.12(s, 3H).

Compound 51c (reaction of 44c with py/ Ac<sub>2</sub>O)

The general procedure described above for the shift analysis of acetate was followed and then subjected to Eu(hfc)<sub>3</sub> shift studies to determine ee. The acetate 51c showed the following NMR peaks.

<sup>1</sup>H NMR (CDCl<sub>3</sub>) δ 7.15(d, 2H, J=8.3 Hz), 7.10(d, 2H, J=8.3 Hz), 4.45(dd, 1H, J=3.3, 12.2 Hz) 4.06(dd, 1H, J=6.0, 12.2 Hz), 3.76(d, 1H, J=2.0 Hz), 3.26(dd, 1H, J=3.3, 2.6 Hz), 2.45(d, 2H, J=7 Hz), 2.10(s, 3H), 1.8(m, 1H), 0.87(d, 6H, J=6.6 Hz).

Compound 45a (reaction of 44a with trimethylaluminium)

A solution of epoxy alcohol 44a (0.75 g, 5 mmol) in 10 mL of CH<sub>2</sub>Cl<sub>2</sub> was added dropwise to a stirred solution of 3.8 mL of 2M trimethylaluminium in hexane at 0° C under nitrogen atmosphere. The stirring was continued for 3 h at room temperature. The reaction mixture was quenched with dilute HCl. The organic layer was washed with saturated NaCl solution, dried over MgSO<sub>4</sub> and evaporated to give 0.8 g of an oil. The crude product was purified by Chromatotron to give 80 mg (9.6%) of 46a and 506 mg (60%) of 45a, an oil. [α]<sub>D</sub><sup>25</sup> +3.85 (c 2.0, CHCl<sub>3</sub>).

45a: <sup>1</sup>H NMR (CDCl<sub>3</sub>) δ 7.26(m, 5H), 3.71(m, 1H), 3.3(m, 2H), 2.762(q, 1H, J=7 Hz), 1.31(d, 3H, J=7 Hz); IR (neat) cm<sup>-1</sup> 3500, 2990, 1610, 1500; ei-MS m/z 135(M<sup>+</sup>-31, 11%), 106(M<sup>+</sup>-60, 100%), 91(M<sup>+</sup>-75, 58%).

Compound 45b (reaction of 44b with trimethylaluminium)

To a solution of 44b (1 g, 5 mmol) epoxide in 15 mL of CH<sub>2</sub>Cl<sub>2</sub> at 0° C, under nitrogen atmosphere, 3.75 mL of 2M

trimethylaluminium in hexane was added dropwise. The reaction mixture was stirred at 0° C for 3 h and then quenched with dilute HCl. After extractive workup was carried out as described in 45a, the crude material (1.22 g) was purified by chromatotron using 95% CH<sub>2</sub>Cl<sub>2</sub>: hexane (6:1), 4% of EtOAc and 1% of MeOH as a solvent system. The yield of 38b was 30 mg (2%) and of 45b was 770 mg, an oil, (71%).  $[\alpha]_D^{25} +7.0$  (c 1.8, CHCl<sub>3</sub>).

45b: <sup>1</sup>H NMR (CDCl<sub>3</sub>) δ 7.25(m,7H), 3.75(ddd,1H, J=7.8, 7.69, 3.14), 3.463(ddd, 1H, J=11.1, 3.12 Hz), 3.34(dd,1H, J=11.1, 7.5 Hz), 2.79(q, 1H, J= 7 Hz), 1.840(d, 3H, J=7 Hz); IR (CHCl<sub>3</sub>) cm<sup>-1</sup> 3,500-3300(br), 3050, 2950; ei-MS m/e 216(M<sup>+</sup>, 24), 155(M<sup>+</sup>-61, 100%), 142(M<sup>+</sup>-54, 23.7).

Compound 45c (reaction of 44c with trimethylaluminium)

To a solution of 44c (1 g, 4.85 mmol) epoxide in 15 mL of CH<sub>2</sub>Cl<sub>2</sub> at 0° C, under nitrogen atmosphere, 3.64 mL of 2M trimethylaluminium in hexane was added dropwise. The reaction mixture was stirred at 0° C for 2 h and then quenched with dilute HCl. After extractive workup was carried out as described in 45a, the crude material (1.25 g) was purified by chromatotron using 95% CH<sub>2</sub>Cl<sub>2</sub>: hexane (6:1), 4% of EtOAc and 1% of MeOH as a solvent system. The yield of 45c was 630 mg, an oil, (59%).  $[\alpha]_D^{25} -0.9$  (c 2.2, CHCl<sub>3</sub>).

45c: <sup>1</sup>H NMR (CDCl<sub>3</sub>) δ 7.06(s,4H), 3.73(m,1H), 3.43(m, 1H), 2.76(quin,1H, J=7.0 Hz), 2.42(d, 2H, J= 7 Hz), 1.840(m, 1H); IR (CHCl<sub>3</sub>) cm<sup>-1</sup> 3,500-3300(br); ei-MS m/e 155(M<sup>+</sup>-61, 100%), 119(M<sup>+</sup>-103, 53.2).

2-Phenylpropanoic acid (47a)Method (a)

To a suspension of 37(a) (480mg, 2.89 mmol) in a mixture of CH<sub>3</sub>CN/CCl<sub>4</sub>/H<sub>2</sub>O (2:2:3, v/v, 21mL) at room temperature, was added 17 mg of ruthenium (III) chloride (17 mg ) and 2.85 g periodic acid. The mixture was stirred for 2 h. The reaction mixture was diluted with ether and extracted with 5% aqueous NaHCO<sub>3</sub> solution (3X10 mL). The aqueous extracts were acidified with conc. HCl and extracted with ethyl acetate (3X15 mL), dried and evaporated to give 300 mg (70%) of oil.  $[\alpha]^{25}_D +72.9$  (c 3.108, EtOH); 90% ee (based on  $[\alpha]^{20}_D +81.1$  reported for the pure (S) enantiomer<sup>13</sup>). The NMR spectrum of this material was identical to that obtained by method (b) below.

Method (b)

To a solution of diol 45a (498mg, 3 mmol) in t-BuOH was added a solution of NaIO<sub>4</sub> (706mg, 3.3 mmole) in 4.5 mL of water at room temperature. After 10 minutes, 1.25 M sodium phosphate buffer solution (12 mL) and a solution of potassium permanganate (1 M, 6.0 mL) were added sequentially. After 15 minutes the reaction mixture was quenched with saturated Na<sub>2</sub>SO<sub>3</sub> solution (4.5 mL). Colloidal MnO<sub>2</sub> was formed. Dilute HCl was added to dissolve the MnO<sub>2</sub> and the aqueous layer was extracted several times with ethyl acetate. The organic layer was dried with MgSO<sub>4</sub> and evaporated under reduced pressure to give a residue (560 mg). The residue was dissolved in ether and the organic layer was extracted with saturated Na<sub>2</sub>SO<sub>3</sub> solution (1X10 mL) followed by 5% aqueous NaHCO<sub>3</sub> solution

(2X10 mL). The basic extracts were acidified and extracted with (3X15 mL) of ethyl acetate, dried with  $MgSO_4$  and evaporated to yield 350 mg (77%) of oil.  $[\alpha]_D^{25} +71.9$  (c 3.108, EtOH); 89% ee (based on  $[\alpha]_D^{20} +81.1$  reported for the (S) enantiomer<sup>13</sup>).

$^1H$  NMR ( $CDCl_3$ )  $\delta$  7.3(s, 5H), 3.71(q, 1H, J=7 Hz), 1.49(d, 3H, J=7 Hz); IR (neat)  $cm^{-1}$  3500-2500 (br), 1710; ei-MS m/e 150( $M^+$ , 25%), 105( $M^+-45$ , 100%); HR-MS calcd 200.0837, found 200.0848.

#### 2-(2-naphthyl)propanoic acid 47b

We failed to isolate 2-(2-naphthyl)propanoic acid by following method (a).

The synthesis of 47a, via oxidative cleavage reaction was performed on 45b following method(b) above. The reaction was carried out in 10 mL of t-BuOH and 3 mL of water with 432 mg (2 mmol) of diol 45b, 8 mL of 1.25 M phosphate buffer, 470 mg (2.8 mmol) of periodate and 4 mL of 1M  $KMnO_4$  solution. After the extractive workup, 245 mg (62%, 97% ee by chiral shift studies and >98% ee by optical rotation) of white solid of mp 139°C was isolated  $[\alpha]_D^{25} +67.44$  (c 2.5,  $CHCl_3$ ).

$^1H$  NMR ( $CDCl_3$ )  $\delta$  7.77(m, 4H), 7.4(m, 3H), 3.39(q, 1H J=7); 1.59(d, 3H, J=7); ir ( $CHCl_3$ )  $cm^{-1}$  3500-2400 (br), 1720; ei-ms m/e 200( $M^+$ , 43.8%), 155( $M^+$ , -45, 100); HR-MS calcd 200.0837, found 200.0848.

#### Ibuprofen 47c

The oxidative cleavage reaction, method(b), described for 47a was performed, in this case using 222 mg (1 mmol) of diol 45c, 4 mL of 1.25 M phosphate buffer, 235 mg (1.4 mmol) of periodate and 2

ml. of 1 M  $\text{KMnO}_4$  solution in 5 mL *t*-BuOH and 1.5 mL of water. The reaction provided 55 mg of acid, a thick oil (26.6%).

The use of method (a), on 100 mg of diol afforded 43 mg of acid as a thick oil (46.5%).  $[\alpha]^{25}_{\text{D}} +39.91$  (c 4.9,  $\text{CHCl}_3$ ); 81% ee (based on  $[\alpha]^{25}_{\text{D}} +46.9$  reported for the (S) enantiomer<sup>26</sup>).

$^1\text{H}$  NMR ( $\text{CDCl}_3$ )  $\delta$  7.2(d, 2H,  $J=8$  Hz), 7.08(d, 2H,  $J=8$  Hz), 3.69(q, 1H,  $J=7$  Hz), 1.81(h, 1H,  $J=7$  Hz), 1.48(d, 3H,  $J=7$  Hz), 0.87(d, 6H,  $J=7$  Hz); IR (neat)  $\text{cm}^{-1}$  3500-2500 (br), 1710; ei-MS  $m/e$  206( $\text{M}^+$ , 43%), 163( $\text{M}^+-43$ , 100%), 165( $\text{M}^+-45$ , 98%); HR-MS  $\text{M}^+$  calcd 206.1307, found 206.1311.

#### General preparation and shift study analysis of esters

The 2-aryl propionic acid (30 mg) was dissolved in diethyl ether. It was stirred at room temperature and diazo methane in ether was added dropwise until the yellow colour persisted. The solution was evaporated and passed through a silica plug to remove any base line impurities.

Methyl ester (5 mg) was dissolved in  $\text{CDCl}_3$  dried over molecular sieves and placed in an NMR tube. Addition of a small amount of  $\text{Eu}(\text{hfc})_3$  solution caused the doublet for the methyl group present on the  $\alpha$  carbon to the ester to divide into four peaks. The enantiomeric excess of the material was determined by integration of the various peaks.

Reaction of 47a with CH<sub>2</sub>N<sub>2</sub>

The general procedure described above for the shift analysis of ester was followed and then subjected to Eu(hfc)<sub>3</sub> shift studies to determine ee. The ester showed the following NMR peaks.

<sup>1</sup>H NMR (CDCl<sub>3</sub>) δ 7.28(m, 5H), 3.70(q, 1H, J=7.0 Hz), 3.64(s, 3H), 1.48(d, 3H, J=7.1 Hz)

Reaction of 47b with CH<sub>2</sub>N<sub>2</sub>

The general procedure described above for the shift analysis of ester was followed and then subjected to Eu(hfc)<sub>3</sub> shift studies to determine ee. The ester showed the following NMR peaks.

<sup>1</sup>H NMR (CDCl<sub>3</sub>) δ 7.77(m, 3H), 7.70(s, 1H), 7.50(m, 3H), 3.87(q, 1H, J=7.0 Hz), 3.62(s, 3H), 1.58(d, 3H, J=7.1 Hz).

Reaction of 47c with CH<sub>2</sub>N<sub>2</sub>

The general procedure described above for the shift analysis of ester was followed and then subjected to Eu(hfc)<sub>3</sub> shift studies to determine ee. The ester showed the following NMR peaks.

<sup>1</sup>H NMR (CDCl<sub>3</sub>) δ 7.16(d, 2H, J=1.8 Hz), 7.08(d, 2H, J=1.8 Hz), 3.67(q, 1H, J=7.2 Hz), 3.64(s, 3H), 2.42(d, 2H, J=7.2 Hz), 1.83(m, 1H), 1.46(d, 3H, J=7.2 Hz), 0.88(d, 6H, J=6.6 Hz).

## References

1. Chemical and Engineering News, 26, March 19, 1990.
2. Y. Gao, R.M. Hanson, J.M. Klunder, S.Y. Ko, H. Masamune, B.K. Sharpless, *J. Amer. Chem. Soc.*, 1987, 109, 5765.
3. D.L. Boger, D. Yohannes, *J. Org. Chem.*, 1989, 54, 2498.
4. For review see M.J. Jung, In *Chemistry and Biochemistry of amino acids*, G.C. Barrett, Ed.: Chapman and Hall: New York, 1985, 227.
5. J. Walsh, D.E. Metzler, *J. Amer. Chem. Soc.*, 1980, 102, 7136.
6. D.A. Evans, J.A. Ellman, R.L. Dorrow, *Tetrahedron Letts.*, 1987, 28, 1123.
7. W. Oppolzer, R. Pedrosa, R. Moretti, *Tetrahedron Letts.*, 1986, 27, 831.
8. R.M. Williams, P. Sinclair, D. Zhai, D. Chen, *J. Amer. Chem. Soc.*, 1988, 110, 1547.
9. B.E. Rossiter, In *Asymmetric Synthesis*, J.D. Morrison, Ed: Academic Press, New York., Vol. 5, 1985, Chap.7, 193.
10. A. Pffininger, *Synthesis*, 1986, 89.
11. M. Caron, K.B. Sharpless, *J. Org. Chem.*, 1985, 50, 1560.
12. M. Caron, P.R. Carlier, B.K. Sharpless, *J. Org. Chem.*, 1988, 58, 5187.
13. J.P. Rieu, A. Boucherle, H. Cousse, G. Mouzin, *Tetrahedron*, 1986, 42, 4095.
14. W.D. Lubell, H. Rapoport, *J. Amer. Chem. Soc.*, 1988, 110, 7447.
15. G. Parrinello, J. K. Stille, *J. Amer. Chem. Soc.*, 1987, 109, 7122.

16. K. Fuji, M. Node, F. Tanaka, S. Hosoi, *Tetrahedron Letts.*, 1989, 30, 2825.
17. T. Ohta, H. Takay, M. Kitamura, K. Nagai, R. Noyori, *J. Org. Chem.*, 1989, 52, 5734.
18. R.D. Larsen, E.G. Corley, P. Davis, P.J. Reider, E.J.J. Grabowski, *J. Amer. Chem. Soc.*, 1989, 111, 7650.
19. (a) W.R. Roush, M.A. Adam, S.M. Peseckis, *Tetrahedron Letts.*, 1983, 24, 1377; (b) T. Suzuki, H. Saimoto, H. Tomioka, K. Oshima, H. Nozaki, *Tetrahedron Letts.*, 1987, 23, 3597.
20. (a) P.J. Carlsen, T. Katasuki, V.S. Martin, K.B. Sharpless, *J. Org. Chem.*, 1986, 46, 3396; (b) M. Caron, P.R. Carlier, K.B. Sharpless, *J. Org. Chem.*, 1988, 53, 5185.
21. (a) M. Respondek, A. Lieberknecht, J. Werner, U. Schlmidt, *Synthesis*, 1989, 256; (b) A. Abiko, J.C. Robert, T. Takemasa, S. Masamune, *Tetrahedron Letts.*, 1986, 27, 4537.
22. J. Buckingham, S.M. Donaghy, Eds. *Dictionary of Organic Compounds*; Chapman and Hall New York, Vol 5, 4662.
23. Nathalie Hamel, Ph.D thesis, 1989, p 93, University of Ottawa.

## CHAPTER 2

### Synthesis and reactivity of thiophene xylylene

#### Introduction

Orthoquinodimethane, a special class of diene, has been used extensively to synthesize natural products containing a six membered ring fused to an aromatic ring. Orthoquinodimethane is also known as o-xylylene or o-quinodimethide in the literature. It is a very reactive species which cannot be isolated and thus is generated and used *in situ*. It undergoes facile Diels-Alder reactions, (4+2 cycloadditions) in the presence of a dienophile. The molecule gains aromaticity during this process. In an intermolecular Diels-Alder reaction these dienes tend to give a mixture of regioisomers and stereoisomers. One can circumvent the problem of regiochemistry by using an intramolecular Diels-Alder reaction where the orthoquinodimethane and the dienophile are attached. (Scheme 1) Another advantage of this approach is that in a single reaction one can often predictably create four contiguous chiral centres. Some of the approaches of generating o-quinodimethane are illustrated below.

Scheme 1

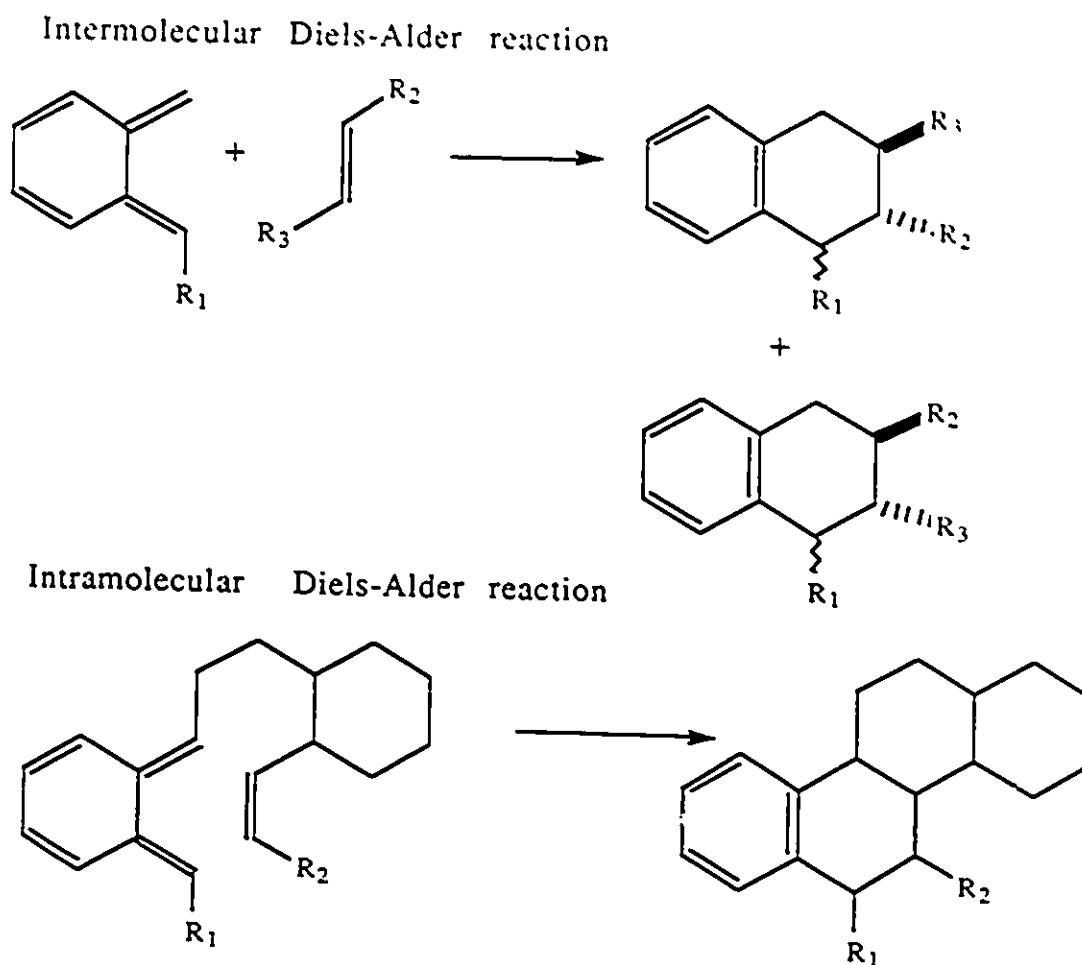

Generation and synthetic utility of o-quinodimethanes

The classical and most important approach to o-quinodimethanes is the cheletropic extrusion of sulfur dioxide from 1,3-dihydrobenzothiophene 2,2-dioxides such as 2. Cava was a pioneer in this area of chemistry. He synthesized the precursor cyclic

sulfones from 1,2-dichloromethylbenzene, **1**, (Scheme 2). On thermolysis at  $>250^{\circ}\text{C}$  the sulfone **2** generated orthoquinodimethane, **3**, which underwent an intermolecular Diels-Alder reaction with naphthoquinone to afford the tetracyclic derivative **4**.<sup>1</sup> Other applications of the  $\text{SO}_2$  extrusion route have been described. These include the synthesis of steroids<sup>2,3</sup> (Oppolzer, Nicolaou) and lignans<sup>4,5</sup> (Mann, Charlton). These approaches have recently been reviewed by Charlton.<sup>6</sup>

Scheme 2

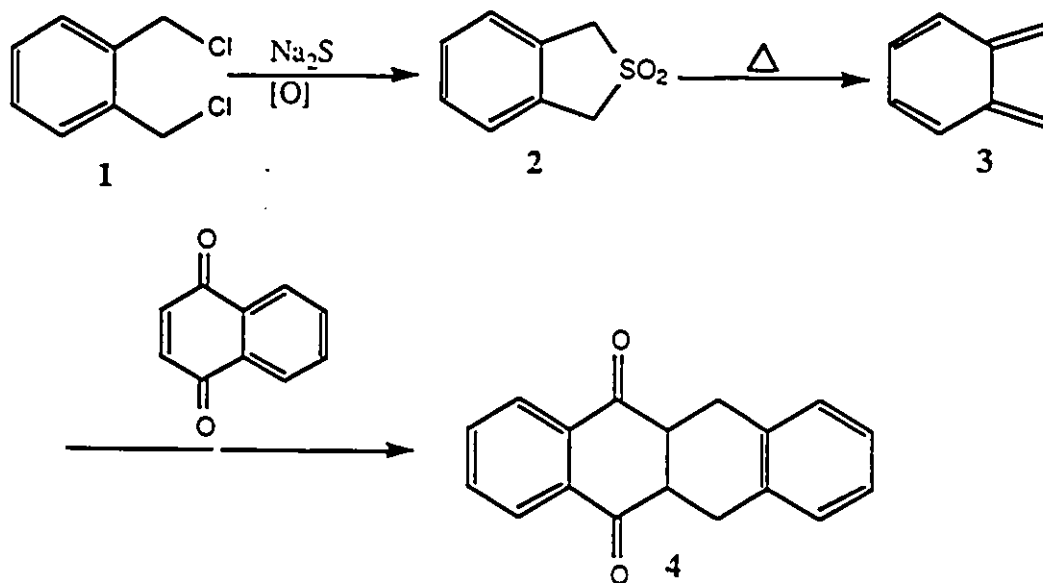

Oppolzer first demonstrated the synthetic utility of generating o-quinodimethanes via ring opening of benzocyclobutanes and trapping these transient species by an intramolecular Diels-Alder reaction.<sup>7</sup>

Scheme 3

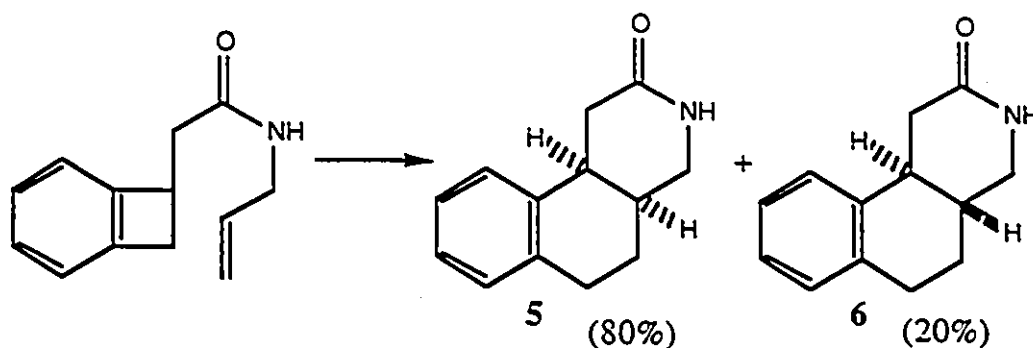

Kametani and his group recognized the tremendous potential of this approach and published numerous examples including the application to steroid synthesis shown below.<sup>8</sup> (Scheme 4) In this sequence the key benzocyclobutene **8** was prepared by trapping of a benzyne obtained by treating **7** with excess  $\text{NaNH}_2$ . Compound **10** was assembled by treatment of 2-cyclohexenone with divinylcuprate followed by trapping with iodide **9**. Finally, thermolysis of **10** at about  $200^\circ\text{C}$  gave the homosteroid **11**. It is obvious from reading the various Kametani papers that the benzocyclobutene approach to o-quinodimethane is often rather lengthy; for example, the iodide **9** required 9 steps from commercially available 3-methoxybenzaldehyde.

McDonald and Durst have also utilized the benzocyclobutene ring opening approach in the synthesis of podophyllotoxin.<sup>9</sup>

Scheme 4

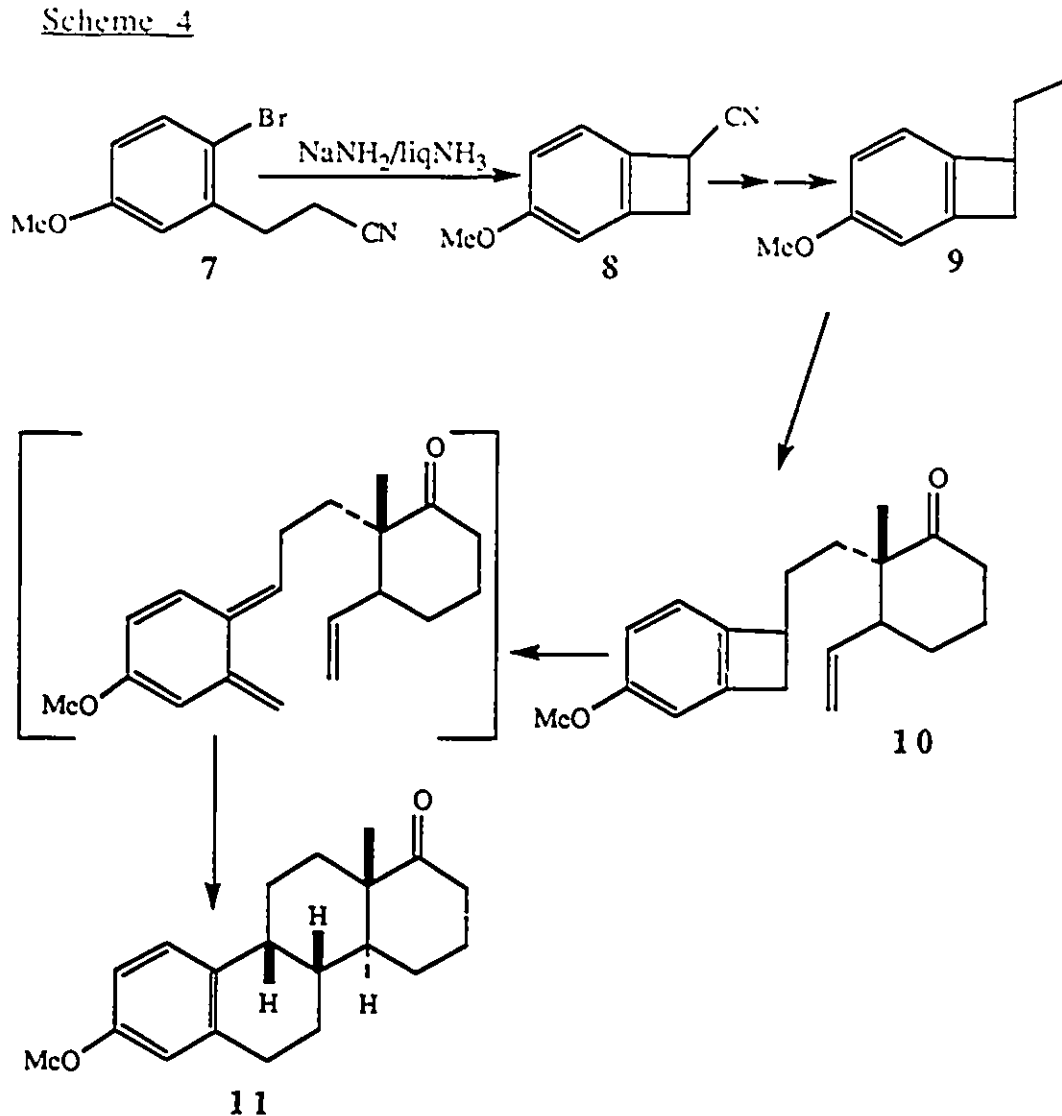

Saegusa generated orthoquinodimethanes by a 1,4 elimination from silylammonium salts<sup>10</sup> such as **12** using fluoride anion at room temperature to initiate the fragmentation process. When such a fragmentation was carried out in the presence of a dienophile the expected Diels-Alder adducts were obtained in good yields.<sup>11</sup> Using this methodology they were able to generate o-quinodimethanes

bearing a chiral auxiliary, **12**. Trapping of **13** afforded, regioselectively and stereospecifically via an endo transition state, 1,2-disubstituted tetralins (Scheme 5). The enantiomeric excess of the product was 67%. The requisite oxazolidine was prepared from *o*-[(trimethylsilyl)methyl]benzaldehyde and ephedrine.<sup>12</sup>

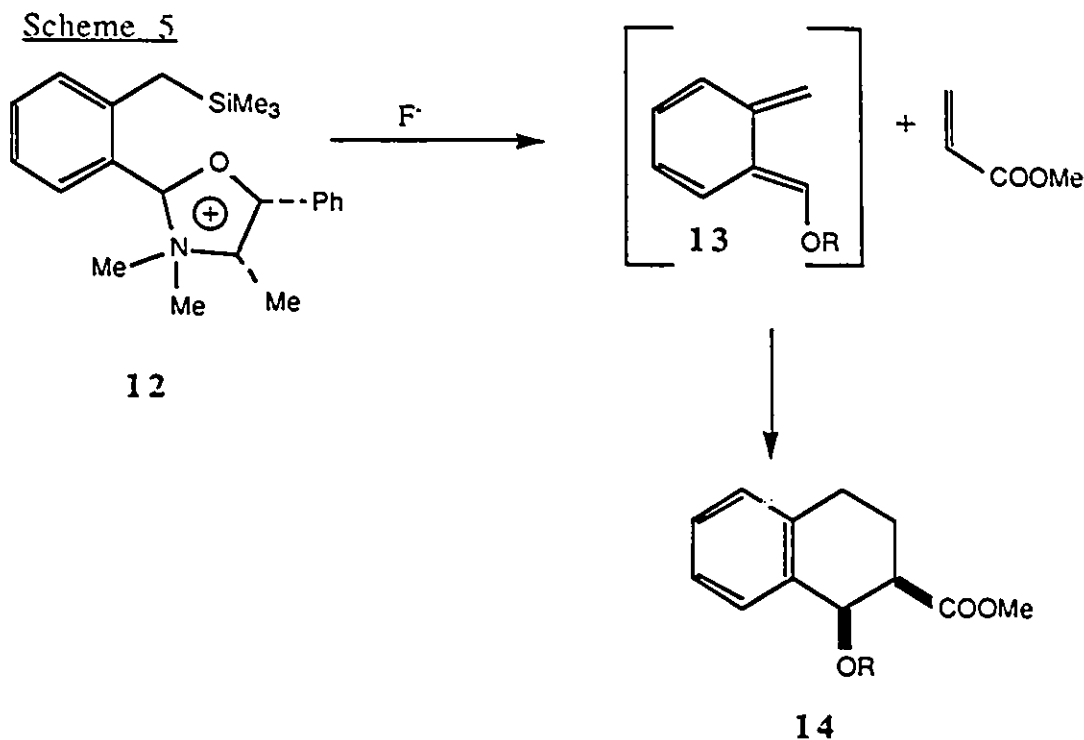

One could imagine that analogues of orthoquinodimethane involving heterocycles could be used to achieve a greater diversity in the synthesis of heterocyclic target molecules. The first example of this approach was reported in 1982 when Magnus et al utilized indole 2,3-xylylenes in the synthesis of aspidospermidine (Scheme 6).<sup>13</sup> They prepared the tetracyclic structure **18** in two steps from 3-formyl-2-methylindole, **15**. On condensation of **15** with 2-

(phenylthio) ethylamine an imine formed, **16**. Acylation of the latter followed by refluxing in chlorobenzene formed **18** which was converted into ( $\pm$ )aspidospermidine.

Scheme 6

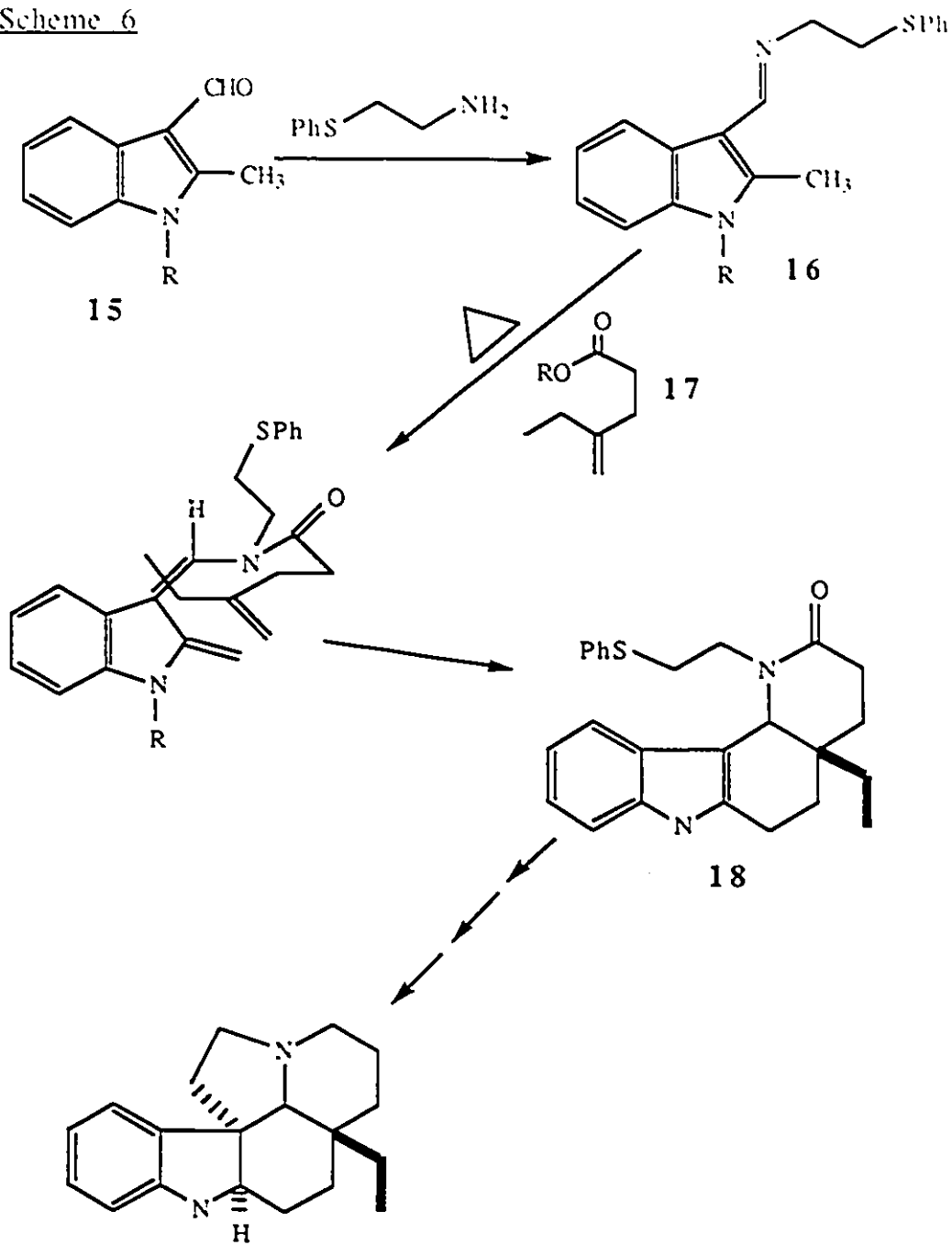

Aspidospermidine

Applications of other heterocyclic analogues of o-quinodimethane xylylenes had not been explored in organic synthesis at the beginning of this work. We envisaged that we could utilize thiophene xylylenes in the preparation of unnatural analogues of steroids as well as analogues of cancer-curing podophyllotoxin.

## Results and Discussion

Shortly after commencing our work towards the synthesis of thiophene xylylene, Mike Hrytsak in our labs made an important observation during his study of the synthesis of various oxacepham analogues via the well known intermolecular diazo insertion reactions catalyzed by rhodium acetate.

When an  $\alpha$ -diazo ketoester attached to a thiophene moiety, **20**, was used in the reaction, he obtained the desired product, **21**, in 17% yield. An unexpected product, **23**, was also isolated in 53% yield. One can explain the formation of **23** by a formal intramolecular insertion reaction of a rhodium carbenoid into a thiophene C-H bond.<sup>14</sup> (Scheme 7)

Scheme 7

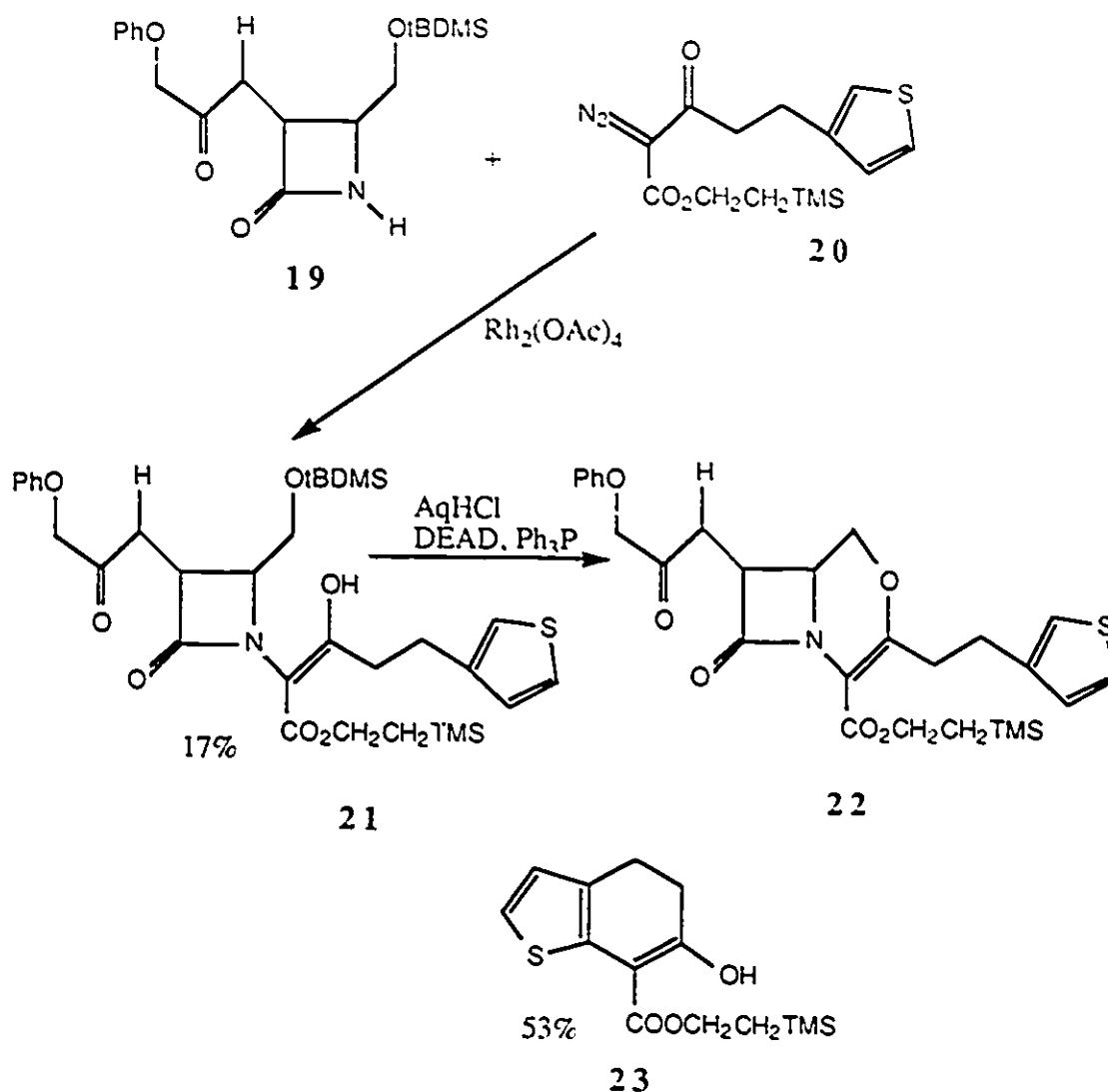

Several examples of intramolecular rhodium carbenoid insertion reactions into aliphatic C-H bonds had been reported in the literature. Wenkert disclosed the first report on the use of rhodium (II) acetate in the preparation of the D ring of the steroid skeleton in 1982.<sup>15</sup> (eqn-1)



structure 29, the desired precursor, 30, to thiophene xylylene should result.

The initial target in this project was the sulfone ester 30. This was prepared in four steps as shown Scheme 8. Thienyl bromide (3-bromomethylthiophene) was reacted with ethyl mercaptoacetate in the presence of potassium hydroxide to form the sulfide 27. The sulfide 27 was then oxidized to the sulfone 28 with 2 equivalents of meta-chloroperoxybenzoic acid in  $\text{CH}_2\text{Cl}_2$ . The sulfone was subjected to diazo transfer with tosyl azide/ NaH which furnished the diazo ester 29 in 45% yield. This diazo ester was stirred in  $\text{CH}_2\text{Cl}_2$  in the presence of 5 mole % of rhodium (II) acetate for 3 h. Filtration and evaporation of the solvent gave a yellow oil which was chromatographed on silica gel to give a 50% yield of insertion product 30 as light brown crystals, mp.  $92^\circ\text{C}$ . The structure of 30 was readily deduced from  $^1\text{H}$  NMR. A singlet for two protons at 4.36 ppm was assigned to the methylene protons  $\alpha$  to sulfone and a singlet at 5.16 ppm for one proton was assigned to the methine proton flanked by sulfone and ester groups. In addition two aromatic protons and 5 ester protons were identified. The success of the above reaction proved that an  $\alpha$ -sulfonyl carbenoid could undergo an aromatic insertion reaction.

Scheme 8

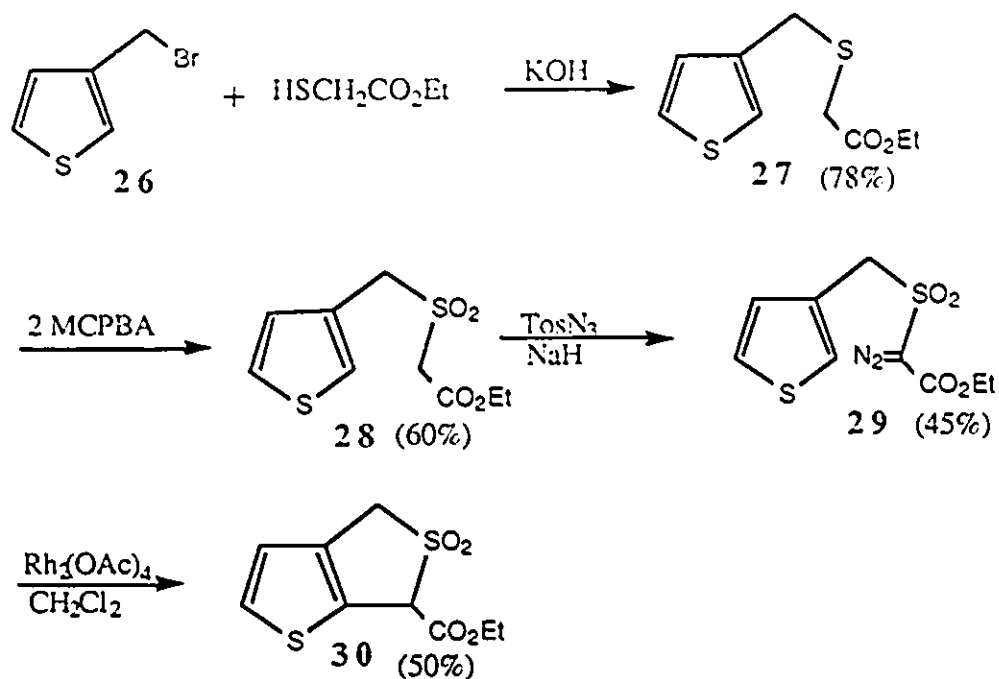

### Trapping Experiments

Thermolysis of the cyclic sulfone 30 in refluxing benzene, in the absence of dienophiles gave a single compound in 69% yield after purification by PTLC using 3:1 hexane:ethyl acetate as a solvent system. This material was identified as the dimer 32; no trace of the possible thiophenecyclobutene was observed. The  $^1\text{H}$  NMR and mass spectrum of 32 showed that a dimer had formed. The possible structures resulting from dimerization of the diene 31 are shown in Scheme 10. The  $^{13}\text{C}$  NMR of 32 displayed 4 methylene, 6 methine, and 2 methyl groups. This eliminated all but two of the possible

structures, namely 32 and 33. Examination of these two structures allows one to make the following predictions: For structure 32 one would expect a singlet for the proton adjacent to the saturated carbethoxy group in the 3.5 to 4.0 ppm region and a 4 proton multiplet which could conceivably appear as an AA'BB' pattern depending on the chemical shift differences between the hydrogens of the two adjacent methylene groups. In contrast, for 33 the hydrogen adjacent to the same carbethoxy group would appear as either a triplet or a quartet and one of the two methylenes should be either as a singlet or AB quartet and the other the AB part of an ABX pattern. The spectrum of the product showed a one proton singlet at 3.88 ppm and a series of multiplets centered at 3.0, 2.7, 2.5 and 1.8 ppm which were shown to couple to each other in its HOMCOR spectrum. These data confirm the structure to be 32.

Scheme 9

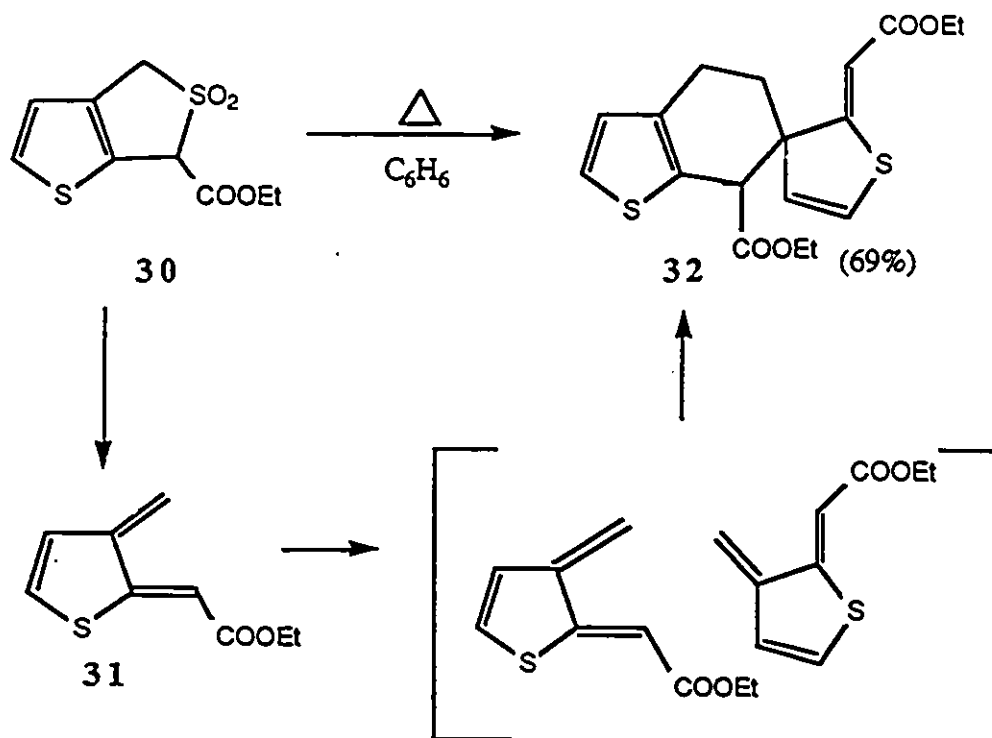

It is worthwhile noting that the temperature for SO<sub>2</sub> extrusion from the thiophene fused sulfones is at least 100°C less than from the corresponding 1,3-dihydrobenzothiophene-2,2-dioxides. For example, the latter compounds typically required thermolysis temperatures above 200°C unless strongly electron donating substituents such as OR, SR and NR<sub>2</sub> are present α to the sulfone group.<sup>17,18</sup> In the case of an α-aryl substituent SO<sub>2</sub> extrusion occurs at 210-220°C.<sup>4</sup> In contrast, all of the thiophene fused sulfone described in this thesis underwent thermolysis in refluxing benzene in less than 2 h. The ease of loss of SO<sub>2</sub> probably reflects the relative stabilities of the two diene systems.

Scheme 10

The other possible dimers are:

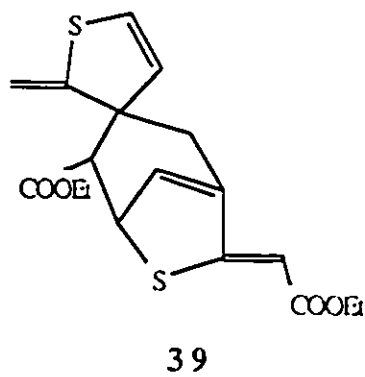
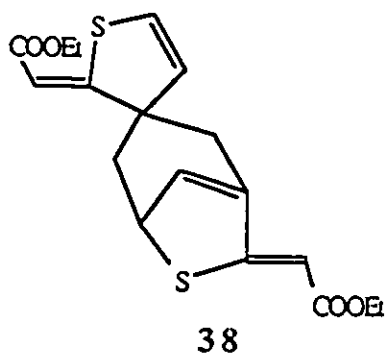
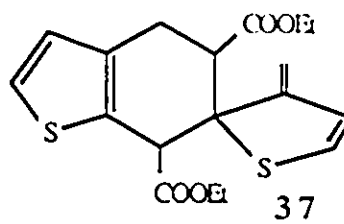
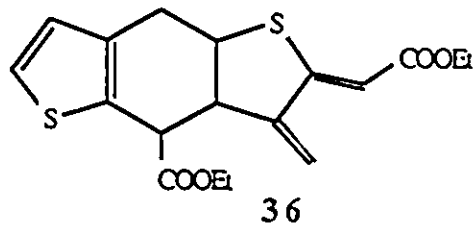
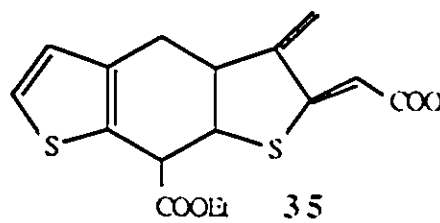
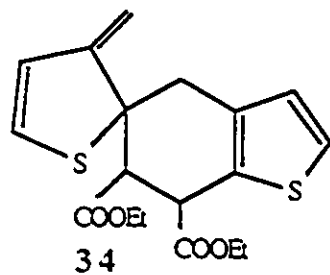
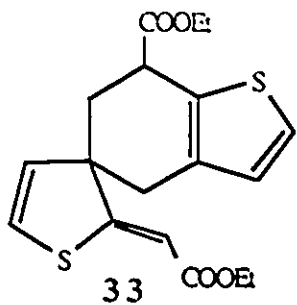

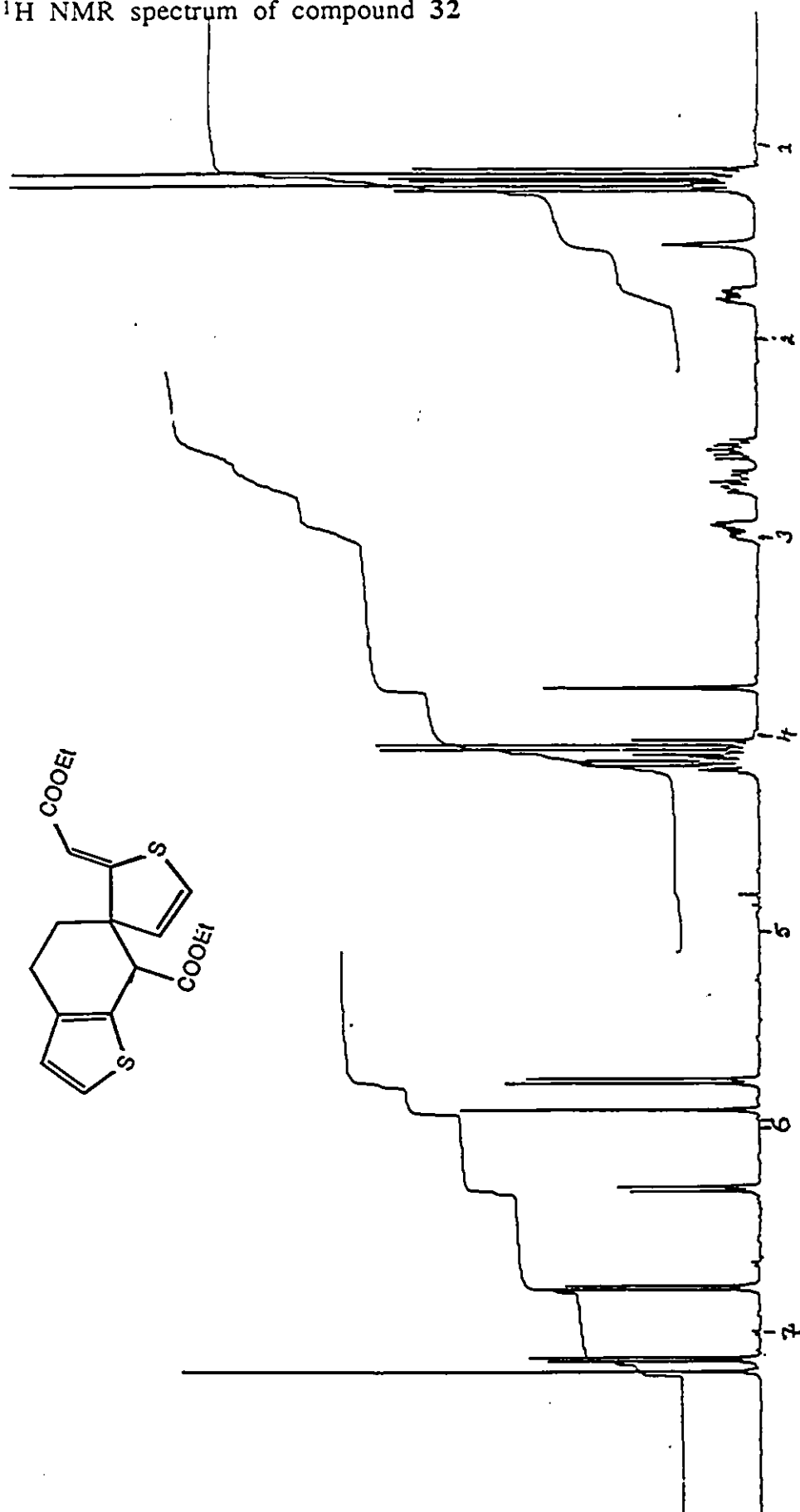
$^1\text{H}$  NMR spectrum of compound 32

When the thermolysis of **30** was carried out in the presence of various dienophiles such as dihydropyran, an electron rich dienophile or dimethyl acetylenedicarboxylate, an electron poor dienophile or norbornene, a generally reactive dienophile, no trace of cycloaddition products were observed and only the dimer **32** was isolated. Thus the carbethoxy substituted orthoquinodimethane analogue **31** of thiophene failed to undergo a 4+2 Diels-Alder reaction with typical reactive dienophiles. (Scheme 11)

Scheme 11

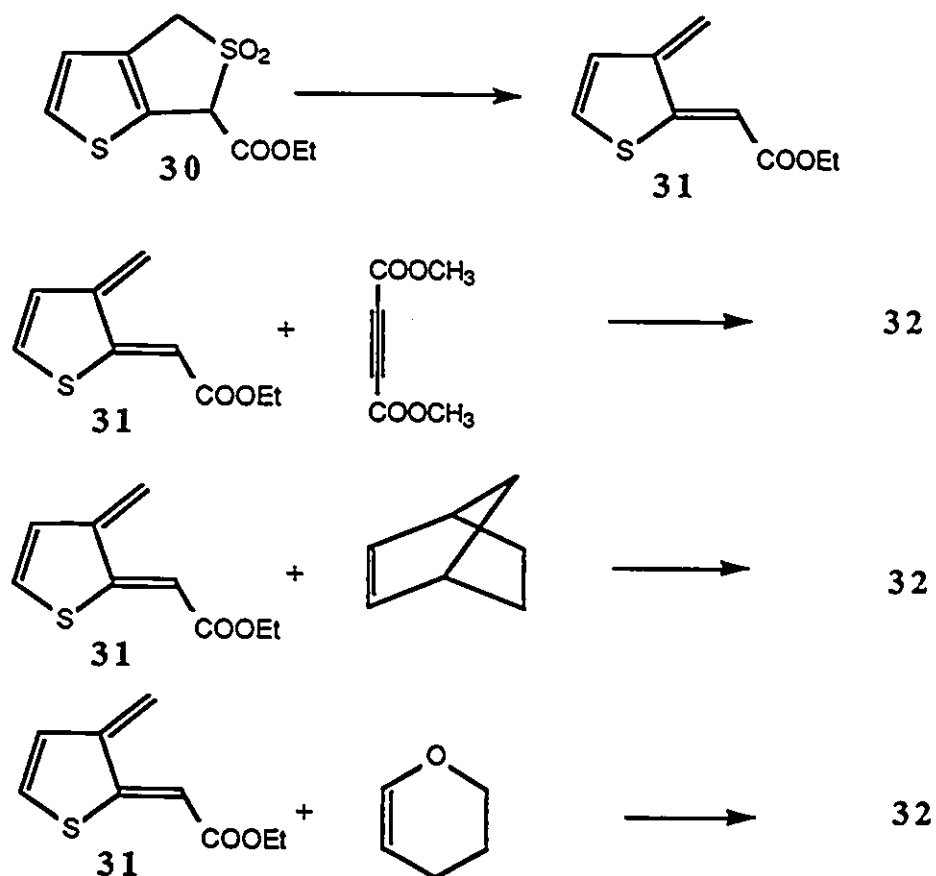

The thiophene sulfone **30** presents interesting possibilities for introduction of substituents via  $\alpha$ -sulfonyl carbanion chemistry. It is

well known that the alkylation of sulfones tends to produce mixtures of mono- and disubstituted products.<sup>3</sup> (eqn-3) In the case of the unsymmetrically substituted dihydrothiophene sulfone **43**  $\alpha$ -alkylation will tend to give a mixture of monosubstituted regioisomers and disubstituted products. (eqn-4). The production of isomers in this process lowers the value of sulfones such as **43** for the regiospecific generation of substituted o-quinodimethanes. (Scheme 12)

Scheme 12

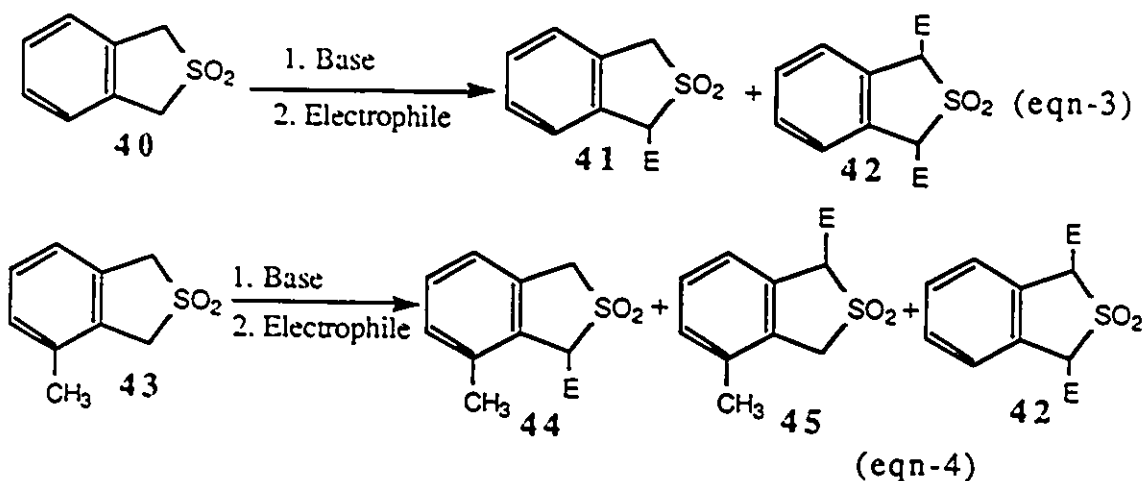

$\alpha$ -Sulfonyl carbanion chemistry coupled with the directing effect of the ester group as in **30** can be utilized to control the regiochemistry of the introduction of electrophilic substituents. In principle the use of one equivalent of base followed by addition of one equivalent of electrophile will result in monosubstitution at the most acidic centre. Addition of a second equivalent of base generates a 1,3-dianion. Alkylation should occur preferentially at the most reactive carbanion centre and yield a different regioisomer.

The validity of these postulates was examined by conducting three experiments:

- (i) Treatment of sulfone with one equivalent of base followed by one equivalent of electrophile. (eqn-5)
- (ii) Treatment of sulfone with two equivalents of base followed by addition of one equivalent of electrophile. (eqn-6)
- (iii) Treatment of sulfone with three equivalents of base followed by addition of two equivalents of electrophile. (eqn-7)

Scheme 13

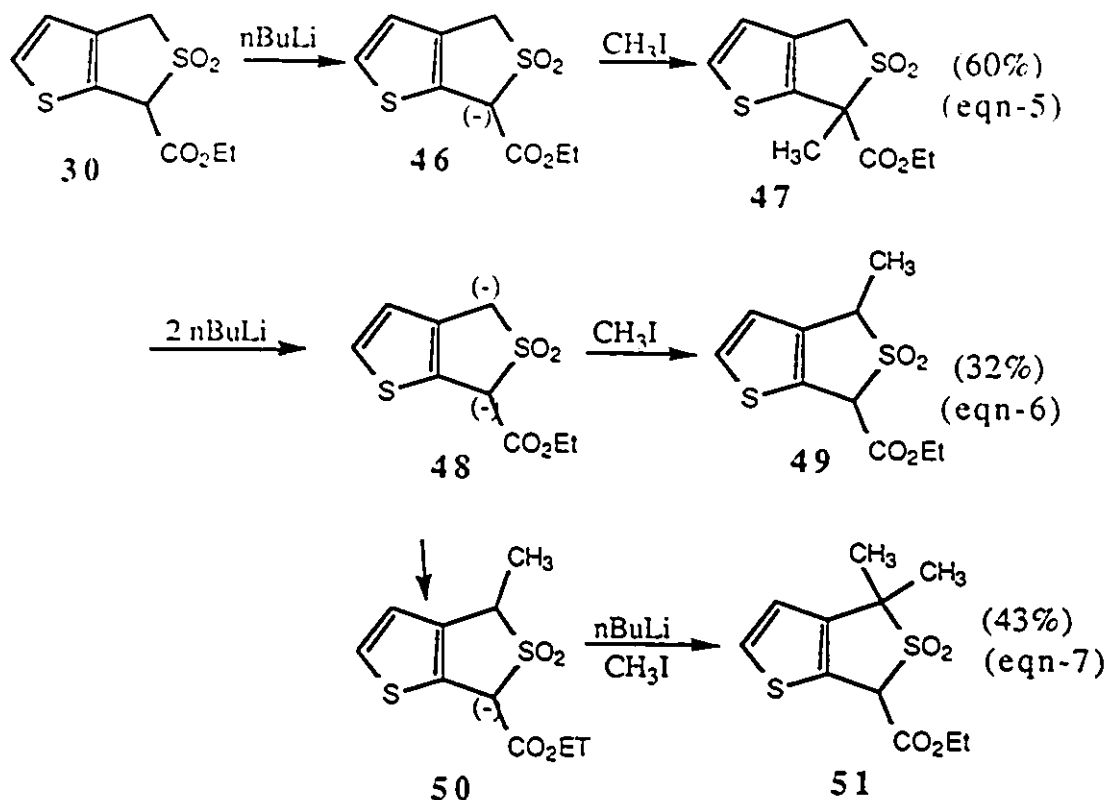

The intermediate monoanion **46** and the dianion **48** were generated by reaction with  $n\text{-BuLi}$  in THF at  $-78^\circ\text{C}$ . Reaction of **46** with excess methyl iodide afforded a 60% yield of **47**, while treatment of **48** with one equivalent of alkylating reagent gave a 2:1 mixture of cis and trans isomers of **49** in 32% isolated yield. The structures of these products were readily established by NMR spectroscopy. For example, **47** showed singlets for both the newly introduced methyl and the remaining methylene group  $\alpha$  to the sulfone at  $\delta$  1.90 and 4.33 ppm, respectively while **49** showed two methyl doublets near  $\delta$  = 1.66 ppm, and two methine singlets at  $\delta$  5.14 and 5.17 ppm due to the presence of cis and trans isomers. The

remaining methine hydrogen in 49 overlapped with the methylene group of the ester.

Finally, the reaction of 30 with 3 equivalents of n-BuLi followed by addition of 2 equivalents of MeI afforded the  $\alpha,\alpha$ -disubstituted product 51 in 43% yield. The mass spectrum (CI) showed a small molecular ion peak at the  $m/e=274+1$ , with the base peak at  $M-64$  due to the facile extrusion of  $\text{SO}_2$ . The NMR spectrum of 51 (60 MHz) featured, in addition to the ethyl group, a 6 proton singlet, ( $\delta=1.67$ , 2  $\text{CH}_3$ ), a 1 proton singlet ( $\delta=5.05$ ,  $\text{CH-SO}_2$ ), and two doublets at  $\delta$  6.88 and 7.43 ppm (due to the remaining thiophene hydrogens). The formation of 51 presumably involves rapid initial monomethylation of 48 to give 50, which then, with the third equivalent of nBuLi, forms a second dianion, which is then methylated at the more reactive  $\alpha'$  centre.

These results proved that the ester group  $\alpha$  to the sulfone function could be exploited for control of regiochemistry in alkylations. The yields of the methylated compounds were unoptimized. However one could expect to increase the yields of the various products by modifying one of the three variables in the carbanion chemistry, namely, temperature, reaction times and the use of additives such as HMPA and TMEDA.

The thermolysis of the methylated sulfones 49 and 51 was also briefly studied in refluxing benzene containing a large excess of DHP. In each instance facile extrusion of  $\text{SO}_2$  was observed. The isolated products were easily identified by NMR as the vinylic thiophenes 52 (35%) and 53 (81%), respectively.

$^1\text{H}$  NMR spectrum of compound 53

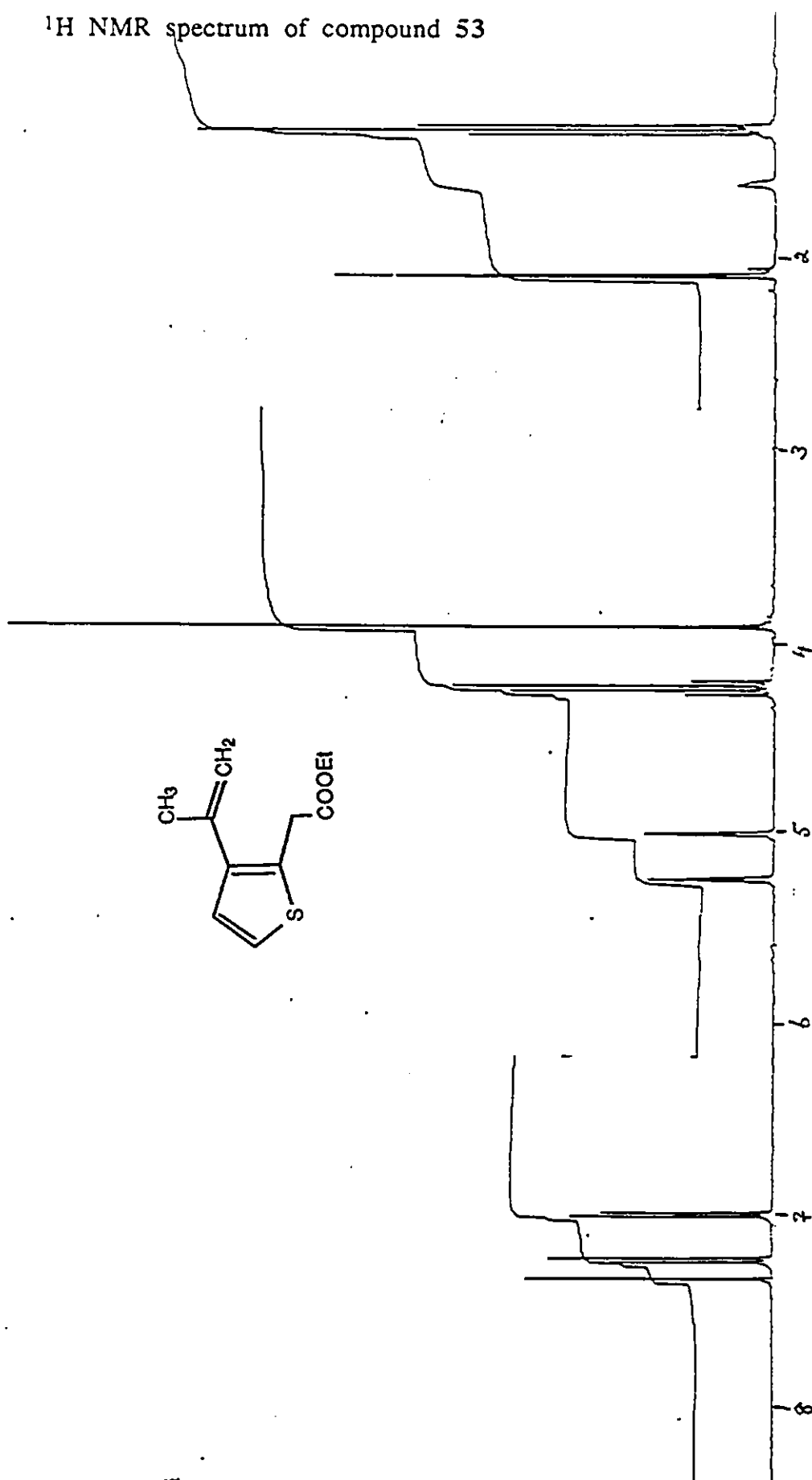

Scheme 14

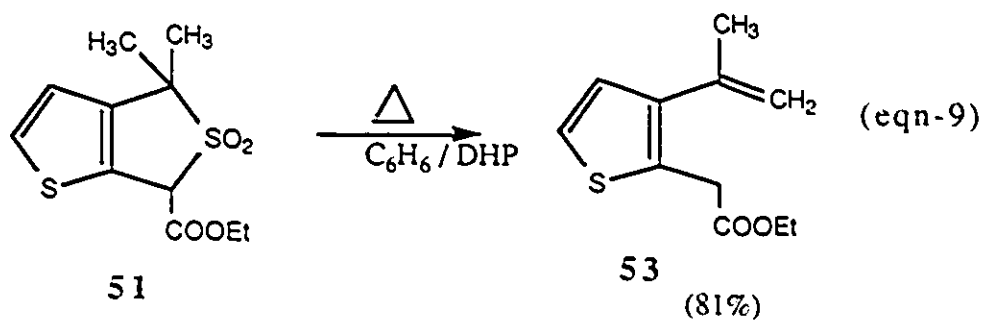
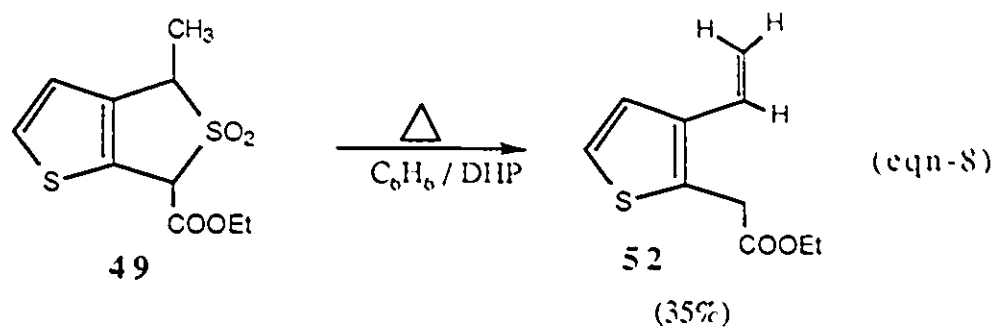

Compound 52 showed its molecular ion peak at  $m/e=196$  ( $M^+$ , 32%) along with a base peak at  $m/e=123$  (loss of ester). Its  $^1\text{H}$  NMR indicated three vinylic proton signals at 6.68, 5.54, and 5.24 and a singlet at 3.8 ppm ( $\text{CH}_2\text{-COOEt}$ ) consistent with the assigned structure. No evidence of trapping of the intermediate diene by the DHP or dimerization was observed. (Scheme 14) Compound 53 was characterized by a molecular ion peak at  $m/e=210$  ( $M^+$ , 36%) with a base peak at  $M^+-73$  due to the loss of the ester group in its mass spectrum. Two vinylic protons were present at 5.2 and 4.98 ppm along with a singlet at 3.8 ppm ( $\text{CH}_2\text{-COOEt}$ ) and a 3H singlet at 2.04

ppm (vinylic methyl) in addition to the ester and thiophene protons. The presence of 11 peaks in  $^{13}\text{C}$  NMR was consistent with **53**.

The products **52** and **53** are the result of a 1,5 sigmatropic rearrangement. In order for this rearrangement to occur the methyl group must be capable of inward rotation to give **55**. Possible routes for interconversion between the two isomeric ortho xylylene, **54** and **55**, are discussed at the end of this section.

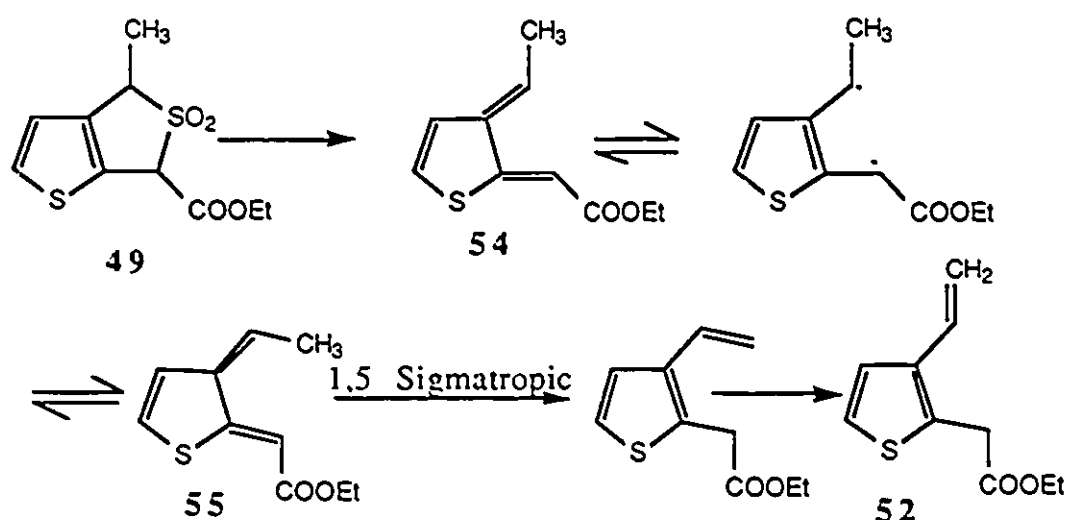

We suspect that the strongly electron withdrawing ester group present on the thiophene xylylene **31** is the culprit for its unreactive nature toward dienophiles. We thought that by substituting a phenyl group for this ester group the reactivity of the thiophene xylylene towards dienophiles might be increased and synthesis of the cyclic sulfone, **60**, was undertaken. Thienyl bromide, on treatment with thiolacetic acid in the presence of potassium hydroxide gave the thioacetate derivative **57**, which was converted into **58** by reduction

with lithium aluminum hydride. Two equivalents of  $n\text{BuLi}$  were used to remove the proton present on the thiol and the proton present at the C-1 position of the thiophene ring. Quenching of this dianion intermediate with one equivalent of benzaldehyde followed by treatment with TFA provided the cyclic sulfide **59**. The sulfide was oxidized to the cyclic sulfone, **60**, with MCPBA. The overall yield of **60** from **56** was approximately 15%. (Scheme 15) The NMR spectrum of **60** had a singlet for two protons at 4.34 ppm was assigned to the methylene protons  $\alpha$  to the sulfone. A singlet present at 5.52 ppm for one proton was assigned to the methine hydrogen flanked by sulfone and phenyl group. In addition, 7 aromatic protons were identified.

Scheme 15

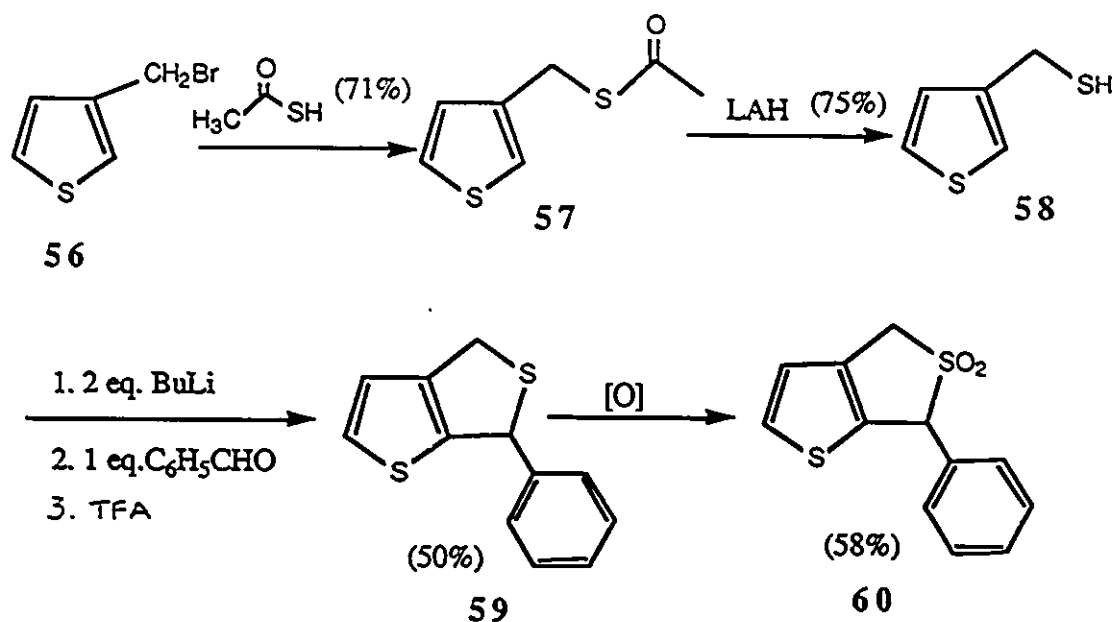

The thiophene sulfone **60** when refluxed in benzene in the presence of dimethylacetylene dicarboxylate afforded after isolation via PTLC using hexane:ethyl acetate (3:1) as the solvent system a 52% yield of the Diels-Alder adduct, **61**. This compound showed three doublets of doublets (ABX patterns) at 3.6 ( $J=6, 24$  Hz), 3.8 ( $J=6, 24$  Hz) (for the two methylene protons) and 5.16 ( $J=6, 6$  Hz) ppm ( $\text{CH}_2\text{-Ph}$ ) in the  $^1\text{H}$  NMR. (See figure 2.) A molecular ion peak was present at  $m/e=296$  (100%) in the mass spectrum as expected for structure **61**.

When dimethyl fumarate was used as a dienophile two diastereoisomers were obtained. A doublet at 4.72 ppm for  $\text{CH}_2\text{-Ph}$  with a 6 Hz coupling constant was present for the isomer **62**; this

was interpreted as being due to a cis arrangement between the benzylic and the adjacent methine proton. In contrast, the benzylic hydrogen of the trans isomer 63 showed a doublet ( $\delta=4.28$ ) with a coupling constant of 12 Hz. The ratio of these two isomers was found to be 1:2. Two sets of methyl ester peaks were present; integration of these peaks gave the same ratio of cis to trans isomers.

The reaction with benzoquinone gave an unexpected result. Analysis of the  $^1\text{H}$  NMR spectrum of the product isolated in 23% yield showed no peaks between 2 and 3 ppm and therefore this product was not the expected Diels-Alder adduct. Three doublets of doublets were present at 3.74, 3.96, and 5.45 ppm with the same coupling constants ( $J=6, 24$  and  $J=6, 6$  Hz) as found in the spectrum of compound 61. These peaks were assigned to the 3 protons remaining on the middle ring. The large allylic coupling constants is characteristic for such ring systems.<sup>19</sup> In the mass spectrum the molecular ion peak was present at  $m/e=292$  (100%) which is 2 mass units less than expected for the Diels-Alder adduct. This showed conclusively that the initially formed 64 was air-oxidized to 65. (Scheme 16)

<sup>1</sup>H NMR spectrum of compound 61

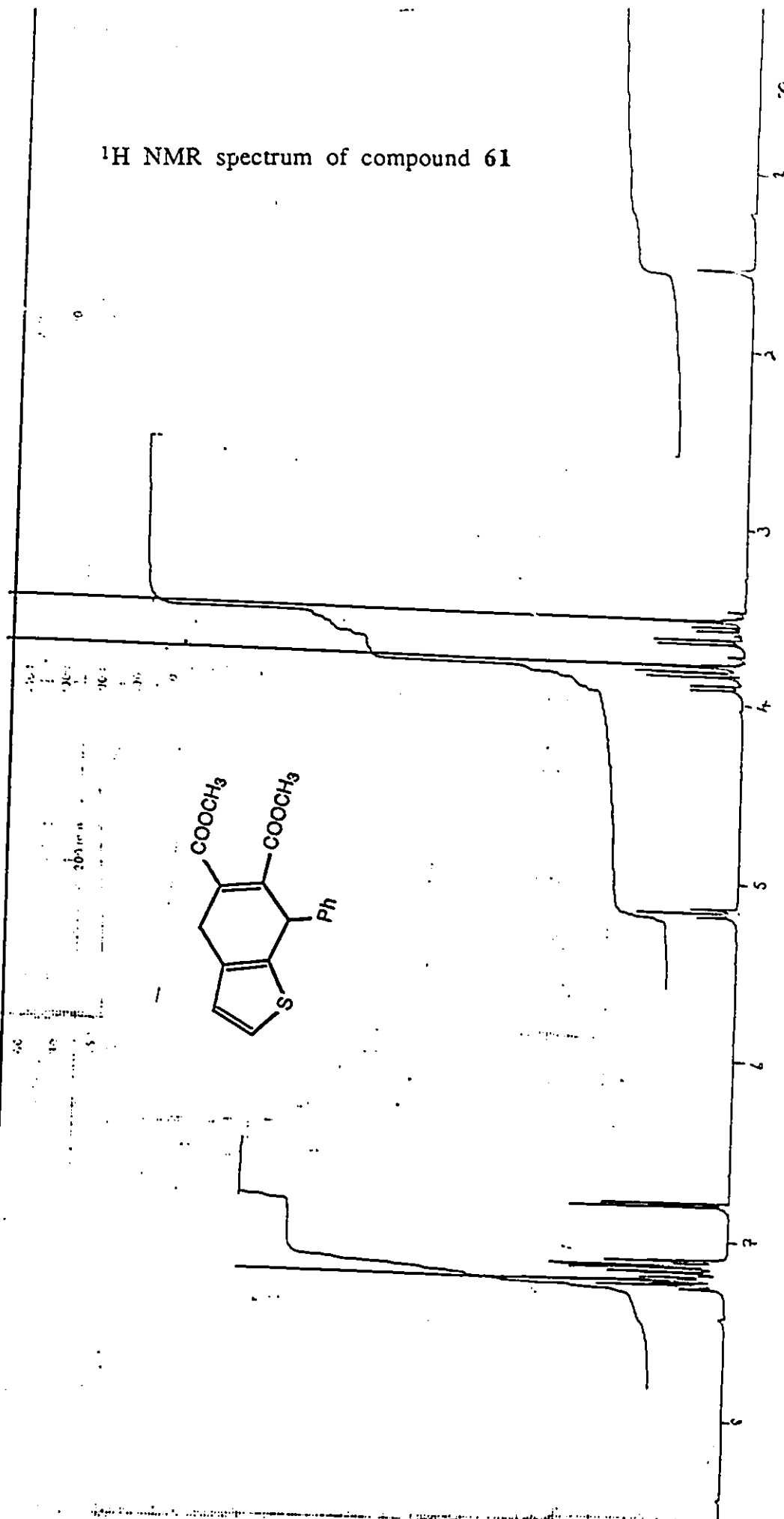

<sup>1</sup>H NMR spectrum of compound 65

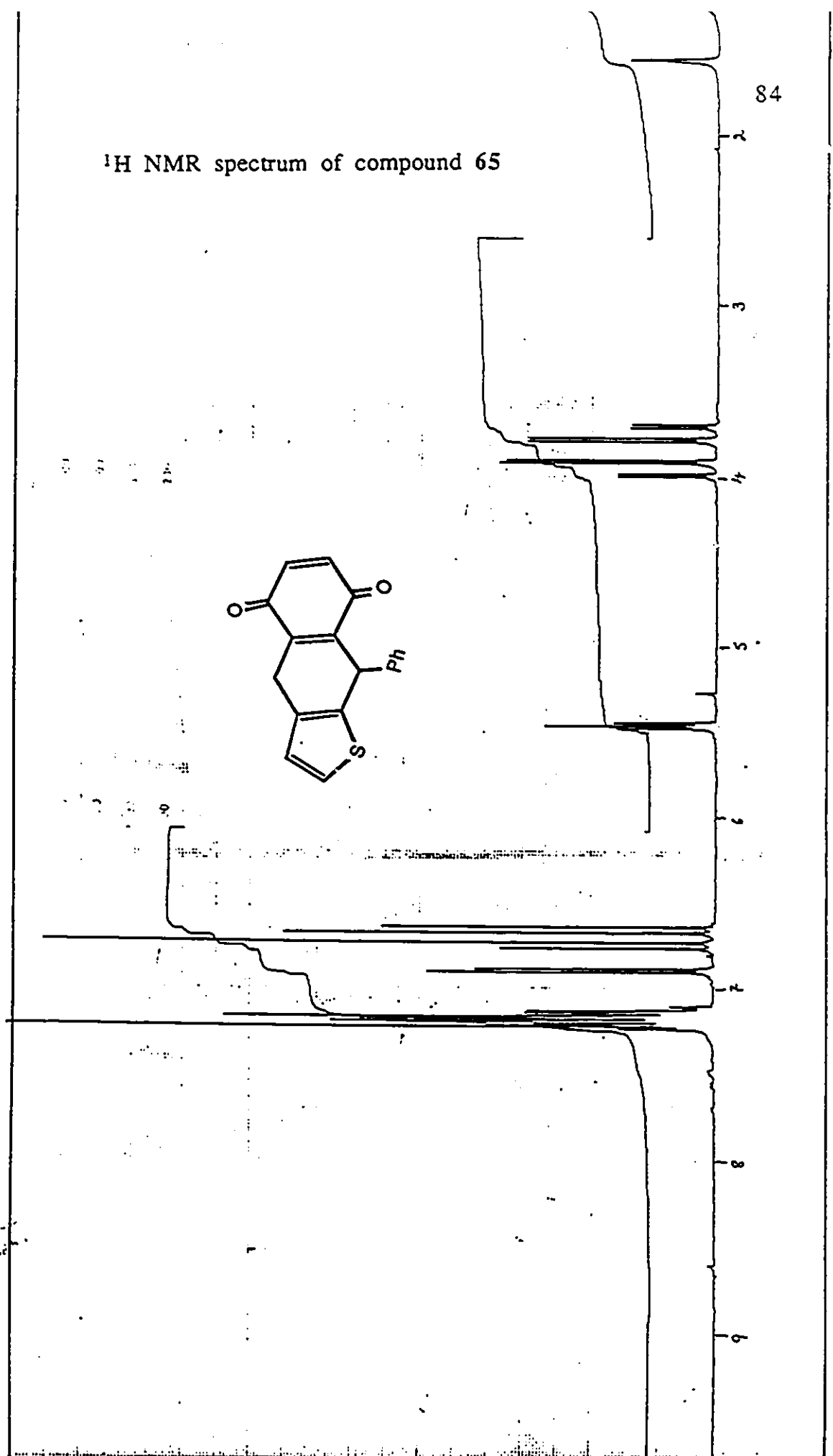
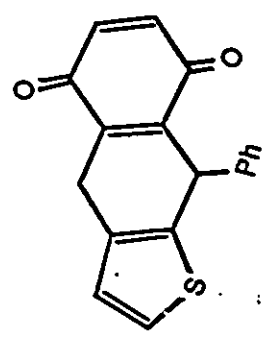

Handwritten notes or markings in the bottom left corner of the page.

Scheme 16

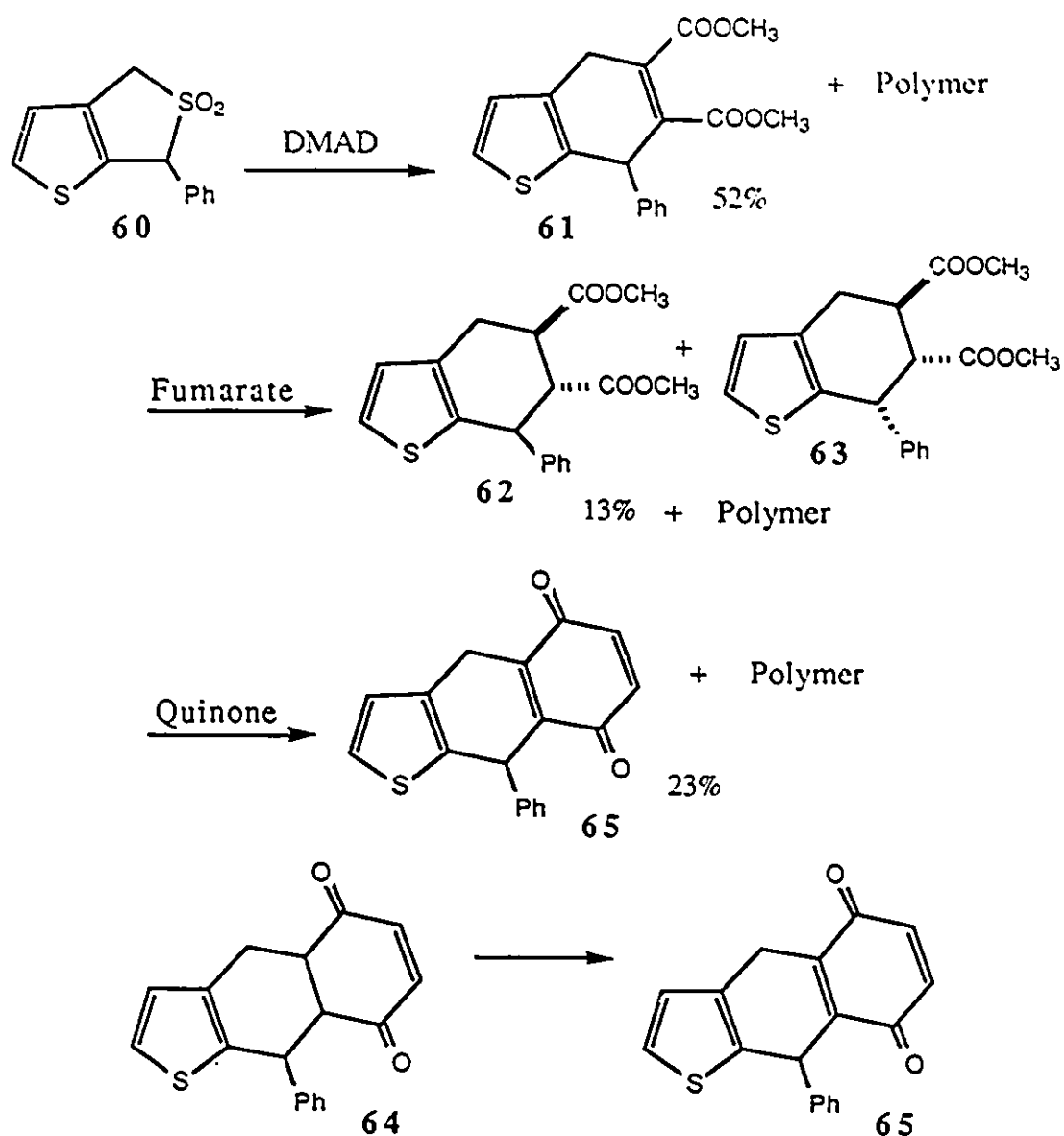

The yields in the above two reactions were quite low (13-52%). Variable amounts of polymers accompanied the products. In the case of the fumarate trapping reaction the low solubility of dimethyl fumarate in refluxing benzene may have contributed to the low

adduct yield.

Due to the moderate level of success in these projects we decided not to pursue these studies further and not to publish our results in scientific journals. Recently Storr et al, a group from England, reported the formation of polymers and dimers in trapping experiments with thiophene xylylenes and essentially verified the above results and conclusions.<sup>20</sup> These authors generated thiophene xylylenes by flash thermolysis of 3-chloromethyl-2-methylthiophene at  $750^{\circ}\text{C}/10^{-2}$  torr. They attempted to trap the thiophene xylylenes in Diels-Alder reactions with various dienophiles including methyl vinyl ketone, methyl acrylate, acrylonitrile, vinyl acetate, methyl vinyl ether, and trichloroethylene and isolated only dimeric and polymeric materials. (Scheme 17) On the other hand, under the same conditions, the analogous furan xylylenes formed the desired Diels-Alder adducts.<sup>21</sup>

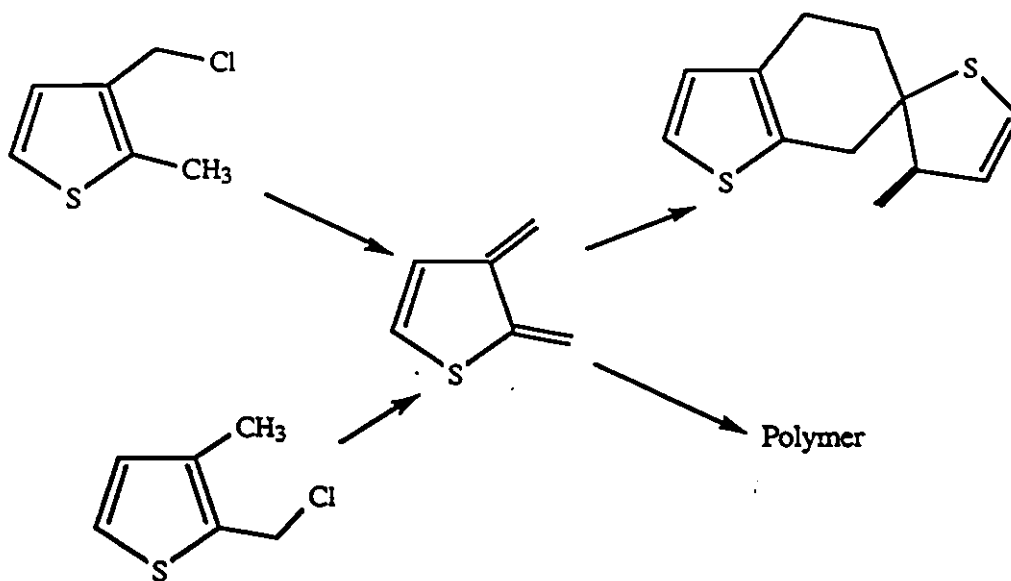

They attributed their failure to observe Diels-Alder adducts in the case of thiophene xylylenes to the instability of these intermediates. According to these authors, the stability of xylylenes is dependent upon the aromaticity of the heterocycle. The greater the aromatic character of the heterocycle, the greater the diradical character of the xylylene and the less reactive it will be as a Diels-Alder diene. Since thiophene has greater aromatic character than furan, the xylylene derived from the former should be less reactive in cycloaddition reactions. Unfortunately this argument does not explain the excellent diene behaviour of orthoquinodimethane.

Furthermore, more recently the same authors reported that thiophene xylylene generated by SO<sub>2</sub> extrusion from the sulfones similar to 60 underwent 4+2 cycloaddition reaction with same dienophiles which we used thereby further weakening the above argument relating diene reactivity to the aromatic character of the

attached ring.<sup>22</sup> Interestingly, thiazole and imidazole xylylenes were reported to undergo polymerization, while oxazole xylylenes formed Diels-Alder adducts.<sup>23</sup>

Trahanovsky et al studied extensively on the reactivity of furan xylylenes. According to these authors dimerization to afford eight membered ring involves a stepwise mechanism via a diradical intermediate. They supported this statement with deuterium isotope studies.<sup>24</sup> (Scheme 18)

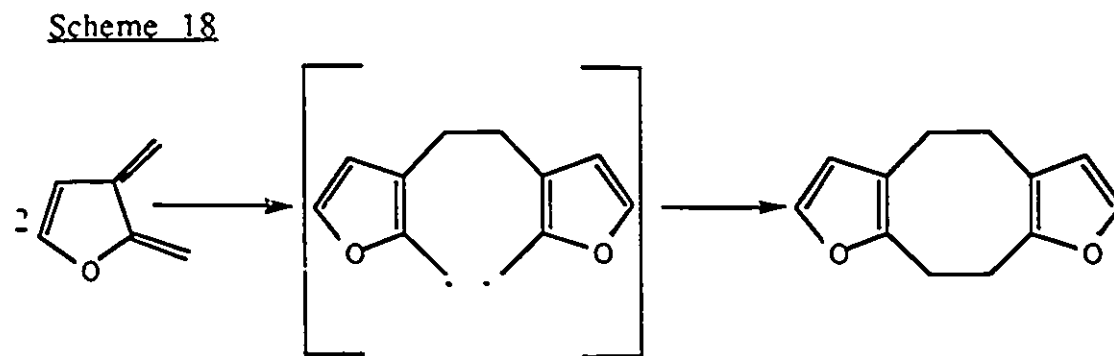

The formation of the dimer 32, in our case, can be explained by head to head radical addition followed by ring closure to give a six-membered ring which is favoured over the formation of a large eight-membered ring. Thus the dimer 32 is not a Diels-Alder product as we had earlier believed. (Scheme 19)

Scheme 19

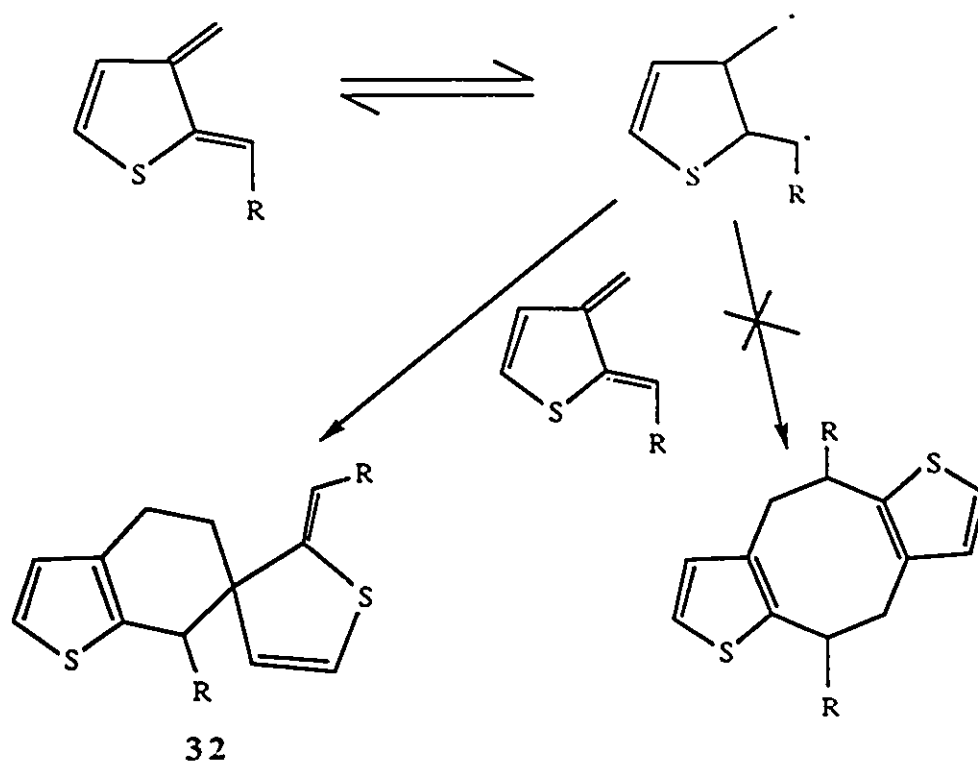

In conclusion, the results generated in our labs two years ago and the recent results from other labs were found to be compatible and identical. We have shown that thiophene xylylenes may not be very effective as Diels-Alder dienes in synthesis until necessary improvements are made to avoid side reactions such as dimerization and polymerization. If this requirement were fulfilled one could synthesize the podophyllotoxin analogue of thiophene from compound 60.

## Experimental Section

### Preparation of Sulfone ester 28

To a solution of thienyl bromide (4.2 g, 23.8 mmol) in EtOH under nitrogen atmosphere, KOH (1.33 g, 23.8 mmol) and ethyl mercaptoacetate (2.86 g, 23.8 mmol) were added sequentially. The reaction mixture was stirred at room temperature for 2 h and then poured into water, extracted with CH<sub>2</sub>Cl<sub>2</sub>, dried and evaporated to give 4.05 g (78%) of crude sulfide. It was used for the next step without further purification and characterization.

A solution of sulfide (4.05 g, 18.75 mmol) was cooled in an ice bath and m-chloroperoxybenzoic acid (10.38 g, 48 mmol) was added in small portions. The mixture was stirred at 0°C for 1.5 h following addition of the peracid; TLC analysis revealed that all of the starting sulfide had been consumed. The mixture was filtered to remove the m-chlorobenzoic acid by-product. The filtrate was washed successively with 10% Na<sub>2</sub>SO<sub>3</sub> and NaHCO<sub>3</sub>, dried and evaporated to give 5.03 g of crude sulfone. On purification by flash chromatography using 5:1 hexane:ethyl acetate as a solvent system 3.8 g (81%) of pure sulfone 28 was obtained as an oil.

<sup>1</sup>H NMR (CDCl<sub>3</sub>) δ 1.30(t, 3H, J=7.2 Hz), 3.60(s, 2H), 4.13(q, 2H, J=7.2 Hz), 4.46(s, 2H), 7.2(m, 3H); IR (neat) cm<sup>-1</sup> 1720, 1120, 1320; ei-MS m/e 248(M<sup>+</sup>, 0.6%), 97(M<sup>+</sup>-151, 100%)

### Preparation of diazo sulfone 29

Sodium hydride was washed with hexane at  $-78^{\circ}\text{C}$  under a nitrogen atmosphere. A solution of sulfone 28 (13.5 g, 54.4 mmole) in dry THF (2 mL/ mmol) and tosyl azide (13 g, 65.9 mmol) were added sequentially at  $-78^{\circ}\text{C}$ . The reaction mixture was allowed to warm to room temperature. Stirring was maintained at room temperature for 3-5 minutes and then the reaction mixture was quenched with saturated  $\text{NH}_4\text{Cl}$  solution, extracted with ether, dried and evaporated. The crude diazo compound thus obtained was further purified by chromatography on silica gel using 5:1 hexane:ethyl acetate as an eluant to afford 4.6 g (31%) of diazo sulfone, 29, an oil.

$^1\text{H}$  NMR ( $\text{CDCl}_3$ )  $\delta$  1.33(t, 3H,  $J=7.2$  Hz), 4.33(q, 2H,  $J=7.2$  Hz), 4.60(s, 2H), 7.33(m, 3H); IR (neat)  $\text{cm}^{-1}$  2120, 1710; ei-MS  $m/e$  97( $\text{M}^+-177$ , 100%).

### Preparation of 4-carbethoxy-4,6-dihydrothieno[3,4-b]thiophene 5,5-dioxide 30

A solution of diazo sulfone 29 (4.6 g, 16.8 mmol) in 50 mL of dry  $\text{CH}_2\text{Cl}_2$  was stirred with 0.45 g of rhodium acetate for 1 h. TLC analysis showed the disappearance of starting material and the formation of the product. The reaction mixture was filtered through a cotton plug and the solvent was evaporated to give the crude product. The crude compound was purified by chromatography on silica gel using 3:1 hexane:ethyl acetate as an eluant to afford 2.1 g (50%) of 30 as a product with mp.  $92^{\circ}\text{C}$ .

$^1\text{H}$  NMR ( $\text{CDCl}_3$ )  $\delta$  7.43(d, 2H,  $J=6.0$  Hz), 6.93(d, 2H,  $J=6.0$  Hz), 5.03(s, 1H), 4.30(m, 4H), 1.30(t, 3H,  $J=7.2$  Hz); IR (neat)  $\text{cm}^{-1}$  1740, 1335, 1200, 1140; ei-MS  $m/e$  246( $\text{M}^+$ , 0.6%), 182( $\text{M}^+-64$ , 66%), 154( $\text{M}^+-92$ , 80%), 97( $\text{M}^+-149$ , 100%); Anal. calcd for  $\text{C}_9\text{H}_{10}\text{O}_4\text{S}_2$ : C, 43.90; H, 4.09. Found: C, 44.10; H, 4.17.

#### Thermolysis of 30 with dimethyl acetylenedicarboxylate

Cyclic sulfone, 30 (50 mg, 0.2 mmol) was dissolved in 4 mL of benzene and was gently refluxed over a period of 3 h and the solvent was evaporated. The residue was purified by PTLC using 3:1 hexane:ethyl acetate as a solvent system to afford 28 mg (69%) of 32 as an oil.

$^1\text{H}$  NMR ( $\text{CDCl}_3$ )  $\delta$  7.18(d, 1H,  $J=5.1$  Hz), 6.82(d, 1H,  $J=5.1$ ), 6.32(dd, 1H,  $J=6.32$ , 0.8 Hz), 5.92(d, 1H,  $J=1.1$  Hz), 5.78(d, H,  $J=6.5$  Hz); IR (neat)  $\text{cm}^{-1}$  1730, 1690, 1650;  $^{13}\text{C}$  NMR  $\delta$  13.9, 14.3, 23.0, 29.2, 50.6, 60.0, 60.3, 61.1, 109.7, 123.8, 124.5, 127.2, 129.4, 135.2, 166.5, 166.8, 170.4; ei-MS  $m/e$  364( $\text{M}^+$ , 16%), 318( $\text{M}^+-46$ , 52%), 291( $\text{M}^+-73$ , 42%), 290( $\text{M}^+-74$ , 49%), 154( $\text{M}^+-210$ , 100%); A HR-MS  $\text{M}^+$  calcd 364.0218, found 364.0822.

#### Alkylation of 30 with n-BuLi and MeI (47)

To a solution of cyclic sulfone 30 (0.15 g, 0.6 mmol) in THF at  $-78^\circ\text{C}$ , 0.25 mL of 2.4 M n-BuLi was added. The reaction mixture was stirred at  $-78^\circ\text{C}$  for 30 minutes and then 1 mL of MeI was added. The reaction mixture was allowed to warm to room temperature and stirred for 2 h. The solution was quenched with saturated  $\text{NH}_4\text{Cl}$  solution, extracted with ether and dried. Removal of solvent followed

by flash chromatograph using 5:1 hexane:ethyl acetate as an eluant afforded 100 mg (60%) of white solid with mp. 88°C.

$^1\text{H}$  NMR ( $\text{CDCl}_3$ )  $\delta$  7.43(d, 1H, J=6.0 Hz), 6.90(d, 1H, J=6.0 Hz), 4.33(s, 2H), 4.30(q, 2H), 1.90(s, 3H), 1.33(t, 3H, J=7.0 Hz); IR ( $\text{CHCl}_3$ )  $\text{cm}^{-1}$  1740, 1330.

#### Preparation of 49 from 30

To a solution of cyclic sulfone 30 (0.15 g, 0.6 mmol) in THF at -78°C, 0.56 mL of 2.4 M n-BuLi was added. The reaction mixture was stirred at -78°C for 1 h. The reaction mixture was allowed to warm to room temperature and stirred for 1 h. Once again, the reaction mixture was cooled to -78°C and MeI (0.6 mmol) was added. Stirring was maintained at -78°C for 1 h after which the reaction mixture was quenched with  $\text{NH}_4\text{Cl}$  solution, extracted with ether, dried and evaporated to give 0.15 g of crude product. Purification with silica gel chromatography afforded 56 mg (32%) of the methylated sulfone, 49, as a mixture of isomers mp. 91°C.

$^1\text{H}$  NMR ( $\text{CDCl}_3$ )  $\delta$  7.43(d, 1H, J=6.0 Hz), 6.90(d, 1H, J=6.0 Hz), 5.03(m, 1H), 4.26(m, 3H), 1.63(d, 3H, J=7.2 Hz), 1.33(t, 3H, J=7.2 Hz); IR ( $\text{CHCl}_3$ )  $\text{cm}^{-1}$  1740, 1330.

#### Reaction of 30 with n-BuLi and MeI (51)

To a solution of cyclic sulfone 30 (70 mg, 0.28 mmol) in THF at -78°C, 0.4 mL of 2.4 M n-BuLi was added. The reaction mixture stirred for 30 minutes at -78°C and MeI (0.6 mmol) was added. The reaction mixture was allowed to warm to room temperature and stirred for 2 h. Extractive workup was carried out as described in 49,

the crude material was purified by flash chromatography using 5:1 hexane:ethyl acetate to afford 35 mg (45%) of white solid, mp. 82°C. <sup>1</sup>H NMR (CDCl<sub>3</sub>) δ 7.43(d, 1H, J=6.0 Hz), 6.68(d, 1H, J=6.0 Hz), 5.05(s, 1H), 4.28(q, 2H, J=7.2 Hz), 1.67(s, 6H), 1.33(t, 3H, J=7.2 Hz); IR (CHCl<sub>3</sub>) cm<sup>-1</sup> 1740, 1330; ei-MS m/e 210(M<sup>+</sup>, 49%), 137(M<sup>+</sup>-137, 100%).

#### Thermolysis of 49 with dihydropyran as a dienophile

Cyclic sulfone 49 (50 mg) was dissolved in 5 mL of benzene and 4 mL of dihydropyran. The reaction mixture was gently refluxed for 5 h. The reaction mixture was concentrated and chromatographed on silica gel using 5:1 hexane:ethyl acetate as a solvent system to afford 13 mg (35%) of 52, an oil.

<sup>1</sup>H NMR (CDCl<sub>3</sub>) δ 7.16(d, 1H, J=5.4 Hz), 7.12(d, 1H, J=5.4 Hz), 6.68(dd, 1H, J=17.4, 10.5 Hz), 5.54(dd, 1H, J=17.4, 1 Hz), 5.24(dd, 1H, J=10.5, 1 Hz), 4.16(q, 2H, J=7.2 Hz), 3.80(s, 2H), 1.26(t, 3H, J=7.2 Hz); IR (neat) cm<sup>-1</sup> 2980, 1740, 1180; ei-MS m/e 196(M<sup>+</sup>, 32%), 123(M<sup>+</sup>-73, 100%); A HR-MS calcd 196.0555, found 196.0556.

#### Thermolysis of 51 with dihydropyran as a dienophile

A cyclic sulfone 51 (65 mg) was dissolved in a mixture of 5 mL of benzene and 4 mL of dihydropyran. The reaction mixture was gently refluxed for 5 h. After the removal of solvent the crude compound was chromatographed on silica gel using 5:1 hexane:ethyl acetate as an eluant to afford 45 mg (81%) of 53, an oil.

<sup>1</sup>H NMR (CDCl<sub>3</sub>) δ 7.18(d, 1H, J=5.4 Hz), 6.95(d, 1H, J=5.4 Hz), 5.20(d, 1H, J=3.5 Hz), 4.98(d, 1H, J=3.5 Hz), 4.19(q, 2H, J=7.5 Hz), 3.88(s, 2H), 2.04(s, 3H), 1.28(t, 3H, J=7.5 Hz); <sup>13</sup>C NMR δ 14, 24, 34, 61, 115, 123,

127, 129, 139, 142, 170; IR (neat)  $\text{cm}^{-1}$  2980, 1740, 1180; ei-MS  $m/e$  210( $M^+$ , 36%), 137( $M^+-73$ , 100%) A HR-MS calcd 210.0711, found 210.0702.

#### Preparation of thioester 57

To a solution of thienyl bromide (11.6 g, 65.9 mmol) in EtOH (2 mL/mmol) under a nitrogen atmosphere, KOH (3.7 g, 66 mmol) and thiolacetic acid (8.7 mL, 79 mmol) were added sequentially. The reaction mixture was stirred at room temperature for 2 h and then poured into water, extracted with  $\text{CH}_2\text{Cl}_2$ , washed with 10% NaOH, dried and evaporated to give 11.5 g crude product. It was purified by chromatography on silica gel using 20:1 hexane:ether to afford 8.0 g (71%) of the pure product as an oil.

$^1\text{H NMR}$  ( $\text{CDCl}_3$ )  $\delta$  7.05(m, 3H), 4.10(s, 2H), 2.20(s, 3H).

#### Preparation of 2-mercaptomethylthiophene, 58

To a solution of thioester (0.5 g, 2.9 mmol) in ether was added  $\text{LiAlH}_4$  (0.14 g, 3.48 mmol) at  $-78^\circ\text{C}$ . The reaction mixture was allowed to warm to room temperature. It was stirred at room temperature for 10 minutes, at which point TLC indicated the disappearance of the starting material. The reaction mixture was cooled to  $-78^\circ\text{C}$ , 3N HCl was added dropwise, and poured into water. The organic layer was dried and evaporated to give 0.28 g (75%) of 58 an oil.

$^1\text{H NMR}$  ( $\text{CDCl}_3$ )  $\delta$  7.05(m, 3H), 3.66(d, 2H,  $J=7.0$  Hz), 1.73(t, 1H,  $J=7.0$  Hz); ei-MS  $m/e$  130( $M^+$ , 30%), 97( $M^+-29$ , 100%).

### Preparation of 59

To a stirred solution of thiol 58 (2 g, 15.3 mmol) in THF, 2.2 equiv of nBuLi (2.4 M, 14 mL) was added at -78°C. The stirring was continued for 15 minutes at -78°C and benzaldehyde was added. The reaction mixture was stirred at -78°C for an additional 30 minutes and then quenched with saturated NH<sub>4</sub>Cl and extracted with ether. The ether layer was acidified with 3 mL of conc. trifluoroacetic acid and stirred for 10 minutes. The organic layer was washed successively with water, 5% NaHCO<sub>3</sub>, and saturated NaCl, dried and evaporated to give 1.8 g (50%) of cyclic sulfide 59 as an oil.

<sup>1</sup>H NMR (CDCl<sub>3</sub>) δ 7.20(m, 6H), 6.80(d, 1H, J=6.0 Hz), 5.60(t, 1H, J=4.0 Hz), 4.06(m, 2H); ei-MS m/e 218(M<sup>+</sup>, 100%), 184(M<sup>+</sup>-34, 60%), 141(M<sup>+</sup>-77, 27%).

### Preparation of cyclic sulfone 60

A solution of cyclic sulfide 59 (1.0 g, 4.58 mmol) in 20 mL of CH<sub>2</sub>Cl<sub>2</sub> was cooled in an ice bath and MCPBA (2.16 g, 10 mmol) was added. The reaction mixture was stirred at 0°C for 2 h. The mixture was filtered to remove the m-chlorobenzoic acid by-product. The filtrate was washed successively with 10% Na<sub>2</sub>SO<sub>3</sub> and 5% NaHCO<sub>3</sub>, dried and evaporated to give 0.66 g (58%) of product as a white solid of mp. 68°C.

<sup>1</sup>H NMR (CDCl<sub>3</sub>) δ 7.50(d, 1H, J=5.6 Hz), 7.40(m, 4H), 7.02(d, 1H, J=5.6 Hz), 5.52(s, 1H), 4.34(s, 2H); IR (CHCl<sub>3</sub>) cm<sup>-1</sup> 2990, 1320, 1120; ei-MS m/e 184(M<sup>+</sup>-64, 83%), 185(M<sup>+</sup>-65, 100%), 64(M<sup>+</sup>-184, 52%).

#### Thermolysis of 60 with Dimethyl acetylenedicarboxylate

Cyclic sulfone 60 (30 mg) was dissolved in a mixture of 4 mL of benzene and 1 mL of dimethyl acetylenedicarboxylate. The reaction mixture was gently refluxed for a period of 6 h. After removal of the solvent the residue was purified with PTLC using 4:1 hexane:ethyl acetate as a solvent system to afford 18 mg (52%) of adduct 61, an oil.

$^1\text{H NMR}$  ( $\text{CDCl}_3$ )  $\delta$  7.20(m, 6H), 6.80(d, 1H,  $J=6$  Hz), 5.16(t, 1H,  $J=6$  Hz), 3.88(dd, 1H,  $J=6, 24$  Hz), 3.80(s, 3H), 3.60(dd, 1H,  $J=6, 24$  Hz), 3.54(s, 3H); IR (neat)  $\text{cm}^{-1}$  1720, 1420; ei-MS  $m/e$  328( $\text{M}^+$ , 4.2%), 296( $\text{M}^+-32$ , 100%), 237( $\text{M}^+-91$ , 62%).

#### Thermolysis of 60 with Benzoquinone

To a solution of cyclic sulfone 60 (30 mg) in 5 mL benzene was added 45 mg of benzoquinone. The reaction mixture was refluxed for a period of 6 h and the solvent was removed. The crude compound was purified by PTLC using 3:1 hexane:ethyl acetate as a solvent system to afford 8 mg (23%) of 65.

$^1\text{H NMR}$  ( $\text{CDCl}_3$ )  $\delta$  7.20(m, 6H), 6.90(d, 1H,  $J=6$  Hz), 6.76(d, 1H,  $J=12$  Hz), 6.66(d, 1H,  $J=12$  Hz), 5.45(dd, 1H,  $J=6$  Hz), 3.96(dd, 1H,  $J=6, 24$  Hz), 3.74(dd, 1H,  $J=6, 24$  Hz); IR ( $\text{CHCl}_3$ )  $\text{cm}^{-1}$  3058, 2990, 1660; ei-MS  $m/e$  292( $\text{M}^+$ , 100%).

Thermolysis of 60 with Dimethyl fumarate

To cyclic sulfone 69 (25 mg) in 8 mL of benzene was added 60 mg of dimethyl fumarate after which it was refluxed for 6 h. After removal of the solvent the crude compound was purified by PTLC using 3:1 hexane:ethyl acetate to afford 3.9 mg (13%) of adduct, an oil.

$^1\text{H}$  NMR ( $\text{CDCl}_3$ )  $\delta$  7.4-6.7(m, 7H), 4.72(d,  $J=6$  Hz) and 4.28(d,  $J=12$  Hz); 1H total, 3.68(s) and 3.66(s); 3H total, 3.48(s) and 3.44(s); 3H total, 3.3-2.7(m, 4H); IR (neat)  $\text{cm}^{-1}$  2770, 1735, 1200; ei-MS  $m/e$  330( $\text{M}^+$ , 1.4%), 270( $\text{M}^+-60$ , 48%), 211( $\text{M}^+-119$ , 100%).

## References

1. M.P. Cava, M.J. Mitchell, A.A. Deana, *J. Org. Chem.*, 1960, **25**, 1481.
2. W. Oppolzer, D.A. Roberts, *Helv. Chim. Acta.*, 1980, **63**, 1703.
3. K.C. Nicolaou, W.E. Barnette, P. Ma, *J. Org. Chem.*, 1980, **45**, 1463.
4. J.M. Mann, S.E. Piper, L.K.P. Yeung, *J. Chem. Soc., Perkin Trans.*, 1984, 2081.
5. J.L. Charlton, M.M. Alauddin, *J. Org. Chem.*, 1986, **51**, 3490.
6. J.L. Charlton, M.M. Alauddin, *Tetrahedron*, 1987, **43**, 2873.
7. W. Oppolzer, *Tetrahedron Letts.* 1974, 1001.
8. T. Kametani, H. Nemoto, H. Ishikawa, K. Shiroyama, H. Matsumoto, H. Fukumoto, *J. Amer. Chem. Soc.*, 1977, **99**, 3461.
9. D.I. McDonald, T. Durst, *J. Org. Chem.*, 1986, **51**, 4750.
10. Y. Ito, M. Nakatsuka, T. Saegusa, *J. Amer. Chem. Soc.*, 1980, **102**, 863.
11. Y. Ito, Y. Amino, M. Nakatsuka, T. Saegusa, *J. Amer. Chem. Soc.*, 1983, **105**, 1590.
12. Y. Ito, Y. Amino, M. Nakatsuka, T. Saegusa, *J. Amer. Chem. Soc.*, 1983, **105**, 1586.
13. T. Gallagher, P. Magnus, J.C. Hoffmann, *J. Amer. Chem. Soc.*, 1982, **104**, 1140.
14. H. Straflor, J. Skramstad, S. Nordenson, *J. Chem. Soc. Chem. Commun.*, 1984, 208.
15. E. Wenkert, L.L. Davis, B.L. Mylari, M.F. Solomon, R.R. da Silva, S. Shulman, R.J. Warnet, P. Ceccherelli, M. Curini, R. Pellicciari, *J. Org. Chem.*, 1983, **47**, 3242.

16. D.F.Taber, R.E.Ruckle, *Tetrahedron Lett.*, 1985, 26, 3059.
17. Z.Khan, T.Durst, *Can. J. Chem.*, 1987, 65, 482.
18. J.L.Charlton, T.Durst, *Tetrahedron Lett.*, 1984, 25, 2663.
19. Durham.L.J., J.Studebaker, M.J.Perkins, *J. Chem. Soc., Chem. Comm* , 1965, 456.
20. P.M.S. Chauhan, G. Jenkins, S.M. Walker. R.C. Storr, *Tetrahedron Lett.*, 1981, 29, 117.
21. W.S. Trahanovsky, T. J. Cassady, T.L. Woods, *J. Amer. Chem. Soc.*, 1981, 103, 6691.
22. A.P.A. Crew, G.Jenkins, R.C.Storr, M.Yelland, *Tetrahedron Letts*, 1990, 31, 1491.
23. P.M.S. Chauhan, A.P.A. Crew, G. Jenkins, R.C. Storr, S.M. Walker, M. Yelland, *Tetrahedron Lett.*, 1990, 31, 1487.
24. C.H.Chou, W.S. Trahanovsky, *J. Amer. Chem. Soc.*, 1986, 108, 4138.

## CHAPTER 3

### Intramolecular Rhodium Carbenoid Insertions into Aromatic C-H Bonds\*

#### Introduction

After the successful synthesis of the thiophene sulfone precursor to thiophene xylylene (Chapter 2) we decided to investigate the generality of the aromatic C-H diazo insertion reactions\* of  $\alpha$ -diazo- $\beta$ -sulfonyl esters into various other heterocyclic rings. This methodology might prove useful for generating several heterocyclic xylylenes such as 1a to 1e. (Scheme 1)

---

\* The terms "rhodium carbenoid C-H insertion" and "electrophilic aromatic substitution" are used interchangeably in this chapter. A discussion of the mechanism of these reactions is given in Chapter 4.

Scheme 1

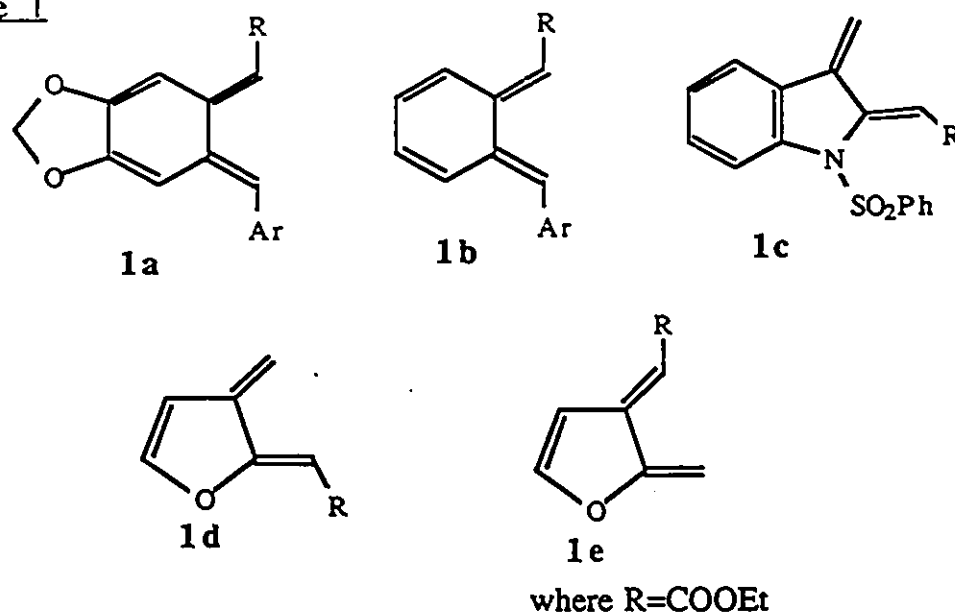

Aliphatic insertion reactions involving rhodium carbenoids have been well studied and are used extensively in synthesis. Diazo insertions into O-H, N-H, and S-H bonds as well as formation of cyclopropanes from alkenes are also well understood and have been exploited in synthetic chemistry. Recent reviews by Doyle and Mass are available.<sup>1</sup> On the other hand, aromatic C-H insertion reactions had not been studied in much detail or applied in synthetic organic chemistry.

The xylylenes 1a to 1e which can be generated from the cyclic sulfones 2a to 2e are of considerable synthetic interest. Xylylenes such as 1a and 1b (R=H) have been used in the preparation of podophyllotoxin analogues and members of the lignan family.<sup>2</sup> Magnus used xylylenes similar to 1c in the synthesis of aspidospermidine (Chapter 2).<sup>3</sup> Several other alkaloids might also be prepared from this xylylene. Valuable sesquiterpenes containing a

cyclohexane fused to a furan ring may be accessible from the xylylenes 1d and 1e (Scheme 2).<sup>4</sup>

Scheme 2

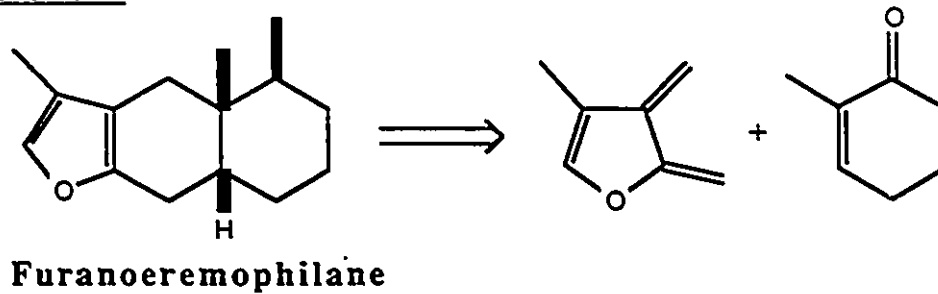

## Discussion and Results

## Preparation of 2,5-dihydrothiophenes fused to aromatic rings

Scheme 3

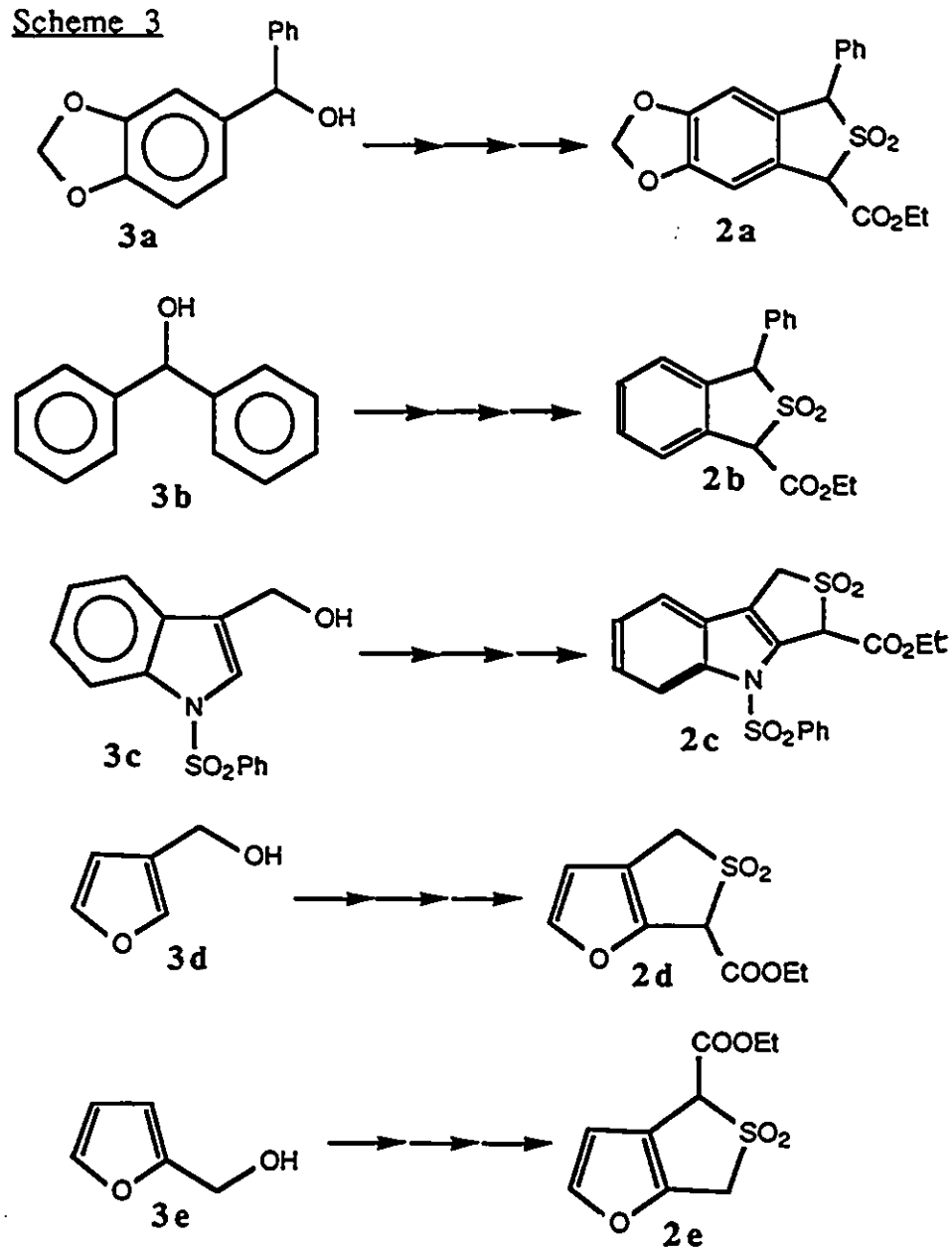

The alcohols 3 a-e required for the generation of the diazosulfones 6 a-e were either commercially available or were synthesized. The synthesis of compounds 6 a-e is shown in the generalized Schemes 3 and 4.  $\alpha$ -Phenylpiperonal, 3a, was prepared from piperonal and phenylmagnesium bromide via a simple Grignard reaction. Benzophenone, on reduction with sodium borohydride, furnished 1,1-diphenylmethanol 3b. 3-Hydroxymethylindole, 3c, was obtained from the reduction of indole-3-carboxaldehyde. 3-Hydroxymethylfuran (3d) and 2-hydroxymethylfuran (3e) were purchased from Aldrich.

Scheme 4

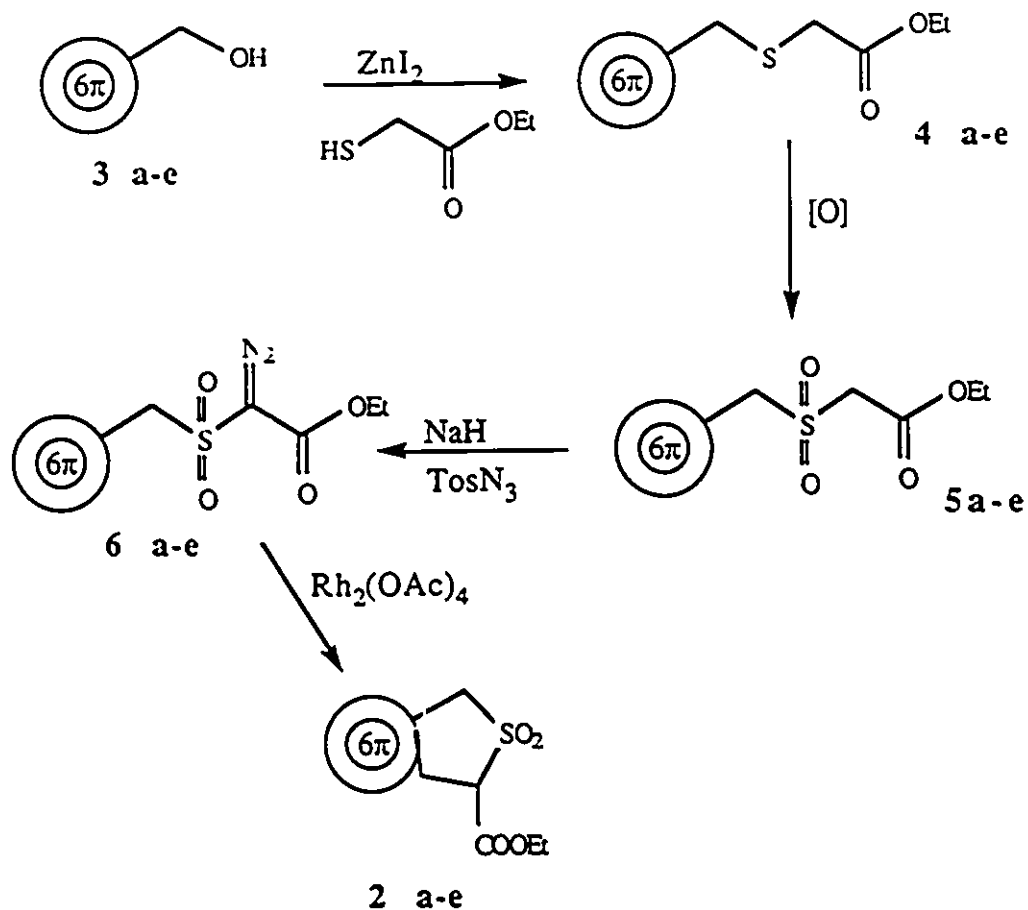

The sulfone esters 2 a-e were prepared by the standard procedures outlined below. The compounds 3 a-e were converted into 4 a-e by a one-pot reaction using zinc iodide and ethyl mercaptoacetate. This attractive reaction was developed by Gauthier and Young from Merck-Frosst.<sup>5</sup> It is much superior to the conventional reaction in which the hydroxyl group is first converted into a halide which is then displaced with a sulfur nucleophile. The sulfides 4 a-e obtained from the above reaction were oxidized into

the sulfones without further purification using MCPBA in methylene chloride at 0° C. The sulfones were identified easily by <sup>1</sup>H NMR. After oxidizing the sulfide to the sulfone, the peak for the methylene protons α to the aromatic ring shifted downfield from δ=3.7-3.9 ppm to 4.6 ppm, and the peak for the active methylene group flanked by the sulfur atom and the ester group shifted from 2.9-3.1 ppm to 3.8-4.0 ppm. Yields and more detailed spectroscopic data are given in the Experimental Section.

Sulfones 5 a-e were converted into diazo sulfones by treatment with sodium hydride and tosyl azide in THF. In the IR spectrum the characteristic signal for the diazo group appeared at 2120 cm<sup>-1</sup>. After introduction of the the diazo group, the peak for the active methylene group observed by <sup>1</sup>H NMR at 3.8-4.0 ppm in the sulfone, completely disappeared. These two spectroscopic features are the key elements for the identification of diazo compounds. The yields of the reactions were found to be in the range of 23 to 43%. Mesyl azide is known to give better yields in diazo transfer reactions; however, we used tosyl azide as it has the advantage of being a very safe reagent to handle. Recently, Danheiser from MIT reported high yields for diazo transfer reactions using trifluoroethyl trifluoroacetate and mesyl azide.<sup>6</sup> The yield from this diazo reaction is reported to be much superior to that obtained from conventional diazo transfer reactions.<sup>7</sup> Since this was essentially a survey of the reactivity of these diazo sulfones, we were not highly concerned with these modest yields. If large quantities of α-diazosulfones are needed at the beginning of a lengthy synthetic sequence the above alternate methods should be investigated. Diazo compounds 6 a-c, on

treatment with 5-10 mole % rhodium acetate in methylene chloride at room temperature, underwent diazo insertion reactions to give the expected products 2 a-c. (Table I)

**Table I**

Entry	Diazo Compound	Product	Yield
1			52, 74
2			47
3			24

When diazo compound 6a, in methylene chloride, was treated with rhodium acetate nitrogen gas evolution occurred slowly. After 3 h of stirring, the rhodium acetate was filtered off and the solvent was evaporated to provide the crude product. Purification on silica gel provided product 2a which was identified by  $^1\text{H}$  NMR and IR spectroscopy. The IR spectrum showed the disappearance of the diazo peak at  $2120\text{ cm}^{-1}$  and a shifting of the carbonyl peak from

1710  $\text{cm}^{-1}$  in the diazo compound to 1740  $\text{cm}^{-1}$  which indicated the presence of a cyclized product.

In principle, the carbenoid formed from **6a** inserts either ortho ( $\text{C}_2$ ) or para ( $\text{C}_6$ ) to the existing methoxymethylene group or into the unsubstituted phenyl group. In fact, we isolated only one regioisomer (a mixture of diastereoisomers), arising from aromatic C-H insertion para ( $\text{C}_6$ ) to the methoxymethylene group.

In the  $^1\text{H}$  NMR spectrum the product was found to be a mixture of two diastereoisomers, namely cis and trans. The ratio of the two diastereoisomers obtained from the reaction of **6a** was determined to be 1:2.5 by integration of the two sets of singlets at 5.1 ppm ( $\text{Ph-CH-SO}_2$ ) and 5.5 ppm ( $\text{COOEt-CH-SO}_2$ ), each set being assigned 1H. A singlet at 5.64 ppm was assigned to the cis isomer while a singlet at 5.43 ppm was assigned to the trans isomer. Due to the shielding effect of the ring the trans proton appeared further upfield. A doublet at 6.0 ppm was assigned to the methylenedioxy group. Singlets present at 6.8 ppm and 6.5 ppm (for two diastereoisomers) clearly indicate the presence of only one regioisomer. In addition, 5 aromatic protons and 5 ester protons were identified.

Similarly, when **6b** was treated with rhodium acetate under the above mentioned conditions it formed a product which had singlets at 5.7 and 5.2 ppm. On integration, the ratio of the two isomers was determined to be 1:2.5. Compound **2c**, an indole derivative, was obtained from diazo compound **6c** on treatment with rhodium acetate. Its  $^1\text{H}$  NMR spectrum contained a peak at  $\delta = 6.59$  ppm (d,  $J=3.3$  Hz) which was assigned to the methine proton flanked by the sulfone and ester groups. Signals present at 5.35 ppm (dd,

J=3.3, 7.4 Hz) and 4.76 ppm (d, J=7.4 Hz) were assigned to the methylene protons  $\alpha$  to the sulfone. In addition, 9 aromatic protons and 5 ester protons were identified. During this period, M. Hrytsak in our labs prepared several sulfones precursor to 1-carbethoxy-o-quinodimethanes, bearing a variety of substituents on the aromatic ring, via a rhodium carbenoid aromatic C-H bond insertion reaction. (Table II) He essentially used the same methodology described in Scheme 4.

<sup>1</sup>H NMR Spectrum of compound 2c

Table II

Entry	Diazo Compound	Product	Yield
1.			46
2.			48
3.			14
4.			45
5.			42

Use of rhodium trifluoroacetate instead of rhodium acetate as a catalyst in the diazo insertion reaction of 6a (entry 1, Table I) increased the yield of cyclization product from 52% to 74%. The

beneficial effect of the rhodium trifluoroacetate may be due to the increased reactivity of the carbenoid when the rhodium bears more electron-withdrawing ligands. It is reasonable to assume that similar increases in the yields of the insertion products listed in Table I and II would be observed if rhodium trifluoroacetate were substituted for rhodium acetate. However, we did not repeat this experiment for any of the other diazo insertion reactions listed in Table I or II.

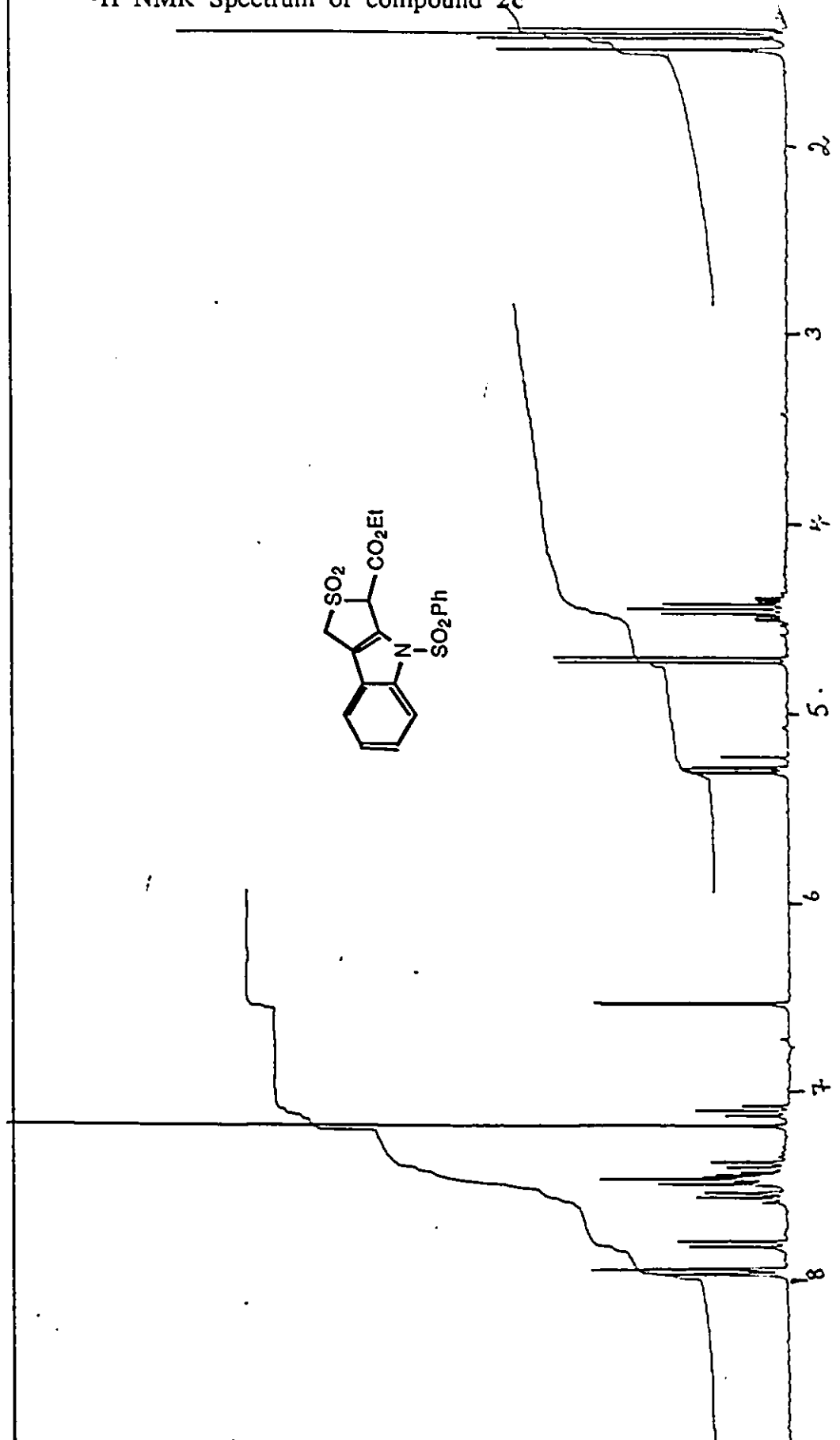
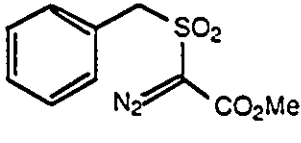
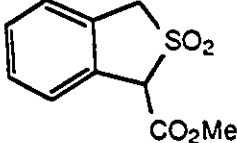
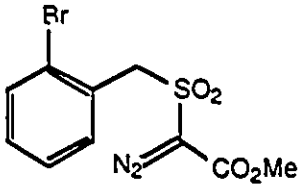
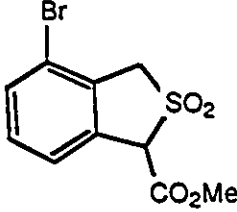
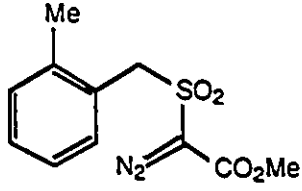
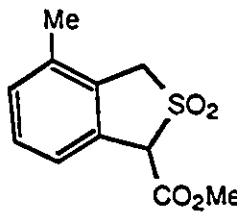
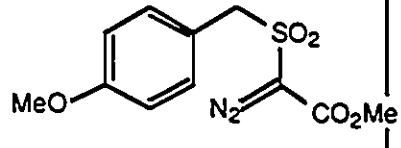
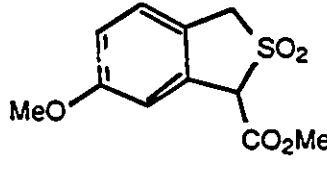
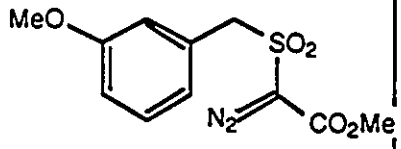
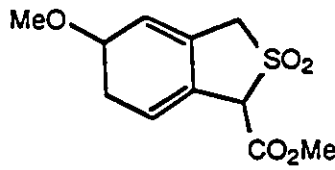
In contrast to the above examples, treatment of diazo compound **6e**, which carries a pendant furan group rather than an aromatic ring, with rhodium acetate in methylene chloride at room temperature afforded an unsaturated aldehyde. The aldehyde **8** was recovered after removal of the rhodium acetate by filtration and evaporation of the solvent from the reaction mixture. The 200 MHz  $^1\text{H}$  NMR spectrum of **8** showed, in addition to the ethyl group, a 2H singlet at  $\delta = 4.4$  ppm assigned to the methylene group of the thiete sulfone ring, a doublet of doublets at 6.45 ppm ( $J = 12, 6.3$  Hz), a doublet at 7.68 ppm ( $J = 12$  Hz), and a doublet at 10.16 ppm ( $J = 6.3$  Hz) due to the trans  $\alpha, \beta$  unsaturated aldehyde unit. The yield of this product was 81%. (Scheme 5)

Similarly, in the reaction of diazo compound **6d** in the presence of rhodium acetate, an unsaturated aldehyde, **7**, was obtained in greater than 95% yield. The NMR spectrum allowed us to assign the structure. Signals present at 1.4 ppm (t,  $J = 7$  Hz, 3H) and 4.24 ppm (d,  $J = 1.3$  Hz, 2H) were assigned to the ester protons. A doublet present at 10.16 ppm (d,  $J = 6$  Hz, 1H) was assigned to the aldehyde proton. This proton was clearly coupled to the proton present at 6.3 ppm (dd,  $J = 6, 1.3$  Hz, 1H) which was assigned to the proton present at the double

bond  $\alpha$  to the aldehyde. A singlet at 8.50 ppm was assigned to a proton present at the double bond  $\beta$  to the ester group. the remaining two protons present at 4.24 ppm (d,  $J=1.3$  Hz, 2H) was assigned to the methylene protons  $\alpha$  to the sulfone.

Scheme 5

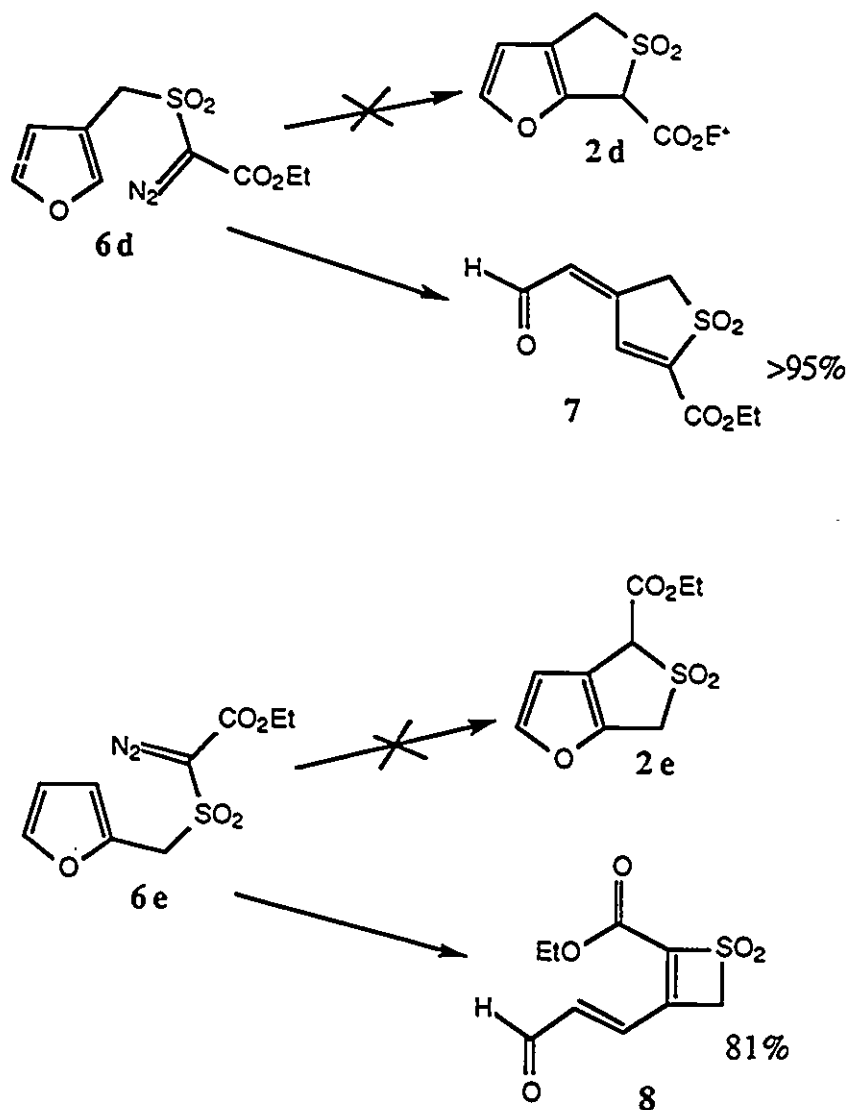

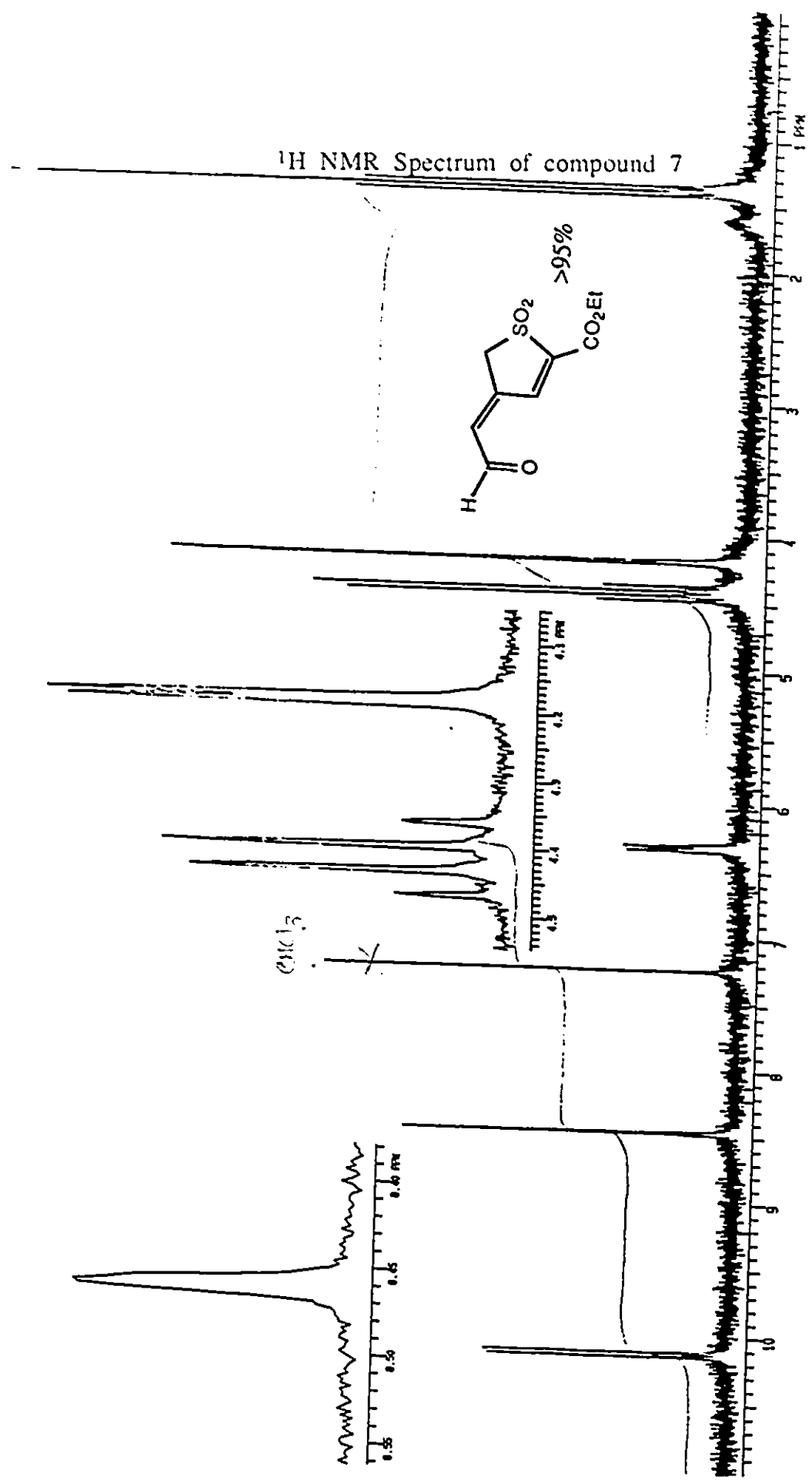

The formation of 7 can be readily rationalized as resulting from either fragmentation of a strained cyclopropane intermediate 9, or more directly from a zwitterion 10, which arose from electrophilic attack of the carbenoid on the furan ring. There are several examples which exist in the literature of ring opening of furans after electrophilic attack by a carbenoid.<sup>8,9,10</sup> (Scheme 6)

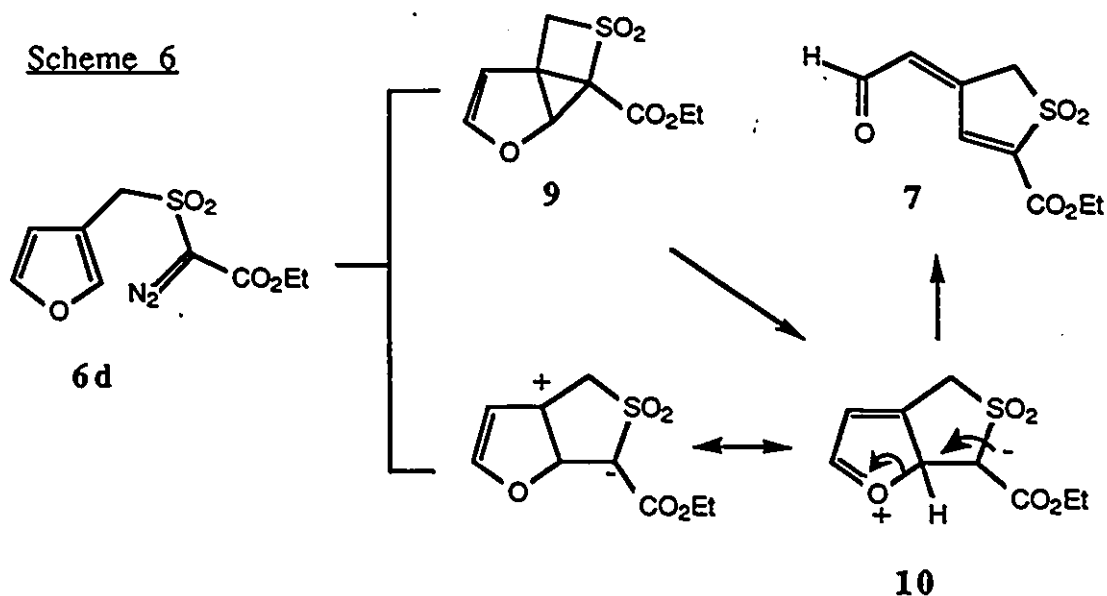

Padwa, Adams, and Wenkert reported similar results when studying the reactions of diazoketones in the presence of furans. Padwa et al<sup>8</sup> obtained the unsaturated aldehyde 13 in 86% yield from the reaction of the diazoketone 11 with rhodium acetate. These authors postulated that the cyclopropane 12 was the intermediate in the conversion of 11 to 13. (Scheme 7)

Scheme 7

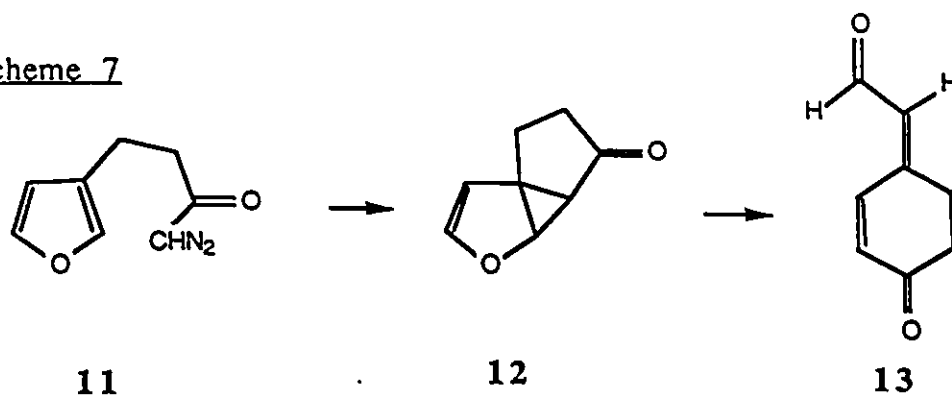

Julian Adams from Merck-Frosst synthesized ( $\pm$ )-HETE from furan and diazoketones via an intermolecular diazo cyclopropanation reaction.<sup>9</sup> He isolated the cyclopropane 16 as an intermediate in the conversion of 15 to a conjugated keto ester 17. (Scheme 8) Wenkert synthesizes<sup>1</sup> (*Z*)-4-oxo- $\beta$ -ionone from a diazoketone using the same approach.<sup>10</sup>

Scheme 8

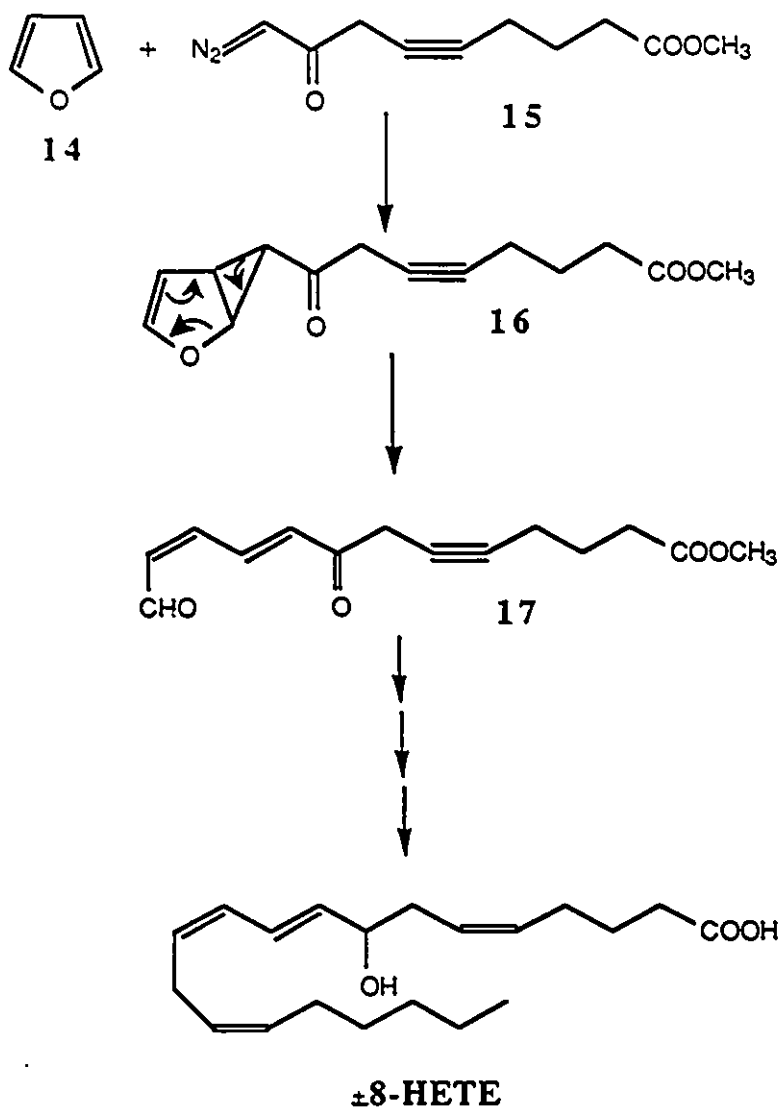

One can similarly speculate that the thiete sulfone 8 was formed either by electrocyclic ring opening of the strained cyclopropane intermediate, or possibly from rearrangement of the zwitterion 10. (Scheme 9)

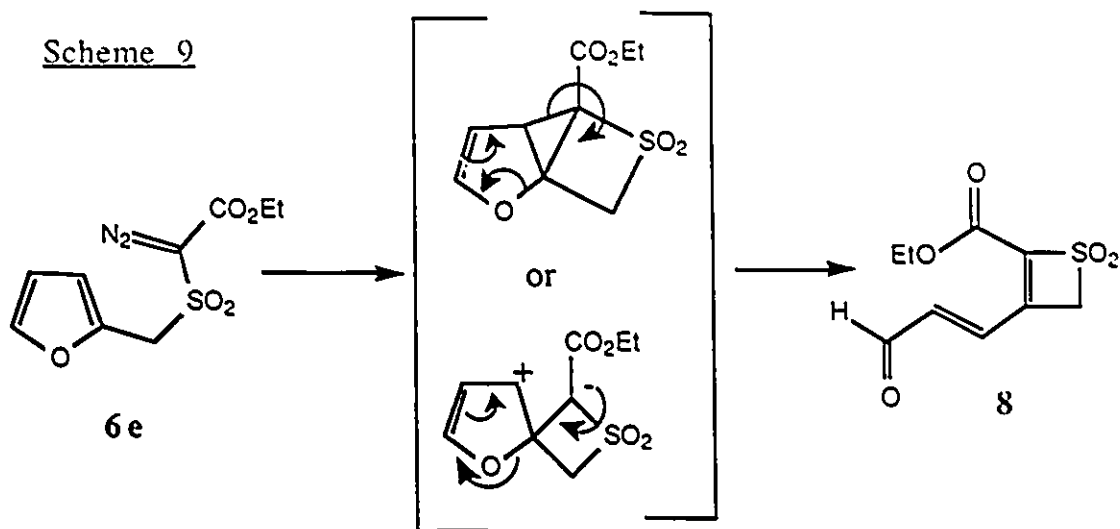

### Preparation of 3-acetyl-2-hydroxyindoles

Finally, it was decided to investigate the reactivity of  $\alpha$ -diazo- $\beta$ -ketoamides such as 23 a-g. In this instance, insertion of the rhodium carbenoids should yield 2-acetyl-3-hydroxyindoles, 24 a-g. M. Hrytsak had already shown that  $\alpha$ -diazo- $\beta$ -ketoesters 18 undergoes rhodium catalyzed carbenoid insertions into aromatic C-H bonds to give 3-acetyl-2-hydroxy-benzofurans 19 in almost quantitative yields.<sup>11</sup> (eqn-1) Initial studies in this area were carried out in collaboration with Nola Etkin as part of her Honours B.Sc. thesis.

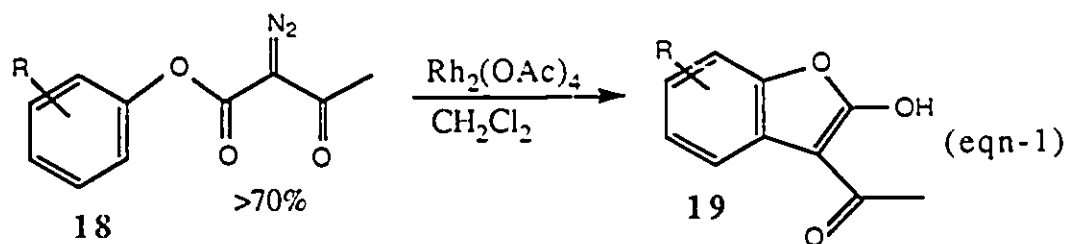

The synthesis of the required  $\alpha$ -diazo- $\beta$ -ketoamides is shown in Scheme 10. The readily available secondary amines **20 a-f** were first converted to  $\beta$ -ketoamides in yields ranging from 90-95% by reaction with diketene in the presence of a catalytic amount of NaOAc. Secondary amines, on treatment with diketene, formed  $\beta$ -ketoamides in the presence of a catalytic amount of NaOAc.  $\beta$ -ketoamides were converted into  $\alpha$ -diazo- $\beta$ -ketoamides **23 a-g** by treatment with tosyl azide and  $\text{NEt}_3$  in very high yields. The reaction was carried out in acetonitrile. Diazo compounds **23 a-g** were prepared from *N*-methylaniline, **20a**, *N*-methyl-2-methyl-4-methoxy-aniline, **20b**, *N*-benzyl-*m*-chloroaniline, **20c**, *N*-phenylaniline, **20d**, tetrahydroquinoline, **20e**, *N*-benzyl-*m*-nitroaniline, **20f**, and aniline, **20g**. These diazo compounds show a characteristic peak at  $2120 \text{ cm}^{-1}$  in their IR spectrum. Other spectroscopic data are recorded in the Experimental Section.

Scheme 10

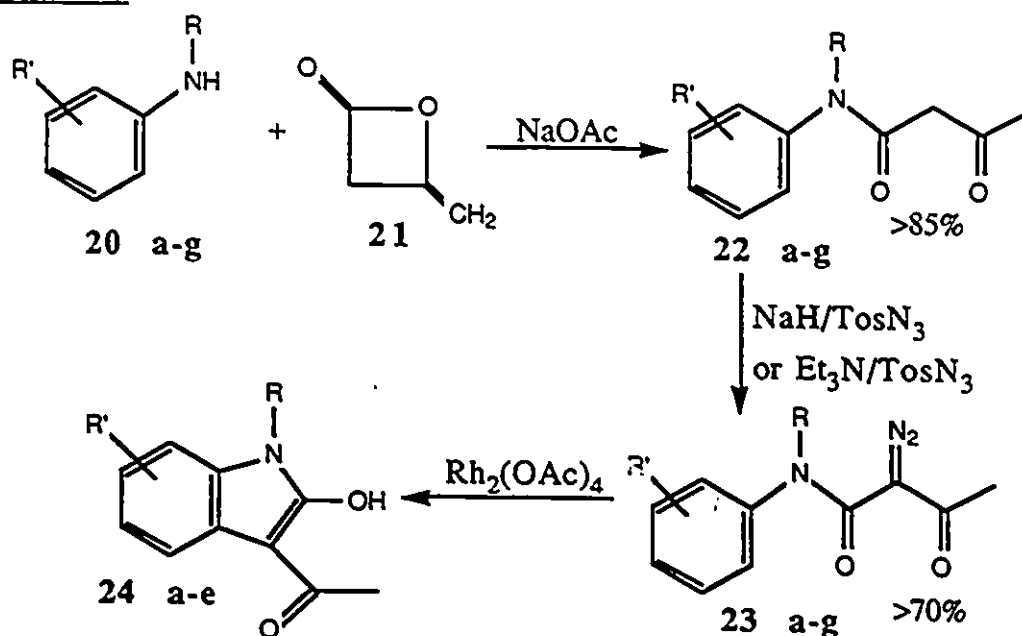

In order to determine the effect of substituents on the carbon next to the diazo group on the aromatic C-H bond diazo insertion reactions, we carried out the synthesis of the diazo compounds 25 and 26, entries 8 and 9 in Table III, from N-methylaniline and tetrahydroquinoline, respectively. N-methylaniline and tetrahydroquinoline, on treatment with malonyl chloride formed malonamides which were converted into the diazo compounds by reaction with tosyl azide and NaH. The overall yield in each of the two step sequences was near 60%. (Scheme 11)

Scheme 11

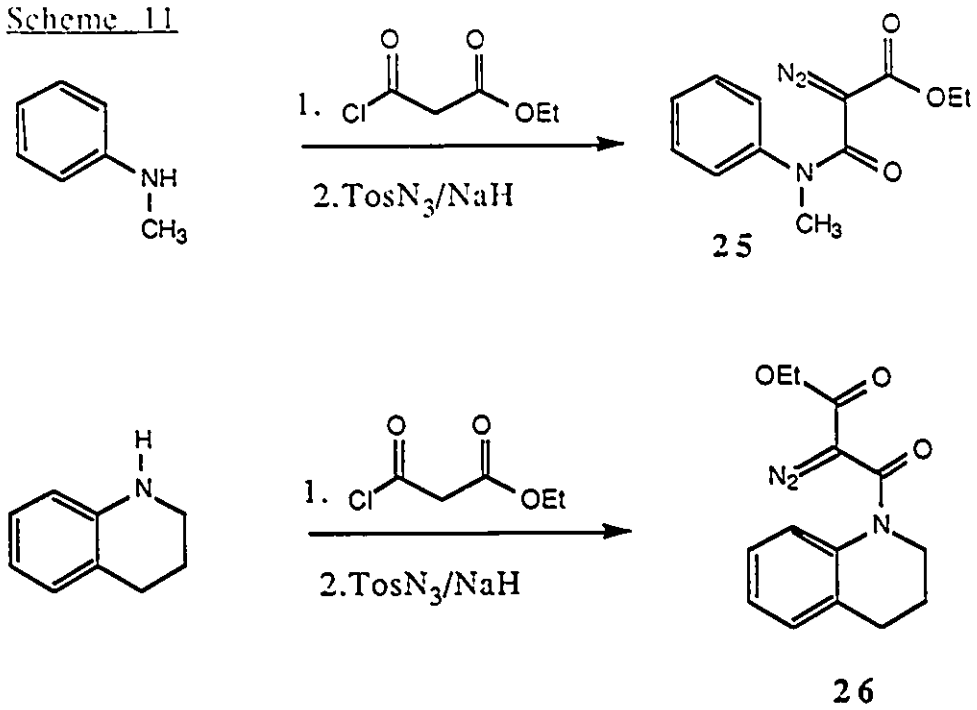

Table III

Entry	Diazo compound	Product	yield %
1			77
2			77
3			>95
4			87
5			42

Table III continued

6			5
7			7
8			12
9		—	—

$^1\text{H}$  NMR Spectrum of compound 24a

<sup>1</sup>H NMR Spectrum of compound 24e

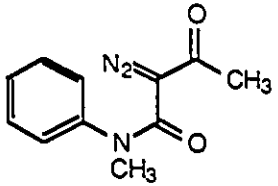
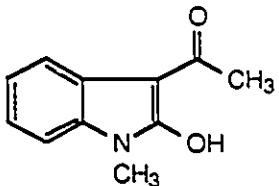
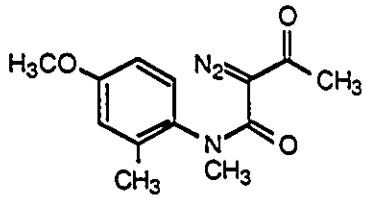
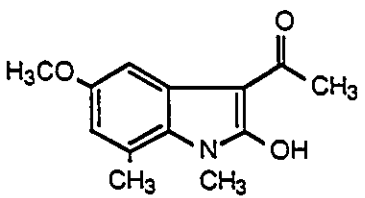
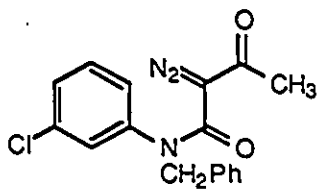
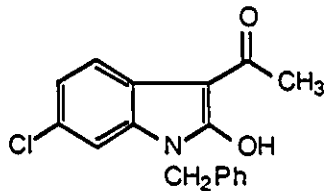
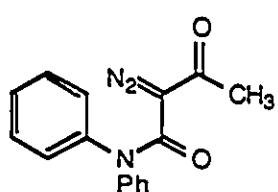
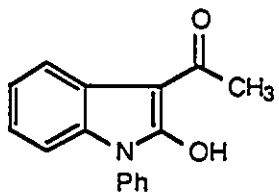
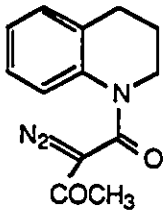
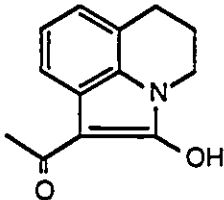
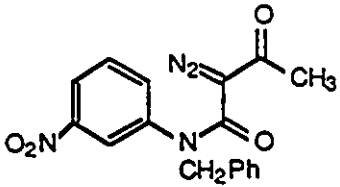
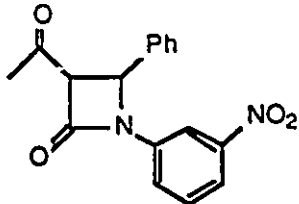
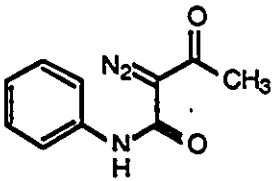
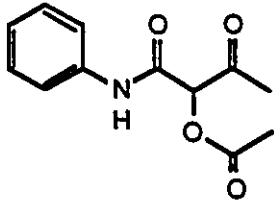
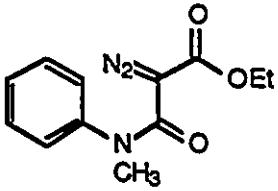
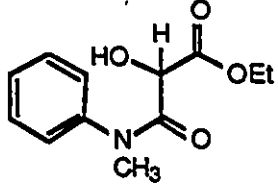
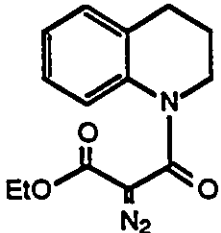
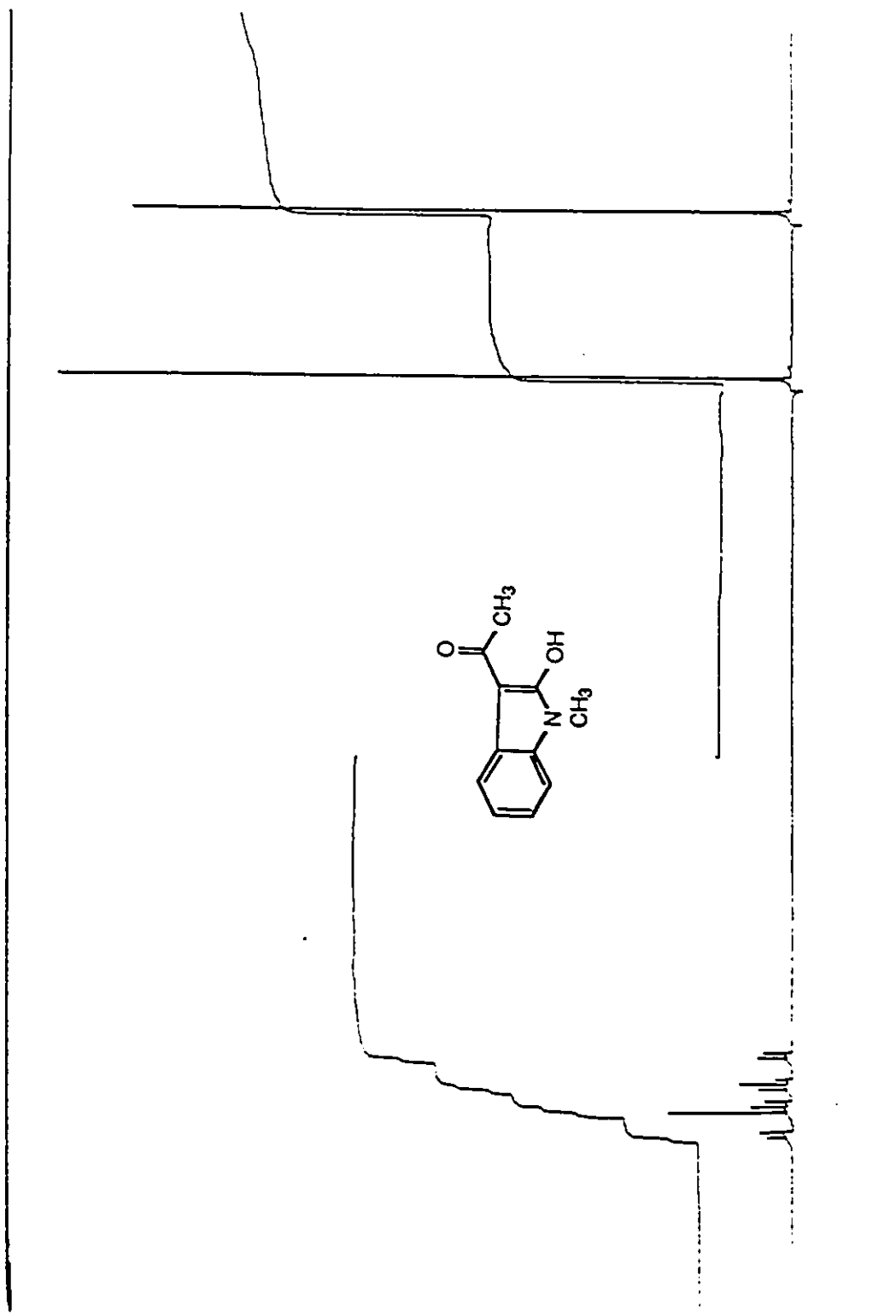
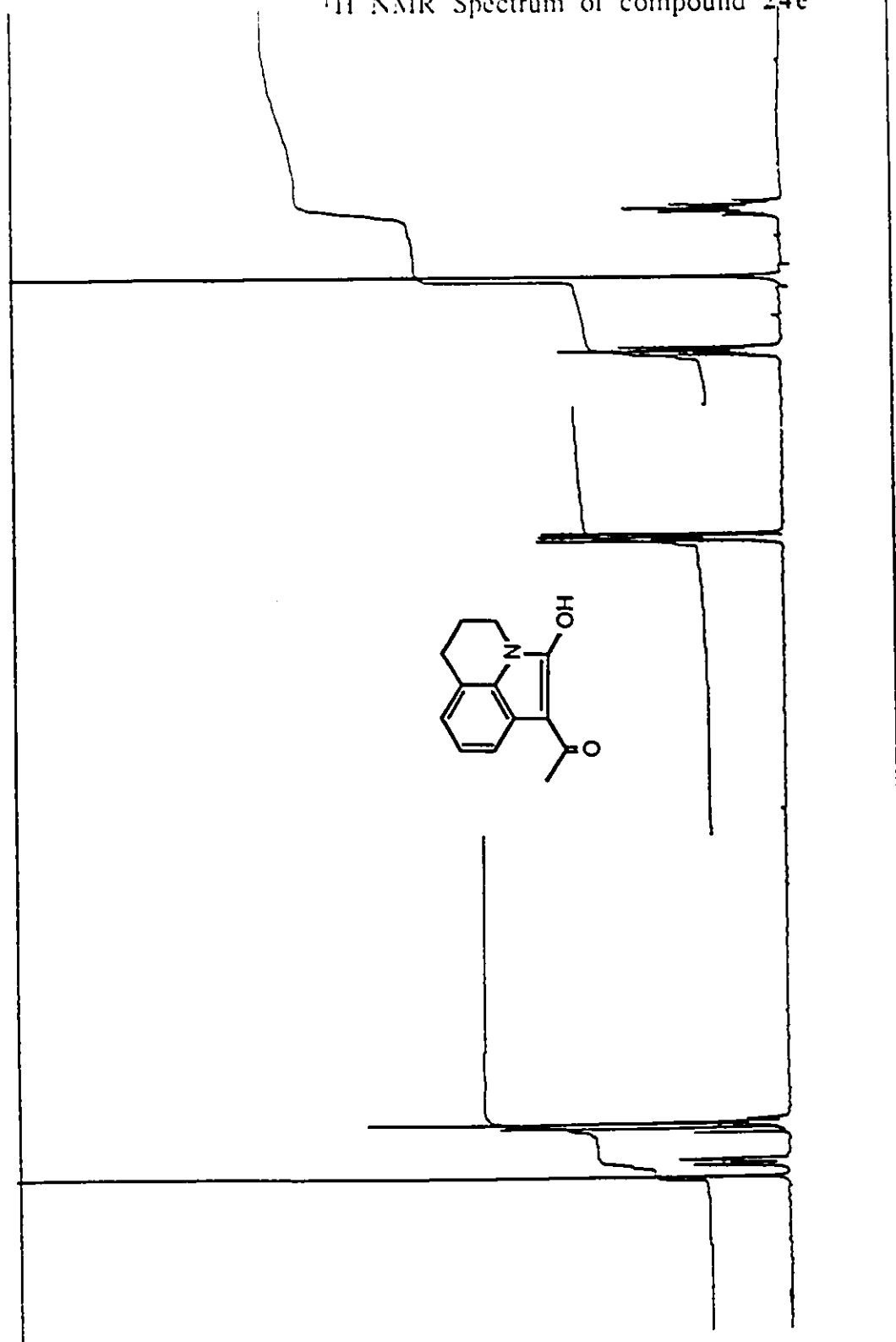
The diazo compounds in Table III formed a variety of products on treatment with catalytic amounts of rhodium acetate in refluxing benzene via a carbenoid insertion reaction. Entries 1-5 in Table III formed the expected aromatic C-H insertion products as depicted in Scheme 9. These products were shown by NMR and IR to exist as 2-hydroxyindole derivatives rather than 2-oxoindole derivatives.

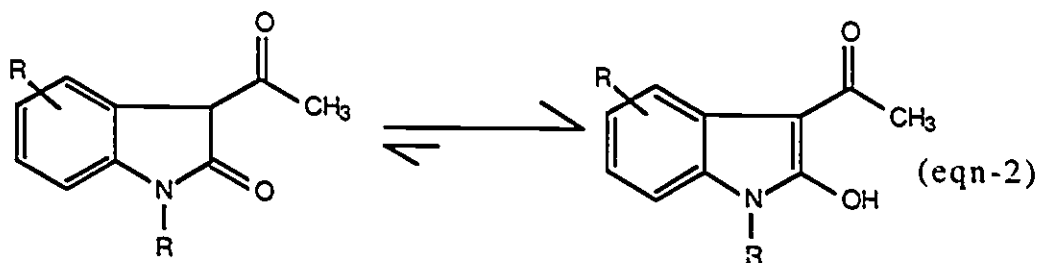

For example, when compound 23a (entry 1 in Table III) was refluxed in benzene in the presence of rhodium acetate as a catalyst 3-acetyl-2-hydroxyindole was formed in 77% isolated yield. The  $^1\text{H}$  NMR of this compound showed two 3H singlets as  $\delta=2.44$  and 3.33 ppm which were assigned to the acetyl and N-methyl groups respectively, and a multiplet due to the remaining 4 protons on the aromatic ring appeared between 6.95-7.36 ppm. In addition, a signal at 13.5 ppm appeared due to the enolic hydrogen present for the 3-hydroxy group of the indole. The IR shows a strong peak at 1650-1660  $\text{cm}^{-1}$  typical of a highly conjugated ketone. The 3-acetyl-2-oxindole structure would have been expected to have both the 5-membered ring amide and the acetyl peak near 1710  $\text{cm}^{-1}$ . Since no peaks were observed in this range, the equilibrium (eqn-2) must strongly favour the hydroxyindole form. In the  $^{13}\text{C}$  NMR spectrum of this compound two peaks were present in the  $\delta=170-173$  and 101-

102 ppm ranges which were ascribed to carbons 2 and 3 of the indole ring respectively.<sup>12</sup> Similar data were found for compounds 24b-e. (See Experimental Section.)

The diazo compound, 23e, (entry 5, Table III) in the presence of rhodium acetate, formed only the aromatic C-H insertion product, 24e, with no traces of the aliphatic insertion product, 27. This observation parallels those of Nakatani and Adams (Chapter 4) who also found that formal aromatic C-H insertion reactions resulting in 6,5 fused ring systems are preferred over insertions into an aliphatic  $\gamma$ -C-H bond. (Scheme 12)

Scheme 12

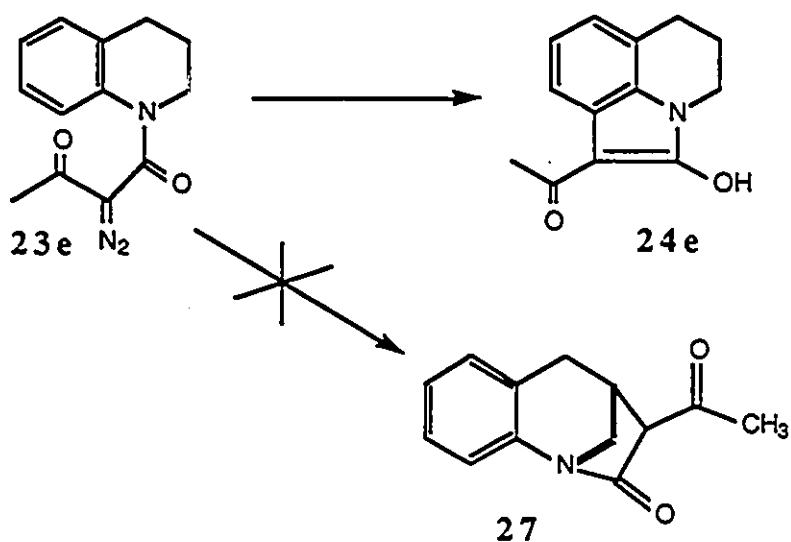

In contrast to the above examples, the rhodium acetate catalyzed reactions of the diazo compounds in entries 6-9 of Table III gave different and much less satisfactory results. These are discussed on an individual basis below. Compound 23f (entry 6 of

Table III) contains the strongly electron-withdrawing nitro group on the aromatic ring. It did not undergo the expected aromatic diazo C-H insertion reaction in the presence of rhodium acetate, but instead underwent an aliphatic C-H bond insertion to give a  $\beta$  lactam, **28** albeit in only 5% isolated yield. This result also confirms that the rhodium carbenoid insertion reactions are electrophilic in nature. (Scheme 13)<sup>13</sup>

Scheme 13

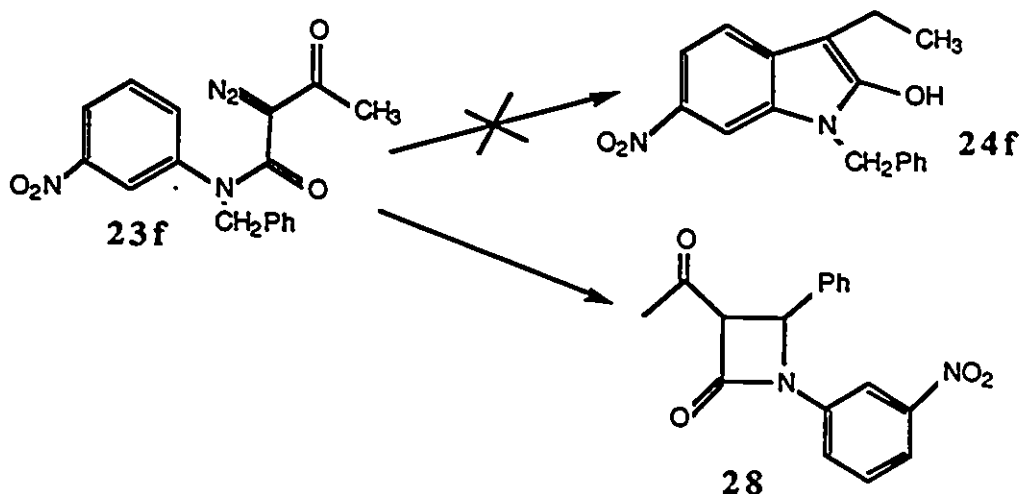

The reaction of diazo compound **23g**, entry 7 in Table III, in methylene chloride at room temperature in the presence of rhodium acetate proceeded quite slowly and afforded a myriad of products (TLC). On purification, **29** was isolated in 7% yield. In  $^1\text{H}$  NMR two singlets at  $\delta = 2.29$  (3H,  $\text{COCH}_3$ ) and 2.45 (3H,  $\text{COCH}_3$ ) and a peak at 5.62 (s, 1H) clearly indicated the structure to be **29**. In the mass spectrum a peak at  $m/e = 235$  ( $\text{M}^+$ , 10) and a base peak at  $m/e = 43$  ( $\text{COCH}_3$ ) further confirmed the assigned structure. This compound may have resulted from displacement of one of the acetate ligands of

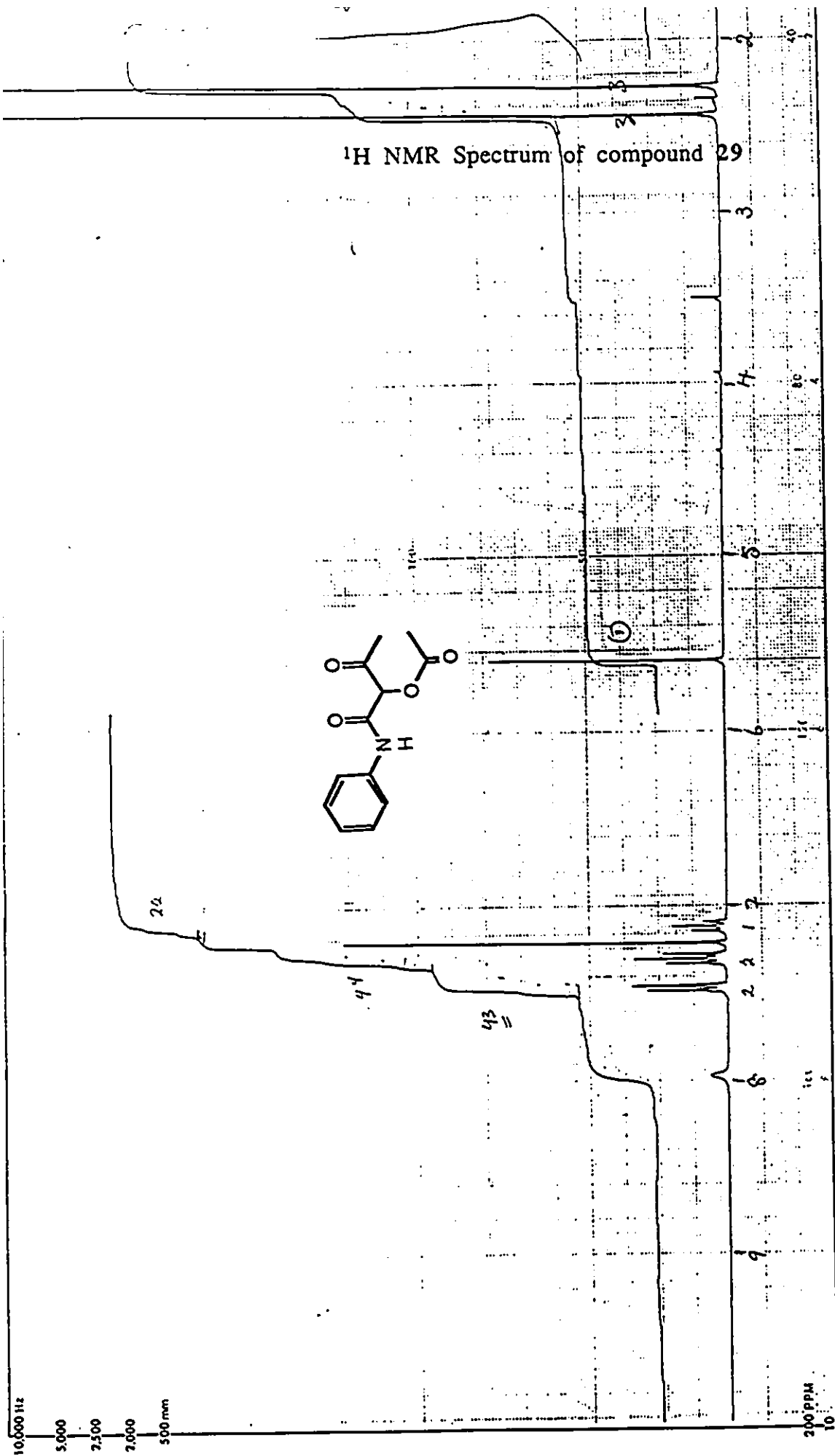
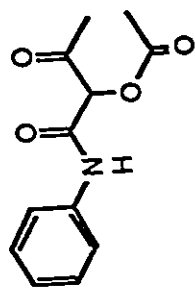
$^1\text{H}$  NMR Spectrum of compound 29

the catalyst by the amide group of 27g. The difference between the diazo compound of entry 1 and entry 7 in Table III is that entry 1 is a tertiary amide and entry 7 is a secondary amide. Surprisingly, by changing from a tertiary amide to a secondary amide the diazo insertion reaction failed. (Scheme 14) No obvious explanation can be advanced to explain the difference in behaviour between 23a and 23g.

Scheme 14

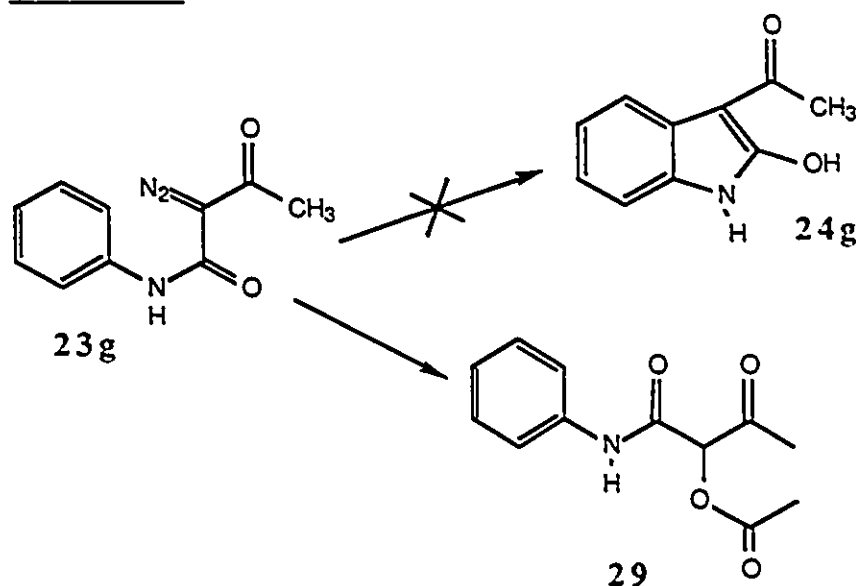

The diazo compound 25, (entry 8 in Table III) bearing an  $\alpha$ -carboethoxy group formed in refluxing benzene in the presence of rhodium acetate a compound in 12% yield which was identified as the alcohol 30. The mass spectrum showed a peak at  $m/e=237$  ( $M^+$ , 10%) with a base peak at 134 ( $M^+-CHOHCOOEt$ ). In  $^1H$  NMR two doublets were present at 3.89 and 4.58 ppm. Upon addition of deuterated water, this doublet disappeared and thus was identified as the proton on the hydroxyl group. The doublet at 4.58 ppm

became a singlet and so was assigned to the methine proton. This product may have formed as a result of trapping of the carbenoid by adventitious water present in the reaction mixture. Compound 26, (entry 9 in Table III) also bearing a carbethoxy group  $\alpha$  to the diazo function formed several unidentifiable compounds when refluxed in benzene in the presence of rhodium acetate. (Scheme 15)

Scheme 15

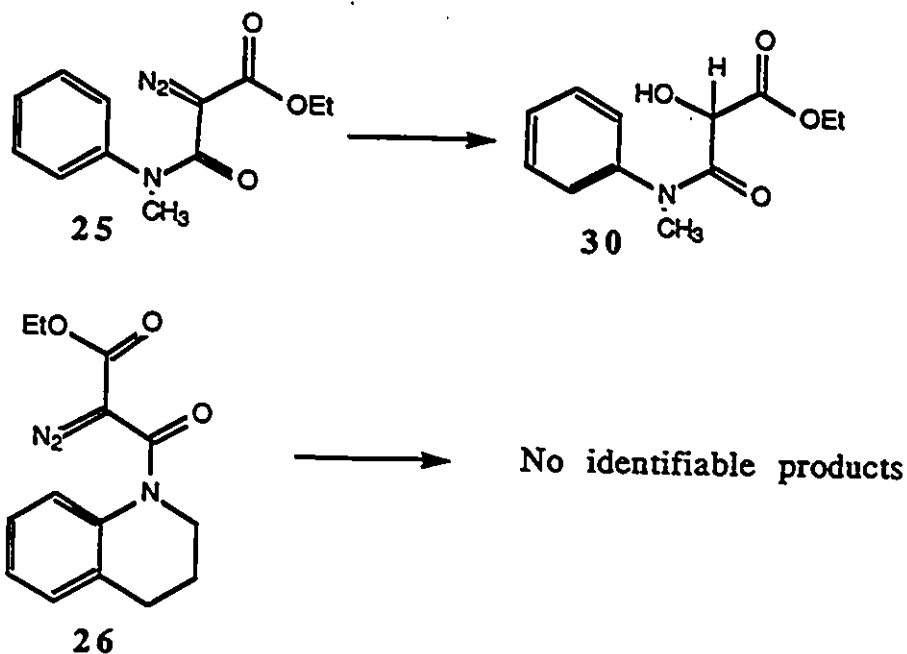

After completing our initial studies as described above, Doyle published three papers in the area of intramolecular insertion reactions of several N-benzyl diazoacetamide derivatives.<sup>13,14,15</sup> N-(benzyl)-N-t-butyl diazoacetamide, 31, on treatment with rhodium acetate in methylene chloride at room temperature, formed azabicyclo [5.3.0] deca-1,4-dien-2-one, 32. This result mirrors those of McKervery et al<sup>16</sup> who showed that 1-diazo-4-phenyl-butan-2-one afforded a cycloheptatriene as the initial isolable product upon

reaction with rhodium acetate. (See also Chapter 4). N-(benzyl)-N-t-butyl-diazoacetamide, **31**, in refluxing benzene gave exclusively a trans  $\beta$ -lactam, **32**, in 98% yield. Rhodium (II) catalyzed decomposition of N(benzyl)-N-ethyl-diazoacetamide in refluxing chloroform produced three products, **37-39**. When N-benzyl-N-methyl-diazoacetamide was treated with rhodium acetate in refluxing benzene a trans  $\beta$ -lactam was formed in only 12% yield.

Scheme 16

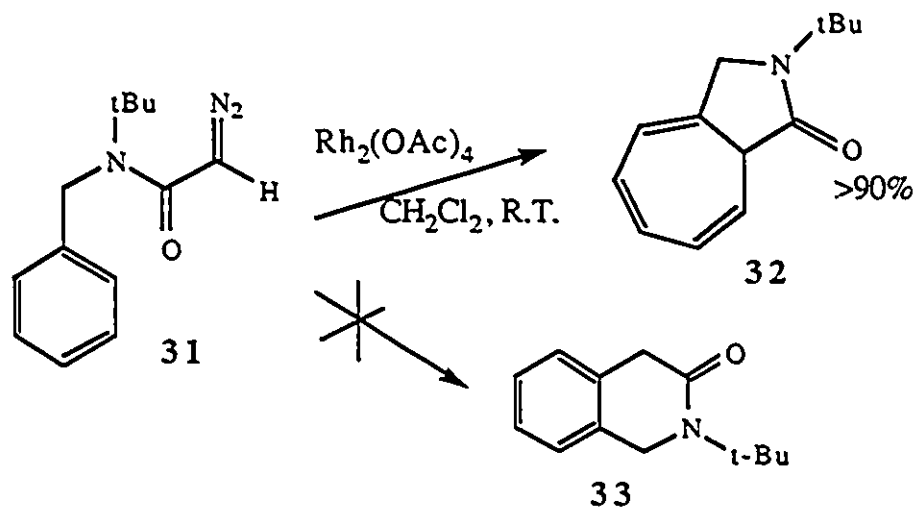

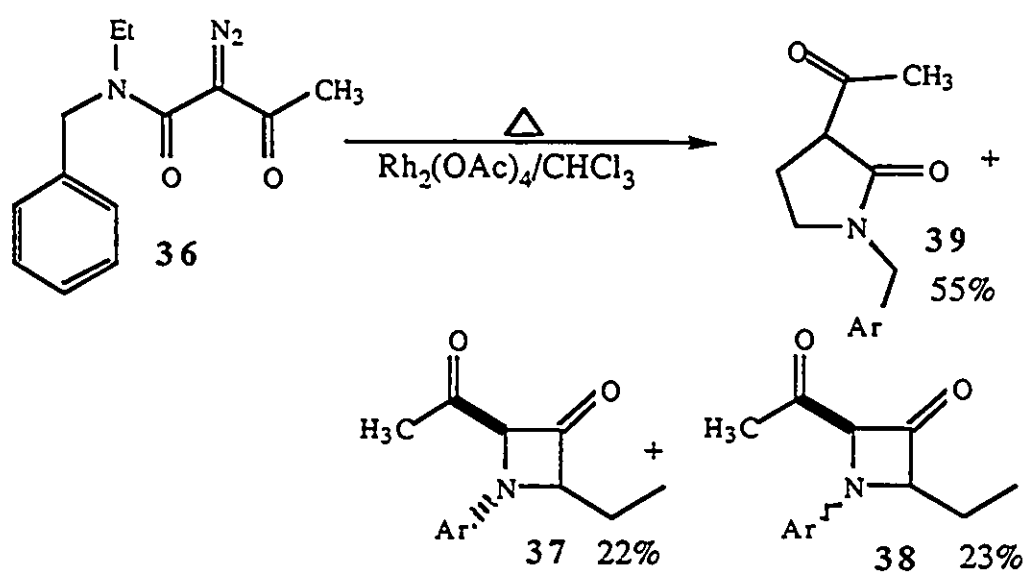
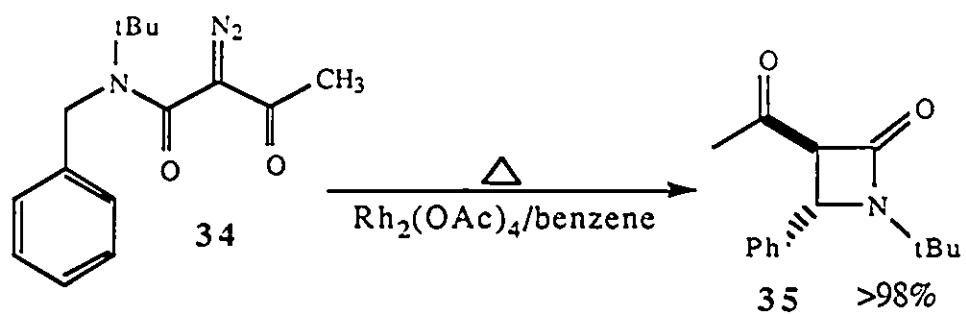

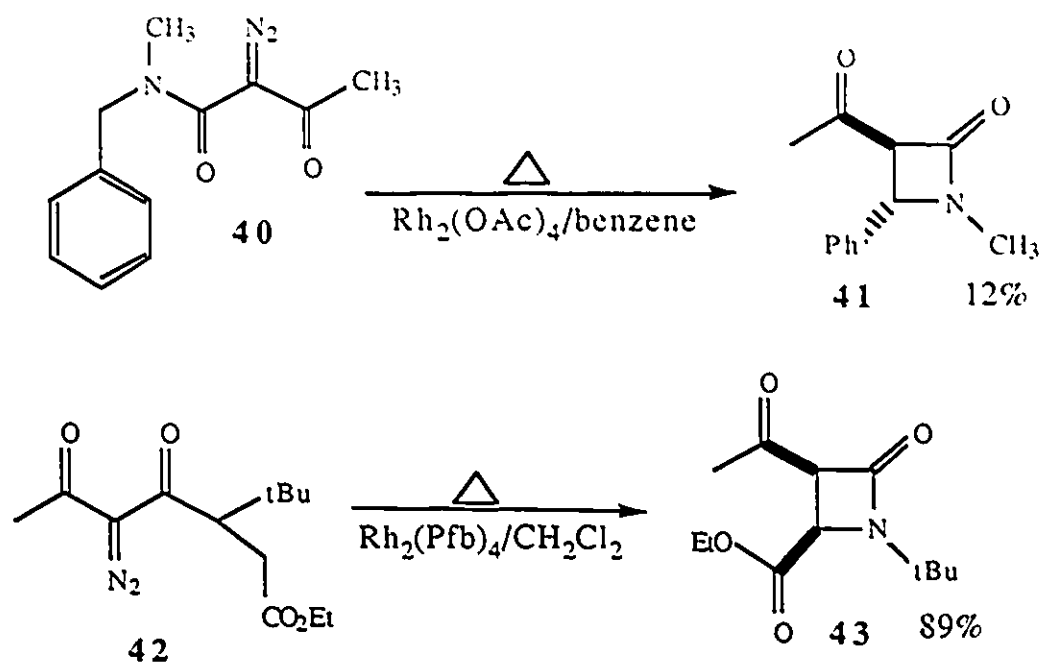

These unusual results can be explained by carbenoid insertion into aliphatic C-H bonds that are locked in close proximity to the reactive carbenoid centre. (See structure 44.)

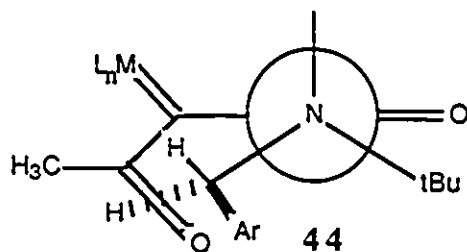

When the size of the group changed from t-butyl to ethyl or methyl, the amount of formation of the  $\beta$ -lactam decreased. This clearly explains there is a conformational bias due to steric factors.

Treatment of the diazoacetamide, **42**, with  $\text{Rh}_2(\text{Pfb})_4$  (rhodium perfluorobutyrate) in methylene chloride resulted in

formation of the *cis*  $\beta$ -lactam, **43**, in 89% yield. The stereochemistry of this  $\beta$ -lactam was opposite to that of **35** and **41**.

Martin Schwartz reported the formation of isoquinolines, **46**, from *N*-benzyldiazoacetamides, **45**, by treatment with anhydrous trifluoroacetic acid in methylene chloride.<sup>16</sup> The formation of **45** presumably involves protonation of the diazo ketone thereby generating a diazonium salt which can undergo electrophilic aromatic substitution with concomitant loss of  $N_2$ .

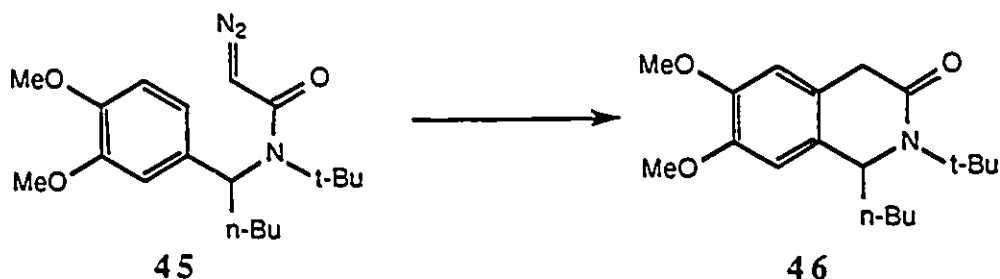

The above results completely contradicted our own results. We never separated any traces of cycloheptatriene or of  $\beta$ -lactam in our reactions, except in the case of compound **28**. All of the diazoacetamides used by Doyle and Schwartz for the rhodium catalyzed diazo insertion reaction contained a tertiary amide, and they did not report any results for diazo insertion reactions involving a secondary diazoacetamide.

In conclusion, sulfone diazo esters underwent an aromatic C-H bond insertion reaction with rhodium acetate in a predictable fashion. By examining tables I and II we can conclude that rhodium carbenoid insertion presents a reliable route 1-carboethoxy-1,3-dihydrobenzothiophene-2,2-dioxides having predictable substitution patterns in the aromatic ring. This method is therefore potentially

valuable for the preparation of substituted aromatic, thiophene and indole xylylenes from simple starting materials. This approach is conceptually different from the existing methodologies and should find several applications for building complex molecules.

Rhodium carbenoids behave as highly electrophilic reagents. The position of attack on these intermediates by the aromatic ring is that which bears the greatest electron density. In competition reactions products resulting from electrophilic aromatic substitution (formal insertion into an aryl C-H bond) completely dominate over  $\gamma$ -aliphatic C-H insertion if the aryl ring is not strongly deactivated (entry 6, Table III) and if the electrophilic substitution reaction results in the annulation of a 5-membered ring.

There are only subtle differences between our diazo compounds and Doyle's. In our case, we obtained aromatic C-H insertion products when we refluxed the diazo compound in benzene in the presence of rhodium acetate. When Doyle refluxed his diazo compounds in benzene in the presence of rhodium acetate as a catalyst he obtained trans  $\beta$ -lactams, 35. By changing catalysts from rhodium acetate to rhodium perfluorobutyrate he obtained cis  $\beta$ -lactams, 43. On the other hand, when he used the diazoacetamide 31 with rhodium acetate at room temperature, he obtained a remarkably different compound, an azabicyclodecatriene, 32. The insertion reaction occurs only with a tertiary amide and fails when it is a secondary amide. When we changed our substrate from one with an acetyl group to one with a carbethoxy group, as in compounds 25 and 26, the reactions failed completely.

In general, the type of substituents present next to the diazo group, the choice of solvent, and the choice of catalyst can markedly alter the course of the reaction. Considerable caution should be exercised when planning a synthetic strategy using these compounds.

The mechanism of rhodium catalyzed carbenoid insertion reactions into aromatic C-H bonds (or aliphatic C-H bonds) is still open to question. In Chapter 4 of this thesis this problem is addressed by analyzing the results of deuterium isotope effects in the aromatic C-H insertion reactions.

## Experimental

### General procedures for the preparation of the benzylic sulfides 4 a-e

To a solution of ethyl mercaptoacetate (1 equiv.) and benzylic alcohol (1 equiv.) in  $\text{CH}_2\text{Cl}_2$  (2 mL/mmole of alcohol) under  $\text{N}_2$  at room temperature was added 0.5 equivalents of powdered zinc iodide. The mixture was stirred for 45 min and then washed with water. The organic phase was dried over  $\text{MgSO}_4$  and evaporated to give the crude benzylic sulfide in 85-95% yield. The crude sulfides were identified by their nmr spectra. The key features were the methylene group  $\alpha$  to the aromatic ring found in the  $\delta = 3.7\text{-}3.9$  ppm range and the methylene group  $\alpha$  to the ester at  $\delta = 2.9\text{-}3.1$  ppm. They were used for the next step without further purification and chracterization.

### Oxidation of benzylic sulfides to the corresponding sulfones 5 a-e

#### General procedure

A solution of sulfide in  $\text{CH}_2\text{Cl}_2$  (2 mL/ mmole) was cooled in an ice bath, and m-chloroperoxybenzoic acid (2 equiv) was added in small portions. The mixture was stirred at  $0^\circ\text{C}$  for 45 minutes following the addition of the peracid; TLC analysis revealed that all of the starting sulfide had been consumed. The mixture was filtered to remove the m-chlorobenzoic acid by-product, and the filtrate was successively washed with 10%  $\text{Na}_2\text{SO}_3$  then 5%  $\text{NaHCO}_3$  solutions and then dried over  $\text{MgSO}_4$  and evaporated to give the crude sulfones.

These were purified by silica gel chromatography. Data concerning individual sulfones are tabulated on the following page.

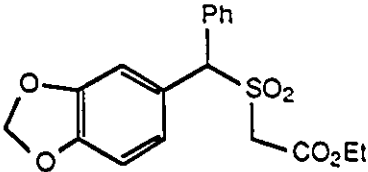
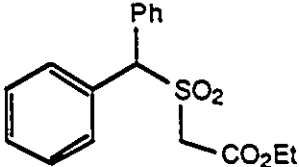
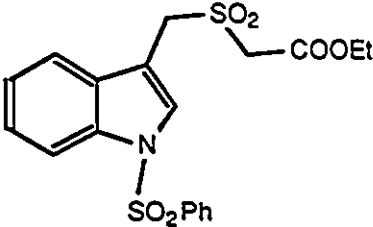
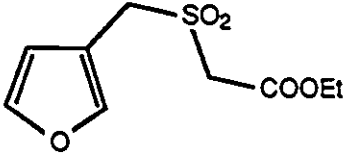
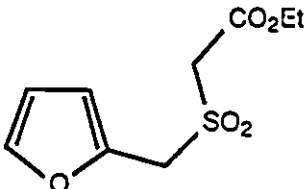
Entry	Diazo Compound	Yield %	mp	<sup>1</sup> HNMR
1		76	oil	1.33 (t, 3H), 3.87 (s, 2H) 4.23 (q, 2H), 6.00 (m, 3H) 7.30 (t, 8H)
2		73	oil	1.33 (t, 3H), 3.80 (s, 2H) 4.26 (q, 2H), 5.93 (s, 1H) 7.40 (m, 10H)
3		72	93	1.33 (t, 3H), 4.00 (s, 2H) 4.23 (q, 2H), 4.85 (m, 3H) 7.50 (m, 10H)
4		21	oil	1.33 (t, 3H), 3.73 (s, 2H) 4.16 (q, 2H), 4.26 (s, 2H) 6.40(s, 1H), 7.33 (d, 2H)
5		40	oil	1.33 (t, 3H), 4.00 (s, 2H) 4.26 (q, 1H), 4.63 (s, 2H) 6.50 (b, 2H), 7.50 (s, 1H)

General procedure for the preparation of the Diazo Sulfones 6 a-e

Sodium hydride was washed twice with hexanes at  $-78^{\circ}\text{C}$  under nitrogen atmosphere. A solution of sulfone (3 mL/mmol) in dry THF and tosyl azide were added sequentially at  $-78^{\circ}\text{C}$ . The reaction mixture was allowed to warm to room temperature. Stirring was maintained at room temperature for 3-5 minutes and then the reaction mixture was quenched with saturated  $\text{NH}_4\text{Cl}$  solution, extracted with ether, dried and evaporated. The crude diazo compound thus obtained was further purified by chromatography on silica gel using 3:1 hexane:ethyl acetate as the eluant. Data concerning individual diazo sulfones are tabulated on the next page. In addition, the characteristic signal for the diazo group appeared at  $2120\text{ cm}^{-1}$  in the IR spectrum.

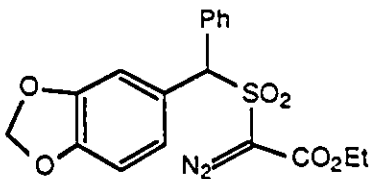
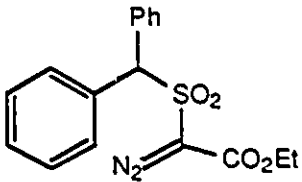
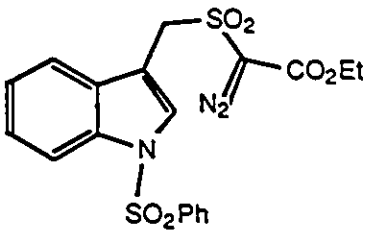
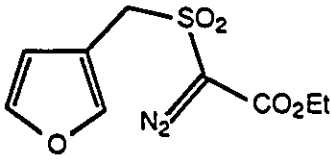
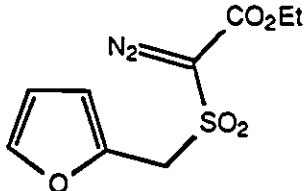
Entry	Diazo Compound	Yield	mp	<sup>1</sup> H NMR
1		27	oil	1.30 (t, 3H), 4.30(q, 2H) 6.00 (m, 3H), 7.3(m, 8H)
2		26	oil	1.30 (t, 3H), 4.33(q, 2H) 6.10(s,1H), 7.35(m, 10H)
3		33	oil	1.30 (t, 3H), 4.33(q, 2H) 4.73 (s, 2H), 7.60(m, 10H)
4.		41	oil	1.33 (t, 3H), 4.40(q, 2H) 4.50 (s, 2H), 6.50(s, 1H) 7.56m, 2H)
5.		43	oil	1.33 (t, 3H), 4.20(q, 2H) 4.56 (s, 2H), 6.33(s, 2H) 7.33 (s,1H)

Rhodium carboxylate catalyzed cyclizations of the  $\alpha$ -diazosulfones.

General procedure.

A solution of the diazo sulfone in dry  $\text{CH}_2\text{Cl}_2$  (4 mL/mmol) was stirred at room temperature and treated with 5 mole % of rhodium acetate or rhodium trifluoroacetate in one portion. Gas evolution occurred slowly. The progress of the reaction was monitored by TLC. When the reaction was judged to be complete, the green solution was filtered through a cotton plug and the solvent was evaporated. The desired bicyclic sulfones were purified via silica gel chromatography. Data concerning individual bicyclic sulfones are listed below.

**2a:** 52%\*; mp 74°C;  $^1\text{H}$  NMR ( $\text{CDCl}_3$ )  $\delta$  7.35(m, 5H), 6.86(s) and 6.81(s); 1H total, 6.50 (s) and 6.49(s); 1H total, 6.0(d, 2H,  $J=7.6$  Hz), 5.64(s) and 5.43(s); 1H total, 5.12(s) and 5.08(s); 1H total, 4.31(m, 2H), 1.33(m, 3H); IR (neat)  $\text{cm}^{-1}$  3050, 2980, 1740, 1330, 1270; ei-MS  $m/e$  360( $\text{M}^+$ , 1%), 296( $\text{M}^+-64$ , 11%), 223( $\text{M}^+-137$ , 100%); A HR-MS for a peak at  $m/e = 296(\text{M}^+-\text{SO}_2)$  gave 296.1047, calculated for  $\text{C}_{18}\text{H}_{16}\text{O}_4 = 296.1048$ .

\* Use of rhodium trifluoroacetate instead of rhodium acetate as a catalyst in the diazo insertion reaction increased the yield of cyclization product from 52% to 74%.

**2b:** 47%; mp 42°C;  $^1\text{H}$  NMR ( $\text{CDCl}_3$ )  $\delta$  7.37(m, 8H), 7.10(m, 1H), 5.78(s) and 5.55(s); 1H total, 5.23(s) and 5.19(s); 1H total, 4.33(m, 2H), 1.31(m, 3H); IR (neat)  $\text{cm}^{-1}$  3050, 2980, 1740, 1330, 1270, 1170; ei-MS  $m/e$  252( $\text{M}^+-64$ , 14%), 179( $\text{M}^+-137$ , 100%); A HR-MS for a peak

at  $m/e = 252(M^+ - SO_2)$  gave 252.1157, calculated for  $C_{17}H_{16}O_2 = 252.1150$ .

2c: 26%; mp 245°C;  $^1H$  NMR ( $CDCl_3$ )  $\delta$  8.01(dd, 2H,  $J=8.3, 1.3$ ), 7.86(dd, 1H,  $J=0.8, 8.4$ ), 7.52(m, 5H), 7.15(ddd, 1H,  $J=7.6, 7.6, 0.8$ ), 6.59(d, 1H,  $J=3.3$ ), 4.76(d, 1H,  $J=7.4$ ), 4.49(m, 2H), 1.44(s, 3H); IR (neat)  $cm^{-1}$  3050, 2980, 1740; ei-MS  $m/e$  419( $M^+$ , 3.2%), 355( $M^+ - 64$ , 31%), 278( $M^+ - 141$ , 76%), 77( $M^+ - 342$ , 100%); A HR-MS for a peak at  $m/e = 278(M^+ - SO_2Ph)$  gave 278.0461, calculated for  $C_{13}H_{12}NO_4S = 278.0476$ .

Reaction of the furan substituted diazo compounds with rhodium acetate.

A solution of the diazosulfone 6d (260 mg, 1 mmol) in 10 mL of dry  $CH_2Cl_2$  was stirred with  $Rh(OAc)_4$  for 1 h. TLC analysis showed the disappearance of starting material and the formation of one major product. The reaction mixture was filtered through a cotton plug and the solvent was evaporated to afford 230 mg (>98%) of crude unsaturated aldehyde 7.  $^1HNMR$ : (200 MHz)  $\delta=1.40$  (t,  $J=7$  Hz, 3H), 4.24 (d,  $J = 1.3$  Hz, 1H), 4.43 (q,  $J=7$  Hz, 2H) 6.37 (dd,  $J=6, 1.3$  Hz, 1H), 8.50 (s, 1H), 10.16 (d,  $J=6$  Hz, 1H) ppm. Attempted chromatography on silica gel led to decomposition. The ei-MS of 7 failed to show a molecular ion peak at  $m/e = 230$ . The highest  $m/e$  peak occurred at  $M^+ - OC_2H_5 = 185$ . A HR-MS of this peak gave 184.9943, calculated for  $C_7H_5O_4S = 185.0092$ .

The diazo sulfone 6e (0.18 g, 0.7 mmol) was treated as described above for compound 7 with 20 mg of rhodium acetate. The

crude product, 130 mg (81%) of **8** as a colorless oil, had  $^1\text{H}$ NMR (200 MHz) peaks at  $\delta$ =1.31 (t,  $J$ =7 Hz, 3H), 4.30 (q,  $J$ =7 Hz, 2H), 4.81 (s, 2H), 6.45 (dd,  $J$ =12 Hz, 6.3 Hz, 1H), 7.68 (d,  $J$ =12 Hz, 1H) and 10.16 (d,  $J$ =6.3 Hz, 1H) ppm. Attempted further purification via silica gel column chromatography resulted in extensive decomposition. A HR-MS for a peak at  $m/e = 185(\text{M}^+-\text{O}c2\text{H}5)$  gave 184.9932, calculated for  $\text{C}_7\text{H}_5\text{O}_4\text{S} = 185.0092$ .

#### General procedure for the Preparation of $\beta$ -Keto Amides **22 a-g**

The anilines were mixed with 1.1 equivalents of diketene and 10-20 mg of sodium acetate. The reaction mixture was then refluxed, either neat or as an acetone solution (1mL/mequiv). These reactions could also be carried out in  $\text{CH}_2\text{Cl}_2$  solution (1mL/1mequiv) at  $-20^\circ\text{C}$  by using several drops of triethylamine as catalyst. The crude products were obtained after removal of volatile materials on the rotary evaporator. The yields of the products were generally above 95%, except when aniline was used as the starting amine.(66%) The products were typically a mixture of ketone ( $\delta$  for  $\text{CH}_3\text{CO} = 2.0$  ppm) and enol ( $\delta$  for  $\text{CH}_3\text{C}(\text{OH})=\text{C}=1.7$  ppm) tautomers, with the former predominating by about a 3:1 ratio. These intermediates were not further characterized but converted into the corresponding diazo compounds **23 a-g**.

General procedure for the preparation of  $\alpha$ -Diazo- $\beta$ -Keto-Amides 23  
a-g, 25, 26

Method(A)

To a solution of keto anilide (2-7 mmol) and 2 equiv of triethylamine dissolved in 10 mL of acetonitrile was added 1.1 equiv of tosyl azide. The solution was stirred for 6 h. The residue was evaporated (bath temperature  $< 35^{\circ}\text{C}$ ). The residue was dissolved in ether and washed successively with 10% NaOH solution and then  $\text{H}_2\text{O}$ . The crude  $\alpha$ -diazo- $\beta$ -keto anilides thus obtained was further purified by chromatography on silica gel using hexane:ethyl acetate as the eluant. These compounds were characterized by their simple proton NMR spectra, MS, and mp, and then were reacted directly with rhodium acetate. Data concerning individual  $\alpha$ -diazo- $\beta$ -keto-anilides are tabulated.

Method (B)

Sodium hydride was washed twice with hexanes at  $-78^{\circ}\text{C}$  under nitrogen atmosphere. A solution of malonic ester derivative (3 mL/mmol) in dry THF and tosyl azide were added sequentially at  $-78^{\circ}\text{C}$ . The reaction mixture was allowed to warm to room temperature. Stirring was maintained at room temperature for 3-5 minutes and then the reaction mixture was quenched with saturated  $\text{NH}_4\text{Cl}$  solution, extracted with ether, dried and evaporated. The crude diazo compound thus obtained was further purified by chromatography on silica gel using 3:1 hexane:ethyl acetate as the eluant. Data concerning individual  $\alpha$ -diazo- $\beta$ -keto-anilides are

tabulated. In addition, the characteristic signal for the diazo group appeared at  $2120\text{ cm}^{-1}$  in the IR spectrum.

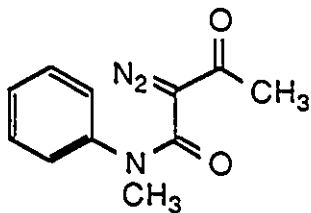
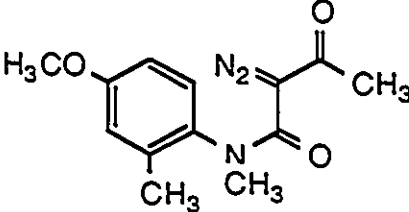
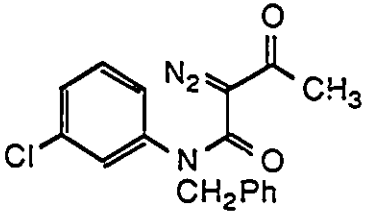
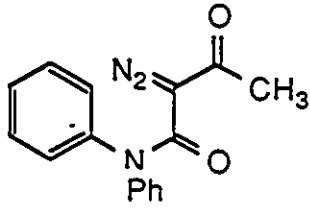
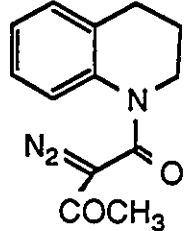
Entry	Diazo compound	yield %	method	mp	<sup>1</sup> HNMR
1		86	A	oil	2.48 (s, 3H), 3.3(s,3H) 7.0-7.5 (m, 5H)
2		84	A	81	2.20 (s, 3H), 2.40(s,3H) 3.17 (s, 3H), 3.78(s, 3H) 7.0-7.5 (m, 5H)
3		>95	A	oil	2.20 (s, 3H), 2.40(s,3H) 3.17 (s,3H), 3.78(s, 3H) 7.0-7.5 (m, 5H)
4		52	A	94	2.50 (s, 3H), 7.0-7.5 (m, 10H)
5		87	A	61	1.80-2.1 (m, 2H), 2.39(s,3H), 2.67 (t, 3H) 3.73(s, 3H), 7.1(s, 4H)

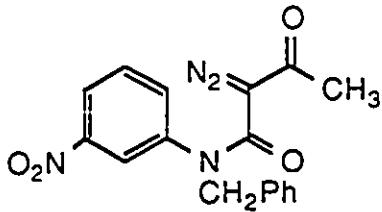
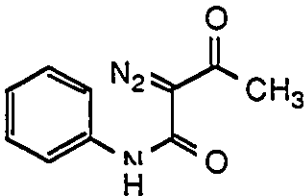
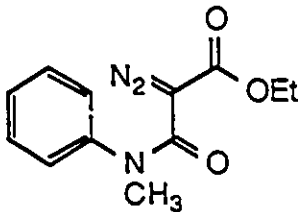
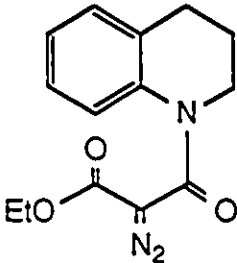
Entry	Diazo compound	yield %	method	mp	<sup>1</sup> HNMR
6		57	A		oil 2.43 (s, 3H), 5.01(s, 2H); 7.18-7.29 (m, 5H) 7.37 (m,1H), 7.51(s, 1H) 7.94 (t,1H), 8.12(m, 1H)
7		76	B		oil 2.36 (s, 3H), 7.30(s, 3H) 10.13(br NH)
8		60	B		oil 1.13 (s, 3H), 3.40(s, 3H) 4.03 (q, 2H), 7.0-7.5 (m, 5H)
9		60	B		oil 1.06 (t, 3H), 1.96(q, 2H); 2.76 (t, 2H), 3.83(m,4H); 7.06 (b, 4H)

Rhodium Acetate Catalyzed Insertion Reactions of the Diazo  
Compounds General Procedure.

The  $\alpha$ -diazo- $\beta$ -keto amides (200 mg) were dissolved in 10-20 mL of benzene. The solution was boiled until approximately half the solvent had evaporated in order to remove any water as an azeotrope. Rhodium acetate (5 mol %) was then added and the solution was refluxed under  $N_2$  for 1-5 h. The crude 3-acetyl-2-hydroxyindoles were purified by flash chromatography. Data concerning individual 3-acetyl-2-hydroxyindoles are listed below.

**24a:** 77%; mp 107-108°C;  $^1H$  NMR ( $CDCl_3$ )  $\delta$  2.44(s, 3H), 3.33(s, 3H), 6.94(d, 1H), 7.09(t, 1H), 7.21(d, 1H), 7.36(d, 1H);  $^{13}C$  NMR  $\delta$  20.3, 25.6, 101.8, 119.6, 122.1, 122.2, 125.2, 138.8, 171.0, 172.8; HR-MS  $M^+$  calcd 189.0788, found 189.0785. Anal. Calcd for  $C_{11}H_{11}NO_2$ : C, 66.94; H, 6.48, N, 6.00. Found: C, 66.77; H, 6.39; N, 6.13.

**24b:** 77%; mp 140-141°C;  $^1H$  NMR ( $CDCl_3$ )  $\delta$  2.41(s, 3H), 2.57(s, 3H), 3.57(s, 3H), 3.79(s, 3H), 6.49(d, 1H,  $J = 2.5$  Hz), 6.78(d, 1H,  $J = 2.5$  Hz),  $^{13}C$  NMR  $\delta$  19.3, 20.4, 28.9, 55.7, 101.7, 104.4, 113.6, 120.7, 123.8, 130.8, 154.9, 171.1, 173.0; HR-MS  $M^+$  calcd 233.1050, found 233.1031.

**24c:** >95% crude; 136.5-137°C, from  $CH_2Cl_2$ -hexane;  $^1H$  NMR ( $CDCl_3$ )  $\delta$  2.05(s, 3H), 4.58(s, 2H), 6.34(s, 1H), 6.55(d, 1H,  $J = 8.0$  Hz), 6.8-6.9(m, 6H);  $^{13}C$  NMR  $\delta$  21.2, 43.1, 100.7, 109.6, 120.2, 121.4, 121.9, 127.1, 127.7, 128.9, 130.2, 135.7, 138.5, 170.8, 175.3; HR-MS  $M^+$  calcd 299.0713, found 299.0697.

24d: 87%; mp 106-107°C;  $^1\text{H}$  NMR ( $\text{CDCl}_3$ )  $\delta$  2.51(s, 3H), 6.9-7.5(m, 9H),  $^{13}\text{C}$  NMR  $\delta$  20.7, 101.6, 109.7, 119.8, 122.2, 122.5, 125.1, 126.6, 128.0, 129.5, 133.9, 138.6, 170.5, 173.9; HR-MS  $\text{M}^+$  calcd 251.0945, found 251.0957.

24e: 42%; mp 158-155°C,  $^1\text{H}$  NMR ( $\text{CDCl}_3$ )  $\delta$  2.05(quint, 2H, J=6 HZ), 2.42(s, 3H.), 2.82(t, 2H, J=6 Hz), 3.82(t, 2H, J= 6 Hz), 6.9-7.2(m, 3H.),  $^{13}\text{C}$  NMR  $\delta$  20.2, 21.4, 24.7, 38.5, 102.5, 117.4, 120.3, 120.6, 121.5, 123.7, 134.8, 169.7, 172.6, HR-MS  $\text{M}^+$  calcd 215.0945, found 215.0932.

#### Reaction of 23f with $\text{Rh}_2\text{OAc}_4$ .

Diazo compound 23f (210 mg) was dissolved in 10 mL of freshly distilled benzene. The solution was brought to reflux and  $\text{Rh}_2\text{OAc}_4$  (12 mg) was added. The solution was refluxed until TLC showed no remaining starting material (1 h). The reaction mixture was filtered, evaporated, and chromatographed on silica gel. Elution with 3:5 hexane:ethyl acetate afforded 4.5 mg of a fraction tentatively identified as 28.

$^1\text{H}$  NMR ( $\text{CDCl}_3$ )  $\delta$  2.39(s, 3H), 4.22(d, 1H, J= 2.7 Hz), 5.52(d, 1H, J= 2.7 Hz), 7.35-7.40(m, 6H), 7.55(d of m, 1H, J= 8.2 Hz), 7.90(d of m, 1H, J= 8.2 Hz), 8.06(t, 1H, J= H). No other pure products were obtained.

#### Reaction of 23g with $\text{Rh}_2\text{OAc}_4$ .

Compound 23g (150 mg) was dissolved in 20 mL of benzene. Approximately 7 mL of solvent were removed via distillation and

then 30 mg of  $\text{Rh}_2\text{OAc}_2$  (~10 mol%) was added. The reaction mixture was refluxed for 2 h. The crude product was separated by chromatatron using 4:1 hexane:ethyl acetate. The yield of compound 29 was 12 mg (7%).

$^1\text{H}$  NMR ( $\text{CDCl}_3$ )  $\delta$  2.29(s, 3H), 2.45(s, 3H), 5.62(s, 1H), 7.15(d, 1H,  $J=7.5$  Hz), 7.33(t, 2H,  $J=7.5$  Hz), 7.49(t, 2H,  $J=7.5$  Hz), 7.95(NH); ei-MS  $m/e$  235( $\text{M}^+$ , 10%), 193( $\text{M}^+-42$ , 31%), 151( $\text{M}^+-84$ , 53%), 43( $\text{M}^+-192$ , 100%); HR-MS calcd 235.08449, found 235.0854.

#### Reaction of 23h with $\text{Rh}_2\text{OAc}_2$ .

A 20 mL solution of benzene containing 140 mg of 23h was heated until approximately 7 mL had distilled off.  $\text{Rh}_2\text{OAc}_2$  (approximately 15 mg) was added and the solution was refluxed for 6 h. The crude product obtained after evaporation of the solvent was purified by passing it twice through a chromatatron silica gel plate, using first 4:1 hexane:ethyl acetate and then 10:1  $\text{CH}_2\text{Cl}_2$ :hexane. The yield of 30 was 16 mg (12%).

$^1\text{H}$  NMR ( $\text{CDCl}_3$ )  $\delta$  1.19(t, 3H,  $J=7.1$  Hz), 3.34(s, 3H), 3.89(d, 1H,  $J=8.7$  Hz), 4.06(m, 2H), 4.58(d, 1H,  $J=8.7$  Hz, exchanged with  $\text{D}_2\text{O}$ ), 7.2-7.5(m, 5H);  $^{13}\text{C}$  NMR  $\delta$  14.0, 38.2, 62.0, 69.2, 127.7, 128.6, 141.6, 168.1, 170.0; ei-MS  $m/e$  237( $\text{M}^+$ , 10%), 164( $\text{M}^+-\text{COOEt}$ , 16%), 134( $\text{M}^+-\text{CH(OH)COOEt}$ , 100%); HR-MS calcd 237.10015, found 237.0961.

## References

1. (a) M.P. Doyle, *Chem. Rev.*, 1986, 86, 919.; (b) G. Mass. *In Topics in Current Chemistry, Organic Synthesis, Reactions and Mechanisms*. Vol. 137, Springer Verlag, New York 1987. p. 75.
2. (a) J.M. Mann, S.E. Piper, L.K.P. Yeung, *J. Chem. Soc., Perkin Trans.*, 1984, 2081; (b) J.L. Charlton, M.M. Alauddin, *J. Org. Chem.*, 1986, 51, 3490.
3. P. Magnus, T. Gallagher, J.C. Hoffmann, *J. Amer. Chem. Soc.*, 1982, 104, 1140.
4. H. Hikino, C. Konnu, *Heterocycles*, 1976, 4, 817.
5. J.Y. Gauthier, F. Bourdon, R.N. Young, *Tetrahedron Lett.*, 1986, 27, 15.
6. R.L. Danheiser, R.F. Miller, R.G. Brisbois, S.Z. Park, *J. Org. Chem.*, 1990, 55, 1959.
7. M. Regitz, *Synthesis*, 1972, 351.
8. A. Padwa, T.J. Wisnieff, E.J. Walsh, *J. Org. Chem.*, 1986, 51, 5036.
9. J. Adams, J. Rokach, *Tetrahedron Lett.*, 1984, 25, 34.
10. E. Wenkert, R. Decorzant, F. Nab, *Helv. Chim. Acta.*, 1989, 72, 756.
11. M. Hrytsak, T. Durst, *J. Chem. Soc., Chem. Comm.*, 1987, 1150.
12. J.F. Bunnet, *J. Amer. Chem. Soc.*, 1958, 80, 2021.
13. M.P. Doyle, M.S. Shanklin, S.M. Oon, H.Q. Pho, F.R. van der Heide, W.R. Veal, *J. Org. Chem.*, 1988, 53, 3384.
14. M.P. Doyle, M.S. Shanklin, H.Q. Pho, *Tetrahedron Lett.*, 1988, 29, 2639.

15. M.P. Doyle, J. Taunton, H.Q. Pho, *Tetrahedron Lett.*, 1989, **30**, 5397.
16. M.A. McKervey, S.M. Tuladhar, M.F. Twohig, *J. Chem. Soc., Chem. Comm.*, 1984, 129.
17. G.M. Rishton, M.A. Schwartz, *Tetrahedron Lett.*, 1988, **29**, 2639.

## CHAPTER 4

### Mechanistic studies of rhodium carbenoid reactions

#### Introduction

Diazo compounds have been utilized as precursors to carbenes since Curtius first described them in 1883.<sup>1</sup> Carbenes were generated from decomposition of diazo compounds either photolytically or thermally. In the presence of a catalytic amount of a transition metal such as  $\text{Cu}_2\text{Cl}_2$ ,  $\text{CuI}$  or  $\text{CuSO}_4$  carbenoids are generated.<sup>2</sup> In recent years, rhodium (II) and palladium (II) catalysts have been used to generate carbenoids under very mild conditions. With the advent of these two catalysts, diazo compound chemistry has received renewed interest. The application of diazo compounds to organic synthesis has been recently reviewed by Doyle and Mass.<sup>3</sup>

The word 'carbenoid' was first used by Nozaki in 1966 to describe the transient intermediate generated by a transition metal which is neither a carbene nor an activated diazo compound.<sup>4</sup> As early as 1952, Yates had suggested that transition metals such as copper reacted with diazo compounds to generate a transient electrophilic metal carbene.<sup>5</sup> To date, no one has actually observed or

isolated this intermediate carbenoid, but its existence is widely accepted on the basis of comparison with similar model systems.

The ability of transition metals to decompose diazo compounds catalytically can be explained in the following way. Electrophilic attack of the catalyst on the diazo compound with simultaneous or subsequent loss of nitrogen and possible displacement of one of the metal's ligands as an anionic species occurs to give rise to two possible intermediates; either a metal carbene or an ion pair. The metal-carbene complex can then undergo typical carbenoid reactions with electron-rich substrates to complete the catalytic cycle.

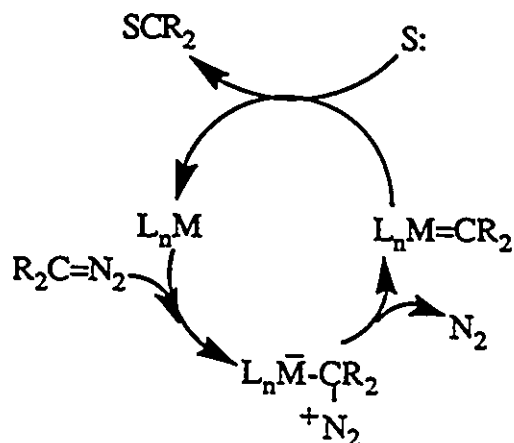

The formation of the ion pair or ylide in scheme 1 can be explained as a carbene insertion into a metal-ligand bond. This reaction has been observed between metal halides and diazo compounds.<sup>2</sup>

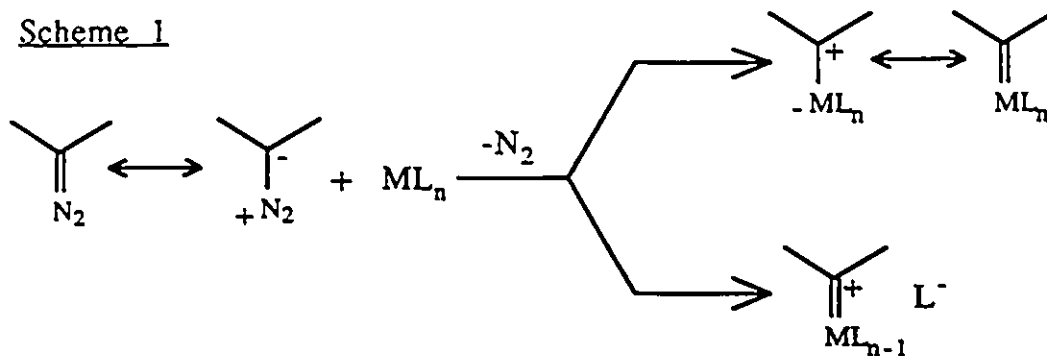

Rhodium (II) acetate, palladium (II) acetate, and copper (I) triflate have been used as catalysts for diazo insertion reactions. Teyssie and coworkers systematically studied cyclopropane ring formation from diazo compounds and olefins in the presence of metal catalysts.<sup>6</sup> They proved that rhodium (II) carboxylates were far superior to the other two catalysts for this reaction. The superiority of rhodium (II) carboxylates was explained as being due to the presence of only one available site for coordination, so that a carbon-metal bond is formed which allows it to operate as a carbenoid. (See figure below.) In the case of palladium there is more than one site available. Palladium is known to complex with olefins and may be expected to react with the olefin as well as the diazo compound, thus lessening its effectiveness.

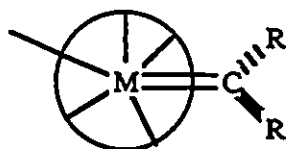

Aratani found that a copper chelate compound having bulky chiral ligands was able to catalyze the asymmetric cyclopropanation

reaction of 2,5-dimethyl-2,4-hexadiene with ethyldiazoacetate to give chrysanthemic ester, **2**, in 60% enantiomeric excess.<sup>7</sup> (Scheme 2) This suggests that the free carbene is unlikely to exist in this case. The chiral ligands must be in close proximity to the reaction centre, so that asymmetric induction can be observed. Nozaki and Noyori's coworkers also observed asymmetric induction in cyclopropanation reactions when they used chiral copper chelates.<sup>8,9</sup>

Scheme 2

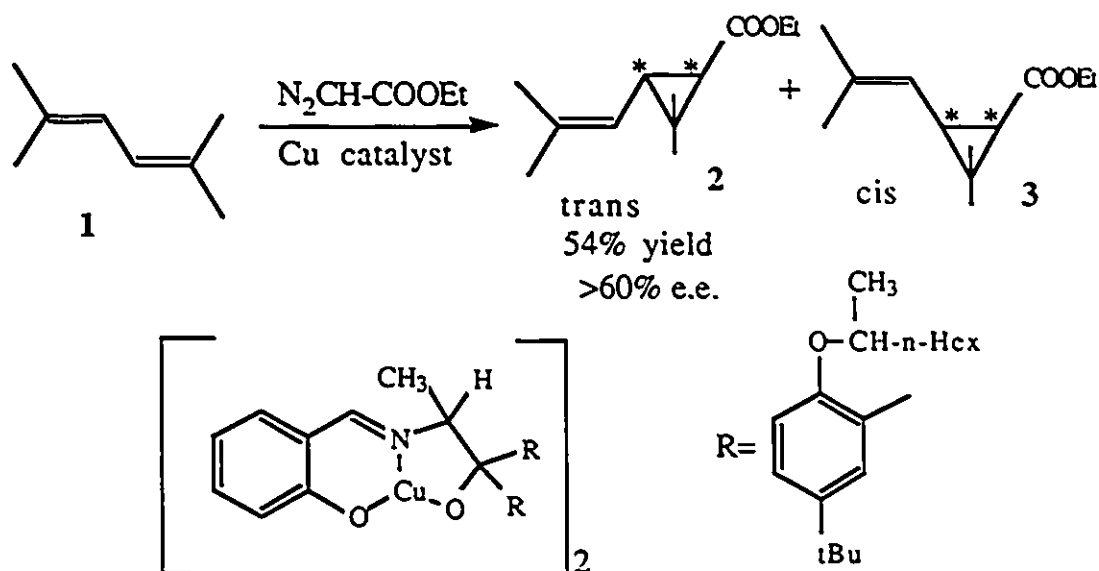

Metal complexes whose structures are known display the same selectivity with the same substrates as transient carbenoid intermediates of assumed similar structure. Casey et al studied cyclopropanation reactions of various alkenes with  $(\text{CO})_5\text{WCHPh}$  which formed a mixture of cis and trans products.<sup>10</sup> Doyle et al were concerned with the formation of cyclopropanes from various alkenes such as vinyl ethers, vinyl acetates, cyclopentene, styrene and substituted and unsubstituted alkenes with phenyldiazomethane in

reactions catalyzed by rhodium acetate.<sup>11</sup> These workers also observed the formation of cis and trans isomers. The same cis to trans isomers were obtained by both the Doyle and Casey groups. Both metal carbenes can be thought of as consisting of a metal atom surrounded by ligands, with one coordination site occupied by the carbenic carbon and its substituents. The studies done by Doyle, Noyori, and Aratani conclusively prove that metal catalyzed diazo insertion reactions are those of carbenoid reactions rather than free carbene species.

#### **Intermolecular reactions of rhodium carbenoids with aromatic substrates**

Teyssie *et al* found that a catalytic amount of rhodium carboxylate decomposes alkyl diazoacetates. Such a decomposition when carried out in the presence of a large excess of aromatic substrate, produces cycloheptatrienes, 5, in very high yields. These compounds result from bond reorganization of the initially formed norcaradienes, 4, at room temperature. They utilized benzene, toluene, xylene, anisole, and chlorobenzene as aromatic substrates and methyl, ethyl, and t-butyl diazoacetates as representative examples of alkyl diazoacetates.<sup>12</sup>

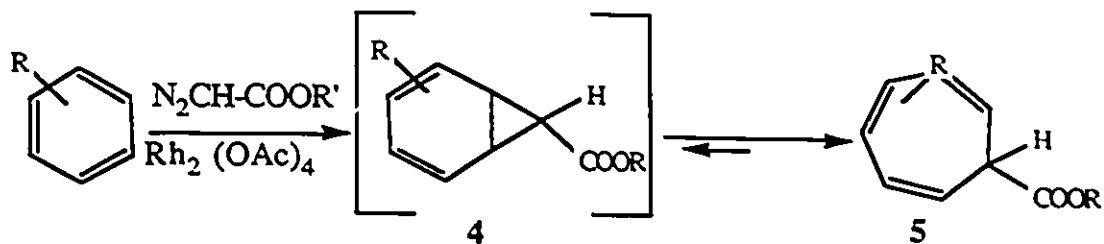

In contrast, Shechter reported that rhodium acetate catalyzed decomposition of 2-diazo-1,3-indandione in refluxing benzene gave only the aromatic substitution product, 8. No traces of a norcaradiene intermediate or cycloheptatrienone were detected.<sup>13</sup> With electron-rich anisole a parasubstituted product, and with toluene and chlorobenzene mixtures of ortho and para substituted products were obtained. (Scheme 3)

Scheme 3

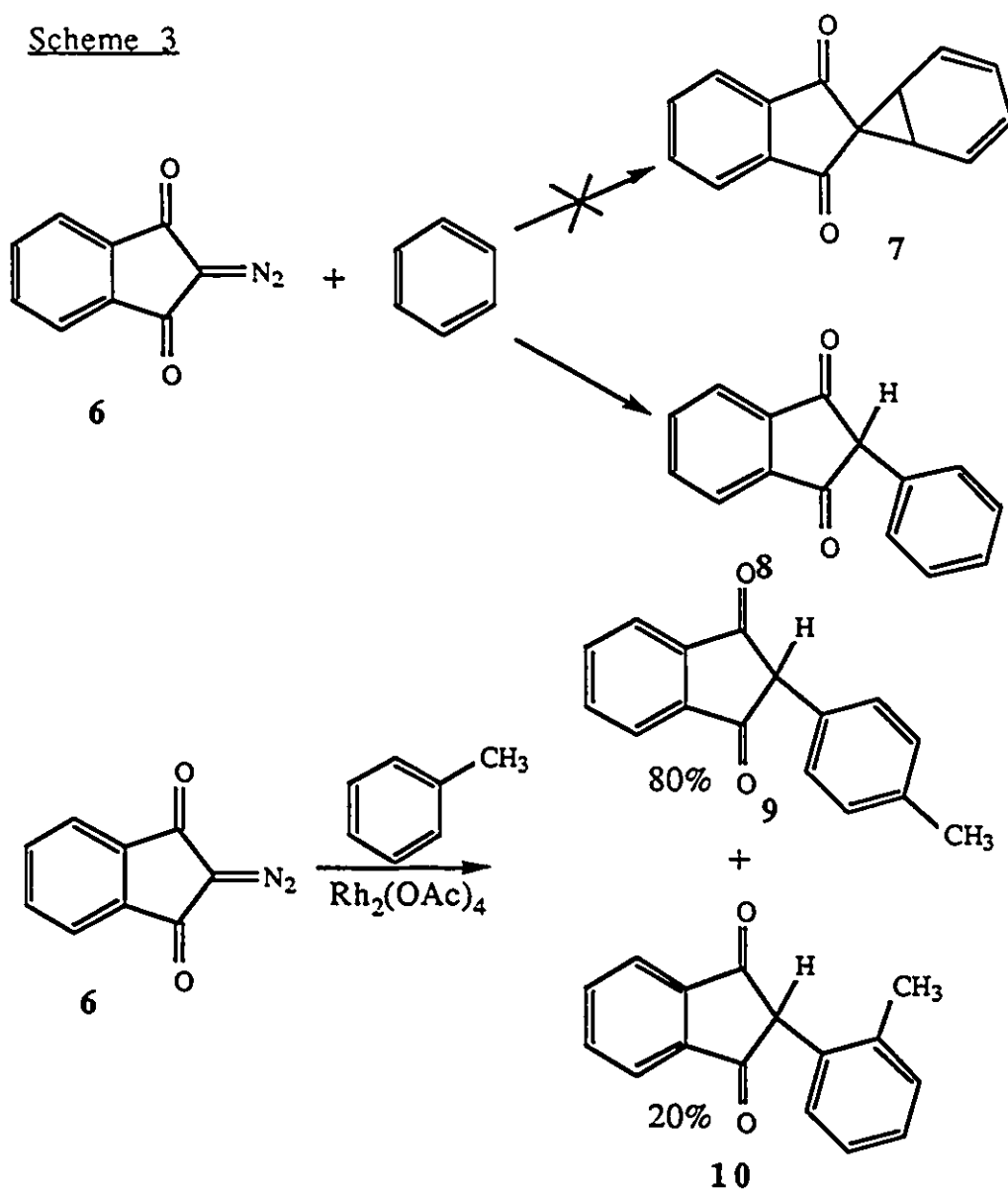

It is important to recall that norcaradienes bearing two electron withdrawing groups (CN, COOEt) have considerable stability<sup>14</sup> and thus it is reasonable to expect that **7** should have been detected by Shechter if it were an intermediate. In the case of the rhodium carbenoid derived from **6** Shechter concluded that it reacted with aromatic compounds by direct electrophilic substitution.

### Intramolecular reactions of rhodium carbenoids with aromatic substrates

McKervey demonstrated that the intermolecular reaction of benzene with various  $\alpha$ -diazoketones in the presence of a catalytic amount of rhodium trifluoroacetate produced non-conjugated cycloheptatrienes, **11**, again via a norcaradiene intermediate.<sup>15</sup> These compounds formed the benzyl ketones, **12**, in quantitative yields on exposure to trifluoroacetic acid.

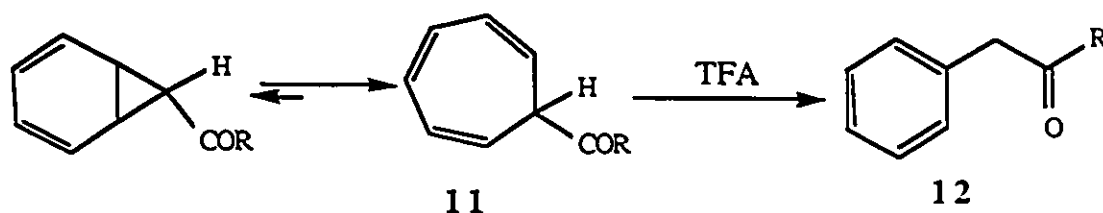

The same authors observed similar results when they subjected 1-diazo-4-phenylbutan-2-one derivative, **13**, obtained by reaction of  $\text{CH}_2\text{N}_2$  and 3-phenylpropanoyl chloride, to rhodium acetate in methylene chloride. This combination led to the formation of bicyclo(5,3,0)decatrienone, **14**, in near quantitative yield.<sup>16</sup> Subsequent treatment of these compounds with a catalytic amount of TFA (trifluoroacetic acid), gave the 2-tetralone, **15**.

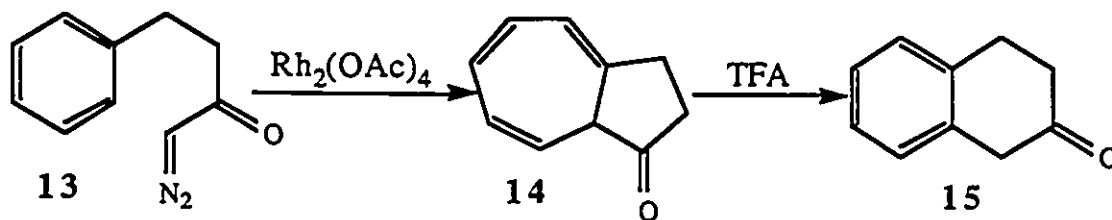

Recently Padwa and coworkers isolated and characterized

spectroscopically a cyclopropane intermediate in the conversion of thienyl diazoketone to benzothiophen-5(4H)-one.<sup>17</sup>

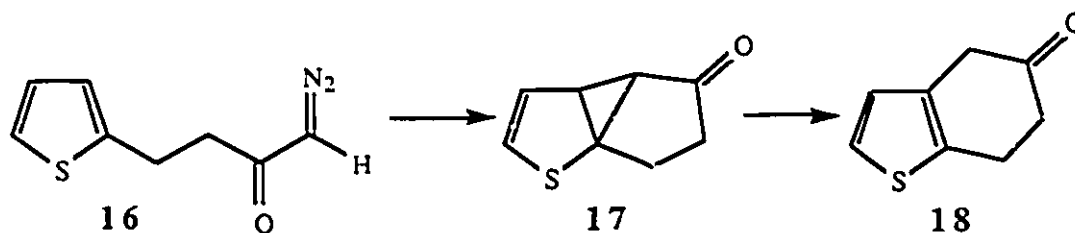

Nakatani has prepared 2-indanones from  $\alpha$ -diazoketones. He used a similar procedure to McKervey's for his synthesis. He did not isolate or identify any cycloheptatrienone or norcaradiene intermediate.<sup>18</sup>

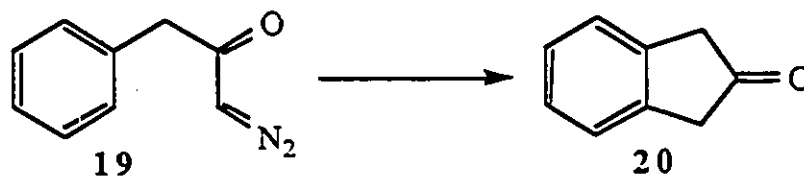

Matsumoto also failed to observe formation of cycloheptatrienes when he treated an  $\alpha$ -diazo- $\beta$ -ketoester derived from indole with rhodium acetate or palladium acetate.<sup>19</sup> He obtained a fused 5-membered ring with rhodium acetate, and a 6-membered ring when palladium acetate was used as a catalyst.

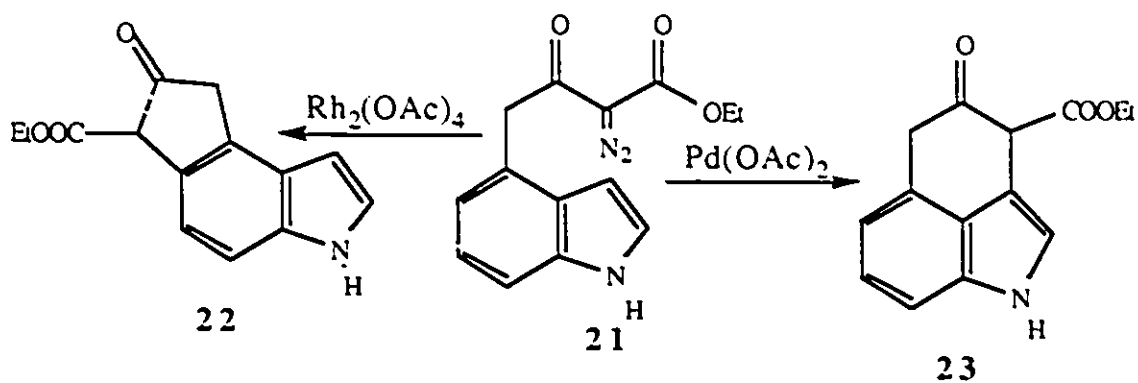

In work reported from this laboratory<sup>20,21,22,23</sup> involving rhodium acetate catalyzed reactions of diazo compounds bearing two electron withdrawing groups such as COOEt, SO<sub>2</sub>, COCH<sub>3</sub> and R<sub>2</sub>NCO only the annulated products, 25 and 27 were obtained. No evidence for the intermediacy of cycloheptatrienes in these reactions was obtained. (Scheme 4)

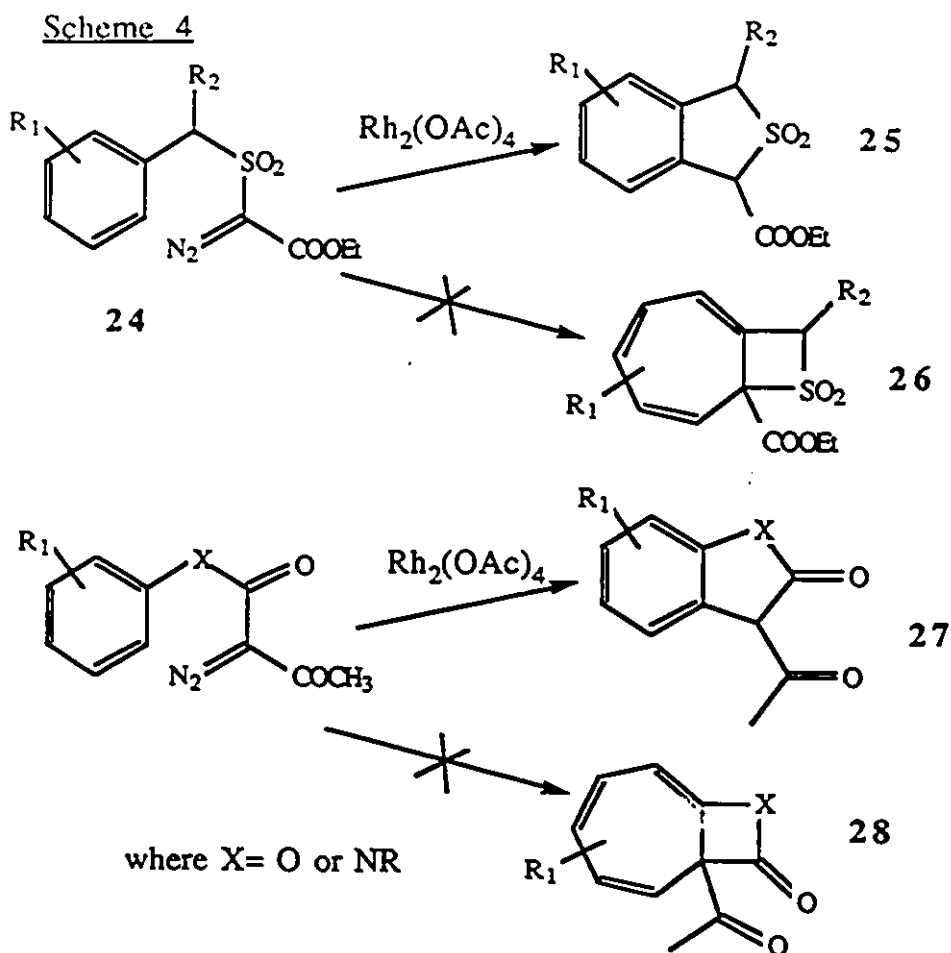

Interestingly attempts to prepare 6,6 fused systems such as 30 were unsuccessful in our hands except in the case of the  $\alpha$ -diazo- $\beta$ -ketoester, 33, derived from thienyl bromide. For example, when we attempted to cyclize benzyl  $\alpha$ -diazoacetate to 30 in presence of rhodium acetate none of the expected product, 30, was found. Careful chromatography of the crude reaction mixture afforded a 5-10% yield of benzalacetone. The formation of this compound is rationalized as the result of an insertion into the benzylic C-H bond to yield a  $\beta$ -lactone followed by  $\text{CO}_2$  extrusion.<sup>24</sup> (Scheme 5)

Although the comparison is not completely valid, it appears that in both the inter and intramolecular reactions of rhodium carbenoids with aromatic substrates the carbenoids bearing one electron withdrawing group behave differently than those carrying two such groups. In the case of the former reagents cyclopropanation appears to be the dominant reaction pathway while the latter reagents appear to give aromatic substitution products without proceeding through three membered ring intermediates.

Scheme 5

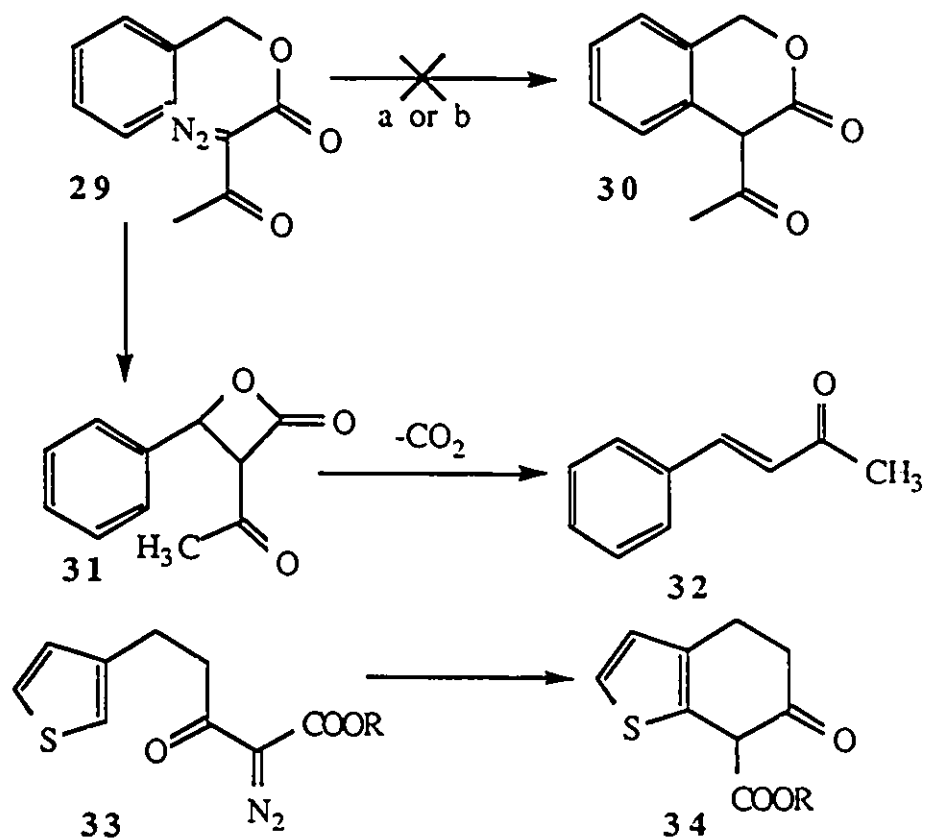

### Insertion of rhodium carbenoids into aliphatic C-H bonds

Taber et al studied several reactions of  $\alpha$ -diazo- $\beta$ -ketoesters catalyzed by rhodium acetate.<sup>25</sup> These reactions afforded excellent yields of 5-membered rings products such as **12** with no identifiable traces of 6-membered ring products. They explained the strong preference for the formation of the 5-membered ring products by a rhodium carbenoid insertion reaction via a 6-membered ring metallocycle. In the case of the 6-membered ring a less favoured 7-membered ring transition state or metallocycle is required. (Scheme 6) In the course of these investigations they synthesized (+)- $\alpha$ -cuparenone, **39**.<sup>26</sup>

Scheme-6

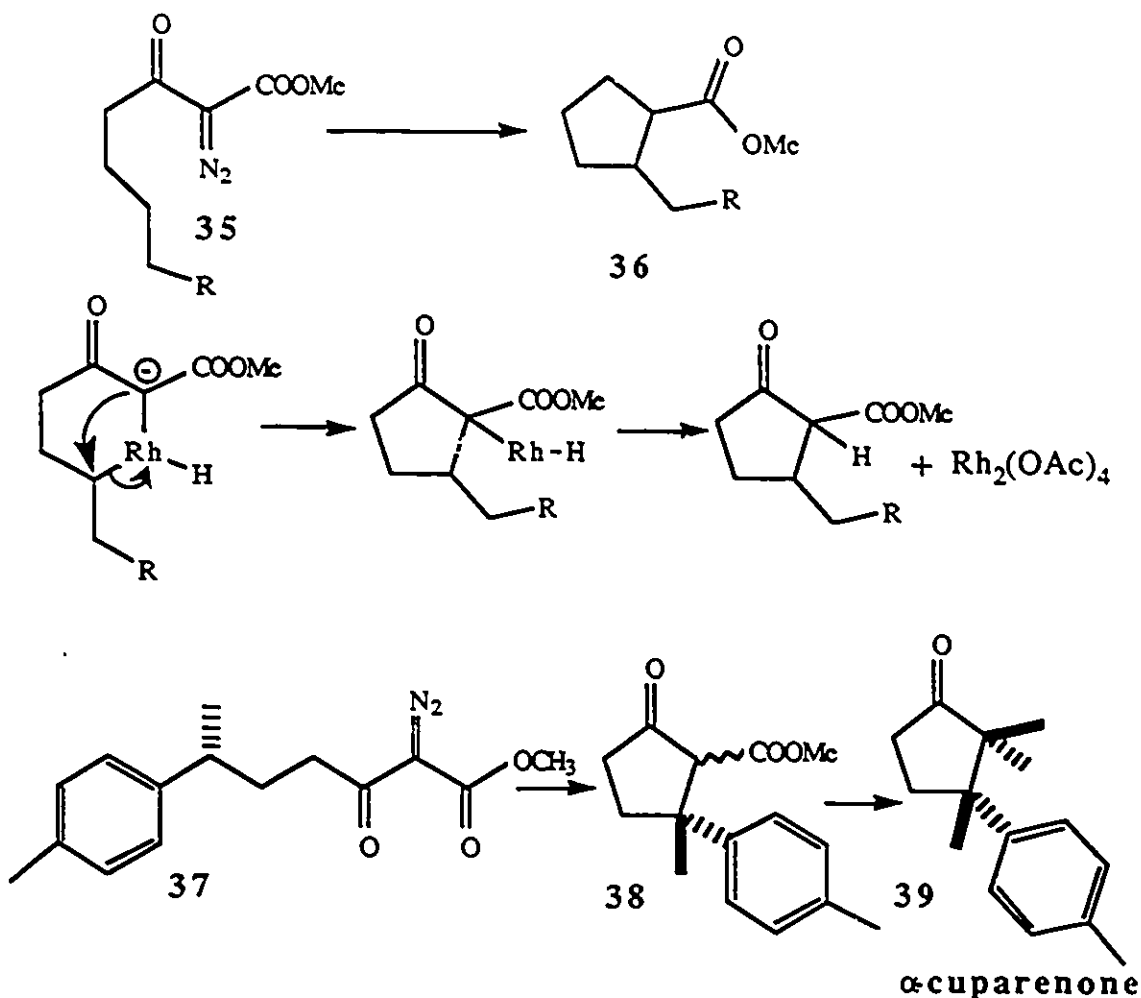

The findings of Stork and Nakatani from Columbia University contributed to and supported Taber's recognition of the formation of 5-membered rings in the rhodium catalyzed C-H bond insertion reaction of diazo compounds.<sup>27</sup> The product obtained from the reaction of **42** showed that these carbenoids prefer to insert into the more electron rich gamma C-H bond. Thus reaction of **42** with rhodium acetate afforded only product resulting from C-H insertion at the position remote from the electron withdrawing ester group. (Scheme 7)

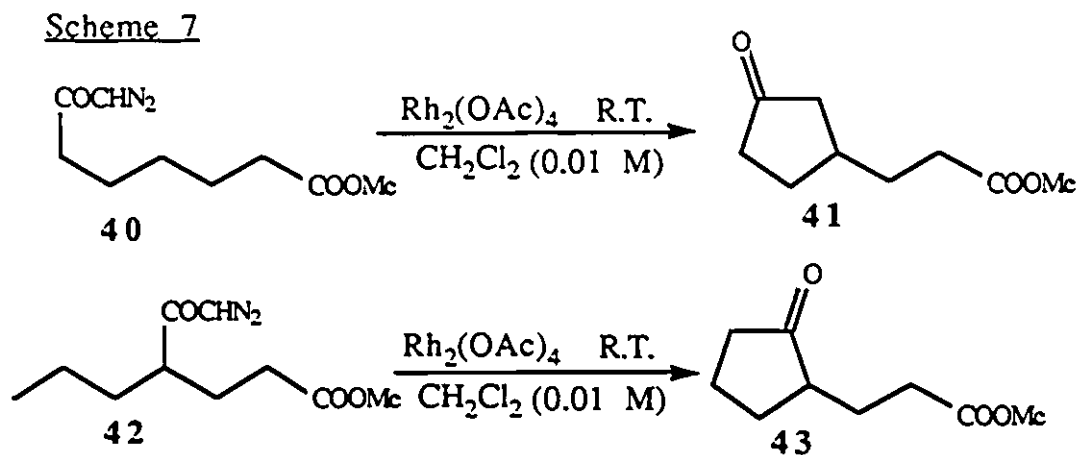

### Competition between aliphatic C-H insertion and aromatic substitution reactions

In addition Nakatani also noted that  $\alpha$ -diazoketones prefer formation of aromatic substitution products resulting in the formation of 6,5 fused rings over the  $\gamma$ -aliphatic C-H insertion products.<sup>18</sup> Our own observations were similar to theirs. When we treated an  $\alpha$ -diazo- $\beta$ -ketoamide derived from tetrahydroquinoline with rhodium acetate it formed 47 (45%); no aliphatic C-H insertion product was detected. (Chapter 3)

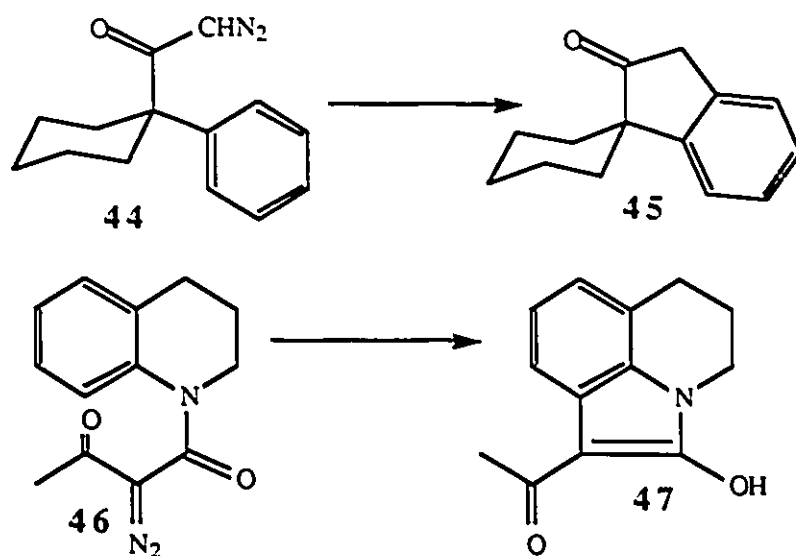

Julian Adams published recent work in *Tetrahedron Letters* which complemented the above conclusions.<sup>28</sup> When he treated the diazoketone, 48, derived from Mosher's acid, with rhodium acetate he obtained a mixture of 49 and 49a. The aromatic substitution product was found to be predominant.

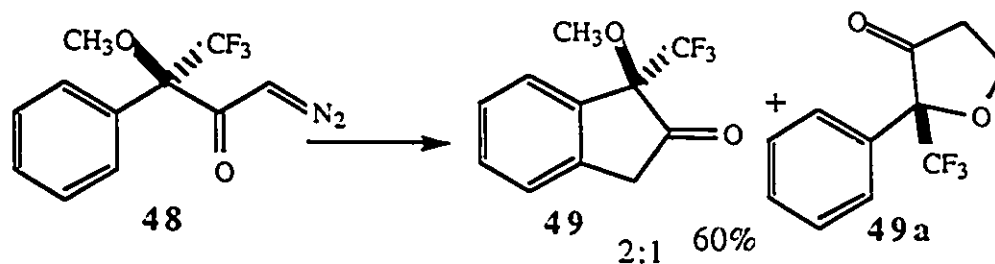

Based on the above literature examples the following generalizations can be made:

(1) No cycloheptatriene intermediates were detected during either the inter- or intramolecular reaction between rhodium carbenoids bearing two electron withdrawing groups and aromatic substrates. With carbenoids bearing one electron withdrawing group cyclopropane intermediates (norcaradienes) are formed as isolable intermediates except in the Nakatani example leading to 2-indanone where such an intermediate might be judged to be excessively strained.

2. Intramolecular aromatic substitution reactions of rhodium carbenoids bearing two electron withdrawing groups give good to excellent yields of 6,5 fused products. The homologated 6,6 ring systems are generally not observed.

(3) Rhodium acetate catalyzed diazo insertion reactions which result in a formal aromatic C-H bond insertion (aromatic substitution) are preferred over insertion into the  $\gamma$ -aliphatic C-H bond.

(4) Rhodium catalyzed diazo insertion reaction into electron rich aliphatic C-H bonds are favoured compared to those adjacent to the electron withdrawing groups.

The results described above concerning reactions with aromatic substrates can be explained by one or more combinations of several possible mechanisms described below.

- (a) Electrophilic aromatic substitution followed by proton transfer.
- (b) Cyclopropanation (norcardiene formation) followed by ring opening and rearrangement.
- (c) Direct insertion. (oxidative addition, reductive elimination)

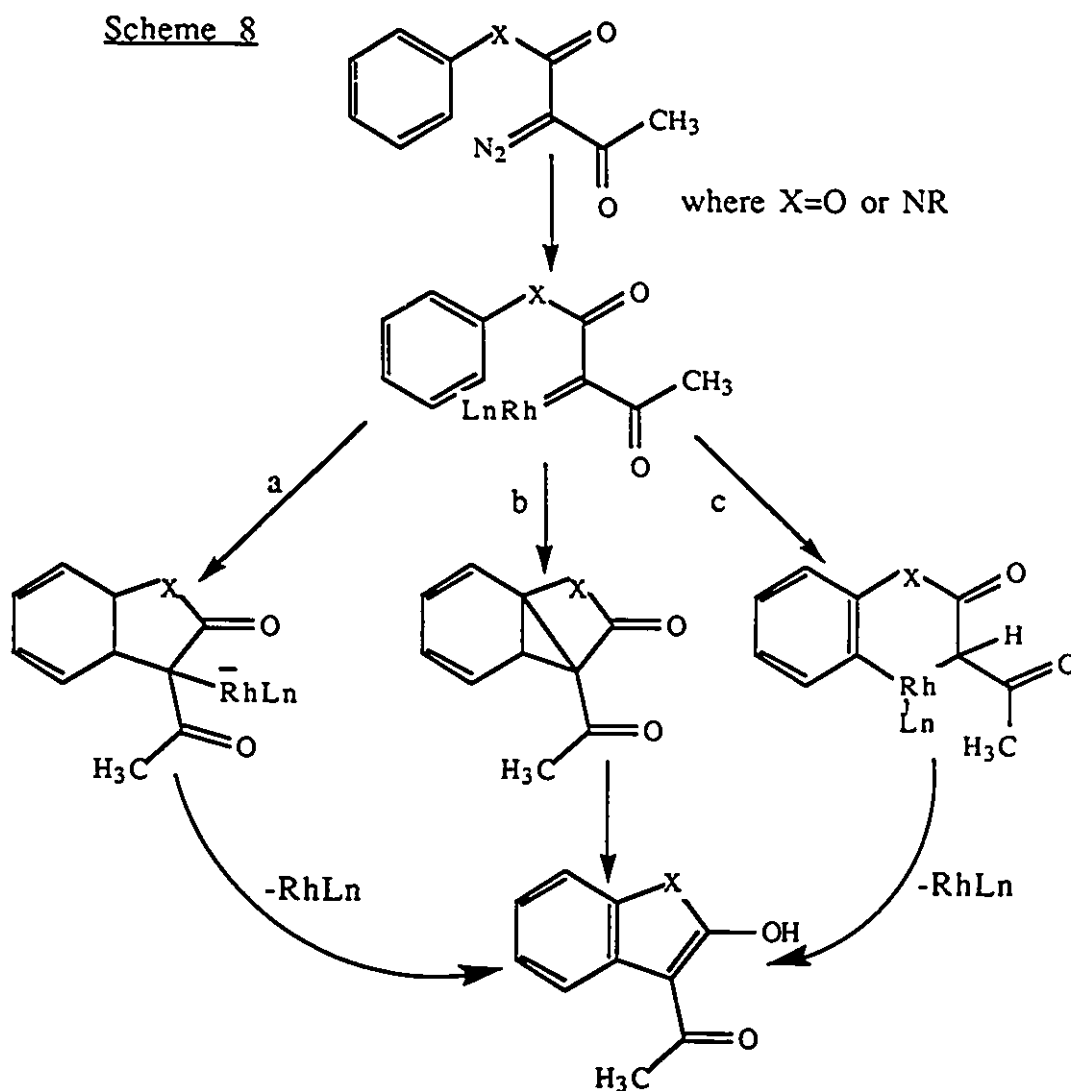

## Results and Discussion

### Introduction

We decided to conduct deuterium isotope experiments in order to gain further insight into the mechanism of the rhodium carbenoid reaction. The simple idea was to determine if the breaking of the ortho C-H (C-D) bond occurred during the rate determining step. Typically, the  $k_H/k_D$  is  $<1.3$  in reactions in which the C-H/C-D bond is not broken in the rate determining step and  $>2$  in reactions in which it is. Based on literature precedences we felt that the mechanisms (a) and (b), above, would be unlikely to have the C-H bond breaking involved in the rate determining step. On the other hand, the direct insertion (metallocycle) mechanism which requires the participation of rhodium metal via oxidative addition and reductive elimination sequence, should have the C-H/C-D bond breaking process in its rate determining step.

Perhaps the most closely related example to the aromatic substitution mechanism (a) is the cyclization of the acid chloride **50** and acid **51** to indanones. Denney and Klemchuck<sup>29</sup> found hydrogen deuterium isotope effects of  $<1.4$  in the  $\text{SnCl}_4$  or  $\text{ZnCl}_4$  catalyzed cyclization of the monodeuterated acid chloride, **50** in benzene, and the sulfuric or polyphosphoric acid catalyzed cyclization of the corresponding acid **51**. Higher isotope effects have been observed in the cyclization of **50** in the more polar solvent  $\text{SO}_2$ , and when  $\text{AlCl}_3$  was used as catalyst. The higher values were ascribed to the greater stability of the intermediate **52** under the reaction conditions and a

change in the rate determining step. ( $k_{-1} > k_2$ ) Since the rhodium carbenoid reactions were carried out in the relatively non polar solvent,  $\text{CH}_2\text{Cl}_2$ , the formation of the  $\sigma$ -complex should be the rate determining step.

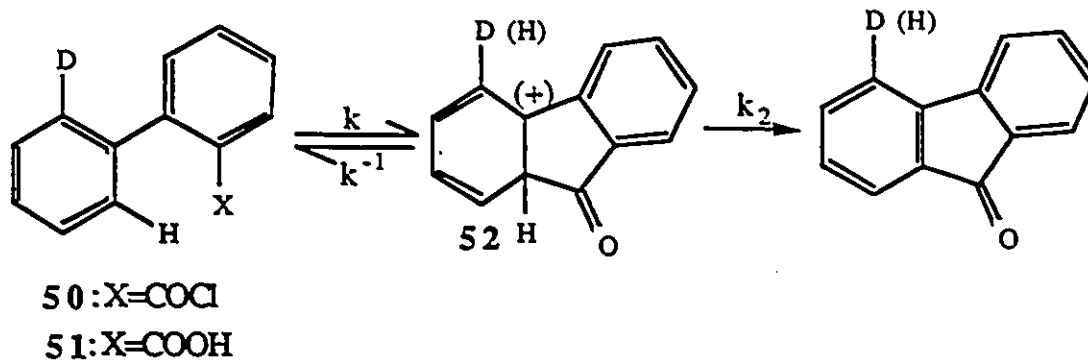

Although we have no specific examples we find it difficult to imagine that the formation of the norcaradienes is reversible. The  $k_{\text{H}}/k_{\text{D}}$  for this reaction can only be a secondary isotope effect and should be less than 1.4.

Finally in agreement with our predictions, Nicholson has reported that the ortho metallation of the acetophenone derivative 53 with manganese pentacarbonyl complex, 54, showed a  $k_{\text{H}}/k_{\text{D}} = 3.0$ .<sup>30</sup>

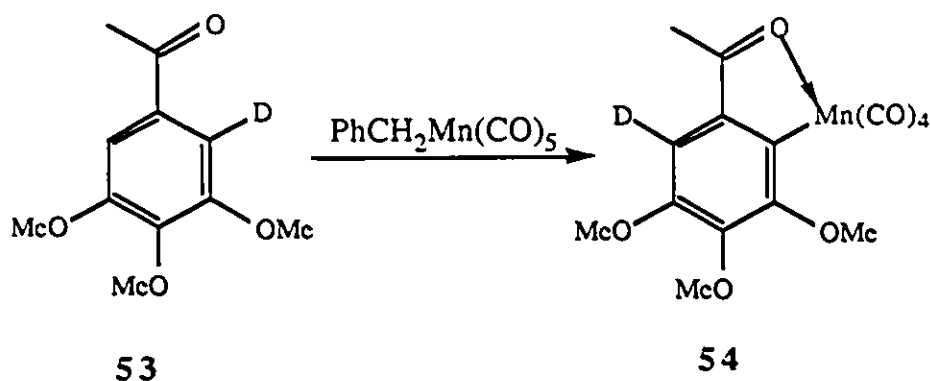

M. Hrytsak<sup>22</sup> carried out the initial studies on deuterium isotope effects on the partially deuterated  $\alpha$ -diazo- $\beta$ -keto ester 57 and found a  $k\text{H}/k\text{D}$  value of 2.65 for the formation of 3-acetyl-2-hydroxy benzofuran.

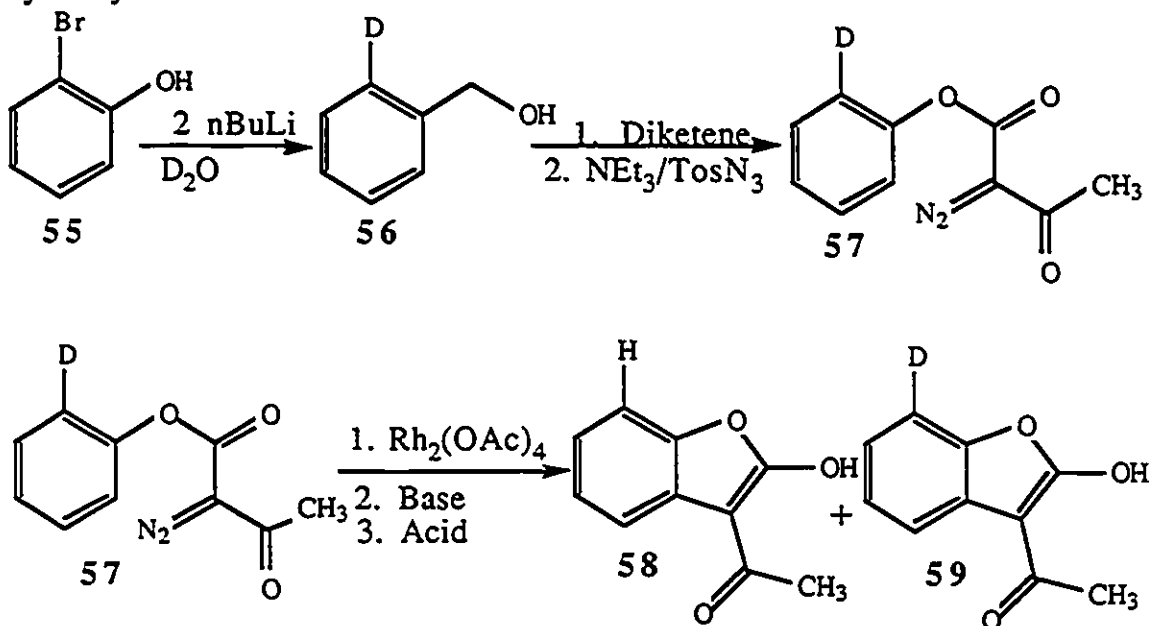

This finding indicates that considerable rupture of the ortho C-H (C-D) bond was involved in the rate determining step. Hrytsak interpreted this result as favouring a mechanism involving the direct

insertion of a rhodium carbenoid into the aryl C-H (C-D) bond (metallocycle **60**), rather than an electrophilic aromatic substitution (intermediate **61**), or addition to the aryl  $\pi$  bond to form a norcaradiene. (intermediate **62**)

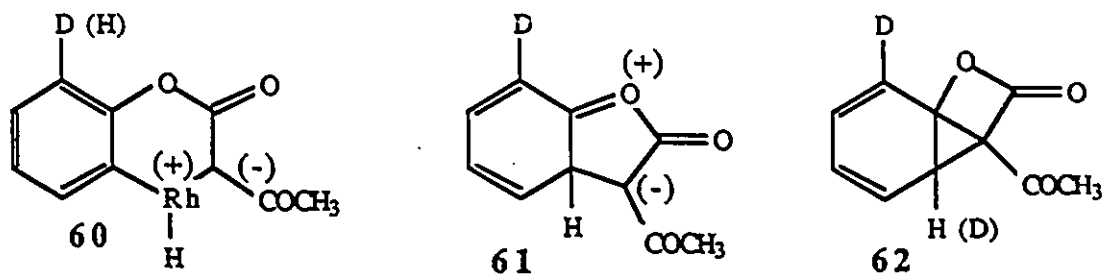

After M.Hrytsaks' result, we decided to measure the deuterium isotope effects in the formation of 1,3-dihydrobenzothiophene-2,2-dioxides, 2-indanone and 2-tetralone. In the first two cases, no traces of formation of norcaradiene was reported. But in the later the formation of a norcaradiene intermediate was observed by McKervey *et al.* On the basis of the above discussions and Hrytsaks' result, we expected a  $kH/kD > 2.5$  for the first two cases. In the case of McKerveys' diazo compound **67** we expected a small secondary deuterium isotope effect.

All of the three deuterated diazo compounds required for this study were prepared from the monodeuterated benzyl alcohol, **64** which was prepared from *o*-bromobenzyl alcohol by sequential treatment with NaH, *n*-BuLi and D<sub>2</sub>O.

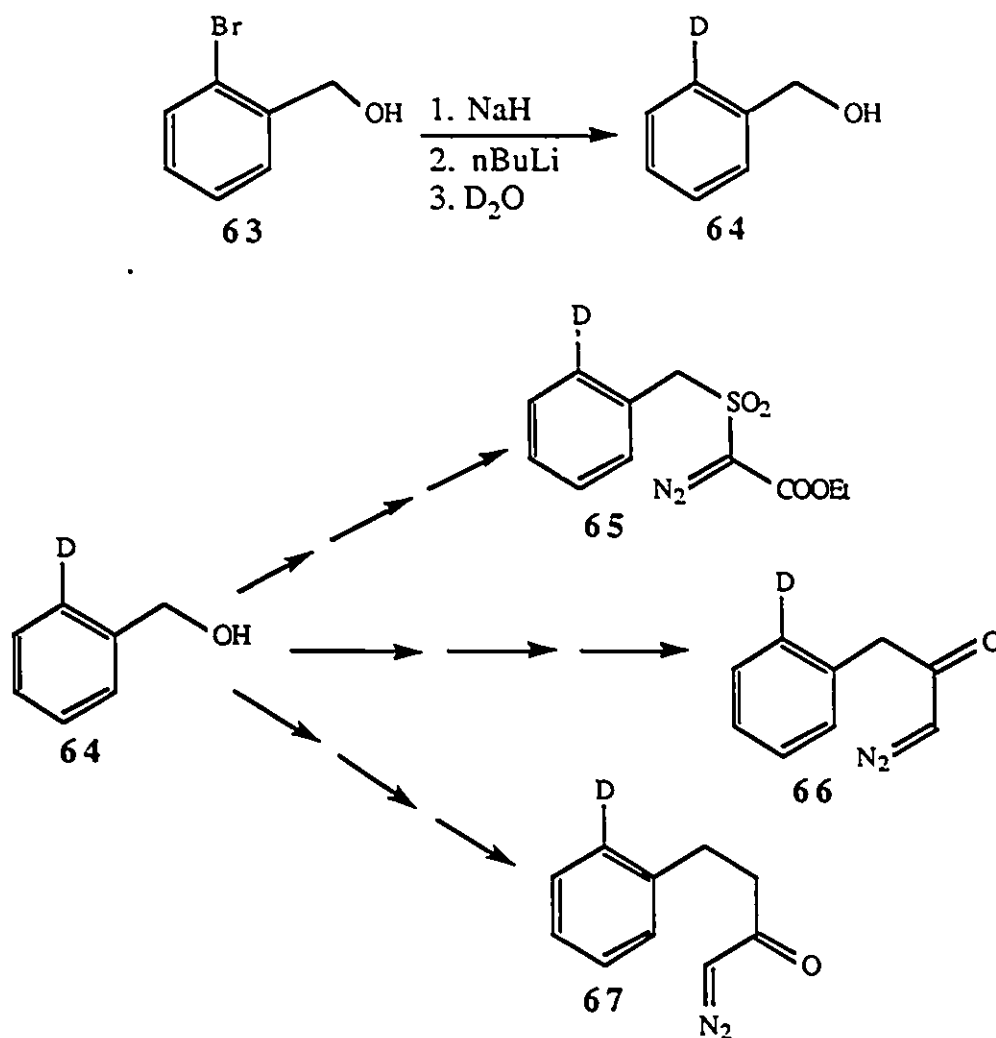

Benzyl alcohol, 64, was converted into the sulfide with ethyl mercaptoacetate and zinc iodide which subsequently was oxidized to the sulfone. The sulfone was diazotized with NaH and TosN<sub>3</sub> to furnish 65. This procedure was identical to that used for the nondeuterated analogue.(see Chapter 3)

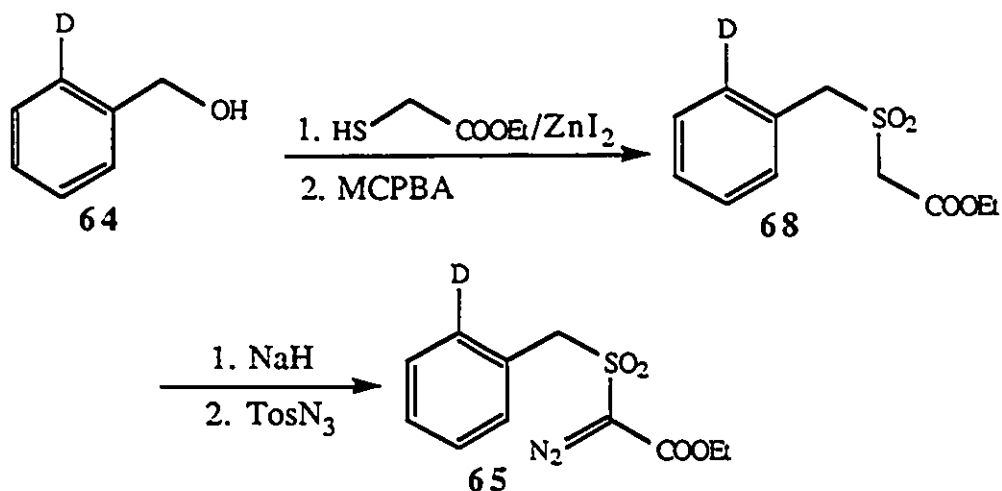

The  $\alpha$ -diazoketone 66 was obtained from 64 as shown below. Details of the steps are given in the Experimental Section.

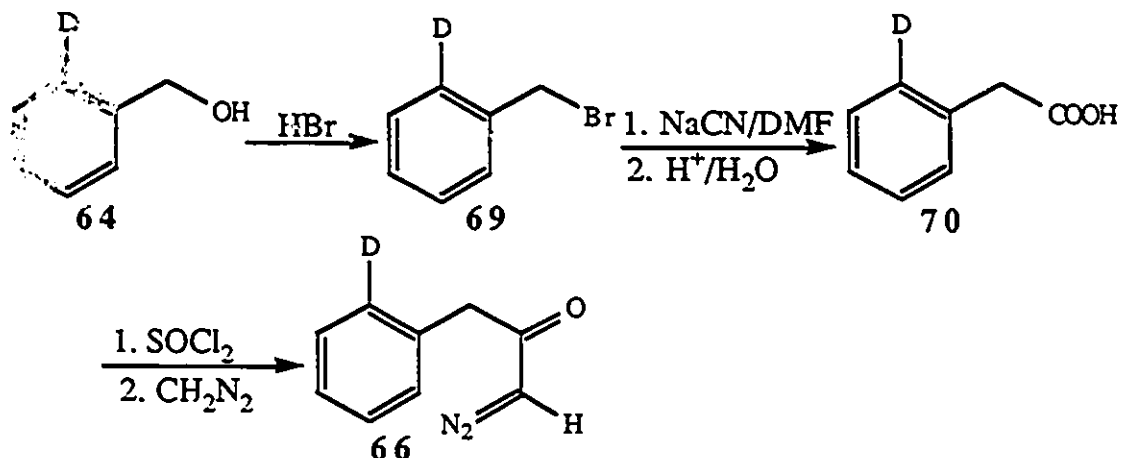

Deuterated benzyl bromide, on treatment with Wittig ylide followed by hydrolysis, formed the 3-arylpropionic acid 71 in 63 % yield. The acid was then converted to its acid chloride and to the required diazo compound upon reaction with thionyl chloride and diazomethane, respectively.

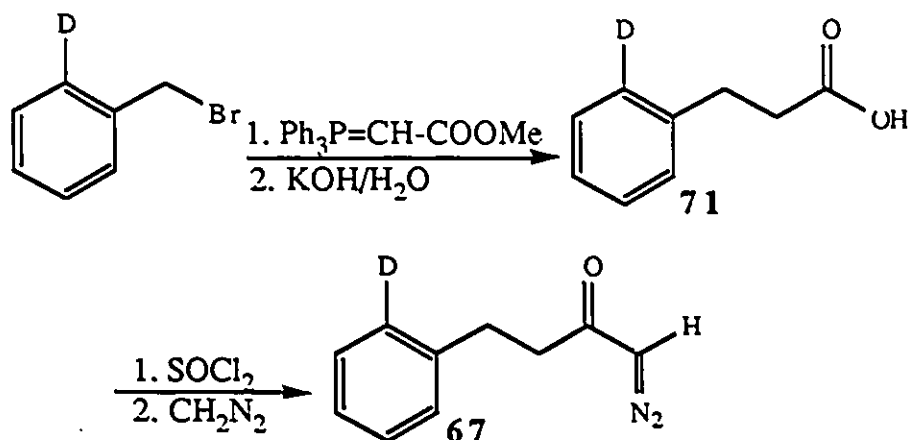

IR spectroscopy was used extensively to monitor the desired changes during the above mentioned syntheses. For example, the benzylic cyanide intermediate in the synthesis of 66 was identified by the presence of a peak at  $2260 \text{ cm}^{-1}$ , the corresponding acid by a broad peak at  $3500\text{-}2500 \text{ cm}^{-1}$ . Conversion of the acid to the acid chloride was confirmed by the appearance of a strong band at  $1800 \text{ cm}^{-1}$ . Finally, the characteristic peak for the diazo compound appeared at  $2120 \text{ cm}^{-1}$ .

The percentage of deuterium present on the aromatic ring of the benzyl alcohol 64 was calculated using mass spectroscopy. An  $M^+$  peak appeared at  $m/e=108$  along with peaks at  $m/e=105\text{-}107$  for the non-deuterated benzyl alcohol. For the deuterated benzyl alcohol the analogous peaks appeared between  $m/e=106\text{-}109$ . On the basis of the relative sizes of each of these peaks the aromatic ring was calculated to be 91% monodeuterated. (See Experimental Section)

Diazo compound 65 on treatment with rhodium acetate in methylene chloride provided the cyclic sulfone 72 in 65% yield. The

crude sulfone was treated with base followed by acidification and extraction into methylene chloride to remove any traces of deuterium present at the carbon flanked by the sulfone and ester groups.

Mass spectral analysis of the product obtained showed that it contained 75.5% of one deuterium atom/molecule. The loss of deuterium during the cyclization was 15.5%. This corresponds to a  $K_H/K_D = 75.5/15.5 = 4.9$ .

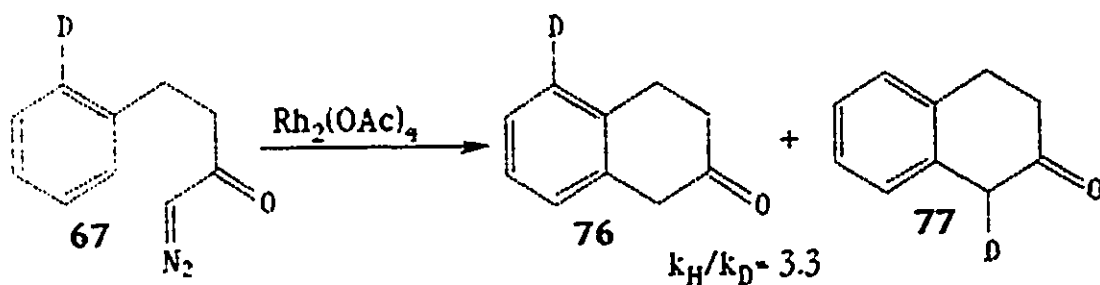
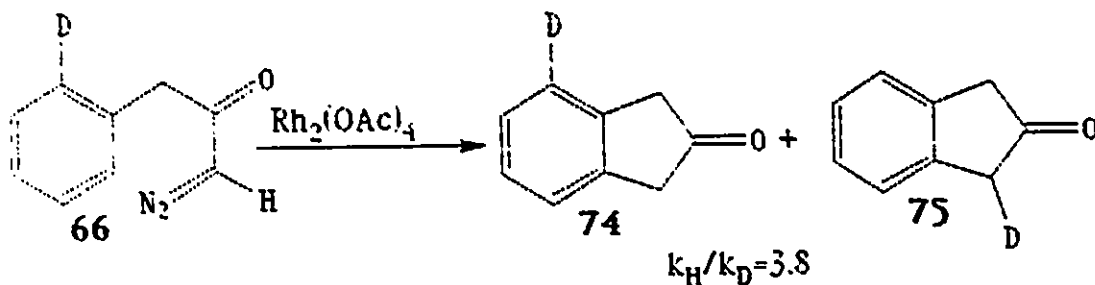
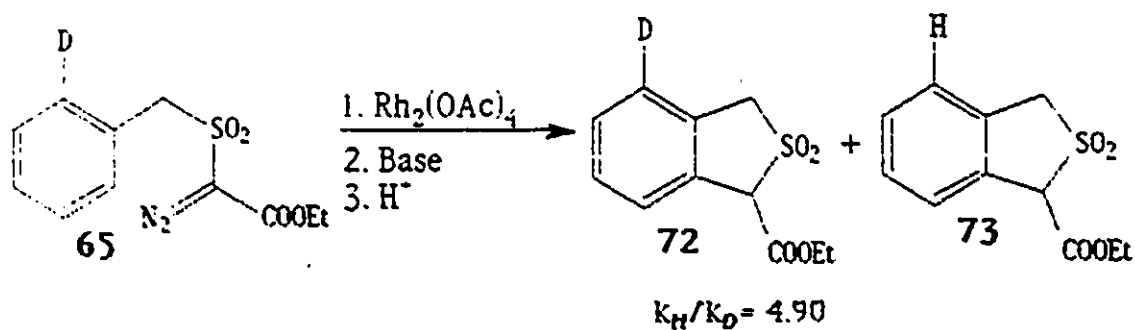

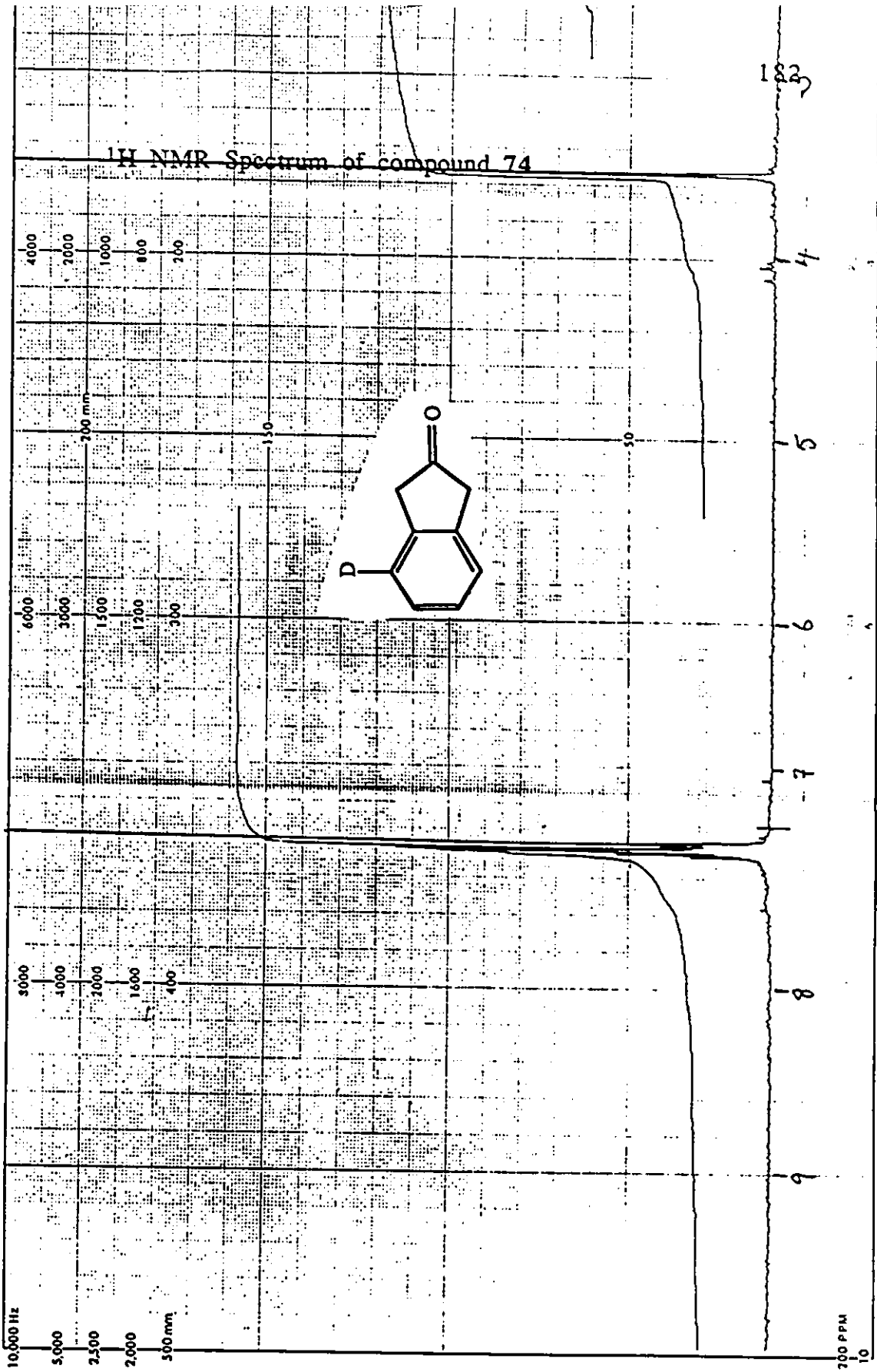

<sup>2</sup>H NMR Spectrum of compound 74

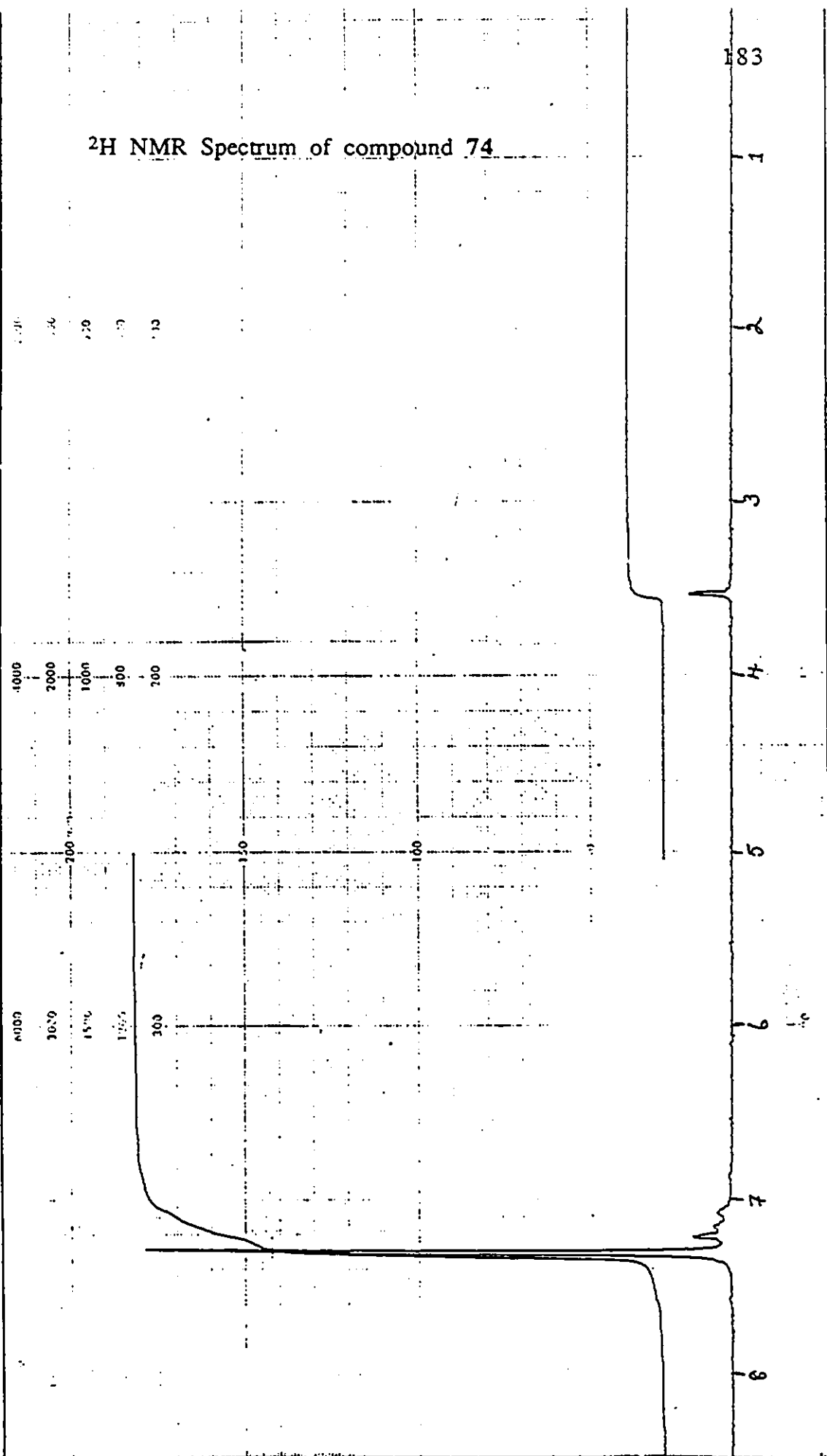

Treatment of **66** (0.97 D/molecule) with 10 mol% of rhodium acetate in methylene chloride afforded 2-indanone as described by Nakatani.<sup>18</sup> The total amount of deuterium present in the cyclized product was determined in the usual way by mass spectroscopy to be 83.4%. The deuterium NMR spectrum showed that the product was a mixture consisting of **74** and **75** in 93:7 ratio. Thus the amount of deuterium remaining on the aromatic ring is  $83.4 \times 93$  or 77% of 1 deuterium atom. The ratio of loss of deuterium /hydrogen from the aromatic ring during the cyclization gives a value of  $K_H/K_D = 77/(97-77) = 3.8$

When we subjected the diazoketone **67** (0.82 D/molecule) to treatment with rhodium acetate it formed 2-tetralone **76** in 70% yield after silica gel chromatography. No attempt was made to isolate or characterize the expected norcaradiene-cycloheptatriene intermediate. By mass spectroscopy the product was found to be 63% mono-deuterated. In the deuterium NMR no signal was found corresponding to compound **77**, indicating that all the deuterium was attached to aromatic ring. Since the starting diazo compound was 82% mono-deuterated the ratio of loss of protium to deuterium is 63/82-63. Thus  $K_H/K_D = 63/19 = 3.3$

We had anticipated similar  $K_H/K_D$  values for the conversion of **65** to **72** and **66** to **74** as had been observed for **57** to **59**. Indeed,  $K_H/K_D$  values of 4.8 and 3.8, respectively, were found. For the conversion of **67** to **76** a small isotope effect was expected since McKervey et al had shown the intermediacy of the cycloheptatriene **14** in this transformation.<sup>16</sup> However value of 3.3 was found. Furthermore, careful examination of the product **76** by deuterium

NMR showed that the deuterium remaining on the aromatic ring was located at two different positions ( $\delta = 7.11, 7.02, 1.9:1$ ), presumably C<sub>5</sub> and C<sub>8</sub> (76 and 76a).

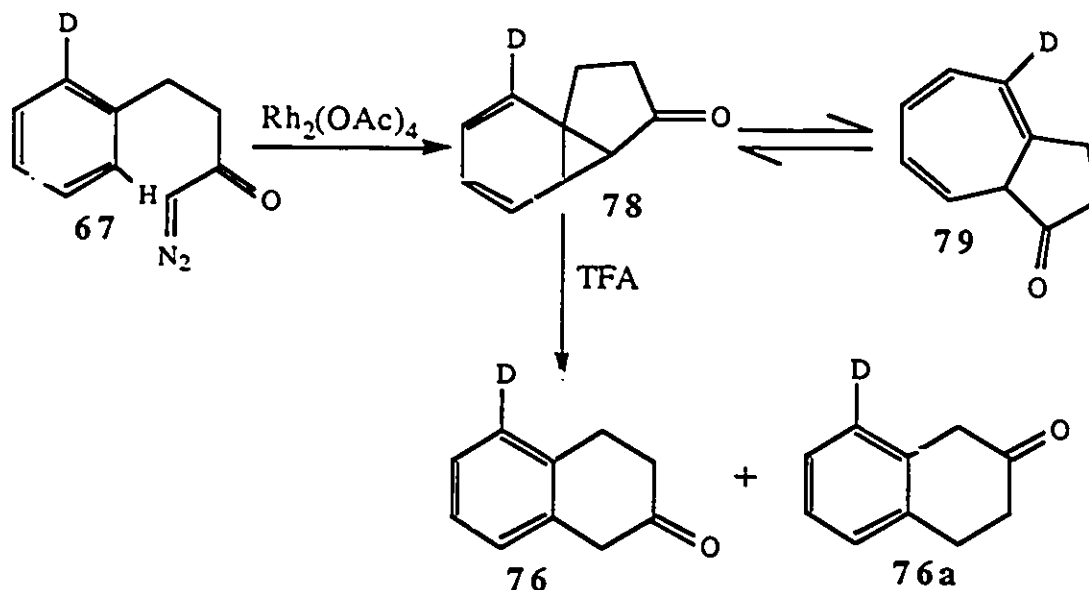

After this unexpected result, when we re-examined the 2-hydroxy furan 59 prepared by Hrytsak and found that in this case too that the deuterium was located at two different positions ( $\delta = 7.43, 7.30, 1:2.1$ ) Comparison of the  $^1\text{H}$ NMR and deuterium NMR allowed us to show that deuterium was located at the C<sub>4</sub> and C<sub>7</sub> positions of the aromatic ring. The deuterium NMR spectrum of compound 74 showed only one signal.

These results clearly eliminate the metallocycle 60 as a potential intermediate in the conversion of 57 to 59, because such a pathway would not lead to deuterium scrambling in the aromatic ring of the products. The results are consistent with either the norcaradiene-cycloheptatriene pathway or the electrophilic aromatic substitution mechanism.

<sup>1</sup>H NMR Spectrum of compound 76

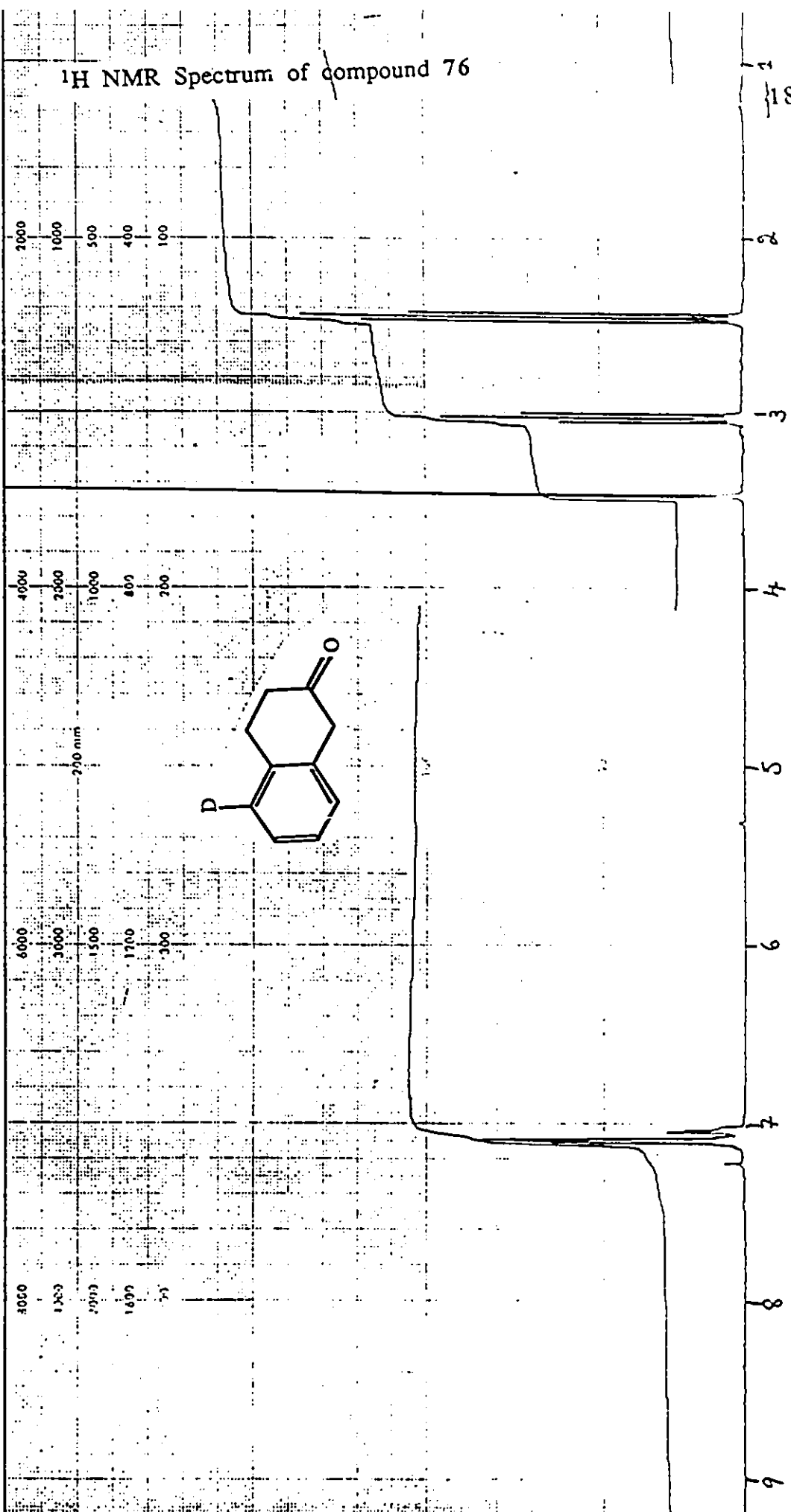

186

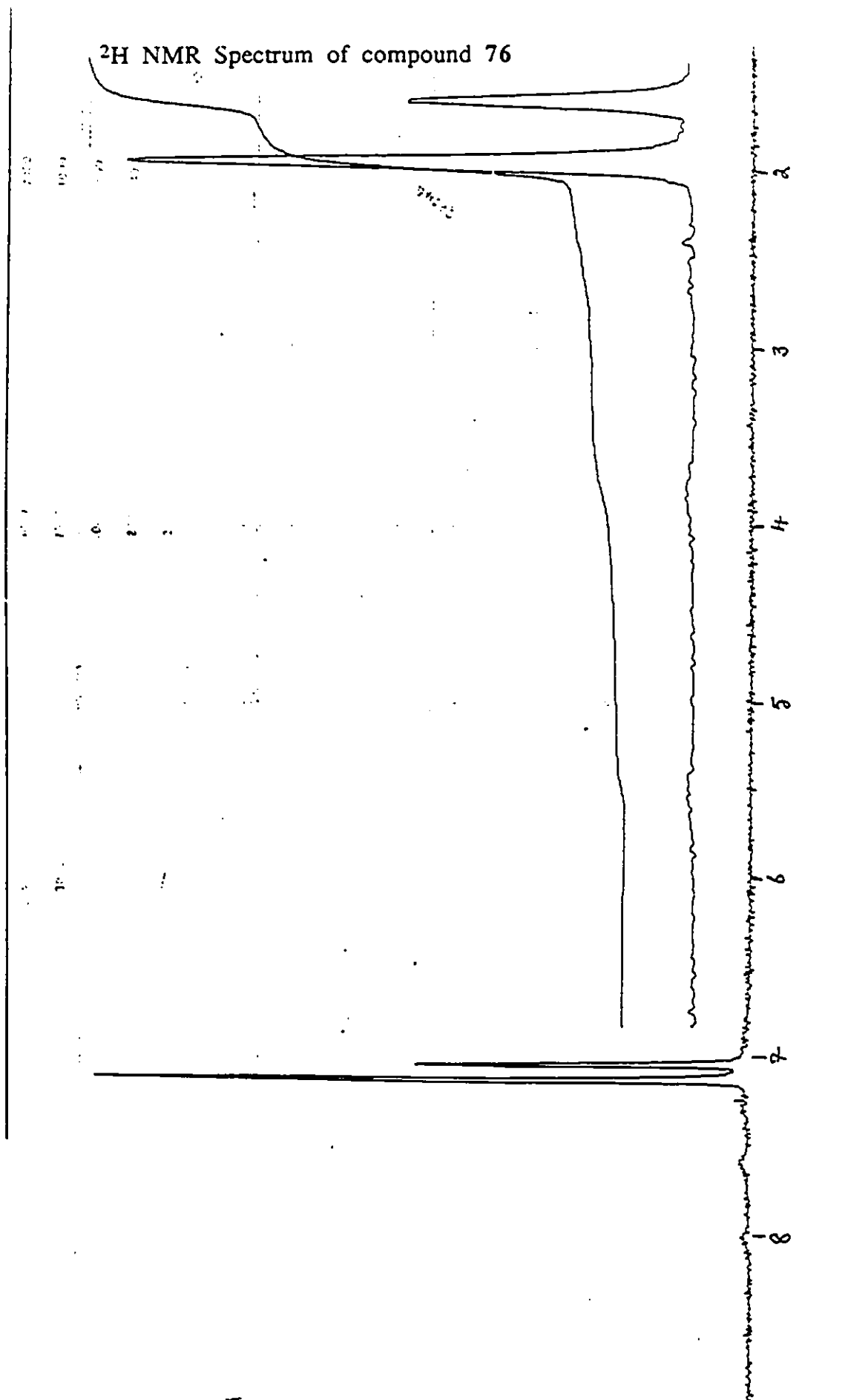

<sup>1</sup>H NMR Spectrum of compound 59

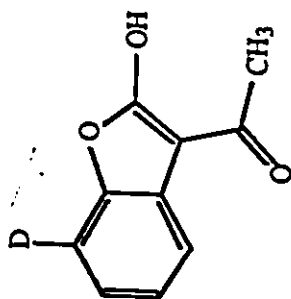

73.04  
3

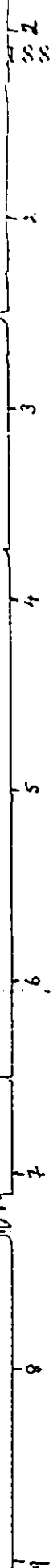

<sup>2</sup>H NMR Spectrum of compound 59

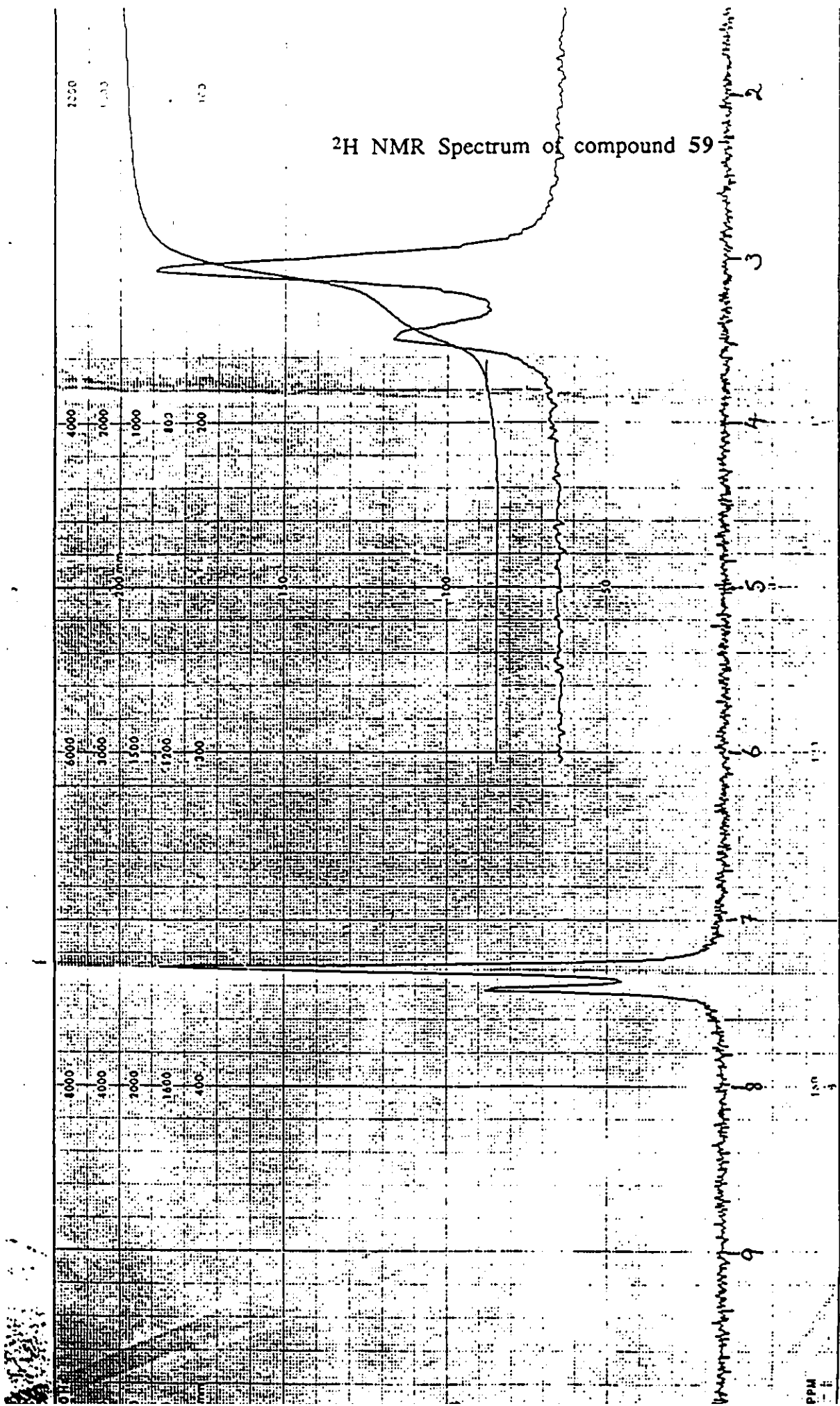

However in order to fit both the H/D isotope effects and the deuterium scrambling in the aromatic ring we find it necessary to propose that the rate determining step for the overall transformation to the ring-fused products is the final rearomatization step and that this step is preceded by series of very rapid equilibrations between a number of carbocations. These ideas are illustrated using monodeuterated substrate **67**.

This compound is known to first form the norcaradiene **78** or its cycloheptatriene equivalent **79**.<sup>16</sup> Protonation of the deuterated norcaradiene, **78**, followed by ring opening could lead to either the symmetrical spiro intermediate **80**, or the bicyclic cation **81**. These intermediates can interconvert via a simple 1,2 shift of the vinylic carbon or by reversal to **78**. The isomeric bicyclic cation **82** is also accessible from the key spirocation via a 1,2 alkyl shift. Both the isotope effects and the deuterium distribution in the product are explained if the interconversion between ions **80**, **81** and **82** is rapid compared to the loss of H<sup>+</sup> or D<sup>+</sup> from **81** or **82**. (Scheme 9)

Scheme 9

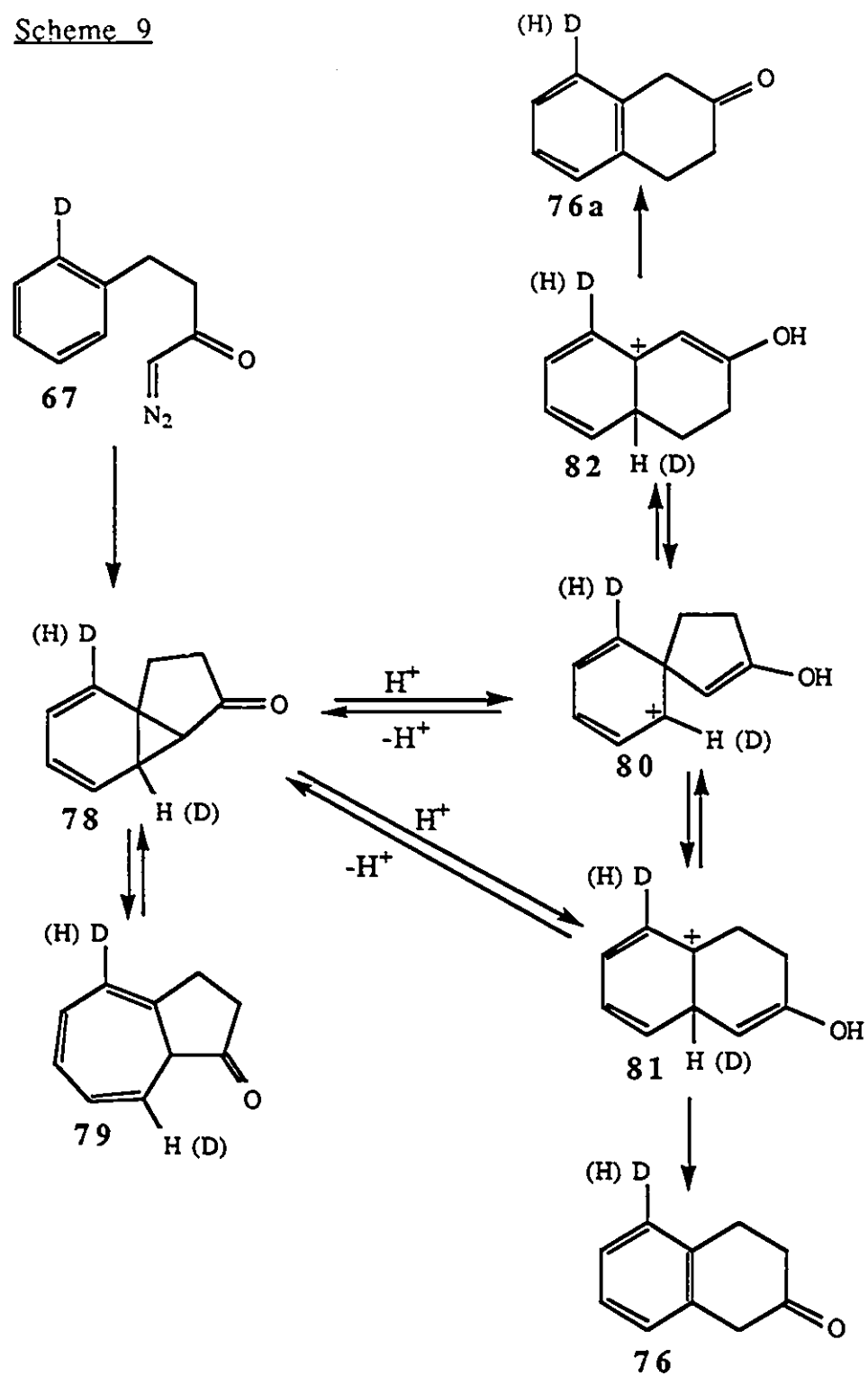

In the case of reactions leading to the fused 6,5-membered ring products 72, 74 and 76, a norcaradiene intermediate is less likely to include a highly strained [2,1,0] bicyclopentane ring system. (For example 62.) In these examples an alternate pathway involving electrophilic substitution could also accommodate both the isotope effects and the distribution of products. Electrophilic attack of the carbenoid on the aromatic ring leads to the intermediate 83. In order to account for deuterium appearing in two different positions in the aromatic ring we propose that 83 undergoes a 1,2 alkyl shift to form the symmetrical spirocation intermediate 84. This can lose either H<sup>+</sup> or D<sup>+</sup> to give 59 which bears the remaining deuterium ortho to the oxygen substituent, or rearrange by migration of the ester group to the isomeric cation 86. Loss of H<sup>+</sup> (D<sup>+</sup>) from 86 affords 59a bearing the retained D atom meta to the ester grouping. Again a very rapid equilibration between 83 and 86 via the intermediate spiro derivative 84. (Scheme 10)

Scheme 10

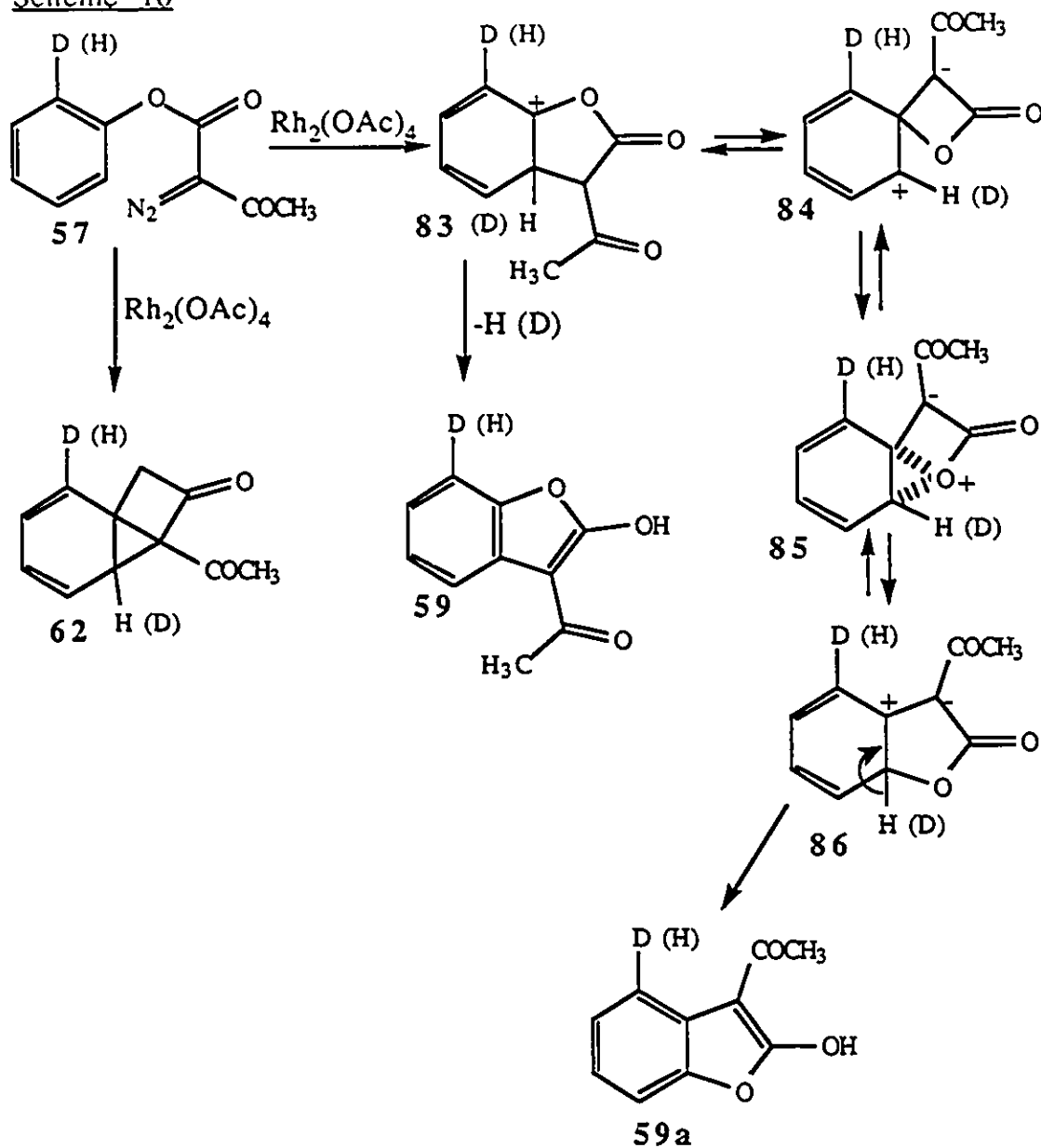

While the above proposals appear capable of explaining both the deuterium distribution in the products 76(76a) and 59(59a)

and the deuterium isotope effects they also lead to unrealized other predictions.

In principle, the deuterium atom can be considered as an aromatic substituent, and thus substrates bearing other substituents on the aromatic ring should likewise give isomeric products, that is products in which that such substituent appear at the positions analogous to the deuterium in 76 and 76a, unless the substituent biases the reaction pathway toward one of the two isomers.

The "ideal" substituent might be a simple  $\text{CH}_3$  group since such a substituent has only a small  $\sigma$  value and thus should not effect significantly the relative stability of the various cations in the above schemes. A methoxy substituent on the other hand has a large effect on the stability of adjacent carbocations and thus one of the two products might be strongly favoured. Unfortunately a careful re-examination of all of the NMR spectra available, both from this and the Hrytsaks' studies failed to reveal the presence of the second regioisomer in any of the cases. ( $\text{CH}_3$ ,  $\text{OCH}_3$ , Br as ortho or meta substituents)

In particular the *m*-methyl substituted diazoester 87 gave the product 88 in 93% yield. Only one sharp aromatic  $\text{CH}_3$  signal was observed.

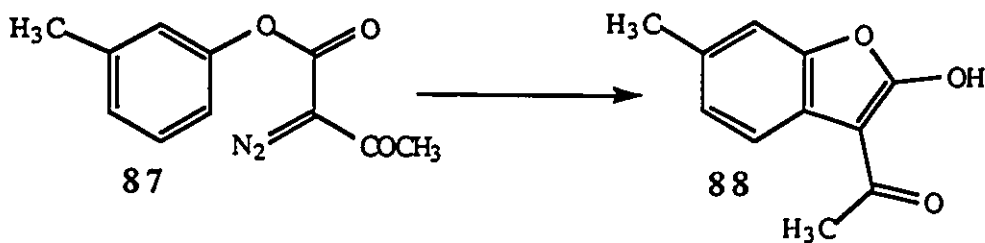

For the reaction of the meta methoxy isomer 89 one might have predicted the formation of the product 93 rather than 94 if equilibration between the cations analogous to 83 and 86, via the spiro derivative 84 is rapid. An NOE experiment on the product, obtained in 95% yield, showed that the irradiation of the acetyl peak at  $\delta=2.04$  gave a significant peak enhancement for the doublet at  $\delta=7.19$  ( $J=8$  Hz). Only the non-rearranged compound 94 (as originally assigned by Hrytsak) is compatible with this. In the alternate structure 93 the H which is closest to the acetyl group should appear as a singlet or narrowly spaced doublet.

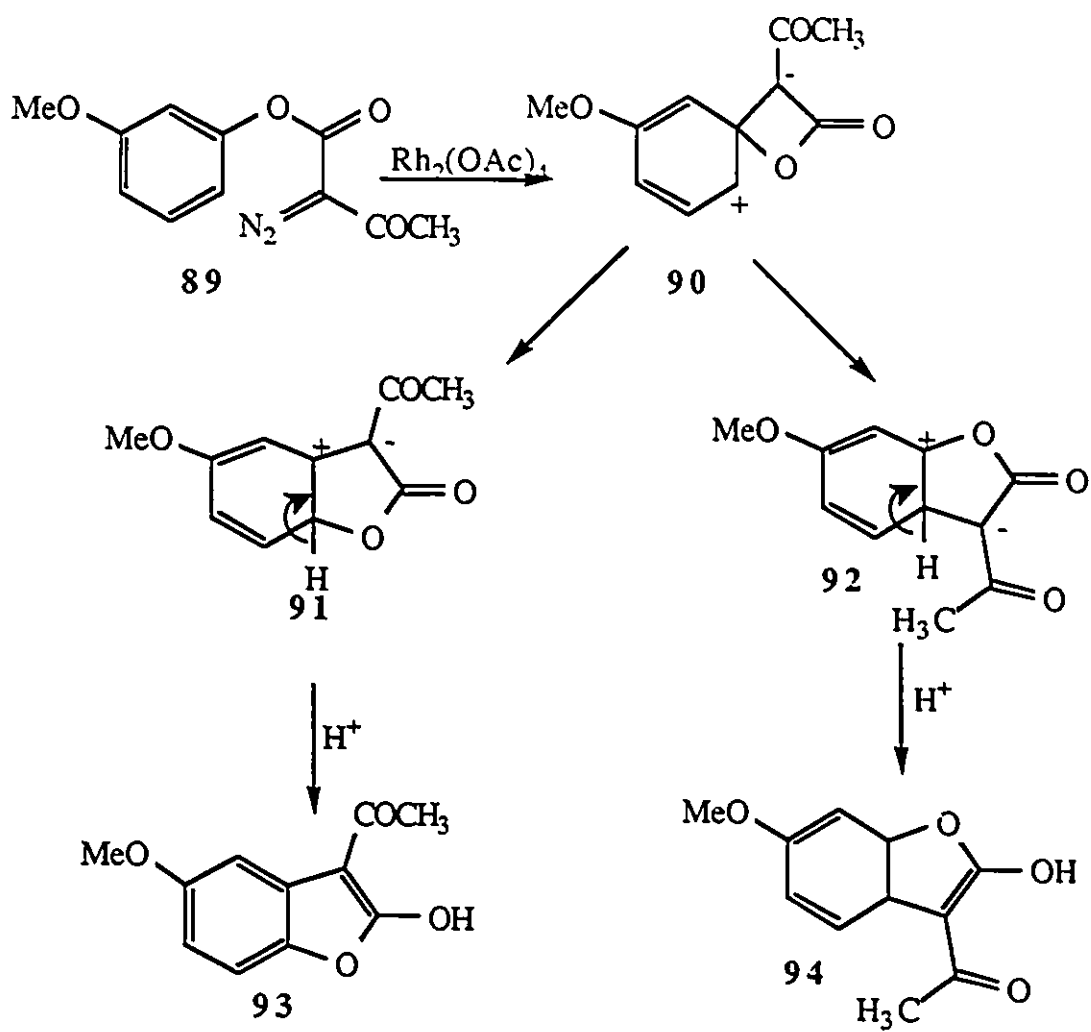

The deuterium isotope effect studies described in this chapter have not allowed us to come to a definitive conclusion concerning the mechanism of the intramolecular reaction between rhodium carbenoids and aromatic rings. It does appear that the rate determining step is not the first step otherwise a small isotope effect should have been observed. A determination of the isotope effect for the formation of the cycloheptatriene **79** from **67** might help to verify the above conclusions. An explanation for the unexpected deuterium scrambling in the aromatic ring and the failure of a meta methyl substituent to give a similar result appears to require further work.

## Experimental Section

### Deuterated benzyl alcohol, 64

Sodium hydride (0.26 g) was washed twice with hexane at -78°C under a nitrogen atmosphere. A solution of 5.1 g of o-bromobenzyl alcohol (27.2 mmol) in 50 mL of dry THF was added. The reaction mixture was allowed to warm up to room temperature and was stirred for 1.5 h. The reaction mixture was cooled to -100°C and 17.5 mL (46.3 mmol) of a 2.5 M solution of n-BuLi was added. The resulting mixture was allowed to stir at -100°C for 5 minutes after which time 6 mL of D<sub>2</sub>O was added. Stirring was continued for 15 minutes at -100°C and the reaction mixture was gradually allowed to warm up to room temperature. After a final 15 minutes of stirring the reaction mixture was quenched with saturated NH<sub>4</sub>Cl solution, extracted with ether, dried (MgSO<sub>4</sub>), and evaporated to give 3.4 g of an oil. The crude product was purified by chromatotron using 4:1 hexane:ethyl acetate as a solvent system to afford 2.32 g (80%) of 64, an oil.

### Deuterated β-sulfone ester, 68

To a solution of ethyl mercaptoacetate (3 g, 25.5 mmol) and deuterated benzylic alcohol 64 (2.32, 21.2 mmol) in CH<sub>2</sub>Cl<sub>2</sub> (2 mL/mmol of alcohol) under N<sub>2</sub> at room temperature was added 0.5 equivalents of powdered zinc iodide (3.4 g, 10.6 mmol). The mixture was stirred for 45 min and then washed with water. The organic

phase was dried over  $\text{MgSO}_4$  and evaporated to give 3.6 g (80%) of crude benzylic sulfide. It was used for the next step without further purification and characterization.

A solution of sulfide (3.6 g, 17 mmol) in  $\text{CH}_2\text{Cl}_2$  (2 mL/ mmole) was cooled in an ice bath, and m-chloroperoxybenzoic acid (8.9 g, 2.4 equiv) was added in small portions. The mixture was stirred at  $0^\circ\text{C}$  for 2 h following the addition of the peracid, whereupon TLC analysis revealed that all of the starting sulfide had been consumed. The mixture was filtered to remove the by-product m-chlorobenzoic acid, and the filtrate was successively washed with 10%  $\text{Na}_2\text{SO}_3$  then 5%  $\text{NaHCO}_3$  solutions and then dried over  $\text{MgSO}_4$  and evaporated to give crude sulfones and they were purified by silica gel chromatography afforded 2.6 g (62%) of pure sulfone of mp  $77^\circ\text{C}$ .

$^1\text{H}$  NMR ( $\text{CDCl}_3$ )  $\delta$  7.44(m, 4H), 4.51(s, 2H), 4.30(q, 2H,  $J=7.2$  Hz), 3.75(s, 2H), 1.34(t, 3H,  $J=7.2$  Hz); IR ( $\text{CHCl}_3$ )  $\text{cm}^{-1}$  1330, 1120; ei-MS  $m/e$  92( $\text{M}^+-151$ , 100%)

#### Deuterated $\alpha$ -diazo- $\beta$ -sulfone ester, 65

Sodium hydride (0.35 g) was washed twice with hexanes at  $-78^\circ\text{C}$  under nitrogen atmosphere. A solution of deuterated sulfone (1.4 g, 5.76 mmol) in dry THF and tosyl azide (1.36 g, 6.9 mmol) were added sequentially at  $-78^\circ\text{C}$ . The reaction mixture was allowed to warm to room temperature. Stirring was maintained at room temperature for 3-5 minutes and then the reaction mixture was quenched with saturated  $\text{NH}_4\text{Cl}$  solution, extracted with ether, dried and evaporated. The crude diazo compound thus obtained was further purified by chromatography on silica gel using 3:1

hexane:ethyl acetate as an eluant afforded 0.63 g (41%) of pure diazo compound, an oil.

$^1\text{H}$  NMR ( $\text{CDCl}_3$ )  $\delta$  7.36(m, 4H), 4.57(s, 2H), 4.35(q, 2H,  $J=7.1\text{Hz}$ ), 1.35(t, 3H,  $J=7.1\text{ Hz}$ ); IR (neat)  $\text{cm}^{-1}$  2120, 1710, 1340; ei-ms  $m/e$  195( $\text{M}^+-74$ , 15%), 194( $\text{M}^+-75$ , 6%), 131( $\text{M}^+-138$ , 15%), 130( $\text{M}^+-139$ , 68%), 92( $\text{M}^+-177$ , 100%), 91( $\text{M}^+-178$ , 29%).

#### Rhodium carboxylate catalyzed cyclization of $\alpha$ -diazosulfone, 72

A solution of the diazo sulfone (0.12 g, 0.44 mmol) in dry  $\text{CH}_2\text{Cl}_2$  (4 mL/mmol) was stirred at room temperature and treated with 5 mole % of rhodium acetate in one portion. Gas evolution occurred slowly. The progress of the reaction was monitored by TLC. When the reaction was judged to be complete, the solution was filtered through a cotton plug and the solvent was evaporated. The desired bicyclic sulfone was purified via silica gel chromatography by using 4:1 hexane: ethyl acetate as a solvent system afforded 45 mg (42%) of 72 as a white solid of mp 184-185°C.

$^1\text{H}$  NMR ( $\text{CDCl}_3$ )  $\delta$  7.38(m, 3H), 5.07(s, 1H), 4.59(d, 1H,  $J=15.3\text{ Hz}$ ), 4.30(q, 2H,  $J=7.2\text{ Hz}$ ), 1.32(t, 3H,  $J=7.2\text{ Hz}$ ); IR ( $\text{CHCl}_3$ )  $\text{cm}^{-1}$  1740, 1340; ei-MS  $m/e$  241( $\text{M}^+$ , 39%), 177( $\text{M}^+-64$ , 43%), 176( $\text{M}^+-65$ , 14%), 149( $\text{M}^+-92$ , 100%)

Deuterated benzyl bromide, 69

Deuterated benzyl alcohol (2.27 g, 21 mmol) was added to a solution of HBr (8.4 g, 104 mmol) in 25 mL of  $\text{CHCl}_3$ . The reaction mixture was stirred at room temperature overnight. The mixture was then gently refluxed at  $\sim 50^\circ\text{C}$  for 30 minutes, at which point TLC indicated the disappearance of the starting material. To the reaction mixture 15 mL of  $\text{CH}_2\text{Cl}_2$  was added. The organic phase was washed with 5% aqueous  $\text{NaHCO}_3$ , dried ( $\text{MgSO}_4$ ), and evaporated to give 2.71 g (76%) of **69**, an oil. The product was used for the next step without further purification.

Deuterated phenylacetic acid, 70

To a solution of deuterated benzyl bromide, **69** (2.71 g, 15.7 mmol) in 15 mL of DMF was added 3.08 g (63 mmol) of NaCN. The mixture was heated at reflux for 45 minutes and then cooled to room temperature. After addition of 15 mL of water, the mixture was extracted with EtOAc. The organic layer was washed with brine, dried ( $\text{MgSO}_4$ ), and evaporated to give 2.02 g of crude product. A peak in the IR spectrum at  $2260\text{ cm}^{-1}$  indicated that conversion of benzyl bromide to benzyl cyanide had taken place. The crude benzyl cyanide, an oil, was used for the next step without further purification.

The crude deuterated benzyl cyanide (2.02 g, 17.2 mmol) was added to a mixture of  $\text{H}_2\text{SO}_4$  and  $\text{CH}_3\text{COOH}$  in water (4 mL). The reaction mixture was heated at reflux for 2 h and cooled to room temperature. After addition of 5 mL of water, the mixture was extracted with ethyl acetate (2X10 mL). Finally, the organic layer

was extracted into 10% NaOH, the basic extract was acidified with 10% HCl, and the deuterated phenylacetic acid was re-extracted into ethyl acetate. The ethyl acetate layer was washed with saturated aqueous NaCl, dried (MgSO<sub>4</sub>), and evaporated to give 1.35 g (62.5% for two steps) of acid as a white solid of mp 77°C.

<sup>1</sup>H NMR (CDCl<sub>3</sub>) δ 7.3(s, 4H), 3.62(s, 2H); IR (CHCl<sub>3</sub>) cm<sup>-1</sup> 2500-3500 (br), 1715; ei-ms m/e 137(M<sup>+</sup>, 32%), 136(M<sup>+</sup>-1, 5.7%), 92(M<sup>+</sup>-45, 100%), 91(M<sup>+</sup>-46, 25%).

#### Deuterated α-diazo ketone, 66

The mixture of deuterated phenyl acetic acid, 70, (1.35 g, 9.8 mmole) and PCl<sub>3</sub> (0.64 mL, 4.9 mmol) was gently heated over a boiling water bath under a nitrogen atmosphere 1 h. Benzene (10 mL) was added to the reaction mixture. The organic layer was separated, dried, and evaporated to give 0.93 g (60%) of acid chloride.

To a solution of diazomethane (18 mmol, 0.75 g) in 54 mL of ether, 0.93 g (6 mmol) of deuterated phenylacetyl chloride in 10 mL of anhydrous ether was added dropwise. The mixture was left at 12°C overnight. After evaporating the solvent, 0.97 g of crude product was obtained. The crude product was purified by chromatotron using 5:1 hexane:ethyl acetate as a solvent system to provide 0.5 g (52%) of 66, an oil.

<sup>1</sup>H NMR (CDCl<sub>3</sub>) δ 7.16(s, 4H), 4.96(s, 1H), 3.48(s, 2H); IR (neat) cm<sup>-1</sup> 2120, 1640; ei-ms m/e 133(M<sup>+</sup>-28, 9.6%), 132(M<sup>+</sup>-29, 7.4%), 105(M<sup>+</sup>-56, 83%), 104(M<sup>+</sup>-57, 33%), 92(M<sup>+</sup>-69, 100%).

Rhodium carboxylate catalyzed cyclization of  $\alpha$ -diazoketone, 74

The diazo ketone (50 mg, 0.3 mmol) was dissolved in 5 mL of dry  $\text{CH}_2\text{Cl}_2$  and the solution was stirred at room temperature. A small amount of rhodium (II) trifluoroacetate was added in one portion. After 1 h, TLC analysis showed that the reaction was complete. The solution was filtered through a cotton plug and evaporated to give 64 mg of crude product. The material was purified by chromatotron using hexane:ethyl acetate as an eluant to afford 26 mg (63%) of 74 as a white solid of mp  $52^\circ\text{C}$ .

$^1\text{H}$  NMR ( $\text{CDCl}_3$ )  $\delta$  7.26(m, 3H), 3.55( s, 4H); IR ( $\text{CHCl}_3$ )  $\text{cm}^{-1}$  1750, 2898, 3020; ei-ms m/e 133( $\text{M}^+$ , 44%), 132( $\text{M}^+-1$ , 8%), 105( $\text{M}^+-28$ , 100%), 104( $\text{M}^+-29$ , 41%).

Deuterated 3-phenylpropionic acid (Dihydro cinnamic acid), 71

To a mixture of methyl (triphenylphosphoranylidene)acetate ("wittig reagent", 16 g, 47 mmol) in 100 mL of ethyl acetate was added 4.2 g (0.019 mmol) of deuterated benzyl bromide. The mixture was heated at reflux for 6 h. and cooled to room temperature. The solvent was evaporated. To the residue, 3.30 g (58.9 mmol) of KOH in 70 mL of aqueous methanol (35 mL MeOH + 35 mL H<sub>2</sub>O) was added. The reaction mixture was refluxed 6 h. and cooled to room temperature. The mixture was extracted with ethyl acetate and the solvent was evaporated. The residue was dissolved in 40 mL of THF. Hexane (20 mL) was added and triphenylphosphine oxide was filtered off to give 3.7 g (91%) of ester. The ester was used for the next step without further purification.

The ester (3.7 g, 22.4 mmol) was added to 1.4 g of KOH (25 mmol) in 28 mL of aqueous methanol (14 mL H<sub>2</sub>O + 14 mL MeOH) at room temperature. The reaction mixture was gently refluxed over a period of 12 h and cooled to room temperature. The reaction mixture was acidified, extracted with EtOAc, dried and evaporated to give 2.3 g of acid (69%) of mp 47°C.

<sup>1</sup>H NMR (CDCl<sub>3</sub>) δ 7.25(m, 4H), 2.95(t, 2H, J=7.45), 2.67(t, 2H, J=7.45); IR (CHCl<sub>3</sub>) cm<sup>-1</sup> 3500-2500 (br), 1720, 1230; ei-ms m/e 151(M<sup>+</sup>, 40.3%), 106(M<sup>+</sup>-45, 40.3%), 105(M<sup>+</sup>-46, 36%), 104(M<sup>+</sup>-47, 20%), 92(M<sup>+</sup>-59, 100%), 91(M<sup>+</sup>-60, 25%).

Deuterated α-diazo ketone, 67

3-Phenylpropionic acid, 71, (1.6 g, 10.5 mmol) was added to 1.96 mL (26.5 mmol) of thionyl chloride at room temperature. The

reaction mixture was gently refluxed over a period of 2.5 h and cooled to room temperature. The solvent was evaporated to afford 1.9 g of acid chloride. A peak in the IR spectrum at  $1800\text{ cm}^{-1}$  indicated that conversion of the acid to the acid chloride had taken place. The acid chloride was used for the next step without further purification.

To a solution of a diazomethane (28 mmol, 1.12 g) in 80 mL of ether was added 1.9 g of (1.2 mmol) of deuterated 3-aryl propionylchloride in 25 mL of anhydrous ether. The mixture was left at  $12^{\circ}\text{C}$  overnight. After evaporating the solvent, 2.1 g of crude product was obtained. This material was purified by chromatotron using 4:1 hexane:ethyl acetate as the solvent system to give 1.4 g (75.6%) of 57, an oil.

$^1\text{H NMR}$  ( $\text{CDCl}_3$ )  $\delta$  7.16(s, 4H), 5.06(s, 1H), 2.17(m, 4H); IR (neat)  $\text{cm}^{-1}$  1650, 2120, 2941, 3105; ei-ms m/e 147( $\text{M}^+-28$ , 10%), 146( $\text{M}^+-29$ , %), 119( $\text{M}^+-56$ , 78%), 118( $\text{M}^+-57$ , 61%), 105( $\text{M}^+-70$ , 93%), 92( $\text{M}^+-83$ , 100%).

#### Rhodium carboxylate catalyzed cyclization of $\alpha$ -diazoketone, 76

The diazoketone (0.6 g, 3.5 mmol) was dissolved in dry  $\text{CH}_2\text{Cl}_2$  and the solution was stirred at room temperature. A small amount of rhodium (II) acetate was added in one portion. After stirring overnight, TLC analysis showed that the reaction was complete. The solution was filtered through a cotton plug and was evaporated to give 0.5 g of crude product. The residue was purified by chromatotron using 4:1 hexane:ethyl acetate as an eluant to afford 0.36 g (70 %) of 2-tetralone, 76, as an oil.

$^1\text{H}$  NMR ( $\text{CDCl}_3$ )  $\delta$  7.08(m, 3H), 3.47(s, 2H), 3.03(t, 2H,  $J=6.8$  Hz),  
2.45(t, 2H,  $J= 6.8$  Hz); IR (neat)  $\text{cm}^{-1}$  1715, 2990, 3030; ei-ms  $m/e$   
147( $\text{M}^+$ , 49%), 146( $\text{M}^+-1$ , 27%), 105( $\text{M}^+-42$ , 100%), 104( $\text{M}^+-43$ , 66%)

## Appendix 1

### Calculation of kH/kD for 1,3-dihydrothiophene-2,2-dioxide

#### A) Deuterated benzyl alcohol

A cluster of peaks present at  $m/e=107-110$  for the deuterated benzyl alcohol, used in the synthesis of deuterated 1,3-dihydrothiophene-2,2-dioxide, did not allow us to determine the percentage of mono-deuterated material present in the sample in a straight-forward manner. A method of trial calculations using deuterated values between 75% and 100% gave a good mathematical match to the observed mass spectroscopy data at 91% mono-deuterated material. Table I shows the mass spectrometry data for monodeuterated and non-deuterated benzyl alcohol. Table II presents a calculation for a 91% monodeuterated material and 9% non-deuterated mixture using the data for the non-deuterated benzyl alcohol from Table I to predict the relative abundance of the mass spectroscopy peaks between  $m/e = 107-110$ . The correspondance between the observed normalized data (in brackets) and the calculated values is acceptable.

**Table I**

m/e	Observed relative abundance in MS			
	non deuterated <sup>a</sup>		deuterated <sup>b</sup>	
	benzyl alcohol		benzyl alcohol	
110	0.1	(1.4)	6.0	(7.6)
109	5.8	(8.2)	78.6	(100)
108	70.4	(100)	69.4	(88)
107	53.5	(76)	21.0	(26.7)
106	15.6	(22)	5.0	(6.3)

(a) Values in parentheses were obtained by normalizing the M<sup>+</sup> peak at m/e=108 to be 100%.

(b) Values in parentheses were obtained by normalizing the M<sup>+</sup> peak at m/e=109 to be 100%.

**Table II**

Sample calculation for 91% monodeuterated (9% non-deuterated) material

m/e	Contribution from	Contribution from	total <sup>a</sup> contribution
	deuterated	non-deuterated	
	benzyl alcohol	benzyl alcohol	
110	$0.91 \times 8.2 = 7.4$	$0.09 \times 0.14 = 0.012$	7.41 (8.17)
109	$0.91 \times 100 = 91$	$0.09 \times 8.2 = 0.738$	91.7 (100)
108	$0.91 \times 76 = 69.1$	$0.09 \times 100 = 9.0$	78.1 (85)
107	$0.91 \times 22 = 20.0$	$0.09 \times 76 = 6.84$	26.8 (29)

(a) Values in parentheses were obtained by normalizing the M<sup>+</sup> peak at m/e=109 to be 100%.

B) 1,3-dihydrothiophene-2,2-dioxide (D-content)

$$\begin{aligned} \text{Observed ratio for mass 241/ 240} &= 61.2:19 \\ &= 100:31 \end{aligned}$$

$$\text{Calculated M+1 of 241} = 14.3$$

$$\begin{aligned} \text{Corrected for M+1 of 241} &= 100-(31 \times 0.143):31 \\ &= (100-4.4):31 \\ &= 75.5\% \text{ D} \end{aligned}$$

C) Calculated kH/ kD Effect

$$\text{From benzyl alcohol (91\%-75.5\%)} = 15.5\% \text{ loss of D}$$

$$\begin{aligned} \text{So kH/kD} &= 75.5/15.5 \\ &= 4.9 \end{aligned}$$

## Appendix 2

### Calculation of kH/kD for 2-Indanone

#### A) Deuterated benzyl alcohol

A calculation similar to that shown in Appendix 1 was necessary for determining the amount of mono-deuterated benzyl alcohol used in making 2-indanone. A method of trial calculations using deuterated values between 75% and 100% gave a good mathematical match to the observed mass spectroscopy data at 97% mono-deuterated material. Table III shows the mass spectroscopy data for deuterated and non-deuterated benzyl alcohol. Table IV presents a calculation for 97% deuterated material (3% non-deuterated), using the data for the non-deuterated benzyl alcohol from Table III to predict the relative abundance of the mass spectroscopy peaks between  $m/e = 107-110$ .

**Table III**

m/e	Observed relative abundance in MS	
	non deuterated <sup>a</sup> benzyl alcohol	deuterated <sup>b</sup> benzyl alcohol
110	0.1 (0.14)	6.2 (7.2)
109	5.8 (8.2)	85.2 (100)
108	70.4 (100)	66.5 (78)
107	53.5 (76)	12.9 (15)
106	15.6 (22)	4.7 (5.5)

(a) Values in parantheses were obtained by normalizing the

M<sup>+</sup> peak at m/c=108 to be 100%.

(b) Values in parantheses were obtained by normalizing the M<sup>+</sup> peak at m/c=109 to be 100%.

**Table IV**

Sample calculation for 97% monodeuterated (3% non-deuterated) material

m/e	Contribution from deuterated	Contribution from non-deuterated	total <sup>a</sup> contribution
	benzyl alcohol	benzyl alcohol	
110	0.97 x 8.2 = 7.95	0.03 x 0.14 = 0.004	7.95 (8.1)
109	0.97 x 100 = 97.0	0.03 x 8.2 = 0.24	97.2 (100)
108	0.97 x 76 = 73.7	0.03 x 100 = 3.0	76.7 (78.9)
107	0.97 x 22 = 21.3	0.03x 76 = 2.28	23.5 (24)

(a) Values in parantheses were obtained by normalizing the M<sup>+</sup> peak at m/c=109 to be 100%.

**B) 2-Indanone (D-content)**

$$\begin{aligned} \text{Observed Ratio of Mass 133/ 132} &= 44.6:8.5 \\ &= 100:19.3 \end{aligned}$$

$$\text{Calculated M+1 of 132} = 12.3$$

$$\begin{aligned}
 \text{Corrected for M+1 of 146} &= 100 - (19.3 \times 0.123):19.3 \\
 &= (100 - 2.37):31 \\
 &= 83.4\% \text{ D}
 \end{aligned}$$

From the  $^2\text{DNMR}$ :

$$\text{Amount of D present on the aromatic ring:aliphatic ring} = 114:9$$

$$\begin{aligned}
 \text{Amount of D present on the aromatic ring} &= 83.4 \times 114/123 \\
 &= 77\%
 \end{aligned}$$

$$\begin{aligned}
 \text{Amount of D present on the aliphatic ring} &= 83.4 \times 9/123 \\
 &= 6\%
 \end{aligned}$$

### C) Calculated kH/ kD Effect

$$\begin{aligned}
 \text{From benzyl alcohol (97\%-77\%)} &= 20\% \text{ loss of D} \\
 \text{So kH/kD} &= 77/20 \\
 &= 3.85
 \end{aligned}$$

### Appendix 3

#### Calculation of kH/kD for 2-Tetralone

##### A) Deuterated diazoketone

A cluster of peaks present at  $m/e=88-93$  ( $92=M^+-83$ ) for the deuterated diazoketone did not allow us to determine the percentage of mono-deuterated material present in the sample in a straight-forward manner. A method of trial calculations using deuterated values between 75% and 100% gave a good mathematical match to the observed mass spectroscopy data at 81% mono-deuterated material. Table V shows the mass spectroscopy data for deuterated and non-deuterated benzyl alcohol. Table VI presents a sample calculation for 81% deuterated material (19% non-deuterated), using the data for the non-deuterated benzyl alcohol from Table V to predict the relative abundance of the mass spectroscopy peaks between  $m/e = 88-93$ .

Table V

m/e	Observed relative abundance in MS	
	non deuterated <sup>a</sup> diazoketone	deuterated <sup>b</sup> diazoketone
88	0.8	0.7
89	7.7	4.8
90	14.6	10.3
91	100	37.8
92	10.6	100
93	--	8.6

**Table VI**

Sample calculation for 81% monodeuterated (19% nondeuterated) material

m/e	Contribution from deuterated diazoketone	Contribution from non-deuterated diazoketone	total <sup>a</sup> contribution
89	$0.81 \times 0.8 = 0.65$	$0.19 \times 7.7 = 1.46$	2.11 (2.53)
90	$0.81 \times 7.7 = 6.24$	$0.19 \times 14.6 = 2.77$	9.01 (10.8)
91	$0.81 \times 14.6 = 11.8$	$0.19 \times 100 = 19.0$	30.8 (37.1)
92	$0.81 \times 100 = 81.0$	$0.19 \times 10.6 = 2.0$	83.0 (100)
93	$0.81 \times 10.6 = 8.58$	--	8.58 (10.3)

(a) Values in parantheses were obtained by normalizing the M<sup>+</sup> peak at m/c=92 to be 100%.

**B)2-Tetralone (Constant D-content)**

$$\begin{aligned} \text{Observed Ratio of Mass 147/ 146} &= 49:27 \\ &= 100:55 \end{aligned}$$

$$\text{Calculated M+1 of 146} = 10.9$$

$$\begin{aligned} \text{Corrected for M+1 of 146} &= 100-(55 \times 0.109):55 \\ &= (100-6):55 \\ &= 63\% \text{ D} \end{aligned}$$

C) Calculated kH/ kD Effect

From  $\alpha$ -diazo ketone (82%-63%) = 19% loss of D

So kH/kD = 63/19

= 3.3

## References

1. T. Curtius, *Chem. Ber.*, 1883, 16, 2330.
2. D.S. Wulfman, B. Poling, *In Reactive Intermediates*: R.A. Abramovitch Ed.; Plenum Press: New York, 1980; Vol. 1, 321.
3. (a) M.P. Doyle, *Chem. Rev.*, 1986, 86, 919; (b) G. Mass, *In Topics in Current Chemistry. Organic synthesis, reactions and mechanisms*: Springer Verlag: New York, 1987; Vol. 137, 75.
4. H. Nozaki, S. Moriuti, H. Takaya, K. Noyori, *Tetrahedron Letts.*, 1966, 5239.
5. P. Yates, *J. Amer. Chem. Soc.*, 1952, 74, 5376.
6. A.J. Anciaux, A.F. Noels, A.J. Hubert, P. Teyssie, *J. Org. Chem.*, 1980, 45, 695.
7. T. Aratani, Y. Yonegoshi, T. Nagasae, *Tetrahedron Letts.*, 1977, 2599.
8. H. Nozaki, H. Takaya, S. Moriuti, R. Noyori, *Tetrahedron*, 1968, 24, 3655.
9. R. Noyori, H. Takaya, Y. Nakahishi, *Can. J. Chem.*, 1969, 47, 1242.
10. C.P. Casey, S.W. Polichnowski, A.J. Shusterman, C.R. Jones, *J. Amer. Chem. Soc.*, 1979, 101, 7382.
11. M.P. Doyle, J.H. Griffin, V. Bagheri, R.L. Dorow, *Organometallics*, 1984, 3, 53.
12. A.J. Anciaux, P. Demonceau, A.F. Noels, A.J. Hubert, R. Warin, P. Teyssie, *J. Org. Chem.*, 1981, 46, 873, and references cited therein.
13. M.J. Rosenfeld, B.K. Ravishankar, H. Schechter, *J. Org. Chem.*, 1988, 53, 2699.
14. H.K-W. Hui, H. Schechter, *Tetrahedron Letts.*, 1982, 23, 5115.

15. M.A. McKervey, D.N. Russell, M.F. Twohig, *J. Chem. Soc., Chem. Comm.*, 1984, 491.
16. M.A. McKervey, S.M. Tuladhar, M.F. Twohig, *J. Chem. Soc., Chem. Comm.*, 1984, 129.
17. A. Padwa, T.J. Wisnieff, E.J. Walsh, *J. Org. Chem.*, 1989, **54**, 299.
18. K. Nakatani, *Tetrahedron Letts.*, 1987, **28**, 165.
19. M. Matsumoto, N. Watanabe, H. Kobayashi, *Heterocycles*, 1987, **26**, 1479.
20. M. Hrytsak, N. Etkin, T. Durst, *Tetrahedron Letts.*, 1986, **27**, 5679.
21. S.D. Babu, M.D. Hrytsak, T. Durst, *Can. J. Chem.*, 1989, **67**, 1071.
22. M. Hrytsak, T. Durst, *J. Chem. Soc., Chem. Comm.*, 1987, 1151.
23. N. Etkin, S.D. Babu, C.J. Fooks, T. Durst, *J. Org. Chem.*, 1990, **55**, 1093.
24. M.P. Doyle, M.S. Shanklin, S.M. Oon, H.Q. Pho, F.R. Van der Heide, W.R. Veal, *J. Org. Chem.*, 1988, **53**, 3384.
25. D.F. Taber, R.E. Ruckle, *J. Amer. Chem. Soc.*, 1986, **108**, 7686.
26. D.F. Taber, E.H. Petty, K. Raman, *J. Amer. Chem. Soc.*, 1985, **107**, 196.
27. G. Stork, K. Nakatani, *Tetrahedron Letts.*, 1988, **29**, 2283.
28. J. Adams, M.A. Poupart, L. Grenier, R. Frenette, *Tetrahedron Letts.*, 1989, **30**, 1749.
29. D.B. Denney, P. Klemchuck, *J. Amer. Chem. Soc.*, 1958, **80**, 6014.
30. L.H.P. Gommans, L. Main, B.K. Nicholson, *J. Chem. Soc., Chem. Comm.*, 1986, 12.

## CLAIMS to ORIGINAL RESEARCH

1. (L)-Phenylalanine was synthesized in three steps from the Sharpless epoxidation product 22.
2. Enantiomerically pure 2-phenylpropionic acid, 2-naphthylpropionic acid, and Ibuprofen were synthesized in good yields in two steps from Sharpless epoxidation products.
3. Reaction of racemic 2-phenylpropionyl chloride with quinine gave a 4:1 diastereomer ratio of esters as observed by  $^1\text{H}$  NMR.
4. Treatment of 4-carbethoxy-4,6-dihydrothieno[3,4-b] thiophene 5,5-dioxide, prepared by treatment of the diazo sulfone 29 with rhodium acetate, with varying amounts of *n*-BuLi and methyl iodide resulted in predictable regioselective alkylation.
5. Attempts to trap the thiophene xylylene bearing a carbethoxy group on the xylylene portion with electron rich or electron poor dienophiles failed, but moderate yields of adducts were obtained in trapping experiments between a phenyl substituted thiophene xylylene and electron poor dienophiles such as dimethyl acetylenedicarboxylate, dimethyl fumarate and benzoquinone.

6. Treatment of  $\alpha$ -diazo- $\beta$ -(arylmethylsulfonyl) esters with rhodium acetate afforded 1-carbethoxy-1,3-dihydrobenzo[c]thiophene-2,2-dioxides. An attempt to extend the scope of this reaction to the corresponding furan derivatives failed and unusual furan ring opened products were obtained.

7. Reaction of various  $\alpha$ -diazo- $\beta$ -ketoanilides with rhodium acetate gave 2-hydroxy-3-acetylindoles. When an  $\alpha$ -diazo- $\beta$ -ketoanilide derived from meta-nitroaniline was treated with rhodium acetate it did not form the expected 2-hydroxy-3-acetylindole derivative, but instead formed a  $\beta$ -lactam in very low yield.

8.  $\alpha$ -Diazomalonamide esters, on treatment with rhodium acetate, failed to form the expected 2-hydroxy-3-carbethoxyindoles.

9. Hydrogen deuterium isotope effects ranging from 3.3-4.9 were determined for the formation of 1-carbethoxy-1,3-dihydrobenzo[c]thiophene 2,2-dioxide, 2-indanone, and 2-tetralone via rhodium carbenoid reactions. Scrambling of the deuterium label was observed in the 2-tetralone formation.