

INFORMATION TO USERS

This manuscript has been reproduced from the microfilm master. UMI films the text directly from the original or copy submitted. Thus, some thesis and dissertation copies are in typewriter face, while others may be from any type of computer printer.

The quality of this reproduction is dependent upon the quality of the copy submitted. Broken or indistinct print, colored or poor quality illustrations and photographs, print bleedthrough, substandard margins, and improper alignment can adversely affect reproduction.

In the unlikely event that the author did not send UMI a complete manuscript and there are missing pages, these will be noted. Also, if unauthorized copyright material had to be removed, a note will indicate the deletion.

Oversize materials (e.g., maps, drawings, charts) are reproduced by sectioning the original, beginning at the upper left-hand corner and continuing from left to right in equal sections with small overlaps.

ProQuest Information and Learning
300 North Zeeb Road, Ann Arbor, MI 48106-1346 USA
800-521-0600

UMI[®]



ARCS

**Transition Metal Catalyzed Carbonylations of Vinylsilanes,
Allyl Sulfides and Related Systems**

by

CATHLEEN MARIE CRUDDEN

B. Sc., University of Toronto, 1989
M. Sc., University of Toronto, 1990.

A Thesis Submitted to the School of Graduate Studies and Research
In Partial Fulfillment of the Requirements for the Degree of
Doctor of Philosophy

Ottawa-Carleton Chemistry Institute
Department of Chemistry
University of Ottawa
Ottawa, Ontario
Canada

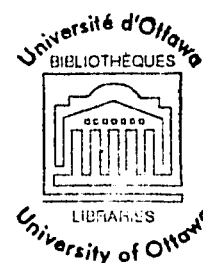

Candidate

Cathleen M. Crudden

Supervisor

Professor H. Alper

THE UNIVERSITY OF OTTAWA

November 1994

© Cathleen M. Crudden

UMI Number: DC52425

INFORMATION TO USERS

The quality of this reproduction is dependent upon the quality of the copy submitted. Broken or indistinct print, colored or poor quality illustrations and photographs, print bleed-through, substandard margins, and improper alignment can adversely affect reproduction.

In the unlikely event that the author did not send a complete manuscript and there are missing pages, these will be noted. Also, if unauthorized copyright material had to be removed, a note will indicate the deletion.

UMI[®]

UMI Microform DC52425
Copyright 2007 by ProQuest LLC
All rights reserved. This microform edition is protected against
unauthorized copying under Title 17, United States Code.

ProQuest LLC
789 East Eisenhower Parkway
P.O. Box 1346
Ann Arbor, MI 48106-1346

Table of Contents

Acknowledgments	vi
Abstract	viii
List of Schemes	xii
List of Tables	xiii
List of Figures	xiv
List of Abbreviations	xv
Chapter One: General Introduction	1
1.1 Introduction and Organization	1
1.2 Carbonylation Reactions	2
1.2.1 Hydroformylation	2
1.2.1.1 Catalysts, Additives and Selectivities	3
1.2.1.2 Mechanistic Considerations	7
1.2.2 Hydrocarboxylation and Hydroesterification Reactions	12
1.2.2.1 Catalysts, Additives and Selectivities	12
1.2.2.2 Mechanistic Considerations	16
1.2.3 Insertion / Substitution Reactions of Carbon Monoxide	19
1.2.3.1 The Insertion of Carbon Monoxide into Carbon Halogen Bonds	20
1.2.3.2 The Direct Insertion of Carbon Monoxide into Carbon Heteroatom Bonds in Heterocyclic Systems	26
1.2.3.3 The Insertion of Carbon Monoxide into Carbon Heteroatom Bonds in π -Allyl Systems	30

Chapter Two: The Hydroformylation of Vinylsilanes	33
2.1 Introduction	33
2.2 Results and Discussion	39
2.2.1 Rhodium Catalyzed Hydroformylation Reactions	39
2.2.2 Iridium Catalyzed Hydroformylation Reactions	51
2.2.3 Cobalt Catalyzed Hydroformylation Reactions	64
2.3 Conclusions	65
Chapter Three: Attempts to Prepare a New Catalyst for Asymmetric Hydroformylation	67
3.1 Introduction	67
3.1.1 Asymmetric Catalysis	67
3.1.2 Asymmetric Hydroformylation	70
3.2 Results and Discussion	75
3.2.1 Stability of Rh ^{ZW} Under the Reaction Conditions	75
3.2.2 Preparation and Testing of a Chiral Non-Racemic Arene as a Ligand for the Rhodium Catalyzed Hydroformylation of Alkenes	80
3.3 Conclusions	91
Chapter Four: Carbonylation of Carbon-Nitrogen and Carbon-Sulfur Bonds in Cyclic and Acyclic Systems	93
4.1 Introduction: Carbonylative Ring Expansion Reactions	93
4.2 Results and Discussion	96
4.2.1 Carbonylation of 1-Alkyl 1,2,3,4-Tetrahydroquinolines	96

4.2.2	Synthesis and Carbonylation of Compound 55	101
4.2.3	The Synthesis and Attempted Carbonylation of 1-Alkyl Tetrahydroquinoline Derivatives (60, 61 and 63)	103
4.2.4	Synthesis and Attempted Carbonylation of 1,3-Thiazane Derivatives (67, 68 and 70)	105
4.2.5	The Synthesis and Attempted Carbonylation of 2 <i>H</i> -3,6- Dihydro-1,3-thiazine Derivatives (75-78)	109
4.3	Conclusions	115
 Chapter Five: Carbonylation of Allyl Aryl and Allyl Alkyl Sulfides with Palladium and Ruthenium Catalysts		117
5.1	Introduction	117
5.1.1	Carbonylation of π -Allylic Substrates	117
5.2	Results and Discussion	126
5.3	Conclusions	136
 Chapter 6: Experimental		138
6.1	General Experimental	138
6.2	Experimental for Chapter 2	141
6.2.1	General Procedure for the Hydroformylation Reactions	141
6.2.2	Hydroformylation of Vinyltrimethylsilane	142
6.2.3	Hydroformylation of Vinyltriethylsilane in Benzene	144

6.2.4	Rh ^{zw} Catalyzed Hydroformylation of Vinyltriethylsilane in Various Solvents	145
6.2.5	Rh ⁺ Catalyzed Hydroformylation of Vinyltriethylsilane in Various Solvents	146
6.2.6	Additives in the Rh ^{zw} and Rh ⁺ Catalyzed Hydroformylations	147
6.2.7	Ir ⁺ Catalyzed Hydroformylation of Vinyltriethylsilane	148
6.2.8	IrCl ₃ Catalyzed Hydroformylation of Vinyltriethylsilane	150
6.2.9	Ir ^{zw} Catalyzed Hydroformylation of Vinyltriethylsilane	152
6.2.10	Miscellaneous Hydroformylations of Vinyltriethylsilane	154
6.3	Experimental for Chapter 3	156
6.3.1	General Details	156
6.3.2	High Pressure NMR Experiments	157
6.3.3	Treatment of Rh ^{zw} with CO and H ₂ in an Autoclave	158
6.3.4	Hydroformylation with Cationic Arene–Rhodium Complexes	159
6.3.5	Preparation of Chiral Cationic Arene–Rhodium Complexes	160
6.3.6	Catalytic Activity of Chiral Cationic Arene–Rhodium Complexes	162
6.4	Experimental for Chapter 4	163
6.4.1	Preparation of Starting Materials	163
6.4.1	Preparation of the Starting Material for Section 4.2.1	163
6.4.2	Preparation of the Starting Material for Section 4.2.2	164
6.4.3	Preparation of the Starting Materials for Section 4.2.3	167
6.4.4	Preparation of the Starting Materials for Section 4.2.4	170
6.4.5	Preparation of the Starting Materials for Section 4.2.5	175
6.4.2	Attempted Carbonylation Reactions	181
6.4.2.1	Carbonylation Reactions Attempted in Section 4.2.1	182
6.4.2.2	Carbonylation Reactions Attempted in Section 4.2.2	184

6.4.2.3	Carbonylation Reactions Attempted in Section 4.2.3	184
6.4.2.4	Carbonylation Reactions Attempted in Section 4.2.4	187
6.4.2.5	Carbonylation Reactions Attempted in Section 4.2.5	188
6.5	Experimental for Chapter 5	191
6.5.1	Preparation of Starting Materials	191
6.5.2	General Procedure for the Carbonylation Reactions	193
6.5.2.1	Carbonylation of Allyl 4-Methylphenyl Sulfide with [Pd(PPh ₃) ₄]	194
6.5.2.2	Carbonylation of Allyl 4-Methylphenyl Sulfide with Pd(OAc) ₂	195
6.5.2.3	Attempted Carbonylation of Allyl 4-Methylphenyl Sulfide with Miscellaneous Catalysts	196
6.5.2.4	Carbonylation Reactions of Allyl 4-Methylphenyl Sulfide with Ruthenium and Iridium Catalysts	197
6.5.2.5	Carbonylation Reactions with Pd(OAc) ₂ /DPPP and Ru ₃ (CO) ₁₂	200
	References	218
	Claims to Original Research	231
	Appendix: Selected Spectra	232

Acknowledgments

I would like to express my gratitude to Professor Alper for teaching me a great deal of new and exciting chemistry and encouraging me to try my own ideas even if they did not always work. I am also grateful to Dr. Alper for giving me the opportunity to spend 3 months in Japan, an experience which I will remember fondly. Without him it would never have been possible.

Next I would like to thank Alphonse for his help in the preparation of this thesis and for his patience and understanding during my life as a graduate student. Mostly I want to thank him for his love and support, which was steadfast and unwavering. His quiet strength meant more to me than he could know.

My family have also been a great support for me, and I would like to thank my mother and father and also my grandmother for their love and for always encouraging me to study and do my best. I also would like to thank Sarah, Mary and Patrick for their continued love and friendship.

I would like to thank the friends and colleagues that I have met here in Ottawa. Special thanks go to Dr. Vladimir Grushin for reading this thesis and giving extremely helpful suggestions and also for the many enjoyable conversations on chemistry and life and everything in between. I also want to thank Dr. Yuri Goldberg and Diana Zanini for their help with the experimental section of this thesis and also for their friendship.

My sincere thanks go to Dr. Kanjai Khumtaveeporn (a.k.a. Dang) for being a special friend to me from the first day I arrived. She is one of the kindest and sincerest people I have ever met and I hope that our friendship will span the oceans.

Finally, last but by no means least I would like to extend my deepest thanks to Dr. Claudio Sturino, my friend and confidant. As always, words are too pale to express my gratitude to him. His encouragement, advice and friendship were ever present. Without

his support much of the work presented in this thesis would not have been possible. I will cherish forever the good times we had in Toronto and in Ottawa.

I consider myself extremely lucky to have spent four years in the company of Alphonse, Claudio and Dang. I was always told that a person is lucky to have one true friend in their life, and I have had three.

Abstract

It has been demonstrated that the zwitterionic rhodium complex (Rh^{zw}), $[\text{Rh}(\text{COD})^+]\text{BPh}_4^-$, is an effective catalyst for the hydroformylation of vinylsilanes. With vinyltrimethylsilane, the branched aldehyde could be obtained as the major aldehyde isomer if the $\text{CO} : \text{H}_2$ ratio was 1 : 2 (total pressure = 200 psi). Under these conditions, 20–40% isolated yield was obtained and the low yield of these reactions was confirmed by experiments performed in deuterated solvents. The hydroformylation of vinyltriethylsilane, on the other hand, gave 66% of the desired aldehydes after 4h. The branched isomer was, however, the minor isomer with B : L selectivities of ca. 35 : 65. A cationic rhodium complex $[\text{Rh}(\text{COD})_2^+]\text{BF}_4^-$, abbreviated as (Rh^+), was also found to catalyze the hydroformylation of vinylsilanes, but only in aromatic solvents. With the addition of 1 equivalent of triphenylphosphine, the reaction did proceed in non-aromatic solvents. The addition of PPh_3 to the Rh^{zw} catalyzed reactions dramatically improved the yield and selectivity for the *linear* isomer such that after the addition of only 2 equivalents, the products were formed in 97% yield with a B : L ratio of 7 : 93. This system is therefore much more sensitive to the effect of phosphines than the neutral complexes reported previously by Takeuchi et al.⁶⁶ where the addition of 50–100 equivalents of phosphine was required in order to obtain >90% selectivity for the linear isomer.

The addition of PPh_3 to the reaction catalyzed by Ir^{zw} had an entirely different effect. If only 1 equivalent was added, the hydroformylation reaction was completely inhibited. In the absence of phosphine, however, all of the iridium systems examined were highly selective for the linear isomer (>90%). In some cases, the iridium complex needed to be preactivated at 160 °C for 1h under CO and H_2 in order for it to be an active hydroformylation catalyst. All of the Ir(I) complexes were active without this preactivation, but for Ir^{zw} , the approximately 3h inhibition period is not observed if the

complex is pretreated in the absence of substrate as previously described. Iridium trichloride was not active at all unless the preactivation protocol was employed or if silver tetrafluoroborate was added. In this last instance, reaction was only observed if the hydroformylation was carried out for 16h.

Iridium trichloride and iridium(carbonyl)chloride gave low to moderate yields of the silyl aldehydes, but the selectivity was excellent (only the linear isomer was detected in all runs but one where 98% linear was observed). The cationic iridium complex, $[\text{Ir}(\text{COD})_2^+]\text{BF}_4^-$, was the best overall iridium catalyst giving good yields (up to 80% by GC and 65% isolated) of the predominantly linear aldehyde (97–100%).

The unique solvent effects observed in the reactions of $[\text{Rh}(\text{COD})_2^+]\text{BF}_4^-$ were explained by postulating that the aromatic solvent was acting as a ligand for the low-ligated rhodium complex. Furthermore, the activity of the zwitterionic complex in non-aromatic solvents was explained by co-ordination of one of the phenyl rings of the counterion. To gain support for this proposal, the stability of Rh^{ZW} under the reaction conditions was examined using high pressure and simple NMR techniques. These experiments led us to conclude that under severe conditions (140 °C, 16h), 40% of the counterion is decomposed to benzaldehyde, benzyl alcohol and benzene. The mixture that resulted from this exhaustive treatment was shown to catalyze the hydroformylation of vinyltriethylsilane. However, when the rhodium complex was exposed to the conditions normally employed for carbonylation reactions, (namely 75 °C, 3h, 200 psi), less than 15% decomposition to benzaldehyde was observed, and no benzene or benzyl alcohol could be detected.

Finally, we prepared a number of arene-rhodium complexes and showed that they catalyzed the hydroformylation of vinyltriethylsilane in non-aromatic solvents. Chiral arene complexes were also prepared in order to test the enantioselectivity of the hydroformylation, but in these reactions, the branched isomer was completely isomerized to the enol silyl ether which did not permit assessment of the enantioselectivity. Other

olefins were poor substrates. Styrene and vinyl naphthalene were polymerized under the reaction conditions, and olefin isomerization was problematic in the attempted hydroformylation of aliphatic substrates.

The insertion of carbon monoxide into 6-membered ring heterocycles was examined using a variety of 1-alkyl-1,2,3,4-tetrahydroquinoline derivatives. It was found that under forcing conditions using Pd/Cu or Ru/Co complexes, up to 15% of products resulting from insertion of carbon monoxide could be observed. The isolation of these compounds and the determination of their structure was complicated due to the large amounts of metal salts employed, the decomposition of the remaining starting material and the low yields. MS data, however, confirmed that insertion of carbon monoxide had occurred.

When the alkyl substituent was a methylene ketone, enolization and dehydration was observed giving an *N*-acetylenic product in low yields (16–21%). A substrate containing a sulfur atom in a 1,3-relationship with the nitrogen was prepared in several steps and examined under the previously described conditions. The substrates, however, gave no reaction using Ru and Co, and only deketalization was observed under the Pd/Cu conditions.

A modified *N,S*-6-membered ring substrate was prepared which contained an endocyclic olefin. It was hoped that the introduction of this unsaturation would facilitate the carbonylation by the formation of a π -allyl metal intermediate. Several different compounds with this general structure were prepared, and in one case a small amount (5–7%) of carbonylated product was observed, but the yield of this compound could not be increased even by the use of stoichiometric amounts of palladium or ruthenium complexes.

Finally, we examined the carbonylation of allyl aryl and allyl alkyl sulfides and found that the combination of Pd(OAc)₂ and DPPP was effective only if a 1 : 1 ratio of metal : ligand was employed. Under these conditions, the α,β -unsaturated thioester

resulting from carbonylation and isomerization was formed in fair to good yields. Analysis of this compound by ^1H NMR indicated that it was 100% *trans*. When $\text{Ru}_3(\text{CO})_{12}$ was employed, the carbonylation could also be effected in lower yields after longer reaction times, and no isomerization of the product was observed. Thus the β , γ -unsaturated thioester was obtained from this reaction. The palladium catalyzed carbonylation was shown to proceed through a π -allyl intermediate since 2-butenyl and 1-(3-butenyl) phenyl sulfide gave the same product. Furthermore, this experiment suggests that the rate determining step was carbonylation and not oxidative addition.

List of Schemes

Scheme 1:	Industrial Uses of Butanal	3
Scheme 2:	Hydroformylation of Aliphatic Olefins With Phosphine Containing Cobalt Complexes	5
Scheme 3:	General Mechanism for the Hydroformylation Reaction	7
Scheme 4:	Metal Hydride Mechanism for the Hydrocarboxylation Reaction	17
Scheme 5:	Metal Carboxylate Mechanism for the Hydrocarboxylation Reaction	17
Scheme 6:	Cobalt Methoxylate Catalyzed Hydroesterification of Butadiene	19
Scheme 7:	The Monsanto Acetic Acid Process	21
Scheme 8:	Milstein's Studies on the Carbonylation of Benzyl Chloride	22
Scheme 9:	The Biphasic Palladium Catalyzed Carbonylation of Iodobenzene	23
Scheme 10:	The Hydroxide-Promoted Reduction of Pd(II) Phosphine Complexes	24
Scheme 11:	β -Lactams From Aziridines: Carbonylative Ring Expansion	26
Scheme 12:	Hydroformylation in the Preparation of Guaiazulene	33
Scheme 13:	Hydroformylation of Fluorinated Alkenes	34
Scheme 14:	The Utility of α - and β -Silylaldehydes	36
Scheme 15:	Asymmetric Hydroformylation of 2-Butene	71
Scheme 16:	Preparation of Quinazolinone (56)	100
Scheme 17:	Regioselectivity of Carbonylation of Acyclic <i>N,S</i> -Acetals	105
Scheme 18:	Preparation of 5, 6-Dihydro-1, 3-thiazine-4 <i>H</i> (66)	106
Scheme 19:	Nickel Catalyzed Carbonylation of Allylbromide	118
Scheme 20:	Palladium Catalyzed Carbonylation of Allylacetates	119
Scheme 21:	Palladium Catalyzed Carbonylation of Allylamines	121
Scheme 22:	Palladium Catalyzed Carbonylation of 3-(1-Butenyl) Phenyl Sulfide	140

List of Tables

Table 1:	Effects of Temperature and Ligands on the Cobalt Catalyzed Hydroformylation of Pentene	4
Table 2:	A Comparison of Rhodium and Cobalt Complexes in the Hydroformylation of Terminal Olefins	6
Table 3:	Hydroesterification of Straight Chain Terminal Alkenes	13
Table 4:	Effect of Pressure on the Branched to Linear Ratio in the Hydroformylation of Vinyltrimethylsilane	40
Table 5:	The Rh^{zw} Catalyzed Hydroformylation of Vinyltrimethylsilane	42
Table 6:	Rh^{zw} Catalyzed Hydroformylation of Vinyltriethylsilane in Various Solvents	45
Table 7:	Rh^+ Catalyzed Hydroformylation of Vinyltriethylsilane in Various Solvents	46
Table 8:	The Effect of Phosphine Ligands on the Rh^{zw} and Rh^+ Catalyzed Hydroformylation of Vinyltriethylsilane	48
Table 9:	The Effect of Excess Phosphine Ligands on the Rh^{zw} Catalyzed Hydroformylation of Vinyltriethylsilane	50
Table 10:	$[Ir(COD)_2]^+BF_4^-$ Catalyzed Hydroformylation of Vinyltriethylsilane	53
Table 11:	Iridium Trichloride Catalyzed Hydroformylation of Vinyltriethylsilane	55
Table 12:	Catalytic Activity of Ir^{zw} in the Hydroformylation of Vinyltriethylsilane After Preactivation at 160 °C	57
Table 13:	Catalytic Activity of Ir^{zw} in the Hydroformylation of Vinyltriethylsilane Without Preactivation	59
Table 14:	Hydroformylation of Vinyltriethylsilane with Various Rhodium Catalysts	82

Table 15:	Carbonylation of Allyl 4-Methylphenyl Sulfide with [Pd(PPh ₃) ₄]	124
Table 16:	Carbonylation of Allyl 4-Methylphenyl Sulfide with Palladium Acetate	126
Table 17:	Carbonylation with Ruthenium and Iridium Complexes	128
Table 18:	Palladium and Ruthenium Catalyzed Carbonylation of Substituted Allyl Aryl Sulfides Yielding α , β - or β , γ -Unsaturated Thioesters	131
Table 19:	Palladium and Ruthenium Catalyzed Carbonylation of Allyl Alkyl Sulfides Yielding α , β - or β , γ -Unsaturated Thioesters	132

List of Figures

Figure 1:	Structure of the Zwitterionic Complex Rh ^{zw}	10
Figure 2:	Rh ^{zw} Catalyzed Hydroformylation of Vinyltriethylsilane in Benzene	44
Figure 3:	The Ir ^{zw} Catalyzed Hydroformylation of Vinyltriethylsilane Without Preactivation	60
Figure 4:	Iridium (III), (I) and (0) Complexes as Catalysts for the Hydroformylation of Vinyltriethylsilane After Preactivation	62
Figure 5:	[Co ₃ (η^6 -C ₆ H ₆) ₃ (μ_3 -CO) ₂]BPh ₄ , (34)	64
Figure 6:	Binap and MOP: Effective Axially Dissymmetric Ligands	68
Figure 7:	Decomposition of Rh ^{zw} Under CO and H ₂ at 75° C	78
Figure 8:	Decomposition of Rh ^{zw} Under 500 psi of CO and H ₂ at 140° C	79
Figure 9:	Ethyl Ester of (S)-(-)-1-Phenethyl Alcohol (42)	89
Figure 10:	Preparation of Chiral-Non Racemic Rhodium-Arene Ester Complex (43)	89
Figure 11:	¹ H NMR of (E)-2-Butenoic acid S-(4-methylphenyl) ester (85)	123

List of Abbreviations

Ac	acetyl
B : L	Branched : Linear
Binap	2,2'-bis (diphenylphosphino)-1,1'-binaphthyl
Bn	benzyl
BPPM	<i>N</i> -butoxycarbonyl-4-diphenylphosphino-2-diphenylphosphino- methylpyrrolidine
Bu	butyl
COD	1,5-cyclooctadiene
Cp	cyclopentadienyl
Cy	cyclohexyl
DABCO	diazobicyclooctane
DMAP	<i>N,N</i> -dimethylaminopyridine
DMF	<i>N,N</i> -dimethylformamide
DMSO	dimethylsulfoxide
DPPB	1,4-bis(diphenylphosphino)butane
DPPE	1,4-bis(diphenylphosphino)ethane
DPPP	1,4-bis(diphenylphosphino)propane
ee	enantiomeric excess
equiv	equivalent
Et	ethyl
GC	gas chromatography
GPC	gel permeation chromatography
HMPA	hexamethylphosphorictriamide
HPLC	high performance liquid chromatography

HRMS	high resolution mass spectrometry
Hz	hertz
IR	infra red
Ir ⁺	[Ir(COD) ₂] ⁺ BF ₄ ⁻
Ir ^{zw}	[Ir(COD)] ⁺ BPh ₄ ⁻
LDA	lithium diisopropyl amide
LG	leaving group
MVK	methyl vinyl ketone
Me	methyl
MS	mass spectrometry
NBD	norbornadiene, bicyclo[2.2.1]hepta-2, 5-diene
NCS	<i>N</i> -chlorosuccinimide
NMR	nuclear magnetic resonance
NR	no reaction
NuH	nucleophile
PTC	phase transfer catalysis or phase transfer catalyst
Ph	phenyl
Pr	propyl
ppm	parts per million (δ scale)
PPTS	pyridinium <i>p</i> -toluene sulfonate
psi	pounds per square inch
py	pyridine
Rh ⁺	[Rh(COD) ₂] ⁺ BF ₄ ⁻
Rh ^{zw}	[Rh(COD)] ⁺ BPh ₄ ⁻
RT	room temperature
TBDMS	<i>t</i> -butyldimethylsilyl
THF	tetrahydrofuran

TLC	thin layer chromatography
TMEDA	tetramethylene(ethylene)diamine
TMS	trimethylsilyl

Chapter One: General Introduction

1.1 Introduction and Organization

This thesis will describe our research into transition metal catalyzed carbonylation reactions. Carbonylation reactions can be divided into two general classes, addition reactions and insertion/substitution reactions. In the general introduction to follow, I will describe the major categories within these two types of carbonylation reactions. One of the three kinds of addition reactions and two of the three types of CO insertion/substitution reactions discussed in the introduction are the subject of this thesis. Hydroformylation will be described in Chapters 2 and 3. Specifically, we have studied the hydroformylation of vinylsilanes catalyzed by rhodium and iridium complexes. Chapter 3 provides an account of our attempts to prepare a new chiral ligand for asymmetric hydroformylation. In Chapters 4 and 5 our efforts in the insertion/substitution area are described, specifically, the attempted carbonylative ring expansion of six membered rings is presented in Chapter 4. The palladium and ruthenium catalyzed carbonylations of allyl sulfides are described in Chapter 5.

1.2 Carbonylation Reactions

Transition metal complexes offer unique avenues for the creation of carbon-carbon bonds and for achieving asymmetric induction. Carbon monoxide is one of the most significant building blocks used with transition metal complexes for the formation of carbon carbon bonds. Carbon monoxide is incorporated into organic molecules either via an insertion/substitution reaction (for example into the carbon-iodine bond of iodomethane in the Monsanto process) or by an addition reaction where CO is added, along with hydride, hydroxide or alkoxide, across an unsaturated functional group. An important example of an addition reaction is the formal addition of the elements of "CHO" and "H" across the double bond of an olefin (hence the name *hydroformylation*). This reaction has immense industrial significance since propene and synthesis gas (CO/H₂) are readily available feedstocks and the butanal produced can be easily converted into valuable products (*vide infra*). Using this process, more than 800 million pounds of butanal are produced yearly.¹

1.2.1 Hydroformylation

The hydroformylation reaction is also known as the oxo process and was first discovered in 1938 by Otto Roelen during his research into the Fischer Tropsch process.² The reaction produces branched and linear aldehydes, the latter being more desirable in the commonest industrial processes (equation 1).

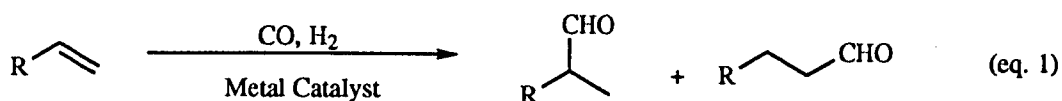

1.2.1.1 Catalysts, Additives and Selectivities

The linear product from the hydroformylation of propene, *n*-butanal, is useful since it can be hydrogenated to butanol, a chemical widely used as an industrial solvent, and it can also be converted to 2-ethylhexanol via sequential aldol and hydrogenation reactions (Scheme 1).³

Scheme 1: Industrial Uses of Butanal.

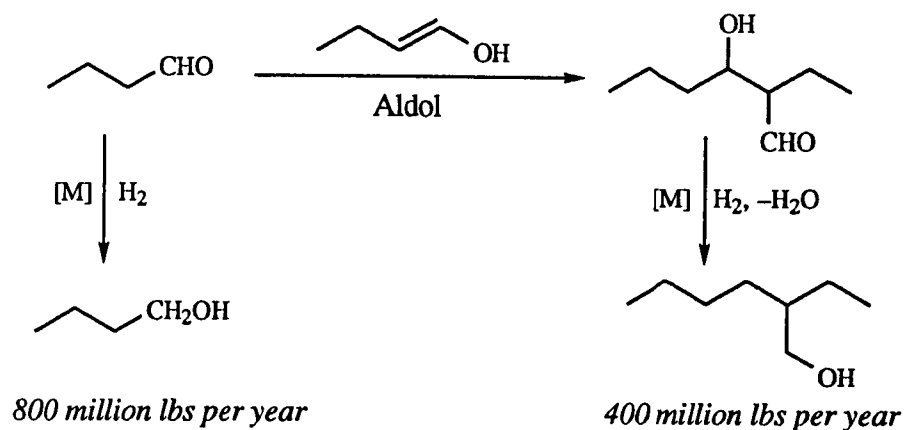

The early dicobalt octacarbonyl catalyzed process required elevated temperatures and pressures, and produced mixtures of the linear and branched aldehydes.⁴ The high temperatures and pressures resulted in significant energy consumption, and the separation of the two isomers represented an appreciable loss (20–25%) of propene and synthesis gas. The unwanted isobutyraldehyde can be either burned for fuel or cracked to regenerate propene and synthesis gas in an expensive catalytic process.⁵ Therefore it is not surprising that a considerable amount of research has been directed into finding milder catalysts that are more selective for the linear isomer.

Modification of the cobalt catalysts with phosphine ligands was unsuccessful since the resulting complexes are much less reactive than the original $\text{HCo}(\text{CO})_4$ systems.

Although a modest increase in the linear to branched (or *n* to iso) ratio was observed, the elevated temperatures required for the less active catalyst and the increased reducing power of the cobalt hydride made reduction of the aldehyde a serious problem. While this is not an issue for the synthesis of butanol since the hydrogenation is usually carried out as a second step, it means the process cannot be used for the preparation of 2-ethylhexanol.

In a comparative study, Slaugh and Mullineaux⁶ showed that under identical conditions, reduction of the aldehyde increased from 10% to 97% when tri *n*-butyl phosphine is added to the dicobalt octacarbonyl system. Furthermore, when the temperature is increased, which is necessary to obtain reasonable rates, 23% of the alkene is reduced to the corresponding alkane (equation 2, Table 1).

Table 1: Effects of Temperature and Ligands on the Cobalt Catalyzed Hydroformylation of Pentene.^a

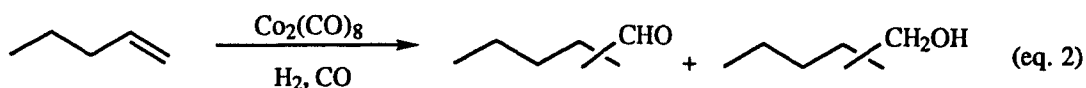

Temp. (°C)	Ligand	B : L	Aldehyde : Alcohol	Direct Reduction (pentane)
140 ^b	none	64 : 36	90 : 10	-
150 ^c	2 PBu ₃	16 : 84	3 : 97	-
195 ^c	2 PBu ₃	9 : 91	0 : 100	23 %

^a Taken from reference 6. ^b1700 psi CO ^c500 psi CO.

The greater activity of the non-phosphine system poses a more fundamental problem. Since HCo(CO)₄ is more reactive than HCo(CO)_nL_{n-4} (where L = a phosphine ligand), any dissociative equilibria under the reaction conditions will produce aldehydes with lower L : B ratios resulting from catalysis by HCo(CO)₄. The decreased activity of

those cobalt complexes containing phosphine ligands also explains the poor results obtained when researchers tried to effect asymmetric hydroformylation by modifying cobalt complexes with chiral non-racemic phosphine ligands. Since the phosphine containing complexes were less active than $\text{HCo}(\text{CO})_4$ and since the hydroformylation reaction was run under CO pressure, virtually no enantioselectivity was observed.⁷

Scheme 2: Hydroformylation of Aliphatic Olefins With Phosphine Containing Cobalt Complexes.

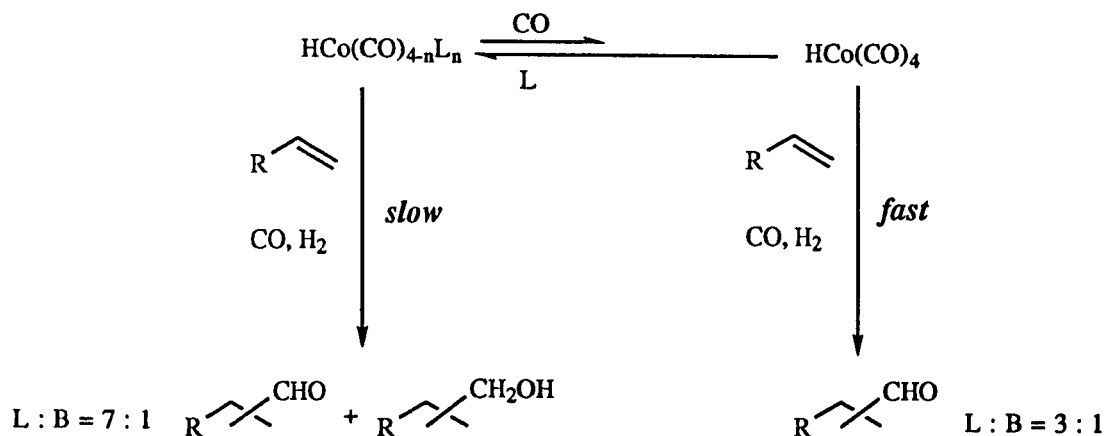

Rhodium complexes modified by phosphine ligands were considerably more active. Not only were the linear/branched ratios dramatically improved, but the competing hydrogenation observed in the cobalt catalyzed process was completely suppressed and the activity was 10^3 – 10^4 times greater than the conventional cobalt catalysts (Table 2).^{8, 1b}

Table 2: A Comparison of Rhodium and Cobalt Complexes in the Hydroformylation of Terminal Olefins.^a

Specifications	HCo(CO) ₄	Cobalt with Phosphine	Rhodium with Phosphine ^b
Pressure ^c	2800–4200	700–1400	140–280
Temperature	140–180	160–200	90–110
Linear : Branched	3–4 : 1	7 : 1	10–30 : 1
Major Product	RCHO	RCH ₂ OH	RCHO
Other By-Products	significant	moderate	minimal

^a Taken from references 3, 4, 8, 9 and 10. ^b It should be noted that certain rhodium–phosphine complexes catalyze the hydroformylation under considerably milder conditions. For example, HRh(CO)(PPh₃)₃ is active at room temperature and 1 atm of syn gas, reference 11. ^cIn psi.

Rhône–Poulenc has patented a method for the hydroformylation of propene using sulfonated phosphines and a biphasic system.¹² This method permitted the facile separation of the catalyst (which was water soluble) and the organic products. The phosphines are easily prepared by sulfonation of triphenylphosphine with 33% SO₃ in H₂SO₄ followed by careful hydrolysis.^{12d} Davis and Hanson have prepared similar systems in which the water soluble rhodium complex of a tri-sulfonated phosphine is impregnated, along with water, onto a hydrophilic porous support.^{12e} This system (also known as SAP for Supported Aqueous Phase) has been shown to be effective for the hydroformylation of terminal alkenes giving high selectivity for the linear isomer (L : B = 13 : 1) under appropriate conditions.^{12f,g}

1.2.1.2 Mechanistic Considerations

Much is known about the mechanism of the rhodium catalyzed hydroformylation reaction. The reaction is presumed to begin by complexation of the olefin to the metal. This step was shown to be the rate determining step for the hydroformylation of hindered olefins.¹³ The next step is the addition of the rhodium hydride across the olefin to produce a metal alkyl complex (1) or (1'), from delivery of the hydride to the internal or terminal positions. Insertion of carbon monoxide into the metal-carbon bond generates a metal acyl complex. Reductive elimination of the aldehyde regenerates the metal hydride catalyst. For unhindered olefins, the reductive elimination is presumed to be the rate determining step. The general reaction sequence is shown in Scheme 3.

Scheme 3: General Mechanism for the Hydroformylation Reaction.

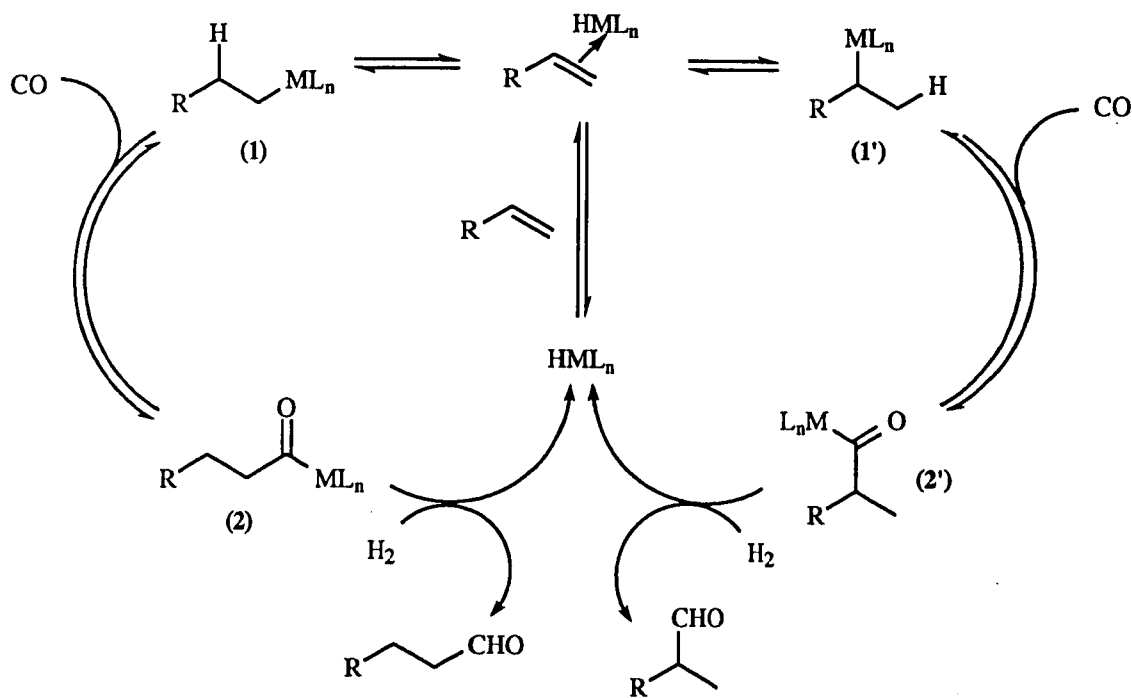

M = metal, L = any ligand, i.e. CO or PPh_3 , n = *any number* of ligands

The exact mechanism of the elimination of the aldehydes from acyl complexes (2) and (2') is unclear. One possibility is oxidative addition of hydrogen to the metal acyl complex followed by reductive elimination of the aldehyde (equation 3).

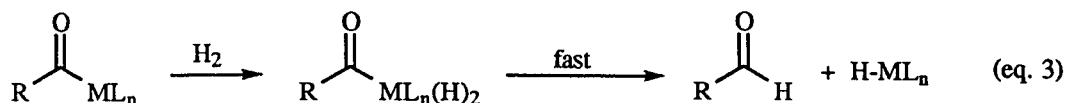

The reductive elimination could also proceed by a bi-molecular process in which the metal acyl reacts with a molecule of $\text{HM}(\text{CO})_{4-n}\text{L}_n$ eliminating the aldehyde and regenerating the metal hydride catalyst (equation 4). Elegant work by Collman et al.¹⁴ supports the bi-molecular reaction mechanism. They prepared phosphine substituted rhodium complexes bound to silica and showed that only those complexes close enough to undergo bi-molecular reductive elimination displayed catalytic activity. Extrapolation of this result to homogeneous systems, however, may not be straightforward.



Excellent selectivities for the linear aldehyde are obtained with rhodium-phosphine systems only under conditions of high phosphine concentration, low CO partial pressure and low total pressure. These results were explained by the series of equilibria which are shown in equation 5. High ligand concentrations (up to 100:1 $\text{PR}_3:\text{Rh}$)^{11c} and low CO pressures favour a species containing more than one phosphine (e.g. compound 4).¹⁵ This type of complex offers a more sterically demanding environment to the alkene and thus high linear to branched ratios are obtained.^{11a, c}

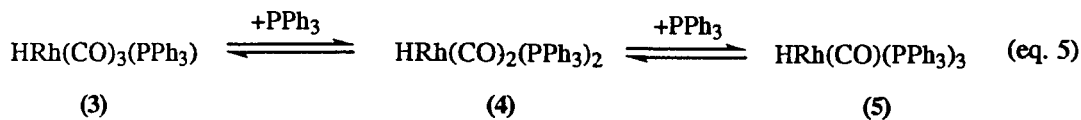

Since its inception, most of the research into the hydroformylation reaction has been directed towards determining the mechanism or improving the amount of the linear isomer. The recent discovery of the potent analgesic properties of 2-arylpropionic acids has promoted increased efforts into affecting the branched-selective hydroformylation of vinylarenes.¹⁶ The 2-aryl propanal products can be easily converted into the biologically active propionic acids by oxidation¹⁷ (Chart 1).

Chart 1: Aryl Propionic Acids with Analgesic Properties

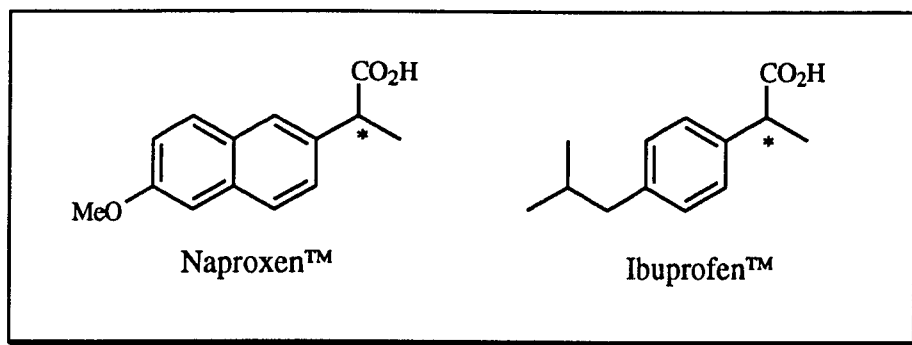

One of the most successful systems for the hydroformylation of styrene and its derivatives was recently described by Alper and Amer.^{18a} They reported that a zwitterionic rhodium complex described in 1970 by Schrock and Osborn^{18b} is a very mild and selective catalyst for the hydroformylation of a variety of compounds. This complex, $[\text{Rh}(\text{COD})^+]\text{BPh}_4^-$, contains a η^6 -coordinated arene in the solid state and in solution.^{19a, 18b}

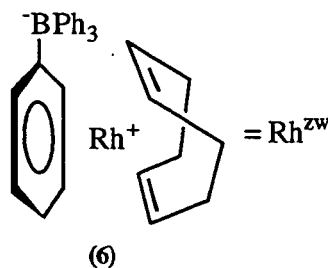
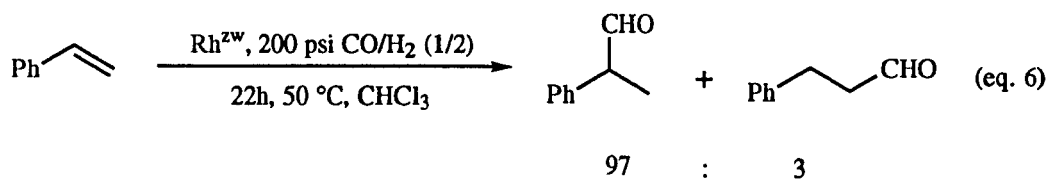

Figure 1: Structure of the Zwitterionic Complex Rh^{zw} .

Using complex (6), which will be denoted as Rh^{zw} , vinylaromatics, vinyl ethers and vinyl acetates were hydroformylated to yield the branched aldehydes as the predominant or only products. The conditions of the reaction are exceedingly mild, with temperatures as low as 50 °C required for reasonable to good conversions of starting material to product. The pressures employed (≤ 200 psi) are also moderate.



Rh^{zw} is also an effective catalyst for the hydroformylation of vinylidene olefins yielding the linear aldehydes specifically. Simple alkenes and α, β -unsaturated esters, however, are poor substrates for this reaction giving equal amounts of branched and linear aldehydes. It was reported by Alper and Zhou²⁰ that by simply adding 2 equivalents of DPPB per rhodium, the hydroformylation of α, β -unsaturated esters could be affected with excellent regioselectivity. The isomer obtained in all of the substrates examined is that which places the formyl unit α - to the carbonyl functionality.

1.2.2 Hydrocarboxylation and Hydroesterification Reactions

The addition of "H" and "COOR" across an olefin is called hydrocarboxylation for R=H and hydroesterification for R=alkyl or aryl. The reaction is effected by the addition of water or an alcohol to the catalytic system. The overall reaction is shown below.

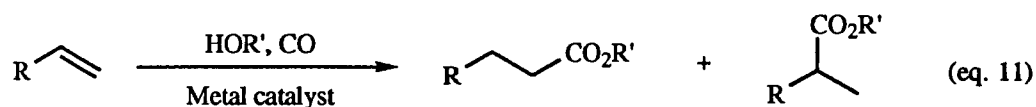
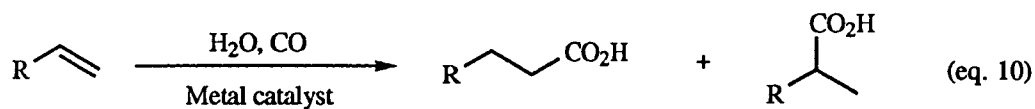

1.2.2.1 Catalysts, Additives and Selectivities

A variety of catalysts effect the hydrocarboxylation of alkenes, but palladium has been used most frequently. Palladium complexes such as $\text{Pd}(\text{PPh}_3)_2\text{Cl}_2$ catalyze the hydroesterification of alkenes under reasonably mild conditions, but the linear to branched ratio is poor compared to nickel or cobalt catalysts.²² The addition of tin (II) chloride to palladium mediated systems dramatically improves the regioselectivity²³ (see Table 3).

Table 3: Hydroesterification of Straight Chain Terminal Alkenes.^a

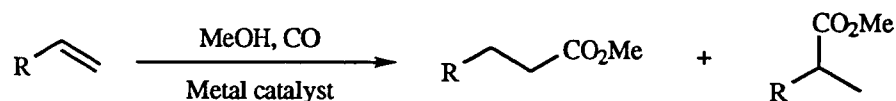

Catalyst System	Additive	R	Pressure (psi)	Temp (°C)	Yield (%)	L : B ^b
Co ₂ (CO) ₈	none	<i>n</i> -Pr	1400–2800	140–170	80–90	70 : 30
Pd(PPh ₃) ₂ Cl ₂	none	<i>n</i> -Hex	500	80–110	80 ^c	60 : 40
Pd(PPh ₃) ₂ Cl ₂	10 SnCl ₂	<i>n</i> -Pent	2000	80	96 ^c	87 : 13
Pt(AsPh ₃) ₂ Cl ₂	10 SnCl ₂	<i>n</i> -Pent	3400	80	95 ^c	98 : 2

^a Taken from references 22, 23 and 24 ^b L : B = Linear : Branched.

The most successful system for the hydrocarboxylation of simple aliphatic olefins is the platinum–tin system shown in the last entry of Table 3.²³ The dramatic improvement in the linear selectivity has been ascribed to the replacement of one of the chloride ligands by the sterically demanding SnCl₃⁻.²⁵ This effect is similar to that observed on increasing the amount of triphenylphosphine in the hydroformylation of propene with rhodium catalysts (*vide infra*). In fact the addition of excess triphenylphosphine also increases the amount of the linear isomer produced in the hydroesterification²⁶, but the addition of tin (II) chloride has a more pronounced effect.

The hydrocarboxylation of styrene (like the hydroformylation) is selective for the branched isomer. One peculiarity of this Pd/Sn system is that the addition of chelating phosphines such as DPPB completely destroys the selectivity giving a 1 : 1 mixture of branched and linear isomers.²⁷

Another additive which has found considerable use in palladium catalyzed hydrocarbonylation reactions is cupric chloride. Although it is thought that the copper chloride is needed to reoxidize the palladium (0) complex to the active Pd (II) species in analogy with the Wacker process²⁸, some evidence exists that this is not the case. It has been proposed that the copper is also involved in the main catalytic cycle, perhaps as a heterobimetallic species.²⁹ Regardless of the exact nature of the catalytic species, the Pd/Cu system has been shown to be a mild and regioselective method for the hydroesterification of a variety of alkenes.

Alper et al. showed that a combination of PdCl₂, CuCl₂, HCl, H₂O, O₂ and CO promoted the regioselective hydrocarboxylation of aliphatic olefins at room temperature under 1 atmosphere of CO (equation 12).³⁰ The branched isomer was obtained exclusively in all the terminal olefins studied. Even more remarkably, the hydrocarboxylation of *internal* olefins with the alkene at the 2-position was also regioselective giving only the 2-methylalkanoic acid (equation 13).

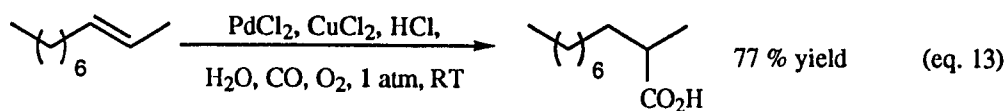
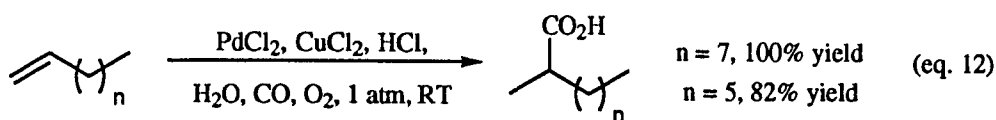

The application of this system to styrene and its derivatives was also highly successful. Using 10% PdCl₂ and 20% CuCl₂, under one atmosphere of CO as previously described, 4-isobutylstyrene was hydrocarboxylated in 89% yield. 6-Methoxy-2-vinylnaphthalene was also hydrocarboxylated with excellent selectivity. The addition of a chiral phosphate derived from BINAP (see Figure 6 in Chapter 3) to the

reaction mixture gave carboxylic acids with ee's of up to 89%.³¹ The acids produced in these two cases are potent analgesics known by the trade names of Ibuprofen™ and Naproxen™ (compare equations 14 and 15, and Chart 1).

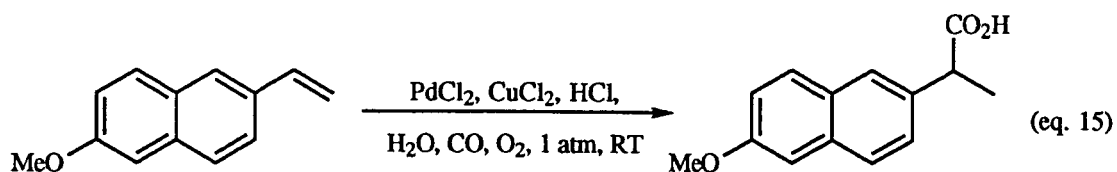
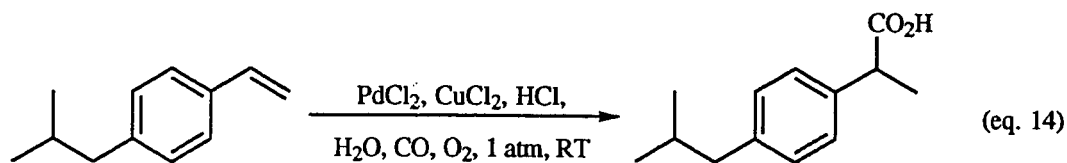

Another system that was shown to be effective in the hydrocarboxylation of olefins under mild conditions employs formate esters in combination with HCl and PdCl₂/CuCl₂ as previously described. While low yields of the desired carboxylic acids were obtained in the hydrocarboxylation of *p*-methylstyrene, moderate to good yields were obtained when terminal aliphatic olefins were used as substrates.³²

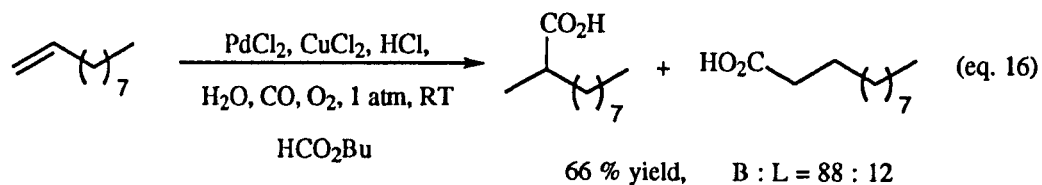

1.2.2.2 Mechanistic Considerations

There are two proposed mechanisms for the hydrocarbalkoxylation reaction. The first, commonly called the metal hydride mechanism, is quite similar to that suggested for the hydroformylation reaction. The first step is the *in situ* generation of a metal hydride which adds across the olefin producing an organometallic species. In the hydroformylation reaction, hydrogen gas is added to the reaction mixture, so the metal hydride is easily generated, while water or alcohol is present in hydrocarbalkoxylation. When water is added (or if the alcohol contains water), the water-gas-shift-reaction³³ can provide the necessary hydrogen (equation 17).

Water-gas-shift-reaction

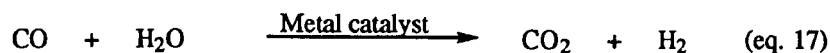

Alternatively, acid is sometimes added to the reaction mixture which can protonate the low oxidation state electron-rich metal producing a metal hydride. Hydrogen gas can even be added to the reaction mixture and has a beneficial effect on the hydrocarbalkoxylation with no competing hydroformylation observed.³⁴

After generation of the metal hydride and addition across the olefin, treatment of the resulting metal alkyl species, (7) and (7'), with carbon monoxide leads, via an alkyl migration, to the isomeric metal acyl complexes (8) and (8'). These complexes have been isolated when M is Pd and have been shown to catalyze the hydroesterification reaction.^{34a} Attack on the metal acyl by water leads to the carboxylic acid product or by alcohol produces the ester and in both cases the metal hydride catalyst is regenerated. Toniolo's and Knifton's elegant mechanistic studies of this reaction have virtually proved this mechanism in the palladium catalyzed systems they studied (Scheme 4).^{34a, 24}

Scheme 4: Metal Hydride Mechanism for the Hydrocarboxylation Reaction.

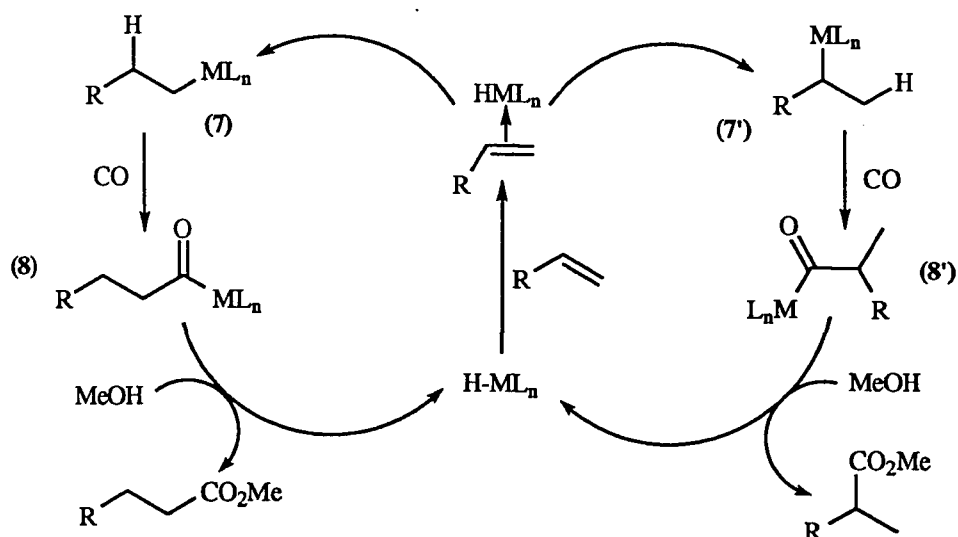

Alternatively, it has been proposed that metal bound carbon monoxide is attacked by the nucleophile (water or alcohol) and a metal carboxylate is formed (Scheme 5).³⁵ The metal carboxylate (9) then adds across the olefin producing isomeric metal alkyl complexes (10) and (10'). Reaction with another molecule of water or alcohol releases the product and regenerates the metal carboxylate catalyst.

Scheme 5: Metal Carboxylate Mechanism for the Hydrocarboxylation Reaction.

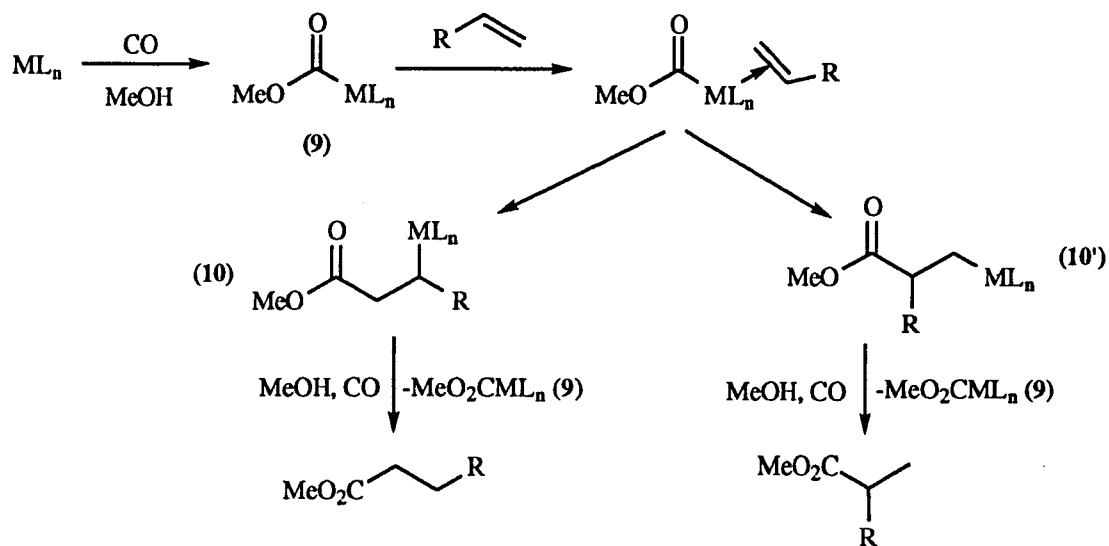

Norton studied the intramolecular hydroesterification of alkynols to methylene lactones. The palladium carboxylate species resulting from the attack of the alcohol on the palladium bound carbon monoxide was shown to be converted into the product lactone under the reaction conditions. Furthermore, no isomerization of the exocyclic olefin was observed which implies the absence of metal hydride species. Although these results provide evidence for the carbalkoxy mechanism, extrapolation to other systems must be done with care since subtle differences in the catalytic system can have a profound effect on the mechanism of the reaction.

As previously stated, Toniolo³⁴ showed definitively that the carbomethoxy complex, *trans*-MeCO₂Pd(Cl)(PPh₃)₂, did not catalyze the hydroesterification of simple alkenes. It is likely that both mechanisms are possible depending on the exact nature of the ancillary ligands. For example, it is known that coordinated carbon monoxide is much more susceptible to nucleophilic attack (for example by methanol) when the metal is substituted with electron withdrawing ligands such as carbonyls and it is much less susceptible to attack when the metal contains electron rich ligands like phosphines.³⁶

Milstein has proposed that carbalkoxy species are more important in substrates containing M-C bonds that are reluctant to undergo carbonylation, such as π -allyl systems.^{35a,b} Thus, an independently prepared cobalt carboxylate (11) was shown to add to butadiene producing the cobalt π -allyl complex (12). Reaction with another molecule of HCo(CO)₄ produces the ester and Co₂(CO)₇, which, on reaction with methanol and CO, regenerates the cobalt carboxylate (Scheme 6).

Scheme 6: Cobalt Methoxylate Catalyzed Hydroesterification of Butadiene.

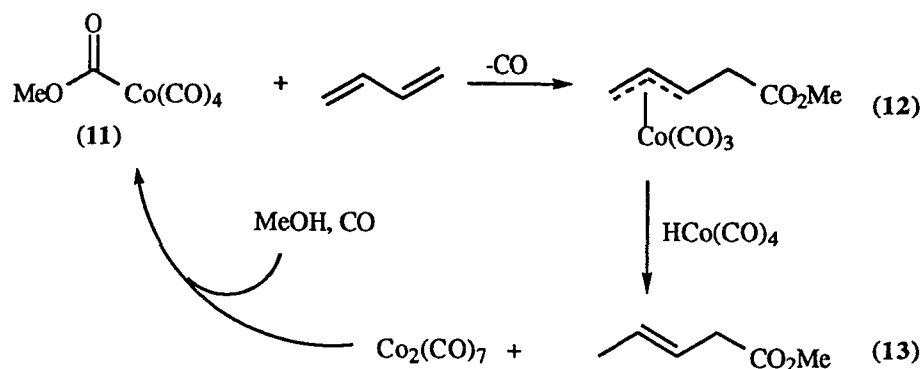

Regardless of the mechanism, the hydrocarbalkoxylation of alkenes is a useful method for the synthesis of esters and their derivatives from the corresponding alkenes.³⁷

1.2.3 Insertion/Substitution Reactions of Carbon Monoxide

There are three basic types of insertion/substitutions of carbon monoxide into organic molecules: insertion into activated acyclic carbon-X bonds such as the carbonylation of iodomethane or iodobenzene; insertion into cyclic carbon-heteroatom bonds such as the carbonylation of aziridines producing β -lactams; and the carbonylation of acyclic carbon-heteroatom bonds via π -allyl intermediates. These three types are illustrated below (equations 18, 19 and 20).

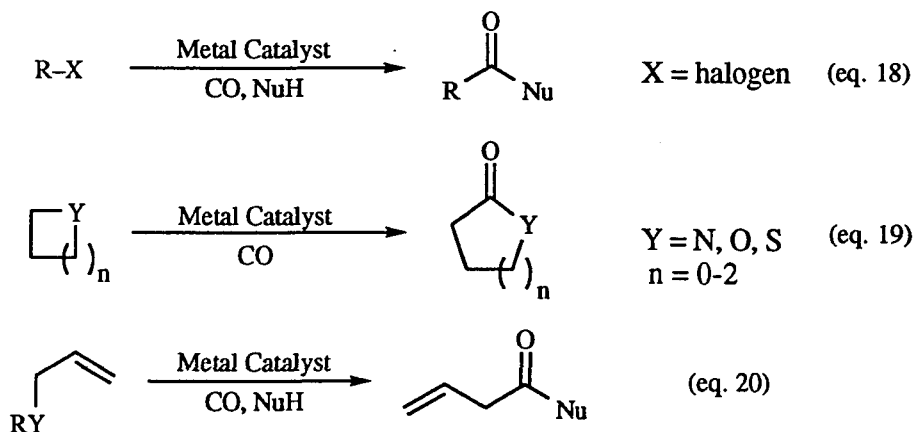

1.2.3.1 The Insertion of Carbon Monoxide into Carbon Halogen Bonds

The insertion of CO into carbon halogen bonds has been studied in detail because of its industrial significance. The Monsanto process for the rhodium complex catalyzed carbonylation of iodomethane (produced *in situ* from methanol) is used for the synthesis of 5 million tons of acetic acid annually.³⁹ Since its description in 1968, there has been a considerable amount of research into determining the mechanism of this carbonylation reaction.^{38, 39} The active catalyst for the Monsanto process is $[\text{Rh}(\text{CO})_2\text{I}_2]^-$, compound **14** in Scheme 7. The anionic nature of the catalyst is crucial to the success of the process since the catalytic cycle begins with a rate limiting oxidative addition into the carbon iodide bond of *in situ* generated iodomethane.³⁹ The reaction proceeds with alkyl migration producing a rhodium acyl species followed by reductive elimination of acetyl iodide which is converted *in situ* to acetic acid. The proposed mechanism is shown in Scheme 7.

Scheme 7: The Monsanto Acetic Acid Process

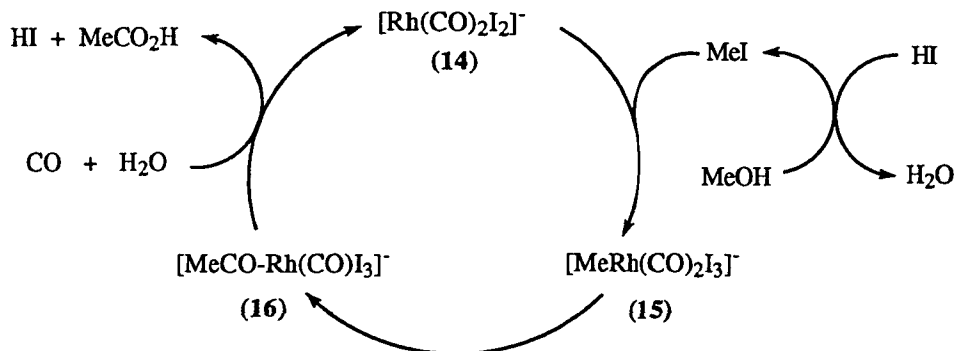

The rate limiting step is thought to be the oxidative addition of iodomethane since high pressure infrared studies showed that the carbonyl iodide complex **14** was the most prevalent species in solution.⁴⁰ Furthermore, reaction of this complex with iodomethane permitted the detection and isolation of a rhodium acyl complex shown as compound **16** in Scheme 7 and none of the methyl–rhodium complex (**15**) was detected. Thus it was proposed that the oxidative addition was the rate limiting step.^{41b}

Another possible explanation of the experimental results is that the reductive elimination of iodomethane from compound **15** is facile and that the alkyl migration step (i.e. **15** to **16**) is in fact rate determining. This possibility was discounted by the detailed mechanistic investigations of Maitlis et al., who showed that the original proposal was in fact correct.⁴² By performing the carbonylation in neat iodomethane, they were able to slow down the alkyl migration step and observe the methyl rhodium species (**15**) by NMR and IR spectroscopy.⁴³ Furthermore, they calculated the rate constants for each step in the conversion of **14** to **16**, confirming that the oxidative addition was rate limiting.

A related process is the carbonylation of iodobenzene which is usually catalyzed by palladium complexes. This reaction also begins with oxidative addition of the carbon iodide bond, and is followed by the insertion of CO into the palladium–carbon bond

(alkyl migration). Attack of the external nucleophile (H_2O , ROH or HO^-) gives the desired product and regenerates the active catalyst.⁴⁴ Alternatively, the oxidative addition could be followed by generation of a $\text{Pd-CO}_2\text{R}$ species by attack of the nucleophile on co-ordinated CO. Reductive elimination of the alkyl and carbalkoxyl ligands would then afford the product and regenerate the catalyst.

Milstein has shown that for phosphine containing palladium complexes, the reductive elimination of Pd-alkyl and $\text{Pd-CO}_2\text{Me}$ ligands is *not* the final step in the carbonylation reaction. They have prepared a palladium benzyl complex (17), Scheme 8, and converted it to the corresponding carbomethoxy (18) and acyl (19) species by treatment with ClHgCO_2Me or carbon monoxide respectively.^{35b} Heating the acyl complex in the presence of triethylamine produced the desired benzylester, but the carbomethoxy complex was unreactive under these conditions. From these studies Milstein concluded that "the rate-determining product-forming step involves methanolysis of (19) and not reductive elimination of a carbalkoxy complex." ^{35b}

Scheme 8: Milstein's Studies on the Carbonylation of Benzyl Chloride.

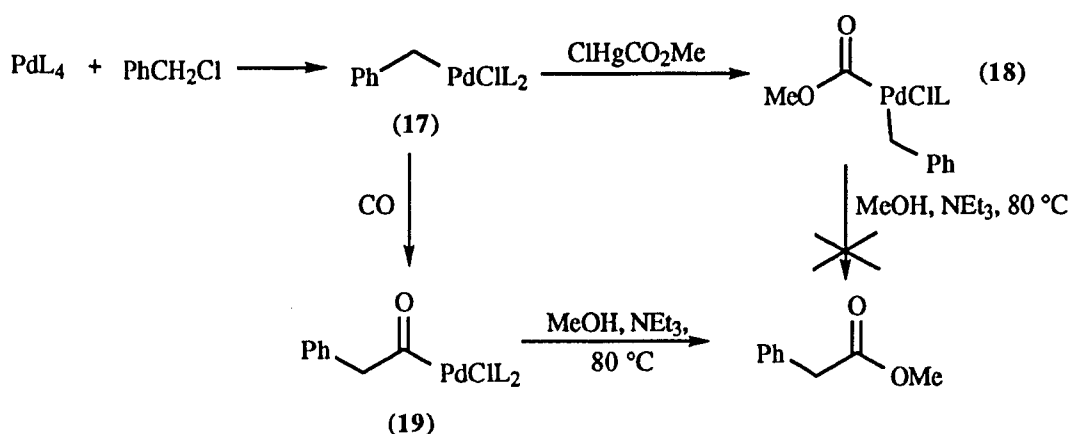

Since the first step of the reaction is the oxidative addition of the carbon iodine bond, the oxidation state of palladium must be zero. However, palladium (II) species

such as $\text{Pd}(\text{PPh}_3)_2\text{Cl}_2$ are often used in this reaction, and the mechanism of their reduction to $\text{Pd}(0)$ species was, until recently, unknown. Excess carbon monoxide or hydrogen (produced by the water-gas-shift-reaction) have been postulated to be responsible for the reduction, but no evidence for any of these suggestions has been advanced. Grushin and Alper have recently reported a thorough study of the reaction shown in equation 21 under biphasic conditions and have determined that hydroxide is in fact the species that affects the reduction of $\text{Pd}(\text{II})$ to $\text{Pd}(0)$ at the expense of the phosphine ligands.⁴⁵

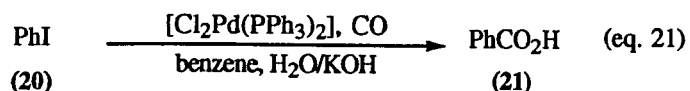

The reaction of bis(triphenylphosphine)palladium dichloride with potassium hydroxide in a benzene/water mixture produces $\text{Pd}(0)$ and OPPh_3 . If this reaction was run in the presence of iodobenzene, σ -phenyl complex (22) was isolated in high yield (75–86%) along with triphenylphosphine oxide. Treatment of this complex with carbon monoxide and iodobenzene yielded benzoic acid along with a palladium benzoyl species (23) shown in Scheme 9. The catalytic cycle is completed by treatment of the benzoyl complex with potassium hydroxide and iodobenzene which regenerates complex (22).

Scheme 9: The Biphasic Palladium Catalyzed Carbonylation of Iodobenzene

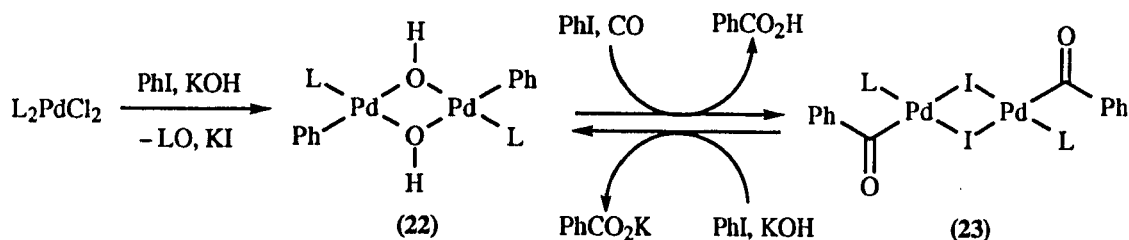

The exact mechanism of the reduction of $\text{Pd}(\text{II})$ to $\text{Pd}(0)$ was also elucidated by the use of chiral phosphine ligands. One possible mechanism is the direct attack of

hydroxide ion on the phosphine ligand followed by reductive elimination of phosphine oxide and an anionic palladium hydride (**24**). Further elimination of HCl and Cl⁻ generates the highly coordinatively unsaturated zero valent "Pd(PPh₃)" which undergoes oxidative addition of PhI and begins the catalytic cycle. Alternatively, ligand exchange of Cl⁻ for HO⁻ followed by reductive elimination of triphenylphosphine oxide generates a closely related palladium hydride (**25**). Loss of HCl then generates the catalyst, as shown in Scheme 10.

Scheme 10: The Hydroxide-Promoted Reduction of Pd(II) Phosphine Complexes

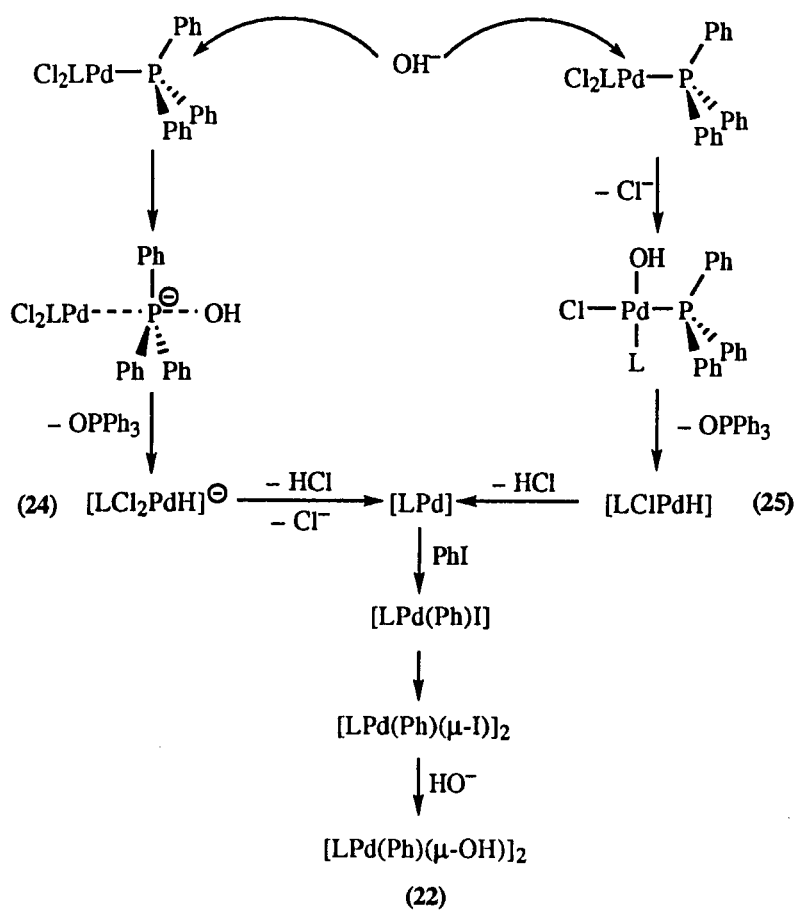

When the reaction was run using the enantiopure (*R*)-benzylmethylphenylphosphine palladium complex, the (*S*)-phosphine oxide was isolated in greater than 99%

optical purity. Therefore, the reaction proceeded with retention of configuration ruling out the mechanism which involves the direct attack of hydroxide on the phosphine.

Although the mechanism of the reduction of Pd(II) to Pd(0) was elucidated for the biphasic benzene/aqueous KOH system, the results are likely applicable to palladium catalyzed carbonylation reactions run under other conditions. Furthermore, they may be applicable to other types of palladium(0) catalyzed reactions. This is because many researchers use air stable Pd(II) complexes for other reactions which must be catalyzed by palladium(0) species. These reactions include the Heck reaction,⁴⁶ certain cross coupling reactions⁴⁷ and the Suzuki reaction.⁴⁸ Although hydroxide ion is usually not used in these reactions, other bases, especially triethylamine, are employed in order to mop up the acid that is produced. Considering that equimolar amounts of the base and catalytic quantities of the palladium catalyst are employed, only small amounts of adventitious moisture are needed to produce enough hydroxide via the reaction shown in equation 22, to reduce the Pd(II) to Pd(0).

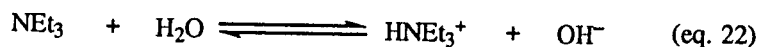

As well as discovering key mechanistic details in the carbonylation of aryl iodides, Grushin and Alper showed that the biphasic carbonylation could also be applied to arylchlorides by simply substituting $[\text{Pd}(\text{PCy}_3)_2\text{Cl}_2]$ for $[\text{Pd}(\text{PPh}_3)_2\text{Cl}_2]$ in the previously described biphasic reactions (equation 23). This is a significant advance in the carbonylation of aryl halides since iodo- and bromoarenes are much more expensive than the chloro analogs and until now there was no simple, effective method for the carbonylation of aryl chlorides.⁴⁹

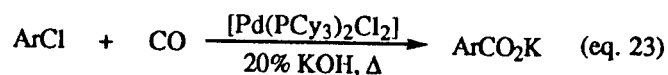

1.2.3.2 The Direct Insertion of Carbon Monoxide into Carbon-Heteroatom Bonds in Heterocyclic Systems

Direct insertion reactions of carbon monoxide are rather rare. Substitutive processes such as those described in the preceding section are much more common. The one case where direct insertion reactions are well studied is the insertion of carbon monoxide into cyclic carbon-heteroatom bonds. Until recently, this reaction had been confined to systems containing strain energy, particularly three and four membered rings. The aziridine to β -lactam transformation is a particularly important example, and the proposed mechanism is shown in Scheme 11.

Scheme 11: β -Lactams From Aziridines: Carbonylative Ring Expansion.

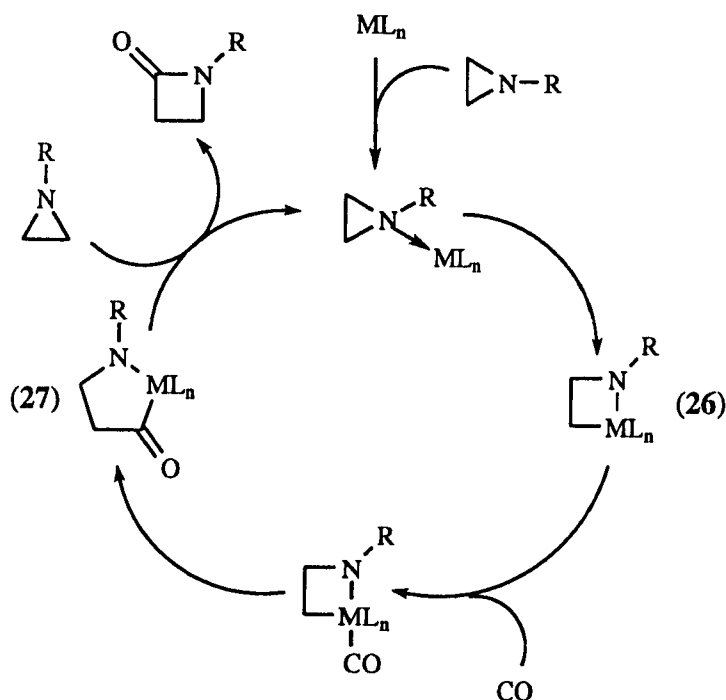

The reaction presumably begins with complexation of the aziridine to the metal complex. Oxidative addition of the C-N bond to the metal is the next step which relieves

the strain energy present in the three-membered ring producing the metallocycle **26**. Alkyl migration gives the metal acyl complex **27** which yields the product by reductive elimination.

The aziridine to β -lactam reaction was first carried out by Alper and Urso.⁵⁰ Rhodium carbonyl chloride modified by KI proved to be the most suitable system, and it was later found that modification of this system by *d*- or *l*-menthol allowed for a kinetic resolution of the racemic aziridine (see equation 58 on page 69).⁵¹ This system not only produced highly enantioenriched β -lactams, but also provided a convenient method for the resolution of aziridines.

It was subsequently demonstrated that the carbonylative ring expansion was quite general and applicable to other strained heterocycles. Thus, suitably functionalized azirines and azetidines were also carbonylated under reasonably mild conditions in high yields (equations 24 and 25).⁵² The regioselectivity of the carbonylation of the azetidines was found to be dependent on the nature of the substituent α to nitrogen (R' in equation 25). When R' was alkyl, insertion occurred regiospecifically into the less substituted cyclic C-N bond yielding compound (**29**), and when R' was Ph, compound (**28**) was obtained in 90% yield with only traces of (**29**) being detected.

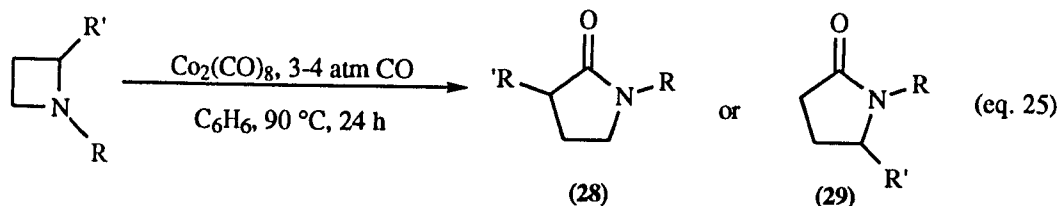
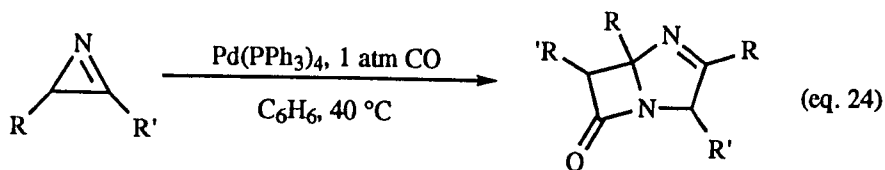

Other heterocycles including oxiranes, oxetanes and their thio analogs⁵³ are also carbonylated using related catalytic systems (see equation 11).

A considerable advance in this type of CO insertion chemistry was achieved when conditions were discovered which affected the carbonylation of *non-strained* five-membered ring heterocycles, specifically pyrrolidines (equation 26).⁵⁴ The position of the carbonylation was dependent on the ring substituent as in the azetidine series.

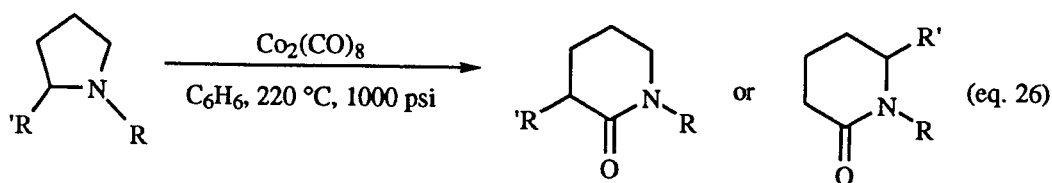

It was found that the addition of catalytic amounts of $\text{Ru}_3(\text{CO})_{12}$ to the cobalt system increased the yield of the pyrrolidine when R (in equation 26) was $\text{CH}_2\text{CO}_2\text{Et}$. When this Co/Ru system was applied to the carbonylative ring expansion of substrates with methylene *ketone* side chains, such as $-\text{CH}_2\text{COPh}$ or $-\text{CH}_2\text{COC}(\text{CH}_3)_3$, an unusual carbonyl transposition reaction was observed. Furthermore, it has been shown that this unprecedented carbonyl transfer reaction occurs for a variety of heterocycles (containing 5–8 membered rings, equation 27).⁵⁴ The reaction is also regioselective when there is a choice between two different α -methylene carbon atoms as shown in equation 28. The isomeric perhydroisoquinolin-1-one from “oxidation” of the more hindered ring methylene group was isolated in only 9% yield.⁵⁴

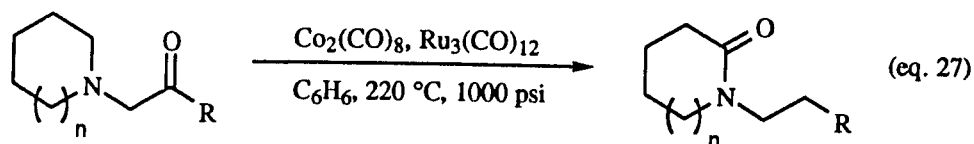

R = Ph, $\text{C}(\text{CH}_3)_3$, $n\text{-C}_6\text{H}_{13}$, $2\text{-C}_{10}\text{H}_{17}$
 $n = 0, 1, 2, 3$

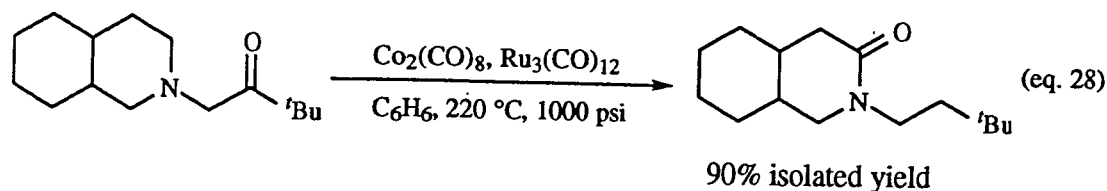

Recently, a study of the carbonylation of rings containing two different heteroatoms revealed that 1, 3-thiazines could also be carbonylated to yield, after a unique ketene elimination/carbonylation sequence, thiazolidinones (30).^{55a} When the substituent on nitrogen was a methylene ester (i.e. R = -CH₂CO₂Et), the carbonylated product (31) could be isolated before it underwent ketene elimination.

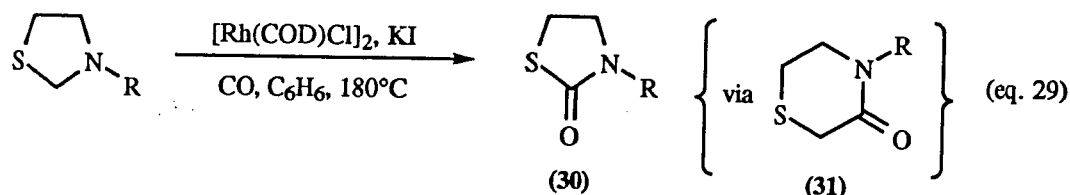

Even *acyclic* systems containing 1, 3-N, S functionality could be carbonylated.^{55b} This carbonylation reaction is also sensitive to the substituents on nitrogen with cyclic amines (i.e. R₂ = -(CH₂CH₂CH₂CH₂CH₂)- or -(CH₂CH₂OCH₂CH₂)-) being completely unreactive. A benzylic substituent on sulfur was found to be essential for the success of the carbonylation.

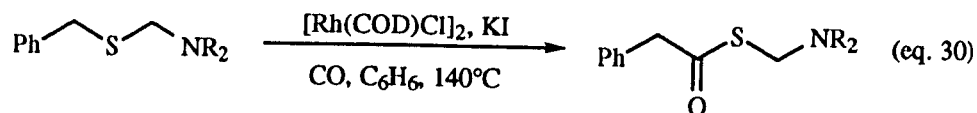

This reaction represents the first example of the insertion of carbon monoxide into an acyclic carbon-heteroatom bond that does not involve π -allyl intermediates, and brings us to the final section of the introduction, the carbonylation of π -allyl metal complexes.

1.2.3.3 The Insertion of Carbon Monoxide into Carbon Heteroatom Bonds in π -Allyl Systems

The third and final example in the category of CO insertion/substitution reactions is the carbonylation of π -allyl palladium complexes. Tsuji and Dent independently reported the first examples of the carbonylation of allylic compounds in 1964.⁵⁶ In his pioneering study, Tsuji described the PdCl₂ catalyzed carbonylation of allyl chlorides, ethers, alcohols and acetates (equation 31). The reactions proceeded as shown in equation 31 except with allyl alcohol. In this case allyl butenoic ester was isolated from attack of a second molecule of allyl alcohol on the π -allyl palladium intermediate (equation 32). The yields of these reactions varied from 18 to 80 % depending on the nature of X.

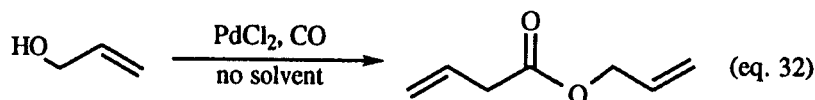
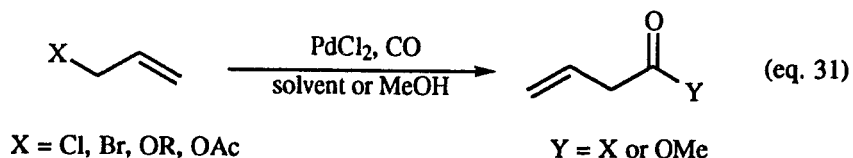

The reaction begins with the formation of a π -allyl intermediate by oxidative addition of the C-X bond and is facile for allyl chlorides, bromides and iodides but the more synthetically important⁵⁶ allyl alcohol derivatives such as acetates and ethers require more severe conditions. Murahashi recently reported that when the allyl alcohols were derivatized as phosphates, the carbonylation occurred under extremely mild conditions (1 atm CO, 1 mol % catalyst, 50 °C, 5h). Furthermore, he found that by adding sodium bromide to the reaction, allyl acetates could be carbonylated under equally mild conditions.

In a unique approach, Tsuji incorporated the nucleophile into the leaving group by using an allyl carbonate.⁵⁸ Thus *in situ* decarboxylation of $-\text{OCO}_2\text{R}$ generates $-\text{OR}$ which attacks the carbonylated π -allyl intermediate producing the desired ester. This method has the advantages of both direct carbonylation (eliminating the need for the addition of stoichiometric or greater amounts of the nucleophile by incorporating it into the starting material) and of substitutive carbonylation (mild reaction conditions) (equation 33). One disadvantage is the concomitant formation of allyl ethers along with the desired esters. These form by reductive elimination of the allyl and OR ligands *prior* to carbonylation.

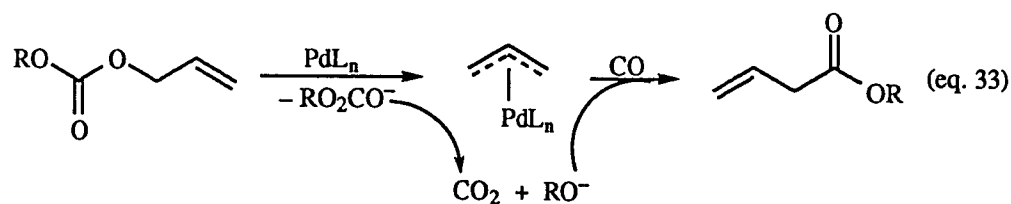

A possible mechanism for this reaction is shown in equation 34. Support for this mechanism was advanced by the work of Yamamoto et al. who showed that acyl palladium complexes can be isolated from the carbonylation of π -allylpalladium bromide complexes.⁵⁹ As in the other carbonylations that we have discussed, the mechanism shown below has been disputed.⁶⁰

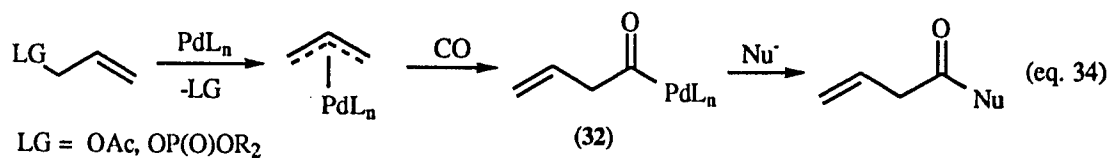

π -Allyl systems are known to be poor substrates for carbonylation because of the delocalized nature of the metal-carbon bond, so it has been proposed that the product is not formed through a palladium acyl complex (32), but by generation of a metal

carboxylate (33) via attack on a coordinated CO and reductive elimination of the allyl and carboxyl ligands as shown in equation 35. (An analogous mechanism for the cobalt-catalyzed carbonylation of butadiene was previously discussed, see Scheme 6.)

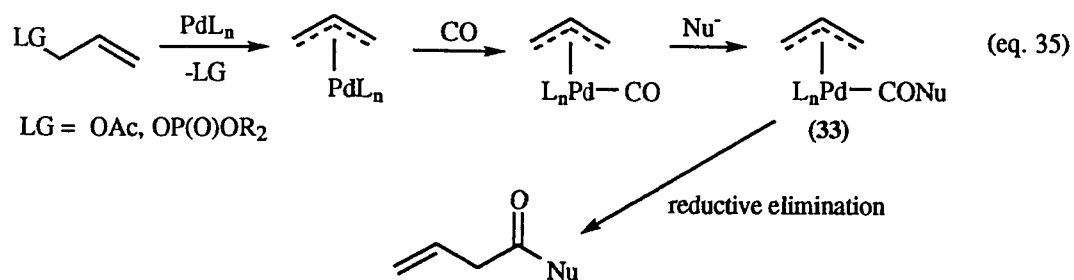

As previously demonstrated in this introduction, there is considerable evidence for both "hydride" and "carboxylate" type mechanisms. Subtle changes in reaction conditions and ancillary ligands on the metal catalyst may have a profound influence on the selectivity and mechanism of this carbonylation reaction.

Chapter Two: The Hydroformylation of Vinylsilanes

2.1 Introduction

As mentioned in the introduction, the hydroformylation reaction is one of the most important industrial processes employing transition metal catalysts. Although hydroformylation is a simple, often highly selective reaction, it has not found many applications in organic synthesis. This is presumably because most organic chemists associate the reaction with the high pressures and temperatures required for the early cobalt catalyzed processes. Some examples have been compiled in a 1980 review⁶¹ which details the use of hydroformylation to prepare vitamins, terpenes and other related compounds. The preparation of an intermediate in the synthesis of guaiazulene⁶² using hydroformylation is shown in Scheme 12.

Scheme 12: Hydroformylation in the Preparation of Guaiazulene

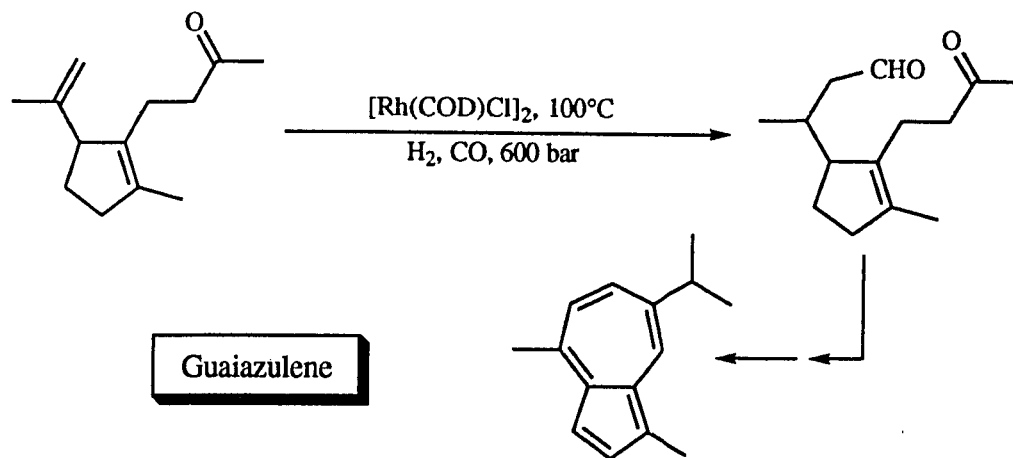

Hydroformylation has, however, found more applications in the synthesis of compounds difficult to prepare by *conventional* methods. For example, Ojima has prepared a series of fluorinated compounds by the hydroformylation of readily available

alkenes.⁶³ This technique is extremely useful for the incorporation of CF_3 or C_6F_5 groups during a synthesis since aldehydes are very reactive towards a variety of nucleophiles (Scheme 13, R^* = molecule to which fluorinated group is to be attached).

Scheme 13: Hydroformylation of Fluorinated Alkenes.

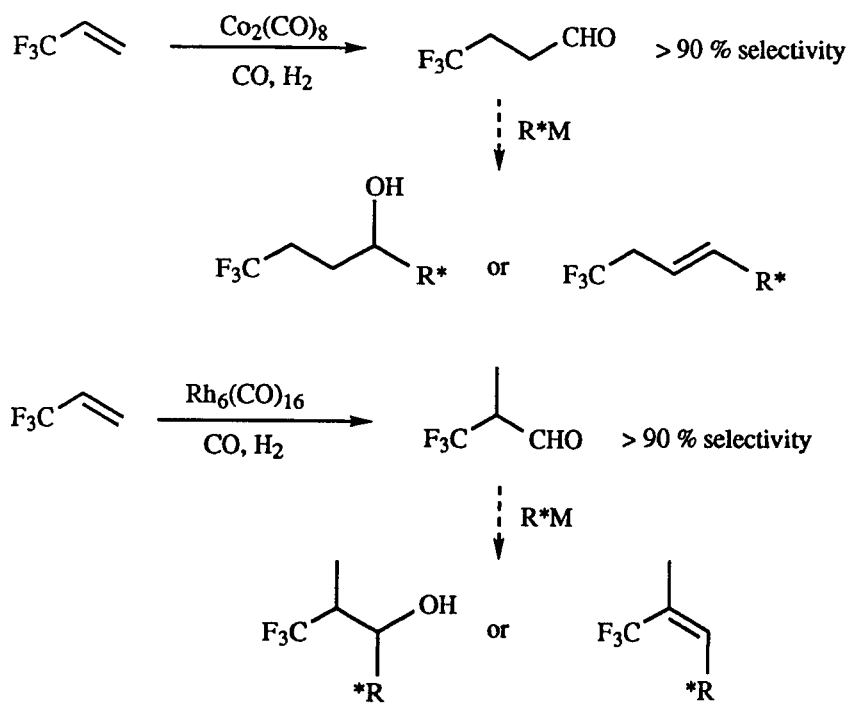

As shown in Scheme 13, Ojima found that by simply changing the catalyst from cobalt to rhodium, either the branched or the linear isomer could be obtained with excellent regioselectivity. In fact, 3,3,3-trifluoropropene (TFP) displayed a much greater selectivity with simple metal carbonyls than did propene itself. In the $\text{Co}_2(\text{CO})_8$ catalyzed hydroformylation, 93% selectivity for the linear isomer was observed using TFP compared to 80% with propene. Hexarhodium hexadecacarbonyl yielded the branched isomer in the hydroformylation of TFP (96%) while a 1 : 1 mixture was obtained when propene was used as the substrate.

The addition of triphenylphosphine to these cobalt and rhodium systems considerably decreases the catalytic activity and, for the fluorinated systems, slightly increases the selectivity for the *branched* isomer. This is in marked contrast to the effect of triphenylphosphine on the non-fluorinated systems (see Chapter 1).⁶³

Another example of the elaboration of commercially available alkenes into compounds difficult to prepare by other routes is the hydroformylation of vinyl silanes. Takeuchi has made a considerable contribution to the study of the hydroformylation and hydroesterification of vinylsilanes.⁶⁴⁻⁶⁶ In the hydroesterification of vinyltrimethylsilane, Takeuchi reported that either the linear or the branched isomer could be obtained selectively in excellent yield (GC) by simply switching the catalyst from palladium to cobalt.⁶⁵ However, such control was not possible in the related hydroformylation reactions.⁶⁶ The branched aldehyde could only be obtained as a 1 : 1 mixture with the linear isomer. In order to selectively prepare the linear aldehyde in the rhodium-catalyzed hydroformylation, the addition of very large excesses of phosphine (50–80 equiv) was required. Dicobalt octacarbonyl catalyzed hydroformylations did yield the linear aldehyde selectively without the addition of phosphine ligands, but the conditions required were more severe. Despite these facts, Takeuchi's research has shown that hydroformylation is a useful and convenient method for the preparation of these potentially useful bifunctional compounds from commercially available precursors (equations 36 and 37).

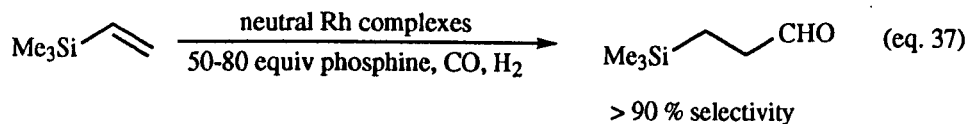
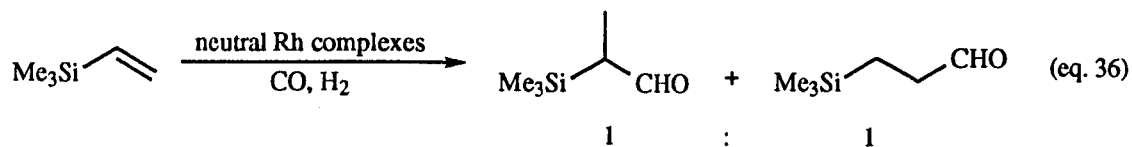

Both α - and β -silylaldehydes (branched and linear isomers, respectively) are potentially useful reagents in organic synthesis. *Cis* or *trans* olefins could be prepared from the α -silyl isomers following the protocol of Hudrlík et al. (Scheme 14).⁶⁷ The β -isomer could also be useful as a 1, 3-dipole since silicon is a latent carbanion.

Scheme 14: The Utility of α - and β -Silylaldehydes.

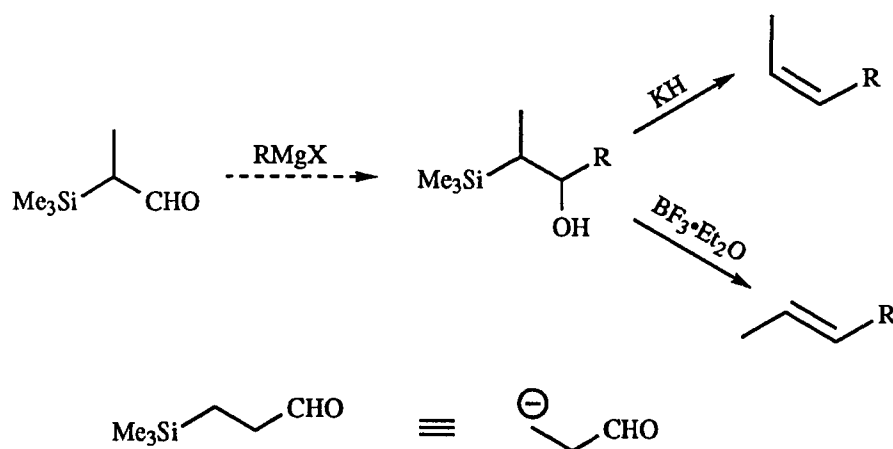

There are several other routes to β -trialkylsilylaldehydes including protection of the aldehyde of acrolein, Pt-catalyzed hydrosilylation and subsequent deprotection.⁶⁸ The oxidation of 1,3-silanols with $\text{AgNO}_3/\text{Celite}$ has also been used to prepare β -triphenylsilylaldehydes (see equations 38 and 39).⁶⁹ The $\text{Ni}(\text{CO})_4$ promoted addition of Et_3SiH to acrolein was also used for the synthesis of 2-triethylsilylpropanal.⁷³

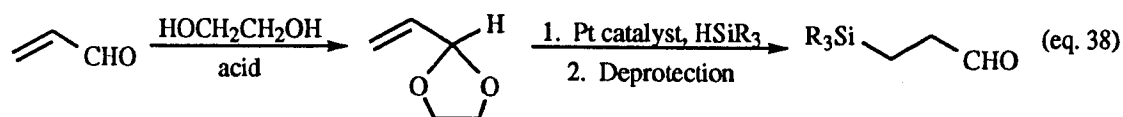

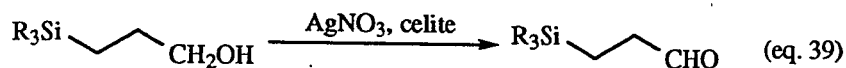

α -Silylaldehydes can also be prepared by oxidation of the corresponding 1, 2-silanols, but only when the silyl substituents are bulky. Thus α -triisopropylsilylaldehydes have been prepared by oxidation of 1, 2-silanols with NCS.⁶⁹ Hudrlik et al. have reported that they have not been able to prepare trimethylsilylacetaldehyde or simple α -trimethylsilyl (*n*-alkyl) aldehydes by oxidation of β -hydroxysilanes.⁶⁷

Rearrangements of silyloxiranes can also be used for the synthesis of α -silylaldehydes. α -Triisopropylsilyl and α -triphenylsilylaldehydes have been prepared by rearrangements of the corresponding oxiranes (equation 40).⁷⁰ This method is not applicable to the synthesis of less bulky silanes, especially α -trimethylsilylaldehydes which are notoriously difficult to prepare and isolate.⁷¹ Attempts to prepare the trimethylsilyl or even the dimethylphenylsilyl analogs using Eisch's rearrangement method reportedly failed.^{71b} Hudrlik also reported the failure of this technique for the synthesis of α -trimethylsilyl (*n*-alkyl) aldehydes.⁶⁷

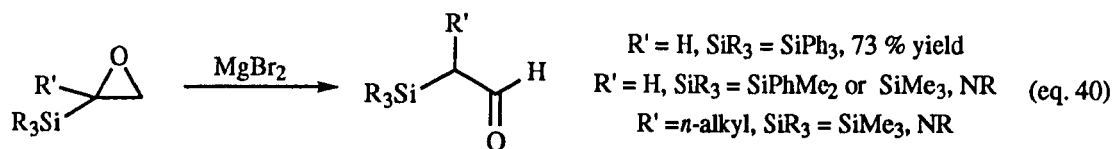

Aside from Takeuchi's report⁶⁶, (see equations 36 and 37), in 1952 Burkhard and Hurd reported the preparation of a 1 : 1 mixture of 2- and 3-trimethylsilylpropanal in low yield (ca. 16%) by the $\text{Co}_2(\text{CO})_8$ catalyzed hydroformylation of vinyltrimethylsilane.⁷²

Enders reported the preparation of α -silylaldehydes (specifically 2-(*t*-BuMe₂Si)-octanal and 2-(*t*-BuMe₂Si)-3-phenylpropanal) by deprotonation of SAMP and RAMP hydrazones and trapping with TBDMSCl. Subsequent conversion of the hydrazone to the aldehyde was affected using ozone.^{74a} Jackson et al.⁷⁵ have reported that this procedure

failed in their hands, as did a modification of a method reported by Meyers.^{74b} The *in situ* preparation of α -trimethylsilylaldehydes has been reported⁷⁶ and Duhamel very recently described the isolation of 2-trimethylsilylpentanal and butanal by the sequence shown in equation 41.⁷⁷

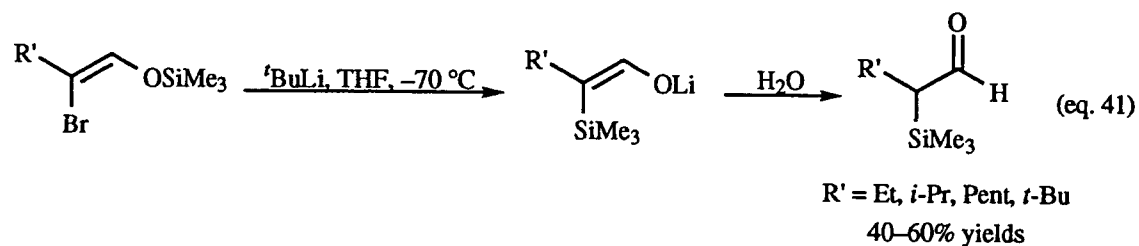

Considering the dearth of conventional methods for the preparation of α -silylaldehydes, and the potential demonstrated by metal catalyzed processes, we embarked on a study of the hydroformylation of vinylsilanes. We hoped to find a suitable method for the preparation branched aldehyde selectively, since the α -selective hydroformylation of vinylsilanes had not been reported. Furthermore, these compounds are difficult to make by conventional methods and could be useful reagents for organic synthesis. Finally, it was also hoped that a method could be found for the preparation of the linear isomer that did not require the addition of 50–80 equivalents of phosphine. During the course of this research, we examined zwitterionic and cationic rhodium complexes, as well as iridium and cobalt complexes.

2.2 Results and Discussion

2.2.1 Rhodium Catalyzed Hydroformylation Reactions

The first rhodium catalyst we examined was the zwitterionic rhodium complex $[\text{Rh}(\text{COD})\eta^6\text{-C}_6\text{H}_5\text{-BPh}_3]$, (6).¹⁸ This complex, which will be denoted as Rh^{zw} , was shown by Alper and Amer to be an active catalyst for the hydroformylation of styrene.^{18a} The reaction was highly selective for the branched isomer (97 : 3), under mild conditions (200 psi of syn gas and 50 °C) and required no phosphine additives. It was subsequently shown by Alper and Zhou⁷⁸ that Rh^{zw} catalyzes the hydroformylation and silylhydroformylation of a variety of compounds.

Vinyltrimethylsilane was chosen as the least sterically hindered vinyltrialkylsilane, and the most likely to give the branched isomer selectively. Thus it was subjected to hydroformylation under 1000 psi of a 1 : 1 mixture of CO and H₂ at 100°C. Analysis of the reaction proved difficult since the aldehydes were sensitive to oxygen, silica gel chromatography and certain types of GC packing material. Even standing overnight in the freezer led to considerable decomposition. Finally, it was found that GC analysis on a DB4 capillary column (non-polar) permitted assessment of the branched to linear ratios. These ratios were confirmed by examination of the ¹H NMR spectra of the crude mixtures after removal of the volatiles (benzene and starting material) on the rotary evaporator.

Under the conditions described above, (500 psi CO, 500 psi H₂, 100 °C), less than half (46%) of the aldehyde produced was branched. Not surprisingly, the addition of a variety of phosphines and amines did not improve the selectivity for the branched isomer. Finally, it was discovered that by decreasing the total amount of CO in the system, the branched isomer could be obtained as the major product. The best results were obtained by also increasing the amount of hydrogen in the gas mixture from 1 : 1 (H₂ : CO) to 2 : 1 giving the branched isomer as 70% of the total aldehyde! This was the first time, to the best of our knowledge, that an α -selective hydroformylation of vinylsilanes had been affected.⁷⁹ We hoped that further increasing the amount of hydrogen in the gas mixture would improve the branched to linear ratio, but even slightly more than 2 : 1 H₂ : CO

caused precipitation of metallic rhodium. Changing other parameters did not improve the branched to linear ratio. The results of the pressure studies are shown in Table 4.

Table 4: Effect of Pressure on the Branched to Linear Ratio in the Hydroformylation of Vinyltrimethylsilane.^a

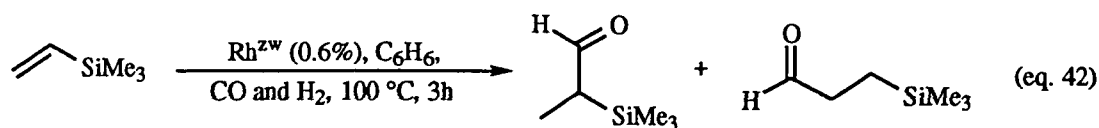

Entry	H ₂ Pressure (psi)	CO Pressure (psi)	Branched : Linear
1	500	500	46 : 54
2	100	100	60 : 40
3	50	50	57 : 43
4	130	70	70 : 30
5	150	50	catalyst decomposition
6	140	60	catalyst decomposition

^a Reaction conditions: 3.2 mmol substrate, 3 mL dry distilled benzene, 0.019 mmol catalyst (0.6%), 100 °C, 3h.

After determining that the zwitterionic complex was in fact able to catalyze the α -selective hydroformylation of vinyltrimethylsilane, we examined the reaction with respect to isolated yield. If our method was to be synthetically useful, isolated yields would be important. Due to the sensitivity of the aldehydes to chromatography, isolation was accomplished by a reduced pressure distillation using a Kugelrohr apparatus. Using this procedure, approximately 30% isolated yield was obtained regardless of the reaction time, presumably due to the volatility of the aldehyde products (bp \approx 130 °C).⁶⁶ An undetermined amount of the product loss is due to the production of another unidentified high boiling compound(s). Since the starting material was low boiling (50 °C), it was also

possible that some of it was lost while the autoclave was being flushed. The standard procedure employed throughout this work (see Experimental Section) involved flushing the autoclave and its contents three times with 70 psi of carbon monoxide. In an attempt to decrease the losses of the starting material, the autoclave was cooled prior to the flushing procedure, but this did not improve the yield.

Examination of the reaction in benzene- d_6 indicated that the isolated yields were reasonably close to the NMR yields (Table 5). The conversions were also measured in reactions which were run in deuterated solvents, and were consistently >70% even though the yields were only 20–55%. This indicates that the starting material is being consumed by a competing process or lost during flushing of the autoclave. Furthermore, the addition of 2 equivalents of triphenylphosphine gave the aldehydes in 55% yield with 100% conversion. (In this experiment, the linear isomer was almost 90% of the aldehyde produced.) Subsequent experiments showed that the addition of triphenylphosphine to the Rh^{ZW} catalyzed hydroformylation of triethylvinylsilane gave the desired aldehyde in virtually quantitative yield (*vide infra*). It is therefore likely that 55%, (entry 7) is the maximum yield for the hydroformylation of vinyltrimethylsilane.

Table 5: The Rh^{zw} Catalyzed Hydroformylation of Vinyltrimethylsilane.^a

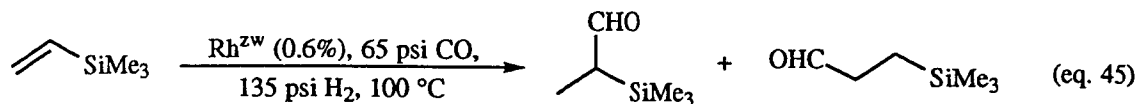

Entry	Time (h)	Solvent	% Yield ^b	Branched : Linear ^c
1	4	benzene	27	56 : 44
2	3	benzene	34	57 : 43
3	3	benzene- <i>d</i> ₆	29 ^d	65 : 35
4	1.5	benzene	20	70 : 30
5	1.5	benzene- <i>d</i> ₆	23 ^d	65 : 35
6 ^e	1.5	benzene- <i>d</i> ₆	17 ^{d,e}	71 : 29
7 ^f	1.5	benzene- <i>d</i> ₆	55 ^{d,f}	11 : 89

^aReaction conditions: 3.2 mmol substrate and 3 mL dry distilled benzene or 1.6 mmol substrate and 1.5 mL dry benzene-*d*₆, 0.019 mmol catalyst (0.6%), 65 psi CO, 135 psi H₂, 100 °C. ^bIsolated, of both linear and branched aldehydes. ^cNot including branched aldehyde lost as enol silyl ether. ^dNMR yield vs internal standard (PhOMe). ^eIn this experiment, 0.008 mmol (0.3%) of catalyst was used. ^fIn this experiment, 2 equiv. of PPh₃ were added.

The crude GC's of the hydroformylation reaction and the NMR experiments in deuterated solvents revealed the presence of a small amount ($\leq 6\%$) of another compound which we tentatively assigned as the enol silyl ether resulting from a Brook rearrangement of the α -silylaldehyde.⁸⁰ By using vinyltriethylsilane in place of vinyltrimethylsilane, we were able to isolate and identify this compound by comparison with authentic material prepared using a route described by Danishefsky (equations 44 and 45).⁸¹

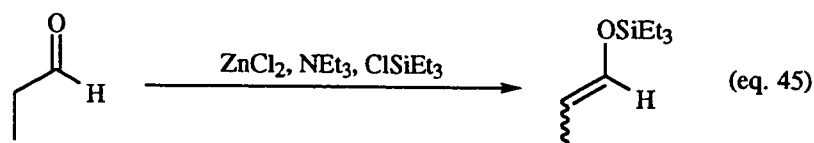
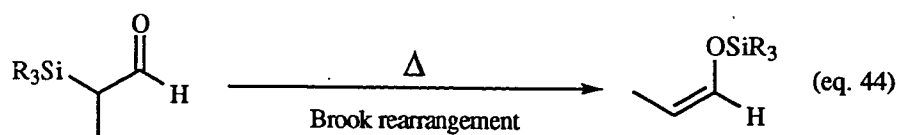

Although the Danishefsky procedure gave a mixture of *cis* and *trans* isomers, we observed > 90% selectivity for the *cis* isomer in the Brook rearrangement of the α -silylaldehyde. The same preference for the *cis* enol silyl ether was previously observed by Jackson et al. in their studies on the hydroformylation of 1, 2-disubstituted vinyl silanes. In their system, the α -silylaldehydes were not observed, but instead were completely isomerized to the corresponding enol silyl ethers (80–98% *cis*).⁷⁵

The use of vinyltriethylsilane also permitted the calculation of accurate GC conversions, since the signal of the starting material could be separated from the solvent. With this substrate, the isolated yields were also much improved. After 4 hours, the isolated yield was 66% after purification by reduced pressure distillation. Unfortunately, the increased yield was obtained at the expense of the branched selectivity. The added bulk of the ethyl groups caused a dramatic shift in the selectivity such that the linear product was obtained as the major isomer (60–70% of the total aldehyde *not including* the branched isomer lost as the enol silyl ether). As in the vinyltrimethylsilane case, an unidentified high boiling product(s) was observed. This product likely accounts for the difference in the conversions and yields seen in Figure 2. A simple thermal decomposition of the aldehyde products is not responsible because the iridium catalyzed hydroformylation reactions which will be discussed subsequently are run at the same temperature and this product is not observed (*vide infra*).

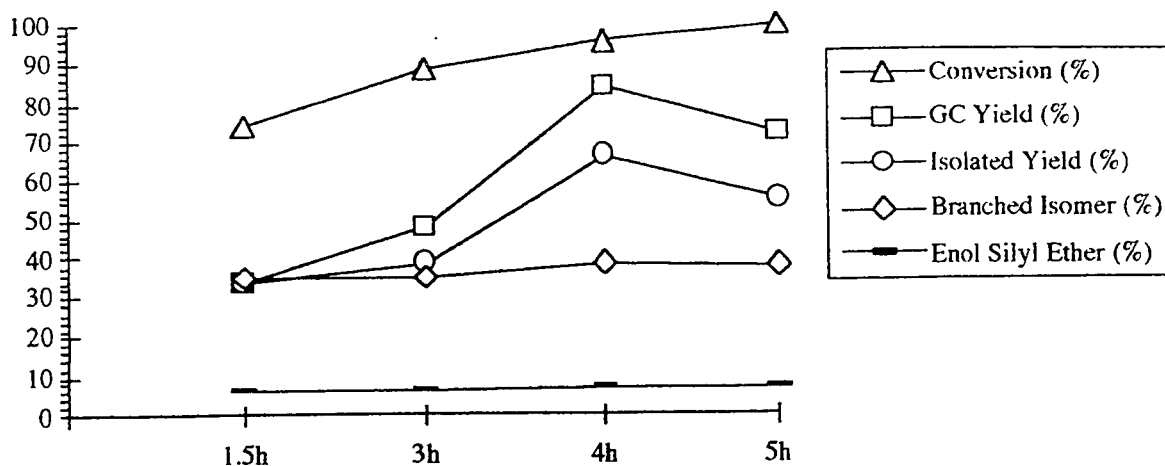
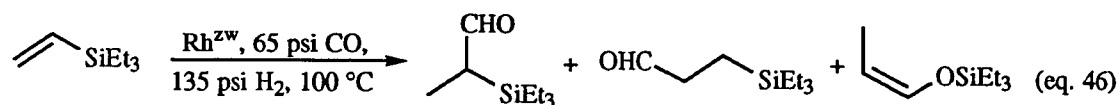

Figure 2: Rh^{2w} Catalyzed Hydroformylation of Vinyltriethylsilane in Benzene.

As can be seen from Figure 2, the amount of the branched isomer remained constant at about 35%. The amount of enol silyl ether produced in the reaction was also constant at ca. 6%. Since only the branched isomer undergoes the 1, 3-silicon shift to generate the enol silyl ether, the amount of the branched aldehyde produced is actually closer to 40%. When the hydroformylation reaction was run in different solvents, different amounts of the rearrangement product were detected. In fact, the zwitterionic complex is an effective hydroformylation catalyst in all the solvents we examined including ethers, aromatic hydrocarbons and chlorocarbons. The reaction profile (yield, selectivity, conversion, amount of 1, 3-Si shift) in these solvents is shown in Table 6. The hydroformylation reactions were stopped after 1.5 h in order to accurately compare the more and less efficient systems.

Table 6: Rh^{zw} Catalyzed Hydroformylation of Vinyltriethylsilane in Various Solvents.^a



Entry	Solvent	Yield (%) ^b	Conv. (%)	1, 3-Si Shift (%)	B : L ^c	B : L ^d
1	C ₆ H ₆	34	74	6	35 : 65	45 : 55
2	C ₆ H ₅ CH ₃	53	95	8	34 : 66	43 : 57
3	C ₆ H ₅ CF ₃	53	95	11	28 : 72	40 : 60
4	C ₆ H ₅ OMe	34	nd ^e	6	28 : 72	39 : 61
5	Et ₂ O	27	32	4	30 : 70	39 : 61
6	THF	28	38	4	39 : 61	47 : 53
7	CH ₂ Cl ₂	32	74	10	23 : 77	41 : 59
8	CHCl ₃	38	95	20	5 : 95	38 : 62

^aReaction conditions: 3.2 mmol substrate, 3 mL dry distilled solvent, 0.019 mmol catalyst (0.6%), 65 psi CO, 135 psi H₂, 100 °C, 1.5h. ^bOf both linear and branched aldehydes, determined by GC vs. added internal standard (*m*-dimethoxybenzene). ^cB : L = Branched : Linear, not including branched aldehyde lost as enol silyl ether. ^dB : L = Branched : Linear, including branched aldehyde lost as enol silyl ether. ^end = not determined due to interference from the solvent peak.

Of those solvents examined, toluene and α,α,α -trifluorotoluene were the best, giving 53% yield after only 1.5 hours. The GC yield was slightly lower in the ethereal solvents examined, but most interesting was the increased enol silyl ether observed in the halogenated solvents examined (up to 20% in CHCl₃). When this loss of the branched aldehyde is taken into consideration, it is obvious that the amount of the branched isomer produced in the hydroformylation is almost the same (40–45%) regardless of the solvent.

The hydroformylation of vinyltriethylsilane was also examined using a commercially available cationic rhodium catalyst, $[\text{Rh}(\text{COD})_2]^+\text{BF}_4^-$, which will be denoted as Rh^+ . This bronze coloured solid could also be prepared by treatment of $[\text{Rh}(\text{COD})\text{Cl}]_2$ with $\text{Et}_3\text{O}^+\text{BF}_4^-$ in the presence of excess cyclooctadiene. Unlike those reactions described in Table 6 with Rh^{zw} , the hydroformylation reactions catalyzed by Rh^+ were quite sensitive to the solvent used. The results are shown in Table 7.

Table 7: Rh^+ Catalyzed Hydroformylation of Vinyltrimethylsilane in Various Solvents.^a

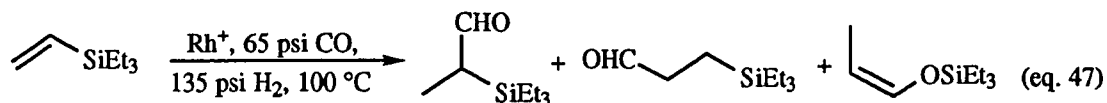

Entry	Solvent	Time (h)	Yield (%) ^b	Conv. (%)	1, 3-Si Shift (%)	B : L ^c	B : L ^d
1	C ₆ H ₆	3	50	84	3	35 : 65	39 : 67
2	C ₆ H ₆	1.5	40	82	6	33 : 67	42 : 58
3	PhCH ₃	1.5	31	78	6	29 : 71	41 : 59
4	PhCF ₃	1.5	17	37	nd ^e	19 : 81	—
5	PhOMe	1.5	25	nd ^e	5	20 : 80	33 : 67
6	Et ₂ O	3	NR	—	—	—	—
7	CHCl ₃	3	NR	—	—	—	—

^aReaction conditions: 3.2 mmol substrate, 3 mL dry distilled solvent, 0.019 mmol catalyst (0.6%), 65 psi CO, 135 psi H₂ 100 °C. ^bOf both linear and branched aldehydes, determined by GC vs. added internal standard (*m*-dimethoxybenzene). ^cB : L = Branched : Linear, not including branched aldehyde lost as enol silyl ether. ^dIncluding branched aldehyde lost as enol silyl ether. ^end = not determined

Table 7 illustrates that there is no reaction when the Rh^+ catalyzed hydroformylation is attempted in non-aromatic solvents such as diethyl ether and chloroform (see entries 6 and 7). This is in stark contrast to the reactions of Rh^{zw} in these solvents (see Table 6,

entries 5 and 8). In these reactions, the aldehyde products were obtained in 27 and 38% yields respectively after 1.5h. Even in those reactions that worked, the difference between Rh^{zw} and Rh^+ is obvious. Toluene and PhCF_3 were the best solvents (Table 6, entries 2 and 3) in the Rh^{zw} systems, but in the Rh^+ catalyzed hydroformylations, a slightly lower yield was obtained in toluene (31%, Table 7, entry 3) and PhCF_3 gave a much lower yield (17%, Table 7, entry 5).

In order to explain the unique solvent dependence in the Rh^+ catalyzed hydroformylation reactions, we postulated that the aromatic solvent acts as a ligand for the low-ligated rhodium. With low concentrations of carbon monoxide (65 psi) and a bulky, weakly coordinating substrate, rhodium may lack the stabilizing ligands necessary to prevent decomposition to metallic rhodium.⁸² It is known that co-ordination to an arene can help to stabilize low ligated rhodium species. Halpern et al. showed that the complex $[\text{Rh}(\text{DPPE})]^+\text{BF}_4^-$ exists as a dimer in which each rhodium is η^6 -co-ordinated to one arene of the PPh_2 unit from DPPE.^{82e} Arresta subsequently showed that in the corresponding BPh_4^- salt $[\text{Rh}(\text{DPPE})]^+\text{BPh}_4^-$, it is one of the arenes of the counterion which coordinates to the rhodium, giving a monomeric complex.^{82f}

For the zwitterionic rhodium complex, $[\text{Rh}(\text{COD})]^+\text{BPh}_4^-$, it has been shown by X-ray crystallography that the counterion is also η^6 -coordinated in the solid state. ^1H NMR and ^{13}C NMR spectra of Rh^{zw} have confirmed that this structure is also present in solution (at room temperature in the absence of other ligands).¹⁸ Unlike $[\text{Rh}(\text{DPPE})]^+\text{X}^-$, the COD ligand does not co-ordinate to rhodium during the catalysis. Therefore it is likely that when the hydroformylation is run in the absence of stabilizing ligands, η^6 -co-ordination of Rh^+ to the tetraphenylborate counterion during the reaction is possible.^{18,19,82} Furthermore, this effect may also explain the solvent dependence observed in the Rh^+ catalyzed hydroformylations. As will be shown in Chapter 3, we attempted to observe intermediates which had a coordinated arene ligand by running the reaction in high pressure NMR tubes, but this was unsuccessful.

Since we felt that the lack of stabilizing ligands and decomposition of the rhodium complex was responsible for the lack of activity of Rh^+ in non-aromatic solvents, we examined the same reaction in the presence of various ligands. Phosphines and carbon monoxide are commonly used as ligands for the platinum group metals.⁸³ If the lack of reactivity of Rh^+ in non-aromatic solvents is related to a lack of stabilizing ligands, the addition of phosphines should restore activity. In fact, although Rh^+ does not catalyze the hydroformylation of vinyltriethylsilane in diethyl ether, when 1 equivalent of triphenylphosphine (per rhodium atom) was added to the reaction mixture, the hydroformylation products were obtained in 93% yield! A significant increase in the yield was also obtained upon the addition of triphenylphosphine to the hydroformylations run in benzene (from 40 to 93%, compare entries 3 and 4 in Table 8).

Table 8: The Effect of Phosphine Ligands on the Rh^{zw} and Rh^+ Catalyzed Hydroformylation of Vinyltriethylsilane.^a

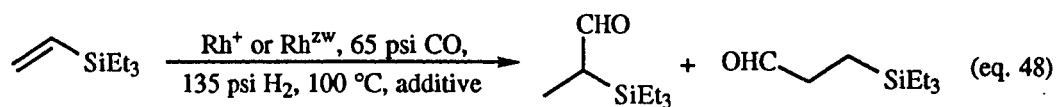

Entry	Catalyst	Time (h)	Solvent	Additive	% Yield ^b	B : L ^c
1	Rh^+	3	Et_2O	—	NR ^d	—
2	Rh^+	1.5	Et_2O	PPh_3 (1 equiv.) ^e	93	20 : 80
3	Rh^+	1.5	C_6H_6	—	40	33 : 67
4	Rh^+	1.5	C_6H_6	PPh_3 (1 equiv.)	93	22 : 78
5	Rh^{zw}	1.5	C_6H_6	—	34	35 : 65
6	Rh^{zw}	1.5	C_6H_6	PPh_3 (1 equiv.)	98 (91)	20 : 80

^aReaction conditions: 3.2 mmol substrate, 3 mL of dry distilled solvent, 0.019 mmol catalyst (0.6%), 65 psi CO, 135 psi H_2 , 100 °C. ^bGC yields of both linear and branched aldehydes (*m*-dimethoxybenzene), isolated yields in brackets. ^cB : L = Branched : Linear, not including branched aldehyde lost as enol silyl ether. ^dNR = no reaction. ^eper rhodium atom.

Even in reactions catalyzed by Rh^{zw} , the addition of PPh_3 had a beneficial effect (compare entries 5 and 6 in Table 8). In fact, the reaction profiles of the three examples where 1 equiv of PPh_3 was added were identical within experimental error (entries 2, 4 and 6). This suggests that PPh_3 displaces the coordinated benzene in the $\text{Rh}^+/\text{C}_6\text{H}_6$ system or the coordinated BPh_4^- counterion in the Rh^{zw} reaction. The striking similarities of the phosphine and non-phosphine containing systems provides further evidence for the coordination of the arene solvent in the Rh^+ systems and of the arene counterion in the Rh^{zw} systems.

As expected, the linear isomer predominated in the experiments with added phosphine giving a branched to linear ratio of 20 : 80. If two equivalents of PPh_3 were added (per rhodium atom), the selectivity became even more favourable for the linear isomer, so that it was 93% of the total aldehyde (Table 9, entry 1). Increasing the amount of PPh_3 added to 4 equivalents did not improve the amount of the linear isomer (Table 9, entries 1-3).

The added PPh_3 also affected the activity of the rhodium-catalyzed systems. As shown in Table 9, the hydroformylation of vinyltriethylsilane is much more facile after the addition of PPh_3 . Without any additives, 2- and 3-triethylsilylpropanal were obtained in a total isolated yield of 34% after 1.5 hours. With the addition of only 1 equiv of PPh_3 , the isolated yield increased to 91% after 1.5 hours and with the addition of 4 equiv of PPh_3 , the same yield can be obtained after only 30 minutes (Table 9, entry 2). The reaction can also be run at a lower temperature giving a slightly lower yield after 1.5 hours (entry 3). Finally, the addition of 2 equivalents of pyridine had little or no effect on the hydroformylation reaction (entry 4).

Table 9: The Effect of Excess Phosphine on the Rh^{zw} Catalyzed Hydroformylation of Vinyltriethylsilane.^a

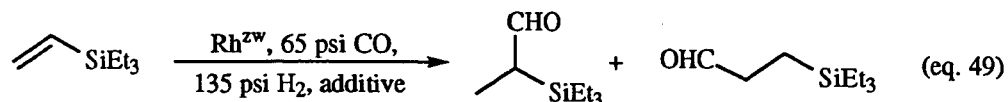

Entry	Time (h)	Temperature (°C)	Additive	% Yield ^b	B : L ^c
1	1.5	100	PPh ₃ (2 eq.) ^d	97	7 : 93
2	0.5	100	PPh ₃ (4 eq.)	100 (90)	7 : 93
3	1.5	65	PPh ₃ (4 eq.)	86	7 : 93
4	1.5	100	pyridine (2 eq.)	34	32 : 68

^aReaction conditions: 3.2 mmol substrate, 3mL dry distilled benzene, 0.019 mmol catalyst (0.6%), 65 psi CO, 135 psi H₂. ^bGC yields of both linear and branched aldehydes (*m*-dimethoxybenzene), isolated yields in brackets. ^cB : L = Branched : Linear, not including branched aldehyde lost as enol silyl ether. ^dper rhodium atom.

The shift in the isomer ratio towards the linear isomer with the addition of PPh₃ has considerable precedent in the literature. Takeuchi showed that 50–80 equivalents of PPh₃ or DPPB were required to obtain >90% of the linear isomer in the hydroformylation of vinyltrimethylsilane with his system.⁶⁶ It was thus surprising to us that adding as little as 2 equivalents of PPh₃ to the Rh⁺ or Rh^{zw} systems gave 93% selectivity towards the linear isomer. As discussed in the general introduction, it has been postulated that improved selectivity for the linear aldehyde observed with increased levels of phosphine is due to the action of a species containing more than one phosphine in the coordination sphere of rhodium (i. e. compound 4, equation 5). It is therefore possible that there is considerably less dissociation of phosphine ligands in the cationic systems.

Another technique for increasing the linear selectivity in the hydroformylation of silyl olefins is to increase the bulkiness of the silyl substituents. In fact, 95% of the linear isomer can be obtained in the Rh^{zw} catalyzed hydroformylation of commercially available

vinyltriphenylsilane, without the addition of any phosphine. Using 0.6% Rh^{zw}, commercially available vinyltriphenylsilane was hydroformylated in 55% isolated yield. The 5% of the branched isomer could be easily removed by chromatography on silica gel.

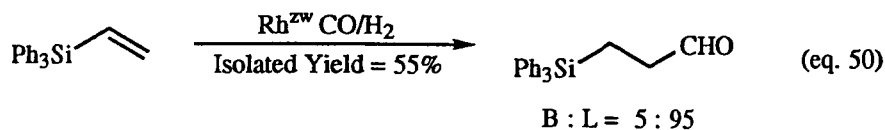

Finally, the hydroformylation of vinyltriethylsilane catalyzed by Rh⁺ could also be affected in non-aromatic solvents if the carbon monoxide pressure was increased. Thus if the hydroformylation was run under the standard conditions as indicated in equation 48 and Table 8 but the CO : H₂ ratio was increased to 7 : 1 (total pressure = 800 psi), the reaction proceeded to give the linear aldehyde exclusively in 52% isolated yield, along with 17% of the enol silyl ether. This indicates that some of the branched aldehyde had in fact been produced. The fact that Rh⁺ is an effective catalyst in non-aromatic solvents when higher CO pressures are used (or when phosphines are added) supports our postulation that the lack of stabilizing ligands is responsible for the lack of activity of Rh⁺ in non-aromatic solvents at low CO pressures.

2.2.2 Results and Discussion: Iridium Catalyzed Hydroformylation Reactions

When the hydroformylation of vinyltrimethylsilane was attempted with commercially available [Ir(COD)₂]⁺BF₄⁻ as the catalyst using the standard conditions developed for the rhodium systems, (65 psi CO, 135 psi H₂, 100 °C, 3h), GC analysis of the crude reaction mixture indicated that there was virtually no reaction. Repeating the hydroformylation with vinyltriethylsilane as the substrate showed that the major product of the reaction was not in

fact unreacted starting material, but tetraethylsilane from direct reduction of the starting material. Although there was less than 10% hydroformylation, we decided to examine this system further because the selectivity for the linear isomer was excellent (90–100%). In fact, by simply increasing the P_{CO} (effectively decreasing the amount of H_2 in the gas mixture), the hydrogenation could be suppressed (equation 51).

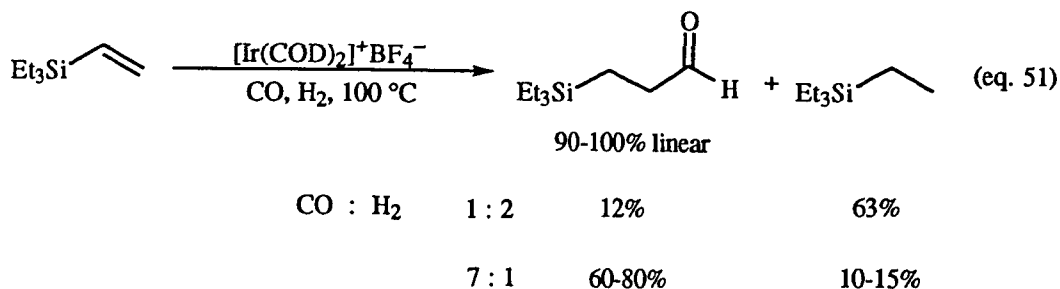

The best results were obtained using a 7 : 1 ratio of CO : H₂ (total pressure = 800 psi) which gave 80% GC yield and 97% selectivity for the linear isomer (Table 10, entry 6). Further increasing the gas ratio to 10 : 1 (CO : H₂) gave the same ratio of hydroformylation to hydrogenation (ca. 85 : 15) but the conversion was considerably lower and only 20% of the aldehyde (100% linear) was observed by GC (entry 5). These results and others are compiled in Table 10 on the following page.

Table 10: $[\text{Ir}(\text{COD})_2]^+\text{BF}_4^-$ Catalyzed Hydroformylation of Vinyltriethylsilane.^a

Entry	CO : H ₂ (psi)	Temp (°C)	% Linear	% Hydroformylation (GC yield) ^b	% Yield (isolated)	% Conv ^b	% Hydrogenation ^b	Ratio ^c HF ⁿ : H ₂ ⁿ
1	65 : 135	100	100	12	9	100	63	16 : 84
2	300 : 300	100	95	33	23	100	60	35 : 65
3	600 : 600	100	100	32	24	100	55	37 : 63
4	500 : 100	100	97	79	65	100	25	76 : 24
5	1000 : 100	100	100	20	-	37	4	86 : 14
6	700 : 100	100	97	80	60	83	15	84 : 16
7 ^d	350 : 50	100	99	33	-	36	6	84 : 16
8 ^d	700 : 100	140	90	80	60	99	11	87 : 13
9 ^e	700 : 100	60	97	36	-	70	4	90 : 10

^aReaction conditions: 3.2 mmol substrate, 0.058 mmol catalyst (1.8 %), 3 mL dry distilled benzene, 3 hours. ^bDetermined by GC vs. added internal standard (*m*-dimethoxybenzene). ^cHFⁿ = Hydroformylation, H₂ⁿ = Hydrogenation. ^d5 hours. ^e26 hours.

We attempted to decrease the partial pressure of CO (keeping the 7 : 1 ratio of CO : H₂ which we found to be most effective) by using 350 psi of CO and 50 psi H₂, but the conversion was only 33% after 5 hours (Table 10, entry 7). An increase or decrease in the reaction temperature had no effect, and therefore the best conditions remained 700 psi CO, 100 psi H₂, 100 °C, 3 hours and 1.8% catalyst, as shown in entry 6 of Table 10. It should be noted that with the exception of the isolated yields, all parameters listed in Table 10 were determined by GC versus an internal standard added after the reaction. Calibration curves were prepared for the starting material and products with the internal standard, but the yields are at best $\pm 5\%$ (see Experimental Section).

In analogy with the similarities observed with the rhodium zwitterionic and cationic complexes, we examined the zwitterionic iridium catalyst, [Ir(COD)]⁺BPh₄⁻, in the hydroformylation of vinyltriethylsilane under the now standard iridium conditions (700 psi CO, 100 psi H₂, 100 °C, 3h). Surprisingly, we observed almost no reaction after 3 hours, (8% yield by GC) and decided to test other iridium complexes.

We next studied the hydroformylation of vinyltriethylsilane with commercially available hydrated iridium trichloride, and found that it alone did not catalyze the reaction. However, the addition of 1.5–2.0 equivalents of silver salts such as AgBF₄ or AgPF₆ produced a species which did catalyze the hydroformylation after extended periods of time (Table 11, entries 3 and 4). It should be noted that these reactions are all run in a mixture of benzene and chloroform or dichloromethane. The chlorinated solvent was added in an attempt to increase the polarity of the medium and thus the solubility of the iridium and silver species. The aromatic solvent was added because the results we obtained with the rhodium systems initially indicated that the cationic complexes only catalyzed the hydroformylations in aromatic solvents. (The [Ir(COD)₂]⁺BPh₄⁻ reactions were run in benzene.) Although it was shown that at 700 psi of CO Rh⁺ catalyzed the hydroformylation of vinyltriethylsilane in non-aromatic solvents, this result was obtained after the IrCl₃ experiments.

Table 11: Iridium Trichloride Catalyzed Hydroformylation of Vinyltriethylsilane.^a



Entry	Time (h)	Solvent	% Linear	% Hydroformylation ^b (GC yield)	% Conv ^b	% Hydrogenation ^b	Additive	Preactivation (Temp/Time)
1	3	PhH/CH ₂ Cl ₂	NR ^c	-	-	-	-	-
2	3	PhH/CHCl ₃	NR	-	-	-	-	-
3	14	PhH/CHCl ₃	100	54	100	21	AgPF ₆	-
4	O/N ^d	PhH/CHCl ₃	100	50	66	10	AgBF ₄	-
5	3	PhH/CHCl ₃	NR	-	-	-	AgBF ₄	-
6	3	PhH/CHCl ₃	98	59	92	16	AgBF ₄	160 °C / 1.0 h
7	3.5	CHCl ₃	100	54	99	32	AgBF ₄	160 °C / 45 min
8	3	CHCl ₃	100	46	99	18	-	160 °C / 45 min
9	3	CHCl ₃	NR	-	-	-	-	-

^aReaction conditions: 3.2 mmol substrate, 0.058 mmol catalyst (1.8 %), 3 mL dry distilled solvent, 100°C, 700 psi CO, 100 psi H₂, 1.5-2 equivalents of additive. ^bDetermined by GC vs. added internal standard (*m*-dimethoxybenzene). ^cNR = no reaction. ^dO/N = overnight.

It was adventitiously discovered that pretreating the Ir/Ag mixture at 160 °C for 45–60 minutes in the presence of CO and H₂ substantially reduced the time required for the reaction (compare entries 4, 5 and 6). In fact, using this preactivation protocol, the reaction proceeded without the addition of silver salts (Table 11, entry 8). In analogy with our results obtained with the Rh⁺ systems at high CO pressures, the Ir⁺ catalyzed hydroformylation reactions proceeded just as effectively without any added benzene (Table 11, entries 7 and 8).

Regarding selectivity, with one exception (entry 6), in all of the hydroformylation reactions catalyzed by IrCl₃, with or without silver salts, *the linear isomer was the only aldehyde detected by GC analysis of the crude reaction mixtures*. One drawback to the IrCl₃ catalyzed hydroformylation reactions is the larger amount of hydrogenation observed compared to the [Ir(COD)₂]⁺BF₄⁻. Under the conditions examined in this study, 10–32% of the starting material is directly hydrogenated to tetraethylsilane. While the volatility of this substance ensures that it can be easily removed from the product, the yields of the aldehydes are lower than in most of the other systems examined.

After discovering the preactivation protocol described above for IrCl₃, we re-examined the zwitterionic complex, [Ir(COD)]⁺BPh₄⁻. These experiments are collected in Table 12 on the following page.

Table 12: Catalytic Activity of Ir²⁺ in the Hydroformylation of Vinyltriethylsilane After Preactivation at 160 °C.^a



Entry	Time (h)	% Catalyst	Temp (°C)	% Linear	% Hydroformylation ^b (GC yield)	% Conv ^b	% Hydrogenation ^b	Preactivation (Temp/Time)
1	3h	0.6	100	91	8	19	3	none
2	3h	0.6	100	91	87 (75) ^c	100	16	160 °C / 1h
3	3h	0.6	60	NR ^d	-	-	-	160 °C / 1h
4	3h	0.1	100	90	33	51	6	160 °C / 1h
5	9h	0.1	100	94	(73)	100	-	160 °C / 1h

^aReaction conditions: 3.2 mmol substrate, 0.019 mmol (0.6 %) catalyst, 3 mL dry distilled CHCl₃, 700 psi CO, 100 psi H₂. ^bDetermined by GC vs. added internal standard (*m*-dimethoxybenzene). ^cIsolated yields are given in brackets. ^dNR = no reaction.

After preactivation of Ir^{zw} at 160 °C for ca. 1 hour as previously described, 87% yield of the desired aldehyde was obtained. The selectivity for the linear isomer was high (91% of the total aldehyde) but not as high as that obtained in the IrCl₃ catalyzed hydroformylation reactions (99–100%). However, considerably less competing hydrogenation was observed in the Ir^{zw} reactions (16% at 100% conversion, Table 12, entry 2).

Since we observed 100% conversion after 3 hours at 100 °C (after preactivation at 160 °C), we repeated the hydroformylation at 60°C (entry 3) but observed no reaction. From the experiment shown in entry 4 of Table 12, we could calculate the turnover number to be approximately 180 per hour at 100 °C. Thus employing a substrate to catalyst ratio of 1000 : 1, we were able to affect complete conversion of the starting material after only 9 hours and isolated the aldehyde in 73% yield (entry 5).

Finally, it was found that the Ir^{zw} system was catalytically active for the hydroformylation of vinyltriethylsilane even without preactivation, but there was an inhibition period. This explains our first result with Ir^{zw} which led us to believe that this complex displayed poor catalytic activity. In fact, as can be seen from Table 13 and Figure 3, after three hours the hydroformylation had just begun. If the reaction is left for 5 hours, 82% of the hydroformylated product is observed by GC, (entry 3). (This is another example where the error in the GC measurements is obvious, i.e. the hydroformylation and hydrogenation products total more than 100%.) If the hydroformylation is run at 160 °C, complete conversion is observed after only 1.5 hours, and the aldehyde is obtained in 70% GC yield.

Table 13: Catalytic Activity of Ir^{ZW} in the Hydroformylation of Vinyltriethylsilane Without Preactivation.^a



Entry	Time (h)	% Catalyst	Temp (°C)	% Linear	% Hydroformylation ^b (GC yield)	% Conversion ^b	% Hydrogenation ^b
1	3	0.6	100	91	8	19	3
2	4	0.6	100	91	29	43	7
3	5	0.6	100	93	82	100	26
4	1.5	0.6	160	91	70	100	21

^aReaction conditions: 3.2 mmol substrate, 0.019 mmol (0.6 %) catalyst, 3 mL dry distilled CHCl₃, 700 psi CO, 100 psi H₂. ^bDetermined by GC vs added internal standard (*m*-dimethoxybenzene).

The reaction profile for the Ir^{ZW} catalyzed hydroformylation without preactivation is shown in Figure 3. It should be noted that the conversion and the yield of the aldehyde closely parallel one another, unlike the Rh^{ZW} and Rh^+ catalyzed hydroformylation reactions (see Figure 1). Furthermore, the percentage of the linear isomer remains constant within experimental error ($\pm 5\%$). For comparison's sake, the yield obtained after 3 hours using pretreated Ir^{ZW} (87%) is shown with a blackened circle.

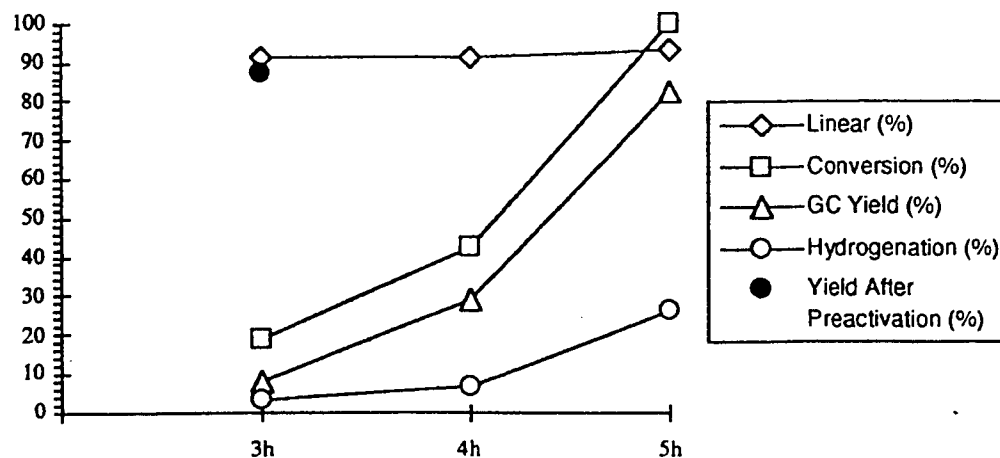

Figure 3: The Ir^{ZW} Catalyzed Hydroformylation of Vinyltriethylsilane Without Preactivation.

Pretreatment of Ir^{ZW} , although not necessary, dramatically increases the yield obtained after 3 hours. Since the Ir is already in the correct oxidation state, no reduction is required. The diene ligand should not be responsible for the inhibition period, since there was no discernible inhibition period in the hydroformylation reactions catalyzed by $[\text{Ir}(\text{COD})_2]^+\text{BF}_4^-$. Therefore, it is possible that the coordinated tetraphenylborate ligand must be displaced before reaction can begin. It is also possible that the limited solubility of Ir^{ZW} in the reaction solvent at $100\text{ }^\circ\text{C}$ is responsible for the induction period. When the reaction is run for only 3 hours, a large portion of the white iridium complex added at the beginning of the reaction remains undissolved. The rhodium analog, Rh^{ZW} , is also

virtually insoluble in benzene, but at the end of the reaction, a clear pale yellow solution is obtained. When a solution of Ir^{zw} is pretreated at 160 °C under CO and H₂, all of the white precipitate is gone and a pale yellow solution is obtained that contains a small amount of a bright yellow solid. IR and m.p. analysis indicated that this material was a mixture of [Ir₄(CO)₁₂] and [Ir(CO)₃]_n.⁸⁴ The poor catalytic activity displayed by [Ir₄(CO)₁₂] even after pretreatment and the proposed mechanism of the hydroformylation (which requires an Ir(I) hydride) suggest that this is not the catalyst, but a by-product of the conversion of Ir^{zw} to the catalytically active species.

The activity of other, commercially available, iridium complexes was examined in the hydroformylation of vinyltriethylsilane with and without preactivation. It was found that of those complexes examined, only the Ir(I) species, were active without preactivation. Thus [Ir(COD)₂]⁺BF₄⁻, Ir^{zw}, [Ir(COD)Cl] and [Ir(CO)₃Cl] were all effective catalysts for the hydroformylation reaction. As expected, all gave the linear isomer as the major product with greater than 90% selectivity, and the only side product observed was tetraethylsilane which was easily separated from the aldehyde product *in vacuo*. Vaska's complex, [IrCl(CO)(PPh₃)₂], was the only iridium complex that did not catalyze the hydroformylation of vinyltriethylsilane to any appreciable extent even after preactivation. The data obtained using the preactivation protocol are shown in Figure 4 for comparison's sake.

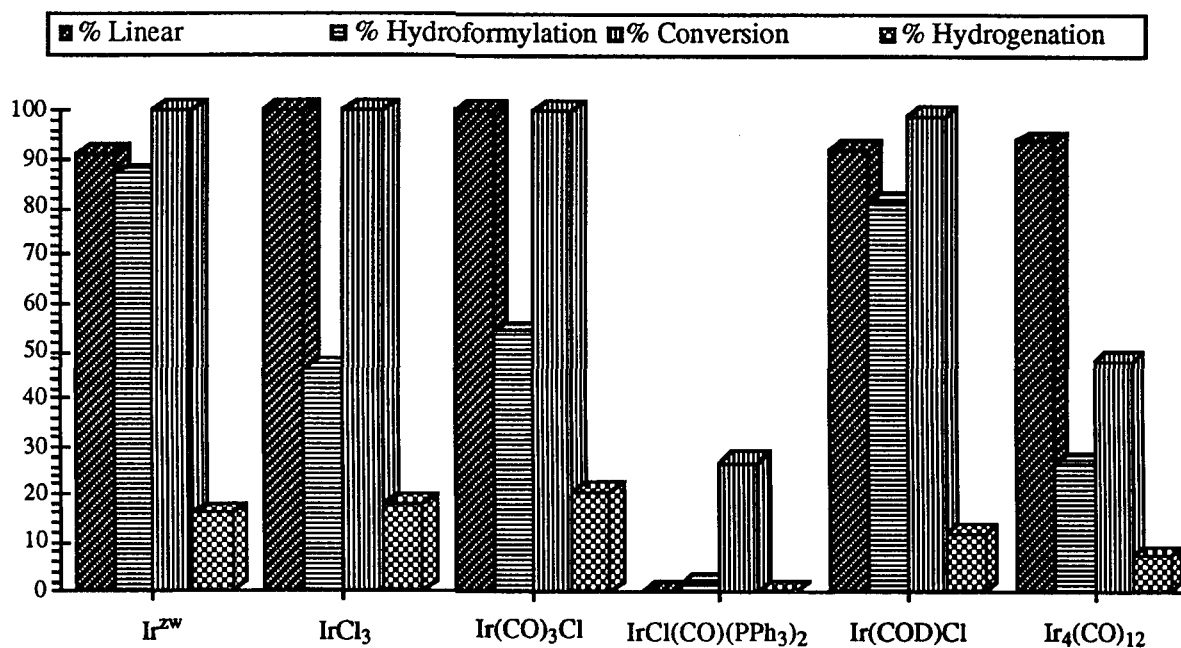

Figure 4: Iridium(III), (I) and (0) Complexes as Catalysts for the Hydroformylation of Vinyltriethylsilane After Preactivation

Next to Vaska's complex, the least reactive complex studied was the zero-valent $[\text{Ir}_4(\text{CO})_{12}]$. Even after pretreatment at 160 °C for 1 hour and reaction for 3 hours at 100 °C, the GC yield was only 27% (with 94% selectivity for the linear isomer). The most selective catalysts are $\text{Ir}(\text{CO})_3\text{Cl}$ and IrCl_3 , which yielded no detectable branched aldehyde (by GC). In terms of the total yield of aldehyde, Ir^{Zw} was the best (90% yield).

Finally, we examined the effect of PPh_3 on the Ir-catalyzed hydroformylation reactions. Unlike the rhodium systems where the addition of phosphine had a strongly activating effect (see Table 8), in the iridium systems the addition of as little as 1 equivalent of PPh_3 completely suppressed the reaction. This may explain the lack of reactivity of Vaska's complex in the hydroformylation of vinyltriethylsilane.

Based on what is known about the mechanism of the hydroformylation reaction¹¹⁻¹⁵, the active catalyst for the reaction is likely an Ir(I) hydride species. Presumably, the preactivation period required in the reactions with IrCl_3 is necessary in order to reduce the

Ir(III) to Ir(I) and generate a metal hydride. It is well known that induction periods are often observed when complexes containing chloride ligands are used as pre-catalysts for the hydroformylation reaction. For example, when $\text{RhCl}(\text{CO})(\text{PPh}_3)_2$ was used in the hydroformylation of 1-pentene, an induction period of 1.5 hours was observed.^{11a} When the closely related hydride, $\text{HRh}(\text{CO})(\text{PPh}_3)_3$, was used, there was no induction period. In this case, the addition of a base such as a tertiary amine to the reaction mixture substantially decreased the time required for the hydroformylation to begin.^{11a} However, the addition of triethylamine to the IrCl_3 reaction system did *not* remove the need for preactivation (there was no reaction after 3 hours when a 3 : 1 ratio of Et_3N and IrCl_3 was employed).

It is known that the exposure of IrCl_3 to carbon monoxide under elevated temperatures ($>150\text{ }^\circ\text{C}$) produces a mixture of iridium carbonyl chlorides as shown in equation 55.

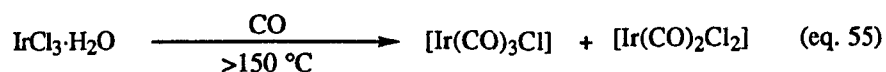

We therefore propose that the catalytic species obtained from the pretreatment of IrCl_3 under CO and H_2 is the same as that obtained from the reaction of $\text{Ir}(\text{CO})_3\text{Cl}$ with CO and H_2 . In fact, the reaction profile for these two systems is quite similar: IrCl_3 ; 46% yield, 18% hydrogenation, 100% linear, 100% conversion, $\text{Ir}(\text{CO})_3\text{Cl}$; 54% yield, 20% hydrogenation, 100% linear and 100% conversion.

Since the various Ir complexes studied in the hydroformylation of vinyltriethylsilane displayed considerably different reactivity, the exact nature of the active catalyst obtained by treatment with CO and H_2 at $160\text{ }^\circ\text{C}$ must be different. Based on what is known about the mechanism of the hydroformylation, a carbonyl hydride must be present at some point, but the ancillary ligands and/or the charge on the iridium obviously play an important role in determining the precise nature of the reaction. Furthermore, extrapolation of the results

obtained using Rh^{zw} or Rh^+ to the corresponding iridium systems is not necessarily valid, and the different influences of PPh_3 on the activity of the catalysts illustrates this point well.

2.2.3 Cobalt Catalyzed Hydroformylation Reactions

Unlike IrCl_3 , cobalt chloride (hydrated or anhydrous) did not catalyze the hydroformylation of vinyltriethylsilane after preactivation or upon the addition of silver salts. Although it was not possible to obtain the exact cobalt analogs of the cationic and zwitterionic rhodium and iridium complexes described thus far, the cationic cobalt cluster, $[\text{Co}_3(\eta^6\text{-C}_6\text{H}_6)_3(\mu_3\text{-CO})_2]\text{BPh}_4^-$, was found to be an effective catalyst for the hydroformylation of vinyltriethylsilane. This complex is cationic and each cobalt atom contains a η^6 -coordinated benzene.⁸⁵

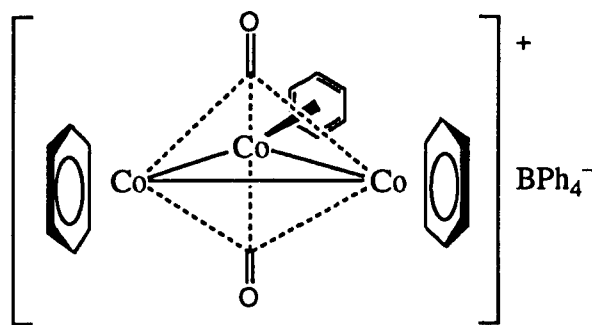
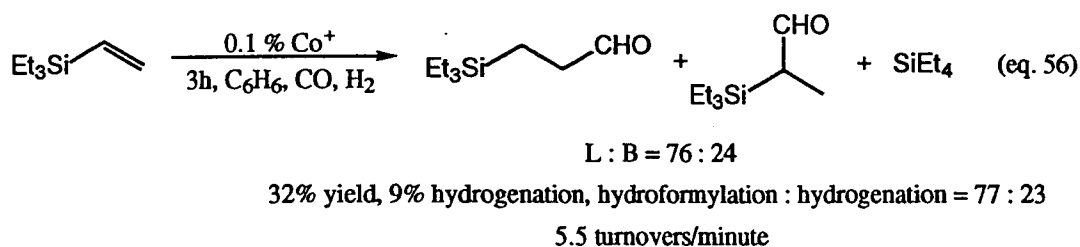

Figure 5: $[\text{Co}_3(\eta^6\text{-C}_6\text{H}_6)_3(\mu_3\text{-CO})_2]\text{BPh}_4^-$, (34).

In the presence of 0.1% of compound 34, vinyltriethylsilane was hydroformylated in 3 hours (330 turnovers per hour) yielding the linear isomer as the major product (B : L = 24 : 76). Unlike the rhodium catalyzed hydroformylation reactions, the crude reaction mixture contained some hydrogenated starting material ($\text{Hf}^n : \text{H}_2^n = 77 : 23$).



2.3 Conclusions

Of the rhodium complexes examined thus far, Rh^{ZW} is the only one capable of producing the branched aldehyde in excess over the linear in the hydroformylation of vinyltrimethylsilane. Furthermore, although the isolated yields are low, our method stands out among the very few reported routes to α -silylaldehydes.

It has been demonstrated that a variety of commercially available iridium complexes are effective catalysts for the hydroformylation of vinyltriethylsilane, some producing >99.5% selectivity for the linear isomer without the addition of any phosphines. This is a convenient alternative to the existing hydroformylation methodology which requires the addition of a vast excess of tertiary phosphine. It also contrasts nicely with the rhodium systems which produce the branched aldehyde selectively in the hydroformylation of vinyltrimethylsilane.

The cationic cobalt cluster shown in Figure 5 was more active than any of the other complexes examined, completing 1,000 turnovers in 3 hours (>5 turnovers per minute). The linear aldehyde was the major product, but the selectivity was inferior to the iridium catalyzed hydroformylation reactions.

The iridium and rhodium complexes examined had completely different responses to the addition of triphenylphosphine. The addition of only *two equivalents* of triphenylphosphine had a dramatic effect on the regioselectivity of the Rh^{ZW} and Rh^+

catalyzed hydroformylation of vinyltriethylsilane giving almost exclusively the linear isomer (B:L = 7:93). Under these conditions, the isolated yield was consistently greater than 90% after as little time as 0.5 hours. On the other hand, the addition of only one equivalent of triphenylphosphine to a solution of preactivated Ir^{zw} completely inhibited the hydroformylation of vinyltriethylsilane.

We have shown that by employing either the rhodium or iridium zwitterionic catalysts, it is possible to obtain selectively the branched or linear silyl aldehydes by the hydroformylation of commercially available vinyltrialkylsilanes. The linear aldehyde can also be obtained selectively in the iridium systems or in the rhodium systems if two equivalents of triphenylphosphine are added or if the P_{CO} is increased. The hydroformylation reactions described represent a one step preparation of synthetically useful α - and β -silyl aldehydes.

Chapter Three: Attempts to Prepare a New Catalyst for Asymmetric Hydroformylation

3.1 Introduction

3.1.1 Asymmetric Catalysis

Catalysis by transition metals modified with chiral ligands provides an attractive alternative to more conventional approaches such as those employing chiral auxiliaries. The reason for this is obvious. If the transition metal is used in catalytic quantities, catalytic amounts of the chiral ligand are also required, as opposed to *traditional* techniques employing stoichiometric amounts of a chiral auxiliary or reagent. By far the most successful examples of catalytic asymmetric systems involve oxidation and reduction reactions.

Elegant work on the transition metal catalyzed reduction of functionally substituted olefins and carbonyl containing compounds has been described by Noyori and co-workers.⁸⁶ Using the axially dissymmetric compound 1, 1'-bis (diphenylphosphino) binaphthyl (BINAP) (**34**) as a bidentate ligand for Rh, Noyori was able to achieve unrivaled enantioselectivities for the dihydrogen mediated reduction of acrylate esters.⁸⁶ These substrates are important because their reduction products are protected amino acids. BINAP is also an extremely useful ligand for ruthenium in the reduction of prochiral ketones.

Hayashi recently synthesized a series of *monodentate* chiral ligands (**35**) that closely resemble BINAP. His development of this class of ligands represents a significant departure from a trend in asymmetric reductions toward the use of bidentate, C₂-symmetrical ligands. The use of ligand **35** enabled Hayashi to effect the catalytic asymmetric hydrosilation of simple olefins in greater than 95% ee.⁸⁷ The utility of this

method lies in the known oxidation of the resulting carbon silicon bond to an alcohol which occurs with retention of stereochemistry.⁸⁸

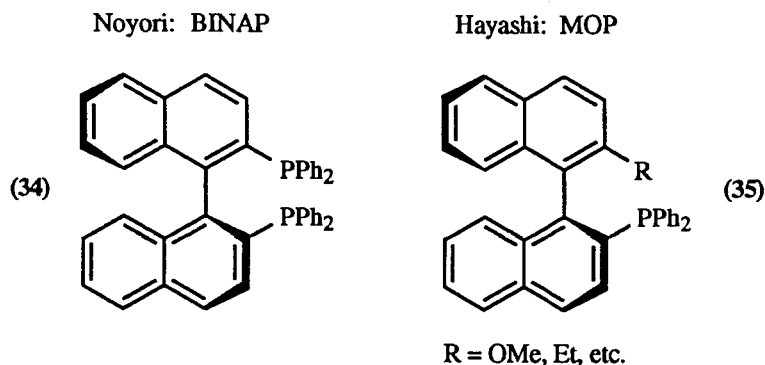

Figure 6: Binap and MOP: Effective Axially Dissymmetric Ligands.

In the area of asymmetric oxidations, Sharpless has led the field by developing both the asymmetric epoxidation (AE) of allylic alcohols, and the asymmetric dihydroxylation (AD) of olefins.⁸⁹ Finally, Jacobsen recently described a manganese-salen system capable of effecting the enantioselective epoxidation of unsubstituted olefins. This is extremely important since it permits the epoxidation of olefins other than allylic alcohols with excellent enantioselectivities.⁹⁰

With a few notable exceptions including the palladium catalyzed Grignard cross coupling and allylic coupling reactions developed by Hayashi,⁹¹ catalytic asymmetric carbon-carbon bond forming reactions have not been as successful as enantioselective oxidation and reduction processes. The same, until recently, was true of carbonylation reactions.

Of the two types of carbonylation reactions outlined in the introduction of this thesis, (addition and insertion/substitution reactions), the majority of the research into chiral induction has focused on addition reactions. Two examples of enantioselectivity in insertion/substitution reactions are shown below, which are both kinetic resolutions. The first was reported in 1988, by Petrigani et al.⁹² They described the palladium catalyzed

carbonylation of 1-phenylethylbromide yielding 2-phenylpropionic acid as shown in equation 57.

In this study, a moderate difference in the rates of the carbonylation of the two enantiomers was observed, which was shown to be dependent on the metal to ligand ratio. At a ratio of 4, the relative rate is 2.4 which represents a potential ee of 40%, and when 6 equivalents of the ligand were used per metal atom, the relative rate was found to be 5.1 (67% ee).

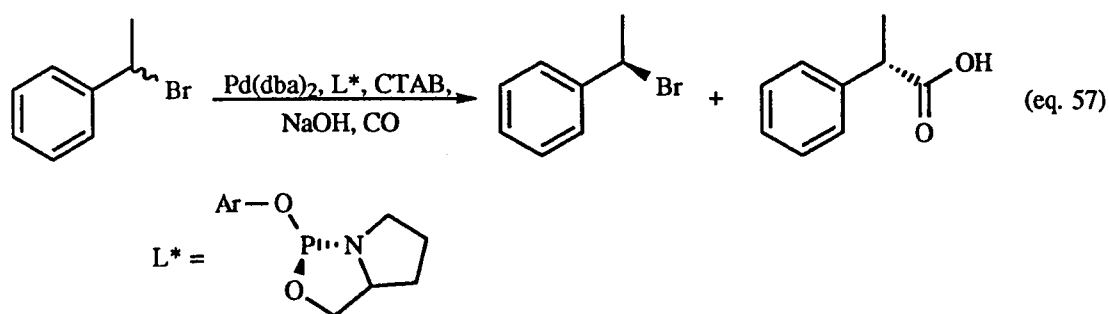

Much better results were obtained in the rhodium catalyzed carbonylative insertion of aziridines.⁵¹ In fact, Consiglio recently described this reaction as: "The only [enantiomer discriminating] system that has given excellent results to date..."⁹³ Using menthol as the ligand, Alper, Calet and Urso were able to effect the carbonylation of 1-*t*-butyl-2-phenyl aziridine in 99.5% ee (equation 58).⁵¹

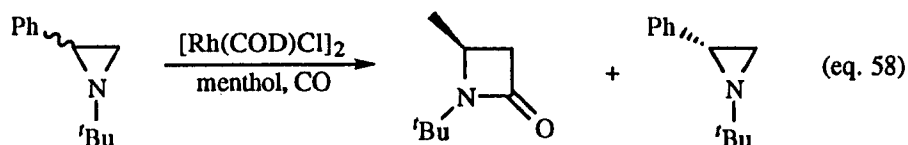

Most of the research efforts in asymmetric carbonylations have centered around addition reactions, specifically hydroformylation. Until recently, only platinum catalysts have been successful, but in 1993 Takaya et al. reported a highly efficient rhodium

catalyzed enantioselective hydroformylation. These results and others will be described in the next section.

3.1.2 Asymmetric Hydroformylation

The development of a successful and general asymmetric hydroformylation catalyst is hampered by the poor regiochemistry observed in many systems (see Chapter 1, equation 1). For two types of substrates regioselectivity is not an issue, namely vinylidene olefins and symmetrical olefins. The hydroformylation of vinylidene olefins gives only the linear product except in a few rare cases, and so the enantioselectivity is determined by the placement of the hydride, not the formyl group. Unfortunately, the enantioselectivities reported for the rhodium catalyzed hydroformylation of this type of substrate have been poor to low (22% ee for the hydroformylation of 2, 3-dimethyl-1-butene using CHIRAPHOS)^{94a} and platinum catalysts have given only slightly better results (46% ee).^{94b,c} Higher ee's have been reported in the hydroformylation of methylmethacrylate using [(-)-BPPM]PtCl₂ (36) and SnCl₂. If the reaction is run to low conversion (36%) and an excess of H₂ is used in the gas mixture, 60% ee can be obtained (see equation 59).⁹⁵

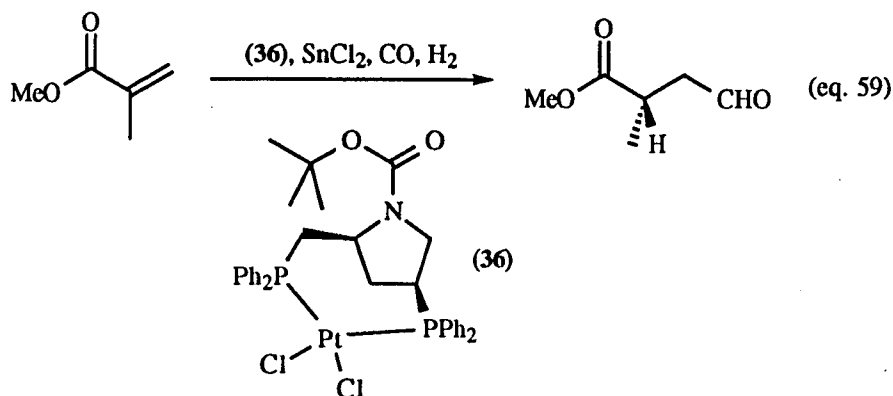

The hydroformylation of symmetrical olefins is practically the only way to obtain reasonable amounts of the branched isomer in the hydroformylation of aliphatic olefins. This is because more than 50 years after the discovery of the hydroformylation reaction, there is no known system which produces more than 50% of the branched isomer in the hydroformylation of simple aliphatic olefins.^{93b} With rhodium systems, until this year, the best ee obtained for the hydroformylation of (Z)- or (E)-2-butene was ca. 19%.⁹⁶ Platinum systems gave better results (30% ee) when modified by SnCl₂ with [bicyclo[2.2.2]octane-3,4-diylbis(methylene)]bis(5*H*-benzo[*b*]phosphindole) (37) as the chiral ligand.⁹⁷ In 1994, Takaya et al. reported the use of their BINAP based phosphine-phosphite system (called BINAPHOS, compound 38) in the hydroformylation of (E)- and (Z)-2-butenes. With this system, they obtained excellent ee's (82% for (Z)-2-butene), surpassing by far anything obtained in hydroformylation reactions using rhodium or palladium catalysts.⁹⁸

Scheme 15: Asymmetric Hydroformylation of 2-Butene

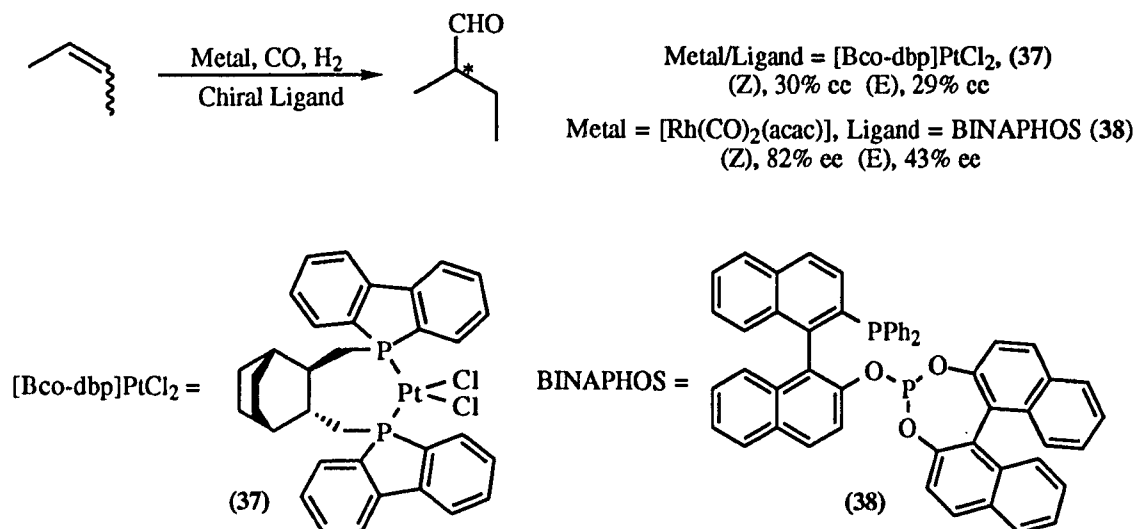

For the hydroformylation of terminal olefins, only the branched isomer contains a stereogenic center, and, as previously noted, the best systems produce at most 50% of this isomer in the aliphatic series. Catalytic systems with sterically demanding ligands often give even less of the branched isomer. Platinum/tin systems give good enantiomeric excesses for the hydroformylation of 1-butene (67%)⁹⁹ after 4 hours at 34% conversion with 14% of competitive hydrogenation and a B : L ratio of 14 : 86.⁹⁷ Synthetically speaking, the utility of this method is severely limited due to the low conversion and low B : L ratio. Until the 1993 and 1994 reports by Takaya et al., the best enantiomeric excess reported in the rhodium catalyzed hydroformylation of simple terminal olefins was 20% with 1-pentene as the substrate and DIOP as the ligand.¹⁰⁰ The branched isomer, however, was only 10% of the total aldehyde produced. Takaya's BINAPHOS-Rh system hydroformylates 1-hexene with an unprecedented 75% ee.⁹⁸ Although the branched isomer was the minor product of the reaction, the 24 : 76 B : L ratio is also better than that reported by Consiglio et al. (B : L = 14 : 86).¹⁰⁰

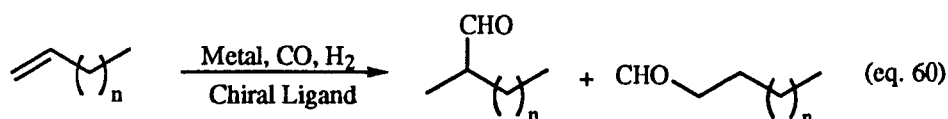

Metal/Ligand = [Bco-dbp]PtCl₂, SnCl₂ (37) n = 1,

B : L = 14 : 86, 67% ee, 34% conversion

Metal = [Rh(CO)₂(acac)], Ligand = BINAPHOS (38) n = 3,

B : L = 25 : 75, 75% ee

Functionalized terminal olefins such as styrene and its derivatives are promising substrates for the hydroformylation reaction for several reasons. Unlike aliphatic substrates, the branched isomer is usually the major isomer, and the regioselectivity can be quite good. Isomerization of the alkene is obviously not a problem for styrene, and finally, the product aldehydes can be easily oxidized to 2-arylpropionic acids which have potent biological activity.¹⁷ Although hydrocarboxylation would be a more direct route

to these compounds, until recently the severe conditions required for this reaction (high temperatures and pressures) discouraged research into asymmetric induction. As mentioned in the introduction, Alper et al. have developed a variety of systems for the hydrocarboxylation of olefins under extremely mild conditions, and have studied these reactions in the presence of chiral ligands.³¹ With the exception of this work, most studies have been confined to asymmetric hydroformylations.

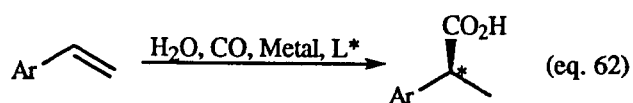
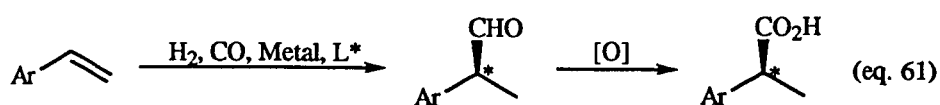

Ar = 8-methoxynaphthyl, Naproxen

Ar = 4-iso-butylphenyl, Ibuprofen

Before Takaya's report, platinum catalysts had been much more promising than rhodium catalysts for the asymmetric hydroformylation of styrene derivatives. Typically, 20–30% ee was observed in the rhodium catalyzed hydroformylation of styrene while Consiglio's dibenzophosphole/PtCl₂/SnCl₂ system gave excellent results with the same substrate (86% ee, 98% conversion and B : L = 80 : 20).¹⁰⁰ Stille reported a system which hydroformylated styrene with a similar enantiomeric excess (74%) and branched to linear ratio (76 : 24) but the reaction was run to only 20% conversion.¹⁰² Interestingly, the ligand that Stille found to be most effective was also modified by replacing diphenylphosphines with dibenzophospholes (see compound 39 in equation 63). Since it was observed that racemization of the product aldehydes was taking place, the reaction was run in the presence of 2–4 equivalents of triethylorthoformate in order to trap the aldehydes as their acetals. This caused a considerable decrease in the rate of the reactions, which were run for ca. 100 hours. Under the best conditions, styrene was

hydroformylated after 95 hours in >96% ee as a 78 : 22 mixture of branched and linear isomers (conversion = 56%).¹⁰¹

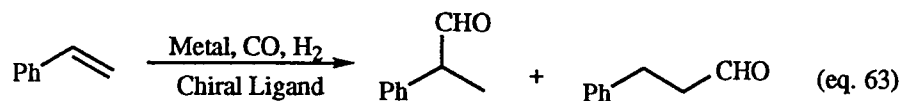

Metal/Ligand = complex (39)

B : L = 78 : 22, >96% ee, 56% conversion, 95 hours

Metal/Ligand = [Bco-dbp]PtCl₂ (37), SnCl₂

B : L = 14 : 86, 67% ee, 34% conversion

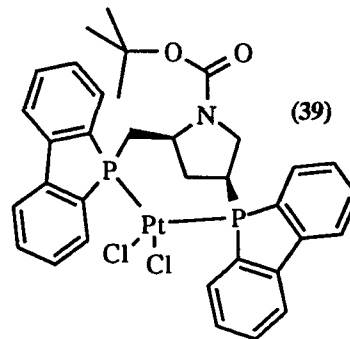

Although these studies represented considerable advances in asymmetric hydroformylation, Takaya's 1993 results with BINAPHOS¹⁰² are the best known to date. He found that using 0.05% of Rh(acac)(CO)₂ and 0.1–0.2% of BINAPHOS (38), styrene could be hydroformylated in >99% conversion after 43 hours at 60 °C. The branched aldehyde was 88% of the total aldehyde and was obtained in a remarkable 94% ee.¹⁰²

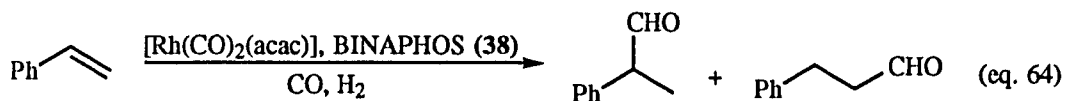

B : L = 88 : 22, conversion >99%, 43 h,
94% ee

3.2 Results and Discussion

At the conception of this work, the highly successful system discovered by Takaya et al.^{97, 102} had not been described, and thus the highest report ee for the rhodium catalyzed hydroformylation of styrene was 30%. Chiral ligands other than phosphines have been examined without much success, including β -diketonates, substituted cyclopentadienes and phosphites. This fact, and our interest in determining the nature of the catalytic species in the Rh^{zw} catalyzed hydroformylation reactions described in Chapter 2 prompted us to begin a study of the use of chiral arenes as ligands for cationic rhodium complexes.¹⁰³

3.2.1 Stability of Rh^{zw} Under the Reaction Conditions

Before beginning a synthesis of the chiral arenes and their complexes with rhodium, it was important to determine whether or not the BPh_4^- counterion indeed remained co-ordinated to the rhodium during the reaction. Our results in the vinylsilane systems *implied* that arene co-ordination was important for activity in the cationic rhodium system (Rh^+) and the similarity of these systems with Rh^{zw} suggests that arene coordination occurs in both systems (see Chapter 2). However, the applications of these results to other systems must be done with care since vinylsilanes are bulky olefins, which bind weakly to metal centres.¹⁰⁴

Our studies began with an examination of the rhodium complex (Rh^{zw}) under the reaction conditions. The first step in generating the active catalyst is most likely removal of the diene by hydroformylation to cyclooctene carboxaldehyde.¹⁰⁵ This generates the co-ordinative unsaturation required for binding of the substrate, the CO and H_2 . We hoped to detect a rhodium complex in which one of the arenes of BPh_4^- was still

coordinated, but the COD had been replaced by one or more of the reactive species, for example CO, hydride or the alkene. The binding of the arene to the rhodium can be easily seen by NMR since the protons of the co-ordinated arene resonate 0.7–1 ppm upfield of the uncomplexed aromatic protons.^{18,19} Thus the Rh^{zw} catalyzed hydroformylation of vinyltriethylsilane was performed in a thick walled NMR tube specifically designed for high pressure spectroscopy.¹⁰⁶ Unfortunately, the low maximum pressure (100 psi) combined with the small volume of the tube meant that the decomposition of the catalyst to rhodium metal occurred at temperatures >70 °C. Therefore, the experiments were performed in stainless steel autoclaves as previously described, using glove bag techniques to transfer the solutions for NMR analysis. The results of this study are shown below.

The hydroformylation reaction was run at 100 °C in CDCl₃ (which was pretreated by passing it through a small column of alumina) using 15% Rh^{zw} and 200 psi of a 1 : 2 mixture of CO : H₂. After one hour, the autoclave was cooled and transferred to a glove bag where it was disassembled and 0.5 mL withdrawn for NMR analysis. (The NMR tube was flushed with dry nitrogen before it was put in the glove bag.) The crude ¹H NMR showed that as expected, the diene had been hydroformylated¹⁰⁵, but we observed no signals upfield of the simple phenyl substituents that would suggest the presence of a co-ordinated arene. However, the position of these signals is known to be highly dependent on the nature of the ancillary ligands. Replacement of the dienes with other ligands such as carbon monoxide might cause the signals of the protons on the co-ordinated arene to move downfield, thus obscuring them under the protons from the simple phenyl substituents.

We were surprised to observe a strong signal in the aldehyde region at 10.0 ppm. Analysis of the ¹³C NMR spectrum confirmed that benzaldehyde had been produced in the reaction (equation 65). Since BPh₄⁻ was the only possible source of the

benzaldehyde, oxidative addition of one of the four B-Ph bonds¹⁰⁷ must have occurred, followed by carbonylation of the resulting metal σ -phenyl bond.

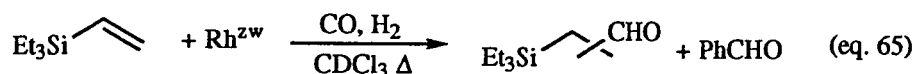

Since a large amount of the catalyst had been used and the conversion was 100%, it was possible that the catalyst decomposed after the olefinic substrate was used up. To test this possibility, a second reaction was run using a large amount of vinylsilane, and the reaction was stopped after 30 minutes in order to examine the decomposition at low conversion. ¹H NMR analysis of this reaction mixture indicated that decomposition to yield benzaldehyde occurred even in the presence of unreacted starting material.¹⁰⁸

The zwitterionic complex was then exposed to the reaction conditions in the absence of any vinylsilane and the exact amount of the decomposition measured by the addition of diisobutyl ether as an internal standard. Thus, after 3.5 hours at 75 °C under 200 psi of syn gas (CO : H₂ = 1 : 2), only 14% of the starting complex had degraded to benzaldehyde. Trace amounts of cyclooctenecarboxaldehyde and also some signals at δ 6.8–7.0 and 7.7–8.3 ppm due to BPh₃ and its decomposition products were also observed (see Figure 7).

In this experiment, vinyltriethylsilane was added to the autoclave after an aliquot had been removed for ¹H NMR analysis in order to see if the catalyst was still active. The system was repressurized with CO and H₂ and after three hours at 100 °C, the hydroformylation of vinyltriethylsilane was complete.

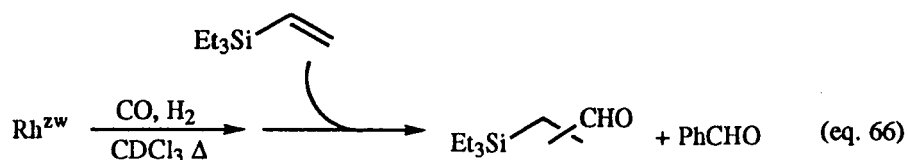

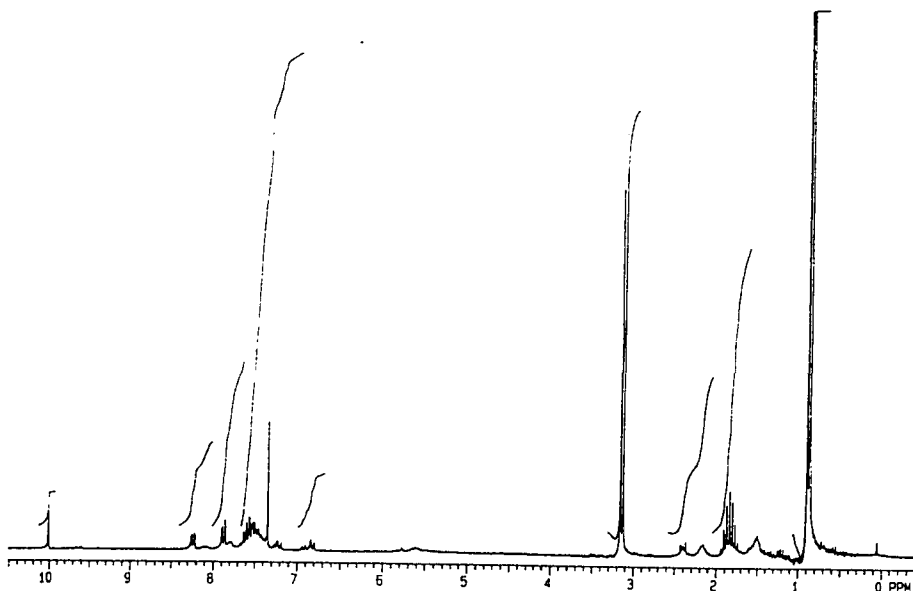

Figure 7: Decomposition of Rh^{zw} Under CO and H_2 at $75^\circ C$

Since the reaction mixture contained the rhodium species formed by decomposition of the BPh_4^- counterion along with remaining Rh^{zw} , it was impossible to tell what effect the decomposition of the counterion had on the ability of Rh^{zw} to catalyze the hydroformylation of vinyltriethylsilane. Much more information could be obtained if the complete decomposition of the counterion could be effected and the catalytic activity of the resulting mixture analyzed.

However, much to our surprise, even heating the zwitterionic complex in $CDCl_3$ to $140^\circ C$ for 16 hours under 450 psi of syn gas ($CO : H_2 = 1 : 2$), did not affect complete decomposition, at least via the benzaldehyde pathway. Under these conditions, 21% of the starting complex decomposed yielding benzaldehyde. A new signal at 4.6 ppm appeared in this spectrum due to benzyl alcohol formed by reduction of benzaldehyde (8%, see Figure 8 on the following page). Approximately 5–10% of the complex was also lost to benzene, although the aromatic region of the 1H NMR was too crowded to make a more exact measurement. The benzene may be produced under these more severe conditions (higher temperature and higher P_{H_2}) by reduction of the Rh–Ph bond instead

of carbonylation. Thus approximately 40% of the zwitterionic complex added to the reaction mixture had decomposed by oxidative addition of one of the B-Ph bonds. Vinyltriethylsilane added to the reaction mixture after this exhaustive treatment was hydroformylated to 100% conversion after 3 hours at 100 °C.

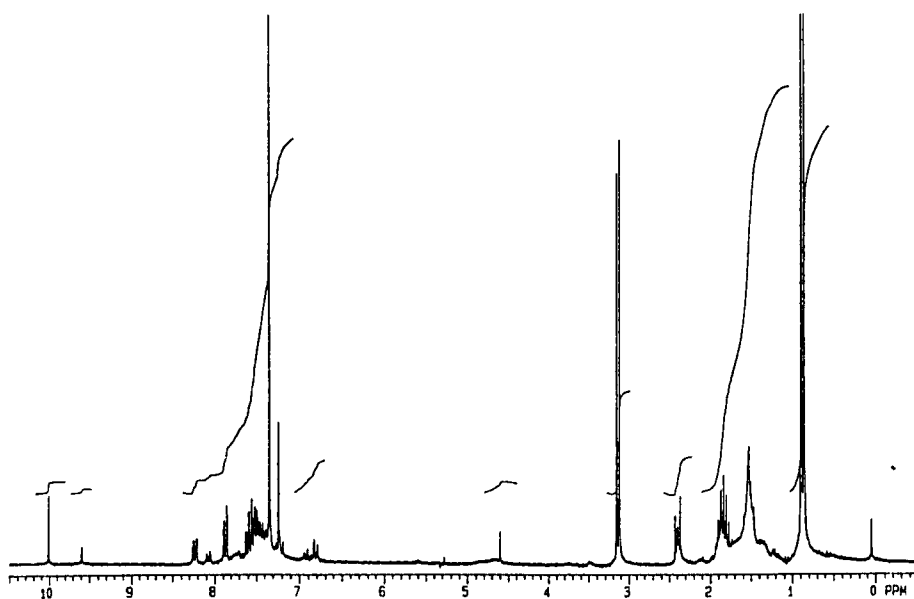
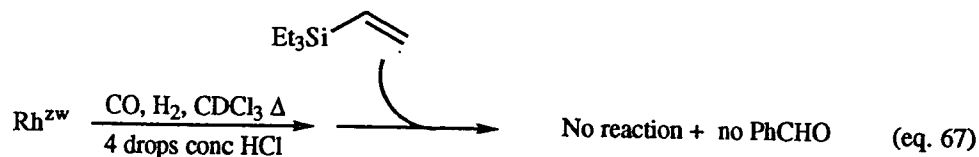

Figure 8: Decomposition of Rh^{ZW} Under 500 psi of CO and H_2 at $140^\circ C$

All attempts to affect the complete conversion of Rh^{ZW} to PhCHO or PhH and BPh_3 did not give more than 40% decomposition, and the resulting mixture was catalytically active for the hydroformylation of vinyltriethylsilane. Even the use of untreated $CDCl_3$ as the reaction solvent or the addition of 2 drops of water to the system did not increase the decomposition.

Finally, the addition of 4 drops of concentrated HCl to the reaction mixture prior to the addition of CO and H_2 did affect the complete decomposition of Rh^{ZW} , but by a different pathway since benzaldehyde was not detected. Vinyltriethylsilane added to this reaction mixture was not hydroformylated (equation 67).



Since we were unable to completely decompose the zwitterionic complex, we could not assess the catalytic activity of the rhodium species that resulted from decomposition of the co-ordinated BPh_4^- .

It was therefore decided that the most reliable method to prove that the arene (or BPh_4^-) was bound to the metal during the reaction was to prepare a chiral analog and examine the aldehyde produced for chiral induction. Any enantioenrichment in the product would provide strong evidence that the arene possessing the chiral group was bound to the metal during the alkene complexation which was shown by Consiglio to be the enantiodetermining step "in all but a few rare cases".¹⁰⁹ Previous attempts to modify the BPh_4^- counterion by replacing one of the phenyl rings with a chiral auxiliary such as α -pinene were unsuccessful.¹¹⁰ We therefore concentrated on the preparation of chiral arene rhodium complexes. When this research began, an effective system had not been developed for the rhodium catalyzed hydroformylation of alkenes. Thus it was also hoped that suitably functionalized arenes could be more effective than the ligands described in the literature.

3.2.2 Preparation and Testing of a Chiral Non-Racemic Arene as a Ligand for the Rh Catalyzed Hydroformylation of Alkenes.

A simple achiral arene-rhodium complex was first prepared by refluxing a solution of $[\text{Rh}(\text{COD})_2]^+\text{BF}_4^-$ and toluene in dichloromethane. After 16 hours, the reaction mixture was cooled and ether was added to precipitate the complex. The

precipitate was filtered and rinsed with ether yielding a dark yellow powder. An ^1H NMR analysis of this material showed that complexation of toluene had occurred, but only to 50% conversion. After an additional 24 hours refluxing in dichloromethane in the presence of toluene, 80% of the material isolated contained the desired η^6 -toluene complex (Rh^{tol} , **40**) shown below.

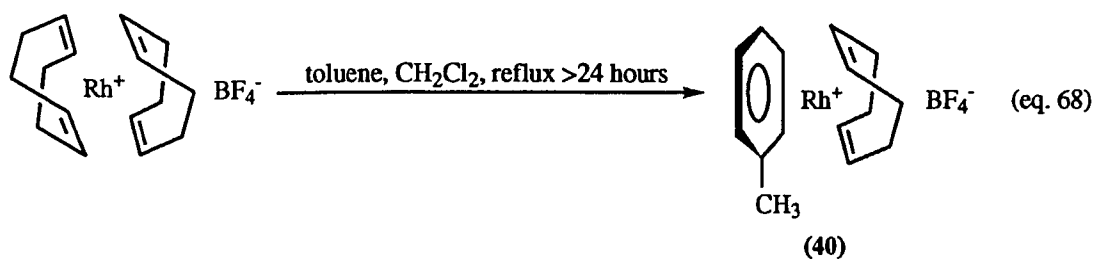

The most distinctive feature of the ^1H NMR spectrum of the toluene complex (**40**), Rh^{tol} , is the upfield shift of the signals from protons attached to the coordinated ring which resonate at 6.9–6.7 ppm. The rest of the spectral data match those reported by Green et al.¹¹¹

Rh^{tol} was found to catalyze the hydroformylation of vinyltriethylsilane in ether and in dichloromethane (see entries 3 and 7) which supports the claim that arene complexation is important for catalytic activity of Rh^+ or Rh^{ZW} in the hydroformylation of vinyltrialkylsilanes. The results shown in entries 2 and 3 (diethyl ether) and 6 and 7 (halocarbon) demonstrate that Rh^{tol} is an effective catalyst under conditions where Rh^+ is not.

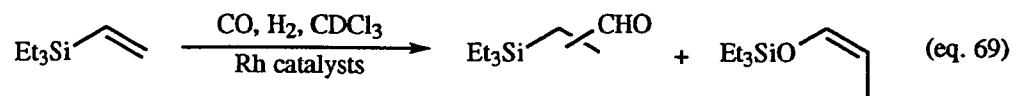
Table 14: Hydroformylation of Vinyltriethylsilane with Various Rhodium Catalysts^a

Entry	Catalyst	Solvent	Time (h)	Hydroformylation	Conversion	B : L ^b
1	Rh ^{zw}	Et ₂ O	1.5	27	32	30 : 70
2	Rh ⁺	Et ₂ O	3	NR	—	—
3	Rh ^{tol}	Et ₂ O	3	40	89	37 : 63
4	Rh ^{zw}	CH ₂ Cl ₂	1.5	33	74	23 : 77
5	Rh ^{zw}	CHCl ₃	1.5	38	95	5 : 95
6	Rh ⁺	CHCl ₃	3	NR	—	—
7	Rh ^{tol}	CH ₂ Cl ₂	3	25	72	9 : 91
8	Rh ⁺	toluene	1.5	31	78	29 : 71

^aReaction conditions: 3.2 mmoles substrate, 3 mL dry distilled solvent, 0.019 mmol catalyst (0.6%), 65 psi CO, 135 psi H₂, 100°C. ^bB : L = Branched : Linear.

The dramatic difference in reactivity observed between the arene complex and the simple diene rhodium complex is important for the proposed use of chiral arene rhodium complexes as asymmetric hydroformylation catalysts. As noted in the introduction, the principle of ligand enhanced catalysis is essential for successful catalytic asymmetric synthesis because catalytic systems are prone to dissociative equilibria. This is especially true of carbonylation reactions in which high pressures (i.e. high concentrations) of carbon monoxide are often used. In order to achieve asymmetric induction in these systems, *the metal–ligand complex must be a more active catalyst than other metal complexes resulting from dissociation of the chiral ligand (i.e. metal carbonyls).*

Having established that the toluene complex catalyzed the hydroformylation of vinyltriethylsilane in aromatic and non-aromatic solvents, we were then ready to prepare some chiral arene complexes and test them as hydroformylation catalysts. The substrate which we decided to focus on was styrene since it gave more than 95% of the branched isomer in reactions catalyzed by Rh^{zw} ,¹⁸ and there is a great deal of interest in its asymmetric synthesis in view of the biological activity of the closely related 2-arylpropionic acids, see Chart 1.¹⁷

Our previous studies (see Tables 7, 8 and 14) showed that only arene and BPh_4^- complexes catalyzed the hydroformylation of vinylsilanes in non-aromatic solvents, while Rh^+ did not. This is, therefore, a good example of ligand enhanced catalysis, but since vinylsilanes are very special substrates, we tested both Rh^{tol} and Rh^+ in the hydroformylation of styrene. In fact, both complexes catalyzed the reaction. Under these conditions, 100% conversion was achieved, and ^1H NMR analysis indicated that the branched to linear ratio was, as expected, >95 : 5 (equations 70 and 71).

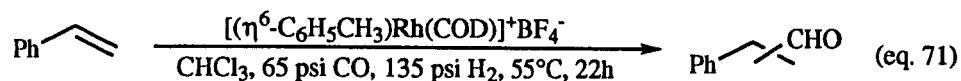
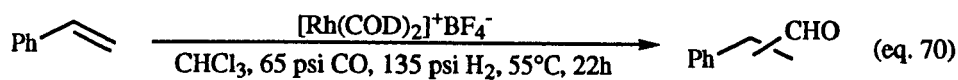

It was initially believed that complexation of the phenyl ring of styrene was responsible for the catalytic activity in the Rh^+ system described in equation 70. (Since only 1% of the catalyst was used the styrene : Rh^+ ratio was 99 : 1.) The following experiments demonstrated that this was not the case, since both Rh^{zw} and Rh^+ catalyzed the hydroformylation of terminal aliphatic olefins, in non-aromatic solvents.¹¹² Using 1-hexene, 1-octene and 1-decene, both catalysts gave a mixture of branched and linear isomers and catalyzed the isomerization of the starting material.

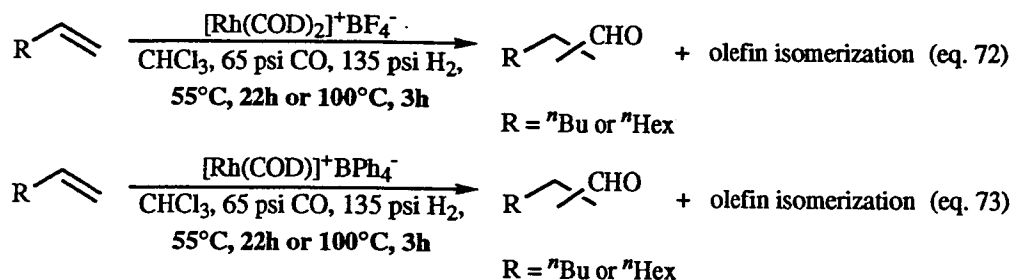

Based on the experiments shown in equations 72 and 73, it is likely that the olefin itself is able to complex Rh^+ and stabilize it enough for the hydroformylation to proceed. Vinylsilanes, being reasonably bulky, do not complex the rhodium as well as simple aliphatic olefins¹⁰⁴ and thus the low-ligated rhodium decomposes in the absence of another stabilizing unit such as the aromatic solvent or PPh_3 .^{82e, f} In order to test this hypothesis, both Rh^{zw} and Rh^+ were pretreated in CHCl_3 at 100°C under CO and H_2 in an attempt to decompose the cationic catalyst. After 3 hours, the autoclaves were cooled and the excess gas released. 1-Decene was added and then the autoclaves repressurized and left stirring at 55°C for 24h. Under these conditions, Rh^{zw} was an effective catalyst for the hydroformylation reaction and Rh^+ was not (see equations 74 and 75)!

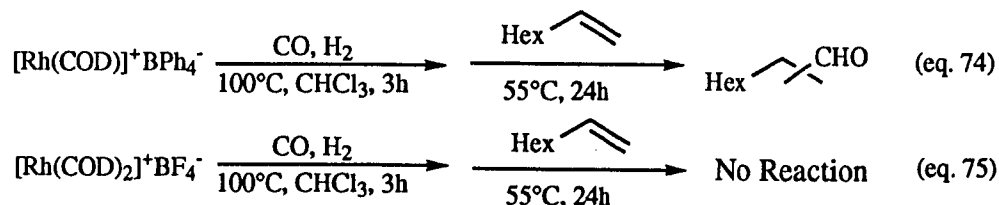

Thus, conditions had been developed under which catalytic activity was observed only with arene complexes. Having found these conditions, a study of the hydroformylation with the chiral arene complex was initiated. The arene examined first was 1-phenylethanol. Although the chiral center is remote from the reaction site, the commercial availability of the enantiopure alcohol made it our first choice. A

heteroatom containing side chain was chosen in the hope that chelation to the rhodium would minimize rotation about the C–Ph bond. The alcohol was protected as its *t*-butyldimethylsilyl ether since molecular models indicated that a bulky substituent would be most effective for enantioselectivity.

We began with a racemic arene, and attempted to prepare the arene–rhodium complex by adding the arene to the reaction mixture prior to pretreatment as shown below. In this way it was hoped that the arene complex would be prepared *in situ* and any remaining Rh⁺ would be decomposed. One equivalent of the arene was added and the mixture heated to 100°C under CO and H₂ for three hours before adding the alkene as previously described. Under these conditions, there was no reaction. The reaction was repeated with 5 equivalents of the racemic TBDMS protected 1-phenylethanol, but again the reaction failed. The same reaction was performed with 5 equivalents of toluene as a control in case the arene–silyl ether was too bulky and prevented complex formation. This reaction also failed.

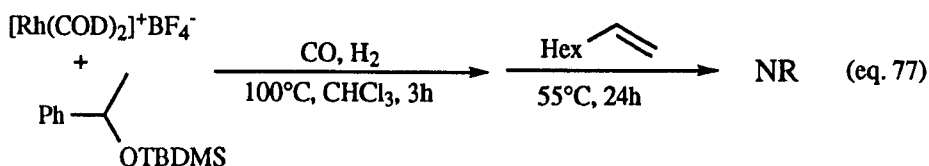
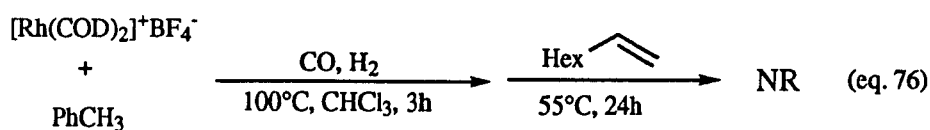

It has been previously shown¹¹¹ that the formation of arene complexes from cationic rhodium–diene complexes is easier when the diene is norbornadiene (NBD). For example, to make the toluene complex, $[\text{Rh}(\text{diene})\eta^6\text{-MeC}_6\text{H}_5]^+\text{BF}_4^-$, from the corresponding bis–COD complex, refluxing for >24 hours is required, but the same complex can be prepared in 1 hour at room temperature using the bis–NBD complex,

$[\text{Rh}(\text{NBD})_2]\text{BF}_4^-$.¹¹¹ Therefore, the bis-NBD complex was prepared as shown below,¹¹¹ and used in the hydroformylation reaction. Instead of AgBF_4 , Et_3OBF_4 was used to prepare the ionic complex since EtCl and Et_2O are the by-products, which are volatile and easily removed, unlike AgCl .¹¹³

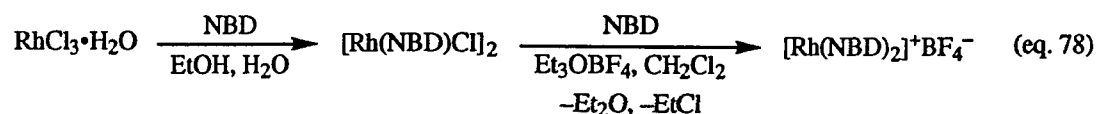

The feasibility of forming the desired arene complex *in situ* was examined by pretreating $[\text{Rh}(\text{NBD})_2]^+\text{BF}_4^-$ with 5 equivalents of toluene in CHCl_3 for 1 hour at 50°C under CO and H_2 and for 1 hour at 100°C . After this procedure, the autoclave was cooled and the substrate (1-decene) was added. After 20 hours at 55°C , there was a considerable amount of hydroformylation. To check that $[\text{Rh}(\text{NBD})_2]^+\text{BF}_4^-$ did not catalyze the reaction under these conditions, the reaction was repeated without added toluene. It also worked. Even preheating the $[\text{Rh}(\text{NBD})_2]^+\text{BF}_4^-$ complex at 100°C for 5 hours in CHCl_3 in the absence of added substrate was not sufficient to decompose it.

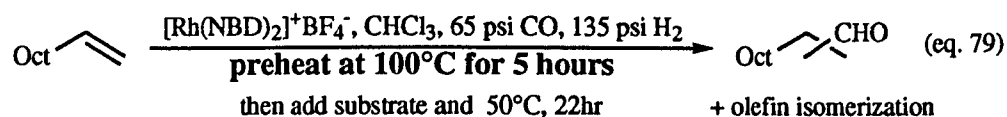

Since the preparation of the arene complexes *in situ*, was unsuccessful, the toluene complex was prepared as described in the literature,¹¹¹ and the complex with the TBDMS ether of 1-phenylethanol (**40**) was prepared using the same method (equations 80 and 81). Although both reactions were successful, as evidenced by the upfield shift of the aromatic protons in the ^1H NMR, a considerable amount (ca. 60%) of protodesilation was observed in the TBDMS protected 1-phenylethanol case.

Since purification of $[\text{Rh}(\text{NBD})_2]^+\text{BF}_4^-$ was difficult, we attempted the preparation of the arene-Rh complex directly from $[\text{Rh}(\text{NBD})\text{Cl}]_2$ using a modification of the procedure described by Schrock and Osborn.¹¹⁴ This would also permit the preparation of the desired complex from $\text{RhCl}_3 \cdot \text{H}_2\text{O}$ in 2 steps instead of 3.

It was reported by Schrock and Osborn¹¹⁴ that treatment of $[\text{Rh}(\text{NBD})\text{Cl}]_2$ in THF with AgBF_4 yielded the highly reactive and coordinatively unsaturated $[\text{Rh}(\text{NBD})]^+\text{BF}_4^-$. This material was treated with a variety of ligands, including NBD yielding $[\text{Rh}(\text{NBD})_2]^+\text{BF}_4^-$ and arenes yielding the corresponding arene complexes. Since the rhodium complex is coordinatively unsaturated in this system, preparation of the arene complex should be more facile than the previous method which required dissociation of one of the dienes from co-ordinatively saturated $[\text{Rh}(\text{NBD})_2]^+\text{BF}_4^-$.

Due to initial difficulties encountered with $\text{Et}_3\text{O}^+\text{BF}_4^-$ catalyzed polymerization of THF, the arene complexes were prepared from $[\text{Rh}(\text{NBD})\text{Cl}]_2$ using $\text{Et}_3\text{O}^+\text{BF}_4^-$ in CH_2Cl_2 . Thus, $[\text{Rh}(\text{NBD})\text{Cl}]_2$ was dissolved in CH_2Cl_2 and the arene was added to the yellow solution followed by one equivalent of $\text{Et}_3\text{O}^+\text{BF}_4^-$ whereupon the solution immediately became red.¹¹⁵ The reaction was first performed using the racemic ester, and then repeated with the enantiopure compound. The crude ^1H NMR spectrum for this reaction is shown in Figure 10 and a spectrum of the arene itself (42) is shown in Figure 9 for comparison.

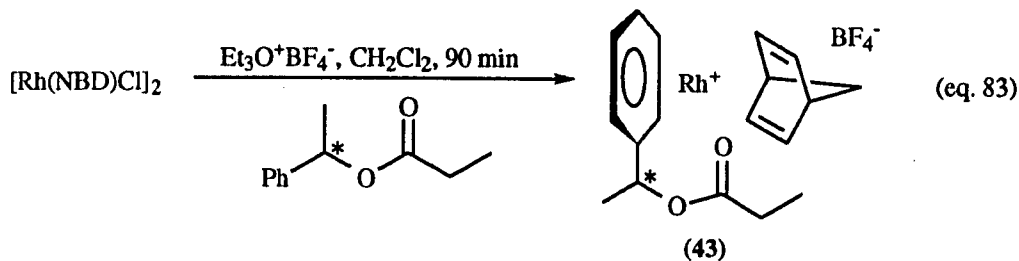

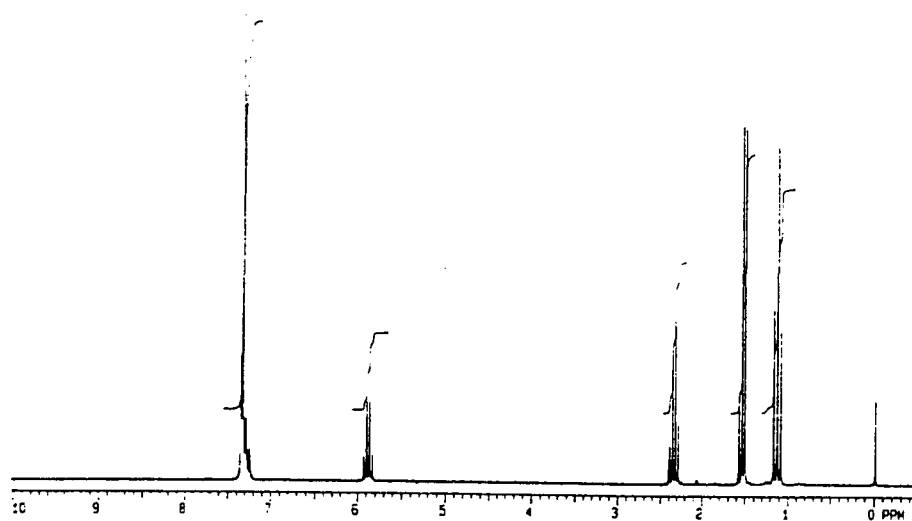

Figure 9: Ethyl Ester of (S)-(-)-1-Phenylethanol (42).

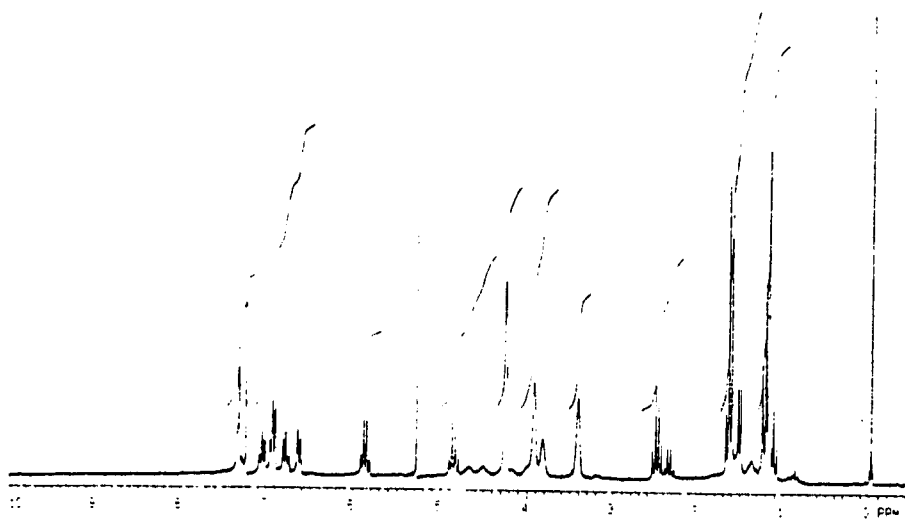
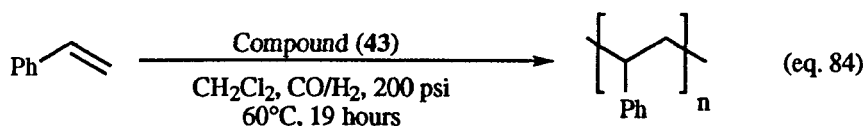
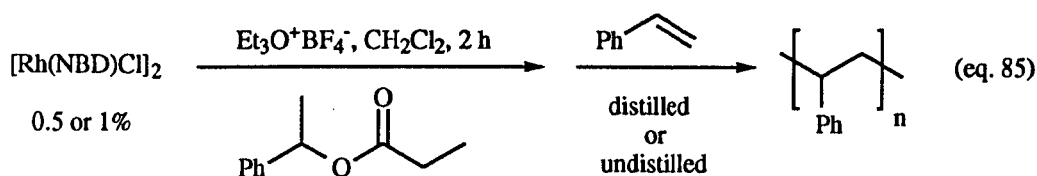

Figure 10: Preparation of Chiral-Non Racemic Rhodium-Arene Ester Complex (43).

Having prepared the desired arene complexes, we examined their catalytic activity in the hydroformylation of styrene. Much to our dismay, the major product of the reaction was polystyrene, with only a very small amount of the desired aldehyde being produced. At the time the polymerization was attributed to the very small amount of catalyst used (0.1%).



By performing the reaction described in equation 83 in an autoclave liner, the Rh-racemic arene complex (43) could be prepared conveniently and used as a solution in CH_2Cl_2 (see experimental section). Using this technique, the hydroformylation of styrene was attempted with 0.5 or 1.0% catalyst, but again there was virtually no hydroformylation. Using higher CO/H_2 pressures did not suppress the polymerization. Finally, the reaction was performed using undistilled styrene in the hope that the inhibitor present would prevent the polymerization but it did not. Vinyl naphthalene was examined as a substrate but it also polymerized.



Based on these results, it was concluded that the Rh-arene complex did not catalyze the hydroformylation of styrene, and so aliphatic olefins which should not polymerize as readily were examined. Arene complex 43 was prepared as previously described and the reaction was carried out with 1-decene, affording a mixture of

aldehyde products which were isolated by reduced pressure distillation in 50% yield (equation 86).

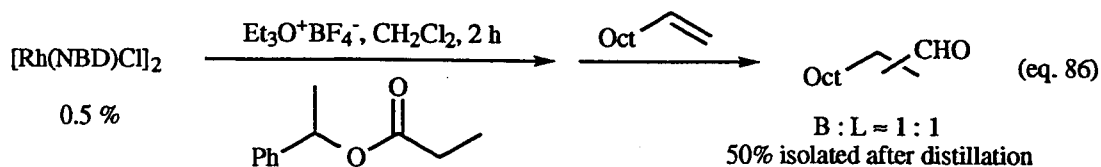

Since the rhodium–arene complex also catalyzed the isomerization, there was more than one branched aldehyde produced. Examination of the ^1H NMR spectrum in the presence of several chiral shift reagents gave no separation. The esters of Mosher's acid were prepared by reduction of the mixture of aldehydes to the corresponding alcohols with NaBH_4 and reaction with Mosher's acid chloride (generated from the acid and oxalyl chloride). The ^1H NMR spectra of both the alcohols and the esters were complex, indicating the presence of several positional isomers, and the ^{19}F NMR did not give any useful information.

Of the substrates examined, the only one that was suitable was vinyltriethylsilane. In this case, isomerization of the olefin is not possible, but the branched isomer was completely converted to the enol silyl ether which is useless for measuring ee, and so our research into the chiral arene complexes as hydroformylation catalysts was discontinued.

3.3 Conclusions

Rhodium complexes of chiral and achiral arenes have been prepared by a variety of methods. These complexes were shown to catalyze the hydroformylation of vinyltriethylsilane. The toluene complex Rh^{tol} (**40**) gave a reaction profile similar to Rh^{zw} , and unlike Rh^+ , it catalyzed the hydroformylation of vinyltriethylsilane in ether

and in dichloromethane. The 1-phenylethanol complexes also catalyzed the hydroformylation of vinyltriethylsilane, but all of the branched isomer was converted into its enol silyl ether.

Although we were able to develop conditions under which the arene complex could be prepared *in situ*, all attempts to hydroformylate styrene led to polymerization. Vinylnaphthalene was also polymerized under the reaction conditions. The fact that the arene complexes did not catalyze the hydroformylation but instead promoted the polymerization of styrene and vinylnaphthalene is itself indicative that the arene remains bound to the metal and changes its reactivity. Terminal olefins such as hexene, octene or decene were poor substrates due to the considerable isomerization of the starting material.

Chapter Four: The Carbonylation of Carbon-Nitrogen and Carbon-Sulfur Bonds in Six Membered Rings.

4.1 Introduction: Carbonylative Ring Expansions

A considerable amount of research into the carbonylative ring expansion of heterocycles has been reported in the last 15 years. As noted in the introduction, this research began with the discovery by Alper et al.^{52a,b} that the palladium catalyzed carbonylation of azirines occurred with ring expansion and coupling yielding a bicyclic lactam product (Chapter 1, equation 24). This reaction was also applicable to aziridines, and a unique difference in the reactivity of the aziridine and the regiochemistry of the insertion was observed depending on the metal used. Using the dimer of rhodium carbonyl chloride, only 2-aryl aziridines were reactive and carbon monoxide was inserted into the *more* substituted C-N bond (equation 87).⁵⁰ With catalytic amounts of cobalt carbonyl, 2-alkylaziridines were reactive and carbon monoxide was inserted regioselectively into the *less* substituted C-N bond.¹¹⁶ Finally, when the carbonylation was promoted by excess nickel carbonyl and iodide ion, the less hindered bond was also carbonylated.¹¹⁷

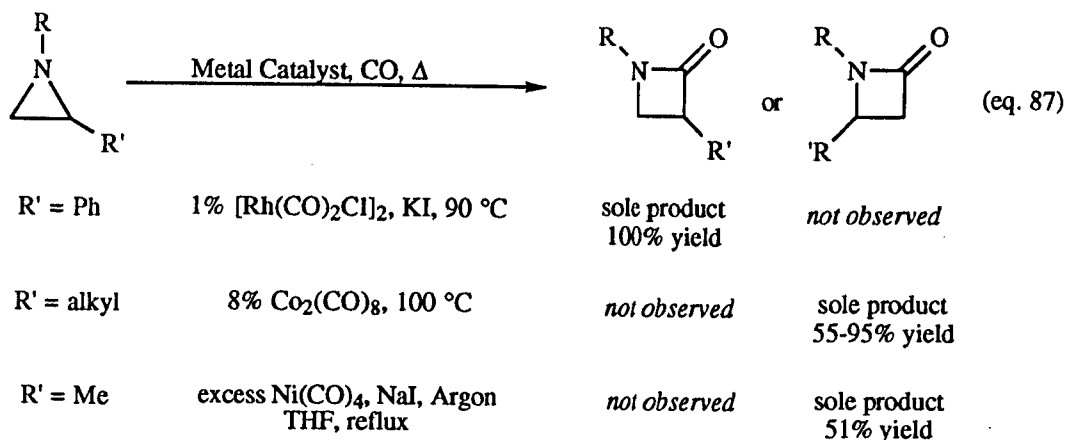

More highly substituted aziridine derivatives can also be carbonylated using rhodium, cobalt or palladium catalysts. Alper and Roberto reported the carbonylation of aziridinones using either rhodium carbonyl as the catalyst or stoichiometric amounts of dicobalt octacarbonyl under mild conditions (equation 88).^{118a}

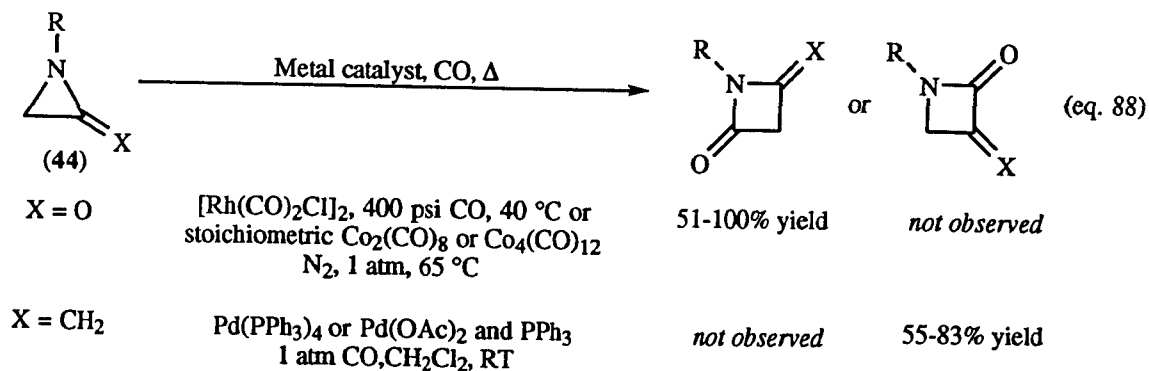

The carbonylation of the related exo-methyleneaziridine (**44**, X = CH₂) occurred at room temperature with only one atmosphere of carbon monoxide to yield the product of insertion into the more substituted C–N bond. Both Pd(PPh₃)₄ and Pd(OAc)₂/PPh₃ were effective catalysts for this mild and regioselective carbonylation reaction.^{118b}

The carbonylation of four membered ring heterocycles was also feasible, and again the position of the carbonylation is directed by the nature of the 2-substituent. With dicobalt octacarbonyl as the catalyst, 2-arylazetidines give the lactam resulting from the insertion of carbon monoxide into the more substituted C–N bond while 2-alkylazetidines, undergo carbonylation at the less substituted C–N bond (see equation 25).^{52c} The same substituent effect was observed in the carbonylation of pyrrolidines (**45**) to yield piperidinones (**46** and **47**), but increased yields were observed when 5% Ru₃(CO)₁₂ was used in combination with dicobalt octacarbonyl (10%).⁵⁴ Much more strenuous conditions were required for the pyrrolidine ring expansions compared to the azetidine reactions, presumably because of the strain energy present in the azetidine substrates (see equation 89).

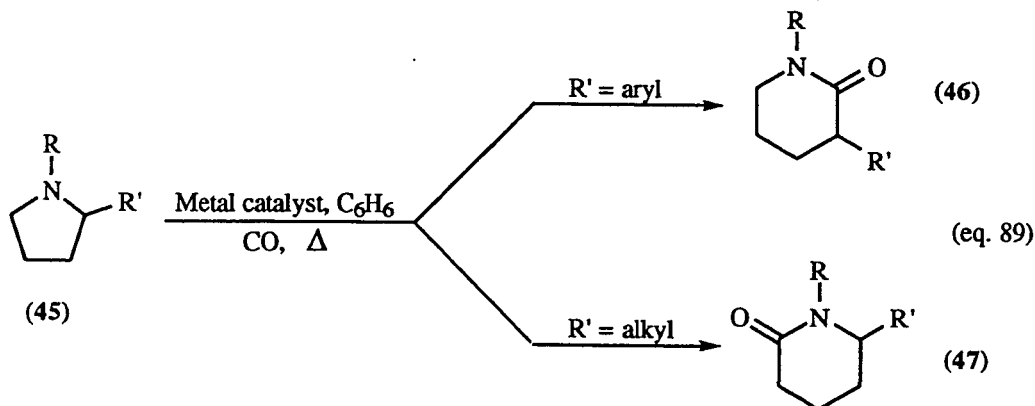

metal catalyst = Co₂(CO)₈ and Ru₃(CO)₁₂, temp = 220 °C, pressure = 1000 psi

Although a considerable amount of work has been published on carbonylative ring expansion reactions, there are no examples of the carbonylation of 6-membered ring heterocycles to yield the corresponding 7-membered ring amides or lactones. Not only are these types of compounds difficult to make by conventional routes, but some possess considerable biological activity. We were interested, therefore, in developing conditions for the carbonylation of piperidine derivatives, and applying these conditions to the synthesis of 7-membered ring lactams. Specifically we were interested in the carbonylation of quinazolin-2-ol and its derivatives since the caprolactam products have potent anti-depressant activity, belonging to the benzodiazepam family of drugs.

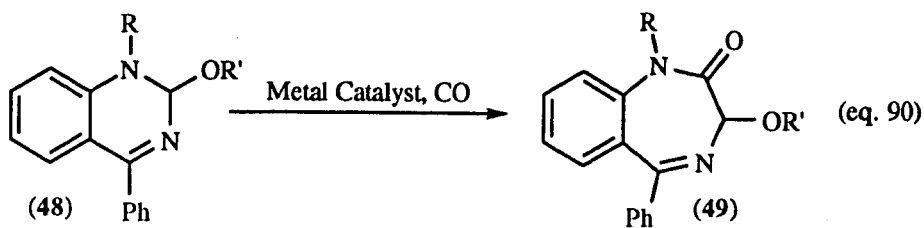

4.2 Results and Discussion

4.2.1 Carbonylation of 1-Alkyl-1,2,3,4-Tetrahydroquinolines

As a model for our final target of *N*-alkylquinazolin-2-ols (49), we chose 1-ethyl-1,2,3,4-tetrahydroquinoline (51) which was conveniently prepared from the commercially available 1,2,3,4-tetrahydroquinoline (50) and subjected to carbonylation with a variety of catalysts. The rhodium complex, $[\text{Rh}(\text{COD})\text{Cl}]_2$, was first examined since it is an effective catalyst for the carbonylation of a wide variety of heterocycles including aziridines, thiazolidines and even acyclic *N,S*-acetals. However, at temperatures of up to 180 °C under 1000 psi of CO, no carbonylation was observed after 48 hours in benzene or in *N,N*-dimethylacetamide. The addition of a variety of phosphines including Triphos and PCy_3 did not affect the carbonylation even under the severe conditions described above. The related catalysts $[\text{Rh}(\text{CO})_2\text{Cl}]_2$ and $[\text{Rh}(\text{COD})_2]^+\text{BF}_4^-$ were also tried unsuccessfully (the latter in combination with $\text{Ru}_3(\text{CO})_{12}$).

A number of cobalt and ruthenium catalysts were also examined in this reaction, since they gave good yields of the carbonylated products in the pyrrolidine series. In the majority of cases, there was no reaction, and only starting material was observed. The use of stoichiometric amounts of dicobalt octacarbonyl for 6.5 days at 210 °C resulted in the complete decomposition of the starting material. When a similar reaction was stopped after 4 days, less than 2% conversion was measured. Trirutheniumdodecacarbonyl alone did not catalyze (or promote) the carbonylation even when the reaction was run for 6.5 days at 200 °C. A cationic bis(cyclopentadiene)cobalt complex, $[\text{Co}(\text{Cp})_2]^+\text{PF}_6^-$, was also examined alone, or in combination with $\text{Ru}_3(\text{CO})_{12}$ but no reaction was observed even at temperatures > 200 °C.

An attempted carbonylation with both dicobalt octacarbonyl and ruthenium carbonyl at 180 °C gave only the starting material after 48 hours. When the temperature was

increased to 210 °C, very small amounts of three different products were detected by GC. According to the GC analysis, 95% of the volatile crude reaction mixture was the starting material, and the remaining 5% contained the dealkylated tetrahydroquinoline (50) and two other compounds. GCMS analysis showed that both of these compounds had molecular weights consistent with the insertion of CO (189 m/z). Since the amounts were so small, it was not possible to observe these compounds by NMR techniques.

Running the reaction in toluene gave virtually identical results. If THF was used as the solvent, and the reaction run for 6.5 days, a larger amount of the dealkylated compound (50, 5%) and of the carbonylated products (5 and 10%) were obtained.

Since the starting material was sensitive to light and chromatography, and the carbonylation products were obtained in low yield, their isolation was difficult. Finally, we compared the GC retention times and mass spectra of the unknown products to authentic samples prepared by independent routes. Two of the possible amide products were prepared as shown in equations 91 and 92.

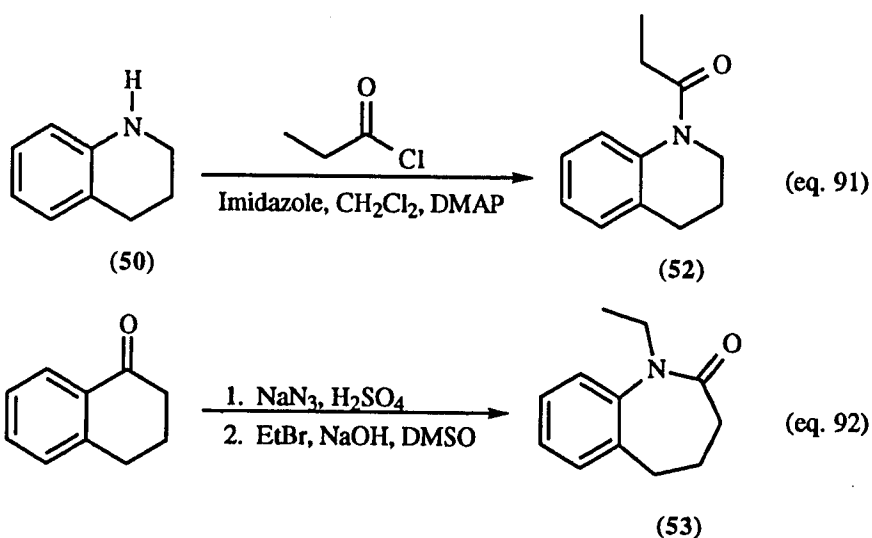

Compound 52 was synthesized by acylating 1,2,3,4-tetrahydroquinoline with propanoyl chloride. This amide would have resulted from the insertion of CO into the

acyclic C–N bond which was considered unlikely. The product of insertion into the cyclic N–alkyl bond was prepared from α -tetralone via a nitrene insertion¹²⁰ and N–alkylation of the resulting secondary amide using EtBr and NaOH_(pwr) in DMSO.¹²¹ The amide that would result from carbonylation of the N–phenyl bond (54) was not prepared due to the scarcity of methods reported for its synthesis.¹²²

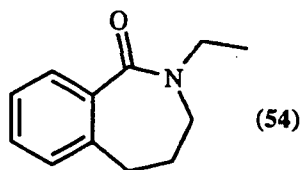

Having prepared compounds 52 and 53, we compared their retention times with those of the unknown compounds in the GC of the crude reaction mixture. The major carbonylation product had the same retention time as compound 52 which would result from insertion of CO into the *acyclic* C–N bond. Although the retention times were identical, the mass spectra were not. Both the unknown product and amide 52 had a molecular ion with $m/z = 189$, but the base peaks were different.

The second compound produced in the reaction did not have the same GC retention time as the benzazepinone derivative (53) prepared as shown in equation 92. The retention times of the two species were, however, only separated by 0.1 minutes. Furthermore, the mass spectra of compound 53 and of the unknown carbonylation product both displayed an M^+ of 189 m/z , but again the base peaks and the rest of the spectra were different. Therefore, since the two compounds had GC retention times very close to amides 53 and 52 and had molecular ions indicative of CO insertion products, we can state that CO insertion had in fact occurred. However, the structures of the carbonylated products could not be determined. One possibility is compound 54, and if the unknown material could be isolated, its IR and NMR data could be compared with that given in the literature.^{120, 122}

The carbonylation was also attempted with a variety of palladium complexes including palladium acetate with phosphine additives such as PPh₃ and DPPB but no

reaction was observed after extended periods of time. The divalent complexes $\text{Pd}(\text{AsPh}_3)_2\text{Cl}_2$, $\text{Pd}(\text{PCy}_3)_2\text{Cl}_2$, and $[\text{Pd}(\text{CH}_3\text{CN})_4]^{2+}(\text{BF}_4^-)_2$ were also tried unsuccessfully alone or in combination with a variety of additives, but only the last complex gave some product if 1–2 equivalents of CuCl_2 (relative to the starting material) were added and the reaction run for 7 days at 210 °C.

Analysis of the crude reaction mixture by GC showed that as in the cobalt/ruthenium system, more than 85% of the reaction mixture was the starting material (compound 51). The three products previously discussed in the Co/Ru system were also present in small amounts in this reaction mixture. Although workup was found to be difficult because the large amounts of metal salts present, dilution of the system with THF *before* the reaction allowed us to remove most of the metal species by precipitation with pentane and filtration through celite. In certain experiments, a product could be observed in the IR and ^1H NMR spectra that resulted from the insertion of carbon monoxide into the C–O bond of THF (δ -valerolactone)!

Despite the extreme conditions and low turnover numbers, we attempted to apply these results to the carbonylation of the target compound (55) in the hope that the increased functionality would improve the activity towards carbonylation. The required heterocycle was prepared as described in the following section.

4.2.2 Synthesis and Carbonylation of Compound 55.

The method chosen for the synthesis of compound 55 began with the synthesis of quinazolinone 56 as described by Katritzky et al.¹²³ Compound 56 was obtained as a by-product in the synthesis of 2-ethylamino-benzophenone 57 as shown in Scheme 16.

Scheme 16: Preparation of Quinazolinone (56).

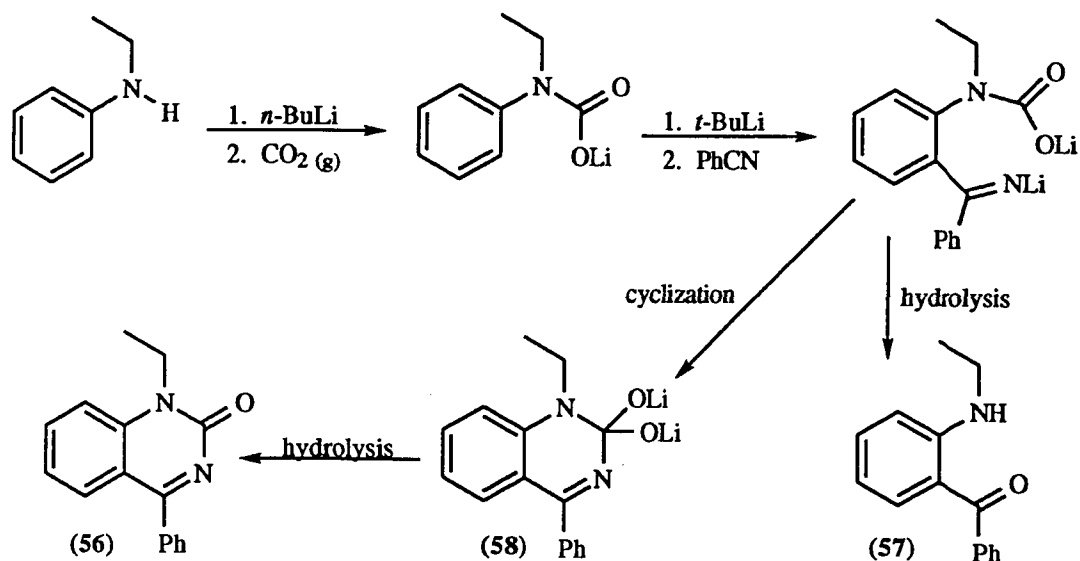

It was hoped that modification of the published procedure (which was presumably optimized for the production of the benzophenone amine) would allow us to obtain the desired compound (56) as the major product. Even if separation of compounds 56 and 57 was necessary, the desired heterocycle could be assembled very quickly. Selective reduction of the carbamate $\text{C}=\text{O}$ in the presence of the imine $\text{C}=\text{N}$ and alkylation would then be required to prepare the starting material for the carbonylation reaction (55).

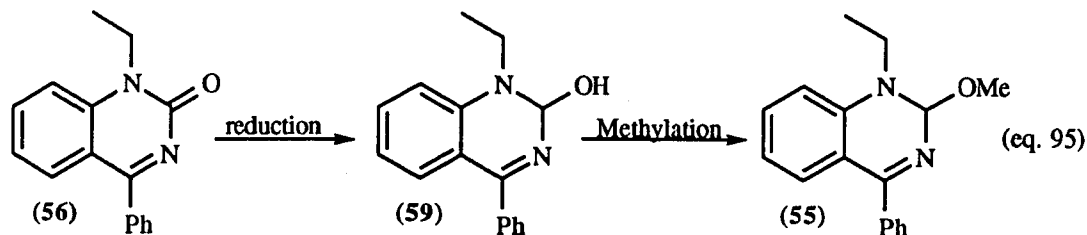

Thus, purified *N*-ethylaniline was deprotonated with $n\text{-BuLi}$ and bubbling of dry CO_2 through the reaction mixture generated $\text{PhN}(\text{Et})\text{CO}_2\text{Li}$. Ortho-lithiation with $t\text{-BuLi}$ was directed by the NCO_2Li group, and benzonitrile was used to trap the resulting aryl

lithium. From this dilithio intermediate, hydrolysis gave the ortho-aminated benzophenone **57**. Alternatively, cyclization to a dilithioketal (**58**) followed by hydrolysis generated the desired quinazolinone **56**. Therefore, the heterocyclic skeleton (**56**) could be synthesized in one pot from *N*-ethylaniline, carbon dioxide and benzonitrile.

However, the conditions described in the Katritzky paper gave no product in our hands after several attempts. Decreasing the temperature at which CO₂ was bubbled through the solution of PhN(Et)Li to -5 °C (ice-NaCl bath), increasing the bubbling time from 5 to 20 minutes and allowing the reaction to warm to room temperature overnight, were found to be vital to the success of the reaction. We believe that these first two modifications are related to the instability of the lithio carbamate at temperatures greater than 0 °C. (See the Experimental Section for the exact procedure employed.) Under these conditions, the desired product was produced in only 20% yield after recrystallization.

A number of methods were examined to increase the yield of compound **56** including the addition of amine ligands such as TMEDA and DABCO, which had an imperceptible effect on the reaction. A reaction performed in the presence of 2 equivalents of HMPA gave only the undesired benzophenone amine (**57**). We also examined a variety of different solvents and combinations of solvents for the reaction, but the yield of the desired product could not be improved. Therefore, the reaction was performed without additives as described in the experimental section and quinazolinone **56** was separated from the unwanted (2-ethylamino)benzophenone (**57**). Using this procedure, we were able to obtain the desired product in 25% yield (after recrystallization) on an 80 mmol scale.

The separation of the two products was accomplished mainly by treatment of the mixture with aqueous acid and extraction of the aqueous layer with chloroform. In fact, depending on the method used for the hydrolysis of the dilithioketal, the separation of the two products could be achieved during workup of the reaction. Quinazolin-2-one **56** could be further purified by recrystallization in a reproducible 20-25% yield. From this

material, compound **55** was obtained in 2 steps via a $\text{NaBH}_4/\text{CeCl}_3 \cdot 7\text{H}_2\text{O}$ reduction and alkylation with MeI and NaH.

Having obtained the desired product, we attempted the carbonylation under the Pd/Cu conditions as previously described, but there was no reaction. Since we had prepared the substrate, a variety of other conditions were tried. Using $\text{Pd}(\text{OAc})_2$, PdL_2Cl_2 (where $\text{L} = \text{AsPh}_3$ or PCy_3) or $[\text{Pd}(\text{CH}_3\text{CN})_4]^{2+}(\text{BF}_4^-)_2$ no carbonylation was observed. The last complex was tried, as before, with added CuCl_2 and PPh_3 , but the starting material was recovered unchanged. Cobalt complexes were also examined alone or in mixed systems with ruthenium. The combination of $\text{Co}_2(\text{CO})_8$ and $\text{Ru}_3(\text{CO})_{12}$ which gave ca. 15% total carbonylation in the model compound did not catalyze the carbonylation even when the reaction was performed at 235 °C. Similarly, compound **55** was unreactive in the presence of stoichiometric amounts of dicobalt octacarbonyl. Some cobalt (II) complexes of the general formula CoL_2Cl_2 (where $\text{L} = \text{PPh}_3$ or PCy_3) were also tried alone or in the presence of NaOAc without success.

Finally, the carbonylation of compound **55** was examined with $[\text{Rh}(\text{COD})\text{Cl}]_2$ alone or with additives including KI, I_2 , AsPh_3 and NaOAc in benzene, dichloromethane, THF and DMAC. These combinations were unsuccessful. The $[\text{Rh}(\text{COD})\text{Cl}]_2$ catalyzed carbonylation was also attempted in the presence a variety of Lewis acids such as CeCl_3 , TiCl_4 and $\text{B}(\text{OEt})_3$. Under all of these conditions, compound **55** was unreactive. If a stoichiometric amount of I_2 was used in combination with $[\text{Rh}(\text{COD})\text{Cl}]_2$, decomposition of the starting material was observed, but no carbonylation products could be detected. The addition of catalytic quantities of I_2 gave no reaction.

Considering the unreactivity of compound **55**, we returned to the 1-alkyl-1, 2, 3, 4-tetrahydroquinoline series and examined the effect of changing the substituent on nitrogen.

4.2.3 The Synthesis and Attempted Carbonylation of 1-Alkyl Tetrahydroquinoline derivatives (60, 61 and 63).

Alper and Roberto showed in their work with azetidines^{52c} that the nature of the substituent on nitrogen had a dramatic effect on the facility of the carbonylation, with *N*-methylene ketones and *N*-methylene esters being the most reactive towards CO insertion. We therefore prepared the methylene ester and methylene ketone derivatives of compound (50) as shown in equations 96 and 97 and examined their behavior under carbonylation conditions.

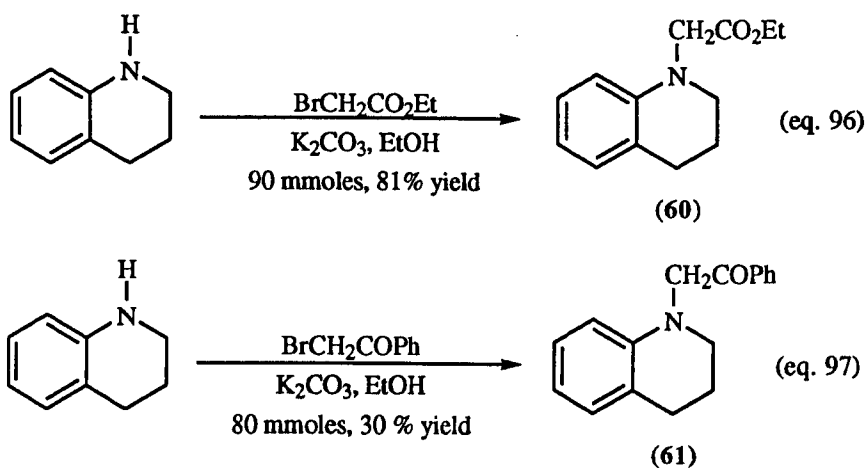

We began with compound 61 and subjected it to the conditions previously employed in the carbonylation of compound 51, namely 10% $[\text{Pd}(\text{CH}_3\text{CN})_4]^{2+}(\text{BF}_4)_2^-$, 120% CuCl_2 , 1200 psi CO, 200 °C for 7 days. After this time, no starting material remained and several compounds were produced. When the reaction was run for 12 hours, only traces of the starting material were observed by TLC. Under these conditions, acetylene 62 was obtained in 21% yield along with the other unidentified products which did not contain CO (according to ^{13}C NMR and IR spectra) as shown in equation 98.

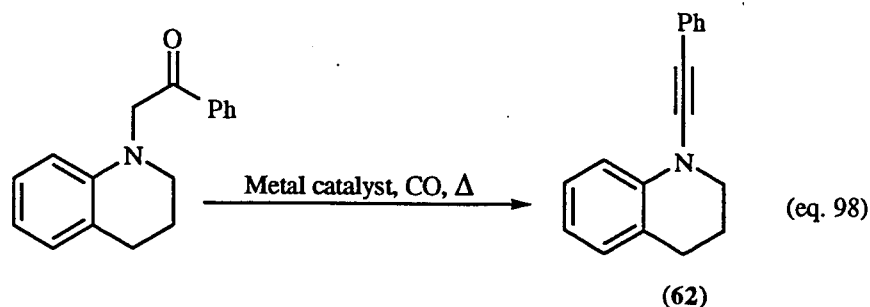

metal catalyst = $[\text{Pd}(\text{CH}_3\text{CN})_4]^{2+}(\text{BF}_4^-)_2$ and CuCl_2 yield (62) = 21%
 conditions = 200 °C, 1200 psi, 12 h

metal catalyst = $[\text{Rh}(\text{CO})_2\text{Cl}]_2$, KI yield (62) = 16%
 conditions = 180 °C, 1200 psi CO, 36 h

This dehydration reaction was also observed in lower yield using $[\text{Rh}(\text{CO})_2\text{Cl}]_2$ with added KI as shown in equation 98. In this case, a significant amount of starting material remained (TLC). The acetylene (62) was isolated in 16% yield after column chromatography.

Methylene ester 60 was subjected to the conditions described in equation 98 (with palladium and copper) but only the starting material was observed by TLC. To test other *N*-methylene phenyl ketones in this reaction, the derivative of *N*-methylaniline was prepared as shown in equation 99.

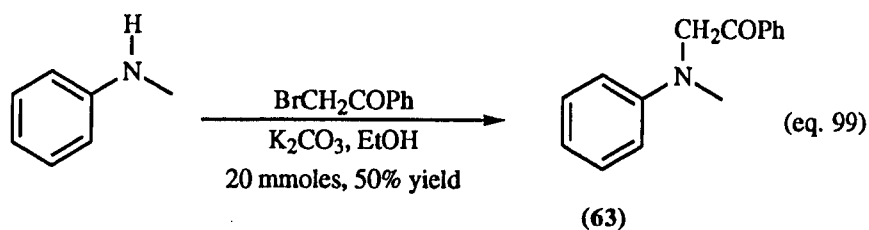

After reaction with palladium and copper catalysts (see equation 98) for 19 hours at 100 °C, mostly the starting material remained. Thus, the enolization–dehydration reaction seemed to lack generality.

Considering some recent results from our laboratories⁵⁵, we turned our attention to another system containing sulfur and nitrogen in a 1, 3–relationship.

4.2.4 Synthesis and Attempted Carbonylation of 1,3-Thiazane Derivatives (67, 68 and 70).

It has recently been reported by Khumtaveeporn and Alper⁵⁵ that the carbonylation of *acyclic* carbon-heteroatom bonds can be effected if a system containing both sulfur and nitrogen in a 1, 3-relationship is employed (see equation 30, Chapter 1). A benzyl substituent on sulfur was found to be essential for the reaction, and carbonylation occurred into the benzylic C-S bond. When a system with two benzylic substituents (64) was prepared, it underwent carbonylation regioselectively as shown in Scheme 17.

Scheme 17: Regioselectivity of Carbonylation of Acyclic N,S-Acetals

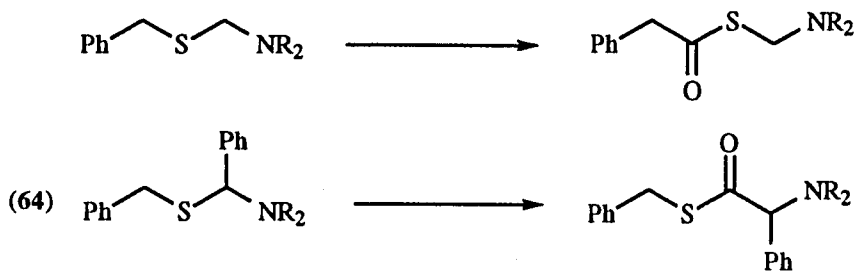

Khumtaveeporn and Alper also reported the carbonylation of cyclic *N,S*-acetals as shown in equation 29 (Chapter 1). Surprisingly, the conditions required to effect carbonylation of the cyclic system were more severe than those employed with the acyclic substrates (180 °C for 2 d compared to 140 °C for 1 d). If the presence of sulfur facilitated carbonylation so much that an acyclic system could be carbonylated under reasonably mild conditions, we postulated that a six membered ring *N,S*-acetal might also be amenable to carbonylation. It should be noted that carbonylation of the six-membered ring might be more difficult to carry out than either of these systems since the ring expansion introduces ring strain in the metalacyclic intermediates (e.g. compound 27 in Scheme 11).¹¹⁹

The desired substrates (**67** and **68**) for a 6 to 7 carbonylative ring expansion were prepared in four steps from commercially available 3-amino-1-propanol as shown in Scheme 18. These substrates contain the 1,3-*N,S*-acetal unit and a benzylic substituent which were shown to be essential in the 5-membered ring systems.⁵⁵ This sequence would also permit the preparation of several analogs from a common intermediate (**66**).

Scheme 18: Preparation of 2-Phenyl-5,6-dihydro-1,3-thiazine-4H (66).

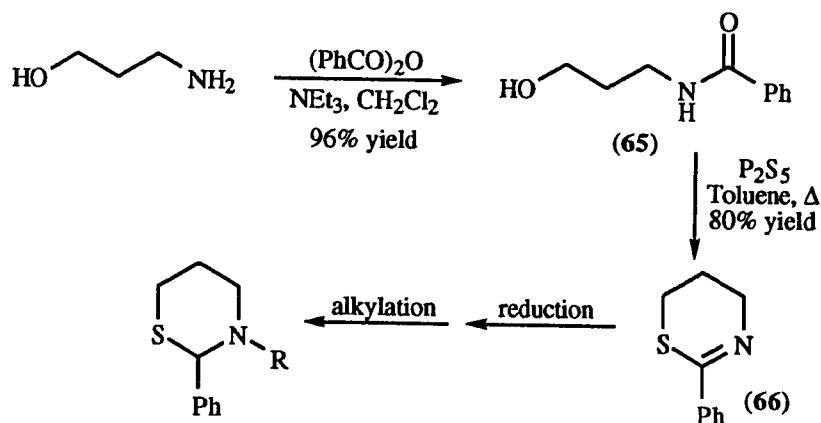

Thus treatment of 3-amino-1-propanol with benzoic anhydride and triethylamine in CH_2Cl_2 yielded 96% of benzoyl amide **65**. When this amide was reacted with P_2S_5 in refluxing toluene, thiazine **66** was isolated in 80% yield.¹²⁴ The next step, reduction of the imine functionality, was more challenging. Reduction with sodium borohydride in methanol with added HCl as described by Meyers et al.¹²⁵ failed in our hands. Similarly, sodium cyanoborohydride did not effect the reduction in the presence of HCl. Finally, we found that quaternization followed by reduction was effective. Thiazine **66** was treated with neat methyl iodide overnight to generate the methyl iminium salt which was purified by removing the methyl iodide *in vacuo* and washing the resulting solid with dry ether. Dissolution in methanol and addition of sodium borohydride yielded the desired thiazane **67** in 78% yield from thiazine **66** (equation 101).

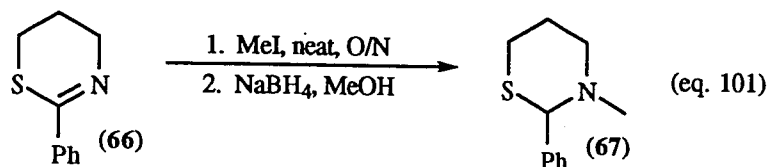

Having prepared the desired compound, we examined its carbonylation under the conditions found to be most effective for the related 5-membered ring and acyclic *N,S*-acetals. Thus, the carbonylation of compound **67** was attempted using $[\text{Rh}(\text{COD})\text{Cl}]_2$ and KI in benzene under 1000 psi of CO at 180 °C for 48 hours.

^1H NMR analysis of the crude reaction mixture obtained by simple removal of the solvent and volatiles revealed only the starting material. The reaction was repeated at 220 °C for 2 days using 10% catalyst. Under these conditions, there was also no reaction.

As previously discussed, methylene ketone and methylene ester side chains are known to promote carbonylation. Therefore we attempted to prepare these derivatives by the same method used in the synthesis of compound **67**. Replacement of methyl iodide with ethyl bromo acetate was effective yielding compound **68** in 73% yield over the two steps, but acetophenone derivative **69** could not be prepared using this method presumably due to complications resulting from competitive reduction of the ketone (see equations 102 and 103).

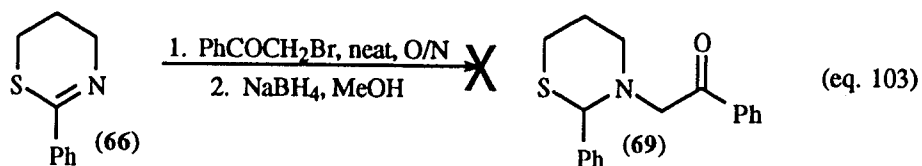
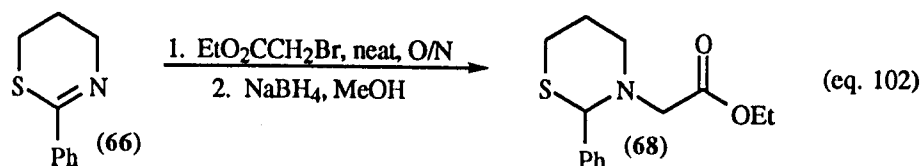

The carbonylation of the ethyl ester was attempted using the rhodium/KI system previously described at 220 °C for 2 days. Under these conditions, several unidentifiable compounds were produced, none of which contained any CO according to ^{13}C NMR. When the reaction was run at lower temperature (180 or 170 °C), there was no reaction and only the starting material was observed in the crude ^1H NMR. Since the Pd/Cu system seemed promising for the carbonylation of tetrahydroquinoline systems, we examined these conditions for the carbonylation of compound **68**.

Thus, compound **68** was treated with 10% $[\text{Pd}(\text{CH}_3\text{CN})_4]^{2+}(\text{BF}_4^-)_2$ and 120% CuCl_2 in THF under 1200 psi of CO at 200 °C. After 5 days, the reaction was worked up and mostly the starting material remained, but a small amount of a less polar compound could be observed by TLC. IR analysis indicated the presence of a carbonyl moiety, although the position of the stretch was higher than expected (1710 cm^{-1}). Isolation of this material was unsuccessful. The reaction was repeated with the benzyl derivative (**70**)¹²⁶ under the aforementioned conditions at 170 °C for 2.5 days. TLC analysis of the crude reaction mixture showed that the reactant had been consumed. In fact, the starting material was completely consumed when the reaction was run at 120 °C for only 12 hours. If the reaction mixture resulting from removal of the copper salts by precipitation and filtration was not subjected to high vacuum, we were able to isolate benzaldehyde from the reaction mixture and characterize it by ^1H and ^{13}C NMR (equation 104). In the previously described reactions of compound **68**, the less polar product observed in the TLC of the crude reaction mixture was probably also from deketalization.

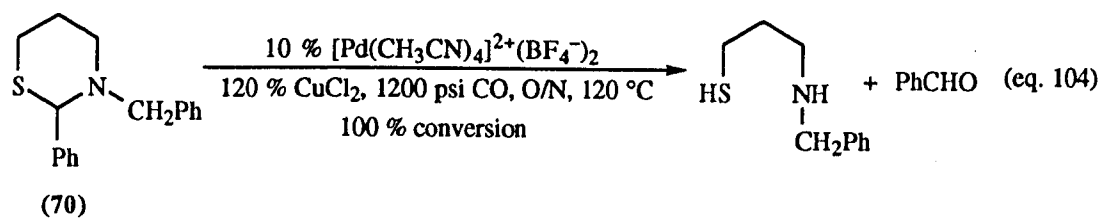

Unlike thiazolidines and acyclic *N,S*-ketals, 1,3-thiazanes were not susceptible to carbonylation using $[\text{Rh}(\text{COD})\text{Cl}]_2$ and KI regardless of the nature of the substitution on nitrogen or the severity of the reaction conditions. Furthermore, the conditions developed for the tetrahydroquinoline systems gave varying degrees of CuCl_2 -promoted deketalization producing benzaldehyde. The final substrate examined was a dihydro-thiazine. It was hoped that an endocyclic olefin would increase the reactivity of the ring system and facilitate carbonylation by the formation of a π -allyl intermediate.

4.2.5 The Synthesis and Attempted Carbonylation of 2*H*-3,6-Dihydro-1,3-thiazine Derivatives (75-78).

There are two examples in the literature of the ring expansion of nitrogen-containing substrates that involve π -allyl formation. When azetidine **71** was examined under the conditions employed for the carbonylation of simple alkyl or aryl azetidines, the expected pyrrolidinone (**73**) was not obtained.^{52c} Instead, a caprolactam derivative (**72**) was isolated in which the olefinic side chain had been incorporated into the ring (equation 105). The formation of a π -allyl metal intermediate was proposed to be a key species in the carbonylation.

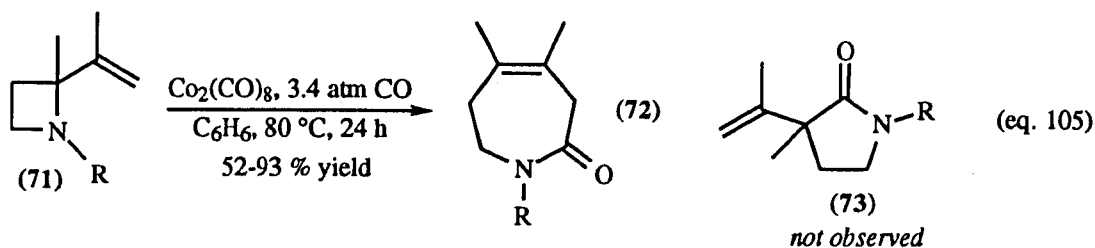

Another example is the carbonylation of a vinyl aziridine (**74**).¹²⁷ This reaction occurs under much milder conditions than generally required for the carbonylation of

simple allylamines (1 atmosphere of carbon monoxide at room temperature), which is likely attributed to the energy released on opening of the aziridine ring. Another nice feature of this reaction is that although the starting aziridine is a mixture of *cis* and *trans* isomers, only the *trans* product is isolated.

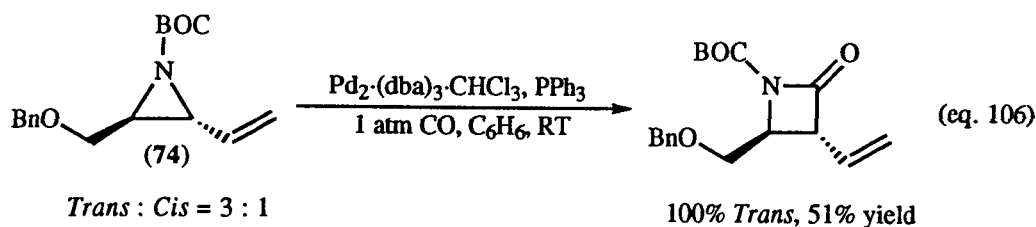

Thus it was hoped that the inclusion of an olefin in the 6-membered ring would facilitate carbonylation. The general structure of the final substrate examined is shown below (75).

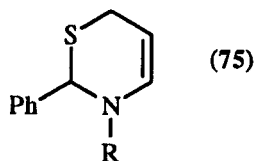

Thiobenzamide was the starting material for the synthesis of the desired heterocycle. Although thionation of benzamide proceeded smoothly with Lawesson's reagent,¹²⁸ separation of the product from the spent reagent was not trivial. When a mixture of PhCSNH₂ and spent Lawesson's reagent was used in the next step, (equation 108) compound 76 was obtained in 33% yield. However, treatment of benzamide with P₂S₅ and Na₂CO₃ in refluxing benzene for 2h gave the desired product cleanly in 25% yield after purification (equation 107). The starting materials for this reaction are readily available and amenable to scale up (25% yield of the PhCSNH₂ was obtained in a 165 mmol reaction).

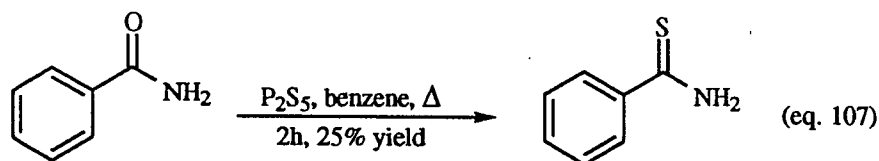

The next step was reaction of thiobenzamide with the dimethyl ketal of DMF in chloroform.¹²⁹ This reaction proceeded nicely yielding a bright red solution soon after the addition of the $(\text{MeO})_2\text{CNMe}_2$. Purification by chromatography afforded **76** in 53% yield (30 mmole scale) as a bright red solid.

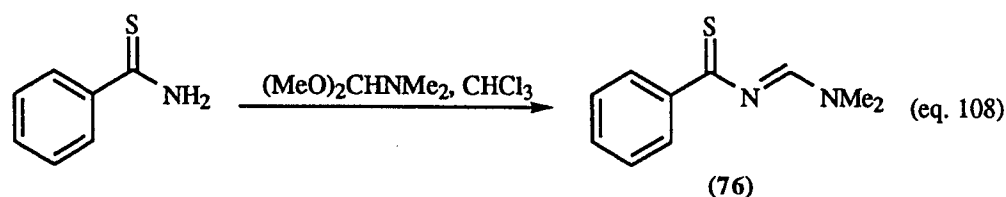

The 6-membered ring was formed by cycloaddition of compound **76** and methyl vinyl ketone as shown in equation 109.¹²⁹ The initial product of the reaction (**77**) eliminates dimethylamine *in situ* to generate the highly conjugated thiazine system (**78**). The cycloaddition could be easily monitored by TLC which clearly showed the disappearance of the red starting materials and the formation of a less polar yellow compound (see Experimental Section for details). Purification by chromatography gave the pure material in 84% yield on a small scale (1 mmol) and 76% yield on a 30 mmol scale.

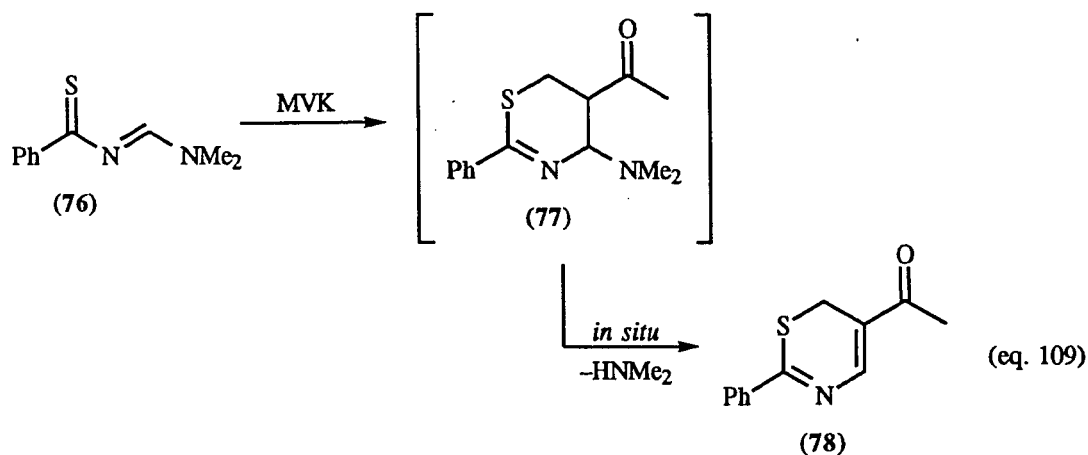

The next step was reduction of the imine C=N. Using a published procedure,¹³⁰ we were able to affect the desired reduction in good yield. Thus treatment of compound **78** with sodium cyanoborohydride in the presence of HCl using Bromocresol green as the indicator gave the desired product (**79**) in 80% yield after purification (equation 110).

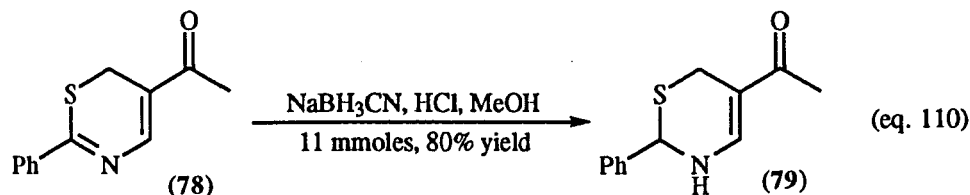

A benzoyl group was chosen as the protecting group for the secondary amine in order to decrease conjugation of the amine and the alkene by “tying up” the lone pair with the amide. Protection as the benzoyl ester was accomplished by treatment of compound **79** with benzoyl chloride in the presence of triethylamine. Surprisingly, the reaction did not go to completion unless 2 equivalents of benzoyl chloride were used. Treatment of compound **79** with 1.2 equivalents of PhCOCl and 1.2 equivalents of triethylamine in CH₂Cl₂ gave the desired product in 53% yield with only 78% conversion of the starting material. When 2 equivalents of benzoyl chloride were used, the desired compound could be obtained in 94% yield (equation 111).

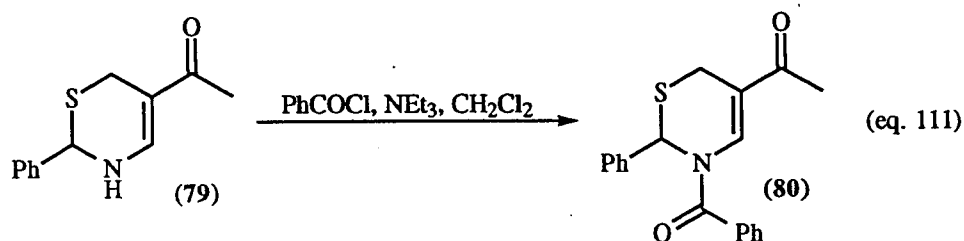

Having thus prepared the ring system, we attempted the carbonylative ring expansion under the conditions developed for the carbonylation of allyl sulfides (see Chapter 5), namely 10% Pd(OAc)₂, 10% DPPP, 1200 psi CO, in toluene at 140 °C for 2 days. Under these conditions, the starting material was recovered unchanged. Tetrakis(triphenylphosphine)palladium and ruthenium carbonyl were also tried unsuccessfully for the carbonylation of compound **80**.

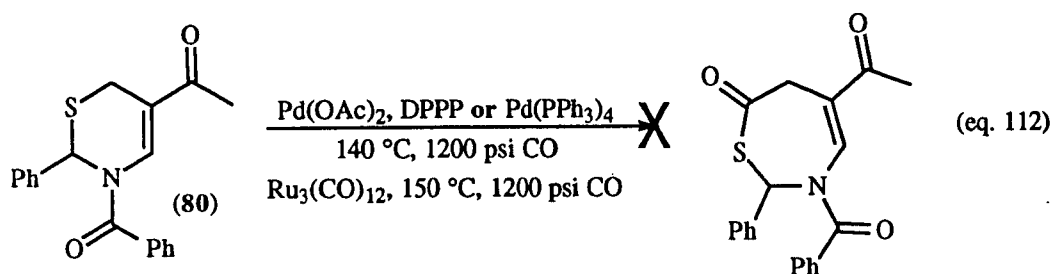

It is known that reducing the basicity of the alkene by conjugation, for example in an enone, decreases the reactivity of the olefin in palladium-catalyzed alkylation reactions. Therefore, the C=O of the enone was reduced to the alkene (**81**) using a literature method which required treatment with excess Et₃SiH and BF₃·Et₂O at 80 °C in the absence of solvent.¹³¹ Enone (**80**) was subjected to these rather vigorous conditions and after workup gave 35% of a material which appeared to be the desired alkene. The spectra of this material were complicated by the presence of amide rotamers. Cooling to -20 °C was sufficient to freeze out the rotamers and permit interpretation of the spectra (equation 113).

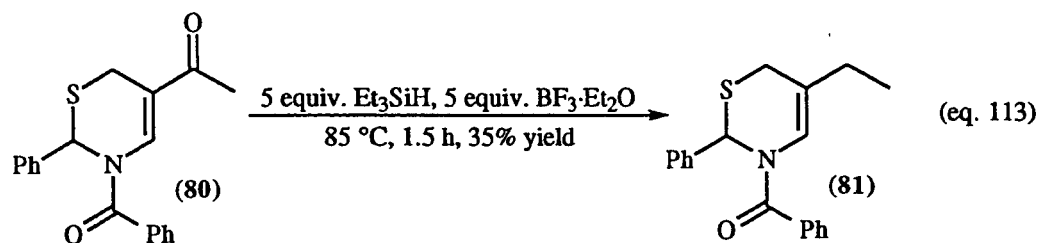

Finally, the carbonylation of compound **81** was attempted with catalytic amounts of $\text{Pd}(\text{OAc})_2$ and DPPP under the conditions developed for the carbonylation of acyclic allyl sulfides (see Chapter 5) but only the starting material remained. If the temperature was increased above $150\text{ }^\circ\text{C}$, metallic palladium precipitated, and no carbonylation was observed. A carbonylation was also attempted using stoichiometric amounts of palladium acetate and DPPP. Again only the starting material was present by TLC analysis of the crude reaction mixture (equation 114).

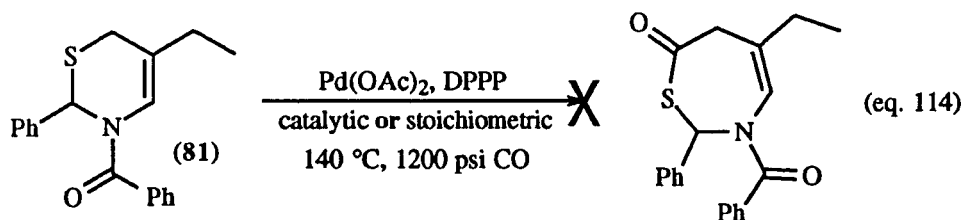

Finally, the carbonylative ring expansion of compound **81** was attempted using ruthenium carbonyl. When the carbonylation was attempted at $150\text{ }^\circ\text{C}$ under 1000 psi of CO, the starting material was recovered unchanged. There was also no reaction using a stoichiometric amount of $\text{Ru}_3(\text{CO})_{12}$ but if the reaction was run at $180\text{ }^\circ\text{C}$, a very small amount (ca. 5%) of a carbonyl containing compound which, we believe, resulted from insertion of carbon monoxide into the C–S bond of the thiazine ring was observed. Small amounts of this material (3–5 mg) could be isolated and the ^{13}C NMR spectra displayed a signal at 189 ppm, which is indicative of a thioester (equation 115). The low yield of the compound and the small scales employed prevented a more detailed characterization of this

material. Stoichiometric amounts of $\text{Ru}_3(\text{CO})_{12}$ did not improve the yield. Thus, although it appears that carbonylation has indeed been affected, the yield is very low and the structure of the carbonylated material could not be confirmed.

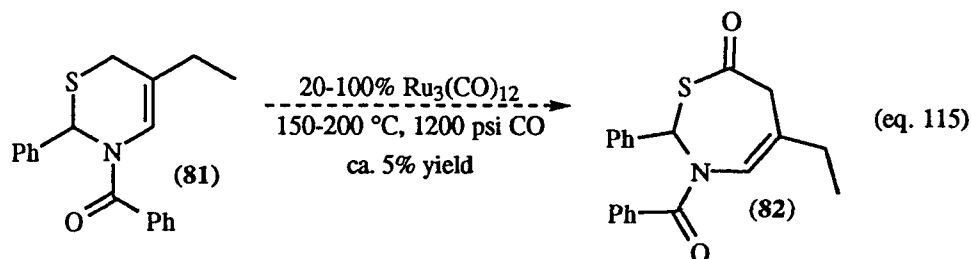

4.3 Conclusions

In conclusion, we have demonstrated that the carbonylation of six membered ring heterocycles is extremely challenging. However, under forcing conditions, two heterocyclic systems appear to be susceptible to this carbonylation reaction. The simple tetrahydroquinoline series discussed at the beginning of this chapter gave three new products which contain carbon monoxide, *according to mass spectral analysis*. However, since isolation of the products and determination of their structures was not possible, we cannot be sure that carbonylation indeed took place. Of the many catalytic systems we examined, only two were active for the carbonylation, namely $\text{Co}_2(\text{CO})_8 / \text{Ru}_3(\text{CO})_{12}$ and $[\text{Pd}(\text{CH}_3\text{CN})_4^{2+}] (\text{BF}_4^-)_2 / \text{CuCl}_2$. In certain experiments using the Pd/Cu system, δ -valerolactone, resulting from the carbonylation of THF, was observed.

Dihydrothiazines were prepared in 6 steps and a small amount of carbonylated material was obtained when they were subjected to $\text{Ru}_3(\text{CO})_{12}$ at elevated temperatures under CO pressure. Purification by preparative TLC allowed us to isolate small quantities of this carbonylated material which contained a reasonably strong resonance at 189 ppm in

its ^{13}C NMR spectrum. The use of stoichiometric amounts of ruthenium carbonyl or extended reaction times did not improve the yield.

Although the carbonylative ring expansion of a six membered ring would be an extremely useful method for the synthesis of caprolactones and caprolactams, we have not been able to develop conditions to affect this carbonylation in reasonable yield despite trying eight different heterocyclic systems and numerous catalytic systems employing Rh, Pd, Cu, Co, Ru and combinations of these complexes.

Chapter 5: Carbonylation of Allyl Aryl and Allyl Alkyl Sulfides with Palladium and Ruthenium Catalysts.

5.1 Introduction

This chapter will describe our research into the carbonylation of allyl aryl and allyl alkyl sulfides. Although the direct carbonylation of C–N and C–O bonds in allylic systems has been described, there have been no reports of the carbonylation of acyclic C–S bonds. We found the carbonylation to be reasonably facile, and general. Palladium catalysts yielded the product of isomerization of the double bond into conjugation with the thioester and ruthenium complexes gave the unconjugated product.

5.1.1 Carbonylation of π -Allylic Substrates.

As noted in the general introduction, (1.2.3.3), the palladium catalyzed carbonylation of allylic halides is reasonably facile, while the carbonylation of allylic oxygen and nitrogen compounds requires more severe conditions.^{56,57} A number of techniques have been described to effect the carbonylation of these substrates, and research continues into further improving the mildness and selectivity of the carbonylation of allylic halides.^{132a}

One very valuable technique for synthesizing 2- or 3-butenic acids from allyl bromide employs phase transfer catalysis. In 1985, Alper and Joo^{132b} reported the Ni(CN)₂ catalyzed carbonylation of a variety of allylic bromides. This system is very useful for several reasons. It employs an inexpensive nickel complex as the catalyst, the conditions required for the reaction are very mild, (1 atmosphere, room temperature), the

isolated yields are high and the 2- or the 3- isomer can be obtained in greater than 90% selectivity by simply modifying the base concentration (Scheme 19).

Scheme 19: Nickel Catalyzed Carbonylation of Allylbromide

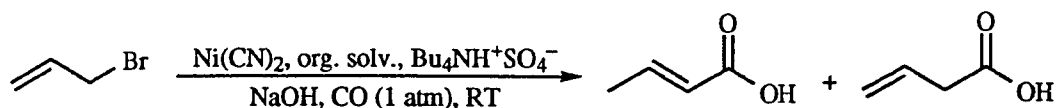

org. solv. = 4-methyl-2-pentanone 1 M NaOH, 59% isolated yield	0	:	100
org. solv. = 4-methyl-2-pentanone 1.5 M NaOH, 86% isolated yield	7	:	93
org. solv. = toluene 5 M NaOH, 90% isolated yield	93	:	7

A number of methods have been reported recently for the carbonylation of allyl alcohol derivatives. The most popular is derivatising the alcohol before carbonylation, for example as its phosphate or carbonate^{57, 58}, but acetates are also important substrates. Murahashi reported a reasonably mild method for the carbonylation of allyl acetates in 1993.⁵⁷ Allyl acetates are poor substrates for carbonylation because oxidative addition leading to intermediate **83** is reversible, and because the back reaction is favoured in the presence of CO. Yamamoto et al.¹³³ isolated an allylpalladium acetate complex (**83**, $L_n = PCy_3$, Scheme 20) and treated it with 1 atm of CO at room temperature for 24 hours. Under these mild conditions, **83** undergoes reductive elimination regenerating allyl acetate and producing several palladium carbonyl species $[Pd(PCy_3)_m(CO)_n]$.

Murahashi reported that by simply adding bromide ion to the catalytic system, the problem of reductive elimination of the allyl and acetato ligands could be solved presumably by the generation of intermediates of type **84** (Scheme 20).⁵⁷ This represents a mild and effective method for the carbonylation of allylic acetates.

Scheme 20: Palladium Catalyzed Carbonylation of Allylacetate

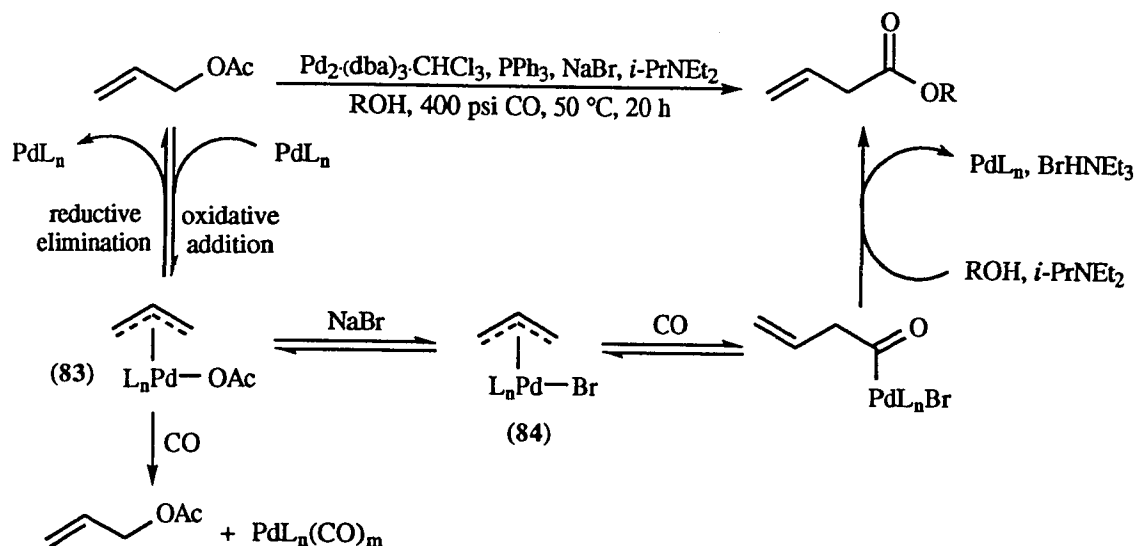

In the carbonate case, the reaction also proceeds under mild conditions, and the addition of an external nucleophile is not necessary, rather *in situ* decarboxylation of the $-\text{CO}_2\text{R}$ generates the nucleophile (see equation 33, Chapter 1 and equation 116).⁵⁸ Although this reaction occurs under very mild conditions, it suffers from premature attack on the π -allyl intermediate resulting in contamination of the allyl ester product with allyl ether.

A similar approach has been developed by Yamamoto et al. for the synthesis of amides from carbamates (equation 117).¹³⁴ As was previously discussed, Tsuji demonstrated that a decarboxylation/carbonylation sequence can be very useful for the mild carbonylation of allyl alcohol derivatives. In this system, allyl ether contamination was a problem, and allylamine formation is also a complication of the Yamamoto allyl carbamate method (equation 116 and 117).

Tsuji:

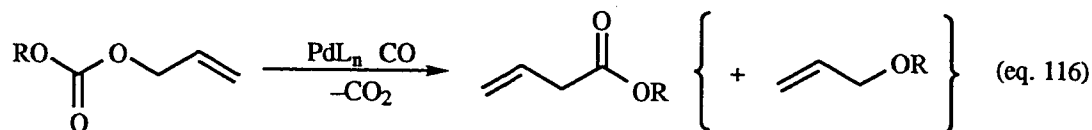

Yamamoto:

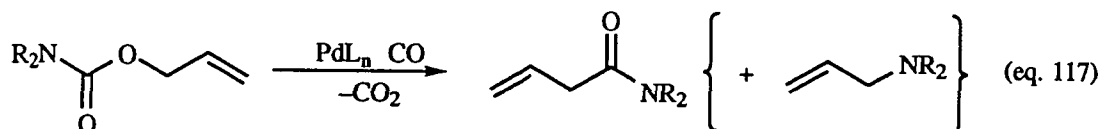

If one is not limited by the use of an allyl alcohol derivative, the carbonylation of allylic halides in the presence of an alcohol added as the external nucleophile is a very useful method for the synthesis of esters. Theoretically an amine could be used instead of an alcohol. The product of this reaction would be the same as if the direct carbonylation of an allylamine had been effected. Unfortunately, amine nucleophiles cannot be used in the carbonylation of π -allyl systems because the increased nucleophilicity of the amine leads to premature attack on the π -allyl intermediate before carbonylation giving allylamines instead of amides from this reaction (equation 118).

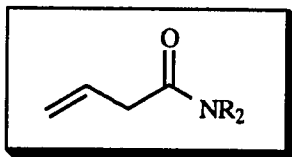
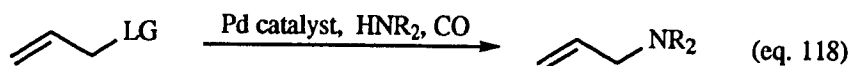

Not formed

Thus the direct carbonylation of simple allylamines is an important method for the synthesis of allyl amides using carbonylation techniques. Murahashi has developed conditions for the direct carbonylation of a variety of allylamines yielding β , γ -unsaturated amides.¹³⁵ Since allylamines are the starting substrates for this reaction, the problem of premature attack (or reductive elimination) is circumvented. For simplicity,

the σ -allyl carbonylation mechanism is shown, but the carbomethoxy (or in this case the carboamido) mechanism cannot be discounted.

Scheme 21: Palladium Catalyzed Carbonylation of Allylamine

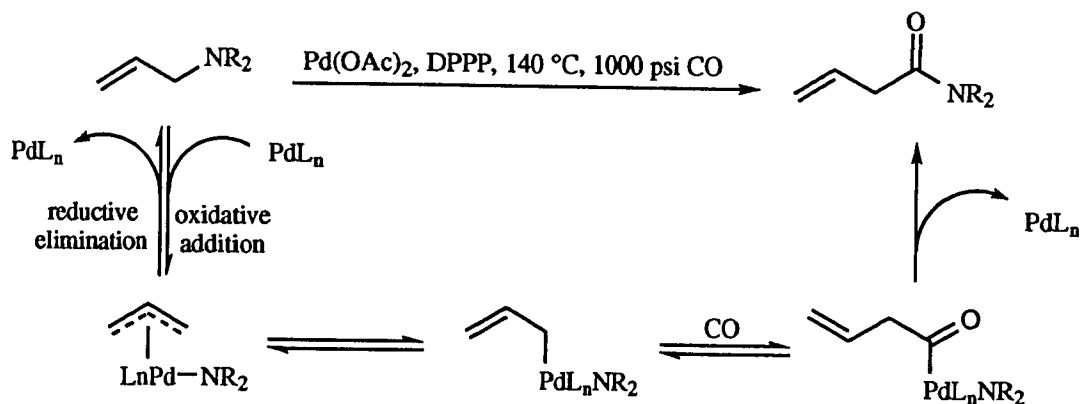

Although a variety of nucleophiles can be reacted with π -allylpalladium intermediates, either with or without carbon monoxide, the attempted synthesis of allyl sulfides by the palladium catalyzed reaction of allylic halides or other allyl derivatives with sulfur nucleophiles is problematic because the addition of stoichiometric amounts of sulfur nucleophiles is known to irreversibly inactivate the palladium catalyst.¹³⁶ For this reason there have been only scattered reports of palladium catalyzed allylation of sulfur nucleophiles, and one of the more elegant approaches was published by Bosnich et al.¹³⁷ They reported a palladium catalyzed method for the preparation of allyl sulfides using *O*-allyl thiocarbonates. The key to the success of this method is that the sulfur nucleophile is generated only as quickly as it is needed. The proposed mechanism is shown in equation 119.

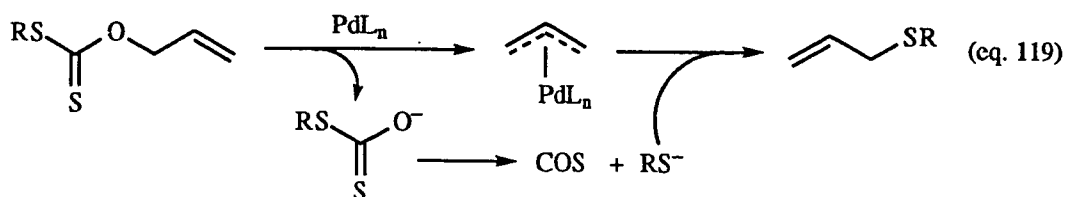

The synthesis of allyl thioesters from the carbonylation of allyl thiocarbonates using this system or directly from allyl sulfides has never been reported, and as part of our study into the carbonylation of six membered ring sulfur containing heterocycles (see Chapter 4 section 4.2.5), we studied a variety of allyl sulfides. The results of these studies will be described in this chapter.

5.2 Results and Discussion

As a model substrate, we chose allyl 4-methylphenyl sulfide and examined its reaction with stoichiometric and catalytic amounts of a variety of metal complexes. The first system we studied was the same one employed in Murahashi's allylamine carbonylation, namely palladium acetate and 1,3-bis(diphenylphosphino)propane (1 : 2) in toluene at 140°C for 24 hours. Under these conditions we obtained virtually no reaction and therefore turned our attention to other systems.

Although Pd(OAc)₂/DPPP did not catalyze the carbonylation, tetrakis-(triphenylphosphine)palladium was an effective catalyst, with allyl 4-methylphenyl sulfide being converted to the corresponding thioester by insertion of CO into the S-allyl bond. The carbonylation was accompanied by isomerization of the expected β, γ-thioester to the α, β-thioester (85) as shown in equation 120. It was obvious from the coupling constants for the olefinic protons in the ¹H NMR spectrum that only the *trans* isomer had been produced (>95%). A spectrum of (E)-2-butenyl (4-methylbenzene)

thiolate (**85**) obtained from the carbonylation of allyl 4-methylphenyl sulfide is shown in Figure 11.

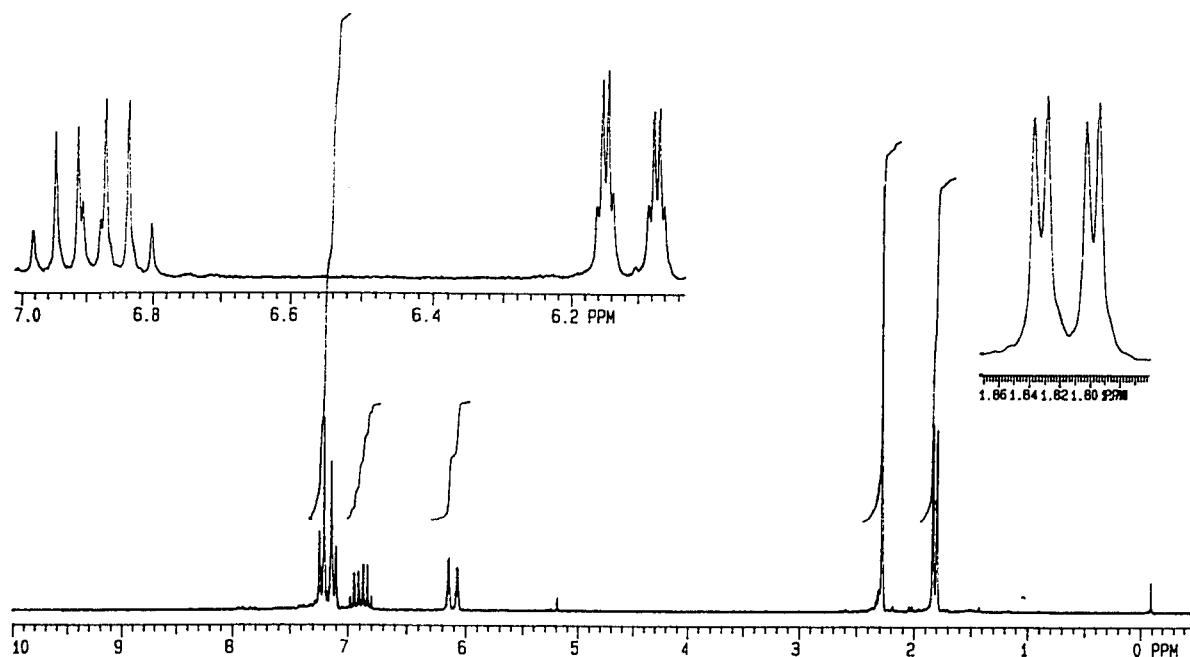
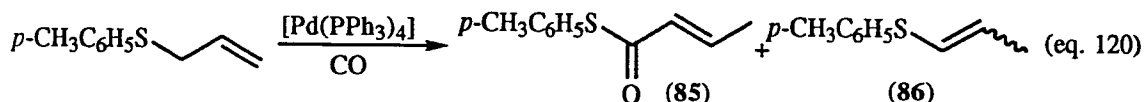

Figure 11: ^1H NMR Spectrum of (E)-2-Butenoic acid S-(4-methylphenyl) ester (**85**).

Analysis of the crude reaction mixture by ^1H NMR indicated that along with thioester **85**, a second olefinic product was produced. This material was shown to be vinyl sulfide **86** resulting from isomerization of the olefin in allyl 4-methylphenyl sulfide.¹³⁸ Optimization of the carbonylation reaction is shown in Table 15.

Table 15: Carbonylation of Allyl 4-Methylphenyl Sulfide with [Pd(PPh₃)₄]^a



Entry	Time (h)	Temp (°C)	Solvent	Conv. (%) ^{b,c}	Yield (%) ^b	Enol Sulfide (%) ^b
1	44	140	Toluene	75	53	19
2	44	140	THF	84	46	30
3	72	140	Toluene	91	62	26
4	100	100	Toluene	100	64	11
5 ^d	72	140	Toluene	96	61	6

^aReaction conditions unless otherwise noted: 0.33–1.07 mmol substrate, 3–4 mL solvent, 20% [Pd(PPh₃)₄], 1000 psi CO. Yields and conversions determined by ¹H NMR are ±5%. ^bDetermined by ¹H NMR vs. added internal standard (Ph₂CH₂). ^cConv. = Conversion. ^d10% catalyst used.

The first reactions with [Pd(PPh₃)₄] were performed at 140 °C under 1000 psi of carbon monoxide for 48 hours. Toluene was found to be more effective than THF for this reaction giving a slightly higher yield and less isomerization of the starting material (19% compared with 30%).

When the reaction was run for 72 instead of 44 h, 62% of the desired thioester could be obtained, but 26% of the isomerized product was also observed. If the temperature was decreased and the reaction run for 100 hours, less isomerization (11%) was observed and the yield of the carbonylated product remained the same (Table 15, entry 4). It was also found that when the amount of catalyst used was decreased from 20 to 10%, and the reaction run for 72 hours, only 6% of the starting material was lost to isomerization, and the yield of the desired product was virtually the same as in the other systems (compare entries 3 and 5 in Table 15).

Table 16: Carbonylation of Allyl 4-Methylphenyl Sulfide with Palladium Acetate^a

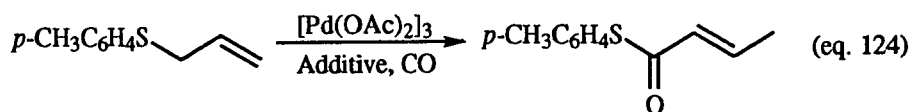

Entry	Catalytic System	Conversion (%) ^b	Yield (%) ^b	Yield of 86 (%) ^b
1	Pd(OAc) ₂ : DPPP (1:1)	87	73 (50) ^c	0
2	Pd(OAc) ₂ : DPPP (1:2)	NR	—	—
3	Pd(OAc) ₂ : PPh ₃ (1:2)	56	44	0
4	Pd(OAc) ₂ : PCy ₃ (1:2)	NR	—	—
5	Pd(OAc) ₂ : NaOAc (1:5)	NR	—	—
6	Pd(OAc) ₂ (alone)	NR	—	—

^aReaction conditions unless otherwise noted: 1.05–1.24 mmol substrate, 4 mL solvent, 10% palladium complex, 1000 psi CO. Yields and conversions determined by ¹H NMR are ±5%. ^bDetermined by ¹H NMR vs. added internal standard (Ph₂CH₂). ^cIsolated yield.

As previously noted, the use of two equivalents of DPPP suppressed the carbonylation reaction (compare entries 1 and 2). Without any phosphine, there was also no reaction (entry 5). The reaction proceeded in the presence of two equivalents of triphenylphosphine, although both the yield and the conversion were lower than in the DPPP experiment (entry 3). The combination of tricyclohexylphosphine and Pd(OAc)₂ was completely ineffective (see entry 4). Finally, we attempted the carbonylation reaction in the presence of 5 equivalents (per Pd) of sodium acetate, since it was shown by Milstein that the presence of such carboxylate salts enhances the stoichiometric carbonylation of π-allylpalladium complexes.¹⁴⁰ In our system, however, we observed no carbonylation under these conditions, and the starting allyl sulfide remained unchanged.

We also examined other metal complexes known to be effective for the carbonylation of sulfides. As described in Chapter 4, $[\text{Rh}(\text{COD})\text{Cl}]_2$ was shown to be a useful catalyst for the carbonylation of cyclic and acyclic 1,3-*N,S* systems⁵⁵ but no reaction was observed when allyl 4-methylphenyl sulfide was exposed to CO in the presence of this complex. A cationic palladium complex containing a DPPP ligand, $[\text{Pd}(\text{BN})_2(\text{DPPP})]^{2+}(\text{BF}_4^-)_2$, was not effective. Some nickel complexes which were known to catalyze the cross coupling of allyl sulfides and Grignard reagents¹⁴¹, namely $\text{Ni}(\text{PPh}_3)_2(\text{CO})_2$ and $\text{NiCl}_2(\text{DPPE})_2$ did not promote the carbonylation even when stoichiometric amounts were used. Molybdenum carbonyl, which is known to form π -allyl complexes and to desulfurize organic sulfides did not affect any reaction.¹⁴² Finally, it was found that a mixture of dicobalt octacarbonyl and ruthenium carbonyl which were previously used in the carbonylation of thietanes^{143,53b} gave a low yield (7%) of the *unconjugated* allyl thioester (**87**) by NMR analysis of the crude reaction mixture.

Although the yield was low, the selectivity of the carbonylation was good with only the β , γ -isomer being detected in the ^1H NMR of the crude reaction mixture. We, therefore, examined a variety of ruthenium complexes alone, or in combination with iridium complexes. Selected results are shown in Table 17. Varying the ruthenium and iridium complexes lead to the discovery of the moderately successful combination of $\text{Ru}_3(\text{CO})_{12}$ and $\text{Ir}_4(\text{CO})_{12}$, which catalyzed the carbonylation of allyl 4-methylphenyl sulfide to yield the *unconjugated* thioester (**87**) in moderate to low yields. Subsequent experiments demonstrated that better results were obtained when $\text{Ru}_3(\text{CO})_{12}$ was used alone, but the results will be described in chronological order.

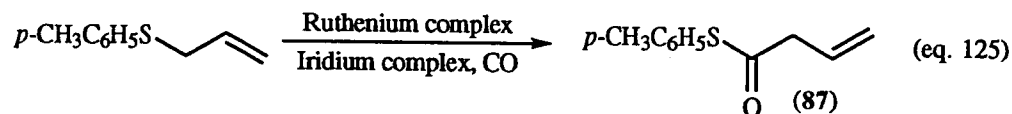
Table 17: Carbonylation with Ruthenium and Iridium Complexes^a

Entry	Catalyst	Co-Catalyst	Time (h)	Conversion (%) ^b	Yield (%) ^b
1	RuCl ₂ (PPh ₃) ₃	Ir(COD)Cl	42	12	7
2	RuCl ₂ (PPh ₃) ₃	Ir(CO) ₃ Cl	42	20	16
3	Ru ₃ (CO) ₁₂	Ir(CO) ₃ Cl	60	51	0
4	Ru ₃ (CO) ₁₂ ^c	Ir ₄ (CO) ₁₂	60	55	23
5	Ru ₃ (CO) ₁₂	Ir ₄ (CO) ₁₂	45	30	18
6	RuCl ₂ (PPh ₃) ₃ ^d	Ir ₄ (CO) ₁₂	45	2	0
7	Ru ₃ (CO) ₁₂ ^c	Ir ₄ (CO) ₁₂	65	55	34
8	Ru ₃ (CO) ₁₂	IrCl(CO)(PPh ₃) ₂	45	35	0
9	Ru ₃ (CO) ₁₂ ^e	Ir ₄ (CO) ₁₂	69	65	24
10	RuCl ₂ (PPh ₃) ₃	Ir(CO) ₃ Cl	69	36	27
11	Ru ₃ (CO) ₁₂	none	45	47	34
12	Ir ₄ (CO) ₁₂	none	45	7	0
13	Ru ₃ (CO) ₁₂	none	72	65	50
14	Ru ₃ (CO) ₁₂	NaOAc ^f	24	66	0 ^g
15	RuCl ₂ (PPh ₃) ₃	none	72	-	0

^aReaction conditions unless otherwise noted: ca. 1 mmol substrate, 4 mL toluene, 0.1 mmol ruthenium complex, 0.1 mmol of co-catalyst if required, 1000 psi CO, 140 °C. Yields and conversions determined by ¹H NMR are ±5%. ^bDetermined by ¹H NMR vs. added internal standard (Ph₂CH₂). ^c100 °C. ^d120 °C. ^eTHF as solvent. ^fFive equivalents of NaOAc (per Ru) were used. ^gThe enol thioether (86) was observed in this experiment (17%).

As can be seen from Table 17, RuCl₂(PPh₃)₃ used in combination with either [Ir(COD)Cl]₂, Ir(CO)₃Cl, or Ir₄(CO)₁₂ was less effective than Ru₃(CO)₁₂ and Ir₄(CO)₁₂.

In the best case, $\text{RuCl}_2(\text{PPh}_3)_3$ and $\text{Ir}(\text{CO})_3\text{Cl}$ gave 27% yield and 36% conversion after 69 hours. This gives a turnover number on the order of one per day.

Although a 1:1 mixture of $\text{Ru}_3(\text{CO})_{12}$ and $\text{Ir}_4(\text{CO})_{12}$ proved to be the most effective mixed system, each of these complexes failed to catalyze the carbonylation when mixed with other ruthenium or iridium complexes which implied a co-operative effect. For example, no carbonylation was observed when ruthenium carbonyl was used with iridium chloro carbonyl or Vaska's complex (see entries 3 and 8). Similarly, the combination of iridium carbonyl and $\text{RuCl}_2(\text{PPh}_3)_3$ gave only 2% conversion and no detectable product after 45 hours at 120°C (entry 6). Thus it appeared to us that both $\text{Ru}_3(\text{CO})_{12}$ and $\text{Ir}_4(\text{CO})_{12}$ were necessary for the carbonylation. This assumption was incorrect, however, since it was subsequently shown that $\text{Ru}_3(\text{CO})_{12}$ alone catalyzed the carbonylation while $\text{Ir}_4(\text{CO})_{12}$ did not (see entries 11 and 12 in Table 17).

This result was surprising since $\text{Ru}_3(\text{CO})_{12}$ was a poor catalyst in combination with other iridium complexes (entries 3 and 8). It is possible that the formation of mixed metal clusters in some of the examples destroyed or at least hindered the ability of the ruthenium to catalyze the reaction. The fact that a mixture of dicobalt octacarbonyl and $\text{Ru}_3(\text{CO})_{12}$ gave only a low yield (7%) supports this postulation.

Although the carbonylation is slow, if the reaction is left for 3 days, 50% yield and 65% conversion are obtained. The carbonylation is clean with only the allyl thio-ester detectable in the crude ^1H NMR. Therefore, the crude reaction mixture can be easily analyzed by addition of an internal standard (Ph_2CH_2) and removal of the toluene *in vacuo*. When 5 equivalents (per Ru) of NaOAc were added, none of the carbonylated product was observed, instead 17% of the enol thioether was observed in the ^1H NMR spectrum of the crude reaction mixture (Table 17, entry 14).

The ruthenium system was a good complement to the palladium catalyzed carbonylations described in Table 16 since the β , γ -unsaturated thioesters are obtained

exclusively. On standing, especially in an NMR tube, small amounts of the α , β -isomer could be detected.

The scope of the ruthenium and palladium catalyzed carbonylation reactions was examined using a variety of allyl alkyl and allyl aryl sulfides as shown in Tables 18 and 19.

From Table 18 it can be seen that the yields and conversions are consistently lower with the ruthenium system. In the palladium catalyzed carbonylation reactions, the yields of the thioesters were virtually the same for all the aryl substrates examined thus far except for *p*-fluorophenyl allyl sulfide. In this case, a considerably lower yield of the carbonylated product (**92**) was obtained (39%, entry 8). For the ruthenium catalyzed carbonylation reactions, the yields were also virtually insensitive to the electronic nature of the aromatic group. The 4-methylphenyl sulfide gave the best yield of 50% (entry 4), but this is not a dramatic difference from the lowest yield (33% for phenyl allyl sulfide, entry 2).



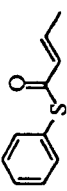
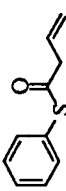
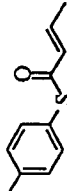
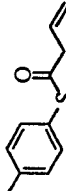
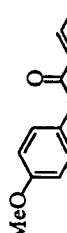
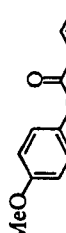
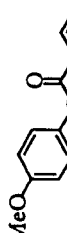
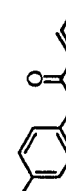
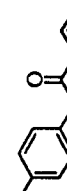

The alkyl allyl sulfides examined in this study are shown in Table 19. As in the aryl series, the palladium acetate/DPPP system catalyzed the carbonylation of the allyl sulfides to yield the α , β -thioesters specifically. The yields in these systems were good, with almost 100% conversion being obtained in 45 hours for both the *s*-butyl and *n*-hexyl substrates. The NMR yields of the desired products were 88 and 86% for the *n*-hexyl and *s*-butyl cases (see entries 1 and 5 of Table 19). Since 100% conversion was observed under these conditions, the reactions were repeated and stopped after 25 hours. Although the reactions were not complete, ca. 50% of the desired products were isolated (entries 2 and 6). These results and others are compiled in Table 19.

Table 18: Palladium and Ruthenium Catalyzed Carbonylation of Substituted Allyl Aryl Sulfides ^a

Entry	Ar	Catalyst System	Product	Compound No.	Conv. (%) ^b	Yield (%) ^{b, c}
1	phenyl	Pd(OAc) ₂ /DPPP		(88)	92	69
2	phenyl	Ru ₃ (CO) ₁₂		(89)	55	33 (30)
3	<i>p</i> -tolyl	Pd(OAc) ₂ /DPPP		(85)	87	73
4	<i>p</i> -tolyl	Ru ₃ (CO) ₁₂		(87)	65	50
5	<i>p</i> -anisole	Pd(OAc) ₂ /DPPP		(90)	—	(62)
6	<i>p</i> -anisole	Ru ₃ (CO) ₁₂		(91)	—	(37)
7	<i>p</i> -anisole ^d	Ru ₃ (CO) ₁₂		(91)	—	(39) ^d
8	<i>p</i> -fluorophenyl	Pd(OAc) ₂ /DPPP		(92)	74	39
9	<i>p</i> -fluorophenyl	Ru ₃ (CO) ₁₂		(93)	60	35 (32)

^aReaction conditions unless otherwise noted: 1.99-0.94 mmol substrate, 4-8 mL toluene, 10% metal complex, 10% mmol of phosphine if required, 1000 psi CO, 140 °C. ^bDetermined by ¹H NMR vs. added internal standard (Ph₂CH₂). ^cIsolated yields given in parentheses. ^dThis reaction was run at 120 °C.

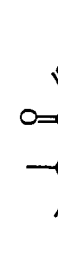
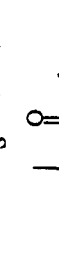
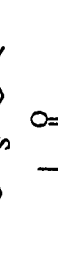
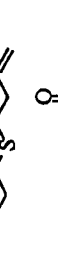
Table 19: Palladium and Ruthenium Catalyzed Carbonylation of Substituted Allyl Alkyl Sulfides ^a

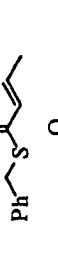
Entry	R	Catalyst System	Time (h)	Product	Compound No.	Conv. (%) ^b	Yield (%) ^{b, c}
1	<i>n</i> -hexyl	Pd(OAc) ₂ /DPPP	45		(94)	92	69
2	<i>n</i> -hexyl	Pd(OAc) ₂ /DPPP	24		(94)	65	45 (46)
3	<i>n</i> -hexyl	Ru ₃ (CO) ₁₂	72		(95)	58	24
4	<i>s</i> -butyl	Pd(OAc) ₂ /DPPP	45		(96)	100	86
5	<i>s</i> -butyl	Pd(OAc) ₂ /DPPP	24		(96)	87	51 (49)
6	<i>s</i> -butyl	Ru ₃ (CO) ₁₂	72		(97)	65	14
7	<i>n</i> -dodecyl	Pd(OAc) ₂ /DPPP	65		(98)	82	66 (59)
8	<i>n</i> -dodecyl	Ru ₃ (CO) ₁₂	72		(99)	55	24
9	benzyl	Pd(OAc) ₂ /DPPP	44		(100)	59	43
10	benzyl	Ru ₃ (CO) ₁₂	72		(101)	72	50 (40)

^aReaction conditions unless otherwise noted: 1.99-0.94 mmol substrate, 4-8 mL toluene, 10% metal complex, 10% mmol of phosphine if required, 1000 psi CO, 140 °C. ^bDetermined by ¹H NMR vs. added internal standard (Ph₂CH₂). ^c Isolated yields given in parentheses.

In the reaction of allyl *n*-dodecyl sulfide, 66% NMR yield (59% isolated) was obtained after 65 hours. Allyl benzyl sulfide gave only a moderate amount of the desired thioester (43% yield, 59% conversion, entry 9) after 44 hours.

The ruthenium system gave much lower yields with the alkyl sulfides (14–24%) which further illustrates the difference between the ruthenium and palladium systems. Allyl benzyl sulfide was an exception to this trend since it gave 50% of the desired thioester by NMR (40% isolated) (entry 10).

Another alkyl substrate that was examined in the reaction was benzyl (2-methyl-2-propenyl) sulfide (**102**) which affords low yields of the carbonylated products in both the ruthenium and palladium catalyzed reactions as shown in equations 126 and 127. Comparison of these yields with the results obtained in the simple benzyl allyl sulfide system (entries 9 and 10) shows that substitution in the 2-position of the allyl moiety decreases the yields of both the α , β - and β , γ -unsaturated thioesters. Thus the reaction of benzyl (2-methyl-2-propenyl) sulfide gave 22% yield of the desired α , β -thioester while simple allyl benzyl sulfide yielded 43% of the same compound under identical conditions. The ruthenium reaction was also sensitive to steric effects giving only 27% of the β , γ -thioester vs 50% for the carbonylation of allyl benzyl sulfide.

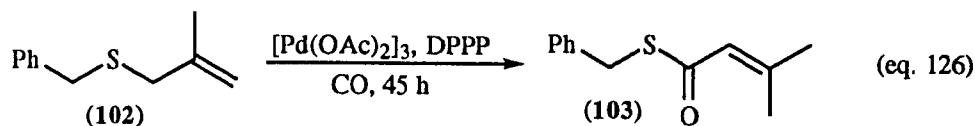

30% conversion, 22% yield

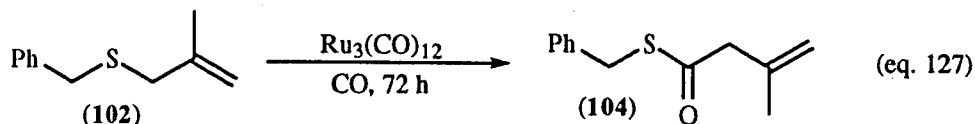

53% conversion, 27% yield
24% isolated yield

In order to confirm the π -allyl nature of the reaction, 2-butenyl and 3-(1-butenyl) phenyl sulfide were synthesized via the same method used in the preparation of the substituted aryl allyl sulfides. Thus deprotonation of thiophenol with sodium methoxide in methanol, followed by treatment with 1-bromo-2-butene (E/Z = 70/30) gave compound **105** in 58% yield.¹⁴⁴ Similarly, PhSNa was treated with 3-bromobutene affording a mixture of the two allyl sulfides in which the desired isomer (**106**) was predominant (65/35). These results are shown in equations 128 and 129.

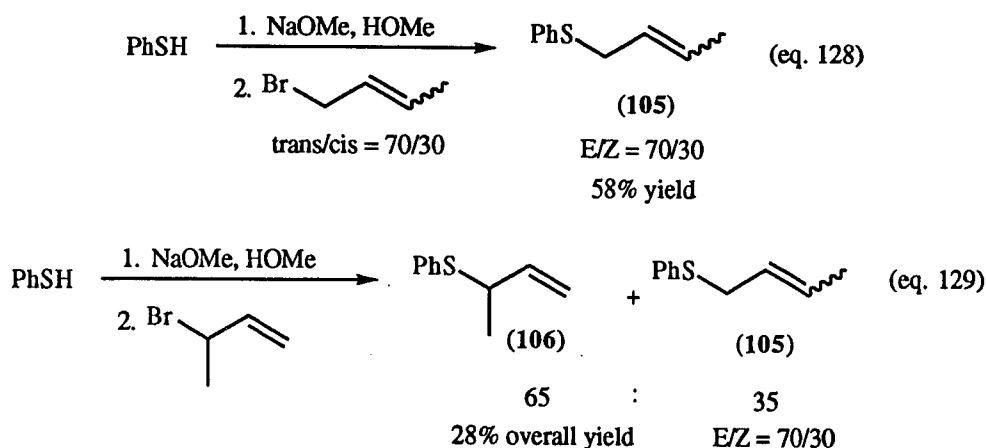

As expected, both substrates yielded the same product, resulting from carbonylation at the least hindered site when they were treated with Pd(OAc)₂, DPPP and CO according to the general procedure. The crude spectra of the two experiments were virtually identical. The exact conversions and yields are given in equations 130 and 131, and are the same within experimental error.

Scheme 22: Palladium Catalyzed Carbonylation of 3-(1-Butenyl) Phenyl Sulfide.

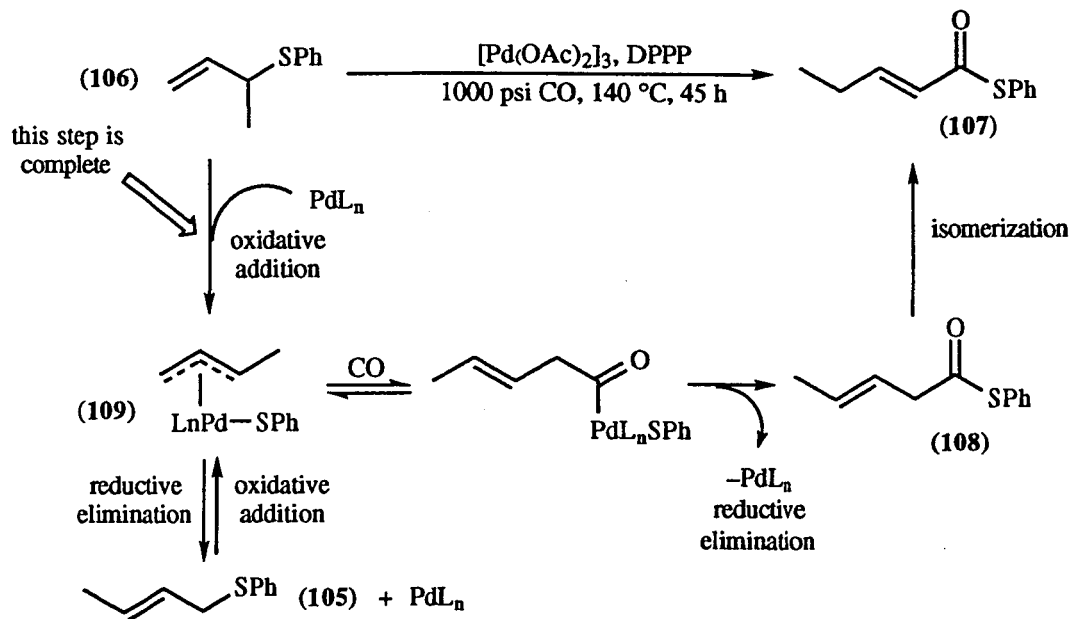

A similar experiment was performed in the ruthenium system, but the results were difficult to interpret due to the very low yields obtained in the carbonylation of both compounds **105** and **106**.

5.3 Conclusions

We have established that a variety of aryl allyl and alkyl allyl sulfides can be carbonylated to yield the corresponding thioesters in poor to excellent yields depending on the nature of the substrate. The carbonylation reaction is catalyzed by both palladium and ruthenium systems, and it was found that these two metals give complementary results. With the palladium system, the initially formed β,γ -unsaturated thioester underwent complete isomerization yielding the α,β -unsaturated thioester (100% *trans*).

The ruthenium system, on the other hand, afforded the β , γ -unsaturated thioester without concomitant isomerization.

In general, the yields were higher with the palladium than the ruthenium system, and this effect is most pronounced in the alkyl allyl series. For these substrates, >85% yield and 100% conversion could be obtained in the palladium catalyzed reactions, but the yields were very low when the alkyl allyl sulfides were treated with ruthenium carbonyl under the standard conditions.

The reactions were usually very clean, with only the product and unreacted starting material detected in the crude NMR of the reaction mixture. In those reactions catalyzed by $[\text{Pd}(\text{PPh}_3)_4]$, some isomerization of the starting allyl sulfide to the thio enol ether was observed. It was subsequently found that palladium acetate and DPPP was a more effective system than $[\text{Pd}(\text{PPh}_3)_4]$, so this isomerization was not problematic. None of the isomerization product (**86**) was observed in the ruthenium catalyzed reaction, except in the presence of NaOAc.

The carbonylation reaction was shown to be sensitive to steric hindrance on the allyl moiety. Thus the palladium and ruthenium catalyzed carbonylation reactions of benzyl (2-methyl-2-propenyl) sulfide gave less than half the yield of the thioester compared to the reaction of simple allyl benzyl sulfide under identical conditions. Although both systems are sensitive to steric hindrance, the conversions usually parallel the yields so it should be possible to obtain higher yields at longer reaction times. Furthermore, the yields were not optimized for each substrate, and modification of the procedure developed for the carbonylation of allyl 4-methylphenyl sulfide might give higher yields for individual substrates.

The palladium and ruthenium catalyzed carbonylation reactions described herein represent the first example (to the best of our knowledge) of the insertion of carbon monoxide into the carbon-sulfur bond of allyl sulfides.

Chapter 6: Experimental

6.1 General Experimental

All ^1H NMR and ^{13}C NMR spectra were recorded on a Varian 200 or 300 MHz Gemini instrument operating at 200 and 300 MHz for ^1H and 50 and 75 MHz for ^{13}C , respectively. NMR data are reported in chemical shift relative to tetramethylsilane as the internal standard, multiplicity (s=singlet, d=doublet, t=triplet, q=quartet, b=broad and m=multiplet), integration and assignment. NMR spectra were run in CDCl_3 containing 0.03% TMS or in C_6D_6 . Proton spectra were referenced to 7.24 ppm for CDCl_3 or 7.16 ppm for C_6D_6 and carbon to 77.0 ppm for CDCl_3 or 128.0 ppm for C_6H_6 . Infrared data were collected on a Bomem MB-100 FT-IR spectrometer. Liquid samples were run neat using sodium chloride disks. Solid samples were analyzed using fabricated KBr disks. Gas chromatographic analyses were performed on a Varian 3300 using a DB1 capillary column and a Varian 4270 integrator.

All air and/or moisture sensitive reactions were performed in glassware flame dried under a purge of dry nitrogen (passed through a drierite tower), or flame dried under vacuum followed by flushing with nitrogen. Solvents, solutions, and liquid reagents were transferred with syringes and double ended needles (cannulae) using standard inert atmosphere techniques. Liquid substrates or reagents for small scale reactions were weighed. Air sensitive solids were handled using standard Schlenk techniques and transferred using a glove bag.

Chromatographic purifications were performed using flash grade silica gel and low pressure was applied to the top of the column using a hand pump. Except for large scale reactions, samples were dissolved in dichloromethane and silica gel added. The volatiles were removed *in vacuo* and the resulting solid pumped on for 5 minutes at high vacuum to remove most of the dichloromethane. The solid was then added to the top of

the prepacked column. HPLC purifications were performed using a JAI recycling semi-prep HPLC and columns packed JAIGEL (polystyrene). CHCl_3 was used as the eluant and an RI detector used to observe the peaks. An Aldrich brand Kugelrohr was used for small scale distillations and sublimations. GC yields are all reported vs internal standard, and calibration curves were made up for the detector response to vinyltriethylsilane, tetraethylsilane, propanal triethylsilyl enol ether and triethylsilylpropanal.

Solvents were dried using the drying agents listed and distilled under a dry atmosphere: benzene, anisole, diethyl ether and tetrahydrofuran from sodium metal/benzophenone ketyl over nitrogen; chloroform, and α, α, α -trifluorotoluene from P_2O_5 ; dichloromethane, toluene and triethylamine from calcium hydride under drierite in air; methanol from $\text{Mg}(\text{OMe})_2$ under nitrogen; propanal from MgSO_4 under nitrogen. Bromoacetophenone was purified by sublimation at reduced pressure using a Kugelrohr apparatus. Vinyl silanes were used as purchased from Aldrich, Lancaster or Fluka Chemical Companies, or older samples were purified by passing through a small plug of neutral alumina. d_6 -Benzene and CDCl_3 were also purified by passing through a plug of neutral or basic alumina prior to reaction. $\text{Rh}(\text{COD})\text{BPh}_4$, $[\text{Co}_3(\eta^6\text{-C}_6\text{H}_6)_3(\mu_3\text{-CO})_2]\text{BPh}_4$ and $[\text{Rh}(\text{COD})_2]^+\text{BF}_4^-$ were synthesized according to the literature (see references 18b, 85 and 114 respectively). Commercially available $[\text{Rh}(\text{COD})_2]^+\text{BF}_4^-$ gave identical results. We thank Dr. Ibrahim Amer and Dr. Yuri Goldberg for the preparation of $\text{Ir}(\text{COD})\text{BPh}_4$ and $[\text{Ir}(\text{COD})\text{Cl}]_2$, respectively. Carbon monoxide, UHP hydrogen and carbon dioxide were supplied by Air Products.

The following chemicals were used as purchased or, after purification (*vide supra*), from the following suppliers: *meta*-dimethoxybenzene and propanal from Eastman Chemical Co.; d_6 -acetone from Cambridge Isotope Laboratories; phosphorous pentasulfide, zinc chloride from Fischer Scientific; benzyl 2-methyl-2-propenyl sulfide, *s*-butyl allyl sulfide, *n*-dodecyl allyl sulfide, *n*-hexyl allyl sulfide, phenyl allyl sulfide, sodium cyanoborohydride, triethylsilane, vinyltriethylsilane and vinyltrimethylsilane

from Lancaster Synthesis Inc.; allyl bromide, aluminum bromide, 1, 3-aminopropanol, bis (1, 5-cyclooctadiene) rhodium(I) tetrafluoroborate monohydrate, 1, 3-bis (diphenylphosphino) propane, boron trifluoride etherate, bromoacetophenone, 1-bromo-2-butene, 3-bromo-1-butene, bromocresol green, ethyl bromo acetate, *n*-butyl lithium, *t*-butyl lithium, cerium trichloride, chloro-*t*-butyldimethylsilane, chlorotriethylsilane, cobalt (II) chloride (hydrated and anhydrous), deuterated chloroform, d_6 -benzene, *N*-ethyl aniline, lithium aluminum hydride, *N*-methyl aniline, methyl iodide, methyl vinyl ketone, molybdenum hexacarbonyl, palladium acetate, 1-phenethylalcohol, pivaloyl chloride, potassium carbonate, silver hexafluorophosphate, silver tetrafluoroborate, sodium borohydride, sodium hydride, sodium tetraphenylborate, 1, 2, 3, 4-tetrahydroquinoline, tetrakis(triphenylphosphine)palladium, *N, N*, -dimethyl-formamide dimethylacetal, d_8 -toluene, α, α, α -trifluorotoluene, triethylamine, triphenylphosphine, triruthenium dodecacarbonyl, vinyltriethylsilane and vinyltrimethylsilane from Aldrich Chemical Co.; bis (1, 5-cyclooctadiene) iridium (I) tetrafluoroborate, chlorocarbonylbis (triphenylphosphine) iridium, chlorotricarbonyl iridium (I), dicobaltoctacarbonyl, iridium carbonyl, iridium (III) chloride (anhydrous and hydrated) and tricyclohexyl phosphine from Strem Chemical Co.

Autoclaves, gauges and gauge block assemblies were purchased from Parr Instrument Co. (screw cap bomb # 4712 and gauge block assembly # 4316).

6.2 Experimental for Chapter 2

6.2.1 General Procedure for the Hydroformylation Reactions

An autoclave, its glass liner and a magnetic stirring bar were dried in an oven and cooled in a dry box. The liner was charged with the catalyst (0.019 mmol, 0.6% unless otherwise noted), vinylsilane (3.2 mmol) and solvent (3 mL). An additional amount of solvent (from 2–9 mL) was placed in the autoclave prior to insertion of the liner. The gauge and gauge block assembly were attached. The CO line was flushed 3 times with CO and the system was pressurized and flushed 3 times, gradually increasing the pressure to the desired level. The system was then filled with the required amount of CO and the hydrogen line attached. The line was flushed 3 times with H₂ and the system was pressurized to the desired level. The autoclave was placed in the center of an oil bath on a heater stirrer preset to the reaction temperature. After the appropriate time, the autoclave was removed from the oil bath and cooled in either air or water. The excess gas was discharged and the system disassembled. The contents were analyzed first by GC using added *m*-dimethoxybenzene as the internal standard. GC yields and conversions are accurate to at best $\pm 5\%$. The products were then isolated by Kugelrohr reduced pressure distillation after removal of the volatiles *in vacuo*. After isolation and purification, NMR analyses were performed and the spectra compared with the literature (see below). The trimethylsilylaldehydes were found to be extremely sensitive to air, decomposing to give the corresponding acids and/or unidentified products within hours. As previously reported^{67, 69–71}, the stability of the aldehyde increases as the steric bulk of R in SiR₃ increases. Thus the triethylsilylaldehydes were considerably more stable than the trimethyl analogs, but oxidation was still observed after several days exposure to air.

For 2- and 3-trimethylsilylpropanal see references 72 and 65. For 3-triphenylsilylpropanal, see reference 69. For 2-triethylsilylpropanal see reference 73 (spectra not reported). For 3-triethylsilylpropanal see reference 68 (spectra not reported).

3-Triethylsilylpropanal: ^1H NMR (200 MHz, CDCl_3) δ 0.52 (q, $J = 8.0$ Hz., 6H, Si- $\text{CH}_2\text{-CH}_3$); 0.73–0.79, (m, 2H, Si- $\text{CH}_2\text{-CH}_2\text{-CHO}$); 0.92 (t, $J = 8.0$ Hz., 9H, Si- $\text{CH}_2\text{-CH}_3$); 2.31–2.38 (m, 2H, Si- $\text{CH}_2\text{-CH}_2\text{-CHO}$); 9.72 (t, $J = 2.8$ Hz., 1H, CHO) ppm.; ^{13}C NMR (75 MHz, CDCl_3) δ 2.8, 2.9, 7.11, 38.1, 202.7 ppm.; IR neat, ν_{max} 1696 cm^{-1} ;

2-Triethylsilylpropanal: ^1H NMR (200 MHz, CDCl_3) δ 0.66 (q, $J = 7.8$ Hz., 6H, Si- $\text{CH}_2\text{-CH}_3$); 0.96 (t, $J = 7.8$ Hz., 9H, Si- $\text{CH}_2\text{-CH}_3$); 1.19 (d, $J = 6.7$ Hz., 3H, Si- CH-CH_3); 2.5 (qd, $J = 6.7, 2.3$ Hz., 1H, Si- CH-CHO); 9.72 (m, 1H, CHO) ppm.; ^{13}C NMR (75 MHz, CDCl_3) δ 2.4, 7.06, 7.9, 40.5, 202.9 ppm.; IR neat, ν_{max} 1724 cm^{-1} .

Propanal-(Z)-triethylsilyl enol ether: ^1H NMR (200 MHz, CDCl_3) δ 6.21 (dq, $J = 5.8, 1.8$ Hz, 1H, SiOCH=), 4.50 (dq, $J = 6.8, 5.8$ Hz, 1H, = CHCH_3), 1.58 (dd, $J = 6.7, 5.8$ Hz, 3H, = CHCH_3), SiEt signals buried with silyl aldehyde signals. Small dd also observed at 1.5. ppm ($J = 6.8, 1.7$ Hz), which is likely due to the trans isomer, but it is less than 5%, and the alkene protons could not be observed.

6.2.2 Hydroformylation of Vinyltrimethylsilane

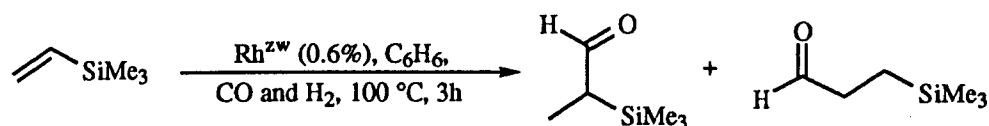

As in the general procedure, Rh^{zw} (10 mg, 0.019 mmol, 0.6%) was placed in a dry autoclave liner and 3 mL of distilled benzene added. Vinyltrimethylsilane (0.5 mL, 3.2 mmol) was added and the liner was inserted into the autoclave. The gauge and gauge

block assembly were attached and the system was pressurized with 70 psi of CO and 130 psi of H₂. After 4h at 100 °C, the autoclave was cooled and disassembled. Its contents were transferred to a round bottomed flask and the solvent and starting material removed on the rotary evaporator without heating. The crude reaction mixture was analyzed by ¹H NMR and the branched : linear ratio determined to be 56 : 44. Purification was effected by reduced pressure distillation and yielded 112 mg of the desired product (0.86 mmol, 27%). ¹H NMR analysis of this mixture showed that the branched to linear ratio had not changed (Table 5, entry 1).

A similar experiment performed on 3.2 mmole scale with C₆H₆, and left for 3 hours gave a 57 : 43 B : L ratio and 34% isolated yield (1.01 mmol, 141 mg) of the desired aldehydes (Table 5, entry 2).

Another experiment was performed on half the scale (1.6 mmol vinylsilane) in *d*₆-benzene using 0.3 % (5mg, 0.01 mmol) Rh^{zw}. After 3 hours, 100 mg of distilled anisole was added as internal standard and ¹H NMR analysis indicated that there was a 30% yield of the aldehydes (65 : 35 B : L) and 83% conversion with unmeasurable quantities of the enol silyl ether (Table 5, entry 3).

A similar experiment performed on 3.2 mmole scale with C₆H₆, gave a 70 : 30 B : L ratio and 20% isolated yield (0.64 mmol, 83 mg) of the desired aldehydes after reaction for 1.5 hours (Table 5, entry 4).

A hydroformylation run in *d*₆-benzene (1.5 mL) as described for entry 3 (above) gave 23% yield of a 65 : 35 mixture of branched and linear aldehydes with a conversion of 75% (Table 5, entry 5).

A hydroformylation run in *d*₆-benzene (1.5 mL) as described for entry 3 (above) but using twice the amount of vinylsilane (0.5 mL, 3.2 mmol) and the same amount of catalyst (5mg, 0.01 mmol, 0.3%) gave 17% yield of a 71 : 29 mixture of branched and linear aldehydes with a conversion of 69% (Table 5, entry 6).

A hydroformylation run in d_6 -benzene (1.5 mL) as described for entry 3 (above) with 0.6% catalyst and 0.6% triphenyl phosphine (5mg, 0.01 mmoles) gave 55% yield of a 11 : 89 mixture of branched and linear aldehydes with a conversion of 100% after 1.5 hours (Table 5, entry 7).

6.2.3 Hydroformylation of Vinyltriethylsilane in Benzene

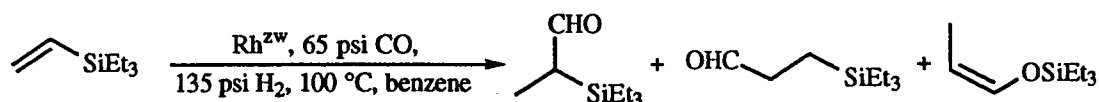

As in the general procedure, Rh^{zw} (10 mg, 0.019 mmol, 0.6%) and vinyltriethylsilane (0.6 mL, 3.2 mmol) were reacted in 3 mL of distilled benzene under 70 psi of CO and 130 psi of H_2 for 1.5h at 100 °C. After this time, *m*-dimethoxybenzene was added as a GC standard and the volatiles removed *in vacuo*. The crude reaction mixture was analyzed by GC and 1H NMR, and the reaction profile was determined to be as follows: B : L = 35 : 65, conversion = 74%, enol silyl ether = 6% (100% *cis*) and the yield of total aldehyde = 34%. Purification was effected by reduced pressure distillation affording 187 mg, (1.06 mmol, 33%) of the aldehydes. 1H NMR analysis of this mixture showed that the branched to linear ratio had not changed.

A similar experiment performed on an identical scale for 3 hours gave a 35 : 65 B : L ratio, a conversion of 90%, a GC yield of 48% and 40% isolated yield (1.28 mmol, 220 mg) of the desired aldehydes.

A similar experiment performed on an identical scale for 4 hours gave a 35 : 65 B : L ratio, a conversion of 96%, a GC yield of 84% and 66% isolated yield (2.11 mmol, 363 mg) of the desired aldehydes.

A similar experiment performed on an identical scale for 5 hours gave a 34 : 66 B : L ratio, a conversion of 99.5%, a GC yield of 72% and 55% isolated yield (1.76 mmol, 302 mg) of the desired aldehydes.

6.2.4 Rh^{zw} Catalyzed Hydroformylation of Vinyltriethylsilane in Various Solvents

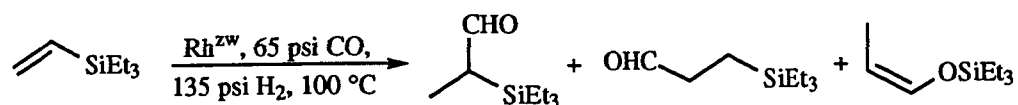

Vinyltriethylsilane (0.6 mL, 3.2 mmol) was treated with Rh^{zw} (10 mg, 0.019 mmol, 0.6%) in 3 mL of toluene. After 1.5h at 100 °C, the crude reaction mixture was analyzed by GC and ¹H NMR: B : L = 34 : 66, conversion = 95%, 8% of the enol silyl ether (100% *cis*) and 53% yield of the total aldehyde (Table 6, entry 2).

A similar experiment performed on an identical scale but run in α, α, α -trifluorotoluene gave a 28 : 72 B : L ratio, a conversion of 95%, a GC yield of 53%, and 11% of the enol silyl ether (Table 6, entry 3).

A hydroformylation run in anisole gave a 28 : 72 B : L ratio, a GC yield of 34% and 6% of the enol silyl ether. (Conversion could not be measured due to interference from the solvent peak in the GC.) (Table 6, entry 4)

A similar experiment performed on an identical scale but run in diethyl ether gave a 30 : 70 B : L ratio, a conversion of 32%, a GC yield of 27% and 4% of the enol silyl ether (Table 6, entry 5).

An analogous experiment performed on an identical scale but run in THF gave a 39 : 61 B : L ratio, a conversion of 38%, a GC yield of 28%, and 4% of the enol silyl ether (Table 6, entry 6).

A similar experiment performed on an identical scale but run in dichloromethane gave a 23 : 77 B : L ratio, a conversion of 74%, a GC yield of 32%, and 10% of the enol silyl ether (Table 6, entry 7).

A similar experiment performed on an identical scale but run in CHCl₃ gave a 5 : 95 B : L ratio, a conversion of 95%, a GC yield of 38%, and 20% of the enol silyl ether (Table 6, entry 8).

6.2.5 Rh⁺ Catalyzed Hydroformylation of Vinyltriethylsilane in Various Solvents

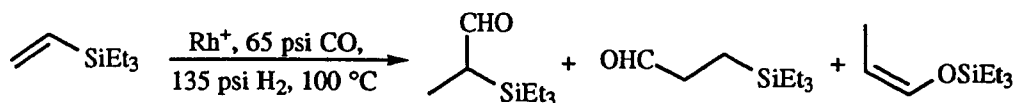

Vinyltriethylsilane (0.6 mL, 3.2 mmol) was reacted with Rh⁺ (7 mg, 0.019 mmol, 0.6%) in 3 mL of benzene under 70 psi of CO and 130 psi of H₂. After 3h at 100 °C, the crude reaction mixture was analyzed by GC and ¹H NMR: B : L = 35 : 65, conversion = 84%, 3% of the enol silyl ether (100% *cis*) and 50% yield of the total aldehyde (Table 7, entry 1).

A similar experiment performed on an identical scale for 1.5 h gave a 33 : 67 B : L ratio, a conversion of 82%, a GC yield of 40%, and 6% of the enol silyl ether (Table 7, entry 2).

A similar experiment performed on an identical scale for 1.5 h in toluene gave a 29 : 71 B : L ratio, a conversion of 78%, a GC yield of 31%, and 6% of the enol silyl ether (Table 7, entry 3).

A similar experiment performed on an identical scale for 1.5 h in α, α, α-trifluorotoluene gave a 29 : 71 B : L ratio, a conversion of 37%, a GC yield of 17%, and the amount of the enol silyl ether could not be determined due to interference of the solvent peak (Table 7, entry 4).

A similar experiment performed on an identical scale for 1.5 h and run in anisole gave a 20 : 80 B : L ratio, a GC yield of 25% and 5% of the enol silyl ether. (Conversion could not be measured due to interference from the solvent peak in the GC.) (Table 7, entry 5)

Experiments performed on an identical scale in diethyl ether or in CHCl_3 gave no reaction after 3h (Table 7, entries 6 and 7).

6.2.6 Additives in the Rh^{zw} and Rh^+ Catalyzed Hydroformylations

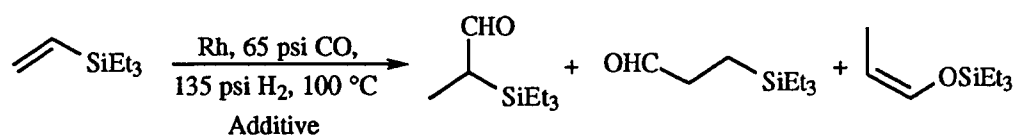

Vinyltriethylsilane (0.6 mL, 3.2 mmol), Rh^+ (7 mg, 0.019 mmol, 0.6%) and triphenylphosphine (5 mg, 0.019 mmol, 1 equiv) were reacted in 3 mL of benzene as in the general procedure. After 3h at 100 °C, the crude reaction mixture was analyzed by GC and ^1H NMR, and the reaction profile was determined to be as follows: B : L = 20 : 80, conversion = 100% and 93% yield of the total aldehyde (Table 8, entry 2).

A similar experiment performed on an identical scale with Rh^{zw} (10 mg, 0.019 mmol) and triphenylphosphine (5 mg, 0.019 mmol, 1 equiv) for 1.5 h in benzene gave a 20 : 80 B : L ratio, a conversion of 100%, a GC yield of 98% and an isolated yield of 91% (Table 8, entry 6).

Another experiment performed on an identical scale with Rh^{zw} (10 mg, 0.019 mmol) and triphenylphosphine (10 mg, 0.038 mmol, 3 equiv) for 1.5 h in benzene gave a 7 : 93 B : L ratio, a conversion of 100% and a GC yield of 97% (Table 9, entry 1).

A similar experiment performed on an identical scale with Rh^{zw} (10 mg, 0.019 mmol) and triphenylphosphine (20 mg, 0.076 mmol, 4 equiv) for 30 minutes in benzene

at 100 °C gave a 7 : 93 B : L ratio, a conversion of 100%, a GC yield of 100%, and an isolated yield of 90% (Table 9, entry 2).

A similar experiment performed on an identical scale with Rh^{zw} (10 mg, 0.019 mmol) and triphenylphosphine (20 mg, 0.076 mmol, 4 equiv) for 1.5 h in benzene at 65 °C gave a 7 : 93 B : L ratio and a GC yield of 86% (Table 9, entry 3).

A similar experiment performed on an identical scale with Rh^{zw} (10 mg, 0.019 mmol) and pyridine (3 μL, 0.038 mmol, 2 equiv) for 1.5 h in benzene at 100 °C gave a 32 : 68 B : L ratio, a conversion of 66 and a GC yield of 34%. The enol silyl ether was observed in 9% GC yield (Table 9, entry 4).

6.2.7 Ir⁺ Catalyzed Hydroformylation of Vinyltriethylsilane

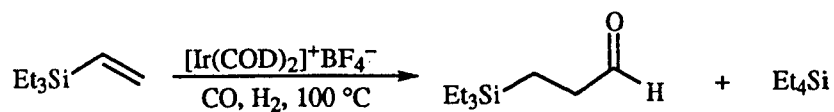

Vinyltriethylsilane (0.6 mL, 3.2 mmol) was mixed with Ir⁺ (30 mg, 0.057 mmol, 1.8%) in 3 mL of distilled benzene under 70 psi of CO and 130 psi of H₂. After 3h at 100 °C, the crude reaction mixture was analyzed by GC and ¹H NMR, and the reaction profile was determined to be as follows: B : L = 0 : 100, conversion = 100%, GC yield = 12%, isolated yield = 9% and 63% of tetraethylsilane was detected by GC (Table 10, entry 1).

A similar experiment performed on an identical scale using 300 psi of CO and 300 psi of H₂, for 3h in benzene gave a 5 : 95 B : L ratio, a conversion of 100%, a GC yield of 33%, an isolated yield of 23% and 60% hydrogenation by GC (hydroformylation : hydrogenation = 35 : 65) (Table 10, entry 2).

Another experiment performed on an identical scale using 600 psi of CO and 600 psi of H₂, for 3h in benzene gave a 0 : 100 B : L ratio, a conversion of 100%, a GC yield

of 32%, an isolated yield of 24% and 55% hydrogenation by GC (hydroformylation : hydrogenation = 37 : 63) (Table 10, entry 3).

A similar experiment performed on an identical scale using 500 psi of CO and 100 psi of H₂, for 3h in benzene gave a 3 : 97 B : L ratio, a conversion of 100%, a GC yield of 79%, an isolated yield of 65% and 25% hydrogenation by GC (hydroformylation : hydrogenation = 76 : 24) (Table 10, entry 4).

Another experiment performed on an identical scale using 1000 psi of CO and 100 psi of H₂, for 3h in benzene gave a 0 : 100 B : L ratio, a conversion of 37%, a GC yield of 20%, and 4% hydrogenation by GC (hydroformylation : hydrogenation = 86 : 14) (Table 10, entry 5).

A similar experiment performed on an identical scale using 700 psi of CO and 100 psi of H₂, for 3h in benzene gave a 3 : 97 B : L ratio, a conversion of 83%, a GC yield of 80%, an isolated yield of 60% and 15% hydrogenation by GC (hydroformylation : hydrogenation = 84 : 16) (Table 10, entry 6). (Note that in this experiment the GC yield and the hydrogenation add up to more than the conversion, which illustrates that the GC numbers are at best $\pm 5\%$.)

A similar experiment performed on an identical scale using 350 psi of CO and 50 psi of H₂, for 5h in benzene gave a 1 : 99 B : L ratio, a conversion of 36%, a GC yield of 33%, and 6% hydrogenation by GC (hydroformylation : hydrogenation = 86 : 14) (Table 10, entry 7).

A similar experiment performed on an identical scale using 700 psi of CO and 100 psi of H₂, for 5h in benzene at 140 °C gave a 10 : 90 B : L ratio, a conversion of 99%, a GC yield of 80%, an isolated yield of 60% and 11% hydrogenation by GC (hydroformylation : hydrogenation = 87 : 13) (Table 10, entry 8).

A similar experiment performed on an identical scale using 700 psi of CO and 100 psi of H₂, for 26h in benzene gave a 3 : 97 B : L ratio, a conversion of 70%, a GC

yield of 36%, and 4% hydrogenation by GC (hydroformylation : hydrogenation = 90 : 10) (Table 10, entry 9).

6.2.8 IrCl₃ Catalyzed Hydroformylation of Vinyltriethylsilane

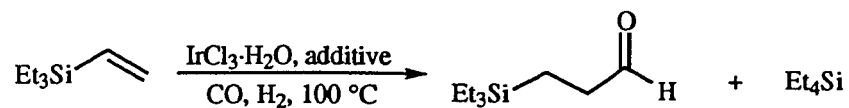

Vinyltriethylsilane (0.6 mL, 3.2 mmol) was treated with IrCl₃·H₂O (20 mg, 0.057 mmol, 1.8%) in 3 mL of a 1:1 mixture of benzene and dichloromethane. After 3h at 100 °C under 700 psi of CO and 100 psi of H₂, there was no reaction (Table 11, entry 1).

A similar experiment performed on an identical scale using benzene and chloroform also gave no reaction (Table 11, entry 2).

A similar experiment performed on an identical scale using added silver hexafluorophosphate (30 mg, 0.12 mmoles, 2.1 equiv. per Ir) and run for 14h in a benzene/chloroform mixture gave a 0 : 100 B : L ratio, a conversion of 100%, a GC yield of 54% and 21% hydrogenation by GC (Table 11, entry 3).

A similar experiment performed on identical scale but with only 0.6% IrCl₃·H₂O (6 mg, 0.02 mmol) in the presence of silver tetrafluoroborate (10 mg, 0.05 mmoles, 2.5 equiv. per Ir) gave a 0 : 100 B : L ratio, a conversion of 66%, a GC yield of 50% and 10% hydrogenation by GC after 14h (Table 11, entry 4).

A similar experiment performed on an identical scale (0.6% catalyst) using added silver tetrafluoroborate (8 mg, 0.04 mmoles, 2 equiv. per Ir) and run for 3h in a benzene/chloroform mixture gave no reaction (Table 11, entry 5).

As in the general procedure, IrCl₃·H₂O (6 mg, 0.019 mmol, 0.6%) and silver tetrafluoroborate (7 mg, 0.036 mmoles, 1.9 equiv. per Ir) were placed in a dry autoclave liner and 3 mL of a 1:1 mixture of distilled benzene and dichloromethane added and the

liner inserted into the autoclave. The gauge and gauge block assembly were attached and the system pressurized with 700 psi of CO and 100 psi of H₂. After 1h at 160 °C, the autoclave was cooled and disassembled. Vinyltriethylsilane (0.6 mL, 3.2 mmol) was added and the gauge and gauge block assembly were re-attached. (This will be referred to as the preactivation protocol.) The system pressurized with 700 psi of CO and 100 psi of H₂. After 3h at 100 °C, the autoclave was cooled and disassembled. Its contents were transferred to a round bottomed flask along with *m*-dimethoxybenzene as a GC standard and the volatiles removed *in vacuo*. Under these conditions, the desired aldehyde was obtained as a 2 : 98 mixture of B : L isomers, with a GC yield of 59% and a conversion of 92%. Tetraethylsilane was also observed in 16% yield. (Table 11, entry 6)

A similar experiment performed on an identical scale using added silver tetrafluoroborate (17 mg, 0.09 mmoles, 1.5 equiv. per Ir) and the preactivation protocol (45 minutes) and only chloroform as the solvent gave a 0 : 100 B : L ratio, a conversion of 99%, a GC yield of 54% and 32% hydrogenation by GC (Table 11, entry 7).

A similar experiment performed on an identical scale *without* added silver tetrafluoroborate using the preactivation protocol (45 minutes) and only chloroform as the solvent gave a 0 : 100 B : L ratio, a conversion of 99%, a GC yield of 46% and 18% hydrogenation by GC (Table 11, entry 8).

A similar experiment performed on an identical scale *without* added silver tetrafluoroborate and *without* the preactivation protocol in chloroform as the solvent gave no reaction (Table 11, entry 9).

6.2.9 Ir^{zw} Catalyzed Hydroformylation of Vinyltriethylsilane

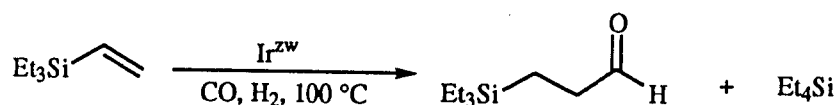

As in the general procedure, vinyltriethylsilane (0.6 mL, 3.2 mmol) was treated with $[\text{Ir}(\text{COD})]^+\text{BPh}_4^-$ (12 mg, 0.019 mmol, 0.6%) in 3 mL of dry distilled chloroform. After 3h at 100 °C under 700 psi of CO and 100 psi of H₂, the desired aldehyde was obtained as a 9 : 91 mixture of B : L isomers, with a GC yield of 8% and a conversion of 19%. Tetraethylsilane was also observed in 3% yield. (Table 12, entry 1)

The reaction was performed as above on identical scale and after 4h at 100 °C, the desired aldehydes were obtained as a 9 : 91 B : L mixture in 29% GC yield with 43% conversion and 7% hydrogenation (Table 13, entry 2)

After 5h at 100 °C as in the above procedure on an identical scale, the desired aldehydes were obtained as a 7 : 93 B : L mixture in 82% GC yield with a 100% conversion and 26% hydrogenation (Table 13 entry 3)

As in the above procedure using an identical scale, after 1.5h at 160 °C, the desired aldehydes were obtained as a 9 : 91 B : L mixture in 70% GC yield with a 100% conversion and 21% hydrogenation (Table 13, entry 4)

As in the general procedure, $[\text{Ir}(\text{COD})]^+\text{BPh}_4^-$ (12 mg, 0.019 mmol, 0.6%) was dissolved in 3 mL of chloroform and heated to 160 °C under 700 psi of CO and 100 psi of H₂ for 1h. Vinyltriethylsilane (0.6 mL, 3.2 mmol) was added and the system re-pressurized with 700 psi of CO and 100 psi of H₂. After 3h at 100 °C, the desired aldehyde was obtained as a 9 : 91 mixture of B : L isomers, with a GC yield of 87%, an isolated yield of 75% and a conversion of 100%. Tetraethylsilane was also observed in 16% yield. (Table 12, entry 2).

As in the above procedure using an identical scale, after preactivation for 1h at 160 °C, the substrate was added and the reaction continued at 60 °C for 3h. Under these conditions, there was no reaction (Table 12 entry, 3)

As in the procedure for Table 12, entry 2, Ir^{zw} (2 mg, 0.003 mmol, 0.1%) was added to the autoclave liner along with 3 mL of chloroform. After preactivation for 1h at 160 °C, vinyltriethylsilane was added and the reaction continued at 100 °C for 3h. The

desired aldehydes were obtained as a 10 : 90 B : L mixture in 33% GC yield with 51% conversion and 6% hydrogenation measured by GC (Table 12, entry 4).

As in the procedure for the above reaction, Ir^{zw} (2 mg, 0.003 mmol, 0.1%) was added to the autoclave liner along with 3 mL of chloroform. After preactivation for 1h at 160 °C, vinyltriethylsilane (0.6 mL, 3.2 mmol) was added and the reaction continued at 100 °C for 9h. After purification by reduced pressure distillation, the desired aldehyde was obtained as a 6 : 94 ratio of B : L isomers in 73% isolated yield (Table 12, entry 5).

6.2.10 Miscellaneous Hydroformylations of Vinyltriethylsilane

Effect of Phosphine on the Ir^{zw} Catalyzed Hydroformylation of Vinyltriethylsilane

As in the general procedure, [Ir(COD)]⁺BPh₄⁻ (12 mg, 0.019 mmol, 0.6%) and PPh₃ (5 mg, 0.019 mmol, 1 equiv. per Ir) were preactivated under 700 psi of CO and 100 psi of H₂ for 1h at 160 °C. Vinyltriethylsilane (0.6 mL, 3.2 mmol) was added and the hydroformylation continued for 3h at 100 °C. Under these conditions there was no reaction. This procedure was repeated 3 times with different PPh₃ sources, but each time there was no reaction.

Ir₄(CO)₁₂ Catalyzed Hydroformylation of Vinyltriethylsilane

[Ir₄(CO)₁₂] (21 mg, 0.019 mmol, 0.6%) was and preactivated in 3 mL of chloroform 1h at 160 °C. Vinyltriethylsilane was added and the reaction continued for 3h at 100 °C. Analysis of the crude reaction mixture gave the following reaction profile: 6 : 94 B : L, 27% GC yield, 19% isolated yield (106 mg, 0.6 mmol), with 48% conversion and 8% hydrogenation. The same reaction without preactivation gave only 0.9% of the aldehyde by GC, 0.6% hydrogenation and 26% conversion.

[Ir(COD)Cl]₂ Catalyzed Hydroformylation Of Vinyltriethylsilane

As in the general procedure, [Ir(COD)Cl]₂ (7 mg, 0.019 mmol, 0.6%) was dissolved in 3 mL of chloroform and preactivated for 1h at 160 °C. Vinyltriethylsilane (0.6 mL, 3.2 mmol) was added and the reaction continued for 3h at 100 °C. The desired aldehydes were obtained as a 8 : 92 B : L mixture in 81% GC yield, with 99% conversion and 12% hydrogenation.

[IrCl(CO)(PPh₃)₂] Catalyzed Hydroformylation Of Vinyltriethylsilane

As in the general procedure, [IrCl(CO)(PPh₃)₂] (15 mg, 0.019 mmol, 0.6%) was dissolved in 3 mL of chloroform and preactivated for 1h at 160 °C, after which time vinyltriethylsilane (0.6 mL, 3.2 mmol) was added. After 3h at 100 °C, there was no reaction.

The hydroformylation was run at 160 °C instead of 100 °C, under otherwise identical conditions (3.2 mmol scale and 0.6% catalyst). After three hours, a 39% yield of the desired aldehyde was detected by GC (178 mg were isolated by distillation, 1.03 mmol, 32%) with a 0 : 100 B : L ratio, 10% hydrogenation and 93% conversion.

[Ir(CO)₃Cl] Catalyzed Hydroformylation Of Vinyltriethylsilane Without Preactivation

As in the general procedure, [Ir(CO)₃Cl] (6 mg, 0.019 mmol, 0.6%) and vinyltriethylsilane (0.6 mL, 3.2 mmol) were mixed in 3 mL of chloroform. After 3h at 100 °C (no preactivation), the desired aldehydes were obtained as a 0 : 100 B : L mixture in 55% GC yield, 43% isolated yield with 100% conversion and 21% hydrogenation.

Attempted Hydroformylation of Vinyltriethylsilane with CoCl₂ and AgBF₄

As in the general procedure, CoCl₂ (30 mg, 0.23 mmol, 7%) silver tetrafluoroborate (62 mg, 0.32 mmol, 1.6 equiv per Co) and vinyltriethylsilane (0.6 mL, 3.2 mmol) were mixed in 2 mL of chloroform and 2 mL of benzene. After 3h at 100 °C, there was no reaction.

Hydroformylation of Vinyltriethylsilane with Co Complex (34)

As in the general procedure, $[\text{Co}_3(\eta^6\text{-C}_6\text{H}_6)_3(\text{CO})_2]^+\text{BPh}_4^-$, (**34**), (3 mg, 0.004 mmol, 0.1%) was transferred to a dry autoclave liner with 3 mL of distilled benzene in a glove bag. Vinyltriethylsilane (0.6 mL, 3.2 mmol) was added and the autoclave assembled in the glove bag. The autoclave was stoppered and removed from the glove bag and the gauge and gauge block assembly quickly attached. The system was pressurized with 70 psi of CO and 130 psi of H₂. After 3h at 100 °C, the autoclave was cooled and disassembled. Its contents were transferred to a round bottomed flask along with *m*-dimethoxybenzene as a GC standard and the volatiles removed *in vacuo*. Under these conditions, the desired aldehyde was obtained as a 24 : 76 mixture of B : L isomers, with a GC yield of 33% and a conversion of 100%. Tetraethylsilane was also observed in 9% yield.

6.3 Experimental for Chapter 3

6.3.1 General Details

The hydroformylation reactions described in this chapter are all performed using the same procedure as previously described for the hydroformylation reactions described in Chapter two.

Experiments designed to determine the stability of Rh^{zw} under the reaction conditions were run in exactly the same manner, except the vinylsilane was not added until a sample of the reaction mixture was removed for NMR analysis, and the internal standard (isobutyl ether) was added at the beginning of the reaction. After the prescribed time, the autoclave was cooled and the excess gas released. The gauge block assembly

was loosened slightly, and the entire apparatus transferred to a glove bag. The bag was filled three times with nitrogen and the gauge and gauge block assembly removed. A syringe with a 10" needle was used to withdraw 0.5 mL of the orange solution from inside the autoclave. This was transferred to an NMR tube, (which had been previously flushed with nitrogen), and the tube was stoppered. Vinyltriethylsilane (0.6 mL, 3.2 mmol) was added to the autoclave and the gauge and gauge block assembly reattached. The autoclave and gauge were removed from the glove bag and the gauge tightened. The system was flushed with CO and the hydroformylation reaction set up as described in Chapter 2. In all cases except the experiment where HCl is added, the reaction mixture was catalytically active for the hydroformylation of vinyltriethylsilane. The extent of decomposition of Rh^{zw} was measured by ¹H NMR versus the internal standard.

6.3.2 High Pressure NMR Experiments

High pressure NMR experiments were run in thick walled NMR tubes (Aldrich) which had been fitted with glass stopcocks containing female joints. Rh^{zw} was placed in the NMR tube along with CDCl₃, and the stopcock closed. The tube was attached to a small vacuum line via the female joint, and the contents degassed using three freeze-pump-thaw cycles. The system was then filled with enough syn gas (1:1) to give ca. 5-6 atm. pressure at room temperature (the amount of gas required was approximated from the volume of the vacuum line using the equations $PV=nRT$ and $V_{(cylinder)}=\pi r^2 l$). The stopcock on the vacuum line was closed and the NMR tube immersed in liquid nitrogen to condense all of the gas. After 5 minutes, the stopcock on the NMR tube was closed, and the tube flame-sealed (caution: do not remove body of tube from liquid nitrogen). The NMR tube was slowly brought to room temperature and then slowly heated to the desired temperature. The NMR tube was cooled to room temperature and then analyzed by ¹H or ¹³C NMR.

Under all conditions, in the presence or absence of vinylsilane, up to temperatures of 100 °C, no hydroformylation took place and decomposition to metallic rhodium was the only observable reaction. In addition, the NMR tube was heated to 70 °C in the probe of the 300 MHz NMR, but no hydroformylation was observed.

6.3.3 Treatment of Rh^{zw} with CO and H₂ in an Autoclave.

- (a) As in the general procedure, Rh^{zw} (10.5 mg, 0.0198 mmol) and isobutyl ether (10.2 mg, 0.078 mmol) were mixed in 3 mL of CDCl₃ and heated to 75 °C for 3.5h under 70 psi of CO and 130 psi of H₂. ¹H NMR analysis showed 14% decomposition to benzaldehyde and no detectable benzyl alcohol or benzene.
- (b) Rh^{zw} (22 mg, 0.042 mmol) and isobutyl ether (5 mg, 0.039 mmol) were mixed in 3 mL of CDCl₃ and heated to 130 °C for 3h under CO and H₂ as previously described. This procedure led to 16% decomposition to benzaldehyde and traces of benzene and benzyl alcohol.
- (c) Rh^{zw} (20 mg, 0.038 mmol) and isobutyl ether (5.5 mg, 0.042 mmol) were mixed in 3 mL CDCl₃ and heated to 140 °C for 16h under 150 psi of CO and 300 psi of H₂. ¹H NMR analysis of this material showed 21% benzaldehyde, 8% benzyl alcohol and ca. 5–10% benzene (taking into account the larger error in this integration because of the presence of the other aromatic resonances.)
- (d) Under identical conditions, except using untreated CDCl₃, 22% benzaldehyde, 6% benzyl alcohol and ca. 10-15% benzene were observed.
- (e) Rh^{zw} (14.3 mg, 0.027 mmol) and isobutyl ether (5.3 mg, 0.041 mmol) were mixed with untreated CDCl₃ and 2 drops of distilled water were added. Reaction under the conditions described in entry c gave 25% benzaldehyde, 3% benzyl alcohol and ca. 5% benzene.

(f) Under identical conditions, the addition of 4 drops of concentrated HCl caused the complete decomposition of the catalyst without the formation of benzaldehyde, benzyl alcohol or benzene, and the resulting mixture did not catalyze the hydroformylation of vinyltriethylsilane.

6.3.4 Hydroformylation with Cationic Arene-Rhodium Complexes.

All hydroformylation reactions with cationic rhodium complexes were performed as described in the general carbonylation procedure given in Chapter Two. The cationic rhodium-arene complexes were prepared as described in references 111 and 114.

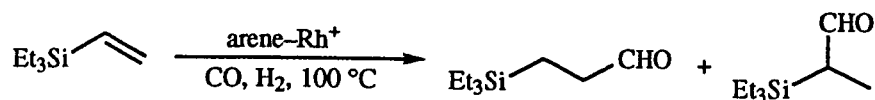

As in the general procedure, $[\text{Rh}(\text{COD})_2]^+\text{BF}_4^-$, (Rh^+) did not catalyze the hydroformylation of vinyltriethylsilane after 3h at 100 °C in diethylether or in chloroform (Table 14-entries 2 and 6). Rh^+ did catalyze the hydroformylation of vinyltriethylsilane in toluene giving 31% GC yield (B : L = 29 : 71) and 78% conversion after 1.5h at 100 °C. (Table 14-entry 8)

$[\text{Rh}(\text{COD})\eta^6\text{-C}_6\text{H}_5\text{CH}_3]^+\text{BF}_4^-$, Rh^{tol} , (**40**, 7.5 mg, 0.019 mmol, 0.6%) also catalyzed the hydroformylation of vinyltriethylsilane (0.6 mL, 3.2 mmol) in 3 mL of diethyl ether giving 40% yield (GC) of the desired aldehydes as a 37 : 63 mixture of branched and linear isomers in 89% conversion along with 16% of the enol silyl ether after 3h at 100 °C. (Table 14-entry 3)

Rh^{tol} , (**40**, 5.7 mg, 0.015 mmol, 0.5%) catalyzed the hydroformylation of vinyltriethylsilane (0.6 mL, 3.2 mmol) in 3 mL of dichloromethane affording 25% of the

desired aldehydes (B : L = 9 : 91) with a 72% conversion and 11% of the enol silyl ether after 3h at 100 °C. (Table 14–entry 7)

6.3.5 Preparation of Chiral Cationic Arene–Rhodium Complexes.

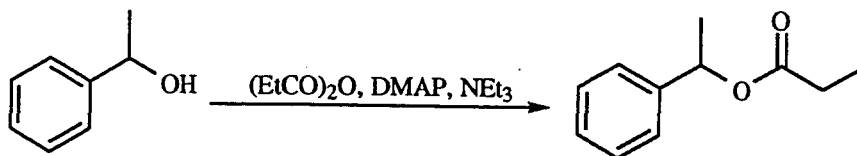

Propionic acid 2-(phenylethyl) ester (42). 1-Phenylethanol (2 mL, 16.6 mmol) was dissolved in 60 mL of dry distilled dichloromethane and treated with triethylamine (2.6 mL, 19.9 mmol), DMAP (200 mg, 1.66 mmol, 10%), and propionic anhydride (2.6 mL, 19.9 mmol). After the reaction was complete as determined by TLC analysis, workup was affected by partitioning the reaction mixture between water and dichloromethane. The layers were separated and the water layer back extracted with dichloromethane. The combined organic layers were dried over anhydrous magnesium sulfate, filtered and concentrated. Purification by flash chromatography on silica gel eluting with ethylacetate and hexanes gave the desired product (2.6 g, 14.5 mmol, 87%) whose spectra matched those reported in the literature.¹⁴⁶ A similar reaction performed with (S)-(-)-1-phenylethanol on 2.25 mmole scale (275 mg) yielded 64% of the desired ester.

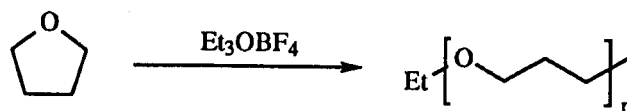

Poly-THF. As reported in reference 114, [Rh(NBD)Cl]₂ (54 mg, 0.23 mmol) and the racemic ester (42) (50 mg, 0.28 mmol) were dissolved in 2 mL of THF. Instead of using AgCl, triethyloxonium tetrafluoroborate (1M in dichloromethane, 0.23 mL, 0.23 mmol)

was added dropwise to the yellow solution. After 5 minutes, the THF had completely polymerized. A similar experiment performed without rhodium or arene also gave polymerized THF. The polymer was isolated by dissolution in dichloromethane and precipitation in pentane. Drying of the gummy white material thus obtained *in vacuo* gave a slightly transparent white solid. The ^1H and ^{13}C NMR spectra of this material was measured to confirm that it was poly-THF.

^1H NMR (200 MHz, CDCl_3) δ 3.45, (br s, 4H, CH_2OCH_2), 1.65 (br s, 4H, $\text{OCH}_2\text{CH}_2\text{CH}_2$) ppm; ^{13}C NMR (75 MHz, CDCl_3) δ 70.6, 26.3 ppm.

Preparation of Rhodium-Arene Complex (43).

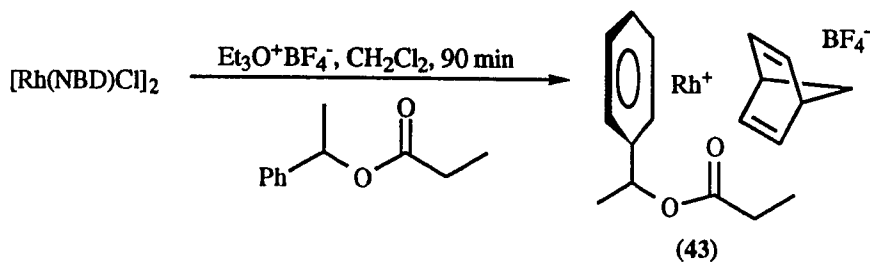

Complex (43). A similar experiment was performed in distilled dichloromethane (3 mL) using $[\text{Rh}(\text{NBD})\text{Cl}]_2$ (54 mg, 0.23 mmol), 100 mg of ester (42) (0.56 mmol) and 0.25 mL (0.25 mmol) of a solution of triethyloxonium tetrafluoroborate in dichloromethane. After 1.5 hours, ether was added and the resulting yellow-brown solid was filtered and then dried *in vacuo* (10 mg, 0.027 mmol, 10%). Analysis of this material by ^1H NMR showed that the arene complex had formed. The key features are the upfield shift of the protons on the co-ordinated arene.

^1H NMR (200 MHz, CDCl_3) δ 7.096.60 (m, 5H, Ar-H), 4.87 (q, $J = 7.0$ Hz, 1H, PhCH), 4.26 (br s, 4H, =CH), 3.42 (br s, 2H, =CHCH x 2), 2.49 (q, $J = 7.0$ Hz, 2H, COCH_2), 1.63 (d, $J = 7.0$ Hz, 3H, CH_3CH), 1.29–1.16 (m, 5H, CH_2 (NBD) and CH_2CH_3) ppm.

6.3.6 Catalytic Activity of Chiral Cationic Arene-Rhodium Complexes.

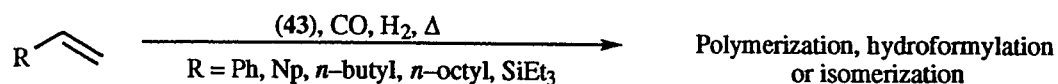

For the attempted hydroformylation reactions, the same procedure was carried out as described for the preparation of (43) except in the glass liner of an autoclave. The arene complex was not isolated in these cases, instead, after 2 hours, the substrate was added and the liner quickly transferred to the autoclave. The hydroformylation reaction was carried out as previously described. When styrene was used as the olefin, only polymerization was observed regardless of the pressure, temperature, percent catalyst or gas ratio. Vinyl naphthalene was also polymerized under these conditions. 1-Decene was hydroformylated with this arene complex, but large amounts of alkene isomerization made interpretation of the results difficult. Finally, vinyltriethylsilane was hydroformylated with the rhodium arene complex (43), but all of the branched isomer was converted into the enol silyl ether (GC, NMR).

6.4 Experimental for Chapter 4

6.4.1 Preparation of Starting Materials

6.4.1.1 Preparation of Starting Material for Section 4.2.1

Alkylation of 1, 2, 3, 4-Tetrahydroquinoline with Ethyl Bromide

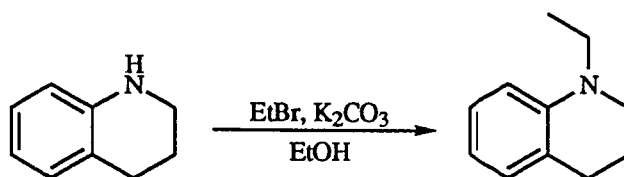

1-Ethyl-1, 2, 3, 4-tetrahydroquinoline. Using the same procedure reported in reference 55, compound 51 was prepared in 55% isolated yield.

¹H NMR (200 MHz, CDCl₃) δ 7.09-6.88 (m, 2H, Ar-H), 6.62-6.50 (m, 2H, Ar-H), 3.39-3.27 (m, 4H, NCH₂CH₃ and NCH₂CH₂), 2.80-2.67 (m, 2H, NCH₂CH₂), 1.99-1.86 (m, 2H, NCH₂CH₂CH₂), 1.12 (t, *J* = 7 Hz, 3H, NCH₂CH₃) ppm; ¹³C NMR (75 MHz, CDCl₃) δ 145.1, 129.3, 127.2, 122.5, 115.5, 110.7, 48.6, 45.5, 28.4, 22.5, 11.0 ppm; IR neat, ν_{max} 2919, 1601, 1502, 1342, 1195, 1135, 1102, 1077, 925, 876, 794, 742 cm⁻¹; MS (*m/z*) 161 (M⁺), 148 (100), 130, 118, 91, 77; HRMS calcd for C₁₁H₁₅N 161.1204, found 161.1214

6.4.1.2 Preparation of the Starting Material for Section 4.2.2

Modified procedure for the Preparation of 1-ethyl-4-phenylquinazolin-2-one (56).

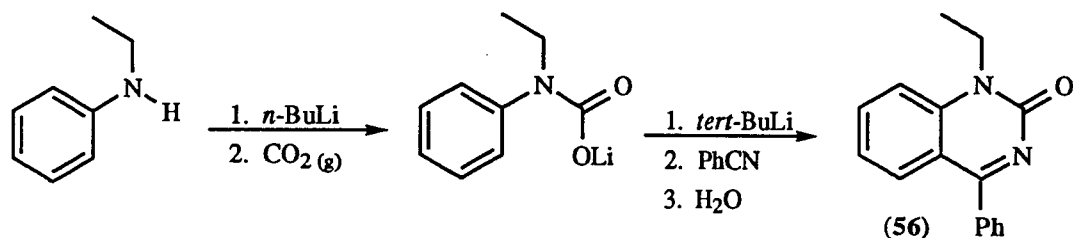

1-Ethyl-4-phenylquinazolin-2-one. A 500 mL, 3-necked flask was oven dried along with one stopper, a stirring bar and two vacuum adapters. After assembly of these pieces while hot, the system was flame dried under a purge of dry nitrogen. After cooling, THF (240 mL) and *N*-ethylaniline (5 mL, 80 mmol, distilled from CaH_2) were added to the flask and the mixture cooled to $-78\text{ }^\circ\text{C}$. A 2.5M solution of $n\text{-BuLi}$ in hexanes (36 mL, 90 mmol) was then added slowly with stirring. The white suspension that resulted was allowed to stir at $-78\text{ }^\circ\text{C}$ for 10 min before warming to $0\text{ }^\circ\text{C}$ for 20 min at which temperature the solid dissolved. The flask was then immersed in an ice/salt bath (NaCl) and cooled for 10 min before the addition of $\text{CO}_2(\text{g})$ to the reaction mixture via cannula (16G). It is important to use at least a 16G needle and not to allow the solution temperature to rise above $0\text{ }^\circ\text{C}$ or the bright yellow solution will turn brown and the reaction will fail. After bubbling for 20 min, the THF was removed *in vacuo* through the use of one of the vacuum adapters. Slight heating of the flask was necessary at this point to facilitate the removal of the THF, but the flask should not go above $0\text{ }^\circ\text{C}$, or else the pale yellow/green carbamate salt will decompose to give a darker yellow or even brown decomposed material. The scale of the procedure is limited by this step since a large trap must be used to capture the THF (240 mL in this case). Due to the temperature sensitivity of the lithiocarbamate, it is important to re-introduce the solvent and cool the

solution immediately. Thus dry, distilled diethyl ether (144 mL) was added to the flask along with THF (58 mL) while the flask was immersed in a dry-ice acetone bath. After cooling for 10 min, a solution of *t*-BuLi (56 mL, 96 mmol of a 1.7M solution in pentane) was added and the reaction mixture was stirred at $-78\text{ }^{\circ}\text{C}$ for 15 min and then at $-10\text{ }^{\circ}\text{C}$ for 90 min. The flask was then cooled in a dry ice/acetone bath for 10 min. Dry distilled benzonitrile (5 mL, 96 mmol) was added to a flame dried 50 mL flask and dissolved in 20 mL of ether. This solution was transferred via cannula to the reaction mixture which became red. The reaction mixture was left to warm to room temperature slowly overnight.

Workup was effected by cooling the flask to $0\text{ }^{\circ}\text{C}$ in an ice bath and an Erlenmyer flask containing a mixture of CHCl_3 and H_2O was also cooled in ice. The reaction mixture was then added slowly to the $\text{CHCl}_3/\text{H}_2\text{O}$ mixture via a large gauge cannula. The resulting mixture was poured into a separatory funnel and the layers were separated. The aqueous layer was extracted with chloroform until the organic layers were colourless. The combined organic layers were dried over anhydrous Na_2SO_4 , filtered and the volatiles removed *in vacuo*. The oil recovered from this procedure was recrystallized from methanol. A second batch was obtained by treatment of the mother liquor with hexanes to precipitate the product which was again recrystallized with methanol. This procedure yielded a total of 4.87 g (19.5 mmol, 25%) of compound 56. The spectra of this compound were compared to those reported in reference 123.

Preparation of 1-ethyl-4-phenylquinazolin-2-ol (59).

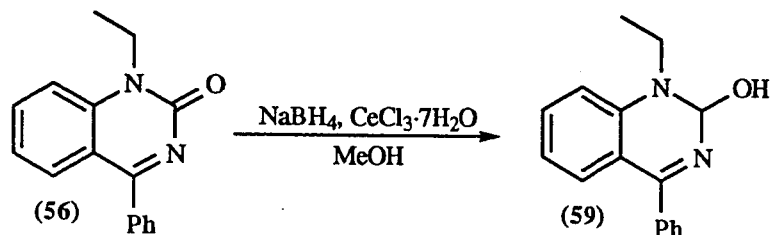

1-Ethyl-4-phenylquinazolin-2-ol. 1-Ethyl-4-phenylquinazolin-2-one **56** (1.5 g, 6 mmol) was dissolved in 15 mL of methanol and cerium trichloride heptahydrate (2.24 g, 6 mmol) was added. Sodium borohydride (0.45 g, 12 mmol) was then added portionwise to this reaction mixture (caution—hydrogen is evolved). The reaction was continued for 15 minutes after which time TLC analysis indicated that the starting material was consumed. The slow addition of water was used to quench the reaction, and the resulting mixture was extracted six times with ether. The combined organic layers were dried with anhydrous MgSO_4 , filtered and the volatiles were evaporated *in vacuo*. Recrystallization of the solid that resulted from this procedure yielded 1.36 g (90%) of the desired compound (**59**).

^1H NMR (200 MHz, CDCl_3) δ 7.34-7.17 (m, 6H, ArH), 6.97-6.78 (m, 3H, Ar-H), 5.52 (s, 1H, NCH(OH)N), 5.08 (br s, 1H, NCH(OH)N), 3.99 (q, $J = 7.0$ Hz, 2H, NCH_2CH_3), 1.28 (t, $J = 7.0$ Hz, 3H, NCH_2CH_3) ppm; ^{13}C NMR (75 MHz, D_3CCOCD_3) δ 154.3, 145.3, 138.2, 130.2, 128.9, 128.4, 128.3, 127.3, 127.2, 121.9, 113.2, 57.8, 37.1, 12.7 ppm; IR neat, ν_{max} 3221 (br), 2973, 1669, 1601, 1465, 1416, 1257, 1196, 753, 731 cm^{-1} .

6.4.1.3 Preparation of the Starting Materials for Section 4.2.3

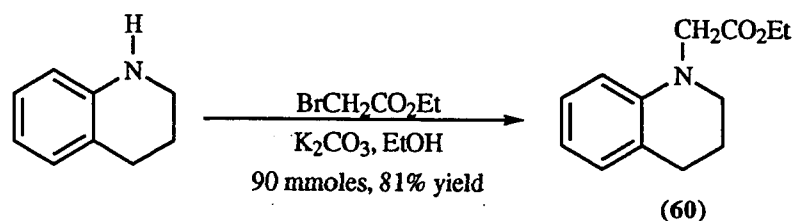
Preparation of 1-[(ethoxycarbonyl)methyl]-1, 2, 3, 4-tetrahydroquinoline (60)

1-[(Ethoxycarbonyl)methyl]-1, 2, 3, 4-tetrahydroquinoline. A 500 mL round bottomed flask was charged with 1, 2, 3, 4-tetrahydroquinoline (11.5 mL, 90.0 mmol) and 230 mL of ethanol (95%). Potassium carbonate (12 g, 90 mmol) and ethyl bromoacetate (10 mL, 90 mmol) were added and the mixture was stirred vigorously overnight. In the morning, the reaction was worked up by filtration of the precipitated potassium bromide (along with any remaining potassium carbonate) and thorough washing with dichloromethane. Removal of the volatiles *in vacuo* yielded a red oil that was purified by Kugelrohr distillation at ultimate vacuum and 80 °C. This procedure yielded 15.94 g (72.7 mmol, 81%) of the desired product as a red oil.

^1H NMR (200 MHz, CDCl_3) δ 7.23–6.92 (m, 2H, Ar-*H*), 6.63–6.55 (m, 1H, Ar-*H*), 6.41–6.37 (m, 1H, Ar-*H*), 4.16 (q, $J = 7.1$ Hz, 2H, OCH_2CH_3), 3.97 (s, 2H, NCH_2CO), 3.41–3.35 (m, 2H, NCH_2), 2.77 (t, $J = 6.3$ Hz, 2H, $\text{NCH}_2\text{CH}_2\text{CH}_2$), 2.04–1.90 (m, 2H, NCH_2CH_2), 1.23 (t, $J = 7.1$ Hz, 3H, OCH_2CH_3) ppm.; ^{13}C NMR (75 MHz, CDCl_3) δ ppm.; IR neat, ν_{max} 2914, 1739, 1602, 1578, 1502, 1449, 1370, 1224, 1116, 1029, 971, 747, 716 cm^{-1} ; MS (m/z) 219 (M^+), 146 (100), 130, 118, 91. HRMS calcd. for $\text{C}_{13}\text{H}_{17}\text{NO}_2$: 219.1259. Found: 219.1253.

Preparation of 1-(benzoylmethyl)-1, 2, 3, 4-tetrahydroquinoline (61)

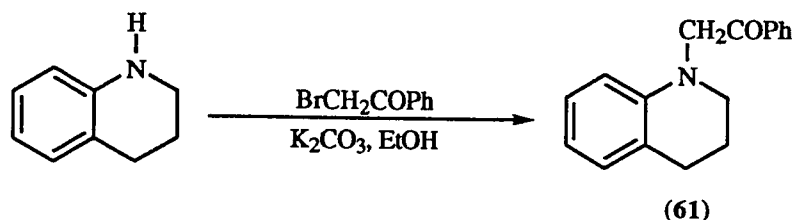

1-(Benzoylmethyl)-1, 2, 3, 4-tetrahydroquinoline. In a round bottomed flask were mixed 1, 2, 3, 4-tetrahydroquinoline, (5 mL, 79.7 mmol), bromoacetophenone (purified by sublimation, 7.9 g, 79.7 mmol), potassium carbonate (6.1 g, 87.6 mmol) and 160 mL of 95% ethanol. The flask was flushed with nitrogen and stoppered. The precipitation of potassium bromide started soon after the reagents were mixed. After stirring vigorously for 12 hours, the potassium bromide was filtered through a sintered glass funnel and rinsed well with methylene chloride. The filtrate was partitioned between dichloromethane and water, the layers were separated and the water layer extracted with dichloromethane (5 x 200 mL). After drying and concentration, the yellow solid that resulted was purified by recrystallization using THF, MeOH and ether (2.4 g, 10 mmol, 12%).

^1H NMR (200 MHz, CDCl_3) δ 8.00–7.95 (m, 2H, Ar-*H*), 7.57–7.42 (m, 3H, Ar-*H*), 6.97–6.89 (m, 2H, Ar-*H*), 6.61–6.53 (m, 1H, Ar-*H*), 6.31–6.27 (m, 1H, Ar-*H*), 4.68 (s, 2H, NCH_2CO), 3.40–3.34 (m, 2H, NCH_2), 2.84–2.77 (m, 2H, $\text{NCH}_2\text{CH}_2\text{CH}_2$), 2.06–1.97 (m, $2\text{HNCH}_2\text{CH}_2$) ppm.; ^{13}C NMR (75 MHz, CDCl_3) δ 196.4, 145.0, 135.5, 133.4, 129.1, 128.7, 127.7, 127.0, 122.7, 116.5, 110.2, 57.6, 50.5, 28.0 22.3 ppm.; IR neat, ν_{max} 2952, 2839, 1686, 1598, 1500, 1452, 1344, 1302, 1223, 977, 745, 688 cm^{-1} ; MS (*m/z*) 251 (M^+), 220, 146 (100), 130, 105, 84, 77; HRMS calcd. for: $\text{C}_{17}\text{H}_{17}\text{NO}$: 251.1310. Found: 251.1326.

Preparation of 1-(benzoylmethyl)-1-methylaniline (63)

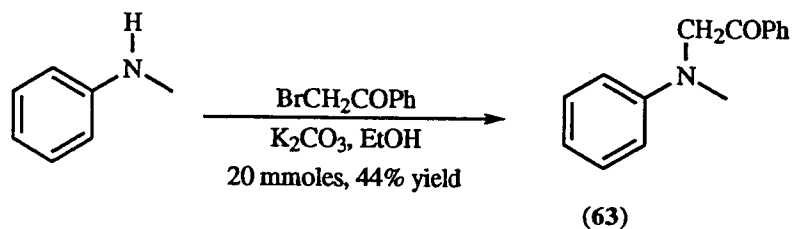

1-(Benzoylmethyl)-1-methylaniline. A 250 mL round bottomed flask was charged with *N*-methylaniline (2.2 mL, 20 mmol) and potassium carbonate (3 g, 22 mmol). Ethanol was then added (75 ml of 95%) followed by bromoacetophenone (4 g, 20 mmol). The solution became darker yellow at this point, and after 1 hour, precipitation of KBr could be observed. The resulting mixture was stirred overnight. In the morning, the reaction was worked up by filtration of the precipitated potassium bromide (along with any remaining potassium carbonate) and thorough washing with dichloromethane. Removal of the volatiles *in vacuo* yielded a yellow solid that was purified by recrystallization from dichloromethane (1st batch: 1.13 g, 2nd batch: 0.84 g, total yield = 1.97 g, 8.8 mmol, 44%). This procedure yielded a bright yellow highly crystalline material with a melting point of 114–115 °C.

¹H NMR (200 MHz, CDCl₃) δ 7.99–7.94 (m, 2H, Ar-*H*), 7.57–7.46 (m, 3H, Ar-*H*), 7.23–7.14 (m, 2H, Ar-*H*), 6.70–6.63 (m, 2H, Ar-*H*), 4.75 (s, 2H, NCH₂), 3.08 (s, 3H, NCH₃) ppm.; ¹³C NMR (75 MHz, CDCl₃) δ 196.2, 149.0, 135.3, 129.0, 128.8, 128.6, 127.5, 116.8, 112.0, 58.7, 39.3 ppm; IR neat, ν_{max} 1692, 1598, 1509, 1217, 1113, 848, 750, 690 cm⁻¹; MS *m/z* 225 (M⁺), 120 (100), 104, 77, 51.; HRMS, calcd for C₁₅H₁₅NO: 225.1153 found: 225.1142; Anal. calcd for: C, 79.97; H, 6.71; N, 6.22. Found, C, 80.40; H, 6.52; N, 6.16.

6.4.1.4 Preparation of the Starting Material for Section 4.2.4

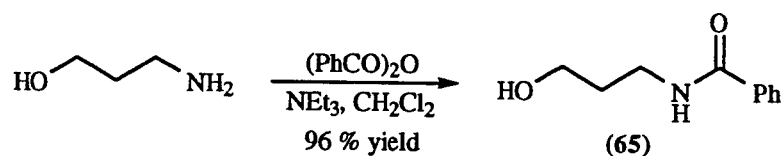
Preparation of N-(3-hydroxypropyl)benzamide (65).

N-(3-Hydroxypropyl)benzamide. As in reference 124, a 250 mL round bottomed flask was flame dried under nitrogen and allowed to cool. It was then charged with 100 mL of dry distilled dichloromethane, 14 mL (100 mmol) of triethylamine, and 7.6 mL (100 mmol) of 3-amino-1-propanol. This mixture was cooled to 0 °C and benzoic anhydride was added portionwise with stirring and cooling. After 15 minutes, TLC analysis indicated that the reaction was complete. Workup was effected by pouring the reaction mixture into a separatory funnel containing 300 mL of water and 400 mL of ethyl acetate. The organic layer was extracted 4 times with water, dried over anhydrous magnesium sulfate, filtered and concentrated. This procedure yielded 8.68 g (48.4 mmol) of the desired product which was pure by ^1H NMR and TLC analysis. The aqueous layer was back extracted three times with dichloromethane, and the combined dichloromethane layers were dried with anhydrous magnesium sulfate, filtered and concentrated. The benzoyl amide was obtained (8.47 g, 47.3 mmol) from this procedure in analytically (^1H NMR, TLC) pure form. The combined yield was 96% (see reference 124).

Preparation of 2-Phenyl-5, 6-dihydro-1, 3-thiazine-4H (66).

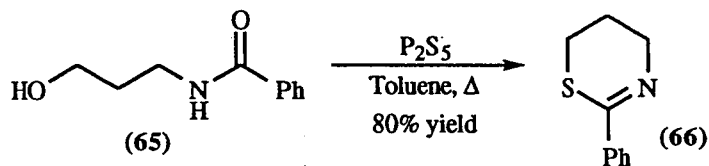

2-Phenyl-5, 6-dihydro-1, 3-thiazine-4H. As in reference 124, a 50 mL round bottomed flask was charged with 25 mL of dry distilled toluene and 2.66 g of amide **65** (16.33 mmol). Phosphorous pentasulfide (2 g, 9 mmol) was added portionwise to this solution and a reflux condenser attached. The reaction mixture was refluxed for 13.5 h, after which time the flask was removed from the oil bath and the reaction mixture was cooled to room temperature. Workup was effected by removal of toluene and heating the remaining intractable yellow solid to 100 °C with sodium hydroxide solution (10%, 25 mL). The basic solution was extracted with ether and the ether combined with the previously decanted toluene. The resulting solution was extracted three times with 10% HCl. The combined acid layers were neutralized with sodium hydroxide and extracted three times with ether. The ether extracts were dried over anhydrous magnesium sulfate, filtered and concentrated *in vacuo*. Purification of the resulting oil by chromatography gave a white solid in 80% yield (13.1 mmol, 2.3 g).

Preparation of 3-Methyl-2-phenyl-1, 3-thiazane (67).

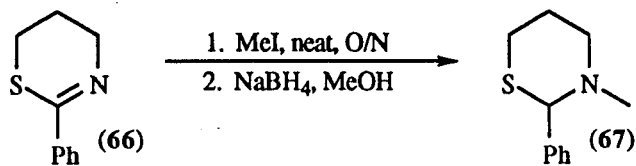

3-Methyl-2-phenyl-1, 3-thiazane. A 50 mL round bottomed flask was charged with thiazine **66** (526 mg, 2.97 mmol) and the system was flushed with nitrogen. Methyl

iodide (3 mL) was then added and the flask was covered with aluminum foil. The reaction mixture was stirred overnight in the dark, and in the morning there was only an off white precipitate suspended in a small amount of liquid (methyl iodide). The reaction was complete according to TLC analysis versus starting material. The reaction was worked up by rinsing the salt 3 times with 5 mL of dry ether and drying *in vacuo* (high vacuum). The white salt thus obtained was used directly in the next step.

Dry distilled methanol (10 mL) was added to the product from the previous reaction under nitrogen. Sodium borohydride (135 mg, 3 mmol) was added carefully (caution—vigorous evolution of hydrogen gas) and the reaction was allowed to continue overnight under nitrogen. The reaction was quenched by the careful addition of ether and water. The resulting mixture was partitioned between ether (150 mL) and water (200 mL). The aqueous layer was back extracted twice with 150 mL of ether and the combined organic layers were dried over anhydrous magnesium sulfate, filtered and concentrated *in vacuo*. The oil thus obtained was purified by chromatography on silica gel eluting with 30% ether in hexanes. Concentration of the appropriate fractions yielded the desired product (454 mg, 2.34 mmol) in 79% yield over 2 steps.

^1H NMR (200 MHz, CDCl_3) δ 7.50–7.22 (m, 5H, Ar-H), 4.88 (s, 1H, NCHS), 3.20–2.62 (m, 4H, NCH₂ and SCH₂), 2.14–1.60 (m, 2H, CH₂CH₂CH₂) ppm.; ^{13}C NMR (75 MHz, CDCl_3) δ 139.6, 128.3, 127.9, 56.5, 39.2, 29.9, 22.5 ppm.; IR neat, ν_{max} 2935, 1626, 1458, 1400, 1284, 1072, 1026, 711 cm^{-1} ; MS (m/z): 193 (M^+), 103, 70, 044 (100), 42; HRMS calcd for: $\text{C}_{11}\text{H}_{15}\text{NS}$: 193.0925, found: 193.0917.

Preparation of 3-[(ethoxy carbonyl)methyl]-2-phenyl-1, 3-thiazane (68).

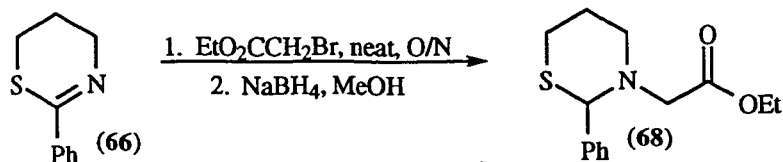

3-[(Ethoxy carbonyl)methyl]-2-phenyl-1, 3-thiazane. A 50 mL round bottomed flask was charged with thiazine **66** (745 mg, 4.2 mmol) and the system was flushed with nitrogen. Ethyl bromo acetate (3 mL, 25 mmol) was then added and the flask covered with aluminum foil. The reaction mixture was stirred overnight in the dark, and in the morning there was no precipitate. However, when stirring was stopped momentarily to remove an aliquot for TLC, and then restarted, a pale yellow solid precipitated immediately. TLC analysis indicated that a small amount of starting material remained, so the reaction mixture was warmed in an oil bath at 40 °C. After 1 hour, reaction was still not complete and so the temperature was increased to 55 °C for 1.5 hours. After this time TLC analysis indicated that the quaternization was complete. After cooling, the white salt that precipitated was washed 5 times with 10 mL of dry ether and dried *in vacuo* (high vacuum). The white salt thus obtained was used directly in the next step.

Dry distilled methanol (10 mL) was added to the product from the previous reaction under nitrogen. Sodium borohydride (160 mg, 4.2 mmol) was added carefully (caution-vigorous evolution of hydrogen gas) and the reaction was allowed to proceed overnight under nitrogen. The reaction was quenched by the careful addition of ether and water. The resulting mixture was partitioned between ether (300 mL) and water (300 mL). The aqueous layer was back extracted twice with 300 mL of ether and the combined organic layers were dried over anhydrous magnesium sulfate, filtered and concentrated *in vacuo*. The oil thus obtained (1 g) was purified by chromatography on silica gel with

15% ethyl acetate in hexanes as the eluant. Concentration of the appropriate fractions yielded the desired product (814 mg, 3.07 mmol) in 73% yield over 2 steps.

^1H NMR (200 MHz, CDCl_3) δ 7.55–7.52 (m, 2H, Ar-H), 7.33–7.24 (m, 2H, Ar-H), 5.35 (s, 3H, SCHN), 4.05 (q, $J = 7.1$ Hz, 2H, OCH_2CH_3), 3.55 (d, $J = 17.3$ Hz, 1H, NCHHCO₂Et), 3.30 (d, $J = 17.3$ Hz, 1H, NCHHCO₂Et), 3.23–2.81 (m, 4H, NCH₂ and SCH₂), 1.90–1.70 (m, 2H, CH₂CCH₂CH₂), 1.18 (t, $J = 7.1$ Hz, 3H, OCH_2CH_3) ppm.; ^{13}C NMR (75 MHz, CDCl_3) δ 170.9, 138.8, 128.3, 127.9, 127.3, 69.8, 60.2, 52.1, 51.8, 28.9, 21.5, 14.0 ppm.; IR neat, ν_{max} 2924, 1735, 1599, 1491, 1440, 1370, 1189, 1033, 731 cm^{-1} ; MS (m/z) 265 (M^+), 232, 192, 178 (100), 91, 42; HRMS calcd for $\text{C}_{14}\text{H}_{19}\text{NO}_2\text{S}$: 265.1136. Found: 265.1140

Attempted Preparation of 3-(benzoylmethyl)-2-phenyl-1, 3-thiazane (69).

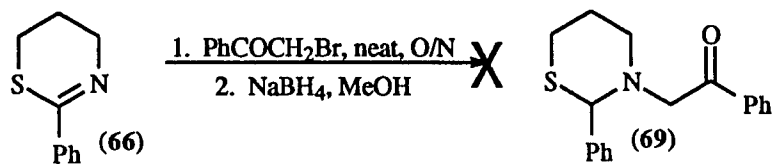

3-(Benzoylmethyl)-2-phenyl-1, 3-thiazane. A 50 mL round bottomed flask was charged with thiazine **66** (131 mg, 0.73 mmol) and the system was flushed with nitrogen. Purified (sublimation) bromo acetophenone (750 mg, 3.77 mmol) was then added along with 1 mL of dry distilled dichloromethane. The flask was covered with aluminum foil and the reaction mixture was stirred overnight in the dark. In the morning, TLC analysis indicated that a very small amount of starting material remained, but the reaction mixture was worked up. The dichloromethane was removed with a stream of dry nitrogen and the solid that remained was washed 5 times with 30 mL of pentane and once with a 1 : 1 mixture of pentane and dry ether. The resulting solid was dissolved in dry

dichloromethane and analyzed by TLC. This analysis indicated that some bromoacetophenone remained, and so the salt was precipitated and washed repeatedly with pentane/ether until TLC analysis indicated that all of the bromoacetophenone had been removed. The off white salt thus obtained was used directly in the next step.

Dry distilled methanol (10 mL) was added to the product from the previous reaction under nitrogen. Sodium borohydride (120 mg, 2.8 mmol) was added carefully (caution—vigorous evolution of hydrogen gas) and the reaction was allowed to proceed overnight under nitrogen. The reaction was quenched by the careful addition of ether and water. The resulting mixture was partitioned between ethyl acetate (100 mL) and water (100 mL). The aqueous layer was back extracted twice with 200 mL of ethyl acetate and the combined organic layers were dried over anhydrous magnesium sulfate, filtered and concentrated *in vacuo*. ^1H NMR analysis of the oil that resulted from this procedure was quite complicated and showed no evidence for the desired product. A similar reaction performed with one molar equivalent of sodium borohydride was also unsuccessful.

6.4.1.5 Preparation of the Starting Material for Section 4.2.5

Thionation of Benzamide

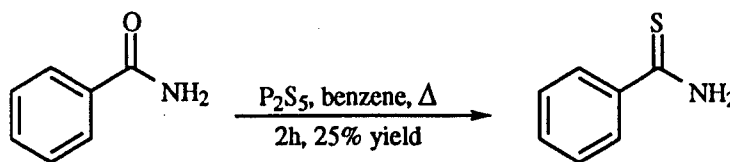

Thiobenzamide. Benzamide (20 g, 165 mmol) and sodium carbonate (17.5 g, 170 mmol) were suspended in 20 mL of dry distilled benzene and phosphorous pentasulfide (36.8 g, 170 mmol) was added. This mixture was refluxed for 1.5 hours under nitrogen,

after which time the benzene was decanted and the resulting solid residue was rinsed with ethyl acetate. The black residue was then stirred with a saturated bicarbonate solution (caution—CO₂ is evolved) and ethyl acetate until most of it had dissolved. Multiple extractions of this mixture with ethyl acetate yielded an orange red solution which was dried over anhydrous magnesium sulfate, filtered and concentrated *in vacuo*. The red oil obtained from evaporation of the ethyl acetate was further purified by silica gel chromatography with 20% ethyl acetate in hexanes as the eluant. Evaporation of the appropriate fractions yielded 5.44 g (39.6 mmol, 24%) of the thiobenzamide whose spectra matched those reported in the literature.^{128a}

Preparation of N-[(N, N-dimethylamino) methylidene] thiobenzamide (76).

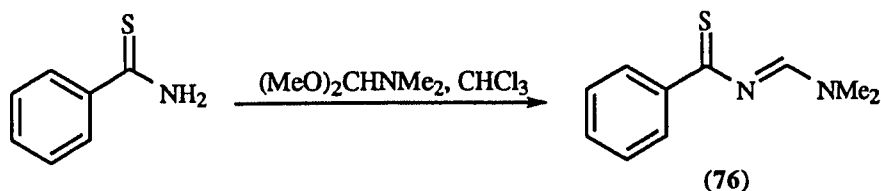

N-[(N, N-dimethylamino) methylidene] thiobenzamide. Thiobenzamide (4.18 g, 30.5 mmol) was dissolved in 120 mL of chloroform and the system was flushed with nitrogen. *N, N*-Dimethylformamide dimethylacetal (4.05 mL, 30.5 mmol) was added dropwise to the yellow solution, which became deep red. After stirring for one hour, TLC analysis indicated that the reaction was complete. Silica gel was added to the reaction mixture and the volatiles were removed *in vacuo*. The red solid that resulted was put on a silica gel column using 20% ethyl acetate in hexanes as the eluant. The red band was eluted and the solvent was removed *in vacuo*. This procedure yielded 3.05 g (15.8 mmol, 52%) of the pure product, whose spectra matched those given in reference 130.

Cycloaddition of Compound 76 with Methyl Vinyl Ketone.

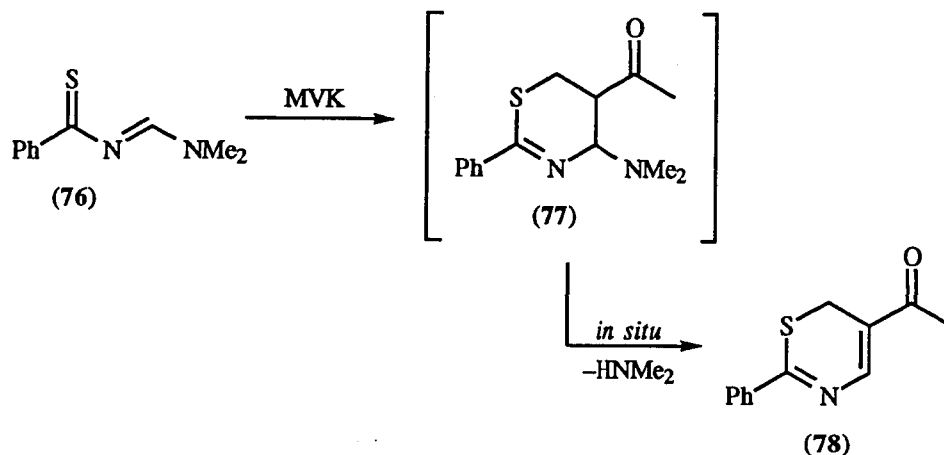

5-Acetyl-2-phenyl-6*H*-1,3-thiazine. *N*-[(*N,N*-dimethylamino) methylidene] thiobenzamide (3.05 g, 15.8 mmol) was dissolved in 150 mL of dry distilled benzene. Hydroquinone (150 mg, 1.4 mmol) was added to this solution along with freshly distilled methyl vinyl ketone (2 mL, 22 mmol). A reflux condenser was attached and the system was flushed with nitrogen. The red solution was refluxed for 1 hour, after which time, an additional 2 mL of distilled methyl vinyl ketone was added. After 2.5 hours, TLC analysis indicated that there was a 1 : 1 mixture of starting material and a less polar, yellow product. Therefore an additional 2 mL of methyl vinyl ketone was added along with 50 mg of hydroquinone. The red solution was refluxed until TLC analysis indicated that the reaction was complete (total reaction time = 6 hours). Workup was affected by removal of the volatiles *in vacuo* and purification of the resulting mixture by column chromatography using 25% ethyl acetate and hexanes to give the desired product in 76% yield (2.61 g, 12.0 mmol).

A similar reaction performed on 1.1 mmoles (210 mg of compound **(76)**) yielded 84% (200 mg, 0.92 mmol) of the desired product **(78)** after purification, whose spectra matched those given in reference 130.

Preparation of 5-acetyl-2-phenyl-3,6-dihydro-2H-1,3-thiazine (79).

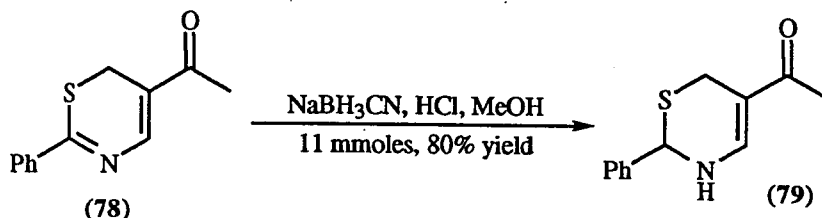

5-Acetyl-2-phenyl-3,6-dihydro-2H-1,3-thiazine. A 500 mL round bottomed flask was charged with 2.4 g (11.1 mmol) of thiazine **78**, along with 160 mL of 95% ethanol and 100 mL of THF. To this stirred solution was added sodium cyanoborohydride (770 mg, 12.2 mmol) followed by 10 mg of bromocresol green. The solution immediately turned green and concentrated HCl was added dropwise until the solution became yellow (ca. 20–30 drops). After 30 minutes, TLC analysis indicated that a small amount of starting material remained, and so a small amount of NaCNBH₃ was added (30 mg). After an additional 30 minutes, the reaction was worked up by removal of some of the ethanol *in vacuo* and extraction of the residue. This procedure yielded 1.95 g (8.9 mmol, 80%) of the desired product whose spectral data matched those described in reference 130.

Benzoylation of Enamine 79.

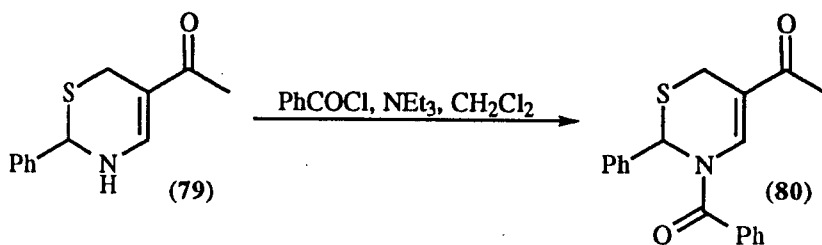

5-Acetyl-3-benzoyl-2-phenyl-3,6-dihydro-2H-1,3-thiazine. Compound **(79)**, (1.00 g, 4.6 mmol) was placed in a dry 100 mL round bottomed flask and suspended in

50 mL of dry distilled dichloromethane (enamine **79** was only sparingly soluble in dichloromethane even after heating) and the system was flushed with dry nitrogen. Triethylamine (0.7 mL, 5.04 mmol) was added followed by distilled benzoyl chloride (0.6 mL, 5.04 mmol). Approximately 10 minutes after the addition of the benzoyl chloride, the enamine was almost completely dissolved. TLC analysis indicated that one less polar compound had been produced, and some starting material remained. The reaction mixture was allowed to stir for an additional 1.5 hours under nitrogen, after which time it appeared as if the reaction had stopped. The reaction was worked up by partitioning between dichloromethane and distilled water. The aqueous layer was back extracted with dichloromethane several times and the combined organic layers washed with brine. Drying over anhydrous magnesium sulfate, filtration and evaporation of the volatiles *in vacuo* yielded an off white solid. The product was removed from the reaction mixture by triturating the solid with hot dichloromethane. The remaining starting material was precipitated by cooling of the solution thus obtained. The precipitate was filtered and rinsed with cold dichloromethane. This procedure allowed us to recover 217 mg of compound **79** (78% conversion). The benzoylated product was isolated by concentration of the dichloromethane washes. Purification by silica gel chromatography (eluant = 20% ethyl acetate in hexanes) gave 1.16 g of compound **80** (0.79 mmol, 53% yield, 67% based on 78% conversion).

A similar reaction performed with 2 equivalents of benzoyl chloride (0.97 mL, 8.32 mmol), 0.923 g of enamine **79** (4.16 mmol), 1.16 mL of triethylamine, (8.32 mmol) and 40 mL of dichloromethane yielded the desired product (**80**) in 95% yield (1.27 g, 3.94 mmol).

^1H NMR (200 MHz, CDCl_3) δ 8.23 (s, 1H, =CH), 7.68-7.22 (m, 10H, ArH), 6.67 (s, 1H, NCHS), 3.61, (dd, $J = 17.2, 1.3$ Hz, SCHH), 2.77 (dd, $J = 17.2, 1.8$ Hz, SCHH), 2.19 (s, 3H, COCH₃) ppm; ^{13}C NMR (75 MHz, CDCl_3) δ 194.9, 169.5, 138.1, 137.7, 131.8,

128.8, 128.6, 128.2, 128.0, 125.5, 56.9, 24.5, 19.3 ppm; IR neat, ν_{\max} 2961, 1672, 1619, 1493, 1447, 1352, 1260, 1226, 1182, 1131, 1047, 893, 727, 698 cm^{-1} ; MS (m/z): 323 (M^+), 218, 202, 186, 105 (100), 84; HRMS calcd. for $\text{C}_{19}\text{H}_{17}\text{NO}_2\text{S}$: 323.0980. Found: 323.1003; Anal. calcd. for: C, 70.56; H, 5.30; N, 4.33. Found C, 70.35; H, 5.08; N, 4.29.

Reduction of 5-Acetyl-2-phenyl-3,6-dihydro-2H-1,3-thiazine.

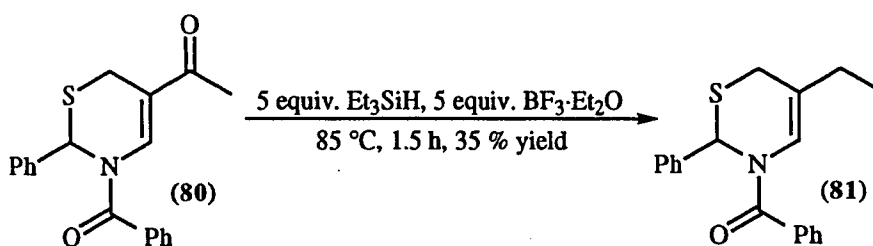

3-Benzoyl-5-ethyl-2-phenyl-3,6-dihydro-2H-1,3-thiazine. In a dry round bottomed flask was placed 641 mg (1.98 mmol) of enone **80**, along with boron trifluoride etherate (0.65 mL, 5.75 mmol) and triethylsilane (0.8 mL, 5.75 mmol). The flask was flushed with dry nitrogen and immersed in an oil bath at $85\text{ }^\circ\text{C}$ for 1.5 hours. During this time, the reaction was monitored periodically by TLC. After 1.5 hours, the starting material had disappeared, and so the reaction was worked up. The flask was removed from the oil bath and the reaction mixture was partitioned between ether and distilled water. The aqueous layer was then back extracted with ether and the combined organic layers were dried over anhydrous magnesium sulfate, followed by filtration and concentration. Purification of the resulting oil by silica gel chromatography yielded the desired product in 40% yield (242 mg, 0.78 mmol).

A similar reaction repeated on 0.877 mmoles (283 mg of compound **80**) yielded 35% of the desired product (94.7 mg, 0.31 mmol) after purification.

^1H NMR (200 MHz, CDCl_3) δ (at $-20\text{ }^\circ\text{C}$) 7.72–7.34 (m, 10H, Ar-H), 6.97 (s, 1H, SCHN), 6.66 (s, 1H, NCH=), 2.93–2.81 (m, 2H, SCH₂), 2.28–2.19 (m, 0.3 x 2H, =CCH₂CH₃), 2.12–1.97 (m, 0.7 x 2H, =CCH₂CH₃), 1.14 (t, $J = 7.3$ Hz, 0.3 x 3H, =CCH₂CH₃), 0.96 (t, $J = 7.3$ Hz, 0.7 x 3H, =CCH₂CH₃) ppm.; ^{13}C NMR (75 MHz, CDCl_3) δ (at $-20\text{ }^\circ\text{C}$) 168.6, 59.9 (minor), 54.3 (major), 29.5 (minor), 29.1 (major), 23.8 (minor), 23.5 (major), 12.7 (minor), 12.5 (major) ppm.; IR neat, ν_{max} 2965, 1647 (b), 1518, 1449, 1389, 1345, 1316, 1271, 1177, 1128, 1001, 698 cm^{-1} ; MS (m/z): 309 (M⁺), 204, 188, 172, 119, 105 (100); HRMS calc for C₁₉H₁₉NOS: 309.1187. Found: 309.1195.

6.4.2 Carbonylation Reactions

General Carbonylation Procedure

An autoclave, its glass liner and a magnetic stirring bar were dried in an oven and cooled in a dry box. The liner was charged with the catalyst and any co-catalyst or promoter. The heterocycle (1–2 mmol) and solvent were then added to the liner. An additional amount of solvent (from 2–9 mL) was placed in the autoclave prior to insertion of the liner. The gauge and gauge block assembly were attached. The CO line was flushed 3 times with CO and the system was also pressurized and flushed 3 times with CO, gradually increasing the pressure to the desired level. The system was then filled with CO and the autoclave placed in the center of an oil bath on a heater stirrer preset to the reaction temperature. After the appropriate time, the autoclave was removed from the oil bath and allowed to cool to room temperature. The excess gas was discharged and the system disassembled. The reaction mixture was analyzed by TLC, GC and NMR where

possible. Isolation of the products (if any) was accomplished by flash chromatography on silica gel.

6.4.2.1 Carbonylations Attempted in Section 4.2.1

Carbonylation of 1-Ethyl-1, 2, 3, 4-tetrahydroquinoline with $[Pd(CH_3CN)_4]^{2+}(BF_4^-)_2$ and $CuCl_2$.

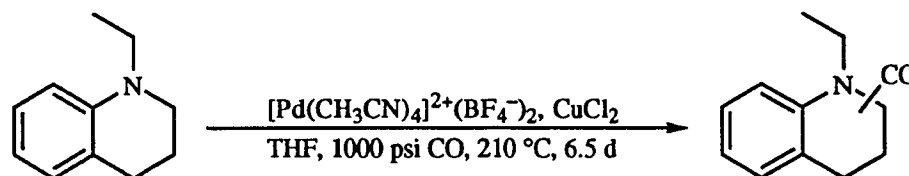

As in the general procedure, 1-ethyl-1, 2, 3, 4-tetrahydroquinoline (458 mg, 2.84 mmol), $[Pd(CH_3CN)_4]^{2+}(BF_4^-)_2$ (132 mg, 0.29 mmol) and $CuCl_2$ (593 mg, 4.3 mmol) were added to the autoclave liner along with 20 mL of THF. The liner was put into the autoclave and the system pressurized to 1000 psi with CO and heated to 200 °C for 6.5 days. After this time, the system was cooled and disassembled and the contents of the liner poured into a flask containing pentane which produced a fine red precipitate. The resulting suspension was filtered through celite and the filtrate concentrated. The celite was rinsed with THF and dichloromethane. Pentane was added to the red filtrate and the resulting suspension filtered through celite. The concentrated filtrates were analyzed by 1H NMR, ^{13}C NMR and GC. Extensive decomposition of the large amounts of starting amine made interpretation of the spectra difficult, but no products containing CO could be detected in the ^{13}C NMR. GC revealed two new compounds, both of which had a mass of 189 (GCMS) which corresponds to the insertion of CO. The major compound (ca. 10% by GC) had the same retention time as the amide resulting from carbonylation

of the acyclic C–N bond. The rest of the mass spectra however, did not match that of the authentic sample prepared by an alternative route, and so conclusive results cannot be reported.

Carbonylation of 1-Ethyl-1, 2, 3, 4-tetrahydroquinoline with $[Ru_3(CO)_{12}]$ and $Co_2(CO)_8$.

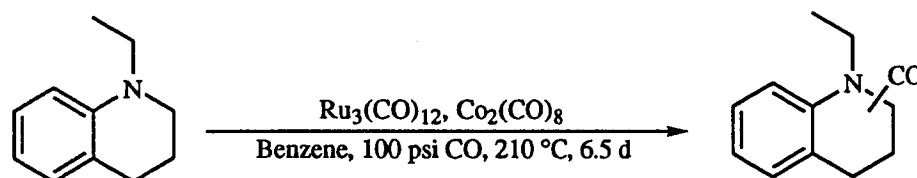

As in the general procedure, 1-ethyl-1, 2, 3, 4-tetrahydroquinoline (250 mg, 1.55 mmol), $Ru_3(CO)_{12}$ (99 mg, 0.16 mmol) and $Co_2(CO)_8$ (53 mg, 0.16 mmol) were added to the autoclave liner along with 5 mL of benzene. The liner was put into the autoclave and the system pressurized to 1000 psi with CO and heated to 200 °C for 6.5 days. After this time, the system was cooled and disassembled and the contents of the liner transferred to a round bottomed flask. Although analysis by 1H NMR, ^{13}C NMR showed only starting material, GC analysis revealed the presence of three compounds. According to GCMS, all had mass peaks which corresponded to the insertion of carbon monoxide. Since the yields of these compounds were so low, isolation and structure determination was not possible.

6.4.2.2 Carbonylations Attempted in Section 4.2.2

Attempted Carbonylation of 1-Ethyl-2-methoxy-1,2-dihydroquinazoline.

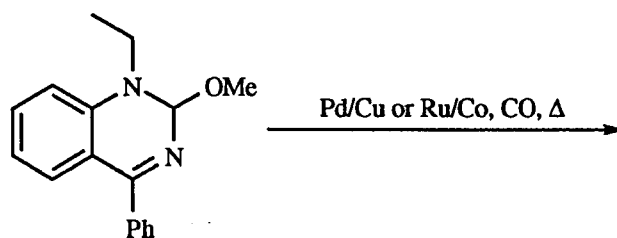

As in the general procedure, 1-ethyl-2-methoxy-1,2-dihydroquinazoline was treated with a variety of rhodium, palladium, cobalt and ruthenium complexes under extremely severe conditions, but in all cases only starting material was observed in the TLC or ^1H NMR of the crude reaction mixtures. Even under the Pd/Cu or Ru/Co conditions described above that gave an indication of carbonylation in the previous section there was no reaction.

6.4.2.3 Carbonylations Attempted in Section 4.2.3

Attempted Carbonylations of 1-(benzoylmethyl)-1,2,3,4-tetrahydroquinoline.

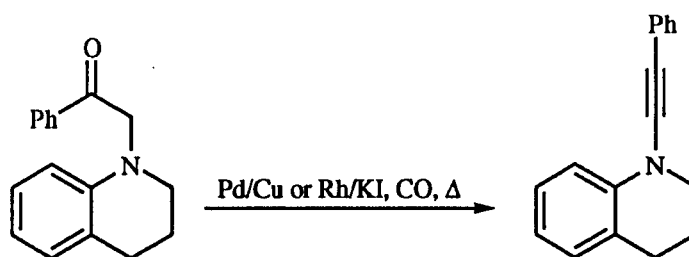

1-(Benzoylmethyl)-1, 2, 3, 4-tetrahydroquinoline (144 mg, 0.6 mmol), $[\text{Pd}(\text{CH}_3\text{CN})_4]^{2+}(\text{BF}_4^-)_2$ (25 mg, 0.06 mmol, 10%) and anhydrous CuCl_2 (95 mg, 0.7 mmol) were placed in a dry glass autoclave liner and rinsed in with 8 mL of dry distilled THF. THF (2 mL) was added to the autoclave and the liner inserted. The gauge and gauge block assembly were quickly attached and the autoclave rinsed with CO and pressurized to 900 psi. The autoclave was put in an oil bath and heated to 220 °C. After 11 hours, the autoclave was removed from the oil bath and cooled to room temperature. The excess gas was released and the autoclave disassembled. The contents of the liner were transferred to a round bottomed flask along with some silica gel and the volatiles removed *in vacuo*. The resulting oil was purified by flash chromatography eluting with 40% dichloromethane in hexanes and 1-phenylacetylene-1, 2, 3, 4-tetrahydroquinoline was isolated (28.5 mg, 0.122 mmol, 20%).

The same reaction was performed using $[\text{Rh}(\text{COD})\text{Cl}]_2$, KI. Thus, $[\text{Rh}(\text{COD})\text{Cl}]_2$ (23 mg, 0.12 mmol, 10%) and KI (19 mg, 0.12 mmol, 10%) were placed in a dry glass autoclave liner along with 2 mL of dry distilled THF. The liner was placed into the autoclave and the gauge and gauge block assembly attached. The system was flushed with CO and pressurized to 600 psi. The autoclave was heated to 40 °C for 12 hours, and then cooled and the pressure released. The autoclave was disassembled and 1-(benzoylmethyl)-1, 2, 3, 4-tetrahydroquinoline (288 mg, 1.2 mmol) was added to the autoclave along with an additional 2 mL of THF and the liner re-inserted into the autoclave. The system was reassembled and pressurized with 1200 psi of CO and heated to 180 °C for 2 days. After this time the autoclave was cooled and the excess gas released. The contents of the liner were purified by column chromatography which yielded 44 mg of the dehydrated acetylenic product (0.19 mmol, 16%).

^1H NMR (200 MHz, CDCl_3) δ 8.2-7.0 (m, 9H, Ar-H), 4.23-4.15 (m, 2H, NCH_2), 3.05-2.97 (m, 2H, NCH_2CH_2), 2.34-2.00 (m, 2H, $\text{NCH}_2\text{CH}_2\text{CH}_2$) ppm; ^{13}C NMR (75 MHz,

CDCl₃) δ 136.2, 134.9, 128.7, 126.8, 125.4, 123.7, 123.6, 122.0, 120.3, 118.9, 117.5, 116.5, 44.0, 24.5, 22.6 ppm; IR neat, ν_{\max} 2938, 1600, 1538, 1492, 1383, 1351, 1224, 778, 698 cm⁻¹; MS (m/z) 233 (M⁺); HRMS calcd for C₁₇H₁₅N: 233.1204. Found: 233.1199.

Attempted Carbonylation of 1-[(ethoxycarbonyl)methyl]-1, 2, 3, 4-tetrahydroquinoline.

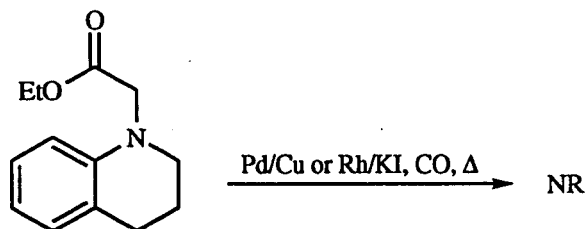

1-[(Ethoxycarbonyl)methyl]-1, 2, 3, 4-tetrahydroquinoline (123 mg, 0.56 mmol), [Pd(CH₃CN)₄]²⁺(BF₄⁻)₂ (25 mg, 0.06 mmol, 10%) and anhydrous CuCl₂ (93 mg, 0.7 mmol) were placed in a dry glass autoclave liner and rinsed in with 8 mL of dry distilled THF. THF (2 mL) was added to the autoclave and the liner inserted. The gauge and gauge block assembly were quickly attached and the autoclave rinsed with CO and pressurized to 1060 psi. The autoclave was put in an oil bath and heated to 200 °C. After 11 hours the autoclave was removed from the oil bath and cooled to room temperature. The excess gas was released and the autoclave disassembled. The contents of the liner were analyzed by TLC which showed that only starting material remained. The reaction was repeated on an identical scale, but left for 3 days. After this time, TLC analysis also indicated that there had been no reaction.

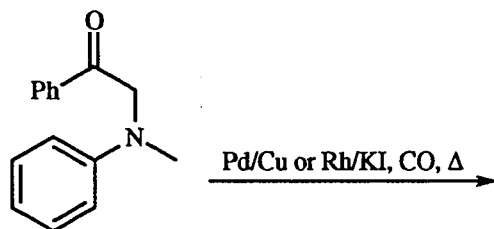
Attempted Carbonylation of 1-(benzoylmethyl)-1-methylaniline.

1-(Benzoylmethyl)-1-methylaniline (0.25 g, 1.29 mmol), $[\text{Pd}(\text{CH}_3\text{CN})_4]^{2+}(\text{BF}_4^-)_2$ (57 mg, 0.13 mmol, 10%) and anhydrous CuCl_2 (212 mg, 1.5 mmol) were placed in a dry glass autoclave liner and rinsed in with 10 mL of dry distilled THF. THF (2 mL) was added to the autoclave and the liner inserted. The gauge and gauge block assembly were quickly attached and the autoclave rinsed with CO and pressurized to 1000 psi. The autoclave was put in an oil bath and heated to 150 °C. After 16 hours, the autoclave was removed from the oil bath and cooled to room temperature. The excess gas was released and the autoclave disassembled. The contents of the liner were transferred to a round bottomed flask along with some silica gel and the volatiles removed *in vacuo*. The resulting oil was purified by flash chromatography and several fractions were isolated, none of which contained products resulting from insertion of CO.

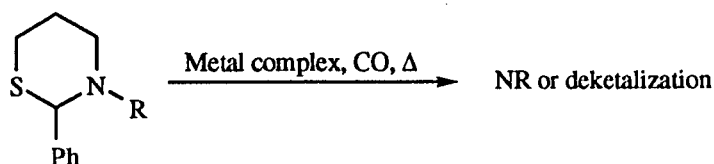
6.4.2.4 Carbonylations Attempted in Section 4.2.4*Attempted Carbonylation of 3-methyl-2-phenyl-1,3-thiazane.*

As in the general carbonylation procedure, 3-methyl-2-phenyl-1, 3-thiazane (100 mg, 0.52 mmol) was treated with $[\text{Rh}(\text{COD})\text{Cl}]_2$ (13 mg, 0.05 mmol) and KI (9 mg, 0.05 mmol) in benzene (4 mL) at 210 °C under 1000 psi of CO for 2.5 days. After this time, TLC and ^1H NMR analysis indicated that there was no reaction.

3-[(Ethoxycarbonyl)methyl]-2-phenyl-1, 3-thiazane also gave no reaction under the conditions described above. Treatment of this compound (105 mg, 0.4 mmol) with $[\text{Pd}(\text{CH}_3\text{CN})_4]^{2+}(\text{BF}_4^-)_2$ (35 mg, 0.04 mmol) and anhydrous CuCl_2 (108 mg, 0.8 mmol) under 1400 psi of CO at 200 °C for 5 days gave only small amounts of deketalization. (The crude reaction mixture contained a considerable amount of insoluble yellow precipitate which was also observed in the successful carbonylations of 1, 3-thiazolidines, see reference 55.)

3-benzyl-2-phenyl-1, 3-thiazane gave no reaction under the Rh/KI conditions, but the thiazane was completely hydrolyzed under the Pd/Cu conditions described above.

6.4.2.5 Carbonylations Attempted in Section 4.2.5

Attempted Carbonylations of 3-benzoyl-5-acetyl-2-phenyl-3, 6-dihydro-2H-1, 3-thiazine.

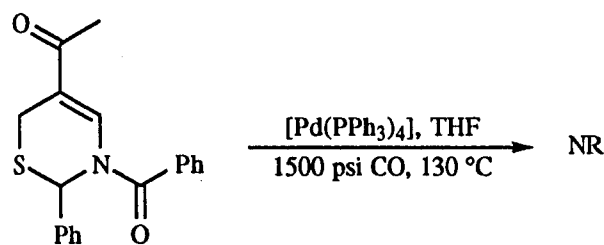

According to the general carbonylation procedure, compound (**80**) (55 mg, 0.17 mmol) was added to a dry autoclave liner along with tetrakis(triphenylphosphine) palladium (25 mg, 0.017 mmol, 10%) and distilled THF (2 mL). After treatment with 1500 psi of CO at 130 °C for 2 days, the autoclave was removed from the oil bath and disassembled. The contents of the liner were transferred to a round bottomed flask and the volatiles removed *in vacuo*. Analysis of the crude reaction mixture by ¹H NMR and TLC indicated that only the starting material remained. The reaction was repeated using palladium acetate and PPh₃, but no reaction was observed. Treatment with stoichiometric amounts of palladium was also ineffective.

Attempted Carbonylations of 3-benzoyl-5-ethyl-2-phenyl-3,6-dihydro-2H-1,3-thiazine.

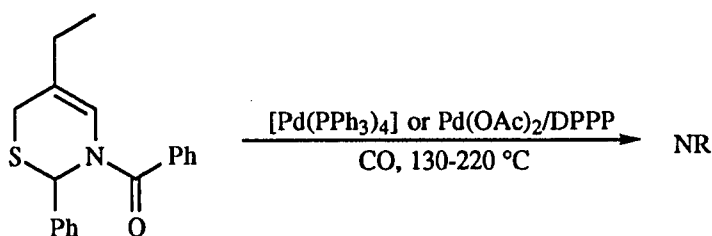

According to the general carbonylation procedure, compound (**81**) (40 mg, 0.13 mmol) was added to a dry autoclave liner along with tetrakis(triphenylphosphine) palladium (45 mg, 0.039 mmol, 30%) and toluene (2 mL). After treatment with 1000 psi of CO at 140 °C for 60h, the autoclave was removed from the oil bath and disassembled. The contents of the liner were transferred to a round bottomed flask and the volatiles removed *in vacuo*. Analysis of this mixture by ¹H and ¹³C NMR and TLC indicated that there had been no reaction.

The carbonylation was also attempted with catalytic or stoichiometric palladium acetate/DPPP (1/1) under 1000–1500 psi of CO as in the general carbonylation procedure at 140–200 °C, but there was no reaction under these conditions.

Carbonylation of 3-benzoyl-5-ethyl-2-phenyl-3,6-dihydro-2H-1,3-thiazine.

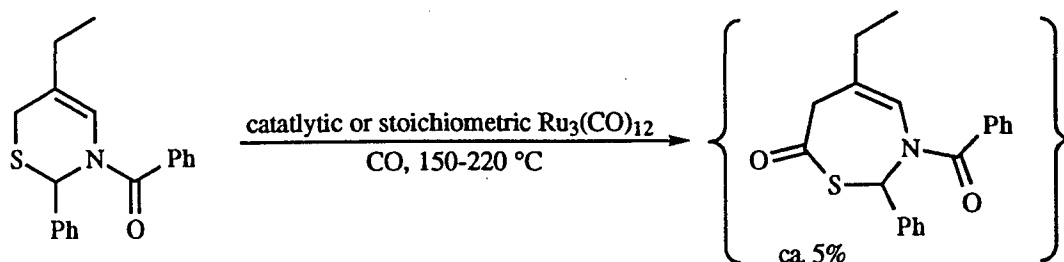

An experiment performed using 75 mg of thiazine **81** (0.24 mmol) and 31 mg of $\text{Ru}_3(\text{CO})_{12}$, (0.048 mmol, 20%) under similar conditions gave a small resonance in the carbonyl region of the ^{13}C nmr spectrum (189 ppm). TLC analysis indicated that one new compound had been produced and a large amount of the starting material remained. Using preparative TLC, 3 mg of an impure substance which contained a peak at 189 ppm was isolated, but further purification was not possible. The reaction was repeated using a stoichiometric amount of ruthenium and leaving the reaction for longer times, but the conversion could not be increased.

6.5 Experimental for Chapter 5

6.5.1 Preparation of the Starting Materials

Allylation of 4-Fluorothiophenol

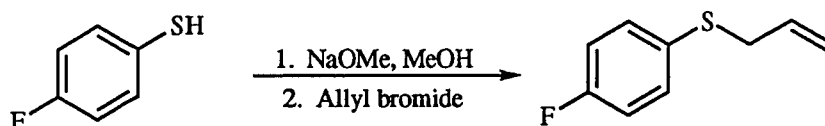

Allyl 4-fluorophenyl sulfide. Prepared by the method in given in reference 144 in 86% isolated yield (on a 19 mmol scale) after purification by Kugelrohr distillation. ^1H NMR (200 MHz, CDCl_3) δ 7.28–7.21 (m, 2H, Ar-H), 6.93–6.84 (m, 2H, Ar-H), 5.84–5.64 (m, 1H, CH=), 4.99–4.88 (m, 2H, =CH₂), 3.48 (dt, $J = 7.0, 1.1$ Hz, S-CH₂) ppm.; ^{13}C NMR (75 MHz, CDCl_3) δ 161.9 (d, $J_{\text{C-F}} = 246$ Hz), 133.5, 133.2 (d, $J_{\text{C-F}} = 8.1$ Hz), 130.5 (d, $J_{\text{C-F}} = 3.3$ Hz), 117.6, 115.8 (d, $J_{\text{C-F}} = 21.8$ Hz), 38.5 ppm.; IR neat, ν_{max} 1636, 1590, 1489, 1225, 1157, 1013, 921, 824 cm^{-1} ; MS (m/z) 168 (100, M⁺), 127, 100, 91; HRMS calcd for C₉H₉FS, 168.0364, found 168.0398.

Allylation of 4-Methoxythiophenol

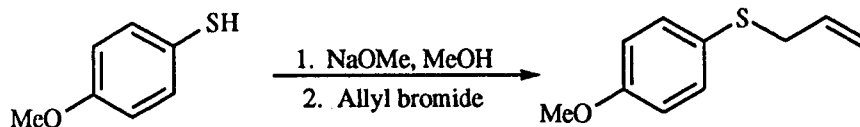

Allyl 4-methoxyphenyl sulfide. Prepared by the method given in reference 144 in 90% isolated yield (on a 16 mmol scale) after purification by Kugelrohr distillation. ^1H NMR

(200 MHz, CDCl_3) δ 7.24 (d, $J = 8.9$ Hz, 2H, Ar-H), 6.73 (d, $J = 8.9$ Hz, 2H, Ar-H), 5.81–5.64 (m, 1H, CH=), 4.93–4.83 (m, 2H, =CH₂), 3.69 (s, 3H, OCH₃), 3.33 (dt, $J = 8.3, 1.1$ Hz, S-CH₂) ppm.; ¹³C NMR (75 MHz, CDCl_3) δ 159.0, 133.98, 133.85, 125.7, 117.2, 114.3, 55.2, 39.2 ppm.; IR neat, ν_{max} 1634, 1592, 1462, 1285, 1243, 1176, 1032, 919, 824 cm^{-1} ; MS (m/z) 180 (M⁺), 139 (100), 100; HRMS calcd for C₁₀H₁₂OS, 180.0609, found 180.0589.

Allylation of Benzylmercaptan

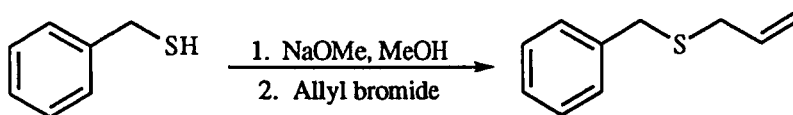

Allyl benzyl sulfide. Prepared by the general method in reference 144 in 70% yield (on a 16.8 mmol scale) after purification by Kugelrohr distillation. Further purification by column chromatography was necessary to remove traces of another unidentified compound. ¹H NMR (200 MHz, CDCl_3) δ 7.24–7.16 (m, 4H, Ar-H), 5.81–5.60 (m, 1H, CH=), 5.01–4.94 (m, 2H, =CH₂), 3.56 (s, 3H, CH₃), 2.94 (d, $J = 7.0$ Hz, S-CH₂) ppm.; ¹³C NMR (75 MHz, CDCl_3) δ 138.3, 134.1, 129.0, 128.6, 128.4, 127.9, 126.9, 117.3, 34.8, 34.0 ppm.; IR neat, ν_{max} 1634, 1592, 1462, 1285, 1243, 1176, 1032, 919, 824 cm^{-1} ; MS (m/z) 164 (M⁺), 122, 100, 91 (100); HRMS calcd for C₁₀H₁₂S, 164.0660, found 164.0662.

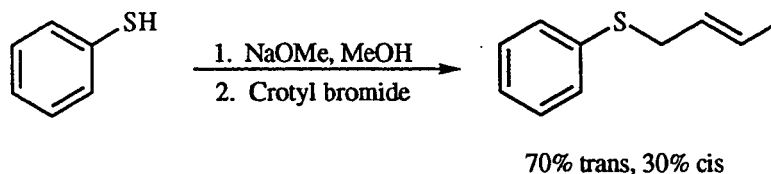
Allylation of Thiophenol with Crotyl Bromide

2-Butenyl phenyl sulfide (105). Prepared by the method in given in reference 144 in 58% isolated yield (on a 19.5 mmol scale) as a 70/30 E/Z mixture after purification by Kugelrohr distillation. Spectra match those given in reference 144.

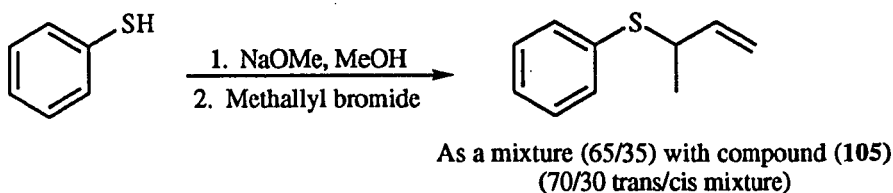
Allylation of Thiophenol with α -Methallyl Bromide

3-(1-Butenyl) phenyl sulfide (106). Prepared by the method given in reference 144 in 28% isolated yield (on a 19.5 mmol scale) along with 2-butenyl sulfide (35% of total sulfide, as a 70/30 E/Z mixture) after purification by Kugelrohr distillation. Spectra match those given in reference 144.

6.5.2 General Procedure for the Carbonylation Reactions

An autoclave, its glass liner and a magnetic stirring bar were dried in an oven and cooled in a dry box. The liner was charged with the catalyst (10% unless otherwise

noted), and any co-catalyst or promoter (10–20% unless otherwise noted). The allylsulfide (ca. 1 mmol) and solvent (ca. 4 mL) were then added to the liner. An additional amount of solvent (from 2–9 mL) was placed in the autoclave prior to insertion of the liner. The gauge and gauge block assembly were attached. The CO line was flushed 3 times with CO and the system was also pressurized and flushed 3 times with CO, gradually increasing the pressure to the desired level. The system was then filled with 1000 psi of CO and the autoclave placed in the center of an oil bath on a heater stirrer preset to the reaction temperature. After the appropriate time, the autoclave was removed from the oil bath and allowed to cool to room temperature. The excess gas was discharged and the system disassembled. The internal standard was added and the contents of the liner transferred to a round bottomed flask. The volatiles were removed *in vacuo* and the yield and conversion measured by ^1H NMR. These yields and conversions are accurate to $\pm 5\%$. In some cases the products were then isolated by column chromatography and/or recycling HPLC using a gel permeation column. After isolation, NMR analyses were performed and the spectra compared with the literature where possible.¹⁴⁵

6.5.2.1 Carbonylation of Allyl 4-Methylphenyl Sulfide with $[\text{Pd}(\text{PPh}_3)_4]$.

Following the general procedure, tetrakis(triphenylphosphine) palladium (246 mg, 0.21 mmol, 20%) was placed in a dry autoclave liner followed by allyl 4-methylphenyl sulfide (175 mg, 1.07 mmol) and 5 mL of dry distilled toluene. After assembly of the autoclave and pressurizing to 1000 psi of CO, the reaction was allowed to proceed at 140°C for 44h. The ^1H NMR yield based on added internal standard was determined to be 53% (**85**) with 75% conversion. The product of isomerization of the allyl sulfide (**86**) was also detected in the crude ^1H NMR spectrum (19%)—Table 15, entry 1.

A similar reaction, performed in THF, using 77 mg (0.07 mmol, 20%) of $[\text{Pd}(\text{PPh}_3)_4]$ and 55mg (0.33 mmol) of allyl 4-methylphenyl sulfide, yielded 46% of the desired product (**85**) and 30% isomerization (**86**) (84% conversion)–Table 15, entry 2.

The carbonylation of allyl 4-methylphenyl sulfide (80 mg, 0.5 mmol), carried out in 4 mL of toluene using $[\text{Pd}(\text{PPh}_3)_4]$ (112 mg, 0.097 mmol, 20%), gave 62% of (**85**), 26% of (**86**) and 91% conversion after 72 hours at 10 °C–Table 15, entry 3.

A similar reaction performed at 100 °C using 10% $[\text{Pd}(\text{PPh}_3)_4]$ (106 mg, 0.9 mmol) and 151 mg (0.92 mmol) of allyl 4-methylphenyl sulfide afforded 64% of the ester (**85**), 11% of the isomerized enol thioether (**86**) and 100% conversion after 100 hours–Table 15, entry 4.

When the same reaction was performed at 140 °C for 72 hours with 10% $[\text{Pd}(\text{PPh}_3)_4]$ (112 mg, 0.097 mmol) and 159 mg of allyl 4-methylphenyl sulfide, (0.97 mmol), (**85**) was obtained in 61% yield, along with 6% isomerization (**86**)–Table 15, entry 5.

6.5.2.2 Carbonylation of Allyl 4-Methylphenyl Sulfide with $\text{Pd}(\text{OAc})_2$.

Following the general procedure, palladium acetate (10%) was added to the autoclave liner along with 2 equivalents (20%) of DPPP. Allyl 4-methylphenyl sulfide was then added followed by 4 mL of toluene. After treatment with 1000 psi of CO at 140 °C for 24 hours, no reaction was observed–Table 16, entry 1.

Following the general procedure, palladium acetate (246 mg, 0.21 mmol, 20%) was placed in a dry autoclave liner along with 1 equivalent, (10%) of DPPP followed by allyl 4-methylphenyl sulfide (175 mg, 1.07 mmol) and 5 mL of dry distilled toluene. After assembly of the autoclave and pressurizing to 1000 psi of CO, the reaction was allowed to proceed at 140°C for 44h. The ^1H NMR yield (**85**) based on added internal

standard was determined to be 73% with 87% conversion. The product of isomerization of the allyl sulfide (**86**) was not detected in the crude ^1H NMR spectrum—Table 16, entry 2.

A similar reaction was performed with two equivalents of triphenylphosphine (63 mg, 0.24 mmol), 10% palladium acetate (27 mg, 0.12 mmol) and 197 mg (1.05 mmol) of allyl 4-methylphenyl sulfide and yielded 44% of the desired thioester (**85**) by ^1H NMR and none of the isomerized product (**86**) was detected (56% conversion)—Table 16, entry 3.

No reaction was observed when two equivalents of tricyclohexylphosphine were used in combination with 10% palladium acetate—Table 16, entry 4.

No reaction was observed when palladium acetate was used without any additives or in the presence of 5 equivalents of sodium acetate—Table 16, entries 5 and 6.

6.5.2.3 Attempted Carbonylations of Allyl 4-Methylphenyl Sulfide with Miscellaneous Catalysts.

All of the following reactions employ the general carbonylation procedure outlined at the beginning of this section (6.5).

- (a) $[\text{Rh}(\text{COD})\text{Cl}]_2$ (10%) was added to the autoclave liner along with 20% KI. Allyl 4-methylphenyl sulfide was then added followed by 4 mL of toluene. After heating at 130 °C under 1000 psi of CO for 24 hours, no reaction was observed.
- (b) Allyl 4-methylphenyl sulfide (127 mg, 0.77 mmol) was treated with ruthenium carbonyl (50 mg, 0.077 mmol, 10%) and dicobalt octacarbonyl (27 mg, 0.077 mmol, 10%) in 3 mL of toluene. After reaction under 1000 psi of CO at 140 °C for 45 hours, 7% of the unconjugated thioester (**87**) was observed by ^1H NMR with 59% conversion.

- (c) The carbonylation of allyl 4-methylphenyl sulfide was not catalyzed by bis(benzonitrile)-1, 3-bis(diphenylphosphino) propane palladium bis (tetrafluoroborate) (6%) in the presence of 1 equivalent (6%) of DPPP in 4 mL of toluene after treatment with 1000 psi of CO at 140 °C for 24 hours.
- (d) Bis(triphenylphosphine)nickel dicarbonyl (100%, 700 mg, 1.09 mmol) also did not catalyze the carbonylation of allyl 4-methylphenyl sulfide (179 mg, 1.09 mmol) in 4 mL of toluene after treatment with 1000 psi of CO at 140 °C for 24 hours.
- (e) Allyl 4-methylphenyl sulfide (151 mg, 0.96 mmol), bis(1, 2-bis(diphenylphosphino) ethane) nickel dichloride (20%, 106 mg, 0.2 mmol) and 4 mL of toluene were heated to 140 °C under 1000 psi of CO for 24 hours, but there was no reaction.
- (f) Molybdenum hexacarbonyl (10%) was added to the autoclave liner along with allyl 4-methylphenyl sulfide and 4 mL of toluene. After treatment with 1000 psi of CO at 140 °C for 48 hours, no reaction was observed.

6.5.2.4 Carbonylation Reactions of Allyl 4-Methylphenyl Sulfide with Ruthenium and Iridium Catalysts.

All of the following reactions employ the general carbonylation procedure outlined at the beginning of this section (6.5).

- (a) Tris(triphenylphosphine)ruthenium dichloride (103 mg, 0.11 mmol, 10%) and 1, 5-cyclooctadiene iridium chloride (36 mg, 0.11 mmol, 10%) were added to the autoclave liner along with allyl 4-methylphenyl sulfide (177 mg, 1.1 mmol) followed by 4 mL of toluene. After reaction under 1000 psi of CO at 140 °C for 42 hours, 7% of the

unconjugated thioester (**87**) was observed along with 12% conversion of starting materials—Table 17, entry 1.

(b) Tris(triphenylphosphine)ruthenium dichloride (103 mg, 0.11 mmol, 10%) and iridium (I) carbonyl chloride (34 mg, 0.11 mmol, 10%) were added to the autoclave liner along with allyl 4-methylphenyl sulfide (177 mg, 1.1 mmol) followed by 4 mL of toluene. After reaction under 1000 psi of CO at 140 °C for 42 hours, 16% of the unconjugated thioester (**87**) was observed along with 20% conversion of starting materials—Table 17, entry 2.

(c) Ruthenium carbonyl (10%) and iridium (I) carbonyl chloride (10%) were added to the autoclave liner along with allyl 4-methylphenyl sulfide followed by 4 mL of toluene. After treatment with 1000 psi of CO at 140 °C for 45 hours, no reaction was observed although there was a 51% conversion of starting materials—Table 17, entry 3.

(d) Ruthenium carbonyl (63 mg, 0.1 mmol, 10%) and iridium carbonyl (110 mg, 0.1 mmol, 10%) were added to the autoclave liner along with allyl 4-methylphenyl sulfide (163 mg, 0.99 mmol) followed by 4 mL of toluene. After reaction under 1000 psi of CO at 100 °C for 60 hours, 23% of the thioester (**87**) was observed along with 55% conversion—Table 17, entry 4.

(e) A similar experiment performed at 140 °C for 45 hours gave 18% yield and 30% conversion—Table 17, entry 5.

(f) Tris(triphenylphosphine)ruthenium dichloride (10%) and iridium carbonyl (10%) were added to the autoclave liner along with allyl 4-methylphenyl sulfide followed by 4 mL of toluene. After treatment with 1000 psi of CO at 120 °C for 45 hours, there was no reaction (2% conversion of starting materials)—Table 17, entry 6.

(g) Ruthenium carbonyl (67 mg, 0.11 mmol, 10%) and iridium carbonyl (116 mg, 0.11 mmol, 10%) were added to the autoclave liner along with allyl 4-methylphenyl sulfide (172 mg, 1.05 mmol) followed by 4 mL of toluene. After reaction under 1000 psi

of CO at 120 °C for 65 hours, 34% of the thioester (87) was observed along with 55% conversion—Table 17, entry 7.

(h) Ruthenium carbonyl (10%) and bis (triphenylphosphine) iridium chloro carbonyl (10%) were added to the autoclave liner along with allyl 4-methylphenyl sulfide followed by 4 mL of toluene. After treatment with 1000 psi of CO at 100 °C for 45 hours, there was no reaction although 35% conversion of starting material was observed—Table 17, entry 8.

(i) Ruthenium carbonyl (45 mg, 0.07 mmol, 10%) and iridium carbonyl (80 mg, 0.07 mmol, 10%) were added to the autoclave liner along with allyl 4-methylphenyl sulfide (119 mg, 0.73 mmol) followed by 3 mL of THF. After reaction under 1000 psi of CO at 100 °C for 69 hours, 24% of the thioester (87) was observed along with 65% conversion—Table 17, entry 9.

(j) Tris(triphenylphosphine)ruthenium dichloride (101 mg, 0.10 mmol, 10%) and iridium (I) carbonyl chloride (33 mg, 0.10 mmol, 10%) were added to the autoclave liner along with allyl 4-methylphenyl sulfide (173 mg, 1.05 mmol) followed by 4 mL of toluene. After reaction under 1000 psi of CO at 140 °C for 69 hours, 27% of the unconjugated thioester (87) was observed along with 36% conversion of starting materials—Table 17, entry 10.

(k) Ruthenium carbonyl (66 mg, 0.10 mmol, 10%) was added to the autoclave liner along with allyl 4-methylphenyl sulfide (168 mg, 1.02 mmol) followed by 4 mL of toluene. After reaction under 1000 psi of CO at 140 °C for 45 hours, 34% of the thioester (87) was observed along with 47% conversion—Table 17, entry 11.

(l) Iridium carbonyl (10%) was added to the autoclave liner along with allyl 4-methylphenyl sulfide followed by 4 mL of toluene. After treatment with 1000 psi of CO at 140 °C for 45 hours, there was no reaction and a 7% conversion of starting material was observed—Table 17, entry 12.

- (m) Ruthenium carbonyl (60 mg, 0.09 mmol, 10%) was added to the autoclave liner along with allyl 4-methylphenyl sulfide (155 mg, 0.94 mmol) followed by 3 mL of toluene. After reaction under 1000 psi of CO at 140 °C for 72 hours, 50% of the thioester (**87**) was observed along with 65% conversion—Table 17, entry 13.
- (n) Ruthenium carbonyl (62 mg, 0.1 mmol, 10%) was added to the autoclave liner along with allyl 4-methylphenyl sulfide (158 mg, 0.96 mmol) followed by 4 mL of toluene. After reaction under 1000 psi of CO at 140 °C for 24 hours, none of the desired thioester was detected, but 17% of the enol thioether (**86**), and 66% conversion of starting material were observed—Table 17, entry 14.
- (o) Tris(triphenylphosphine)ruthenium dichloride (10%) was added to the autoclave liner along with allyl 4-methylphenyl sulfide followed by 4 mL of toluene. After reaction under 1000 psi of CO at 140 °C and there was no reaction after 72 hours—Table 17, entry 15.

6.5.2.5 Carbonylation Reactions with Pd(OAc)₂/DPPP and Ru₃(CO)₁₂

Palladium Catalyzed Carbonylation of Phenyl allyl Sulfide

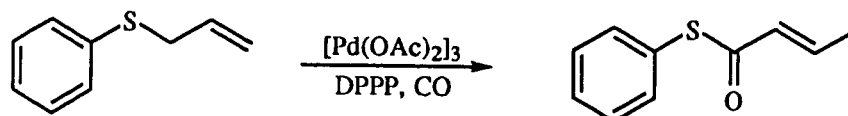

(E)-2-Butenoic acid *S*-phenyl ester (**88**). Following the general procedure, palladium acetate (45 mg, 0.199 mmol, 10%) and 1, 3-bis (diphenylphosphino) propane (82 mg, 0.199 mmol, 10%) were placed in a dry autoclave liner followed by allyl phenyl sulfide (299 mg, 1.99 mmol) and 8 mL of dry distilled toluene. After assembly of the autoclave and pressurizing to 1000 psi of CO, the reaction was allowed to proceed at 140°C for

44h. The ^1H NMR yield based on added internal standard was determined to be 69% with 92% conversion. Purification by column chromatography on silica gel eluting with 5% ethyl acetate in hexanes yielded the pure product (see reference 145, spectra not given). (Table 18, entry 1)

^1H NMR (200 MHz, CDCl_3) δ 7.36–7.30 (m, 5H, Ar-H), 6.90 (dq, $J = 15.4, 6.9$ Hz, 1H, =CHCH₃), 6.11 (dq, $J = 15.4, 1.7$ Hz, 1H, COCH=), 1.82 (dd, $J = 6.9, 1.7$ Hz, CH₃) ppm.; ^{13}C NMR (75 MHz, CDCl_3) δ 187.8, 142.1, 134.7, 129.4, 129.3, 129.1, 18.1 ppm.; IR neat, ν_{max} 1685, 1636, 1478, 1440, 1285, 1154, 1040, 961, 910, 800, 739, 689 cm^{-1} ; MS (m/z) 178 (M^+), 109, 100, 88, 70 (100); HRMS calcd for $\text{C}_{10}\text{H}_{10}\text{OS}$, 178.0452, found 178.0430.

Ruthenium Catalyzed Carbonylation of Allyl phenyl Sulfide

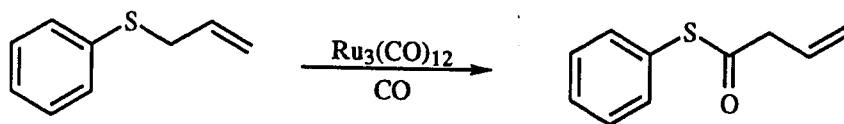

3-Butenoic acid *S*-phenyl ester (89). Following the general procedure, ruthenium carbonyl (118 mg, 0.18 mmol, 10%) and allyl phenyl sulfide (276 mg, 1.84 mmol) were placed in a dry autoclave liner followed by 7 mL of dry distilled toluene. After assembly of the autoclave and pressurizing to 1000 psi of CO, the reaction was allowed to proceed at 140°C for 72 h. The ^1H NMR yield based on added internal standard was determined to be 33% with 55% conversion. Purification by column chromatography on silica gel yielded 98 mg (0.55 mmol, 30%) of the pure product. (Table 18, entry 2)

^1H NMR (200 MHz, CDCl_3) δ 7.3 (br s, 5H, Ar-H), 5.98–5.77 (m, 1H, $\text{CH}_2\text{CH}=\text{}$), 5.22–5.13 (m, 2H, $=\text{CH}_2$), 3.31 (dt, $J = 7.1, 1.3$ Hz, 2H, COCH_2) ppm.; ^{13}C NMR (75 MHz, CDCl_3) δ 195.1, 134.5, 130.0, 129.6, 129.4, 129.2, 120.1, 48.1 ppm.; IR neat, ν_{max} 1704, 1656, 1638, 1477, 1440, 1277, 998, 746, 689 cm^{-1} ; MS (m/z) 178 (M^+), 137, 110 (100), 91, 77; HRMS calcd for $\text{C}_{10}\text{H}_{10}\text{OS}$, 178.0452, found 178.0458.

Palladium Catalyzed Carbonylation of Allyl 4-methylphenyl Sulfide

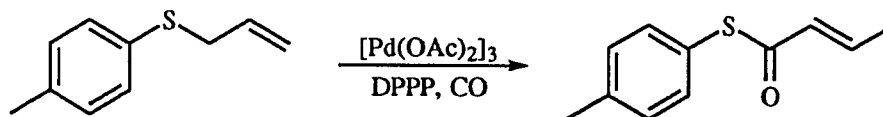

(E)-2-Butenoic acid S-(4-methylphenyl) ester (85). Following the general procedure, palladium acetate (22 mg, 0.098 mmol, 10%) and 1, 3-bis (diphenylphosphino) propane (41 mg, 0.098 mmol, 10%) were placed in a dry autoclave liner followed by allyl 4-methylphenyl sulfide (161 mg, 0.98 mmol) and 4 mL of dry distilled toluene. After assembly of the autoclave and pressurizing to 1000 psi of CO, the reaction was allowed to proceed at 140°C for 44h. The ^1H NMR yield based on added internal standard was determined to be 73% with 87% conversion. Purification by flash chromatography on silica gel with hexanes as eluant yielded 85% of the product which was slightly impure by ^1H NMR. Further purification by recycling HPLC yielded 93 mg (0.48 mmol, 50%) of the pure product. (Table 18, entry 3)

^1H NMR (200 MHz, CDCl_3) δ 7.23 (d, $J = 8.2$ Hz, 2H, Ar-H), 7.12 (d, $J = 8.2$ Hz, 2H, Ar-H), 6.89 (dq, $J = 15.4, 6.9$ Hz, 1H, $=\text{CH}-\text{CH}_3$), 6.11 (dq, $J = 15.4, 1.7$ Hz, 1H, $\text{CO}-\text{CH}=\text{}$), 2.28 (s, 3H, Ar- CH_3), 1.82 (dd, $J = 6.9, 1.7$ Hz, 3H, $=\text{CHCH}_3$) ppm.; ^{13}C NMR (75 MHz, CDCl_3) δ 188.3, 141.8, 139.6, 129.9, 129.3, 124.0, 21.3, 18.0 ppm.; IR neat,

ν_{\max} 1681, 1637, 1493, 1284, 1039, 805 cm^{-1} ; MS (m/z) 192 (M^+), 123, 91, 69 (100), 41; HRMS calcd for $\text{C}_{11}\text{H}_{12}\text{OS}$, 192.0609, found 192.0622. Anal. calcd for $\text{C}_{11}\text{H}_{12}\text{OS}$: C, 68.71; H, 6.29. Found: C, 68.62; H, 6.09

Ruthenium Catalyzed Carbonylation of Allyl 4-methylphenyl Sulfide

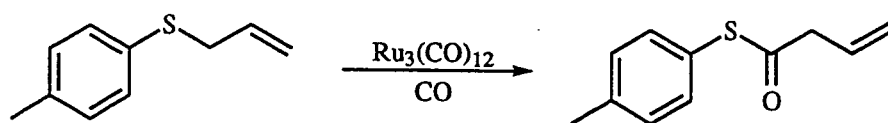

3-Butenoic acid S-(4-methylphenyl) ester (87). Following the general procedure, ruthenium carbonyl (60 mg, 0.09 mmol, 10%) and allyl 4-methylphenyl sulfide (155 mg, 0.94 mmol) were placed in a dry autoclave liner followed by 4 mL of dry distilled toluene. After assembly of the autoclave and pressurizing to 1000 psi of CO, the reaction was allowed to proceed at 140°C for 72 h. The ^1H NMR yield based on added internal standard was determined to be 50% with 65% conversion. Purification by recycling HPLC chromatography yielded the pure product. (Table 18, entry 4)

^1H NMR (200 MHz, CDCl_3) δ 7.21 (d, $J = 8.4$ Hz, 2H, Ar- H), 7.12 (d, $J = 8.4$ Hz, 2H, Ar- H), 5.99–5.78 (m, 1H, $\text{CH}=\text{CH}_2$), 5.22–5.13 (m, 2H, $\text{CH}=\text{CH}_2$), 3.30 (dt, $J = 6.8, 1.2$ Hz, 2H, COCH_2), 2.28 (s, 3H, CH_3) ppm.; ^{13}C NMR (75 MHz, CDCl_3) δ 195.6, 139.7, 134.4, 130.0, 129.7, 124.0, 119.9, 48.0, 21.3 ppm.; IR neat, ν_{\max} 1703, 1639, 1493, 1299, 996, 807 cm^{-1} ; MS (m/z) 192 (M^+), 124 (100), 91, 69, 41; HRMS calcd for $\text{C}_{11}\text{H}_{12}\text{OS}$, 192.0609, found 192.0621.

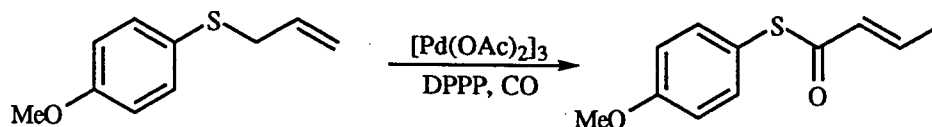
Palladium Catalyzed Carbonylation of Allyl 4-methoxyphenyl Sulfide

(E)-2-Butenoic acid *S*-(4-methoxyphenyl) ester (90). Following the general procedure, palladium acetate (24 mg, 0.105 mmol, 10%) and 1, 3-bis (diphenylphosphino) propane (44 mg, 0.105 mmol, 10%) were placed in a dry autoclave liner followed by allyl 4-methoxyphenyl sulfide (190 mg, 1.05 mmol) and 4 mL of dry distilled toluene. After assembly of the autoclave and pressurizing to 1000 psi of CO, the reaction was allowed to proceed at 140°C for 45h. ¹H NMR yield and conversion were not calculated due to interference of the OCH₃ signal with the Ph₂CH₂ signal. Purification by flash chromatography on silica gel with 5% ethyl acetate in hexanes as eluant yielded 136 mg (0.65 mmol, 62%) of the pure product. (Table 18, entry 5)

¹H NMR (200 MHz, CDCl₃) δ 7.24 (d, *J* = 8.9 Hz, 2H, Ar-*H*), 6.97–6.79 (m, 3H, Ar-*H*, =CHCH₃), 6.10 (dq, *J* = 15.4, 1.7 Hz, 1H, COCH=), 3.72 (s, 3H, OCH₃), 1.81 (dd, *J* = 6.9, 1.7 Hz, 3H, =CHCH₃) ppm.; ¹³C NMR (75 MHz, CDCl₃) δ 188.8, 160.5, 141.7, 136.2, 129.2, 118.2, 114.8, 55.3, 18.0 ppm.; IR neat, ν_{max} 1680, 1636, 1593, 1494, 1289, 1249, 1176, 1154, 1034, 908, 800 cm⁻¹; MS (*m/z*) 208 (100, M⁺), 140, 125, 100; HRMS calcd for C₁₁H₁₂O₂S, 208.0558, found 208.0552. Anal. calcd for C₁₁H₁₂O₂S: C, 63.43; H, 5.81. Found: C, 63.28; H, 5.96

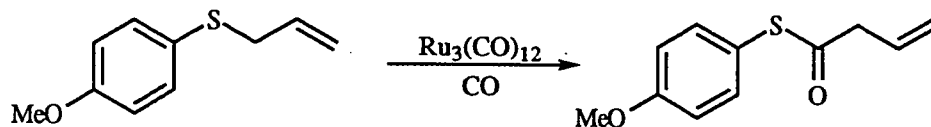
Ruthenium Catalyzed Carbonylation of Allyl 4-methoxyphenyl Sulfide

3-Butenoic acid S-(4-methoxyphenyl) ester (91). Following the general procedure, ruthenium carbonyl (63 mg, 0.1 mmol, 10%) and allyl 4-methoxyphenyl sulfide (177 mg, 0.98 mmol) were placed in a dry autoclave liner followed by 4 mL of dry distilled toluene. After assembly of the autoclave and pressurizing to 1000 psi of CO, the reaction was allowed to proceed at 120°C for 72 h. The ^1H NMR yield based on added internal standard could not be determined because the OCH_3 signal interfered with the Ph_2CH_2 signal. Purification by silica gel chromatography using hexanes and ethyl acetate as the eluants afforded 80 mg (0.38 mmol, 39%) of the pure product—(Table 18, entry 7). Another reaction performed at 140 °C using 89 mg of $\text{Ru}_3(\text{CO})_{12}$ and 245 mg of allyl 4-methoxyphenyl sulfide yielded 106 mg (0.51 mmol, 37%) of the desired product after purification by recycling HPLC. (Table 18, entry 6)

^1H NMR (200 MHz, CDCl_3) δ 7.22 (d, $J = 8.9$ Hz, Ar-H), 6.83 (d, $J = 8.9$ Hz, Ar-H), 5.94–5.77 (m, 1H, $\text{CH}_2=\text{CHCH}_2$), 5.21–5.12 (m, 2H, $=\text{CH}_2$), 3.72 (s, 3H, $-\text{OCH}_3$), 3.28 (dt, $J = 7.0, 1.3$ Hz, COCH_2) ppm.; ^{13}C NMR (75 MHz, CDCl_3) δ 196.2, 160.6, 136.0, 129.7, 119.9, 118.2, 114.8, 55.2, 47.8 ppm.; IR neat, ν_{max} 1701, 1638, 1593, 1574, 1495, 1462, 1292, 1249, 1178, 1113; 1029, 997, 921, 828, 643 cm^{-1} ; MS (m/z) 208 (M^+), 140 (100), 119; HRMS calcd for $\text{C}_{11}\text{H}_{12}\text{O}_2\text{S}$, 208.0558, found 208.0543; Anal. calcd for $\text{C}_{11}\text{H}_{12}\text{O}_2\text{S}$: C, 63.43; H, 5.81. Found: C, 63.63; H, 6.11.

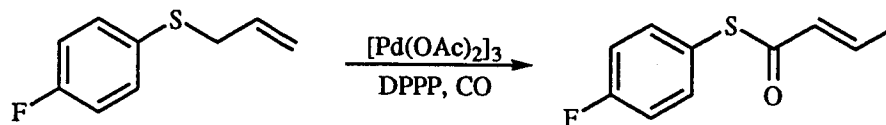
Palladium Catalyzed Carbonylation of Allyl 4-fluorophenyl Sulfide

(E)-2-Butenoic acid S-(4-fluorophenyl) ester (92). Following the general procedure, palladium acetate (22 mg, 0.098 mmol, 10%) and 1, 3-bis (diphenylphosphino) propane (41 mg, 0.098 mmol, 10%) were placed in a dry autoclave liner followed by allyl 4-fluorophenyl sulfide (165 mg, 0.98 mmol) and 4 mL of dry distilled toluene. After assembly of the autoclave and pressurizing to 1000 psi of CO, the reaction was allowed to proceed at 140°C for 45h. The ¹H NMR yield was determined to be 39% with 74% conversion. Purification by chromatography on silica gel with 5% ethyl acetate in hexanes as eluant yielded the pure product. (Table 18, entry 8)

¹H NMR (200 MHz, CDCl₃) δ 7.34–7.27 (m, 2H, Ar-H), 7.05–6.81 (m, 3H, Ar-H, =CH-CH₃), 6.10 (dq, *J* = 15.4, 1.7 Hz, 1H, CO-CH=), 1.83 (dd, *J* = 6.9, 1.7 Hz, 3H, CH₃) ppm.; ¹³C NMR (75 MHz, CDCl₃) δ 187.9, 163.5 (d, *J*_{C-F} = 250.0 Hz), 142.4, 136.7 (d *J*_{C-F} = 8.9 Hz), 129.2, 122.9, 116.4 (d *J*_{C-F} = 21.9 Hz), 18.1 ppm.; IR neat, ν_{max} 1681, 1637, 1591, 1491, 1441, 1287, 1229, 1155, 1040, 960, 816 cm⁻¹; MS (*m/z*) 196 (M⁺, 100), 143, 127, 100, 84; HRMS calcd for C₁₀H₉FOS, 196.0358, found 196.0353.

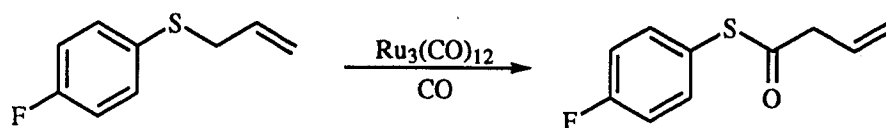
Ruthenium Catalyzed Carbonylation of Allyl 4-fluorophenyl Sulfide

3-Butenoic acid *S*-(4-fluorophenyl) ester (93). Following the general procedure, ruthenium carbonyl (59 mg, 0.09 mmol, 10%) and allyl 4-fluorophenyl sulfide (154 mg, 0.92 mmol) were placed in a dry autoclave liner followed by 4 mL of dry distilled toluene. After assembly of the autoclave and pressurizing to 1000 psi of CO, the reaction was allowed to proceed at 140°C for 87 h. ¹H NMR yield based on added internal standard was determined to be 35% with 60% conversion. Purification by silica gel chromatography yielded 58 mg (0.29 mmol, 32%) of the pure product. (Table 18, entry 9)

¹H NMR (200 MHz, CDCl₃) δ 7.31–7.23 (m, 2H, Ar-*H*), 7.06–6.94 (m, 2H, Ar-*H*), 5.97–5.76 (m, 1H, CH₂CH=), 5.23–5.12 (m, 2H, =CH₂), 3.30 (dt, *J* = 7.0, 1.3, 2H, CH₂CH=) ppm.; ¹³C NMR (75 MHz, CDCl₃) δ 195.2, 163.5 d *J*_{C-F} = 250.1 Hz, 136.6 d *J*_{C-F} = 8.0 Hz, 130.0, 129.4, 120.3, 116.5 d *J*_{C-F} = 22.2 Hz, 48.0 ppm.; IR neat, ν_{max} 1704, 1639, 1591, 1490, 1399, 1228, 1158, 1118, 1092, 1003, 829, 778, 704 cm⁻¹; MS (*m/z*) 196 (M⁺), 169, 128 (100), 119, 83; HRMS calcd for C₁₁H₁₂FOS, 196.0358, found 196.0351.

Palladium Catalyzed Carbonylation of Allyl Benzyl Sulfide

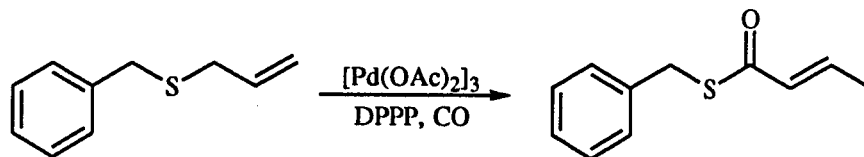

(*E*)-2-Butenoic acid *S*-benzyl ester (100). Following the general procedure, palladium acetate (21 mg, 0.094 mmol, 10%) and 1, 3-bis (diphenyl-phosphino) propane (39 mg, 0.094 mmol, 10%) were placed in a dry autoclave liner followed by allyl benzyl sulfide

(155 mg, 0.94 mmol) and 4 mL of dry distilled toluene. After assembly of the autoclave and pressurizing to 1000 psi of CO, the reaction was allowed to proceed at 140°C for 45h. The ^1H NMR yield based on added internal standard was determined to be 43% with 59% conversion. Purification by flash chromatography on silica gel with 5% ethyl acetate in hexanes as eluant yielded the pure product. (Table 19, entry 9)

^1H NMR (200 MHz, CDCl_3) δ 7.33–7.22 (m, 5H, Ar-H), 6.93 (dq, $J = 15.4, 6.9$, Hz, 1H, =CHCH₃), 6.14 (dq, $J = 15.4, 1.7$ Hz, 1H, COCH=), 4.18 (s, 2H, SCH₂), 1.87 (dd, $J = 6.9, 1.7$ Hz, 3H, CH₃) ppm.; ^{13}C NMR (75 MHz, CDCl_3) δ 189.1, 141.2, 137.7, 129.7, 128.8, 128.6, 127.2, 32.8, 17.9 ppm.; IR neat, ν_{max} 1686, 1638, 1495, 1553, 1415, 1294, 1242, 1119, 1071, 1007, 921, 702 cm^{-1} ; MS (m/z) 192 (M^+), 131, 119 (100), 100, 91; HRMS calcd for $\text{C}_{11}\text{H}_{12}\text{OS}$ 192.0609, found 192.0605.

Ruthenium Catalyzed Carbonylation of Allyl Benzyl Sulfide

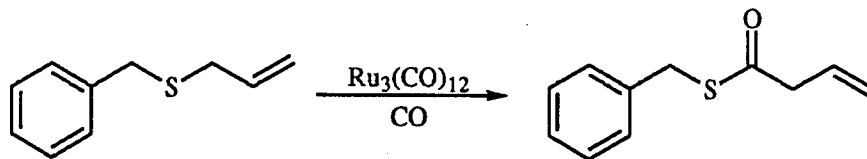

3-Butenoic acid *S*-benzyl ester (107). Following the general procedure, ruthenium carbonyl (74 mg, 0.116 mmol, 10%) and allyl benzyl sulfide (190 mg, 1.16 mmol) were placed in a dry autoclave liner followed by 4 mL of dry distilled toluene. After assembly of the autoclave and pressurizing to 1000 psi of CO, the reaction was allowed to proceed at 140°C for 72 h. ^1H NMR yield based on added internal standard was determined to be 50% with 72% conversion. Purification by gel permeation chromatography on a

polystyrene packed HPLC column yielded 88 mg (0.46 mmol, 40%) of the pure product. (Table 19, entry 10)

^1H NMR (200 MHz, CDCl_3) δ 7.30–7.21 (m, 5H, Ar-H), 6.03–5.82 (m, 1H, $\text{CH}_2\text{CH=}$), 5.26–5.16 (m, 2H, $=\text{CH}_2$), 4.12, (s, 2H, SCH_2), 3.21 (dt, $J = 7.0, 1.3$ Hz, 2H, $\text{CH}_2\text{CH=}$) ppm.; ^{13}C NMR (75 MHz, CDCl_3) δ 196.6, 137.4, 129.7, 128.8, 128.6, 127.3, 119.9, 48.2, 33.2 ppm.; IR neat, ν_{max} 1674, 1637, 1495, 1446, 1285, 1161, 1046, 961, 913, 811, 701 cm^{-1} ; MS (m/z) 192, 91, 69 (100), 41; HRMS calcd for $\text{C}_{11}\text{H}_{12}\text{OS}$, 192.0609, found 192.0596. Anal. calcd for $\text{C}_{11}\text{H}_{12}\text{OS}$: C, 68.71; H, 6.29. Found: C, 68.66; H, 6.56.

Palladium Catalyzed Carbonylation of Benzyl (2-methyl-2-propenyl) Sulfide

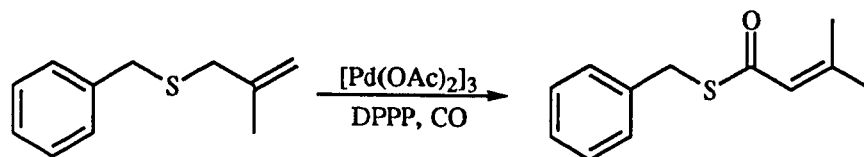

3-Methyl-2-butenoic acid S-benzyl ester (103). Following the general procedure, palladium acetate (44 mg, 0.199 mmol, 10%) and 1, 3-bis (diphenylphosphino) propane (82 mg, 0.199 mmol, 10%) were placed in a dry autoclave liner followed by benzyl (2-methyl-2-propenyl) sulfide (352 mg, 1.98 mmol) and 8 mL of dry distilled toluene. After assembly of the autoclave and pressurizing to 1000 psi of CO, the reaction was allowed to proceed at 140°C for 44h. ^1H NMR yield based on added internal standard was determined to be 22% with 30% conversion. Purification by recycling HPLC yielded the pure product.

^1H NMR (200 MHz, CDCl_3) δ 7.23–7.15 (m, 5H, Ar-H), 5.89 (apparent quintet, $J = 1.3$ Hz, 1H, =CH), 4.05 (s, 2H, SCH₂), 2.09 (d, $J = 1.3$ Hz, 3H, CH₃), 1.78 (d, $J = 1.3$ Hz, 3H, CH₃) ppm.; ^{13}C NMR (75 MHz, CDCl_3) δ 188.3, 154.2, 138.1, 128.8, 128.5, 127.0, 122.8, 32.9, 27.2, 21.2 ppm.; IR neat, ν_{max} 1674, 1629, 1444, 1379, 1204, 1092, 1012, 841, 798, 704 cm^{-1} ; MS (m/z) 206 (M^+), 91, 83 (100); HRMS calcd for $\text{C}_{12}\text{H}_{14}\text{OS}$, 206.0765, found 206.0775; Anal. calcd for $\text{C}_{12}\text{H}_{14}\text{OS}$: C, 69.86; H, 6.84. Found: C, 70.04; H, 6.76.

Ruthenium Catalyzed Carbonylation of Benzyl (2-methyl-2-propenyl) Sulfide

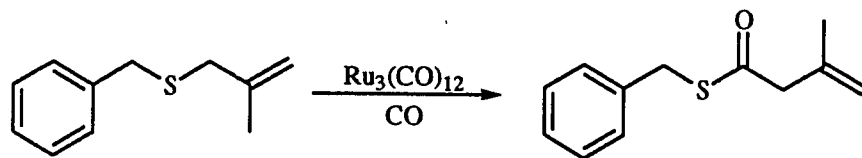

3-Methyl-3-butenyl S-benzyl ester (104). Following the general procedure, ruthenium carbonyl (115 mg, 0.18 mmol, 10%) and benzyl (2-methyl-2-propenyl) sulfide (322 mg, 1.8 mmol) were placed in a dry autoclave liner followed by 4 mL of dry distilled toluene. After assembly of the autoclave and pressurizing to 1000 psi of CO, the reaction was allowed to proceed at 140°C for 72 h. ^1H NMR yield based on added internal standard was determined to be 27% with 53% conversion. Purification by recycling HPLC chromatography yielded the pure product (88 mg, 24% yield).

^1H NMR (200 MHz, CDCl_3) δ 7.21–7.16 (m, 5H, Ar-H), 4.87–4.80 (m, 2H, =CH₂), 4.03 (s, 2H, SCH₂), 3.17 (s, 2H, COCH₂), 1.71 (s, 3H, CH₃) ppm.; ^{13}C NMR (75 MHz, CDCl_3) δ 196.3, 138.3, 137.4, 128.7, 128.5, 127.2, 115.9, 52.4, 33.3, 22.3 ppm.; IR neat, ν_{max} 1688, 1648, 1496, 1453, 1377, 1186, 1059, 1004, 900, 701 cm^{-1} ; MS (m/z) 206

(M⁺), 178, 122, 91 (100), 83; HRMS calcd for C₁₂H₁₄OS, 206.0765, found 206.0785.

Anal. calcd for C₁₂H₁₄OS: C, 69.86; H, 6.84. Found: C, 69.98 H, 7.06

Palladium Catalyzed Carbonylation of Allyl Hexyl Sulfide

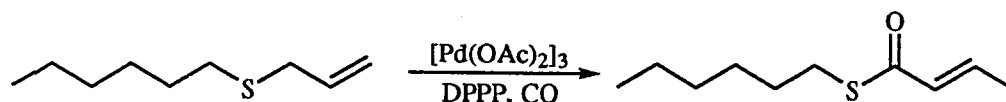

(E)-2-Butenoic acid S-hexyl ester (94). Following the general procedure, palladium acetate (24 mg, 0.11 mmol, 10%) and 1, 3-bis (diphenylphosphino) propane (44 mg, 0.11 mmol, 10%) were placed in a dry autoclave liner followed by allyl hexyl sulfide (169 mg, 1.06 mmol) and 4 mL of dry distilled toluene. After assembly of the autoclave and pressurizing to 1000 psi of CO, the reaction was allowed to proceed at 140°C for 48h. The ¹H NMR yield based on added internal standard was determined to be 88% with 100% conversion. Purification by column chromatography on silica gel eluting with hexanes yielded 146 mg (0.78 mmol, 74%) of the pure product—(Table 19, entry 1). An experiment run for 24 hours using 192.7 mg (1.2 mmol) substrate, 27 mg Pd(OAc)₂ (0.12 mmol) and 50 mg DPPP (0.12 mmol) in 4 mL toluene gave 46% isolated yield (104 mg). (Table 19, entry 2)

¹H NMR (200 MHz, CDCl₃) δ 6.79 (dq, *J* = 15.4, 6.9 Hz, 1H, =CHCH₃), 6.02 (dq, *J* = 15.4, 1.7 Hz, 1H, COCH=), 2.82 (t, *J* = 7.1 Hz, 2H, SCH₂), 1.77 (dd, *J* = 6.9, 1.7 Hz, 3H, =CHCH₃) 1.51–1.11 (m, 8H, H₃C–(CH₂)₄–CH₂S), 0.78 (t, *J* = 6.6 Hz, 3H, CH₂CH₃) ppm.; ¹³C NMR (75 MHz, CDCl₃) δ 190.0, 140.3, 130.2, 31.3, 29.5, 28.55, 28.48, 22.5, 17.8, 13.9 ppm.; IR neat, ν_{max} 2933, 2858, 1673, 1638, 1448, 1284, 1162, 1046, 961,

911, 813 cm^{-1} ; MS (m/z) 188 (M^+), 69 (100), 41, 39; HRMS calcd for $\text{C}_{10}\text{H}_{18}\text{OS}$, 186.1078, found 186.1068.

Ruthenium Catalyzed Carbonylation of Allyl Hexyl Sulfide

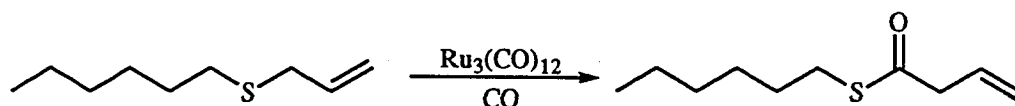

3-Butenoic acid *S*-hexyl ester (95). Following the general procedure, ruthenium carbonyl (81 mg, 0.13 mmol, 10%) and allyl hexyl sulfide (199 mg, 1.25 mmol) were placed in a dry autoclave liner followed by 5 mL of dry distilled toluene. After assembly of the autoclave and pressurizing to 1000 psi of CO , the reaction was allowed to proceed at 130°C for 72 h. The ^1H NMR yield based on added internal standard was determined to be 24% with 58% conversion. Purification by recycling HPLC chromatography yielded the pure product. (Table 19, entry 3)

^1H NMR (200 MHz, CDCl_3) δ 6.00–5.83 (m, 1H, $\text{CH}_2\text{CH}=\text{}$), 5.25–5.16 (m 2H, $=\text{CH}_2$), 3.30 (m, 2H, COCH_2), 2.87 (t, $J = 7.2$ Hz, 2H, SCH_2), 1.61–1.20 (m, 8H, $\text{H}_3\text{C}-(\text{CH}_2)_4-\text{CH}_2\text{S}$), 0.88 (t, $J = 6.7$ Hz, 3H, CH_2CH_3) ppm.; ^{13}C NMR (75 MHz, CDCl_3) δ 197.4, 130.1, 119.6, 48.6, 31.2, 29.4, 28.9, 22.5, 14.0 ppm.; IR neat, ν_{max} 2956, 2926, 2857, 1688, 1640, 1558, 1459, 1260, 1055, 701 cm^{-1} ; MS (m/z) 186 (M^+), 131, 1919 (100), 85; HRMS calcd for $\text{C}_{10}\text{H}_{18}\text{OS}$, 186.1078, found 186.1080.

*Palladium Catalyzed Carbonylation of Allyl *s*-Butyl Sulfide*

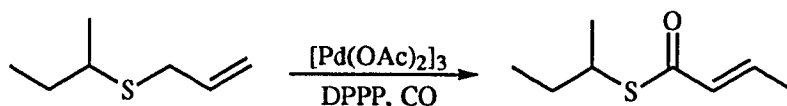

(E)-2-Butenoic acid *S*-(*s*-butyl) ester (96). Following the general procedure, palladium acetate (20 mg, 0.08 mmol, 10%) and 1, 3-bis (diphenylphosphino) propane (36 mg, 0.08 mmol, 10%) were placed in a dry autoclave liner followed by allyl *s*-butyl sulfide (114 mg, 0.88 mmol) and 3 mL of dry distilled toluene. After assembly of the autoclave and pressurizing to 1000 psi of CO, the reaction was allowed to proceed at 140°C for 45h. The ¹H NMR yield based on added internal standard was determined to be 86% with 100% conversion. Purification by column chromatography on silica gel eluting with hexanes yielded the pure product—(Table 19, entry 4). An experiment run for 24 hours using 268 mg (2.1 mmol) substrate, 46 mg Pd(OAc)₂ (0.2 mmol) and 85 mg DPPP (0.2 mmol) in 8 mL toluene gave 49% isolated yield (160 mg). (Table 19, entry 5)

¹H NMR (200 MHz, CDCl₃) δ 6.77 (dq, *J* = 15.4, 6.9 Hz, 1H, =CHCH₃), 6.00 (dq, *J* = 15.4, 1.7 Hz, 1H, COCH=), 3.47 (tq, app. sextet, *J* = 6.9, 6.9 Hz, 1H, SCH), 1.75 (dd, *J* = 6.9, 1.7 Hz, 3H, =CHCH₃) 1.58–1.44 (m, 2H, SCHCH₂), 1.20 (d, *J* = 6.9 Hz, 3H, SCHCH₃), 0.85 (t, *J* = 7.4 Hz, 3H, CH₂CH₃) ppm.; ¹³C NMR (75 MHz, CDCl₃) δ 189.9, 140.0, 130.4, 40.4, 29.5, 20.8, 17.7, 10.3 ppm.; IR neat, ν_{max} 2966, 2874, 1670, 1636, 1448, 1378, 1284, 1159, 1177, 1045, 961, 911, 812 cm⁻¹.

Ruthenium Catalyzed Carbonylation of Allyl s-Butyl Sulfide

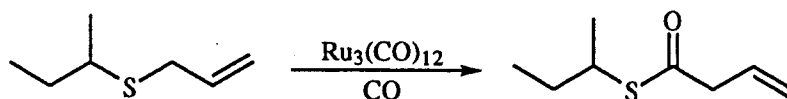

3-Butenoic acid *S*-(*s*-butyl) ester (97). Following the general procedure, ruthenium carbonyl (60 mg, 0.94 mmol, 10%) and allyl *s*-butyl sulfide (123 mg, 0.94 mmol) were placed in a dry autoclave liner followed by 4 mL of dry distilled toluene. After assembly

of the autoclave and pressurizing to 1000 psi of CO, the reaction was allowed to proceed at 130°C for 72 h. The ^1H NMR yield based on added internal standard was determined to be 14% with 65% conversion. Purification by recycling HPLC chromatography yielded the pure product. (Table 19, entry 6)

^1H NMR (200 MHz, CDCl_3) δ 5.78–5.60 (m, 1H, $\text{CH}_2\text{CH}=\text{}$), 5.13–4.95 (m 2H, $=\text{CH}_2$), 3.40 (tq, app. sextet, $J = 6.9, 6.9$ Hz, 1H, SCH), 3.16 (dt, $J = 7.1, 1.3$ Hz, 2H, COCH_2) 1.61–1.42 (m, 2H, SCH CH_2), 1.18 (d, $J = 6.9$ Hz, 3H, SCH CH_3), 0.81 (t, $J = 7.1$ Hz, 3H, CH_2CH_3) ppm.; ^{13}C NMR (75 MHz, CDCl_3) δ 197.3, 130.1, 119.4, 48.7, 40.9, 30.3, 20.7, 11.4; IR neat, ν_{max} 2968, 2926, 1678, 1637, 1457, 1379, 1224, 991 cm^{-1} ; MS (m/z) 158 (M^+), 130, 117, 101, 88, 69, 57 (100), 41, 39, 29.

Palladium Catalyzed Carbonylation of Allyl Dodecyl Sulfide

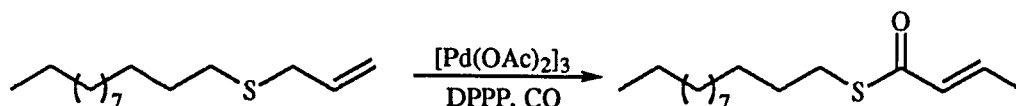

(*E*)-2-Butenoic acid *S*-dodecyl ester (**98**). Following the general procedure, palladium acetate (26 mg, 0.12 mmol, 10%) and 1,3-bis(diphenylphosphino)propane (48 mg, 0.12 mmol, 10%) were placed in a dry autoclave liner followed by allyl dodecyl sulfide (284 mg, 1.17 mmol) and 4 mL of dry distilled toluene. After assembly of the autoclave and pressurizing to 1000 psi of CO, the reaction was allowed to proceed at 140°C for 65h. The ^1H NMR yield based on added internal standard was determined to be 66% with 82% conversion. Purification by column chromatography on silica gel eluting with hexanes yielded 217 mg (0.69 mmol, 59%) of the pure product. (Table 19, entry 7)

^1H NMR (200 MHz, CDCl_3) δ 6.90 (dq, $J = 15.4, 6.9$ Hz, 1H, $=\text{CHCH}_3$), 6.13 (dq, $J = 15.4, 1.6$ Hz, 1H, $\text{COCH}=\text{}$), 2.92 (t, $J = 7.1$ Hz, 2H, SCH_2), 1.87 (dd, $J = 6.8, 1.6$ Hz, 3H, $=\text{CHCH}_3$) 1.70–1.20 (m, 20H, $\text{H}_3\text{C}-(\text{CH}_2)_{10}-\text{CH}_2\text{S}$), 0.88 (t, $J = 6.8$ Hz, 3H, CH_2CH_3) ppm.; ^{13}C NMR (75 MHz, CDCl_3) δ 190.1, 140.4, 130.3, 31.9, 29.61 (2), 29.59, 29.48, 29.3, 29.1, 28.9, 28.6, 22.7, 17.9, 14.1 ppm.; IR neat, ν_{max} 2906, 1678, 1639, 1451, 1376, 1282, 1162, 1116, 1046, 961, 912, 812, 702 cm^{-1} ; MS (m/z) 207 (M^+), 201 (100), 184, 168, 131, 119, 105, 87; HRMS calcd for $\text{C}_{16}\text{H}_{30}\text{OS}$, 270.2017, found 270.1994. Anal. Calcd for: C, 71.05; H, 11.18. Found: C, 70.76; H, 11.25.

Ruthenium Catalyzed Carbonylation of Allyl Dodecyl Sulfide

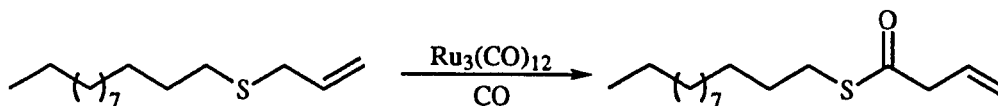

3-Butenoic acid *S*-dodecyl ester (99). Following the general procedure, ruthenium carbonyl (75 mg, 0.12 mmol, 10%) and allyl dodecyl sulfide (284 mg, 1.17 mmol) were placed in a dry autoclave liner followed by 5 mL of dry distilled toluene. After assembly of the autoclave and pressurizing to 1000 psi of CO, the reaction was allowed to proceed at 140°C for 72 h. The ^1H NMR yield based on added internal standard was determined to be 24% with 55% conversion. Purification by recycling HPLC chromatography yielded the pure product. (Table 19, entry 8)

^1H NMR (200 MHz, CDCl_3) δ 6.00–5.83 (m, 1H, $\text{CH}_2\text{CH}=\text{}$), 5.25–5.16 (m 2H, $=\text{CH}_2$), 3.30 (m, 2H, COCH_2), 2.87 (t, $J = 7.2$ Hz, 2H, SCH_2), 1.61–1.20 (m, 8H, $\text{H}_3\text{C}-(\text{CH}_2)_4-\text{CH}_2\text{S}$), 0.88 (t, $J = 6.7$ Hz, 3H, CH_2CH_3); ^{13}C NMR (75 MHz, CDCl_3) δ 197.4, 130.1,

119.6, 48.6, 31.2, 29.4, 28.9, 22.5, 14.0; IR neat, ν_{\max} 2941, 2854, 1689, 1639, 1459, 1292, 1120, 1006, 918, 729 cm^{-1} ; MS (m/z) 270 (M^+), 201, 168, 85, 69 (100), 57, 41; HRMS calcd for $\text{C}_{16}\text{H}_{30}\text{OS}$, 270.2017, found 270.1988.

Palladium Catalyzed Carbonylation of 2-Buten-1-yl Phenyl Sulfide

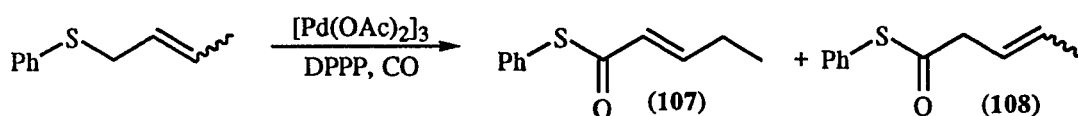

(E)-2-Pentenoic acid S-phenyl ester (107) and 3-pentenoic acid S-phenyl ester (108). Following the general procedure, palladium acetate (22 mg, 0.1 mmol, 10%) and 1, 3-bis (diphenylphosphino) propane (41 mg, 0.1 mmol, 10%) were placed in a dry autoclave liner followed by 1-(2-butenyl) phenyl sulfide (164 mg, 1.0 mmol) and 4 mL of dry distilled toluene. After assembly of the autoclave and pressurizing to 1000 psi of CO, the reaction was allowed to proceed at 140°C for 44h. The ^1H NMR yield based on added internal standard was determined to be 83% with 61% conversion. Purification by recycling HPLC on polystyrene yielded 100 mg (0.52 mmol, 52%) of the pure product as an inseparable mixture with compound 108.

^1H NMR (200 MHz, CDCl_3) δ 7.34–7.31 (m, 10H, Ar-H, 107 and 108), 6.96 (dt, $J = 15.5, 6.2$ Hz, 1H, =CHCH₂CH₃, 107), 6.09 (dt, $J = 15.5, 1.7$ Hz, 1H, COCH=, 107), 5.67–5.41 (m, 2H, CH₂CH=CHCH₃ E and Z, 108), 3.36–3.28 (m, 0.2 x 2H, COCH₂ Z, 108), 3.26–3.19 (m, 0.8 x 2H, COCH₂ E, 108), 2.26–2.10 (m, 2H, CH₂CH₃, 107), 1.68–1.59 (m, 3H, =CHCH₃, E and Z, 108), 1.01 (t, $J = 7.4$ Hz, 3H, CH₃, 107) ppm.; ^{13}C NMR (75 MHz, CDCl_3) δ 195.9 (CO, E 108), 195.6 (CO, Z, 108), 188.1 (CO, 107), 148.1, 134.6, 134.5, 131.4, 129.3, 129.1, 127.9, 127.7, 126.9, 122.0, 121.0, 47.2 (COCH₂C= E,

108), 41.8 (COCH₂C= Z, **108**), 25.3 (CH₂CH₃, **107**), 17.9 (=CHCH₃ E, **108**), 12.2 (=CHCH₃ Z, **108**), (CH₂CH₃, **107**) ppm.; IR neat, ν_{\max} 2969, 1683, 1632, 1477, 1440, 1276, 1152, 1054, 980, 790, 688 cm⁻¹; MS (m/z) 192 (M⁺), 109, 83 (100); HRMS calcd for C₁₁H₁₂OS, 192.0609, found 192.0614. Anal. calcd for C₁₁H₁₂OS: C, 68.71; H, 6.29. Found: C, 68.76; H, 6.38

Palladium Catalyzed Carbonylation of 3-(1-Butenyl) Phenyl Sulfide

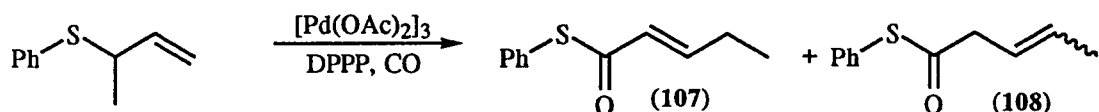

(E)-2-Pentenoic acid S-phenyl ester (107) and 3-pentenoic acid S-phenyl ester (108). Following the general procedure, palladium acetate (26 mg, 0.12 mmol, 10%) and 1, 3-bis (diphenylphosphino) propane (48 mg, 0.12 mmol, 10%) were placed in a dry autoclave liner followed by 3-(1-butenyl) phenyl sulfide (190 mg, 1.15 mmol) and 4 mL of dry distilled toluene. After assembly of the autoclave and pressurizing to 1000 psi of CO, the reaction was allowed to proceed at 140°C for 44h. The ¹H NMR yield based on added internal standard was determined to be 59% with 84% conversion. Purification by recycling HPLC on polystyrene yielded 107 mg (0.64 mmol, 56%) of the pure product as an inseparable mixture with compound **(108)**.

Spectral data are identical to those obtained in the previous reaction with 2-butenyl phenyl sulfide.

References

1. Colquhoun, H.M.; Thompson, D.J.; Twigg, M.V. *Carbonylation: Direct Synthesis of Carbonyl Compounds*, Plenum Press: New York (1991), (a) p. 3. (b) p. 61
2. Roelen, O. (to Ruhrchemie A.G.), German Patent No. 849, 548 (1938).
3. (a) O'Rourke, C.E.; Kavasmaneck, P.R.; Uhl, R.E. *ACS Symposium Series* **1981**, 159, 71. (b) Pruett, R.L. *J. Chem. Ed.* **1986**, 63, 196.
4. (a) Heck, R.F.; Breslow, D.S. *J. Am. Chem. Soc.* **1961**, 83, 4023. (b) Orchin, M. *Acc. Chem. Res.* **1981**, 2, 259.
5. Falbe, J.; Tumes, H.; Hahn, H.D. U. S. Patent 4, 039, 584 (1977), see also reference 3a.
6. Slauch, L.H.; Mullineaux, R.D. *J. Organomet. Chem.* **1968**, 13, 469.
7. (a) Piacenti, F.; Menchi, G.; Frediani, P.; Matteoli, U.; Botteghi, C. *Chem. Ind. (Milan)* **1978**, 60, 808. (b) For an excellent discussion of this system and the concepts of ligand promoted activity see: "Asymmetric Carbonylation", Consiglio, G. in *Catalytic Asymmetric Synthesis*, Ojima, I., Ed. VCH Publishers: New York (1993) pp. 273-302 and Woodard, S.S.; Finn, M.G.; Sharpless, K.B. *J. Am. Chem. Soc.* **1991**, 113, 106.
8. (a) Pruett, R.L. *Adv. Organomet. Chem.* **1979**, 17, 1 and references cited therein. (b) Marko, L. in *Aspects of Homogeneous Catalysis* Ugo, R., Ed. Vol II: Dordrecht and Boston (1973).
9. Yamaguchi, M. *Shokubai* **1969**, 11, 149; *C.A.* **1970**, 73, 13787.
10. Pino, P. *J. Organomet. Chem.* **1980**, 200, 223.
11. (a) Evans, D.; Osborn, J.A.; Wilkinson, G. *J. Chem. Soc. A* **1968**, 3133. (b) Brown, C.K.; Wilkinson, G. *J. Chem. Soc. A* **1970**, 2753. (c) Pruett, R.L. *Ann. N. Y. Acad. Sci.* **1977**, 295, 239.

12. (a) Kuntz, E.G. Fr. Patent 2, 550, 202 to Rhône-Poulenc Recherches. (b) Jenck, J. Fr. Patent 2, 478, 078 to Rhône-Poulenc Industries. (c) Kuntz, E.G. Fr. Patent 2, 349, 562 to Rhône-Poulenc Industries. (d) Kalck, P.; Monteil, F. *Adv. Organomet. Chem.* **1992**, 34, 219 and references cited therein. (e) Arhancet, J.P.; Davis, M.E.; Hanson, B.E. *J. Catal.* **1991**, 129, 94. (f) *Ibid.* **1991**, 129, 100. (g) Arhancet, J.P.; Davis, M.E.; Merola, J.S.; Hanson, B.E. *Nature*, **1989**, 339, 454.
13. (a) Whyman, R. *J. Organomet. Chem.* **1974**, 66, C23. (b) Csontos, G.; Heil, B.; Marko, L. *Ann. N. Y. Acad. Sci.* **1974**, 239, 47.
14. Collman, J.P.; Belmont, J.A.; Brauman, J.I. *J. Am. Chem. Soc.* **1983**, 105, 7288.
15. (a) Pruetz, R.L.; Smith, J.A. *J. Org. Chem.* **1969**, 34, 327. (b) Evans, D.; Yagupsky, G.; Wilkinson, G. *J. Chem. Soc. A* **1968**, 2260.
16. (a) Shen, T.Y. *Angew. Chem., Int. Ed. Engl.* **1972**, 11, 460. (b) Harrison, I.T.; Lewis, B.; Nelson, P.; Rooks, W.; Roszkowski, A.; Tomolonis, A.; Fired, J.H. *J. Med. Chem.* **1970**, 13, 203. (c) Riley, D.P.; Getman, D.P.; Beck, G.R.; Heintz, R.M. *J. Org. Chem.* **1987**, 52, 287.
17. Rieu, J. -P.; Boucherie, A.; Cousse, H.; Mouzin, G. *Tetrahedron* **1986**, 42, 4095.
18. (a) Amer, I.; Alper, H. *J. Am. Chem. Soc.* **1990**, 112, 3674. (b) Schrock, R.R.; Osborn, J.A. *Inorg. Chem.* **1970**, 9, 2339.
19. (a) Aresta, M.; Quaranta, E.; Albinati, A. *Organometallics* **1990**, 12, 2032, and references cited therein. (b) Horton, A.D.; Frijns, J.H.G. *Angew. Chem., Int. Ed. Engl.* **1991**, 30, 1152. (c) Dartinguenave, M.; Dartinguenave, I.; Beauchamp, A.L. *J. Am. Chem. Soc.* **1984**, 106, 6849.
20. Alper, H.; Zhou, J. -Q. *J. Org. Chem.* **1992**, 57, 3729 and references cited therein.
21. Keulemans, A.J.M.; Kwantes, A.; Van Bavel, T. *Rec. Trav. Chim. Pays-Bas* **1948**, 67, 298.
22. Bittler, K.; von Kutepow, N.; Neubauer, D.; Reis, H. *Angew. Chem., Int. Ed. Engl.* **1968**, 7, 329.

23. Knifton, J.F. *J. Org. Chem.* **1976**, 41, 2885.
24. Knifton, J.F. *J. Org. Chem.* **1976**, 41, 793.
25. It is believed that tin (II) chloride inserts into the Pt-Cl bond in a carbene-like fashion producing a $^{-}\text{SnCl}_3$ ligand which has a strong trans influence: (a) Kollar, L.; Kegl, T.; Bakos, J. *J. Organomet. Chem.* **1993**, 453, 155. (b) Pregosin, P.S.; Sze, S.N. *Helv. Chim. Acta* **1978**, 61, 1848. (c) Pino, P. *Ann. N. Y. Acad. Sci.* **1983**, 415, 111. (d) Holt, M.S.; Wilson, W.L.; Nelson, J.H. *Chem. Rev.* **1989**, 89, 11.
26. Fenton, D.M. *J. Org. Chem.* **1973**, 38, 3192.
27. (a) Sugi, Y.; Bando, K.; Shim, S. *Chem. Ind. (London)* **1975**, 2, 397. (b) Sugi, Y.; Bando, K. *Chem. Lett.* **1976**, 7, 727. (c) Consiglio, G.; Marchetti, M. *Chimia* **1976**, 30, 26. (d) Gladiali, S.; Faedda, G.; Marchetti, M.; Botteghi, C. *J. Organomet. Chem.* **1983**, 244, 289. (e) Consiglio, G.; Nefkens, S.C.A.; Pisano, C.; Wenzinger, F. *Helv. Chim. Acta* **1991**, 74, 323.
28. (a) Smidt, L.; Hafner, W.; Jira, R.; Seldmeier, J.; Sieber, R.; Ruttinger, R.; Kojer, H. *Angew. Chem.* **1959**, 71, 176. (b) Smidt, L.; Hafner, W.; Jira, R.; Sieber, R.; Seldmeier, J.; Sable, A. *Angew. Chem., Int. Ed. Eng.* **1962**, 1, 80. (c) Henry, P.M. *J. Am. Chem. Soc.* **1964**, 86, 3246. (d) Moiseev, I.I.; Levands, O.G.; Vargaftik, M.N. *J. Am. Chem. Soc.* **1974**, 96, 1003.
29. (a) Hosokawa, T.; Takano, M.; Murahashi, S.-I.; Ozaki, H.; Kitagawa, Y.; Sakaguchi, K. -I.; Katsube, Y. *J. Chem. Soc. Chem. Commun.* **1994**, 1433. (b) Hosokawa, T.; Murahashi, S.-I. *Acc. Chem. Res.* **1990**, 23, 49. (c) Zargarian, D.; Alper, H. *Organometallics* **1991**, 10, 2914.
30. (a) Alper, H.; Woell, J.B.; Despeyroux, B.; Smith, D.J.H. *J. Chem. Soc. Chem. Commun.* **1983**, 1270. (b) Alper, H.; Despeyroux, B.; Woell, J.B. *Tetrahedron Lett.* **1983**, 5691. (c) Despeyroux, B.; Alper, H. *Ann. N. Y. Acad. Sci.* **1983**, 415, 148.

31. Alper, H.; Hamel, N. *J. Am. Chem. Soc.* **1990**, 112, 2803.
32. Mlekuz, M.; Joo, F.; Alper, H. *Organometallics* **1987**, 6, 1591.
33. Laine, R.M.; Thomas, D.W.; Cary, L.W.; Buttrill, S.E. *J. Am. Chem. Soc.* **1978**, 100, 6527.
34. (a) Cavinato, G.; Toniolo, L. *J. Organomet. Chem.* **1990**, 398, 187. (b) Cavinato, G.; Toniolo, L.; Botteghi, C. *J. Mol. Catal.* **1985**, 32, 211. (c) Cavinato, G.; Toniolo, L.; Botteghi, C.; Gladiali, S. *J. Organomet. Chem.* **1982**, 229, 93. (d) Cavinato, G.; Toniolo, L. *J. Mol. Catal.* **1981**, 10, 161. (e) Cavinato, G.; Toniolo, L. *J. Mol. Catal.* **1979**, 6, 111.
35. (a) Milstein, D.; Huckaby, J.L. *J. Am. Chem. Soc.* **1982**, 104, 6150. (b) Milstein, D. *Acc. Chem. Res.* **1988**, 21, 428. (c) Murray, T.F.; Norton, J.F. *J. Am. Chem. Soc.* **1979**, 101, 4107. (d) Samsel, E.G.; Norton, J.F. *J. Am. Chem. Soc.* **1984**, 106, 5505.
36. Eisenberg, R.; Hendriksen, D.E. "The Binding and Activation of Carbon Monoxide, Carbon Dioxide and Nitric Oxide and Their Homogeneously Catalyzed Reactions." *Adv. Catal.* **1979**, 28, 79.
37. Stille, J.K. In *Comprehensive Organic Synthesis*, Ed. Trost, B. **1991**, Vol 4, p. 913.
38. (a) Paulik, F.E.; Roth, J.F. *J. Chem. Soc. Chem. Commun.* **1968**, 1578. (b) Roth, J.F.; Craddock, J.H.; Hershman, A.; Paulik, F.E. *Chem. Tech.* **1971**, 600.
39. Forster, D. *Adv. Organomet. Chem.* **1979**, 17, 255.
40. Forster, D. *J. Am. Chem. Soc.* **1976**, 98, 846.
41. (a) Adamson, G.W.; Daly, J.J.; Forster, D. *J. Organomet. Chem.* **1974**, 71, C17. (b) Forster, D.; Singleton, T.C. *J. Mol. Catal.* **1982**, 17, 299.
42. (a) Haynes, A.; Mann, B.E.; Morris, G.E.; Maitlis, P.M. *J. Am. Chem. Soc.* **1993**, 115, 4093. (b) Haynes, A.; Mann, B.E.; Gulliver, D.J.; Morris, G.E.; Maitlis,

- P.M. *J. Am. Chem. Soc.* **1991**, 113, 8567. (c) Hickey, C.; Maitlis, P. *J. Chem. Soc. Chem. Commun.* **1984**, 1609.
43. It is known that the alkyl to acyl migration is considerably (10^4 to 10^3 times) slower in non-polar solvents: (a) Mawby, R.; Basolo, F.; Pearson, R.G. *J. Am. Chem. Soc.* **1964**, 86, 3994. (b) Butler, I.S.; Basolo, F.; Pearson, R.G. *Inorg. Chem.* **1967**, 6, 2077.
44. (a) Yamamoto, A.; Ozawa, F.; Osakada, K.; Huang, L.; Son, T.-I.; Kawasaki, N.; Doh, M.-K. *Pure Appl. Chem.* **1991**, 63, 687. (b) It has been shown that this product forming step occurs by reductive elimination of RCOPd(OR')L_n rather than direct attack of the alcohol on the acyl ligand: Ozawa, F.; Kawasaki, N.; Okamoto, H.; Yamamoto, T.; Yamamoto, A. *Organometallics* **1987**, 6, 1640.
45. Grushin, V.V.; Alper, H. *Organometallics* **1993**, 12, 1890.
46. Heck, R.F. *Palladium Reagents in Organic Synthesis*; Academic Press: New York (1985).
47. Consiglio, G.; Waymouth, R.M. *Chem. Rev.* **1989**, 89, 257, and references cited therein.
48. Suzuki, A. *Pure Appl. Chem.* **1991**, 63, 419.
49. Grushin, V.V.; Alper, H. *J. Chem. Soc. Chem. Commun.* **1992**, 611 and references cited therein.
50. Alper, H.; Urso, F.; Smith, D.J.H. *J. Am. Chem. Soc.* **1983**, 105, 6737.
51. Calet, S.; Urso, F.; Alper, H. *J. Am. Chem. Soc.* **1989**, 111, 931.
52. (a) Alper, H.; Perera, C.P.; Ahmed, F.R. *J. Am. Chem. Soc.* **1981**, 103, 1289. (b) Alper, H.; Mahatantila, C.P. *Organometallics* **1982**, 1, 70. (c) Roberto, D.; Alper, H. *J. Am. Chem. Soc.* **1989**, 111, 7539.
53. (a) Alper, H.; Arzoumanian, H.; Pettrignani, J.-F. Saldana-Maldonado, M. *J. Chem. Soc. Chem. Commun.* **1985**, 340. (b) Wang, M.; Calet, S.; Alper, H. *J. Org. Chem.* **1989**, 54, 20.

54. Wang, M.; Alper, H. *J. Am. Chem. Soc.* **1992**, 114, 7018.
55. (a) Khumtaveeporn, K.; Alper, H. *J. Am. Chem. Soc.* **1994**, 116, 5662. (b) Khumtaveeporn, K.; Alper, H. *J. Org. Chem.* **1994**, 59, 1414.
56. (a) Tsuji, J.; Kiji, J.; Imamura, S.; Morikawa, M. *J. Am. Chem. Soc.* **1964**, 86, 4350. (b) Dent, W.T.; Long, R.; Whitfield, G.H. *J. Chem. Soc.* **1964**, 1588.
57. (a) Murahashi, S.-I.; Imada, Y.; Taniguchi, Y.; Higashiura, S. *J. Org. Chem.* **1993**, 58, 1538, and references cited therein. (b) Murahashi, S.-I.; Imada, Y.; Taniguchi, Y.; Higashiura *Tetrahedron Lett.* **1988**, 29, 4945.
58. Tsuji, J.; Sato, K.; Okumoto, H. *J. Org. Chem.* **1984**, 49, 1341.
59. Ozawa, F.; Son, T.; Osakada, K.; Yamamoto, A. *J. Chem. Soc. Chem. Commun.* **1989**, 1067.
60. Bertani, R.; Cavinat, G.; Facchin, G.; Toniolo, L.; Vavasori, A. *J. Organomet. Chem.* **1994**, 466, 273 and see reference 59 for evidence supporting the σ -allyl mechanism.
61. Siegel, H.; Himmele, W. *Angew. Chem., Int. Ed. Engl.* **1980**, 19, 178.
62. Pummer, H.; Neurrenbach, *Pure Appl. Chem.* **1975**, 43, 527.
63. Ojima, I. *Chem. Rev.* **1988**, 88, 1011.
64. Takeuchi, R.; Ishii, N.; Sugiura, M.; Sato, N. *J. Org. Chem.* **1992**, 57, 4189.
65. Takeuchi, R.; Ishii, N., Sato, N. *J. Chem. Soc. Chem. Commun.* **1991**, 1247.
66. Takeuchi, R.; Sato, N. *J. Organomet. Chem.* **1990**, 393, 1.
67. Hudrlik, P.F.; Hudrlik, A.M.; Misra, R.N.; Peterson, D.; Withers, G.P. Kulkarni, A.K. *J. Org. Chem.* **1980**, 45, 4444.
68. Sadykhazde, S.I.; Mardanov, M.A.; Sultanova, Z.B.; Sultanov, R.A. *Azerb. Khim. Zh.* **1966**, 6, 29 (*Chem. Abstr.* **1967**, 67, 64470u) (virtually the same system was reported in reference 69).
69. Birkofer, L.; Quittman, W. *Chem. Ber.* **1985**, 118, 2874.

70. (a) Muchowski, J.M.; Naef, R.; Maddox, M.L. *Tetrahedron Lett.* **1985**, 5375. (b) Eisch, J.J.; Trainor, J.T. *J. Org. Chem.* **1963**, 28, 2870.
71. (a) Hudrlik et al.: "attempts to prepare and isolate simple α -trimethylsilyl aldehydes have been unsuccessful, suggesting that these compounds are highly reactive, losing silicon with great facility or undergoing isomerizations to silyl enol ethers." (reference 67) (b) Wilt, J.W.; Kolewe, O.; Kraemer, J.F. *J. Am. Chem. Soc.* **1969**, 91, 2624.
72. Burkhard, C.A.; Hurd, D.T. *J. Org. Chem.* **1952**, 17, 1107.
73. Chukovskaya, E.T.; Freidlina, R.K. *Izv. Akad. Nauk SSSR, Otd. Khim. Nauk* **1963**, 761 (*Chem. Abstr.* **1963**, 59, 7551h).
74. (a) Enders, D.; Lohray, B.B. *Angew. Chem., Int. Ed. Engl.* **1987**, 26, 351. (b) Comins, D.; Meyers, A. *Synthesis* **1978**, 403.
75. Doyle, M.M.; Jackson, W.R.; Perlmutter, P. *Aust. J. Chem.* **1989**, 42, 1907.
76. Sato, T.; Abe, T.; Kuwajima, I. *Tetrahedron Lett.* **1978**, 259.
77. Duhamel, L.; Gralak, J.; Bouyanzer, A. *J. Chem. Soc. Chem. Commun.* **1993**, 1763.
78. Zhou, J.-Q.; Alper, H. *Organometallics* **1994**, 13, 1586.
79. Crudden, C.; Alper, H. *J. Org. Chem.* **1994**, 59, 3091.
80. For leading references see: (a) Brook, A.G. *Acc. Chem. Res.* **1974**, 7, 77. (b) *Pure Appl. Chem.* **1966**, 13, 215. (c) Brook, A.G.; Bassindale, A.R. "Molecular Rearrangements of Organosilicon Compounds." In *Rearrangements in Ground and Excited States*; De Mayo, P. Ed.; Academic Press, New York (1980); part 2, p. 149. For specifically 1, 3 rearrangements see: (d) Brook, A.G.; MacRae, D.M.; Limburg, W.W. *J. Am. Chem. Soc.* **1967**, 89, 5493.
81. Danishefsky, S.; Kitahara, T. *J. Am. Chem. Soc.* **1974**, 96, 7807.
82. Although arenes are generally considered to be poor ligands for transition metals, there are several examples of the ability of one of the phenyl rings of BPh_4^- to act

- as a ligand: (a) Kruger, G.J.; du Preez, A.L.; Haines, L.M. *J. Chem. Soc. Dalton Trans.* **1974**, 1302. (b) Albano, P.; Aresta, M.; Manassero, M. *Inorg. Chem.* **1980**, 19, 1191. (c) Fachinetti, G.; Funailoli, T.; Zanazzi, P.F. *J. Chem. Soc. Chem. Commun.* **1988**, 1100. (d) Bochmann, M.; Karger, G.; Jaggar, A.G. *J. Chem. Soc. Chem. Commun.* **1990**, 1038. See also references 18b and 19. (e) Halpern, J.; Riley, D.P.; Chan, A.C.S.; Pluth, J.J. *J. Am. Chem. Soc.* **1977**, 99, 8055. (f) Albano, P.; Aresta, M.; Manassero, M. *Inorg. Chem.* **1980**, 19, 1069.
83. *Principles and Applications of Organotransition Metal Chemistry*, Collman, J.P.; Hegedus, L.S.; Norton, J.R.; Finke, R.G. Eds.; University Science Books: California, 1987.
84. When $\text{IrX}_3 \cdot \text{H}_2\text{O}$ is heated at 150°C under carbon monoxide, the corresponding halocarbonyls, $\text{IrX}_2(\text{CO})_2$ and $\text{IrX}(\text{CO})_3$, are produced. Iridium carbonyl is a minor product of this reaction, and is produced as a mixture of $\text{Ir}_4(\text{CO})_{12}$ and $[\text{Ir}(\text{CO})_4]_n$ 'Organic Syntheses via Metal Carbonyls,' Vol. 1, Ed. Wender, I. and Pino, P. John Wiley and Sons, New York (1968), pp 17 and 227. The halo iridium (I) carbonyls are likely precursors of the corresponding hydrides (see reference 11 a). Krogmann, K.; Binder, W.; Hansen, H.D. *Angew. Chem., Int. Ed. Engl.* **1968**, 7, 812.
85. (a) Olson, W.L.; Dahl, L.F. *J. Am. Chem. Soc.* **1986**, 108, 7657. (b) Chini, P.; Ercoli, R. *Gazz. Chim. Ital.* **1958**, 88, 1170.
86. (a) Noyori, R. *Tetrahedron* **1994**, 50, 4259. (b) Noyori, R.; Takaya, H. *Acc. Chem. Res.* **1990**, 23, 345.
87. Hayashi, T. Uozumi, Y. *J. Am. Chem. Soc.* **1991**, 113, 9887.
88. (a) Tamao, K.; Kakui, T.; Kumada, M. *J. Am. Chem. Soc.* **1978**, 100, 2268. (b) Fleming, I.; Sanderson, P.E.J. *Tetrahedron Lett.* **1987**, 28, 4229.
89. Sharpless, K.B. *Tetrahedron* **1994**, 50, 4235.

90. (a) Zhang, W.; Loebach, J.L.; Wilson, S.R.; Jacobsen, E.N. *J. Am. Chem. Soc.* **1990**, 112, 2801. (b) Jacobsen, E.N.; Zhang, W.; Muci, A.R.; Ecker, J.R. *J. Am. Chem. Soc.* **1991**, 113, 7063.
91. (a) Hayashi, T.; Konishi, M.; Kobori, Y.; Kumada, M.; Higuchi, T.; Hirotsu, K. *J. Am. Chem. Soc.* **1984**, 106, 158. (b) Hayashi, T. in *Catalytic Asymmetric Synthesis*, Ojima, I. Ed. V.C.H. Publishers: New York (1993). (c) Hayashi, T.; Yamamoto, A.; Hagihara, T.; Ito, Y. *Tetrahedron Lett.* **1986**, 27, 191. (d) Hayashi, T. *Pure Appl. Chem.* **1988**, 60, 7. (e) Hayashi, T.; Yamamoto, A.; Ito, Y.; Nishioka, E.; Miura, H.; Yanagi, K. *J. Am. Chem. Soc.* **1989**, 111, 6301.
92. Arzoumanian, H.; Buono, G.; Choukrad, M.; Petrignani, J.-F. *Organometallics* **1988**, 7, 59.
93. Consiglio in *Catalytic Asymmetric Synthesis*, Ojima, I. Ed. V.C.H. Publishers: New York (1993); (a) page 295 (b) page 274.
94. (a) Consiglio, G.; Morandini, F.; Scalone, M.; Pino, P. *J. Organomet. Chem.* **1985**, 279, 193. (b) Consiglio, G.; Rama, F. *J. Mol. Catal.* **1991**, 66, 1. (c) Haelg, P.; Consiglio, G.; Pino, P. *J. Organomet. Chem.* **1985**, 296, 281. See also reference 97.
95. Parinello, G.; Stille, J.K. *J. Am. Chem. Soc.* **1987**, 109, 7122.
96. Consiglio, G.; Morandini, F.; Scalone, M.; Pino, P. *J. Organomet. Chem.* **1985**, 279, 193.
97. Consiglio, G.; Nefkens, S.C.A.; Borer, A. *Organometallics* **1991**, 10, 2046.
98. Sakai, N.; Nozaki, K.; Takaya, H. *J. Chem. Soc. Chem. Commun.* **1994**, 395.
99. 1-Butene was the only terminal olefin reported in this publication (reference 97).
100. Consiglio, G.; Botteghi, C.; Salomon, C.; Pino, P. *Angew. Chem.* **1973**, 85, 663.
101. Stille, J.K.; Su, H.; Brechot, P.; Parrinello, G.; Hegedus, L.S. *Organometallics* **1991**, 10, 1183.
102. Sakai, N.; Mano, S.; Nozaki, K.; Takaya, H. *J. Am. Chem. Soc.* **1993**, 115, 7033.

103. Recently a cationic arene-Ruthenium-binap complex has been prepared by Takaya et al. and used in the asymmetric hydrogenation of ketones, but in this case, the chirality of the system resides in the phosphines. However it is interesting to note that when the arene was *p*-cymene, it remained bound to the ruthenium even on heating to 60 °C for 1 hour: (a) Mashima, K.; Kusano, K.-H.; Sato, N.; Matsumura, Y.-I.; Nozaki, K.; Kumobayashi, H.; Sayo, N.; Hori, Y.; Ishizaki, T.; Akutagawa, S.; Takaya, H. *J. Org. Chem.* **1994**, 59, 3064. (b) Mashima, K.; Kusano, K.-H.; Ohta, T.; Noyori, R.; Takaya, H. *J. Chem. Soc. Chem. Commun.* **1989**, 1208. A series of rhodium-achiral arene complexes were prepared by Landis and Halpern, who showed that these compounds were efficient catalysts for the hydrogenation of arenes: (c) Landis, C.R.; Halpern, J. *Organometallics* **1983**, 2, 840.
104. Crabtree, R.H.; Mellea, M.F.; Mihelcic, J.M.; Quirk, J.M. *J. Am. Chem. Soc.* **1982**, 104, 107.
105. (a) Tang, S.C.; Paxson, T.E.; Kim, L. *J. Mol. Catal.* **1980**, 2, 313. (b) Spencer, A. *J. Organomet. Chem.* **1977**, 124, 85. (c) Salvadori, P.; Vitulli, G.; Raffaelli, A.; Lazzaroni, R. *J. Organomet. Chem.* **1983**, 258, 351. (d) See also reference 112.
106. Elsevier, C.J. *J. Mol. Catal.* **1994**, 92, 285.
107. The decomposition of phosphine ligands such as triphenylphosphine by oxidative addition is well documented: Kong, K.-C.; Cheng, C.H. *J. Am. Chem. Soc.* **1991**, 113, 6131. It is likely that a similar phenomenon is occurring in our system.
108. We also attempted unsuccessfully to follow the reaction by ¹¹B NMR, however, we experienced difficulty with extensive line broadening and the low solubility of the zwitterionic complex (6).
109. Consiglio has demonstrated by the hydroformylation of 1-butene and both isomers of 2-butene that alkene complexation is the enantiodifferentiating step in

this reaction. He further postulated that these results can be extrapolated to most alkenes except in very rare cases: see reference 97.

110. K. Totland, Ph. D. thesis, Univ. of Ottawa, 1993.
111. Green, M.; Kuc, T.A. *J. Chem. Soc. Dalton Trans.* **1972**, 832.
112. It was previously reported that $[\text{Rh}(\text{COD})_2]^+\text{BF}_4^-$ did not catalyze the hydroformylation of 1-hexene except after the addition of phosphines: Crabtree, R.H.; Felkin, H. *J. Mol. Catal.* **1979**, 52, 75.
113. For the use of Et_3OBF_4 in palladium systems see: Eaborn, C.; Farrell, N.; Pidcock, A. *J. Chem. Soc. Dalton Trans.* **1976**, 289.
114. Schrock, R.R.; Osborn, J.A. *J. Am. Chem. Soc.* **1971**, 93, 3089.
115. It was found that the exclusion of oxygen from the system was crucial. If oxygen was allowed into the reaction during the preparation of the arene complex, the solution turned black. Similarly, if the 1-decene was not freshly distilled or stored in a Schlenk flask after distillation and deoxygenation by freeze-pump-thaw, the reaction mixture became *immediately* black upon its addition. Despite this fact, once all of the components were mixed, the reaction solution could be exposed to oxygen for brief periods during transfer of the glass liner to the autoclave. Thus the deoxygenation of 1-decene appeared to be more important than deoxygenation of the other components. This system was capricious, however, because in some cases when oxygen was rigorously excluded and the reaction mixture was an orange/red colour, the hydroformylation did not work.
116. Piotti, M.; Alper, H. unpublished results.
117. (a) Chamchaang, W.; Pinhas, A.R. *J. Chem. Soc. Chem. Commun.* **1988**, 710.
(b) *Ibid*, *J. Org. Chem.* **1990**, 55, 2943.
118. (a) Alper, H.; Roberto, D. *Organometallics* **1984**, 3, 1767. (b) Alper, H.; Hamel, N. *Tetrahedron Lett.* **1987**, 28, 3237.
119. Leonard, N.J.; Morrow, D.F.; Rogers, M.T. *J. Am. Chem. Soc.* **1957**, 79, 5476.

120. Evans, D.; Lockhart, I.M. *J. Chem. Soc.* **1965**, 4806.
121. Challis, B.C.; Challis, J.A. In: *The Chemistry of Amides*, Zabicky, J. Ed.; John Wiley and Sons: Toronto, 1970, p. 731.
122. The preparation of a variety of *N*-alkylated (R = Bu, Me, Bn) benzazepinones was reported by the photorearrangement of spiro-oxaziridines: Johnson, G.P.; Marples, B.A. *J. Chem. Soc. Per. Trans. 1* **1988**, 3399. The analogs of compound **53** (1-alkyl-1, 3, 4, 5-tetrahydro-2H-1-benzazepin-2-ones) were prepared in low yields (10–30%) along with the other isomer, which is analogous to compound **54** (2-alkyl-2, 3, 4, 5-tetrahydro-1H-benzazepin-2-ones). In general, the *syn*-oxaziridine gave amides of type **54**, and the *anti*-oxaziridines gave type **53** amides, but again the yields were usually ca. 20%. Mori et al. prepared the *N*-benzyl derivative of *N*-ethyl lactam (**53**), by insertion of carbon monoxide into an ortho substituted aryl bromide/alkyl amine (prepared in 5 steps) which cyclized to yield the corresponding benzazepin-2-one: (b) Mori, M.; Chiba, K.; Ban, Y. *J. Org. Chem.* **1978**, 43, 1684.
123. Katritzky, A.R.; Fan, W.-Q.; Akutagawa, K. *Tetrahedron* **1986**, 42, 4027.
124. (a) Smith, P.A.S.; Sullivan, J.M. *J. Org. Chem.* **1961**, 26, 1132. (b) Pinkus, G. *Chem. Ber.* **1893**, 26, 1077.
125. Getson, J.C.; Greene, J.M.; Meyers, A.I. *J. Het. Chem.* **1964**, 1, 300.
126. We thank Kanjai Khumtaveeporn for providing us with a sample of compound **70**.
127. Spears, G.W.; Nakanishi, K.; Ohfuné, Y. *Synlett* **1991**, 91.
128. (a) Raucher, S.; Klein, P. *Tetrahedron Lett.* **1980**, 4061. (b) Scheibye, S.; Pederson, B.S.; Lawesson, S.O. *Bull. Soc. Chim. Belg.* **1978**, 87, 229.
129. Roze, J.-C.; Pradere, J.-P.; Duguay, G.; Guevel, A.; Quiniou, H.; Poignant, S. *Can. J. Chem.* **1983**, 61, 1169.
130. Pradere, J.-P.; Roze, J.C.; Duguay, G. *J. Chem. Res (S)*, **1982**, 72; (*M*), **1982**, 901.
131. Dailey, O.D. *J. Org. Chem.* **1987**, 52, 1984.

132. (a) For an excellent review see: Yamamoto, A. *Adv. Organomet. Chem.* **1992**, 34, 111. (b) Alper, H.; Joo, F. *Organometallics* **1985**, 4, 1775.
133. Yamamoto, T.; Akimoto, M.; Yamamoto, A. *Chem. Lett.* **1983**, 1725.
134. Miyazawa, M.; Wang, S.-Z.; Takeda, H.; Yamamoto, A. *Synlett* **1992**, 323.
135. (a) Murahashi, S.-I.; Yasushi, I.; Nishimura, K. *Tetrahedron* **1994**, 50, 453. (b) Murahashi, S.-I.; Imada, Y.; Nishimura, K. *J. Chem. Soc. Chem. Commun.* **1988**, 1578.
136. It has been popular mythology since the discovery of Raney nickel that sulfur is a poison for almost every transition metal. Although there are some reports of such poisoning, (see for example reference 137 and references cited therein), there are also many metal catalyzed processes that employ sulfur containing ligands or substrates. For a good example of the beneficial affect of sulfur, see reference 55.
137. Auburn, P.R.; Whelan, J.; Bosnich, B. *J. Chem. Soc. Chem. Commun.* **1986**, 146.
138. The base catalyzed isomerization of allyl aryl sulfides is known: Tarbell, D.S.; McCall, M.A. *J. Am. Chem. Soc.* **1952**, 74, 48.
139. Osakada, K.; Yamamoto, T.; Yamamoto, A. *Tetrahedron Lett.* **1987**, 50, 6321.
140. Milstein, D. *Organometallics* **1982**, 1, 888.
141. (a) Okamura, H.; Miura, M.; Takei, H. *Tetrahedron Lett.* **1979**, 43. (b) Okamura, H.; Takei, H. *Tetrahedron Lett.* **1979**, 3425.
142. Trost, B.M.; Lautens, M. *J. Am. Chem. Soc.* **1987**, 109, 1469.
143. Wang, Ming de, Ph.D. thesis, 1993, Univ. of Ottawa.
144. Cope, A.C.; Morrison, D.E.; Field, L. *J. Am. Chem. Soc.* **1950**, 72, 59.
145. Masamune, S.; Hayase, Y.; Schilling, W.; Chan, W.K.; Bates, G.S. *J. Am. Chem. Soc.* **1977**, 99, 6756.
146. Piccolo, O.; Azzena, U.; Melloui, G.; Delogu, G.; Valoti, E. *J. Org. Chem.* **1991**, 56, 183.

Claims to Original Research

We have shown that the branched-selective hydroformylation of vinyltrimethylsilane can be affected under appropriate conditions using the zwitterionic rhodium complex $[\text{Rh}(\text{COD})^+]\text{BPh}_4^-$.¹ Furthermore, the linear isomer can be obtained selectively in high yield by the addition of only 2 equivalents of triphenylphosphine. Neutral rhodium complexes previously reported for the hydroformylation of vinyltrialkylsilanes required the addition of large excesses of phosphines (50–100 equiv. per Rh) to obtain >90% selectivity for the linear isomer.

The linear isomer can also be obtained selectively by the use of related cationic and zwitterionic iridium complexes. A wide variety of commercially available neutral iridium complexes are also effective catalysts for the hydroformylation reaction, if the complex is preactivated at 160 °C under CO and H₂. With $[\text{Ir}(\text{COD})_2^+]\text{BF}_4^-$, 97–100% selectivity for the linear isomer is obtained and the aldehyde is isolated in 65% yield.

The carbonylation of 6-membered ring heterocycles has been affected in low yields. Despite these low yields and the severe conditions, this is the first report of a carbonylation of a six membered ring.

The first example of the insertion of carbon monoxide into allylic carbon-sulfur bonds is described.² A wide variety of allyl aryl and allyl alkyl sulfides can be carbonylated to the corresponding thioesters using $\text{Pd}(\text{OAc})_2$ and DPPP or $\text{Ru}_3(\text{CO})_{12}$. These systems are complementary with the α , β - isomer being obtained in the Pd system and the β , γ -isomer obtained in the Ru system. The π -allyl nature of the reaction intermediates was confirmed by the use of methallyl and crotyl phenyl sulfide.

1. Crudden, C.M.; Alper, H. *J. Org. Chem.* **1994**, *59*, 3904.
2. Alper, H.; Crudden, C.M. *Manuscript in Preparation*.

Appendix: Selected Spectra

7.117
 7.082
 7.047
 7.012
 6.977
 6.942
 6.907
 6.872
 6.837
 6.802
 6.767
 6.732
 6.697
 6.662
 6.627
 6.592
 6.557
 6.522
 6.487
 6.452
 6.417
 6.382
 6.347
 6.312
 6.277
 6.242
 6.207
 6.172
 6.137
 6.102
 6.067
 6.032
 6.000
 5.965
 5.930
 5.895
 5.860
 5.825
 5.790
 5.755
 5.720
 5.685
 5.650
 5.615
 5.580
 5.545
 5.510
 5.475
 5.440
 5.405
 5.370
 5.335
 5.300
 5.265
 5.230
 5.195
 5.160
 5.125
 5.090
 5.055
 5.020
 4.985
 4.950
 4.915
 4.880
 4.845
 4.810
 4.775
 4.740
 4.705
 4.670
 4.635
 4.600
 4.565
 4.530
 4.495
 4.460
 4.425
 4.390
 4.355
 4.320
 4.285
 4.250
 4.215
 4.180
 4.145
 4.110
 4.075
 4.040
 4.005
 3.970
 3.935
 3.900
 3.865
 3.830
 3.795
 3.760
 3.725
 3.690
 3.655
 3.620
 3.585
 3.550
 3.515
 3.480
 3.445
 3.410
 3.375
 3.340
 3.305
 3.270
 3.235
 3.200
 3.165
 3.130
 3.095
 3.060
 3.025
 2.990
 2.955
 2.920
 2.885
 2.850
 2.815
 2.780
 2.745
 2.710
 2.675
 2.640
 2.605
 2.570
 2.535
 2.500
 2.465
 2.430
 2.395
 2.360
 2.325
 2.290
 2.255
 2.220
 2.185
 2.150
 2.115
 2.080
 2.045
 2.010
 1.975
 1.940
 1.905
 1.870
 1.835
 1.800
 1.765
 1.730
 1.695
 1.660
 1.625
 1.590
 1.555
 1.520
 1.485
 1.450
 1.415
 1.380
 1.345
 1.310
 1.275
 1.240
 1.205
 1.170
 1.135
 1.100
 1.065
 1.030
 1.000
 0.965
 0.930
 0.895
 0.860
 0.825
 0.790
 0.755
 0.720
 0.685
 0.650
 0.615
 0.580
 0.545
 0.510
 0.475
 0.440
 0.405
 0.370
 0.335
 0.300
 0.265
 0.230
 0.195
 0.160
 0.125
 0.090
 0.055
 0.020
 0.000

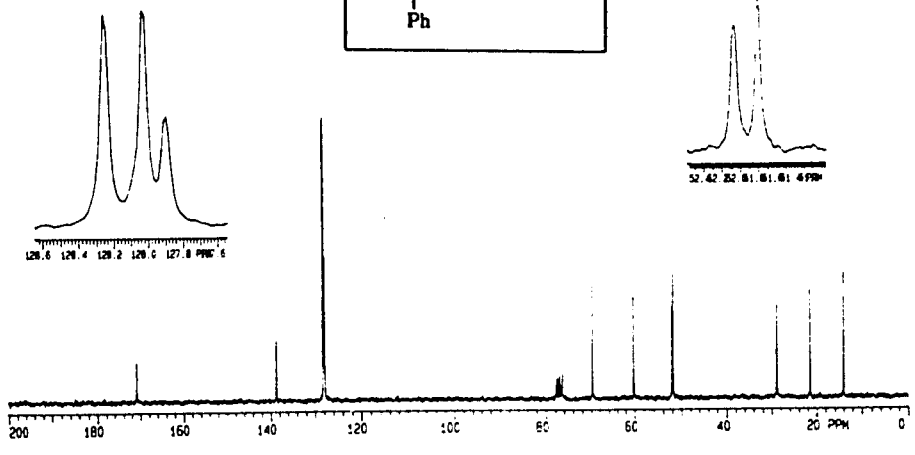
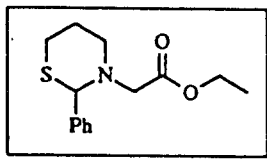
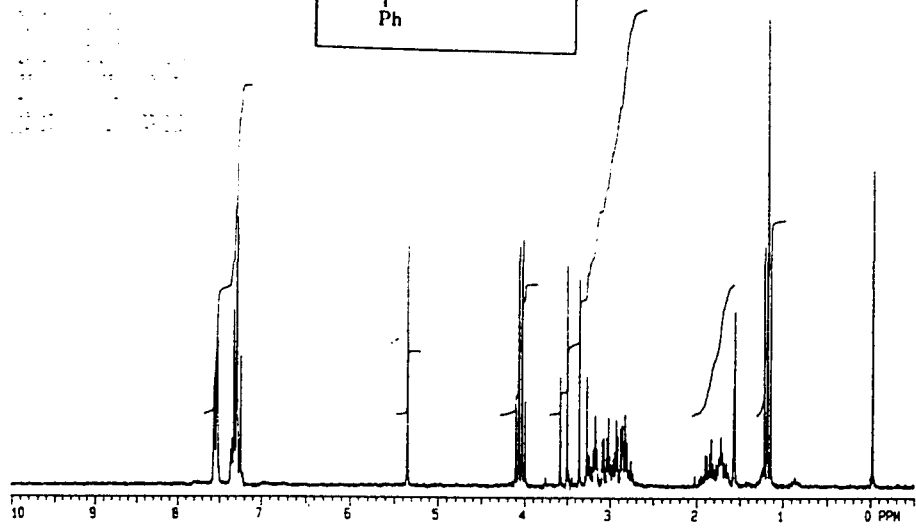
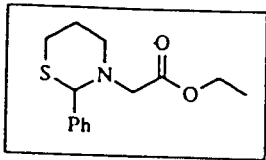

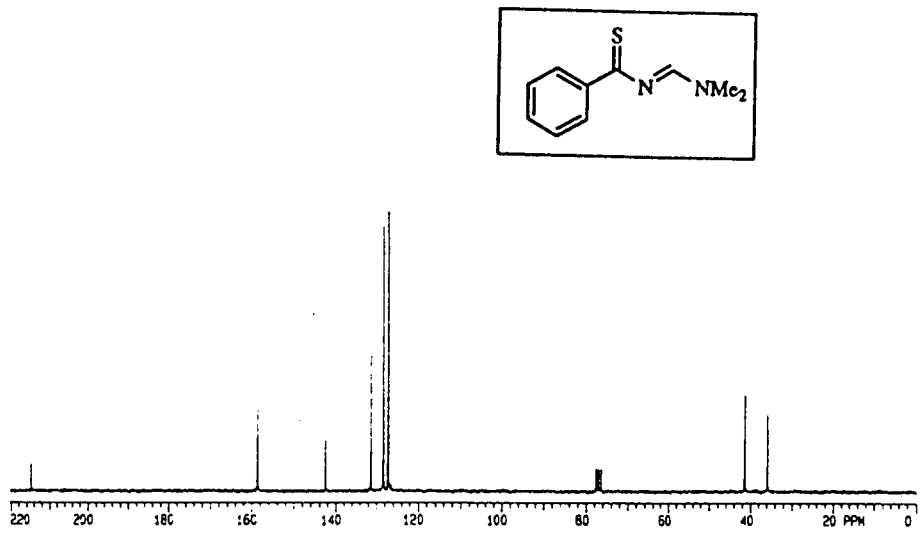
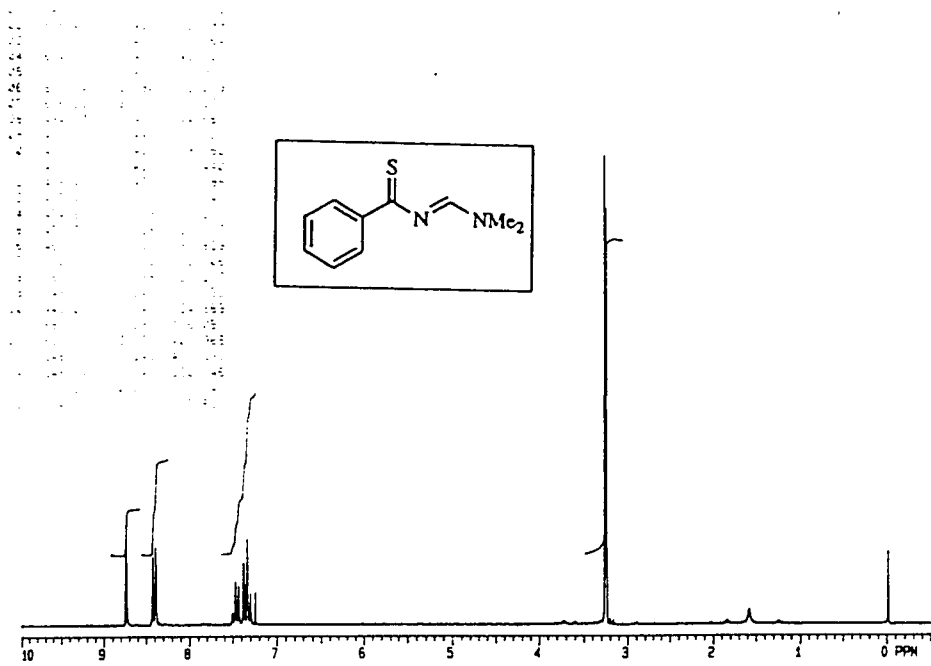

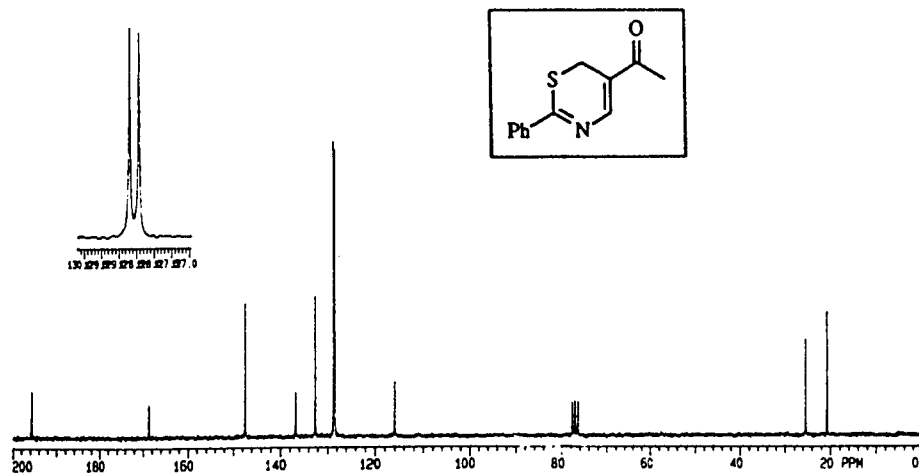
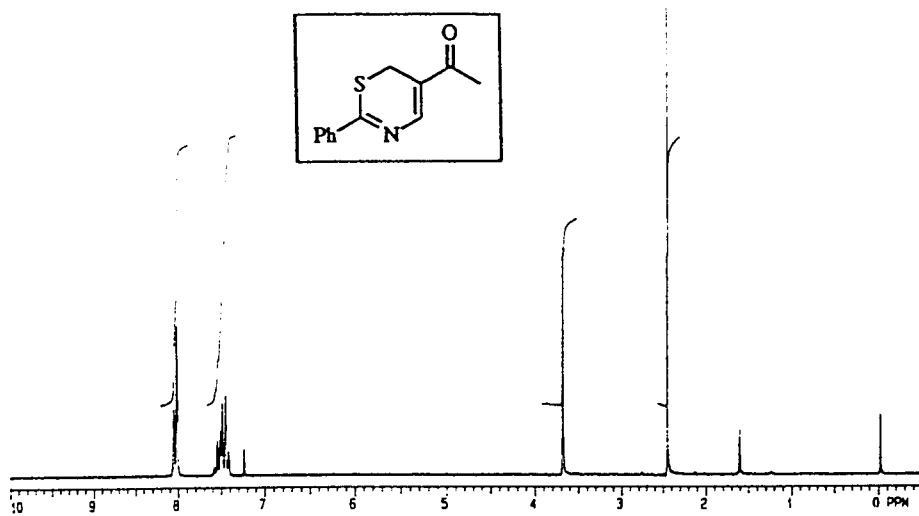

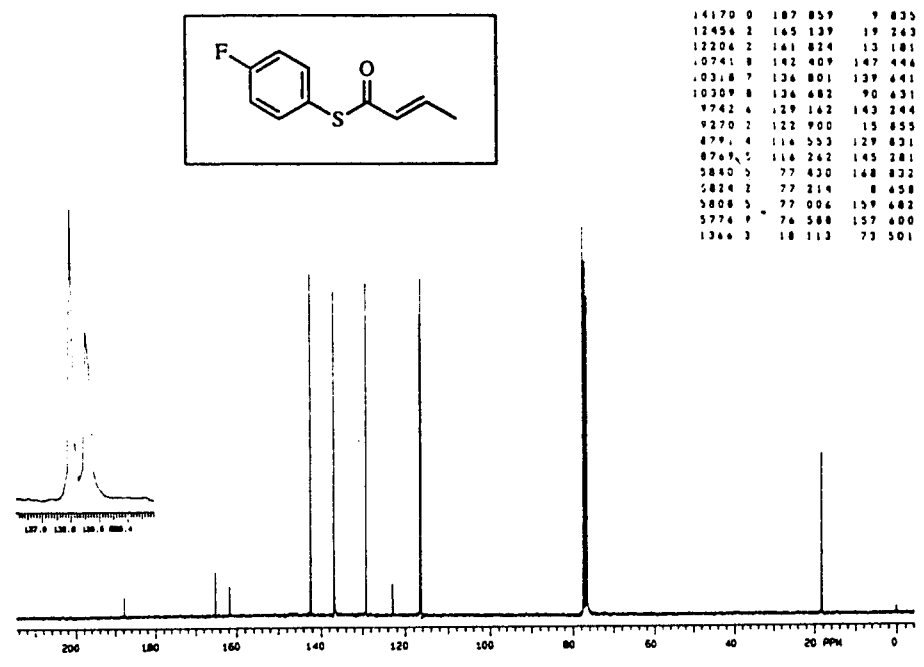
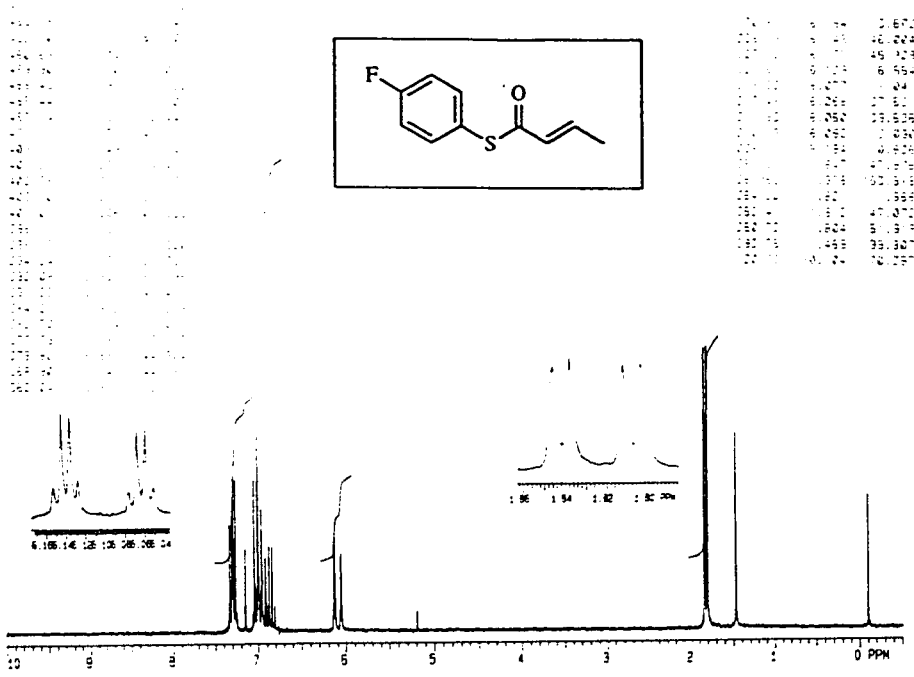

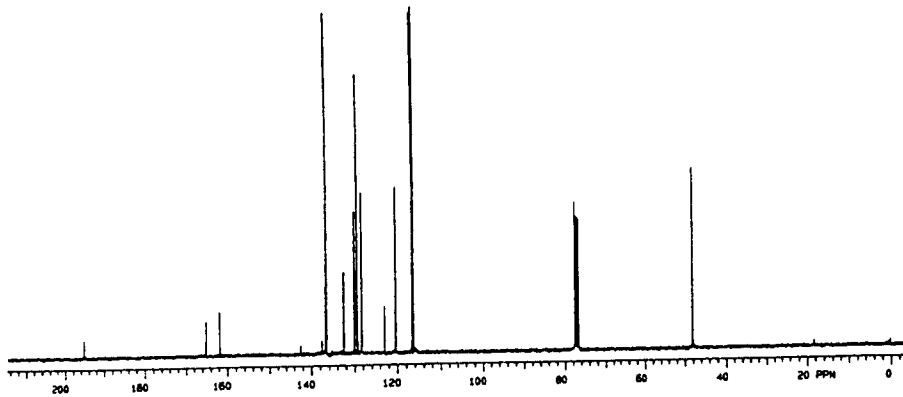
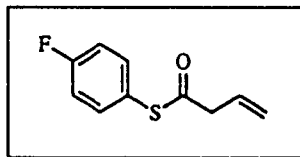
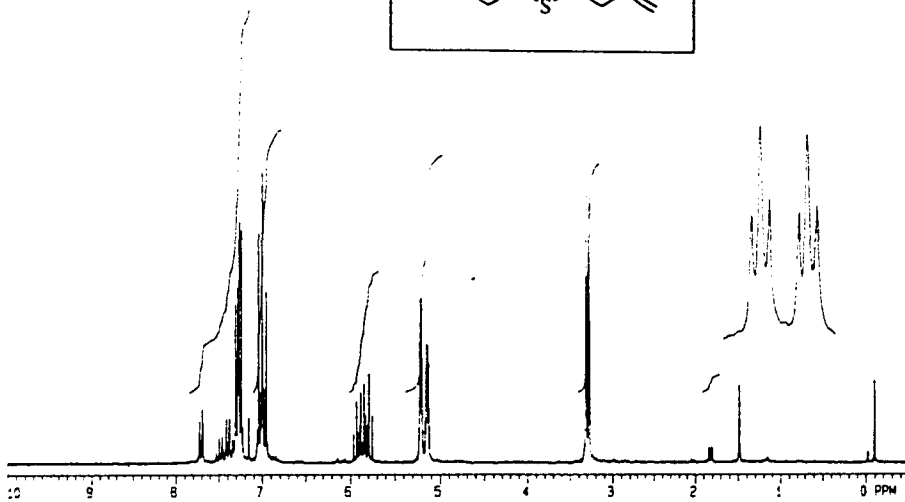
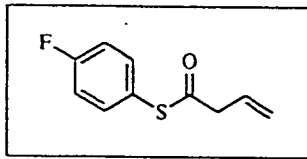

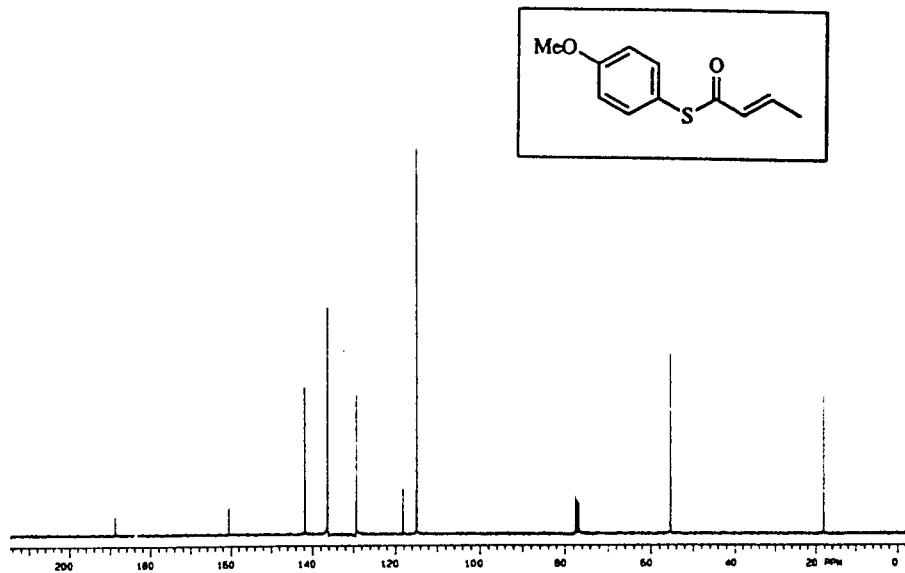
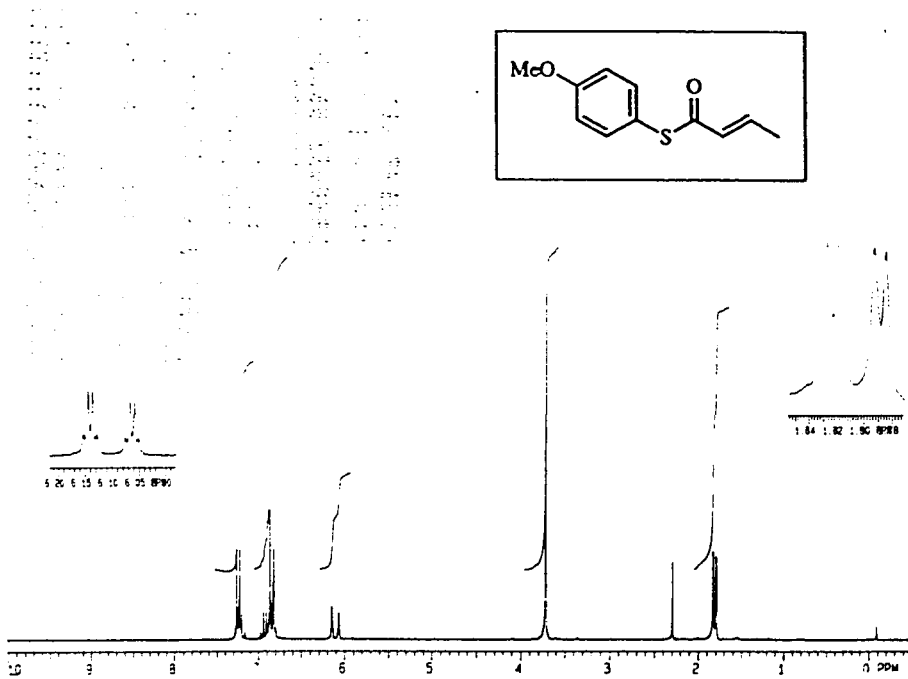

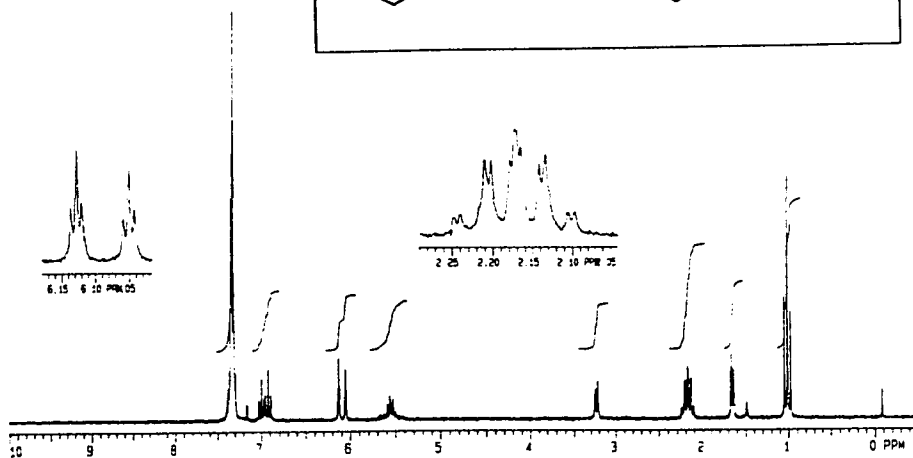
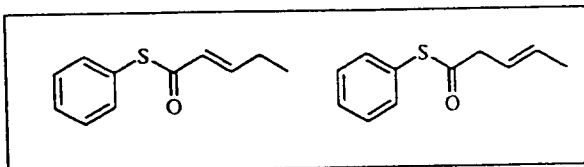

14184	8	188	281	12	538
11171	1	148	101	77	348
10155	4	134	437	24	137
10143	2	134	474	70	457
9909	8	131	379	32	715
9750	8	127	372	197	432
9737	4	129	694	204	715
9443	8	127	853	10	530
9429	7	127	644	28	407
9575	1	126	742	93	258
9204	7	121	531	39	412
8840	5	77	430	63	164
8808	5	77	504	77	489
8774	9	76	588	73	545
3559	7	47	193	58	615
1913	8	25	372	99	292
1356	0	18	204	20	639
985	4	12	004	64	804

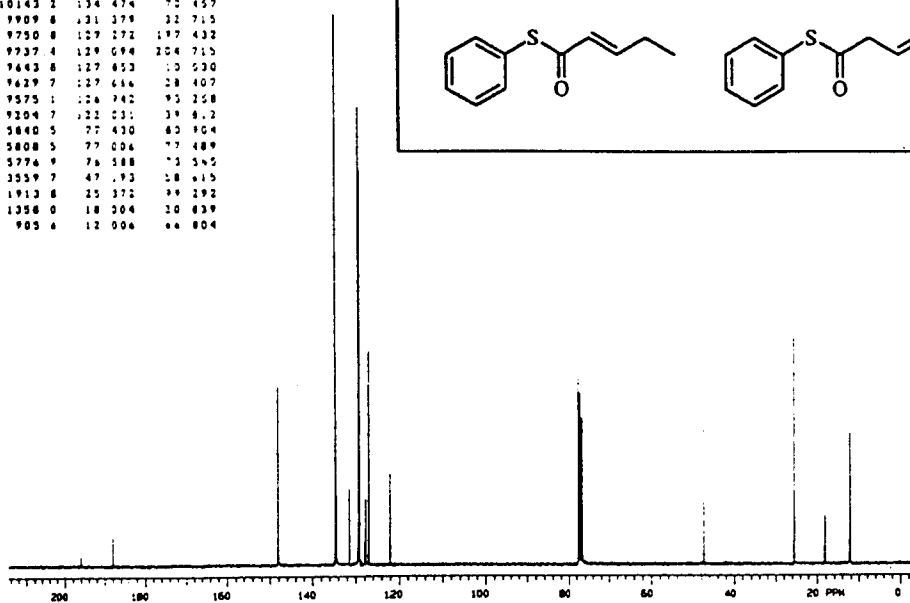
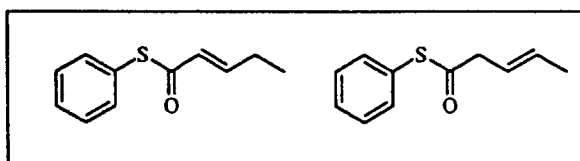

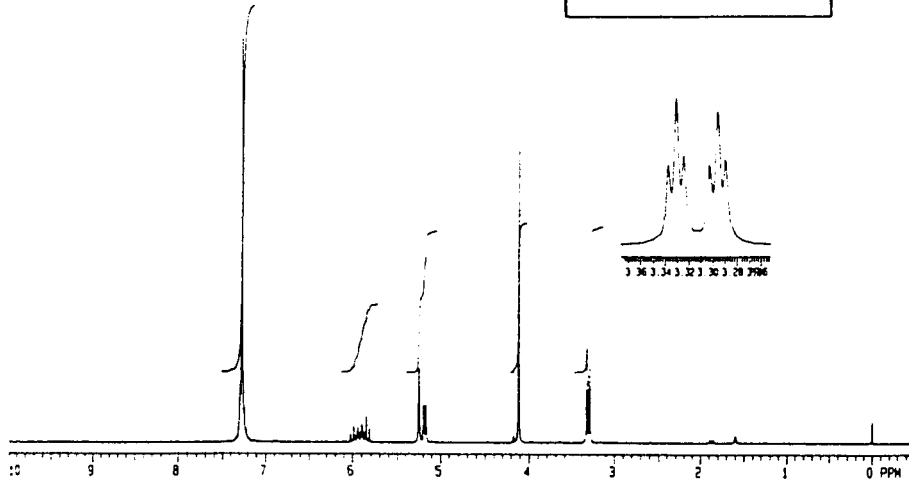
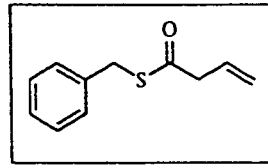

14263	3	189	094	9	851
10452	9	141	231	78	557
10384	8	137	703	16	473
9786	2	129	741	57	245
9716	6	128	818	114	282
9496	4	128	551	114	098
9591	9	127	145	46	454
5840	0	77	424	44	003
5808	0	77	000	44	224
5775	8	76	573	41	554
2474	8	32	809	65	877
1353	5	17	144	73	101

