



NOTICE

The quality of this microfiche is heavily dependent upon the quality of the original thesis submitted for microfilming. Every effort has been made to ensure the highest quality of reproduction possible.

If pages are missing, contact the university which granted the degree.

Some pages may have indistinct print especially if the original pages were typed with a poor typewriter ribbon or if the university sent us a poor photocopy.

Previously copyrighted materials (journal articles, published tests, etc.) are not filmed.

Reproduction in full or in part of this film is governed by the Canadian Copyright Act, R.S.C. 1970, c. C-30. Please read the authorization forms which accompany this thesis.

**THIS DISSERTATION
HAS BEEN MICROFILMED
EXACTLY AS RECEIVED**

AVIS

La qualité de cette microfiche dépend grandement de la qualité de la thèse soumise au microfilmage. Nous avons tout fait pour assurer une qualité supérieure de reproduction.

S'il manque des pages, veuillez communiquer avec l'université qui a conféré le grade.

La qualité d'impression de certaines pages peut laisser à désirer, surtout si les pages originales ont été dactylographiées à l'aide d'un ruban usé ou si l'université nous a fait parvenir une photocopie de mauvaise qualité.

Les documents qui font déjà l'objet d'un droit d'auteur (articles de revue, examens publiés, etc.) ne sont pas microfilmés.

La reproduction, même partielle, de ce microfilm est soumise à la Loi canadienne sur le droit d'auteur, SRC 1970, c. C-30. Veuillez prendre connaissance des formules d'autorisation qui accompagnent cette thèse.

**LA THÈSE A ÉTÉ
MICROFILMÉE TELLE QUE
NOUS L'AVONS REÇUE**

NON-LINEAR OPTIMAL FEEDBACK
REGULATOR

BY

TAYEL ESSAWY DABBOUS

A thesis submitted to the School of Graduate Studies,
University of Ottawa, in partial fulfilment
of the requirements for the degree of
Master of Applied Science

Department of Electrical Engineering
Faculty of Science and engineering
University of Ottawa
Ottawa, Canada
July, 1981

© Tayel Essawy Dabbous, Ottawa, Canada, 1981

I hereby declare that I am the sole author of this thesis.

I authorize University of Ottawa to lend this thesis to other institutions or individuals for the purpose of scholarly research.

T. E. DABBOUS

I further authorize University of Ottawa to reproduce this thesis by photocopying or by other means, in total or in part, at the request of other institutions or individuals for the purpose of scholarly research.

T. E. DABBOUS

University of Ottawa requires the signatures of all persons using or photocopying this thesis. Please sign below, and give address and date.

2

ABSTRACT

The theory of optimal feedback control which has been recently developed by Lukes and Willemstein [1,2], is presented. The proof of the existence of a unique optimal control, in the case of the free end problem, and the methods of calculating linear as well as non-linear feedback controls are given. The stability of an optimally regulated system, using Liapunov theory, is investigated.

The application of the optimal control theory [1,2] is considered for the analysis and design of an optimal satellite regulator. For this purpose, two problems are investigated.

In the first problem, the optimal regulation of satellite using a combination of reaction jets and flywheels, is considered. An algorithm for computing the feedback control is provided. A system control model, which minimizes the cost of fuel and energy, is developed. Using this model, the effectiveness of linear as well as non-linear feedback controls is justified. Further, the size of the domain over which reaction jets are shut off and the flywheels activated, is also indicated.

In the second problem, the optimal regulation of the satellite, using reaction jets with flywheels having fixed an-

gular velocities, is considered. The effect of linear, non-linear second order and third order feedback controls on system behaviour, is studied. The cost corresponding to each regulator, under different initial perturbations, is indicated. Further, the range in the state space E^n , over which these regulators are capable of regulating the system, is studied. The problem encountered in the application of the previous theory is also discussed in detail.

Finally, it is important to note that the theory of optimal feedback control presented here can only be applied when the state and control remain in the neighborhood of the origin in the state space E^n .

ACKNOWLEDGEMENTS

The author wishes to express his very deep gratitude to his advisor, professor N.U.AHMED, for his generous encouragement, understanding and guidance throughout this work, without which this thesis would not be possible.

Special thanks are also to professor K.F.SCHENK for his helpful suggestions, encouragement and discussions.

Special thanks to Mr. M.Mittal, Mr. S.Soy, Mr. S.Biswas and Mr. Y.Chen for long discussions and encouragement.

The author wishes also to express his appreciation to the faculty and staff of the Department of Electrical Engineering, University of Ottawa, for their kindness and moral support.

Thanks to the National Research Council and University of Ottawa for financial assistance during the period of this research.

CONTENTS

ABSTRACT	iv
ACKNOWLEDGEMENTS	vi
<u>Chapter</u>		<u>page</u>
I.	INTRODUCTION	1
II.	THEORETICAL BACKGROUND	4
	INTRODUCTION	4
	BASIC THEORY OF OPTIMAL FEEDBACK REGULATORS	6
	ASSUMPTIONS	6
	Class of admissible controls	7
	Definition of optimal feedback control	8
	Theory of optimal feedback regulators	8
	CONSTRUCTION OF THE OPTIMAL FEEDBACK CONTROL	10
	A METHOD FOR CALCULATING THE OPTIMAL CONTROL	32
	STABILITY OF OPTIMALLY REGULATED SYSTEM	35
	SUMMARY	38
III.	REGULATION OF SATELLITE ANGULAR MOMENTA USING JETS AND FLYWHEELS	39
	INTRODUCTION	39
	SYSTEM MODEL AND FORMULATION OF REGULATOR PROBLEM	40
	STRUCTURE OF OPTIMAL FEEDBACK REGULATOR	44
	SYSTEM CONTROL MODEL	46
	EFFECTIVENESS OF FEEDBACK REGULATORS	49
	SUMMARY	60
IV.	REGULATION OF SATELLITE ANGULAR MOMENTA USING FECTION JETS ONLY	61
	SYSTEM MODEL AND FORMULATION OF THE REGULATOR PROBLEM	62
	STRUCTURE OF OPTIMAL FEEDBACK REGULATOR	64
	EFFECTIVENESS OF FEEDBACK REGULATORS	65
	SUMMARY	90
V.	CONCLUSIONS	91

Appendix

Page

A. DERIVATION OF THE MATRIX RICCATI EQUATION 94

REFERENCES 97

5

3

LIST OF FIGURES

Figure		Page
2.1	Satellite Optimal Control System Model	51
2.2	Satellite Angular Momentum X - direction (with linear control)	52
2.3	Satellite Angular Momentum X - direction (with non-linear control)	54
2.4	Satellite Angular Momentum Y - direction (with linear control)	55
2.5	Satellite Angular Momentum Y - direction (with non-linear control)	55
2.6	Satellite Angular Momentum Z - direction (with linear control)	56
2.7	Satellite Angular Momentum Z - direction (with non-linear control)	56
2.8	Distance from the State to Origin (with linear control)	57
2.9	Distance from the State to Origin (with non-linear control)	57
2.10	Distance from Flywheel State to the Origin (with linear control)	58
2.11	Distance from Flywheel State to the Origin (with non-linear Control)	58
3.1	Satellite Angular Momentum X - direction (with Jet control), $d(0)=0.866$	67
3.2	Satellite Angular Momentum X - direction (with Jet control), $d(0)=1.368$	68
3.3	Satellite Angular Momentum X - direction (with Jet control), $d(0)=13.164$	69
3.4	Satellite Angular Momentum Y - direction (with Jet control), $d(0)=0.866$	70
3.5	Satellite Angular Momentum Y - direction (with Jet control), $d(0)=1.368$	71
3.6	Satellite Angular Momentum Y - direction (with Jet control), $d(0)=13.164$	72
3.7	Satellite Angular Momentum Z - direction (with Jet control), $d(0)=0.866$	73
3.8	Satellite Angular Momentum Z - direction (with Jet control), $d(0)=1.368$	74
3.9	Satellite Angular Momentum Z - direction (with Jet control), $d(0)=13.164$	75
3.10	Distance from the State to Origin (with Jet control), $d(0)=0.866$	76
3.11	Distance from the State to Origin (with Jet control), $d(0)=1.368$	77
3.12	Distance from the State to Origin (with Jet control), $d(0)=13.164$	78
3.13	Linear Feed-back Control, $d(0)=0.866$	79
3.14	Linear Feed-back Control, $d(0)=1.368$	80
3.15	Non-linear Second order Feed-back Control, $d(0)=0.866$	81
3.16	Non-linear Second order Feed-back Control, $d(0)=1.368$	82

Figure

Page

3.17 Non-linear Third order Feed-back Control, $d(0)=0.866$

83

3.18 Non-linear Third order Feed-back Control, $d(0)=1.368$

84

LIST OF TABLES

Table		Page
I	Size of Stability Domain	85
II	Cost Corresponding to Each Regulator	86
III	Number of Differential Equations required to generate the Control Sequence	89

Chapter I

INTRODUCTION

With present day technology, the physical processes which are, as a rule, controllable can be realized by various means depending on the system requirements. In this connection, there arises the question of finding an optimal control of the process. This control functions represent the feedback devices which operate upon the instantaneous state of the system to generate control signals. Then the control signals automatically return the system to a prescribed state of equilibrium whenever an impulsive disturbance occurs in the state. These regulator devices are widely used in aircraft flight controls and many other control systems.

In the early 60's, the problem of optimal feedback regulation for linear system was studied by Kalman and reexamined by Lukes and others. In [6] Lukes has found a proof of the fact that the stabilizability of the system is equivalent to the solvability of the Kalman-Riccati matrix equation.

The first attempt to treat the problem of feedback regulation for non-linear system was done by Al'brekht who studied the analytic systems around 1961-1963 and discovered the optimal control as a formal power series by considering lia-

punov functions. In 1969-1975 the non-linear optimal feedback control problems was reexamined by Lukes [1] and Willemstein [2] and others. In [1] and [2] the authors developed their theory under the assumption that the states and the controls remain in a neighborhood of a fixed point (which without loss of generality can be the origin) where the system dynamics can be expanded in a power series.

In this research, the application of the optimal feedback control theory, developed in [1,2], is considered for study of the optimal regulation problem of a satellite. Based on this theory, a numerical technique, which solves the optimal regulation problem is developed. The effects of the feedback control on the system behaviour, designed on the basis of this technique is discussed. Further, the range in the state space R , over which the regulator can be used, without destabilizing the system, is also indicated.

An outline of the thesis is presented in what follows :

In chapter (I), a brief review of the theory of optimal regulator as developed in [1,2] is presented. This includes the proof of the existence of a unique optimal control in the case of free end problem. The procedure which has been used to determine the optimal feedback control is also indicated. Further the stability of the optimally regulated system is discussed. To the knowledge of the author, this question has been considered for the first time in this thesis.

In chapter (II) and chapter (III), the theory of optimal regulator, given in chapter (I), is used for the analysis and design of an optimal regulator for a satellite.

In chapter (II), the satellite regulation problem using a combination of reaction jets and flywheels is considered. An optimal feedback control model which minimizes the cost of fuel and energy is developed. Using such model, the size of the domain over which reaction jets are active and the corresponding fuel cost are discussed. The quality of regulation when reaction jets are shut off and flywheels activated is studied. Further, the problem encountered in computing the optimal control is briefly indicated.

In chapter (III), the satellite optimal regulation using reaction jets with flywheels having fixed angular velocities is studied. The effectiveness of linear, non-linear second order and third order regulators and their corresponding costs, under different initial perturbations, are compared. The range in the state space R^n over which these regulators are stable is obtained. Further, the major problem encountered in finding the optimal feedback control, using the previous theory, is discussed with more details.

Finally, in the concluding section recommendations for further work are also indicated.

Chapter II
THEORETICAL BACKGROUND

2.1. INTRODUCTION

Before proceeding to the formulation of Satellite optimal feedback regulation problems, the basic theorems of optimal feedback control which are developed in [1,2] will first be outlined. This outline is expected to provide an idea about the power and limitations of this theory. The proof of these results in the case of free end problem, and the methods which can be used to compute the optimal feedback control are given. Finally, the stability of the optimally regulated system, using Liapunov theory, is also investigated.

To formulate our problem, consider the control process in

\mathbb{R}^n
t

$$\dot{x} = F(x, u, t) \quad (2.1)$$

for $t \in [t_0, T]$, where x is the state of the process and u is the control.

The basic problem is to find a bounded feedback control $u(x, t)$ which minimizes the integral

$$J(x, u, t) = L(x(T)) + \int_t^T G(x(\theta), u(x(\theta), \theta), \theta) \quad (2.2)$$

for all initial states $x(\tau_0) = x_0$ in a neighborhood of the origin in \mathbb{R}^n and $\tau_0 \in (0, T]$. The solution of the above optimal control problem, when F is linear and G is quadratic, is well known (see [3]). The situation when F is non-linear and G is not only quadratic but contains some other higher order terms has been only recently considered by Lukes [1] and Willemsen [2]. The basic idea used in [1,2] to develop the non-linear optimal regulator theory can be summarized as follows: the function F is assumed to contain a linear term and higher order terms having small norms. Similarly, the function G is assumed to contain a quadratic term and higher order terms also having small norms. Under these assumptions the original non-linear regulation problem can be approximated by a linear-quadratic problem after omitting the higher order terms. This truncated problem is known to have a complete solution which is given by a linear feedback control law with the optimal feedback matrix gain obtained from the solution of a matrix Riccati equation. The non-linear regulation problem is then solved by using the solution of the truncated problem as a first approximation and then adding correction terms obtained by a recursive technique. This technique is developed and discussed in detail later in this chapter. The main results and their proof are also included.

NOTATIONS :

The inner product of two vectors x, y will be denoted by $x'y$, the length of a vector x by $|x| = \sqrt{x'x}$ and the transpose of a matrix M by M' . The notations $M > 0$ and $M \geq 0$ mean that M represents a positive definite and non-negative definite matrix, respectively.

2.2 BASIC THEORY OF OPTIMAL FEEDBACK REGULATORS2.2.1 ASSUMPTIONS

(i) Let the function $F(x, u, t)$ in (2.1) be given by

$$F(x, u, t) = A(t)x + B(t)u + f(x, u, t) \quad (2.3)$$

where $A(t)$ and $B(t)$ are continuous real matrix functions of dimension $n \times n$ and $n \times m$, respectively. The function $f(x, u, t)$ contains the higher order terms in x and u and is continuous with respect to t . Further, the function $f(x, u, t)$ can be expanded as a power series in (x, u) which starts with second order terms and converges about the origin, uniformly for $t \in [0, T]$.

(ii) Let the function $G(x, u, t)$ be expressed as

$$G(x, u, t) = x'Q(t)x + u'E(t)u + g(x, u, t) \quad (2.4)$$

where $Q(t)$ and $E(t)$ are continuous real matrix functions of dimension $n \times n$ and $m \times m$, respectively. The function $g(x, u, t)$

contains the higher order terms in (x,u) and is continuous with respect to t . Further, $g(x,u,t)$ can be expressed as a power series in (x,u) which starts with third order terms and converges about the origin, uniformly for $t \in [0,T]$.

(iii) $Q(t) \geq 0$ and $F(t) > 0$ (non-singular) for $t \in [0,T]$.

(iv) The function $L(x)$ in (1,2) is given by

$$L(x) = x'Mx + l(x) \tag{2.5}$$

where M is a real matrix of dimension $n \times n$. The function $l(x)$ is given as a power series in x which starts with third order terms and converges about the origin.

Finally, the class of feedback controls are given by

$$u(x,t) = D(t)x + h(x,t) \tag{2.6}$$

Here $D(t)$ is a continuous matrix function of dimension $m \times n$. The function $h(x,t)$ contains the higher order terms in x and is continuous with respect to t . furthermore, $h(x,t)$ is given as a power series in x which starts with second order terms and converges about the origin, uniformly for $t \in [0,T]$.

2.2.2 Class of admissible controls

The class of admissible controls (U) is given by all measurable, bounded and piecewise continuous functions defined on $\mathbb{R}^n \times [0,T]$ with values in \mathbb{R}^m and satisfying the properties :

$$(a) |x(x_0,t)| \leq r_1$$

and



$$(b) \quad |u(x, t)| \leq r_2$$

where $x(t)$ is the solution of the differential equation $\dot{x} = F(x, u(x, t), t)$ with the initial condition $x(t_0) = x_0$ that lies in the neighborhood N_u of the origin in F^n for $t \in [t_0, T]$, $t_0 \in (0, T]$ and $r_1, r_2 > 0$.

2.2.3 Definition of optimal feedback control

A feedback control $u_* \in U$ is called optimal if

$$J(x_0, u_*, t_0) \leq J(x_0, u, t_0)$$

for all $(x_0, t_0) \in N_u \times (0, T]$ and $u \in U$.

2.2.4 Theory of optimal feedback regulators

In this section, the theory of non-linear optimal feedback regulators is presented in Theorem 2.1 which is based on the solution of the corresponding truncated problem given in Theorem 2.2. For convenience, the proofs of these theorems are presented in several steps in the form of lemmas as given in Section 2.3.

THEOREM 2.1

For the control process in F^n ,

$$\dot{x} = F(x, u, t)$$

$$x(t_0) = x_0, \quad t_0 \in (0, T],$$

with the performance index,

$$J(x_0, u, t_0) = L(x(T)) + \int_{t_0}^T G(x(t), u(x, t), t) dt \quad (2.7)$$

where x is the response of the system (2.7), there exists a unique optimal feedback control $u_*(x, t)$. This feedback control is the unique solution of the functional equation

$$F_u(x, u(x, t), t) J_x(x, u, t) + G_u(x, u(x, t), t) = 0 \quad (2.8)$$

for small $|x|$ and $t \in [t_0, T]$. Furthermore,

$$u_*(x, t) = D_*(t)x + h_*(x, t),$$

$$J(x_0, u_*, t_0) = x_0' K_*(t_0) x_0 + j_*(x_0, t_0)$$

where the matrix functions $D_*(t)$ and $K_*(t) (\geq 0)$ depend only on the truncated problems defined in Theorem 2.1. The function h is as defined in (2.6) and the function j_* contains the higher order terms in x_0 .

THEOREM 2.2 (TRUNCATED PROBLEM).

For the special case in which the non-linear functions $l(x)$, $f(x, u, t)$ and $g(x, u, t)$ are equal to zero, the optimal control is given by

$$u_*(x, t) = D_*(t)x \quad (2.9)$$

where

$$D_*(t) = -R^{-1}(t) B'(t) K_*(t). \quad (2.9)'$$

The matrix $K_*(t) (\geq 0)$ is the solution of the Riccati equation (see Appendix A)

$$\begin{cases} \dot{K}(t) + Q(t) + K(t)A(t) + A^*(t)K(t) - K(t)E(t)F^{-1}(t)E^*(t)K(t) = 0 \\ K(T) = M. \end{cases} \quad (2.10)$$

Further, $D_*(t)x$ is a global optimal control in the sense that we can take $N_u = \mathbb{R}^n$ and $r_1, r_2 = \infty$ in the definition of optimal control. Finally,

$$J(x_0, u_*, t_0) = x_0^* K_*(t_0) x_0$$

for all $x_0 \in \mathbb{R}^n$, $t_0 \in (0, T]$.

2.3 CONSTRUCTION OF THE OPTIMAL FEEDBACK CONTROL

As indicated earlier, the proof of theorems 2.1 and 2.2 will be given with the aid of the following lemmas.

LEMMA 2.1

For each feedback control $u \in U$ having the form

$$u(x, t) = D(t)x + h(x, t),$$

there exists a neighborhood N_u of the origin in \mathbb{R}^n such that

$$(a) \quad J(x_0, u, t_0) = x_0^* \hat{K}(t_0) x_0 + j(x_0, t_0)$$

where $j(x_0, t_0)$ contains the higher order terms in x_0 and the matrix function $\hat{K}(t) (\geq 0)$ depends only on the truncated problem, and

(b) The functional equation (Bellman's equation)

$$F(x, u(x, t), t) + J_x(x, u, t) + J_t(x, u, t) + G(x, u(x, t), t) = 0$$

holds for all $x \in N_u$ and $t \in [t_0, T]$.

PRCCF.

Since the feedback control $u \in U$ is given by

$$u(x, t) = D(t)x + h(x, t),$$

equation (2.3) can be written as

$$\dot{x} = (A(t) + E(t)D(t))x + B(t)h(x, t) + f(x, u(x, t), t)$$

$$x(t_0) = x_0, \quad t_0 \in (0, T].$$

Define

$$A_*(t) \triangleq A(t) + B(t)D(t)$$

and

$$v(x, t) \triangleq B(t)h(x, t) + f(x, u, t)$$

then

$$\dot{x} = A_*(t)x + v(x, t)$$

(2.11)

$$x(t_0) = x_0.$$

From the definition of the class of the admissible controls, it is clear that in a neighborhood N_u of the origin in \mathbb{R}^n , the solution of (2.11) exists on the interval $[t_0, T]$. Since the function $v(x, t)$ contains the higher order terms in

x and it is bounded (since the functions $h(x,t)$ and $f(x,u,t)$ are bounded as indicated in section 2.2.1) there exists a function $\theta(x)$, with the property $\lim_{|x| \rightarrow 0} \theta(x) = 0$, such that

$$|v(x(t), t)| \leq \theta(x(t)) |x(t)| \quad \text{for } t \in [t_0, T].$$

Let $\phi(t)$ be the fundamental matrix solution of the linear equation $\dot{x} = A_*(t)x$ (ϕ is a non-singular matrix function of dimension $n \times n$ which satisfies the differential equation $\dot{\phi}(t) = A_*(t)\phi(t)$, $\phi(t_0) = I$ for $t \in [t_0, T]$). Hence, the solution of (2.11) is given by the solution of the non-linear Volterra integral equation

$$x(t) = \phi(t)\phi^{-1}(t_0)x_0 + \int_{t_0}^t \phi(t)\phi^{-1}(s)v(x(s), s) ds \quad (2.12)$$

$t \in [t_0, T]$. The continuity of ϕ on the interval $[t_0, T]$ implies that $\phi(t)\phi^{-1}(s)$ is bounded for all $t, s \in [t_0, T]$. Therefore, there exists some constant $m > 0$ such that

$$|\phi(t)\phi^{-1}(s)| \leq m \quad \text{for } (t, s) \in [t_0, T] \times [t_0, T].$$

Hence

$$|x(t)| \leq m|x_0| + \int_{t_0}^t m|\theta(x(s))| |x(s)| ds.$$

By choosing $\delta > 0$ such that $|e(x(s))| \leq 1$ for $|x_0| < \delta$, and $s \in [t_0, T]$. It follows that

$$|x(t)| < m|x_0| + \int_{t_0}^t m|x(s)| ds.$$

Using Gronwall inequality, it follows from this that

$$|x(t)| \leq m|x_0| \exp(m(t-t_0)) \quad (2.13)$$

for $|x_0| < \delta$, $t \in [t_0, T]$.

Since the function $v(x(t), t)$ in (2.12) contains the higher order terms in x starting with second order terms, in view of (2.13), we can conclude that there exists a constant $d > 0$ such that $|v(x(t), t)| \leq d|x(t)|^2$, for $t \in [t_0, T]$. Therefore, for all $t \in [t_0, T]$,

$$|x(t) - \phi(t)\phi^{-1}(t_0)x_0| < m \int_{t_0}^t |v(x(s), s)| ds < md \int_{t_0}^t |x(s)|^2 ds.$$

Substituting (2.13) into the previous inequality, it is clear that

$$x(t) = \phi(t)\phi^{-1}(t_0)x_0 + O(|x_0|^2) \quad (2.14)$$

uniformly for $t \in [t_0, T]$. Hence, from (2.4) and the expression for u we have

$$\begin{aligned}
 G(x(t), u(x(t), t), t) &= x(t)' Q(t) x(t) + x(t)' D'(t) R(t) D(t) x(t) \\
 &\quad + O(|x(t)|^3) \\
 &= x_0' (\phi^{-1}(t_0))' \phi(t)' [Q(t) + D'(t) R(t) D(t)] \phi(t) \phi^{-1}(t_0) x_0 \\
 &\quad + O(|x_0|^3) \quad (2.15)
 \end{aligned}$$

uniformly for $t \in [t_0, T]$. Furthermore, from (2.5) we get

$$\begin{aligned}
 L(x(T)) &= x(T)' M x(T) + O(|x(T)|^3) \\
 &= x_0' (\phi^{-1}(t_0))' \phi(T)' M \phi(T) \phi^{-1}(t_0) x_0 + O(|x_0|^3) \quad (2.16)
 \end{aligned}$$

Substituting (2.15) and (2.16) into (2.2) we obtain

$$J(x_0, u, t_0) = x_0' \hat{K}(t_0) x_0 + O(|x_0|^3)$$

where

$$\begin{aligned}
 \hat{K}(t_0) &= (\phi^{-1}(t_0))' \phi(T)' M \phi(T) \phi^{-1}(t_0) \\
 &\quad + \int_{t_0}^T (\phi^{-1}(t_0))' \phi(t)' [Q(t) + D'(t) R(t) D(t)] \phi(t) \phi^{-1}(t_0) dt.
 \end{aligned}$$

It is clear that $\hat{K}(t_0) \geq 0$ and $\hat{K}(T) = M$. This proves part (a) of the lemma.

Let $x(t)$ denote the solution of the differential equation $\dot{x}(t) = F(x(t), u(x(t), t), t)$ with $x(t_0) = x_0 \in N_u$ for arbitrary $t_0 \in (0, T]$ such that the trajectory $x(t)$ lies in the neighborhood N_u of the origin in E^n for all $t \in [t_0, T]$. Then

$$J(x(t), u, t) = L(x(T)) + \int_{t_0}^T G(x(\theta), u(x(\theta), \theta), \theta) d\theta$$

Since the function $G(x(t), u(x(t), t), t)$ is defined on $N_u \times U \times [t_0, T]$, bounded and analytic, then

$$-J_t(x(t), u, t) = F(x(t), u(x(t), t), t)' J_x(x(t), u, t) + G(x(t), u(x(t), t), t)$$

where J_t and J_x denote the partials of J with respect to t and x , respectively.

The previous equation holds for any $x_0 \in N_u$ and also holds along the trajectory $x(t)$, $t \in [t_0, T]$. This completes the proof of the lemma. \square

LEMMA 2.2

The functional equation

$$F_u(x, u, t)' \psi + G_u(x, u, t) = 0 \quad (2.18)$$

has a solution $u = u_*(x, \psi, t)$ near the origin in \mathbb{R}^n for which

$$(a) \quad u_*(0, 0, t) = 0 \quad \text{for } t \in [t_0, T]$$

and

$$(b) \quad u_*(x, \psi, t) = -1/2 E^{-1}(t) E'(t) \psi + h_*(x, \psi, t)$$

where $h_*(x, \psi, t)$ contains the higher order terms in (x, ψ) .

PROOF

For fixed but arbitrary $x, \psi \in \mathbb{R}^n$, define

$$H(x, \psi, u, t) = F(x, u, t)' \psi + G(x, u, t) \quad (2.19)$$

where $u \in \mathbb{R}^m$ and $t \in [0, T]$. We wish to show that there exists a function $u_*(x, \psi, t)$ such that $H_u(x, \psi, u_*, t) = 0$, and u_* has the form as stated in (b).

Substituting (2.3) and (2.4) into (2.19) we obtain

$$H(x, \psi, u, t) = [A(t)x + B(t)u + f(x, u, t)]' \psi + x' Q(t)x + u' P(t)u + g(x, u, t). \quad (2.20)$$

Taking the second partial of H with respect to u , we have

$$H_{uu}(x, \psi, u, t) = 2P(t) + \beta_{uu} \quad (2.21)$$

where $\beta = (f'(x, u, t)\psi + g(x, u, t))$.

Since $P(t) > 0$ and the functions f, g have small norms near the origin, it is clear from (2.21) that $H_{uu}(x, \psi, u, t) > 0$.

Therefore, by the implicit function theorem, it follows that there exists a function $u_* : \mathbb{R}^n \times \mathbb{R}^n \times [0, T] \rightarrow \mathbb{R}^m$ such that $H_u(x, \psi, u_*, t) = 0$. Thus from (2.20) we have

$$B'(t)\psi + 2P(t)u_*(x, \psi, t) + (\text{higher order terms in } (x, \psi)) = 0$$

for all x, ψ in \mathbb{R}^n . This completes the proof of the lemma. \square

LEMMA 2.3

Suppose there exists a feedback control $u_0 \in U$ with the form

$$u_0(x, t) = D_*(t)x + h_*(x, t)$$

satisfying the non-linear functional equation

$$F_u(x, u_0(x, t), t)' J_x(x, u_0(x, t)) + G_u(x, u_0(x, t), t) = 0 \quad (2.22)$$

for small $|x|$ and $t \in [t_0, T]$. Then

(a) u_0 is the unique optimal feedback control,

$$(b) u_0(x, t) = -E^{-1}(t) B'(t) K_*(t) x + C(|x|^2)$$

and

$$(c) J(x_0, u_0, t_0) = x_0' K_*(t_0) x_0 + j_*(x_0, t_0)$$

for $t \in [t_0, T]$ where $K_*(t)$ is the solution of the Riccati equation and the function $j_*(x_0, t_0)$ contains the higher order terms in x_0 starting with third order.

PROOF.

Consider the following real valued function defined for (x, u) near the origin in the space F^{n+m} and $t \in [t_0, T]$:

$$Q(x, u(x, t), t) = F(x, u(x, t), t)' J_x(x, u_0, t) + J_t(x, u_0, t) + G(x, u(x, t), t).$$

By lemma (2.1), $Q(x, u_0(x, t), t) = 0$ near $x=0$ and for $t \in [t_0, T]$.

Let $Q_u(x, u_0(x, t), t) = 0$ near $x=0$ and for $t \in [t_0, T]$. Since $Q_{uu}(0, 0, t) = 2E(t) + \beta_{uu}$, (where β is as given in (2.21)) is positive definite on $[t_0, T]$ for small $|x|$ and $|u|$, the function Q attains its minimum at u_0 . Hence

$$0 = Q(x, u_0(x, t), t) \leq Q(x, u_1(x, t), t), \quad \text{for } u_1 \in U.$$

Therefore,

$$F(x, u_1(x, t), t)' J_x(x, u_0, t) + J_t(x, u_0, t) + G(x, u_1(x, t), t) > 0 \quad (2.23)$$

for $u_1 \in U$. Let N_* be a neighborhood of the origin in \mathbb{R}^n such that for each $x_0 \in N_*$ the solution $x_*(t)$ of the differential equation $\dot{x} = F(x, u_0(x, t), t)$, $x(t_0) = x_0$, exists for each $t \in [t_0, T]$, and that $|x_*(t)| \leq r_1$ and $|u_0(x_*(t), t)| \leq r_2$. Further, let $u_1 \in U$ be an arbitrary feedback control such that the solution $x_1(t)$ of $\dot{x} = F(x, u_1(x, t), t)$, $x(t_0) = x_0$, is defined on $[t_0, T]$, and satisfies

$|x_1(t)| \leq r_1$ and $|u_1(x_1(t), t)| \leq r_2$, for $x_0 \in N_*$. Then

$$\int_{t_0}^T [F(x_1(t), u_1(x_1(t), t), t) \cdot J_x(x_1(t), u_0(x_*(t), t), t)$$

$$+ J_t(x_1(t), u_0(x_*(t), t), t) + G(x_1(t), u_1(x_1(t), t), t)] dt > 0.$$

Hence

$$\int_{t_0}^T \frac{d}{dt} J(x_1(t), u_0(x_*(t), t), t) dt + \int_{t_0}^T G(x_1(t), u_1(x_1(t), t), t) dt > 0.$$

Integrating the first term, we obtain

$$J(x_1(T), u_0(x_*(T), T), T) - J(x_0, u_0(x_0, t_0))$$

$$+ \int_{t_0}^T G(x_1(t), u_1(x_1(t), t), t) dt > 0$$

and since $G \geq 0$, this implies that

$$J(x_0, u_0, t_0) < J(x_0, u_1, t_0)$$

for all u_1 in the admissible class. Therefore, u_0 is the unique optimal control.

By lemma 2.2, u_0 can be expressed as

$$u_0(x,t) = -R^{-1}(t)B'(t)J_x(x,u_0,t) + O(|x|^2)$$

uniformly for $t \in [t_0, T]$. But from Lemma 2.1 we have,

$$J_x(x,u_0,t) = 2\hat{K}(t)x + O(|x|^2).$$

Thus,

$$u_0(x,t) = -R^{-1}(t)B'(t)\hat{K}(t)x + O(|x|^2) \quad (2.24)$$

uniformly for $t \in [t_0, T]$. From Lemma 2.1

$$Q(x,u_0(x,t),t) = 0 \quad (2.25)$$

for small $|x|$ and $t \in [t_0, T]$ and the matrix function $\hat{K}(t)$ in (2.24) is the solution of the Riccati equation with $\hat{K}(T) = M$. Therefore, by the uniqueness of its solution, $\hat{K}(t) = K_*(t)$ on $[t_0, T]$. This implies that

$$u_0(x,t) = -R^{-1}(t)B'(t)K_*(t)x + O(|x|^2)$$

and

$$J(x_0, u_0, t_0) = x_0^T K_*(t_0) x_0 + O(|x_0|^3)$$

for all $t_0 \in (0, T]$ and $x_0 \in N_*$. \square

Since the proof of Theorem 2.1 mainly depends on the truncated problem, the proof of Theorem 2.2 will be given first.

PROOF OF THEOREM 2.2

In the special case where the functions $f(x,u,t)$, $g(x,u,t)$ and $l(x)$ are equal to zero, the optimal feedback control $u_*(x,t)$ is given by (see Appendix A)

$$u_*(x,t) = D_*(t) x$$

where $D_*(t) = -R^{-1}(t) B'(t) K_*(t)$ and the matrix $K_*(t) (\geq 0)$ is the solution of the Riccati equation

$$\dot{K}(t) + Q(t) + K(t) A(t) + A'(t) K(t) - K(t) E(t) R^{-1}(t) E'(t) K(t) = 0,$$

$$K(T) = M.$$

Hence by lemma 2.1 the functional equation

$$x' [\dot{K}_*(t) + Q(t) + K_*(t) A(t) + A'(t) K_*(t) - K_*(t) B(t) R^{-1}(t) E'(t) K_*(t)] x = 0$$

with the boundary condition

$$K_*(T) = M$$

holds for all $x \in \mathbb{R}^n$ and $t \in [t_0, T]$. By rearranging the previous equation we have

$$x' \dot{K}_*(t) x + 2 [(A(t) - B(t) R^{-1}(t) E'(t) K_*(t)) x]' K_*(t) x + x' Q(t) x + x' K_*(t) B(t) R^{-1}(t) E'(t) K_*(t) x = 0.$$

Using the expression for $D_*(t)$ given above, it follows that

$$\begin{aligned} & x' \dot{K}_*(t) x + 2[(\lambda(t) + B(t)D_*(t))x]' K_*(t) x \\ & + x' Q(t) x + x' D_*'(t) F(t) D_*(t) x = 0 \end{aligned} \quad (2.26)$$

for all $(x, t) \in \mathbb{R}^n \times [0, T]$.

For the truncated problem with the optimal control $u_*(t) = D_*(t)x$ included, we have

$$\begin{aligned} \dot{y} &= A(t)y(t) + B(t)D_*(t)y(t) = (A(t) + B(t)D_*(t))y(t) \\ y(t_0) &= x \end{aligned}$$

and

$$\begin{aligned} J(x_0, u_*, t_0) &= \int_{t_0}^T [y'(\tau)Q(\tau)y(\tau) + y'(\tau)D_*'(\tau)R(\tau)D_*(\tau)y(\tau)] d\tau \\ &\quad + y'(T)My(T) \end{aligned}$$

where y is the optimal trajectory starting from any arbitrary point $(x_0, t_0) \in \mathbb{R}^n \times [0, T]$. Since the expression (2.26) holds for any $(x, t) \in \mathbb{R}^n \times [0, T]$, it is clear that this expression holds also along the optimal trajectory. Hence

$$\begin{aligned} & y'(t)\dot{K}_*(t)y(t) + 2(\lambda(t) + B(t)D_*(t))y(t)' K_*(t)y(t) \\ & + y'(t)Q(t)y(t) + y'(t)D_*'(t)R(t)D_*(t)y(t) = 0 \end{aligned}$$

for $t \in [t_0, T]$, which is equivalent to

$$\begin{aligned} & y'(t)\dot{K}_*(t)y(t) + 2\dot{y}'(t)K_*(t)y(t) \\ & + [y'(t)Q(t)y(t) + y'(t)D_*'(t)R(t)D_*(t)y(t)] = 0 \end{aligned}$$

for $t \in [t_0, T]$. Integrating the previous expression over the interval $[t_0, T]$ and noting that the expression within the parenthesis is the cost integral given above, we have

$$\int_{t_0}^T \frac{d}{dt} (y'(t) K_*(t) y(t)) dt + \int_{t_0}^T [y'(t) Q(t) y(t) + y'(t) D_*'(t) R(t) D_*(t) y'(t)] dt = 0$$

Integrating the first term by parts and recalling that $K_*(T) = M$, we have

$$y'(T) M y(T) + \int_{t_0}^T [y'(t) Q(t) y(t) + y'(t) D_*'(t) R(t) D_*(t) y'(t)] dt - x_0' K_*(t_0) x_0 = 0$$

which is equivalent to

$$J(x_0, u_*, t_0) = x_0' K_*(t_0) x_0$$

Since (x_0, t_0) is any arbitrary point in $\mathbb{R}^n \times [t_0, T]$, the previous equality holds for all (x_0, t_0) .

Since the question of stability is treated for a more general problem in section 2.5, the proof of the global stability of linear feedback control will be postponed until then. This completes the proof of the Theorem. \square

Let $(x_0, t_0) \in \mathbb{R}^n \times [0, T]$, and consider the optimality system

$$\dot{x} = \frac{\partial H}{\partial \psi} = F(x(t), u_*(x(t), \psi(t), t), t), \quad (2.27)$$

$$\dot{\psi} = -\frac{\partial H}{\partial x} = -F_x(x(t), u_*(x(t), \psi(t), t), t) \cdot \psi(t) - G_x(x(t), u_*(x(t), \psi(t), t), t)$$

with the boundary conditions

$$x(t_0) = x_0 \quad \text{and} \quad \psi(T) = -L_x(x(T))$$

over the interval $[t_0, T]$. Here the Hamiltonian H is evaluated along the control u_* (see Lemma 2.2) and the corresponding state and costate trajectories x and ψ .

In order to complete the proof of Theorem 2.1, it is sufficient to prove that

(i) The optimality system (2.27) has a solution. (this will be indicated in Lemma 2.4),

and that

(ii) Along the solution trajectory of the optimality system, the cost functional J satisfies the property

$$J_x(x(t), u, t) = \psi(t)$$

for all $t \in [t_0, T]$.

LEMMA 2.4

The optimality system (2.27) has a solution $(x_*(t), \psi_*(t))$ on the interval $[t_0, T]$ and for small $|x|$, and

$$\psi_*(t) = 2K_*(t)x_*(t) + O(|x_*(t)|^2)$$

uniformly for $t \in [t_0, T]$.

EPCCF

Using (2.3) and (2.4), equation (2.27) can be written as

$$\begin{bmatrix} \dot{x} \\ \dot{\psi} \end{bmatrix} = \begin{bmatrix} A(t) & -1/2 B(t) R^{-1}(t) B'(t) \\ -2Q(t) & -A'(t) \end{bmatrix} \begin{bmatrix} x \\ \psi \end{bmatrix} + h_0(x, \psi, t) \quad (2.28)$$

where the function $h_0(x, \psi, t)$ contains the higher order terms in (x, ψ) . Let us first prove that the Lemma holds for the truncated case. For the truncated problem, system (2.28) reduces to

$$\begin{bmatrix} \dot{x} \\ \dot{\psi} \end{bmatrix} = \begin{bmatrix} A(t) & -1/2 B(t) R^{-1}(t) B'(t) \\ -2Q(t) & -A'(t) \end{bmatrix} \begin{bmatrix} x \\ \psi \end{bmatrix} \quad (2.29)$$

The system (2.29) must be solved with the boundary conditions

$$x(t_0) = x_0, \text{ for arbitrary } x_0 \text{ near the origin in } \mathbb{R}^n, \\ t \in [t_0, T],$$

and

$$\psi(t) = 2Mx(T) \quad (2.30)$$

where $2Mx(T) = L_x(x(T))$ (see section 2.5). The optimal feedback control $u_*(x, t)$, for the truncated problem, is given by (see Lemma 2.2(b) and Lemma 2.3(b))

$$u_*(x, t) = -B^{-1}(t)B'(t)K_*(t)x = -1/2 F^{-1}(t)E'(t)\Psi$$

where,

$$\Psi(x, t) = 2K_*(t)x \quad (2.31)$$

Since $A(t), B(t), B'(t) (>0)$ and $C(t)$ are continuous bounded matrix functions, there exists a solution $(x_*(t), \Psi_*(t))$ for (2.29) satisfying (2.30) for all $t \in [t_0, T]$. This linear system can be considered as a final value problem with the boundary conditions $x(T) = x_{*T}$ and $\Psi(T) = \Psi_{*T}$. In this case, the solution can be written in the following form

$$\begin{bmatrix} x(t) \\ \Psi(t) \end{bmatrix} = \phi(t) \phi^{-1}(T) \begin{bmatrix} x_{*T} \\ \Psi_{*T} \end{bmatrix} \quad (2.32)$$

where $\phi(t)$ is a fundamental matrix solution of (2.29).

The matrix $\phi(t) \phi^{-1}(T)$ can be written as

$$\phi(t) \phi^{-1}(T) = \begin{bmatrix} \theta_{11}(t, T) & \theta_{12}(t, T) \\ \theta_{21}(t, T) & \theta_{22}(t, T) \end{bmatrix} \quad (2.33)$$

Substituting (2.33) into (2.32) we obtain

$$x(x_{*T}, \psi_{*T}, t) = e_{11}(t, T)x_{*T} + e_{12}(t, T)\psi_{*T}$$

$$\psi(x_{*T}, \psi_{*T}, t) = e_{21}(t, T)x_{*T} + e_{22}(t, T)\psi_{*T}$$

where we have included the terminal values x_{*T} and ψ_{*T} in the arguments of x and ψ to indicate their dependence on these parameters. From the above two equations and (2.30), we have

$$x(x_{*T}, 2Mx_{*T}, t) = (e_{11}(t, T) + 2e_{12}(t, T)M)x_{*T}$$

and at $t = t_0$, $x(x_{*T}, 2Mx_{*T}, t_0) = x_0$. In other words, for all $x_0 \in \mathbb{R}^n$ and $t \in [t_0, T]$ there exists $x_{*T} \in \mathbb{R}^n$ such that

$$(e_{11}(t_0, T) + 2e_{12}(t_0, T)M)x_{*T} = x_0$$

which indicates that the matrix $(e_{11}(t_0, T) + 2e_{12}(t_0, T)M)$ is nonsingular. Now consider the nonlinear system (2.28) as a final value problem with the boundary conditions $x(T) = x_{*T}$, $\psi(T) = \psi_{*T}$. In view of (2.32) the solution of this system can be written as

$$\begin{bmatrix} x(t) \\ \psi(t) \end{bmatrix} = \phi(t) \phi^{-1}(T) \begin{bmatrix} x_{*T} \\ \psi_{*T} \end{bmatrix} + v(x_{*T}, \psi_{*T}, t)$$

where $v(x_{*T}, \psi_{*T}, t)$ contains the higher order terms in (x_{*T}, ψ_{*T}) starting with second order terms. By arguments si-

ilar to those used in Lemma 2.1, it follows from (2.32) and (2.33) that

$$x(x_{*T}, \Psi_{*T}, t) = e_{11}(t, T)x_{*T} + e_{12}(t, T)\Psi_{*T} + O\left(\begin{array}{c} |x_{*T}|^2 \\ |\Psi_{*T}|^2 \end{array}\right)$$

$$\Psi(x_{*T}, \Psi_{*T}, t) = e_{21}(t, T)x_{*T} + e_{22}(t, T)\Psi_{*T} + O\left(\begin{array}{c} |x_{*T}|^2 \\ |\Psi_{*T}|^2 \end{array}\right)$$

uniformly for $t \in [t_0, T]$.

We wish to prove that for arbitrary $x_0 \in \mathbb{R}^n$ with small norm, there exists a vector $x_{*T} \in \mathbb{R}^n$ such that $x(x_{*T}, L_x(x_{*T}), t_0) = x_0$. Define the function S as

$$S(x_0, x_{*T}) = x(x_{*T}, L_x(x_{*T}), t_0) - x_0$$

Since \tilde{L} is at least quadratic in x , it follows that

$$S(C, C) = 0 \quad \text{and}$$

$$S_{x_{*T}}(C, C) = (e_{11}(t_0, T) + 2e_{12}(t_0, T)M)$$

where $S_{x_{*T}}(C, C)$ is nonsingular. Therefore, it follows from implicit function theorem, that there exists a neighborhood C of the origin in \mathbb{R}^n and a function $\tilde{x}_T: C \rightarrow \mathbb{R}^n$ such that

$$(i) \quad \tilde{x}_T(x_0) = 0 \quad \text{for } x_0 = 0$$

$$(ii) \quad S(x_0, \tilde{x}_T(x_0)) = 0 \quad \text{for } x_0 \in C$$

Hence $x(\tilde{x}_T(x_0), L_x(\tilde{x}_T(x_0)), t_0) = x_0$. Consequently, the optimality system (2.26), and hence (2.27), has a solution on the interval $[t_0, T]$ for small $|x_0|$ with the property

$$\Psi_*(x, t) = 2K_*(t)x_*(t) + O(|x_*(t)|^2)$$

uniformly for $t \in [t_0, T]$. This completes the proof of the Lemma. \square

PROOF OF THEOREM 2.1

According to lemma 2.3 it remains to establish the existence of a feedback control $u_* \in U$ which satisfies the functional equation (2.8). Define

$$u_*(x, t) \triangleq u_*(x, \psi_*(x, t), t)$$

where $\psi_*(x, t)$ is the solution of (2.27) and $u_*(x, \psi, t)$ is as defined in Lemma 2.2. Then

$$\begin{aligned} u_*(x, t) &= -\frac{1}{2} R^{-1}(t) B^T(t) \psi_*(x, t) + C(|x|^2) \\ &= -R^{-1}(t) B^T(t) K_*(t) x + C(|x|^2) \end{aligned}$$

uniformly for $t \in [t_0, T]$ and x near the origin in F^n . Let $s \in [t_0, T]$ be fixed and choose $y \in F^n$ near the origin such that the solution of the system $\dot{x} = F(x, u_*(x, t), t)$, with $x(s) = y$ exists on $(s, T]$. Further, let $|x_0|$ be so small such that the solution of (2.27) exists. From the continuity and analyticity of the function G , it follows that

$$\frac{\partial}{\partial y} J(y, u_*, s) = \int_s^T \frac{\partial}{\partial y} G(x(t), u_*(x(t), t), t) dt + \frac{\partial}{\partial y} I(x(T))$$

$$= \int_s^T \left[\frac{\partial x}{\partial y} \frac{\partial G(x(t), u_*(x(t), t), t)}{\partial x} \right.$$

$$\left. \frac{\partial u_*}{\partial y} \frac{\partial G(x(t), u_*(x(t), t), t)}{\partial u_*} \right] dt + \frac{\partial}{\partial y} I(x(T))$$

From (2.27) we have

$$\begin{aligned} \frac{\partial J(y, u_*, s)}{\partial y} &= \int_s^T \left[\frac{\partial x}{\partial y} (-\dot{\Psi}_*(x(t), t)) \right. \\ &\quad \left. - \left(\frac{\partial F(x(t), u_*(x(t), t), t)}{\partial x} \right) \Psi_*(x(t), t) \right. \\ &\quad \left. + \frac{\partial u_*}{\partial y} \frac{\partial G(x(t), u_*(x(t), t), t)}{\partial u_*} \right] dt + \frac{\partial}{\partial y} I(x(T)) \end{aligned}$$

From Lemma 2.3, it follows that

$$\begin{aligned} F_u(x(t), u_*(x(t), t), t) \cdot \Psi_*(x(t), t) \\ + G_u(x(t), u_*(x(t), t), t) = 0 \end{aligned}$$

Hence,

$$\begin{aligned}
 \frac{\partial J(y, u_*, s)}{\partial y} &= - \int_s^T \frac{\partial x}{\partial y} \frac{d}{dt} \Psi_*(x(t), t) dt \\
 &- \int_s^T \left(\frac{\partial x}{\partial y} \frac{\partial F(x(t), u_*(x(t), t), t)}{\partial x} \right) \Psi_*(x(t), t) dt \\
 &- \int_s^T \left(\frac{\partial u_*}{\partial y} \frac{\partial F(x(t), u_*(x(t), t), t)}{\partial u_*} \right) \Psi_*(x(t), t) dt + \frac{\partial}{\partial y} L(x(T)) \\
 &= - \int_s^T \frac{d}{dt} \left[\frac{\partial x}{\partial y} \Psi_*(x(t), t) \right] dt + \int_s^T \left[\frac{d}{dt} \frac{\partial x}{\partial y} \right] \Psi_*(x(t), t) dt \\
 &- \int_s^T \left[\frac{\partial x}{\partial y} \frac{\partial F(x(t), u_*(x(t), t), t)}{\partial x} \right] \Psi_*(x(t), t) dt + \frac{\partial}{\partial y} L(x(T)) \\
 &- \int_s^T \left[\frac{\partial u_*}{\partial y} \frac{\partial F(x(t), u_*(x(t), t), t)}{\partial u_*} \right] \Psi_*(x(t), t) dt
 \end{aligned}$$

Thus,

$$\begin{aligned}
\frac{\partial J(y, u_*, s)}{\partial y} &= - \frac{\partial x}{\partial y} \Psi_*(x(t), t) \Big|_s^T + \frac{\partial}{\partial y} I(x(T)) \\
&- \int_s^T \left[\frac{\partial}{\partial y} F(x(t), u_*(x(t), t), t) \right] \Psi_*(x(t), t) dt \\
&+ \int_s^T \left[\frac{\partial}{\partial y} F(x(t), u_*(x(t), t), t) \right] \Psi_*(x(t), t) dt \\
&= \frac{\partial x(s)}{\partial y} \Psi_*(x(s), s) - \frac{\partial x(T)}{\partial y} \Psi_*(x(T), T) + \frac{\partial}{\partial y} I(x(T)) \\
&= \Psi_*(y, s) - \frac{\partial x(T)}{\partial y} L_x(x(T)) + \frac{\partial}{\partial y} I(x(T)) \\
&= \Psi_*(y, s).
\end{aligned}$$

Therefore, $J_y(y, u_*, s) = \Psi_*(y, s)$ for small $|y|$ and $s \in [t_0, T]$. Since this is true for all $y \in \mathbb{R}^n$ having small norm and $s \in [t_0, T]$, then the functional equation

$$F_u(x, u_*(x, t), t) + J_x(x, u_*(x, t)) + G_u(x, u_*(x, t), t) = 0$$

holds for small $|x|$ and $t \in [t_0, T]$. This implies that $u_*(x, t)$ satisfies the functional equation (2.8). This completes the proof of Theorem 2.1. \square

2.4 A METHOD FOR CALCULATING THE OPTIMAL CONTROL

In this section, we shall use the following notation: if $S(x)$ is a power series in x then the i th order term will be denoted by $S^{(i)}(x)$. Further, the cost functional $J(x, u_*, t)$ is defined as

$$\begin{aligned} J(x, u_*, t) &= J_*(x, t) = \int_t^T G(y^{u_*}(\theta), u_*(y^{u_*}(\theta), \theta), \theta) d\theta \\ &= \inf_u \int_t^T G(y^u(\theta), u(y^u(\theta), \theta), \theta) d\theta \end{aligned}$$

where y^u satisfies the initial value problem

$$\begin{aligned} \dot{y}(\theta) &= F(y(\theta), u(y(\theta), \theta), \theta) \\ y(t) &= x, \quad \theta \geq t. \end{aligned}$$

Here y^{u_*} is the solution of the above system corresponding to u_* .

Using theorem 2.1, the optimal control law $u_*(x, t)$ and the cost functional $J_*(x, t)$ can be expanded in a power series as

$$\begin{aligned} u_*(x, t) &= u_*^{(1)}(x, t) + u_*^{(2)}(x, t) + \dots \\ J_*(x, t) &= J_*^{(2)}(x, t) + J_*^{(3)}(x, t) + \dots \end{aligned} \tag{2.34}$$

where the lowest order terms in the previous equation are given by

$$\begin{aligned} (1) \quad u_* (x, t) &= -\int_{t_0}^t B'(t) K_*(t) x \, dt, \\ (2) \quad J_* (x, t) &= x' K_*(t) x \end{aligned} \tag{2.35}$$

and $K_*(t)$ is the solution of matrix Riccati equation backward in time (with $K(T) = M$ and $t \in [t_0, T]$). The method used in [1,2] to compute the higher order terms in series (2.34) is based on the fact that $u_*(x, t)$ is the solution of the following two functional equations

$$F(x, u_*(x, t), t) + [J_*(x, t)]_x + [J_*(x, t)]_t + G(x, u_*(x, t), t) = 0, \tag{2.36}$$

$$F_u(x, u_*(x, t), t) + [J_*(x, t)]_x + G_u(x, u_*(x, t), t) = 0.$$

Substituting (2.34) into (2.36) and equating the coefficients of similar order, $J_*(x, t)$ and $u_*(x, t)$ can be calculated using the following equations

$$\begin{aligned}
 & [A_*(t)x]' [J_*^{(m)}(x,t)]_x + [J_*^{(m)}(x,t)]_t = \\
 & - \sum_{k=3}^m [B(t)u_*^{(m-k+1)}(x,t)]' [J_*^{(k)}(x,t)]_x \\
 & - \sum_{k=2}^{m-1} [f(x, u_*(x,t), t)]' [J_*^{(k)}(x,t)]_x \\
 & - 2 \sum_{k=2}^{[(m-1)/2]} [u_*^{(k)}(x,t)]' F(t) \dot{u}_*^{(m-k)}(x,t) \\
 & - [u_*^{(m/2)}(x,t)]' F(t) u_*^{(m/2)}(x,t) - g(x, u_*(x,t), t) ,
 \end{aligned} \tag{2.37}$$

$$\begin{aligned}
 u_*^{(k)}(x,t) = & -1/2F(t) (B'(t)) [J_*^{(k+1)}(x,t)]_x \\
 & + \sum_{j=1}^{k-1} f(x, u_*^{(j)}(x,t), t) [J_*^{(k-j+1)}(x,t)]_x \\
 & + g_u^{(k)}(x, u_*(x,t), t)
 \end{aligned} \tag{2.38}$$

where $m=3,4,5,\dots$, and $k=2,3,4,\dots$.

Here the matrix function $A_*(t) = A(t) + B(t)E_*(t)$; $[k]$ denotes the integer part of k . Further, the term $u_*^{(m/2)}$ to be omitted for odd values of m .

Using equations (2.37) and (2.38), a power series of $u_*(x,t)$ and $J_*(x,t)$ can be generated. The sequence

$$[u_*^{(1)}, u_*^{(2)}, \dots, u_*^{(m-2)}, J_*^{(2)}, \dots, J_*^{(m-1)}]$$

determines $J_*^{(m)}$ (for all $m \geq 3$) in (2.37) by solving a system of differential equations. The sequence

$$[u_*^{(1)}, u_*^{(2)}, \dots, u_*^{(k-1)} ; J_*^{(2)}, \dots, J_*^{(k+1)}]$$

determines $u_*^{(k)}$ in (2.38), for all $k \geq 2$.

2.5 STABILITY OF OPTIMALLY REGULATED SYSTEM

Before formulating the satellite optimal feedback regulation problem, the stability of the optimally regulated system $\dot{x} = F(x(t), u_*(x, t), t)$ is investigated. This question can be solved with the aid of the result developed by Liapunov. For convenience, this result will be presented first without proof. Then by Lemma 2.5, the asymptotic stability of the system will be indicated.

Consider the following system (in $F^n X[0, T]$) ,

$$(s) \begin{cases} \dot{x} = F(x, t) , \\ x(0) = x_0 = 0 \end{cases}$$

where for $x=0$, we assume that $F(0, t) \equiv 0$.

It is known that if there exists a scalar function (Liapunov function)

$V(x, t) \in C^{1,1}(F^n X[0, T])$ which satisfies the properties

- (i) $V(0, t) = 0$ for $x = 0$,
- (ii) $V(x, t) > 0$ for $x \neq 0$,
- (iii) $\dot{V}(x, t) = V_t(x, t) + (V_x(x, t), H(x, t)) < 0$

then system (s) is asymptotically stable about the origin.

With the aid of the previous result, we can show that the optimally regulated system (2.7) is necessary asymptotically stable. This is indicated by the following lemma.

LEMMA 2.5

Consider the system (2.7) and suppose there exists a feedback control law $u_*(x, t)$ which minimizes the cost functional (2.7)'. Further, suppose the value function

$$J_*(x, t) = \inf_u \left[\int_t^T G(y(e), u(y(e), e), e) de \right],$$

with y being the solution of the initial value problem (2.7) with $y(t) = x$, satisfies the Bellman's equation

$$\frac{\partial}{\partial t} J_*(x, t) + \inf_v [(F(x, v(x, t), t), [J_*(x, t)]_x) + G(x, v(x, t), t)] = 0$$

and if ,

$$(A1) \quad F(0, 0, t) = 0 \quad \text{for } x, v = 0 ,$$

$$(A2) \quad G(0, 0, t) = 0 \quad \text{for } x, v = 0 ,$$

$$(A3) \quad G(x, v, t) > 0 \quad \text{for } x, v \neq 0$$

then the optimally regulated system $\dot{y} = F(y(t), u_*(y, t), t)$, is asymptotically stable about the origin .

PROOF .

It suffices to verify that J_* satisfies the properties (i)-(iii). Clearly, under the given assumptions we can write



$$\frac{\partial}{\partial t} J_*(x, t) + (F(x(t), u_*(x, t), t), [J_*(x, t)]_x) + G(x(t), u_*(x, t), t) = 0 \quad (2.39)$$

where $x(t), t > t_0$ is any solution of the differential equation

$$\dot{x} = F(x(t), u_*(x, t), t) \quad (2.40)$$

For non-zero initial state, equation (2.40) has a non-trivial solution. Thus, due to assumptions (A1) and (A2), the function $J_*(x, t) > 0$ for $x \neq 0$. Further, for $x=0$ and $u_*(0, t)=0$ we have $J_*(0, t)=0$. Again, for any non-trivial solution of (2.40), the function $G(x, u_*, t) > 0$ and hence the property (iii) follows from (2.39). Finally, since $u_*(0, t)=0$ (as indicated above) it follows from assumption (A1) that the origin (in R^n) is a rest point for the system (2.39). This completes the proof of the Lemma. \square

In the next two chapters, the application of Theorem 2.1 is considered for study of the optimal regulation of a satellite angular momentum dynamics using a combination of reaction jets and flywheels. Further, the major problems encountered in the application of this theory are also discussed.

2.6 SUMMARY

In this chapter, the theory of optimal control developed in [1,2]-has been presented. The proof of the existence of a unique optimal feedback control, in the case of free end problem, was given (see Theorem 2.1). The methods which can be used in order to compute the linear as well as non-linear optimal feedback controls were presented. Finally, with the aid of Liapunov theory, it was shown that the optimally regulated system (2.7) is necessary asymptotically stable about the origin.

Chapter III

REGULATION OF SATELLITE ANGULAR MOMENTA USING JETS AND FLYWHEELS

3.1 INTRODUCTION

In this chapter, the theory of optimal control, previously presented, is used for study of an optimal regulation problem of satellite angular momentum dynamics using a combination of reaction jets and flywheels. A suitable feedback controller which minimizes the cost of fuel and energy is developed. This control model is designed in such a way that system regulation, under large perturbation, to a proper bounded subset in E^n is achieved by using reaction jets. Thereafter, flywheels are activated to bring the system to the rest (desired) state. The domain and its size over which reaction jets are active and the corresponding fuel cost are discussed. Further, the effect of linear as well as non-linear second order feedback regulators on system behaviour is indicated. The range (in the state space E^n) over which the flywheels are capable of regulating the system is studied. Finally, the problems encountered in computing the optimal control are briefly discussed.

3.2 SYSTEM MODEL AND FORMULATION OF REGULATOR PROBLEM

The Satellite angular momentum dynamics, using both reaction jets and flywheels, can be described as follows [4]:

$$\begin{aligned}
 I_x \dot{p} + (I_z - I_y) (q - w_0) r + C_x \dot{\Omega}_x - C_y \Omega_y r + C_z \Omega_z q &= T_x \\
 I_y \dot{q} + (I_x - I_z) p r + C_x \Omega_x r + C_y \dot{\Omega}_y - C_z \Omega_z p &= T_y \\
 I_z \dot{r} + (I_y - I_x) (q - w_0) p - C_x \Omega_x q + C_y \Omega_y p + C_z \dot{\Omega}_z &= T_z
 \end{aligned} \tag{3.1}$$

where p, q, r represent the angular momenta of satellite body (space craft). The quantities $\Omega_x, \Omega_y, \Omega_z$ are the angular velocities of the flywheels and T_x, T_y, T_z are the (applied) torques due to reaction jets. The rest of the symbols are the parameters of the system (Satellite and flywheel moments of inertia).

For the purpose of regulation we consider the torques (T_x, T_y, T_z) and the flywheel accelerations ($\dot{\Omega}_x, \dot{\Omega}_y, \dot{\Omega}_z$) as the control variables, and we define them by the vector

$$v = (v_1, v_2, \dots, v_6)' = (T_x, T_y, T_z, \dot{\Omega}_x, \dot{\Omega}_y, \dot{\Omega}_z)' \tag{3.2}$$

where Ω_x, Ω_y and Ω_z are the flywheel angular velocities in the x, y and z directions, respectively.

Using (3.1) and (3.2), the overall system model is given by

$$\begin{aligned}
 I_x \dot{p} + (I_z - I_y)(q - w_0)r + C_x v_4 - C_y \Omega_y r + C_z \Omega_z q &= v_1 \\
 I_y \dot{q} + (I_x - I_z)pr + C_x \Omega_x r + C_y v_5 - C_z \Omega_z p &= v_2 \\
 I_z \dot{r} + (I_y - I_x)(q - w_0)p - C_x \Omega_x q + C_y \Omega_y p + C_z v_6 &= v_3
 \end{aligned}
 \tag{3.3}$$

$$\begin{aligned}
 \dot{\Omega}_x &= v_4 \\
 \dot{\Omega}_y &= v_5 \\
 \dot{\Omega}_z &= v_6
 \end{aligned}$$

The objective is to design a regulator (or a feedback control law) that brings the system to a rest (desired) state following a sudden perturbation. Further, the control system should be such that it achieves the above objective with minimum cost of fuel and energy. A suitable cost function that satisfies the above requirements is given by

$$\begin{aligned}
 J(v) = \int_0^T [&\lambda_1 (p^2 + q^2 + r^2) + \lambda_2 (\Omega_x^2 + \Omega_y^2 + \Omega_z^2) \\
 &+ \lambda_3 (v_1^2 + v_2^2 + v_3^2) + \lambda_4 (v_4^2 + v_5^2 + v_6^2)] dt
 \end{aligned}
 \tag{3.4}$$

for $\lambda_1, \lambda_2, \lambda_3$ and $\lambda_4 > 0$ and $t \in [t_0, T]$. The first two terms in the above equation represent the kinetic energy of the system. The last two terms represent the cost of the feedback controls which are used to regulate the system. Now our problem is to find an optimal feedback control law which minimizes the integral (3.4).

For convenience of further development we write equation (3.3) and (3.4), in matrix notation, as

$$\dot{x} = Ax + Bv(x,t) + f(x,t) \quad (3.5)$$

$$J(v) = \int_0^T [x'Qx + v'Ev] dt$$

where $x = (F, g, r, \Omega_x, \Omega_y, \Omega_z)'$ and $v = (v_1, v_2, \dots, v_6)'$. The matrices A, B, f, Q and E are given by

$$A = \begin{bmatrix} 0 & 0 & a_1 & c & 0 & 0 \\ 0 & 0 & 0 & c & 0 & c \\ a_2 & 0 & 0 & c & 0 & c \\ 0 & 0 & 0 & c & c & c \\ 0 & 0 & 0 & c & 0 & 0 \\ 0 & 0 & 0 & c & 0 & c \end{bmatrix}$$

$$E = \begin{bmatrix} b_{11} & c & 0 & e_{14} & 0 & 0 \\ 0 & b_{22} & 0 & c & b_{24} & 0 \\ 0 & 0 & b_{33} & c & 0 & e_{36} \\ 0 & 0 & 0 & e_{44} & 0 & c \\ 0 & 0 & 0 & c & b_{55} & 0 \\ 0 & 0 & 0 & c & 0 & e_{66} \end{bmatrix}$$

$$f = \begin{bmatrix} c_1 p r + c_4 \Omega_y r + c_5 \Omega_z q \\ c_2 p r + c_6 \Omega_x r + c_7 \Omega_z p \\ c_3 p q + c_8 \Omega_x q + c_9 \Omega_y p \\ 0 \\ c \\ 0 \end{bmatrix}$$

$$Q = \begin{bmatrix} \lambda_1 & 0 & 0 & 0 & 0 & c \\ 0 & \lambda_1 & c & c & 0 & 0 \\ 0 & 0 & \lambda_1 & c & 0 & 0 \\ 0 & 0 & 0 & \lambda_2 & c & c \\ 0 & 0 & 0 & 0 & \lambda_2 & c \\ 0 & 0 & 0 & c & 0 & \lambda_2 \end{bmatrix}$$

$$R = \begin{bmatrix} \lambda_3 & 0 & 0 & c & c & c \\ 0 & \lambda_3 & c & c & 0 & 0 \\ 0 & 0 & \lambda_3 & c & 0 & 0 \\ 0 & 0 & 0 & \lambda_4 & 0 & 0 \\ 0 & 0 & 0 & 0 & \lambda_4 & c \\ 0 & 0 & 0 & 0 & 0 & \lambda_4 \end{bmatrix}$$

where,

$$a_1 = \frac{(I_z - I_y)}{I_x} w_0, \quad a_2 = \frac{(I_y - I_x)}{I_z} w_0, \quad c_1 = \frac{(I_z - I_y)}{I_x}, \quad c_2 = \frac{(I_x - I_z)}{I_y},$$

$$c_3 = \frac{(I_y - I_x)}{I_z}, \quad c_4 = \frac{c_y}{I_x}, \quad c_5 = -\frac{c_z}{I_x}, \quad c_6 = -\frac{c_x}{I_y}, \quad c_7 = \frac{c_z}{I_y}, \quad c_8 = \frac{c_x}{I_x},$$

$$c_9 = -\frac{C_y}{I_z}, b_{11} = \frac{1}{I_x}, b_{14} = -\frac{C_x}{I_x}, b_{22} = \frac{1}{I_y}, b_{25} = -\frac{C_y}{I_y}, b_{33} = \frac{1}{I_z},$$

$$b_{36} = -\frac{C_z}{I_z} \text{ and } b_{44} = b_{55} = b_{66} = 1.$$

In the following section, an algorithm for computing the linear and nonlinear feedback controls is provided. Then with the aid of this algorithm, an optimal feedback control system model, which minimizes the cost of fuel and energy will be developed. The basic idea of this control model will be discussed in detail in section 3.4.

3.3 STRUCTURE OF OPTIMAL FEEDBACK REGULATOR

As indicated earlier in chapter (II), the feedback control which minimizes the cost functional (3.5), can be expressed in power series as

$$u_*(x,t) = u_*^{(1)}(x,t) + u_*^{(2)}(x,t) + \dots \tag{3.6}$$

where the first term in the series is given by

$$u_*^{(1)}(x,t) = -R^{-1} B^T K_*(t) x \tag{3.7}$$

The matrix function $K_*(t)$ is the solution of the Riccati equation (2.10) (see Appendix A). Once the value of K_* is found, the linear optimal feedback control (for the linear system) can be obtained using (3.7). The non-linear second order term in (3.6) is calculated using the following algorithm :

STEP (i).

(2)

Determine J_* (x,t) using the equation

$$J_*^{(2)}(x,t) = x'K_*(t)x.$$

STEP (ii).

(3)

Set $m=3$ in (2.37) and define $J_*^{(3)}(x,t) = \phi(\alpha_1, \dots, \alpha_k, x, t)$ where ϕ is a homogenous polynomial in the variables x , $1 \leq i \leq n$, of degree exactly three (or in general m) and α 's are coefficients (in general functions of time). This yields a system of differential equations for the α 's. These equations can be written as

$$[A_* x]' [J_*^{(3)}(x,t)]_x + [J_*^{(3)}(x,t)]_t = -[f(x, u_*, t)]' [J_*^{(2)}(x,t)]_x.$$

STEP (iii).

Solve the differential equations (obtained in (ii)) for $(\alpha_1(t), \dots, \alpha_k(t))'$ with the final conditions $(\alpha_1(T), \dots, \alpha_k(T))' = 0$.

STEP (iv).

Set $k=2$ in equation (2.38) and obtain the non-linear second order control $u_*^{(2)}(x,t)$.

Following the same procedure, the higher order terms of u can be easily found. For system (3.5), we have computed the optimal feedback control up to second order. Once $u_*^{(1)}$ and $u_*^{(2)}$ are found, linear and non-linear second order feedback controls can be expressed, respectively as

$$\begin{aligned}
 \dot{w} &= u_{*}^{(1)}(x,t) = -E^{-1} B^* K_{*}^{(1)}(t) x, \\
 \dot{w} &= u_{*}^{(1)}(x,t) + u_{*}^{(2)}(x,t) = -E^{-1} B^* (K_{*}^{(1)}(t) x + \\
 &\quad 1/2 [J_{*}^{(3)}(x,t)]_x
 \end{aligned} \tag{3.8}$$

where the term $[J_{*}^{(3)}(x,t)]_x$ is the partial derivative of $J_{*}^{(3)}(x,t)$ with respect to the state x .

In the following section, system (3.5) and the feedback control law, given in (3.8), are used to develop the overall system model.

3.4 SYSTEM CONTROL MODEL

As indicated earlier, the system control model presented here is developed in such a way that under large perturbations system regulation, to an open bounded subset in R , is achieved by the reaction jets. Then the reaction jets are shut off and flywheels are activated to bring the system to a rest (desired) state. During this period, flywheels can be either under non-saturating or saturating modes of operation.

In the non-saturating mode, the flywheels are stationary at the initial time. They are then accelerated in a prescribed fashion to correct the disturbance such that their kinetic energy (angular velocities), when the disturbance is removed, are equal to zero. Obviously this type of control can not correct any initial disturbance in the angular body rates

because the net change in angular momentum for the overall system, in this case, is zero. Due to this disadvantage, we have considered the flywheels to be under the saturating mode to be capable of minimizing the satellite kinetic energy [5].

To satisfy the requirement as stated in the introduction of this section, we have defined the feedback control law as

$$v(x,t) = E(x,t) u(x,t) \quad (3.9)$$

where the control variable $u = W$ ($i = 1$ or 2) (see equation (3.8)). The matrix function $E(x,t)$ in (3.9) is a decision maker which provides the system with the appropriate control (either jet or flywheel). This matrix is given by

$$E(x,t) = \begin{bmatrix} e_1 & 0 & 0 & c & c & c \\ 0 & e_2 & 0 & c & c & c \\ 0 & 0 & e_3 & 0 & 0 & c \\ 0 & c & 0 & e_4 & 0 & c \\ 0 & 0 & 0 & c & e_5 & c \\ 0 & c & 0 & c & 0 & e_6 \end{bmatrix} \quad (3.10)$$

The elements e_i ($i=1,2,\dots,6$) are defined as

$$e_i = \begin{cases} 1/2[1 + \text{sign}(\|x\| - r)] & \text{for } x \notin S_r, 1 \leq i \leq 3 \\ 1/2[1 + \text{sign}(r - \|x\|)] & \text{for } x \in S_r, 4 \leq i \leq 6 \end{cases} \quad (3.11)$$

where

$$S_r = \{ x \in \mathbb{R}^6 : \|x\| < r, \text{ for some } r > 0 \}$$

and

$$\|x\| = \sqrt{\sum_{j=1}^6 x_j^2}$$

The equations (3.9), (3.10) and (3.11) can be interpreted in the following sense; under large perturbations ($\|x\| \gg r$), $e_i = 1$ for $1 \leq i \leq 3$ and 0 for $4 \leq i \leq 6$. For small perturbations ($\|x\| < r$), $e_i = 0$ for $1 \leq i \leq 3$ and 1 for $4 \leq i \leq 6$. Using this matrix in (3.9), we have

$$v(x, t) = \begin{cases} (v_1, v_2, v_3, 0, 0, 0)' & \text{for } \|x\| \gg r \\ (0, 0, 0, v_4, v_5, v_6)' & \text{for } \|x\| < r \end{cases}$$

Substituting (3.9) into system (3.5), the overall system model is given by

$$\dot{x} = Ax + BE(x,t)u(x,t) + f(x,t)$$

(3.12)

$$J(Eu) = \int_0^T [x'Qx + (Eu)'R(Eu)] dt$$

For convenience of representation of the complete system model, using a combination of reaction jets and flywheels, we have used equations (3.8) and (3.12) to develop the system block diagram shown in fig.3.3. Throughout our study we have used such model to justify the effectiveness of the different regulators (see figures 3.2 - 3.11).

3.5 EFFECTIVENESS OF FEEDBACK REGULATORS

In this section, the control model developed in the previous section has been used to study the effect of different regulators (linear or non-linear) on the system behaviour. Since the objective of the regulator is to steer the system state to the origin (after a sudden perturbation), we have considered the following measures to evaluate the merits of the proposed scheme (fig.3.1):

a- Distance of the (space craft) dynamic state $(p(t), q(t), r(t))'$ from the origin and its variation with time

b- Distance of the flywheel state $(\Omega_x(t), \Omega_y(t), \Omega_z(t))'$ from the origin and its variation with time

c- The domain and its size over which reaction jets are active and the corresponding fuel cost. (note that the size of the domain depends on the initial perturbation and the prescribed radius of the ball S_r on the boundary of which the reaction jets are shut off and the flywheels activated).

d- The quality of regulation depending on the radius of the ball S_r (in which the flywheels are active).

SYSTEM DYNAMICS

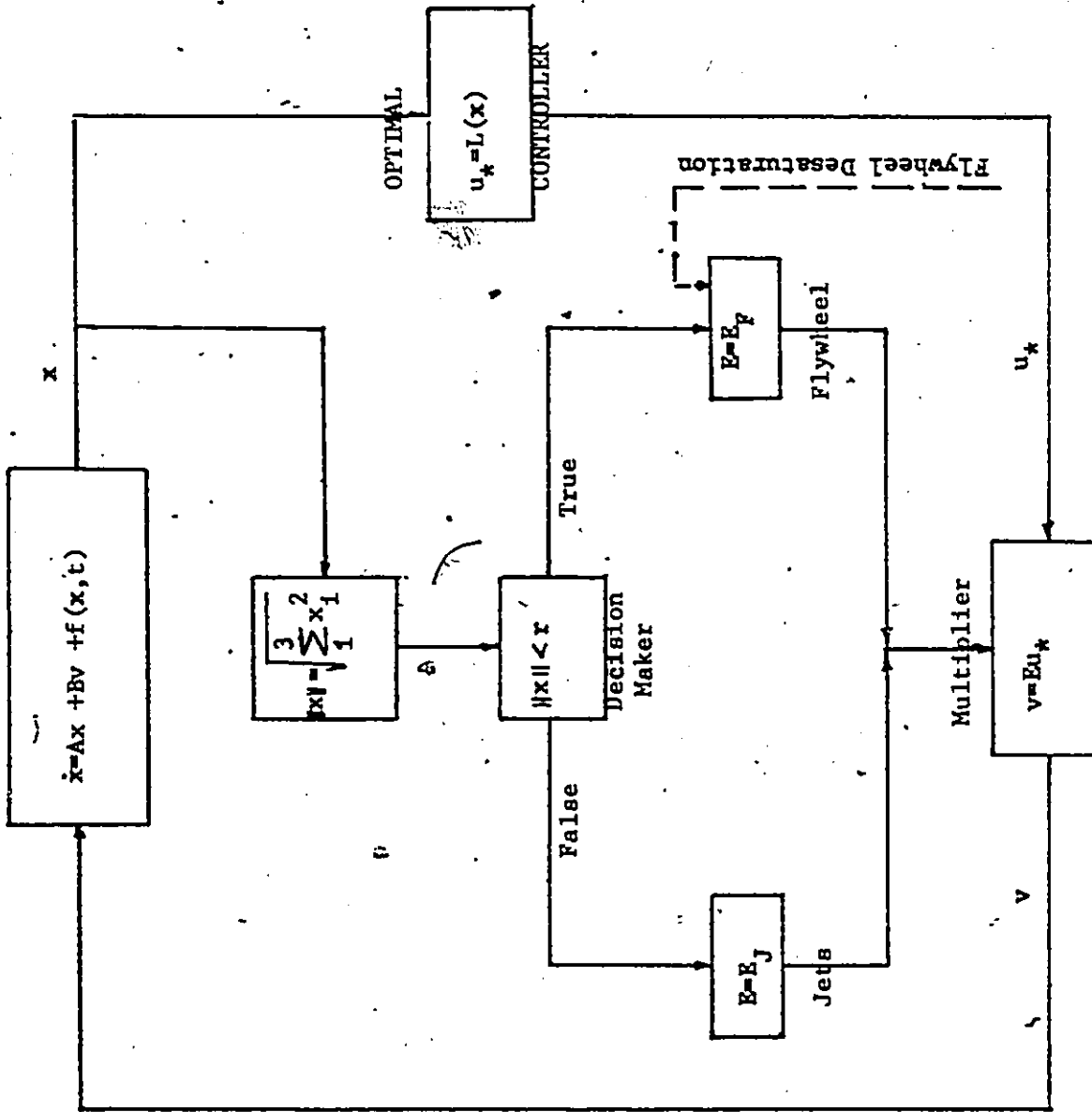

$$E_F = \begin{bmatrix} 0 & 0 & 0 & 0 & 0 & 0 & 0 & 0 \\ 0 & 0 & 0 & 0 & 0 & 0 & 0 & 0 \\ 0 & 0 & 0 & 0 & 0 & 0 & 0 & 0 \\ 0 & 0 & 0 & 0 & 1 & 0 & 0 & 0 \\ 0 & 0 & 0 & 0 & 0 & 1 & 0 & 0 \\ 0 & 0 & 0 & 0 & 0 & 0 & 1 & 0 \\ 0 & 0 & 0 & 0 & 0 & 0 & 0 & 1 \end{bmatrix}$$

$$E_J = \begin{bmatrix} 1 & 0 & 0 & 0 & 0 & 0 & 0 & 0 \\ 0 & 1 & 0 & 0 & 0 & 0 & 0 & 0 \\ 0 & 0 & 1 & 0 & 0 & 0 & 0 & 0 \\ 0 & 0 & 0 & 0 & 0 & 0 & 0 & 0 \\ 0 & 0 & 0 & 0 & 0 & 0 & 0 & 0 \\ 0 & 0 & 0 & 0 & 0 & 0 & 0 & 0 \\ 0 & 0 & 0 & 0 & 0 & 0 & 0 & 0 \\ 0 & 0 & 0 & 0 & 0 & 0 & 0 & 0 \end{bmatrix}$$

$$L(x) = W^{(i)} \begin{cases} i = 1 & \text{Linear} \\ i = 2 & \text{2nd-order} \end{cases}$$

Fig. 3.1 Satellite optimal control system model using a combination of jets and flywheels.

e- The range (in the state space R^n) over which the non-linear second order regulator, using flywheel alone, is capable of regulating the system towards the origin after a sudden perturbation.

For the purpose of numerical simulation, the following parameters have been used

$$\begin{array}{ll}
 I_x = 645 & \text{slug-ft}^2 \\
 I_y = 100 & \text{slug-ft}^2 \\
 I_z = 669 & \text{slug-ft}^2 \\
 C_x = 1.0 & \text{slug-ft}^2 \\
 C_y = 0.02 & \text{slug-ft}^2 \\
 C_z = 1.2 & \text{slug-ft}^2 \\
 \lambda_1 = 10.0 & \\
 \lambda_2 = 10 & \\
 \lambda_3 = 1.0 & \\
 \lambda_4 = 0.01 & \\
 \omega_0 = 7.29 \times 10^{-5} & \text{rad/sec.}
 \end{array}$$

Using these parameters, the differential equation

$$\dot{x} = A x + B v(x,t) + f(x,t)$$

representing the optimal regulator of fig.3.1, was simulated on the university of Ottawa's Digital Computer AMDAHL 470/V613. For $v = E W^{(1)}$ (see fig.3.1), let $(p_1(t), q_1(t), r_1(t))'$ denote the state of the space craft and $(\Omega_{x_1}(t), \Omega_{y_1}(t), \Omega_{z_1}(t))'$ denote the state of the flywheel. Let the corresponding distance (to the origin) be denoted by $d_1(t)$ and $\bar{d}_1(t)$, respectively. Similarly, for $v = E W^{(2)}$, we have the corresponding distances $d_2(t)$ and $\bar{d}_2(t)$, respectively. The numerical results obtained, corresponding to linear as well non-linear second order feedback regulators, are shown in figures 3.2-3.13. For convenient comparison of the results, the following notations are used in figures 3.2-3.11

aa = Reaction jets alone, linear feedback regulator,

bb = Reaction jets alone, non-linear feedback regulator,

aa₁ = Reaction jets and flywheels, linear feedback regulator, r = 0.2,

bb₁ = Reaction jets and flywheels, non-linear feedback regulator, r = 0.3.

Similarly, for r = 0.7 we have the results [aa₂, bb₂].

From these results one observes the following.

(i) Under the given initial perturbation ($d_1(0) = 3.46$), system regulation using non-linear second order regulator ($w^{(2)}$) is comparatively better than that obtained by linear regulator ($w^{(1)}$) (see curves aa, bb; aa₁, bb₁; aa₂, bb₂ in figures 3.8 and 3.9).

(ii) As the region over which reaction jets are operated shrinks (i.e., r increases), the time taken by the system to attain the rest state increases (for example see curves aa, aa in fig. 3.8). However, the corresponding fuel cost required to run the jets is reduced. On the other hand, expanding the operating region of the reaction jets (i.e., decreasing r), yields a better regulation but the corresponding fuel cost is comparatively high (compare curves aa, bb; aa₂, bb₂ in figs. 3.8, 3.9). Therefore, a reasonable value of r can be chosen on the basis of relative importance of accuracy of regulation and fuel expenses.

$d(0)=3.46$ (Linear control is used)

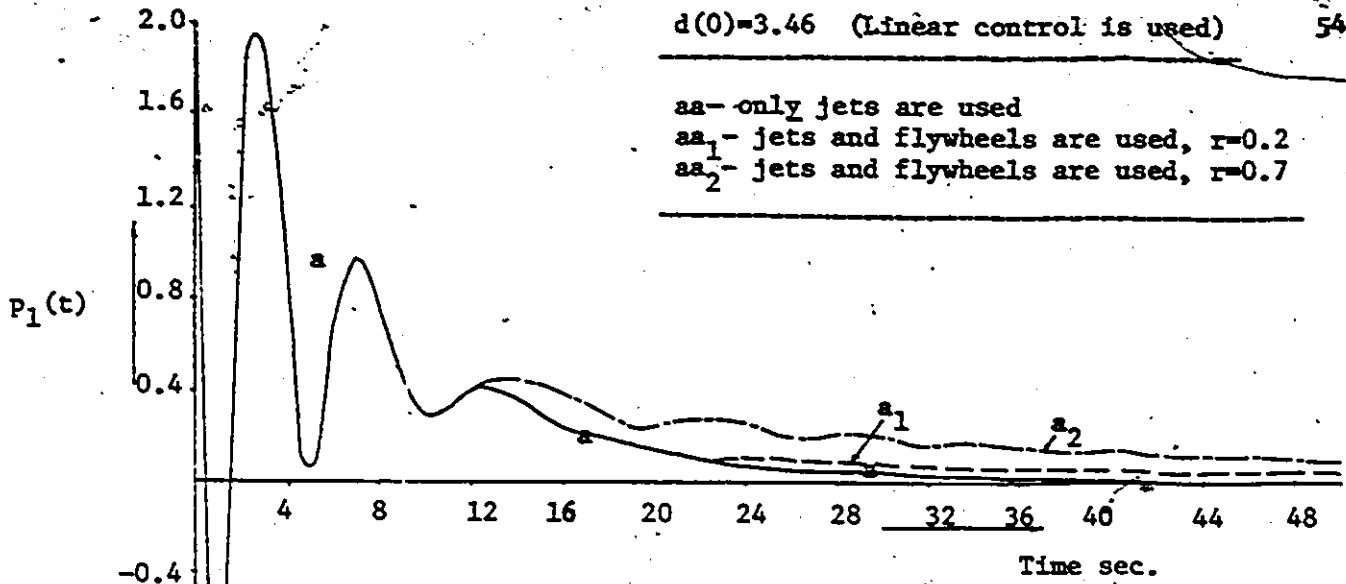

aa- only jets are used
aa₁- jets and flywheels are used, $r=0.2$
aa₂- jets and flywheels are used, $r=0.7$

Fig. 3.2 Satellite angular momentum in the x-direction.

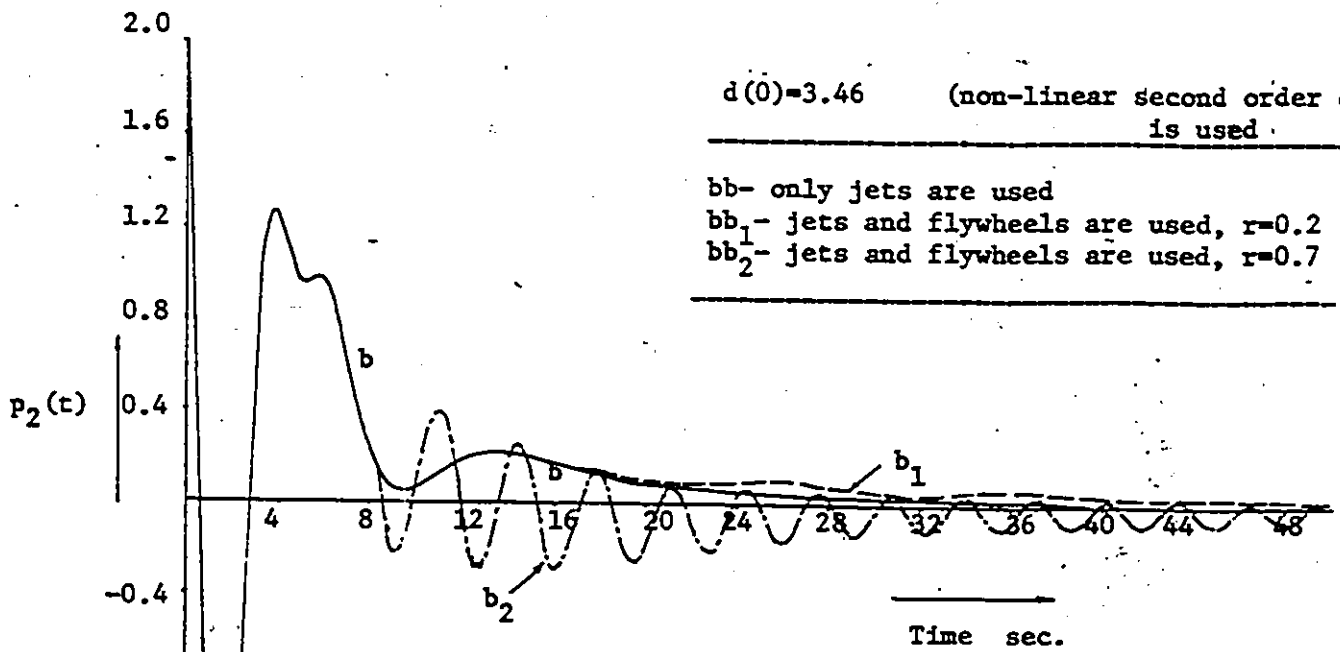

$d(0)=3.46$ (non-linear second order control is used)

bb- only jets are used
bb₁- jets and flywheels are used, $r=0.2$
bb₂- jets and flywheels are used, $r=0.7$

Fig. 3.3 Satellite angular momentum in the x-direction.

$d(0)=3.46$

- aa- jets are only used
- aa₁- jets and flywheels are used, r=0.2
- aa₂- jets and flywheels are used, r=0.7

Linear ($w^{(1)}$) control is used.

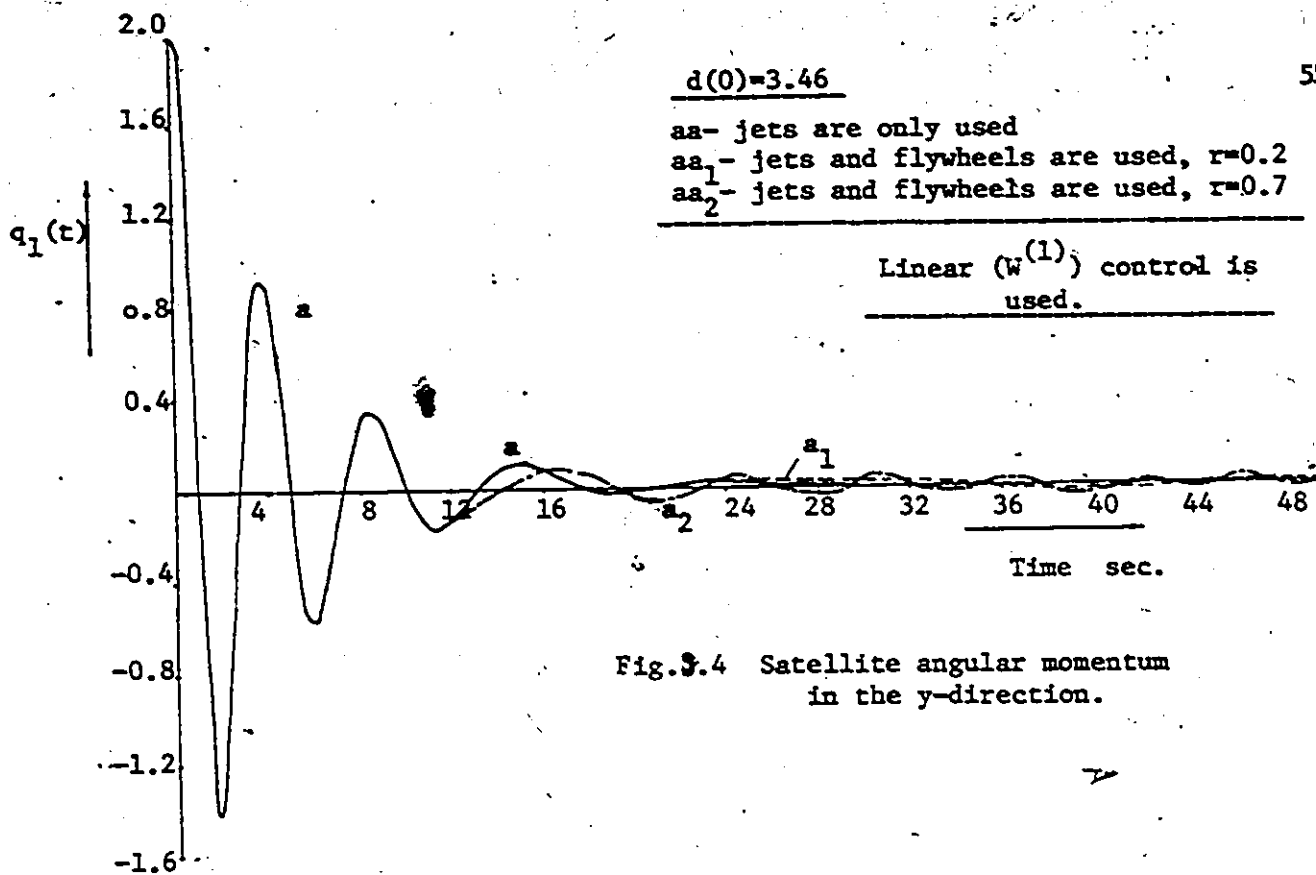

Fig. 3.4 Satellite angular momentum in the y-direction.

$d(0)=3.46$ (non-linear 2nd-order control) is used

- bb- only jets are used
- bb₁- jets and flywheels are used, r=0.2
- bb₂- jets and flywheels are used, r=0.7

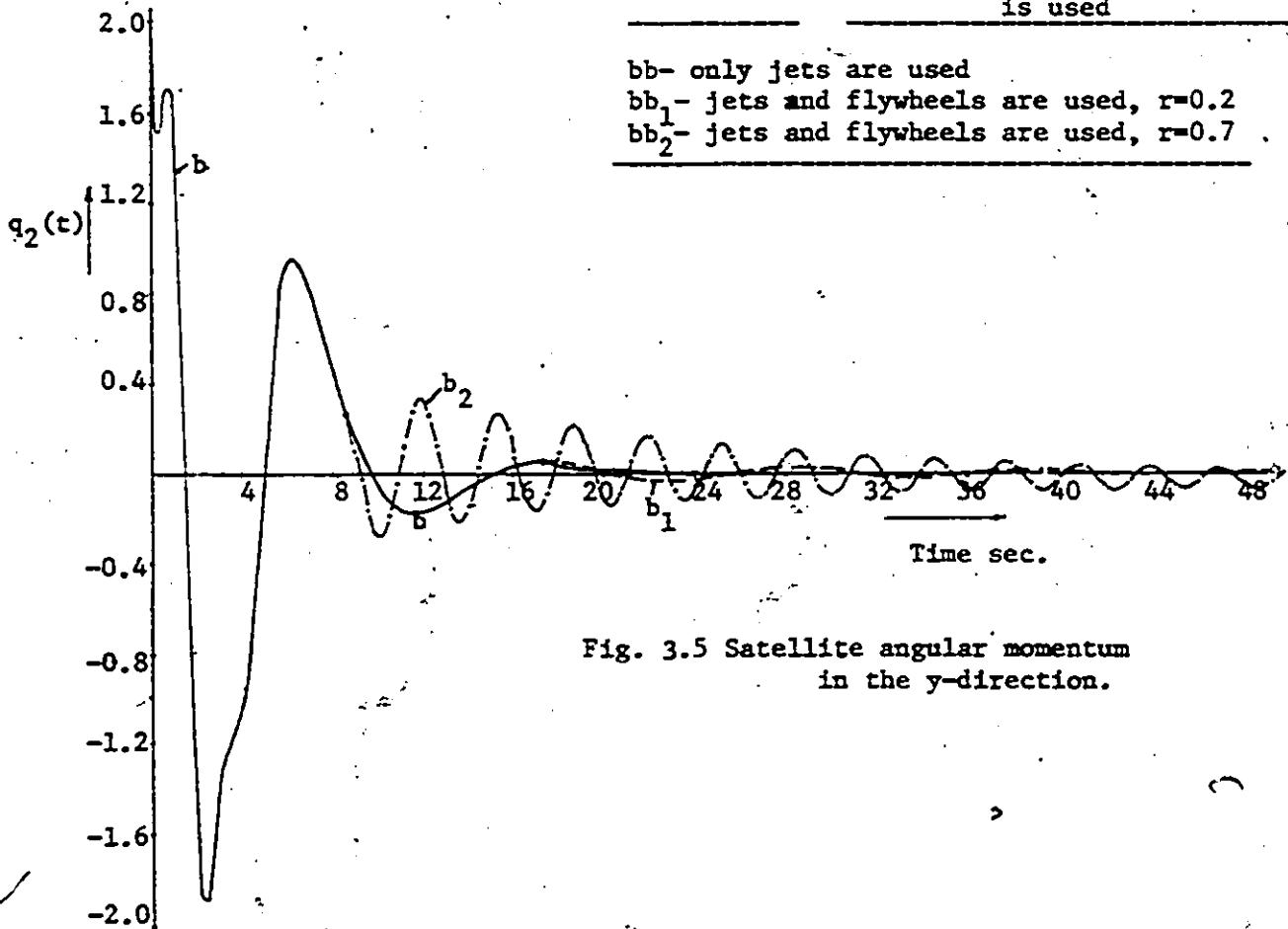
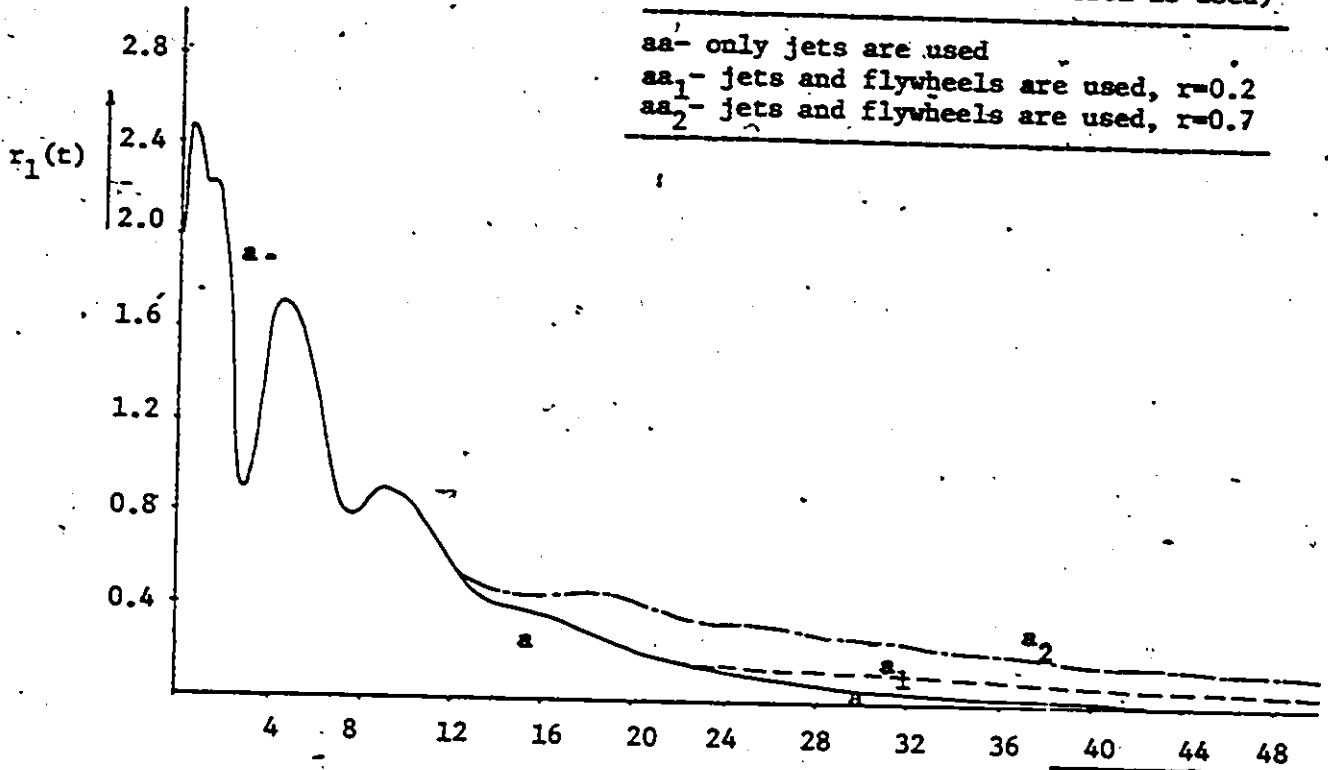

Fig. 3.5 Satellite angular momentum in the y-direction.

$d(0)=3.46$ (Linear control is used)



aa- only jets are used
aa₁- jets and flywheels are used, $r=0.2$
aa₂- jets and flywheels are used, $r=0.7$

Fig.3.6 Satellite angular momentum in the x-direction.

$d(0)=3.46$ (non-linear second order control is used)

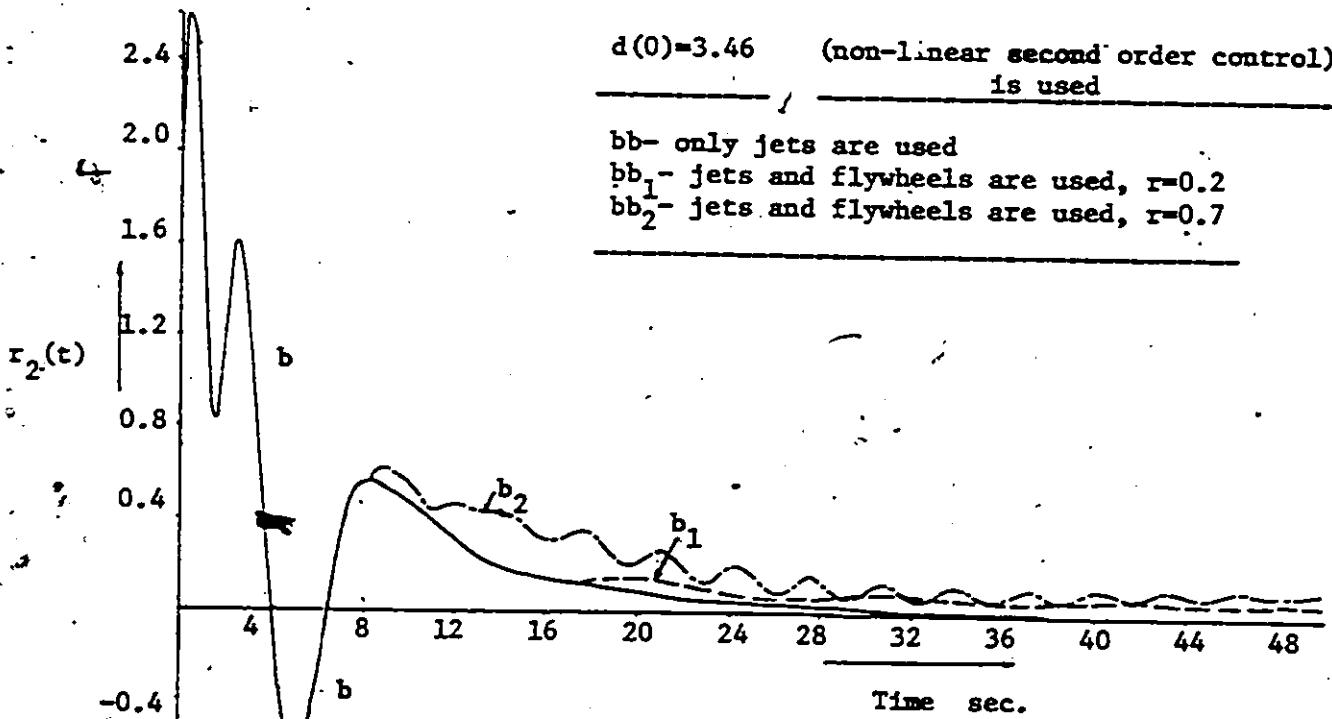

bb- only jets are used
bb₁- jets and flywheels are used, $r=0.2$
bb₂- jets and flywheels are used, $r=0.7$

Fig. 3.7 Satellite angular momentum in the z-direction.

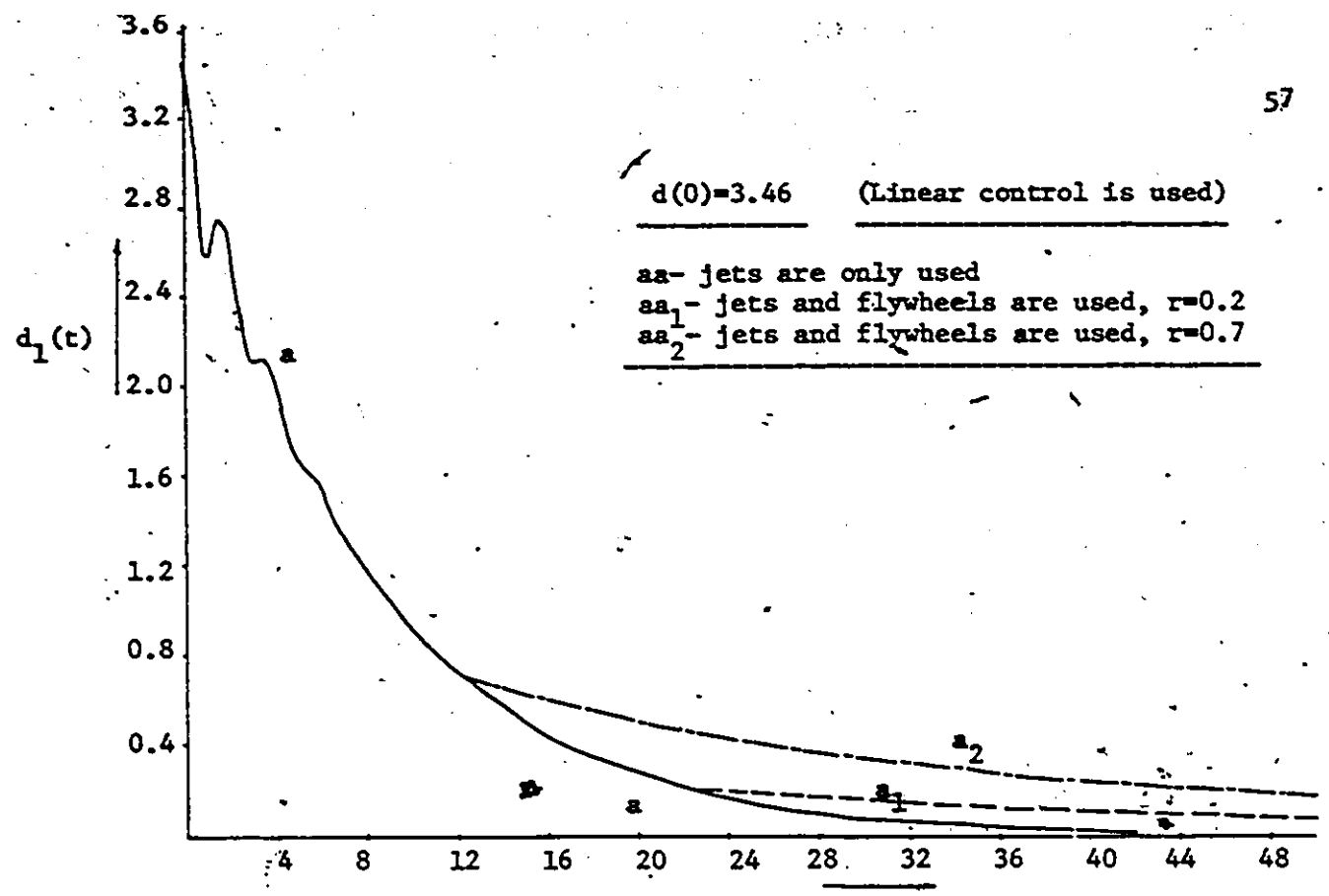

Fig. 3.8 Distance from the state to the origin.

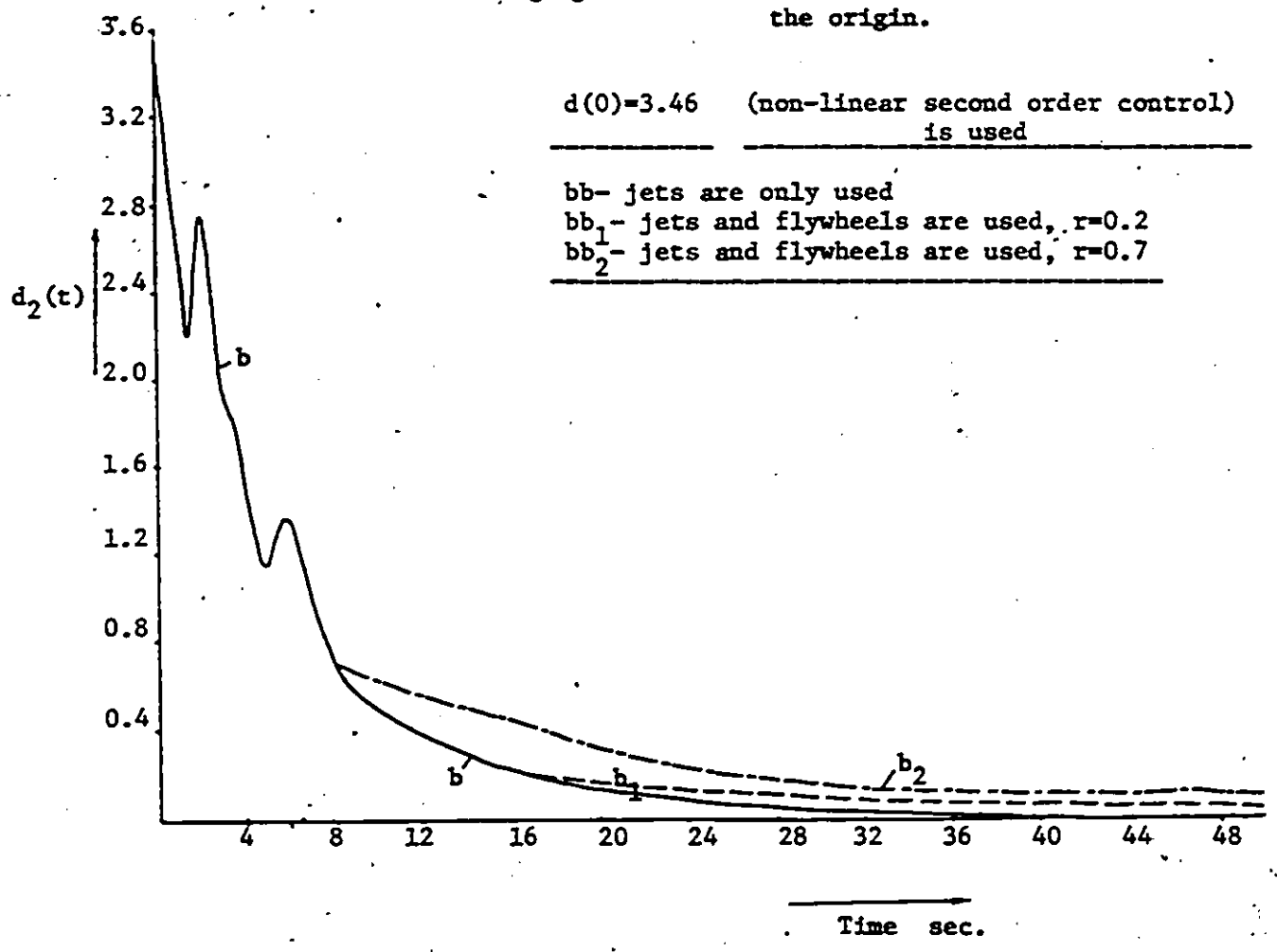

Fig. 3.9 Distance from the state to the origin.

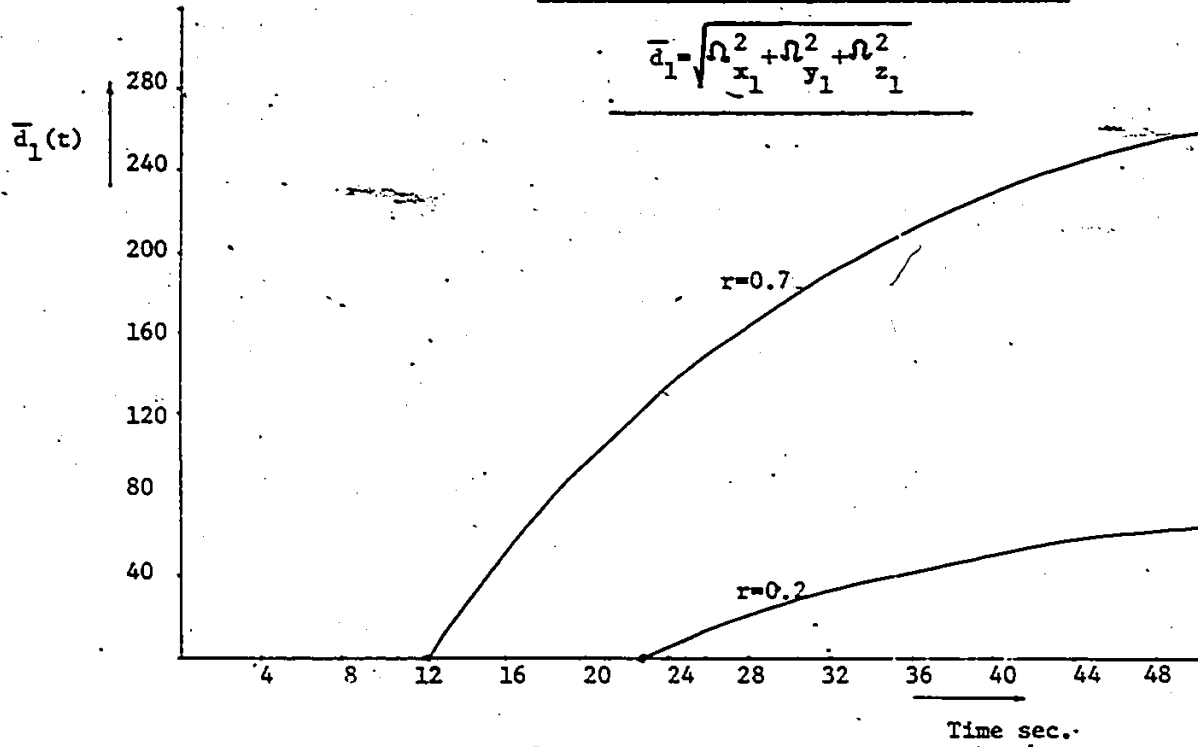

Fig. 3.10 Distance From Flywheel State to the origin

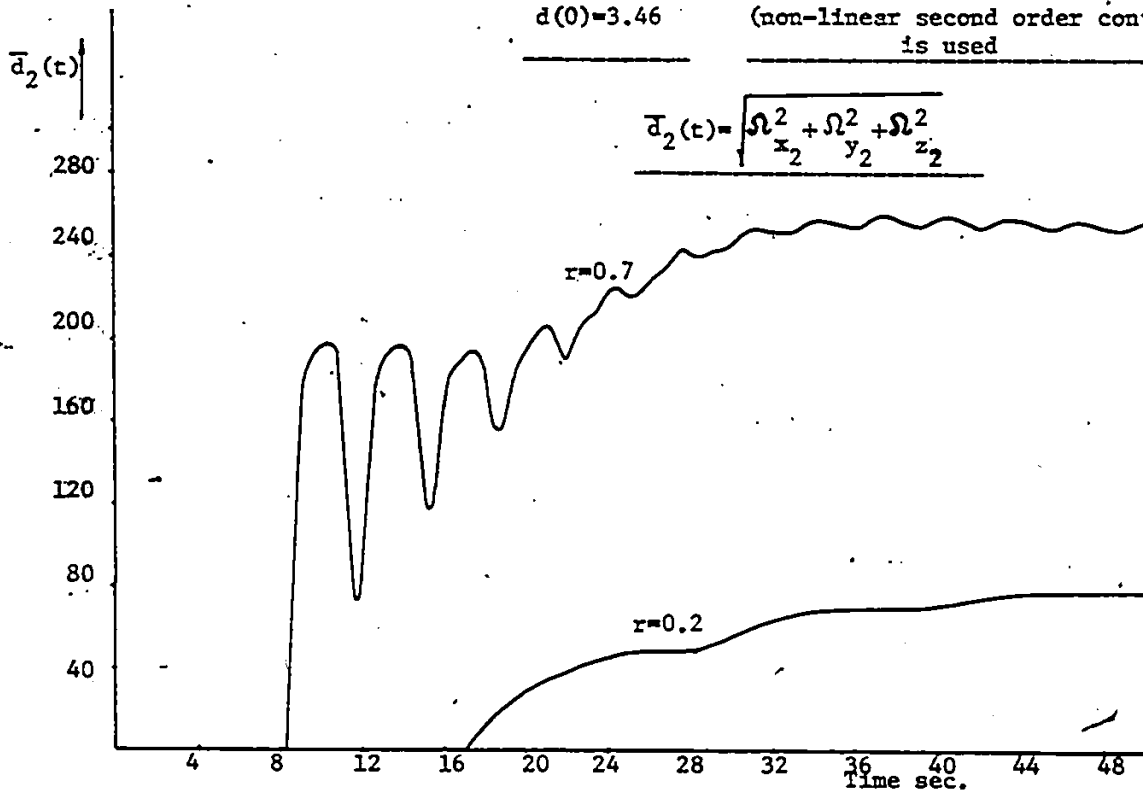

Fig. 3.11 Distance From Flywheel State to the origin

(iii) For large perturbation ($r > 0.7$), it was found that the non-linear second order feedback regulator $(W^{(2)})$, using flywheel alone, fails to regulate the system (becomes unstable). On the other hand, linear regulator $(W^{(1)})$, when it is applied to the non-linear system (3.5), is globally stable but the time taken by the system to attain the rest state is quite large. However, the behaviour of the non-linear feedback regulator can be improved by introducing more non-linear terms in series (3.6). The only difficulty in doing that is the large number of differential equations one has to solve in order to compute the coefficients α 's and consequently the corresponding u^* (see steps (ii), (iii) in section 3.3). This problem will be discussed with more details in the next chapter.

(iv) The distance $\bar{d}_1(t)$ of flywheel angular velocities $(\Omega_x, \Omega_y, \Omega_z)$ from the origin attains a constant value after disturbance has been removed (see figs. 3.10, 3.11). Indeed such result was expected, since the weighting factor λ_2 in (3.4) has been chosen quite small to serve as a preventive mechanism against having a run away situation in the angular velocities. In other words, the use of a saturating flywheel has a major advantage of being capable of correcting the initial disturbance in the satellite body angular momentum [5]. However, for practical convenience, the flywheel angular velocities (or kinetic energy) should be reduced to zero after the disturbance has been removed. A means of doing

this is to provide an opposing torque (impact) to desaturate ([4], pp. 406,408) the flywheel (fig.3.1).

3.6 . SUMMARY .

In this chapter, the application of Theorem 2.1 has been considered for the study of Satellite optimal regulation. A suitable control model, which minimizes the cost of fuel and energy, has been developed using a combination of reaction jets (for larger perturbations) and flywheels (for mild perturbations) (see fig.3.1). Using such a model, we have observed that; under some initial perturbations better regulation can be achieved by applying non-linear second order control. As the region, over which the reaction jets operate, is shrunked, the corresponding cost of fuel reduces but larger time is required for the system to attain the rest (desired) state. However, using the control model provided here, one can choose a suitable region of operation of the reaction jets (by changing τ) such that the system can attain the rest state fairly fast with reasonable fuel cost.

Chapter IV

REGULATION OF SATELLITE ANGULAR MOMENTA USING REACTION JETS ONLY

INTRODUCTION

In the previous chapter, the optimal regulation of satellite dynamics using a combination of reaction jets (for large perturbations) and flywheels (for mild perturbations) has been investigated. In this chapter, the optimal regulation properties of a satellite using reaction jets with flywheels having fixed angular velocities, is considered. The effects of linear, non-linear second order and third order controls on the system behaviour are compared. The cost corresponding to each regulator, under different initial perturbations, are obtained. The range in the state space R^n over which these regulators are capable of regulating the system is indicated. Finally, the problem encountered in the application of the previous control theory is discussed with more details.

4.1 SYSTEM MODEL AND FORMULATION OF THE REGULATOR PROBLEM

The Satellite angular momentum dynamics, using reaction jets with flywheel having fixed angular velocities, can be described as [4] :

$$\begin{aligned}
 I_x \dot{p} + (I_z - I_y) (q-w) r - C_y \Omega_y r + C_z \Omega_z q &= T_x \\
 I_y \dot{q} + (I_x - I_z) pr + C_x \Omega_x r - C_z \Omega_z p &= T_y \\
 I_z \dot{r} + (I_y - I_x) (q-w) p - C_x \Omega_x q + C_y \Omega_y p &= T_z
 \end{aligned} \tag{4.1}$$

where $(p, q, r)'$ represent the angular momentum of Satellite body, $(\Omega_x, \Omega_y, \Omega_z)$ are the flywheel angular velocities (which are fixed quantities) and (T_x, T_y, T_z) are the (applied) torques due to reaction jets.

Here we have considered the torques (T_x, T_y, T_z) as the control variables, which can be defined by the vector

$$u = (u_1, u_2, u_3)' = (T_x, T_y, T_z)' \tag{4.2}$$

Using (4.1) and (4.2), system equation can be written as

$$\begin{aligned}
 \dot{p} &= a_1 q + a_2 r + a_3 qr + a_4 u_1 \\
 \dot{q} &= b_1 p + b_2 r + b_3 pr + b_4 u_2 \\
 \dot{r} &= c_1 p + c_2 q + c_3 pq + c_4 u_3
 \end{aligned} \tag{4.3}$$

where

$$\begin{aligned}
 a_1 &= -\frac{C_z \Omega_z}{I_x}, \quad a_2 = \frac{I_z - I_y}{I_x} \omega_0 - \frac{C_y \Omega_y}{I_x}, \quad a_3 = -\frac{I_z - I_y}{I_x}, \quad a_4 = \frac{1}{I_x} \\
 b_1 &= \frac{C_z \Omega_z}{I_y}, \quad b_2 = -\frac{C_x \Omega_x}{I_y}, \quad b_3 = -\frac{(I_z - I_x)}{I_y}, \quad b_4 = \frac{1}{I_y} \\
 c_1 &= \frac{(I_y - I_x)}{I_z} - \frac{C_y \Omega_y}{I_z}, \quad c_2 = \frac{C_x \Omega_x}{I_z}, \quad c_3 = -\frac{(I_y - I_x)}{I_z}, \quad c_4 = \frac{1}{I_z}
 \end{aligned}$$

A suitable cost functional which minimizes the satellite kinetic energy is given by

$$J(u) = \int_0^T [\lambda_1 \dot{p}^2 + \lambda_2 \dot{q}^2 + \lambda_3 \dot{r}^2 + u_1^2 + u_2^2 + u_3^2] dt \quad (4.4)$$

for λ_1, λ_2 and $\lambda_3 > 0$ and $t \in (0, T]$.

Equations (4.3) and (4.4), in matrix notation, can be written as

$$\dot{x} = Ax + Bu + f(x, t) \quad (4.5)$$

$$J(u) = \int_0^T [x'Qx + u'Pu] dt$$

where $x = (p, q, r)'$ and $u = (u_1, u_2, u_3)'$. The matrices A, B, f, Q and P are given by

$$A = \begin{bmatrix} 0 & a_1 & a_2 \\ b_1 & 0 & b_2 \\ c_1 & c_2 & 0 \end{bmatrix}, \quad B = \begin{bmatrix} a_4 & 0 & 0 \\ c & b_4 & 0 \\ c & 0 & c_4 \end{bmatrix}$$

$$f = \begin{bmatrix} a_3 \text{ gr} \\ b_3 \text{ pr} \\ c_3 \text{ gr} \end{bmatrix}, \quad Q = \begin{bmatrix} \lambda_1 & c & 0 \\ 0 & \lambda_2 & c \\ 0 & 0 & \lambda_3 \end{bmatrix}$$

$$\text{and} \quad R = [I].$$

In the special case, where $\Omega_x = \Omega_y = \Omega_z = 0$ and $\lambda_1 = \lambda_2 = \lambda_3$, it is important to note that the optimal control problem (4.5) has an analytical solution [7].

Using system equation (4.5) and the algorithm developed in section 3.3, linear and nonlinear feedback controls can be computed as indicated in the following section.

4.2

STRUCTURE OF OPTIMAL FEEDBACK REGULATOR

In this section the algorithm developed in section 3.3 is used to generate the sequence of controls $u_*^{(k)}$. Using this technique we have computed the feedback control up to third order. Once the terms $u_*^{(1)}$, $u_*^{(2)}$, $u_*^{(3)}$ are found, linear, non-linear second order and third order controls can be expressed as follows

$$\begin{aligned}
 (1) \quad W &= u_{*}^{(1)}(x, t) = -F^{-1} E' K_{*}^{(1)}(t) x \\
 (2) \quad W &= u_{*}^{(1)}(x, t) + u_{*}^{(2)}(x, t) = -F^{-1} E' (K_{*}^{(1)}(t) x \\
 &\quad + 1/2 [J_{*}^{(3)}(x, t)]_x \\
 (3) \quad W &= u_{*}^{(1)}(x, t) + u_{*}^{(2)}(x, t) + u_{*}^{(3)}(x, t) = -F^{-1} E' (K_{*}^{(1)}(t) x \\
 &\quad + 1/2 [J_{*}^{(3)}(x, t)] + 1/2 [J_{*}^{(4)}(x, t)]_x
 \end{aligned} \tag{4.7}$$

Using the above expressions, the effect of the feedback regulators $W^{(1)}$, $W^{(2)}$ and $W^{(3)}$ on the system behaviour is discussed in the next section.

4.3 EFFECTIVENESS OF FEEDBACK REGULATORS

In order to study the effect of the regulators $W^{(1)}$, $W^{(2)}$, $W^{(3)}$, given by (4.7), on the system behaviour, the following factors have been considered :

- a- The distance of the state $(p, q, r)'$ from the origin and its variation with time.
- b- The behaviour of different regulators.
- c- The cost corresponding to each regulator.
- d- The size of the domain over which each regulator is stable.

For the purpose of numerical simulation, the parameters $I_x, I_y, I_z, C_x, C_y, C_z$ and w_0 , which are given in chapter (II), are used for system (4.3). Further, the weighting factors λ_1, λ_2 , and λ_3 in (4.4) are chosen as

$$\lambda_1 = 0.645, \quad \lambda_2 = 0.1, \quad \lambda_3 = 0.669.$$

Using the above parameters, the system differential equation

$$\dot{x} = Ax + Bu(x,t) + f(x,t) \quad (1)$$

can be solved using Runge-Kutta technique. For $u=W$, let $(P_1(t), q_1(t), r_1(t))$ denote the state of the space craft and let the corresponding distance denoted by $d_1(t)$. Similarly, for $u=W^{(2)}$ and $u=W^{(3)}$, we have the corresponding distances denoted by $d_2(t)$ and $d_3(t)$, respectively. The numerical results obtained for the state $(p_i(t), q_i(t), r_i(t))$, the controls $W^{(1)}$ and the distances $d_i(t)$, under the given initial perturbations, are shown in figures 4.1-4.18.

From these results one observes the following :

(i) Under the given initial perturbations ($d(C) = 0.866, 1.368$ and 13.164), system regulation using non linear second order control ($W^{(2)}$) is comparatively better than that obtained by linear and non-linear third order controls ($W^{(1)}$ and $W^{(3)}$) (see figs. 4.1-4.12).

(ii) When non-linear third order control is applied, regulation becomes poor and system oscillates (see figs. 4.1-4.8).

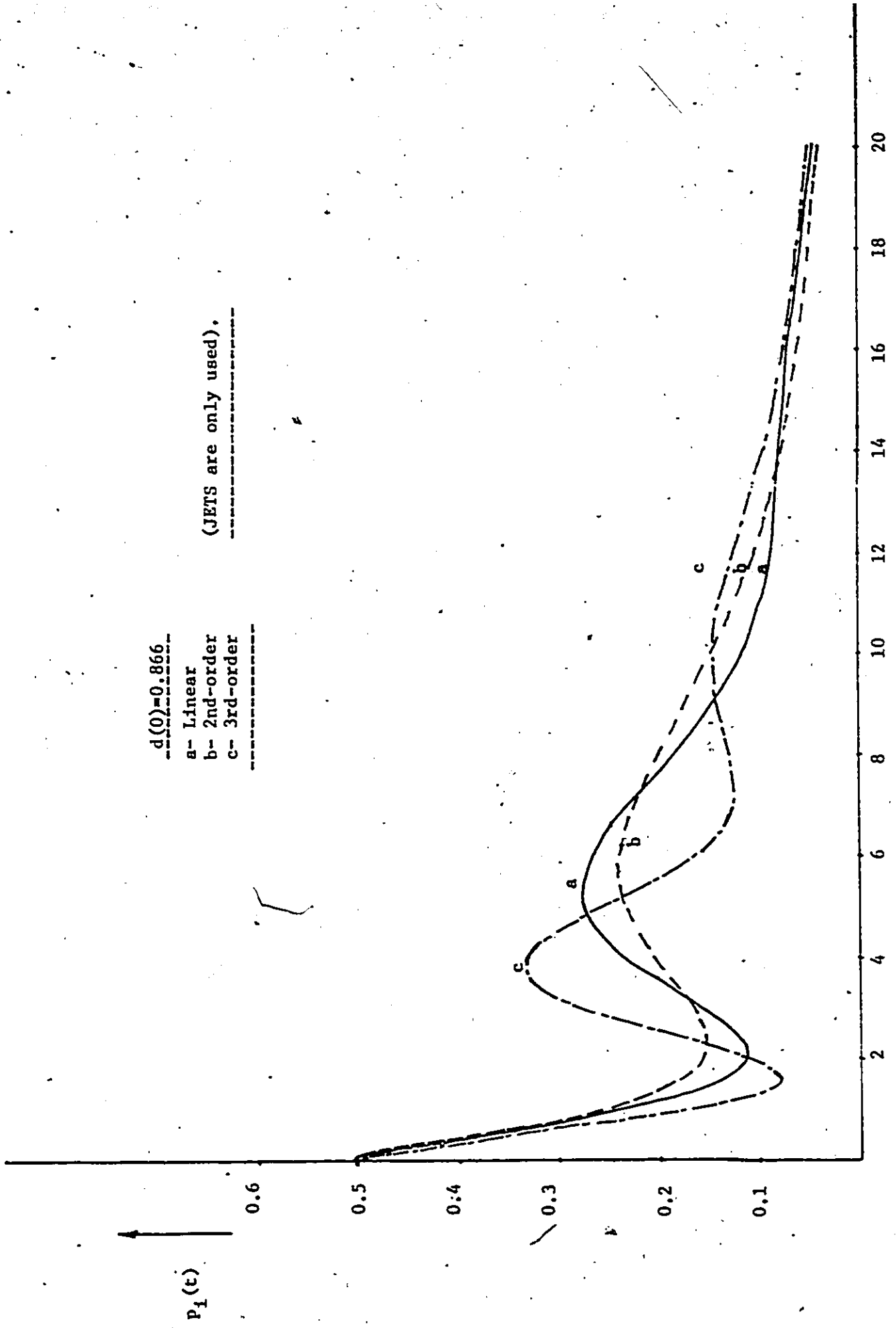

Fig. 4.1 Satellite angular momentum in x-axis.

$d(0) = 1.368$

a- linear

b- 2nd-order

c- 3rd-order

(JETS only are used)

$P_1(t)$

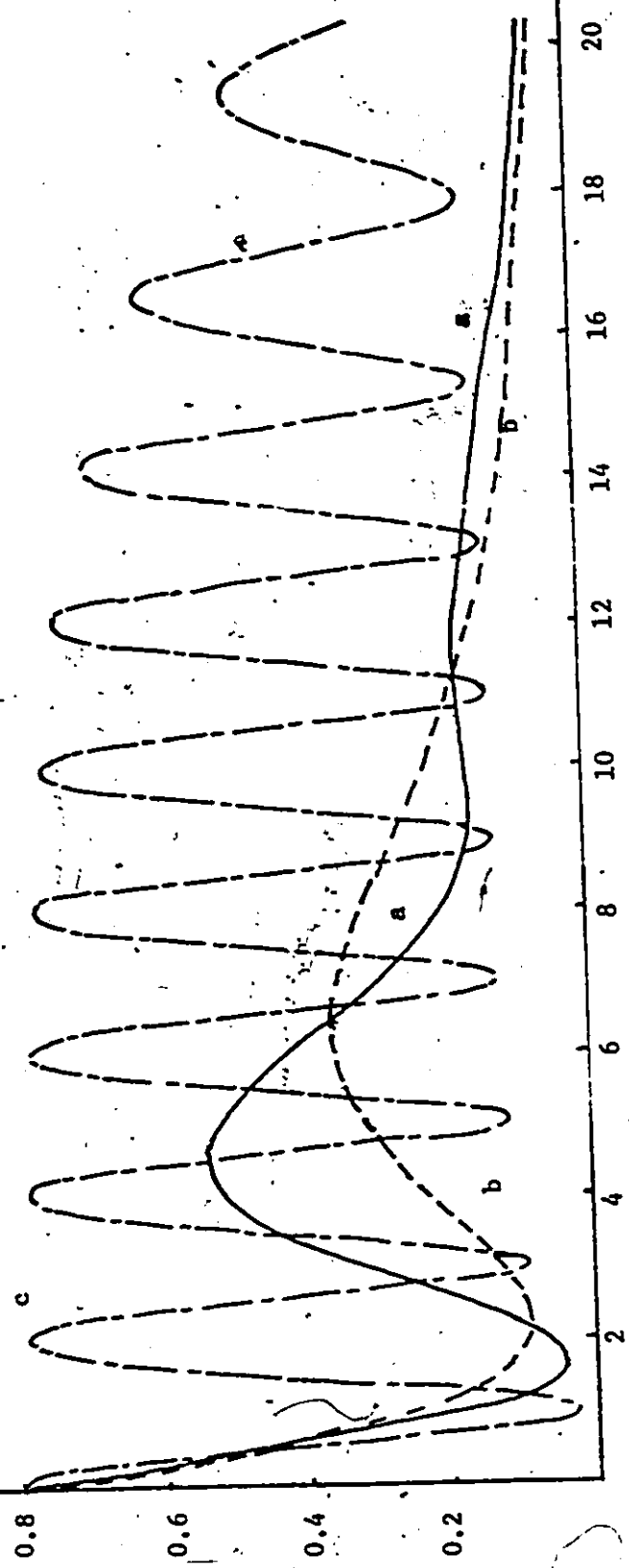

Time sec.

Fig. 4.2 Satellite angular momentum in the x-direction.

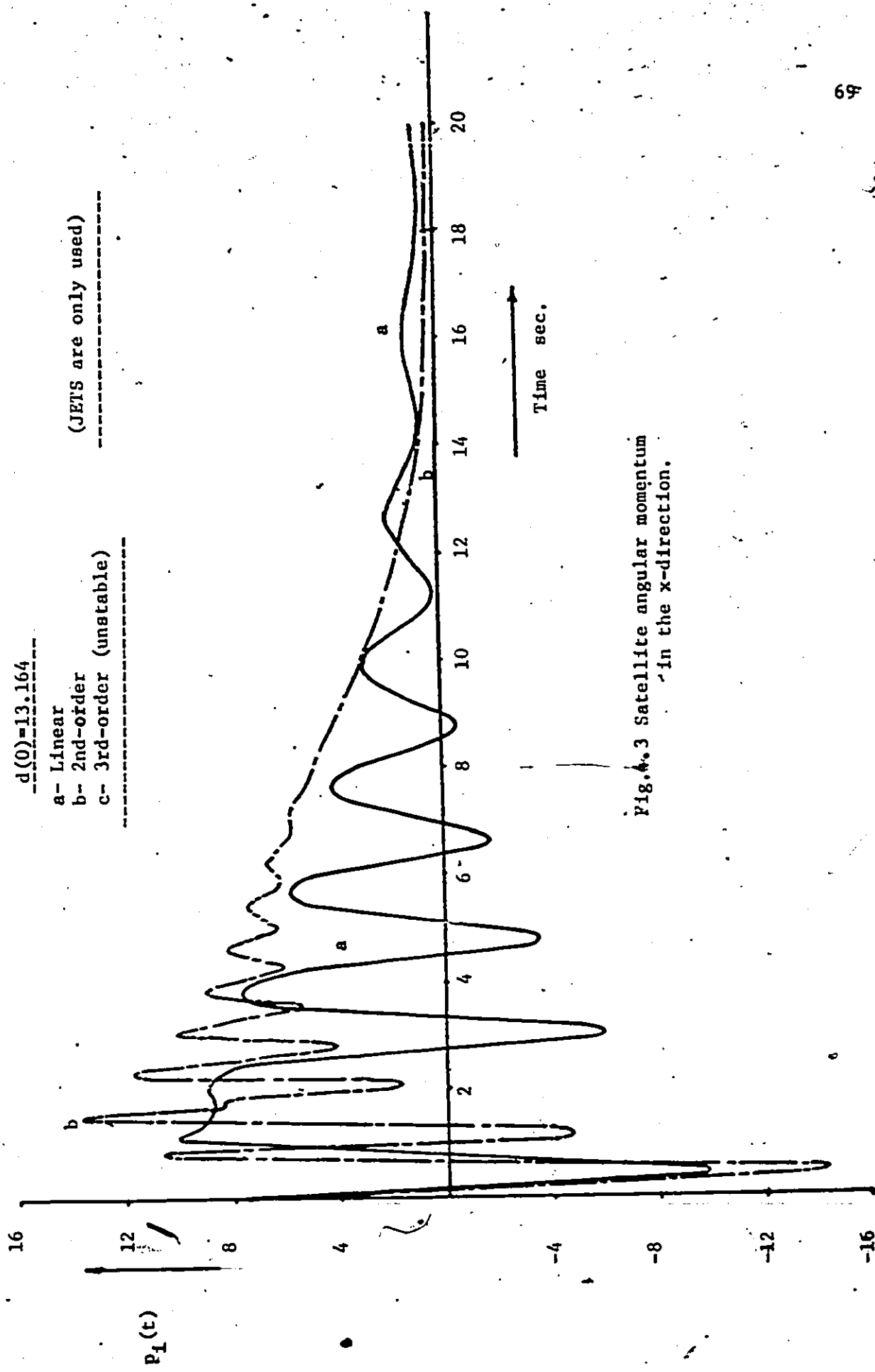
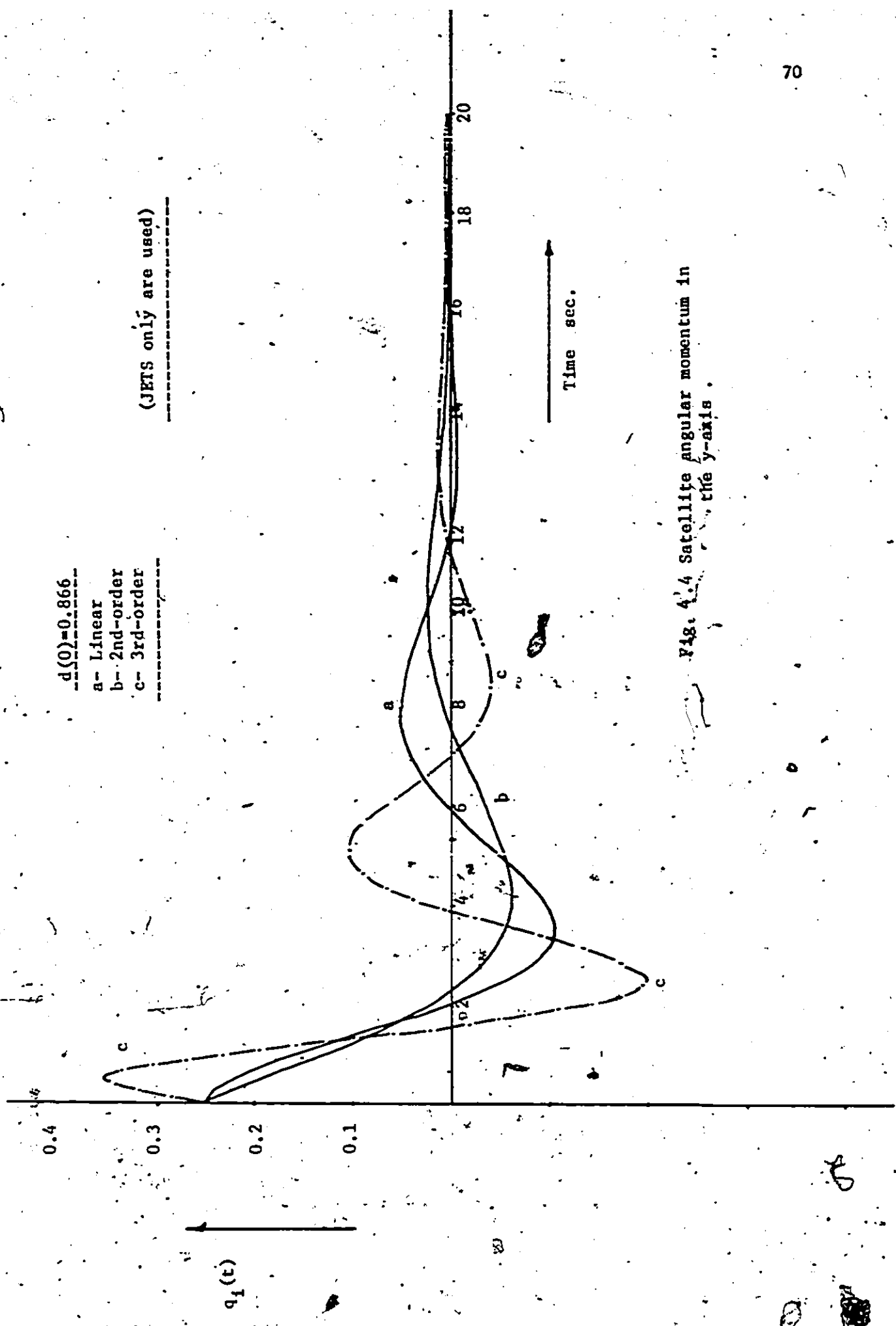

Fig. 4.3 Satellite angular momentum in the x-direction.



$d(0)=0.866$

- a- Linear
- b- 2nd-order
- c- 3rd-order

(JETS only are used)

Fig. 4.4 Satellite angular momentum in the y-axis.

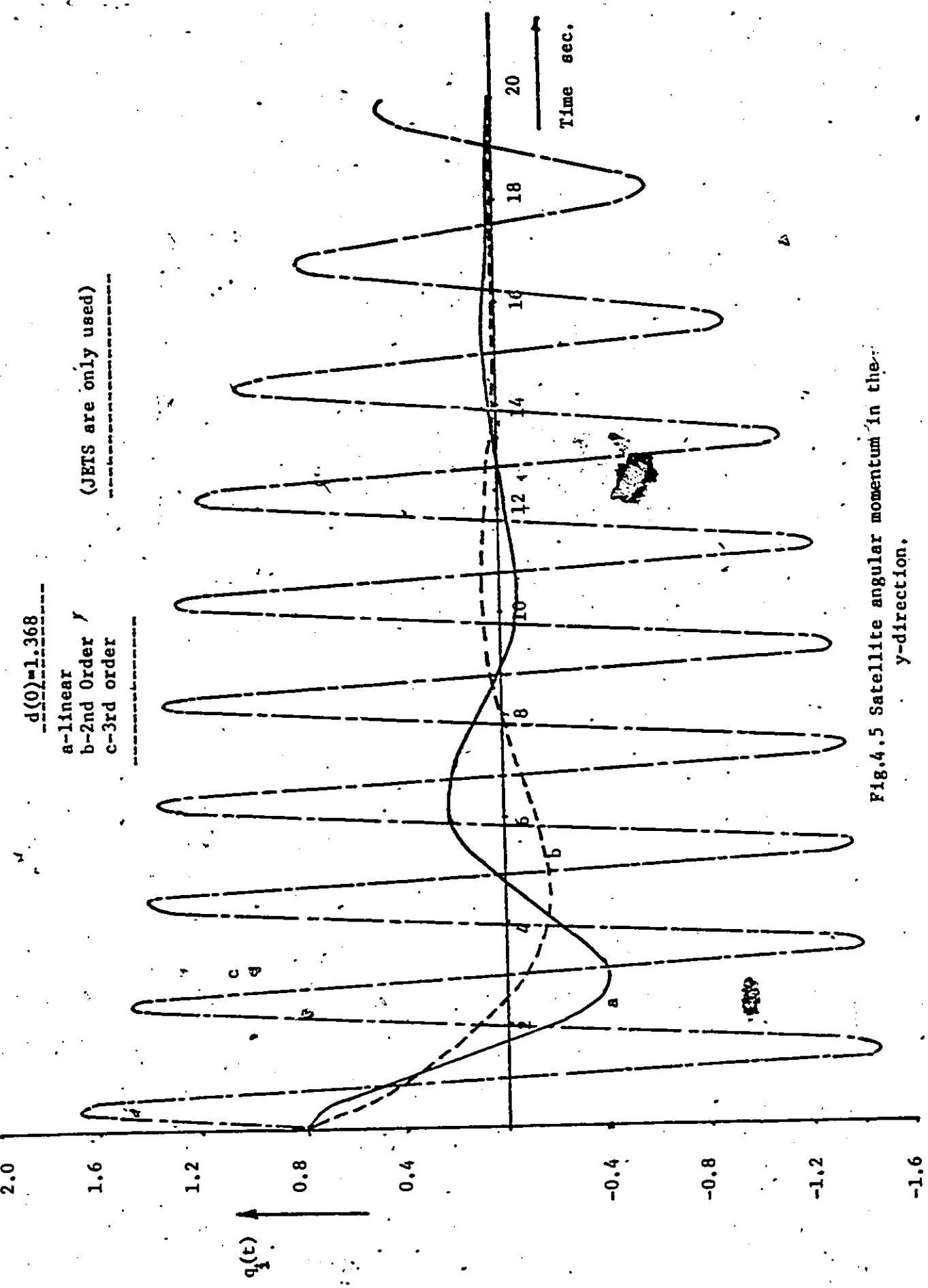

Fig.4.5 Satellite angular momentum in the y-direction.

$d(0)=13.164$
a- linear ..
b- 2nd-order ..
c- 3rd-order (unstable)

(JETS are only used)

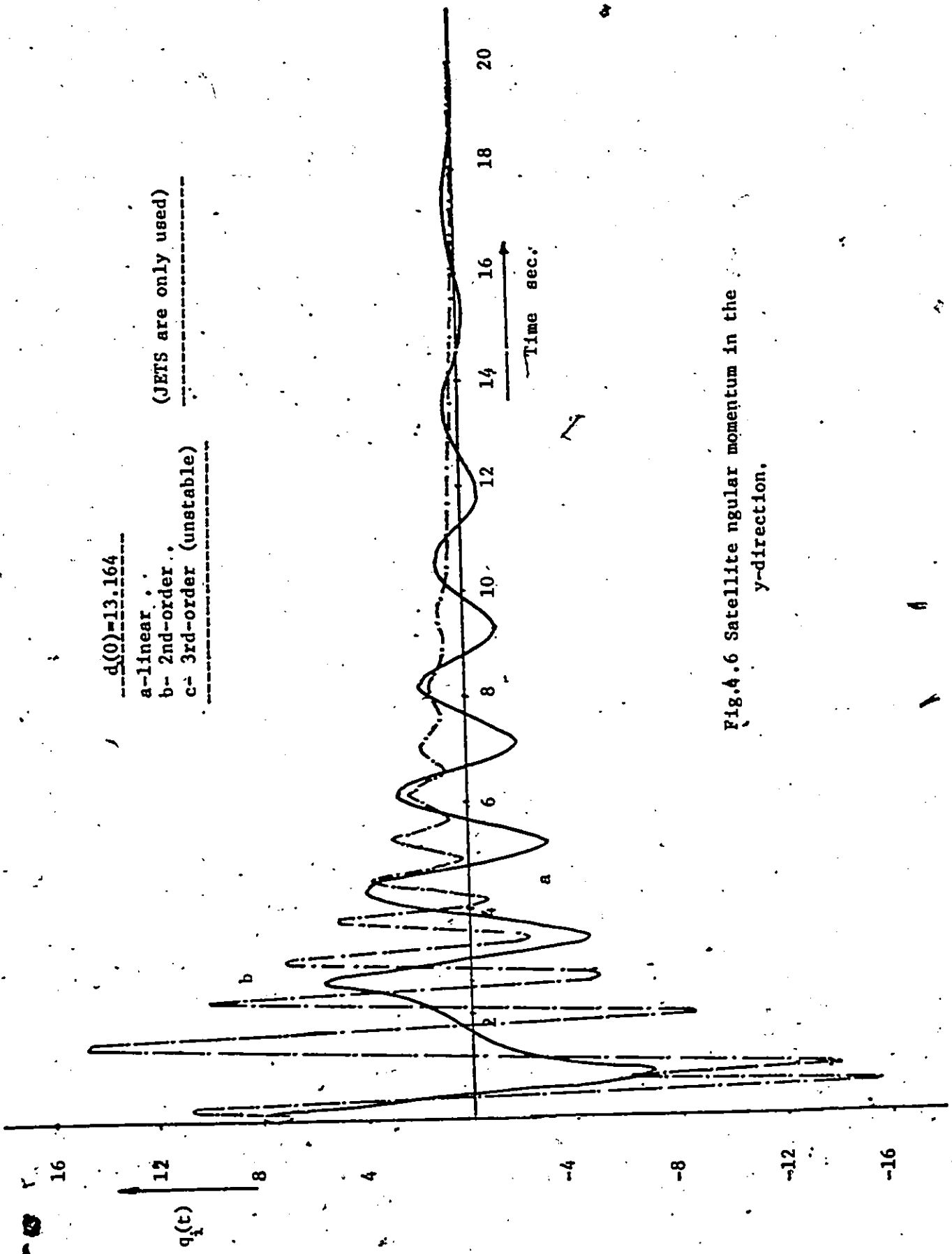

Fig.4.6 Satellite angular momentum in the y-direction.

$d(0) = 0.866$

- a- Linear
- b- 2nd-order
- c- 3rd-order

(JETS only are used)

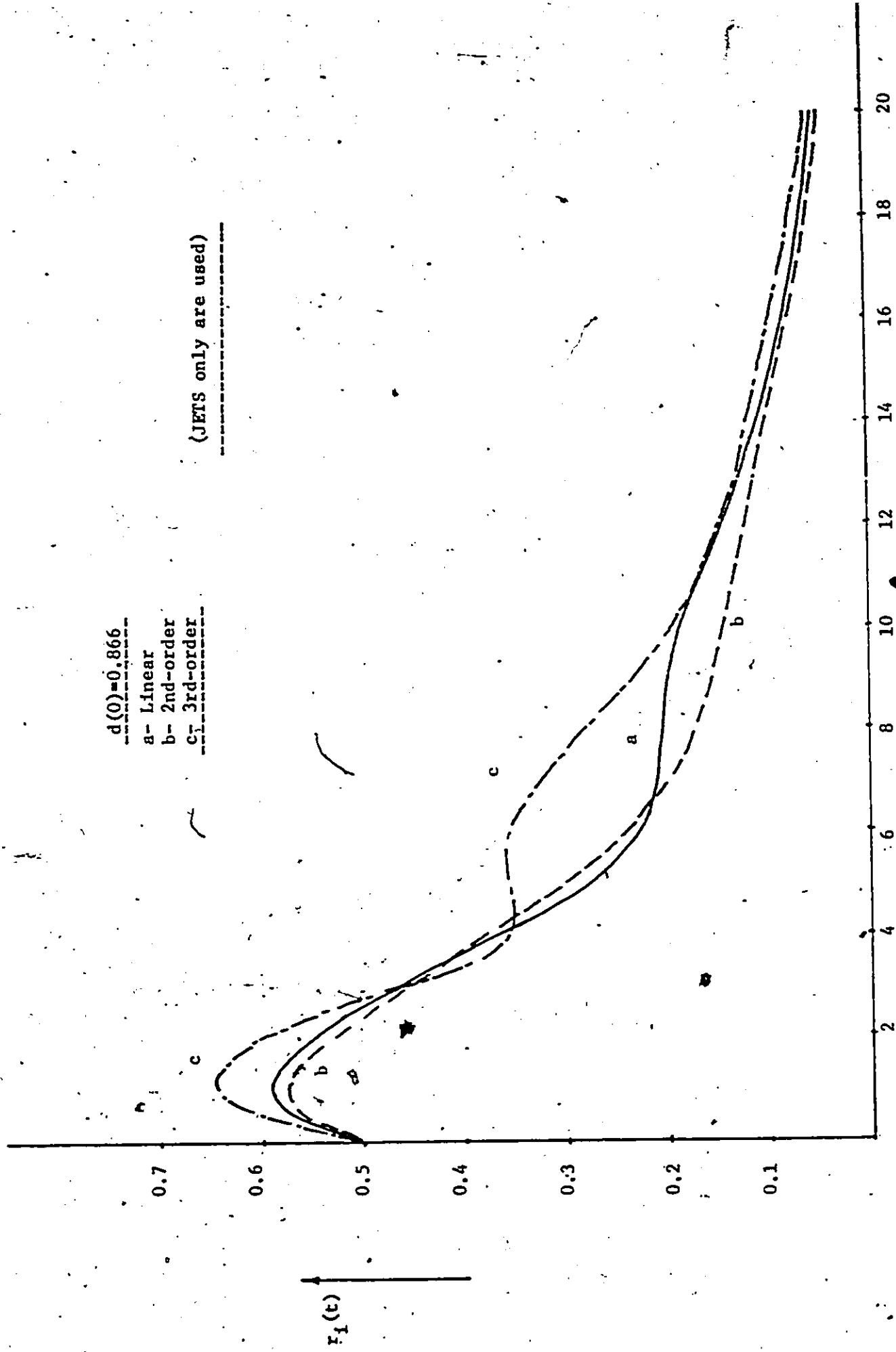

Fig. 4.7 Satellite angular momentum in the z-axis

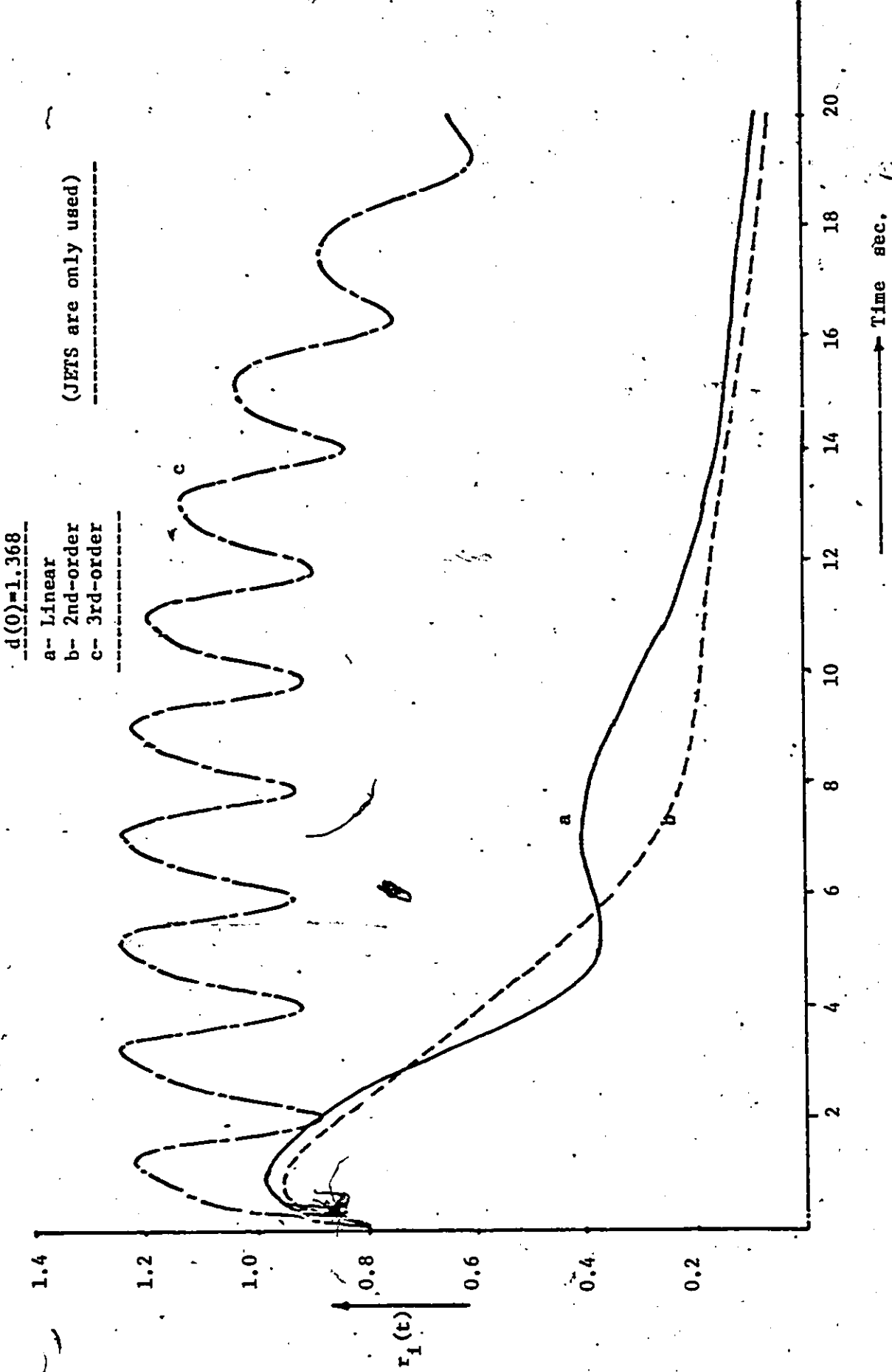

Fig.4.8 Satellite angular momentum in the z-direction.

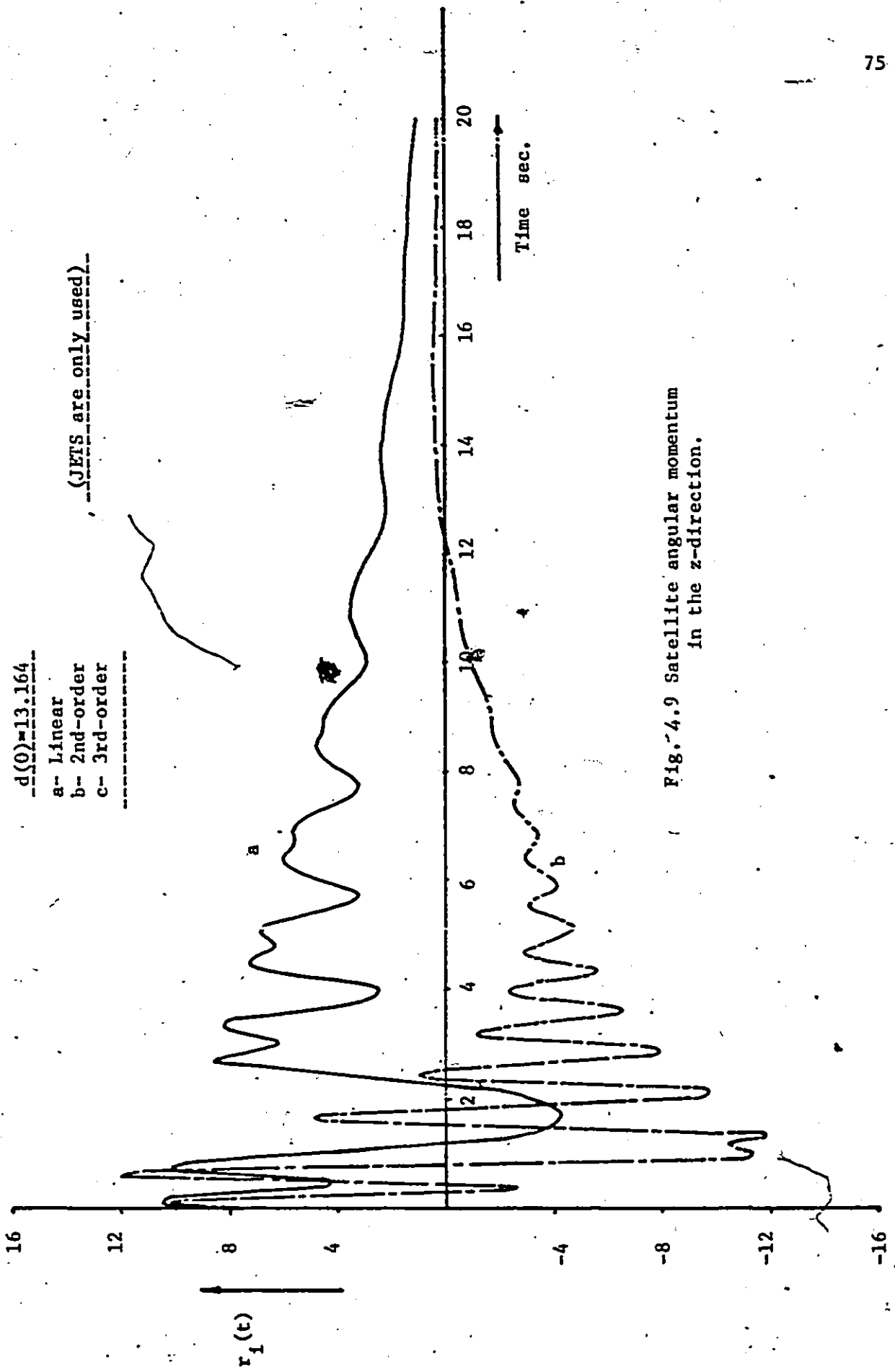

Fig. 4.9 Satellite angular momentum in the z-direction.

$d(0) = 0.866$

a- Linear

b- 2nd-order

c- 3rd-order

(JETS only are used)

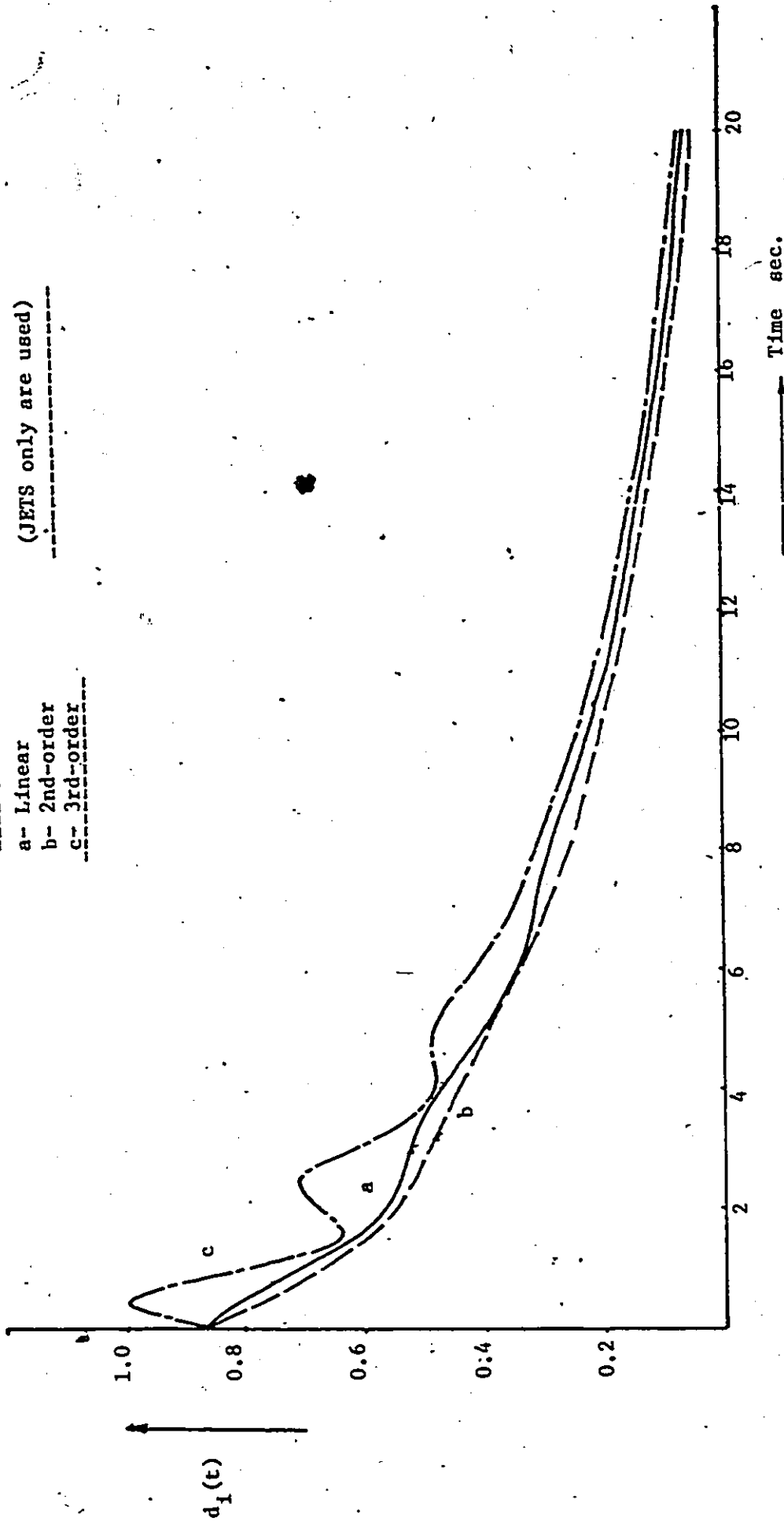

Fig. A.10 Distance from the state to the origin.

$d(0) = 1.368$

- a- Linear
- b- 2nd-order
- c- 3rd-order

(jets only are used)

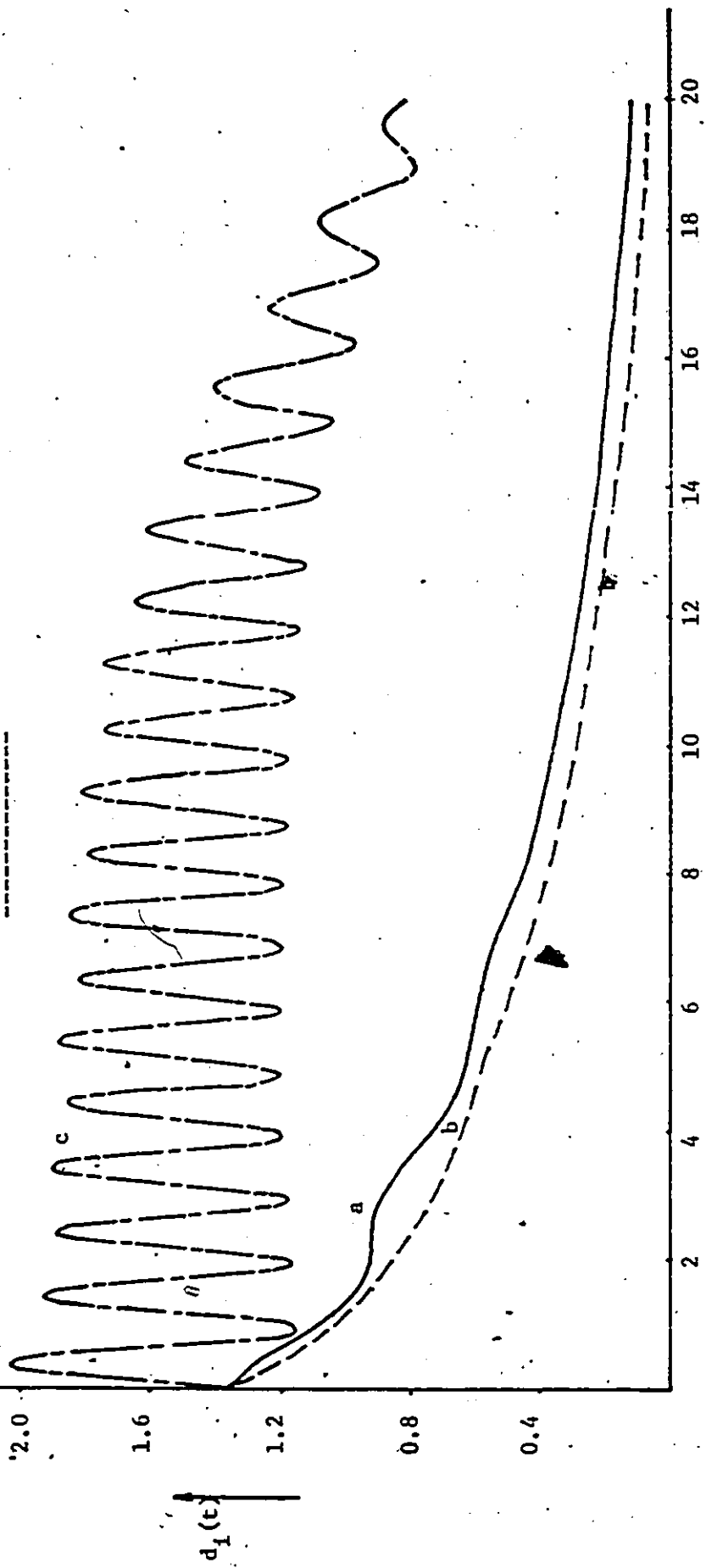

Fig.4.11 Distance from the state to the origin

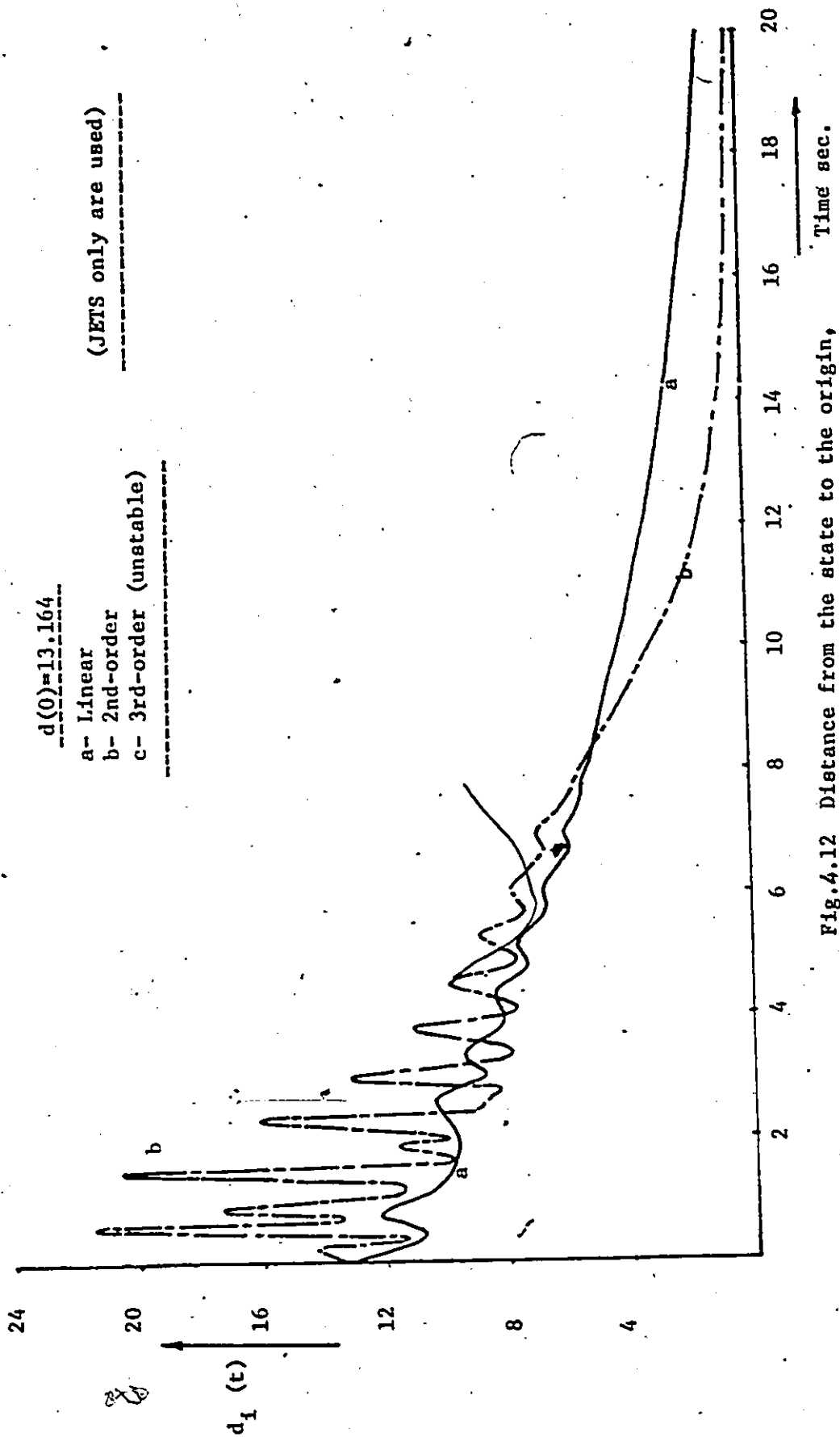

Fig.4.12 Distance from the state to the origin,

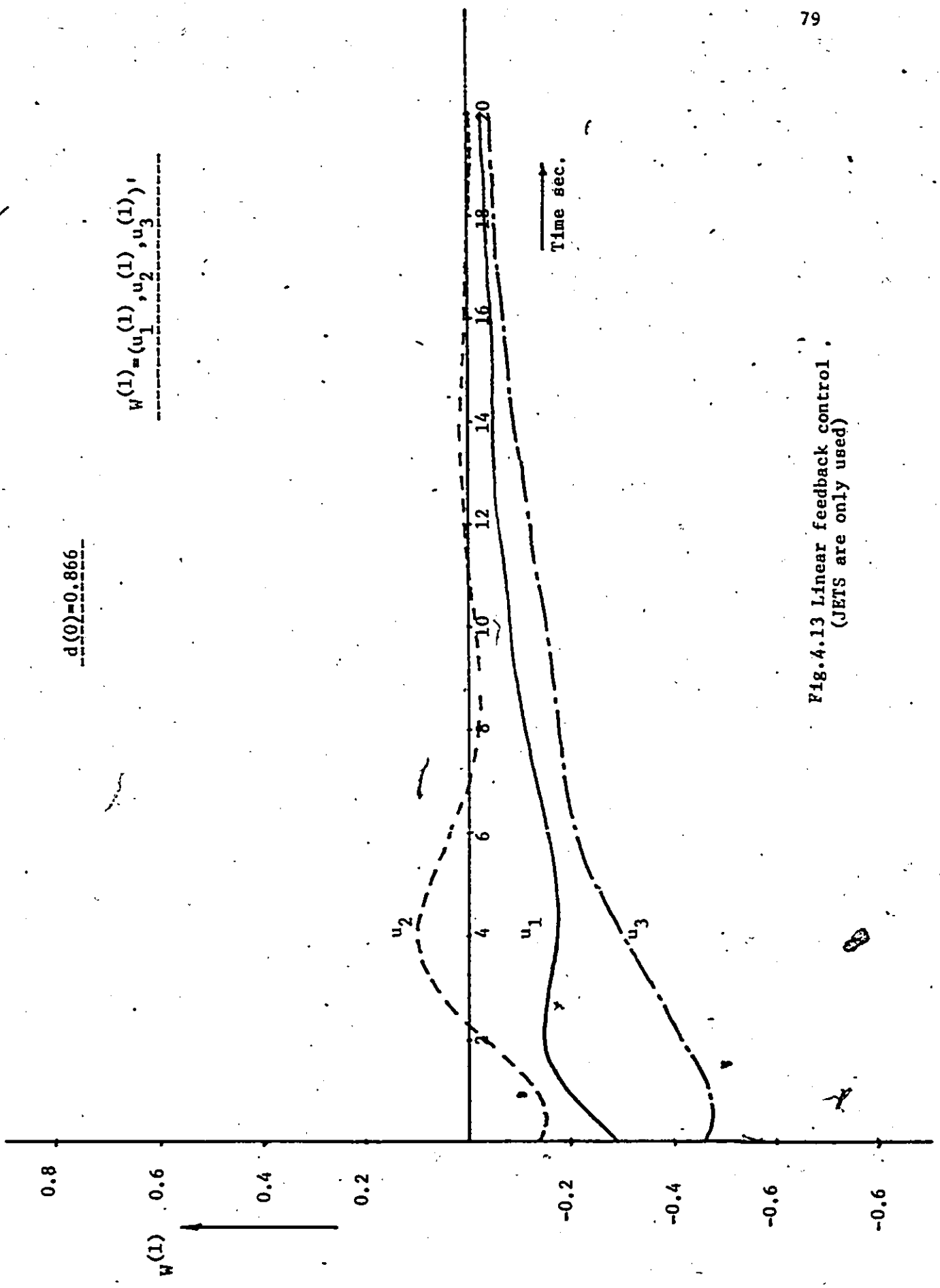

Fig. 4.13 Linear feedback control .
(JETS are only used)

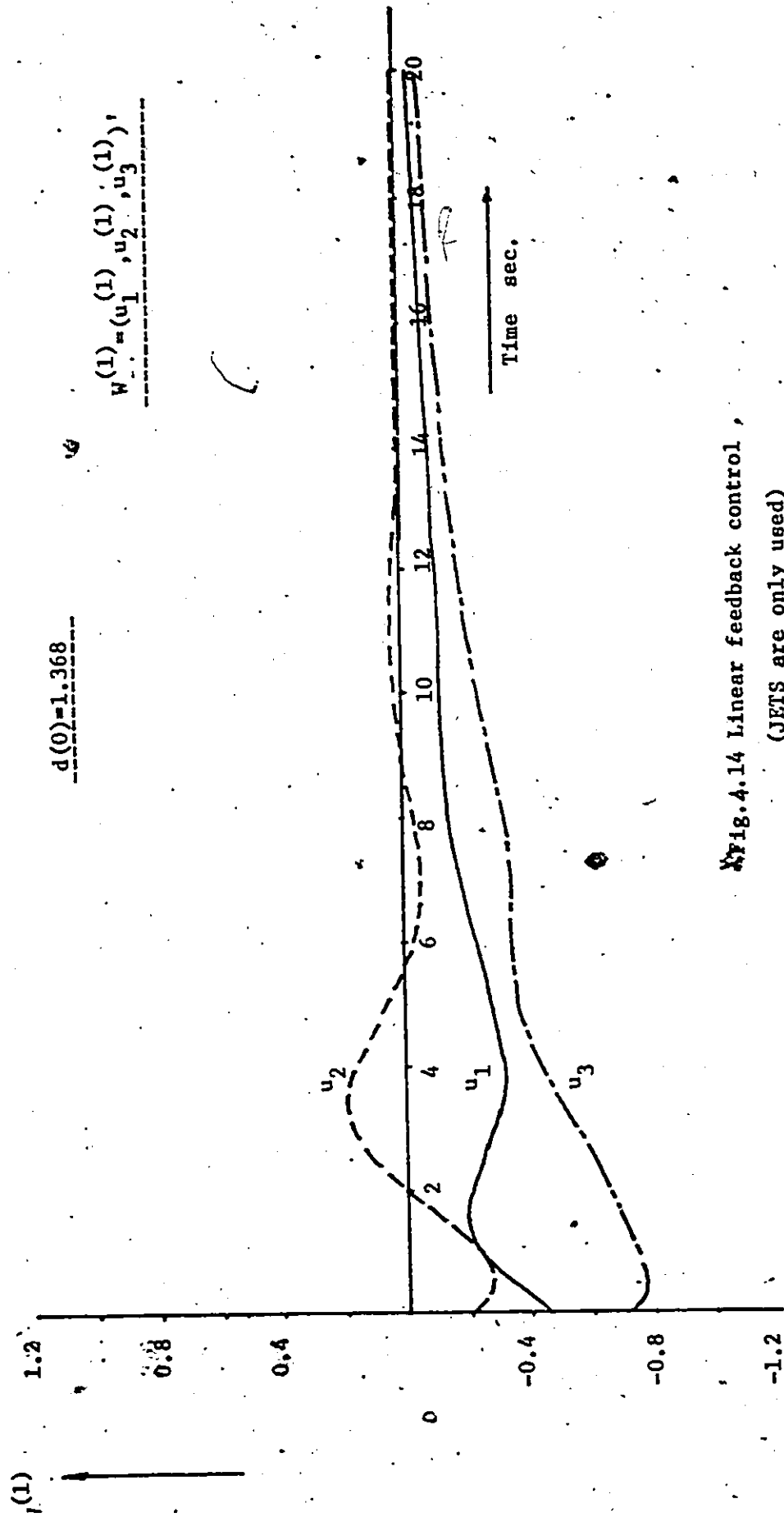
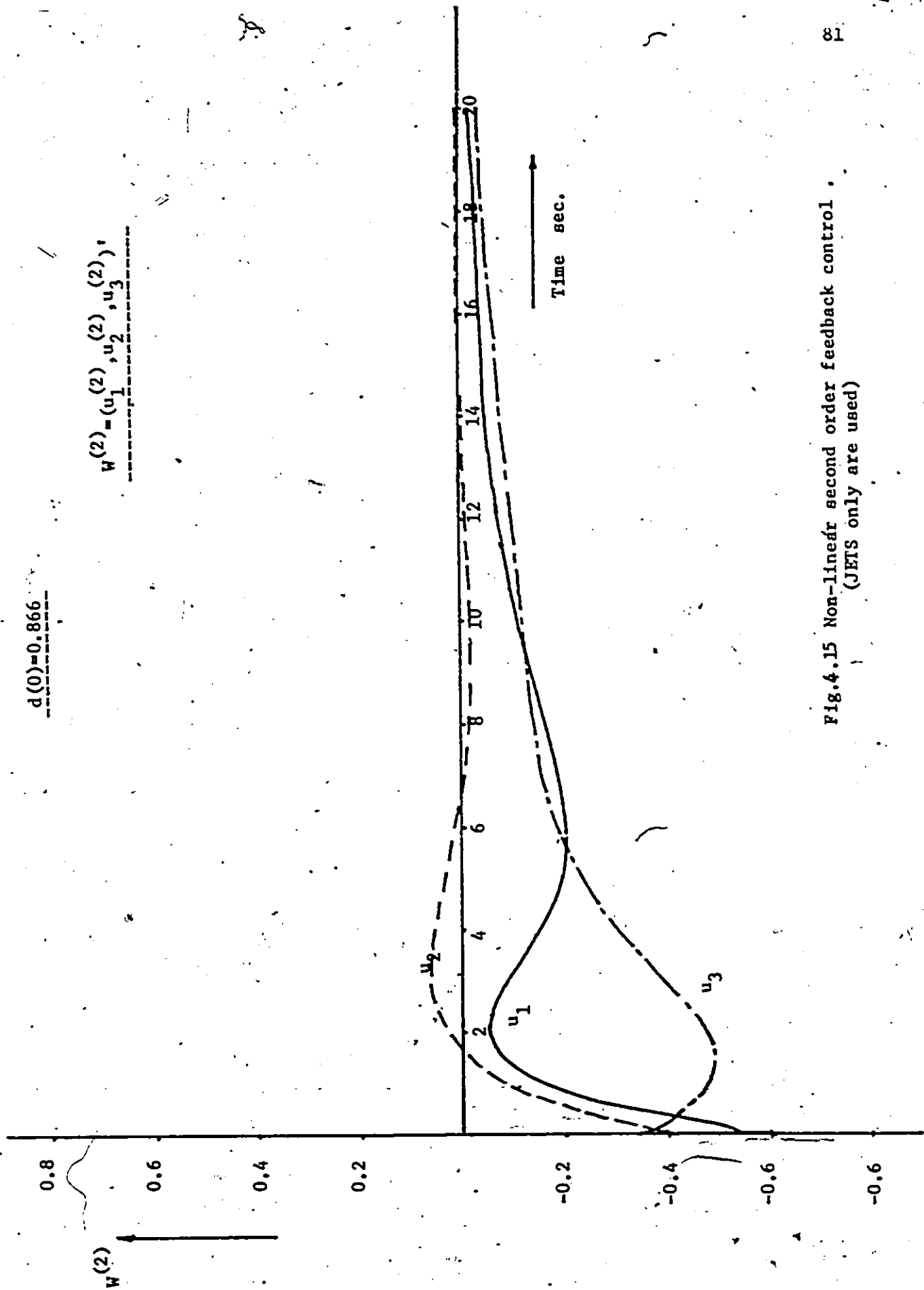

Fig. 4.14 Linear feedback control, (JETS are only used)



$d(0)=0.866$

$W(2) = (u_1^{(2)}, u_2^{(2)}, u_3^{(2)})$

Fig.4.15 Non-linear second order feedback control .
(JETS only are used)

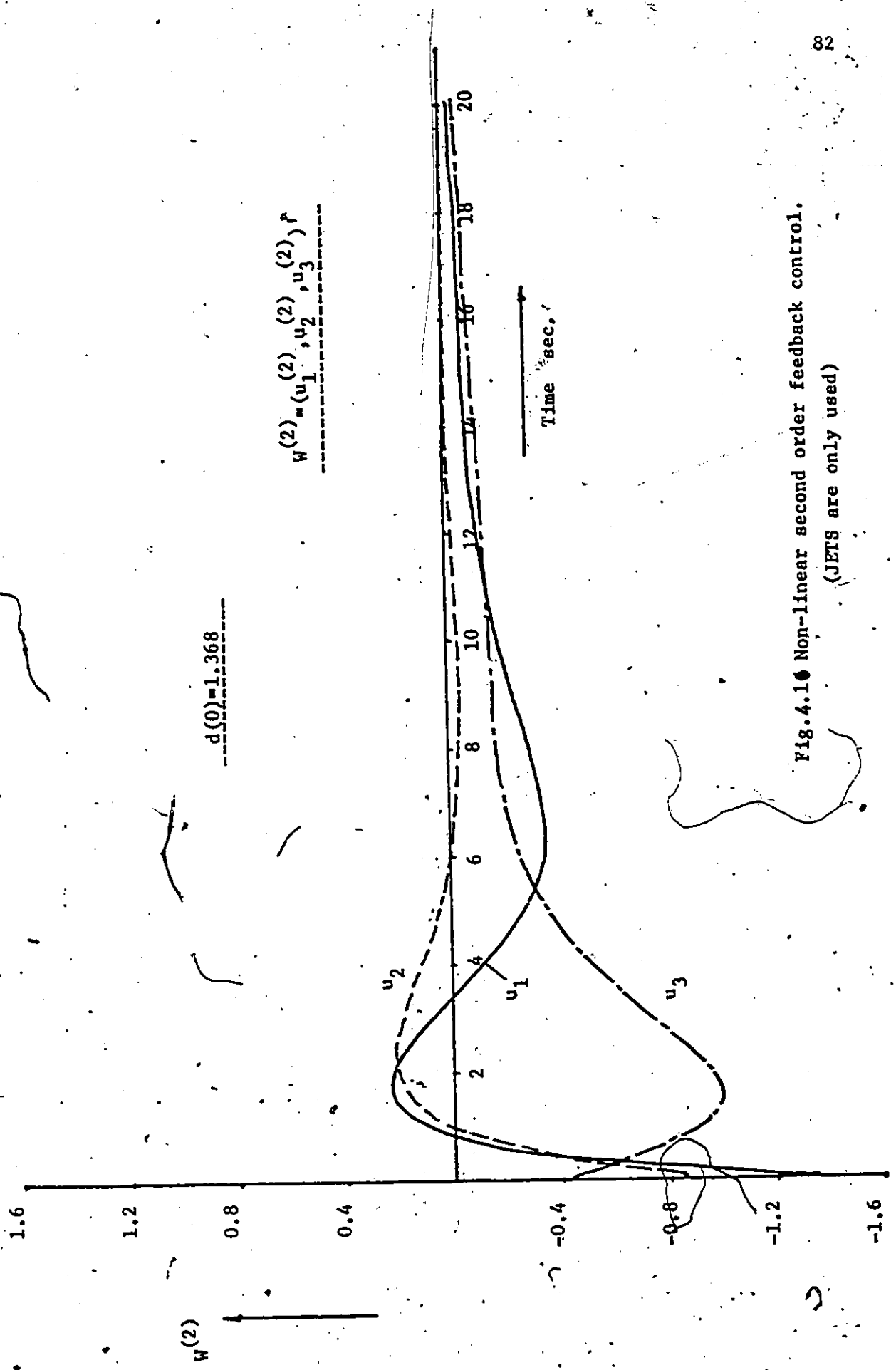

Fig. 4.16 Non-linear second order feedback control.
(JETS are only used)

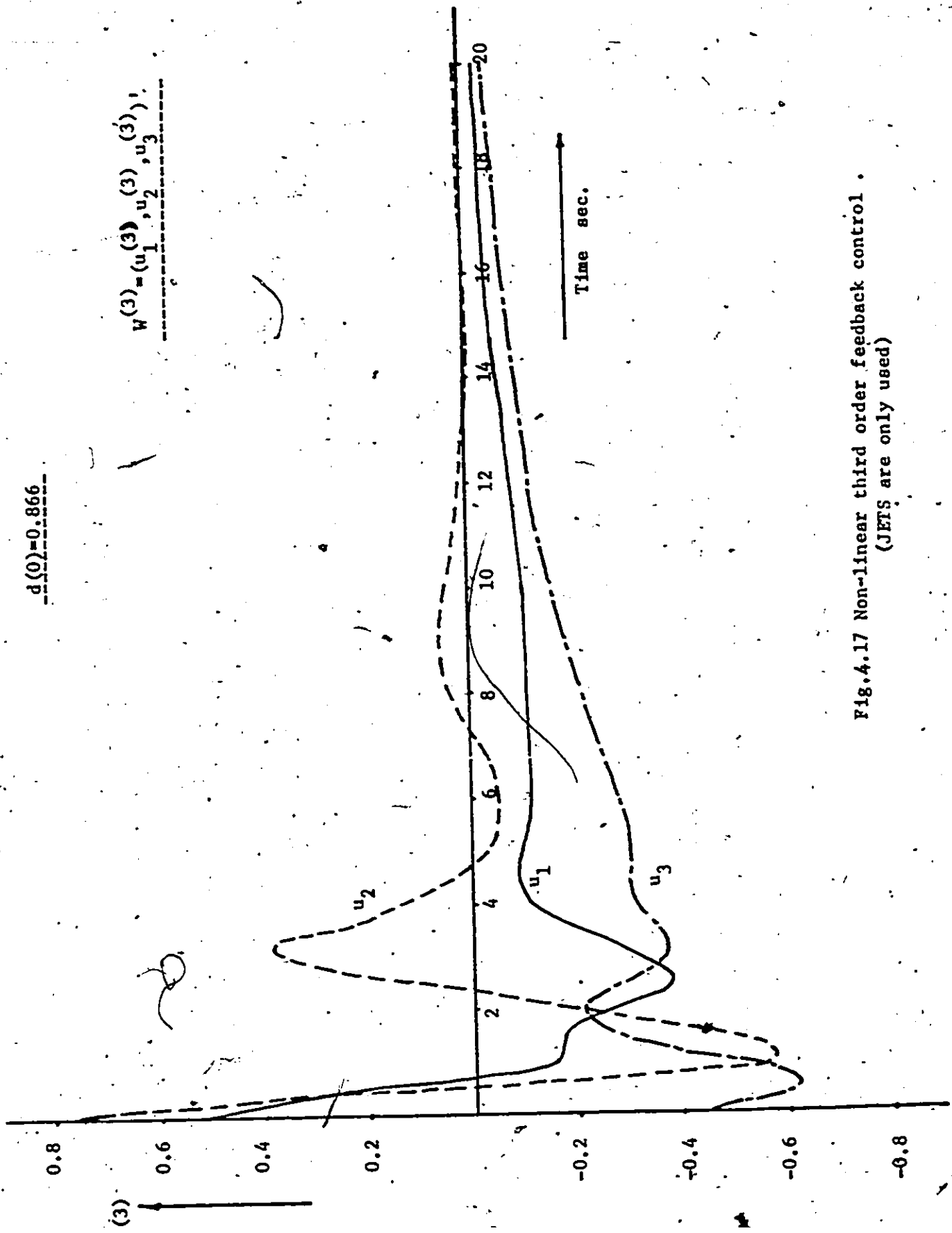

Fig. 4.17 Non-linear third order feedback control .
(JETS are only used)

$d(0) = 1.368$

$w^{(3)} = (u_1^{(3)}, u_2^{(3)}, u_3^{(3)})$

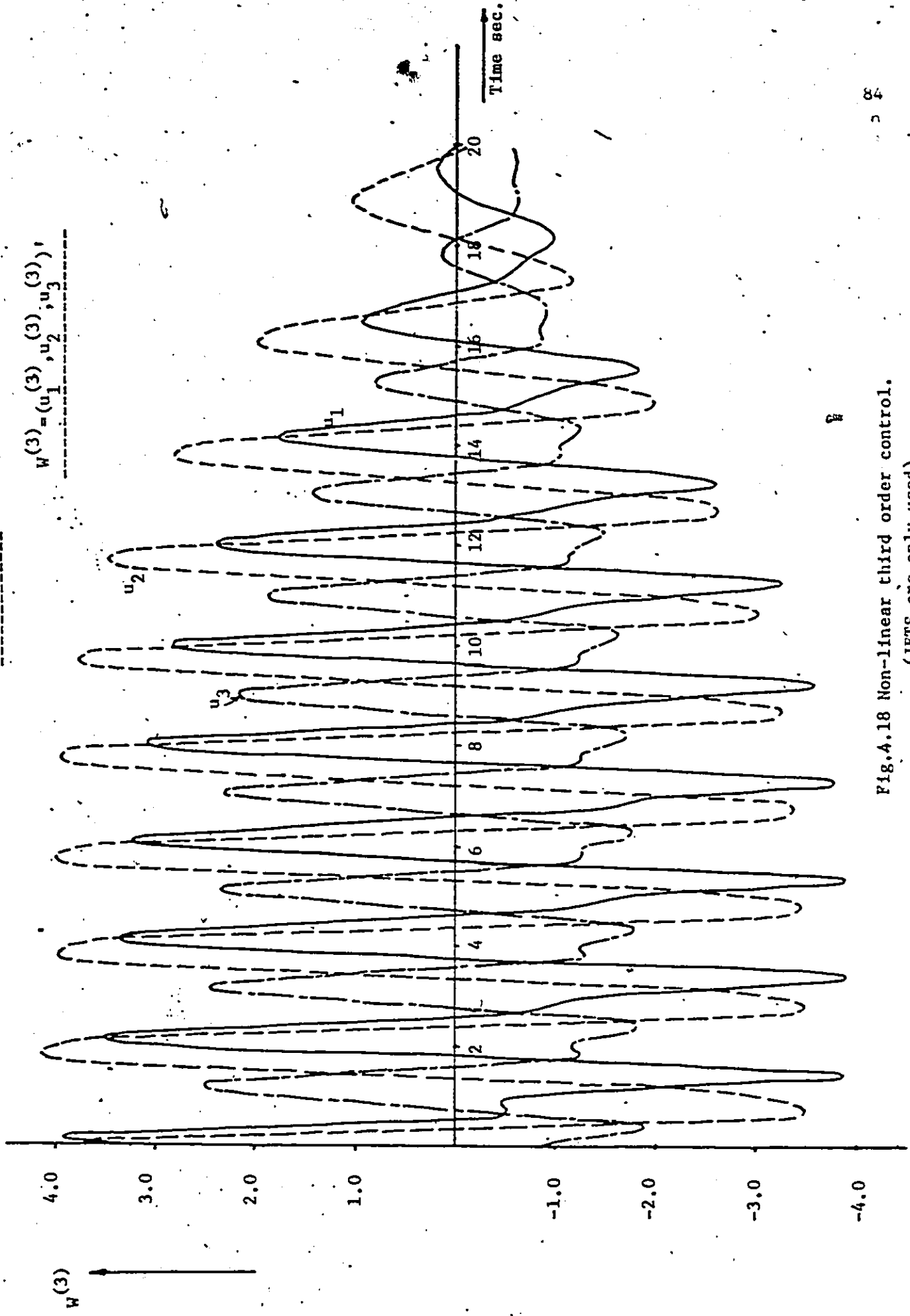

Fig. 4.18 Non-linear third order control.
(JETS are only used).

(iii) For some perturbations ($d(0) > 1.368$), non-linear third order control fails to regulate the system (becomes unstable). On the other hand, system regulation can be achieved by linear and second order controls (see figs. 4.3, 4.6, 4.9 and 4.12).

(iv) For very large perturbations ($d(0) > 13.164$), non-linear second order control becomes unstable and regulation, in this case, can only be achieved by linear regulator.

TABLE I

CONTROL	LINEAR	2nd order	3rd order
SIZE OF STABILITY DOMAIN	$0 < d < \infty$	$0 < d < 13.164$	$0 < d < 1.368$

TABLE II

REGULATOR	COST CORRESPONDING TO EACH REGULATOR		
	$\delta(0) = 0.866$	$\delta(0) = 1.368$	$\delta(0) = 13.164$
LINEAR	2.67	6.9	70
2nd CRDEF	2.79	7.45	85
3rd CRDEF	3.79	22	UNSTABLE

In the above tables, the numerical results obtained for the size of stability domain of each regulator and the corresponding cost, under different initial perturbations, are presented. From these results it is clear that system (4.5), when linear control is applied, is globally stable (this results agree with those obtained by using Liapunov theory). Further, as the initial perturbation increases the cost corresponding to each regulator also increases and the lowest value is obtained in the case of linear regulator (see table

II). These results are, however, expected because of the following facts :

As indicated earlier, the control sequence $[W]$ can be defined as

$$W^{(i)} = u_*^{(1)} + u_*^{(2)} + \dots + u_*^{(i)} \quad (4.8)$$

where u can be generated by using the algorithm given in section 4.4. It is important to note that the sequence of costs $[J(W^{(i)}), i=1,2,\dots]$, corresponding to the sequence of controls $[W^{(i)}]$ generated by (4.8), is not necessarily a monotone decreasing sequence (i.e., $J(W^{(i+1)}) < J(W^{(i)})$). This is because such constraints were not imposed in the construction of the optimal control suggested in [1,2]. However, if there exists an optimal feedback control $u_*(x,t)$, for $x \in \mathbb{R}^n$ and $t \in [t_0, T]$, from the admissible class and if the sequence $W^{(i)} \rightarrow u_*$ in some appropriate topology then we can expect that for all i greater than some i_0 , the inequality

$$J(W^{(i+1)}) < J(W^{(i)}), \quad i > i_0$$

holds provided that the cost functional J is continuous. Further, for all $i < i_0$, the sequence of controls $[W^{(i)}]$ is not optimal and consequently by Lemma 1.5 we can not assert that the system

$$\dot{x} = F(x(t), W^{(i)}(x,t), t)$$

is asymptotically stable.

From the above discussion, it is clear that in order to compute the optimal feedback control $u^*(x,t)$, using the results developed in [1,2], all the higher order terms in series (4.8) should be included. However, as the order of the sequence $[W^{(i)}]$ increases, the number of differential equations one needs to solve every step also increases (see steps (ii), (iii) and (iv) in section 4.2). In table III, the number of differential equations required to generate the series (4.8), for system (4.5), is indicated.

From this table, it is clear that even in the case of a three dimensional problem the number of differential equations one needs to solve in order to compute the optimal control, is quite large. Obviously, in the case of large scale system, obtaining the optimal control, using the previous algorithm, requires solving a larger number of differential equations. This difficulty can be considered as a major problem in the application of this theory.

TABLE III

(i)	NO. OF DIFFERENTIAL EQUATIONS
(2)	10
(3)	15
(4)	21
(5)	27
(6)	36

4.4 SUMMARY

In this chapter, the theory developed in [1,2] has been applied for study of optimal regulation of a satellite using reactive jets with flywheels having fixed angular velocities. For this problem, it was found that, under the given initial perturbations, better regulation can be obtained by using nonlinear second order control. When third order control is applied, regulation becomes poor and system oscillates. Using Liapunov theory, it was found that system (4.5), when linear control is applied, is asymptotically stable. Further, as the initial perturbation increases, the cost corresponding to each regulator also increases and the lowest value is obtained in the case of linear control. However, as indicated earlier, by including all the higher order terms in series (4.8) system behaviour and the cost of the corresponding regulator can be improved. The only difficulty in introducing those higher order terms is the large number of differential equations one needs to solve every step to generate the control sequence $u_*^{(i)}$ in series (4.8).

Chapter V
CONCLUSIONS

In this thesis, the theory of optimal feedback control developed in [1,2] has been presented. The proof of the existence of a unique optimal control, in the case of the free end problem, is given. The methods which can be used to compute linear as well as non-linear optimal feedback controls were indicated. Further, with the aid of Liapunov theory, it was shown that the optimally regulated system (2.7) is necessarily stable.

For the optimal regulation problem presented in chapter (II), a suitable control model, which minimizes the cost of fuel and energy, has been developed using a combination of reaction jets (for larger perturbations) and flywheels for (mild perturbations). Using such a model, we have observed that for the given initial perturbations system regulation using non-linear second order control is comparatively better than that obtained by linear control. As the region, over which reaction jets operate, is shrunked, the corresponding cost of fuel required to run the jets is reduced. In this case, longer time is required for the system to attain the rest (desired) state. On the other hand, as the jets operating region increases (i.e., r decreases), system regula-

tion is improved but the fuel cost is much higher. However, using the control model developed in fig.3.1, one can choose a suitable region of operation for the reaction jets (by changing r) such that the system can attain the rest state fairly fast with reasonable fuel cost.

In the second control problem, as presented in chapter (III), the optimal regulation of a satellite angular momentum dynamics, using reaction jets with flywheels having fixed angular velocities was considered. For this problem it was found that under some reasonable initial perturbations, better regulation can be obtained by using non-linear second order control. When third order control is applied, regulation becomes poor and system oscillates. Using Liapunov theory, it has been found that system (4.5), when linear control is applied, is asymptotically stable. Further, as the initial perturbation increases, the cost corresponding to each regulator also increases and the lowest cost is obtained in the case of linear control. However, by including all the higher order terms in series (4.8), system regulation and the cost of the corresponding control can be improved. The only difficulty in introducing these higher order terms is the large number of differential equations one has to solve in order to generate the sequence $[w^{(i)}, i=2,3,\dots]$ (see table III). Such difficulty can be considered as a major problem in the application of the theory developed in [1,2], specially for large scale system.

So far no satisfactory result which solves the optimal feedback control problem has been developed. However, the author feels that this problem may be solved by developing a suitable numerical technique which provides solution to Bellman's equation (by solving a system of non-linear partial differential equations). Consequently, the optimal feedback control can be found.

Appendix A

DERIVATION OF THE MATRIX RICCATI EQUATION

Consider the linear-quadratic control process in R^n

$$\dot{x} = A(t)x + B(t)u(x,t)$$

with the performance index

(A1)

$$J(u) = \int_0^T [1/2(Q(t)x, x) + 1/2(u, R(t)u)] dt + x^T M x$$

The basic problem is to find a bounded feedback control $u(x,t)$ which minimizes the above integral. This problem can be solved by using Bellman's principle of optimality. For each $t \in [0, T]$ and $x \in R^n$, define

$$V(x,t) = \inf_u \int_t^T [1/2(Q(t)y(x,t), y(x,t)) + 1/2(u(t), R(t)u(t))] dt$$

where

$$\dot{y}(x,\theta) = A(\theta)y(x,\theta) + B(\theta)u(\theta),$$

$$y(x,\theta) = x \quad \text{for } \theta \in [t, T].$$

It is known that V , as defined above, satisfies the Bellman's equation

$$- [V(x,t)]_t = \text{Inf} [(A(t)x + E(t)u, V_x(x,t)) + \frac{1}{2} (Q(t)x, x) + (u, R(t)u)] \quad (A2)$$

with the boundary condition

$$V(x,T) = M \quad \text{for} \quad (x,t) \in \mathbb{R}^n \times [C, T]$$

Since there is no constraint on the control values and $R(t)$ is positive definite, the infimum can be obtained by equating to zero the partial with respect to u of the expression within the bracket in (A2). This gives us

$$u = u_x(x,t) = -B'(t)R^{-1}(t)V_x(x,t) \quad (A3)$$

Substituting (A3) into (A2) we obtain

$$- [V(x,t)]_t = [(A(t)x - B(t)R^{-1}(t)V_x(x,t), V_x(x,t)) + \frac{1}{2} (Q(t)x, x) + \frac{1}{2} [E'(t)R^{-1}(t)V_x(x,t), B'(t)V_x(x,t)]] \quad (A4)$$

Since the system (A1) is linear and J is quadratic, the function V is also quadratic in x . Assuming the quadratic form for this function we can write

$$V(x,t) = \frac{1}{2} (K(t)x, x)$$

where K is an unknown quantity to be determined. Substituting the previous expression into (A4) and noting that

$$\dot{V}_t(x,t) = 1/2(\dot{K}(t)x,x)$$

$$\dot{V}_x(x,t) = 1/2(K(t)x,x) + 1/2(K'(t)x,x)$$

(A5)

we obtain

$$\begin{aligned} -1/2(\dot{K}(t)x,x) &= 1/2[(K(t)A(t) + A'(t)K(t))x,x \\ &\quad - 2(K(t)B(t)E^{-1}(t)B'(t)x,x) + (Q(t)x,x) \\ &\quad + (K(t)B(t)E^{-1}(t)E'(t)K(t)x,x)] \end{aligned}$$

From the previous equation, it follows that

$$\begin{aligned} -\dot{K}(t)x,x &= [(K(t)A(t) + A'(t)K(t))x,x] \\ &\quad - (K(t)E(t)E^{-1}(t)B'(t)K(t)x,x) + (Q(t)x,x) \end{aligned}$$

(A6)

with the boundary condition

$$V(x,T) = 1/2(K(T)x,x) = 1/2(Mx,x)$$

Since equation (A6) is true for all $x \in \mathbb{R}^n$ and $t \in [t_0, T]$, it follows that

$$-\dot{K}(t) = K(t)A(t) + A'(t)K(t) - K(t)E(t)E^{-1}(t)B'(t)K(t) + Q(t)$$

$$K(T) = M$$

(A7)

which is so called the matrix Riccati equation for the system (A1). Further, it follows from (A3) that the optimal control is given by

$$u_*(x,t) = -E^{-1}(t)B'(t)K(t)x$$

REFERENCES

- [1] D.L.Lukes, Optimal Regulation Of Non-linear Dynamical Systems, SIAM Journal, 7(1969), pp.75-100.
- [2] A.F.Willemstien, Optimal Regulation Of Non-linear Dynamical Systems On A Finite Interval, SIAM Journal, 15(1975), pp.1050-1069.
- [3] B.W.Ercckett, Finite Dimensional Linear Systems, John Wiley, NEW YORK, 1970.
- [4] A.I.Greensite, Analysis And Design Of Vehicle Flight Control Systems, NEW YORK, Spartan Book Company, 1970.
- [5] A.Guibord, Satellite Attitude Control Using Optimal Control Theory, Master Thesis, Elec. Eng. Dep., University Of Ottawa, 1978.
- [6] D.L.Lukes, Stabilizability And Optimal Control, Funkcial.Ekvac., 11(1968), pp.39-50.
- [7] B.W.WONG, Suboptimal Control Of Satellite Moments In A Noisy Environment, IEEE Transactions On Aerospace And Electronic Systems, March 1978, pp. 368-371.
- [8] T.E.Dabbous And N.U.Ahmed, Non-linear Optimal Feedback Regulation Of Satellite Angular Moments, IEEE Transactions On Aerospace And Electronic Systems, Vol.17, Nov.1981 (To Appear).

```

// JOB , 'DABBJUS T.E ', MSGLEVEL=(2,0).
// CLASS=C, TYPRUN=HOLD
// EXEC FCPTGCLG, TIME.GC=(3,0), REGION.GC=1000K
/*SETUP *****
/*MESSAGE CORE=1000K , TIME=(3,0) , MERCI
/*SETUP *****
//FCRT.SYSIN DD *

```

```

C THIS PROGRAM COMPUTES THE OPTIMAL FEEDBACK CONTROL FOR NONLINEAR
C DYNAMICAL SYSTEM. AS AN EXAMPLE, SATELLITE OPTIMAL REGULATION IS
C CONSIDERED.

```

```

COMMON/MAM/P(6,6),Q(6,3),R2(3,6),L2,XJ(6)
COMMON/DAD/UN(3),L1,U2(3),G1(3,6),U(3),D,S1
COMMON/DADJ/UJ(3),UNJ(3),U2J(3),K,NSTEP
COMMON/MAMA/AY(6504,21)
EXTERNAL FCT,OUTP,FCTJ

```

```

C DIMENSION Y(7),DERY(7),PRMT(5)
C IF L1=1 LINEAR CONTROL IS USED, IF L1=2 SECOND ORDER CONTROL IS
C USED, THE PARAMETER Z REPRESENTS THE INITIAL CONDITION.

```

```

L1=2
L2=1
L3=1
Z=2.0

```

```

C IF D>S1, REACTION JETS ARE USED OTHERWISE FLYWHEELS ARE USED.

```

```

S1=0.2
NSTEP=6504
PRMT(1)=0.0
PRMT(2)=65.0
PRMT(3)=0.01
PRMT(4)=0.0
PRMT(5)=0.0

```

```

C CALCULATIONS OF THE MATRIX RICCATI EQUATION.

```

```

DO 1 I=1,7
Y(I)=0.0
1 DERY(I)=0.0
DO 61 I=1,NSTEP
READ(1) (AY(I,J),J=1,7)
READ(1) (AY(I,J),J=8,14)
61 READ(1) (AY(I,J),J=15,21)

```

```

P(1,1)=AY(NSTEP,1)
P(1,2)=AY(NSTEP,2)
P(1,3)=AY(NSTEP,3)
P(1,4)=AY(NSTEP,4)
P(1,5)=AY(NSTEP,5)
P(1,6)=AY(NSTEP,6)
P(2,1)=P(1,2)
P(2,2)=AY(NSTEP,7)
P(2,3)=AY(NSTEP,8)
P(2,4)=AY(NSTEP,9)
P(2,5)=AY(NSTEP,10)
P(2,6)=AY(NSTEP,11)
P(3,1)=P(1,3)
P(3,2)=P(2,3)
P(3,3)=AY(NSTEP,12)
P(3,4)=AY(NSTEP,13)
P(3,5)=AY(NSTEP,14)
P(3,6)=AY(NSTEP,15)
P(4,1)=P(1,4)
P(4,2)=P(2,4)
P(4,3)=P(3,4)
P(4,4)=AY(NSTEP,16)
P(4,5)=AY(NSTEP,17)
P(4,6)=AY(NSTEP,18)
P(5,1)=P(1,5)
P(5,2)=P(2,5)

```

```

P(6,3)=P(3,5)
P(5,4)=P(4,5)
P(5,5)=AY(NSTEP,19)
P(5,6)=AY(NSTEP,20)
P(6,1)=P(1,6)
P(6,2)=P(2,6)
P(6,3)=P(3,6)
P(6,4)=P(4,6)
P(6,5)=P(5,6)
P(6,6)=AY(NSTEP,21)
DC 55 I=1,3
UJ(I)=0.0
U2J(I)=0.0
55 UNJ(I)=0.0
DC 105 I=1,3
DC 105 J=1,6
105 R2(I,J)=0.0
DC 6 I=1,3
U(I)=0.0
U2(I)=0.0
6 UN(I)=0.0
DC 8 I=1,6
9 READ(5,108) (QNI,J),J=1,3
108 FCRMAT(3F7.4)
DC 15 I=1,3
DC 15 J=1,6
XJ(J)=0.0
15 Q1(I,J)=Q(J,I)
175 N=3
MM=6
LL=6
CALL MPFD(Q1,P,R2,N,MM,LL)
F=3*(Z**2)
D=SQRT(F)
10 IF(L1.EQ.1) WRITE(6,40)
IF(L1.EQ.2) WRITE(6,50)
IF(L2.EQ.2) WRITE(6,200)
WRITE(6,60)
60 FORMAT('J',40X,'TIME VARIENT K&J ARE USED')
WRITE(6,70)
WRITE(6,80) PRMT(1),PRMT(2)
WRITE(6,90)
WRITE(6,100)
40 FORMAT('0',40X,'LINEAR FLYWHEEL CONTROLS ARE USED')
50 FORMAT('0',40X,'NO LINEAR 2ND ORDER CONTROL IS USED')
70 FORMAT('0',38X,'*****')
80 FORMAT('0',50X,'TIME FRM',2X,F6.3,2X,'TO',2X,F6.3)
90 FORMAT('0',30X,'SCLN. OF SATELLITE EQUN. WITH FLYWHEEL IS')
100 FORMAT('0',28X,'*****')
200 FORMAT('0',30X,'FLYWHEEL AND JET CONTROLS ARE USED')
HERE WE CHECK THAT IF THE DISTANCE IS GREATER THAN S1 OR NOT.
IF(L3.EQ.2) GO TO 127
136 IF(D.LE.S1) GO TO 127
IF(L1.EQ.2) GO TO 128
NDIM=4
DC 129 I=1,NDIM
DERY(I)=0.0
129 Y(I)=0.0
Y(1)=Z
Y(2)=Z
Y(3)=Z
K=0
GC TC 130
128 NDIM=4
DC 131 I=1,NDIM
DERY(I)=0.0
131 Y(I)=0.0
Y(1)=Z

```

```

Y(2)=Z
Y(3)=Z
K=0
130 CALL RKGS1(PRMT,Y,DERY,NDIM,FCTJ,CUTP,W)
127 IF(L1.EQ.2) GO TO 132
Y(7)=Y(4)
Y(5)=Y(2)
Y(6)=Y(3)
Y(4)=Y(1)
NDIM=7
Y(1)=0.0
Y(2)=0.0
Y(3)=0.0
DERY(1)=(-R2(1,4)*Y(4)-R2(1,5)*Y(5)-R2(1,6)*Y(6))*100
DERY(2)=(-R2(2,4)*Y(4)-R2(2,5)*Y(5)-R2(2,6)*Y(6))*100
DERY(3)=(-R2(3,4)*Y(4)-R2(3,5)*Y(5)-R2(3,6)*Y(6))*100
DERY(4)=0.0
DERY(5)=0.0
DERY(6)=0.0
DERY(7)=0.0
PRMT(1)=*
K=1
GO TO 134
132 Y(7)=Y(4)
Y(5)=Y(2)
Y(6)=Y(3)
Y(4)=Y(1)
NDIM=7
Y(1)=0.0
Y(2)=0.0
Y(3)=0.0
PRMT(1)=*
K=1
U(1)=(-R2(1,4)*Y(4)-R2(1,5)*Y(5)-R2(1,6)*Y(6))*100
U(2)=(-R2(2,4)*Y(4)-R2(2,5)*Y(5)-R2(2,6)*Y(6))*100
U(3)=(-R2(3,4)*Y(4)-R2(3,5)*Y(5)-R2(3,6)*Y(6))*100
CALL MFCT(Y,R2,P,DERY,XJ,Q,AA)
DERY(1)=UN(1)
DERY(2)=UN(2)
DERY(3)=UN(3)
DERY(4)=0.0
DERY(5)=0.0
DERY(6)=0.0
DERY(7)=0.0
134 CALL RKGS(PRMT,Y,DERY,NDIM,FCT,CUTP)
STOP
END
SUBROUTINE FCT(X,Y,N1,DERY,NDIM)
COMMON/MAM/P(6,6),Q(6,3),R2(3,6),L2,XJ(6)
COMMON/DAD/UN(3),L1,U2(3),C1(3,6),U(3),D,S1
COMMON/DADJ/UJ(3),UNJ(3),U2J(3),K,NSTEP
COMMON/MAMA/AY(6504,21)
DIMENSION Y(7),DERY(7),PRMT(5)
L=NSTEP-N1+1
P(1,1)=AY(L,1)
P(1,2)=AY(L,2)
P(1,3)=AY(L,3)
P(1,4)=AY(L,4)
P(1,5)=AY(L,5)
P(1,6)=AY(L,6)
P(2,1)=P(1,2)
P(2,2)=AY(L,7)
P(2,3)=AY(L,8)
P(2,4)=AY(L,9)
P(2,5)=AY(L,10)
P(2,6)=AY(L,11)
P(3,1)=P(1,3)
P(3,2)=P(2,3)

```

```
P(3,3)=AY(L,12)
P(3,4)=AY(L,13)
P(3,5)=AY(L,14)
```

```
P(3,6)=AY(L,15)
P(4,1)=P(1,4)
P(4,2)=P(2,4)
P(4,3)=P(3,4)
P(4,4)=AY(L,16)
P(4,5)=AY(L,17)
P(4,6)=AY(L,18)
P(5,1)=P(1,5)
```

```
P(5,2)=P(2,5)
P(5,3)=P(3,5)
P(5,4)=P(4,5)
P(5,5)=AY(L,19)
P(5,6)=AY(L,20)
P(6,1)=P(1,6)
P(6,2)=P(2,6)
P(6,3)=P(3,6)
```

```
P(6,4)=P(4,6)
P(6,5)=P(5,6)
P(6,6)=AY(L,21)
```

173

```
N=3
MM=6
LL=6
CALL MPRD(C1,P,R2,N,MM,LL)
F=X(4)**2+Y(5)**2+Y(6)**2
```

```
D=SQRT(F)
U(1)=(-R2(1,1)*Y(1)-R2(1,2)*Y(2)-R2(1,3)*Y(3)-R2(1,4)*Y(4)-
XR2(1,5)*Y(5)-R2(1,6)*Y(6))*100
U(2)=(-R2(2,1)*Y(1)-R2(2,2)*Y(2)-R2(2,3)*Y(3)-R2(2,4)*Y(4)-
XR2(2,5)*Y(5)-R2(2,6)*Y(6))*100
U(3)=(-R2(3,1)*Y(1)-R2(3,2)*Y(2)-R2(3,3)*Y(3)-R2(3,4)*Y(4)-
XR2(3,5)*Y(5)-R2(3,6)*Y(6))*100
IF(LL.EQ.2) GO TO 3
```

```
DERY(1)=U(1)
DERY(2)=U(2)
DERY(3)=U(3)
```

72

```
DERY(4)=-0.382*Y(5)*Y(6)+0.0003*Y(2)*Y(6)-
X 0.002*Y(3)*Y(5)-0.002*U(1)+0.000064*Y(6)
DERY(5)=0.24*Y(4)*Y(6)-0.01*Y(1)*Y(6)+0.01*Y(4)*Y(3)-
X 0.002*U(2)
DERY(6)=0.815*Y(4)*Y(5)+0.002*Y(1)*Y(5)-0.0003*
XY(2)*Y(4)-0.002*U(3)-0.00006*Y(4)
S=(Y(1)**2)+(Y(2)**2)+(Y(3)**2)+0.000001*(Y(
X 4)**2)+0.000001*(Y(5)**2)+0.000001*(Y(6)**2)
DERY(7)=(S+0.01*(U(1)**2)+0.01*(U(2)**2)+0.01*(U(3)**2))*0.00001
```

```
GO TO 4
3 CALL MFCT(Y,R2,P,DERY,XJ,Q,AA)
4 RETURN
END
```

```
SUBROUTINE MFCT(Y,R2,P,DERY,XJ,Q,AA)
COMMON/DAG/UN(3),L1,U2(3),C1(3,6),U(3),D,S1
DIMENSION Y(7),R2(3,6),P(6,6),DERY(7),XJ(6),
X AA(6,6),CR(6,6),CN(6,6),Q(6,3)
XJ(1)=0.0003*Y(3)*Y(5)+0.002*Y(3)*Y(6)-20.6*Y(5)*Y(6)-
XU.002*Y(2)*Y(6)
XJ(2)=0.0002*Y(4)*Y(4)+0.014*Y(3)*Y(4)+2.51*Y(4)*Y(6)+
XJ.0001*(Y(6)**2)-0.0022*Y(1)*Y(6)
XJ(3)=0.0003*Y(1)*Y(5)+0.014*Y(2)*Y(4)+23.23*Y(4)*Y(5)+
X0.0003*Y(5)*Y(6)
XJ(4)=0.7*Y(4)*Y(5)+0.014*Y(2)*Y(3)+0.0004*Y(2)*Y(4)+0.002*
XY(1)*Y(5)+2.5*Y(2)*Y(6)+23.23*Y(3)*Y(5)+1046.9*Y(5)*Y(6)
XJ(5)=-0.02*Y(6)*Y(6)+0.35*Y(4)*Y(4)+0.0003*Y(1)*Y(3)+0.002*
XY(1)*Y(4)-20.6*Y(1)*Y(6)+23.23*Y(3)*Y(4)+0.0003*Y(3)*Y(6)+
X1046.9*Y(4)*Y(6)
XJ(6)=0.0002*Y(2)*Y(6)-0.04*Y(5)*Y(6)-0.0022*Y(1)*Y(2)-20.6*
XY(1)*Y(5)+2.51*Y(2)*Y(4)+0.0003*Y(3)*Y(5)+1046.9*Y(4)*Y(5)
```

N=3
MM=6
LL=1

CALL MPRD(Q1,XJ,U2,N,MM,LL)

DC 20 I=1,3

20 UN(I)=U(I)-(U2(I)*50.0)

DERY(1)=UN(1)

DERY(2)=UN(2)

DERY(3)=UN(3)

2 DERY(4)=-0.882*Y(5)*Y(6)+0.0003*Y(2)*Y(6)-

X 0.002*Y(3)*Y(5)-0.002*UN(1)+0.00064*Y(6)

DERY(5)=0.24*Y(4)*Y(6)-0.01*Y(1)*Y(6)+0.01*Y(4)*Y(3)-

X 0.002*UN(2)

DERY(6)=0.815*Y(4)*Y(5)+0.002*Y(1)*Y(5)-0.0003*

X Y(2)*Y(4)-0.002*UN(3)-0.00006*Y(4)

S=(Y(1)**2)+(Y(2)**2)+(Y(3)**2)+0.000001*(Y(

X 4)**2)+0.000001*(Y(5)**2)+0.000001*(Y(6)**2)

DERY(7)=(S+0.01*(UN(1)**2)+0.01*(UN(2)**2)+0.01*(UN(3)**2))*

X 0.0003

4 RETURN

END

SUBROUTINE FCTJ(X,Y,DERY,NDIM)

COMMON/MAM/P(6,6),Q(6,3),R2(3,6),L2,XJ(6)

COMMON/DAC/UN(3),L1,U2(3),Q1(3,6),U(3),D,S1

COMMON/DADJ/UJ(3),UNJ(3),U2J(3),K

DIMENSION Y(7),DERY(7)

UJ(1)=-0.434*Y(1)+0.0377*Y(2)-0.183*Y(3)

UJ(2)=0.243*Y(1)-0.414*Y(2)-0.109*Y(3)

UJ(3)=-0.177*Y(1)-0.0163*Y(2)-0.72*Y(3)

IF(L1.EQ.2) GO TO 3

DERY(1)=-0.882*Y(2)*Y(3)+0.00006*Y(3)+0.155*UJ(1)+0.01550*Y(3)-

X 0.109*Y(2)

DERY(2)=0.24*Y(1)*Y(3)+UJ(2)-0.6*Y(3)+0.7*Y(1)

DERY(3)=0.815*Y(1)*Y(2)-0.00006*Y(1)+0.15*UJ(3)-0.015*

X Y(1)+0.09*Y(2)

S=0.1*(Y(1)**2)+0.1*(Y(2)**2)+0.1*(Y(3)**2)

DERY(4)=(S+(UJ(1)**2)+(UJ(2)**2)+(UJ(3)**2))*0.01

F=Y(1)**2+Y(2)**2+Y(3)**2

D=SQRT(F)

GO TO 4

3 U2J(1)=-1.2*(Y(1)**2)-0.004*(Y(2)**2)+0.67*Y(3)*Y(3)-

X 0.21*Y(1)*Y(2)-0.12*Y(2)*Y(3)-0.56*Y(1)*Y(3)

U2J(2)=-0.65*Y(1)*Y(1)-0.002*Y(2)*Y(2)+0.53*(Y(3)**2)-

X 0.055*Y(1)*Y(2)-0.08*Y(2)*Y(3)-0.79*Y(1)*Y(3)

U2J(3)=-0.2*Y(1)*Y(1)-0.006*Y(2)*Y(2)-0.59*(Y(3)**2)-

X 0.12*Y(1)*Y(2)+0.16*Y(2)*Y(3)+1.29*Y(1)*Y(3)

DO 8 I=1,3

3 UNJ(I)=UJ(I)+U2J(I)

DERY(1)=-0.882*Y(2)*Y(3)+0.00006*Y(3)+0.155*UNJ(1)+0.01550*Y(3)-

X 0.109*Y(2)

DERY(2)=0.24*Y(1)*Y(3)+UNJ(2)-0.6*Y(3)+0.7*Y(1)

DERY(3)=0.815*Y(1)*Y(2)-0.00006*Y(1)+0.15*UNJ(3)-0.015*

X Y(1)+0.09*Y(2)

S=0.1*(Y(1)**2)+0.1*(Y(2)**2)+0.1*(Y(3)**2)

DERY(4)=(S+(UNJ(1)**2)+(UNJ(2)**2)+(UNJ(3)**2))*0.01

F=Y(1)**2+Y(2)**2+Y(3)**2

D=SQRT(F)

4 RETURN

END

SUBROUTINE OUTP(X,Y,N1,DERY,NDIM,PRMT)

COMMON/MAM/P(6,6),Q(6,3),R2(3,6),L2,XJ(6)

COMMON/DAC/UN(3),L1,U2(3),Q1(3,6),U(3),D,S1

COMMON/DADJ/UJ(3),UNJ(3),U2J(3),K

DIMENSION Y(7),DERY(7),PRMT(5)

IF(D.GT.S1) GO TO 9

S2=SQRT(Y(1)**2+Y(2)**2+Y(3)**2)

GO TO 10

9 S2=0.0

```

10 IF(X.GT.0.0) GO TO 38
   XN=0.0
38 IF(X.LT.XN) GO TO 5
   XN=XN+0.1
   #WRITE(5,1) X
1  FORMAT('0',28X,'TIME=',F9.5)
   #WRITE(6,27)
27  FORMAT('0',20X,'*****')
   WRITE(6,2) (Y(I),I=1,4)
2  FORMAT('0',5X,4(F12.5,3X))
   WRITE(6,7) (Y(I),I=5,7),0.52,K
7  FORMAT('0',5X,5(F12.5,3X),2X,12)
   IF(0.GT.S1) GO TO 12
   IF(L1.EQ.1) WRITE(6,13) (U(I),I=1,3)
   IF(L1.EQ.2) WRITE(6,13) (UN(I),I=1,3)
   GO TO 5
12  IF(L1.EQ.1) WRITE(6,13) (UJ(I),I=1,3)
   IF(L1.EQ.2) WRITE(6,13) (UNJ(I),I=1,3)
13  FORMAT('0',5X,3(F12.5,3X))
5  RETURN
   END

```

```

      SUBROUTINE MPRD(A,B,R,N,MM,LL)
   DIMENSION A(1),B(1),R(1)
   IR=0
   IK=-MM
   DO 10 K=1,LL
     IK=IK+MM
   DO 10 J=1,N
     IR=IR+1
     JI=J-N
     IB=IK
     R(IR)=0
     DO 10 I=1,MM
       JI=JI+N
       IB=IB+1
10  R(IR)=R(IR)+A(JI)*B(IB)
   RETURN
   END

```

```

      SUBROUTINE RKGS(PRMT,Y,DERY,NDIM,FCT,OUTP)
   COMMON/DA9/JN(3),L1,U2(3),Q1(3,6),U(3),O,S1
   DIMENSION Y(7),DERY(7),R1(7),R2(7),R3(7)
1  R4(7),PRMT(5),Y2(7)
   X=PRMT(1)
   XEND=PRMT(2)
   H=PRMT(3)
   NI=1
   CALL FCT(X,Y,NI,DERY,NDIM)
   CALL OUTP(X,Y,NI,DERY,NDIM,PRMT)
1  DO 6 I=1,NDIM
6  Y2(I)=Y(I)
   H=PRMT(3)
2  DO 2 I=1,NDIM
   R1(I)=H*DERY(I)
   Y(I)=Y2(I)+0.5*R1(I)
   X1=X+0.5*H
   CALL FCT(X1,Y,NI,DERY,NDIM)
   DO 3 I=1,NDIM
3  R2(I)=H*DERY(I)
   Y(I)=Y2(I)+0.5*R2(I)
   CALL FCT(X1,Y,NI,DERY,NDIM)
   DO 4 I=1,NDIM
4  R3(I)=H*DERY(I)
   Y(I)=Y2(I)+R3(I)
   X1=X+H
   CALL FCT(X1,Y,NI,DERY,NDIM)
   DO 5 I=1,NDIM
5  R4(I)=H*DERY(I)
   R=(R1(I)+2.0*R2(I)+2.0*R3(I)+R4(I))/6.0

```

```

5      Y(I)=Y2(I)+R
      X=X+H
      NI=NI+1
-----
17     CALL OUTP(X,Y,NI,DERY,NDIM,PRMT)
      IF(X.LE.XEND) GO TO 1
      RETURN
      END
      SUBROUTINE RKGS1(PRMT,Y,DERY,NDIM,FCTJ,OUTP,W)
      COMMON/DAC/UN(3),L1,U2(3),C1(3,6),U(3),D,S1
      DIMENSION Y(7),DERY(7),R1(7),R2(7),R3(7),
1      R4(7),PRMT(5),Y2(7)
      X=PRMT(1)
      XEND=PRMT(2)
      H=PRMT(3)
      CALL FCTJ(X,Y,DERY,NDIM)
      CALL OUTP(X,Y,NI,DERY,NDIM,PRMT)
2      DO 6 I=1,NDIM
      Y2(I)=Y(I)
      H=PRMT(3)
      DO 2 I=1,NDIM
      R1(I)=H*DERY(I)
      Y(I)=Y2(I)+0.5*R1(I)
      X1=X+0.5*H
      CALL FCTJ(X1,Y,DERY,NDIM)
      DO 3 I=1,NDIM
      R2(I)=H*DERY(I)
      Y(I)=Y2(I)+0.5*R2(I)
3      CALL FCTJ(X1,Y,DERY,NDIM)
      DO 4 I=1,NDIM
      R3(I)=H*DERY(I)
      Y(I)=Y2(I)+R3(I)
4      X1=X+H
      CALL FCTJ(X1,Y,DERY,NDIM)
      DO 5 I=1,NDIM
      R4(I)=H*DERY(I)
      P=(R1(I)+2.0*R2(I)+2.0*R3(I)+R4(I))/6.0
5      Y(I)=Y2(I)+R
      X=X+H
      W=X
      CALL OUTP(X,Y,NI,DERY,NDIM,PRMT)
      IF(D.LE.S1) GO TO 17
      IF(X.LT.XEND) GO TO 1
17     RETURN
      END
-----
//GC.SY$IN DD *
1.0000 0.0000 0.0000
0.0000 1.0000 0.0000
0.0000 0.0000 1.0000
-0.0020 0.0000 0.0000
0.0000-0.0020 0.0000
0.0000 0.0000-0.0020
-----
//GC.FTDIF001 DD UNIT=DISK,VOL=SER=USER10,DISP=OLD,
// DSN=$SD.TOA,DATA9,
// DCB=(RECFM=VBS,LRECL=12004,BLKSIZE=12009)
/*

```