



## NOTICE

The quality of this microfiche is heavily dependent upon the quality of the original thesis submitted for microfilming. Every effort has been made to ensure the highest quality of reproduction possible.

If pages are missing, contact the university which granted the degree.

Some pages may have indistinct print especially if the original pages were typed with a poor typewriter ribbon or if the university sent us a poor photocopy.

Previously copyrighted materials (journal articles, published tests, etc.) are not filmed.

Reproduction in full or in part of this film is governed by the Canadian Copyright Act, R.S.C. 1970, c. C-30. Please read the authorization forms which accompany this thesis.

THIS DISSERTATION  
HAS BEEN MICROFILMED  
EXACTLY AS RECEIVED

## AVIS

La qualité de cette microfiche dépend grandement de la qualité de la thèse soumise au microfilmage. Nous avons tout fait pour assurer une qualité supérieure de reproduction.

S'il manque des pages, veuillez communiquer avec l'université qui a conféré le grade.

La qualité d'impression de certaines pages peut laisser à désirer, surtout si les pages originales ont été dactylographiées à l'aide d'un ruban usé ou si l'université nous a fait parvenir une photocopie de mauvaise qualité.

Les documents qui font déjà l'objet d'un droit d'auteur (articles de revue, examens publiés, etc.) ne sont pas microfilmés.

La reproduction, même partielle, de ce microfilm est soumise à la Loi canadienne sur le droit d'auteur, SRC 1970, c. C-30. Veuillez prendre connaissance des formules d'autorisation qui accompagnent cette thèse.

LA THÈSE A ÉTÉ  
MICROFILMÉE TELLE QUE  
NOUS L'AVONS REÇUE

ORGANIC SULFUR CHEMISTRY

- I. EPOXY SULFONES
- II. OXIDATION OF SULFUR-STABILIZED CARBANIONS
- III.  $\alpha$ -LITHIO SULFONES

by

John Michael Decesare

Thesis submitted to the School of Graduate  
Studies in partial fulfillment for the  
requirements for the degree of Ph.D. in  
Chemistry

University of Ottawa  
Ottawa, Ontario

John Michael Decesare, 1979

## I

ABSTRACTSPART IEpoxy Sulfones

$\gamma$  and  $\delta$ -Epoxy sulfones have been shown to undergo cyclization to 3-phenylsulfonycycloalkanols upon treatment with 2 equivalents of  $\text{CH}_3\text{MgI}$ . It was found that the resultant cycloalkanols are formed in a highly stereospecific manner with the phenylsulfonyl and hydroxyl groups occupying a cis relationship to each other. This stereochemistry was determined by an x-ray structure determination on 3-phenyl-3-phenylsulfonycyclobutanol. The cyclization reaction was found to require 2 equivalents of Grignard reagent.

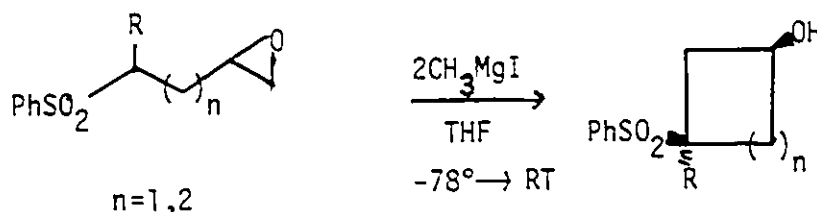

The parent cycloalkanols ( $\text{R}=\text{H}$ ) could be readily substituted in the 3-position by treatment with 2 equivalents of methyllithium followed by trapping with various electrophiles.

The 3-alkyl-3-phenylsulfonycycloalkanols could be readily converted into cyclobutenones and cyclopent-2-enones by treatment with Jones

reagent and then triethylamine.

The 3-phenylsulfonylcyclobutanol was readily desulfonylated by treatment with 6% Na(Hg) amalgam.

Several mechanistic aspects of the Grignard induced epoxy sulfone cyclization were also investigated.

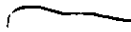

### III

#### PART II

##### Oxidation of Sulfur-Stabilized Carbanions

The oxidation of  $\alpha$ -lithio sulfur-stabilized carbanions was attempted with several types of reagents. Oxidation of  $\alpha$ -lithio benzhydryl phenyl sulfone was found to proceed smoothly upon treatment with  $O_2$  or  $S_8$ . The reaction with  $S_8$  may constitute a potential method for the synthesis of diaryl thioketones. Attempts to affect the desired oxidation of other sulfur-stabilized carbanions failed.

IV

PART III

$\alpha$ -Lithio Sulfones

The  $\alpha$ -carbanion of 2,6-diphenylthiane-1,1-dioxide was shown to react with electrophiles in a stereospecific manner with incorporation of the electrophiles ( $H_2O$ ,  $D_2O$ ,  $CH_3I$ ) in the equatorial position of the ring. Attempts to obtain information concerning the structure of  $\alpha$ -lithio sulfonyl carbanions by  $^1H$  or  $^{13}C$  NMR were not successful due to either decomposition of the sample or poor resolution of the spectra.

ACKNOWLEDGEMENTS

I would like to thank the following :

Professor T. Durst for his guidance, extreme patience and enthusiasm throughout my studies;

Other members of the staff, especially Dr. Fraser and Dr. Alper for helpful suggestions and valuable advice;

Margie Glinski for the tedious task of proofreading;

Trudy Jones for the typing of the thesis;

My wife Dorothy for her encouragement.

## VI

TABLE OF CONTENTS

	Page
ABSTRACTS.....	I
ACKNOWLEDGEMENTS.....	V
TABLE OF CONTENTS.....	VI
LIST OF TABLES.....	VIII
LIST OF SCHEMES.....	IX
ABBREVIATIONS.....	XI
<u>PART I</u> EPOXY SULFONES.....	1
Introduction.....	2
Results and Discussion.....	26
Preparation of Epoxy Sulfones.....	31
Base Induced Cyclizations.....	41
Synthesis of Non-Sulfur Containing Derivatives.....	59
Attempted Cyclopropene Synthesis.....	74
Stereochemistry and Mechanism.....	78
Conclusions Regarding Epoxy Sulfone Cyclization.....	93
Grignard Induced Cyclization of Epoxy Nitriles and Epoxy Phosphine Oxides.....	95
<u>PART II</u> OXIDATION OF SULFUR-STABILIZED CARBANIONS.....	99
Introduction.....	100
Results and Discussion.....	108
Conclusions.....	114

VII

	Page
<u>PART III</u> $\alpha$ -LITHIO SULFONES.....	116
Introduction.....	117
Synthesis of Starting Materials.....	118
Results and Discussion.....	121
Conclusions.....	125
$^1\text{H}$ and $^{13}\text{C}$ NMR of $\alpha$ -Sulfonyl Carbanions.....	126
<u>EXPERIMENTAL</u> .....	129
<u>PART I</u> .....	131
<u>PART II</u> .....	<del>188</del>
<u>PART III</u> .....	190
<u>REFERENCES</u>	
<u>PART I</u> .....	201
<u>PART II</u> .....	205
<u>PART III</u> .....	207
<u>CLAIMS TO ORIGINAL RESEARCH</u> .....	208

## VIII

LIST OF TABLESTABLE

Page

PART I

I. Cyclization of $\delta$ -Epoxy Ketones and Esters.....	16
II. Base Induced Cyclization of $\gamma$ -Epoxy Sulfones.....	28
III. Alkylation of 3-Phenylsulfonyl Cycloalkanols.....	64
IV. Conversion of 3-Phenylsulfonyl Cycloalkanols into 3-Substituted Cyclobutenones and Cyclopent-2-enones.....	67
V. Synthetic Scope of Epoxy Sulfone Cyclization.....	69
VI. Base Requirement of Epoxy Sulfone Cyclization.....	91

PART III

I. $^{13}\text{C}$ NMR Data for <u>Cis</u> and <u>Trans</u> -2,6-Diphenylthiane-1,1-Dioxide.	122
--	-----

LIST OF SCHEMES

Scheme

Page

PART I

1. Mechanism for the Formation of 3-Phenylsulfonylcyclobutanol from the Grignard Induced Cyclization of 3-Phenylsulfonyl-1,2-epoxybutane.....	29
2. Synthesis of 5-Phenylsulfonyl-but-1-ene.....	31
3. Synthesis of 5-Phenylsulfonyl-1,2-epoxypentane.....	33
4. Synthesis of Aldehydes <u>64</u> and <u>65</u> .....	36
5. Synthesis of Epoxy Sulfones <u>69</u> and <u>70</u> .....	37
6. Stereochemical Course of $\gamma$ -Epoxy Sulfone Cyclization.....	43
7. "One-Pot" Preparation of Cyclobutanols and Cyclopentanols....	46
8. Mechanism for the "One-Pot" Preparation of 3-Phenylsulfonyl cyclobutanols.....	48
9. Mechanism for the "One-Pot" Preparation of 3-Phenylsulfonyl cyclopentanols.....	49
10. Mechanism for the Formation of 2-Phenyl-3-Phenylsulfonyl cyclopentanol.....	53
11. $\alpha$ , $\beta$ - Unsaturated Ketones from $\beta$ -Keto Sulfones.....	60
12. Alkylation of 3-Phenylsulfonylcycloalkanols.....	63
13. Potential Synthesis of 2,3-Disubstituted Cyclopentenones.....	68
14. Synthesis of Cyclobutenone.....	70

Scheme	Page
15. Synthesis of 2,2-Dimethylcyclobutenone.....	72
16. Mechanism for the Formation of 3-Phenylsulfonyl cyclobutanol.....	78
17. Mechanism for the Conversion of $\gamma$ -Epoxy Sulfones into Cyclopropyl Methanols.....	93
<u>PART II</u>	
1. Conversion of Nitriles into Ketones.....	103
<u>PART III</u>	
1. Synthesis of 4-t-butylthiane-1,1-dioxide.....	120
2. Reaction of $\alpha$ -Lithio Sultone Carbanions with Electrophiles	124

ABBREVIATIONS

IR - infrared

NMR -  $^1\text{H}$  nuclear magnetic resonance

$^{13}\text{C}$  NMR -  $^{13}\text{C}$  nuclear magnetic resonance

TLC - thin layer chromatography

THF - tetrahydrofuran

MCPBA - m-chloroperbenzoic acid

MeLi - methyllithium

M.S. - mass spectrum

$\text{M}^+$  - parent molecular ion

$\text{LiAlH}_4$  - lithium aluminum hydride

TEBA - triethylbenzylammonium chloride

LDA - lithium diisopropyl amide

DMSO - dimethylsulfoxide

PART I  
EPOXY SULFONES

### INTRODUCTION

The intermolecular reaction of epoxides with nucleophiles has been extensively studied, both from a synthetic and a mechanistic point of view (1-3).

The intramolecular reaction, which has received far less attention, has been shown to be synthetically useful in the construction of various ring systems. The reaction of interest can be generalized as depicted below.

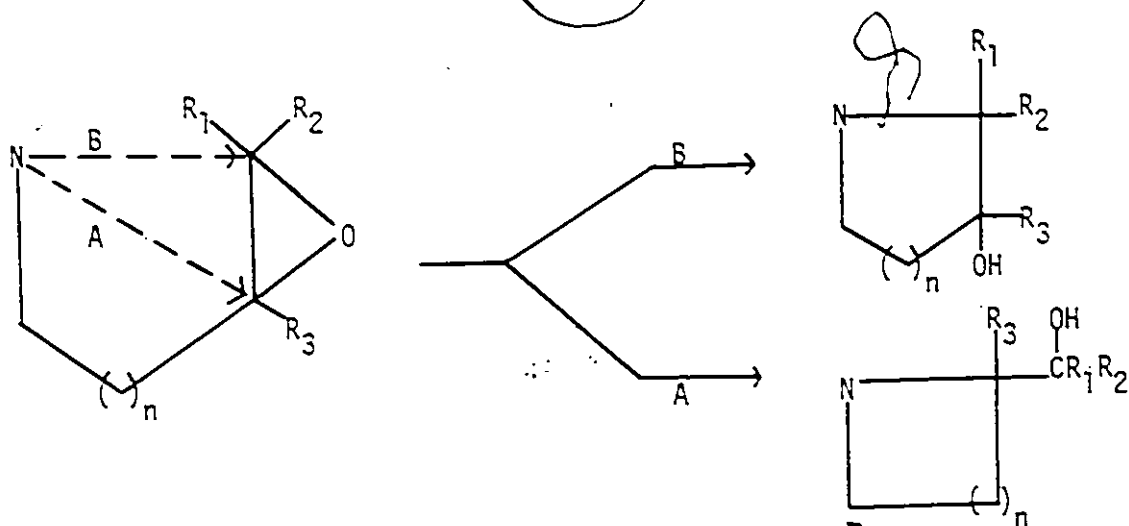

Two modes of attack by the internal nucleophile (N) on the epoxide ring may be envisaged. One, involving attack at the near end of the epoxide may be termed exo-cyclization (PATH A) and the other, involving attack at the more remote position of the epoxide (PATH B), endo-cyclization. It is instructive to examine the stereoelectronic requirements of both these ring forming processes.

Exo-Cyclization: (PATH A)

This process corresponds closely to the Baldwin (4) exo-tetrahedral and exo-trigonal ring forming cyclizations, both of which are favoured processes for the ring sizes 3 to 7.

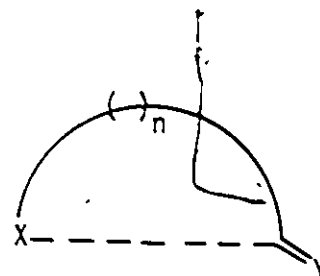
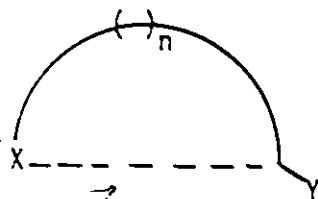

Opening of an epoxide ring may be considered to be intermediate between these two ring closures and no problem is encountered in satisfying the stereoelectronic demands for the exo-transition state. The required colinearity between the incoming nucleophile and the oxirane oxygen is easily attained for  $n=2,3,4,5,6$ .

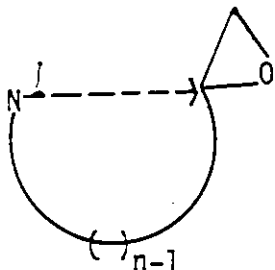

The relative ease of ring closure is thus expected to follow the well established trend of  $3 > 5 > 6 > 7, 4$ . (5)

Endo-Cyclization (PATH B)

In this mode of opening of the epoxide the colinearity requirement is not as easily met. For example, closure of the epoxide 1 requires considerable bond distortion in order to attain the proper geometry for backside attack. Formation of a six-membered ring 2 via this pathway seems to be more feasible. Formation of a four-membered ring from epoxide 3 is not possible.

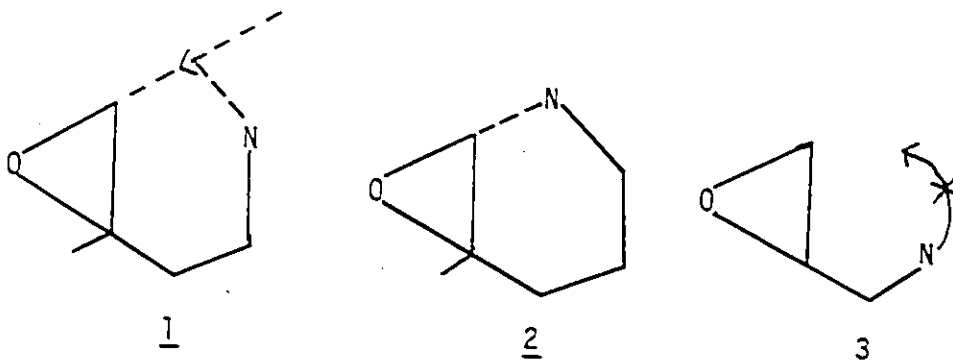

The importance of this colinearity requirement was first demonstrated by Eschenmoser (6). He reported that under all conditions studied methyl transfer of 4 to 5 proceeds intermolecularly. This was ascribed to the difficulty of effecting backside displacement by the anion 6. Intramolecular transfer would have required an  $S_N2$  substitution at the methyl carbon with retention of configuration.

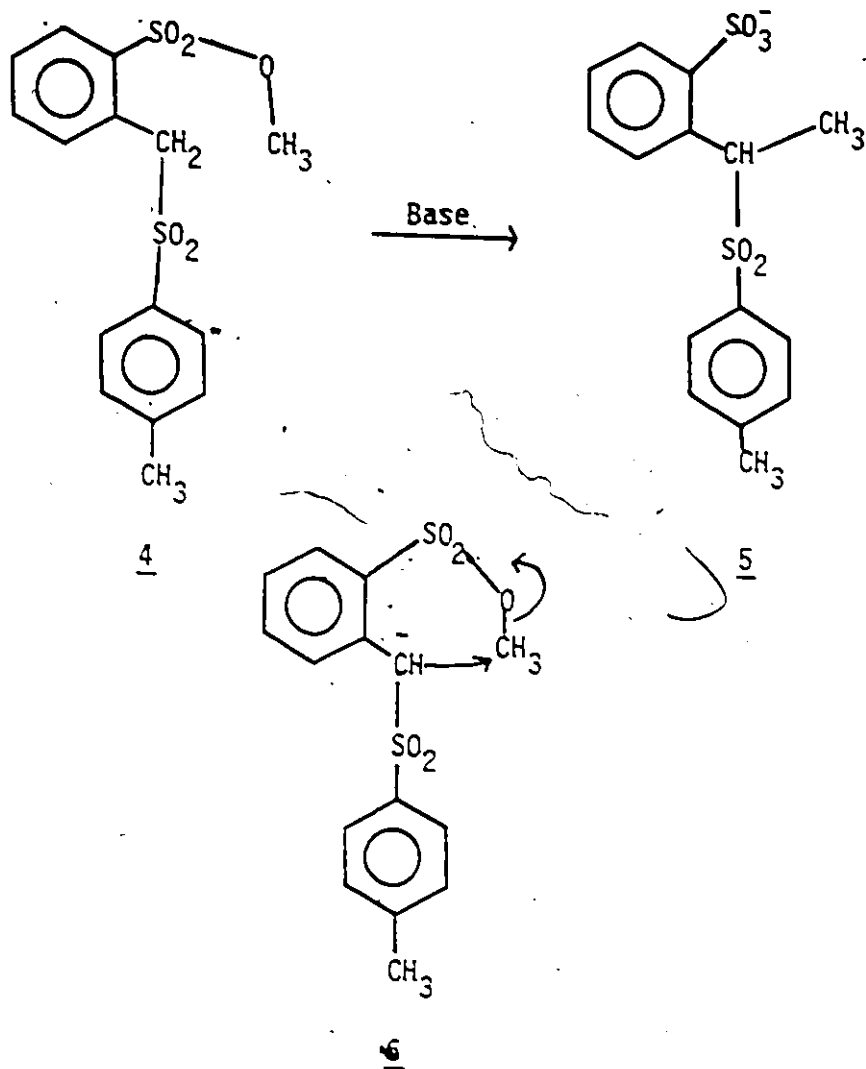

The exo mode of cyclization would be predicted, a priori, to be the preferred pathway, however, other factors need to be considered such as epoxide stereochemistry, relative degree of substitution on the epoxide, nature of the nucleophile and solvent effects.

These will be illustrated by examination of the relevant literature in this field. Reactions will be classified according to the nature of the nucleophile.

(i) Stabilized Carbanion Nucleophiles

(ii) Heteroatom Nucleophiles

(i) Stabilized Carbanion Nucleophiles

Epoxy Nitriles

The major impetus for the development of the intramolecular epoxide cyclization\* reaction as an important synthetic tool came from the work reported by Stork and coworkers (7,8). These authors showed that the regiochemistry of the reaction is controlled both by the substitution pattern of the epoxide and the colinearity requirement. Thus, they found that treatment of rigid epoxides of type 7 with one equivalent of potassium amide in liquid ammonia-glyme resulted in attack of the carbanion at the more remote position of the epoxide ring leading to formation of the hydroxy nitriles 8. The cis ring junction follows from the mode of ring opening.

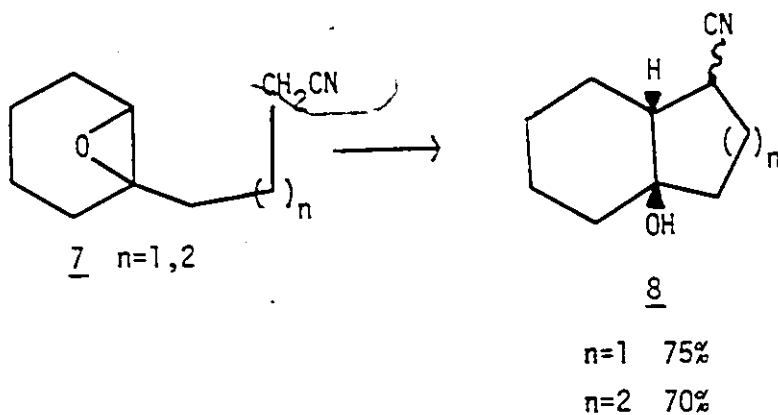

\* intramolecular epoxide cyclization will be used to refer to formation of a cycle via intramolecular attack of a nucleophile on an epoxide.

The preference for the formation of the larger ring was ascribed to the steric constraints imposed on the system with attack at the quaternary centre being less favourable than that at a tertiary carbon. It was also noted that the six-membered ring was formed considerably faster than the five-membered ring (2 hr. vs 7 min.). This was rationalized in terms of the aforementioned colinearity requirement, i.e. easier attainment of colinearity in the formation of a six membered ring via endo attack.

With equal substitution on the epoxide ring exo attack was found to be preferred as is shown in the conversion of 9 to 10.

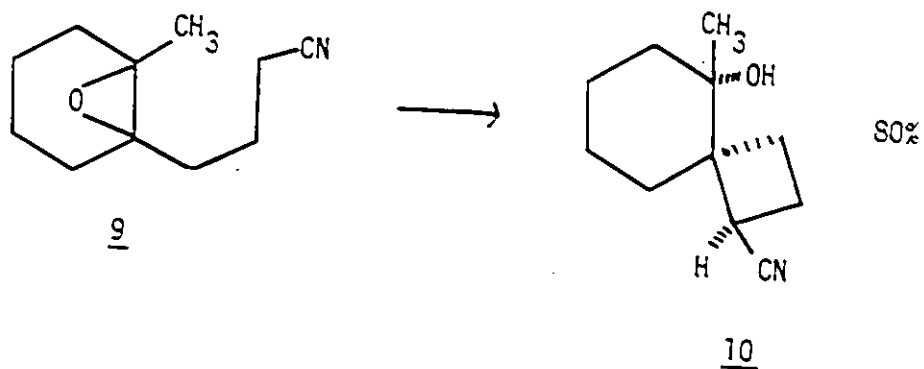

Stork also studied the cyclization of non-rigid epoxy nitriles. The overall results are presented below.

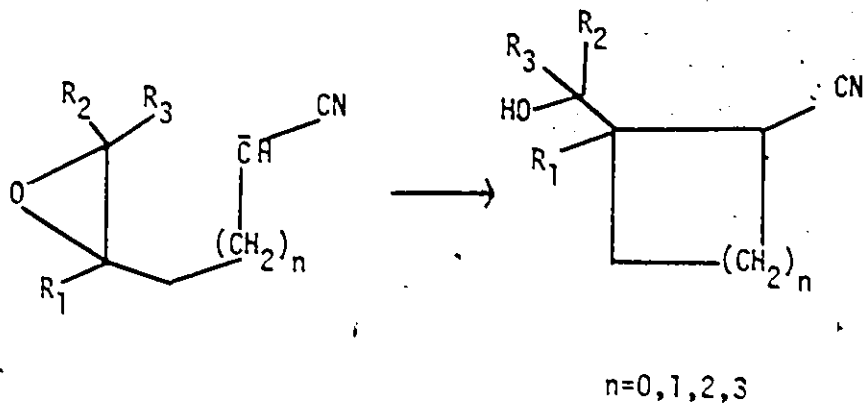

$R_1, R_2=H ; R_3=\text{alkyl}$

$R_1=H ; R_2, R_3=\text{alkyl}$

$R_1, R_2, R_3=\text{alkyl}$

In the case of  $n=0$ , cyclopropanes are formed exclusively, regardless of the degree of substitution on the epoxide ring. This is not surprising since endo attack to form a four membered ring is most unlikely ( $n=1,2,3$ ). Stork came to the conclusion that with equal substitution on the epoxide ring the smaller ring is always formed preferentially (exo attack). The case of ( $n=1$ ) merits special attention since this constitutes a non-photochemical synthesis of four-membered rings.

The use of an epoxide cyclization reaction to form a four membered ring had been previously reported (9) in the synthesis of the tricyclo-octane system 11.

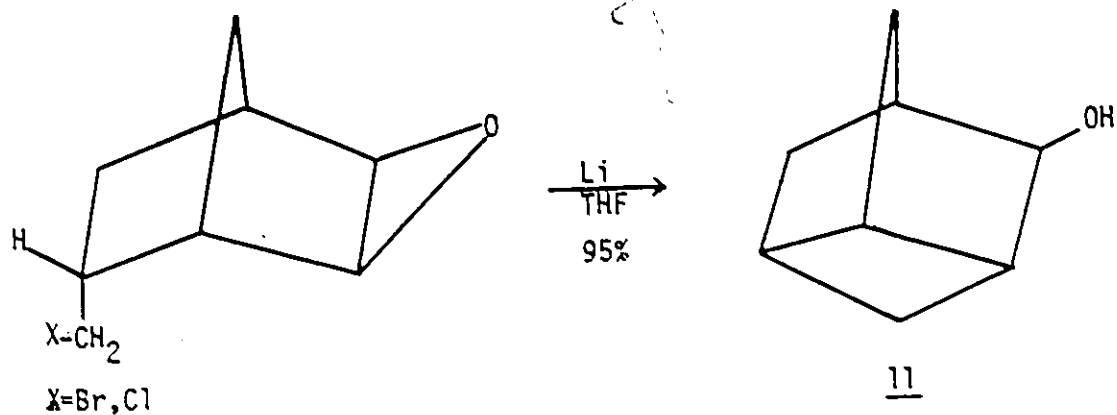

Stork demonstrated the utility of the epoxy nitrile cyclization by a synthesis of the sex pheromone (+) grandisol **14**. The key step was cyclization of the epoxy nitrile **12** to the trans-cyclobutane derivative **13**.

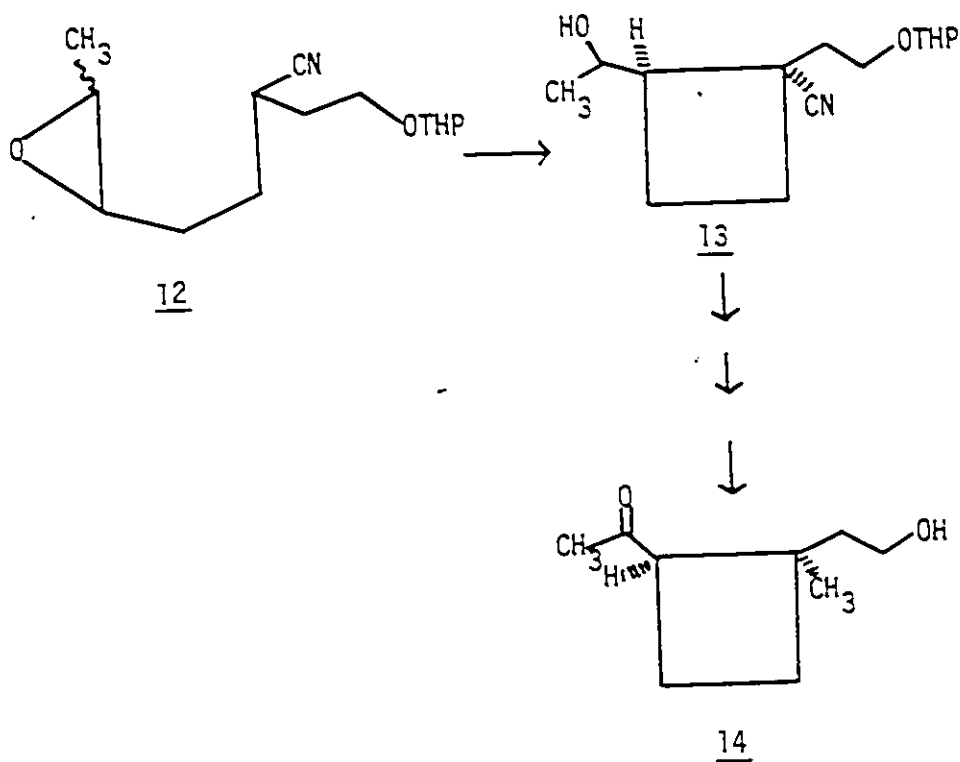

Stork's conclusions regarding epoxy nitrile cyclizations were later challenged by Lallemand and Onanga (10). These authors concluded that the stereochemistry about the epoxide ring is the important factor in controlling the regiochemistry in epoxy nitrile cyclizations. Thus, they reported that treatment of the cis epoxide 15 with sodamide in THF gave only the cyclobutane derivative 16.

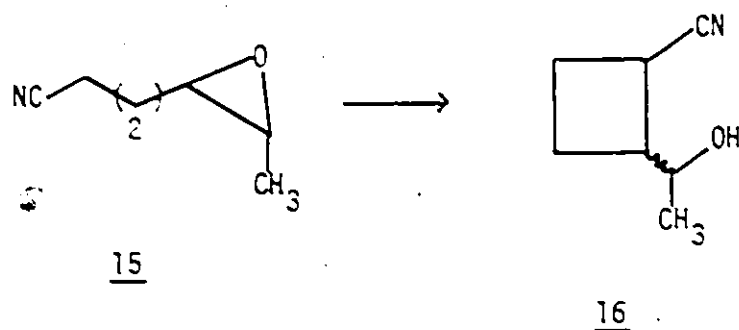

In contrast, reaction of the trans epoxide 17 under identical conditions, resulted in the formation of both four and five-membered ring products 16 and 18 with the five-membered ring predominating in an approximately 2:1 ratio.

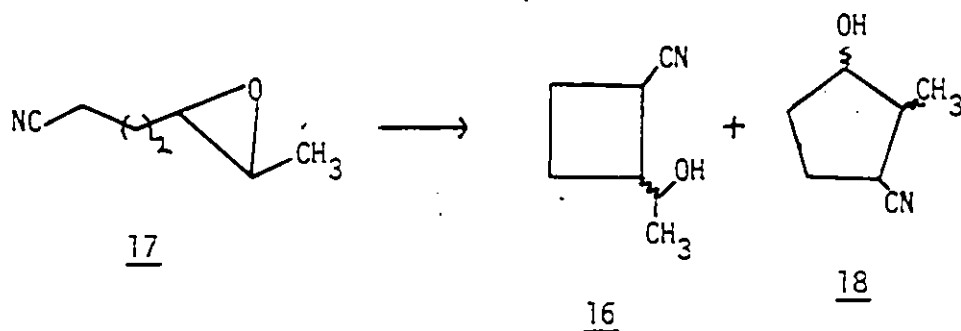

The authors suggested that these results can be explained on steric grounds. In the case of the cis epoxide 15 attack at C-5 is hindered by the presence of the methyl group, whereas in the case of the trans epoxide 17 no steric hinderance to attack is present. The observed product distribution from the reaction of the trans epoxide 17 was suggested to arise from a combination of "statistical and geometric factors".

An examination of molecular models suggests that a similar amount of steric shielding is present in both the cis and trans epoxides with respect to attack at C-5. The Lallemand and Onanga results thus appear difficult to rationalize and a closer scrutiny of the role of epoxide stereochemistry in the reaction appears justified.

Other workers have made use of the epoxy nitrile cyclization reaction in synthesis. For example, Achini and Oppolzer (11) showed that treatment of epoxy aminonitriles 19 with potassium amide in liquid ammonia-ether for 1 hr. at  $-60^{\circ}\text{C}$  lead to formation of the pyrrolidine derivatives 20 in yields of 63-67%.

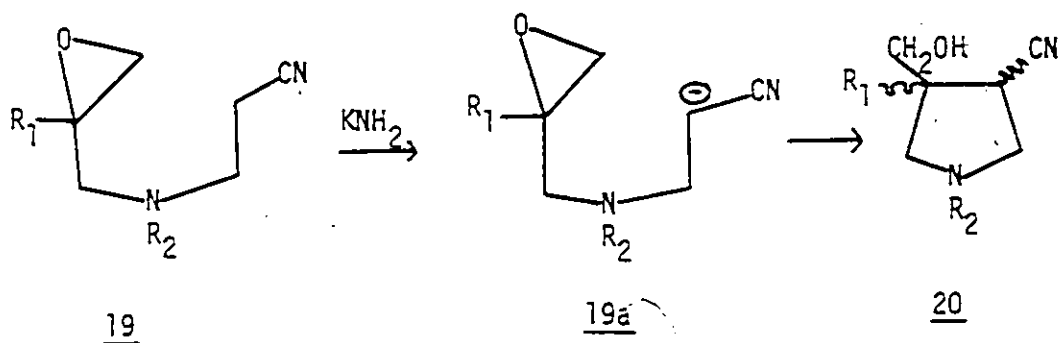

Attack of the nitrile-stabilized carbanions 19a was found to occur exclusively at the more substituted carbon atoms of the epoxide rings. This is in contrast to Stork's observations that similarly substituted epoxy nitriles give six-membered rings preferentially. The possibility of participation of the nitrogen atom in the above systems could be considered.

### Epoxy Sulfides

Intramolecular cyclization of epoxy sulfides has been shown to be useful in the synthesis of medium ring and macrocyclic terpenoids. Thus, Kodama et al (12) reported that reaction of the epoxy sulfide 21 with *n*-butyllithium at  $-78^{\circ}$ , in the presence of DABCO, leads to the monocyclic alcohol 22a in 62% yield. Desulfurization of 22a with lithium-ethylamine afforded the fourteen-membered ring diterpene (+) nephtenol 22b in 30% yield. Dehydration of 22b with thionyl chloride in pyridine furnished the tetraene 23 in 95% yield.

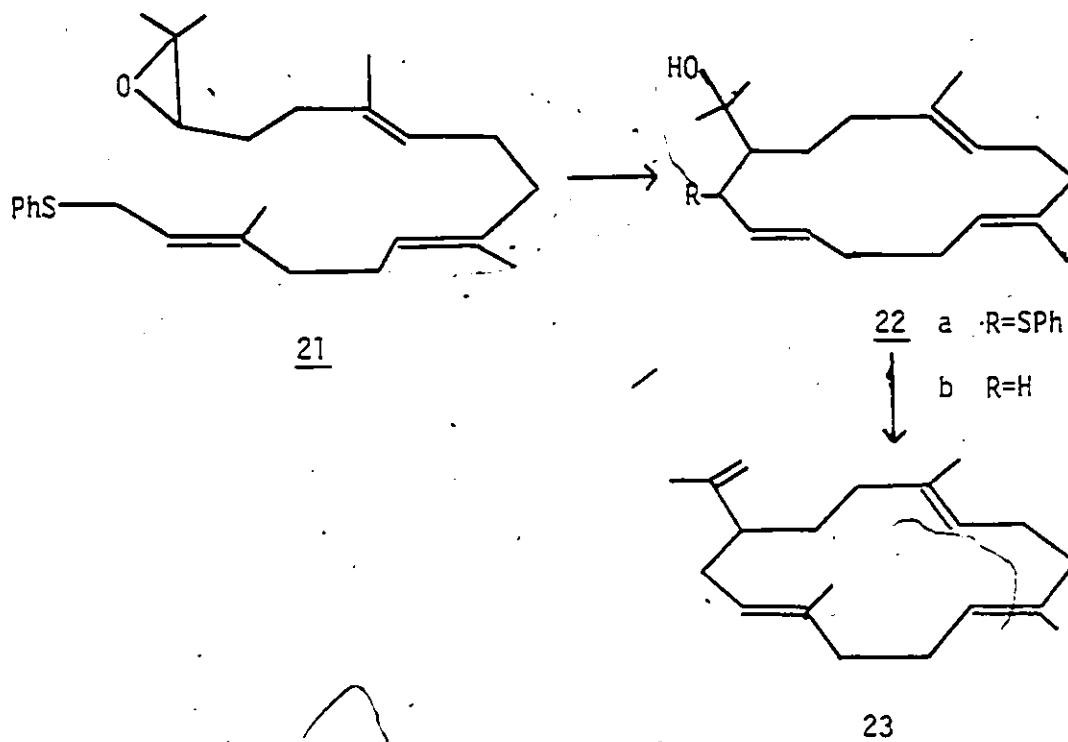

Such an approach has also been used in the synthesis of the 6E (13) and 6Z (14) isomers of hedycaryols.

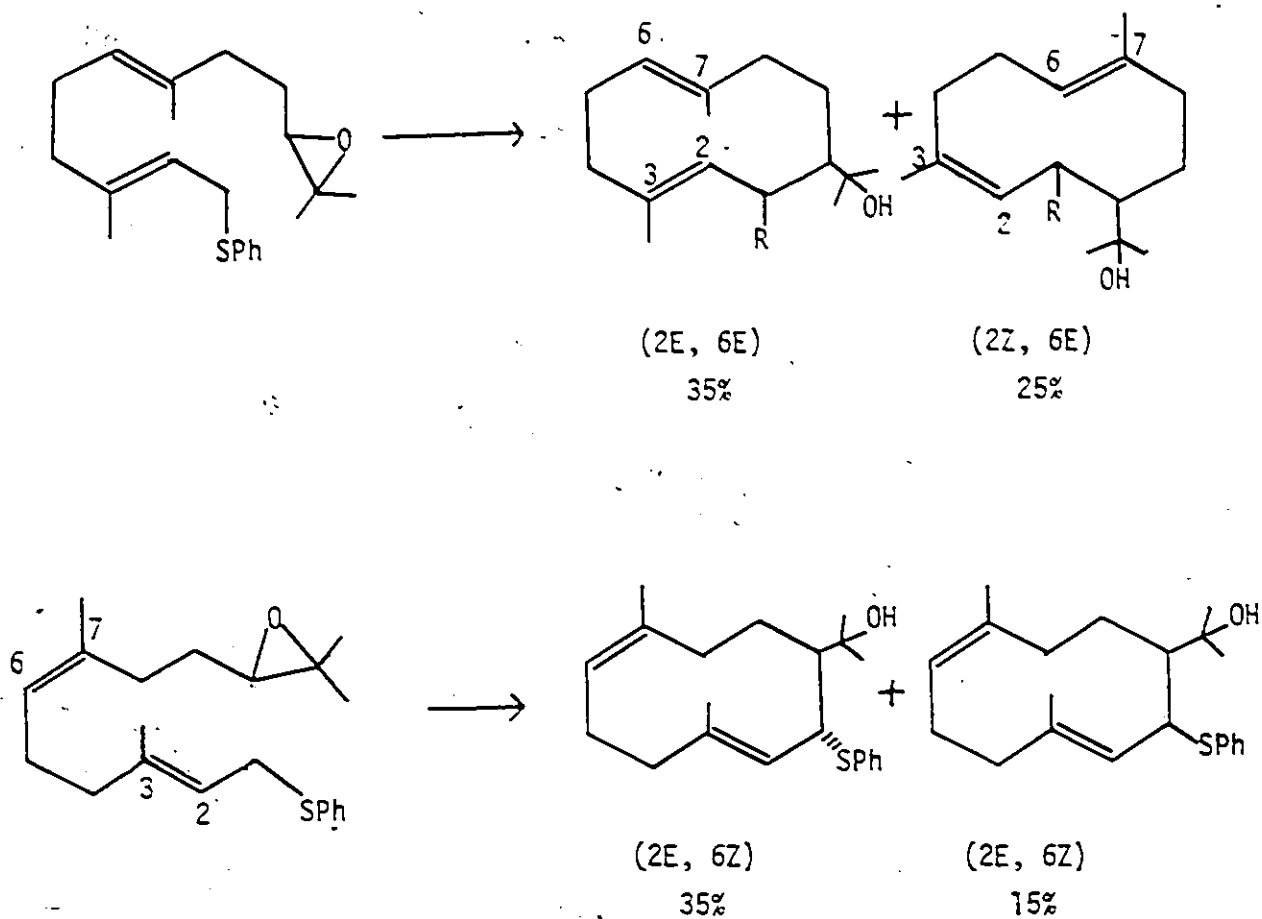

In another study by Rautenstrauch,(15) reaction of the geranyl derivative 24 with butyllithium in THF resulted in the formation of a complex mixture of products in 65% overall yield. The reaction exhibited neither regio- or stereoselectivity.

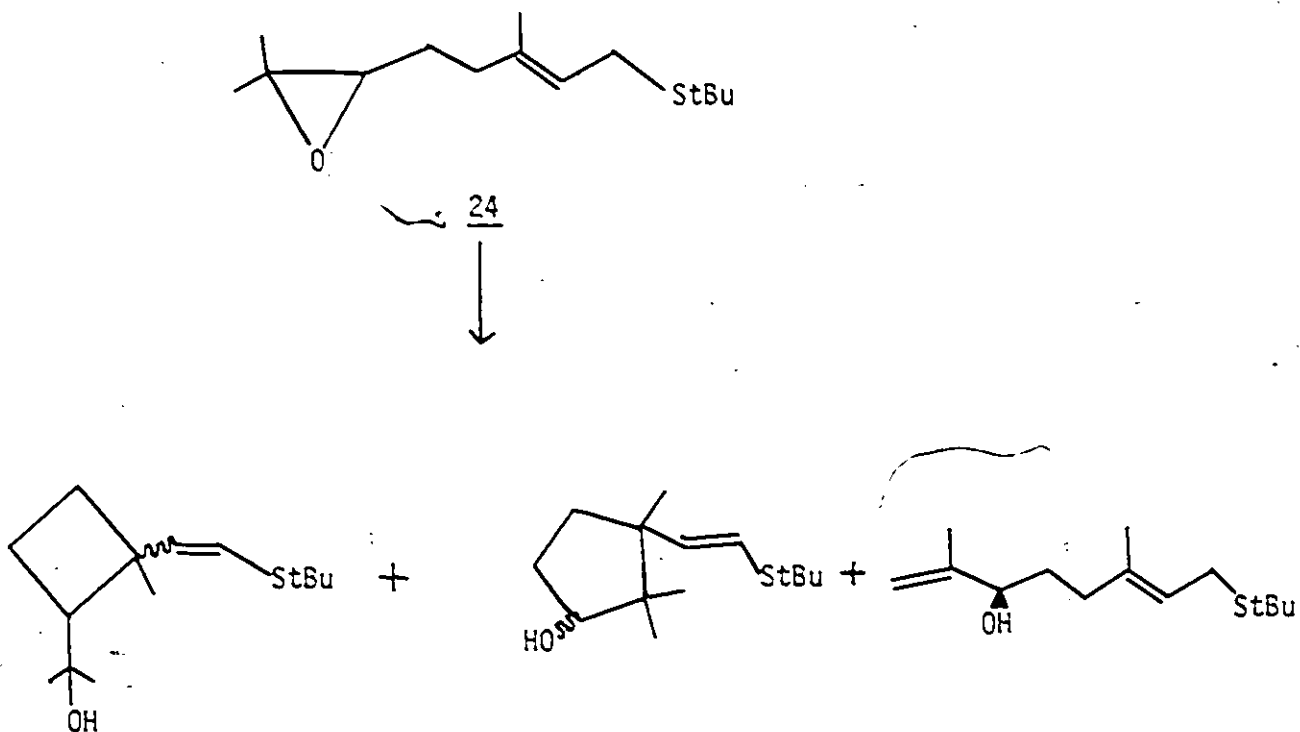

### Epoxy Ketones and Esters

The reaction of  $\gamma$ -epoxy ketones with bases (NaOH, KOtBu) yields invariably, via C-alkylation, the corresponding cyclopropyl derivatives (16). O-alkylation leading to the dihydrofuran and pyran derivative is not competitive with cyclopropane ring formation.

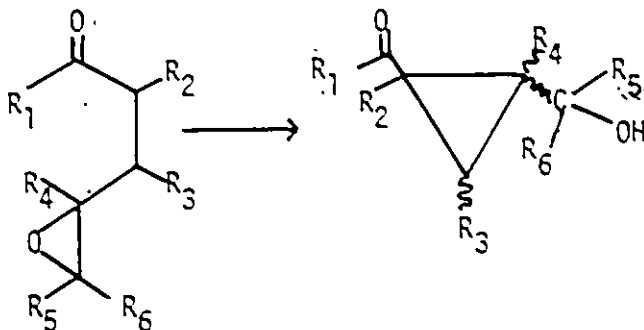

The corresponding  $\gamma$ -epoxy esters were found to behave similarly.

The reaction products from  $\delta$ -epoxy diesters or keto esters under basic conditions were found to depend markedly on the nature of the substituents which stabilized the carbanion (17,18). These results are summarized in Table I.

TABLE I

Cyclization of  $\delta$ -Epoxy Ketones and Esters

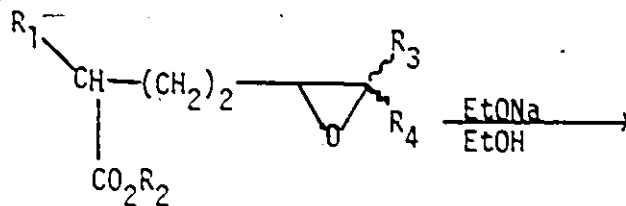

$R_1$	$R_2$	$R_3$	$R_4$	Product
$CO_2CH_3$	$CH_3$	$CH_3$	$CH_3$	No Reaction
$CO_2Et$	Et	H	H	
$C_6H_5CO$	Et	H	H	
$CH_3CO$	$CH_3$	$CH_3$	$CH_3$	

Epoxy ketones have found application in the synthesis of the sabinone 25 (19) and the norcarone 26 (20).

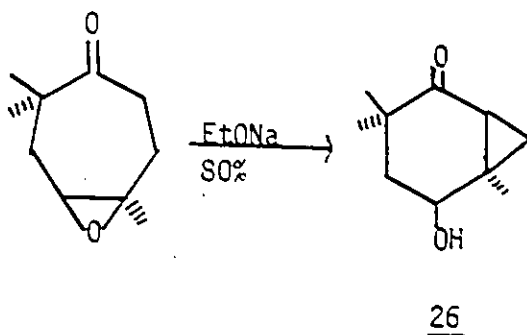
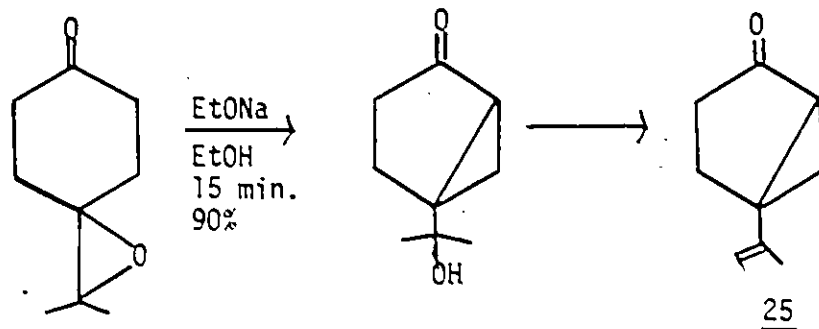

More remote cyclizations have also been shown to be possible. For example, Hodgson *et al* (21) reported that treatment of the epoxy ketone 27 with potassium *t*-butoxide/*t*-butanol resulted in an 80% yield of the tricyclic system 28.

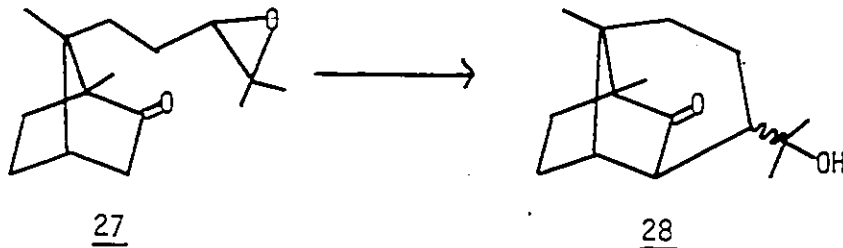

The key step in one approach (22) to the total synthesis of trans-chrysanthemic acid 31 was the base-promoted cyclization of the epoxy ester 29 furnishing the trans-cyclopropane 30.

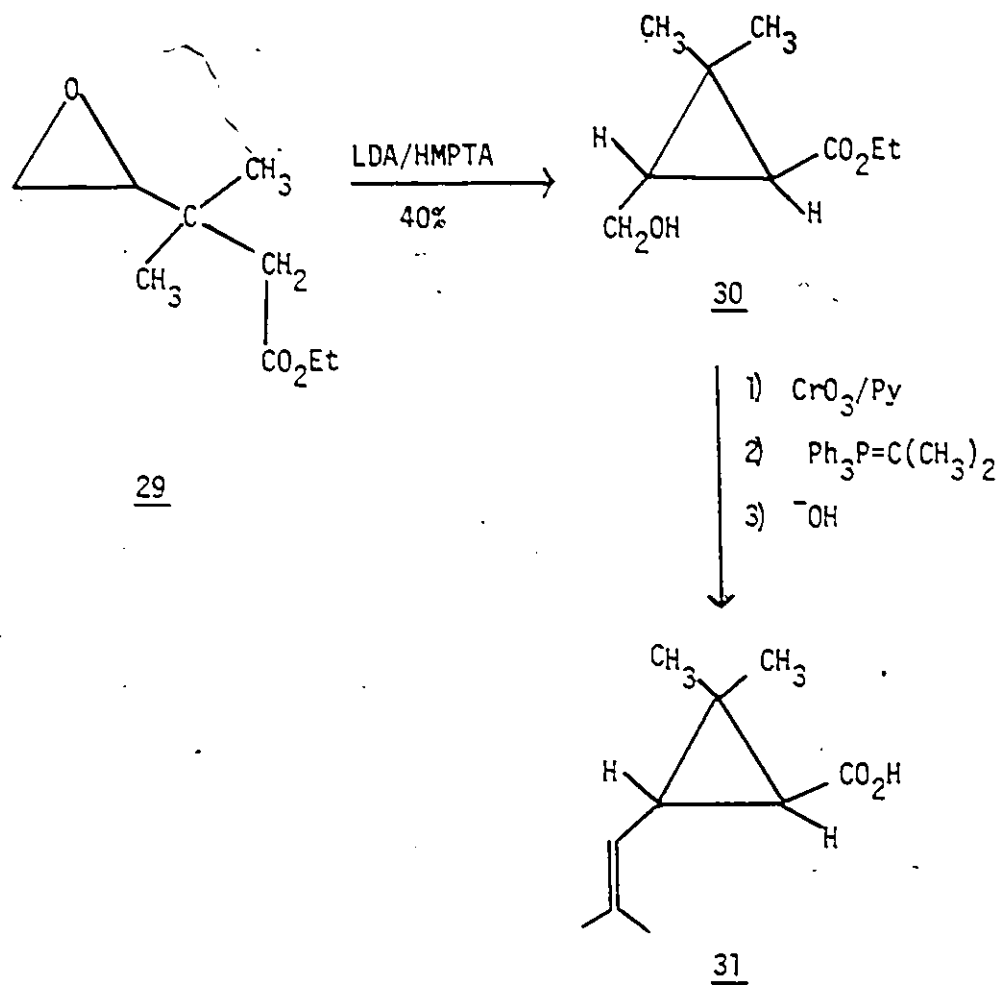

### Epoxy Phosphonium Ylides

In 1977 Turcant and Le Carre (23) reported the first examples of the involvement of phosphorus stabilized anions in an epoxide cyclization reaction. These authors studied the cyclization of epoxy phosphonium ylides of type 32.

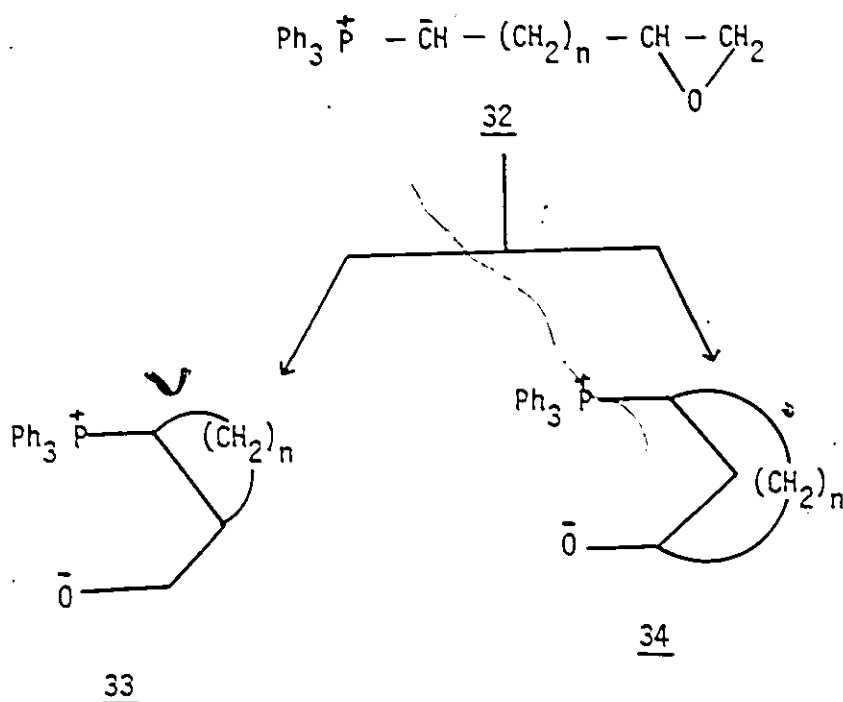

Two types of cyclization products, 33 and 34 were observed. The results obtained by these authors are presented below.

Cyclization of Epoxy Phosphonium Ylides 32

<u>n</u>	<u>Relative Yields</u>		<u>Total Yields</u>
	<u>33</u>	<u>34</u>	<u>33</u> + <u>34</u>
1	100	0	90
2	20	80	56
3	60	40	43
4	0	100	54

As expected, when  $n=1$  the cyclopropane derivative is the only product. The other cases ( $n=2,3,4$ ) seem anomalous. Particularly unusual is the exclusive formation of the seven-membered ring vs the six membered ring when  $n=4$ . In general, it appears that attack at the unsubstituted terminal carbon is preferred possibly due to steric hindrance involving the large triphenylphosphonium group.

(ii) Heteroatom Nucleophiles

Epoxy Mercaptans

Johnson *et al* (24) reported that cyclization of the epoxy mercaptide 35 furnished 2-thianorbornan-6-ol 36 in 23% yield.

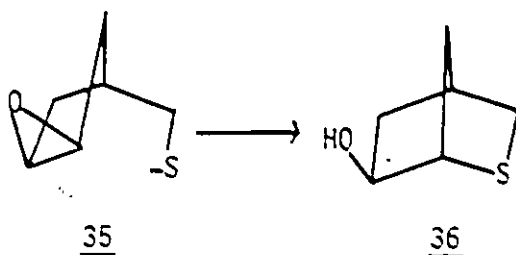

Epoxy Amides

Synthesis of the azaadamantol system 39 was effected by ring closure of the epoxy amide 37 to the amide alcohol 38 which was subsequently reduced with diborane in THF (25).

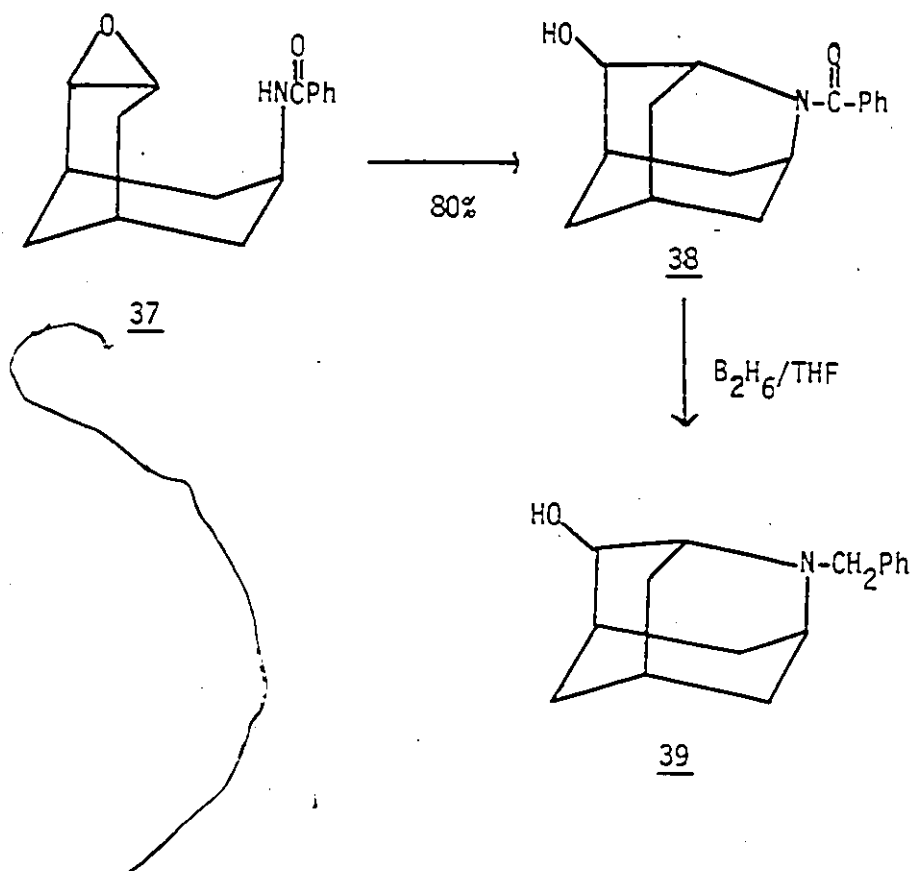

### Epoxy Alcohols

Epoxy alcohols have received considerable attention in many diverse areas. Thus, Spurlock and Fayter (26) obtained 2-oxa-norboran-6-ol 41 via potassium t-butoxide promoted ring closure of the epoxy alcohol 40.

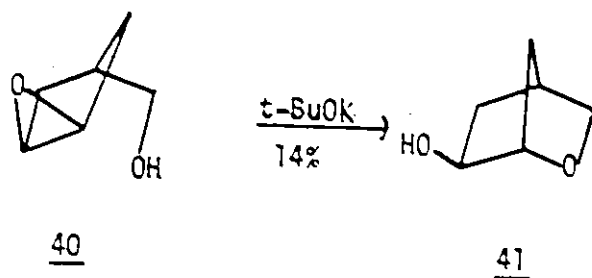

The carbohydrate literature is replete with examples of the opening of an oxirane ring by an appropriately situated hydroxyl group (27). Migrations of the epoxide ring in systems of type 42 are well known.

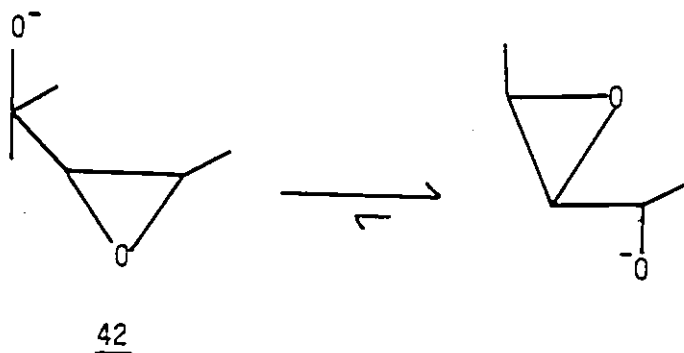

Many examples of more remote cyclizations are available.

For example, reaction of the D-galactoside 43 with base afforded the D-gulopyranoside 44.

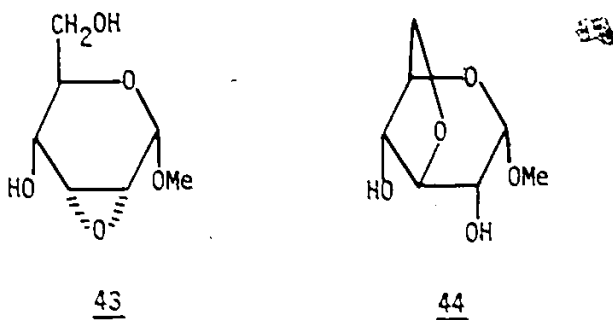

Another area of investigation was the synthesis (28) of the chromanol derivative 47. The formation of 47 by reaction of 45 with dimethylsulfonium methylide presumably occurs through the intermediacy of the epoxy alkoxide 46.

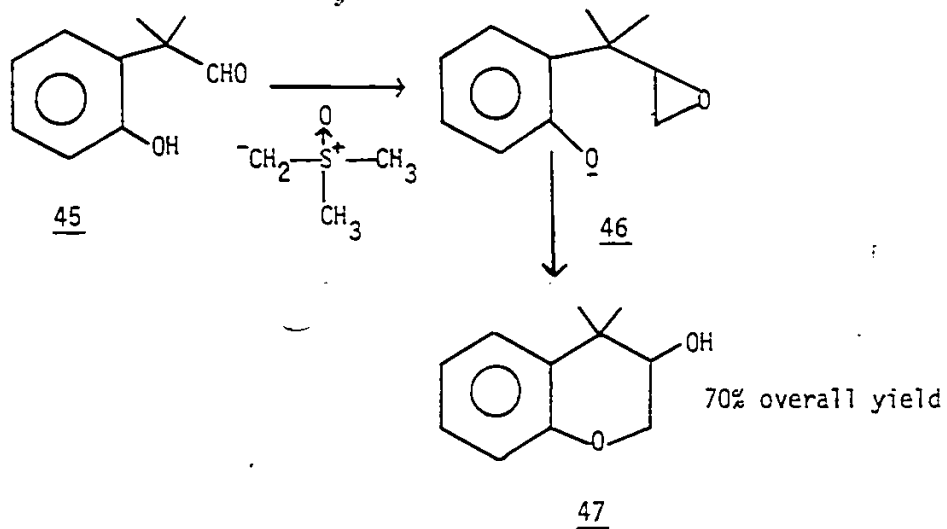

Masamune et al (29) reported that epoxy alcohols of the type 48 react with ten equivalents of KOH in aqueous DMSO to furnish the oxetane derivatives 49 as the sole cyclization products. No five-membered ring products were observed.

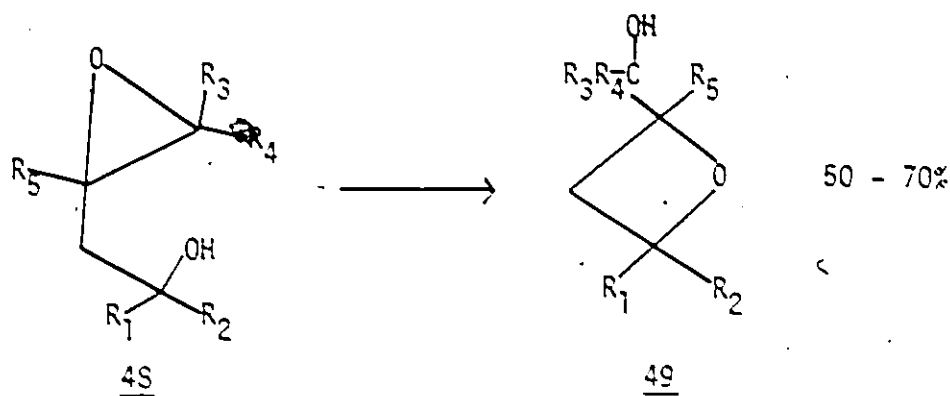

These authors (30) also examined the influence of epoxide stereochemistry on the regiochemistry of the epoxy alcohol cyclization reaction. They reported that treatment of either the cis or trans derivative of 50 (a and b) gave essentially the same result, namely, formation of the oxetane derivative 51.

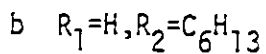
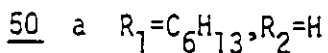
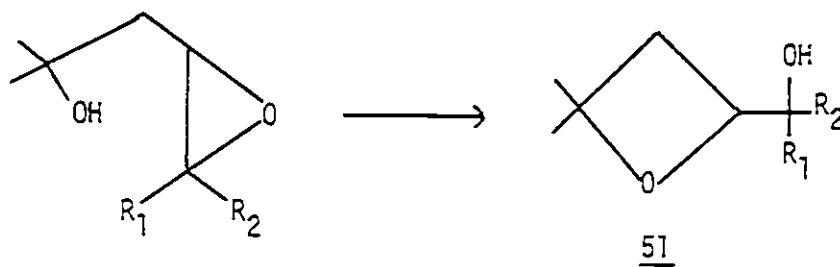

These results are in contrast to those of Lallemant and Onanga (10) who showed that in epoxy nitrile cyclizations the epoxide stereochemistry was a dominant factor in governing the regiochemistry of the cyclization. However, the two reaction systems differ widely (ie. solvent, base, nucleophile) and strict comparison may not be justified.

## Results and Discussion

### Introduction

The first example of the base-promoted cyclization of epoxy sulfones was reported by Gaoni (31). Thus, he found that treatment of  $\gamma$ -epoxy sulfones with *n*-butyllithium in hexane at  $-15^\circ$  yielded the trans-1- arylsulfonyl-2- (hydroxyalkyl) cyclopropanes in yields of 80-95%.

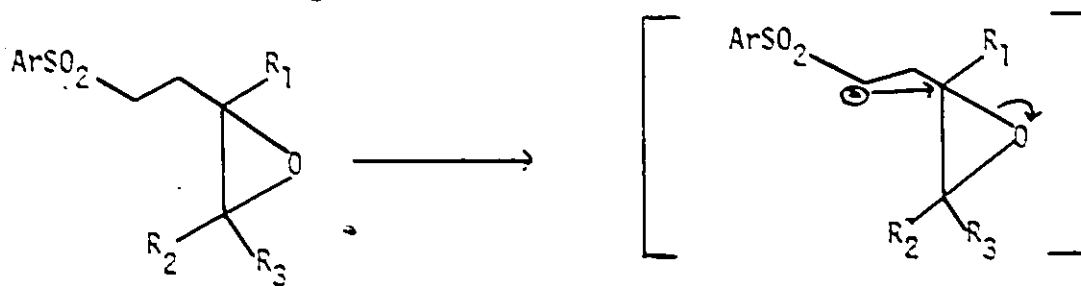

- Ar = *p*-tolyl, C<sub>6</sub>H<sub>5</sub>
- R<sub>1</sub> = H, CH<sub>3</sub>
- R<sub>2</sub> = H, CH<sub>3</sub>, (CH<sub>2</sub>)<sub>4</sub>
- R<sub>3</sub> = H, CH<sub>3</sub>, (CH<sub>2</sub>)<sub>4</sub>, CH (CH<sub>3</sub>)<sub>2</sub>

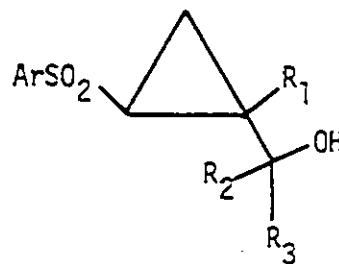

The exclusive formation of cyclopropyl derivatives is in agreement with Stork's (8) observation of cyclopropane formation in the  $\gamma$ -epoxy nitrile series and both sets of results may be interpreted in terms of the colinearity requirement (4).

The cyclization of  $\gamma$ -epoxy sulfones was also studied by Corbel and Durst (32). These authors also observed that the reaction of  $\gamma$ -epoxy sulfones with LDA furnished cyclopropane derivatives, in agreement with Gaoni's observations. However, additionally they found that the ring size of the product can be altered from three to four by changing the base from LDA (or  $\text{CH}_3\text{Li}$ ) to  $\text{CH}_3\text{MgI}$ .

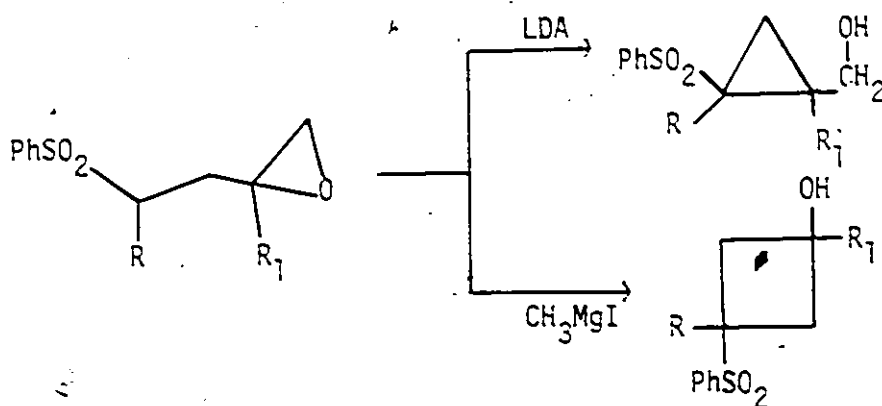

Cyclobutanol formation with the Grignard reagent as base was observed only in the case of terminally unsubstituted  $\gamma$ -epoxy sulfones. In contrast the 1,2-disubstituted epoxides gave only cyclopropylmethanol derivatives irrespective of the base employed. These results are summarized in Table II.

TABLE II  
Base Induced Cyclization of  $\gamma$ -Epoxy Sulfones

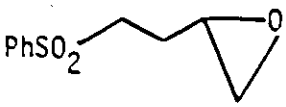
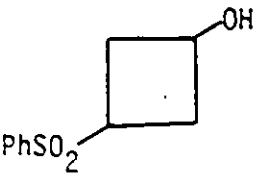
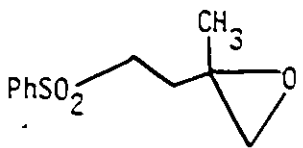
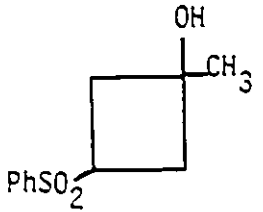
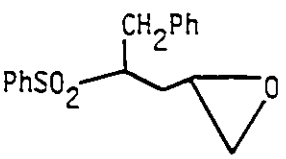
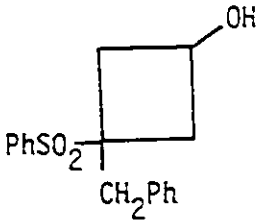
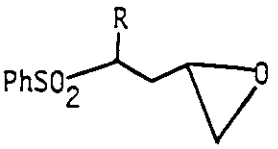
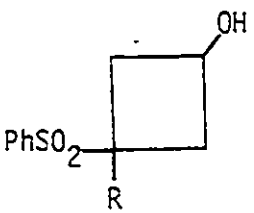
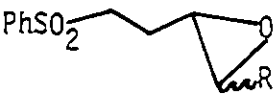
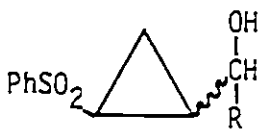
Epoxy Sulfone	Product	Base	Yield
		$\text{CH}_3\text{MgI}$	90
		$\text{CH}_3\text{MgI}$	51
		$\text{CH}_3\text{MgI}$	89
		$\text{CH}_3\text{MgI}$	92 R=C <sub>4</sub> H <sub>9</sub> 95 R=C <sub>6</sub> H <sub>13</sub>
R=C <sub>4</sub> H <sub>9</sub> , C <sub>6</sub> H <sub>13</sub>			
		$\text{CH}_3\text{MgI}$	70 R=Ph 35 R=CH <sub>3</sub>
R=Ph, CH <sub>3</sub>		LDA	98 R=Ph 71 R=CH <sub>3</sub>

Corbel and Durst briefly studied the mechanism of the cyclobutanol formation. Their proposed mechanism (Scheme 1) involves initial opening of the epoxide to generate the iodoalkoxide in a regiospecific manner. This is followed by formation of the  $\alpha$ -sulfonyl carbanion which subsequently cyclizes to the cyclobutanol. Support for the mechanism was obtained by isolating the halohydrin after quenching the reaction mixture at low temperature and showing that this substance was converted to the cyclized product by treatment with two equivalent of  $\text{CH}_3\text{MgI}$ .

Scheme 1

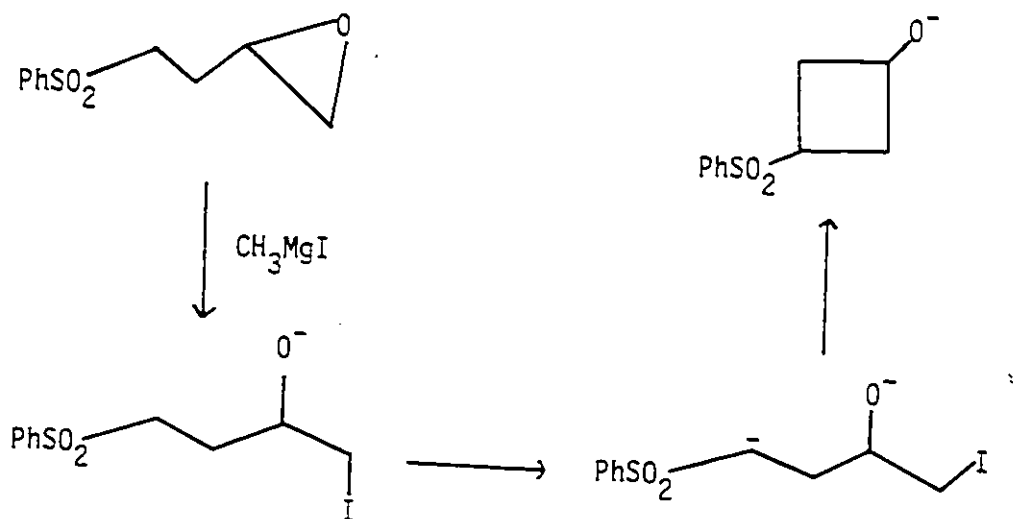

The 3-phenylsulfonyl cyclobutanols obtained above were converted into 3-substituted cyclobutenones in 80-95% overall yield.

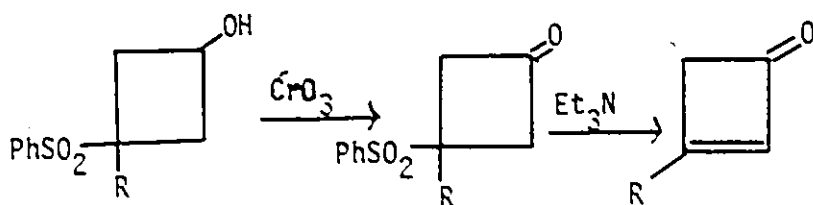

$\text{R} = \text{Ph}, \text{C}_4\text{H}_9, \text{C}_6\text{H}_{13}$

Due to the interest in epoxides as useful synthetic intermediates, (33) a more extensive study, both from the synthetic and mechanistic points of view, of the epoxy sulfone reaction seemed warranted.

### Preparation of Epoxy Sulfones

The epoxy sulfones required for this study were prepared by relatively standard procedures. The routes chosen for the individual epoxides are described below.

#### $\gamma$ -Epoxy Sulfones

A key intermediate in the preparation of a variety of  $\gamma$ -epoxy sulfones was the unsaturated sulfone 53. This substance, NMR  $\delta$ : 2.1-2.6 (m, 2H), 2.9-3.3 (m, 2H), 4.7-6.0 (m, 3H) and 7.3-7.9 (m, 5H), was prepared in two steps from thiophenol and 4-bromo-1-butene (Scheme 2).

Scheme 2

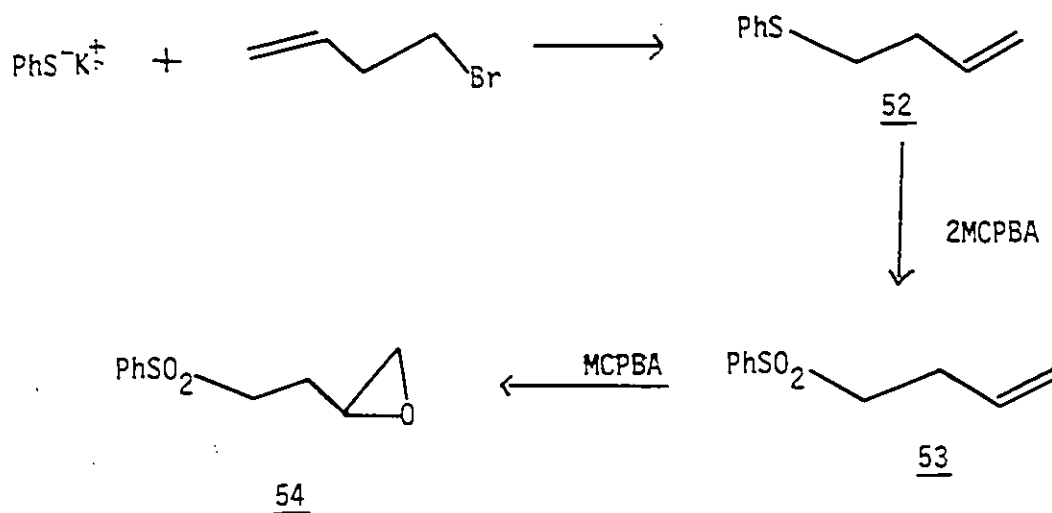

Thus, the reaction of phenylthiolate with 4-bromo-1-butene furnished the olefin 52, NMR  $\delta$ : 2.1-2.6 (m, 2H), 2.8-3.2 (m, 2H), 4.9-6.3 (m, 3H), and 7.1-7.5 (m, 5H), in 90% yield. Careful oxidation of 52 at room temperature with two equivalents of MCPBA provided the sulfone 53 in 85% yield after chromatography. Because of the difference in the rates of oxidation of the sulfide to the sulfone vs epoxidation of the olefinic bond, no problems were encountered in stopping the reaction at the olefin sulfone 53 stage.

Epoxidation of 53 with one equivalent of MCPBA in refluxing methylene chloride overnight yielded the epoxy sulfone 54 in 95% yield. The structure of 54 was confirmed by the absence of olefinic hydrogens in the NMR and appearance of the characteristic epoxide multiplets in the  $\delta$  2.4-3.3 region.

Epoxy sulfones bearing alkyl substituents  $\alpha$  to the sulfonyl grouping were readily obtained by first alkylating 53 via its  $\alpha$ -sulfonyl carbanion followed by epoxidation with MCPBA. The structure of these compounds were established on the basis of their spectroscopic properties and the method of synthesis. (see Experimental Section)

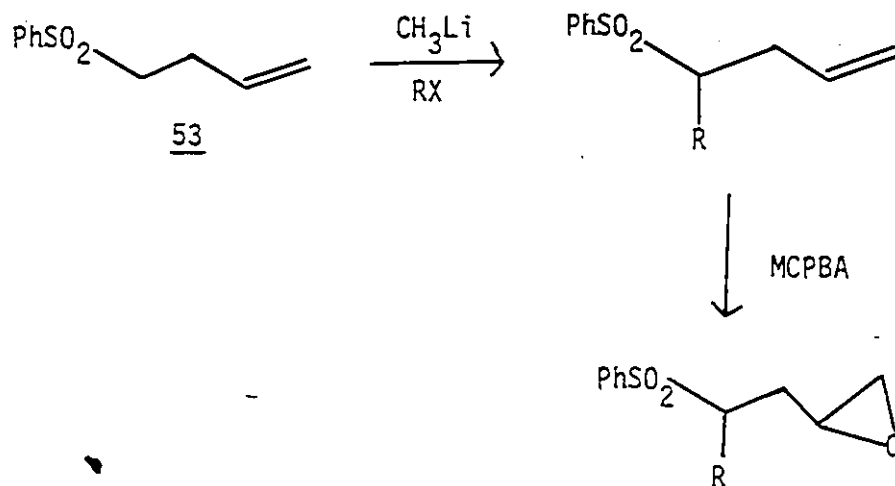

(ii)  $\delta$ -Epoxy Sulfones

The important intermediate, 1-phenylsulfonylpent-4-ene 57.  
NMR  $\delta$ : 1.4-2.4 (m, 4H), 2.9-3.2 (m, 2H), 4.7-5.9 (m, 3H), and 7.2-7.9  
(m, 5H), required in the synthesis of  $\delta$ -epoxy sulfones was prepared  
as shown in Scheme 3.

Scheme 3

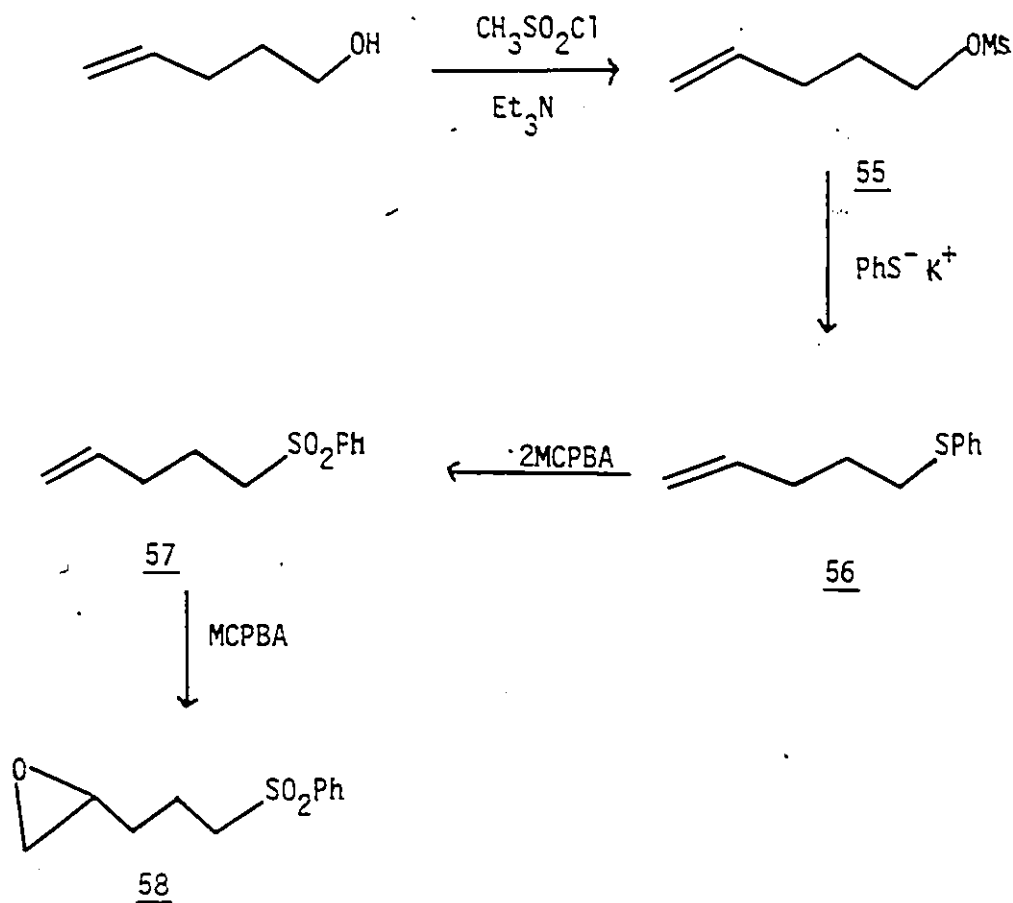

Commercially available 4-penten-1-ol was mesylated with methanesulfonyl chloride providing 55 in 96% yield: NMR  $\delta$ : 1.5-2.3 (m, 4H), 2.9 (s, 3H), 4.15 (t,  $J=6\text{Hz}$ , 2H), 4.7-6.0 (m, 3H). Reaction of the mesylate 55 with potassium phenylthiolate in methanol afforded the olefin 56, NMR  $\delta$ : 1.4-2.4 (m, 4H), 2.79 (t,  $J=7\text{Hz}$ , 2H), 4.7-6.0 (m, 3H), 7.0-7.4 (m, 5H), in 97% yield. Oxidation of 56 with two equivalents of MCPBA gave 57 in 66% yield. Further treatment of 57 with one equivalent of MCPBA provided the parent  $\delta$ -epoxy sulfone 58 in 90% yield. This compound was also more efficiently obtained (90% isolated yield) by the one-pot oxidation and epoxidation of 56 with three equivalents of MCPBA. The structure of the epoxy sulfone 58 was supported by the NMR data.  $\delta$ : 1.2-2.2 (m, 4H), 2.4-4.3 (m, 5H), 7.3-8.1 (m, 5H).

The 1-benzyl derivative 60 which was required was prepared by treating 57 with *n*-butyllithium at  $-70^\circ$  and then quenching with benzyl bromide. This provided a 64% yield of the benzyl derivative 59. NMR  $\delta$ : 1.5-2.3 (m, 4H), 2.5-3.5 (m, 3H), 4.6-5.7 (m, 3H), 7.0-8.0 (m, 5H); IR 1140 and 1300  $\text{cm}^{-1}$ , ( $\text{SO}_2$ ), 1640 ( $\text{C}=\text{C}$ ). Epoxidation of 59 with MCPBA furnished the epoxy sulfone 60 in 95% yield. NMR peaks for 60 occurred at  $\delta$ : 1.3-3.5 (m, 10H) and 6.9-7.9 (m, 10H) and the IR spectrum showed no terminal  $\text{C}=\text{C}$  stretch.

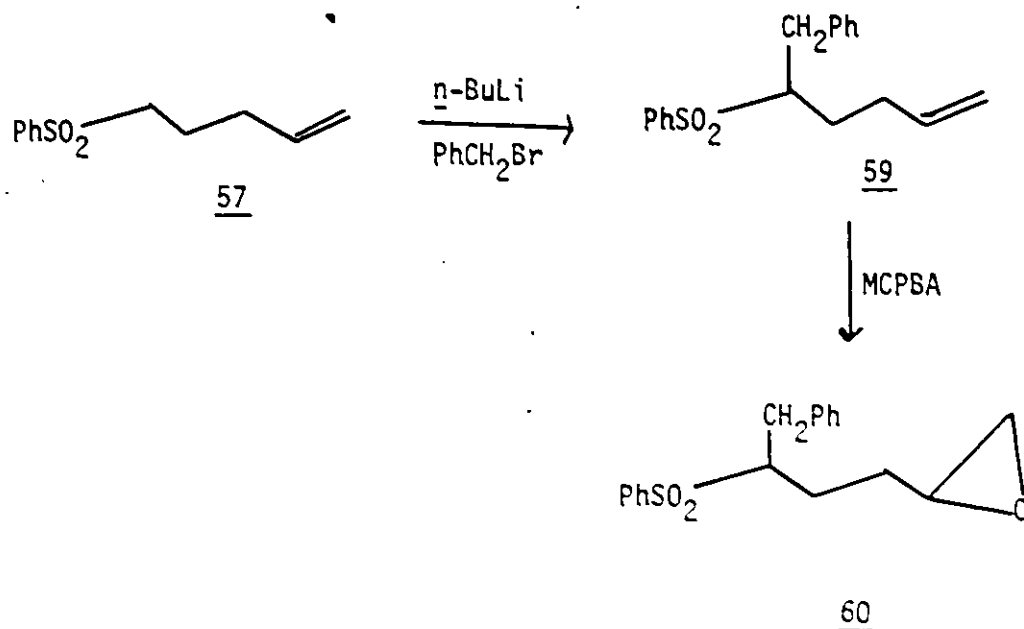

The two disubstituted epoxides 69 and 70 used in this study were prepared starting from tetrahydrofuran according to Schemes 4 and 5.

Treatment of tetrahydrofuran with acetyl chloride under zinc chloride catalysis furnished the chloroester 61 in 86% yield. NMR  $\delta$ : 1.4-2.1 (m, 4H), 2.00 (s, 3H), 3.4-3.7 (m, 2H), 3.9-4.3 (m, 2H). This reaction is very exothermic and external cooling (ice bath) is essential to contain the reaction if carried out in a 0.5 mole scale.

The chloroester 61 was reacted with phenylmercaptide and when the displacement reaction was complete as judged by TLC the ester was saponified by addition of excess potassium hydroxide. The hydroxy sulfide 62, NMR  $\delta$ : 1.5-1.9 (m, 4H), 2.6-3.1 (m, 2H), 3.2-3.7 (m, 3H, 2H after  $\text{D}_2\text{O}$  exchange) and 6.8-7.2 (m, 5H); IR  $3440\text{ cm}^{-1}$  (OH), was subsequently oxidized with two equivalents of MCPBA which provided the hydroxy sulfone 63 in 70% chromatographed yield. NMR  $\delta$ : 1.4-2.0 (m, 3H), 2.6-2.9 (1H, exchanges with  $\text{D}_2\text{O}$ ), 3.16 (t,  $J=7\text{ Hz}$ , 2H), 3.58 (t,  $J=6\text{ Hz}$ , 2H), 7.4-7.9 (m, 5H); IR  $3415\text{ cm}^{-1}$  (OH). The above hydroxy sulfone was also prepared

Scheme 4

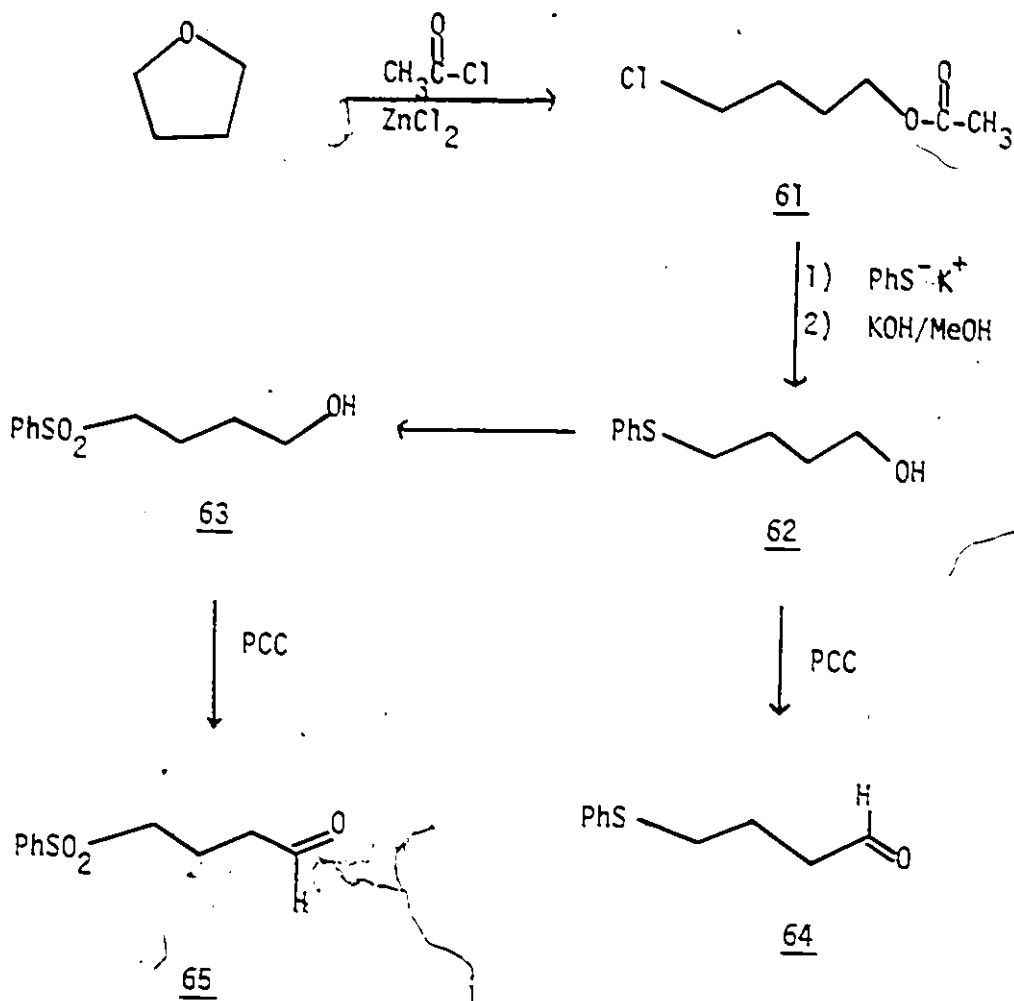

Scheme 5

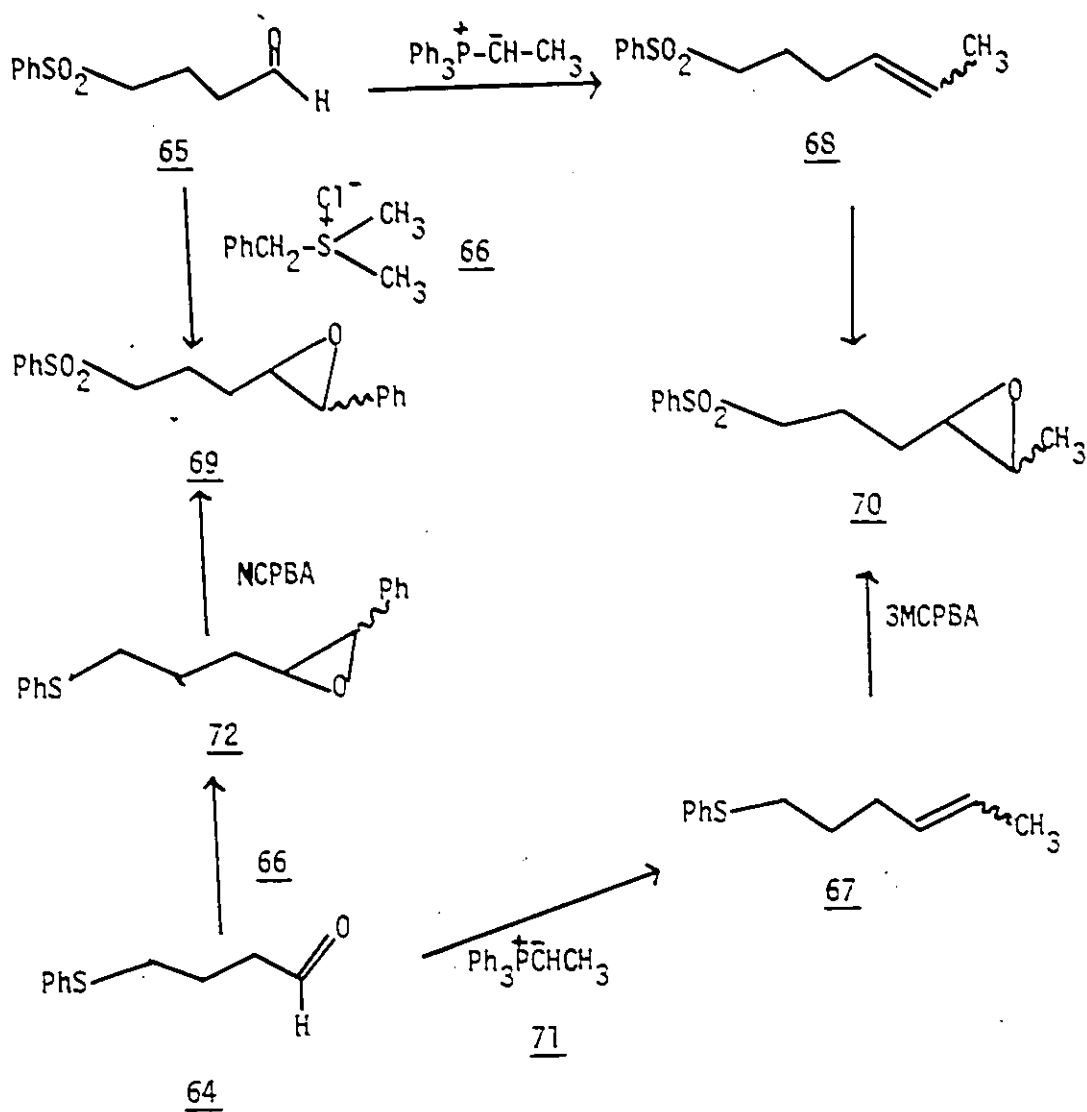

in 70% yield by hydroboration of the olefin 53.

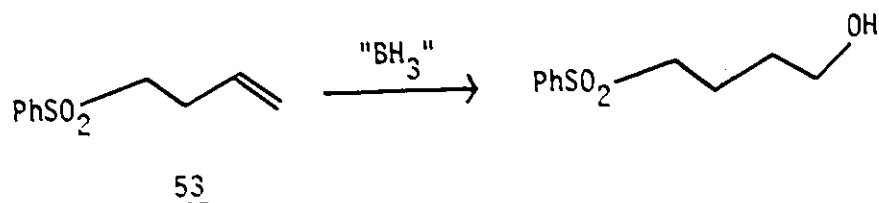

Oxidation of the alcohols 62 and 63 with Corey's (34) procedure (PCC-pyridinium chlorochromate in methylene chloride) provided the corresponding aldehydes in only 20-30% yield. Attempts to improve these yields by varying the rate of addition of the alcohol, volume of solvent, and insuring anhydrous conditions were not successful. However, by addition of four equivalents of sodium carbonate to the suspension of PCC in methylene chloride the yields of aldehydes could be increased to the 70% range.

The structure of the aldehydes was confirmed by the NMR and IR data. Aldehyde 64 showed NMR peaks at  $\delta$ : 1.3-1.9 (m, 2H), 2.1-2.6 (m, 2H), 2.83 (t, J=7Hz, 2H), 6.8-7.2 (m, 5H) and 10.00 (s, 1H). Coupling of the aldehydic hydrogen was not observed at 60 MHz in  $\text{CDCl}_3$  solution. The infrared spectrum showed the carbonyl stretch at  $1710 \text{ cm}^{-1}$ . NMR signals for aldehyde 65 were observed at  $\delta$ : 1.8-2.2 (m, 2H), 2.70 (t, J=6Hz, 2H), 3.20 (t, J=6Hz, 2H), 7.4-7.9 (m, 5H) and 9.74 (s, 1H); IR absorptions were at  $1715 \text{ cm}^{-1}$  (C=O) and 1150, 1310 ( $\text{SO}_2$ ).

Reaction of the sulfone aldehyde 65 with dimethylbenzylsulfonium chloride 66 (prepared by refluxing an aqueous solution of benzyl chloride and dimethyl sulfide (35)) under phase-transfer conditions gave the epoxy sulfone 69 in 50% yield as a clear oil after chromatography. NMR peaks occurred at  $\delta$ : 1.5-2.1 (m, 4H), 2.8-3.4 (m, 3H), 3.56 and 4.40 (two

doublets,  $J=2$  and  $4\text{Hz}$ ,  $1\text{H}$ ) and  $7.1-7.9$  (m,  $10\text{H}$ ). Integration of the two doublets centered at  $3.56$  and  $4.40$  gave an  $85:15$  trans/cis epoxide ratio based on the trans isomer having the smaller coupling constant. The infrared spectrum showed the sulfone stretch at  $1155$  and  $1300$   $\text{cm}^{-1}$ .

The chloride salt of 66 is required in the phase transfer reaction. Attempted reaction of 65 with the bromide salt of 66 was not successful. This may be attributed to deactivation of the phase transfer catalyst whereby bromide ion is transported from the aqueous phase in preference to hydroxide ion.

Reaction of 65 with ethylenetriphenylphosphorane 71 gave the olefin 68 in only 25% yield. NMR  $\delta$ :  $1.1-2.3$  (m,  $7\text{H}$ ),  $2.9-3.3$  (m,  $2\text{H}$ ),  $4.9-5.6$  (m,  $2\text{H}$ ),  $7.3-7.9$  (m,  $5\text{H}$ ); IR  $1600$   $\text{cm}^{-1}$  (C=C). Usual epoxidation of this material with MCPBA afforded the epoxy sulfone 70 in 92% yield as a clear oil which showed NMR peaks at  $\delta$ :  $1.18$  (d,  $J=5\text{Hz}$ ) and  $1.30$  (d,  $J=5\text{Hz}$ )  $3\text{H}$ ,  $1.0-2.2$  (m,  $4\text{H}$ ),  $2.3-3.4$  (m,  $4\text{H}$ ) and  $7.4-7.8$  (m,  $5\text{H}$ ). The relative intensity of the two methyl doublets indicated that the epoxy sulfone 70 thus obtained was a  $50:50$  cis/trans mixture. The infrared spectrum of 70 showed sulfone absorption at  $1150$  and  $1310$   $\text{cm}^{-1}$ .

Epoxidation of the sulfide 64 with the sulfonium salt 66 provided the epoxy sulfide 72 which was oxidized to the sulfone 69 in 60% overall yield.

The sulfide aldehyde 64 was also reacted with the ylide of 71, thus furnishing a 91% yield of the olefin 67. NMR  $\delta$ :  $1.0-1.7$  (m,  $7\text{H}$ ),  $1.7-2.3$  (m,  $2\text{H}$ ),  $2.80$  (t,  $J=6\text{Hz}$ ,  $2\text{H}$ ),  $4.7-5.4$  (m,  $2\text{H}$ ),  $6.7-7.1$  (m,  $2\text{H}$ ); IR  $1600$   $\text{cm}^{-1}$  (C=C). The use of the sulfide in the Wittig reaction was a large improvement compared to the use of the sulfone (90% vs 25%).

The major reason for the vast increase in yield can be ascribed to the greater ease of separating the sulfide olefin 67 from other polar impurities (eg. triphenylphosphine oxide).

Oxidation and epoxidation of 67 with three equivalents of MCPBA provided the epoxy sulfone 70 in 85% yield. Examination of the NMR indicated that this material was also a 50:50 mixture of cis and trans isomers.

### Base Induced Cyclizations

The cyclization reactions were carried out following the procedures developed by Corbel. The reactions employing methylmagnesium iodide as the base were carried out as follows; the appropriate epoxy sulfone was dissolved in freshly distilled THF and then cooled to  $-78^{\circ}$  under nitrogen, this was followed by addition of the required amount of standardized methylmagnesium iodide in ether. The resultant white suspension was allowed to warm to room temperature and then let stir for periods of 12-48 hrs., depending on convenience. After this period, the reaction was quenched with a saturated solution of ammonium chloride and worked up in the usual manner.

Reactions involving LDA or *n*-BuLi as the base were carried out in an analogous manner.

#### $\gamma$ -Epoxy Sulfones

The cyclization of epoxy sulfone 54 had been studied by Corbel. It was repeated in order to acquaint myself with the experimental conditions and to further characterize the product. The reaction was carried out a number of times and yields of 75-90%, comparable to Corbel's 96% reported yield, were generally obtained.

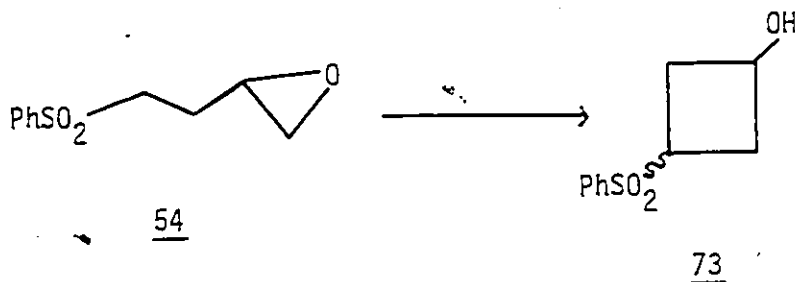

The cyclobutanol structure 73 was supported by the spectral and analytical data. The infrared spectrum of 73 displayed the hydroxyl band at  $3500\text{ cm}^{-1}$  and the sulfone grouping at  $1130$  and  $1300\text{ cm}^{-1}$ . The  $^1\text{H}$  and  $^{13}\text{C}$  NMR data presented below were also consistent with the assigned structure.

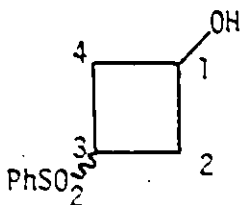

$^1\text{H}$  NMR

$\delta$ : 2.3-2.8 (m, 4H),  $\text{C}_2, \text{C}_4$  - H  
 3.95 (d, 1H, OH)  
 3.1-3.5 (m, 1H),  $\text{C}_3$  - H  
 4.0-4.6 (m, 1H)  $\text{C}_1$  - H  
 7.4-8.0 (m, 5H) aromatics

$^{13}\text{C}$  NMR

$\text{C}_1$	60.9 (d)	$\text{C}_1$	64.0
$\text{C}_2$ and $\text{C}_4$	34.3 (t)	$\text{C}_2$ and $\text{C}_4$	33.6
$\text{C}_3$	48.5 (d)	$\text{C}_3$	52.5

It was observed that if the reaction was carried out for a reasonably short time (8-12 hrs.) using only two equivalents of base essentially one isomer was observed judging from the one proton multiplet for  $\text{CH-OH}$  centered at  $\delta$ :4.2. In contrast, longer reaction times (24 hrs.) or large excesses of  $\text{CH}_3\text{MgI}$  gave an approximate 2:1 isomeric mixture as evidenced by appearance of a second multiplet

centered at  $\delta:4.4$ . The  $^{13}\text{C}$  NMR spectrum also substantiated the existence of two isomers. (ie. doubling up of  $^{13}\text{C}$  signals).

These results indicate that the parent cyclobutanol was probably formed in a highly stereoselective manner (see also section on Stereochemistry) and then underwent isomerization via the intermediacy of the dianion 74 (Scheme 6).

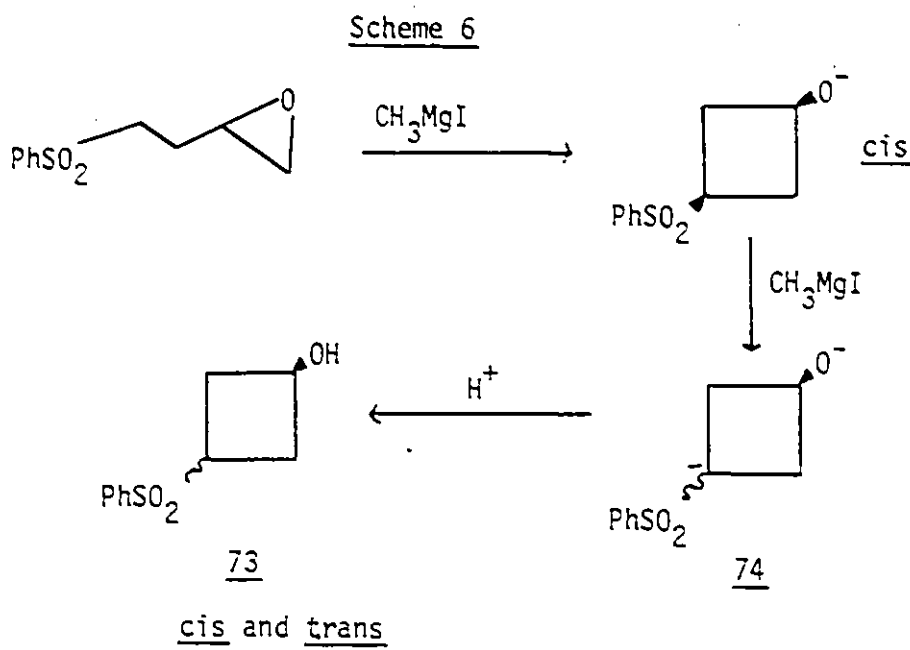

As was described in the introduction to this section Corbel had studied both the LDA-and  $\text{CH}_3\text{MgI}$ -catalyzed cyclization of a variety of substituted  $\gamma$ -epoxy sulfones and shown that with terminal epoxides the  $\text{CH}_3\text{MgI}$  mediated cyclization always afforded 3-phenylsulfonylcyclobutanols. The relative stereochemistry between the hydroxyl and phenylsulfonyl groups in both 3-phenylsulfonylcyclobutanols and-cyclopentanols is depicted as cis throughout the thesis. Evidence for this assignment is presented in the section on stereochemistry.

### $\delta$ -Epoxy Sulfones

Cyclization of the  $\delta$ -epoxy sulfone 58 with methylmagnesium iodide afforded the cyclopentanol 75 in 75% yield after chromatography.

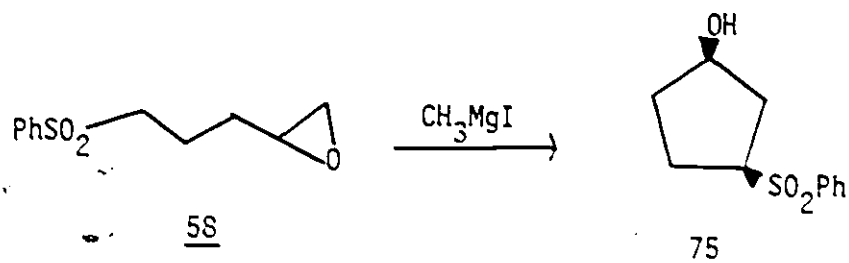

This clear, viscous oil showed  $^1\text{H}$  NMR peaks at  $\delta$ :3.5-3.9 (m,1H) and 4.2-4.6 (m,1H) assignable to the hydrogens on the carbons bearing the  $\text{SO}_2\text{Ph}$  and  $\text{OH}$  groups respectively. In addition, peaks due to three methylene units (1.7-2.4,m), the  $\text{OH}$  (2.9-3.1) and the aryl group (7.4-7.9) were observed.

In contrast, treatment of the above epoxy sulfone 58 with LDA gave only starting material and intractable products which were not identified. A similar result had been observed by Lallemand and Onanga (10) who reported that treatment of the epoxy nitrile 76 with sodamide in dry THF gave, in contrast to epoxy nitriles which with terminal substituents gave cyclic products, "no reaction" presumably meaning that no cyclization products were obtained.

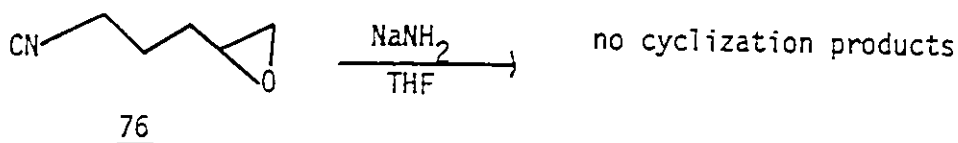

The reason for the behaviour of 58 and 76 with LDA is not clear. Three competing reactions are possible for the intermediate  $\alpha$ -cyano or  $\alpha$ -sulfonyl carbanions.

- (i) exo-cyclization to give a cyclobutyl methanol
- (ii) endo-cyclization affording cyclopentanol derivatives, and
- (iii) intermolecular epoxide opening probably at the terminal position to give dimeric and polymeric species.

Presumably pathway (iii) becomes the most favoured process because it is sterically unhindered and suffers neither from the colinearity problem associated with the 5-endo process or the enthalpy problem generally associated with the formation of four-membered rings.

The reaction of 58 with LDA, as was the case with most other epoxy sulfone cyclizations, was carried out at a concentration of approximately 0.02 M. No further dilution studies were carried out in this particular case.

#### "One-Pot" Preparation of Cyclobutanols and Cyclopentanols

The preparation of some 3-phenylsulfonyl cyclobutanols and cyclopentanols was achieved under "one-pot" conditions according to Scheme 7.

Thus, reaction of phenyl methyl sulfone 77 with one equivalent of  $\text{CH}_3\text{Li}$  in THF containing 5% hexamethylphosphoramide (HMPTA) at  $-70^\circ$  followed by sequential addition of epibromohydrin ( $n=1$ ) and  $\text{CH}_3\text{MgI}$  and warming to room temperature overnight gave the parent

cyclobutanol (n=1) 73 in 46% yield.

Scheme 7

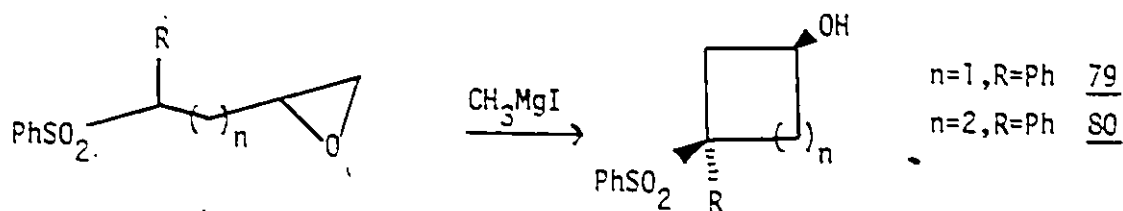
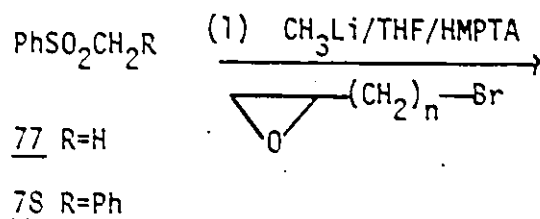

Replacement of phenyl methyl sulfone in the above sequence with benzyl phenyl sulfone (R=Ph) 78 provided the 3-phenyl cyclobutanol derivative 79 in 60% yield. This white solid (mp 132° from  $\text{CH}_2\text{Cl}_2/\text{CCl}_4$ ) showed NMR signals at  $\delta$ : 2.9-3.3 (m, 5H, 4H after  $\text{D}_2\text{O}$  exchange), 4.18 (quintet, J=6, 5Hz, 1H), and 6.8-7.7 (m, 10H). An X-ray of this material is reported in the section on Stereochemistry.

The parent cyclopentanol 75 was obtained in 35% yield via the above sequence using phenyl methyl sulfone 77 and 4-bromo-1,2-epoxybutane (n=2) as the two starting components.

Also prepared by this route, beginning with benzyl phenyl sulfone 78 and 4-bromo-1,2-epoxybutane was 3-phenylsulfonylcyclopentanol

derivative 80. This viscous oil, obtained in 75% yield, displayed NMR peaks at  $\delta$ :2.0-3.4 (m,6H), 3.4-3.8 (1H,OH), 4.2-4.6 (m,1H), and 7.0-7.6 (m,10H). The infrared spectrum of 80 showed the OH stretch at  $3500\text{ cm}^{-1}$  and the  $\text{SO}_2$  group at  $1130$  and  $1300\text{ cm}^{-1}$ .

The use of HMPTA as a cosolvent (36) in the above "one-pot" reactions was absolutely necessary since reactions attempted without it did not yield any appreciable amounts of cyclization products.

Surprisingly, the attempted "one-pot" reaction employing butyl phenyl sulfone and 4-bromo-1,2-epoxybutane gave the cyclization product in less than 5% yield. Examination of the crude NMR indicated that the starting material constituted the vast majority (95%) of the crude reaction mixture. This lack of success may be due to inefficient alkylation of the  $\alpha$ -sulfonyl carbanion possibly due to increased steric effects in the anion.

#### Mechanism of the "One-Pot" Reactions

Two modes of attack by the  $\alpha$ -sulfonyl carbanion on the bromo epoxides ( $n=1,2$ ) may be envisaged; these are shown in Scheme 8 and discussed below.

Attack of the carbanion via path A results in formation of the  $\gamma$ -epoxy sulfone which subsequently cyclizes via the usual alkoxide intermediate to the 3-phenylsulfonylcyclobutanol.

Attack of the anion at the primary site of the epoxide (path B) initially yields the same bromo alkoxide intermediate and thus the same cyclobutanol product. Therefore, product analysis does not allow differentiation of the two processes.

Scheme 8

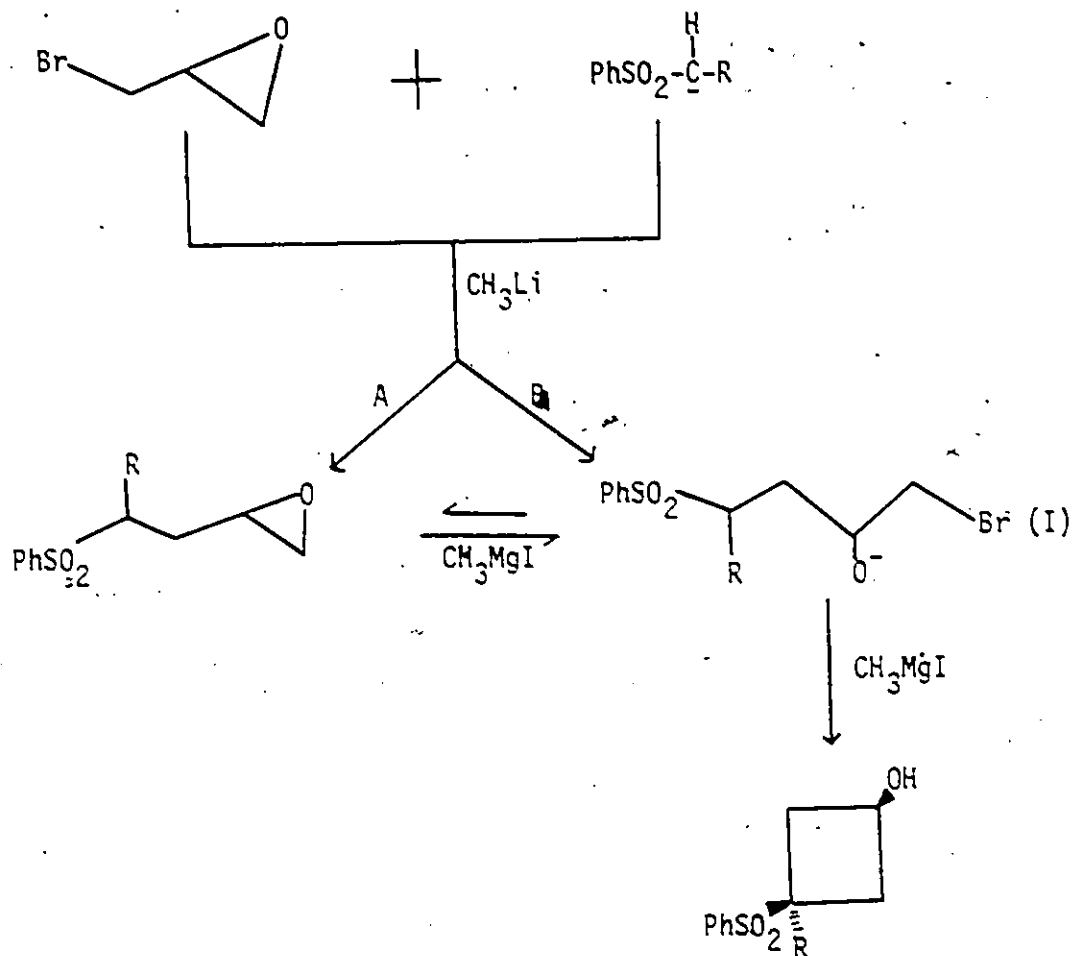

A similar situation exists in the reaction of the  $\alpha$ -sulfonyl carbanions and 4-bromo-1,2-epoxybutane. (Scheme 9)

In path A, displacement of bromide ion from 4-bromo-1,2-epoxybutane by the  $\alpha$ -sulfonyl carbanion results in formation of a  $\delta$ -epoxy sulfone which subsequently can undergo cyclization via the usual halohydrin intermediate.

Opening of the epoxide (path B) furnishes the  $\gamma$ -halohydrin intermediate which upon cyclization affords the identical cyclopentanol derivatives as in path A.

Scheme 9

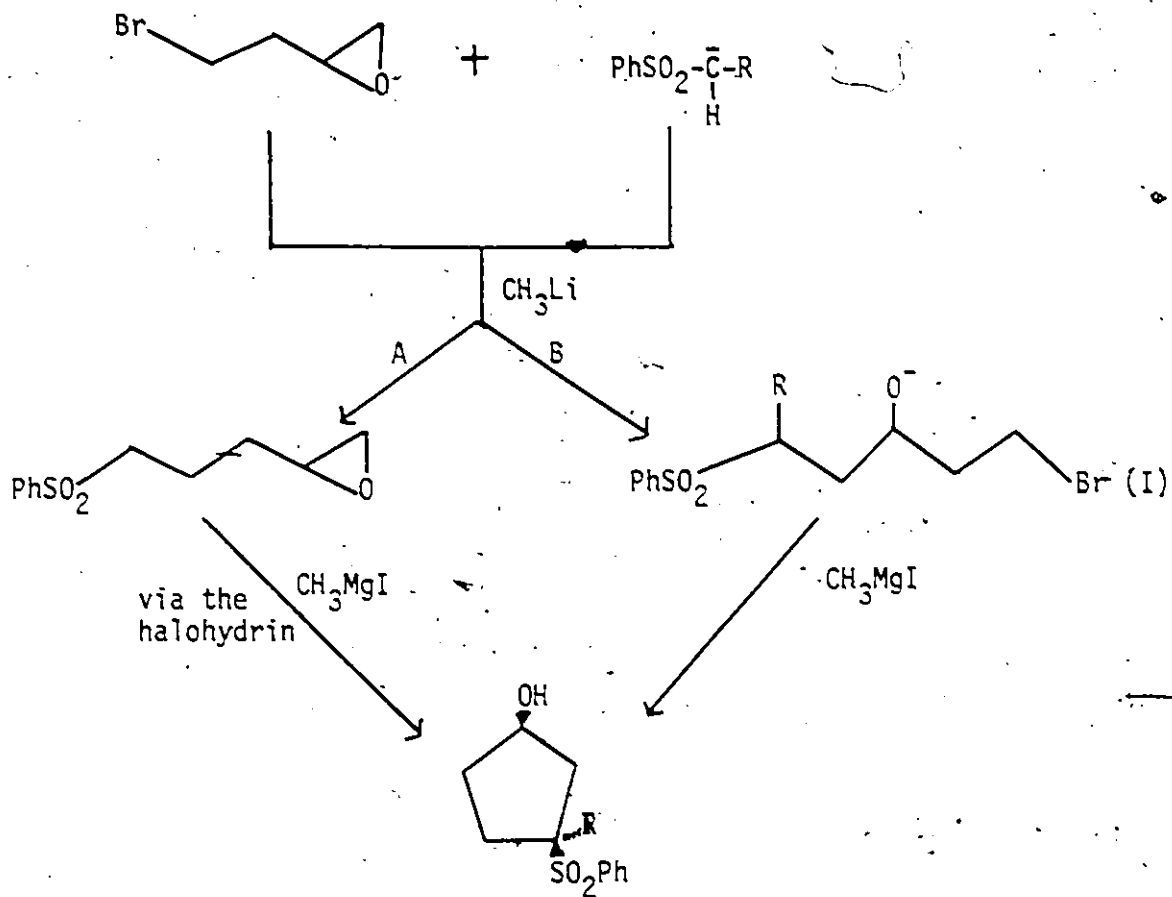

The work of Cruickshank and Fishman (18) suggests that path A is more feasible under our reaction conditions. These authors found that reaction of bromo epoxides with nucleophiles in aprotic solvents proceeded via displacement of bromide ion. The greater susceptibility of the carbon-bromine bond to nucleophilic attack in aprotic solvents was considered to account for the formation of epoxyalkyl products.

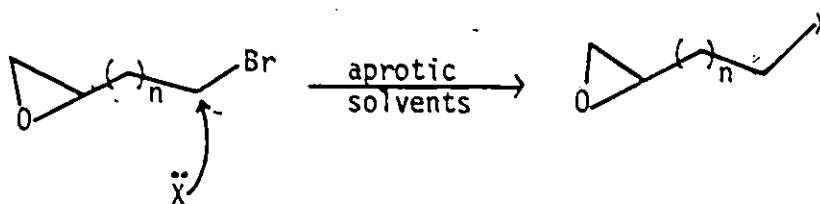

The use of protic solvents (alcohols) resulted in attack by the nucleophile at the primary oxirane carbon. This behaviour was accounted for in terms of the weakening of the carbon-oxygen bond in alcoholic solvents, due to hydrogen bonding, such that nucleophilic attack at the primary oxirane position becomes favoured.

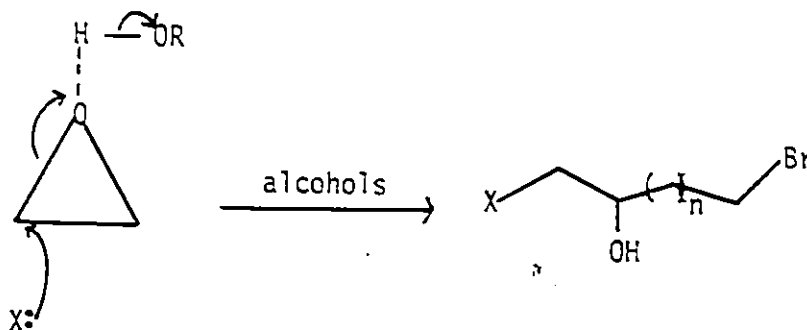

The above work, coupled with our own observation that the product obtained in the initial step (epoxide and  $\alpha$ -sulfonyl carbanion) has an  $R_f$  comparable to an authentic sample of the corresponding epoxy sulfone suggests that the initial alkylation product is formed via path A.

#### Internally Substituted Epoxy Sulfones

The  $\gamma$ -epoxy sulfone 69, when treated with two equivalents of  $CH_3MgI$  furnished the cyclopentanol 81 in 67% yield.

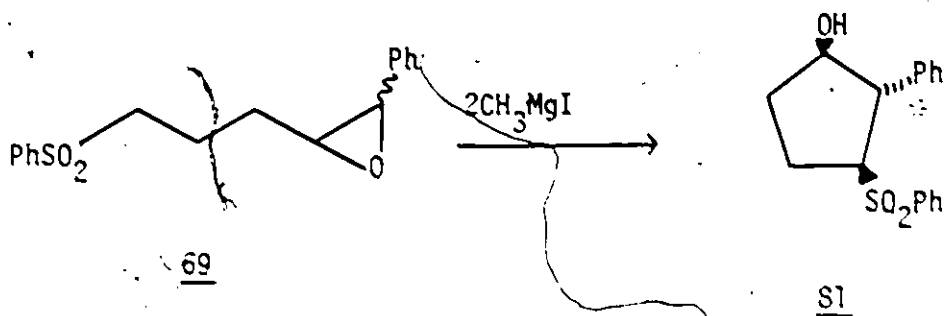

Compound S1 (m.p. 105-106 from  $\text{CH}_2\text{Cl}_2/\text{hexane}$ ) exhibited NMR peaks at  $\delta$ : 1.7-2.6 (m, 5H, 4H after  $\text{D}_2\text{O}$  exchange), 3.2-3.4 (m, 1H), 3.5-3.8 (m, 1H), 3.9-4.2 (m, 1H) and 6.8-7.8 (m, 10H). The infrared spectrum showed the OH bond at  $3500\text{ cm}^{-1}$  and the  $\text{SO}_2$  band at 1145 and  $1310\text{ cm}^{-1}$ . The assigned structure was also consistent with the  $^{13}\text{C}$  NMR data which is presented below.

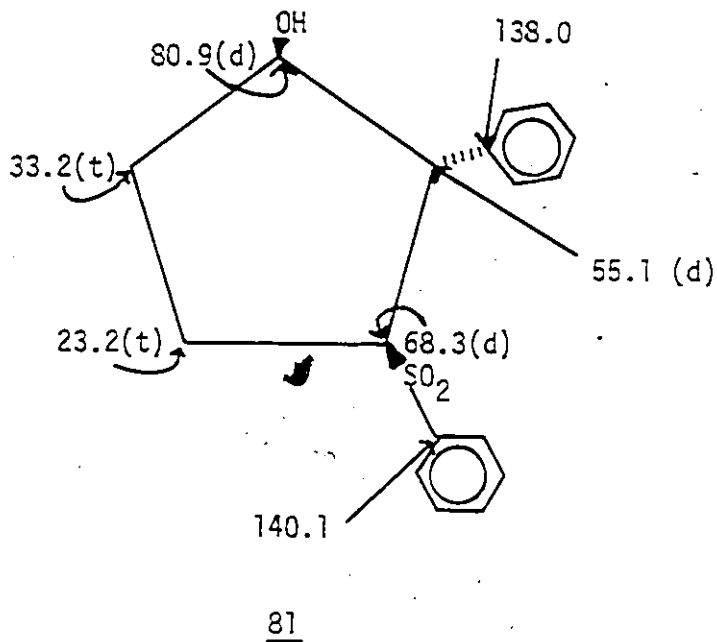

Treatment of the epoxy sulfone 69 with LDA furnished a product (75%) which was identical in all respects to the product described below. The 2- phenylcyclopentanol S1 obtained from both the LDA and  $\text{CH}_3\text{MgI}$  reaction is believed to be a single isomer based on its sharp melting point and the  $^{13}\text{C}$  data which showed no evidence of line doubling. Some doubling of lines would have been expected if two diastereoisomers had been present.

The above stereochemical assignment is made on the basis of a detailed consideration of both the LDA and Grignard reaction pathways.

Based on an  $\text{S}_{\text{N}}2$  opening of the trans epoxide (present to the extent of 55% in the starting material) with inversion of configuration at the oxirane carbon the hydroxyl and phenyl groups must occupy a trans orientation to each other in the product.

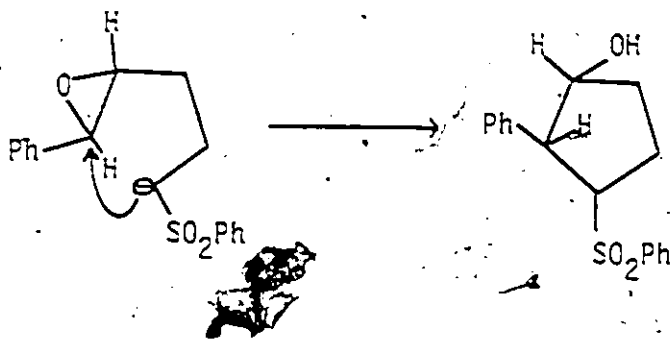

The cis orientation of the phenylsulfonyl and hydroxyl groups is assigned on the basis of evidence presented later (Stereochemistry section) regarding the relative stereochemistry of these groups in the  $\text{CH}_3\text{MgI}$ -mediated reaction. In addition this isomer, which is probably thermodynamically more stable, may arise via base-catalyzed epimerization of the C-3 carbon.

It was initially considered quite surprising that the same product was obtained from the LDA and Grignard reactions respectively. An examination of the mechanism for the formation of the cyclopentanol (Scheme 10) from the  $\text{CH}_3\text{MgI}$  reaction allows one to suggest an explanation.

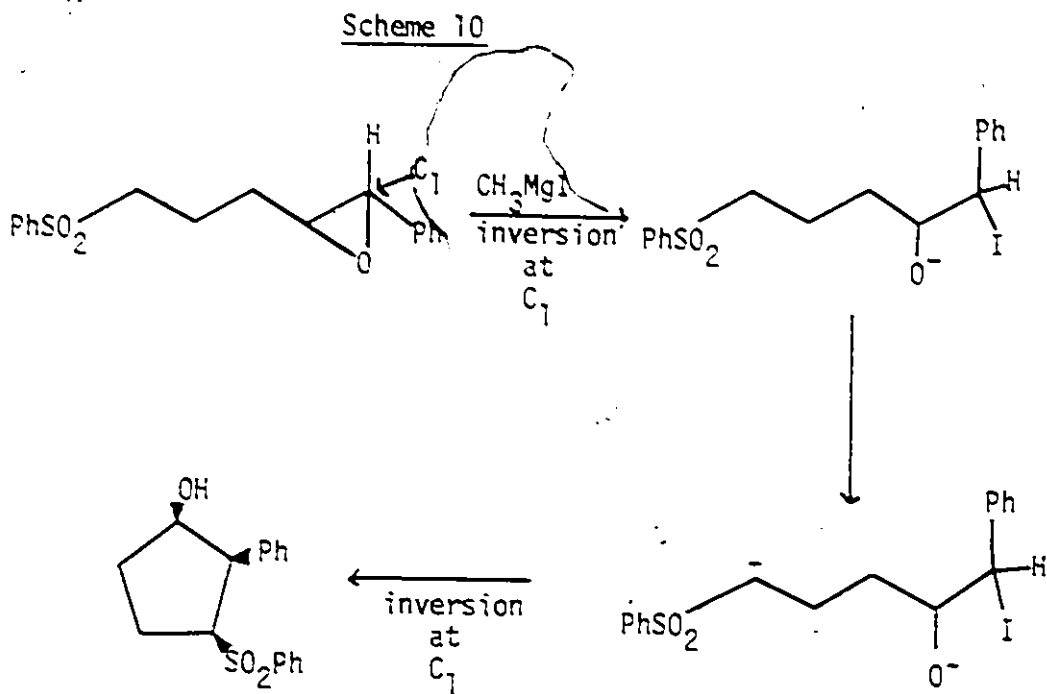

Initial opening of the epoxide to the iodo alkoxide proceeds with inversion of configuration at C-1. Subsequent  $\alpha$ -sulfonyl anion formation followed by intramolecular  $\text{S}_\text{N}2$  displacement of the iodide (another inversion at C-1) would involve overall net retention of configuration at C-1, thus leading to a cis disposition of the hydroxyl and phenyl groups in the cyclopentanol product. As has been indicated in the discussion of the LDA reaction such a cis arrangement is not possible in the LDA reaction. Since the same product is obtained in

both reactions racemization at C-1 in the iodo alkoxide is required prior to cyclization. The mechanism of such an exchange may involve iodide catalyzed epimerization at C-1.

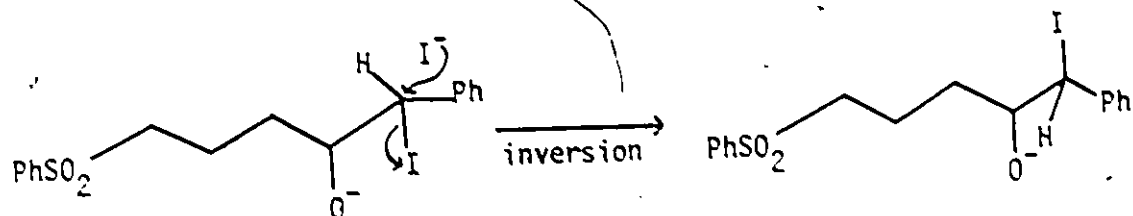

Cyclization of the diastereomer leading to trans hydroxyl and phenylsulfonyl groups is expected to be considerably faster than that leading to a product in which all three adjacent substituents are in a cis arrangement. That such a cyclization is unfavourable is also indicated by the fact that no cis product was observed in the LDA reaction of the epoxy sulfone 69 which was 15% cis as determined by NMR. Presumably the cis epoxy sulfone remains unreacted under LDA conditions.

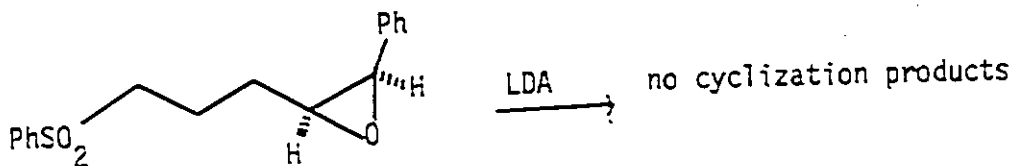

Grignard induced cyclization of the methyl epoxy sulfone 70 afforded the 2-methylcyclopentanol derivative 82 as a clear oil in 50% yield.

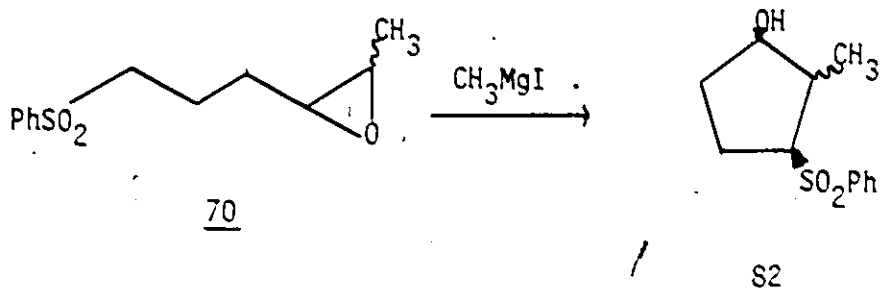

The  $^1\text{H}$  NMR of 82 showed signals at  $\delta$ : 1.02 (d,  $J=6\text{Hz}$ , 3H), 1.6-2.5 (m, 5H), 2.5-2.9 (1H, OH), 3.0-3.3 (m, 1H), 3.6-3.9 (m, 1H), and 7.4-7.9 (m, 5H); IR 3450 (OH) and 1150, 1300  $\text{cm}^{-1}$  ( $\text{SO}_2$ ).

The  $^{13}\text{C}$  NMR data, shown below also supported the assigned structure.

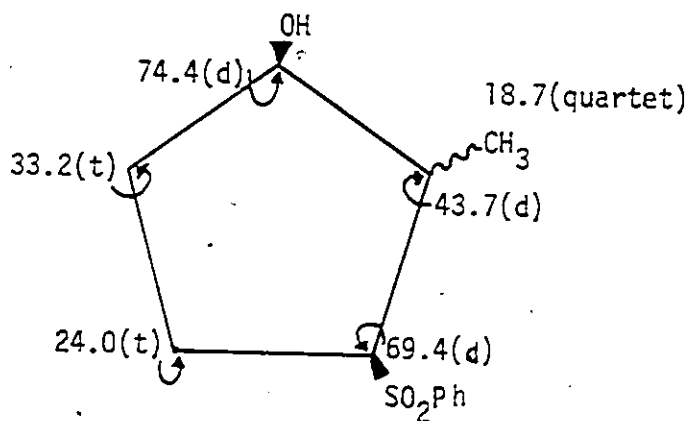

The structure of 82 was further verified by careful Jones oxidation to the keto sulfone 83 which showed the carbonyl stretch at  $1750\text{ cm}^{-1}$  in its infrared spectrum and NMR peaks at  $\delta$  1.13 (d, J=6Hz, 3H), 2.0-2.8 (m, 5H), 3.3-3.5 (m, 1H) and 7.5-8.0 (m, 5H).

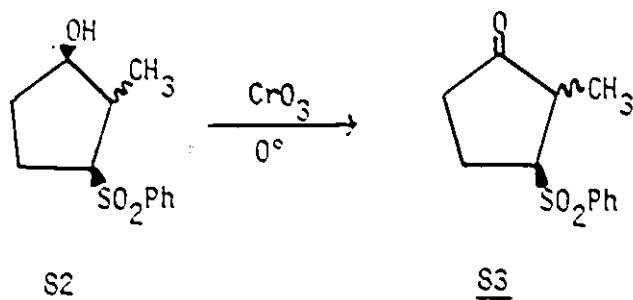

The epoxy sulfone 70, when reacted with LDA provided a product whose structure was not established.

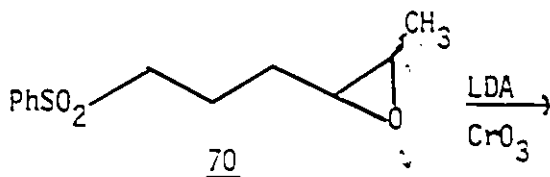

The  $^{13}\text{C}$  NMR spectrum of the product (s) indicated twelve non-aromatic carbons suggesting a dimeric structure. Assignments from the off-resonance partially coupled spectrum were not possible due to extensive overlap. The infrared spectrum showed that OH ( $3400\text{ cm}^{-1}$ ) and sulfone ( $1155, 1318\text{ cm}^{-1}$ ) units were present. Treatment of the above compound(s) with  $\text{CrO}_3$  followed by  $\text{NEt}_3$  yielded a product which

by NMR had retained the PhSO<sub>2</sub> grouping; no olefinic hydrogens were present. The infrared spectrum of this product indicated that oxidation had occurred as evidenced by disappearance of the hydroxyl band and appearance of carbonyl stretching frequencies at 1715 and 1745 cm<sup>-1</sup>. The above data suggests that a  $\beta$ -hydroxy sulfone unit is not present since the base treatment should have resulted in the elimination of PhSO<sub>2</sub>H and formation of an enone. The available data are somewhat conflicting and it is not possible to suggest a structure for this reaction product(s).

### Conclusions

Some mechanistic aspects of the Grignard reaction have already been described. A further and more complete discussion is presented in the section on Mechanism.

The results obtained with the LDA reactions of internally substituted epoxy sulfones 69 and 70 are contrary to expectations based on literature precedence. Formation of the cyclopentanol derivative 81 from the phenyl epoxy sulfone 69 is contrary to Stork's (7,8) prediction of preferential cyclobutane formation with equal substitution on the epoxide. Cyclopentanol formation is not unexpected considering the work reported by Lallemant and Onanga (10) who reported that reaction of trans  $\delta$ -epoxy nitriles with sodamide in dry THF afforded a mixture of cyclobutyl and cyclopentyl derivatives in a 2/1 ratio with the cyclopentane derivatives predominating whereas reaction of the cis epoxides gave exclusively cyclobutyl derivatives.

In our cyclization of 69 no cyclobutyl derivatives were

observed. Possibly the presence of the phenyl group which is known to accelerate  $S_N2$  reactions at the benzylic position accounts for this result.

Failure of the methyl epoxy sulfone 70 to give monomeric cyclic products was completely contrary to all expectations. Since the starting epoxy sulfone 70 was a 50:50 cis/trans mixture both four- and five-membered ring products were expected; but unfortunately none were obtained.

Synthesis of Non-Sulfur Containing Derivatives

From the 3-Phenylsulfonyl Cycloalkanols

- A) Synthesis of Cyclobutenones and Cyclopentenones
- B) Synthesis of Cyclobutanols

Introduction

One of the general goals of our research is to utilize sulfur-stabilized carbanions to direct formation of C-C bonds and then remove the sulfur function thereby generating sulfur free compounds. It was therefore decided to apply the known methods for removal of  $\text{PhSO}_2$  from the 3-phenylsulfonylcycloalkanols.

(i) Reductive elimination

The work of the two groups, Kondo (37) in Japan and Julia (38) in France, have shown that  $\beta$ -keto sulfones are excellent precursors to  $\alpha, \beta$ -unsaturated ketones. An application of this elimination to the synthesis of more complex enones starting from simple vinyl ketones is summarized in Scheme 11. Typically an aryl- or alkylsulfonyl group  $\beta$  to a ketone can be simply removed by treatment with mild bases such as triethylamine or DBU in methylene chloride.

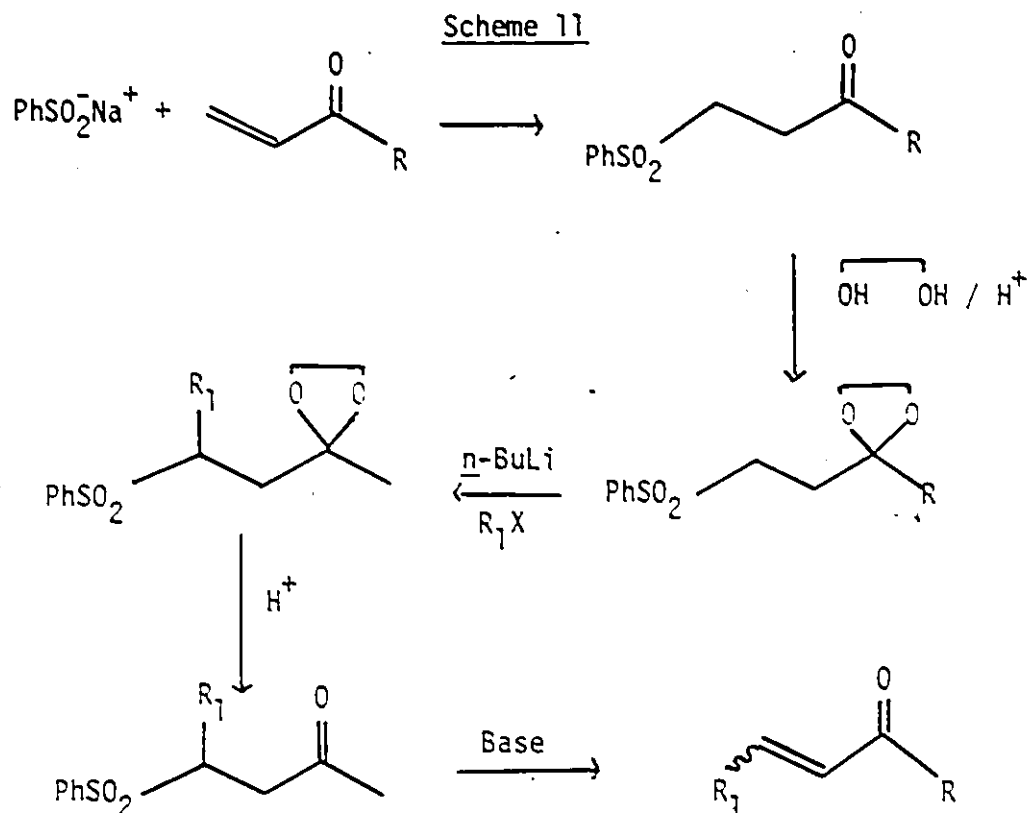

(ii) Hydrogenolysis

Many methods for replacement of a phenylsulfonyl group with hydrogen have been worked out.

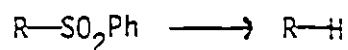

The most important of the methods available for the transformation of a C-S bond into a C-H bond have been Raney nickel (39), lithium in alkylamines (40) and sodium amalgam (41). Reduction of aryl alkyl sulfones can sometimes be complicated by reduction of the aromatic ring without cleavage of the alkyl sulfur bond. The most effective method of removing the phenylsulfonyl group is that of Posner and Brunelle (41). Treatment of sulfones 84 with 6% Na amalgam in

refluxing absolute ethanol provides excellent yields of the desulfonylated materials S5.

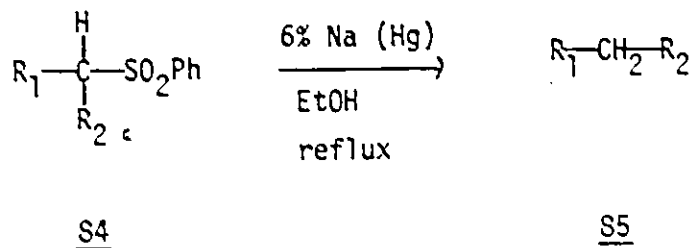

A milder procedure for the effective removal of the phenylsulfonyl group from  $\alpha$ -phenylsulfonyl esters has been developed by Trost et al (42). Treatment of the sulfones S6 with excess 6% Na (Hg) in methanol containing four equivalents of disodium hydrogen phosphate at room temperature led to excellent yields of desulfonylation products S7.

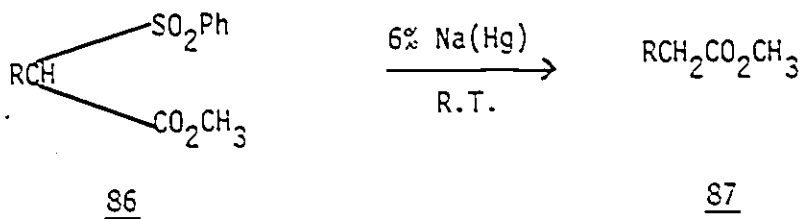

(iii) Oxidative Elimination

The possibility of oxidative removal of the phenylsulfonyl group to give a ketone has not been described in the literature. It was briefly investigated during this work and will be described in Part II of the thesis.

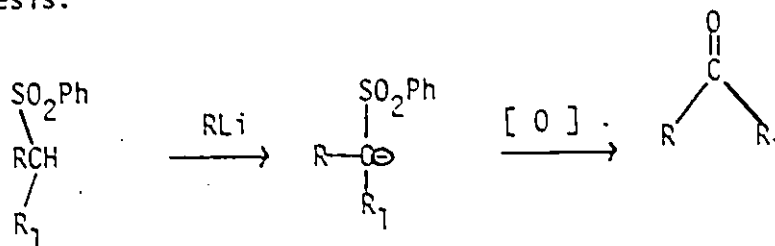

A) Synthesis of Cyclobutenones and Cyclopentenones

Since the epoxy sulfone cyclization led to 3-phenylsulfonyl cyclobutanols and cyclopentanols it was recognized that simple oxidation to the corresponding cycloalkanones followed by mild base treatment would result in the formation of cyclobutenones and cyclopentenones.

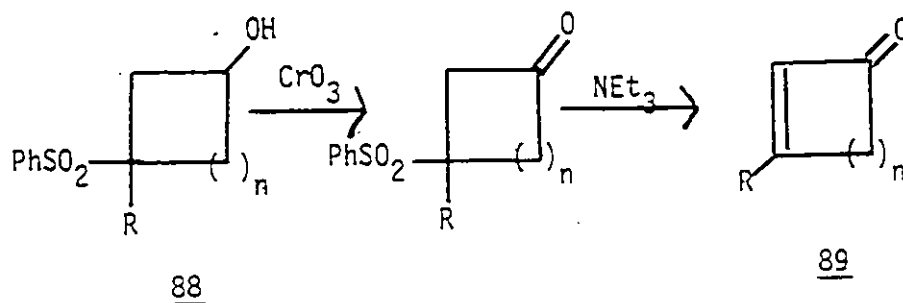

The scope of this route, especially to a variety of 3-substituted derivatives 89 is relatively wide since a variety of 3-substituted derivatives of 88 can be prepared by two possible routes.

The first consists of starting with an appropriately substituted epoxy sulfone. This route has been applied to  $\gamma$  and  $\delta$ -epoxy sulfones.

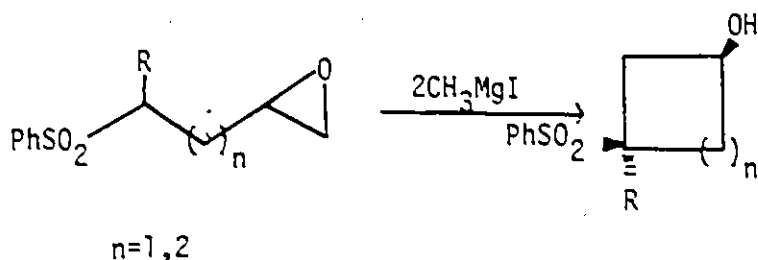

A more versatile route involves the use of the readily available parent compounds 73 and 75. (Scheme 12)

Scheme 12

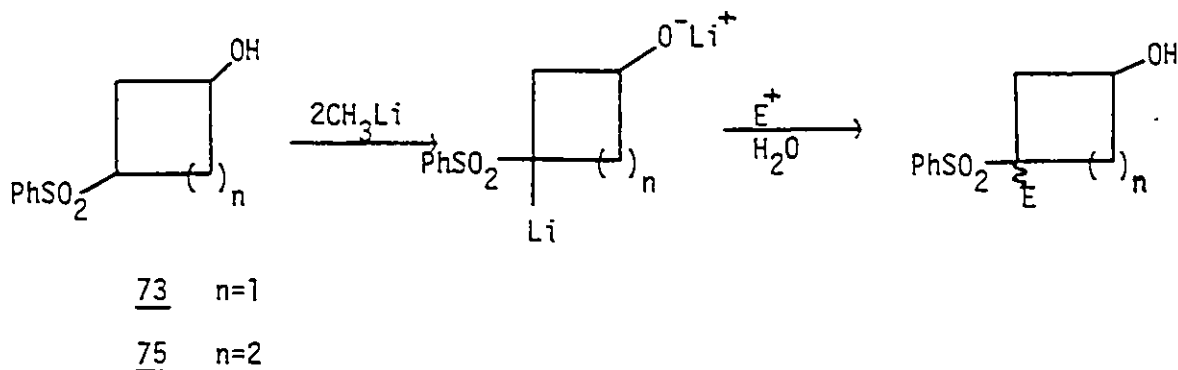

The alkylation reactions were carried out by treatment of the parent cycloalkanol with two equivalents of methyllithium at  $-70^\circ$  in THF, followed by trapping of the  $\alpha$ -sulfonyl carbanion with various electrophiles (Table III). No O-alkylation products were

observed under these conditions.

The reported yields in Table III are for chromatographically pure compounds. The structures of these compounds were established on the basis of their spectral and analytical data (see Experimental Section). The yields of products derived from the alkylation reaction are remarkably high considering that a quaternary center is being generated. For example, the bulky  $\alpha$ -sulfonyl carbanion (which can be considered equivalent to a neopentyl situation) is readily trapped (71%) by the secondary halide, isopropyl bromide.

The formation of diastereomeric mixtures was observed via the alkylation route. This was not important since oxidation converted both diastereomers into the same product.

Table III

Alkylation of 3-Phenylsulfonyl Cycloalkanols

<u>R-X</u>		<u>Product</u>	<u>Yield (%)</u>
	<u>n</u>		
$C_4H_9Br$	1		68
		<u>90</u>	
$C_4H_9Br$	2		80
		<u>91</u>	

Table III (cont'd)



92

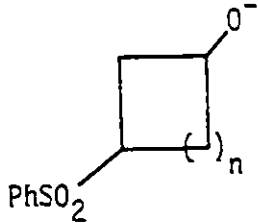
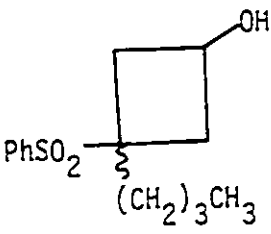
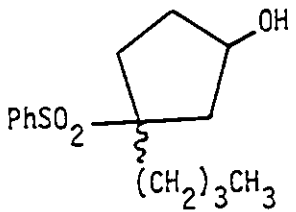
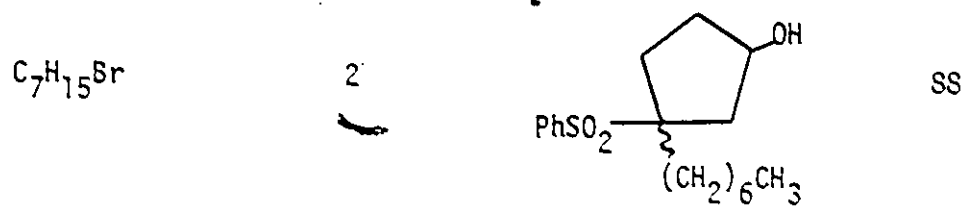
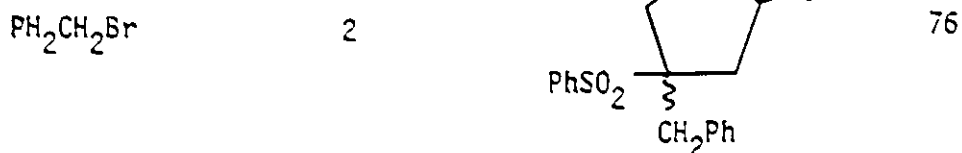

93

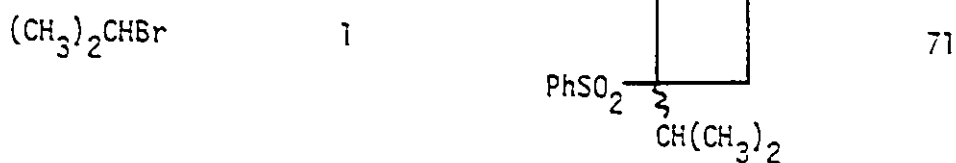

94

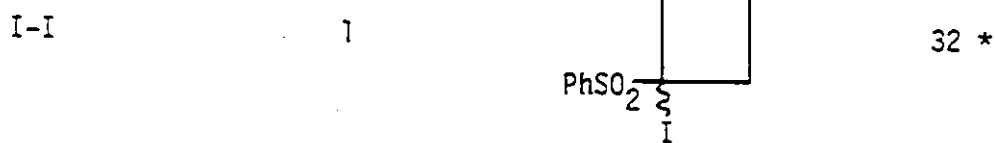

95

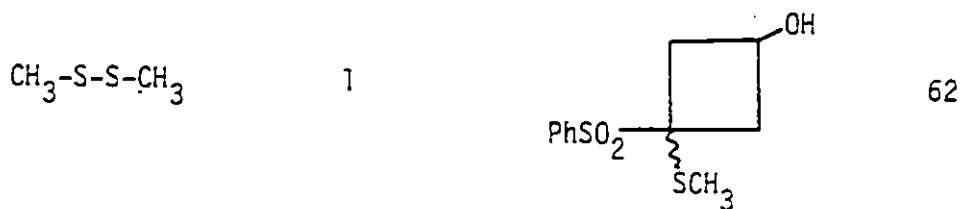

96

\* 64% based on  $I_2$

Oxidation and Elimination Reactions of  
the 3-Phenylsulfonyl Cycloalkanols

The cyclobutenones and cyclopentenones obtained via the oxidation/elimination route are presented in Table IV. Oxidation of the cyclobutanols and cyclopentanols with Jones reagent (43) led in excellent yields (generally 90%) to the corresponding ketones. The  $\beta$ -sulfonylcyclobutenones could be isolated and purified readily. Subsequent treatment with triethylamine in methylene chloride at room temperature furnished the cyclobutenones. Due to the ease of elimination of the phenylsulfonyl group from the 3-phenylsulfonyl cyclopentanones, these intermediate compounds were usually not purified but converted directly to the cyclopentenones. When the crude oxidation product was examined by TLC the presence of cyclopentenones was observed.

The cyclobutenones showed the carbonyl frequency at about  $1760\text{ cm}^{-1}$  and the olefinic stretch at  $1580\text{-}1600\text{ cm}^{-1}$  in the infrared spectra. The NMR of these substances each had two slightly broadened singlets at about  $\delta$  3.2 (2H) and 5.8-6.0 (1H) assignable to the remaining methylene and olefinic hydrogens in the ring.

The various 3-alkylcyclopentenones each showed a one proton multiplet in the  $\delta$ 5.9-6.0 region assignable to the olefinic hydrogen in the ring. The carbonyl and olefinic frequencies in the infrared were observed at  $1700\text{-}1720\text{ cm}^{-1}$  and at  $1620\text{-}1630\text{ cm}^{-1}$  respectively.

Also accessible by the oxidation/elimination route is 2-phenylcyclopentenone<sup>102</sup> which was obtained in 75% yield by treatment of

Table IV

Conversion of 3-Phenylsulfonyl Cycloalkanols into  
3-Substituted Cyclobutenones and Cyclopentenones

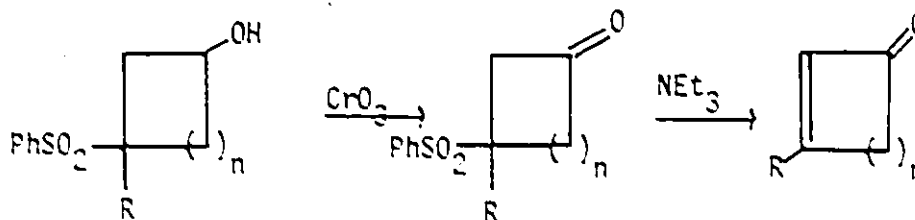

<u>n</u>	<u>R</u>	<u>% Yield</u>
1	Ph*	80
1	n-C <sub>7</sub> H <sub>15</sub> *	83
1	C <sub>4</sub> H <sub>9</sub> *	80
1	iso-C <sub>3</sub> H <sub>7</sub>	82
	<u>97</u>	
2	Ph	75
	<u>98</u>	
2	CH <sub>2</sub> Ph	87
	<u>99</u>	
2	n-C <sub>7</sub> H <sub>15</sub>	75
	<u>100</u>	
2	C <sub>4</sub> H <sub>9</sub>	85
	<u>101</u>	

\* Prepared by B. Corbel

81 under the usual conditions. The structure of 102 was established on the basis of its m.p. 67-68° (Lit. 71°)(44) and its spectral data. In particular, the carbonyl stretch at 1725  $\text{cm}^{-1}$  (Lit. 1726)(44) and the deshielding of  $\text{H}_A$  ( $\delta$ 7.34-7.45) by the proximate  $\beta$ -phenyl and  $\beta$ -carbonyl groups.

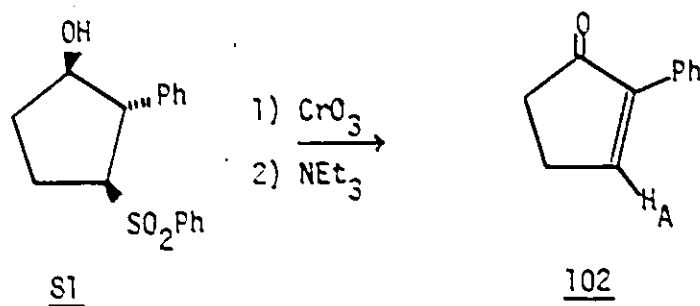

In principle this route may also be applied to the synthesis of 2,3-disubstituted cyclopentenones starting from 2-substituted-3-phenylsulfonyl cyclopentanol as is illustrated in Scheme 13. Such intermediates 103 have been used as prostaglandin precursors (45).

Scheme 13

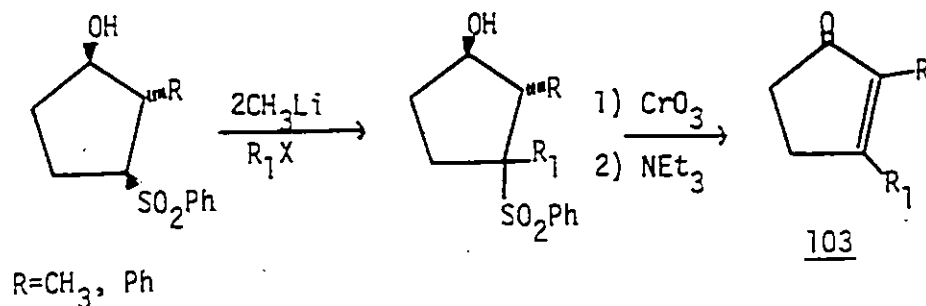

The synthetic scope of the epoxy sulfone cyclization reaction as applied to enone synthesis is summarized in Table V.

Table V  
Synthetic Scope of Epoxy Sulfone Cyclization

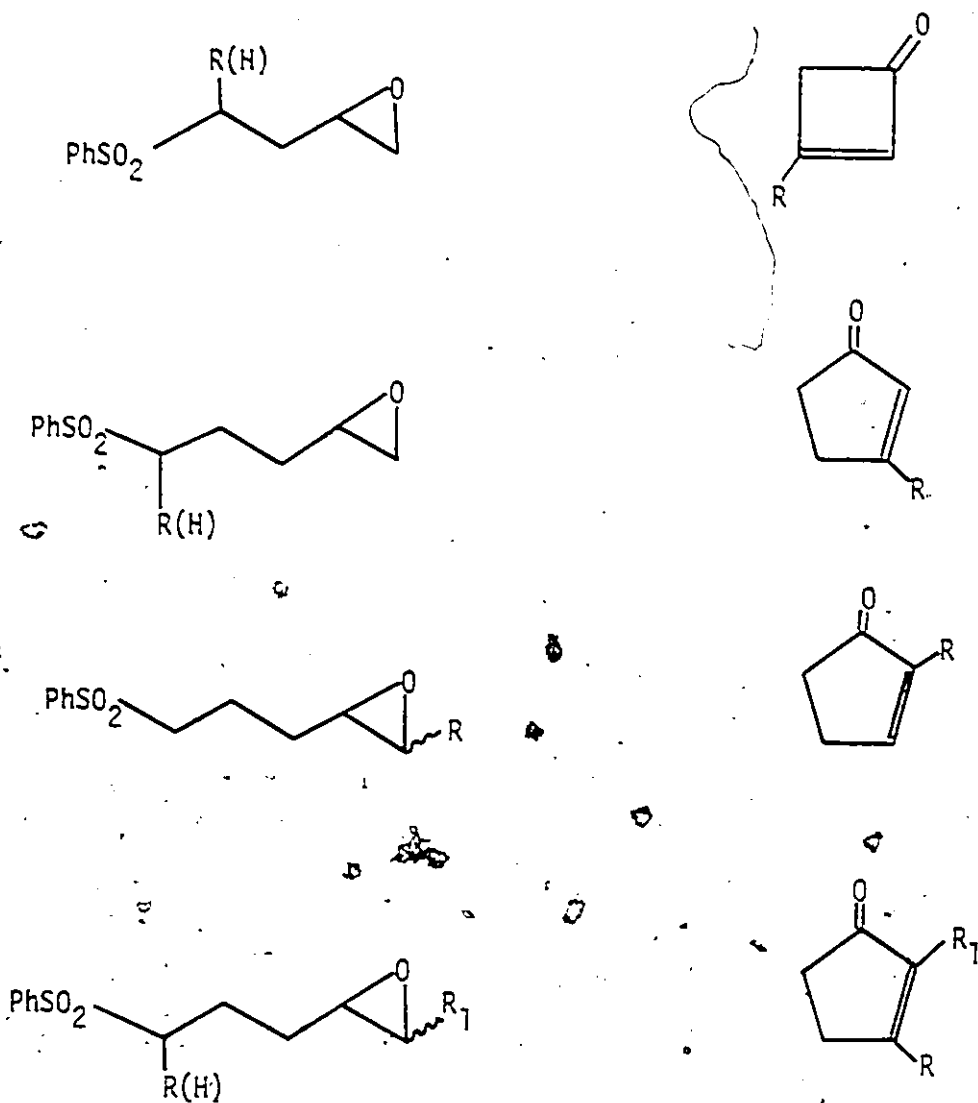

## Other Routes to Cyclobutenones and Cyclopentenones

### Cyclobutenones

The synthesis of cyclobutenones has most often involved cycloaddition of ketenes or allenes to unsaturated systems.

Thus, the first reported (46) isolation of cyclobutenone 104 involved cycloaddition of allene to acrylonitrile as the initial step. (Scheme 14)

Scheme 14

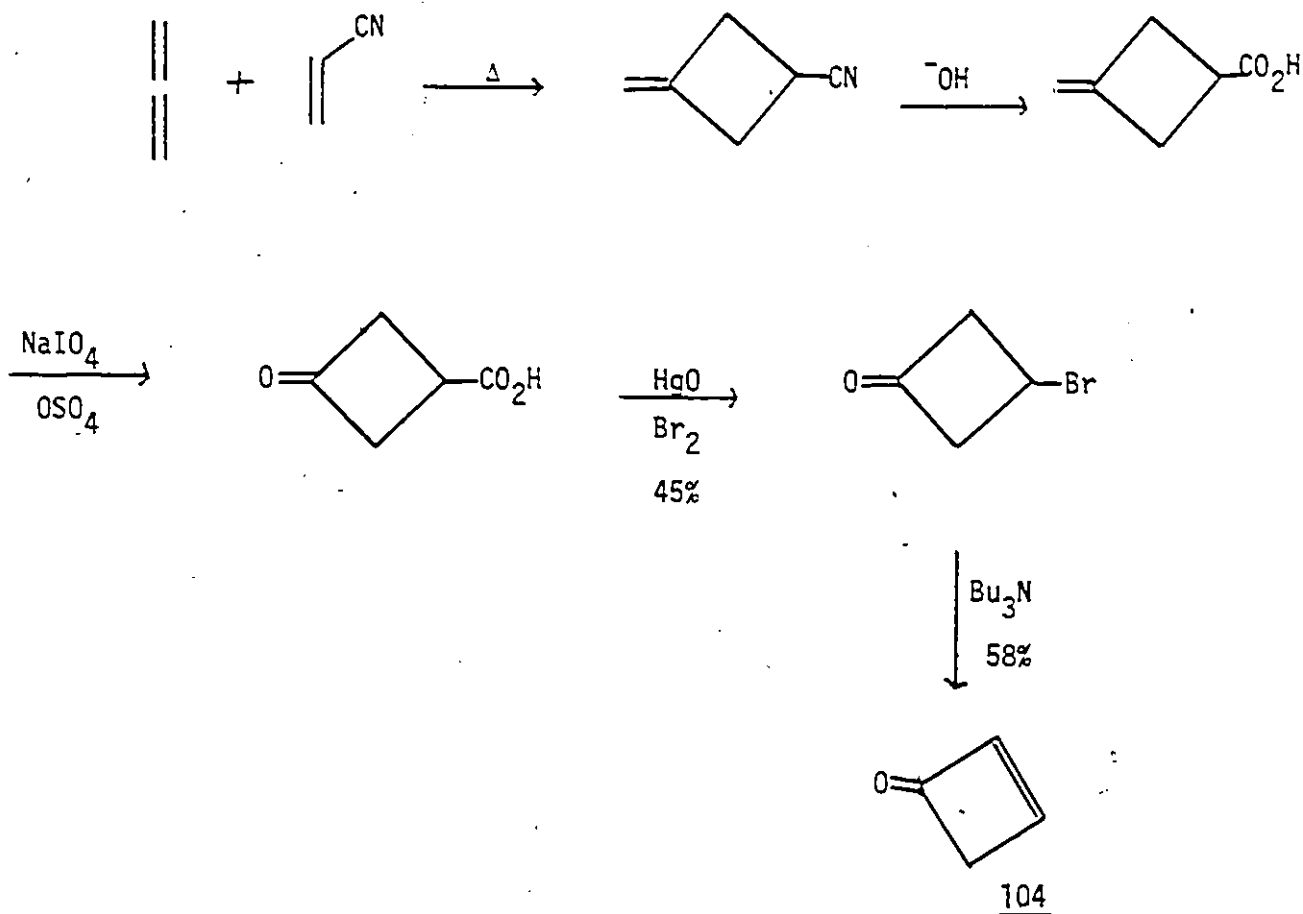

Wasserman and coworkers (47) prepared various 3-substituted

derivatives of 104 by first carrying out a cycloaddition between ketene and ethoxyacetylene to yield 105. The ethoxy group can easily be replaced by the alkyl or aryl group of a Grignard reagent via an addition-elimination sequence.

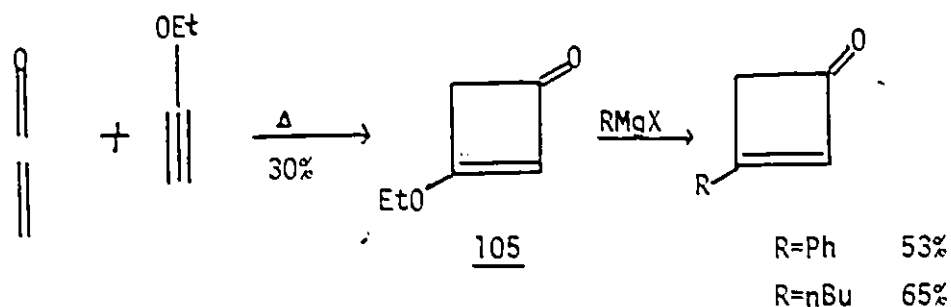

A more recent approach to cyclobutenones has involved the silica catalyzed elimination of alcohols from 3-alkoxy cyclobutenones (48). These 3-alkoxy derivatives 106 were obtained by reaction of ketenes with vinyl ethers.

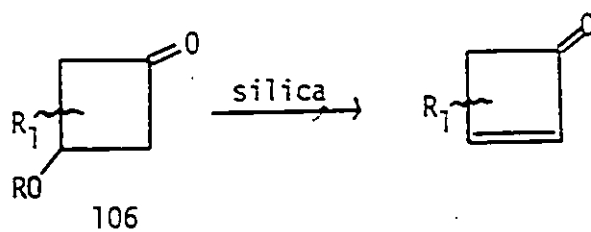

Kelly and McNutt (49) have shown that vinyl sulfides also add to some ketenes. For example, 4,4-dimethyl-3-thiomethyl cyclobutenone 107 was prepared from methyl vinyl sulfide and dimethyl ketene. Subsequent methylation followed by elimination of dimethyl sulfide furnished 4,4-dimethylcyclobutenone 108 in 40% overall yield. (Scheme 15)

Scheme 15

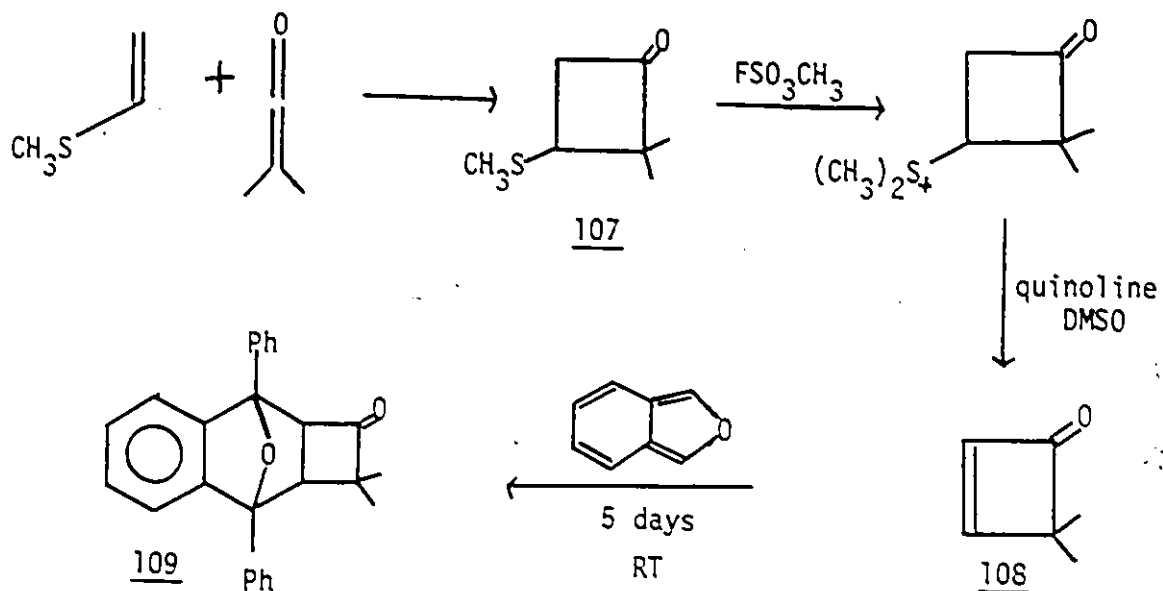

These authors also provided the first demonstration of the Diels-Alder reactivity of a cyclobutenone by trapping **108** with 1,3-diphenylisobenzofuran to give **109** in 62% yield. Trapping of **108** with cyclopentadiene also proceeded in "good" yield but required BF<sub>3</sub>(Et<sub>2</sub>O)<sub>2</sub> catalysis.

Our own attempt to trap the cyclobutenone **110** with trans, trans-hexa-2,4-diene was not successful. The effect of varying reaction conditions and the use of more active dienes was not investigated due to a lack of time.

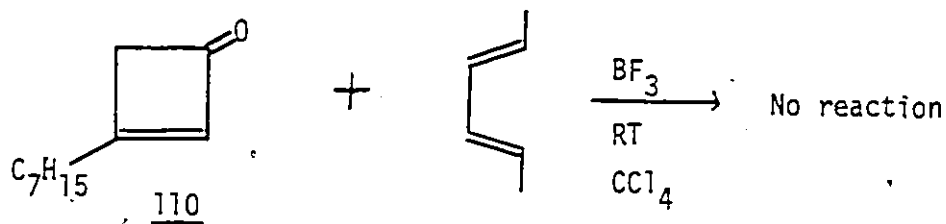

Our route adds significantly to the available synthetic methodology for the synthesis of cyclobutenones, mainly, since an initial cycloaddition reaction to ketenes or allenes is not required.

### Cyclopentenones

Cyclopentenones are accessible via several other routes. The most important of these routes, aldol condensation of  $\gamma$ -diketones, is well described in House's monograph "Modern Synthetic Reactions" (50).

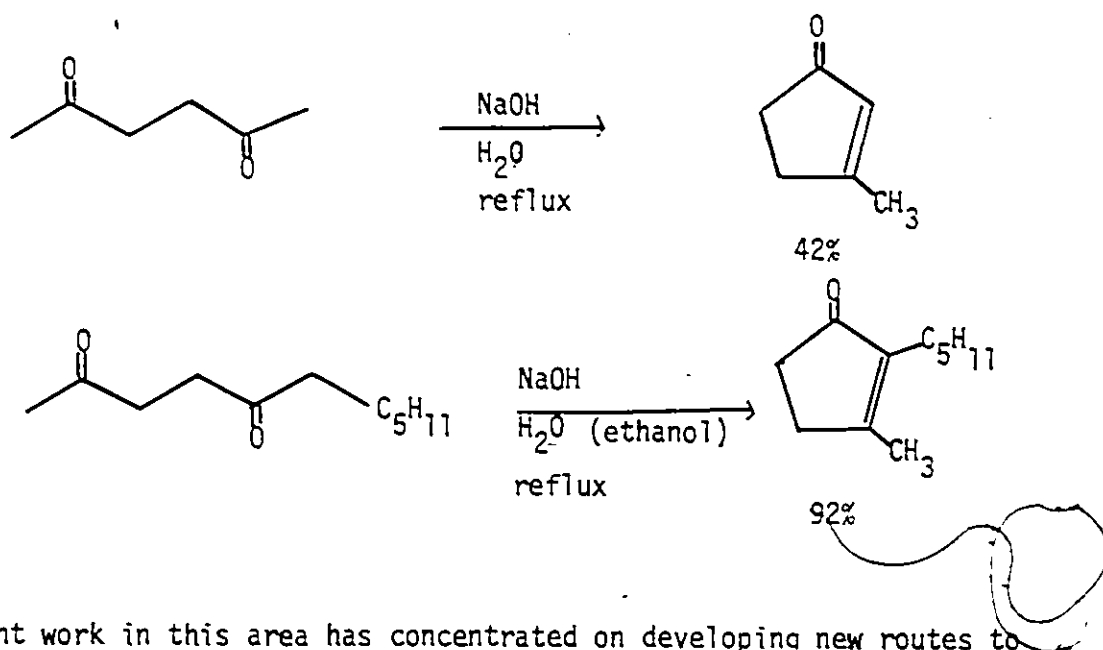

Recent work in this area has concentrated on developing new routes to 1,4 diketones (51).

Another route to 2,3-disubstituted cyclopentenones employing  $\beta$ -epoxy sulfone 111 has recently been reported by Conrad and Fuchs (52).

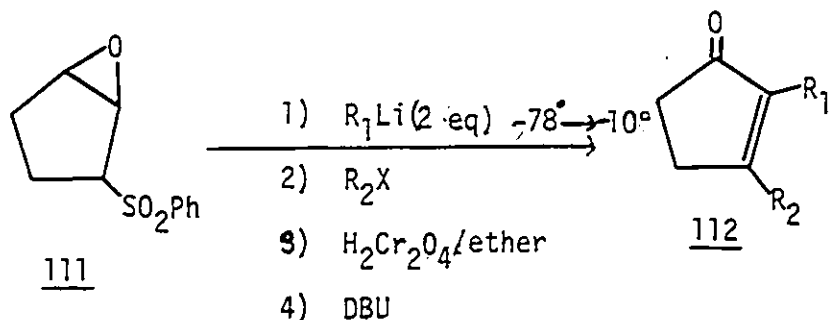

Treatment of the epoxy sulfone 111 with two equivalents of an alkyl lithium results in formation of the dianion 114 via initial conjugate opening of the epoxide followed by Michael addition to the  $\alpha,\beta$ -unsaturated sulfone 113. Addition of an alkylating agent to 114 provides, after quenching, the same types of hydroxy sulfones which we obtained via  $\delta$ -epoxy sulfone cyclization.

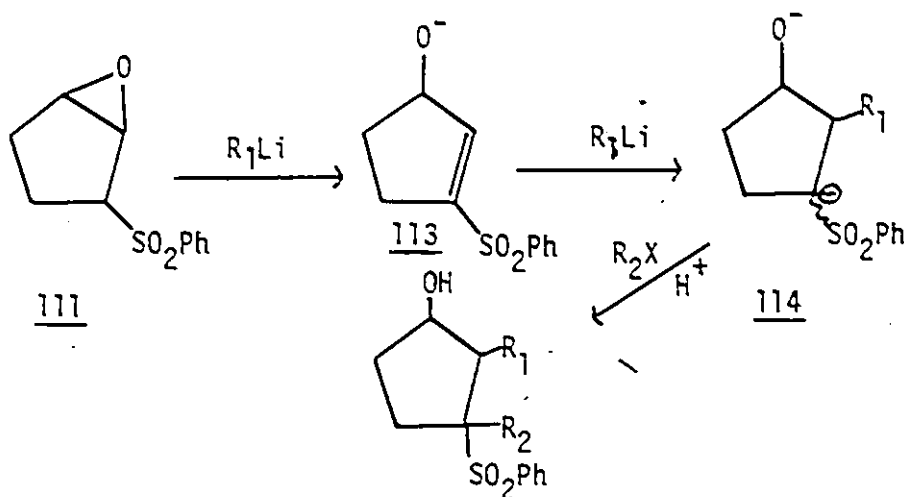

### Attempted Cyclopropene Synthesis

Based on the relative ease of elimination of  $\text{PhSO}_2$  from  $\beta$ -keto sulfones in the four and five-membered ring series we considered the same type of elimination of  $\text{PhSO}_2\text{H}$  from 115 to generate cyclopropenes 116 in which the double bond was conjugated to a carbonyl group.

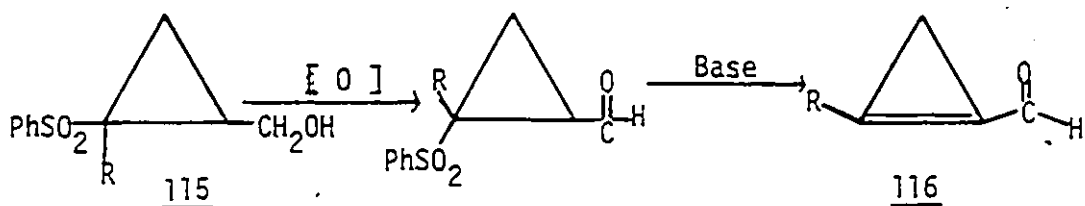

The reactions were to be attempted with systems bearing an alkyl group at C-1. Compounds 115 were considered to be most readily available from 117 by C-alkylation of the dianion 118 similar to that described for the four and five-membered ring series.

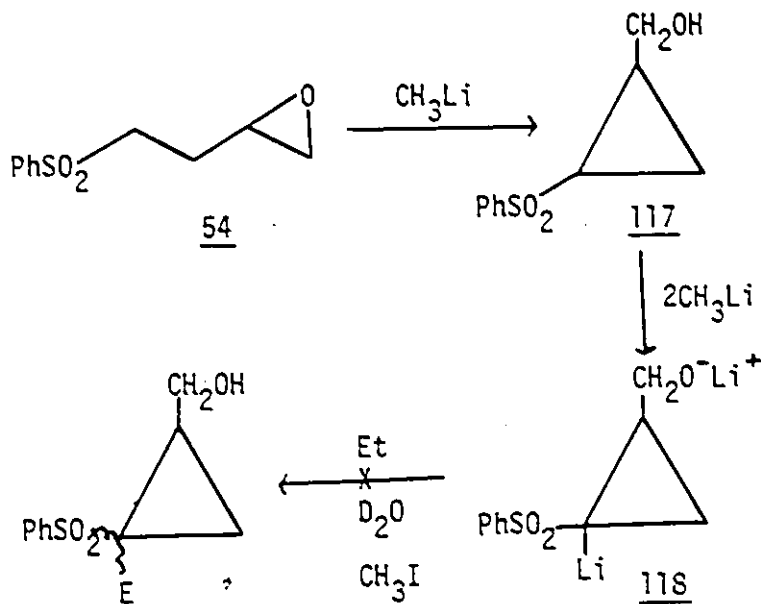

Attempts to generate and trap the dianion 118 of the cyclopropyl sulfone 117 were, however, not successful. The cyclopropyl derivative 117 when treated with two equivalents of  $\text{CH}_3\text{Li}$  at either  $-78^\circ$  or room temperature followed by quenching with  $\text{D}_2\text{O}$  or iodomethane shows no incorporation of either deuterium or a methyl group. A possible explanation for these results may be that the dianion is not formed under our conditions. This is unlikely considering the ease with which cyclopropyl sulfones have been alkylated. For example, Chang and Pinnick (53) obtained excellent yields in alkylations of cyclopropyl phenyl sulfone 119.

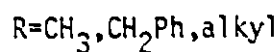
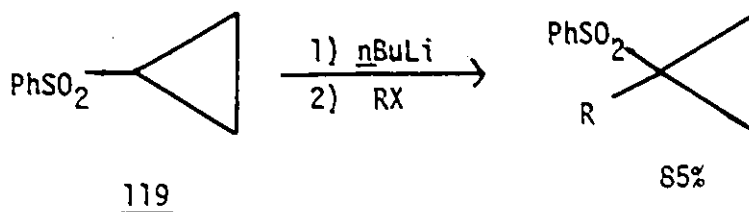

Furthermore, we and others have had no difficulty in alkylating 1,3-dianions of the type shown below.

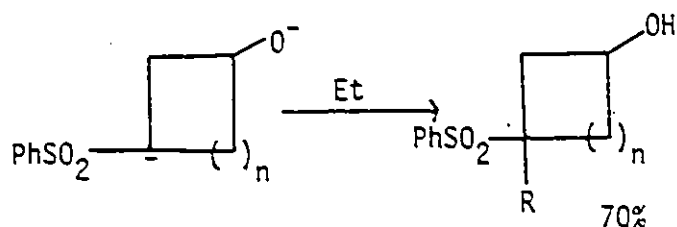

A more plausible explanation is that the dianion 118, once formed, undergoes reaction with the solvent THF thereby generating the alkoxide, olefin and enolate.

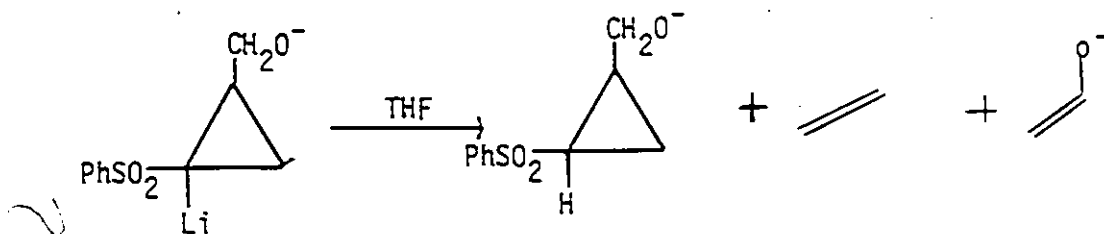

Similar unusual behaviour has been observed by Trost (54) in the case of the related sulfoxide 120. He too was unable to trap the dianion 121 with typical electrophiles such as aldehydes and ketones. It was shown that generation of the dianion 121 in THF-d<sub>8</sub> resulted in formation of the deuterio derivative 122.

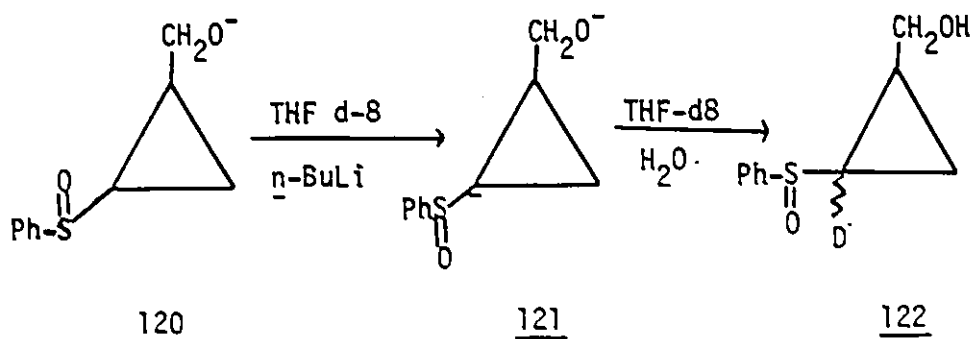

Part B - Cyclobutanols

The preparation of cyclobutanols was carried out according to the Trost (42) procedure. Thus, treatment of the  $\beta$ -phenylsulfonyl cyclobutanols 79 and 123 with excess Na/Hg in "Spectrograde" methanol containing four equivalents of sodium dihydrogen phosphate resulted in the desulfonylated products 124 and 125 in 80 and 85% isolated yields respectively.

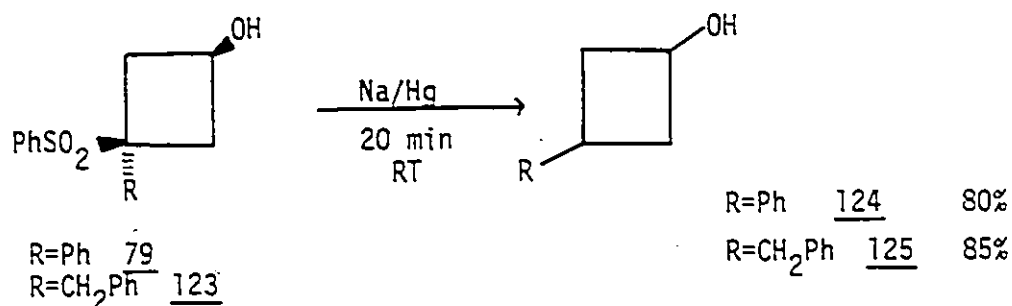

Removal of the phenylsulfonyl group was evidenced by (i) the disappearance of the sulfone bands in the infrared spectra of 124 and 125 and (ii) the loss of the characteristic NMR signals due to the phenylsulfonyl group. Thus, both cyclobutanols showed the hydroxyl band at  $3500\text{ cm}^{-1}$  in their infrared spectra. The 3-phenylcyclobutanol 124 showed NMR peaks at  $\delta 1.7-2.9$  (m, 5H) assignable to the methylene hydrogens and the hydroxyl hydrogen,  $\delta 3.1-3.9$  (m, 1H) and  $\delta 3.9-4.6$  (m, 1H) assignable to the hydrogen at C<sub>3</sub> and C<sub>1</sub> respectively. The aromatic hydrogens at

$\delta$ 7.2 appeared as a slightly broadened singlet.

The benzyl derivative 125 exhibited NMR peaks at  $\delta$ 1.5-2.8 (m, 8H), 4.0-4.7 (m, 1H) and 7.3 (broadened singlet, 1H).

### Stereochemistry and Mechanism

#### Introduction

The preliminary investigations of the mechanism of the Grignard induced epoxy sulfone cyclization, as carried out by Coebel and Durst (32), led to the following proposal for the formation of the cyclobutanols. (Scheme 16)

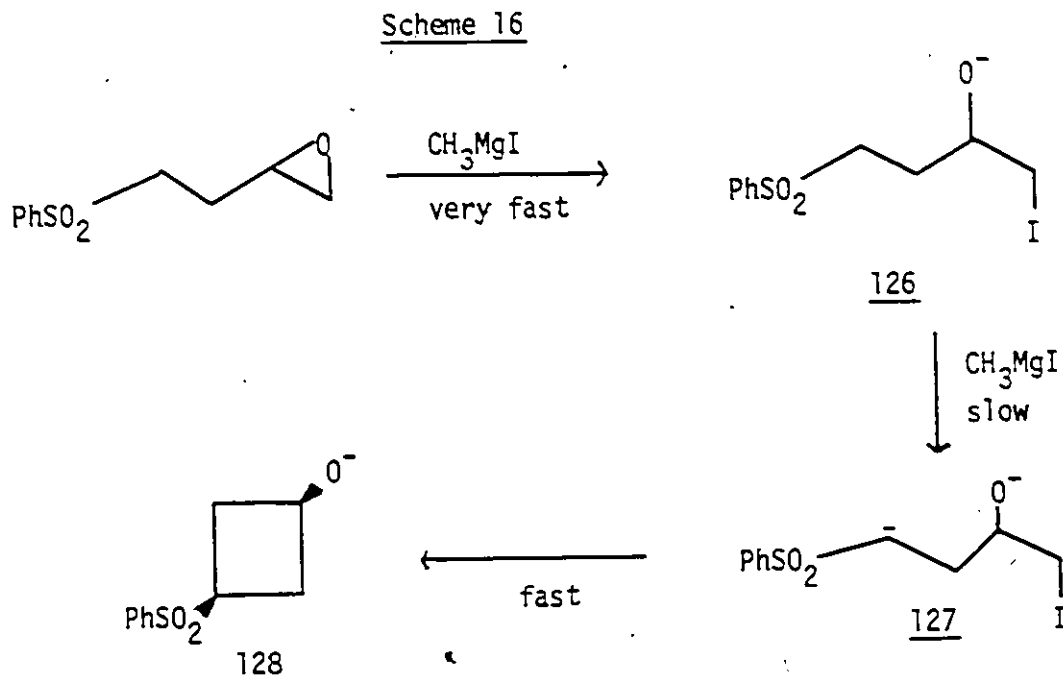

The reaction proceeds by initial opening of the epoxide to the iodoalkoxide 126. This intermediate was isolated as the iodohydrin and subsequently converted to the cyclobutanol by treatment with two equivalents of  $\text{CH}_3\text{MgI}$ . Formation of the alkoxide 126 is followed by proton abstraction

$\alpha$  to the phenylsulfonyl group and subsequent cyclization of 127 and 128. Both the ring opening reaction (55) and  $\alpha$ -sulfonyl Grignard formation (56) have ample literature precedent.

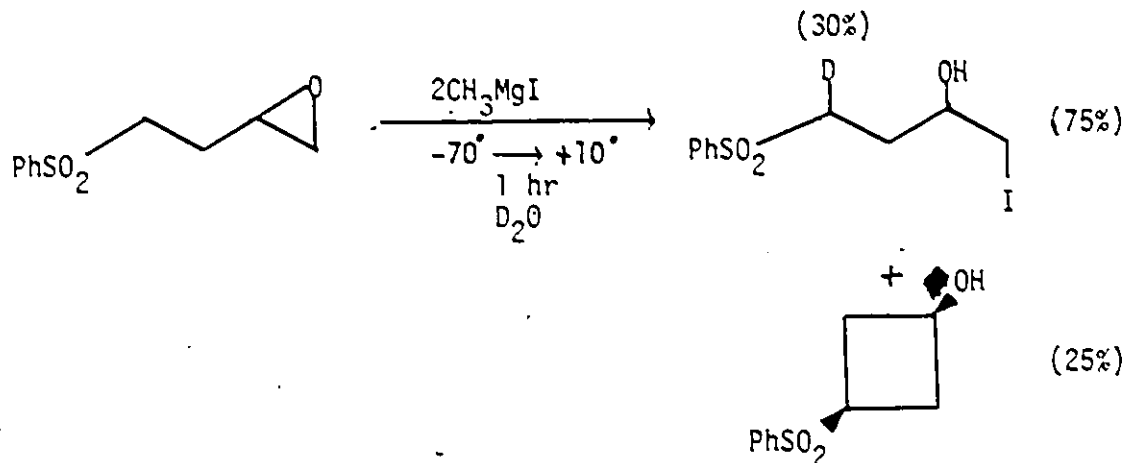

Some evidence for the relative rates of the various steps involved in the cyclization was obtained (32) by quenching the reaction at  $10^\circ$  with  $\text{D}_2\text{O}$ . Deuterium incorporation in the iodohydrin was observed to the extent of 30%, indicating that ring opening of the epoxide is fast relative to  $\alpha$ -sulfonyl Grignard formation. The partial deuterium incorporation suggests that cyclization of the intermediate  $\alpha$ -sulfonyl Grignard reagent is not instantaneous, thus allowing some building of the concentration of 127.

A number of aspects of the cyclization reaction still remained to be investigated, most importantly, the stereochemical course of the cyclization and the necessity of two equivalents of Grignard reagent to affect cyclization.

### Stereochemical Aspects

As was noted earlier only one of the two possible diastereomers was obtained in the cyclization of the epoxy sulfones bearing an alkyl

or aryl substituent  $\alpha$  to the phenylsulfonyl group despite the fact that the starting materials consisted of diastereomeric mixtures. The chiral center  $\alpha$  to the phenylsulfonyl group is eliminated during the course of the cyclization via  $\alpha$ -sulfonyl carbanion epimerization.

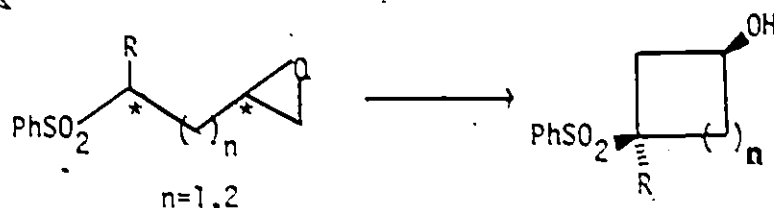

The formation of only one isomer in the case of the  $\alpha$ -substituted derivatives was ascertained by comparing the NMR of both the crude and purified products with that of the diastereomeric mixture prepared by C-alkylation of the parent hydroxysulfones.

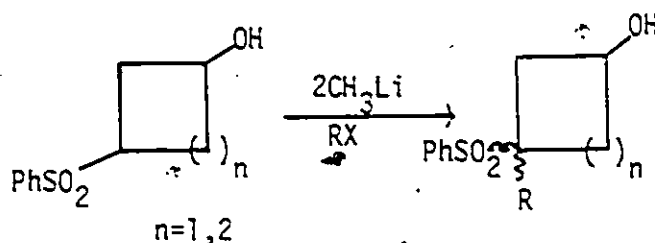

For example, in the case of the cyclobutane 129 obtained via the alkylation route two distinct areas of absorption were observed for  $H_A$  usually in the vicinity of  $\delta 4.0-4.3$  and  $\delta 4.3-4.6$ . The products 130 obtained via cyclization of the  $\alpha$ -substituted derivatives displayed  $H_A$  absorption at  $\delta 4.0-4.3$  with no trace of the other isomer being detected.

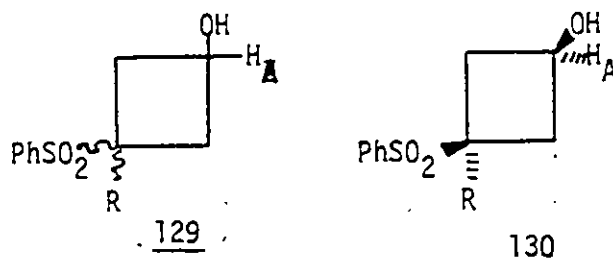

It was also shown that cyclization of  $\delta$ -epoxy sulfones proceeds with high stereospecificity. Thus, alkylation of the parent cyclopentanol with benzyl bromide resulted in the formation of both diastereomers as evidenced by the appearance of two approximately equal intensity singlets for the benzylic hydrogens at  $\delta$ 2.96 and  $\delta$ 3.04. In contrast, cyclization of the epoxy sulfone 60 with two equivalents of  $\text{CH}_3\text{MgI}$  furnished a product 132 which showed  $\text{CH}_2\text{Ph}$  absorption only at  $\delta$ 2.96. No trace of the isomer absorbing at  $\delta$ 3.04 was observed in the crude NMR of the reaction mixture.

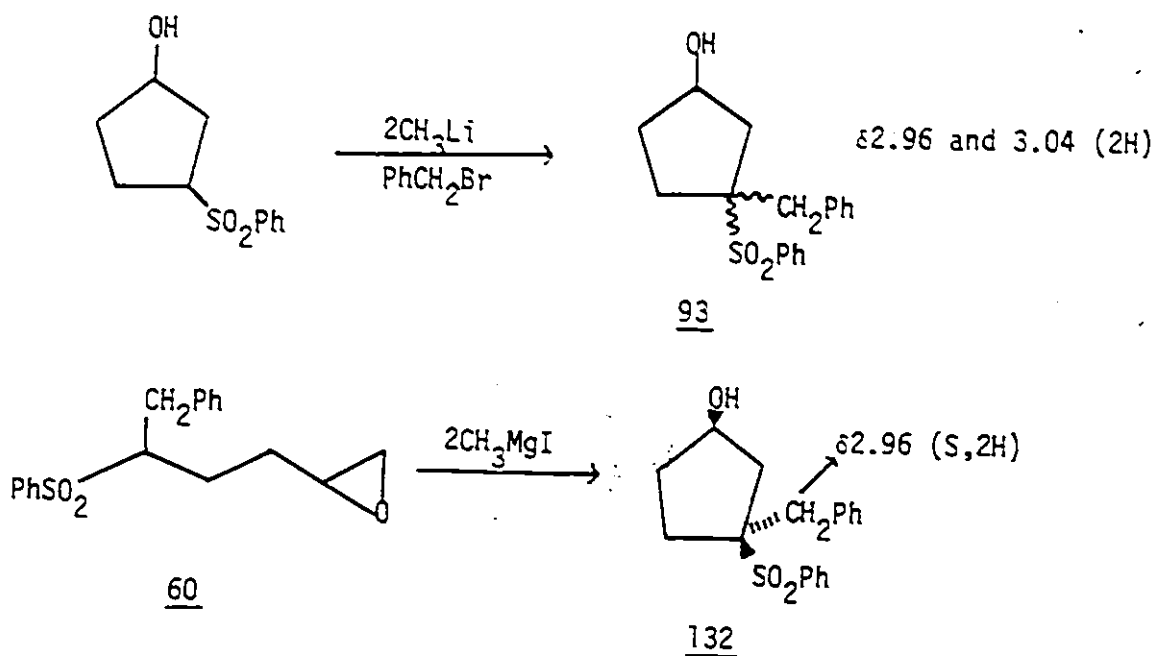

Having thus established the generation of only one diastereomer in the cyclization of  $\alpha$ -substituted  $\gamma$  and  $\delta$ -epoxy sulfones there remained the problem of determining which diastereomer was formed. It was not possible to separate the diastereomeric mixture obtained in the

alkylation reaction, thus pure samples of both diastereomers could not be obtained. This ruled out the possibility of using dipole moment measurements in the determination of the relative configuration of the OH and PhSO<sub>2</sub> groups since pure samples of both isomers are required. The <sup>1</sup>H NMR did not provide any handle on which to base a conclusive assignment of stereochemistry. Two main problems in this area were the overlap of signals and the flexibility of the four-membered ring creating an averaging effect on coupling constants (no fixed dihedral relationships between the various hydrogens).

It was noted that the CH-OH of the cycloalkanols, produced via cyclization of the α-substituted epoxy sulfones, always appeared at lower δ (or upfield) in the <sup>1</sup>H NMR relative to the two areas of absorption observed for CH-OH for the product obtained via alkylation of the parent cycloalkanol (ie. benzyl cyclopentanol discussed above). Thus all CH<sub>3</sub>MgI cyclization products would seem to belong to the same relative stereochemical class. Possibly the observed upfield shift of the CH-OH in the cyclization products may be due to less deshielding of CH-OH in the product having a cis orientation of phenylsulfonyl and hydroxyl groups.

Since a spectral approach to the problem did not seem to be definitive, it was decided to have an X-ray crystal structure determination carried out on one of the crystalline cyclization products.

It proved possible to grow suitable crystals of 79 from methanol and a crystal structure determination was performed by Dr. J. Blount at Hoffmann-LaRoche, Nutley, New Jersey. The relative stereochemistry of 79 as determined by X-ray is that shown below and in Figure 1 with a

Figure 1

Computer Generated Representation of 79 as Determined by X-Ray Crystallography

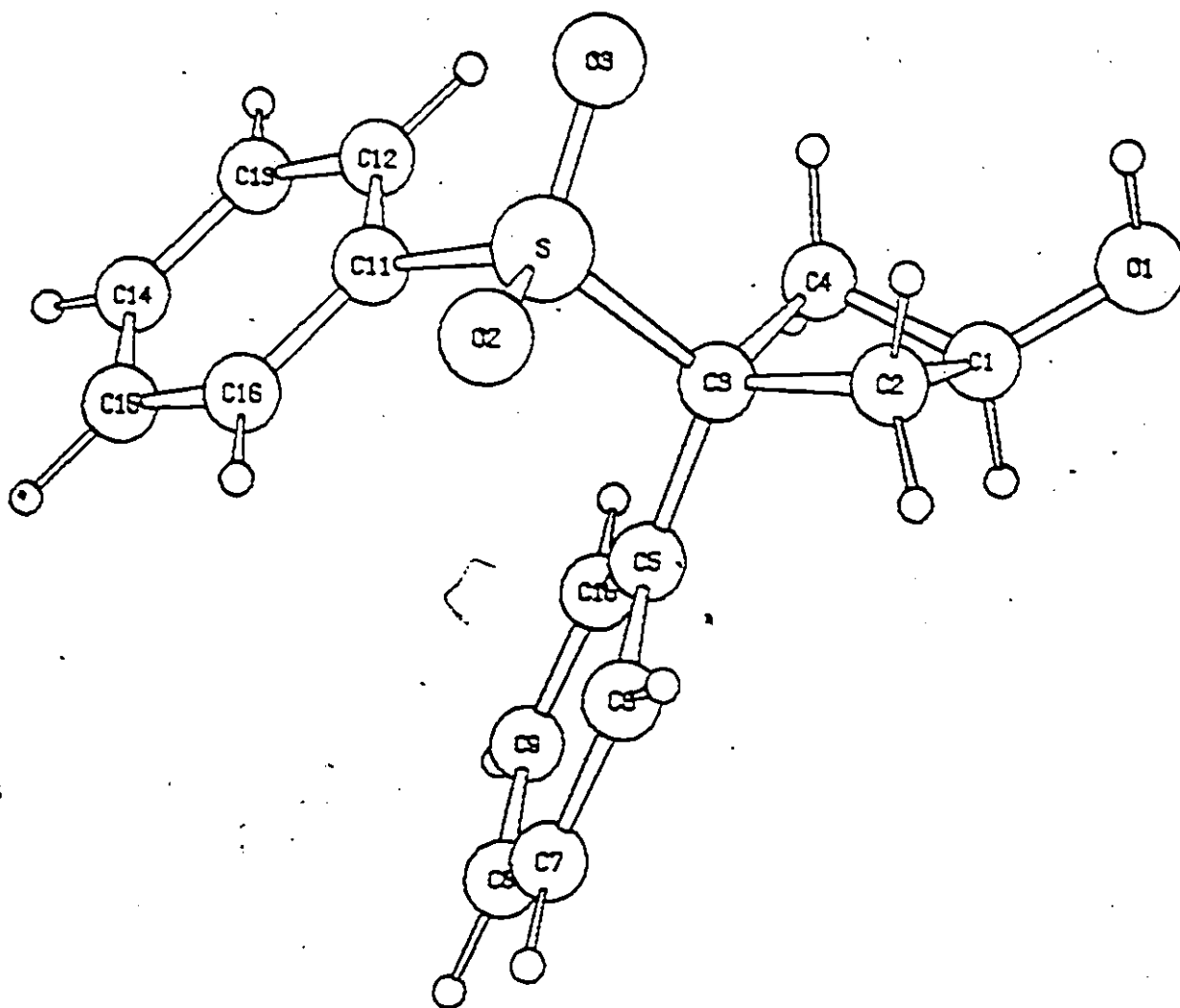

cis arrangement of the phenylsulfonyl and hydroxyl groups.

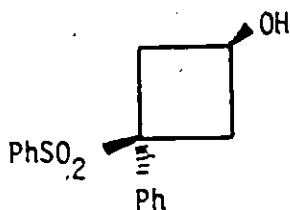

To account for this specificity a complex of the type shown below is suggested to be present during the cyclization.

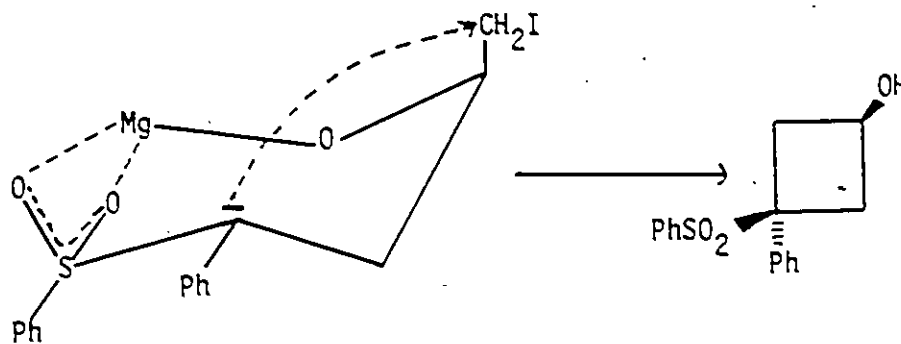

The alkoxide oxygen and the sulfone group are disposed in a cis orientation due to chelation by the magnesium cation. The iodomethyl group is required to be in a pseudo-axial position for backside attack by the  $\alpha$ -sulfonyl carbanion.

Even though sulfone oxygens are not very basic, it is suggested that  $\alpha$ -sulfonyl carbanion formation enhances the basic character of the sulfone oxygens to such an extent that coordination to the magnesium cation is more feasible.

This increased oxygen basicity upon  $\alpha$ -carbanion formation is supported by the work of Marquet (57) who observed a  $60\text{ cm}^{-1}$  lowering of both SO<sub>2</sub> bands in the infrared spectra PhSO<sub>2</sub>CH<sub>2</sub>Li vs. PhSO<sub>2</sub>CH<sub>3</sub>. This

result suggests that the sulfur-oxygen bonds have taken on more single bond character with partial dispersion of the negative charge onto the sulfone oxygens. The sulfone bands in infrared spectra usually occur at  $1310\text{-}1350\text{ cm}^{-1}$  and  $1120\text{-}1160\text{ cm}^{-1}$  whereas the S=O stretching frequency in sulfoxides, compounds in which the S-O bond is high dipolar and capable of acting as an H-bond acceptor, occurs around  $1040\text{-}1060\text{ cm}^{-1}$ .

It was thought that the importance of the chelation in controlling the stereochemical outcome of the cyclization might be tested by O-alkylation of the intermediate haloalkoxide, thereby reducing the strong -O- Mg interaction. To this end, the protected bromohydrin 135 was prepared as shown below.

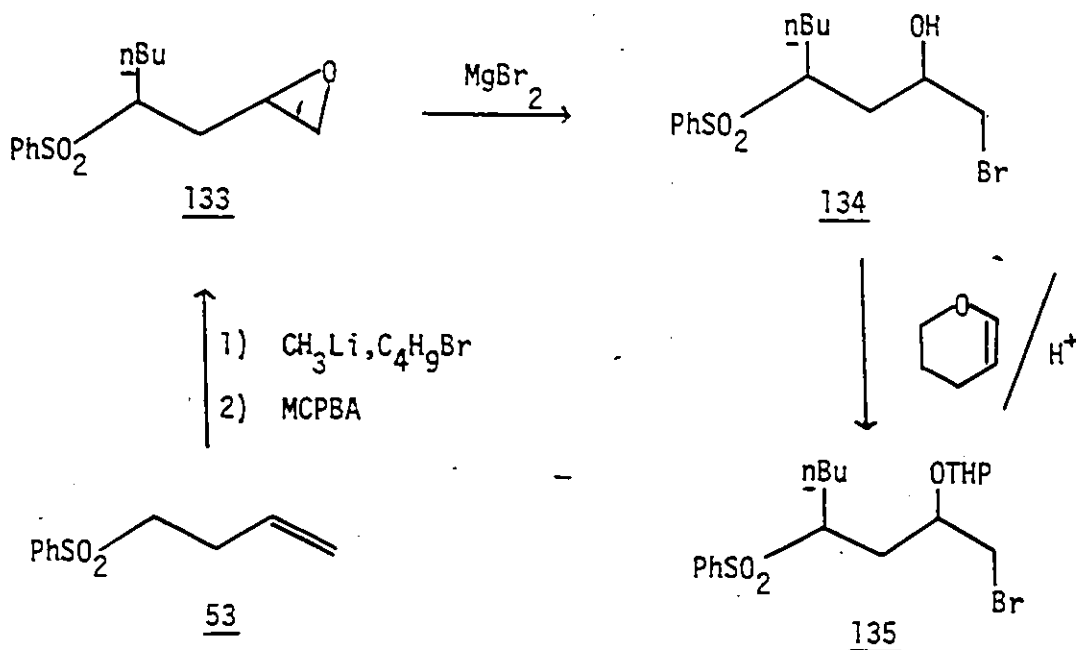

Treatment of 135 with  $\text{CH}_3\text{MgI}$  was then expected to give the corresponding cyclobutane derivative possibly as a mixture of diastereomers, which after removal of the THP group, could be compared to 137 of known stereochemistry.

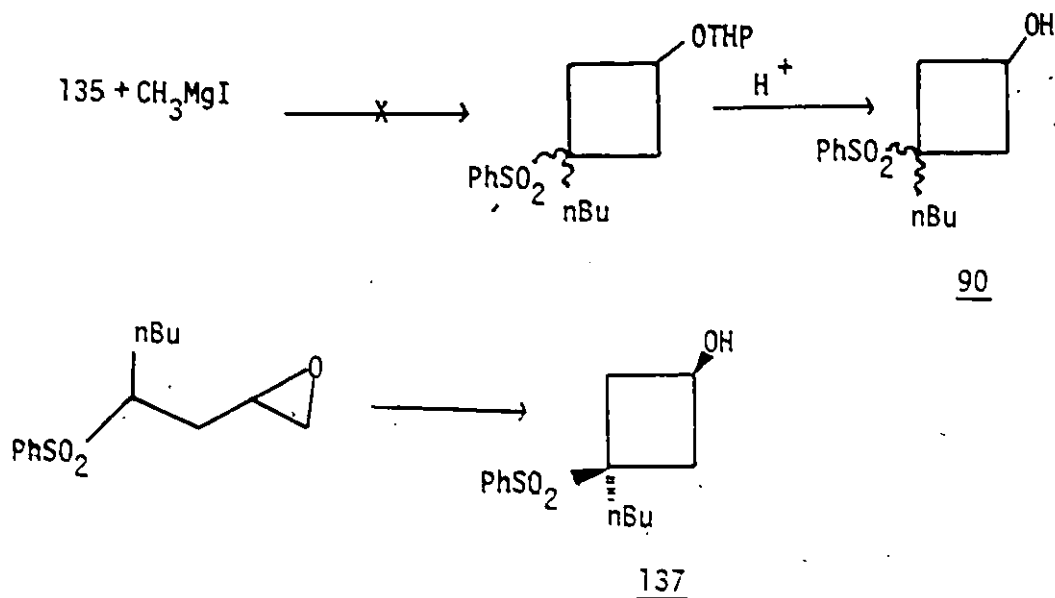

However, under a variety of reaction conditions (1,2.5,3 equivalents of CH<sub>3</sub>MgI, reaction times of 12 hrs. to 7 days) the only observed products were starting material and the corresponding iodide formed via bromide-iodide exchange.

This result was quite unexpected. One possible explanation for the reluctance of the THP derivative 135 to undergo cyclization may be increased steric congestion about the reaction centre. In order to reduce this aspect, cyclization of the THP derivative of 138 was attempted. Once again, no cyclization product was observed and only the starting material 139 was recovered after hydrolysis. Hydrolysis of the reaction product with HCl/MeOH resulted in an 80% recovery of the iodohydrin 138.

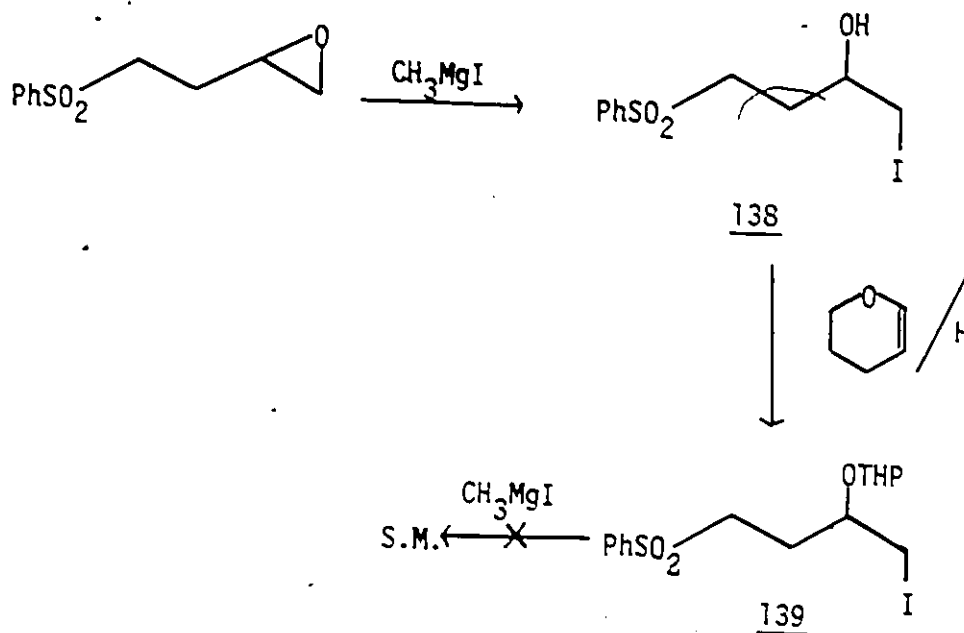

In order to rule out in situ quenching of the Grignard reagent one reaction trial was quenched with benzophenone after twenty four hours. Chromatography of the reaction mixture gave starting material (90%) and an 85% yield of 1,1-diphenylethanol.

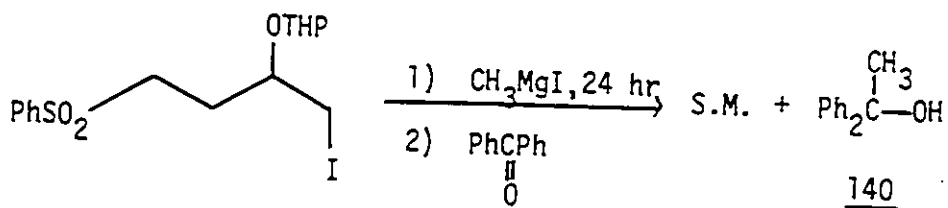

It was possible to show that the presence of the hydroxyl group is not essential in the cyclization reaction since 4-iodobutyl sulfone was readily converted into cyclobutyl phenyl sulfone upon treatment with  $\text{CH}_3\text{MgI}$  (see below). Thus, one is left with the conclusion that THP derivatives of 135 and 139 do not readily cyclize due to steric reasons. Consequently we were unable to obtain

experimental evidence for our earlier suggestion of a chelate complex in the cyclization reaction.

### Synthesis of Cyclobutyl Phenyl Sulfone

The required bromosulfone 141 was prepared in 18% yield by reaction of sodium phenylsulfinate with excess dibromobutane in absolute ethanol.

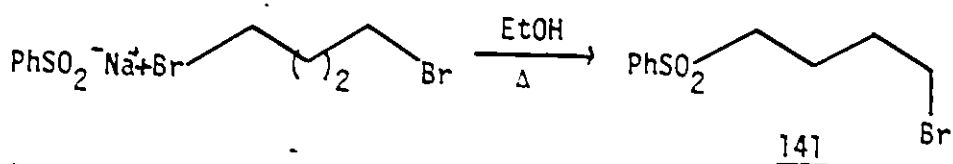

Treatment of 141 with one equivalent of  $\text{CH}_3\text{MgI}$  for twelve hours at room temperature followed by quenching with a saturated ammonium chloride solution resulted in the product distribution (determined by NMR) shown below.

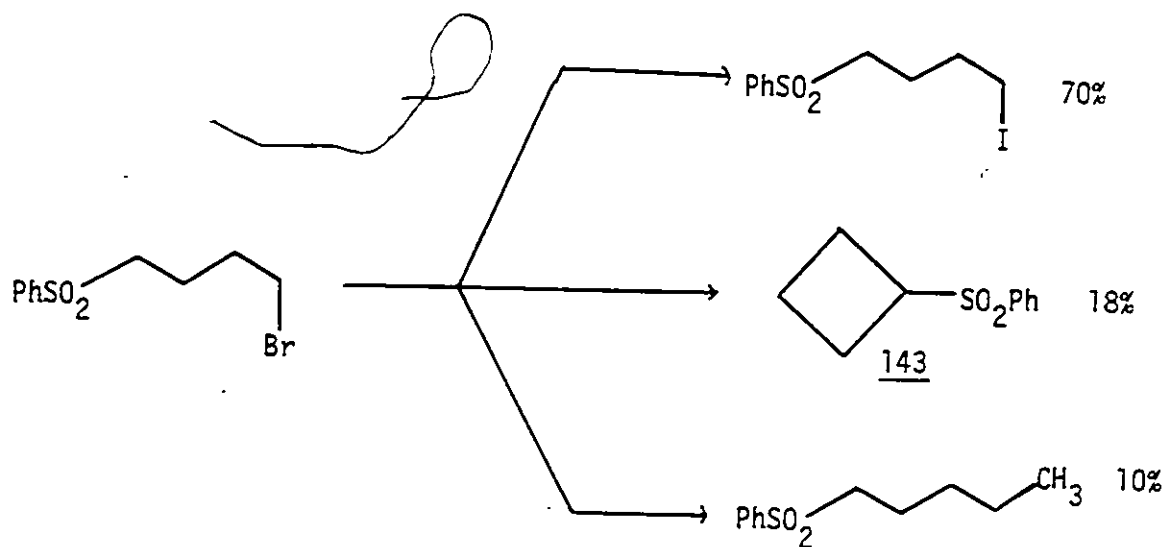

Formation of 142 occurs via halide exchange between iodide and bromide. Recrystallization of the crude reaction mixture furnished a pure sample of the iodosulfone 142 which was identical in all respects to an authentic sample prepared by reaction of 141 with sodium iodide.

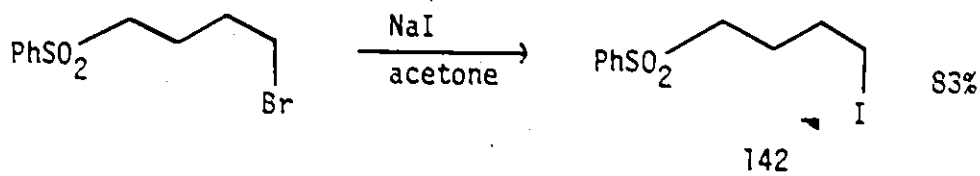

The cyclobutyl sulfone 143 arises by intramolecular displacement of halide ion by the  $\alpha$ -sulfonyl carbanion of 141 or 142.

The 1-phenylsulfonyl pentane 144 results from displacement of halide ion by the methyl group of the Grignard reagent.

Reaction of the iodosulfone 142 with one equivalent of  $\text{CH}_3\text{MgI}$  for twenty four hours at room temperature yielded a mixture of 143, 142 and 144 in 45, 45, and 10% yields respectively.

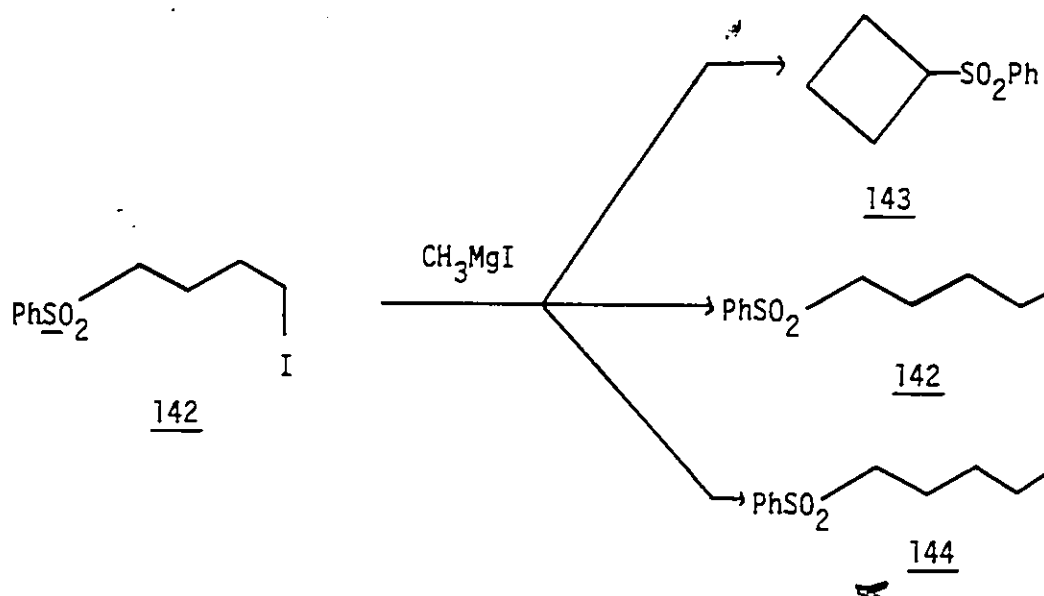

With two equivalents of  $\text{CH}_3\text{MgI}$  at room temperature for twenty four hours 142 furnishes the cyclobutyl sulfone 143 in 90% yield. Thus the coupling of  $\text{CH}_3\text{MgI}$  with 142 to yield 144 is not competitive with ring formation when two equivalents of  $\text{CH}_3\text{MgI}$  were used.

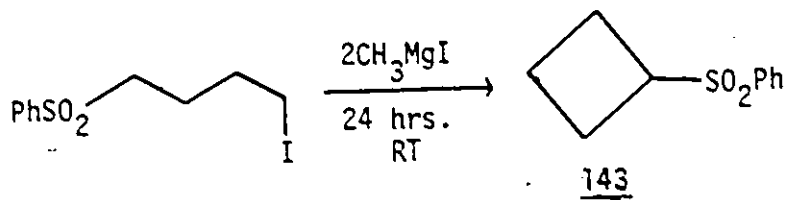

#### Base Requirements of Epoxy Sulfone Cyclization

The cyclization of epoxy sulfones was found to require two equivalents of Grignard reagent. This conclusion was drawn from a study of the reaction of the epoxy sulfone 54, in parallel runs, with one and two equivalents of Grignard reagent, respectively.

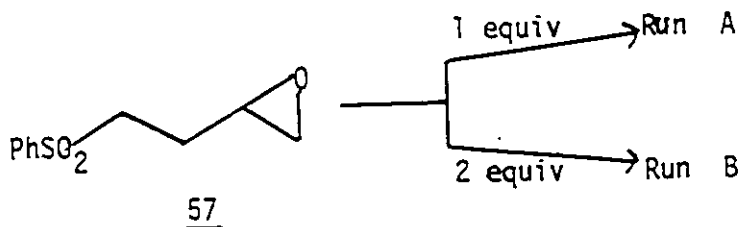

The Grignard reagent was standardized immediately before use. The two reactions were run in THF under nitrogen. The addition of the Grignard reagent was carried out at  $-78^\circ$  and the reactions were allowed to warm to room temperature. Aliquots (1 ml) were taken via syringe at various time intervals. The one ml aliquots were quenched with saturated ammonium chloride solution and extracted with 20 ml of ether. Drying and evaporation of the organic phase furnished a material which was

examined by  $^1\text{H}$  NMR. The results are presented in Table VI. The only product observed in Run A (one equivalent) after 52 hrs. was the iodohydrin, whereas in Run B (2 equivalents) cyclization was complete in twenty five hrs. as determined by  $^1\text{H}$  NMR. Upon quenching the reaction mixture gas evolution was observed in both cases, indicating that active Grignard reagent remained in both cases.

The requirement of two equivalents of Grignard reagent may be rationalized in the following manner. Reaction of the epoxy sulfone 54 with one equivalent of  $\text{CH}_3\text{MgI}$  initially furnishes the intermediate 145.

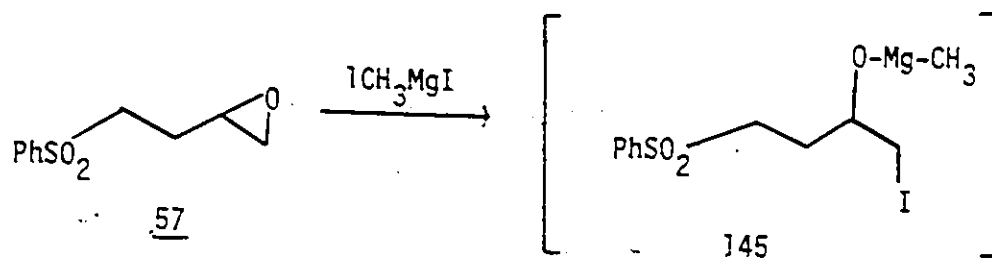

Cyclization of the intermediate 145 requires proton abstraction,  $\alpha$  to the phenylsulfonyl group, by a methylmagnesium species present in solution. It is suggested that this key step is hampered by the decreased basicity of the methyl group due to coordination of the magnesium to the oxygen. Replacement of iodine by oxygen results in greater positive character being instilled on the magnesium (i.e. electronegativity of oxygen (3.5) vs iodine (2.5)). This in turn strengthens the  $\text{Mg-CH}_3$  bond thus reducing the basic character of the methyl group.

TABLE VI  
Base Requirement of Epoxy Sulfone Cyclization

<u>Time(hr)</u>	<u>Run</u>	<u>%S.M.</u>	<u>%iodohydrin</u>	<u>%cyclobutanol</u>
1.5	A*	70	30	
	B**	< 5	> 95	
4	A		> 95	< 5
	B		75	25
26	A		> 95	< 5
	B		< 5	> 95
52	A		> 95	< 5
	B		< 5	> 95

A\* (one equivalent of  $\text{CH}_3\text{MgI}$ )

B\*\* (two equivalents of  $\text{CH}_3\text{MgI}$ )

Above values are approximate

Conclusions Regarding Epoxy Sulfone Cyclizations

$\gamma$ -Epoxy Sulfones - Cyclobutanols

The mechanism for the formation of cyclobutanols from  $\gamma$ -epoxy sulfones has been discussed previously. This conversion may be summarized as follows.

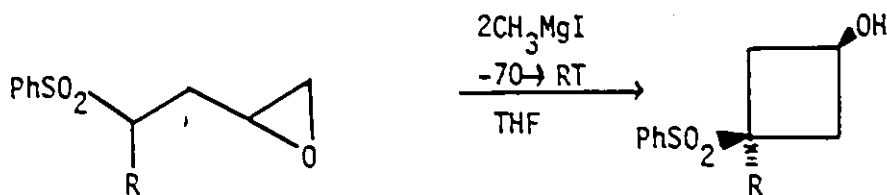

$\gamma$ -Epoxy Sulfones - Cyclopropyl Methanols

As was mentioned previously Corbel showed that  $\gamma$ -epoxy sulfones which are substituted at the terminal position give cyclopropyl derivatives when treated with  $\text{CH}_3\text{MgI}$ . This divergent behaviour is easily rationalized on the basis of Scheme 17.

Scheme 17

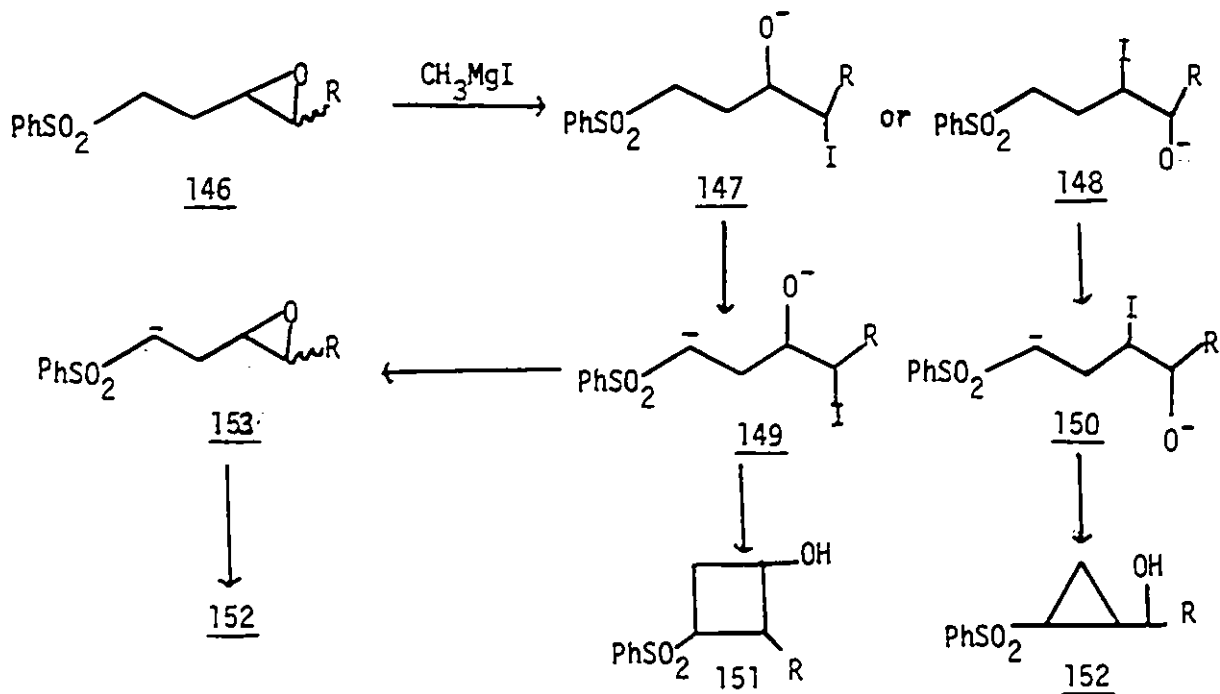

The ring opening of 146, in contrast to that of 54 (R=H) would not be expected to be highly regioselective and thus results in the formation of both alkoxides 147 and 148. Grignard formation from these species results in 149 and 150 respectively. Cyclization of 150 and 152 is known to be much faster than that of 149 to 151, thus allowing the possibility of generating the epoxide 153 which can then cyclize to 152. Durst and Corbel showed the feasibility of such a type of scheme by generating the iodohydrin related to 149 (R=Ph) and showing that under typical treatment with  $\text{CH}_3\text{MgI}$ , only the cyclopropyl sulfone 152 (R=Ph) was obtained.

#### $\delta$ -Epoxy Sulfones - Cyclopentanols

It was observed that  $\delta$ -epoxy sulfones form only 3-phenylsulfonyl cyclopentanols upon reaction with  $\text{CH}_3\text{MgI}$ , irrespective of the substitution pattern about the epoxide. A scheme similar to that above, which explained the preferential formation of 152 from 146 suggests that of the two possible ring opened intermediates 154 and 155, cyclization of the former, which results in the formation of a five-membered ring should be kinetically preferred. Intermediate 155 can recyclize to the initial epoxide and re-open again to 154 and hence 156.

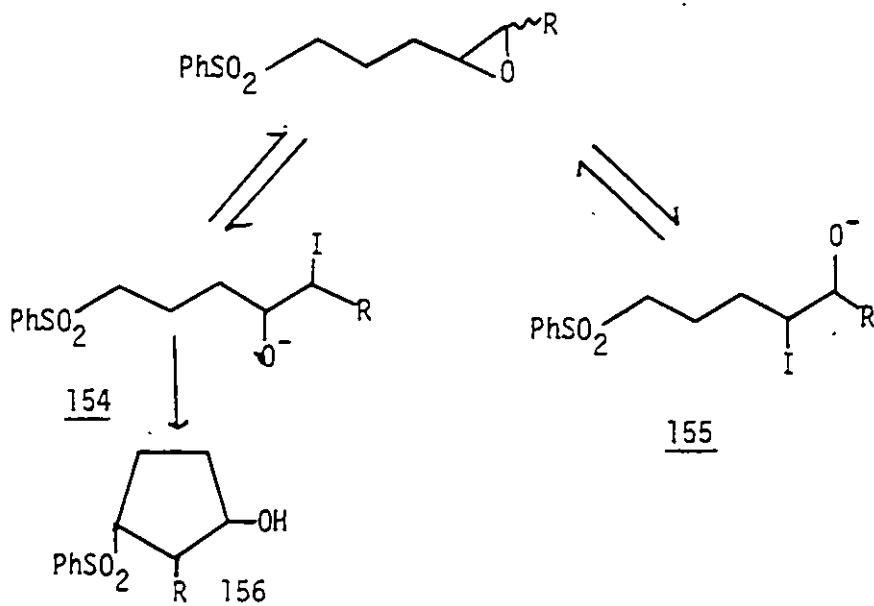

Grignard Induced Cyclization of  
Epoxy Nitriles and Epoxy Phosphine Oxides

The  $\text{CH}_3\text{MgI}$  induced cyclization of epoxy sulfones can also be applied to Stork's epoxy nitriles and to a limited extent to epoxy phosphine oxides.

Stork (8) had shown that  $\gamma$ -epoxy nitriles, when treated with LDA, furnished cyclopropyl derivatives. No mention was made of the yields in such reactions.

The cyclization of  $\gamma$ -epoxy nitriles was subsequently reinvestigated by Corbel and Durst (32). These authors found, in agreement with Stork's results, that cyclopropane derivatives are the only cyclic products obtained from reaction of  $\gamma$ -epoxy nitriles with LDA. The cyclopropyl derivatives were obtained in yields of 43-94%.

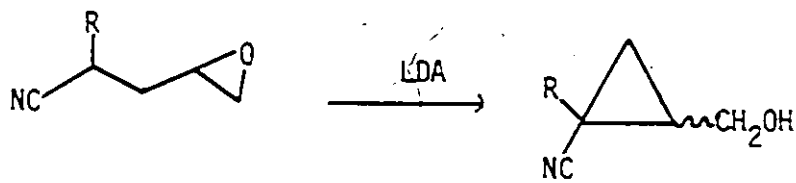

R=Ph	94%
R=C <sub>6</sub> H <sub>13</sub>	43%
R=H	59%

Treatment of the same starting materials 157 with two equivalents of  $\text{CH}_3\text{MgI}$  resulted in the formation of 3-cyanocyclobutanol 158 in yields of 40-70%. A similar cyclization of the  $\delta$ -epoxy nitrile 160 gave 3-cyano-3-phenylcyclobutanol 161 in 80% yield.

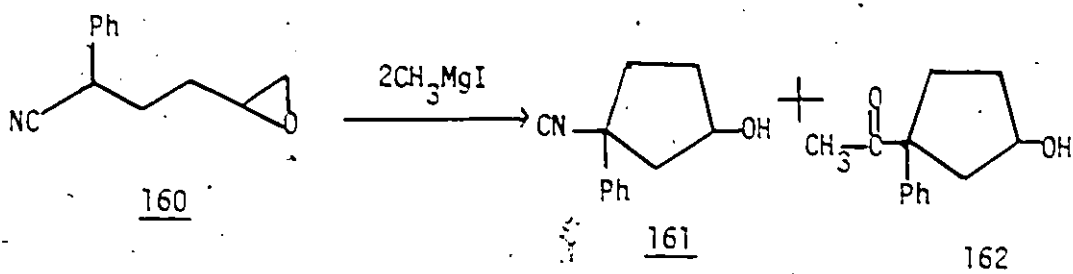
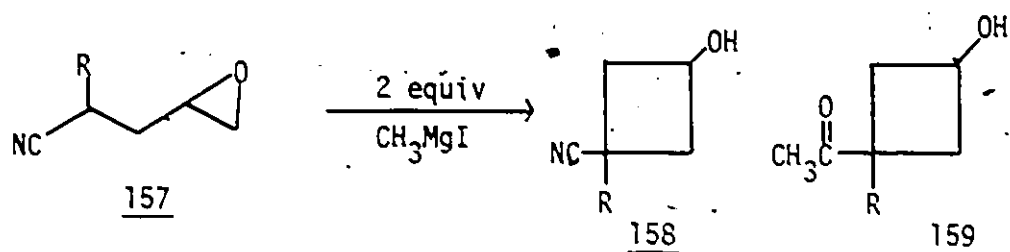

In the epoxy nitrile series the amount of Grignard reagent employed is more crucial than for epoxy sulfones where excess Grignard reagent does not produce undesirable side products. In fact, both the cyclobutyl and cyclopentyl nitriles 158 and 161 were contaminated with about 10% of the corresponding methyl ketones 159 and 162, the result of further reaction of the nitrile alkoxide with excess  $CH_3MgI$ . Grignard addition to the nitrile must occur after cyclization to 163 since formation of a dianion from 164 is not possible with the Grignard reagent as base. It is somewhat surprising that addition of the Grignard reagent to the nitrile is much slower than  $\alpha$ -carbanion formation and subsequent cyclization to the cycloalkanol. As in the case of the

epoxy sulfones one isomer is formed with high stereoselectivity in the cyclization of both  $\gamma$  and  $\delta$ -epoxy nitriles.

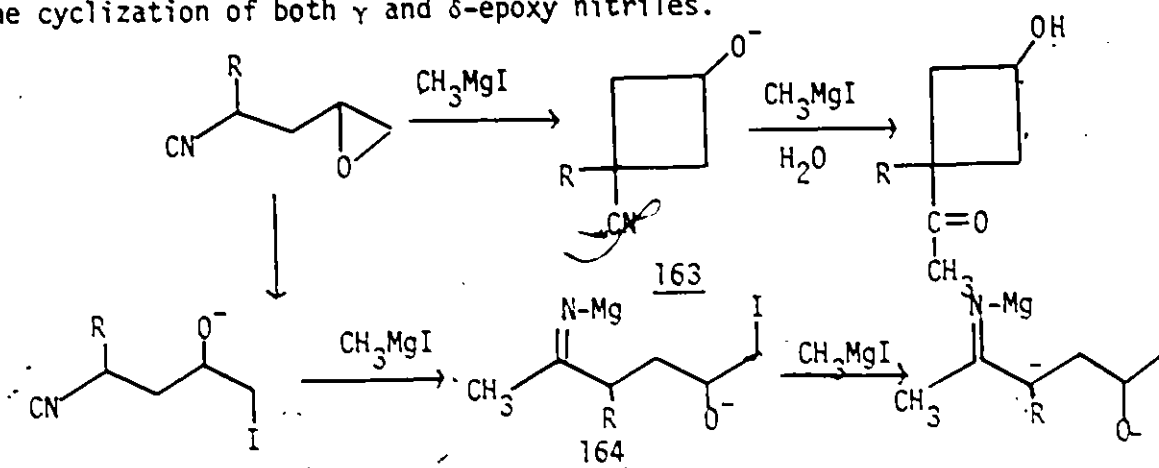

The formation of the keto alcohols is best avoided by first opening the epoxide ring with  $\text{MgBr}_2$  and then adding one equivalent of  $\text{CH}_3\text{MgI}$ . Such a procedure yields optimum amounts of the desired cyclobutyl nitriles. For example, the cyclobutyl derivative 166 was obtained in 80% yield from the epoxy nitrile 165 by this approach.

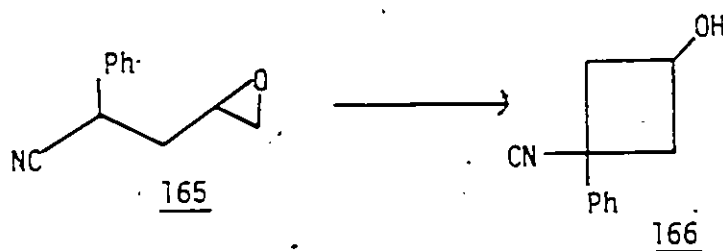

If the 3-acetyl derivatives are the desired product they can best be obtained by reaction of the epoxy nitriles with about four equivalents of  $\text{CH}_3\text{MgI}$ .

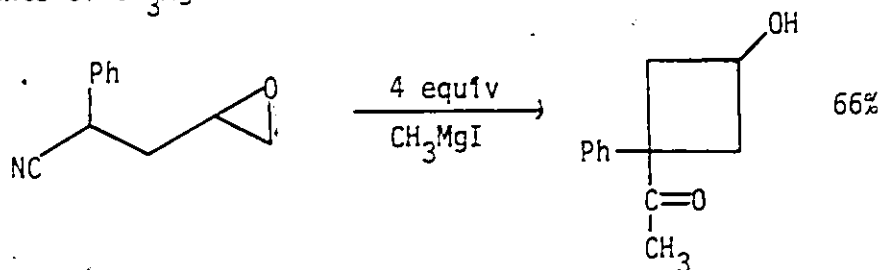

The above findings of Corbel and Durst greatly add to the value of  $\gamma$ -epoxy nitriles since they can be converted into either three or four-membered ring products depending on the base employed.

### Epoxy Phosphine Oxides

Treatment of the  $\gamma$ -epoxy phosphine oxide 167 was shown by Corbel (68) to provide the expected cyclopropane derivative 168. The cyclobutanol derivative 169 was obtained by treatment of 167 with  $\text{CH}_3\text{MgI}$ . This provides an example, though limited, of a functional group which is compatible with the conditions employed in the Grignard reaction. With  $\text{R}=\text{alkyl}$  in this series no cyclization took place presumably because of the inability of  $\text{CH}_3\text{MgI}$  to form  $\alpha$ -phosphine oxide carbanions from 167 unless  $\text{R}=\text{Ph}$ .

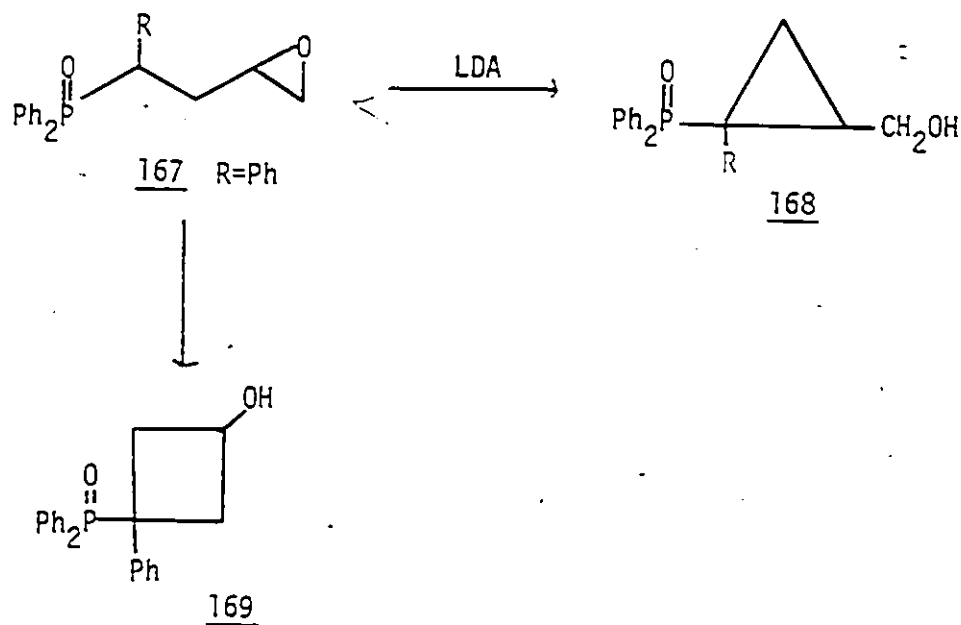

PART II

OXIDATION OF SULFUR-STABILIZED CARBANIONS

## INTRODUCTION

The reaction of organolithium compounds with molecular oxygen has been long known. For example, alkyllithiums (methylithium, phenyllithium) oxidize so energetically in air that spontaneous ignition occurs. Muller and Toppel (1) obtained, after hydrolysis, a 75% yield of n-butyl alcohol by the reaction of n-butyl lithium with oxygen diluted with nitrogen.

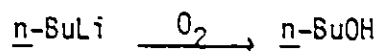

Recent efforts in this field have been largely devoted to the oxidation of lithio carbanions adjacent to electron withdrawing groups. Such a process can lead to  $\alpha$ -hydroxy or hydroperoxy derivatives. The electron withdrawing groups which have been found to be compatible with the above process will be briefly described.

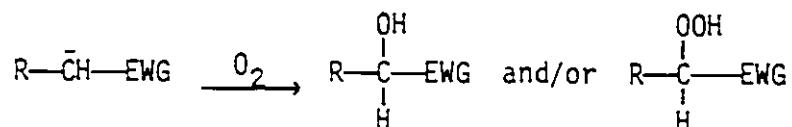

### Carboxylic Acids and Esters

It was found by Konen et al (2) and others (3,4) that treatment of esters 1 with LDA followed by introduction of  $\text{O}_2$  resulted in the formation of hydroperoxy esters 2 in yields of 40-70%.

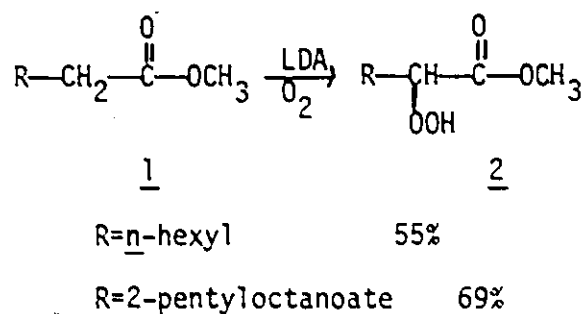

The major side products were the corresponding 2-hydroxy derivatives.

These authors also studied the reactions of dianions of carboxylic acids 3 with  $\text{O}_2$  and obtained hydroperoxides 4 in about 30% yield. Such compounds 4 are important biological intermediates. The low yields of 4 were due to carbanion reduction of the intermediate peroxide 5 thus giving 6.

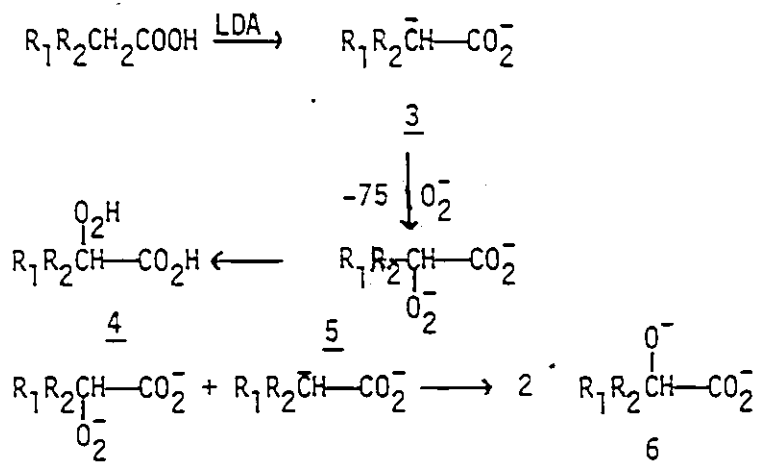

This competitive reduction could be minimized by inverse addition of the carbanion to ether saturated with  $\text{O}_2$ . This procedure improved the yields of the hydroperoxides to about 60%.

The 2-hydroxy acids or esters could be made the major products by carrying out the oxygenation at  $25^\circ$  rather than  $-78^\circ$ . These

conditions afforded a 90% yield of products consisting of an 85/15 ratio of 2-hydroxy to 2-hydroperoxy derivatives.

### Nitriles

It has been demonstrated (5) that the carbanion generated next to the nitrile function is susceptible to oxidation by molecular oxygen. The carbanion 8 was generated by reaction of the nitrile 7 with LDA. Introduction of  $O_2$  into the reaction mixture resulted in formation of the intermediate peroxy derivative 9. The presence of this intermediate was verified by quenching 9 with aqueous acid or acetyl chloride and subsequent isolation of the  $\alpha$ -hydroperoxy nitrile 10a or the acetate 10b, respectively. Reduction of 10 with an acidic  $SnCl_2$  solution gave the cyanohydrin 11 which on subsequent exposure to aqueous NaOH afforded the ketone 12. For example, 7 ( $R_1=CH_2Ph, R_2=CH_3$ ) was converted to 10a, 11 and 12 in isolated yields of 92, 89 and 98%, respectively (Scheme 1).

The above methods, which represents the conversion of a nitrile,  $R_1R_2CHCN$ , to a ketone  $R_1R_2C=O$ , having one less carbon, was found to be applicable to dialkyl, diaryl and alkyl and nitriles. The overall yields ranged between 65 and 90%.

In contrast to the above examples, primary nitriles were oxidized to aldehydes in relatively low yields. The low yields were ascribed to formation of carboxylic acids during the oxidation process.

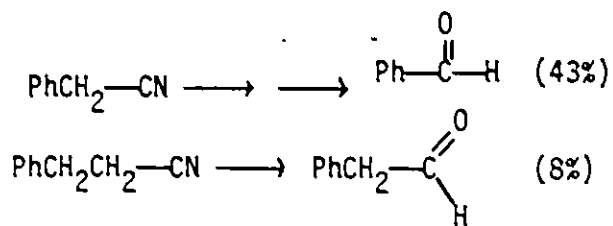

Scheme 1

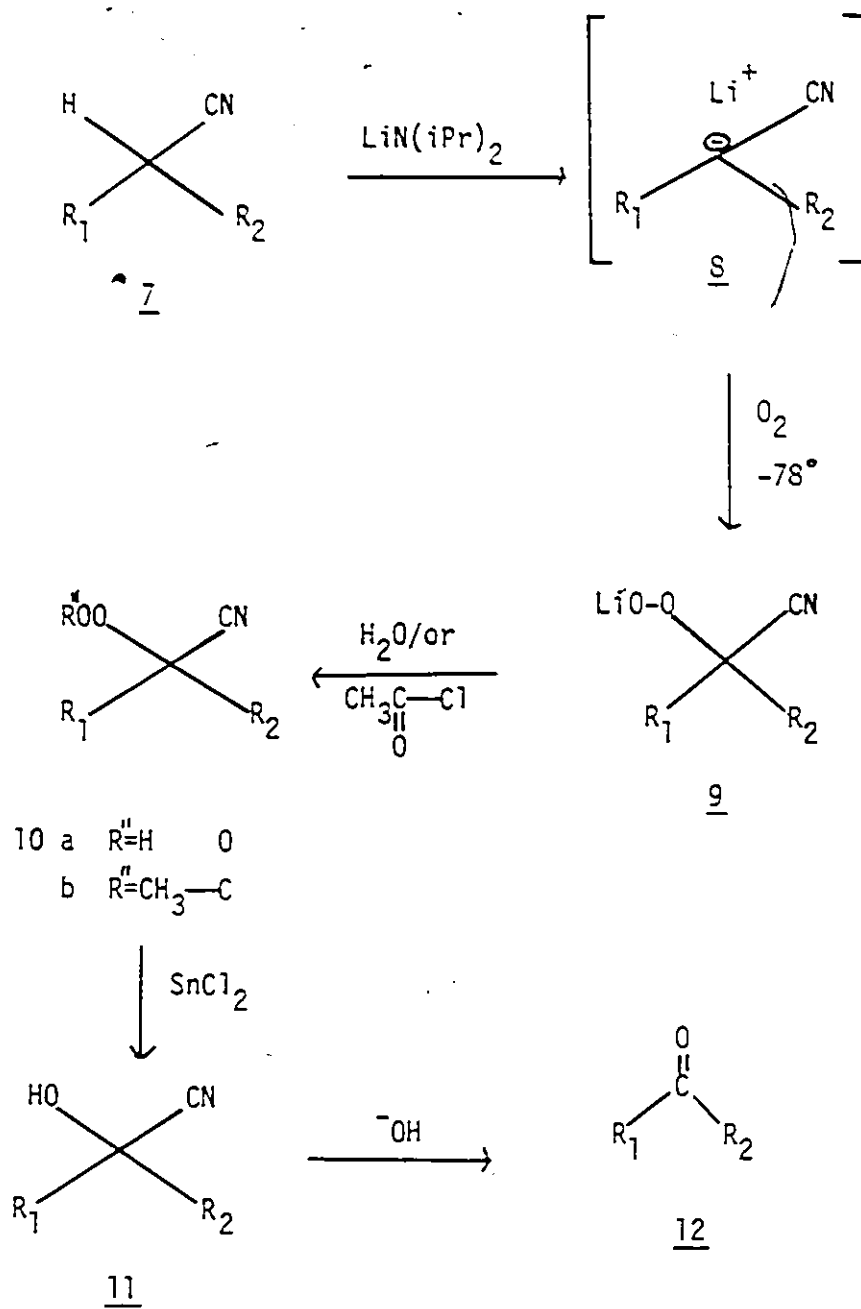

Amides

The carbanions generated in the reactions of N,N-dialkyl amides with LDA were found (6) to undergo rapid oxidation, under mild conditions, when treated with molecular oxygen. This procedure was found to be quite efficient and general for  $\alpha$ -hydroxylation of amides.

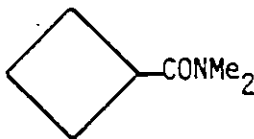
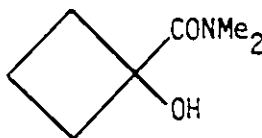
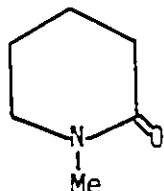
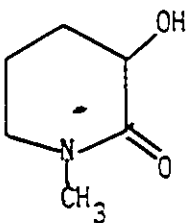
<u>Amide</u>	<u><math>\alpha</math>-hydroxy derivative</u>	<u>Yield (%)</u>
$\text{CH}_3\text{CH}_2\text{CONMe}_2$	$\text{CH}_3\text{CH}(\text{OH})\text{CONMe}_2$	72
$\text{CH}_3\text{CH}_2\text{CH}_2\text{CONMe}_2$	$\text{CH}_3\text{CH}_2\text{CH}(\text{OH})\text{CONMe}_2$	85
		81
		80

Miscellaneous

Rauchschwalbe and Schlosser (7) have shown that allylic carbanions, prepared by treatment of olefins with  $t\text{-BuO}^-\text{K}^+$ / $\text{sec-BuLi}$  can be regioselectively oxidized by treatment with dimethoxyfluoroborane followed by decomposition of the intermediate borane with hydrogen peroxide.

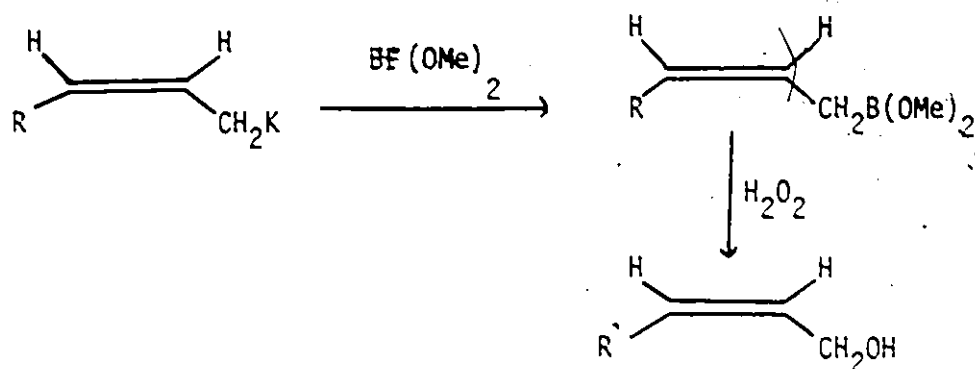

Thus, metallation of isoprene followed by reaction with  $\text{BF(OMe)}_2$  and  $\text{H}_2\text{O}_2$  gave the allylic alcohol 13 (E/Z=92:8) in 65% yield.

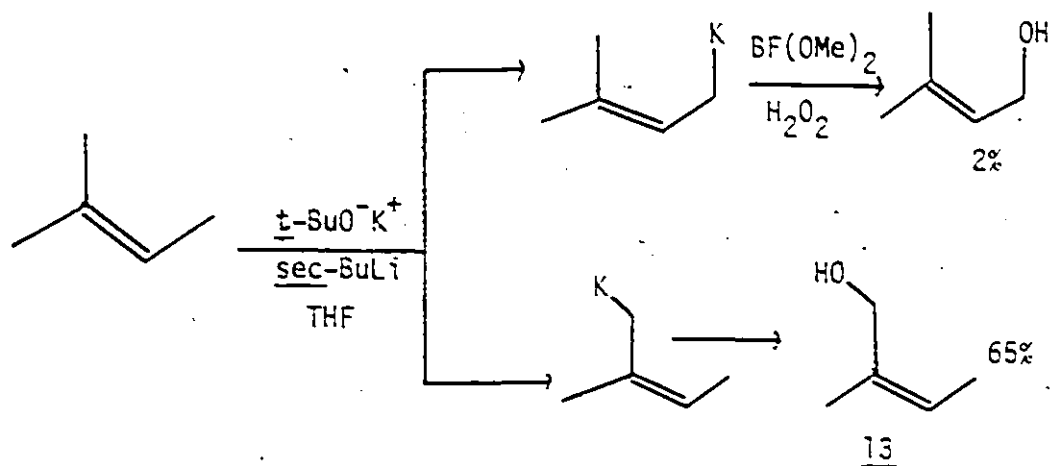

### Mechanistic Considerations

The transformation of an organolithium reagent to the corresponding alcoholate ordinarily occurs in two distinct steps (8).

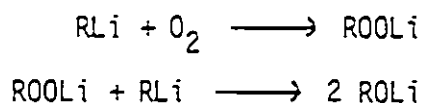

The formation of the organolithium peroxide was confirmed by Walling and Buckler (9). These authors oxidized *n*-butyl lithium in diethyl ether with  $\text{O}_2$  at  $-78^\circ\text{C}$  and obtained, after hydrolysis, the corresponding

hydroperoxides in 35% yield.

The mechanism for the initial formation of the hydroperoxide is not known. Various theories have been put forth (10). These include (i) a free radical chain process;

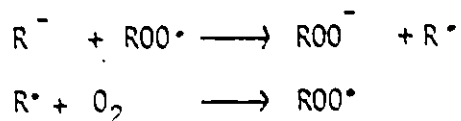

(ii) a one step reaction between the carbanion and oxygen;

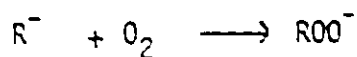

(iii) a one-electron transfer between the carbanion and oxygen followed by collapse of the intermediate 14 to the hydroperoxide carbanion.



14

Process (ii) is considered highly unlikely since a change in spin multiplicity must accompany bond formation.

Some evidence has been recently presented supporting process (iii). Thus, Whitesides et al (11) found that treatment of either the E or Z isomers of 1-lithio-1-phenyl-1-butene with  $O_2$  at  $-78^\circ$  resulted in partial loss of stereochemistry about the double bond. A linear vinyl radical was suggested as a plausible intermediate to rationalize the loss of stereochemistry.

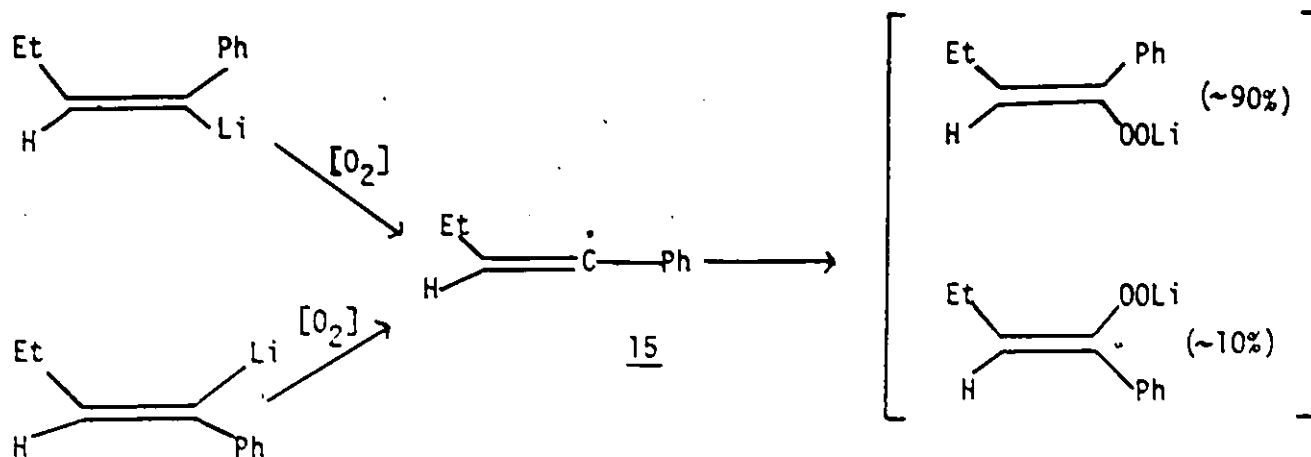

In contrast treatment of the same vinyl lithiums with lithium t-butyl peroxide gave enolates with retention of stereochemistry suggesting that free radicals are not involved in this process.

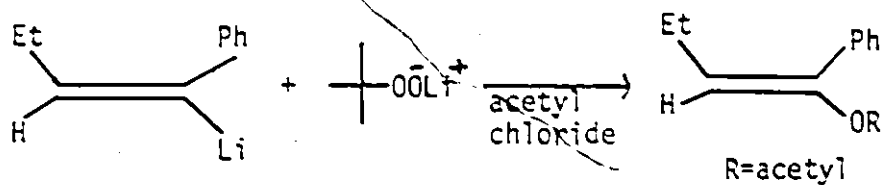

The oxygen transfer between the lithio peroxide and the lithio carbanion is somewhat surprising. The mechanism has not been investigated. It could conceivably be depicted as shown below.

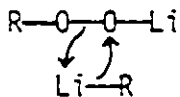

Results and Discussion

To date, there has been no report of the conversion of the sulfone unit into its  $\alpha$ -hydroxy derivative and subsequently to the corresponding aldehyde or ketone.

Formation of aldehydes and ketones from  $\alpha$ -hydroxy sulfones upon treatment with base is a well established process (12).

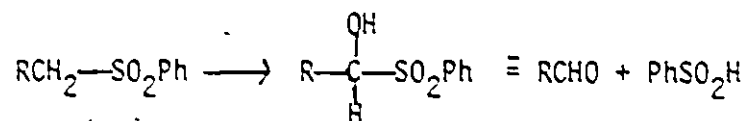

Such a conversion could greatly extend the use of sulfone chemistry in synthesis. A simple alkyl phenyl sulfone, readily prepared from an alkyl halide, could thus be converted after alkylation and oxidation into a ketone. The overall process is shown below.

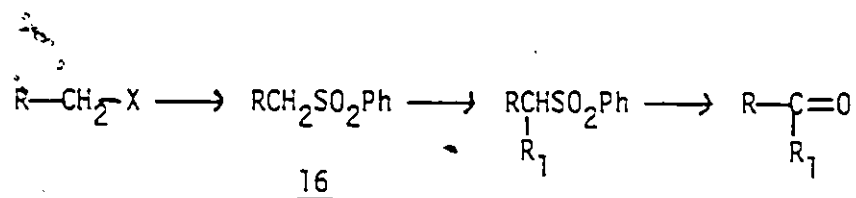

The species 16 can be considered the equivalent of the acyl anion  $\text{RCO}^\ominus$  (13).

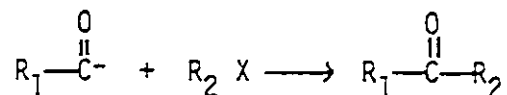

### Ketone Generating Systems

The only system studied in which it was possible to affect  $\alpha$ -sulfonyl carbanion oxidation and hence ketone formation was benzhydryl phenyl sulfone 17.

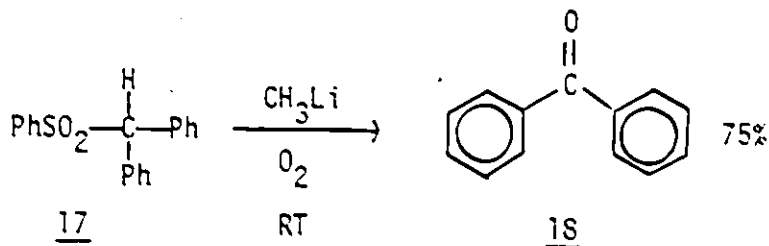

Reaction of the red-coloured carbanion solution of 17 with dry oxygen at room temperature resulted in the dissipation of the colour within five minutes. Workup gave benzophenone 18 in 75% isolated yield.

It was also possible to affect oxidation of the carbanion of 17 with elemental sulfur. Addition of sulfur to a solution of the carbanion at  $-78^\circ$  gave immediately a greenish blue solution. As the reaction mixture was allowed to warm to room temperature a deep blue colour developed. This deep blue colour is attributed to the formation of thiobenzophenone. Workup of the reaction mixture furnished a blue solid 19 which after standing in air for 24 hrs. was converted to benzophenone in an overall yield of 95%. The instability of thioketones in air and their conversion to the corresponding ketones is well known (14).

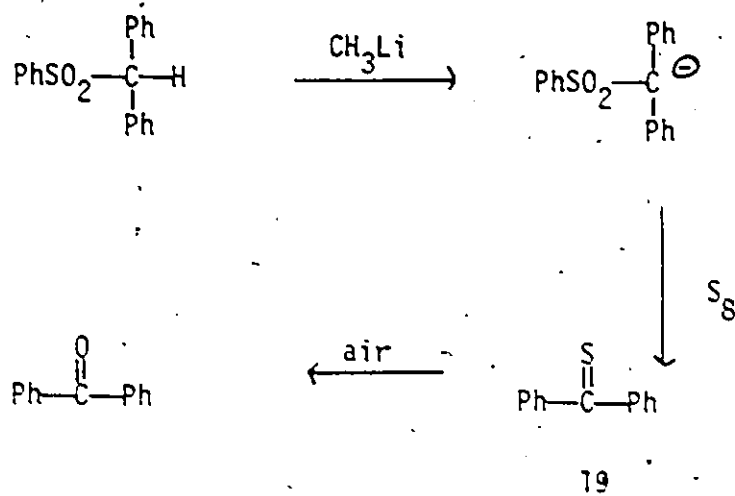

The reaction of diaryl phenylsulfonyl carbanions with  $\text{S}_8$  may constitute a potential method for the preparation of diaryl thioketones 22. The required starting sulfones 21 may be prepared simply by treatment of benzhydrol derivative 20 with phenylsulfinic acid. Other methods of preparing diaryl thioketones have involved, for example, addition of  $\text{P}_2\text{S}_5$  to benzophenone derivatives (15).

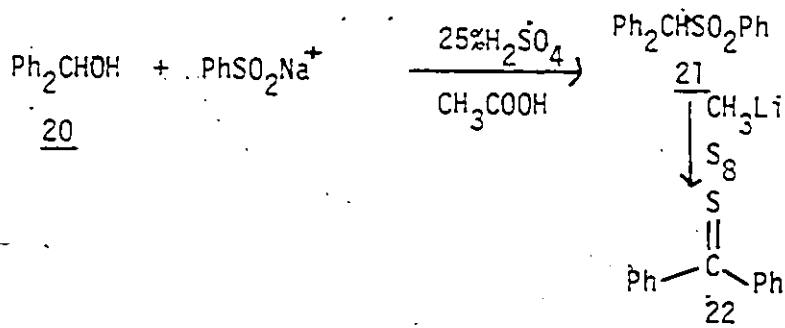

Our attention then turned to the system 23. Attempted oxidation of its carbanion proved fruitless and starting material was recovered when the carbanion was treated with  $\text{O}_2$  at  $-78^\circ$  or at room temperature, while reaction with  $\text{BF}(\text{OMe})_2/\text{H}_2\text{O}_2$  following Schlosser's methodology was also unsuccessful. Some reaction did occur in the latter case but no acetophenone could be detected in the NMR of the

crude product.

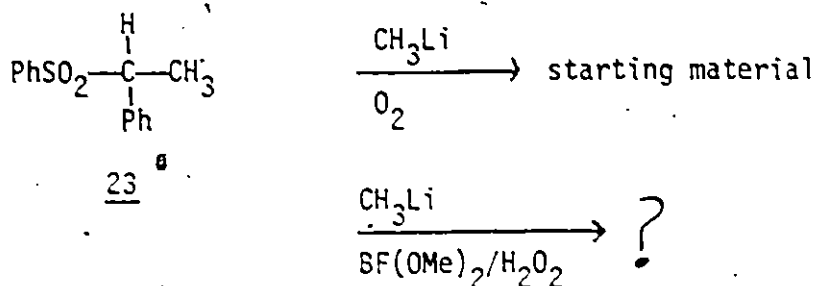

Conversion of cis 4-t-butyl phenyl sulfone 24 to 4-t-butyl cyclohexanone was also not successful. Thus attempted oxidation of the carbanion of 24 with oxygen or BF (OMe)<sub>2</sub>/H<sub>2</sub>O<sub>2</sub> resulted in recovery of epimerized starting material in the former and unidentified materials for the latter experiment.

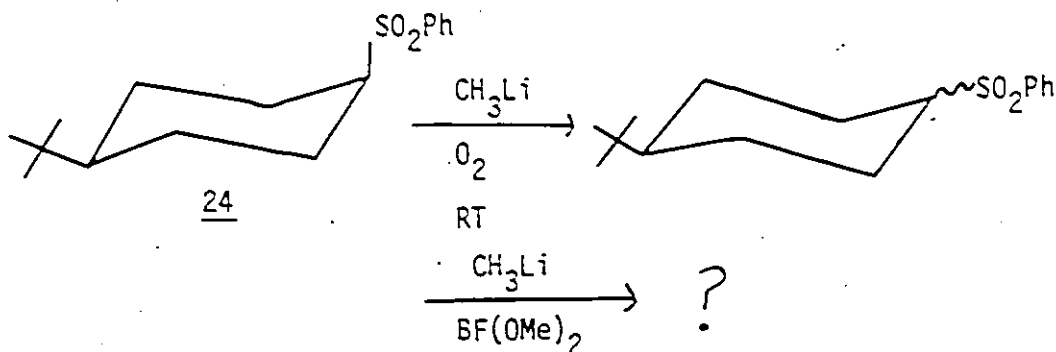

### Aldehyde Generating Systems

These efforts involved attempted generation of benzaldehyde from the reaction of various  $\alpha$ -carbanions of sulfur derivatives with O<sub>2</sub>.

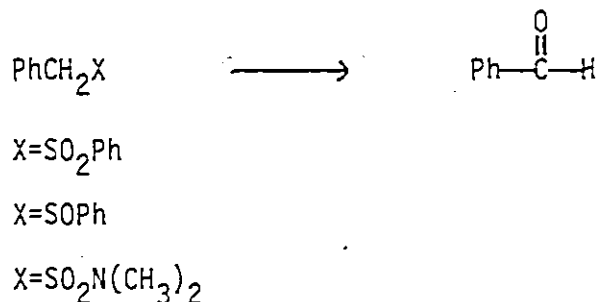

Thus, the carbanion of benzyl phenyl sulfone 25 when treated with molecular oxygen, at  $-78^{\circ}$ , furnished traces of benzaldehyde as evidenced by its distinctive odour and comparative TLC behaviour.

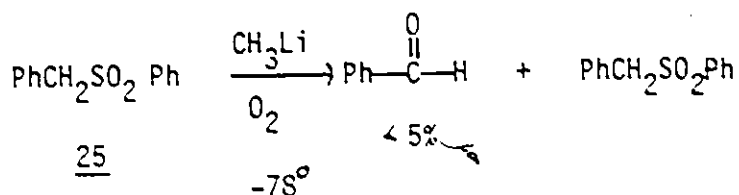

When the reaction was carried out at room temperature, the sole observed product was the hydroxy sulfone 26 which was generated by addition of the initial carbanion of 25 to benzaldehyde.

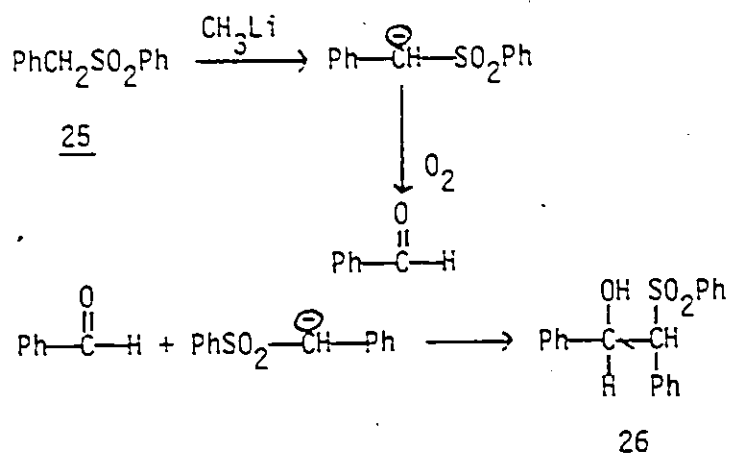

Formation of the adduct 26 suggests that decomposition of the intermediate lithio peroxide to benzaldehyde at  $25^{\circ}$  proceeds faster than formation of this peroxide (assuming that the initial electron transfer step is not reversible) and also that addition of the carbanion to benzaldehyde is faster than aldehyde generation, otherwise benzaldehyde would accumulate.

It was felt that if the electron transfer step could be enhanced, thus possibly resulting in more rapid formation of benzaldehyde, adduct formation might be depressed.

The reaction was repeated in the presence of  $\text{CuCl}_2$ , an electron acceptor, but once again adduct formation was the only observed product.

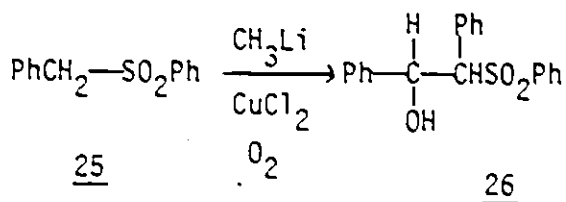

Other unsuccessful methods which were attempted for the oxidation of the carbanion of 25 are summarized below.

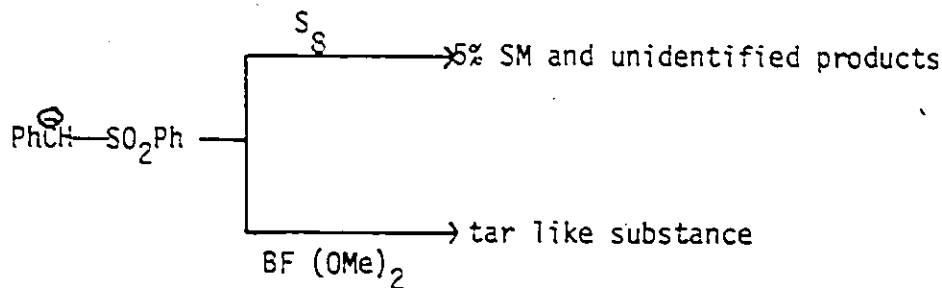

The effect of changing the oxidation state of the sulfur was also briefly investigated.

The sulfonamide 27 when treated with  $\text{CH}_3\text{Li}$ , followed by  $\text{O}_2$ , at either  $-78^\circ$  or  $0^\circ\text{C}$  provided 80% recovery of starting material and 20% of a material which was not isolated but which appeared to be the adduct 28 similar to the product encountered with the oxidation of benzyl phenyl sulfone. No benzaldehyde was detected, either by NMR or TLC.

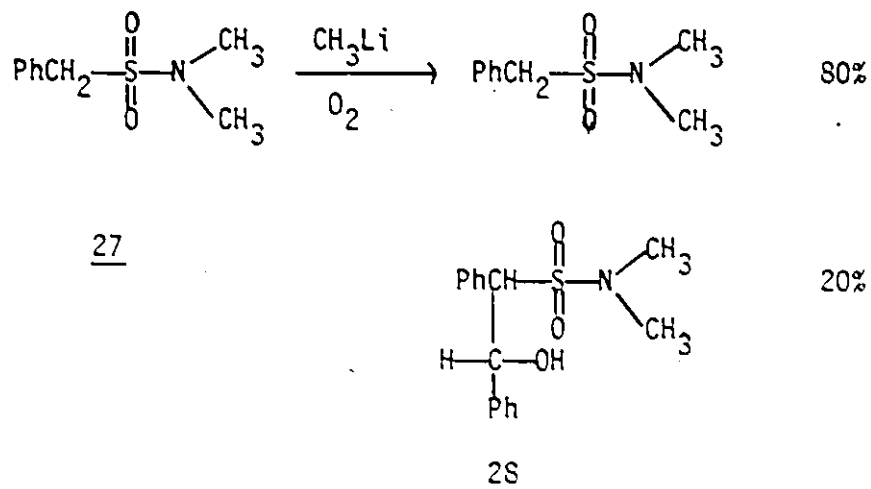

### Sulfoxide

The carbanion of benzyl phenyl sulfoxide 29, generated at room temperature by treatment with  $\text{CH}_3\text{Li}$ , was found to be unreactive towards molecular oxygen. Quenching of the reaction mixture with  $\text{D}_2\text{O}$ , after oxygenation, followed by acidification with ammonium chloride resulted in 90% recovery of the  $\alpha$ -mono-deutero derivative.

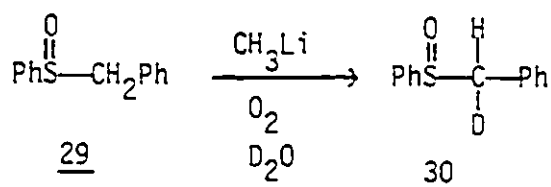

### Conclusions

The attempted oxidations of the ketone generating systems which were described above gave results which are difficult to rationalize. For example, why did oxidation of the carbanion bearing two phenyl groups proceed smoothly while the phenyl methyl analog was completely unreactive under the same reaction conditions?

The reaction of the benzylic sulfur carbanions with  $O_2$  appeared to be sensitive to the oxidation state of the sulfur. Thus the sulfone 25 was oxidized via its carbanion to the extent of 50%, the sulfonamide carbanion 27 gave 10% oxidation, whereas in the lithio carbanion of the sulfoxide 29 no oxidation was observed.

PART III

$\alpha$ -Lithio Sulfones

$\alpha$ -Lithio Sulfones

Structure and Stereochemistry of their Reaction with Electrophiles.

Introduction

The major impetus for the work described in this part of the thesis was due to some unusual results of Legault and Durst (1) in connection with reactions of the lithio derivatives of cis and trans-2,6-diphenylthiane-1,1-dioxide. These authors noted that the carbanion of the cis diphenyl sulfone 1 when quenched with  $H_2O$  at  $-78^\circ$  resulted in the formation of the trans derivative 2 exclusively.

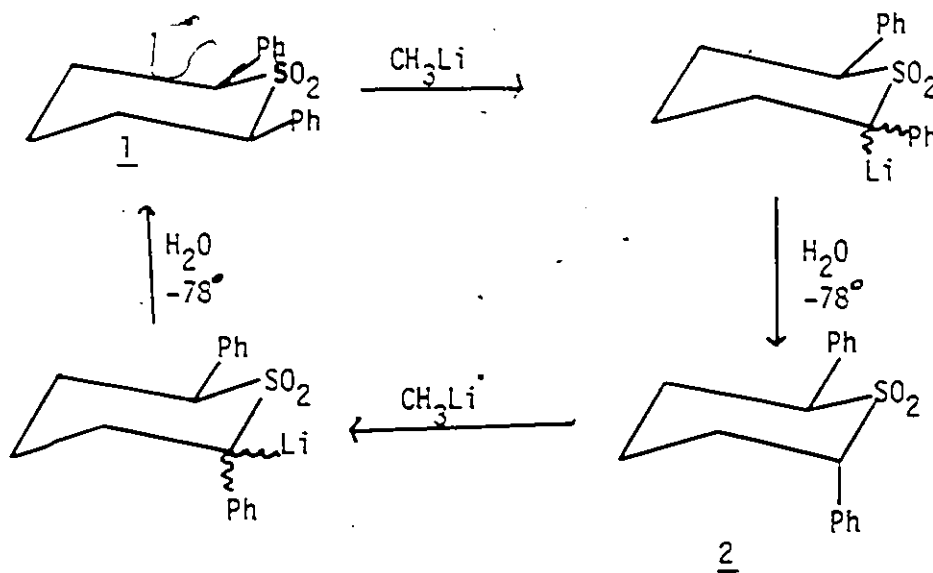

More interestingly, they claimed that treatment of the trans isomer 2 with methyl lithium followed by quenching with  $H_2O$  at  $-78^\circ$  resulted in formation of the cis isomer 1. These results were quite remarkable in that both compounds 1 and 2 were claimed by Legault and Durst to have undergone deprotonation

and subsequent protonation in a stereospecific manner with net inversion at the carbanion centre. These initial findings were considered sufficiently intriguing to merit closer scrutiny.

Thus, it was decided to reexamine Legault's original results with respect to the formation and reaction of the carbanions of the cis and trans diphenyl sulfones 1 and 2 with several electrophiles and to determine if the two carbanions interconverted at higher temperatures.

Another goal of this project was to examine the carbanions generated from the diphenyl sulfones 1 or 2 and the conformationally rigid 4-t-butyl sulfone 3 via  $^1\text{H}$  and/or  $^{13}\text{C}$  NMR spectroscopy.

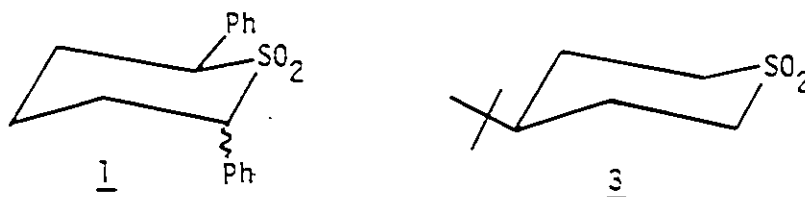

### Synthesis of 1 and 3

The sulfone 1 was prepared according to the following equation.

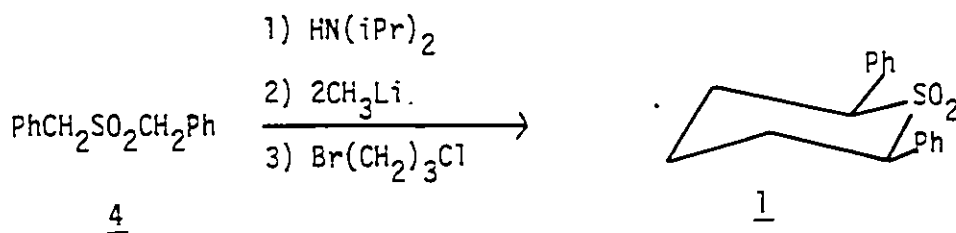

Thus, reaction of the dianion of dibenzyl sulfone 4 with one equivalent of bromochloropropane at  $-78^{\circ}$ , followed by warming to room temperature resulted in an 80% yield of the cis diphenyl sulfone 1. The structure and cis stereochemistry of the product was assigned on the basis of the spectral data. In particular the axial benzylic hydrogens ( $\delta=5.16$  ppm) showed J's of 11.9 and 3.1 Hz consistent with the assigned cis structure. Other signals were observed at 1.5-2.9, (m, 6H) and 7.2-7.6, (m, 10H).

The 4-t-butylthiane-1,1-dioxide 3 was prepared according to a method suggested to us by Dr. A. Marquet, C.N.R.S., Thiais, France. The synthetic plan employed is outlined in Scheme 1. The synthesis of the sulfone 3 is straight forward and details are available in the Experimental Section. The structures of intermediates were established on the basis of their IR and NMR spectra. The resultant sulfone 3 exhibited spectral properties in agreement with the assigned structure.

Scheme 1

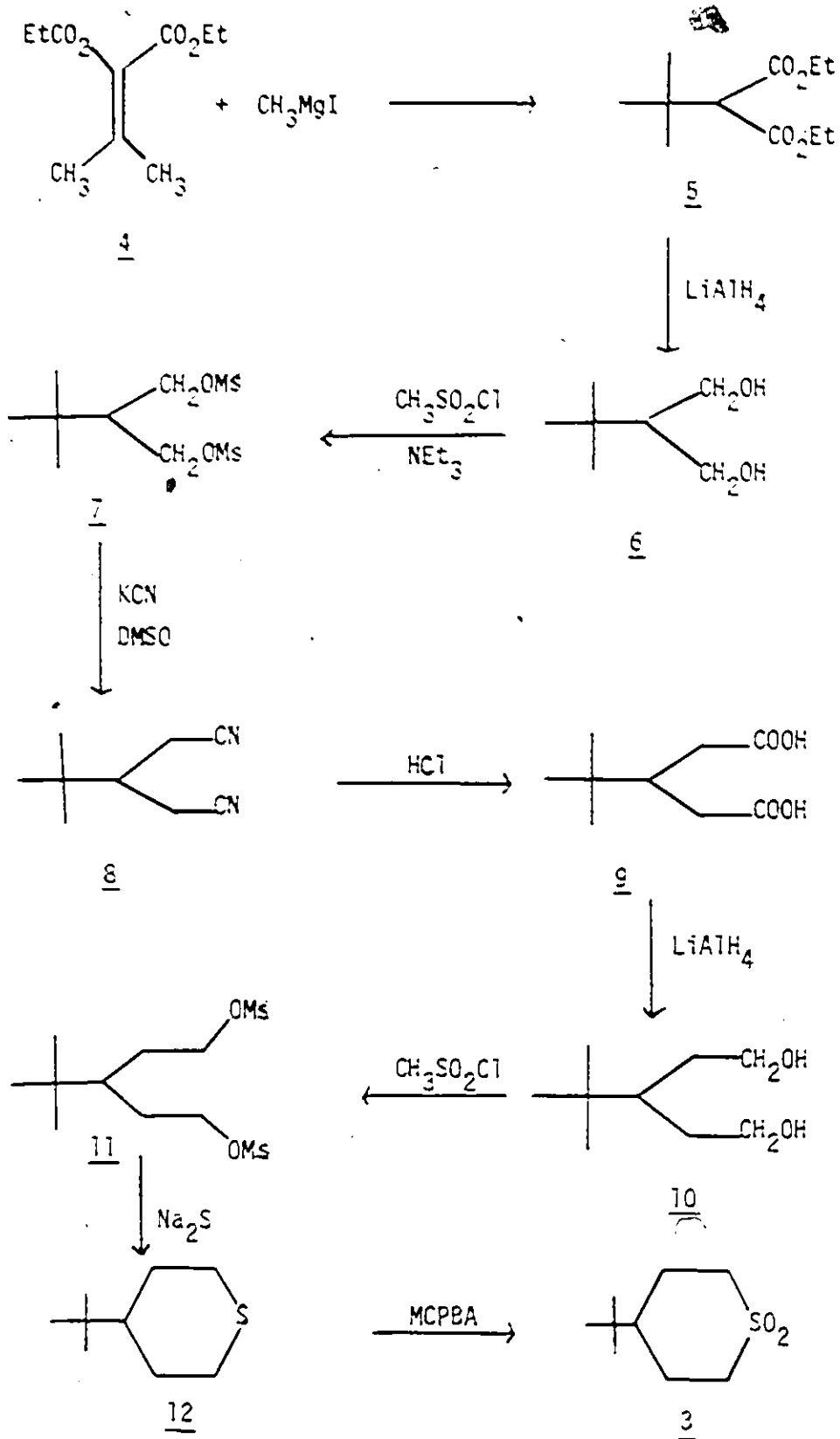

### Results and Discussion

In agreement with the previous observation of Legault the carbanion of 1 when quenched with H<sub>2</sub>O gave the isomeric sulfone 2.

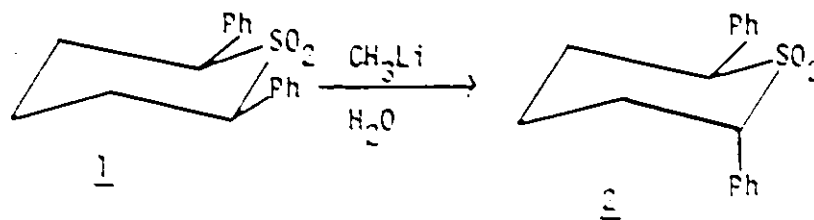

However, contrary to Legault's claim, reaction of 2 with CH<sub>3</sub>Li at temperatures from -78° to +25° followed by H<sub>2</sub>O, (D<sub>2</sub>O) did not give 1, but regenerated only 2. This means that the key result 2 → 1 which suggested the existence of two isomeric carbanions was not repeatable in my hands.

The trans stereochemistry of the sulfone 2 was clearly established on the basis of its spectral data.

Thus, the benzylic hydrogen at δ=5.30 showed J's of 7.2 and 4.2 Hz, a result of averaging aa and ee and 2ae interactions respectively, because of rapid ring inversion of 2. Other absorptions in the <sup>1</sup>H NMR occurred at δ1.8-2.2(m,2H), 2.2-2.9(m,4H) and 7.3-7.8(m,10H).

The <sup>13</sup>C NMR data for both the cis and trans 2,6-diphenylthiane 1,1-dioxide is presented below. (Table I) In particular the shielding of C-4 in the trans isomer (23.4 vs. 27.9) is indicative of an axial phenyl group. This gauche γ effect is well known (2).

Table I

<sup>13</sup>C NMR Data for Cis and Trans 2,6-diphenylthiane-1,1-dioxide

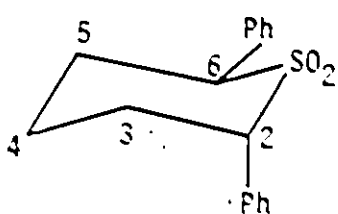

<u>C</u>	<u>δ</u>
2,6	67.2
3,5	32.6
4	23.4

Others 135.9, 132.2, 130.4

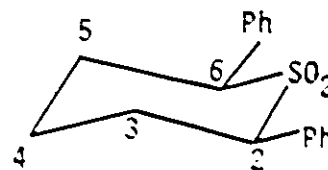

<u>C</u>	<u>δ</u>
2,6	70.3
3,5	34.3
4	27.9

Others 134.6, 132.2, 130.4

It was also shown that the carbanion of 1 or 2 reacted with  $\text{CH}_3\text{I}$  to give a single product assigned structure 13 on the basis of its complete equilibration to 14.

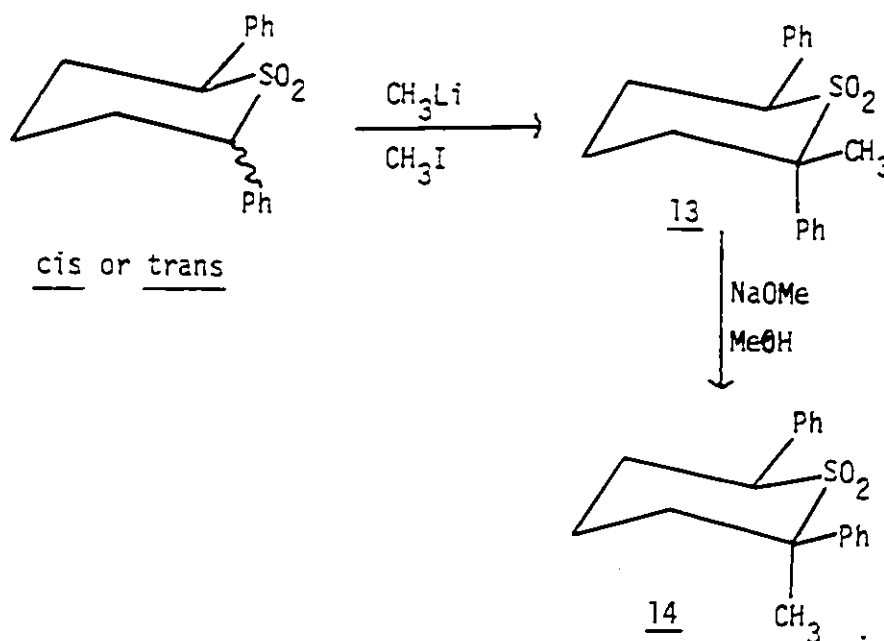

In summary, it has been shown that generation and subsequent trapping of the carbanion of either 1 or 2 results in incorporation of the electrophile in the equatorial position of the ring.

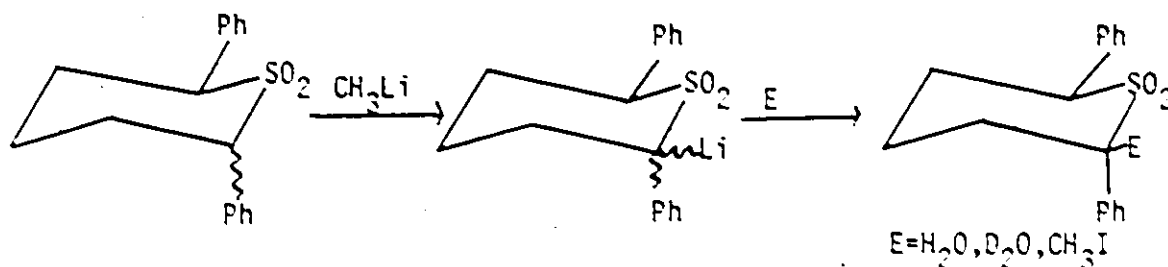

Such stereoselectivity has been observed in other systems in which a lithio carbanion has been stabilized by a sulfur function.

Thus, Durst (3) reported that  $\alpha$ -lithio- $\delta$ -sulfones 16 or 17 when reacted with various electrophiles including  $\text{H}_2\text{O}$ ,  $\text{D}_2\text{O}$ ,  $\text{CH}_3\text{I}$  and acetone gave the products 18 in which the electrophile had entered exclusively in the equatorial position even when the products were the thermodynamically less favoured ones. (Scheme 2)

Eliel and co-workers (4) obtained similar stereochemical results in the reactions of 2-lithio-1,3-dithianes with electrophiles.

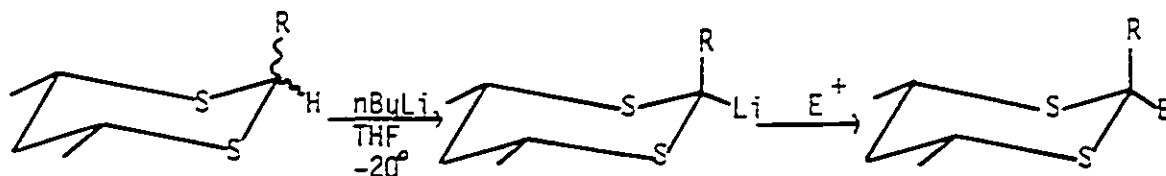

Scheme 2

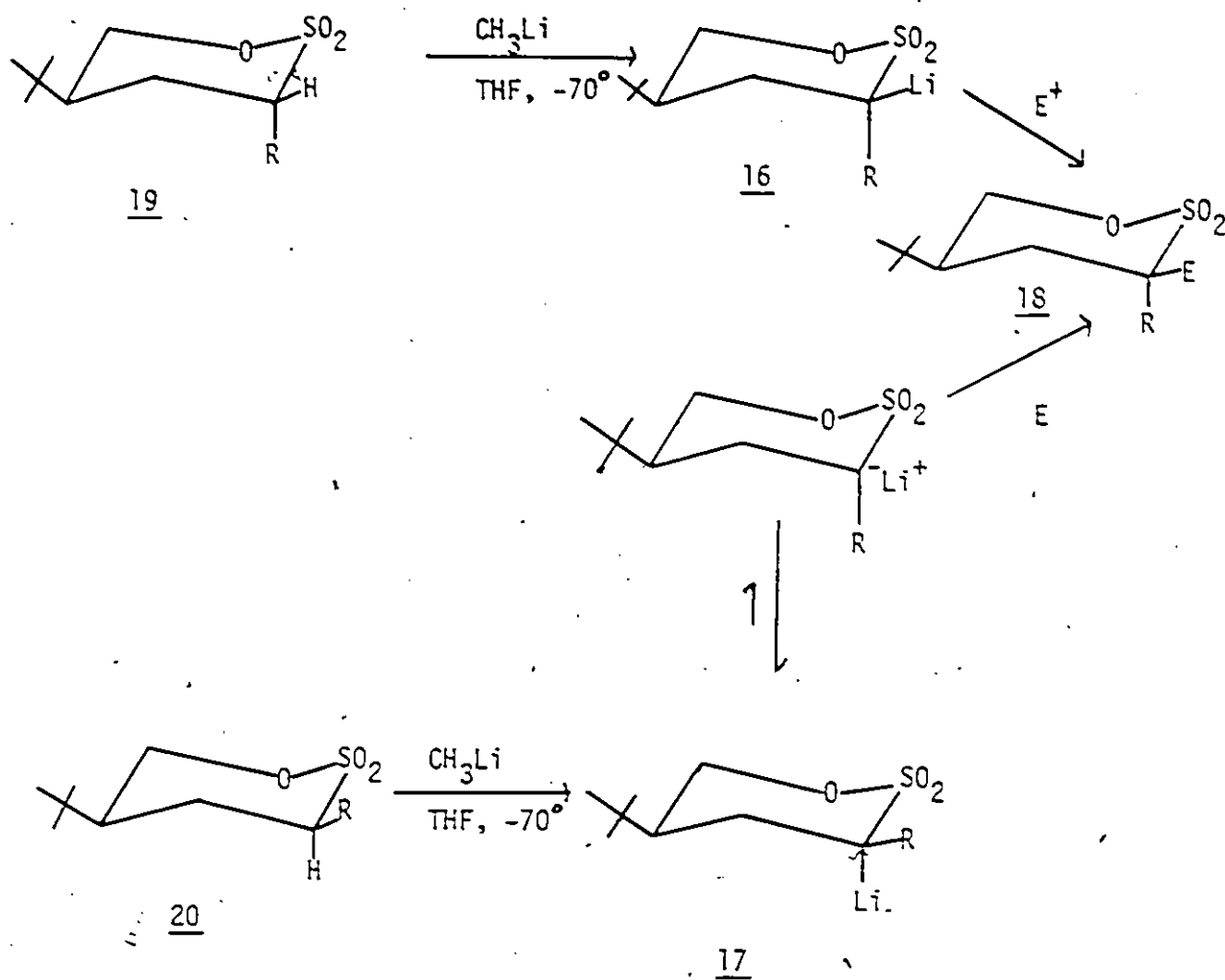

A strong conformational preference for lithio carbanions in acyclic compounds was first noted by Corey (5) and Cram (6) who observed overall retention in the base catalyzed H-D exchange in optically active sulfones of the type  $\text{R}_1\text{R}_2\overset{*}{\text{C}}\text{HSO}_2\text{Ph}$ .

The strong conformational bias for  $\alpha$ -sulfonyl carbanions is also supported by the theoretical studies by Wolfe and co-workers (7).

On the basis of M.O. calculations on the somewhat simplified system  $^{\ominus}\text{CH}_2\text{-SO}_2\text{H}$  it was concluded that the pyramidal carbanion with the lone pair bisecting the O-S-O angle has the lowest energy. It must be kept in mind that these calculations are strictly only applicable to the gas phase.

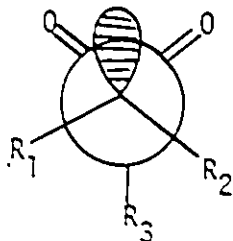

The extension of these results to carbanions in solution may not be justified. (aggregates, solvation effects, etc.)

The metallation and quenching results in the six membered ring series may be interpreted in terms of the intermediacy of  $\text{sp}^3$  hybridized species in which the lithium shows a very strong preference for the equatorial position or an  $\text{sp}^2$  species which reacts with electrophiles in a stereospecific manner with the electrophile approaching syn to the sulfone oxygens.

### Conclusion

Thus, it has been shown that Legault's original claim cannot be substantiated, and that  $\alpha$ -lithio sulfones in a six-membered ring have a strong conformational bias, as in the other systems discussed above, for incorporation of the electrophile in the equatorial position.

## $^1\text{H}$ and $^{13}\text{C}$ NMR of $\alpha$ -Sulfonyl Carbanions

As a probe to the structure of carbanions in solution we attempted to obtain  $^1\text{H}$  or  $^{13}\text{C}$  NMR data on the system 1 and 3.

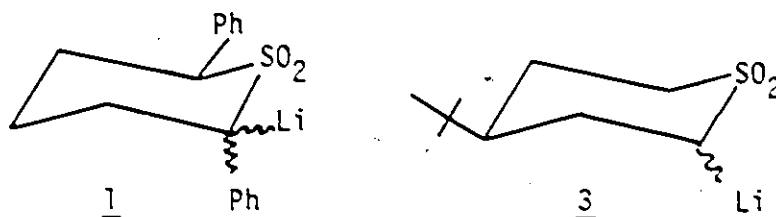

### Diphenyl Sulfone 1

The proton NMR of the carbanion from 1 was obtained at  $-78^\circ$ . The remaining H on C-6 displayed a large and a small coupling constant suggesting that the ring still exists in a chair form.

Attempts to obtain  $^{13}\text{C}$  NMR data for the carbanion of 1 were not successful due to decomposition of the sample in the probe at room temperature.

### - 4-t-butylthiane-1,1-dioxide

The carbanion of the sulfone 3 was generated in THF  $d_8$  by reaction with methyllithium/ether and the  $^{13}\text{C}$  NMR was recorded at room temperature. The  $^{13}\text{C}$  NMR data of the sulfone 3 and its  $\alpha$ -lithio carbanion under identical conditions of solvent and temperature are presented below.

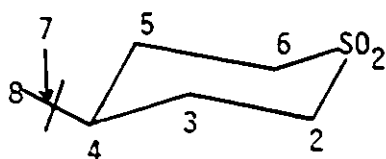

<u>C</u>	<u>δ</u>
2,6	52.0
3,5	26.3
4	46.4
7	32.6
8	27.8

$$J^{13}_{C_2-H} = 134.6 \text{ Hz}$$

Chemical Shifts

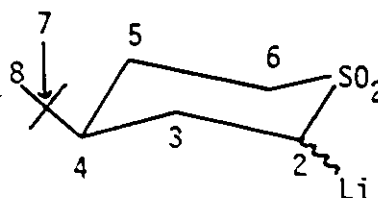

<u>C</u>	<u>δ</u>
2	44.2
3	29.7 or 27.7
4	49.8
5	29.7 or 27.7
6	54.0
7	33.1
8	28.3

$$J^{13}_{C_2-H} = 140 \pm 8 \text{ Hz}$$

It is noteworthy that five different ring carbon absorptions are observed. This suggests that intra or intermolecular transfer of the lithium atom from the  $\alpha$  to the  $\alpha'$  carbon in the carbanion is relatively slow on the NMR time scale.

The 7.7 ppm upfield shift of the lithiated carbon atom is in good agreement with the results observed by Chassaing and Marquet (8) who observed an upfield shift of 9 ppm in going from phenyl methyl sulfone to its  $\alpha$ -lithio carbanion. These effects in the carbanion may be attributed to a charge increase producing the observed shielding effect.

$^{13}C$ -H Coupling Constant

Due to poor resolution in the fully coupled spectrum of the  $\alpha$ -lithio carbanion it was not possible to determine the  $^{13}C$ -H coupling constant for the  $\alpha$  C-H bond in the lithiated species to an accuracy of

greater than  $140 \pm 8$  Hz. ( $^1J_{13C-H}$ ) for the neutral compound is 134.6 Hz.

Such a large error in the coupling constant does not permit any useful conclusion to be drawn.

Marquet et al (8) observed no change in  $^1J_{13C-H}$  in going from phenyl methyl sulfone to its  $\alpha$ -lithio derivative.

In the case of phenyl methyl sulfide a decrease in  $^1J_{13C-H}$  of 20 Hz was interpreted in terms of an  $sp^3$  configuration for the carbanion. This conclusion was drawn from a comparison of this system with the observed decrease in coupling constant (-27 Hz) observed in methyl lithium relative to methane.

The carbanion of phenyl methyl sulfoxide was found to experience a 16.5 Hz increase in coupling constant relative to the neutral compound. This was interpreted as being indicative of a carbanion with substantial  $sp^2$  character since a similar increase (+15 Hz) was observed for diphenyl lithium vs. diphenyl methane.

The sulfone case is thus intermediate between the sulfide and sulfoxide and the hybridization state was considered to be between  $sp^2$  and  $sp^3$ . Marquet's study also showed that the coupling constant is dependent on the solvent and cation.

We became aware of Marquet's results with both cyclic sulfoxides and simple sulfides, sulfoxides, sulfones and sulfoximines during the course of our work and recognized that their study was being carried out at a more sophisticated level (use of crystalline  $CH_3Li$ , solvent effects, etc.) than our own. Thus, this project was not pursued.

EXPERIMENTAL

Melting points (m.p.) were determined with a Thomas Hoover apparatus and are uncorrected; boiling points (b.p.) are also not corrected. Infrared (IR) spectra were obtained as films on sodium chloride plates and in chloroform ( $\text{CHCl}_3$ ) solution for solids on the Beckman IR-20A and Unicam SP1100 Spectrophotometers. Absorptions are reported in  $\text{cm}^{-1}$  and are noted as strong (s), medium (m), weak (w) or broad. Proton nuclear magnetic resonance (NMR) spectra were obtained on Varian Associates Model HA-100 and Model T-60A with deuteriochloroform as solvent (unless otherwise indicated), and tetramethylsilane (TMS) as internal standard. Peak positions are reported in  $\delta$  units as parts per million (ppm) from TMS. The following designations are used in characterising NMR signals: singlet (s), doublet (d), triplet (t), doublet of doublets (dd), multiplet (m) and broad(ened).  $^{13}\text{C}$  nuclear magnetic resonance ( $^{13}\text{C}$  NMR) spectra were obtained on a Varian Associates FT-20 NMR Spectrometer. Peak positions are reported in  $\delta$  units as parts per million (ppm) from TMS. The following designations are used in describing the signals from the off-resonance partially coupled spectra: doublet (d), triplet (t), quartet (q), quaternary. Combustion analyses were carried out by Gailbraith Laboratories, Knoxville, Tennessee. Mass spectra were recorded by Dr. John Krause of this department. Thin-layer (TLC) chromatography was carried out on Merck 60 F-254 precoated plates of 0.25mm thickness. The adsorbant used for column

chromatography was 60-200 mesh Baker Silica Gel. When used as a reaction solvent, tetrahydrofuran (THF) was always distilled from lithium aluminum hydride ( $\text{LiAlH}_4$ ) under a nitrogen atmosphere immediately prior to use. Ethyl acetate and hexane were distilled before using. All carbanion and Grignard reactions were carried out under nitrogen. The Grignard reagent, methylmagnesium iodide ( $\text{CH}_3\text{MgI}$ ) was prepared in ether on a .5mole scale and the concentration was determined by titration (average of 3 determinations). The term usual workup refers to quenching the reaction mixture with excess  $\text{H}_2\text{O}$  or ammonium chloride, extraction with methylene chloride or ether, drying the organics over  $\text{MgSO}_4$  and evaporation of the solvent under reduced pressure.

Unless otherwise stated, all compounds which are described were obtained as clear viscous oils after purification by column chromatography. These compounds were generally not distilled. Attempted distillation in several instances was accompanied by considerable decomposition. Their structure follows from their method of synthesis, spectral properties and further conversion into compounds which were fully characterized.

All solids, unless otherwise described, were obtained as white granular solids.

PART I

Preparation of Epoxy Sulfones

4-Phenylthiobut-1-ene 52

To a potassium phenyl mercaptide solution (18.3g;140 mmole phenyl mercaptan, 9.6g;170 mmole potassium hydroxide) in 200 ml of methanol was added 20.0 g (148 mmole) of 4-bromo-1-butene dropwise at room temperature. The reaction mixture was stirred overnight and then diluted with 250 ml of H<sub>2</sub>O and extracted with 2X100 ml of methylene chloride. The organic extracts were then washed with 3X100 ml of 5% NaOH solution. Drying and evaporation of the organic extracts provided 25g (90%) of the sulfide 52.

NMR:  $\delta$  2.1-2.6 (m,2H), 2.8-3.2 (m,2H), 4.9-6.3 (m,3H), 7.1-7.5 (m,5H)

4-Phenylsulfonylbut-1-ene 53

To 52 (20.5g;125 mmole) dissolved in 100 ml of methylene chloride at room temperature was added 50.5g (250 mmole) of MCPBA in small portions through the condensor. The reaction mixture was stirred overnight and then washed with 4X100 ml of 5% NaOH solution. Drying and evaporation of the organics provided 20.7 (85%) of sulfone 53 after chromatography (1:3 ethyl acetate/hexane).

NMR:  $\delta$  2.1-2.6 (m,2H), 2.9-3.3 (m,2H), 4.7-6.0 (m,3H), 7.3-7.9 (m,5H)  
IR: C=C, 1640 (m); SO<sub>2</sub>, 1155 (s) and 1325 (s)

4-Phenylsulfonyl-1,2-epoxybutane 54

4-Phenylsulfonylbut-1-ene (5.0g; 25.0 mmole) was dissolved in 100 ml of methylene chloride at room temperature and 5.0g (25.0 mmole) of MCPBA was added all at once. The reaction mixture was refluxed for 3 hr and then let cool to room temperature. The reaction mixture was then washed with 2X100 ml of 5% NaOH and the organic layer was dried and evaporated. Chromatography (150g of silica gel with 1:4 ethyl acetate/hexane as eluent) furnished 4.8g (95%) of the epoxy sulfone 54.

NMR:  $\delta$  1.7-3.5 (m, 7H), 7.4-7.8 (m, 5H)

Mesylate 55

4-Pentene-1-ol (9.9g; 115 mmole) was dissolved in 150 ml methylene chloride containing 14.0g (138 mmole) of triethylamine. To this mixture, cooled to 0° was added dropwise 11.4g (138 mmole) of methanesulfonyl chloride dissolved in 50 ml of methylene chloride. The reaction mixture was washed successively with water and 5% HCl solution and the organic extract was dried and evaporated. The crude yield of mesylate 55 was 18.0g (96%).

NMR:  $\delta$  1.5-2.3 (m, 4H), 2.92 (s, 3H), 4.15 (t; J=6Hz, 2H), 4.7-6.0 (m, 3H)

5-Phenylthiopent-1-ene 56

The crude mesylate from above was added to a methanol solution containing 6.8g (121 mmole) potassium hydroxide and 12.7g (115 mmole) phenyl mercaptan. The reaction mixture was stirred overnight and then diluted with 50 ml H<sub>2</sub>O and extracted with 5X100 ml of methylene chloride. The combined organic extracts were washed with 4X100 ml of 5% NaOH solution, dried and evaporated yielding 17.8g (97%) of 56.

NMR:  $\delta$  1.4-2.4 (m, 4H), 2.79 (t, J=7Hz, 2H), 4.7-6.0 (m, 3H), 7.0-7.4 (m, 5H)

5-Phenylsulfonylpent-1-ene 57

In 100 ml of methylene chloride was dissolved 6.36g (3.57 mmole) of the sulfide 56. To this solution cooled in a water bath was added 13.32g (66 mmole) of MCPBA in small portions. After addition was complete the reaction mixture was stirred for 4 hr at room temperature and then washed with 2X100 ml of 5% NaOH solution. Drying, evaporation and chromatography (1:3 ethyl acetate/hexane) furnished 5.0g (66%) of the sulfone 57.

NMR:  $\delta$  1.4-2.4 (m, 4H), 2.9-3.2 (m, 2H), 4.7-5.9 (m, 3H), 7.2-7.9 (m, 5H)

IR: C=C, 1650 (m); SO<sub>2</sub>, 1150 (s) and 1320 (s)

5-Phenylsulfonyl-1,2-epoxypentane 58

Oxidation of 16.3g (92 mmole) of the sulfide 56 with 70.0g (330 mmole) of MCPBA in refluxing methylene chloride, overnight, followed by washing with 4X100 ml NaOH solution and further usual workup gave the epoxy sulfone 58 (18.0g;90%) after chromatography on 250g of silica gel using 1:3 ethyl acetate/hexane as eluent.

NMR:  $\delta$  1.2-2.2 (m,4H), 2.4-3.4 (m,5H), 7.3-8.1 (m,5H)

IR:  $\text{SO}_2$ , 1310 (s) and 1145 (s)

The above compound 58 was also obtained (90%) by epoxidation of 57 with one equivalent of MCPBA.

Benzyl Sulfone 59

In 40 ml of freshly distilled THF was dissolved 800 mg (3.80 mmole) of 5-phenylsulfonylpent-1-ene 57. After cooling to  $-78^\circ$  the carbanion was generated by addition of 3.9 mmole of *n*-butyllithium. To the resultant yellow solution was added 684 mg (4.0 mmole) of benzyl bromide. After warming to room temperature the reaction mixture was poured into 50 ml of saturated ammonium chloride and extracted with 1X50 ml of ether followed by 2X50 ml methylene chloride. The organics are combined, dried and the solvent stripped furnishing an oil which is chromatographed on 50g of silica gel (1:4 ethyl acetate/hexane). Compound 59 was obtained in 64% yield.

NMR:  $\delta$  1.5-2.3 (m,4H), 2.5-3.5 (m,3H), 4.6-5.7 (m,3H), 7.0-8.0 (m,10H)

IR: C=C, 1640 (m); SO<sub>2</sub>, 1140 (s) and 1300 (s)

#### Epoxy Sulfone 60

A solution of 600 mg (2.0 mmole) of 59 and 500 mg (2.5 mmole) of MCPBA was let stir overnight at room temperature. The solution was then washed with 2X50 ml of 5% NaOH solution, dried and the solvent removed. Chromatography of the resultant oil on 50g of silica gel (1:2 ethyl acetate/hexane as eluent) provided 590 mg (95%) of the epoxy sulfone 60.

NMR:  $\delta$  1.3-3.5 (m,10H), 6.9-7.9 (m,10H)

IR: no C=C; SO<sub>2</sub>, 1150 (s) and 1320 (s)

#### Chloro ester 61

In a 500 ml round bottomed flask was placed 75 ml (excess) of commercial THF and .50g of zinc chloride. The flask was equipped with a reflux condenser and cooled in an ice bath. To this was added 110g (1.41 mole) of acetyl chloride, dropwise over 2 hr. The reaction mixture was then stirred at room temperature overnight and workup was affected by addition of 200 ml of H<sub>2</sub>O and extraction with 2X50 ml of saturated sodium carbonate. The organic layer was collected, dried and concentrated on the rotary evaporator. The crude residue was then distilled at atmospheric pressure and the desired compound, the

chloro ester 61 was collected at 180-185° in 86% (130g) yield.

NMR:  $\delta$  1.4-2.1 (m,4H), 2.00 (s,3H), 3.4-3.7 (m,2H), 3.9-4.3 (m,2H)

IR: C=O, 1755 (s)

Hydroxy sulfide 62

In 200 ml of methanol was dissolved 16.8g(300mmole) potassium hydroxide and 32.3 g (291 mmole) thiophenol. To the thiolate, at room temperature, was added 42.3 g (280 mmole) of the chloro ester 61 in 100 ml of methanol. The reaction mixture was stirred overnight and the ester was then saponified by addition of 26g (excess) potassium hydroxide in 100 ml of methanol. After stirring for an additional 24 hr the reaction mixture was poured into 200 ml of H<sub>2</sub>O and extracted with 2X100 ml methylene chloride. Drying and evaporation of the organic extracts furnished the hydroxy sulfide in 84% yield.

NMR:  $\delta$  1.5-1.9 (m,4H), 2.6-3.1 (m,2H), 3.2-3.7 (m,3H, 2H after D<sub>2</sub>O exchange), 6.8-7.2 (m,5H)

IR: OH, 3440 (broad)

Hydroxy sulfone 63

MCPBA (44g;220 mmole) was added in small portions to a solution of 20.0g (110 mmole) of the sulfide 62 in 300 ml of methylene

chloride. After addition was complete the reaction mixture was refluxed for 3 hr. After this period the solution was let cool to room temperature and washed with 4X100 ml of 5% NaOH solution. The organics were dried and the solvent was stripped on the rotary evaporator furnishing 21.0g (89%) of 63 which was purified, as needed, by column chromatography (1:1 ethyl acetate/hexane).

NMR:  $\delta$  1.4-2.0 (m,4H), 2.6-2.9 (OH), 3.16 (t,J=7Hz,2H), 3.58 (t,J=6Hz, 2H), 7.4-7.9 (m,5H)

IR: OH, 3415 (broad); SO<sub>2</sub>, 1150 (s) and 1300 (s)

The hydroxy sulfone 63 was also prepared by hydroboration of 4-phenylsulfonylbut-1-ene 53.

A 250 ml three necked flask was equipped with a condenser, dropping funnel and a magnetic stirrer. The flask was charged with 1.14g (30 mmole) of sodium borohydride in 50 ml of freshly distilled THF and 8.27g (42.2 mmole) of 53. A solution of 40 mmole of BF<sub>3</sub>(Et<sub>2</sub>O)<sub>2</sub> dissolved in 10 ml of THF was added over a 1.5 hr period. The temperature was maintained at 20-25° by using a water bath. The flask was stirred for an additional 20 minutes and excess hydride was decomposed with 5 ml of H<sub>2</sub>O. The trialkyl borane was then oxidized by dropwise addition of 15 ml of 3N NaOH followed by 15 ml of 30% hydrogen peroxide. The reaction mixture was then diluted with 50 ml of H<sub>2</sub>O and extracted with 50 ml of ether and 50 ml of methylene chloride. The organics were dried, concentrated and chromatographed on 200 g of

silica gel (1:1 ethyl acetate/hexane) providing 6.3g (70%) of the hydroxy sulfone 63.

Aldehyde 64

In 25 ml of methylene chloride (dried over phosphorous pentoxide) was suspended 12g (5.6 mmole) of pyridinium chlorochromate and 24g (22.6 mmole) of sodium carbonate. To this suspension at room temperature was added 5.0g (27.5 mmole) of the hydroxy sulfide 62 in 5 ml of ~~methylene chloride~~, dropwise over 15 minutes. After stirring an additional 10 minutes the resultant granular residue was filtered and washed with 50 ml of methylene chloride. The methylene chloride solution was concentrated and the black residue was passed through 20g of silica gel (hexane as eluent). The resultant yellow oil was chromatographed on 100g of silica gel (hexane) and the aldehyde 64 was obtained in 70% yield.

NMR:  $\delta$  1.3-1.9 (m,2H), 2.1-2.6 (m,2H), 2.83 (t,J=7Hz,2H), 6.8-7.2 (m,5H),  
10.00 (s,1H)

IR: C=O, 1710 (s)

Aldehyde 65

The hydroxy sulfone 63 (2.0g;9.8 mmole) was added all at once to a suspension of 3.8g (17.5 mmole) pyridinium chlorochromate in 20 ml of methylene chloride. The reaction mixture immediately became black

and was let stir for 20 minutes. The reaction mixture was then diluted with 50 ml of ether and the supernatant liquid was decanted. This procedure was repeated twice and the combined washings were concentrated. The resultant black tar was chromatographed on 50 g of silica gel (1:4 ethyl acetate/hexane) and furnished 900 mg (45%) of the aldehyde 65.

Yields of 70% were obtained by the addition of 4 equivalents of sodium carbonate before addition of the alcohol.

NMR:  $\delta$  1.8-2.2 (m, 2H), 2.70 (t, J=6Hz, 2H), 3.20 (t, J=6Hz, 2H), 7.4-7.9 (m, 5H), 9.74 (s, 1H)

IR: CO, 1715 (s); SO<sub>2</sub>, 1150 (s) and 1310 (s)

Dimethylbenzylsulfonium chloride 66 (35)

In a 500 ml round bottomed flask was placed 100g (800 mmole) of benzyl chloride, 50.4g (810 mmole) dimethyl sulfide and 120 ml of water. The two phase system was then refluxed for 2.5 days after which time a homogeneous solution was formed. The aqueous solution was then washed with 100 ml of ether to remove any organics and then concentrated to give a solution that was 67% by wt. sulfonium salt (determined by NMR).

Ethyltriphenylphosphonium iodide 71

In 100 ml of toluene was dissolved 28g (106 mmole) of triphenylphosphine and 15g (96 mmole) of ethyl iodide. The solution was refluxed overnight, cooled and the white precipitate collected by

suction filtration. The phosphonium salt 71 was obtained in 80% (35g) yield and then, stored over phosphorous pentoxide and used as required.

#### Epoxy sulfone 69

To a 50 ml methylene chloride solution of 1.2g (5.6 mmole) of the aldehyde 65, 2.0g (8.0 mmole) of dimethylbenzylsulfonium chloride and 200 mg of triethylbenzylammonium chloride was added 10g of 50% NaOH solution dropwise. The reaction mixture was stirred for 15 minutes and then 20 ml of H<sub>2</sub>O was added, followed by extraction of this mixture with 2X50 ml methylene chloride. The organic extracts were dried and the solvent stripped. Chromatography of the crude product on 60g of silica gel with 1:2 ethyl acetate/hexane provided 800 mg (50%) of the epoxy sulfone 69.

NMR:  $\delta$  1.5-2.1 (m,4H), 2.8-3.4 (m,3H), 3.56 (d,J=2Hz) and 4.04 (d,J=4Hz) 1H), 7.1-8.0 (m,10H)

IR: SO<sub>2</sub>, 1150 (s) and 1310 (s)

M.S.	Fragment m/e	Rel. Abundance	Assignment
	302	.01%	M <sup>+</sup>
	105	100	Ph-C≡O <sup>+</sup>
	91	74	[C <sub>7</sub> H <sub>7</sub> ] <sup>+</sup>
	77	62	Ph <sup>+</sup>

6-Phenylthiohex-2-ene 67

To 75 ml of freshly distilled THF at room temperature was added 14.0g (33.5 mmole) of the phosphonium salt 71. To the resultant suspension was added 14 ml (36.4 mmole) of n-BuLi. After addition was complete the solution was stirred for an additional 15 minutes and the resultant red solution was cooled in an ice bath. To the cooled solution was added 4.0g (22 mmole) of the aldehyde 64 in 10 ml of anhydrous THF. The reaction mixture immediately turned light orange and was stirred for an additional 5 minutes. The reaction mixture was then quenched with 50 ml of H<sub>2</sub>O, extracted with 1X50 ml of ether and 1X50 ml of methylene chloride. Drying and evaporation of the organics furnished a crude oil which was chromatographed on 50g of silica gel (hexane as eluent) providing 67 in 90% (4.1g) yield.

NMR:  $\delta$  1.0-1.7 (m,7H), 1.7-2.3 (m,2H), 2.80 (t,J=6Hz,2H), 4.7-5.4 (m,2H),  
6.7-7.1 (m,5H)

IR: C=C, 1620 (m)

Epoxy Sulfone 70

The sulfide olefin 67 was oxidized and epoxidized by dropwise addition of 16.0g (80 mmole) of MCPBA in 100 ml of methylene chloride to a solution of 4.0g (20.8 mmole) of 67 in 100 ml of methylene chloride. After addition was complete the reaction mixture was refluxed overnight, cooled to room temperature, and washed with 2X150 ml of 5% NaOH solution.

Drying and evaporation of the organic layer, followed by chromatography on 100g of silica gel (1:2 ethyl acetate/hexane) provided 4.2g (85%) of the epoxy sulfone 70.

NMR:  $\delta$  1.18 (d, J=5Hz) and 1.30 (d, J=5Hz) 3H, 1.0-2.1 (m, 4H), 2.3-3.4 (m, 4H), 7.4-8.0 (m, 5H)

IR: SO<sub>2</sub>, 1150 (s) and 1310 (s)

M.S.	Fragment m/e	Rel. Abundance	Assignment
	99	21	[ M-SO <sub>2</sub> Ph ] <sup>+</sup>
	98	100	[ M-PhSO <sub>2</sub> H ] <sup>+</sup>
	82	62	[ 98-CH <sub>4</sub> ] <sup>+</sup>
	77	42	Ph <sup>+</sup>
	143	38	[ PhSO <sub>2</sub> H <sub>2</sub> ] <sup>++</sup>

Epoxy sulfide 72

The aldehyde 64 (7.5g; 41.6 mmole) was dissolved in 30 ml of methylene chloride and to this solution was added 30 mg of TEBA and 8.5g (45 mmole) of the sulfonium salt 66. The reaction mixture was cooled in an ice bath and 40g of 50% NaOH solution were added dropwise via a dropping funnel. After stirring for 1 hr the reaction mixture was diluted with 50 ml of H<sub>2</sub>O and extracted with 1X50 ml of methylene chloride. Drying and evaporation of the solvent gave a crude oil which

was chromatographed on 150g of silica gel using 500 ml of hexane followed by 5% ethyl acetate/hexane. The epoxy sulfide 72 was obtained in 71% (8.0g) yield.

NMR:  $\delta$  1.4-2.0 (m,4H), 2.5-3.0 (m,3H), 3.40[(d,J=2Hz) and 3.83 (d,J=4Hz) 1H)], 6.6-7.1 (m,10H)

IR: no aldehyde peak observed

The above mentioned material 5.2g (19.3 mmole) was epoxidized with 8.0g (40 mmole) of MCPBA. The epoxy sulfone 69 was obtained in 87% yield after usual workup and chromatography (1:2 ethyl acetate/hexane).

6-Phenylsulfonylhex-2-ene 68:

To a solution of the phosphonium salt 71 (4.3g;10.4 mmole) in THF at  $-78^{\circ}$  was added 7.1 ml of 1.6M  $\text{CH}_3\text{Li}$  (11.3 mmole). After 10 minutes the aldehyde 65 (2.1g;10 mmole) was added and the reaction mixture was let warm to room temperature over 1 hr during which time the initial orange colour of the solution was dissipated. The reaction mixture was then quenched with 10 ml of saturated ammonium chloride, extracted with 2X50 ml of ether, dried and the solvent stripped. The crude oil was chromatographed (1:1 ethyl acetate/hexane) on 50g of silica gel thus furnishing 580 mg (25%) of 68.

NMR:  $\delta$  1.1-2.3 (m,7H), 2.9-3.3 (m,2H), 4.9-5.6 (m,2H), 7.3-7.9 (m,5H)

The above mentioned material (500 mg, 2.5 mmole) was epoxidized with 700 mg (3.5 mmole) of MCPBA. Usual workup furnished 92% of the epoxy sulfone 70.

### Base Induced Cyclizations

#### 3-Phenylsulfonylcyclobutanol 73

To the epoxy sulfone 54 (9.0g; 43 mmole) dissolved in 100 ml of freshly distilled THF under nitrogen was added 44 ml (96 mmole) of  $\text{CH}_3\text{MgI}$ . The reaction mixture was stirred overnight and then poured into 100 ml of saturated ammonium chloride solution, extracted with 1X100 ml ether followed by 2X100 ml methylene chloride. The organic extracts were combined, dried and the solvent stripped. The cyclobutanol 72 was obtained in 80% yield after chromatography on 250g silica gel (1:1 ethyl acetate/hexane).

NMR:  $\delta$  2.3-2.8 (m, 4H), 3.95 (d, 1H, OH), 3.1-3.5 (m, 1H), 4.0-4.6 (m, 1H),  
7.4-8.0 (m, 5H)

IR: OH, 3500 (broad);  $\text{SO}_2$ , 1150 (s) and 1310 (s)

Anal. Calcd. for  $\text{C}_{10}\text{H}_{12}\text{O}_3\text{S}$ : C, 56.60; H, 5.66 Found: C, 56.93; H, 5.48

### 3-Phenylsulfonylcyclopentanol 75

5-phenylsulfonyl-1,2-epoxypentane 58 (4.4g; 19.4 mmole) was dissolved in 50 ml of dry THF at  $-70^{\circ}$  and reacted with 45 mmole of  $\text{CH}_3\text{MgI}$  in ether. The solution was stirred and allowed to warm to room temperature and kept for 18 hr. Workup was accomplished by pouring the reaction mixture into 100 ml of saturated ammonium chloride solution and extracting with 100 ml of ether, followed by 2X100 ml of methylene chloride. The organic extracts were combined, dried, and the solvent evaporated. Column chromatography (1:4 ethyl acetate/hexane) gave 3.3g (75%) of the desired cyclopentanol 75.

NMR:  $\delta$  1.7-2.4 (m, 6H), 2.9-3.1 (1H, OH), 3.5-3.9 (m, 1H), 4.2-4.6 (m, 1H),  
7.4-7.9 (m, 5H)

IR: OH, 3500 (broad);  $\text{SO}_2$ , 1300 (s) and 1150 (s)

Anal. Calcd. for  $\text{C}_{11}\text{H}_{14}\text{O}_3\text{S}$ : C, 58.41; H, 6.19 Found: C, 58.17; H, 6.16

### "One-Pot" Preparation of Cyclobutanols and Cyclopentanols

#### Methyl phenyl sulfone 77

This compound was obtained in 90% yield by oxidation of thioanisole (30.0 ml, 32g; 254 moles) with MCPBA (100 g, 500 mmole).  
m.p.  $86-87^{\circ}$  (methylene chloride/pentane) Lit. m.p.  $88^{\circ}$  (59).

NMR:  $\delta$  3.07 (s,3H), 7.6-8.1 (m,5H)

IR: SO<sub>2</sub>, 1120 (s) and 1300 (s)

Benzyl phenyl sulfone 7S

To the phenyl thiolate (10.7g; 98 mmole phenyl thiol 6.0g; 107 mmole KOH) in 100 ml of methanol was added 12.6g (100 mmole) benzyl chloride. Usual workup afforded 18.0g (90%) of benzyl phenyl sulfide.

NMR:  $\delta$  4.00 (s,2H), 6.8-7.3 (m,10H)

The above sulfide (5.3g; 26.5 mmole) was oxidized with 11.0g (55 mmole) MCPBA. The sulfone 7S was obtained in 95% as white crystals. m.p. 146-147° (methylene chloride/pentane) Lit. m.p. 148° (60).

3-Phenyl-3-phenylsulfonylcyclopentanol 80

Benzyl phenyl sulfone (786 mg; 3.3 mmole) was dissolved in 25 ml of THF containing 1 ml of HMPTA. The solution was cooled to -70° and reacted with 3.6 mmole of CH<sub>3</sub>Li followed by 543 mg (3.6 mmole) of 4-bromo-1,2-epoxybutane. The reaction mixture was warmed to room temperature and kept until the starting material had disappeared (TLC). The reaction mixture was then cooled to -70° and treated with 2.1 equivalents of CH<sub>3</sub>MgI, warmed to room temperature and stirred for 48 hr. Workup was accomplished by pouring the reaction mixture into saturated NH<sub>4</sub>Cl solution, extracting with 1X50 ml ether and then 1X100 ml methylene

chloride, drying the organic extracts and evaporating the solvents. The crude product was purified by column chromatography (1:2 ethyl acetate/hexane). The yield of viscous oil was 750 mg (75%).

NMR:  $\delta$  2.0-3.4 (m, 6H), 3.4-3.8 (1H, OH), 4.2-4.6 (m, 1H), 7.0-7.6 (m, 10H)

IR: OH, 3500 (broad);  $\text{SO}_2$ , 1130 (s) and 1300 (s)

Anal. Calcd. for  $\text{C}_{17}\text{H}_{18}\text{O}_3\text{S}$ : C, 67.55; H, 5.96; Found: C, 67.33; H, 6.10

### 3-Phenylsulfonylcyclopentanol 75

Using the above procedure methyl phenyl sulfone (4.9g; 31.5 mmole) was converted to its carbanion ( $\text{CH}_2\text{Li}$ ; 35 mmole), treated with 4-bromo-1,2-epoxybutane (4.7g; 32 mmole) and then with 65 mmole of  $\text{CH}_3\text{MgI}$ . Workup as described above, followed by chromatography on 150g of silica gel (3:2 ethyl acetate/hexane) furnished 2.5g (35%) of 75.

### 3-Phenyl-3-Phenylsulfonylcyclobutanol 79

To the carbanion of benzyl phenyl sulfone (3.5g; 15 mmole sulfone;  $\text{CH}_2\text{Li}$ , 15.5 mmole) was added 2.4 ml (excess) epibromohydrin followed by 35 mmole of  $\text{CH}_3\text{MgI}$ . Workup and chromatography on 200 g of silica gel (1:2 ethyl acetate/hexane) provided 2.6g (60%) of the above cyclobutanol. m.p. 132° ( $\text{CH}_2\text{Cl}_2/\text{CCl}_4$ )

NMR:  $\delta$  2.9-3.3 (m, 5H, 4H after D<sub>2</sub>O exchange), 4.18 (quintet, J=6.5Hz, 1H),  
and 6.8-7.7 (m, 10H)

IR: OH, 3500 (broad); SO<sub>2</sub>; 1150 (s) and 1305 (s)

Anal. Calcd. for C<sub>16</sub>H<sub>16</sub>O<sub>3</sub>S: C, 66.54; H, 5.92 Found: C, 66.58; H, 5.64

### 3-Phenylsulfonylcyclobutanol 73

This compound was obtained in 46% yield from 711 mg (4.56 mmole) of methyl phenyl sulfone, 4.7 mmole CH<sub>3</sub>Li, excess epibromohydrin and 10 mmole of CH<sub>3</sub>MgI.

### Cyclization of Epoxy Sulfones 69 and 70

#### 2-Phenyl-3-phenylsulfonylcyclopentanol 81

In 50 ml of freshly distilled THF was dissolved 2.0g (6.6 mmole) of epoxy sulfone 69. This was cooled to -78° and 16.5 mmole of CH<sub>3</sub>MgI was added. The resultant white suspension was allowed to warm to room temperature and then stirred under nitrogen for 24 hr. At the end of this period 20 ml of saturated ammonium chloride was added and the solution extracted with 1X50 ml of ether followed by 2X50 ml of methylene chloride. The organic extracts were combined, dried and the solvent stripped. Chromatography of the resultant oil on 100g of silica gel (2:8 ethyl acetate/hexane followed by 1:1 ethyl acetate/hexane) provided 1.35g (67%) of 81 was white crystals. m.p. 105-106° (methylene chloride/hexane).

NMR:  $\delta$  1.7-2.6 (m, 5H, 4H after D<sub>2</sub>O exchange), 3.2-3.4 (m, 1H), 3.5-3.8 (m, 1H), 3.9-4.2 (m, 1H) and 6.8-7.8 (m, 10H)

IR: OH, 3500 (broad); SO<sub>2</sub>, 1145 (s) and 1310 (s)

Anal. Calcd. for C<sub>17</sub>H<sub>18</sub>O<sub>3</sub>S: C, 67.52; H, 6.00, S, 10.60 Found: C, 67.47; H, 6.08; S, 10.99

Reaction of 69 with LDA

Treatment of epoxy sulfone 69 (1.41g; 4.7 mmole) with 5.1 mmole of LDA (prepared from 5.1 mmole of diisopropylamine and 5.2 mmole of *n*-BuLi) in 50 ml of THF provided 1.10g (75%) of the cyclopentanol 81. This material was identical in all respects to 81 obtained by the reaction of 69 with 2 equivalents of CH<sub>3</sub>MgI.

2-Methyl-3-phenylsulfonylcyclopentanol 82

To 1.0g (4.2 mmole) of epoxy sulfone 70 dissolved in 50 ml of anhydrous THF at -78° was added 10 mmole of CH<sub>3</sub>MgI. The resultant white suspension was stirred for 24 hr at ambient temperature and then quenched with 50 ml of saturated ammonium chloride solution. Extraction with 2X100 ml of methylene chloride followed by drying of the organic phase provided the cyclopentanol 82, as a clear oil after chromatography (1:1 ethyl acetate/hexane), in 50% (.5g) yield.

NMR:  $\delta$  1.02 (d, J=6Hz, 3H), 1.6-2.5 (m, 5H), 2.5-2.9 (OH), 3.0-3.3 (m, 1H),

3.6-3.9 (m,1H), 7.4-7.9 (m,5H)

IR: OH, 3450 (broad); SO<sub>2</sub>, 1150 (s) and 1310 (s)

Anal. Calcd. for C<sub>12</sub>H<sub>16</sub>O<sub>3</sub>: C, 60.00; H, 6.66 Found: C, 59.93; H, 6.83

The above cyclopentanol S2 (110mg; .45 mmole) was dissolved in 10 ml of "spectrograde" acetone at 0° and treated with .50 mmole of Jones reagent. The reaction mixture was then stirred for 5 min. and then 5 ml of saturated sodium sulphite was added. Extraction with 20 ml of methylene chloride followed by drying the organic phase provided a solid material which was recrystallized from methylene chloride/hexane, thus furnishing 95 mg (88%) of 2-methyl-3-phenylsulfonyl cyclopentanone S3. m.p. 82.5-83°

NMR: δ 1.13 (d, J=6Hz, 3H), 2.0-2.8 (m, 5H), 3.3-3.5 (m, 1H), 7.5-8.0 (m, 5H)

IR: C=O, 1750 (s); SO<sub>2</sub>; 1150 (s) and 1310 (s)

Anal. Calcd. for C<sub>12</sub>H<sub>14</sub>O<sub>3</sub>S: C, 60.50; H, 5.88; S, 13.44 Found: C, 60.50;  
H, 6.01; S, 13.32

Reaction of Epoxy Sulfone 70 with LDA

Epoxy sulfone 70 (600 mg; 2.5 mmole) was added to an LDA solution (75 ml THF, 3.08 mmole diisopropylamine, 3.2 mmole n-BuLi) at -78° and stirred for 24 hr at ambient temperature. After this period

the reaction mixture was quenched by addition of 10 ml of saturated ammonium chloride solution and extracted with 1X50 ml of ether, followed by 2X50 ml of methylene chloride. After drying and evaporation of the organics the crude residue was chromatographed on 50g of silica gel using 1:2 ethyl acetate/hexane as eluent. This provided 450 mg of a slightly yellow oil.

NMR:  $\delta$  1.0-1.2 (m,6H), 1.5-2.5 (m,11H), 2.7-3.2 (m,3H,2H after D<sub>2</sub>O exchange) 3.6-3.9 (m,2H), 7.5-8.1 (m,10H)

IR: OH, 3400 (broad); SO<sub>2</sub>, 1155 (s) and 1318 (s)

To 400 mg of the product(s) obtained in the above reaction in 20ml of 'spectrograde' acetone was added 4 mmole of Jones reagent. Workup provided 300 mg of an oil which was examined by NMR and IR.

NMR:  $\delta$  1.0-1.2 (m,3H), 1.8-3.0 (m,14H), 3.0-4.1 (m,3H), 7.1-8.0 (m,10H)

IR: no OH; C=O, 1715 (s) and 1745 (s); SO<sub>2</sub>, 1155 (s) and 1310 (s)

Synthesis of Non-Sulfur Containing Derivatives From the 3-Phenylcycloalkanols

Alkylation of 3-phenylcyclobutanols and -cyclopentanols

General Procedure:

A solution of the cycloalkanol was dissolved in 50 ml of freshly distilled THF at  $-70^{\circ}$  and converted to the dianion upon treatment with 2 equivalents of  $\text{CH}_3\text{Li}$ . The dianion formation was allowed to proceed for 5 min. and 1 equivalent of alkylating agent was introduced. The acetone-dry ice bath was then removed and the reaction stirred until the disappearance of starting material on the TLC. Workup was accomplished by addition of 10 ml of saturated ammonium chloride solution, followed by extraction with 1X50 ml of ether and 2X50 ml of methylene chloride. After drying and evaporation of the organics the crude products were purified by column chromatography using ethyl acetate/hexane as eluent.

3-Butyl-3-phenylsulfonylcyclobutanol 90

This compound was prepared by alkylation of the dianion of 3-phenylsulfonylcyclobutanol. This alcohol (412 mg, 1.95 mmole) was dissolved in 25 ml of THF at  $-70^{\circ}$  and treated with 3.3 ml (4.2 mmole) of  $\text{CH}_3\text{Li}$ . Excess (1 ml) of bromobutane was added and the reaction was stirred and allowed to warm to room temperature. Workup and chromatography with 1:3 ethyl acetate/hexane gave 354 mg (68%) of product 90.

NMR:  $\delta$  0.8-1.8 (m,9H), 2.4-3.0 (m,5H,4H after D<sub>2</sub>O exchange), 4.0-4.6 (m,1H), 7.4-7.9 (m,5H).

IR: OH, 3500 (broad); SO<sub>2</sub> 1120 (s) and 1310 (s)

3-Isopropyl-3-phenylsulfonylcyclobutanol 94

3-Phenylsulfonylcyclobutanol (634 mg, 3.0 mmole) was dissolved in 40 ml of THF at -70° and converted to its dianion upon addition of 4.0 ml (6.8 mmole) of CH<sub>3</sub>Li. Isopropyl iodide (0.7 ml) was then added and the reaction mixture was stirred and allowed to warm to room temperature over a 2.5 hr period, quenched with water and extracted with 50 ml of ether and 2X50 ml of methylene chloride. Further workup gave a crude product which was chromatographed on silica gel using 1:10 ethyl acetate/methylene chloride as eluent. The yield of 3-isopropyl-3-phenylsulfonylcyclobutanol as a colourless oil was 544 mg (71%).

NMR:  $\delta$  0.90 (d,J=6Hz,6H), 1.8-3.4 (m,6H), 4.1-4.6 (m,1H), 7.4-8.0 (m,5H)

IR: OH, 3480 (broad); SO<sub>2</sub>, 1140 (s) and 1300 (s)

Anal. Calcd. for C<sub>13</sub>H<sub>18</sub>O<sub>3</sub>S: C, 61.42; H, 7.09: Found C, 61.74;  
H, 7.28

3-Iodo-3-phenylsulfonylcyclobutanol 95

The yellowish dianion of 3-phenylsulfonylcyclobutanol was prepared as above from 593 mg (2.8 mmole) of sulfone alcohol and 6 mmole  $\text{CH}_3\text{Li}$  and then reacted with 406 mg (0.5 equiv.) of  $\text{I}_2$ . Usual workup gave after chromatography on 50g of silica gel (1:2 ethyl acetate/hexane) 300 mg (32%) of 3-iodo-3-phenylsulfonylcyclobutanol. m.p. 102-104°; (methylene chloride/hexane).

NMR:  $\delta$  2.6-3.4 (m,5H), 4.4-4.8 (m,1H), 7.4-8.0 (m,5H)

IR: OH, 3480 (broad);  $\text{SO}_2$ , 1140 (s) and 1300 (s)

Anal. Calcd. for  $\text{C}_{10}\text{H}_{11}\text{IO}_3\text{S}$ : C, 35.51; H, 3.26; I, 37.56 Found C, 35.23, H, 3.32; I, 37.66

3-Methylthio-3-phenylsulfonylcyclobutanol 96

The dianion from 763 mg (3.6 mmole) of 3-phenylsulfonylcyclobutanol and 7.5 mmole of  $\text{CH}_3\text{Li}$  was treated with 800 mg (excess) of dimethyl disulfide. Upon warming of the reaction mixture a yellowish solution containing a white precipitate was obtained. Workup and chromatography on 50g of silica gel using 1:3 ethyl acetate/hexane as eluent furnished 574 mg (62%) of the desired product 96.

NMR:  $\delta$  2.20 (s,3H), 2.3-3.9 (m,5H), 4.2-4.9 (m,1H), 7.4-7.8 (m,5H)

IR: OH, 3450 (broad);  $\text{SO}_2$ , 1120 (s) and 1310 (s)

3-Butyl-3-phenylsulfonycyclopentanol 91

3-Phenylsulfonycyclopentanol (789 mg; 3.5 mmole) was converted to its dianion (7.2 mmole  $\text{CH}_3\text{Li}$ ) and quenched with 520 mg (3.7 mmole) of n-butyl bromide. Workup and chromatography on 50g of silica gel (1:3 ethyl acetate/hexane) provided 781 mg (80%) of 91 as a clear oil.

NMR:  $\delta$  0.8-1.8 (m, 15H), 3.4-3.7 (m, 1H, OH), 4.2-4.6 (m, 1H), 7.4-8.0 (m, 5H)

IR: OH, 3500 (broad);  $\text{SO}_2$ , 1150 (s) and 1300 (s)

Anal. Calcd. for  $\text{C}_{15}\text{H}_{22}\text{O}_3\text{S}$ : C, 63.53; H, 7.80 Found C, 63.93, H, 7.97

3-Heptyl-3-phenylsulfonycyclopentanol 92

n-Heptyl bromide (604 mg; 3.3 mmole) was added to the dianion of the parent cycloalkanol (652 mg; 2.9 mmole 3-phenylsulfonycyclopentanol; 6.5 mmole  $\text{CH}_3\text{Li}$ ). Workup and chromatography (3:7 ethyl acetate/hexane) furnished 833 mg (88%) of the 3-heptyl derivative 92.

NMR:  $\delta$  0.8-2.8 (m, 21H), 3.4-3.6 (1H, OH), 4.2-4.6 (m, 1H), 7.4-7.9 (m, 5H)

IR: OH, 3500 (broad);  $\text{SO}_2$ , 1150 (s) and 1300 (s)

An acceptable analysis was obtained for the DNP of the corresponding cyclopentenone (see below).

3-Benzyl-3-phenylsulfonylcyclopentanol 93

The dianion of 3-phenylsulfonylcyclopentanol (457 mg; 2.0 mmole) was generated by addition of 4.4 mmole of  $\text{CH}_3\text{Li}$ . The yellow dianion was quenched at  $-70^\circ$  with 2.4 mmole of benzyl bromide. Workup and chromatography on 50g of silica gel using 2:8 ethyl acetate/hexane provided 474 mg (76%) of the 3-benzyl derivative 93.

NMR:  $\delta$  0.8-2.8 (m, 6H), 3.3-3.4 (1H, OH), 2.96 (s) and 3.04 (s) 2H,  
7.0-8.2 (m, 10H)

IR: OH, 3480 (broad);  $\text{SO}_2$ , 1110 (s) and 1310 (s)

Anal. Calcd. for  $\text{C}_{18}\text{H}_{20}\text{O}_3\text{S}$ : C, 68.35; H, 6.33 Found C, 68.17; H, 6.28

Conversion of 3-phenylsulfonylcycloalkanol into Cycloalkenones

General Procedure:

About 500 mg of the 3-phenylsulfonylcycloalkanol was dissolved in 5 ml of reagent grade acetone at room temperature and reacted with 1.1 equivalent of Jones reagent; dropwise addition over 10 min. The progress of the reaction was followed by TLC; most oxidations were complete within 30 min. Excess oxidizing agent was destroyed by addition of 10%  $\text{Na}_2\text{SO}_3$  solution. The reaction mixture was then poured into saturated  $\text{NH}_4\text{Cl}$  solution and extracted with 2X50 ml of methylene chloride. The organic layer was dried over  $\text{MgSO}_4$  and concentrated to a few ml on

a rotary evaporator. To this crude product was added about 1 ml of triethylamine. The reaction was followed by TLC. When complete, the product was isolated by washing with 2X25 ml of 5% HCl solution, drying and evaporating the organic solvent. The cycloalkenones were purified by column chromatography using 1:4 ethyl acetate/hexane as eluent.

3-Isopropylcyclobutenone 97

3-Isopropyl-3-phenylsulfonylcyclobutanol (261 mg; 1 mmole) was oxidized with 1.2 mmole of Jones reagent in 5ml of spectrograde acetone. The crude product after workup was dissolved in 5 ml of methylene chloride and treated with 2 mmole of triethylamine for 30 min. at room temperature. Usual workup followed by filtration through 20g of silica gel provided 88 mg (80%) of 97 as a clear oil.

NMR:  $\delta$  1.16 (d, J=7Hz, 6H), 2.4-3.0 (m, 1H), 3.1 (s, 2H), 5.8 (broad s, 1H)

IR: C=O, 1770 (s), C=C, 1595 (m)

3-Heptylcyclobutenone 110

This compound was obtained in 83% yield from 200 mg of 3-heptyl-3-phenylsulfonylcyclobutanol (available in these laboratories) using the same procedure as for the 3-isopropyl derivative.

NMR:  $\delta$  0.85 (m, 3H), 1.1-2.0 (m, 10H), 2.57 (t, 2H), 3.15 (s, 2H), 5.87 (s, 1H)

Attempted Diels - Alder Reaction of 110 with trans, trans-hexa-2,4-diene.

To 100 mg of 3-heptylcyclobutenone 110 in 25 ml of carbon tetrachloride at room temperature was added excess trans, trans-hexa-2,4-diene and a few drops of  $\text{BF}_3 \cdot (\text{Et}_2\text{O})_2$ . The reaction was let stir for 2 hr and then 10 ml of  $\text{H}_2\text{O}$  was added. The layers were separated and the aqueous phase was extracted with 25 ml of methylene chloride. Drying and evaporation of the organics provided a material which by NMR was identical to a mixture of the starting components.

### Cyclopent-2-enones

3-Phenylcyclopent-2-enone 98

3-Phenyl-3-phenylsulfonylcyclopentanol (340 mg; 1.1 mmole) was treated with 1.5 mmole of Jones reagent followed by 1.5 mmole of triethylamine. Usual workup followed by chromatography using 1:3 ethyl acetate/hexane provided 140 mg (75%) of 98 as a clear oil.

NMR:  $\delta$  2.5-2.7 (m, 2H), 2.9-3.2 (m, 2H), 6.52 (narrow spaced triplet, 1H),  
7.2-7.7 (m, 5H)

IR: C=O, 1690 (s); C=C, 1610 (m)

3-Benzylcyclopent-2-enone 99

This compound was obtained from 460 mg (1.4 mmole) of 3-benzyl-3-phenylsulfonylcyclopentanol, 2 mmole Jones reagent, and 2 mmole of triethylamine. Chromatography (1:4 ethyl acetate/hexane) of the crude product after workup provided 192 mg (87%) of 99 as a clear oil.

NMR:  $\delta$  2.3-2.7 (m,4H), 2.74 (s,2H), 5.88 (broad s,1H), 7.1-7.5 (m,5H)

IR: C=O, 1725 (s), C=C, 1630 (m)

3-Butylcyclopent-2-enone 101

To 550 mg (1.9 mmole) of 3-butyl-3-phenylsulfonylcyclopentanol was added 2.2 mmole of Jones reagent followed by 2.5 mmole of triethylamine after oxidation was complete. The crude product after workup was chromatographed on 20g of silica gel using 1:4 ethyl acetate/hexane as eluent, thus was obtained 101 in 86% yield.

NMR:  $\delta$  0.98 (t,J=7Hz,3H), 1.2-1.8 (m,4H), 2.3-2.8 (m,6H), 5.8-6.0 (m,1H)

IR: C=O, 1715 (s); C=C, 1630 (m)

3-Heptylcyclopent-2-enone 100

3-Heptyl-3-phenylsulfonylcyclopentanol (535 mg; 1.6 mmole) was oxidized by addition of 2 mmole of Jones reagent. The phenylsulfonyl group was removed by stirring the crude product obtained from the oxidation step with 2 mmole of triethylamine. Chromatography (1:4 ethyl acetate/hexane) of the residue after workup provided 225 mg (75%) of the enone 100.

NMR:  $\delta$  0.7-2.8 (m, 13H), 2.3-2.7 (m, 6H), 5.8-6.0 (m, 1H)

IR: C=O, 1720 (s); C=C, 1625 (m)

Calcd. for the DNP derivative.  $C_{18}H_{24}O_4N_4$ : C, 60.00; H, 6.66; N, 15.55  
Found C, 59.89; H, 6.76; N, 15.44

2-Phenylcyclopent-2-enone 102

In 10 ml of "spectrograde" acetone was dissolved 660 mg (2.2 mmole) of the cyclopentanol 81. To this was added 2.5 mmole of Jones reagent to affect oxidation and after oxidation and workup the crude product was treated with 2.5 mmole of triethylamine. Chromatography (1:3 ethyl acetate/hexane) of the crude product provided the enone 102 in 75% (260 mg) yield as white crystals, m.p. 67-68° (ether) (Lit. m.p. 71° (44)).

NMR:  $\delta$  2.3-2.6 (m, 4H), 7.1-7.2 (m, 3H), 7.3-7.5 (m, 3H)

IR: C=O, 1725 (s) (Lit. 1726 (44)).

Cyclopropyl Sulfone 117

In 200 ml of THF at  $-78^{\circ}$  was dissolved 6.8g (32mmole) of the epoxy sulfone 54 and to this was added 35 mmole of  $\text{CH}_3\text{Li}$ . The reaction mixture was allowed to warm to room temperature and then stirred at room temperature overnight. Workup was accomplished by addition of 20 ml of saturated ammonium chloride, extracting with 1X100 ml of ether and 2X100 ml of methylene chloride. The organics were combined, dried and the crude oil was chromatographed on silica gel using 3:2 ethyl acetate/hexane as eluent. The yield of clear oil was 4.5g (67%).

NMR:  $\delta$  1.0-1.7 (m,2H), 1.9-2.2 (m,1H), 2.3 (1H,OH), 3.4-3.8 (m,2H),  
7.4-8.0 (m,5H)

IR: OH, 3450 (broad);  $\text{SO}_2$ , 1120 (s) and 1310 (s)

Attempted Alkylation of 117

Cyclopropyl sulfone 117 (1 mmole) was dissolved in 20 ml of THF at  $-78^{\circ}$  and 2 mmole of  $\text{CH}_3\text{Li}$  was added. After stirring for 5 min. the reaction was quenched with  $\text{D}_2\text{O}$ . This reaction was repeated at room temperature and quenched after 15 min. with  $\text{D}_2\text{O}$ .

Other trials involved attempted generation of the dianion of 117 at room temperature and quenching with methyl iodide after 15 min. and after 30 min. In all the above cases no incorporation of the electrophile was observed as evidenced by the  $\text{PhSO}_2\text{-CH}$  ( $\delta$  2.4-2.7, m,1H) which still remained in the NMR and no methyl signal was observed after

the reactions were quenched with methyl iodide.

### Cyclobutanols 124 and 125

The desulfonylations were carried out by treating the sulfone in dry methanol, in the presence of 4 equivalents of disodium hydrogen phosphate, with excess of 6% Na-Hg amalgam at room temperature. When the reaction was complete, as evidenced by the disappearance of starting material on TLC, the reaction mixture was worked up by pouring into 20 ml of saturated NaCl solution, extracting with ether (2X50 ml), drying and evaporation of the solvent. The crude product, which contained traces of phenylsulfonic acid, was passed through 20g of silica gel (1:9 ethyl acetate/hexane).

### 3-Phenylcyclobutanol 124

From 288 mg (1 mmole) 3-phenyl-3-phenylsulfonylcyclobutanol 79 was obtained 118 mg (80%) of 124.

NMR:  $\delta$  1.7-2.9 (m, 5H, 4H after D<sub>2</sub>O exchange), 3.1-3.9 (m, 1H), 3.9-4.6 (m, 1H), 7.2 (broadened s, 5H)

IR: OH, 3500 (broad)

### 3-Benzylcyclobutanol 125

Obtained in 85% yield from 122 mg of 3-benzyl-3-phenylsulfonyl cyclobutanol 123 (available in these laboratories).

NMR:  $\delta$  1.5-2.8 (m, 5H), 4.0-4.7 (m, 1H), 7.3 (broadened s, 5H)

IR: OH, 3500 (broad)

### Stereochemistry and Mechanism

#### 3-Benzyl-3-phenylsulfonylcyclopentanol 132

In 50 ml of freshly distilled THF was dissolved 1.0g (3.2 mmole) of the epoxy sulfone 60. After cooling to  $-78^{\circ}$ , 7.6 mmole of  $\text{CH}_3\text{MgI}$  was added. The white suspension was let stir under nitrogen for 24 hr at ambient temperature. After this period the reaction mixture was poured into 100 ml of saturated ammonium chloride, extracted with 1X75 ml ether followed by 2X100 ml of methylene chloride. The organics were combined, dried and the solvent stripped. Chromatography of the residue on silica gel (3:8 ethyl acetate/hexane) provided 800 mg (80%) of the cyclopentanol 132 as a clear oil.

NMR:  $\delta$  0.8-1.1 (m, 6H), 2.96 (s, 2H), 3.2 (1H, OH), 3.7-3.9 (m, 1H),  
7.0-7.3 (m, 5H), 7.5-8.0 (m, 5H)

$^{13}\text{C}$  NMR:  $\delta$  29.1 (t), 35.8 (t), 39.4 (t), 40.8 (t), 72.9 (quaternary and doublet)

Aromatics: 135.6, 134.6, 134.0, 133.7, 130.8, 130.6, 129.2,  
129.0, 128.8, 128.5, 127.4, 126.9

X-Ray Analysis of 3-Phenyl-3-phenylsulfonylcyclobutanol ~~8~~

Suitable crystals of 79 were grown from methanol and a crystal structure determination was carried out by Dr. J. Blount at Hoffmann-LaRoche Inc., Nutley, New Jersey. A computer generated representation of the unit cell and tables of bond lengths, bond angles, selected torsion angles and the final atomic parameters are included on the following pages.

The unit cell contains two independent molecules; ie. two molecules which are unrelated by crystal symmetry (thus the problem became one of locating 40 nonhydrogen atoms instead of only 20). The two molecules were designated as unprimed and primed. The conformations of the two independent molecules are essentially the same except for a rotation of about  $15^\circ$  around the S-C(3) bond (see the torsion angles). The dihedral angles between the plane C(1)-C(2)-C(3) and the plane C(1)-C(4)-C(3) are  $32.8$  and  $32.3^\circ$  in the unprimed and primed molecules, and the dihedral angles between the planes C(2)-C(3)-C(4) and C(2)-C(1)-C(4) are  $33.2$  and  $32.8^\circ$ .

The crystals were monoclinic, space group  $P2_1/n$ , with  $a = 18.399(2)$ ,  $b = 10.607(2)$ ,  $c = 15.384(3)$  A,  $\beta = 107.24(1)^\circ$  and  $d_{\text{calcd}} = 1.335 \text{ g cm}^{-3}$  for  $Z = 8$  ( $C_{16}H_{16}O_3S$ ,  $M = 288.36$ ). The intensity data were measured on a Hilger-Watts diffractometer (Ni filtered Cu  $K\alpha$  radiation,  $\theta$ -2 $\theta$  scans, pulse height discrimination). A crystal fragment measuring approximately  $0.15 \times 0.5$  mm was used for data collection; the data were corrected for absorption ( $\mu = 19.9 \text{ cm}^{-1}$ ).

A total of 3727 reflections were measured for  $\theta < 57^\circ$ , of which 3322 were considered to be observed ( $I > 2.5\sigma(I)$ ). The structure was solved by a multiple solution procedure (G. Germain, P. Main and M. M. Woolfson, Acta Cryst. A27, 368 (1971)). The final refinement was carried out by block-diagonal least squares in which the matrix was partitioned into two blocks. In the final refinement anisotropic thermal parameters were used for the heavier atoms and isotropic temperature factors were used for the hydrogen atoms. The hydrogen atoms were included in the structure factor calculations but their parameters were not refined. The final discrepancy indices are  $R = 0.057$  and  $wR = 0.075$  for the 3322 observed reflections. The final difference map has no peaks greater than  $\pm 0.3e \text{ \AA}^{-3}$ .

Computer Generated Representation of the Unit Cell for 3-Phenyl-trans-3-phenylsulfonycyclobutanol 79

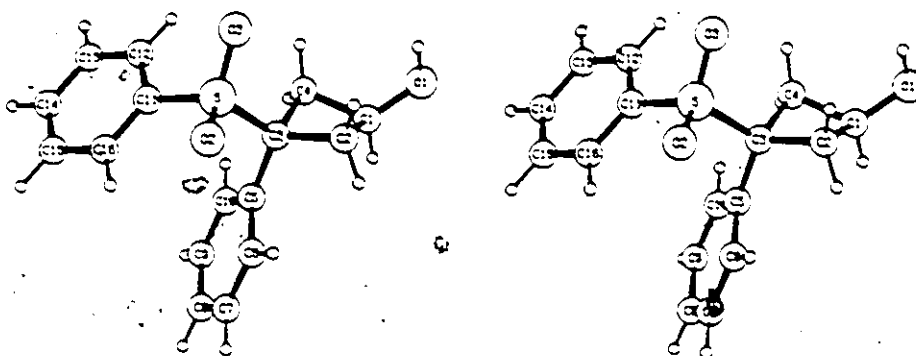

Table I. Bond Lengths (A) in

	unprimed	primed
S - O(2)	1.441	1.434
S - O(3)	1.438	1.449
S - C(3)	1.810	1.803
S -C(11)	1.764	1.764
O(1)- C(1)	1.408	1.418
C(1)- C(2)	1.537	1.524
C(1)- C(4)	1.534	1.534
C(2)- C(3)	1.556	1.558
C(3)- C(4)	1.567	1.548
C(3)- C(5)	1.502	1.522
C(5)- C(6)	1.388	1.384
C(5)-C(10)	1.386	1.394
C(6)- C(7)	1.382	1.383
C(7)- C(8)	1.361	1.358
C(8)- C(9)	1.370	1.382
C(9)-C(10)	1.375	1.412
C(11)-C(12)	1.389	1.386
C(11)-C(16)	1.384	1.383
C(12)-C(13)	1.381	1.385
C(13)-C(14)	1.368	1.381
C(14)-C(15)	1.369	1.371
C(15)-C(16)	1.393	1.393

Estimated standard deviation for a typical C-C bond length is 0.007 A.

Table II. Bond Angles ( ) in

	unprimed	primed
O(2)- S - O(3)	118.1	118.6
O(2)- S - C(3)	108.2	109.3
O(2)- S -C(11)	108.4	108.9
O(3)- S - C(3)	108.6	107.0
O(3)- S -C(11)	108.4	107.6
C(3)- S -C(11)	104.2	104.6
O(1)- C(1)- C(2)	119.1	119.6
O(1)- C(1)- C(4)	120.1	119.6
C(2)- C(1)- C(4)	89.2	89.4
C(1)- C(2)- C(3)	87.0	86.8
S - C(3)- C(2)	111.9	113.1
S - C(3)- C(4)	114.5	114.4
S - C(3)- C(5)	109.6	109.1
C(2)- C(3)- C(4)	87.4	87.6
C(2)- C(3)- C(5)	115.2	114.7
C(4)- C(3)- C(5)	116.9	116.9
C(1)- C(4)- C(3)	86.8	86.8
C(3)- C(5)- C(6)	121.0	120.1
C(3)- C(5)-C(10)	121.6	119.5
C(6)- C(5)-C(10)	117.3	120.3
C(5)- C(6)- C(7)	121.1	120.2
C(6)- C(7)- C(8)	120.7	120.1
C(7)- C(8)- C(9)	118.8	121.1
C(8)- C(9)-C(10)	121.2	119.7
C(5)-C(10)- C(9)	120.9	118.5
S -C(11)-C(12)	118.6	119.6
S -C(11)-C(16)	119.3	119.1
C(12)-C(11)-C(16)	122.1	121.4
C(11)-C(12)-C(13)	118.6	118.9
C(12)-C(13)-C(14)	119.9	120.2
C(13)-C(14)-C(15)	121.6	120.4
C(14)-C(15)-C(16)	120.1	120.5
C(11)-C(16)-C(15)	117.9	118.6

Estimated standard deviation for a typical C-C-C bond angle is 0.5 .

Table III. Torsion Angles ( ) in

	unprimed	primed
C(4)-C(1)-C(2)-C(3)	23.5	23.0
C(1)-C(2)-C(3)-C(4)	-23.0	-22.8
C(2)-C(3)-C(4)-C(1)	23.0	22.6
C(3)-C(4)-C(1)-C(2)	-23.3	-23.1
C(2)-C(3)-C(5)-C(6)	50.2	43.3
C(2)-C(3)-C(5)-C(10)	-133.7	-139.1
C(4)-C(3)-C(5)-C(6)	150.7	143.8
C(4)-C(3)-C(5)-C(10)	-33.2	-38.6
C(2)-C(3)-S-O(2)	-65.2	-78.2
C(2)-C(3)-S-O(3)	64.2	51.3
C(2)-C(3)-S-C(11)	179.6	165.3
C(3)-S-C(11)-C(12)	-82.2	-75.7
C(4)-C(3)-S-O(2)	-162.6	-176.5
C(4)-C(3)-S-O(3)	-33.2	-46.9
C(4)-C(3)-S-C(11)	82.2	67.1
C(3)-S-C(11)-C(16)	95.2	105.2

Estimated standard deviation for a typical C-C-C-C torsion angle is 0.6 .

Table IV. Final Atomic Parameters for  
with Standard Deviations in Parentheses

Atom	X	Y	Z	B
S	0.54140(5)	0.29659(10)	0.77019(7)	*
S'	0.44578(5)	0.69956(9)	0.61130(6)	*
O(1)	0.7295(2)	0.6153(3)	0.8022(2)	*
O(2)	0.4712(1)	0.3311(3)	0.7873(2)	*
O(3)	0.5473(2)	0.3147(3)	0.6799(2)	*
O(1)'	0.3410(1)	0.3857(3)	0.3883(2)	*
O(2)'	0.4605(2)	0.6867(3)	0.7078(2)	*
O(3)'	0.5047(1)	0.6632(3)	0.5713(2)	*
C(1)	0.6978(2)	0.5270(4)	0.8490(3)	*
C(2)	0.6112(2)	0.5265(4)	0.8330(3)	*
C(3)	0.6181(2)	0.3817(3)	0.8496(3)	*
C(4)	0.6936(2)	0.3872(4)	0.8225(3)	*
C(5)	0.6246(2)	0.3406(3)	0.9451(3)	*
C(6)	0.5737(3)	0.3834(5)	0.9894(3)	*
C(7)	0.5771(3)	0.3405(6)	1.0754(4)	*
C(8)	0.6297(3)	0.2532(6)	1.1182(3)	*
C(9)	0.6802(3)	0.2097(5)	1.0752(3)	*
C(10)	0.6784(2)	0.2529(4)	0.9904(3)	*
C(11)	0.5606(2)	0.1369(4)	0.8004(3)	*
C(12)	0.6129(2)	0.0730(4)	0.7676(3)	*
C(13)	0.6294(3)	-0.0510(6)	0.7932(4)	*
C(14)	0.5950(4)	-0.1075(5)	0.8507(5)	*
C(15)	0.5438(4)	-0.0443(6)	0.8835(4)	*
C(16)	0.5256(3)	0.0807(5)	0.8586(3)	*
C(1)'	0.3259(2)	0.4689(3)	0.4531(3)	*
C(2)'	0.3770(2)	0.4663(3)	0.5512(3)	*
C(3)'	0.3618(2)	0.6106(3)	0.5538(2)	*
C(4)'	0.3424(2)	0.6101(3)	0.4487(3)	*
C(5)'	0.2979(2)	0.6459(4)	0.5933(3)	*
C(6)'	0.2920(3)	0.5868(4)	0.6712(3)	*
C(7)'	0.2344(4)	0.6196(7)	0.7076(4)	*
C(8)'	0.1847(3)	0.7126(9)	0.6688(5)	*
C(9)'	0.1896(3)	0.7749(7)	0.5919(5)	*
C(10)'	0.2471(2)	0.7413(5)	0.5525(3)	*
C(11)'	0.4213(2)	0.8576(3)	0.5803(3)	*
C(12)'	0.4188(2)	0.8991(4)	0.4941(3)	*
C(13)'	0.3987(2)	1.0230(4)	0.4704(3)	*
C(14)'	0.3831(2)	1.1041(4)	0.5328(3)	*
C(15)'	0.3867(3)	1.0626(4)	0.6183(3)	*
C(16)'	0.4060(2)	0.9380(4)	0.6435(3)	*

Table IV (continued) for

Atom	X	Y	Z	B
HO(1)	0.704	0.611	0.741	6.0
H(1)	0.725	0.535	0.917	5.0
H(2)A	0.580	0.553	0.770	6.0
H(2)B	0.592	0.576	0.879	6.0
H(4)A	0.736	0.332	0.860	5.0
H(4)B	0.688	0.371	0.756	5.0
H(6)	0.535	0.449	0.959	7.0
H(7)	0.537	0.373	1.104	8.0
H(8)	0.630	0.222	1.180	8.0
H(9)	0.720	0.148	1.108	8.0
H(10)	0.716	0.220	0.960	6.0
H(12)	0.638	0.117	0.725	6.0
H(13)	0.668	-0.099	0.771	7.0
H(14)	0.608	-0.198	0.870	8.0
H(15)	0.520	-0.088	0.928	7.0
H(16)	0.487	0.129	0.882	6.0
HO(1)'	0.392	0.372	0.403	5.0
H(1)'	0.271	0.458	0.452	5.0
H(2)A'	0.431	0.443	0.559	5.0
H(2)B'	0.358	0.414	0.594	5.0
H(4)A'	0.298	0.664	0.416	5.0
H(4)B'	0.387	0.630	0.425	5.0
H(6)'	0.330	0.518	0.701	7.0
H(7)'	0.231	0.576	0.766	9.0
H(8)'	0.142	0.737	0.694	10.0
H(9)'	0.152	0.844	0.564	9.0
H(10)'	0.253	0.788	0.497	7.0
H(12)'	0.431	0.839	0.449	5.0
H(13)'	0.396	1.054	0.407	6.0
H(14)'	0.368	1.195	0.515	6.0
H(15)'	0.375	1.123	0.663	6.0
H(16)'	0.409	0.908	0.707	6.0

\* Anisotropic thermal parameters are given in Table V

Table V. Final Anisotropic Thermal Parameters for  
with Standard Deviations in Parentheses

Atom	<sup>5</sup> B11x10	<sup>4</sup> B22x10	<sup>5</sup> B33x10	<sup>5</sup> B12x10	<sup>5</sup> B13x10	<sup>5</sup> B23x10
S	214( 4)	97( 1)	435( 6)	-25( 4)	84( 3)	175( 6)
S'	207( 3)	74( 1)	412( 5)	43( 4)	69( 3)	17( 6)
O(1)	369(11)	120( 4)	545(17)	-246(15)	119(10)	98(19)
O(2)	207(10)	137( 4)	823(22)	59(14)	153(11)	244(22)
O(3)	338(11)	151( 4)	399(15)	-157(15)	68( 9)	226(19)
O(1)'	272(10)	93( 3)	498(16)	3(13)	92( 9)	-171(17)
O(2)'	380(11)	111( 3)	388(15)	50(14)	22( 9)	86(18)
O(3)'	242(10)	106( 3)	698(19)	79(13)	169(10)	-78(19)
C(1)	288(15)	88( 5)	459(23)	-63(19)	112(14)	50(25)
C(2)	292(15)	74( 4)	604(26)	83(19)	163(15)	197(26)
C(3)	195(13)	74( 4)	436(21)	60(16)	119(12)	85(22)
C(4)	218(14)	95( 5)	439(22)	-7(18)	134(13)	15(24)
C(5)	286(14)	66( 4)	404(21)	49(18)	141(13)	46(22)
C(6)	504(21)	130( 6)	709(31)	320(27)	374(21)	315(34)
C(7)	636(26)	179( 7)	677(34)	161(36)	450(24)	173(42)
C(8)	609(25)	162( 7)	481(28)	-42(34)	198(21)	201(38)
C(9)	578(24)	148( 7)	528(29)	215(31)	92(20)	325(36)
C(10)	426(18)	99( 5)	433(24)	204(23)	118(15)	123(28)
C(11)	298(15)	89( 5)	413(22)	-95(20)	50(14)	43(25)
C(12)	340(17)	109( 5)	560(28)	14(23)	51(16)	-88(31)
C(13)	520(24)	124( 7)	785(38)	131(31)	16(22)	-137(41)
C(14)	747(33)	81( 6)	969(48)	-78(34)	-94(29)	44(42)
C(15)	721(30)	121( 7)	779(39)	-282(36)	117(26)	287(41)
C(16)	486(20)	104( 5)	608(29)	-203(25)	162(18)	96(32)
C(1)'	249(14)	68( 4)	452(22)	-9(17)	128(13)	-5(23)
C(2)'	316(14)	62( 4)	432(22)	59(17)	134(13)	54(22)
C(3)'	213(13)	63( 4)	386(20)	6(16)	106(12)	26(21)
C(4)'	250(13)	72( 4)	389(21)	-11(17)	101(12)	53(22)
C(5)'	243(14)	85( 4)	506(24)	-47(19)	144(14)	-142(26)
C(6)'	415(18)	124( 6)	566(27)	-134(24)	284(17)	-148(31)
C(7)'	565(28)	222(10)	837(40)	-275(40)	453(28)	-423(49)
C(8)'	383(24)	298(13)	1080(52)	-109(44)	377(29)	-695(68)
C(9)'	330(21)	212(10)	1229(54)	305(34)	159(26)	-404(58)
C(10)'	300(17)	130( 6)	835(34)	195(25)	171(18)	-69(36)
C(11)'	197(13)	72( 4)	419(22)	-60(16)	65(12)	-35(23)
C(12)'	301(15)	81( 4)	441(23)	-102(19)	110(13)	-29(25)
C(13)'	401(17)	86( 5)	551(27)	-99(22)	97(16)	125(29)
C(14)'	383(18)	74( 5)	703(32)	-26(21)	75(18)	16(31)
C(15)'	479(20)	87( 5)	741(33)	29(24)	231(20)	-182(33)
C(16)'	421(18)	84( 5)	514(25)	-10(22)	180(16)	-76(27)

The anisotropic temperature factor has the form

$$\exp(-(\frac{h^2}{B_{11}} + \frac{k^2}{B_{22}} + \frac{l^2}{B_{33}} + 2hkB_{12} + 2hlB_{13} + 2klB_{23}))$$

Preparation of THP derivative 135

4-Phenylsulfonyl-1,2-epoxyoctane 133

4-Phenylsulfonyl-but-1-ene 53 (2.73g; 13.9 mmole) was dissolved in 40 ml of freshly distilled THF at  $-78^{\circ}$  and converted to its carbanion with 14 mmole of n-BuLi. To the yellow solution of the carbanion at  $-78^{\circ}$  was added 1.92g (14 mmole) of n-butyl bromide via syringe. The solution was let warm to room temperature and stirred for an additional hr. After usual workup the crude product was chromatographed on 50g of silica gel using 2:8 ethyl acetate/hexane as eluent, thus providing 2.50g (71%) of 4-phenylsulfonyloct-1-ene as a clear oil.

NMR:  $\delta$  0.8-2.0 (m,9H), 2.1-2.7 (m,2H), 2.8-3.2 (m,1H), 4.9-6.0 (m,3H),  
7.5-8.0 (m,5H)

IR: C=C, 1660 (m); SO<sub>2</sub>, 1140 (s) and 1320 (s)

The above compound (2.0g; 7.9 mmole) in 50 ml of methylene chloride was epoxidized to 133 by addition of 10 mmole of MCPBA followed by refluxing the reaction mixture overnight. Usual workup furnished an oil which was chromatographed on 50g of silica gel (2:8 ethyl acetate hexane). The epoxy sulfone 133 was obtained in 98% (2.1g) yield.

NMR:  $\delta$  0.8-2.2 (m,1H), 2.4-2.6 (m,1H), 2.7-2.9 (m,1H), 3.0-3.3 (m,2H),  
7.5-8.0 (m,5H)

IR: SO<sub>2</sub>, 1140 (s) and 1320 (s)

Bromohydrin 134

A three necked flask was equipped with a condenser, drying tube, and a dropping funnel. To the flask was added 389 mg (16 mmole) of magnesium metal and 50 ml of anhydrous ether. To this was added, dropwise, 3.0g (16 mmole) of dibromobutane in 10 ml of ether. After addition was complete the reaction was stirred for an additional 30 min. To this was then added 3.31g (12.3 mmole) of the epoxy sulfone 133 in 5 ml of ether, dropwise, via the dropping funnel. After stirring for 1 hr at room temperature the reaction mixture was then diluted with 50 ml of H<sub>2</sub>O and the layers were separated. The aqueous layer was then extracted with 20 ml of methylene chloride. Drying, evaporation, and chromatography (2:8 ethyl acetate/hexane) of the crude oil furnished 2.77g (70%) of the bromohydrin 134 as a clear oil.

NMR:  $\delta$  0.7-2.5 (m,1H), 3.0-3.6 (m,4H), 3.7-4.4 (m,1H), 7.5-8.0 (m,5H)

IR: OH, 3450 (broad); SO<sub>2</sub>, 1150 (s) and 1310 (s)

THP Derivative 135

In 25 ml of methylene chloride was dissolved 2.50g (7.6 mmole) of the bromohydrin 134, 1.30g (15.0 mmole) of 2,3-dihydropyran and 1 drop of trifluoroacetic acid. The mixture was let stir at room temperature for 2 days (complete by TLC). The solution was then concentrated on the rotary evaporator and chromatographed using 2:8 ethyl acetate/hexane.

The yield of 135, as a clear oil, was 87% (2.74g).

NMR:  $\delta$  0.8-1.0 (m,3H), 1.1-2.4 (m,14H), 3.0-4.2 (m,6H), 4.4-5.1 (m,1H),  
7.5-8.0 (m,5H)

IR: no OH; SO<sub>2</sub>, 1150 (s) and 1310 (s)

Treatment of 135 with CH<sub>3</sub>MgI

The THP derivative 135 (1 mmole) was dissolved in freshly distilled THF and varying amounts of CH<sub>3</sub>MgI were added. Three runs, 1 equiv., 2.5 equiv., and 3 equiv., with reaction times ranging from 1-7 days. The only products observed by NMR were starting material and halide exchanged starting material.

Preparation of THP derivative 139

Iodohydrin 138

Treatment of 4.0g (18.8 mmole) of epoxy sulfone 54 in 100 ml of THF at -78° with 20 mmole of CH<sub>3</sub>MgI followed by warming to room temperature and quenching with 20 ml of saturated ammonium chloride solution provided, after usual workup, 5.4g (85%) of the iodohydrin 138, m.p. 88-89° (methylene chloride/hexane).

NMR:  $\delta$  1.6-2.3 (m,2H), 2.6 (broad,1H,OH), 3.2-3.4 (m,4H), 3.5-3.9 (m,1H), 7.4-8.0 (m,5H)

$^{13}\text{C}$  NMR:  $\delta$  13.8 (t), 29.4 (t), 69.0 (d)

Aromatics 127.9, 129.4, 133.9

IR: OH, 3480 (broad);  $\text{SO}_2$ , 1150 (s) and 1310 (s)

Anal. Calcd. for  $\text{C}_{10}\text{H}_{13}\text{O}_2\text{SI}$ : C, 35.30; H, 3.82; S, 9.41 Found C, 36.51,  
H, 4.03; S, 9.58

THP derivative 139

In 50 ml of methylene chloride was dissolved 5.11g (15.03 mmole) of the iodohydrin 138 and 200 mg of para-toluene sulfonic acid. To this solution at room temperature was added 2.52g (30 mmole) of 2,3-dihydropyran. The mixture was stirred until starting material had disappeared on TLC (30 hr). The mixture was then diluted with 50 ml of  $\text{H}_2\text{O}$  and the layers were separated. The aqueous layer was then extracted with 50 ml of methylene chloride. The organics were combined, dried, and the solvent removed. Chromatography of the resultant yellow oil (2:8 ethyl acetate/hexane) furnished 5.0g (78%) of the THP derivative 139.

NMR:  $\delta$  0.8-2.7 (m,8H), 2.9-4.2 (m,7H), 4.3-4.9 (m,1H), 7.0-7.9 (m,5H)

IR: no OH;  $\text{SO}_2$ , 1150 (s) and 1310 (s)

Reaction of 139 with  $\text{CH}_3\text{MgI}$

In 100 ml of freshly distilled THF was added 1.33g (3.13 mmole) of 139. The solution was cooled to  $-78^\circ$  and 6.3 mmole of  $\text{CH}_3\text{MgI}$  in ether was added. A white precipitate formed immediately upon addition of the Grignard reagent. The reaction was then allowed to warm to room temperature and stirred for an additional 24 hr. NMR and TLC analysis of the reaction mixture after workup indicated that only starting material was present.

Hydrolysis of the reaction product with 5% HCl/methanol provided the iodohydrin 138 (80%).

The reaction was repeated with 3 and 4 equivalents of Grignard reagent with reaction times varying from 24 hr to 4 days. No cyclized material was observed.

In one run the reaction mixture from 3.6 mmole THP derivative and 9 mmole  $\text{CH}_3\text{MgI}$  was quenched after 24 hr with 3.6 mmole of benzophenone. Chromatography of the reaction mixture (2:8 ethyl acetate/hexane) gave the starting THP derivative (90%) and 600 mg (85%) of 1:1 diphenylethanol 140.

NMR:  $\delta$  1.80 (s,3H), 2.3 (1H,OH), 6.7-7.2 (m,10H)

Synthesis of Cyclobutyl Phenyl Sulfone

1-bromo-4-phenylsulfonylbutane 141

In 100 ml of absolute ethanol, was dissolved 20.0g (92.6 mmole) of 1,4-dibromobutane and 16.0g (97.5 mmole) of sodium phenylsulfinate. The solution was then refluxed for 24 hr, cooled and 200 ml of H<sub>2</sub>O was added. The resulting solution was extracted with 2X100 ml methylene chloride and the organic extracts were dried and the solvent stripped on the rotary evaporator. The remaining ethanol was removed by azeotropic distillation with benzene. Chromatography of the crude material (1:3 ethyl acetate/hexane) furnished 4.6g (18%) of the bromosulfone 141 as white needles, m.p. 58-59°C (methylene chloride/hexane).

NMR:  $\delta$  1.7-2.1 (m,4H), 3.12 (t,J=6Hz,2H), 3.36 (t,J=6Hz,2H), 7.4-7.9 (m,5H)

M.S.	<u>Fragment</u> m/e	<u>Rel. Abundance</u>	<u>Assignment</u>
	276, 278	<1%	M <sup>+</sup>
	197	3.8	[ M-HBr ] <sup>+</sup>
	135, 137	30	[ M-SO <sub>2</sub> Ph ] <sup>+</sup>
	77	38	Ph <sup>+</sup>
	55	100	[ C <sub>4</sub> H <sub>7</sub> ] <sup>+</sup>

Reaction of 141 with 1 equivalent of  $\text{CH}_3\text{MgI}$

In 25 ml of freshly distilled THF was dissolved 332 mg (1.2 mmole) of the bromosulfone 141. The solution was cooled to  $-78^\circ$  and 1.5 mmole of  $\text{CH}_3\text{MgI}$  was added. A white precipitate formed immediately. The solution was let warm to room temperature and stirred for a further 12 hr. After this time the solution was poured into saturated ammonium chloride and extracted with 1X50 ml ether, followed by 1X50 ml methylene chloride. Drying and evaporation of the combined organic extracts furnished a solid which was analyzed by  $^1\text{H}$  NMR. The following approximate product distribution was found.

$\text{PhSO}_2\text{-C}_4\text{-I}^*$	70
$\text{PhSO}_2\text{-C}_4$	18
$\text{PhSO}_2\text{-C}_4\text{-CH}_3$	10

\* recrystallation of the crude reaction mixture furnished a pure sample of the iodo sulfone which was identical in all respects to an authentic sample.

1-Iodo-4-phenylsulfonylbutane 142

In 30 ml of "spectrograde" acetone was dissolved 3.0 g (10.8 mmole) of the bromosulfone 141 and 1.8g (12 mmole) of sodium iodide at room temperature. The solution was stirred for 12 hr, poured into 100 ml of  $\text{H}_2\text{O}$  and then extracted with 2X50 ml of methylene chloride. Evaporation of the solvent from the dried organic extracts

furnished a solid material which was recrystallized from methylene chloride/hexane yielding 2.9g (83%) of 142 as white needles. m.p. 74-75°.

NMR:  $\delta$  1.7-2.1 (m,4H), 3.0-3.3 (m,4H), 7.5-8.0 (m,5H)

M.S.	Fragment m/e	Rel. Abundance	Assignment
	324	<1%	M <sup>+</sup>
	197	54	[ M-I ] <sup>+</sup>
	143	60	[ PhSO <sub>2</sub> H <sub>2</sub> ] <sup>+</sup>
	77	66	Ph <sup>+</sup>
	55	100	[ C <sub>4</sub> H <sub>7</sub> ] <sup>+</sup>

Reaction 142 with 1 equivalent of CH<sub>3</sub>MgI

In 25 ml of freshly distilled THF was dissolved 380 mg (1.17 mmole) of the iodosulfone 142. To this solution at -78° was added 1.5 mmole of CH<sub>3</sub>MgI. The solution was let warm to room temperature and stirred overnight. Usual workup afforded an oily substance whose NMR qualitatively indicated the following product distribution.

PhSO <sub>2</sub> -C <sub>4</sub>	45
PhSO <sub>2</sub> -C <sub>4</sub> -I	45
PhSO <sub>2</sub> -C <sub>4</sub> -CH <sub>3</sub>	5 - 10

Reaction of 142 with 2 equivalents of  $\text{CH}_3\text{MgI}$

The iodosulfone 142 (1.34g; 4.1 mmole) was dissolved in 25 ml of freshly distilled THF. The solution was cooled to  $-78^\circ$  (dry ice - acetone) and 10 mmole of  $\text{CH}_3\text{MgI}$  was added. This solution was let warm to room temperature and then stirred for 24 hr. The reaction mixture was then poured into 50 ml of saturated ammonium chloride and extracted with 1X50 ml ether followed by 1X50 ml methylene chloride. The organic extracts were combined, dried and the solvent stripped thus providing a crude oil which was chromatographed on 40g of silica gel using 1:9 ethyl acetate/hexane. The yield of cyclobutyl phenylsulfone 143 was 90% (700 mg).

NMR:  $\delta$  1.8-2.6 (m,6H), 3.56 (quintet;  $J=8\text{Hz}$ ,1H), 7.4-7.9 (m,5H)

$^{13}\text{C}$  NMR:  $\delta$  16.8 (t), 22.8 (t), 56.9 (d)

Aromatics 128.2, 129.2, 133.5

2 Equivalents vs. 1 Equivalent in the Grignard Induced Cyclization  
of Epoxy Sulfone 54

Epoxy sulfone 54 was treated, in parallel runs, with 1 equivalent (run A) and 2 equivalents (run B) of  $\text{CH}_3\text{MgI}$ . The Grignard reagent was standardized just prior to use.

Run A In 25 ml of anhydrous THF was dissolved 507 mg (2.4 mmole) of the epoxy sulfone 54. The solution was cooled to  $-78^\circ$  and stirred under nitrogen. To this solution was added 2.4 mmole of  $\text{CH}_3\text{MgI}$ . The progress of the reaction was followed by taking 1 ml aliquots (via syringe) of the reaction mixture at various times and examining the  $^1\text{H}$  NMR spectrum. The reaction mixture was let warm to room temperature.

Run B The same procedure, as in Run A, was followed except for the following modifications. The epoxy sulfone (485 mg; 2.3 mmole) was dissolved in 25 ml of THF, cooled as above and 5.7 mmole of  $\text{CH}_3\text{MgI}$  was added.

The above reactions were allowed to stir for 52 hr at ambient temperature and are then quenched with 10 ml of saturated ammonium chloride solution. Upon quenching the reaction mixtures gas evolution was observed in both cases. The results are presented in Table VI.

PART II

Benzhydryl Phenyl Sulfone 17

To 150 ml of glacial acetic acid containing 25% concentrated sulfuric acid was added 4.0g (22 mmole) of diphenylmethanol and 3.8g (23 mmole) of sodium phenylsulfinate. After stirring at room temperature for 5 hr the solution was diluted with 500 ml of H<sub>2</sub>O, and extracted with 2X100 ml of methylene chloride. The organic extracts were then treated with 10% Na<sub>2</sub>CO<sub>3</sub> solution until the aqueous phase was rendered basic. The organics were then dried and the solvent evaporated. Chromatography (1:4 ethyl acetate/hexane) of the residue furnished 5.2g (76%) of the sulfone 17. m.p. 185-186° (Lit. m.p. 187-188° (16)).

NMR:  $\delta$  5.30 (s, 1H), 7.0-7.8 (m, 15H)

IR: SO<sub>2</sub>, 1140 (s) and 1300 (s)

Reaction of 17 with CH<sub>3</sub>Li/O<sub>2</sub>

In 200 ml of anhydrous THF at room temperature was dissolved 947 mg (3.07 mmole) of the sulfone 17. To this solution was added 3.5 mmole of CH<sub>3</sub>Li. The reddish solution of the carbanion was stirred for 20 min. at room temperature and then O<sub>2</sub> was introduced via a gas

dispersion tube. The red colour disappeared within 5 min. Oxygen was then bubbled through the solution for a further 45 min. after which time the reaction mixture was poured into 50 ml of saturated ammonium chloride and worked up in the usual manner. Chromatography of the residue remaining after evaporation of the solvent provided 420 mg (75%) of benzophenone which was identical in all respects to an authentic sample. m.p. 44-45° (Lit. m.p. 48.1° (17)).

Reaction of 17 with  $\text{CH}_3\text{Li}/\text{S}_8$

The sulfone 17 (3.66g; 11.5 mmole) was dissolved in 200 ml of freshly distilled THF at -78°. To this solution was added 12.8 mmole of  $\text{CH}_3\text{Li}$  and the solution was stirred for 15 min. at -78° after which time 2.9g (11.5 mmole) of  $\text{S}_8$  was added. The solution became greenish blue immediately and after 30 min. at ambient temperature the solution became dark blue. After stirring for an additional 30 min. the solution was quenched with 50 ml of saturated ammonium chloride and then extracted with 1X50 of ether followed by 2X50 ml of methylene chloride. The organics were combined, dried and the solvent was removed on the rotary evaporator. The blue solid was allowed to stand in the air for 24 hr after which time the colour has disappeared and 2.03g (95%) of benzophenone was recovered.

$\alpha$ -Methylbenzyl Phenyl-Sulfone 23

In 100 ml of glacial acetic acid containing 25% concentrated

sulfuric acid was dissolved 6.0g (36.5 mmole) of sodium phenylsulfinate and 4.5g (37 mmole) of phenethyl alcohol. The solution was stirred at room temperature for 6 hr and then diluted with 400 ml of H<sub>2</sub>O. The solution was then extracted with 2X100 ml of methylene chloride. The organic extracts were then treated with 10% Na<sub>2</sub>CO<sub>3</sub> solution until the aqueous phase was found to be basic. The resultant crude solid was chromatographed on 200g of silica gel (1:8 ethyl acetate/hexane) thus was provided 7.5g (78%) of the sulfone 23. m.p. 106-108°.

NMR:  $\delta$  1.76 (d, J=6Hz,3H), 4.20 (q, J=6Hz,1H), 6.9-7.6 (m,10H)

IR: SO<sub>2</sub>, 1120 (s) and 1310 (s)

Reaction of 23 with CH<sub>3</sub>Li/O<sub>2</sub> and BF(OMe)<sub>2</sub>/H<sub>2</sub>O<sub>2</sub>

Treatment of 23 (747 mg; 2.8 mmole) with 3 mmole of CH<sub>3</sub>Li followed by introduction of O<sub>2</sub> (1 run at -78° and 1 run at 0°) yielded a product which was identical to starting material (TLC and NMR).

Treatment of 23 (1 mmole) with excess BF(OMe)<sub>2</sub>/H<sub>2</sub>O<sub>2</sub> gave a product which, by NMR, showed no acetophenone. No acetophenone was detected by TLC.

cis 4-t-Butylcyclohexyl Phenyl Sulfone 24

Available in these laboratories, m.p. 113-114° (chromatographed on silica gel with 1:4 ethyl acetate/hexane), (Lit. m.p. 115-116° (18)).  
NMR:  $\delta$  .87 (s,9H), 1.3-2.6 (m,8H), 2.8-3.2 (m,1H), 7.4-8.0 (m,5H)

Treatment of the carbanion of 24 (generated from 1 mmole of 24 and 1.2 mmole  $\text{CH}_3\text{Li}$ ) with  $\text{O}_2$  at room temperature or  $-78^\circ$  gave after quenching only epimerized starting material by NMR. No cyclohexanone was detected by TLC or NMR.

The carbanion of 24, when treated with excess  $\text{BF}(\text{OMe})_2/\text{H}_2\text{O}_2$ , gave intractable material. Once again, no cyclohexanone was observed.

Benzyl Phenyl sulfone 25

Reaction of 25 with  $\text{CH}_3\text{Li}/\text{O}_2$

At  $-78^\circ$

The carbanion of 25 (1.4 mmole 25, 1.6 mmole  $\text{CH}_3\text{Li}$ ) when treated with  $\text{O}_2$  at  $-78^\circ$  for 1 hr gave, after quenching, and workup, a product which was mainly starting material (95%). Benzaldehyde was detected by NMR (5%), TLC and by its distinctive odor.

At Room Temperature

The yellow carbanion of 25 was generated by addition of 4.5

mmole of  $\text{CH}_3\text{Li}$  to 1.0g (4.3 mmole) of 25 at room temperature.  $\text{O}_2$  was introduced into the solution for 1 hr during which time the solution became clear. Quenching with  $\text{H}_2\text{O}$  followed by usual workup provided the hydroxy sulfone 26 in 85% yield.

NMR:  $\delta$  4.2-4.5 (m, 2H, 1H after  $\text{D}_2\text{O}$  exchange), 5.6-6.1 (m, 1H), 6.7-7.8 (m, 15H)

IR: OH, 3450 (broad);  $\text{SO}_2$ , 1120 (s) and 1300 (s)

Treatment of a solution of the carbanion of 25 (1.5 mmole) containing 1.6 mmole cupric chloride also gave only the adduct 26 as evidenced by NMR.

Reaction of the carbanion of 25 with  $\text{S}_8$  gave 5% starting material and unidentified products while treatment with  $\text{BF}(\text{OMe})_2$  gave tar like substances.

#### Sulfonamide 27

To a two phase system containing excess aqueous dimethylamine (25-30% by wt.) and 25 ml of chloroform was added 1.4g (7.6 mmole) of benzylsulfonyl chloride. The solution was stirred at room temperature for 2 hr and then poured into 200 ml of  $\text{H}_2\text{O}$ . Workup afforded 1.2g (79%) of the sulfonamide 27. m.p.  $99^\circ$  (Lit. m.p.  $100-101^\circ$  (19)).

NMR:  $\delta$  2.70 (s, 6H), 4.06 (s, 2H), 7.23 (s, 5H)

Reaction of Sulfonamide 27 with  $\text{CH}_3\text{Li}/\text{O}_2$

To 680 mg (3.4 mmole) of the sulfonamide 27 at  $-78^\circ$  was added 3.6 mmole  $\text{CH}_3\text{Li}$ . After stirring for 20 min.  $\text{O}_2$  was introduced for 1.5 hr at  $-78^\circ$  and the reaction mixture was then quenched with 5 ml of saturated ammonium chloride. Usual workup and examination of the NMR of the crude product revealed that mainly starting material (80%) was present. No benzaldehyde was detected.

The above experiment (724 mg; 2.1 mmole 27, 2.2 mmole  $\text{CH}_3\text{Li}$ ) was also carried out at room temperature. A result identical to the above was obtained.

Benzyl Phenyl Sulfoxide 29

Available in these laboratories, m.p.  $120-121^\circ$  (Lit. m.p.  $122-123^\circ$  (20)).

NMR:  $\delta$  4.00 (s, 2H), 6.8-7.5 (m, 10H)

Reaction of 29 with  $\text{CH}_3\text{Li}/\text{O}_2$

The  $\alpha$ -sulfinyl~~carbanion~~ carbanion of 29 was generated by treatment of 29 (631 mg; 2.9 mmole) with 2.9 mmole  $\text{CH}_3\text{Li}$  at  $-78^\circ$  under nitrogen. The solution of the carbanion was stirred for 20 min. at  $-78^\circ$  and  $\text{O}_2$  was passed through the solution for 1 hr. After this period the reaction mixture was quenched with  $\text{D}_2\text{O}$  followed immediately by 20 ml of saturated ammonium chloride. The NMR of the product, after usual

workup, revealed that incorporation of deuterium  $\alpha$  to the sulfoxide was essentially complete as judged by the integration of the NMR spectrum.

NMR:  $\delta$  4.0 (broadened triplet, 1H), 6.7-7.8 (m, 10H)

PART III

Dibenzyl Sulfone 4

Available in these laboratories, m.p. 147-148° (methylene chloride/pentane) (Lit. m.p. 150° ( 9 )).

2,6-Diphenylthiàne-1,1-dioxide 1

To 200 ml of freshly distilled THF, under nitrogen, was added 4.38g (43 mmole) of diisopropylamine. This solution was cooled to -78° and 46 mmole of CH<sub>3</sub>Li was added slowly via syringe. The solution was stirred for 20 min. at -78° and then 4.84g (19 mmole) of dibenzyl sulfone 4 was added. After 15 min. at -78°, 3.14g (20 mmole) of bromo chloropropane was added. The resultant solution was let warm to room temperature and then stirred overnight. The solution was then quenched with H<sub>2</sub>O and extracted with 1X50 ml of ether followed by 2X50 ml of methylene chloride. The organics were combined, dried and the solvent stripped. The crude solid was chromatographed on silica gel using 2:8 ethyl acetate/hexane as the eluent. The white crystalline sulfone 1 was obtained in 80% yield. m.p. 217-218° (methylene chloride/pentane).

NMR: δ 1.5-2.9 (m,6H), 4.16 (dd, J=11.9 and 3.1Hz, 2H), 7.2-7.6 (m,10H)

IR: SO<sub>2</sub>, 1120 (s) and 1300 (s)

$^{13}\text{C}$  NMR:  $\delta$  70.3 (d), 34.3 (t), 27.9 (t)

Aromatics 134.6, 132.2, 130.4

Anal. Calcd. for  $\text{C}_{17}\text{H}_{18}\text{O}_2\text{S}$ : C, 71.33; H, 6.29 Found C, 71.50;  
H, 6.19

Synthesis of 4-t-Butylthiane-1,1-dioxide 3

Diester 5

To a freshly prepared ether solution of  $\text{CH}_3\text{MgI}$  (11g; 450 mmole Mg and 64g; 450 mmole  $\text{CH}_3\text{I}$ ) was added a solution of 80g of isopropylidene in 50 ml of anhydrous ether, dropwise over 2 hr. The reaction mixture was then stirred for an additional 4 hr after which time 200 ml of saturated ammonium chloride were added slowly over 20 min. This solution was then extracted with 2X100 ml of ether. The extracts were combined, dried and the ether removed on the rotary evaporator. Distillation of the resultant liquid furnished 60g (71%) of the diester 5. (b.p. 98-102°, medium vacuum pump)..

NMR:  $\delta$  1.06 (s,9H), 1.27 (t,J=6Hz,6H), 3.00 (s,1H), 4.12 (q,J=6H,4H)

Diol 6

In a 250 ml round bottomed flask equipped with a condenser and drying tube was suspended 9.5g (250 mmole) of  $\text{LiAlH}_4$ . To this suspension was added a solution of 42g (194 mmole) of the diester 5 in

50 ml of anhydrous ether, dropwise at 0°. After addition was complete, the solution was refluxed for 2 hr and then worked up in the manner described in Feiser and Feiser (10). Evaporation of the ether provided 21g (82%) of the diol 6 after distillation. b.p. 89-95°, 50<sub>mm</sub>

NMR:  $\delta$  1.10 (s,9H), 1.5-1.9 (broad, 1H), 3.5-3.9 (m,6H,4H after D<sub>2</sub>O exchange)

IR: OH, 3500 (broad)

#### Dimesylate 7

In 200 ml of methylene chloride was dissolved 46g (456 mmole) of triethylamine and 25g (190 mmole) of the diol 6. The solution was cooled to ice temperature and a solution of 418 mmole methanesulfonyl chloride (freshly distilled) in 50 ml methylene chloride was added dropwise over a 1 hr period. The reaction mixture was stirred for 2 hr and then 100 ml of H<sub>2</sub>O was added slowly. The organic layer was drawn off and the aqueous layer was then extracted with 2X100 ml of methylene chloride. The organic extracts were combined, washed with 100 ml of 5% HCl, dried and the solvent removed furnishing 52g (94%) of the dimesylate 7.

NMR:  $\delta$  1.10 (s,9H), 1.7-2.0 (m,1H), 3.02 (s,6H), 4.2-.45 (m,4H)

Dinitrile 8

The crude mesylate (85g, 90% by NMR) was dissolved in 300 ml of DMSO and 32.5g (0.5 mole) of potassium cyanide was added. The solution was heated at 100° for 48 hr during which time the reaction mixture turned black. After this period 300 ml of H<sub>2</sub>O were added and the solution was extracted with 2X100 ml of methylene chloride. The organic layers were combined, dried and evaporated. The resultant crude oil was distilled, thus was furnished 18g (45%) of the dinitrile 8.  
b.p. 100-105°, 5μ.

NMR: δ 1.00 (s, 9H), 1.7-2.0 (m, 1H), 2.5 (d, J=5Hz, 4H)

IR: C≡N, 2210 (m)

Diacid 9

The dinitrile 8 (22g; 146 mmole) was refluxed in excess concentrated HCl (sp. gr. 1.18) for 4 hr. The reaction mixture was then diluted with 100 ml of H<sub>2</sub>O and extracted with 2X100 ml of methylene chloride. The organic extracts were combined and the solvent stripped. The crude product was dissolved in excess 5% NaOH and the aqueous layer was washed with 100 ml of ether. The basic extracts were reacidified and the diacid was recovered by extraction with 200 ml of ether, which upon drying and evaporation of the solvent furnished 22g (81%) of the diacid 9.

NMR:  $\delta$  .95 (s,9H), 2.1-2.6 (m,5H), 10.5 (broad,2H)

Diol 10

In 150 ml of anhydrous ether was suspended 15g (400 mmole) of  $\text{LiAlH}_4$ . To this suspension at  $0^\circ$  was added 21g (111 mmole) of the diacid 9 in 100 ml of ether. After addition was complete, the reaction was refluxed for 3 hr. Usual workup gave the diol 10 in 86% (15g) yield.

NMR:  $\delta$  .9 (s,9H), 1.1-2.1 (m,5H), 3.3-3.8 (m,6H)

$\text{D}_2\text{O}$  exchange  $\delta$  3.66, (t, J=6Hz, 4H)

IR: OH, 3400 (broad)

Dimesylate 11

In 200 ml of methylene chloride was dissolved 23g (220 mmole) of triethylamine and 15g (94 mmole) of diol 10. To this solution at  $0^\circ$  was added 24g (210 mmole) of freshly distilled methanesulfonyl chloride dropwise over a 1 hr period. The solution was then diluted with 100 ml of  $\text{H}_2\text{O}$  and worked up in the usual manner. The yield of dimesylate 11 was 24g (95%).

NMR:  $\delta$  .90 (s,9H), 1.1-2.3 (m,5H), 2.96 (s,6H), 4.18 (t, J=6Hz, 4H)

IR: no OH

#### 4-t-Butylthiane 12

To a solution of 25g (79 mmole) of the dimesylate 11 dissolved in 100 ml of 95% ethanol was added 34g of sodium sulfide nonahydrate. The solution was refluxed overnight and then worked up by addition of 100 ml of saturated ammonium chloride and extracted with 2X100 ml of methylene chloride. The organics were dried and the solvent stripped. The crude oil was purified by distillation. Thus was obtained 8.0g (52%) of 12. b.p. 60-62°, 2u.

NMR:  $\delta$  .90 (s,9H), 1.0-2.0 (m,5H), 2.3-2.6 (m,4H)

#### 4-t-Butylthiane-1,1-dioxide 3

The sulfide 12 (3.5g; 22 mmole) was dissolved in 100 ml of methylene chloride and to this solution at room temperature was added 10.0g (60 mmole) of MCPBA in several portions over a 1 hr period. After an additional hr at reflux the solution was cooled to room temperature and washed with 2X50 ml of 5% NaOH. Extraction with 2X100 ml of methylene chloride followed by drying and evaporation of the organics yielded 4.0g (95%) of the sulfone 3. m.p. 108° (methylene chloride/pentane).

NMR:  $\delta$  .95 (s,9H), 1.1-2.4 (m,5H), 2.8-3.2 (m,4H)

IR: SO<sub>2</sub>, 1110 (s) and 1310 (s)

<u>M.S.</u>	<u>Fragment m/e</u>	<u>Rel. Abundance</u>	<u>Assignment</u>
	190	10	$\overline{M}^+$
	175	75	$[M-CH_3]^+$
	134	92	$[M-C_4H_7]^+$
	57	100	$[C_4H_9]^+$

Reactions of the  $\alpha$ -sulfonyl carbanion of 2,6-diphenylthiane-1,1-dioxide  
1 and 2 with electrophiles

H<sub>2</sub>O

The carbanion of the cis isomer 1 was generated in THF by reaction of 1 with 1.1 equivalents of CH<sub>3</sub>Li. The reaction was worked up by quenching the reaction mixture with H<sub>2</sub>O followed by extraction with 1X50 ml of ether and 2X50 ml of methylene chloride. The individual trials are summarized below.

<u>Temperature</u>	<u>Time</u>
-78°	1 min.
0°	1 min.
0°	15 min.
R.T.	1 min.
R.T.	40 hr.

The only product observed after workup in all the above cases was the trans 2,6-diphenylthiane-1,1-dioxide 2. m.p. 153-154° (methylene chloride/pentane).

NMR:  $\delta$  1.8-2.2 (m,2H), 2.2-2.9 (m,4H), 4.30 (dd,J=7.2 and 4.2Hz,2H),  
7.3-7.8 (m,10H)

IR: SO<sub>2</sub>, 1120 (s) and 1310 (s)

<sup>13</sup>C NMR:  $\delta$  23.4 (t), 32.6 (t), 67.2 (d)  
Aromatics 135.9, 132.2, 130.4

Trans 2,6-diphenylthiane-1,1-dioxide (1 mmole) when converted to its carbanion with CH<sub>3</sub>Li and quenched with H<sub>2</sub>O regenerated only starting material under all the reaction conditions listed below.

<u>Temperature</u>	<u>Time</u>
-78°	1 min.
-78°	2 min.
-78°	2 hr
0°	5 min.
R.T.	1 hr

D<sub>2</sub>O

The carbanion of the cis isomer 1 was generated at -78° from 179 mg (.63 mmole) of the sulfone 1 and .70 mmole of CH<sub>3</sub>Li. The reaction mixture was stirred for 10 min. at -78° and then quenched with D<sub>2</sub>O. Usual workup provided a product which was examined by <sup>1</sup>H NMR.

NMR: δ 1.8-2.3 (m,2H), 2.3-2.9 (m,4H), 4.20 (broadened triplet,1H),  
7.2-7.8 (m,10H)

In 20 ml of THF at -78° the trans isomer 2 (62mg; .22 mmole) was treated with .26 mmole of CH<sub>3</sub>Li and quenched with D<sub>2</sub>O. Usual workup provided a product which was identical (TLC and NMR) to the product obtained by quenching the carbanion of the cis isomer with D<sub>2</sub>O.

CH<sub>3</sub>I

The cis isomer 1 (25.9mg; .9 mmole) was treated, at -78° in THF, with 1.1 mmole of CH<sub>3</sub>Li. The solution was stirred for 2 min. at -78° and then quenched with excess CH<sub>3</sub>I. Usual workup provided 90% of a product 13 which showed incorporation of 1 methyl group.

NMR: δ 1.70 (s,3H), 1.7-2.9 (m,6H), 3.93 (dd,J=12 and 3Hz, 1H),  
7.2-8.0 (m,10H)

Treatment of the trans sulfone 2 (93mg; .32 mmole) under the same conditions as above provided the same product (TLC and NMR) as was obtained above.

The product 13 obtained above (100mg; .33 mmole) was refluxed overnight in MeOH/NaOMe. Usual workup provided 85mg (85%) of a crystalline material which was recrystallized from methylene chloride/hexane. m.p. 204-205°

NMR:  $\delta$  1.97 (s,3H), 1.5-3.0 (m,6H), 4.3 (dd,J=12.5 and 3.2Hz,1H),  
7.2-7.8 (m,10H)

$^{13}\text{C}$  NMR:  $\delta$  20.9, 21.3, 31.3, 34.8, 63.5, 68.4

Aromatics 135.9, 130.9, 130.2, 130.0, 128.9, 128.4, 128.2

$^{13}\text{C}$  NMR of  $\alpha$ -lithio-4-t-Butylthiane-1,1-dioxide 3

A  $^{13}\text{C}$  NMR tube was fitted with a septum cap and two needles, one as a nitrogen inlet and the other as an outlet. The tube was purged with nitrogen and 103 mg (.54 mmole) of the sulfone 3 was placed in the tube. To this was added 1 ml of THF- $d_8$  from a freshly opened ampule. This solution was then cooled in a dry ice-acetone bath to -78° and .54 mmole of  $\text{CH}_3\text{Li}$  was added with a micro syringe. The tube was then slowly warmed to room temperature and the septum cap was replaced with a plastic tube cap. The  $^{13}\text{C}$  NMR was then recorded and the results are presented on pg.127.

After the  $^{13}\text{C}$  NMR was recorded, the solution in the NMR tube was cooled to ice temperature and excess  $\text{CH}_3\text{I}$  was added. The reaction mixture was then poured into  $\text{H}_2\text{O}$  and extracted with 1X25 ml of methylene chloride. Drying and evaporation of the organics provided an 88% recovery of the  $\alpha$ -methyl derivative.

NMR:  $\delta$  .9S (s,9H), 1.2-2.2 (m,SH), 2.7-3.2 (m,3H)

REFERENCES

PART I

1. R.E. Parker and N.S. Isaacs, Chem. Rev., 59, 737 (1959)
2. J.G. Pritchard and T.H. Siddiqui, J. Chem. Soc., Perkin II, 1309 (1972)
3. N.S. Enikolopiyan, Pure App. Chem. 48, 317 (1976)
4. J.E. Baldwin, J.C.S. Chem. Comm., 734 (1976)
5. A.C. Knipe and C.J.M. Stirling, J. Chem. Soc., (B), 67 (1968)
6. L. Tenud, S. Farooq, J. Seibl and A. Eschenmoser, Helv. Chim. Acta, 53, 2059 (1970)
7. G. Stork, L.D. Cama and R.D. Coulson, J. Am. Chem. Soc., 96, 5268 (1974)
8. G. Stork and J.F. Cohen, J. Am. Chem. Soc., 96, 5270 (1974)
9. R. F. Sauers, R.A. Parent and S.B. Samle, J. Am. Chem. Soc., 88, 2257 (1966)
10. J.Y. Lallemand and M. Onanga, Tetrahedron Lett., 585 (1975)
11. R. Achini and W. Oppolzer, Tetrahedron Lett., 369 (1975)
12. M. Kodama, Y. Matsuki and S. Ito, Tetrahedron Lett., 3065 (1975)
13. M. Kodama, Y. Matsuki and S. Ito, Tetrahedron Lett., 1121 (1976)
14. M. Kodama, S. Yakoo, H. Yamoda and S. Ito, Tetrahedron Lett., 3121 (1978)
15. V. Rautenstrauch, J.C.S. Chem. Comm., 519 (1978)
16. Y. Gaoni, Isr. J. Chem., 63 (1971)

17. V.N. Yandovski and B.A. Ershov, Russ. Chem. Rev., 41, 403 (1972)
18. P.A. Cruickshank and M. Fishman, J. Org. Chem., 34, 4060 (1969)
19. Y. Gaoni, Tetrahedron, 28, 5525 (1972)
20. Y. Gaoni, Tetrahedron, 28, 5533 (1972)
21. G. Hodgson, D.F. MacSweeney and T. Money, Tetrahedron Lett., 3683 (1972)
22. J. Babler and A. Tortorello, J. Org. Chem., 41, 885 (1976)
23. A. Turcant and M. Lecarre, Tetrahedron Lett., 789 (1977)
24. C.R. Johnson, J.E. Keiser and J.C. Sharp, J. Org. Chem., 34, 860 (1969)
25. R.J. Shultz; W.H. Staas and L.A. Spurlock, J. Org. Chem., 38, 3091 (1973)
26. L.A. Spurlock and R.G. Fayter Jr., J. Am. Chem. Soc., 94, 2707 (1972)
27. N.R. Williams, Advan. in Carbohyd. Chem., 25, 109 (1970) and references therein
28. M.C. Sacquet, B. Graffe and P. Maitte, Tetrahedron Lett., 4453 (1972)
29. A. Murai, M. Ono and T. Masamune, J.C.S. Chem. Comm., 864 (1972)
30. T. Masamune, M. Ono, S. Sato and A. Murai, Tetrahedron Lett., 371 (1978)
31. Y. Gaoni, Tetrahedron Lett., 503 (1976)
32. B. Corbel and T. Durst, J. Org. Chem., 41, 3648 (1976)
33. Leo Paquette in "Modern Heterocyclic Chemistry", Chapter 1, W.A. Benjamin, Inc., Reading, 1968.
34. E.J. Corey and J.W. Suggs, Tetrahedron Lett., 2647 (1975)

35. M.S. Hatch, J. Org. Chem., 34, 2133 (1969)
36. L.R. Feiser and M. Feiser, "Reagents for Organic Synthesis", Vol. 1, p. 430, John Wiley and Sons, New York, 1967
37. K. Kondo and D. Tunemoto, Tetrahedron Lett., 1007 (1975)
38. M. Julia and B. Badet, Bull. Soc. Chim. Fr., 1363 (1975)
39. W.A. Bonner and R.A. Grimm in "The Chemistry of Organic Sulfur Compounds", Vol. 2, p. 115; Pergamon Press, Oxford, 1966
40. W.E. Truce, D.P. Tate and P.N. Burdge, J. Am. Chem. Soc., 82, 2872 (1960)
41. G.H. Posner and D.J. Brunelle, Tetrahedron Lett., 935 (1973)
42. B.M. Trost, H.C. Arndth, P.E. Stage and T.R. Verhoeven, Tetrahedron Lett., 3477 (1976)
43. H.E. Baumgarten (Ed), Organic Synthesis, Vol. 5, p. 310, John Wiley and Sons, Inc., New York, N.Y., 1973
44. Y. Amiel, A. Loffler and D. Ginsburg, J. Am. Chem. Soc., 76, 3625 (1954)
45. E.J. Corey, Ann. N.Y. Acad. Sci., 180, 24 (1971)
46. J.B. Sieja, J. Am. Chem. Soc., 93, 2481 (1971)
47. H. Wasserman, J.U. Piper and E.V. Dehmlow, J. Org. Chem., 38, 1451 (1973)
48. H. Mayr and R. Huisgen, Angew. Chem. Int. Ed. Engl., 14, 499 (1975)
49. T.R. Kelly and R.W. McNutt, Tetrahedron Lett., 285 (1975)
50. H. House "Modern Synthetic Reactions", 2nd Ed., p. 643, W.A. Benjamin Inc., Menlo Park, Calif., 1972

D

51. E. Ritchie and W.C. Taylor, Aust. J. Chem., 24, 2137 (1971)
52. P.C. Conrad and P.L. Fuchs, J. Am. Chem. Soc., 100, 346 (1978)
53. Y. Chang and H.W. Pinnick, J. Org. Chem., 43, 373 (1978)
54. B.M. Trost, Private Communication
55. W.A. Kerr and C.R. Johnson, J. Am. Chem. Soc., 92, 4979 (1970)  
and references therein
56. M.S. Kharasch and O. Reinmouth, "Grignard Reactions of Non-Metallic Substances", p. 1297, Prentice-Hall, New York, N.Y., 1954
57. A. Marquet, Private Communication
- ~~58.~~ B. Corbel, Private Communication
59. R.L. Shriner, H.C. Struck and W. Jorison, J. Am. Chem. Soc.,  
52, 2066 (1930)
60. Beilstein, 6455

PART II

1. E. Muller and T. Toppel, Chem. Ber., 72, 273 (1939)
2. D.A. Konen, L.S. Silbert and P.E. Pfeffer, J. Org. Chem., 40, 3253 (1957)
3. E. Vedejs, J. Am. Chem. Soc., 96, 5944 (1974)
4. W. Adam and O. Cueto, J. Org. Chem., 42, 38(1977).
5. S.J. Selikson and D.J. Watt, J. Org. Chem., 40, 267 (1975)
6. H.H. Wasserman and B.H. Lipschutz, Tetrahedron Lett., 1731 (1975)
7. G. Rauchswalbe and M. Schlosser, Helv. Chim. Acta., 58, 4 (1975)
8. T.C. Brilkina and V.A. Shustunov, "Reactions of Organic Compounds with Oxygen and Peroxides", Chemical Rubber Publishing Co., Cleveland, Ohio, 1969
9. C. Walling and S. Buckler, J. Am. Chem. Soc., 77, 6032 (1955)
10. G.A. Russell, Adv. Chem. Ser., 51, 112 (1965); 75, 174 (1968)
11. E.J. Panek, L.R. Kaiser and G.M. Whitesides, J. Am. Chem. Soc., 99, 3708 (1977)
12. A. Schoberl and A. Wagner in Houben-Weyl, "Method der Organischen Chemie", p. 250, Thieme Verlag, Stuttgart, 1955
13. D. Seebach, Angew. Chem.; Int. Ed. Engl., 9, 639 (1969)
14. R. Mayer, Synthesis and Properties of Thiocarbonyl Compounds, in M.J. Janssen (Ed.) "Organosulfur Chemistry", Interscience Publ., New York, 1967
15. S. Oae, "Organic Chemistry of Sulfur", Plenum Press, New York, 1977

16. F.G. Bordwell and B.M. Pitt, J. Am. Chem. Soc., 77, 572 (1955)
17. CRC Handbook of Chemistry and Physics, 51st Ed., The Chemical Rubber Co., Cleveland, Ohio, 1970
18. E.L. Eliel and R.S. Ro, J. Am. Chem. Soc., 79, 5995 (1957)
19. L.A. Paquette and M. Rosen, Tetrahedron Lett., 703 (1967)
20. Beilstein 6(1), 225

PART III

1. R. Legault and T. Durst, Private Communication
2. J.B. Stothers, "Carbon-13 NMR Spectroscopy", p. 411, Academic Press, New York, N.Y., 1972
3. T. Durst, Tetrahedron Lett., 4171 (1971)
4. E.L. Eliel, A.A. Hart and A.G. Abatjoglou, J. Am. Chem. Soc., 96, 1087 (1974)
5. E.J. Corey and T.H. Lowry, Tetrahedron Lett., 793 (1965)
6. D.J. Cram and A.S. Wingrove, J. Am. Chem. Soc., 85, 1100 (1963)
7. S. Wolfe, A. Rauk and I.G. Csizmadia, J. Am. Chem. Soc., 91, 1567 (1969)
8. G. Chassaing and A. Marquet, Tetrahedron, 34, 1399 (1978)
9. Beilstein 6, 456

CLAIMS TO ORIGINAL RESEARCH

1. Corbel's initial results on  $\gamma$ -epoxy sulfone cyclization have been extended to include a variety of  $\delta$ -epoxy sulfones.

2. All  $\delta$ -epoxy sulfones studied yield only 3-phenylsulfonyl cyclopentanol derivatives on treatment with 2 equivalents of  $\text{CH}_3\text{MgI}$ . Some unexpected results were obtained in the case of the reaction of  $\delta$ -epoxy sulfones with LDA.

3. Both 3-phenylsulfonylcyclobutanol and 3-phenylsulfonyl cyclopentanol were readily alkylated  $\alpha$  to the sulfone group via dianion formation followed by quenching with an electrophile.

4. Several 3-phenylsulfonylcyclobutanols and -cyclopentanols were prepared via a "one-pot" process.

5. 3-alkyl-cyclopent-2-enones were readily obtained from 3-phenylsulfonylcyclopentanol derivatives by an oxidation/elimination sequence.

6. It has been established that both 3-phenylsulfonyl cyclobutanol and -cyclopentanol formation is stereospecific. In one instance an X-ray structure determination showed that the hydroxyl and phenylsulfonyl groups occupy a cis relationship to each other. Furthermore, NMR analysis suggests that all 3-phenylsulfonyl cycloalkanols prepared by the Grignard route belong to the same stereochemical series.

7. Several cyclobutanols were generated by treatment of 3-phenylsulfonylcyclobutanols with  $\text{Na(Hg)}$  amalgam.

7  
8. Several aspects of the mechanism of the Grignard induced epoxy sulfone cyclization have been studied. It was shown that 2 equivalents of Grignard reagent are required to promote cyclization.

9. The oxidation of various sulfur-stabilized carbanions was attempted with several types of reagents such as  $O_2$ ,  $S_8$  and  $BF(OMe)_2$ . Oxidation of  $\alpha$ -lithio benzhydryl phenyl sulfone was found to proceed smoothly upon treatment with  $O_2$  or  $S_8$ . The reaction with  $S_8$  may constitute a potential method for the synthesis of diaryl thioketones.

10. The  $\alpha$ -sulfonyl carbanion of 2,6-diphenylthiane-1,1-dioxide was shown to react with electrophiles in a stereospecific manner with incorporation of the electrophiles ( $H_2O$ ,  $D_2O$ ,  $CH_3I$ ) in the equatorial position of the ring.