



National Library
of Canada

Acquisitions and
Bibliographic Services Branch

395 Wellington Street
Ottawa, Ontario
K1A 0N4

Bibliothèque nationale
du Canada

Direction des acquisitions et
des services bibliographiques

395, rue Wellington
Ottawa (Ontario)
K1A 0N4

Your file / Votre référence

Our file / Notre référence

NOTICE

The quality of this microform is heavily dependent upon the quality of the original thesis submitted for microfilming. Every effort has been made to ensure the highest quality of reproduction possible.

If pages are missing, contact the university which granted the degree.

Some pages may have indistinct print especially if the original pages were typed with a poor typewriter ribbon or if the university sent us an inferior photocopy.

Reproduction in full or in part of this microform is governed by the Canadian Copyright Act, R.S.C. 1970, c. C-30, and subsequent amendments.

AVIS

La qualité de cette microforme dépend grandement de la qualité de la thèse soumise au microfilmage. Nous avons tout fait pour assurer une qualité supérieure de reproduction.

S'il manque des pages, veuillez communiquer avec l'université qui a conféré le grade.

La qualité d'impression de certaines pages peut laisser à désirer, surtout si les pages originales ont été dactylographiées à l'aide d'un ruban usé ou si l'université nous a fait parvenir une photocopie de qualité inférieure.

La reproduction, même partielle, de cette microforme est soumise à la Loi canadienne sur le droit d'auteur, SRC 1970, c. C-30, et ses amendements subséquents.

UNIVERSITY OF OTTAWA

AN ANALYSIS OF PARTITIONS AND STRATA IN CHARLES IVES'S
THREE PLACES IN NEW ENGLAND

by

Robert McKee Frayne

DEPARTMENT OF MUSIC

Presented to the Faculty of Arts
in partial fulfillment of the requirements
for the degree of Master of Music



National Library
of Canada

Acquisitions and
Bibliographic Services Branch

395 Wellington Street
Ottawa, Ontario
K1A 0N4

Bibliothèque nationale
du Canada

Direction des acquisitions et
des services bibliographiques

395, rue Wellington
Ottawa (Ontario)
K1A 0N4

Your file / Votre référence

Our file / Notre référence

The author has granted an irrevocable non-exclusive licence allowing the National Library of Canada to reproduce, loan, distribute or sell copies of his/her thesis by any means and in any form or format, making this thesis available to interested persons.

L'auteur a accordé une licence irrévocable et non exclusive permettant à la Bibliothèque nationale du Canada de reproduire, prêter, distribuer ou vendre des copies de sa thèse de quelque manière et sous quelque forme que ce soit pour mettre des exemplaires de cette thèse à la disposition des personnes intéressées.

The author retains ownership of the copyright in his/her thesis. Neither the thesis nor substantial extracts from it may be printed or otherwise reproduced without his/her permission.

L'auteur conserve la propriété du droit d'auteur qui protège sa thèse. Ni la thèse ni des extraits substantiels de celle-ci ne doivent être imprimés ou autrement reproduits sans son autorisation.

ISBN 0-315-80000-3

Canada



UNIVERSITÉ D'OTTAWA
UNIVERSITY OF OTTAWA

TABLE OF CONTENTS

LIST OF FIGURES	iv
LIST OF TABLES	v
LIST OF EXAMPLES	vi
LIST OF ABBREVIATIONS.....	vii
ABSTRACT.....	ix
1. BACKGROUND TO <u>THREE PLACES IN NEW ENGLAND</u> ...	1
Introduction.....	1
Existing Research.....	3
Influences on Ives's Style.....	7
<u>Three Places In New England</u>	14
2. <u>PARTITIONING CRITERIA FOR THREE PLACES</u> <u>IN NEW ENGLAND</u>	20
A Theory of Partitioning.....	20
Partitioning Parameters.....	23
Silence.....	23
Repetition.....	24
Rhythm.....	26
Pattern completion.....	27
Orchestration and texture.....	29
Tonality.....	30
Scale resources.....	32
Number of strata.....	32
Proportional Schemes.....	33
Kinetic Aspects of Form.....	34

3. FORM IN THREE PLACES IN NEW ENGLAND:
 AN OVERVIEW..... 36

Kinetic Increases..... 37

Phrases and Form..... 42

Phrase Structure in
 "The 'St. Gaudens' in Boston Common".... 43

Phrase Structure in "Putnam's Camp, Redding,
 Connecticut"..... 48

Phrase Structure in "from The Housatonic at
 Stockbridge"..... 52

4. PARTITIONS AND STRATA IN "FROM THE HOUSATONIC
 AT STOCKBRIDGE"..... 57

Three Partitions..... 57

Parametric Changes at Partition 1 (E-1).... 60

Parametric Changes at Partition 2 (G-1).... 61

Parameter Changes at Partition 3 (J+1)..... 64

Common Parametric Changes among
 Partitions 1, 2, and 3..... 66

Proportional Form 68

Rhythmic Strata 72

Rhythmic Strata at Partitions 1 and 2..... 73

Rhythmic Strata at Partition 3..... 77

Harmonic Strata at Partitions 1 and 2..... 80

Strata and Partitions of "The 'St. Gaudens'
 in Boston Common" and "Putnam's Camp,
 Redding, Connecticut"..... 82

5. CONCLUSIONS.....	86
Findings.....	86
Issues and Problems in Determining Partitions and Strata.....	89
Future Research.....	91

Appendix

1. PREFACES TO <u>THREE PLACES IN NEW ENGLAND</u>	94
2. NOTES ON THE <u>FOURTH VIOLIN SONATA</u>	97
3. <u>MISSIONARY CHANT AND DORRANCE</u>	98

A SELECTED BIBLIOGRAPHY OF CHARLES IVES AND HIS MUSIC,
WITH AN EMPHASIS ON ANALYTICAL/THEORETICAL STUDIES.. 99

OTHER THEORETICAL STUDIES CONSULTED..... 103

COLLECTIONS, MODERN EDITIONS, RECORDINGS..... 104

LIST OF FIGURES

2.1	Phrase-form in the B-section of "Putnam's Camp, Redding, Connecticut"...	33
3.1	Overall form in <u>Three Places In New England</u>	36
3.2	Common formal elements in <u>Three Places In New England</u>	38
3.3	Phrase-form in "The 'St. Gaudens' in Boston Common".....	47
3.4	Phrase-form in "Putnam's Camp, Redding, Connecticut".....	50
3.5	Phrase-form in "from The Housatonic at Stockbridge".....	53
4.1A	Partitions in "from The Housatonic at Stockbridge".....	58
4.1B	Relative weights of the partitions in "from The Housatonic at Stockbridge".....	58
4.2	Proportional form in "from The Housatonic at Stockbridge".....	69
4.3	Rhythmic strata at partition 1.....	74
4.4	Rhythmic strata at partition 2.....	75
4.5	Rhythmic strata at partition 3.....	79
4.6	Harmonic strata at partition 1.....	81
4.7	Harmonic strata at partition 2.....	82
4.8	Principle strata in "The 'St. Gaudens' in Boston Common" and "Putnam's Camp, Redding, Connecticut".....	83

LIST OF TABLES

1.1	<u>Three Places In New England</u> and comparable works.....	16
2.1	Partitioning parameters.....	22
3.1	Phrase lengths in <u>Three Places In New England</u>	51
4.1	Parametric changes at the significant partitions in "from The Housatonic at Stockbridge".....	59
4.2	R-values for strata at partitions 1 and 2.....	76

LIST OF EXAMPLES

2.1	"The 'St. Gaudens' in Boston Common" (B)...	23
2.2	Themes (incipits) in the A-section of "Putnam's Camp, Redding, Connecticut"...	25
2.3	"Putnam's Camp, Redding, Connecticut" (H-2 to H+2).....	26
2.4	"Putnam's Camp, Redding, Connecticut" (G-6 to G).....	29
2.5	Close and distant modulations in "Putnam's Camp, Redding, Connecticut"...	31
3.1	High loudness locations with pc densities in <u>Three Places In New England</u>	41
3.2	Thematic sources of A-themes in "The 'St. Gaudens' in Boston Common"....	45
3.3	The A-theme in "from The Housatonic at Stockbridge," <u>Dorrance</u> , and <u>Missionary Chant</u>	54
3.4	A and A ¹ themes in "from The Housatonic at Stockbridge".....	55
3.5	Strata at (G+1) in "from The Housatonic at Stockbridge".....	55
4.1	Theme A at partition 1 versus at (A).....	60
4.2	Theme A at partition 2 versus at (A+1).....	62
4.3	Theme A at partition 3 versus at (A).....	64
4.4	A harmonic reduction of partition 3.....	65
4.5	Changes in the number of pitch-classes at three partitions in "from The Housatonic at Stockbridge".....	67

LIST OF ABBREVIATIONS

- (A) = rehearsal-letter A. Indicates a location in the score.
- (A+1) = rehearsal-letter A plus one bar. Indicates a location in the score.
- b. 3 = beat 3. Indicates a location within a bar.
- bb. 3-4 = beats 3 to 4, inclusive. Indicates a location within a bar.
- f(N) = transformation factor of "N". Indicates a ratio among metric subdivisions--such as $R(4):R(2)=f_2$ (for example, whole notes to half notes are at f_2).
- int. = introductory or introduction. Describes a preliminary musical passage, that leads into a main thematic statement.
- m. = measure, as in m. 23 (measure 23)
- mm. = measures, as in mm. 23-25 (measures 23 to 25, inclusive), or 15 mm. = 15 measures (in length).
- pc = pitch-class. A pitch class encompasses all pitches that are octave or enharmonic equivalents (for example, C^1 , c^3 , and $b\#^2$ all belong to the same pitch class).

pitch designations:

C_1 --- B_1 C --- B c --- b c^1 --- b^1 c^2 --- b^2 c^3 --- b^3 c^4

R-value = a ratio of metric subdivision per measure.

R(N) = R-value "N." Indicates a subdivision ratio of "N" units per measure, as in R(2) (=2 units per measure ; for example, 2 half-notes per measure in common time).

tN = transposition by "N.". Indicates that a given pitch is transposed by "N" semitones (for example, C at t3 = E^b).

ABSTRACT

Three Places in New England contains formal partitions and strata at these partitions. The way Ives organizes musical elements at partitions reveals some of his compositional and structural techniques. Analytic procedures that I employ include developing and applying criteria to various musical parameters that affect partitions. The presence of many simultaneous changes within several musical parameters--or a few major changes--indicates a partition.

Comprehensive and systematic observation of the music at partitions is carried out so that the prominent rhythmic and harmonic collections (strata) can be identified. This study is specifically directed towards strata in "from The Housatonic at Stockbridge."

The strata may be organized according to their respective rhythmic, harmonic, or other appropriate characteristics; in other words, into individually analyzable components. The effect of stratification of musical features, especially similar cohesive features, is a characteristic "Ivesian" trademark.

By focusing on partitions, and identifying strata at these points and how they are interrelated, some compositional and structural principles of Ives's style emerge. These principles, utilized by Ives, include (1) tonal

reference to chords, scales and (occasionally) progressions in a highly chromatic background, (2) proportional schemes of formal organization of subdivisions within pieces (and a less structured organization of phrase lengths), and (3) the use of passages that have tendencies towards multiple and simultaneous (increased or decreased) parametric changes.

CHAPTER 1

BACKGROUND TO THREE PLACES IN NEW ENGLAND

Introduction

In this study I examine Three Places in New England in order to determine the important formal partitions, and strata at these partitions.¹ The way in which Ives organizes musical elements at partitions will reveal some of his compositional and structural techniques. The analytic procedures that I employ include developing and applying criteria to various musical parameters that affect partitions. The initial approach to locating partitions consists of identifying phrases and their patterns or organizational schemes; the boundaries of phrases create the

¹Gage Canadian Dictionary, (1983), s.v. "strata" and "partition." In Gage strata (plural) or stratum (singular) is defined as "a horizontal layer of material, especially one of several parallel layers placed one upon another." In this thesis strata means a musical layer--where elements share one or more characteristics (strata are discussed in chapter 4). These characteristics include timbre, register, pitch, rhythmic pattern, or a repeated device such as an ostinato. For example, a repeated rhythmic pattern of a C-chord could be a discrete stratum. Further discussion of strata follows in chapter 4. A "partition," also from Gage, is something that separates; especially a thin inside dividing wall or membrane--in this thesis partitions denote formal boundaries.

partitions. Further, the presence of many simultaneous changes within several musical parameters--or a few drastic changes--also indicates a partition. While I shall examine the whole of Three Places in New England, the third piece, "from The Housatonic at Stockbridge," will serve as the main source to illustrate details of partitioning and stratification.

The strata may be separated according to their respective rhythmic, harmonic, or other appropriate characteristics; in other words, into individually analyzable components. The effect of stratification is a characteristic Ivesian "collage."² As Burkholder writes,

An important aspect of Ives's mature music is its organization into layers, after representing several simultaneous streams of musical thought, which are arranged into a hierarchy according to their importance or prominence.³

In this study, I define the partitions and types of strata therein, and also focus on how strata are related. We will see that strata in Ives's music are connected either linearly or vertically. Surface examples of connecting relationships among strata include Ives's frequent use of successive and simultaneous quotations and themes, often by means of multiple ensemble (several tunes, orchestras, or

²Peter Burkholder, "The Evolution of Charles Ives's Music: Aesthetics, Quotation, Technique" (Ph. D. diss., University of Chicago, 1983), 472. "Collage," as used by Burkholder, refers to "layers of quotes."

³Ibid., 494.

bands portrayed at once), and dense counterpoint or large pitch-class (pc) collections. Individual strata defined by form, rhythm, harmony, and orchestration often combine to create an extremely dense texture that is a trademark of Ives's music. By focusing on partitions, and identifying strata at these points, some compositional and structural principles of Ives's style will emerge.

The thesis engages the following questions about Ives's music, and Three Places In New England in particular; is this music tonal or atonal? is it structured or unstructured? and, how is it to be analyzed?

I shall demonstrate that Three Places In New England is structured, as evident in Ives's handling of form--regular and organized arrangements of sections and discrete strata, each based on harmonic or rhythmic cohesion.

Existing Research

Theoretical and analytical literature devoted to Ives's music features both mathematical and conventional approaches. Mathematical and post-tonal analyses are as follows; set-theoretic and atonal analytic procedures have been applied by Forte, computer model transformational-techniques of analysis by Gingerich, and symmetrical-construction analysis of both interval-cycles and pitch-aggregates by Lambert.⁴ It is my

contention that, although these techniques are useful, they do not readily address the difficulties of formal and polyrhythmic classification in Ives's music.

More conventional analyses are found in works by Alan Stein and Russel Albert; both composers.⁵ Alan Stein looks for unity, often based on interval selection; he is concerned with the minor and major thirds and their permutations, as well as their structural roles in Three Places in New England. Stein also examines simpler rhythmic ratios, Ives's philosophical reasons for implementing a "program" for each piece, and ways by which motives and quotations are developed and interrelated. Russel Albert compares harmonic analysis of the Concord Sonata versus the "philosophical intent" behind

⁴Allen Forte, "Ives and Atonality," chap. in An Ives Celebration, ed. Hugh Wiley Hitchcock and Vivian Perlis (Urbana, Chicago, London: University of Illinois Press, 1977); Lora L. Gingerich, "A Technique for Melodic Motivic Analysis in the Music of Charles Ives," Music Theory Spectrum 8 (1986): 75-93; Philip Lambert "Intervallic Cycles as Compositional Resources in the Music of Charles Ives," Music Theory Spectrum 12 (1990):43-82; Philip Lambert "Aggregate Structures in the Music of Charles Ives," Journal of Music Theory 34, no. 1, (spring 1990): 29-56.

⁵Alan Stein, "The Musical Language of Charles Ives's Three Places in New England" (D.M.A. diss., University of Illinois, 1975); Russel Albert, "The Harmonic Language of Charles Ives's Concord Sonata" (D.M.A. diss., University of Illinois, 1974). Both Albert and Stein share a "philosophical" approach, and these dissertations are analysis-adjuncts to their doctorates in composition--Stein's is much longer and more of a "theory" paper, versus the transcendental focus of Albert towards Emerson and Thoreau.

this piece.⁶ He presents "functional harmonic" analyses of selected sections and intervallic and pitch-cell-based analyses of others. Albert expands upon Ives's theme of substance (an idea or message) transcending manner (or style-the medium) as an explanation for Ives's creation of unconventional, yet convincingly communicative music, especially in the Concord Sonata. The affixed bibliography lists most sources of research on Ives concerning Three Places in New England in particular and his music in general. There are a total of 55 dissertations (to 1988) and articles (to 1990).⁷ None is directed towards a stratified analysis of musical features at formal partitions.

Much musicological research focuses upon the historical, biographical, and philosophical context of Ives's music. Of this research, a clear musicological and theoretical overview is found in articles and books by Peter Burkholder; he has made a comprehensive study of Ives's use of quotations. For background on Ives and his quotation usage, see the Burkholder dissertation of 1983.⁸ The first half of this dissertation is published as a book entitled Charles Ives:

⁶Ives discusses his philosophy and its relationship to music in Essays Before A Sonata (New York: Norton, 1962).

⁷A complete listing of writing about Ives is found in: Geoffrey Block, Charles Ives: A Bio-Bibliography (New York, Westport Connecticut, London: Greenwood Press, 1988).

⁸Burkholder, Evolution.

The Ideas behind the Music;⁹ the second half is relevant to formal partitions and their strata--especially chapter 10, "Layering and Articulation, Process and Form" (which is awaiting publication by Yale University Press). In chapter 10, Burkholder provides examples of harmonic separation.¹⁰ A clear picture of antecedents to Ives is also found in Charles Ives: The Ideas Behind The Music where, in addition to the musicological/philosophical context, examples from "from The Housatonic at Stockbridge" show different types of paraphrase--one of Burkholder's main interests.

One study relevant to the topic of strata-at-partitions, for Ives, is William Brooks's "Unity and Diversity in Charles Ives's Fourth Symphony,"¹¹ where "sectional diversity and lamination made from many coextensive layers of material (seven)"¹² are examined in the first movement of Ives's Fourth Symphony. Brooks develops a theory of connected webs of different types of layers--from musical parameters--and tunes. X/y and network graphs, with some segmentation of related components, illustrate this theory. Brooks focuses on

⁹Peter Burkholder, Charles Ives: The Ideas behind the Music, (New Haven: Yale University Press, 1985).

¹⁰Burkholder, "Evolution," 535; this example of harmonic strata consists of parallel horizontal lines.

¹¹William Brooks, "Unity and Diversity In Charles Ives's Fourth Symphony," Yearbook for Inter-American Research 10 (1974): 5-49.

¹²Ibid., 24.

how different perceptions of the listener allow a different emphasis or trriage of the many layers present. He declares, "It is obvious that each layer in the families we have outlined is unified by a particular technical device," and then summarizes how these devices are obscured.¹³

My method of analysis goes beyond the Brooks and Burkholder research by providing, first, more details of formal partitioning, and second, more information about the rhythmic and harmonic construction of strata at partitions.

Influences on Ives's Style

Stylistic influences on Charles Ives are both musical and extra-musical. Extra-musical influences are less tangible but nonetheless important. The relationship between the motivating inspirations for Three Places In New England and the resulting musical program is summarized in chapter 3. Spiritual influences upon Ives include the Transcendentalism of Thoreau and Emerson,¹⁴ William Phelps¹⁵ (Ives's literature professor) and Harmony Ives (his well-read wife and

¹³Ibid., 38-41. Brooks accounts for "harmonic families of layers" in Ives's Fourth Symphony.

¹⁴As in Joseph Reed's Three American Originals. (Middletown, CT.: Wesleyan Univ. Press, 1984), in which Reed draws parallels between transcendentalism and Ives's music. Primary sources that treat Ives and Transcendentalism include Ives's Essays Before a Sonata and Memos.

¹⁵William Phelps (1865-1943) is known as a critic of American literature.

occasional lyricist). Ives's writings are an interesting complement to his music; for example, Essays Before A Sonata, intended to be read before hearing the Concord Sonata, presents Ives's view of the aesthetics of music.

In addition, Ives was isolated from the musical mainstream, because of demands imposed by his career in the life-insurance business and his ill health after 1906; he had a weak heart. This isolation was coupled with a lack of acceptance of his music by most musicians and the public, caused by Ives's idiosyncratic, and challenging, style.

The musical influences vary and are of two types: (1) traditional tonal influences--which gave Ives his grounding in tonal and formal organizational skills, and (2) experimental and personal influences--which motivated Ives to write in his own unique and expressive style. Tonal antecedents include George Ives (his father), Horatio Parker (his music instructor at Yale), and such 19th-century music that Ives heard. Experimental antecedents include John Griggs (the choir master at New Haven), New England musical forms (hymns, brass band music, popular songs, and ragtime) and at least some ideas from other composers of the time (as provided in popular sources such as Contemporary Composers).¹⁶

¹⁶According to his reading list in his diary of 1919 Ives read Contemporary Composers by Daniel Gregory Mason, New York, 1918. For more information see Burkholder, Ideas, 110-111.

Charles Ives learned much about music from his father. George Ives (1845-1894) was the "youngest bandmaster in the Union Army."¹⁷ He was also Charles's first music teacher. After hearing Charles play rhythmically at the piano, George Ives sent his six-year-old to study drum rudiments with the local barber (the drummer in George's brass band--whom Charles replaced, on occasion, beginning at age 12).¹⁸ George taught Charles music theory, including a polytonal harmonization of "London Bridge," counterpoint, some music of Bach and Stephen Foster, and music history (biography of Beethoven). Charles also arranged and composed for his father's band (marches incorporating Son of a Gambolier, Annie Lisle and My Old Kentucky Home).¹⁹ Above all, as Charles Ives himself states, he learned from Ives Sr. "an open-minded approach to sound,"²⁰ experimenting with "stacking of more

¹⁷New Grove Dictionary of Music and Musicians 1st ed., s.v. "Ives, Charles," by John Kirkpatrick.

¹⁸Burkholder, Ideas, 42-57, and for more information on Charles Ives's "early music training"; also Charles Ives, Memos (New York: Norton and Son, 1972), 42-43 re: "piano-drumming": "In practising the drum parts on the piano...notes...were used only as sound-combinations."

¹⁹George Ives had studied music in New York with Carl Foeppel, according to "Ives, Charles," by John Kirkpatrick. For "London Bridge," in simultaneous keys, see the Charles Ives exercise books at the Ives collection at Yale; consult Kirkpatrick's catalogue for the appropriate carton. These exercises are also mentioned in Maynard Solomon, "Charles Ives: Some Questions of Veracity," Journal of the American Musicological Society 40 (fall 1987):443-470.

than three thirds, wide melodic leaps, microtones, [and] scales without octaves,"²¹ and an early disposition to imitate sounds: "George Ives joining his sons playing train in the yard, by playing along on his [presumably George Ives's] violin, simulating car wheel sounds with staccato passages and arpeggios".²² Other experiments included "piano-drumming," designed to combine snare drum rudiments with non-specific piano pitches,²³ and the use of quotation: Slow March (written c. 1887) uses Dead March (from Handel's Saul) and Waltz, (written c. 1894) quotes Little Annie Rooney.

While in Danbury, Charles became a church organist at age 14, playing the standard hymn repertoire as well as writing some conventional-tonal choral and organ music. He was also influenced by the revivalist music heard at camp meetings, as attested by his program notes for Violin Sonata No.4 "Children's Day at the Camp Meeting."²⁴

²⁰See Charles Ives, Memos, 114 and throughout, as Charles idolized his father and frequently mentions him. Solomon suggests that these references to his father are contrived to explain the source of Charles's isolationist genius. Memos is the only primary source, as yet, detailing George Ives's musical genius and it is difficult to know how much musical versus emotional influence George Ives really had on his son.

²¹Memos, 44-45, 120, 142.

²²From a "miscellaneous diary," Ives Collection, at Yale. Series V, box 45, folder 12. In Burkholder's notes to Ideas, 135, Charles Ives's diary entry of June 5, 1914.

²³Charles Ives, Memos, 42-43.

²⁴Here, Ives programmatically describes memories and fantasies of a children's camp-meeting in Connecticut in the

Horatio Parker (1863-1919) was Ives's music instructor at Yale. Ives studied with Parker for three years. Parker's influence was a foil to Ives's eventual atypical-style since Parker was known as a "pedagogue and for composing typical, even highly derivative vocal works influenced by Brahms, Dvorak and Gounod."²⁵ Parker taught Ives about the "European tradition [of] symphonies and sonatas"²⁶ through study of harmony, history, counterpoint and fugue. Parker "objected to program music ... and emphasizes [sic] 'form and substance' as the foundation of music." He also rejected "philosophy, religion, jokes, definite ideas [and] sometimes even physical happenings."²⁷ It is interesting to observe that all of these items "objected to" were synthesized by Ives to suit his own aesthetic and compositional purposes--speaking with his own voice as opposed to that of "the three B's."

Outside of Parker's classes, Ives heard "ragtime at Poli's, a vaudeville theater in New Haven, [played by] piano player George Felsburg."²⁸ Ives also wrote "humorous pieces,

late-1800s . This program is identical to the setting for Putnam's Camp--a child's fantasy picnic with wondrous musical, natural, and religious fervor. Both programmes are attached in appendices 1 and 2.

²⁵New Grove Dictionary of American Music, 1st ed. s.v. "Parker, Horatio" by William Kearns.

²⁶Burkholder, Ideas, 61.

²⁷Ibid., 133-134. From an Episcopalian address that Parker delivered.

sentimental love ballads, and college songs."²⁹ John Griggs was the choirmaster at Center Church in New Haven, where Ives was organist. Griggs's belief in pure intonation³⁰ may have influenced Ives's unusual use of enharmonic interval notation (found in most of his scores). Griggs was also interested in "the literary aspects of music," had published articles which discuss "the dichotomy between content and manner in music"³¹ and introduced Ives to "a little" of Debussy's music.³²

Ives's use of quotation is famous and well-documented. About 150 examples are identified by Kirkpatrick.³³ These quotations have been classified as "modeled on an existing

²⁸Burkholder, Ideas, 64-66. Aside from this, not much is known about the piano player George Felsberg.

²⁹Ibid., 64-66.

³⁰John Griggs, "Possibilities of a Pure Toned Organ", Music (Chicago) 2, (September 1892): 483-490. Also see Ives, Memos, 254. For further information on Griggs see Burkholder, Ideas, 68-72.

³¹Burkholder, Ideas, 71, 135.

³²Even though Elliot Carter states: "And it is obvious to me...that Ives was very familiar with the music of Debussy. There are many...conceptions of music that came out of Debussy." (In an interview from Charles Ives, Charles Ives: The 100th Anniversary, Columbia Records, Record No. M4 32504.), actual references to Debussy are few. They include reference to the "natural heights" of La Mer in Charles Ives, Essays, 82, and a musical quotation of L'Après Midi d'un faun in song 17 of 118 Songs, by Ives. For a full list of quotations used by Ives see Clayton Henderson, The Charles Ives Tunebook (Michigan: Harmonie Park Press, 1990).

³³The New Grove Dictionary of Music and Musicians. (London: Macmillan, 1980), s.v. "Ives, Charles E.," by John Kirkpatrick.

work or structure, paraphrased tunes, cumulative settings (with development through motif expansion), strict quotation and a medley of quotes as a tour de force."³⁴ A good example of a cumulative setting leading to strict quotation is found in the Fourth Violin Sonata which is a paraphrase of "We Shall Gather At The River."

Most of the literary sources for Ives's music originate from the reading lists, dating from 1894-1898, of William Phelps, Ives's literature professor at Yale. Many of the texts Ives set were from the actual poems or prose studied under Phelps.³⁵ Harmony Ives was also an inveterate reader and poet; Autumn and Mists are two examples of her poetry that Ives set in 1907 and 1910. Ives's own writing of poetry and prose seems to flourish around 1907 (the year of Charles's marriage to Harmony). The impact of his political beliefs is shown by such songs as A New River (anti-pollution), The Anti-Abolitionist Riots, and An Election (critical of uninformed voters). Many of Ives's preferred texts have a definite, often cynical, message. Lindsay's controversial poem, dated 1914, "General William Booth Ascends to Heaven" is set by Ives through a parody of a Salvation Army March

³⁴Peter Burkholder, "Charles Ives: 'Quotation' and Emulation: Charles Ives's uses of his models," Music Quarterly 71 (1985): 1-26.

³⁵For Ives's reading list with Phelps, see Burkholder, Ideas, 74.

with General Booth (of the Salvation Army) still fervently proselytizing, even after death!

Ives could view music and life as an "idealistic and eclectic whole" and was inspired by the philosophies of Emerson and Thoreau³⁶ (through such writings as Emerson's Self-Reliance and Thoreau's Walden)³⁷ with which Ives was both familiar and sympathetic.

Charles Ives was able to blend influences of classical form and reason (Parker's approach), openness (to the musical and natural environments), and experimentation. These are the main facets of his unique stylistic synthesis.

Three Places in New England

There are problems in precisely locating Three Places in New England within Ives's output; difficulties arise because of the alternative titles, ordering of sections, and revisions. It is, however, a representative piece of Ives's mature style.

Three Places In New England was originally entitled the First Orchestral Set. Ives also considered other titles, including A New England Symphony, Orchestral Set No.1 , and

³⁶Burkholder, Ideas, 106-108.

³⁷Ralph Waldo Emerson, "Self-Reliance" in The Writings of Ralph Waldo Emerson (New York: Random House, 1950), 145-169; and Henry David Thoreau, Walden (Princeton, New Jersey: Princeton University Press, 1971).

Three New England Places. Since The Holidays Symphony (1909-1913) was alternatively titled Symphony IV, Three Places in New England could have been entitled Symphony V, which would have made the actual Symphony IV into Symphony VI!³⁸ The separate publication and performance of the components of the Holidays Symphony, which Ives encouraged, shows his willingness to subdivide or interchange these pieces from a larger collection. Ives had even considered switching the order of the outer two movements in Three Places in New England.³⁹ Another example of this interchangeability is Ives's proposed "patriotic set" with

I. Putnam's Camp, II. 2'nd Symp. finale, III. Decoration Day, IV. A War March ("THEY ARE THERE") (or 4'th of July could be 1st also St. Gaudens, and at end Thanksgiving).⁴⁰

A complete list of this orchestral genre that compares to Three Places In New England is given in table 1.1. The reader will find a great deal of similarity in the works listed here; similarity exists in their programmatic titles, common durations (of from four to ten minutes), scoring for

³⁸Charles Ives, Three Places in New England, ed. James Sinclair, Ives Society Critical Edition (Byrn Mawr, Pennsylvania: Mercury Music Corporation, 1974), vi.

³⁹Ibid., iv.

⁴⁰Ibid.; from a sketch for a letter to Serge Koussevitsky, dated 1943.

orchestra (with possibly interchangeable part-assignment),⁴¹ and a predominance of largo or slower tempos.

Table 1.1--Three Places In New England and comparable works

<u>Large Work</u>	<u>Pieces</u>	<u>Date</u>
<u>Three Places in New England</u>	(1) The 'St. Gaudens' in Boston Common (2) Putnam's Camp, Redding, Connecticut (3) from The Housatonic at Stockbridge	1911-12 1912 1908-14
<u>Holidays Symphony</u>	(1) Thanksgiving (2) Washington's Birthday (3) Decoration Day (4) The Fourth of July	1904 1909 1912 1911-13
<u>Robert Browning Overture</u>		1908-12
<u>Second Orchestral Set</u>	(1) An Elegy to our Forefathers (2) The Rockstrawn Hills (3) From Hanover Square	1909 1909 1915
<u>Third Symphony</u> (The Camp Meeting")	(1) Andante "Old Folks Gatherin" (2) Allegro "Children's Day" (3) Largo "Communion"	1904
<u>Fourth Symphony</u>	(1) Prelude: Maestoso (2) Allegretto (3) Andante Moderato (4) Largo	1910-11 1911-16 1909-11 1911-16

In this repertoire Ives uses many familiar American, and often patriotic, quotations, although perhaps, as Burkholder says,

Because of the tendency of programmatic ideas to color our evaluation of music, especially Ives's music, on its own terms, it is important to stress that Charles Ives's works do make sense as musical structures

⁴¹Ibid., vii. Ives's view of flexible part-assignment is shown in his conductor notes to Three Places In New England: "Page eighteen.-J-If the orchestra is large, it may be better to have more than two violins play the upper part (harmonic)."

alone, beyond any extra-musical meaning they may¹⁷
have.⁴²

As table 1.1 shows, in this pre-First World War period he finished some of his shorter works for orchestra. Very little new music was written and completed by Ives, after 1916, apart from revisions of earlier music and conceptions.

Ives's reworking of his music is confusing; themes from "Putnam's Camp, Redding, Connecticut," for example, were derived from Overture 1776 (1903) and Country Band March (1903). These pieces were to have been combined into an opera (Benedict Arnold--based on Lyman Brewster's play Major John Andre).⁴³ Some of these themes originating from Overture 1776 and Country Band March were later worked into sections of the "Allegretto" of Ives's Fourth Symphony as well as the Concord Sonata, revised circa 1915. The piece "from The Housatonic at Stockbridge" was also arranged for voice and piano.⁴⁴

Maynard Solomon and Philip Lambert raise questions of precise dating or "veracity" and musicological/aesthetic issues vis-a-vis Ives's creative process.⁴⁵ This

⁴²Burkholder, Evolution, 260.

⁴³The New Grove Dictionary of Music and Musicians. (London: Macmillan, 1980), s.v. "Ives, Charles E.," by John Kirkpatrick.

⁴⁴Charles Ives, "from The Housatonic at Stockbridge," in 114 Songs, (Bryn Mawr, Pennsylvania: Merion Music, 1935), 31-35.

⁴⁵See Maynard Solomon, "Charles Ives: Some Questions of Veracity," Journal of the American Musicological Society 40 (Fall 1987): 443-470. Solomon suggests that Ives backdated

Solomon/Lambert debate does not, however, affect that Ives amended Three Places In New England in response to Slonimsky's request for a piece to be performed by the Boston Chamber Orchestra.⁴⁶ Further, Carol Baron responds to issues of precise dating of Ives's music:

"Putnam's Camp" was composed during the first half of the second decade of this century ... many of the rhythmic innovations and the spikey dissonances [in] "Putnam's Camp" already existed in the earlier works, which we can now date in the first decade of this century.⁴⁷

The premiered version was again revised in 1934, prior to publication:

at this stage Ives made some last-minute provisions for the use of extra winds, thereby cultivating the confusion over whether the score was for chamber or large orchestra.⁴⁸

The Mercury Edition of 1935 (for chamber orchestra) is the definitive Ives version, rather than the Sinclair Edition

and recomposed most of his music, and denied being influenced by anyone other than his father in order to appear as an isolated New England genius. See also Philip Lambert, "reply" in Journal of the American Musicological Society 62 (Spring 1989): 204-209; and Maynard Solomon "counter-reply," in Journal of the American Musicological Society 62 (Spring 1989): 209-218.

⁴⁶Sinclair ed., Three Places In New England, v: "Slonimsky's Boston Chamber Orchestra [consisted of]: single winds (with 2 horns and 2 trumpets), 1 percussion, 1 piano, 7 violins, 2 violas, 2 celli, and 1 bass. [The] piano part . . . covered missing lines . . . In doing so Ives . . . added new musical material for the piano."

⁴⁷Carol Baron, "Dating Charles Ives's Music: Facts and Fictions," Perspectives of New Music 28 (Winter 1990): 49.

⁴⁸Charles Ives, Three Places In New England (Boston: Mercury Music Corporation, 1935).

(for full orchestra). This thesis refers throughout to the 1935 Mercury edition.

Three Places In New England is conceived as a retrospective programmatic setting of New England life. Each piece is temporally set, respectively, in the 18th, 19th, and 20th centuries. Ives's music here is programmatic and not wildly experimental. Further, he freely and convincingly combines different images simultaneously with his views of the American experience in New England.

CHAPTER 2

PARTITIONING CRITERIA FOR THREE PLACES IN NEW ENGLAND

A Theory of Partitioning

In the following discussion I present some methods of determining formal divisions--partitions--in Three Places In New England. These partitioning criteria will then be applied to "from The Housatonic at Stockbridge" in chapter 3. Three Places In New England ranges from straightforward stylistic--and formal--emulations of other pieces (as in the Country Band March sections of "Putnam's Camp, Redding, Connecticut")⁴⁹ to asymmetrical or gradually changing sections such as the ritardando/decrescendo section in "Putnam's Camp, Redding, Connecticut," (F+4) to (G).⁵⁰ Since Ives's eclectic

⁴⁹The A- and B-themes (as shown in example 2.2) of "Putnam's Camp, Redding, Connecticut" are direct quotations from Ives's own Country Band March. (B) to (C) and (E) to (E+1) are derived from Marching Through Georgia, according to Stein, Musical Language, 109-112. The form of Marching Through Georgia is not difficult to determine; it is, in measures, A (4+4), B (4+4) with the first phrase in each period ending on V7, and the second phrase on I.

⁵⁰In this transitional section, the tempo, loudness, and number of sounding parts (density-number) all decrease continuously over fourteen measures. In order to identify measure locations, the indication "letter F+4" (the fifth measure after letter F) to "letter G" will be denoted by (F+4) to (G). The area about "letter F" (mm.44-47) thus reads, in order: (F-2), (F-1), (F), (F+1).

approach often combines several compositional styles, a variety of analytic approaches to form is required.

Ives's personal style of composition and formal organization complicates the direct application of traditional formal grouping based on phrase, period, and larger forms (such as sonata design); for example, in the next chapter the formal plan for "the 'St. Gaudens' in Boston Common" (figure 3.3) is based on phrases. A comprehensive interpretation of the form requires additional information for the many sections in which Ives's formal schemes are not readily apparent.

Partitioning-criteria or form-defining parameters which apply to Ives's compositions (and to other polyharmonic 20th-century works) are summarized in table 2.1 below. My premise is that a greater disruption (by a substantial change in a musical parameter) of the music creates more noticeable or important partitions compared with lesser disruptions, which create less noticeable or lower-level partitions. These partition-defining parameters are arranged in a descending hierarchical order of effect, a lower number having more weight. For example, a change in category (1) (a long tutti rest), creates a more obvious partition than does a change in category (5) (a subtle shift in timbral assignment).

The first step towards partitioning is to determine phrases (with extensions or elisions), note double bars, and tempo indications; the results of this stage are reported in chapter 3. The purpose of the following apparatus, though,

is to verify the partitions identified in the study of phrase structure; this is accomplished by a comprehensive and systematic examination of changes in surface details. Table 2.1 lists parameters which cause partitions.

Table 2.1--Partitioning parameters

Partitioning Parameter:
1 Silence
2 Repetition
3 Rhythm
(a) meter
(b) tempo
(c) micropulse
4 Pattern completion
(a) harmonic cadence
(b) melodic completion
5 Orchestral details
(a) loudness
(b) density
(c) pitch-content
(d) instrumentation
(e) tessitura
(f) texture
6 Tonality
7 Scalar resources
8 Number of strata

Partitioning Parameters

Silence

In most cases silence serves to separate and articulate, with longer silences yielding a greater sense of partition. Silence can be an obvious delineator of sections. A long duration of silence is a conclusive divider (unless the context works against this--if many pauses are usual); while a short duration has a less drastic effect (the pause could be a "breath" or an interruption of a larger-scale line). An example of silence as a form-defining parameter is found at (B-1) of "The 'St. Gaudens' in Boston Common"--see example 2.1. In this excerpt there is a cessation of sound for almost two beats, between the c#³ at (B-1) and the d² entry at (B).

Example 2.1--"The 'St. Gaudens' in Boston Common" (B)

The image shows a musical score for a section of "The 'St. Gaudens' in Boston Common". The score is written for a full orchestra, including Flute (Fl.), Clarinet (Cl.), Piano (Piano), Violin I (Vl. I), Violin II (Vl. II), Viola, Cello (Cello), and Bass (Bass). The score is divided into measures by vertical bar lines. A circled 'B' is placed above the third measure, indicating a specific point of interest. An arrow points upwards from the bottom center of the page towards the circled 'B'. The score includes various musical notations such as notes, rests, and dynamic markings like 'pp' (pianissimo) and 'f' (forte). There are also some handwritten annotations in the score, such as "More notes than scored?" and "pp".

Repetition

Repetition and contrast (new material) are important contributors to segmentation. Repetitions of large scale, for example, such as the reprise of section A following a contrasting section B, engender ternary forms, (A,B,A) with partitions between A/B and B/A. This is the form of "Putnam's Camp, Redding, Connecticut." Its main themes from the first A-section⁵¹ are shown in example 2.2.; a formal plan is given in figure 3.4. The themes from the first A-section are interrupted by different themes and several quotations of martial (and other) tunes in the B-section; after which the C-theme from the first A-section returns at (M). This repetition at (M) signals a partition.

Repetition of motives is common in Ives's music. The first A-section in "Putnam's Camp, Redding, Connecticut" begins with themes A,A1,A2,A,B,C. A change to new material following several repetitions can also segment the piece--such as the B and C in A,A1,A2,A,B,C in example 2.2, below.⁵²

⁵¹"Sections" are used here to mean the largest formal units into which an entire piece may be divided. For example, there are three sections in "Putnam's Camp, Redding, Connecticut." They are respectively 63, 50, and 50 measures long. See figure 3.5 for an overview of the form in "Putnam's Camp, Redding, Connecticut."

⁵²The change from "A" to "B" is subtle because the themes are similar.

Example 2.2--Themes (incipits) in the A-Section of "Putnam's Camp, Redding, Connecticut"

2.2A

A-theme

Stratum!

Stratum!

V

2.2D

(D) - A theme

2.2B

B-theme

(D+A)

2.2E

B-theme

2.2C

(C-G) A²-theme

2.2F

C-theme



Another kind of segmentation is found between exact repetition and slight alteration (A/A1 where A1 is a modified A). Here, the difference between A and A' is subtle and acts as a low-level partition of phrases, while the A,A1,A2,A/B/C divisions are more dramatic and therefore constitute a higher-level division.

Rhythm

Meter, tempo, or micropulse⁵³ may exhibit changes sufficient to create partitions. A change of meter that is sustained for several bars--for example, 7/8 following 3/4--will probably cause a sectional break. Significant tempo changes (largo to allegro) tend to divide sections (although slight increases or decreases of tempo--for example, the indication meno--have less effect). The interruption of a passage dominated by an eighth-note micropulse by, for example, a half-note melody may also create a partition.

Example 2.3, (H-2) to (H+2) from "Putnam's Camp, Redding, Connecticut," contains changes in tempo, meter, and micropulse. These rhythmic parameters all contribute to the partition at the downbeat at (H). The tempo change from Andante animato to Poco meno mosso is not drastic but has a

⁵³Micropulse is the lowest common rhythmic unit of the predominant (most audible) rhythms; such as eighth-notes at (B) to (B+1) of example 2.2 and 6:4-quarter-notes at (C+6) to (C+7).

noticeable broadening effect. The change of meter from (H) to (H+1) is not linear but is superimposed. This is because the bassoon, drum, and piano act as a second ensemble and play eight beats in the space of six (at a ratio of 8:6, or 4:3--one-third faster) relative to the "main" ensemble.⁵⁴ The change of micropulse is from half-note at (H-2), to quarter-note at (H-1), to eighth-note at (H) to (H+2). In example 2.3, there are other rhythmic strata: the sixteenth-notes at (H-2) to (H-1) and the one-third faster quarter-notes at (H+1) to (H+2). These, however are not as loud or as dense as the predominant rhythms of the strings.

Pattern completion

Two types of surface-level pattern completion are common: harmonic cadences and melodic completions. "Harmonic cadence" refers to conventional closing formulas such as V-to-I. "Melodic completion" is a pattern resolution where a familiar quotation or motive is concluded. These melodic-completions signal phrase-endings and musical divisions. There is a harmonic I-V before theme A at (B) from "Putnam's Camp, Redding, Connecticut," as in example 2.2A. The V7-I cadence into (B) marks the beginning of a new thematic presentation. The melodic completion of the first A-theme (shown in example

⁵⁴Note Ives's indication here, for bassoon, drum, and piano, "as a distant drum beat." This suggests that the metrical difference is caused by two different ensembles.

2.2B) is from the eb^2 , in violin I, at (C-1) to the d^2 at (C) (this is "over" a V7-I, in B^b major). The completion at (C) is also the beginning of the next A-theme.

Example 2.3--"Putnam's Camp, Redding, Connecticut"
(H-2 to H+2)

65 *Andante animato (about 60-65)* $\text{\textcircled{B}}$ *Poco meno mosso (about 50-55)* 33

The musical score is arranged in a standard orchestral format. The instruments listed on the left are: Fl. (Flute), Ob. (Oboe), Cl. (Clarinet), Bas. (Bassoon), Hn. (Horn), Trpt. (Trumpet), Tromph. Tuba (Trombone/Tuba), Sn. Dr. / Base Dr. (Snare/Bass Drum), Piano, Vl. I (Violin I), Vl. II (Violin II), Viola, Cello, and Base (Bass). The score is divided into two main sections. The first section, starting at measure 65, is marked *Andante animato (about 60-65)*. The second section, starting at measure 100, is marked *Poco meno mosso (about 50-55)* and includes the instruction *(very slightly slower)*. A *Solo* marking is present above the Oboe staff in the second section. The Piano part includes the instruction *ppp (as a distant drum beat)*. The Violin I part includes the instruction *2nd Viol. ppp (as a distant drum beat)*. The score contains various musical notations such as notes, rests, dynamics (pp, ppp, mod.), and articulation marks.

Orchestration and texture

Orchestration and texture may also exhibit changes which cause formal partitions. Examples of different changes for each of the orchestral parameters are given as follows.

Loudness. The change in loudness in example 2.2F, at (E), causes the partition of (E); Ives employs a shift from *ff* to *p/pp*. This loudness change is sudden, rather than gradual.

Example 2.4--"Putnam's Camp, Redding, Connecticut"
(G-6 to G)

The musical score for "Putnam's Camp, Redding, Connecticut" (G-6 to G) is presented in a multi-staff format. The instruments listed on the left are: Fl. (Flute), Ob. (Oboe), Cl. (Clarinet), Bas'n (Bassoon), Ho (Horn), Trpt (Trumpet), Tromb. / Tuba (Trombone/Tuba), Sn. Dr. / Bass Dr. (Snare Drum/Bass Drum), Piano, VI.I (Violin I), VI.II (Violin II), Viola, Cello, and Bass. The score begins with a dynamic marking of *fff* (fortissimo) and a tempo marking of *Quasi largo*. At measure 6, there is a significant dynamic shift to *p* (piano) and *pp* (pianissimo), which is noted as the cause of a formal partition. The score includes various musical notations such as notes, rests, and dynamic markings like *ritard.* (ritardando) and *Quasi largo*. The piece concludes with a final dynamic marking of *fff*.

Density. Density is the total number of separately sounding parts. Pitch-class content is the number of different pitch-classes. In example 2.3, the density change from the vertical "slices" (H-1, b. 3) to (H, b. 1) is from 19 notes to 10. At (H-1, b. 3) there are 10 pitch-classes versus 5 at (H, b. 1). Thus, from (H-1, b. 3) to (H, b. 1), the density drops by 8 while the pitch-class content drops by 5.

Instrumentation. Different instrumental assignments articulate formal divisions between sections of "Putnam's Camp, Redding, Connecticut." On the one hand, Ives usually scores themes in section A for strings, accompanied by winds (as in example 2.2); on the other, themes in section B are usually assigned to winds and accompanied by strings (as in example 2.3).

Tessitura, texture. Low tessitura, thin texture, as well as decreased density and a decrease in loudness occur in example 2.4--from (G-6) to (G). The abrupt changes, at (G), in these four parameters combine to create a partition. Example 2.1 illustrates changes in texture type: from homophonic at (B-3) to (B-1), to contrapuntal at (B) to (B+2).

Tonality

Ives's music includes modulations to closely-related and distant keys. In addition, strata whose distinguishing features include opposing tonal centers are occasionally in evidence; this feature is discussed in chapter 4 (figures 4.6

and 4.7). Modulations to closely related keys may be found in example 2.5 from "Putnam's Camp, Redding, Connecticut": the A-theme in B^b major, beginning at (C), modulates to its relative minor--G minor at (C+3) to (C+4). A distant modulation occurs from C-theme in C major, at (N), to the final A-theme, in A^b major, at (N) to (N+5).

Example 2.5 Close and Distant Modulations in "Putnam's Camp, Redding, Connecticut"

(C)

B^b major

(C+3)

V → I
G minor

(N)

C major

(N)

A^b major

Scale resources

Changes in pitch resources of themes or motives will also contribute to partitioning. Many of the pitch resources used in Three Places In New England are diatonic, as are the motives from "The 'St. Gaudens' in Boston Common" (see example 2.1). One collection, at (B-3) to (B-2) in the first violin, contains part of the C-diatonic scale (A-G-E-G), over C/a. Part of this motive is then transposed up a fifth, at (B), to G-diatonic (D-B-D), over D#.

Ives utilizes diatonic passages in the A-themes of "Putnam's Camp, Redding, Connecticut" (example 2.2A), and changes the linear content to chordal outlines (as in the C-theme, example 2.2F) at a partition. Possible linear scale-types include (1) a predominantly diatonic melody or (2) a dense, highly chromatic melody.

Number of strata

A change in the number of strata also causes a partition: in example 2.2A, at (B-1) to (B), the number of strata changes from one to two. At (B-1) a stratum is the vertical segment--the V7 collection on the beat 4 of (B-1) or (B-1, b. 4); at (B) the strata are encircled in example 2.2A as (1) the melody in violins and viola I and (2) the eighth-note accompaniment. In chapter 4 strata determinants are discussed as well as an analysis of rhythmic and harmonic

strata located at the three main partitions in "from The Housatonic at Stockbridge."

Proportional Schemes

Once the locations and relative weights of partitions have been discovered, the formal characteristics of Three Places In New England may be observed. These observations are of two types: (1) proportions and patterns of symmetry, asymmetry, and arithmetic series; and (2) dynamic tendencies. Figure 2.1 shows some of the proportions in the B-section of "Putnam's Camp, Redding, Connecticut."

Figure 2.1--Phrase-Form in the B-Section of "Putnam's Camp, Redding, Connecticut"

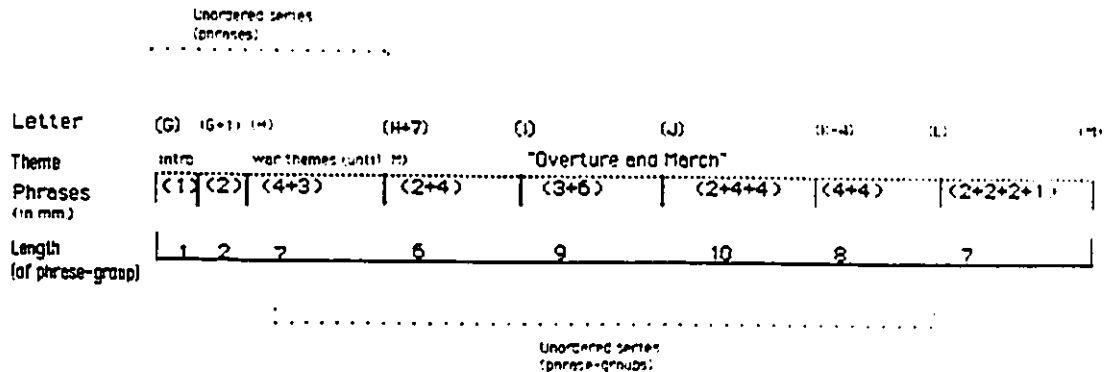

Facets of proportionality in figure 2.1 that may be observed are at the phrase level--the use of 2 and 4 mm. units with two elisions to generate 3 m. units; and at the phrase-group level--after the introduction of 1+2 measures, the use of only one 8 m. section and three elided (6 mm., 7 mm., and 7 mm.) and two extended (9 mm. and 10 mm.) sections. One might expect 4 or 8 mm. to be the "norm" for the length of Ives's formal units, since the themes from which he draws are themselves 4 and 8 mm. long. For both phrase and phrase-group levels, there are unordered series of measure-lengths. These are shown and labeled in figure 2.1. The first four phrases form an unordered series of 1, 2, 4, and 3 mm.; the phrase-groups form an unordered series of 7, 6, 9, 10, and 8 mm.

Kinetic Aspects of Form

There are instances in Three Places In New England where Ives exhibits a tendency to increase or decrease musical events over time, within one or more parameters. One such case is in example 2.4 at (G-6) to (G)--there is a tendency here to decrease (or lower) the tempo, micropulse, loudness, density, pitch-content, instrumentation, and tessitura. "Kinetic" form is thus a tendency towards change, viewed over time. Significant factors concerning a kinetic change are the type of continuous change(s) (+ or -), the boundaries of change(s), and the effects of these trends.

Kinetic form means

. . . formal units . . . defined by the boundaries of tendencies of increase or decrease in any musical parameter . . . [which] may be perceived as a sense of motion towards or receding from these boundaries.⁵⁵

Further, according to Wallace Berry,

The grouping of tendency-affiliated events crossing distinctions between elements is another mode of unit delineation . . . to a given progressive or recessive tendency . . . an important area of grouping in this special sense.⁵⁶

Ives's composition, Three Places In New England, shows several tendencies to accelerate. Parameters such as loudness, density, tempo, and micropulse can be seen and heard to grow throughout sections of each piece on first listening. Example 2.4 illustrates another sort of kineticism--a deceleration. This decrease in "Putnam's Camp, Redding, Connecticut," is from 14 mm. earlier, at (F+4) towards the fermata at [G]. The reduction in intensity is a medium-scale feature that combines decreases in several parameters and follows Ives's program: "the tunes of the band and the songs of the children grow fainter and fainter . . ."⁵⁷

⁵⁵Richard Parks, The Music of Claude Debussy (New Haven and London: Yale University Press, 1989), 233-247.

⁵⁶Wallace Berry, Structural Functions in Music (New York: Dover Publications, 1987), 320.

⁵⁷Ives, Three Places, 20.

CHAPTER 3

FORM IN THREE PLACES IN NEW ENGLAND: AN OVERVIEW

In this chapter, I will describe aspects of the form of Three Places In New England. To do this, I will begin by discussing the entire work and common formal characteristics among pieces; I will then examine the phrase structure of the individual pieces. The issue of performance-order has been discussed in chapter 1; all performances and recordings that I know of follow the order of the Mercury edition. The durations and key relationships of this version of Three Places In New England are shown in figure 3.1. The combined durations of "Putnam's Camp, Redding, Connecticut" and "from The Housatonic at Stockbridge" are approximately the same as the duration of "The 'St. Gaudens' in Boston Common." Also, there is a progression towards shorter durations from piece to piece.

Figure 3.1.--Overall Form in Three Places In New England

Piece	1	2	3
Title	St. Gaudens	Putnam's Camp	Housatonic
Duration	8:36	5:58	3:47
(Michael Thomas conductor)			
Duration	9:30	5:45	4:01
(James Sinclair conductor)			
Tonal Areas (first, last)	C/a, C [#]	Bb, A [#]	C [#] , F [#]

The end of each piece is connected to the beginning of the next piece by keys that lie three semitones apart: C# to B^b and A# to C#--a macrocosm of the predominant interval in "The 'St. Gaudens' in Boston Common," which is the minor third.⁵⁸ At a large-scale analytic level, the final F#-tonality is the "most-distant" key relative to the initial C-tonality.⁵⁹

Kinetic Increases

Each of the pieces of Three Places in New England shares elements of form and design, as illustrated graphically in figure 3.2. Common features include a kinetic tendency towards increase in the realms of tempo, loudness, and density. One of the most outstanding shared features is the gradual increase in loudness in each piece, very soft (*ppp*) to very loud (*fff*).

The gradual crescendos in "The 'St. Gaudens' in Boston Common" are in two parts: for most of the piece (63 of 83 measures) the paradigm is *ppp* to *fff*; this is followed by a crescendo from *p* to *pp*.

⁵⁸Stein, Musical Language, 43: "The very opening bar of "[The] 'St. Gaudens' [in Boston Common]" introduces the main structural interval of the entire movement. A minor third--F to D and back to F (as stated in the flute and piano)--serves this purpose."

⁵⁹The final V-I to F#7 (versus F#) is an intriguing "conclusion" to Ives's interpretation of this poem--is Ives portraying an unresolved journey from the "adventurous sea"?

In "Putnam's Camp, Redding, Connecticut," the increase of loudness proceeds in waves: (1) *p* to *mf* at letter (F+1), (2) *ppp* to *f* at (I+4), (3) *p* to *fff* at (M), and finally, (4) *pp* to *ffff* at the end. Even though there is a 12 mm. diminuendo after (F+2), there are a total of 92 mm. containing long crescendos in this piece; these "waves" are progressively more dramatic in their tendencies to dynamically increase.

Figure 3.2.--Common formal elements in Three Places In New England

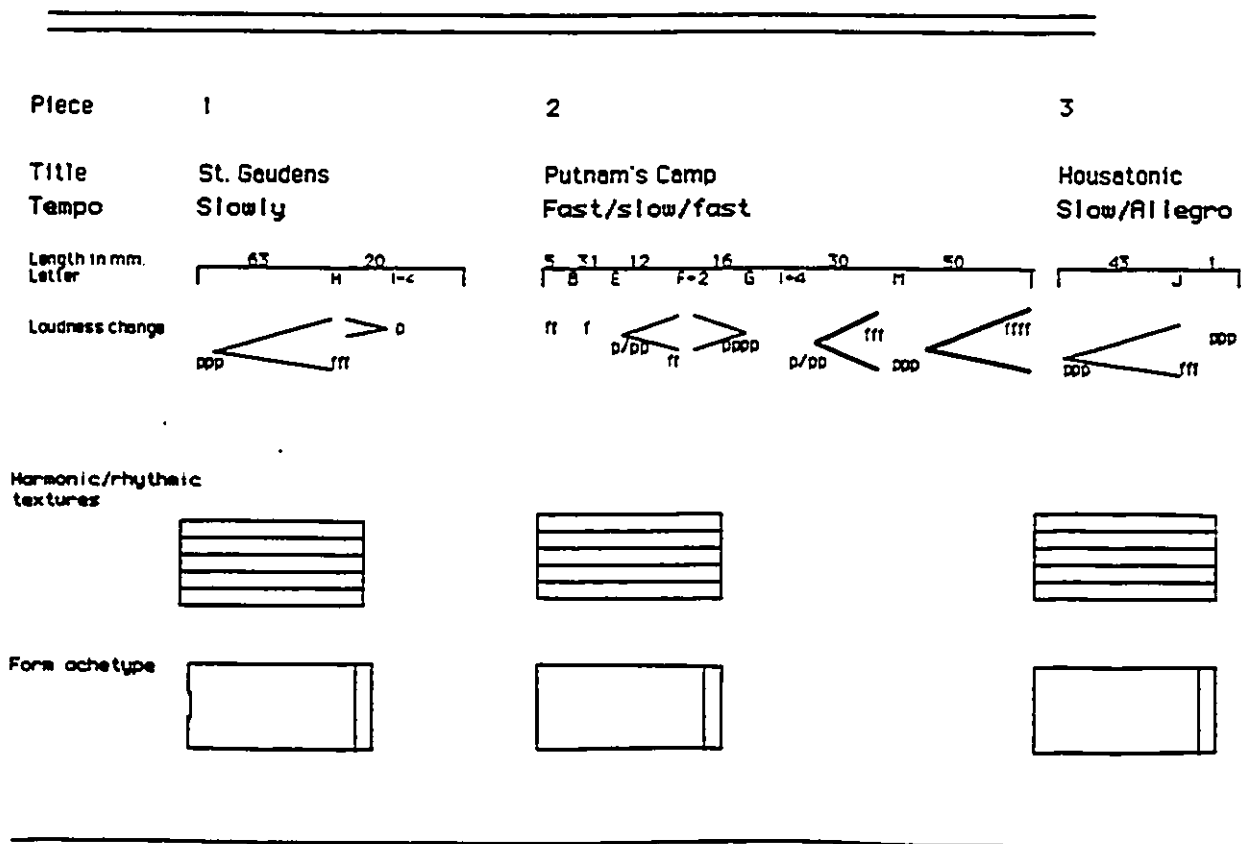

Ives complements these increases in loudness with an additive growth in density-number and density-compression⁶⁰ as well as growth in the number of simultaneous, conflicting subdivisions. Example 3.1 shows the highest loudness-locations with their progressively increasing pc densities--for each piece of Three Places In New England.

In "Putnam's Camp, Redding, Connecticut," an overall slow tempo predominates, except for the dream-like, and often rhythmically out-of-phase, "Quick Step Time," (the A-themes), but the tempo tends to accelerate in each section of the piece. Indistinct orchestral textures derived from layering⁶¹ (superimposition) of more than one harmony and/or rhythm, coupled with much use of a low tessitura, bind these musical "places" together. The common elements in figure 3.2 range across widely separated extremes in each piece; this is illustrated by different levels of loudness listed above (in

⁶⁰I use the terms "density-number" and "density-compression" in the same sense as Berry; for more information on density versus texture see Wallace Berry, Structural Functions, 209-213; here Berry states:

Density as the number of sounding components is the *density-number*; density as the ratio of the number of sounding components to a given total space is the *density-compression* . . . the proximities by which components are separated in vertical alignment (the degree of compression) constitute an aspect of density . . . the issue of dissonance has to be regarded as a related, conditioning factor.

⁶¹Burkholder, Evolution, 600. Harmonic layers in "from The Housatonic at Stockbridge" are described as a "background [of] harmonic mud, in a clear tonal context."

"Putnam's Camp, Redding, Connecticut") and by the graphs of rhythmic strata (in "from The Housatonic at Stockbridge") that follow in chapter 4.

Another similarity shared by the three pieces is their orchestration, which is full yet transparent, as there are many soloistic lines (separate or combined) set in various layers of counterpoint. The ensemble features the strings in each movement and the piano serves to bind and accentuate rhythmical activity. A final formal commonality is extra--"tacked-on"--endings which amplify the programmatic retrospective, as in awakening from a dream (Ives's program in "Putnam's Camp, Redding, Connecticut").⁶² These end-points occur in the final one or two measure(s) of each piece.

Codas ("end points") are located, in "The 'St. Gaudens' in Boston Common" at (J+7)--strings and piano, in "Putnam's Camp, Redding, Connecticut" at (U+2)--trumpet, and in the "from The Housatonic at Stockbridge" at (J+1) to (J+2)--strings. These are important formal locations as they serve as the final statements, which leave the last-heard impression of each "place."

⁶²The extra endings are in the program: "In the silence of a strange and Sounding afterglow" ("The 'St. Gaudens' in Boston Common"), "The little boy awakes, he hears the children's songs and runs down past the monument to 'listen to the band' and join in the games and dances." ("Putnam's Camp, Redding, Connecticut"). In "from The Housatonic at Stockbridge," Ives recalls "distant singing from the church across the [Housatonic] river" [on] 28 June 1908 (from Memos, 87). The coda recapitulates the hymn Ives is likely to have heard.

Example 3.1.--High loudness locations with pc densities in Three Places In New England

"The 'St. Gaudens' in Boston Common" (H, b. 1)

"Putnam's Camp, Redding, Connecticut" (U+2, b. 2)

"from The Housatonic at Stockbridge" (J, b. 1)

Musical score for "The 'St. Gaudens' in Boston Common" (H, b. 1). The score includes staves for Flute (Fl.), Oboe (Ob.), Clarinet (Cl.), Bassoon (Bsn.), Horn (Ho.), Trumpet (Tpt.), Trombone (Tromb.), Tuba, Tympani (Timp), Drums, Piano (Piano), Violin I (VI.I), Violin II (VI.II), Viola, Cello, and Bass.

Musical score for "Putnam's Camp, Redding, Connecticut" (U+2, b. 2). The score includes staves for Flute (Fl.), Oboe (Ob.), Clarinet (Cl.), Bassoon (Bsn.), Horn (Ho.), Trumpet (Tpt.), Trombone (Tromb.), Tuba, Sn. Dr. (Sn. Dr.), Bass Dr. (Bass Dr.), Piano (Piano), Violin I (VI.I), Violin II (VI.II), Viola, Cello, and Bass.

Musical score for "from The Housatonic at Stockbridge" (J, b. 1). The score includes staves for Flute (Fl.), Oboe (Ob.), Clarinet (Cl.), Bassoon (Bsn.), Horn (Ho.), Trumpet (Tpt.), Trombone (Tromb.), Tuba, Tympani (Timp), Piano (Piano), Violin I (I), Violin II (II), Violin III (III), Violin IV (IV), Violin (Violino), Cello, and Bass & Org. Ped. (Bass & Org. Ped.).

pc densities:

Handwritten musical notation for pc densities, showing a treble clef staff with notes and dynamic markings. Includes the notation $f/f/f$ and a circled number 5.

Handwritten musical notation for pc densities, showing a treble clef staff with notes and dynamic markings. Includes the notation $f/f/f$ and a circled number 8.

Handwritten musical notation for pc densities, showing a treble clef staff with notes and dynamic markings. Includes the notation $f/f/f$ and a circled number 12.

Phrases and Form

Now we will examine the phrase structure and programmatic aspects of form. Since Three Places in New England is permeated with quotations, and motives developed from quotations, it follows that the form may be understood by analyzing the arrangement and patterns of phrases quoted. Phrases are, in fact, the predominant type of strata in this music. Often, Ives's quotations themselves form strata (the unifying characteristic that binds the pitch-elements together being the familiar melody or fragment). The melodic stratum is separate from its accompaniments because of Ives's use of contrasting strata with different characteristics of timbre, register, pitch, rhythmic pattern, and also because we can recognize the structure or melodic motives in many of the phrases Ives uses. Their melodic motives are easily recognized and understood and thus set apart from the less-comprehensible strata that often accompany them. Nicolas Slonimsky's reaction to the score of Three Places in New England, upon seeing it prior to its premiere, expresses this dichotomy between vertical (polyrhythmic and polyharmonic) and linear (melodic and quotation) organization:

The score possessed elements that seemed to be mutually incompatible and even incongruous: a freely flowing melody derived from American folk-songs, set in harmonies that were dense and highly dissonant, but soon resolving into clearances of serene, cerulean beauty in triadic formations that created a spiritual catharsis. In contrast there were rhythmic patterns of extreme complexity; . . . The polytonalities and

polyrhythms in the Ives score seemed incoherent when examined vertically, but simple and logical when viewed horizontally.⁶³

This "simple and logical" melodic/horizontal plan is examined in figures 3.3, 3.4, and 3.5 below.

Musical quotation is common to most of Ives's music. In Three Places in New England, "Putnam's Camp, Redding, Connecticut" and "The 'St. Gaudens' in Boston Common" both include multiple quotations to create what Burkholder calls a "collage," while "from The Housatonic at Stockbridge" exemplifies paraphrase and the development of a single theme.⁶⁴

Phrase Structure in
"The 'St. Gaudens' in Boston Common"

The phrases in the "The 'St. Gaudens' in Boston Common" follow its program. This program is described in the preface to the score in a poem by Ives.⁶⁵ The poem and the music are inspired by the image captured by St. Gaudens--a sculpture

⁶³Nicolas Slonimsky, Perfect Pitch, (Oxford, New York: Oxford University Press, 1988), 119. Slonimsky's premiere of Three Places in New England occurred "at the Town Hall in New York on 10 January 1931"; *Ibid.*, 119-120.

⁶⁴Burkholder, Evolution, 373-380. For a list of some of the music quoted in this or any Ives piece, see Clayton Henderson, Tunebook, for the locations, and original forms of most of the known quotations.

⁶⁵This preface is by Ives, according to John Kirkpatrick, A Temporary Mimeographed Catalogue of the Music Manuscripts and Related Materials of Charles Edward Ives 1874-1954 (New Haven: Library of the Yale School of Music, 1960 [reprint 1973]), 14. It is reproduced in appendix 1.

depicting "Col. Shaw and his Colored Regiment" on the march (in the American Civil War). In the poem, Colonel Shaw's Regiment is

Moving, -marching-Faces of souls! . . . images of a
Divine Law . . . [wherefrom] . . . Rises the drum-beat
of the common-heart . . . In the silence of a strange
and Sounding afterglow⁶⁶

This poem is emotionally charged, amplified and elaborated by the musical phrase-choices in the "The 'St. Gaudens' in Boston Common."

There are two types of themes used in this piece. The first thematic-group is a collection of four quoted and paraphrased themes (labeled "A") which Ives reworks and extends (shown in example 3.2). These themes occur in, and help to define, the A-sections. The second thematic-group is a much larger collection of other (non-A) themes, and Ives's development of them. The "non-A" themes are in the B-section.

Four quoted tunes that make up the A-thematic group are Old Black Joe, Marching Through Georgia, The Battle Cry of Freedom, and Jesus Loves Me.⁶⁷ Ives chooses to emphasize melodies from the choruses of the above tunes and synthesizes them to form his own melodies. For example, Ives's A-theme at letter (A-8) to (A-6) incorporates all four of the above sources as illustrated in example 3.2.

⁶⁶As noted earlier, the coda of the "The 'St. Gaudens' in Boston Common" (J+7) may refer, musically, to the "strange and sounding afterglow."

⁶⁷Stein, Language, 43-52; Kirkpatrick, Catalogue, 14.

Example 3.2.--Thematic sources of A-themes in "The
'St. Gaudens' in Boston Common"

Old Black Joe
(chorus)

Marching Through
Georgia
(chorus)

Battle Cry of
Freedom
(chorus)

Jesus Loves Me
(chorus)

"The 'St. Gaudens'
in Boston Common"
(A-8 to A-6)

In example 3.2, the themes are transposed to the key of C for the sake of clarity. Harmonically, these melodies all incorporate a pentatonic fragment, E-G-A-C.⁶⁸ Ives does not add additional pitches to this in the A-themes although he does often transpose the fragment. Scale-degree 4 is introduced, however, at (I-4) to (I+2), where Ives quotes a longer passage from The Battle Cry of Freedom. The alteration of the B-flat, at (I-4) to (I-3), to B-natural in the flute at (I-2) (the "lydian" sharp-fourth of F major) is a noticeable

⁶⁸This pentatonic fragment of scale-degrees (1,3,5,6) is from the anhemitonic pentatonic scale

change of the diatonic mode from F major to C or G major. Other melodic modulations include E^b major, E minor, and F[#] minor, at (I-2) to (I+1).

For the B-section, and B-themes (see figure 3.3), Ives presents a ragtime-influenced medley of paraphrased quotations including Yankee Doodle, Oh Suzanna, and a figure that resembles bugle calls such as Reveille. At (F) to (F+3) Ives merges Yankee Doodle/Oh Suzanna/Yankee Doodle. This run-on collection of quotations can be viewed as a musical-political metaphor; the implied "text" here might read: "He [Yankee Doodle] stuck a feather in his hat . . . for I'm off to Alabam[a] . . . he stuck a feather . . ." Thus, the "Yankee" is literally placed in Alabama, just as Col. Shaw's Colored Regiment was, in the Civil War. A similar musical metaphor occurs in the A-section (as in example 3.2)--where Ives joins together material from Old Black Joe and the Battle Cry of Freedom.

The formal plan of "The 'St. Gaudens' in Boston Common" is a microcosm of Three Places in New England. In section B of the "The 'St. Gaudens' in Boston Common" the tempo is faster than the outer section-A's and in a marcato brass-band style; this is akin to "Putnam's Camp, Redding, Connecticut" which is faster and more marcato than the outer-pieces of Three Places in New England.

Figure 3.3.--Phrase-form in "The 'St. Gaudens' in Boston Common"

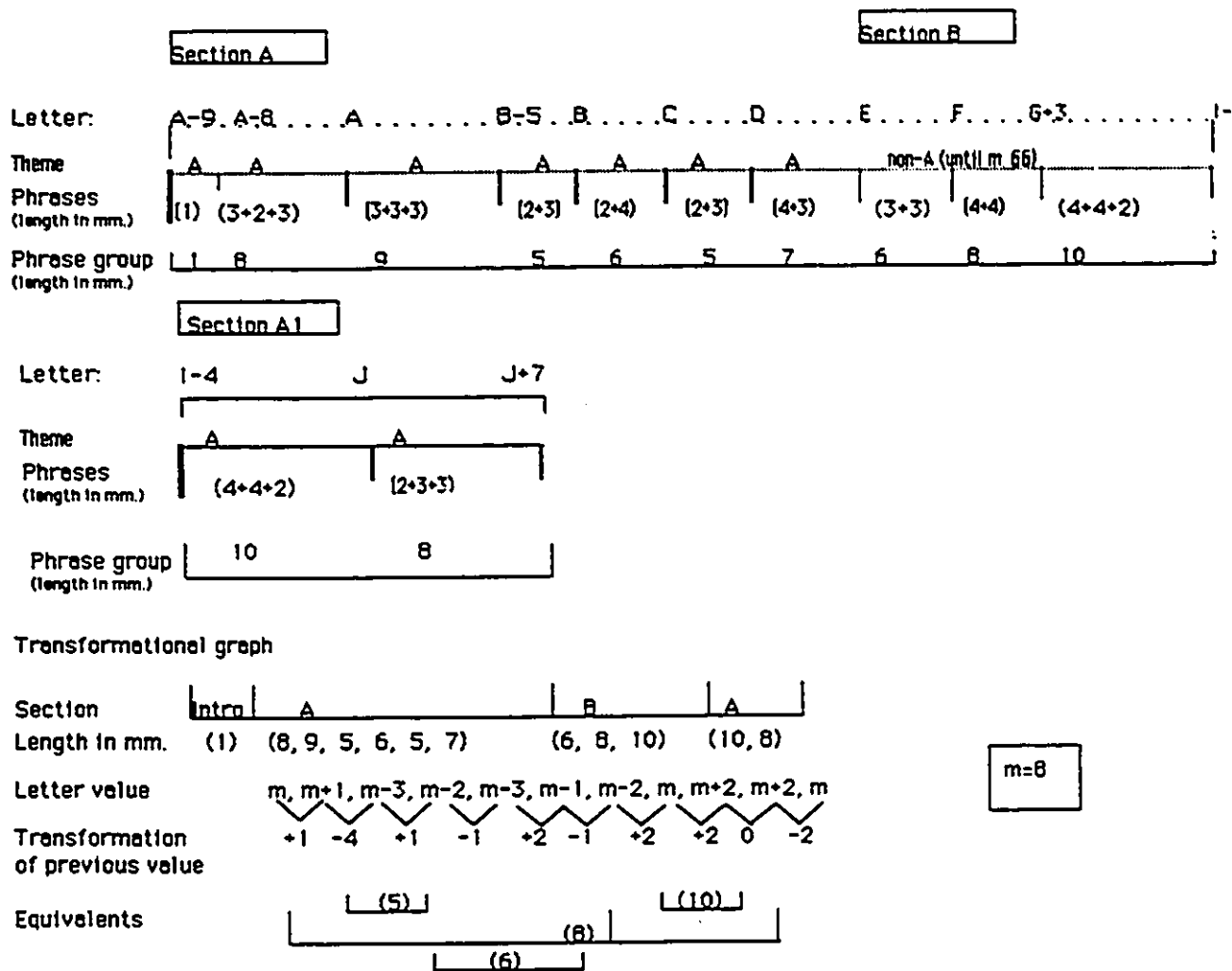

Figure 3.3 summarizes the phrase structure in the "The 'St. Gaudens' in Boston Common," as well as durations and

proportions. With the exception of (A-9), which is introductory and prolonged by a fermata, each of the phrases in the "The 'St. Gaudens' in Boston Common" is of 2, 3, or 4 measures in length. Ives tends to end a phrase-group (or thematic statement) with a three-measure phrase--this occurs in 7 of 11 phrase-groups. Proportional patterns of theme-lengths include an unordered series of (5,7,6,8) from (C) to (G+2) and symmetrical inversion about (I-4) of 8,10/10,8.

In addition, more speculative, transformational, sequences are given at the bottom of figure 3.3. Changed values are referenced both to a constant value ("m=8") and to previous lengths ("transformation"). Both of these readings of lengths of phrase groups show various lengths without a pattern. Certain values of phrase-group durations do, however, recur; equivalent durations (of 8 mm.) fall at the beginning, middle of section B and end, as well as within section A (5), and adjacent to the partition between section B and the last A (10).

Phrase Structure in
"Putnam's Camp, Redding, Connecticut"

Formal breaks between sections of phrases and themes are clearly defined in this programmatic march.⁶⁹ Ives seems to have closely modeled this piece upon two of his earlier works, Country Band March and Overture 1776, as well as on quoted

⁶⁹The prose-preface, written by Ives, is in appendix 1.

melodies such as the British Grenadiers, Liberty Bell, Battle Cry of Freedom, and bugle calls.⁷⁰

These sources employ four- and eight-measure phrases, and since there are passages that utilize conventional functional harmony, the phrase endings often coincide with harmonic cadences, and sometimes with silence--such as (B-1, b. 4) in example 2.2; this pause is notable because Ives often maintains an ostinato, or an activity that prevents a tutti silence. For example, many of the introductory sections in "Putnam's Camp, Redding, Connecticut," (marked as introductory ["int."] in figure 3.4) end their statements on the V7 chord of the theme that follows.

There are three large sections: A, B, and A¹. Sections B and A¹ are both 50 mm., section A is 63 mm. The two A-sections are so named because of their shared use of themes A, B, and C. The B-section differs by its use of other themes--in section B, many American and British war-songs, and Ives's own Overture 1776 are set over a martial snare- and bass-drum battery. At the end of each section, Ives begins a dense counterpoint coupled with a change in tempo--shown as acceleration ("accel.," or "decel.," for section A) in figure 3.4. Within the sections, there is the unordered thematic-series in section B (as discussed in figure 2.1).

⁷⁰Sinclair, Three Places In New England, iii-iv.

Figure 3.4. Phrase Form in Putnam's Connecticut

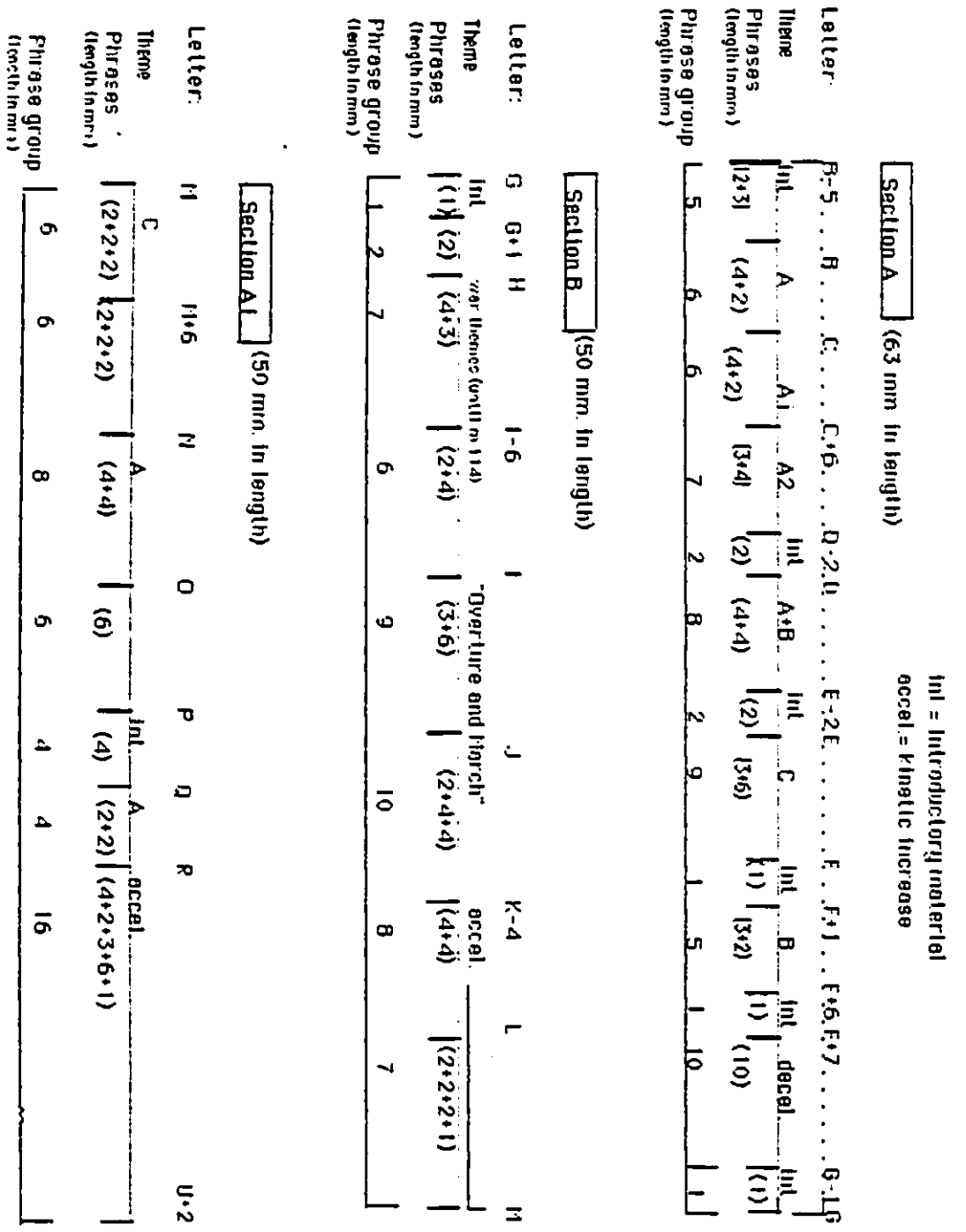

Section A contains phrase-groups that gradually increase in length from 5-mm. to 10-mm.--(5,6,6,7,2,8,2,9,1,5,1,10,1) by increments of +1 measure. The 5-mm. phrases at the beginning and preceding the final 10-mm. phrase comprise a framework for the section in which the basic unit is 5. Section A¹'s phrase-groups have durations of (6,6,8,6,4,4,16) mm. They are divisible by 2 and the changes in length are ± 2 , with the exception of the much longer final phrase-group (16 mm.), unified by its substantial accelerando.

Table 3.1.--Phrase lengths in Three Places In New England

Phrase length (mm.)	"The 'St. Gaudens' in Boston Common"	"Putnam's Camp, Redding, Connecticut"	"from The Housatonic at Stockbridge"
1	1	6	1
2	7	21	12
3	12	7	1
4	8	15	2
6	0	4	0
8	0	0	1
10	0	1	0

Phrase and phrase-group lengths in "Putnam's Camp, Redding, Connecticut" are consistent with those of the other two pieces; most are 1,2,3,4, and 6 measures long.

Phrase Structure in
"from The Housatonic at Stockbridge"

We examined general similarities among the pieces in Three Places In New England as demonstrated in figures 3.1 and 3.2. A significant difference between "from The Housatonic at Stockbridge" and the other pieces is found in its programmatic aspect. It has a linear formal plan that avoids exact repetition; thus it flows in the manner of a "Contented river . . . [to] . . . restive ripple . . . faster drift . . . to the adventurous sea."⁷¹ It is "formally closed . . . an extended paraphrase of a single tune."⁷² Thus, the form does not break or have jarring interruptions; instead, its articulations are subtle.

Figure 3.5 shows one way of organizing the form of the "from The Housatonic at Stockbridge," by theme- and phrase-structure. The first 12 notes of the A-theme are the same as Dorrance and the first 7 notes of Missionary Chant (this is illustrated in example 3.3).⁷³ These pieces are similar in

⁷¹From Robert Underwood Johnson's poem, "The Housatonic at Stockbridge," see the appendix for the rest of this preface.

⁷²Burkholder, Evolution, 324.

⁷³The Missionary Chant or Ember Days and Ordination, composed by Heinrich C. Zeuner in 1832, is the inspirational source for the "from The Housatonic at Stockbridge"; the first seven notes of Ives's first A-theme at (A) are the same as the beginning of the Missionary Chant. The Missionary Chant is provided in appendix 3, from the Episcopalian Hymnal (1904). Dorrance, composer unknown, is more recently thought (Burkholder, Evolution, 271; and Clayton, Tunebook, 194) to be a replacement or addition to the Missionary Chant as a source-

that they share anhematonic pentatonic material (based upon scale-degrees 1,2,3,5,6).

Figure 3.5.--Phrase-form in the "from The Housatonic at Stockbridge"

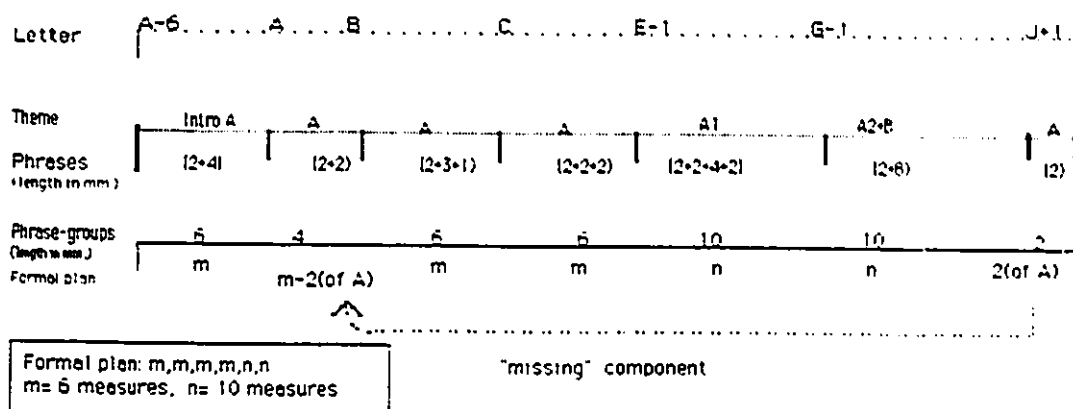

theme in "from The Housatonic at Stockbridge." Clayton, in his Tunebook, attributes (A-4) to (A-1) of the cello, in "from The Housatonic at Stockbridge," to Dorrance--the final six ordered-pitches are the same. Dorrance, from Burkholder's thesis (1983) is also provided in appendix 3. There is room, however, for further study: a comparison of the above source hymns--along with other likely hymns--with all of the melodies in "from The Housatonic at Stockbridge."

Theme A¹ is a variant of the second-half of the A-theme from the Missionary Chant; it continues to emphasize the pentatonic scale, although the melody now begins on the fifth scale-degree of C# minor, versus the third as in previous incipits (found at [A], [B], and [C]).

Example 3.3--The A-theme in "from The Housatonic at Stockbridge," Dorrance, and Missionary Chant

The image displays three staves of musical notation in treble clef. The top staff is labeled "Missionary Chant" and shows a melodic line starting on a G4 note. The middle staff is labeled "Dorrance" and shows a similar melodic line starting on a G4 note. The bottom staff is labeled "from The Housatonic at Stockbridge" and shows a melodic line starting on a G4 note. All three staves show a similar pentatonic-like melodic structure with various intervals and rests.

Theme A¹, at (E-1), changes to the minor mode (C# minor with chromatic alterations) and uses more scalar or passing tones than in previous presentations. Example 3.4 shows theme A at (A) and theme A¹ at (E-1). The melody at (E-1) also changes through an increase in loudness, density, and instrumental assignment (to the increased weight of violin soli with 'cellos), and the melody travels from winds to strings.

In theme A², (G-1), a pentatonic fragment (scale-degrees 3,5,6) is used and this overlaps with a highly contrapuntal B-theme, at (G+1) to (J+1) (as may be seen in example 3.5). Theme B is really many themes combined to form a collage with

Example 3.4--A and A¹ themes in "from The Housatonic at Stockbridge"

(A)

Ma

Tpt

over C#

(E-1)

1

Violins D-III

over C#

Example 3.5--Strata at (G+1) in "from The Housatonic at Stockbridge"

35 *Allergo moderato*

Fl.

Ob.

Cl.

Bsn.

Ma

Tpt

Tromb.

Tuba

Timp.

Piano

Allergo moderato

Viol. sempre (ad lib.)

Viol. sempre (ad lib.)

Violin I

Violin II

Viola

Cello

Bass & Org Ped.

at least five rhythmic, and six linear, strata. The change to the allegro moderato at (G+1) is the most dramatic tempo change in this piece. It is announced by a new rhythmic motive in (G-1) (horns and flute), which interrupts the preceding sustained and unarticulated texture, from (F) to (F+1).

The themes in "from The Housatonic at Stockbridge" are subdivided into their component phrases, which are usually two or four measures in duration, although at (B) to (C), where the phrases are 2+3+1, Ives extends the second phrase, and elides the third, which results in a balance in which the "added" single measure of the second phrase is compensated by "removing" a bar from the second.

The thematic statements create a pattern of durational proportions; their lengths, in measures, are (6, 4, 6, 6, 10, 10, 2). A formal plan is postulated in figure 3.2, with $m = 6$ measures and $n = 10$ measures. Since "m" consists of A-theme material, and the second "m" is short of the norm by 2 measures, the final A-theme, from (J+1) to (J+2), may be viewed as delayed, foreshadowed by its earlier absence.

CHAPTER 4

PARTITIONS AND STRATA IN "FROM THE HOUSATONIC AT STOCKBRIDGE"

In this chapter, I will comprehensively and systematically apply the partitioning criteria, as outlined in chapter 2, to the score of "from The Housatonic at Stockbridge." In particular, I will compare the three most significant partitions (formal boundaries), focusing upon Ives's treatment of pertinent parameters; I will then examine rhythmic and harmonic strata, at these partitions.

Ives's method of organizing strata, segmentation, and transformation is especially interesting in "from The Housatonic at Stockbridge." Unlike "Putnam's Camp, Redding, Connecticut"--whose form at the phrase-level is partially derived from that of the marches quoted, and which has several clear formally unambiguous breaks--"from The Housatonic at Stockbridge" is characterized by a predominance of subtle partitions that disrupt the musical surface. The analysis of surface data indicating partitions is summarized in figure 4.1. An examination of factors that cause these partitions follows.

Three Partitions

There are three partitions in the "from The Housatonic at Stockbridge" that result from conjunctions of numerous changes--marked in figure 4.1A. Figure 4.1B shows the

relative weights of the three main partitions, which occur at (E-1), (G-1), and (J+1).

Figure 4.1A--Partitions in "from The Housatonic at Stockbridge"

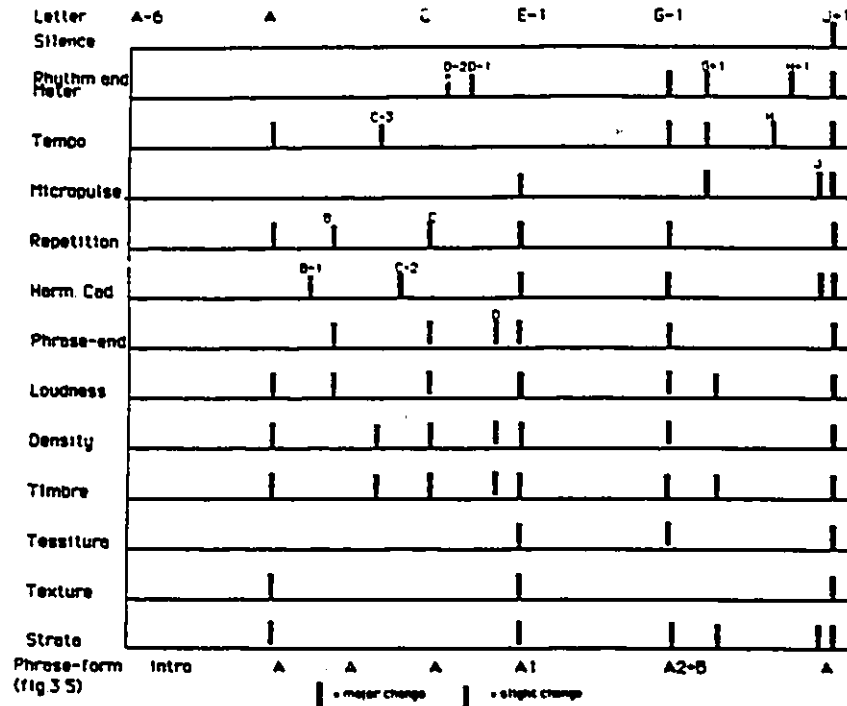
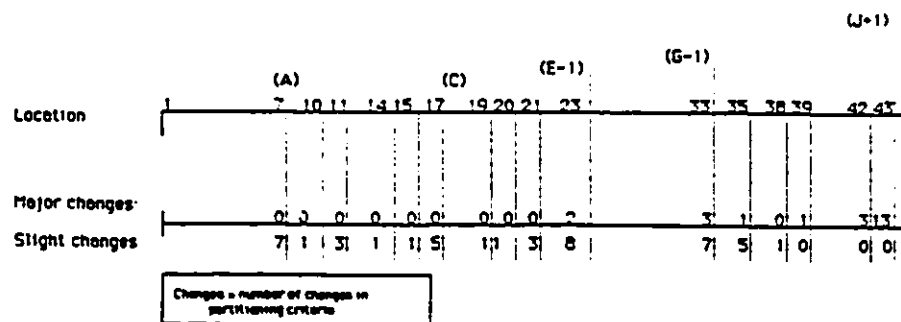

Figure 4.1B--Relative weights of the partitions in "from The Housatonic at Stockbridge"



The strongest partition, which exhibits the greatest number of changed parameters, is at (J+1, beat 4 [b.4]). The three most disruptive partitions are compared in table 4.1--the number and significance of dramatic parametric changes are listed.

Table 4.1--Parametric changes at the significant partitions in "from The Housatonic at Stockbridge"

Partition 1 (E-1)	Partition 2 (G-1)	Partition 3 (J+1)
<u>Major Changes</u>	<u>Major Changes</u>	<u>Major Changes</u>
Repetition Loudness	Rhythm/meter Harmonic Cadence Timbre	Silence Rhythm/meter Tempo Micropulse Repetition Harmonic Cadence Phrase-end Loudness Density Timbre Tessitura Texture Strata
<u>Slight changes</u>	<u>Slight changes</u>	
Micropulse Harmonic cadence Phrase-end Density Timbre Tessitura Texture Strata	Tempo Repetition Phrase-end Loudness Density Tessitura Strata	

These changes increase progressively from partition 1 to partition 3. For example, the marked changes of rhythm, harmonic cadence, and timbre at partition 2 have more weight than do the changes of repetition and loudness at

partition 1. The hierarchy of importance of these parameters is derived from table 2.1 and shown in table 4.1, partition 3, (in descending order on the page). In this case all of the parameters exhibit a major change. The parameters are discussed in their hierarchical order for each partition.

Parametric Changes at Partition 1 (E-1)

Of the three chief partitions, partition 1 (about E-1) has the least number and lowest intensity of changes. There are no interruptions of the musical "flow" in the significant parameters of silence and rhythm. Programmatically, this relatively weak partition might be likened to a "bend" in the Housatonic River.⁷⁴

At partition 1, the A-theme is repeated at (E-1)--shown in example 4.1.

Example 4.1--Theme A at partition 1 versus at (A)

⁷⁴This interpretation assumes Ives's conception of this piece as a metaphor of the river "flowing" from Stockbridge, Massachusetts to the Atlantic, broadening and gathering momentum. See Ives, Memos, 87-88; where Ives describes his inspiration for this piece.

Theme A is notable here because it follows a two-bar introduction, from (D) to (D+1), that has no clearly discernable melody. This theme starts at (E-1) and is a shortened variation of theme A as presented at (A), but transposed by t3.⁷⁵ The A-theme at (E-1) is shorter than (A) and has a compressed range (as may be seen in example 4.1). Partition 1 is marked by a modulation to the relative minor (C# minor), caused by the melodic presentation of a C# minor scale (with chromatic alterations) in the violins and 'cello I. This modulation is accompanied by a de-emphasis of the F-natural (previously in 'cello I), over the C# drone at (E) to (E+2). There is a change in tessitura, after partition 1, to a lower register (c#2-c#1, violins and 'cello I), one octave below the preceding phrase (c#3-c#2, piano and flute, at [D] to [D+1]). The texture-type here changes from chordal, at (D) to (D+1), to contrapuntal, as the new stratum--the string melody at (E-1) appears against the already sounding piano/winds and bass/'cello strata.

Parametric Changes at Partition 2 (G-1)

Partition 2 occurs at (G-1) and marks the beginning of the contrasting B-section--the first instance of increased motion towards the end of the piece (the score states "gradually louder and faster"). At (G), (accel. e cresc a

⁷⁵"t3" = transposed up by three semitones.

poco a poco) Ives begins a kinetic tendency to accelerate, after partition 2, until the climax of this piece at (J). The change at partition 2 is announced by an A-theme variant, which enters at (G-1). The A-theme from (A+1) to (A+3), in the English horn, recurs in the flute and French horn at (G-1); this is shown in example 4.2 and is a change from the preceding passage at (F) to (F+1) that has no distinct melody. This A-theme serves to introduce the B-theme material at (G+1) to (J).

Example 4.2--Theme A at partition 2 versus at (A+1)

At partition 2 rhythmic activity decreases from 10 types of polyrhythms (at F+1, b. 4) to 7 (at G+1, b. 1). These strata of polyrhythms are discussed in connection with figure 4.4, below, where the rhythmic strata may be counted. In addition to the decreased polyrhythms, partition 2 is followed by an increase of tempo (to Allegro mod. from m.m.=44) and micropulse (gradually faster) at (G+1). What is notable here is that partition 2 shows a net rhythmical intensification versus only the slight increase in micropulse

of partition 1 (the melody here includes more eighth notes than before).

Partition 2 includes an unconventional harmonic cadence to F major, through an altered II-I--as illustrated in figure 4.7. This is significant because it is one of the rare cadences of any type; the music prior to (G-1), except for (B+2) to (B+3), features a C# drone throughout until the final V-I to the F# dominant 9th chord in the last bar.⁷⁶

A higher tessitura follows partition 2; this enhanced parameter is reinforced by an increase in loudness and an acceleration of micropulse. Higher ranges are found in flute, clarinet, violins, and piano; all of these instruments rapidly climb one to two octaves at (G-1) to (G). This change continues and is part of the overall kinetic tendency towards increase, expansion and acceleration from (G-1) to (J). New contour-types are also initiated. These are evident in the different pitch contours of (1) ascent--flute, horn, piano left-hand (stems up), (2) descent--bass, bassoon, piano right-hand, (3) no change--trombone, tuba, timpani, violas III, IV, and cellos (4) constant change--violin I, viola II (stems down). These contours are unlike the predominantly static contours in the previous measure.

⁷⁶Ives juxtaposes semitone and whole-tone harmonies such as the chord-C,G,D (viola II at [D]) over chord-C#,G#,F (bass and cellos) and the "G" to "F" collections as shown in figure 4.7.

Parametric Changes at Partition 3 (J+1)

At partition 3 (J+1, b. 4), the rhythmic changes are the following: the metric pulse resumes following a pause (fermata); the tempo changes from Allegro con brio (H+1) to Adagio; the micropulse changes from 32nd notes before the fermata to quarter-note pulses after. Ives uses rhythmical devices both to increase and decrease the intensity of "from The Housatonic at Stockbridge": an increase to (J), and a decrease after, in the contemplative echo of the Dorrance strain from theme A. The climax occurs at (J); most parameters exhibit an increase, expansion or acceleration throughout the piece until (J); partition 3 (J+1) follows the climax and is caused by a drastic decrease, contraction and deceleration in all parameters (see figure 4.1).

At partition 3, repetition occurs after the climax at (J)--the A-theme is restated. The A-theme at (A) (f¹-d^{b1} in the horn is transposed by t3 at (J1) to (J2), to the g^{#2}-e² in violin II at [J+1]). Example 4.3 is a comparison of these two A-themes.

Example 4.3--Theme A at partition 3 versus at (A)

Partition 3 contains a harmonic overlapping of the aggregate at (J) to a 7th chord on C# that cadences to a 9th chord on F# (the dominant)--see example 4.4 for a reduction.⁷⁷ Another reading of these chords might be as a V7-I in F# (downward-stems) and, layered above this, a sustained E-major chord (upward-stems). The changes in range, spacing, and tessitura are pronounced at partition 3, which is not surprising considering the decrease in the number of instruments.

Example 4.4--A harmonic reduction of partition 3

The reduction in range is from a very wide and even dispersion of pitch content (across eight octaves) at (J), to a three-octave span at (J+1), which further reduces to a two-octave span at (J+2).

⁷⁷The C#-chord contains an "added" minor-third, E-natural; the major third, E#, is spelled enharmonically as F-natural.

Changes in the texture-type and number of strata are linked. Figure 4.5 displays the rhythmic strata at partition 3 (discussed later in this chapter). The areas about partition 3--(J-1), (J), and (J+1, b. 4) contain a decrease in the number of strata from 11 to 2. The texture-type changes from the end of the highly contrapuntal B-section at (J-1), to one homophonic stratum at (J), then to (J+1, b. 4), whose outer voices exhibit contrary motion.

Common Parametric Changes among Partitions 1, 2, and 3

All three major partitions follow a phrase completion and initiate a new phrase. The new phrase that follows is, in each case, a variant of theme A (as in examples 4.1, 4.2, and 4.3). At partition 3, there is a change from the climax of the collage made up of B-theme material at (J) to a recapitulation of the A-theme at (J+1). This restatement is an echo of the many repetitions of theme A already heard.⁷⁸

The degree of change in loudness corresponds to the degree of division at each partition. The most drastic change, at partition 3, is from *ffff* to *ppp*; the intermediate partition 2 at (E-1) entails a crescendo from *pp/pppp*⁷⁹ to *mf/f*, which then grows progressively to (J); and the less

⁷⁸This echo is very powerful, even though brief and quiet.

⁷⁹Parts before (E-1) have a dynamic range between *pp* and *pppp*.

substantial change at partition 1 involves a relatively modest change from *pppp* to *mf/f* in the reduced instrumentation of violins and 'cello I.

The degree of change in the number of pitch-classes is a further indicator of the relative weight of partitions. Each partition features a progressively greater decrease in the number of pitch-classes, from just before, to just after; example 4.5 compares these values. At partition 1, there is a reduction of pitch-class content from 9 to 7 (-2); at partition 2, from 11 to 8 (-3); and at partition 3, from 12 to 4 (-8).

Example 4.5--Changes in the number of pitch-classes at three partitions in "from The Housatonic at Stockbridge"

Partition 1 (E-1)

Partition 2 (G-1)

Partition 3 (J+1)

Handwritten musical notation on three staves. Above the first staff are labels (D+1, b.4) and (E-1, b.1). Above the second staff are labels (G-2, b.4) and (J+1, b.3). Above the third staff is a label (J). Between the staves, arrows indicate changes in pitch-class count: from 9 to 7 (-2) between the first and second staves, from 11 to 8 (-3) between the second and third staves, and from 12 to 4 (-8) between the third staff and below it. The numbers 9, 11, 12, 7, 8, and 4 are enclosed in boxes.

Changes in timbral assignment occur at all three partitions; at partition 3, from a full ensemble to low

strings; at partition 2, from strings alone to horn and flute accompanied by strings; and at partition 1, from a *ppp* ensemble to *soli* strings accompanied by the ensemble. These changes also parallel the intensity of the overall partition's change. For example, the timbral shift of partition 3 is extreme versus the subtle change in instruments at partition 1.

Proportional Form

Figure 4.2 presents four proportional formal plans for "from The Housatonic at Stockbridge." The horizontal axes at the top of the figure show keys and scale-resources used for the predominantly melodic materials. The phrase form, based on melody (plan 1), is aligned over partitions weighted according to criteria discussed in chapters 2 and 3 (plan 2). Other proportional schemes that apply to the "from The Housatonic at Stockbridge" are also shown so that various formal interrelationships may be visualized. In figure 4.2, the principal keys are noted in order,⁸⁰ for the main sections of the piece, as derived from figure 4.1 (where many changes on the musical surface signal a partition).

⁸⁰The prioritizing of harmonies at work until (B) is: firstly C#-major in 'cello, bass, and bassoon, which is *p-mp*--"strong enough to throw upper strings into the background," (Ives, Three Places, 65), and secondly, other harmonies sounded in the strings and piano.

The change at (E-1) is to C# minor (with a complex and highly chromatic harmonic background). From this, there is a change at (G-1) to F major (also with a complex background), then to an F# (dominant-9th) at (J+1). Scales used in predominant melodies, as a medium-level component of this piece, are also summarized in figure 4.2. Many layers of melody are present. The most common and most audible scale is the C# pentatonic (1,2,3,5, and 6 scale degrees). This scale is derived from Dorrance and Missionary Chant, the source-hymns for Ives's paraphrased and quoted melody.⁸¹

Formal dividers in "from The Housatonic at Stockbridge" are best viewed as slight articulations, as explained in chapter 2. There are, however, four possible organizational plans of these dividers in the "from The Housatonic at Stockbridge" (figure 4.2 shows these). Scheme 1 shows phrases of the theme A as organically connected, with introductory phrases (denoted by boxes in fig.4.2) leading into presentations of the A-theme or variants (A¹ and A²). Since they are relatively static, the introductory phrases can be heard to preface the melodic presentation of A. Scheme 1 also has the most detailed phrase- and motivic-orientation.

Proportional scheme 2 shows sections based upon intermediate and major partitions from the criteria in figure 4.1 (a) and (b). The findings from figure 4.1 support the

⁸¹See Burkholder, Evolution, 324, 600.

boundaries of phrases in figure 3.5. The coincidence of partitions in plans 1 and 2 simply supports the identification of three main partitions: (E-1), (G-1), and (J+1).

The repetition of theme A at (C), with 5 parametric changes, is a less drastic articulation point than that of (A), with 7 parametric changes. Nonetheless, letter (C) is significant because it is prefaced by a prominent change of instrumental assignment: the striking English horn/viola statement--E-F#-E, at (C-1)--at t6 compared with the G#-A#-G#--bassoon/'cello statement from (A-4) to (A-5), and of the same motive, untransposed, in the English horn from (A+2, bb. 2-4). There is no such drama preceding (B), which has only three slight parametric changes.

Proportional scheme 3 ("River plan") is a programmatic interpretation of the form--see appendix 1C--where the Housatonic River gradually "wanders. . .[and is a]. . . Contented river!" flowing without interruption.

Scheme 4 is a large-scale reading that reveals a symmetrical division about (E-1), the middle of the piece. There are 22 measures on either side of the downbeat of (E-1); this is also the location of a significant tonal change (to the relative minor).⁸²

⁸²Whether the symmetry occurs in performances depends upon the tempo differences throughout the piece, which will determine its clock-time and halves.

An examination of the structure of strata, at the three principal partitions, reveals how Ives utilizes musical elements at these significant locations. A stratum is defined as a cohesive musical unit whose elements share one, and often several characteristic rhythms, pitches, registers, timbres, harmonies, and repeated devices. A given stratum is distinguished from another stratum by differences among these parametric characteristics. Two types of strata-criteria are especially important in "from The Housatonic at Stockbridge": rhythmic and harmonic organization. Other partitioning criteria may also apply towards the determination of a given stratum, but within the compressed area at partitions (1 or 2 measures), the most distinctive parameters are rhythm and harmony.

Much of Ives's music in "from The Housatonic at Stockbridge" articulates various ratios of notes per measure, as well as different groupings within these polyrhythms. Ives discusses this type of polyrhythmic composition in Memos:

To have polyrhythm rise to its full strength, there must be one or a group of players to each rhythm-(by rhythm here I mean something which is only a part of rhythm in its bigger sense- various times of beats to one unit). But if the different meters are played by groups of different sounding units, the effect is valuable, and I believe will be gradually found an important element in deepening and enriching all of

the depths of music, including the emotional and⁷³
spiritual.⁸³

The strata accompanying the melody at partitions 1, 2 and 3 are thus classified by their number "of beats to one unit"--micropulse per measure in this case. The expression R(1) expresses the ratio of beats per one measure: if R(1), then the micropulse in one measure is one duration--a "whole"-note in 4/4 time. As strata in Three Places In New England are occasionally subdivided polyrhythmically within a measure, the ratio of micropulse-per-measure may be selected from the last 1 or 2 beats before or after a partition. This rhythmic "slice" is then multiplied by the appropriate number to obtain a micropulse-per-measure value as near as possible to the partition.

Rhythmic Strata at Partitions 1 and 2

Strata at partitions 1 and 2 share similarities in their organization; both locations feature clearly discernible melodies--louder and of a distinct timbre that is differentiated from the accompaniment--beginning at the partitions. At both partitions, the Dorrance-variants are set with a background of multi-rhythmic strata, which is to be heard "indistinctly" and "as a distant sound."⁸⁴

⁸³Ives, Memos, 124-125.

⁸⁴Ives, Three Places, 74 (D).

Figure 4.3--Rhythmic strata at partition 1

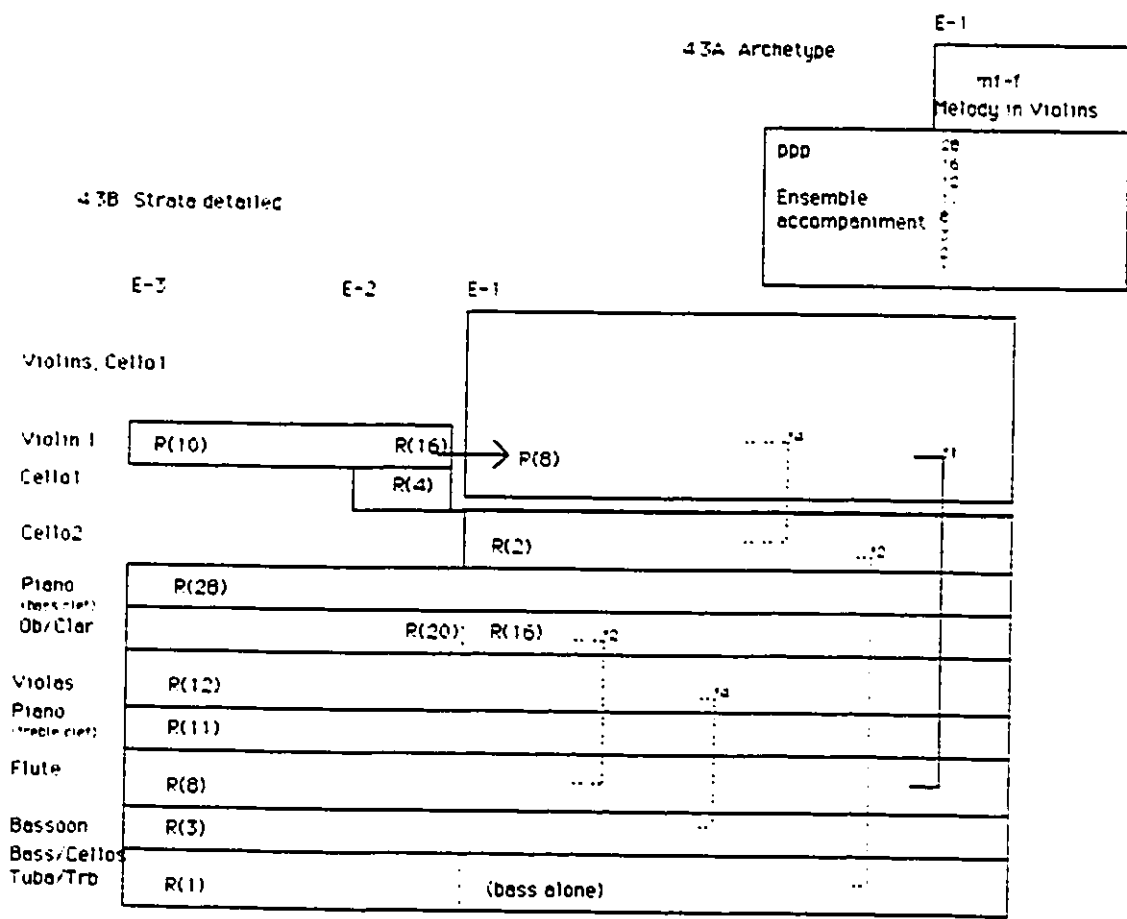

By comparing the archetypes in figures 4.3 and 4.4, one can see the similarity of the superimposed melodic entries at (E-1) and (G-1) solid lines show equivalent R-values. Also, each partition is followed by a large number of rhythmic strata--8 strata at (E-1) and 7 at (G-1). The different R-values are enumerated in figures 4.3A and 4.4A.

Figure 4.4--Rhythmic strata at partition 2

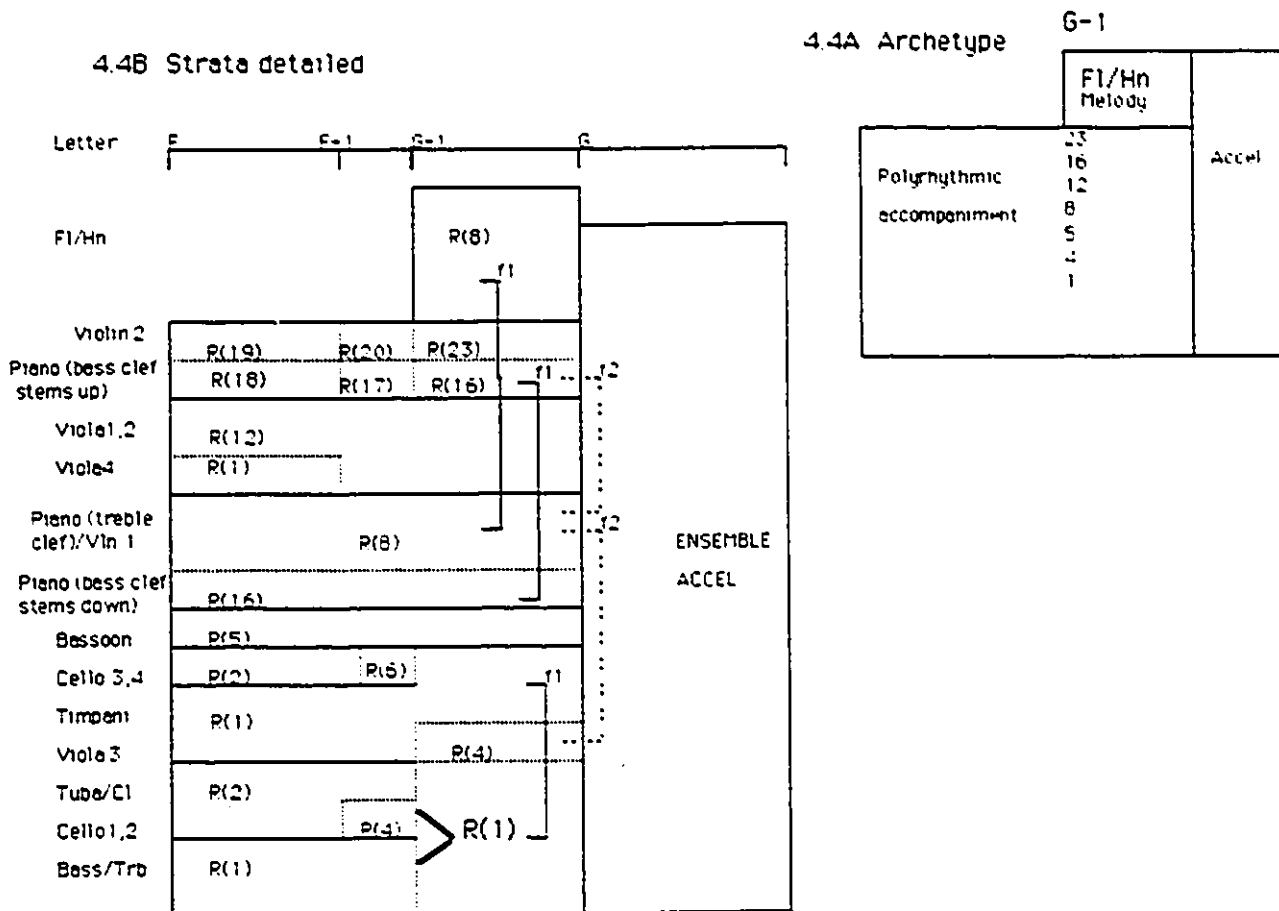

The net effect of all these rhythms is to obscure the bar lines and to create a rhythmic "ebb and flow" around the eighth-note micropulse in the melody and simultaneous downbeats, where many voices coincide (although often Ives assigns slur marks over bar lines).

The groupings of R-values in partition 2 are less concentrated than those of partition 1 at lower R-values (compare this in table 4.2); there are only two conjunct values (versus five in partition 1). Both partitions feature similar collections of the three highest R-values: (12,16,23) in partition 2 versus (12,16,28) in partition 1. Both collections create a similar rhythmic "wash."

Table 4.2--R-values for strata at partitions 1 and 2

Partition 1 R values:	(1,2,3, 8, 11,12, 16, 28)
Partition 2 R values:	(1, 4,5, 8, 12, 16, 23)

R = ratio (micropulse:measure)

Another feature--that of sub-division within a R-value--is illustrated at partition 1: the flute's eighth-note stream is divided into strings of three-groups, which creates a mono-rhythmic, syncopated conflict with the violin line. There is a similar conflict after partition 2, between piano-right-hand and the flute/horn melody where the piano's eighth notes at (G) are grouped as (3+3+2).

The transformation factor (f), analogous to transposition in the domain of pitch, may be applied to the polyrhythms, in figures 4.3, 4.4, and 4.5, to show ratios between R-values. For purposes of comparison, let us assume

that $R(2):R(4)=f2$. That is, the first ratio, multiplied by two, maps it onto the second. Such relationships among strata in partitions 1 and 2 serve as frames of reference for one another. Low values of "f" are significant because they show closer rhythmical relationships among strata. At partition 1, from (E-2) to (E-1), there are two f-relations formed between 'cello 1 and other instruments. There is a linear f2-transformation between 'cello 1 and violins/'cello 1 at (E-1) and a vertical f2-transformation versus flute at (E-2). The 'cello is, in addition, louder than the rest of the ensemble and soloistic in its g#-a line at (E-2); this figure melodically prepares the violin entry at (E-1) by sounding the first note--G#--in advance. Also at partition 1, there is an f4-transformation that links the bassoon (R-value 3) and violas (R-value 12); together these rhythms convey compound rhythms that conflict with the melody (R-value 8).

Rhythmic Strata at Partition 3

This significant partition has overlapping discrete strata-blocks, depicted in the archetype at the top of figure 4.5, in which loudness is the most prominent parameter. The shaded area of stratum 2 in figure 4.5 is not audible until the cessation of stratum 1, at which time the *ppp* can finally be perceived. Figure 4.5B shows the rhythmic constituents of the strata near partition 3 (J+1, b. 4). Stratum 1 is the ensemble in rhythmic unison at *ffff* split by timbre

(specifically, with tremolo as a timbral attribute) into two related groups as shown by a dotted line. The dotted line indicates a subdivision within a stratum. Stratum 2 is also split into two sub-groups, this time by contour (contrary motion) and harmony (the descending line implies E major, the ascending parts imply a V-I in F# major). The triadic-harmonic construction in stratum 2 contrasts strongly against the all-pitch-aggregate at (J).⁸⁵

The change of focus from stratum 1 to 2 is not only marked by reductions of loudness and density-number, but also by the resumption of the metric pulse in stratum 2, a change that has more impact since it follows a suspension of pulse in stratum 1 (even though stratum 2 enters adagio, and pulse is not apparent until [J+2]).⁸⁶ The rhythmic figure found in stratum 2 is an alteration of the A-motive (see example 4.3 for a comparison of Violin II at [J+1] to [J+2] with the horn theme at [A-1] to [A+1]). There are 11 polyrhythmic strata before partition 3 at (J-1, b. 4); four pairs are related by transformation at f2; one of these pairs, bass/tuba/'cello

⁸⁵This aggregate occurs over a clearly iterated C in the four low voices: bass, timpani, bassoon and tuba, although the piano plays an A below. This C/A duality also occurs in "The 'St. Gaudens' in Boston Common," especially at its beginning and end.

⁸⁶Where the pulse has defined its own frame of reference as to its relative proportion versus the underlying meter.

Figure 4.5--Rhythmic strata at partition 3

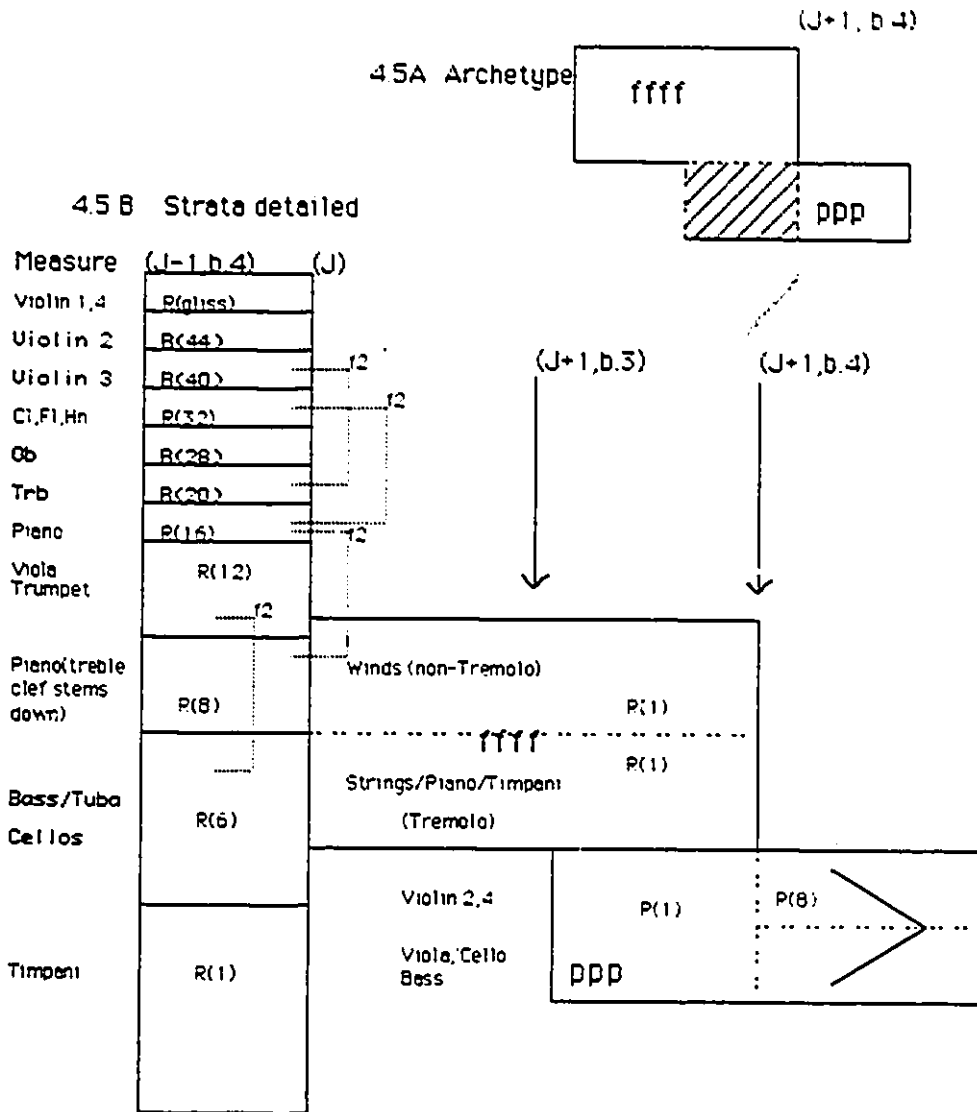

and viola/trumpet, are reinforced by the fact that their R-values, 6 and 12, are both triple subdivisions, unlike the other 9 strata--which employ duple subdivisions.

Like rhythmic strata, Ives's harmonic organization at partitions 1 and 2 is also complex. Pitch-collections are shown in figures 4.6 (partition 1) and 4.7 (partition 2).

The chief harmonic feature at partition 1 is the change in only one stratum--that of the melody in violins and 'cello I--after (E-1). A C#-pedal has been sustained from the beginning of the piece until (G-2). At (E-1), the melody in the strings changes scale-type, from the previous C#-pentatonic⁸⁷ to C#-minor with chromatic embellishments. C#-minor is supported by the open fifth, C#-G#, in the bass and organ pedal, the B-E chromaticisms in upper piano and violin 1, the G#-C# collection in the flute⁸⁸ and G#-C# chromatic in the oboe/clarinet and, finally, by the G#-E of the C#-minor triad in the violas. There is a major/minor duality between the above C#-minor chord-tones and the C#-major in the piano (left hand) and 'cellos (3 and 4).⁸⁹ The greater loudness of the C#-minor melody "softens" the enharmonic "major third" and creates an interesting harmonic colour--predominantly C#-minor with an added, albeit slight, "major-third" quality.

⁸⁷The C#-pentatonic character of the A-theme in "from The Housatonic at Stockbridge" is discussed in chapter 3 and example 3.2.

⁸⁸The flute's C#-minor line, at (D) to (D+1), foreshadows the C#-minor A1-theme at (E-1).

⁸⁹Ives spells the major third of C#--E#--as F.

Figure 4.6--Harmonic strata at partition 1

Letter	D	D-1	E-1	Collection
Flute	G [♯] , A, B, C, C [♯]			G [♯] -C [♯]
Oboe/Clarinet	G [♯] , A, A [♯] , B, C, C [♯] , D			G [♯] -D Chromatic
Piano (treble clef)	B, C, C [♯] , D, D [♯] , E			B-E Chromatic
Violin 1	B, C, C [♯] , D, D [♯] , E, E [♯]	B, A, G, F, E, D, C [♯] , C, B	to violins-below	B-F [♯] chromatic B-B on C-scale with C [♯] access
Piano (bass clef)	C [♯] , G [♯] , B, E, F, D [♯]			C [♯] 7(9) M/m
Violas	C [♯] , G [♯] , E, D [♯] (C, G, D)	C [♯] , A, E, D [♯] (C, G, D)	C [♯] , G [♯] , E, D [♯] (C, G, D)	C [♯] m (9)
Violins/Cello 1	Tacit	D, (D [♯]), E, F [♯] , G [♯] A, B, C [♯] , D		C [♯] minor
Bass/Bsn/Cello2 Tuba/Trb	C [♯] , F, G [♯] , A			C [♯] major



Figure 4.7 is an illustration of more numerous harmonic layers at partition 2 than at partition 1. Here, harmonic strata at (F+1) can be explained as based upon a sonority with G as root, at (F+1), moving at (G-1) to a sonority based on F. The G-root collection at (F+1, bb. 3-4) also includes background material: the C[♯]-major and minor chord-tones in bassoon, piano-right-hand (in the bass clef), and cellos. Furthermore, there are chromatic passages at (G-1) that

define G#-C# and C#-E in piano right-hand (treble clef) and viola, respectively.

Figure 4.7--Harmonic strata at partition 2

Letter	Collection Description		F#1		G-1	
	F#1	G-1				
Fl/Hrn	Tacti	A, C, D				F pentaton fragment
Clar	(Gb), F	E, F				
Bassoon	G, D, (C#)	F, C, (Gb, F, E, Eb, D)	G-C#	F (Passing notes)		
Piano (treble clef)	G# A, A# B, C	C#, B, A	G#-C# Chr	A (Maj)		
Piano (bass clef)	(G, D, (E), F, (G), F, (Bb)) (G#, C#, D#, E#)	(F, C, E)(C, Eb, A)(G#, C#, D), D#, B, E)	G/D#y, C#m	F/A#? (E#), C#m		
Violin 1	G, B (F#, A#) (A, B, C)	C# (Bb, D) (A, C) (G, Bb) (B, D#)	G triad	F (Maj)?		
Violin 2	G# A, B#	(Bb, D) (A, Eb) (C, E)	E-F# Chromatic	E-F# Chromatic		
Viola 1	C, C#, D, C#, E, F, F#	Same as m 32	C#-E Chromatic	E-E Chromatic		
Viola 2	C#, D, E	C, C#, D, E	G (Maj)? chord	F triad (Eb)		
Cello 1,2	Bb, B, (F, C)	E, A	G (Maj)?	F (Maj)?		
Cello 3,4	D, G, (C# D C# E)	F, C	G (Maj)?	F (Maj)?		
Tuba/Trp/Bass	G, D	F (Gb)	G root	F root		

Strata and Partitions of "The 'St. Gaudens' in Boston Common" and "Putnam's Camp, Redding, Connecticut"

There are similarities in the organization of strata, at principal partitions, between "from The Housatonic at Stockbridge" and the other pieces of Three Places In New England. Figure 4.8 illustrates the type and number of strata in the other pieces.

Figure 4.6--Principal strata in "The 'St. Gaudens' in Boston Common" and "Putnam's Camp, Redding, Connecticut" 83

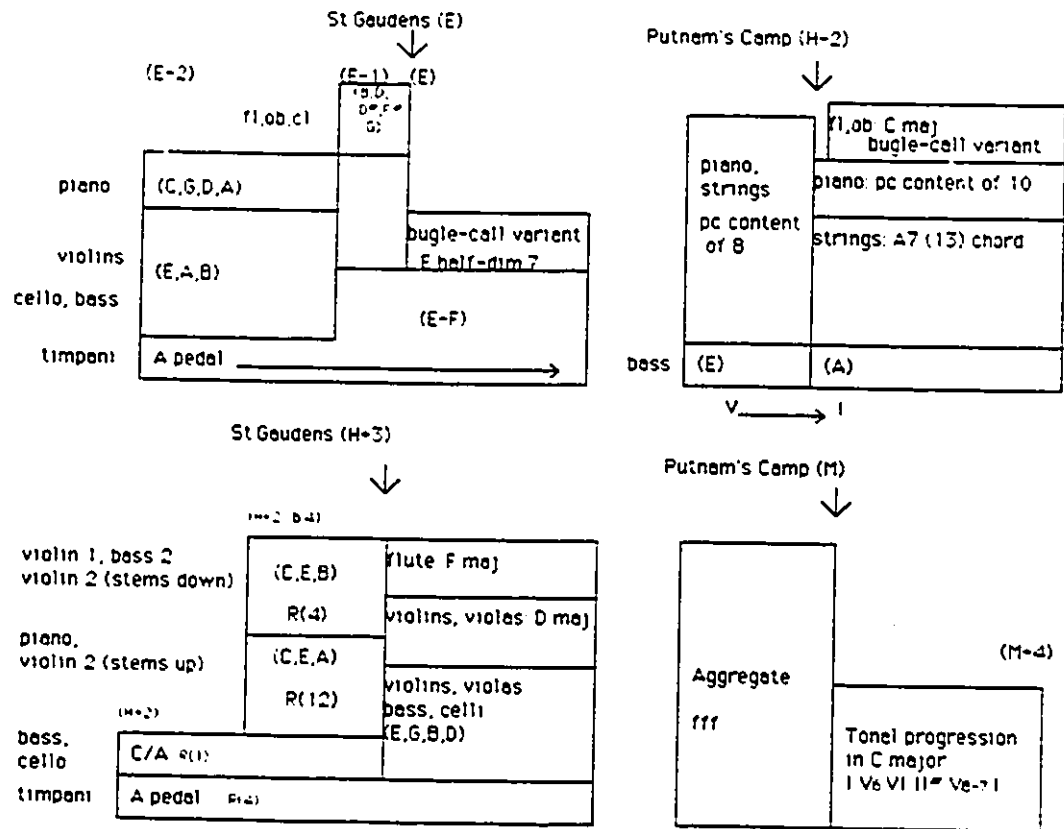

Both "The 'St. Gaudens' in Boston Common" and "Putnam's Camp, Redding, Connecticut" are tripartite: A, B, and A'. Principle partitions exposed by the phrase structure are shown in figures 3.3 and 3.4: in "The 'St. Gaudens' in Boston Common," the main partitions occur at (E) and (H+3), and in "Putnam's Camp, Redding, Connecticut," they occur at (H-2) and (M). Parametric changes support the designations of these locations as the main partitions.

Three of these partitions are stratified: (M) in "Putnam's Camp, Redding, Connecticut" is not (it is similar to partition 3 in "from The Housatonic at Stockbridge"--see figure 4.5).⁹⁰

Of the three stratified partitions in figure 4.8, two feature a bass pedal (provided by timpani) that continues through the partition as in partition 1 from "from The Housatonic at Stockbridge" (in bass and organ). A V-I bass motion occurs at (H-2) of "Putnam's Camp, Redding, Connecticut"; this is akin to the harmonic motion of "II-I"--figure 4.7--at partition 2 in "from The Housatonic at Stockbridge." The strata in figure 4.8 can be classified harmonically; pitch-collections are shown in parenthesis. Occasionally both harmonic and rhythmic classifications apply; for example, after (H+3) in "The 'St. Gaudens' in Boston Common," there are four harmonic collections: (1) the A-pedal, (2) the E-minor seventh chord in celli and bass, (3) the D-major triad (plus added ninth) in violins and violas, and (4) the F-major flute line. However, before (H+3) it is the R-values that show four levels; (H+1) through (H+2) is

⁹⁰Both of these partitions consist of aggregates that change through decreases in density, loudness, and pitch-collection--from aggregate to tonal progression.

introductory and the R-values might be influenced by Ives's "piano-drumming."⁹¹

Ives utilizes a bugle call variant after two of the partitions in "Putnam's Camp, Redding, Connecticut," in order to signal the beginning of a new section (figure 4.6) as well as at several locations throughout Three Places In New England--notably at (U+3), the final notes of "Putnam's Camp, Redding, Connecticut."

⁹¹Ives, Memos, 42-43: "In practising the drum parts on the piano . . . [I played]. . . sets of notes to go with or take-off the drums--for the snare drum, right-hand notes usually closer together--and for the bass drum, wider chords."

CHAPTER 5

CONCLUSIONS

Findings

In this study, I identify the formal partitions found in Three Places In New England. At the main partitions in "from The Housatonic at Stockbridge," I examine both the characteristic and cohesive musical features that define various musical strata, and their interaction with formal partitions.

In measuring musical discontinuities one conclusion is that multiple, simultaneous parametric changes help to account for formal partitions. Partitioning-effects of the parameters from table 2.1 are illustrated in examples from "The 'St. Gaudens' in Boston Common" and "Putnam's Camp, Redding, Connecticut" throughout chapter 2.

One cause of partitions is the boundaries of phrase structures; this is discussed in chapter 3, along with striking similarities among the pieces in Three Places In New England; shared features include those illustrated in figure 3.2: the use of slow tempos, prolonged increases in loudness,

the presence of several strata, and an "Ivesian" coda. Also, I investigate some relationships between phrases and form as well as resultant proportional schemes and consecutive transformation of phrase-lengths: Ives tends to employ irregular phrase-lengths that are often 2, 3, and 4 mm. (as shown in table 3.1). Phrase structure is important both as an indicator of form (suggested by the beginning- and end-points of phrases) and of strata (the melodic phrases can bind more than one instrument together). Some methods of Ives's thematic development are also revealed by the many types of thematic variants--such as transposition--that appear at important partitions; these variants are discussed in chapters 3 and 4.

Proportional schemes exhibiting asymmetry predominate in Three Places In New England; the "The 'St. Gaudens' in Boston Common" and "Putnam's Camp, Redding, Connecticut" exhibit an asymmetrical progressive transformation of their phrase-lengths (shown in figures 3.3, 3.4, and 3.5). Symmetrical proportional schemes are occasionally employed by Ives; an example of this is the phrase-group lengths in "from The Housatonic at Stockbridge" (described in figure 3.5). In addition, kinetically changing passages, are present in Three Places In New England (as in "Putnam's Camp, Redding, Connecticut," figure 3.4). Kinetic form is especially apparent throughout "from The Housatonic at Stockbridge," where the succession of partitions exhibits a tendency for

the parametric changes to be characterized by increase or intensification in the number and quality of events observed. "Putnam's Camp, Redding, Connecticut" features sections that exhibit similar kinetic tendencies (as detailed in figure 3.4).

The coincidence of phrase structure, parametric changes, and changes in keys and scalar resources is graphed in chapter 4 (in figure 4.2), the most common types of parametric and thematic changes at each partition are discussed.

Musical features at the main partitions are then examined to determine what grouping (or segmentation) of elements are strata. Polyrhythms and keys or chords are analyzed, and prove to be strata-defining elements. The findings of chapter 4 include the presence of strata at partitions that illustrate simultaneous and binding polyrhythmic and harmonic devices used by Ives throughout Three Places In New England. Cohesive musical features are shown as discrete strata characterized by harmonic and rhythmic features in figures 4.3 through 4.8.

A similar process of strata analysis, applied to selected significant partitions in the rest of Three Places In New England, reveals that strata in the other pieces operate in a similar manner to those in "from The Housatonic at Stockbridge." Such similarities among pieces include the occasional employment, by Ives, of multiple harmonic and/or rhythmic strata. These strata often coincide with significant

partitions; this coincidence both causes and accentuates the formal boundaries.

"Larger" questions about Ives's music are also answered. By studying the form of Three Places In New England one can assert that this music is structured--"The 'St. Gaudens' in Boston Common" and "Putnam's Camp, Redding, Connecticut" are tripartite forms and "from The Housatonic at Stockbridge" is a continuous nonrecursive form. Phrase-form, however, tends to be irregular. There are several types of pitch-organization in Three Places In New England: (1) tonal sections, (2) tonal sections combined with complex, highly chromatic "backgrounds," and (3) aggregates. Ives also utilizes syncopation and occasionally combines this with multiple metrical subdivisions (often, each metrical subdivision defines a stratum).

In Three Places In New England, Ives implements his inspirational programs and attempts to communicate their messages--this process of implementation includes many sudden and dramatic or gradual and kinetic parametric changes as well as references to quotations (with their attached images).

Issues and Problems in Determining Partitions and Strata

In brief, the object of this analytic study is to determine the locations of important formal boundaries in

Three Places In New England and to examine the nature of musical materials at its formal partitions. Issues and problems arise in the process of carrying out this research.

Even though tonal features are evidenced by the chords, scales, and harmonic progressions found in Three Places In New England--as illustrated in examples 4.6, 4.7, and 4.8, and throughout chapter 3 (in the discussion of Ives's themes)--the meaning of "tonality" in Ives's music is often obscured. For example, at (J+1) in "from The Housatonic at Stockbridge," Ives moves from an aggregate to a brief "tonal" passage (the final cadence to F#). A long kinetic acceleration, (G) to (J), precedes the aggregate and consists of a highly complex and chromatic music, with the result that the tonal frame-of-reference is suspended for these 9 measures. Three very different types of "tonal" music occur from (J-1) to (J+1); in these varied tonal styles one could apply, in order, set-theory, aggregate theory,⁹² and conventional functional harmonic analysis. It is difficult, though, to apply a single technique of harmonic analysis to a piece of such a varied and changing nature and obtain consistently meaningful results.

Structural organization at the medium- and large-scale levels can be ascertained in the phrase-structural and proportional schemes as described in chapters 3 and 4

⁹²As developed by Lambert in "Aggregate Structures."

(especially figure 4.2). One issue regarding the organization of phrase-lengths--given Ives's classical and romantic influences--arises: is Ives a formal "neo-classicist" who deliberately obscures regular formal boundaries, or, is he operating in a new asymmetrical formal mode? I contend that the former hypothesis is supported by the phrase-form graphs (in chapter 3) as well as the discussion of Ives's varied (and eclectic) influences surveyed in chapter 1.

There are other difficulties inherent in the analysis of this music. They include (1) tracing the origin and subsequent manipulation of quotations where Ives combines several sources with similar characteristic intervals, as shown in examples 3.2 and 3.3, and (2) accounting for linear note-choices in the many dense and compact pc areas in Three Places In New England. By referring to the sketches one can sometimes see how Ives "built up" his counterpoint or harmonic densities.

Future Research

The process of completing this study, thinking about Ives's music and developing analytical techniques to overcome "difficulties" inherent in Three Places In New England, suggests directions for future research. Possible topics are:

(1) Two different analyses of a selection of Ives's pitch-collections, one in a tonal and another in post-tonal set-theoretic context.

(2) Sketch-studies to ascertain Ives's process in building up strata and obscuring both formal boundaries (from regular 4 and 8 measure forms) and underlying harmonic progressions.

(3) A study of the effectiveness and idiosyncrasies of Ives's rhythmic vocabulary and its notation. Such a study could address the complexity of the polyrhythms conceived by Ives, and how to best convey them. Also, the implications towards quarter-tone or flexible tuning from Ives's unusual enharmonic notation (Ives has been recorded singing "They Are There,"--his pitch-sense could be analyzed)

(4) A clearer understanding of precise dates of Ives's compositional innovations--further research along the lines taken by Solomon and Lambert.⁹³ This would enable a more accurate application of historical parallels between Ives, Schoenberg, and Debussy.

(5) The relationships between Ives's music and the literal or metaphoric meanings of implied texts. Here the researcher might superimpose the quoted texts in order--upon selected scores--to discover the underlying textual meaning (as I have done in chapter 3, pp. 43-45). A study of Ives's methods of program implementation could include an

⁹³See articles discussed in chapter 1: Solomon, "Veracity," Lambert, "Reply," and Baron, "Dating."

examination of dramatic, kinetic changes and their relationship to Ives's "story."

(6) The relationships between quoted tunes and their settings; this could be accomplished by overlaying and comparing the melodies and harmonies of Ives's quotes with Ives's setting of same--to discover how the two sources are related. Also, an examination of the rationale for Ives's quotation choices--is his quotation-vocabulary a typical New-England-selection, or did Ives favour particular types of melodies, harmonic progressions and texts? This topic could be approached through a comparative survey of Ives's quotations.

Appendix 1A--Preface to "The 'St. Gaudens' in Boston Common"

I.

The 'St. Gaudens' in Boston Common
(Col. Shaw and his Colored Regiment)

MOVING,—Marching—Faces of Souls!

Marked with generations of pain,

Part-freers of a Destiny,

Slowly, restlessly—swaying us on with you

Towards other Freedom!

The man on horseback, carved from

A native quarry of the world Liberty

And from what your country was made.

You images of a Divine Law

Carved in the shadow of a saddened heart—

Never light abandoned—

Of an age and of a nation.

Above and beyond that compelling mass

Rises the drum-beat of the common-heart

In the silence of a strange and

Sounding afterglow

Moving—Marching—Faces of Souls!

II.

NEAR Redding Center, Conn., is a small park preserved as a Revolutionary Memorial; for here General Israel Putnam's soldiers had their winter quarters in 1778-1779. Long rows of stone camp fire-places still remain to stir a child's imagination. The hardships which the soldiers endured and the agitation of a few hot-heads to break camp and march to the Hartford Assembly for relief, is a part of Redding history.

Once upon a "4th of July," some time ago, so the story goes, a child went there on a picnic, held under the auspices of the First Church and the Village Cornet Band. Wandering away from the rest of the children past the camp ground into the woods, he hopes to catch a glimpse of some of the old soldiers. As he rests on the hillside of laurel and hickories, the tunes of the band and the songs of the children grow fainter and fainter;—when—"mirabile dictu"—over the trees on the crest of the hill he sees a tall woman standing. She reminds him of a picture he has of the Goddess of Liberty,—but the face is sorrowful—she is pleading with the soldiers not to forget their "cause" and the great sacrifices they have made for it. But they march out of camp with fife and drum to a popular tune of the day. Suddenly a new national note is heard. Putnam is coming over the hills from the center,—the soldiers turn back and cheer. The little boy awakes, he hears the children's songs and runs down past the monument to "listen to the band" and join in the games and dances.

The repertoire of national airs at that time was meagre. Most of them were of English origin. It is a curious fact that a tune very popular with the American soldiers was "The British Grenadiers." A captain in one of Putnam's regiments put it to words, which were sung for the first time in 1779 at a patriotic meeting in the Congregational Church in Redding Center; the text is both ardent and interesting.

III.

from The Housatonic at Stockbridge

Robert Underwood Johnson.

“**C**ONTENTED river! in thy dreamy realm—
 The cloudy willow and the plummy elm. . .

Thou hast grown human laboring with men
 At wheel and spindle; sorrow thou dost ken; . . .

Thou beautiful! From every dreamy hill
 What eye but wanders with thee at thy will,
 Imagining thy silver course unseen
 Convoys by two attendant streams of green. . . .

Contented river! and yet over-shy
 To mask thy beauty from the eager eye;
 Hast thou a thought to hide from field and town?
 In some deep current of the sunlit brown
 Art thou disquieted—still discontent
 With praise from thy Homeric bard, who lent
 The world the placidness thou gavest him?
 Thee Bryant loved when life was at its brim; . . .

Ah! there's a restive ripple, and the swift
 Red leaves—September's firstlings—faster drift;

Wouldst thou away!
 I also of much resting have a fear;
 Let me thy companion be
 By fall and shallow to the adventurous sea!”

Appendix 2-- Ives's Notes on the Fourth Violin Sonata

NOTES ON FOURTH VIOLIN SONATA

This sonata is the fourth for violin and piano. It is called "CHILDREN'S DAY AT THE CAMP MEETING". It is shorter than the other violin sonatas, and a few of its parts and suggested themes were used in organ and other earlier pieces. The subject matter is a kind of reflection, remembrance, expression, etc. of the children's services at the out-door Summer camp meetings held around Danbury and in many of the farm towns in Connecticut, in the 70's, 80's and 90's. There was usually only one Children's Day in these Summer meetings, and the children made the most of it—often the best of it. They would at times get stirred up, excited and even boisterous, but underneath there was usually something serious, though Deacon Grey would occasionally have to "Sing a Caution".

The First Movement (which was sometimes played last and the last first)—was suggested by an actual happening at one of these services. The children, especially the boys, liked to get up and join in the marching kind of hymns. And as these meetings were "out-door", the "march" sometimes became a real one. One day Lowell Mason's—"Work for The Night is Coming" got the boys going and keeping on between services, when the boy who played the melodeon was practicing his "organicks of canonicks, fugaticks, harmonicks and melodicks". In this movement, as is remembered, they—the postlude organ practice (real and improvised, sometimes both)—and the boys' fast march—got to going together, even joining in each other's sounds, and the loudest singers and also those with the best voices, as is often the case, would sing most of the wrong notes. They started this tune on "ME" so the boy organist's father made him play "SOH" hard even if sometimes it had to be in a key that the postlude was not in just then. The boys sometimes got almost as far off from Lowell M. as they did from the melodeon. The organ would be uncovering "covered 5ths" breaking "good resolutions" faster and faster and the boys' march reaching almost a "Main Street Quick-step" when Parson Hubbell would beat the "Gong" on the oaktree for the next service to begin. Or if it is growing dark, the boys' march would die away, as they marched down to their tents, the barn doors or over the "1770 Bridge" between the Stone Pillars to the Station.

The Second Movement is quieter and more serious except when Deacon Stonemason Bell and Farmer John would get up and get the boys excited. But most of the Movement moves around a rather quiet but old favorite Hymn of the children, while mostly in the accompaniment is heard something trying to reflect the out-door sounds of nature on those Summer days—the west wind in the pines and oaks, the running brook—sometimes quite loudly—and maybe towards evening the distant voices of the farmers across the hill getting in their cows and sheep.

But as usual even in the quiet services, some of the deacon-enthusiasts would get up and sing, roar, pray and shout but always fervently, seriously, reverently—perhaps not "artistically"—(perhaps the better for it).—"We're men of the fields and rocks, not artists". Farmer John would say. At times these "confurorants" would give the boys a chance to run out and throw stones down on the rocks in the brook! (*Allegro conlugarocko!*)—but this was only momentary and the quiet Children's Hymn is sung again, perhaps some of the evening sounds are with it—and as this Movement ends, sometimes a distant Amen is heard—if the mood of the Day calls for it—though the Methodists and Baptists seldom called for it, at the end of their hymns, yet often, during the sermon, an "Amen" would ring out as a trumpet call from a pew or from an old "Amen-Seat". The Congregationalists sometimes leaned towards one, and the Episcopalians often.

The Third Movement is more of the nature of the First. As the boys get marching again some of the old men would join in and march as fast (sometimes) as the boys and sing what they felt, regardless—and—thanks to Robert Lowry—"Gather at the River".

NOTE: The above is mostly from remarks written on the back of some of the old music manuscripts.

Appendix 3--Missionary Chant and Dorrance

221 **Ember Days and Ordination**
L. M.

MISSIONARY CHANT *With vigor* HEINRICH C. ZEUBER, 1832

1 Ye Chris-tian her-alds, go, pro-claim Sal-va-tion in Eas-
2 God shield you with a wall of fire, With ho-ly zeal your
3 And when our la-bors all are o'er, Then may we meet to

man-uel's Name: To dis-tant climes the ti-dings
hearts in-spire, Bid ra-ging winds their fu-ry
part no more, Meet, with the ran-somed throng to

bear, And plant the Rose of Sher-on there.
cease, And calm the sav-age breast to peace.
fall, And crown the Sa-voir Lord of all. A-men.

Alternative Tune, DUKE STREET, No. 148 BOURNE HALL DRAPER, 1803, alt.

Also the following:

- 109 Come, thou Holy Spirit, come
- 371 Creator Spirit, by whose aid
- 573 Go, labor on! spend and be spent
- 131 God, deigning man to be
- 377 Holy Spirit, Truth divine
- 268 I bind unto myself to-day
- 574 Lord, speak to me, that I may speak
- 575 Lord, who didst send, by two and two before thee
- 108 O come, Creator Spirit, come
- 256 O Spirit of the living God
- 535 Rise up, O men of God

Dorrance

From Burkholder, "Evolution" 600.

A SELECTED BIBLIOGRAPHY OF CHARLES IVES AND HIS MUSIC,
WITH AN EMPHASIS ON ANALYTICAL/THEORETICAL STUDIES

- Albert, Thomas, R. "The Harmonic Language of Charles Ives's Concord Sonata." D.M.A. diss., University of Illinois, 1974.
- Baron, Carol. "Dating Charles Ives's Music: Facts and Fictions." Perspectives of New Music 28, no.1 (Winter 1990): 20-56.
- Brooks, William. "Unity and Diversity in Charles Ives's Fourth Symphony." Yearbook for Inter-American Research 10 (1974): 5-49.
- _____. "Ives Today." In An Ives Celebration, ed. E. Wiley Hitchcock and Vivian Perlis, 145-223. Urbana, Chicago, London: University of Illinois Press, 1977.
- _____. "A Drummer-Boy Looks Back: Percussion in Ives's Fourth Symphony." Percussionist 22, no.6 (1984): 4-45.
- Block, Geoffrey. Charles Ives: A Bio-Bibliography. New York, Westport, Connecticut, London: Greenwood Press, 1988.
- Burkholder, Peter. "The Evolution of Charles Ives's Music: Aesthetics, Quotation, Technique." Ph.D. Diss., University of Chicago, 1983.
- _____. Charles Ives: The Ideas Behind the Music. New Haven: Yale University Press, 1985.
- _____. "Charles Ives: Quotation." Musical Quarterly 71 (1985): 1-26.

- _____. "Quotation and Paraphrase in Ives's Second Symphony." 19th Century Music 11, no.1 (Summer, 1987): 3-25.
- _____. "The Critique of Tonality in the Early Experimental Works of Charles Ives." Music Theory Spectrum 12, no. 2: 203-223.
- Cowell, Henry and Sidney. Charles Ives And His Music. London: Oxford University Press, 1969.
- De Lerma, Dominique-Rene. Charles Ives, 1874-1954: A Bibliography of His Music. Kent, Ohio: Kent State University Press, 1970.
- H. Wiley Hitchcock and S. Sadie, eds. The New Grove Dictionary of American Music. London: Macmillan, 1985. S.v. "Charles Ives," by Paul Echols.
- Forte, Allen. "Ives and Atonality." In An Ives Celebration, eds. H. Wiley Hitchcock and Vivian Perlis, 159-186. Urbana, Chicago, London: University of Illinois Press, 1977.
- Gingerich, Lora L. "A Technique for Melodic Motivic Analysis in the Music of Charles Ives." Music Theory Spectrum 8 (1986): 75-93.
- Henderson, Clayton W. The Charles Ives Tunebook. Michigan: Harmonie Park Press, 1990.
- Hilliard, John Stanley. "Charles Ives's Robert Browning Overture: Style and Structure." D.M.A. diss., Cornell University, 1983.
- Hitchcock, H. Wiley, Ives. London: Oxford University Press, 1977.
- Hitchcock, H. Wiley and Perlis, Vivian. An Ives Celebration. Urbana: University of Illinois Press, 1977.

- Ives, Charles E. "Conductor's Note" in Ives's Fourth Symphony.
New York: Associated Music, 1965.
- _____. Essays Before A Sonata and Other Writings.
Edited by Howard Boatwright. New York: Norton and
Company, 1962.
- _____. "Notes on the Fourth Symphony." New Music 2 no. 2
(Jan.1929).
- Ives, Charles E. Memos. Edited by John Kirkpatrick. New York:
Norton and Company, 1991.
- _____. 114 Songs. U.S.A.: National Institute of Arts and
Letters, 1975.
- _____. Autograph sketches of Three Places In New England.
New Haven: Library of the Yale School of Music.
- Kirkpatrick, John. A Temporary Mimeographed Catalogue of the
Music Manuscripts and Related Materials of Charles
Edward Ives 1874-1954. New Haven: Library of the Yale
School of Music, 1960 (reprint 1973).
- Lambert, Philip. "Reply to Solomon." Journal of the American
Musicological Society 62 (Spring 1989): 204-9.
- _____. "Aggregate Structures in the Music of Charles
Ives." Journal of Music Theory 34, no.1 (Spring 1990):
29-56.
- _____. "Intervallic Cycles as Compositional Resources in
the Music of Charles Ives." Music Theory Spectrum 12
(1990): 43-82.
- Maisel, Arthur. "The Fourth of July by Charles Ives: Mixed
Harmonic Criteria in a Twentieth-Century Classic."
Theory and Practice 6, no.1 (1981): 3-32.
- Morgan, Robert P. "Spatial Form in Ives." In An Ives
Celebration, eds. H. Wiley Hitchcock and Vivian
Perlman, 145-158. Urbana, Chicago, London: University of
Illinois Press, 1977.

- Nelson, Mark D. "Beyond Mimesis: Transcendentalism and Processes of Analogy in Charles Ives's The Fourth of July." Perspectives of New Music 22, no's. 1-2 (1984): 353-364.
- Perlis, Vivian. Charles Ives Remembered. New Haven and London: Yale University Press, 1974.
- _____. "Charles Ives Papers." Yale University Music Library Archival Collection Mss 14. Unpublished (1983).
- Reed, Joseph W. Three American Originals. Middletown, Connecticut: Wesleyan University Press, 1984.
- Rossiter, Frank R. Charles Ives and His America. New York: Liveright, 1975.
- Sadie ed. The New Grove Dictionary of Music and Musicians. London: Macmillan, 1980. S.v. "Ives, Charles E." by John Kirkpatrick.
- Schoffman, Nachum. "The Songs of Charles Ives." Ph.D. diss., Hebrew University, 1975.
- Slonimsky, Nicholas, ed. Baker's Biographical Dictionary of Musicians, 6th edition, 1978. S.v. "Charles Ives," by Nicholas Slonimsky.
- _____. Perfect Pitch. Oxford: Oxford University Press, 1988.
- Solomon, Maynard. "Charles Ives: Some Questions of Veracity." Journal of the American Musicological Society 40 (Fall 1987): 443-470.

_____. "Rebuttal to Lambert's reply", re:
"Charles Ives: Some Questions of Veracity." Journal of
the American Musicological Society 62 (spring 1989):
209-18.

Stein, Alan. "The Musical Language of Charles Ives's Three
Places in New England." D.M.A. diss., University of
Illinois, 1975.

Winters, Thomas Dyer. "Additive and Repetitive Techniques in
the Experimental Works of Charles Ives." Ph.D. diss.,
University of Pennsylvania, 1986.

Wooldridge, David. From the Steeples and Mountains. New York:
Knopf, 1974.

OTHER THEORETICAL STUDIES CONSULTED

Berry, Wallace. Structural Functions in Music. New York:
Dover, 1987.

Hasty, Christopher. "Segmentation and Process in Post-Tonal
Music." Music Theory Spectrum (1981): 54-73.

Parks, Richard. The Music of Claude Debussy. New Haven: Yale
University Press, 1989.

COLLECTIONS

New Haven. Ives Collection. John Herrick Jackson Music Library. Yale University. P.O. Box 2104A, Yale Station, New Haven, CT 06520-7440.

New York. Music Division. The New York Public Library at Lincoln Center. 111 Amsterdam Av. at 65th St. New York, New York, 10023.

Washington D.C. The Music Division of the Library of Congress. Washington, D.C., 20540.

MODERN EDITIONS

Ives, Charles. Three Places In New England. Boston: C.C. Birchard [Mercury Music Corporation], 1935.

_____. Three Places in New England. Edited by James B. Sinclair. Bryn Mawr, Pennsylvania: Mercury Music Corporation, 1976.

RECORDINGS

Ives, Charles. Three Places In New England. Boston Symphony Orchestra, conducted by Michael Tilson Thomas. Compact disc 423 243-2. Deutsche Grammophon, 1970.

_____. Three Places in New England. Orchestra New England, conducted by James Sinclair. Compact disc 3-7025-2 H1. Koch, 1990.