

Protection and Restoration Schemes in Elastic Optical Networks

Melissa Stapleton

A thesis submitted in partial fulfillment of the requirements for the
MSc Degree in Electrical and Computer Engineering

School of Electrical Engineering and Computer Science

Faculty of Engineering

University of Ottawa

© Melissa Stapleton, Ottawa, Canada, 2018

Abstract

Elastic optical networks (EON) are an emerging solution to improve the capacity and flexibility of optical transport networks. EONs are comprised of a flexgrid spectrum, bandwidth variable transponders (BVT), and supporting optical cross connections. The evolution of EONs has facilitated the grouping of optical signal carriers, or network media channels (NMC), into parent media channels (MC). Concatenating NMCs, which traverse the same source to destination, into a MC reduces the requirement for guard-bands between channels. This provides an opportunity to treat multiple channels as a single entity in routing algorithms, spectrum assignment, and survivability schemes. The literature review conducted in this thesis found that the research in the protection and restoration schemes utilizing NMC and MC entities is lacking. This thesis aims to provide different proposals for both protection and restoration that enhance the survivability, flexibility, and spectral efficiency of EONs. Through MC and NMC identifiers, protection or restoration schemes are employed with an associated Class of Service (CoS) to an individual NMC or a MC as a whole entity. The protection schemes proposed in this thesis are; selected, divided, and mixed protection. Selected protection aims to reduce the required reserved resources by only protecting high priority traffic within a MC. Divided protection offers flexibility by dividing protection resources in a MC to multiple protection paths. Mixed protection incorporates both selected and divided protection into one scheme. The protection schemes are analyzed against the pre-existing dedicated protection. Restoration schemes are also proposed in this thesis. The novel approach to restoration drops lower priority NMCs in the event of a link fault when there is insufficient spectrum to restore all NMCs within an MC. The proposed restoration scheme is compared to fundamental restoration techniques, that are available in the predecessor fixed grid networks. The proposed approaches in protection and restoration provide a solution to flexgrid survivability implementations and improve the efficiency of spectrum protected and restored in the event of a single link failure.

Acknowledgments

I would first like to express my gratitude towards my thesis supervisor, Prof. Hussein T. Mouftah, for his exceptional advice, guidance, and support during my research. Prof. Mouftah continuously made himself available whenever I had a question about my research or writing.

I would also like to thank Dr. Khaled Maamoun, who worked with me diligently and frequently throughout my thesis. Dr. Maamoun offered creative ideas and challenged me to think outside the box.

I would also like to acknowledge Dr. Nabil Naas who provided valuable comments throughout my research and publications.

Finally, I am grateful to my partner, Brandon Pynn, and my family for providing me with unwavering support and continuous encouragement throughout my years of study and through the process of researching and writing this thesis. This accomplishment would not have been possible without them. Thank you.

Table of Contents

Chapter 1. Introduction	1
1.1 Background	1
1.2 Motivation	2
1.3 Objectives	2
1.4 Thesis Contribution	3
1.5 Thesis Outline	3
Chapter 2. Background and Technology Survey	5
2.1 Introduction	5
2.2 Protection and Restoration in Fixed Grid Networks	5
2.3 Elastic Optical Networks and Supporting Technology	13
2.4 Proposed Survivability Schemes in Elastic Optical Networks	18
Chapter 3. System Design	28
3.1 Introduction	28
3.2 Proposed Protection Scheme	29
3.2.1 Protection types	29
3.2.2 Protection Architecture	32
3.3 Proposed Restoration Scheme	35
3.4 Protection and Restoration Implementation	46
3.5 Spectrum and routing management	49

Chapter 4. Performance Evaluation	51
4.1 Introduction	51
4.2 NSFNET Network.....	51
4.3 Protection Simulation.....	52
4.3.1 Protection Assumptions	53
4.3.2 Protection Media and Network Media Channels	54
4.3.3 Protection Routing and Spectrum Assignment.....	55
4.4 Restoration Simulation	56
4.4.1 Restoration Assumptions	56
4.4.2 Restoration Media and Network Media Channels	57
4.4.3 Restoration Routing and Spectrum Assignment.....	58
Chapter 5. Results	59
5.1 Protection results.....	59
5.2 Restoration Results	68
5.3 Confidence Interval	86
Chapter 6. Conclusions and Future Work	88
6.2 Conclusions	88
6.2 Future Work	90
References	92

List of Figures

Fig. 2.1: Overview of Survivability Techniques in Optical Networks [2].....	6
Fig. 2.2: 1+1 Protection, 1:1 Protection, 1:N Protection [RAM10].....	7
Fig. 2.3: Shared Protection Path Examples [SIM16]	9
Fig. 2.4: Protection Architectures [SIM16].....	10
Fig. 2.5: Restoration Types [SOM06].....	11
Fig. 2.6: Composition of a Media Channel [GON15]	14
Fig. 2.7: Fixed Grid vs Flexible Grid Spacing	15
Fig. 2.8: SLICE Architecture [JIN09]	19
Fig. 2.9: Bandwidth squeezed restoration [SON11].....	21
Fig. 2.10: Subcarrier Module Restoration [TAN15].....	23
Fig. 2.11: Dedicated protection schemes [LAY18]; a) Single wavelength on working path, b) Wavelength on both working and protection path.....	24
Table 2.3: Modulation Format-Aware before restoration	25
Table 2.4: Modulation Format-Aware after restoration	26
Fig. 3.1: Media and Network Media Channel Representation	28
Fig. 3.2: Dedicated Protection in EON	30
Fig. 3.3: Selected Protection in EONs.....	30
Fig. 3.4: Divided Protection in EONs.....	31
Fig. 3.5: Mixed Protection in EONs.....	32
Fig. 3.6: Dedicated Protection Architecture.....	33
Fig. 3.7: Selected Protection Architecture	33
Fig. 3.8: Divided Protection Architecture	34
Fig. 3.9: Mixed Protection Architecture	35

Fig. 3.10: Restoration High Level Flowchart	36
Fig. 3.11: Restoration Flowchart	37
Fig. 3.12: Case 1 Restoration	38
Fig. 3.13: Case 2 Restoration	39
Fig. 3.14: Case 3 Restoration	40
Fig. 3.15: Case 4 Restoration	41
Fig. 3.16: Case 5 Restoration	42
Fig. 3.17: Case 6 Restoration	43
Fig. 3.18: Case 7 Restoration	44
Fig. 3.5: Proposed Algorithm for Elastic Restoration	45
Fig. 3.6: Proposed Algorithm for BWR Elastic Restoration	46
Fig. 3.19: Media Channel Identifier	47
Fig. 3.20: Network Media Channel Identifier	48
Fig. 4.1: NSFNET Simulation Network	52
Fig. 4.1: MC and NMC Creation Algorithm	55
Fig. 4.2: Yen K Shortest Path Algorithm [YEN70]	56
Fig. 4.3: MC and NMC Creation	58
Fig. 5.1: Dedicated Protection Spectral Results	60
Fig. 5.2: Selected Protection Spectral Results	62
Fig. 5.3: Divided Protection Spectral Result	63
Fig. 5.4: Mixed Protection Spectral Results	65
Fig. 5.5: Protection Network Capacity Usage	66
Fig. 5.6: Protection Network Utilization	67
Fig. 5.7: Network Fragmentation	67
Fig. 5.8: Traffic before fiber cut	69
Fig. 5.9: Traffic after fiber cut with no restoration	70

Fig. 5.10: Case 1 Restoration72

Fig. 5.11: Case 2 Restoration73

Fig. 5.12: Case 3 Restoration75

Fig. 5.13: Case 4 Restoration76

Fig. 5.14: Case 5 Restoration78

Fig. 5.15: Case 6 Restoration80

Fig. 5.16: Case 7 Restoration81

Fig. 5.17: Total MCs Restored82

Fig. 5.18: Total NMCs Restored.....83

Fig. 5.19: Total NMCs Restored with CoS Breakdown.....84

Fig. 5.20: Total MCs Restored with CoS Breakdown84

Fig. 5.21: High Priority MCs Restored.....85

Fig. 5.22: High Priority NMCs Restored85

Fig. 5.23: Network Capacity Usage After Restoration86

List of Tables

Table 2.1: Efficiency improvement in EON vs fixed grid spectrum [GER12].....	16
Table 2.2: Summary of Transponder Design Parameters [PET17].....	17
Table 2.3: Modulation Format-Aware before restoration	25
Table 2.4: Modulation Format-Aware after restoration	26

List of Acronyms

AWG	Arrayed Waveguide
BVT	Bandwidth Variable Transponder
BSR	Bandwidth Squeezed Restoration
DWDM	Dense Wavelength Division Multiplexing
EON	Elastic Optical Network
FBGR	Full Bandwidth Guaranteed Recovery
IFFT	Inverse Fast Fourier Transform
LCoS	Liquid-Crystal-on-Silicon
MC	Media Channel
MEMS	Micro-ElectroMechanical System
NMC	Network Media Channel
NMS	Network Management System
O-E-O	Optical-Electrical-Optical
OPS	Optical Protection Switch
OTN	Optical Transport Network
PBGR	Partial Bandwidth Guaranteed Recovery
QoP	Quality of Protection
QoS	Quality of Service
ROADM	Reconfigurable Optical Add Drop Multiplexer
S-BVT	Sliceable Bandwidth Variable Transponder
SDN	Software Defined Network

SLICE Spectrum Sliced Elastic Optical Path Networking

WSS Wavelength Selective Switch

List of Publications

M. Stapleton, K. Maamoun, and H. T. Mouftah, "Proposed Restoration Schemes in Elastic Optical Networks", Submitted to IEEE/OSA Journal of Lightwave Technology: Special Issue on Photonic Networks and Devices.

M. Stapleton, K. Maamoun, and H. T. Mouftah. "Implementing CoS in EON Protection and Restoration Schemes to Preserve Network Resources," 2018 20th International Conference on Transparent Optical Networks (ICTON), Romania, 2018, pp. 1-4.

M. Stapleton, K. Maamoun, N. Naas and H. T. Mouftah, "Proposed Protection Schemes to Preserve Elastic Optical Network Resources," 2018 Photonics North (PN), Montreal, QC, 2018, pp. 1-1.

Chapter 1. Introduction

1.1 Background

Optical Transport Networks (OTNs) are essential to transmit high data rates over long distances. IP traffic has been growing over the past decade at an enormous rate [LAN12]. The increasing content delivery networks and video on demand has accelerated the bandwidth requirements on optical transport networks [AIB16]. These increasing demands have motivated network operators to increase network capacity by offering an elastic approach to optical backbone networks. Elastic optical networks (EONs) offer a higher capacity by enabling a dynamic sharing of resources, adapting to different data rates, and utilizing flexgrid technologies [LAY13].

EONs have been an erupting and significant research area in the past few years. They provide higher flexibility and spectrum efficiency than the fixed grid network predecessors [CAS12]. The fixed grid network utilizes dense wavelength division multiplexing [DWDM] to enable optical signal carriers to transmit multiple signals on one fiber [LOP16]. The optical signal carriers, or channels, are equally spaced across the C-band spectrum, usually in 50GHz spacing.

The flexgrid spectrum is divided into a finer granularity of 12.5GHz slot widths than the fixed grid spectrum of 50GHz [VEL13] to accommodate elastic traffic requirements. Technology advancements in bandwidth variable transponders [BVTs], flexible optical cross connects, and the flexgrid spectrum have enabled the implementation of EONs [TAK09].

The increased flexibility in EONs employs the concept of Network Media Channel (NMC) and Media Channel (MC) comprise a multiple number of optical carriers, varying in frequency slots

and transmission modulations. The MC traverse the same source to destination paths, enabling the NMCs to reduce guard-bands between them since they traverse the same optical filtering [PED17]. This increases spectral efficiency and allows the MCs, comprising multiple NMCs, to be controlled as single entity.

OTNs carry a significant amount of bandwidth and thus must be survivable and resilient to failures. Protection and restoration schemes are widely used in OTNs to ensure high quality traffic is not affected over a link failure. EONs offer a unique opportunity to extend these survivability techniques using its flexibility and granularity. Research in this field has been fairly studied, specifically that related to sliceable bandwidth variable transponders (S-BVT) [NAP15]. Utilizing the S-BVTs to implement protection and restoration at slice granularity is important as super-channels become increasingly important. However, there has not been significant research into protecting and restoring MCs and NMCs. This thesis aims to explore and propose extended protection and restoration schemes at both MC and NMC levels.

1.2 Motivation

EONs have been rapidly developed and require better thought out protection and restoration techniques to utilize its benefits. While S-BVT protection and restoration has been widely explored, there is a lack of research into protection and restoration in the MC and NMC levels. This gap in the research area discourages the spectral efficiency gained by concatenating NMCs into single entities.

1.3 Objectives

EONs have been an important area of research in the past few years. The objective of this thesis is to provide updated protection and restoration schemes that are extended to utilize the benefits of EONs. This thesis will examine the proposed schemes through simulation on the

NSFNET network. The simulation will provide a proof of concept that these survivability techniques can be applied in real world applications.

1.4 Thesis Contribution

This thesis provides a contribution to the EON research area by proposing various techniques to protect and restore high quality traffic in the event of a single link fault. Through comparisons of fixed grid techniques to various proposed techniques, the advantages to a parent-child MC/NMC hierarchy are illustrated and explored.

1.5 Thesis Outline

This section will provide an outline describing the contents of this thesis and briefly summarizing each chapter.

Chapter 2: “Technical Background and Survey of Technology” provides a review of protection and restoration techniques in DWDM networks. The chapter also examines proposed survivability techniques in EONs. The purpose of this chapter is to provide a basic understanding of the concepts and technologies that enable survivable EONs.

Chapter 3: “System Design” describes a detailed strategy to extend protection and restoration techniques to EONs. This chapter details an algorithm for protection and a corresponding practical architecture. A complimentary restoration algorithm is also proposed. Novel MC and NMC identifiers are also introduced for application.

Chapter 4: “Performance Evaluation” provides the parameters and detailed information used to simulate the schemes previously proposed. The simulation network and assumptions will be explained in depth.

Introduction

Chapter 5: “Results” presents the results obtained from simulation. The results are then analyzed and compared.

Chapter 6: “Conclusion” is the final chapter of this thesis. This chapter describes the contributions of this thesis to the research community and examines future research opportunities.

Chapter 2. Background and Technology Survey

2.1 Introduction

In the following chapter, a background of related work will be discussed. Recently proposed techniques to achieve survivability in both fixed grid and flexgrid networks are analyzed. The related work is divided into the following sections; protection and restoration techniques in fixed grid networks, EONs and the supporting technology, and a survey of recently proposed survivability schemes in flexgrid networks. This chapter aims to provide an overview of necessary technologies in the field and analyze relevant protection and restoration techniques.

2.2 Protection and Restoration in Fixed Grid Networks

Survivability in the optical networks is achieved by using protection and restoration schemes. Optical Mesh Networks are now much more feasible with the advancement in technologies that improve optical reach. The requirement for Optical-Electrical-Optical (O-E-O) regenerators are reduced, encouraging survivable mesh networks [ZYS02]. Protection provides a dedicated redundancy but requires allocated backup resources since the backup resources are pre-planned. Restoration may be pre-planned or dynamic but require the connection to be setup after a fault occurs [VAS04]. Restoration does not require dedicated resources (dynamic) but also does not guarantee recovery. Recovery at the optical layer is crucial as many of the faults occur at the optical layer. Therefore, recovery in the optical domain is faster and more manageable than at the client layer [VAS04]. Network operators must decide on a trade-off between protection and restoration schemes by what is necessary for their type of traffic. The following chapter will

explore the various implementations of protection and restoration. For simplicity, it is assumed that only single point of failure will be considered for the duration of this thesis.

The following Fig. 2.1 illustrates an overview for current techniques for survivability in optical networks. While each predesigned protection has a useful scenario, for this thesis, only optical layer mesh path protection will be considered. Dynamic restoration techniques will also be analyzed in detail.

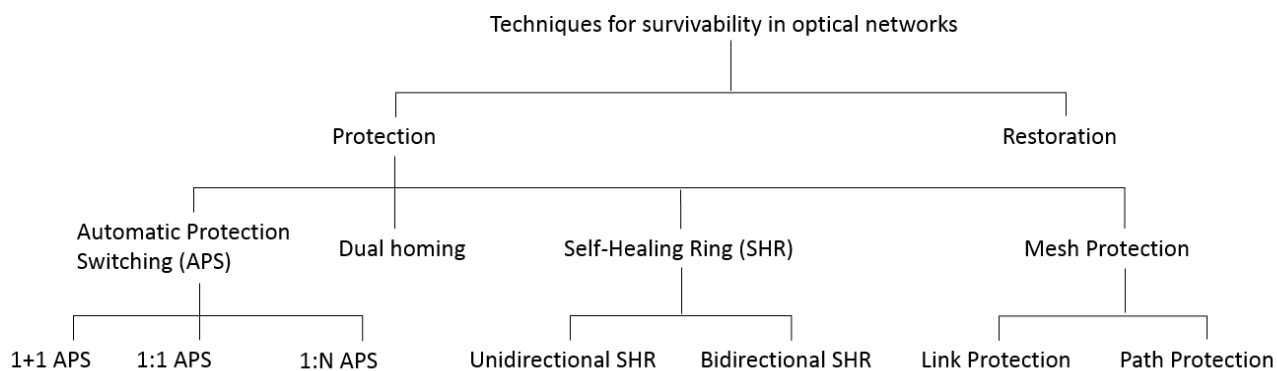

Fig. 2.1: Overview of Survivability Techniques in Optical Networks [2]

Predesign protection relies on recovery from failure based on pre-planned and allocated resources [ZHO00]. Optical layer protection is essential to optical transport networks. Dense wavelength division multiplexing (DWDM) networks combine different wavelength channels, each carrying optical signals, to increase per fiber capacity [SHA14]. In DWDM networks, where several wavelengths of traffic occupy a single fiber, a fiber fault would normally recover the wavelengths on that path. By comparison the client layer would individually restore each traffic stream, resulting in a more complex and slower restoration. The network management system (NMS) is also flooded with alarms during a fiber cut, where the optical layer would have less entities to restore. While optical layer protection is necessary to OTNs, it also has limitations. The optical layer is limited to protection in units of light path, protecting other dimensions of the traffic would require

client layer protection. The optical layer can also not detect all failures, such as a client terminal failure [RAM10]

The below Fig. 2.2 demonstrates the varying architectures of protection, which are illustrated for a point to point automatic protection switching scenario. They can also be applied to the optical WDM networks, which the optical layer protection is concerned with [ZHE04].

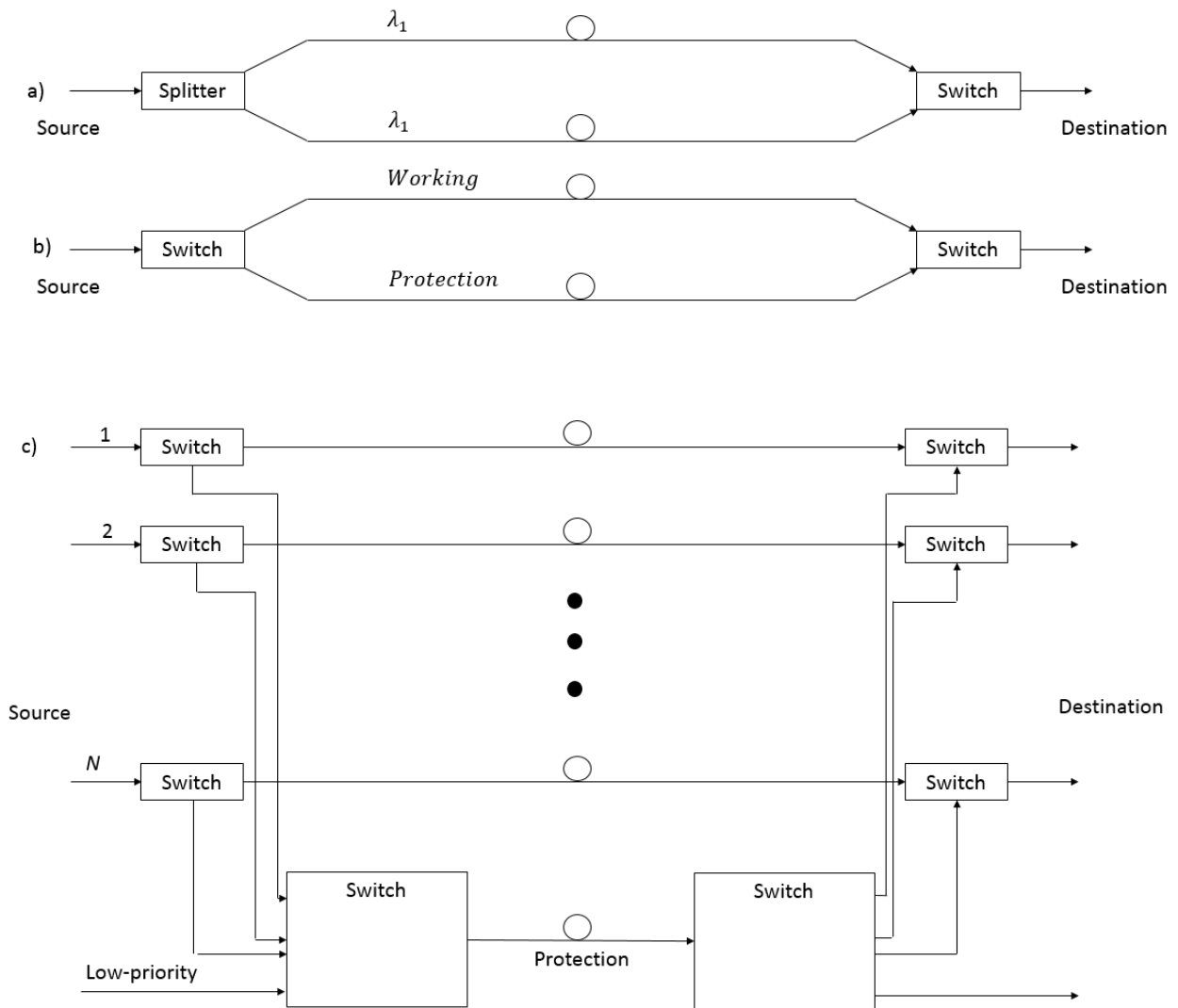

Fig. 2.2: a) 1+1 Protection, b) 1:1 Protection, c) 1:N Protection [RAM10]

System Design

There are three types of optical layer path protection; 1+1 protection, 1:1 protection, and 1:N (or shared protection) [ZHE04, SIM16, SAI13]:

1+1 Dedicated Protection (Fig. 2.2a): The working and backup path are actively carrying source to destination connections. The paths are equipped with switching equipment, to quickly select the required traffic path. The working and protection paths are usually link disjoint from the source to destination. In the event of a failure, the receiver switches to the protection path. 1+1 is fast recovery, however the splitter adds a 3dB loss to the signal at the transmitter.

1:1 Protection (Fig. 2.2b): The working path is the only path carrying the transmitted signal. In the event of a failure, the transmitted signal is switched to the protection path. While 1+1 protection has a quicker resolution than 1:1 protection, it requires more equipment to implement. 1+1 protection also requires the backup path to occupy the entire reserved capacity. In a 1:1 protection scheme, the backup path may be utilized for lower priority traffic which is consequently dropped in the event of a failure.

1:N Shared protection (Fig. 2.2c): Similar to 1+1 protection, however the protection path is shared among “N” multiple paths. Shared protection requires significantly less resources, but does not guarantee traffic. In this protection, there may be multiple working paths, protected by less protection paths. Due to this configuration, it is worth noting that working paths must have diverse paths from one another.

The below diagram shows an example of shared protection with a 2:2 ratio (Fig. 2.3 a) and a 2:1 ratio (Fig. 2.3 b).

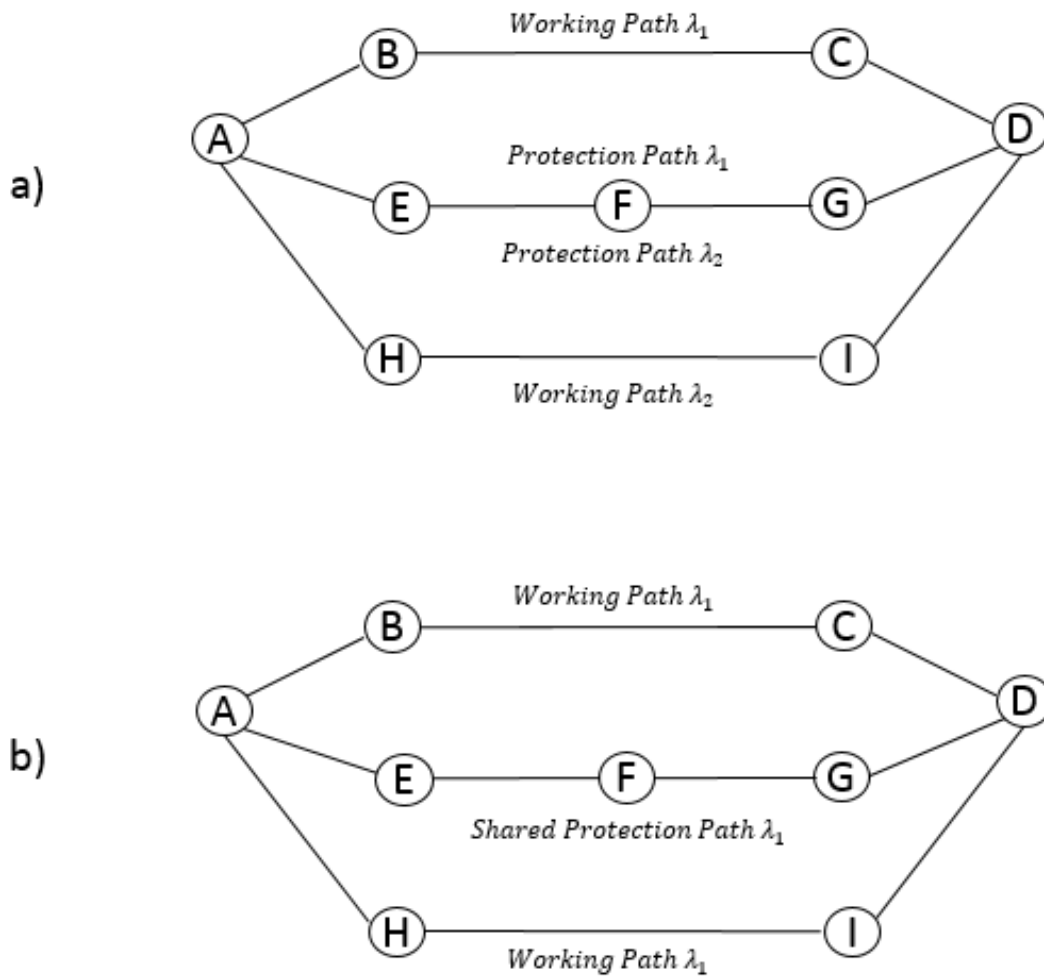

Fig. 2.3: Shared Protection Path Examples [SIM16]

As seen in the above Fig. 2.3, shared protection is ideal in a single point failure. However, if multiple working paths fail, then the affected working paths do not have available resources to protect. This results in working path traffic being dropped.

Two types of implementations are available for the protection schemes discussed earlier; client side and network side protection [SIM16]. Client-side protection delivers the working and protection signals, either by duplicating the client signal from the IP router (Fig. 2.4a) or using a

splitter to duplicate the client signal (Fig. 2.4b). In network side protection (Fig. 2.4c) the optical layer switch multicasts the signal to both working and protection paths, or the optical layer switch selects switches at the time of failure. Client-side protection requires a transponder for each working and protection path, where network side protection does not. To implement the proposed protection scheme for EONs, client-side protection is required to support selected, divided, or mixed protection. This is a requirement because the entire path is not necessarily switched. If a NMC is dropped from an MC, this would require the ability to drop that correlating transponder from the signal. The optical protection layer switch may be used in the dedicated protection scenario, where all of the traffic is switched.

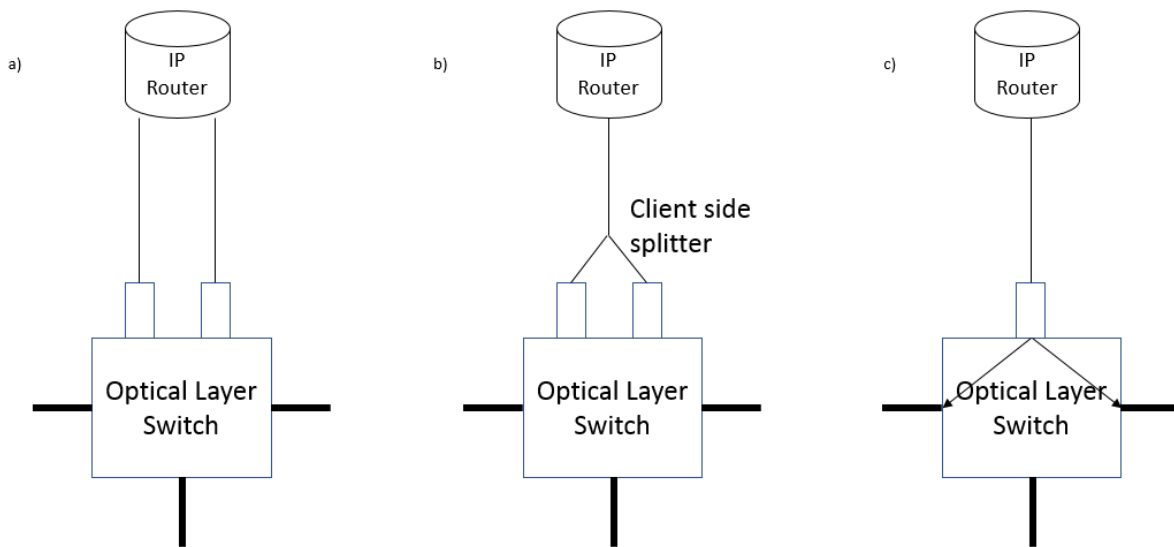

Fig. 2.4: Protection Architectures [SIM16]

The introduction of EONs and Software Defined Networks (SDN) are pushing optical transport networks to be highly configurable. In a configurable network, dynamic optical networking is essential. Dynamic optical networking allows connections to be rapidly torn down and created without any operational or equipment reconfiguration involvement [SIM16]

The below Fig. 2.5 demonstrates the various types of restoration architectures in WDM optical networks. Similar to protection schemes, there are many types of restorations available, which are beneficial to utilize depending on the type of traffic and network.

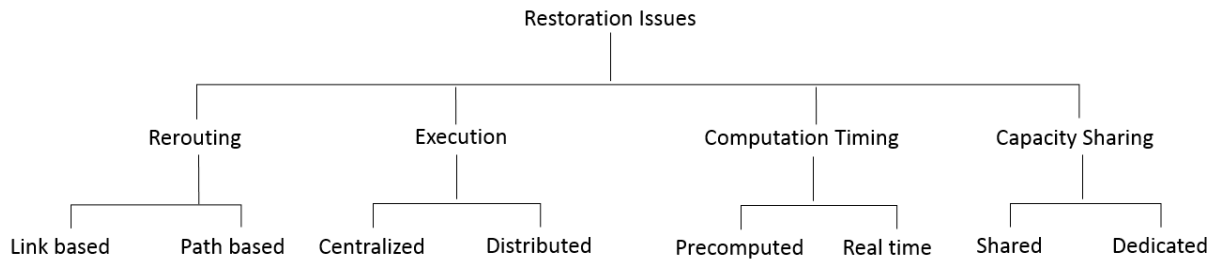

Fig. 2.5: Restoration Types [SOM06]

The rerouting method can be either link-based or path-based. In a link-based rerouting architecture, the backup path is rerouted around the failed link. A path-based architecture, reroutes the entire path from source to destination [SOM06]. A path-based rerouting scheme would be preferable in an elastic optical network, since the entire path is rerouted from source to destination. In a link-based rerouting, the wavelength or frequency would not be able to be retuned due to the preserved working links. Link based rerouting would also introduce challenges when a media channel, described later in this chapter, would need to be modified to recover traffic.

The type of execution control depends on the type and size of the network. Distributed control is the preferred method in larger networks, since it requires messages to be exchanged between nodes [SOM06]. The computations for routing and provisioning are done at each node in a distributed manner, alleviating the computation that a centralized method would impose [SAI13].

Computation time determines whether the recovery path is precomputed before a failure occurs or computed in real time. Obviously, the precomputed method offers a faster recovery but also requires constant exchange of messages to update current information. Both computation

methods would be beneficial in EONs, and the trade-off between the two depends on the priority of the traffic.

Capacity sharing is like protection, in that capacity can be reserved in a dedicated model, or reserved backup capacity that is shared among several working paths. This is also known as primary and backup multiplexing [SAI13], where primary multiplexing would indicate a reserved wavelength for the working path, and backup multiplexing shares a reserved wavelength between multiple working wavelengths. The latter assumes only a single fault scenario, and that the reserved backup wavelength has link disjoint paths between backup paths. This is another parameter available to the network operator that is a trade-off between guaranteed recovery and cost to reserve network capacity.

A class of service is applied to traffic based on the type of protection or restoration scheme [RAM10]. For example, the highest service class would use a 1+1 protection scheme. Where the traffic protection is guaranteed and has the fastest restoration time. The next highest service class, may use a 1:1 protection scheme or 1:N shared protection scheme. The protection is not guaranteed but there are pre-allocated resources reserved for protection and the recovery time is fast. The next service class, would be a form of best effort traffic. A backup path will be computed or pre-computed by the path computation engine and the working path would be restored at the time of failure. This is the slowest recovery time and the restoration depends on the availability of resources in the network. Low priority traffic would be unprotected traffic, which is dropped when the working path is faulted. Lastly, the lowest priority and lowest availability traffic may be dropped when a higher service class working path, requires the resources available on the protection path.

As discussed through the last section, there are many types of protection and restoration schemes at various layers of the network. This encourages network operators to customize

different types of traffic to corresponding survivability techniques, to offer resilient and efficient optical networks.

2.3 Elastic Optical Networks and Supporting Technology

The following section will describe the supporting technology that facilitate EONs. The main technologies to attain EONs are flexgrid spectrum, bit-rate variable transponders (BVT), and flexible Wavelength Selective Switches (WSS). A flexible network is necessary to address the challenges imposed from large content providers, new data centers, and peering relationships to adapt to actual traffic needs [[ITU-T12].

EONs are defined by two key components [[ITU-T12]:

1. Optical spectrum can be divided up flexibly
2. Transceivers can generate elastic optical paths with variable bit rate

1 is achieved through flexible Reconfigurable Optical Add Drop Multiplexer (ROADM) architecture and a flexible spectrum, while 2 is realized through the advancement of BVTs.

In Dense Wavelength Division Multiplexing (DWDM) networks, the past implementations have been on a fixed grid implementation. As defined in [[ITU-T12], the fixed grid currently supports a fixed channel spacing of 12.5GHz to ~100GHz. Fixed grid DWDM networks would contain all optical DWDM channels of the same size, either 50 or 100GHz [CLO16]

The flexible grid requires a MC and NMC. A MC is a media association that represents both the topology and the resource that it occupies, which is the path through the media and the frequency slot it occupies. The nominal central frequency and slot width of a MC in a flexgrid optical network are described as:

$193.1 + n \times 0.00625$ where n is a positive or negative integer including 0 and 0.00625 is the nominal central frequency granularity in THz and a slot width defined by:

$12.5 \times m$ where m is a positive integer and 12.5 is the slot width granularity in GHz [[ITU-T12]

The size of a MC is determined by the frequency slot width it occupies. A MC may carry more than one OCh-P signal or NMC.

The MC is the concatenation of all the media elements between a source and destination, illustrated in Fig. 2.6. NMCs can be spaced closer together since they are travelling from the same source to destination [GON15]. The spacing needed between NMCs are referred to as guardbands [GER12]. Fig. 2.6 illustrates an example of a MC containing two NMCs. The NMCs are spectrally adjacent, contained within the MC.

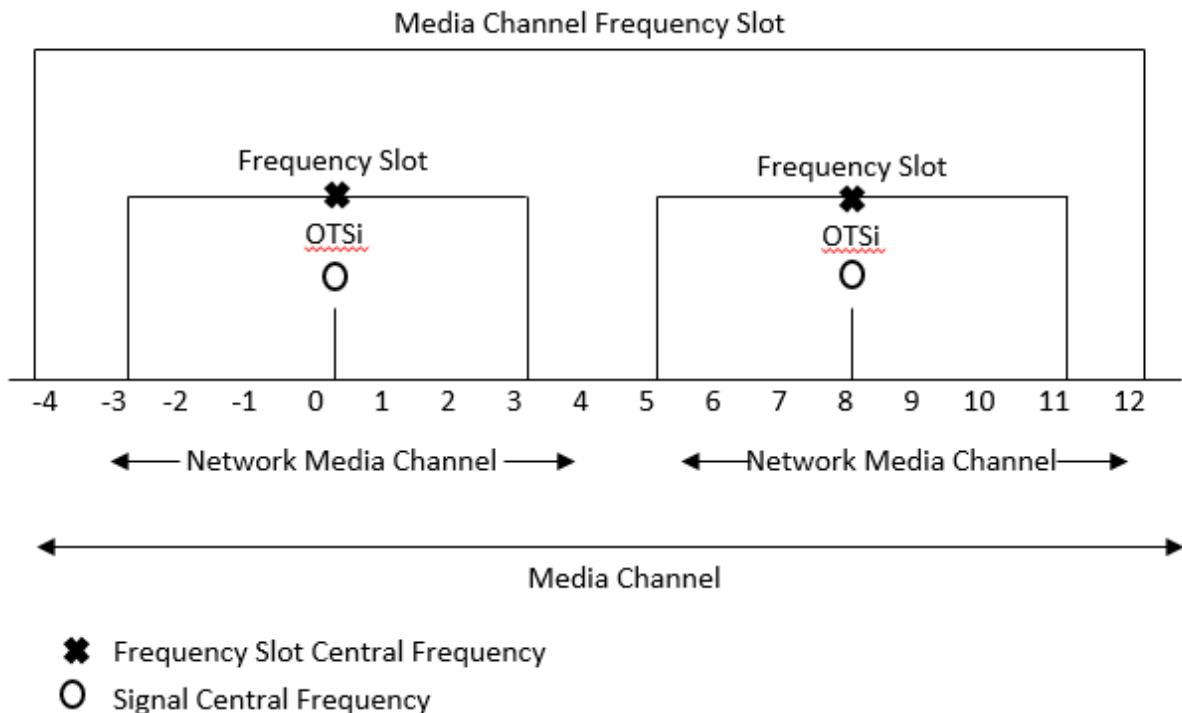

Fig. 2.6: Composition of a Media Channel [GON15]

For simplicity, we will discuss the most common fixed grid spacing, 50GHz, when comparing to flexgrid implementations. As seen in the below Fig. 2.7a, all channel spacing is rigid and equal. In this implementation, the immobility of channel spacing is not spectrally efficient. For example, depending on the bit rate of the channel, not all channels are equivalent in the amount of spectrum they consume. Flexible DWDM grid was defined to alleviate this problem. With the introduction of flexgrid, channel spacing can now be more spectrally efficient. Fig 2.7b illustrates the use of channels with various widths, including channels greater than 400Gbps, with flexgrid spacing against the previous fixed grid slots.

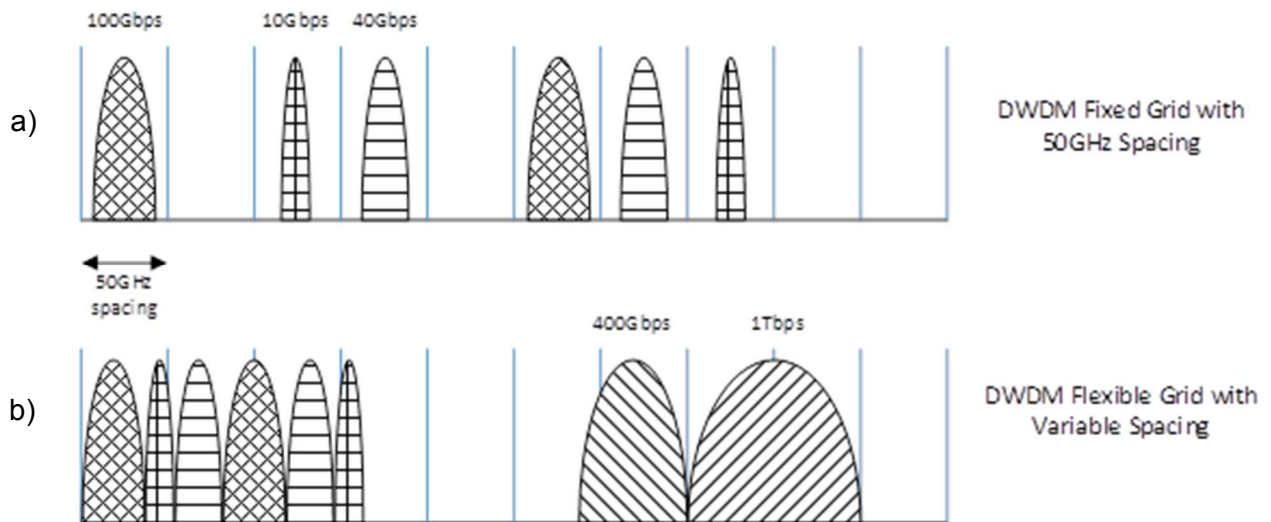

Fig. 2.7: Fixed Grid vs Flexible Grid Spacing

To exhibit the spectral advantages Table 2.1 demonstrates an excellent view of the efficiency increase for each data rate in an elastic optical network. The table compares channel bandwidths of common modulation formats, assuming a 10GHz guardband for flexgrid channels, and 50GHz channels for a fixed grid implementation.

Table 2.1: Efficiency improvement in EON vs fixed grid spectrum [GER12]

Demand bit rate (Gb/s)	Modulation Format	Channel BW (GHz)	Fixed Grid	Efficiency increase in EON
40	DP-QPSK	25+10	1 50GHz Channel	35GHz vs 50GHz = 43%
100	DP-QPSK	37.5+10	1 50GHz Channel	47.5GHz vs 50GHz = 5%
100	DP-16QAM	25+10	1 50GHz Channel	35GHz vs 50GHz = 43%
400	DP-QPSK	75+10	4*100Gbps in 4*50GHz Channel	85GHz vs 200GHz = 135%
400	DP-16QAM	75+10	2*200Gbps in 2*50GHz Channel	85GHz vs 100GHz = 17%
1000	DP-QPSK	190+10	10*100Gbps in 10*50GHz Channel	200GHz vs 500GHz = 150%
1000	DP-16QAM	190+10	5*200Gbps in 5*50GHz Channel	200GHz vs 250GHz = 25%

The EON is more spectrally efficient in every scenario above, further showing that the flexgrid is superior to a fixed grid implementation. The 400Gb/s and higher require a superchannel, implemented through BVTs.

[SAM15] describes a new generation of sliceable bandwidth variable transponders. The BVTs are able to dynamically tune by adjusting its parameters such as baud rate, modulation format, number of subcarriers which serve varying capacity and reach requirements [IMR18]. Subcarriers are single optical carriers that are multiplexed together to increase the capacity of an optical channel.

To achieve these subcarriers, there are various implementations and technologies. A few of them are described below: [GER12]:

- Coherent Optical OFDM (Orthogonal frequency division multiplexing) each modulator generates a low speed subcarrier using inverse fast fourier transform
- Coherent Wavelength Division Multiplexing – several subcarriers, subcarrier rate is equal to subcarrier frequency spacing
- Nyquist Wavelength Division Multiplexing – minimizes spectral bandwidth between channels generated from independent laser. Spectral shaping with optical prefiltering.

- Optical Arbitrary Waveform Generation - each channel can be in a different modulation format. Coherent combination of many spectral slices.
- Optical Frequency Combs - equally spaced discrete spectral lines. The transponder is a single semiconductor, which provides multiple frequencies [IMR18]

The variety of transponder technology, offers an abundance of design parameters. The following Table 2.2 provides a summary for the various design parameters for a transponder:

Table 2.2: Summary of Transponder Design Parameters [PET17]

Network Grid Design	Laser Type	Optical Carrier	Programmable Features	Performance
Fixed Grid	Non-tunable	Single-carrier	Modulation format	Fixed capacity
Flexible Grid	Tunable	Multi-carrier	Symbol rate Wavelength channels Spectral slots Optical carriers Electrical carriers	Flexible channels Flexible bitrates Flexible grid on different center frequencies Bitrate granularity Superchannels Multiple optical flows(sliceable)

Finally, the wavelength selective switches (WSS) allow EONs to be practically feasible. Fixed grid WSS were not flexible due to their arrayed waveguide (AWG) and micro-electromechanical system (MEMS) technologies. These technologies did not allow variable passband widths, therefore supporting only fixed grid channel granularity. Recently developed Liquid-Crystal-On-Silicon (LCoS) technology uses a holographic principle that allows variable channel widths, while routing and switching wavelengths [LOR16]. This technology supports channels at a 12.5GHz granularity [PET17] while also supporting wide band superchannels. Each optical channel is then switched independently using an array of pixels [HAR06]

The advantages to implementing an elastic optical network outweigh the challenges imposed. The grouping of connections, in a media channel, allow the connections to be managed as a group. Grouping encourages simplified management of the connection, reducing the total number of managed connections. As discussed earlier, the flexgrid architecture is more spectrally efficient than its fixed grid predecessor [VEL12]. The fixed grid architecture is also unable to accommodate high bit rate connections (<400gbps). Finally, BVTs provide the flexibility to adapt to the channel condition so that a robustness modulation format with the correct number of subcarriers is utilized [MOR13]. BVT technologies allows the user to provision based on a trade off between reach and spectral efficiency in order to optimize their network. [MAR15]

2.4 Proposed Survivability Schemes in Elastic Optical Networks

The following section reviews related work in the field that addresses survivability in elastic optical networks. Many of the related works in survivability have stemmed from the idea of spectrum-efficient and scalable elastic optical path networking (SLICE). The SLICE architecture and concept will be described, followed by an evaluation of the methods of protection that rely on the SLICE architecture, such as bandwidth squeezed restoration.

Spectrum-sliced elastic optical path network, or SLICE [JIN09], was an early proposed architecture for the evolving elastic optical networks. The following Fig. 2.8 illustrates the transition to flexible grid spectrum from its predecessor fixed grid utilizing the SLICE architecture.

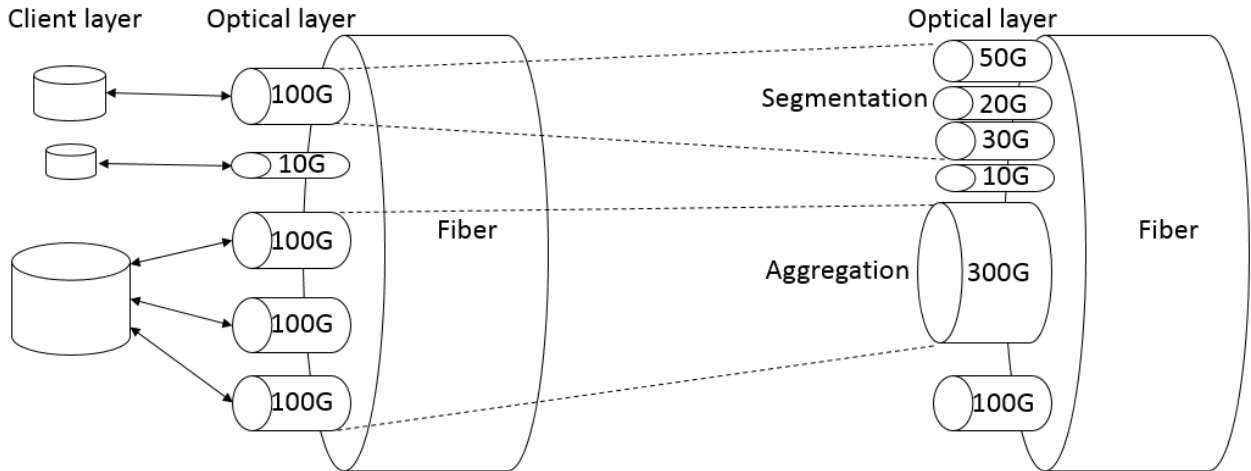

Fig. 2.8: SLICE Architecture [JIN09]

As seen in the above Fig. 2.8, there are 3 key functionalities of SLICE architecture; subwavelengths, super-wavelengths, and heterogenous data rates. The subwavelengths are segmented wavelengths that were previously multiplexed in the electrical layer. The super-wavelengths are aggregated traffic, carried over one large optical channel. The heterogenous data rates, are multiple rates such as 10Gbps, 50Gbps, 300Gbps which can co-exist on the same flexible spectrum. SLICE aims to alleviate possible fragmentation issues while efficiently utilizing the spectrum in a mesh optical network [JIN09]. The optical spectrum is contiguously concatenated using custom bandwidth sized channels. The SLICE channels are expanded and contracted to meet the user requirements. This means that the channels must be contiguous, continuous, and have the same end-to-end optical path. Utilizing technology such as bandwidth variable transponders and granular wavelength selective switches, cross-connections that only accommodate the necessary bandwidth are created. Super-channels, discussed earlier, are also supported along the path, assuming the transponders are capable. The SLICE network also aims to support multi data rates, since the flexgrid spectrum is utilized. This SLICE architecture is the obvious next step to the evolving technologies; bandwidth variable transponders, bandwidth

variable wavelength selective switches, and the flexgrid spectrum. The protection and restoration techniques are not fully explored in this architecture. The authors in [JIN09] briefly suggests a bandwidth squeezed restoration technique, where the bandwidth would be reduced to accommodate a recovery where all of the required spectrum capacity is not available. The advantages and disadvantages of this architecture to the survivability of the network are not sufficiently considered. Firstly, the opportunity to implement a working or protection channel solely based on bandwidth requirement is a major advantage. The network operator may efficiently allocate backup resources for only high priority traffic, while freeing up spectral resources. The implications of this is that the network becomes susceptible to fragmentation. Traffic that is not carefully protected or restored, may be spectrally efficient if the new connections created leave unusable spectrum slots. There is no solution offered to traffic priority in [JIN09]. Since some traffic may be higher priority than others, a priority or class of service should be created to ensure unnecessary traffic protection and restoration resources are not utilized. Finally, to implement survivability schemes in this architecture, a new protocol is required to ensure coordination during a fault.

The references [GOS15, SON11, CAS14] offer an extension of the bandwidth squeezed protection and restoration in SLICE network, described below. The protection and restoration schemes aim to restore only mission critical traffic by taking advantage of bandwidth variable transponders to squeeze the bandwidth in the instance of a fault. The following Fig. 2.9 illustrates this concept. The working path in this example is carrying 320 Gbps of traffic. When the line is faulted the traffic cannot be restored, since there is only sufficient bandwidth for 280 Gbps. To restore the traffic, the bandwidth is reduced to 120 Gbps higher quality service and successfully restored to the protection path.

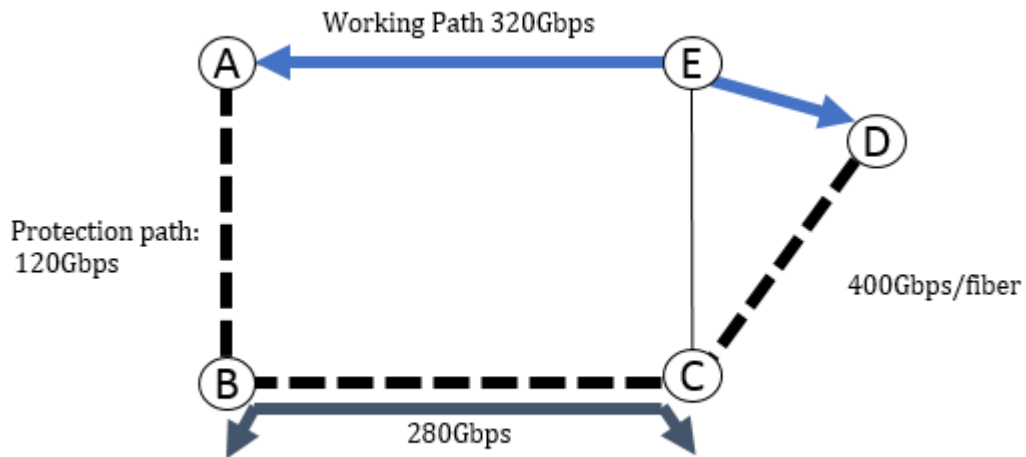

Fig. 2.9: Bandwidth squeezed restoration [SON11]

To implement a resource efficient recovery scheme, the traffic has an associated quality of service (QoS) or quality of protection (QoP). This ensures that mission critical traffic will be recovered in the instance of a fault, while less critical traffic be treated as best effort. The previously discussed technology increases the granularity of the channel and allows the channel to be separated in slices. Each slice is having its own assigned QoP. The bandwidth variable transponder utilizes OFDM modulation techniques to separate the traffic into slices. The bandwidth is reduced or squeezed by dropping the spectrum slices.

The traffic is segregated into the following classes: red, yellow, and green. Traffic with a red identification is dropped immediately in the event of a fault. Yellow traffic is treated as best effort and only restored if sufficient bandwidth is present. Green is the highest priority traffic and requires dedicated spectrum on the backup path to ensure recovery. Segregating traffic into various levels of protection relieves the excess bandwidth resources that would have otherwise had to have been reserved for the bandwidth of the entire path.

The above traffic policing offers three types of recovery functions in the proposed bandwidth squeezed restoration (BSR); full bandwidth guaranteed recovery (FBGR), partial bandwidth guaranteed recovery (PBGR), and best-effort recovery. FBGR allocates the total amount of working path bandwidth to the protection bandwidth, like the already used shared backup protection scheme. PBGR allocated a partial amount of bandwidth of the working path to the protection path. In these two instances the backup resources are pre-reserved. Best effort recovery backup path uses the available resources in the backup path, until the backup path resources are filled. Note that backup resources are not pre-reserved in the case of best effort recovery.

The technique offered in [SON11] takes advantage of the architecture in [JIN09] to offer a finer granularity to the user regarding channel provisioning and survivability. This scheme requires coordination between the optical layer and higher service layers. A multilayer approach is much more complex in nature. Due to the messaging required between layers, this is a slower restoration approach than an optical protection switch or restoration, which also requires a further development of protocols. This scheme also only considers restoration on a per transponder basis and does not consider the system as a whole [SON11] fails to address the growing concern with spectrum fragmentation. While BSR may reduce the in-service spectrum, the implications of reducing channels are not considered. For example, consider a BVT spectrally contiguous to another channel on the backup path. During BSR, if the spectrum between the BVT and the next adjacent channel is not adequate to provision another channel, then there is a fragment of unusable spectrum. In this instance the spectrum available for provisioning is not better than if the entire BVT had been restored. Fragmentation impairs the network and results in high blocking probabilities and inefficient spectrum usage [JU15]

The [TAN15] follows a similar idea of subcarrier modules but suggests having backup modules in the case of a transponder failure, referring to it as subcarrier restoration (below Fig. 2.10).

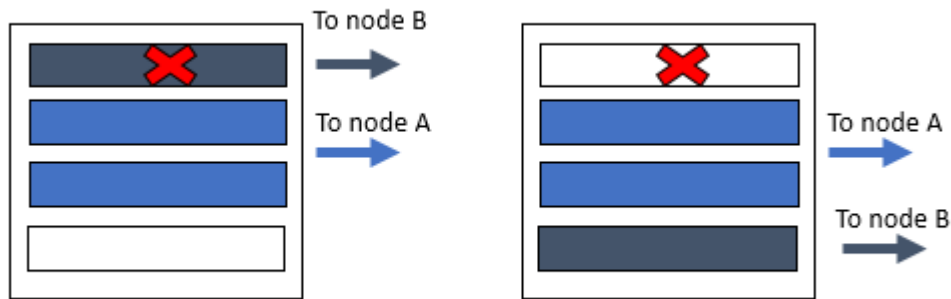

Fig. 2.10: Subcarrier Module Restoration [TAN15]

This method would increase the cost and the complexity of bandwidth variable transponders. In the event of a subcarrier module failure, it would likely take much longer to retune the transponder to utilize a backup subcarrier module than it would to use an optical protection switch (OPS), to quickly switch to a backup transponder. If the traffic was high priority, it is likely there would be a backup transponder anyways in the instance of a transponder failure.

In [LAY18] a protection that offers an associated quality of service (QoS) by utilizing BVTs is proposed. They offer two architectures to implement a 1+1 dedicated protection scheme in flexgrid, below Fig. 2.11. In each scenario the transponders are equipped with dual lasers that allow each frequency to be modulated differently. The protection path drops the low priority traffic when under a fault. To achieve the QoS, the traffic is pre-segmented into two qualities of service; premium and best effort, at the client layer. Since there are two lasers through an optical switch, the recovery time is fast. In the first scenario, a single wavelength is sent through the working path. In the second scenario, a wavelength is sent on both the working and protection path, but only modulated on the working path.

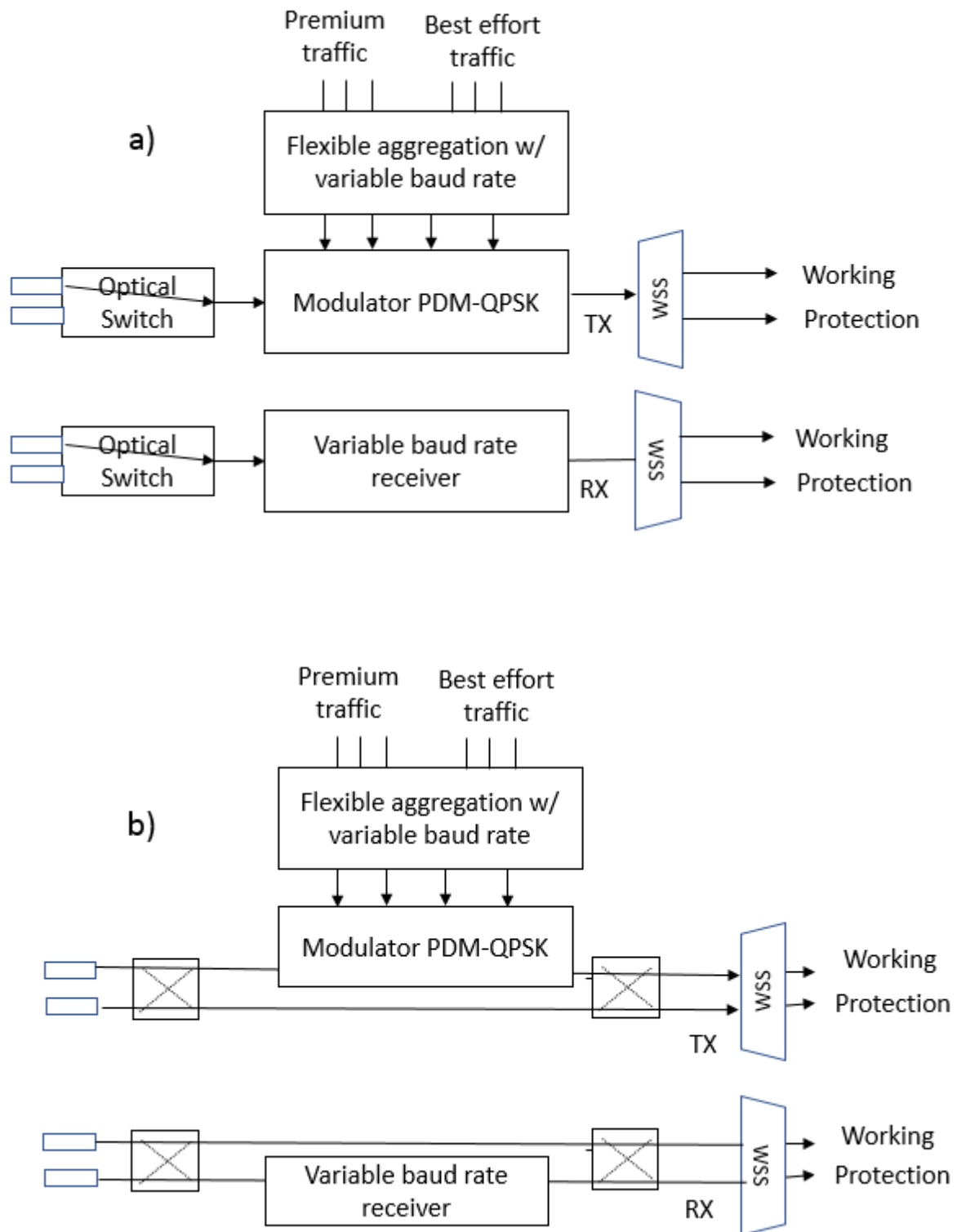

Fig. 2.11: Dedicated protection schemes [LAY18]; a) Single wavelength on working path, b) Wavelength on both working and protection path

Another interesting theoretical technique is signal overlap, proposed in [A23-A24], where the same central frequencies along an optical path overlap through superposition of the signals. The authors in [CUG17] took this concept further and suggested a dedicated protection scheme. This protection scheme implements 2 working channels along the same path with the spectral overlap. There corresponding protection path also will accommodate the spectral overlapped channels. In theory, this method will produce a higher accepted traffic load. However, the signal overlap theory is complex, and may be difficult to implement in practical applications due to non-linear impairments. The OSNR operating margin, would have to be identical, or very close for the two signals. Since the OSNR link margin relies on a variety of ageing and uniformity effects [MIT13], this is not feasible in practicality.

BVTs are a particularly popular research area due to the flexibility of the modulation format. The BVTs are now able to dynamically tune to various modulation formats according to the traffic bit rate and reach requirements. Reference [VEL17] proposes a modulation format-aware restoration that utilizes S-BVTs. The benefits of the granularity of the slices and the capability of multiple modulation schemes are exploited. An example of modulation format-aware restoration is illustrated below [VEL17].

In Table 2.3, 3 connections are established with S-BVTs with various modulation formats and number of BVT slices.

Table 2.3: Modulation Format-Aware before restoration

Connection	Bitrate (Gbps)	Length (km)	Hops	Modulation Format	No. of Slices
1	200	450	2	DP-QAM16	2
2	400	650	2	DP-QAM16	4
3	300	900	4	DP-QAM8	4

The next Table 2.4, is the corresponding connections from Table 2.3 after restoring from a link fault. In the first connection, the restoration required a longer length in the recovery path than of the working path. To avoid signal degradation due to an extended reach, the modulation format was then reduced, and the number of slices increased in order to sufficiently recover the connection. The second connection, also required a reduction in modulation format to accommodate the extended reach. This connection utilized the bitrate to squeeze and recover the connection. The last connection in Table 2.4, reduced the number of slices and the bitrate to squeeze both to the bandwidth required to restore the connection.

Table 2.4: Modulation Format-Aware after restoration

Connection	Bitrate (Gbps)	Length (km)	Hops	Modulation Format	No. of Slices
1	200	700	2	DP-QAM8	4
2	300	1000	4	DP-QAM8	4
3	100	1100	4	DP-QPSK	2

The modulation-format aware technique is an excellent suggestion to truly utilize the benefits of S-BVTs in EONs. This is still an early research area and due to the complexity of the S-BVTs and the various new parameters observed in EONS, it may prove challenging to implement. For example, if the restored connection was reverted to its home path after the fault was recovered, the connection would ideal be able to dynamically re-tune the slices and modulation format to its original connection. There is also an assumption that all transponders would have the capability of S-BVTs. The control plane would need to recognize which connections have the capability to restore at a slice level and adjust modulation format when determining adequate restoration paths.

SDN is an interesting research area that has promising applications to ease network operations. In paper [PAO14], an interesting amalgamation of both S-BVTs and SDN architecture is proposed to provide restoration in EONs. The work utilized multipath recovery through an SDN

architecture with the S-BVT technology. The results concluded that the SDN OpenFlow computation added around 30-40ms of restoration time. While this is an impressive detection time, it would be beneficial to demonstrate the time in a real-network and determine if this is a scalable solution.

This chapter has discussed a few of the methodologies proposed to increase the survivability in EONs. However, research is still lacking in the area of media and network media channels. MC and NMCs offer a greater granularity as well as the opportunity to group NMCs into MCs. This is an important area of research, as the MCs are much larger than the single optical carriers. This requires a novel approach to survivability to utilize the spectrum efficiently, while protecting and restoring high priority channels.

Chapter 3. System Design

3.1 Introduction

The following chapter describes the design of proposal to extend protection and restoration schemes. As EONs are adopted into the field, the survivability of the networks become an essential design challenge. Current DWDM optical networks survivability schemes may fail if they are deployed in EON that have large MCs with many NMCs due to lack of available spectrum. This applies to either protection and/or restoration schemes that may be deployed in the network.

Both protection and restoration schemes may be deployed at the same time in the network. This allows the NMS at the time of failure to trigger the appropriate survivability scheme. As discussed in Chapter 2, EONs are assembled into MC and NMC, below Fig. 3.1.

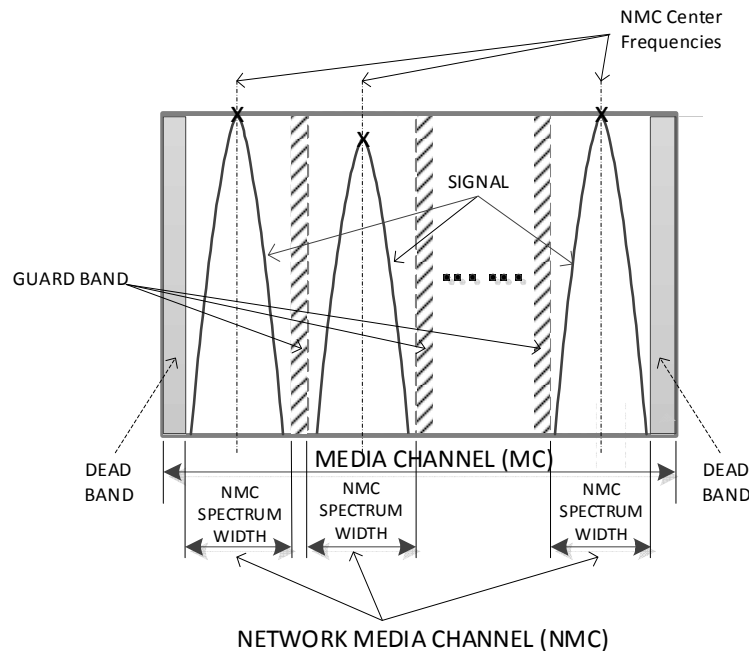

Fig. 3.1: Media and Network Media Channel Representation

NMCs traversing the same source to destination that are contiguous and continuous are compacted into a media channel, reducing the necessary spectral bandwidth between adjacent NMCs.

This provides a unique opportunity to improve the survivability of EON by creating a parent-child hierarchy that applies protection and restoration schemes to both MC and NMC. Through the proposed algorithm for elastic protection and restoration, the spectrum is protected at a finer granularity. Both proposed protection models and restoration algorithms strive for optimal network survivability resource saving.

3.2 Proposed Protection Scheme

The following section describes a novel approach to protection in EONs (EON). This technique aims to extend current implementations to include a finer granularity of protection at the NMC level, while also supporting dedicated and shared protection employments already existent in OTNs. Selected, divided, and mixed protection are newly introduced as a contribution in this thesis. These novel protection schemes will be compared against the already existing dedicated protection.

3.2.1 Protection types

The following scenarios, describe a proposed dedicated and shared protection in EON where the level of protection extends to the NMC level. The NMC represents working channels, where the NMC' represents the protection copy of the working NMC.

1. 1+1 or Dedicated Protection (Fig. 3.2): This type of protection exists in current fixed grid implementation, where all of the media channel has backup resources for protection. Every NMC in the working MC has a copy in the protecting MC with the same spectral occupancy. The center frequencies of the NMCs of both the working and protecting MCs

should align together, to avoid any unnecessary retuning in the event of a fault. The NMCs may be from the same transponders (like multi laser transponders discussed earlier) or from different transponders. There is also no requirement that all of the NMCs are of the same spectral occupancy, meaning that the media channel does not have to be homogeneous.

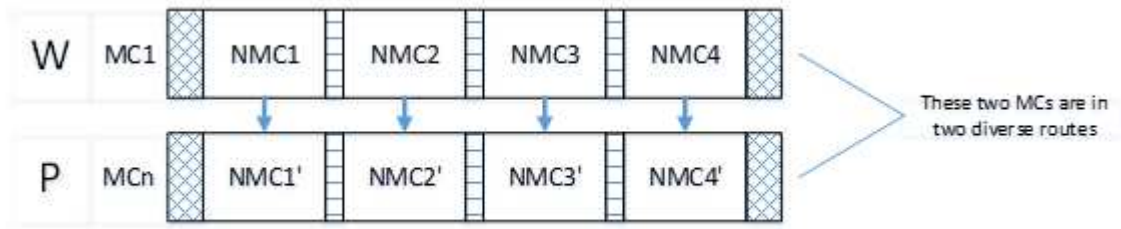

Fig. 3.2: Dedicated Protection in EON

2. M+N or Selected Protection (Fig. 3.3): A selection of NMCs from the working MC has a copy in the protecting MC with the same spectral occupancy. The unprotected NMCs may have less important traffic that does not require protection. To ensure that protection does not introduce many unusable slots, NMCs with higher traffic priorities should be contiguously assigned. This way the media channel may be squeezed into a new media channel, rather than fragmented. An example to that is “Best Effort” IP traffic.

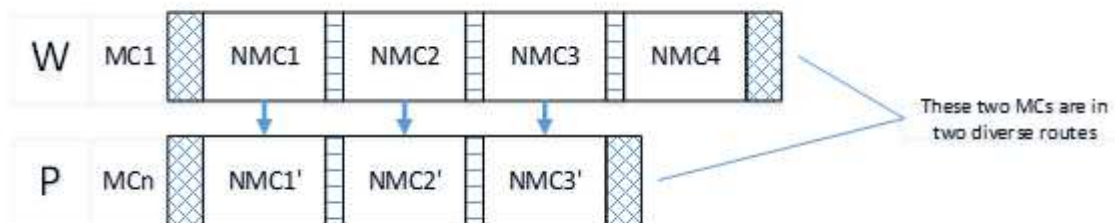

Fig. 3.3: Selected Protection in EONs

3. M+N+O+.. Divided Protection (Fig. 3.4): The protecting copy of the working NMCs are divided into more than one MC and each have the same spectral occupancy. To ensure the protection is successful, the P1 and P2 protection routes must be diverse from the working route and ideally each other. The media channel is essentially split into two or more separate media channels to be protected on route diverse paths.

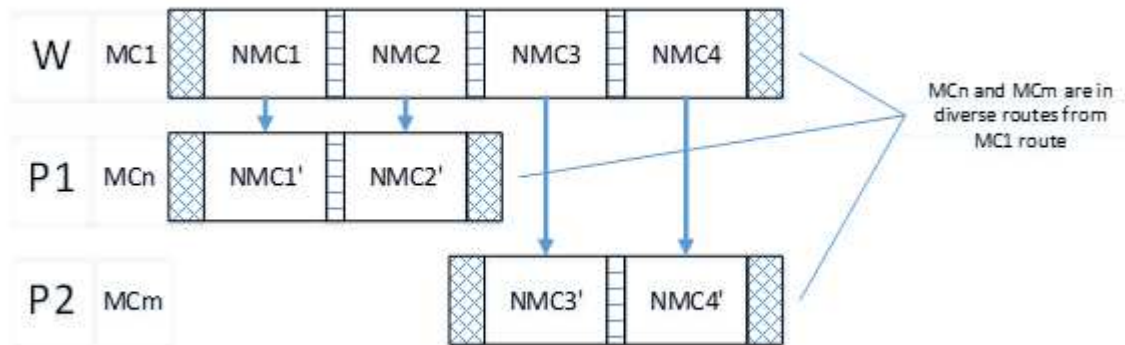

Fig. 3.4: Divided Protection in EONs

4. M,N,O,.. Mixed Protection (Fig. 3.5): Both working and its protecting copy are distributed among several MCs. Mixed protection offers an amalgamation of previously discussed selected and diverse protection. The media channel is separated into multiple media channels and protected over other diverse working routes. The protected network media channels can then form a new media channel with the other working media channels.

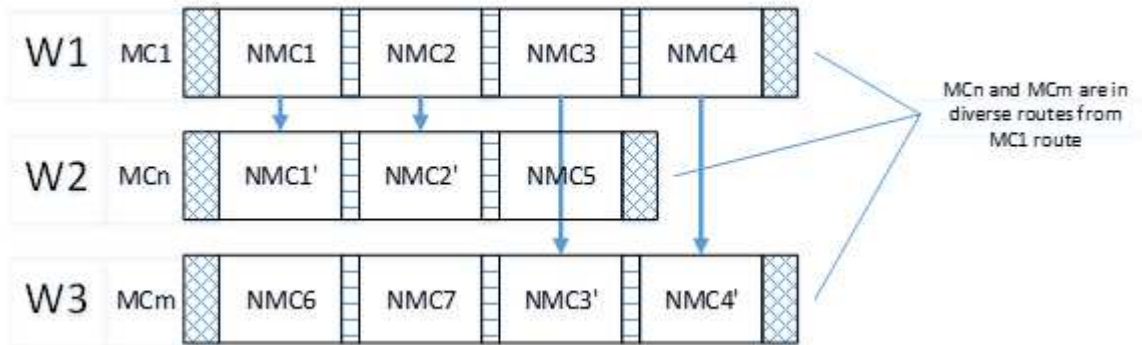

Fig. 3.5: Mixed Protection in EONs

A few assumptions must be noted to ensure correct implementation; working and protecting MCs should be in a diverse route from each other. If NMCs are protected in multiple working paths, as in the mixed protection, all these working paths must be diverse from each other. To avoid potential spectrum fragmentation problems and re-tuning of transponders, the protected NMC allocation must be on the same spectrum as its working counterpart. In the scenarios where new media channels are formed, all of the network media channels within the media channel traverse the same path and have the same source and destination.

3.2.2 Protection Architecture

The following will review current protection infrastructure and propose new architecture to meet the requirements of the previously discussed protection schemes.

The first architecture (Fig. 3.6) represents the dedicated protection scheme with 4 NMCs in a EON. In this example, each NMC has a corresponding transponder for simplicity. The below example illustrates a protected MC, containing 4 NMCS. Since each NMC is protected in the optical domain, each NMC requires an optical protection switch. All of the NMCs go to the same MUX where they traverse the path as one MC. Upon line fault, the NMCs are promptly switched to the protection line. This architecture is inherited from a fixed grid network to support the multiple NMCs in a EON.

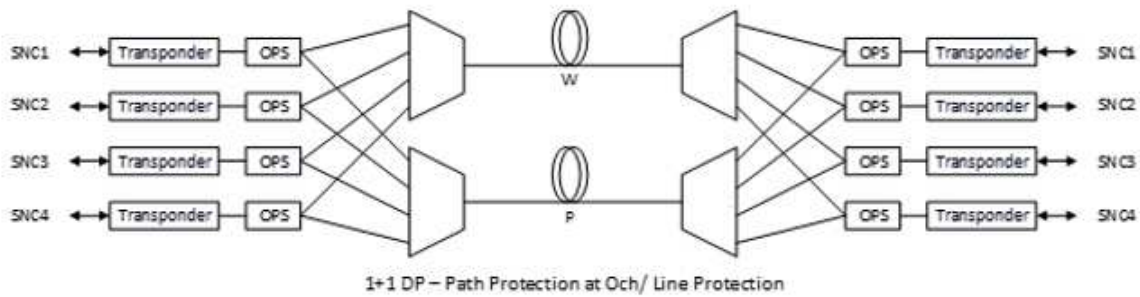

Fig. 3.6: Dedicated Protection Architecture

The following architectures are proposed to support the protection types established in the previous section.

The next architecture (Fig. 3.7) represents that of the selected protection approach. In this instance, 3 out of 4 NMCs, represented by transponders, have an OPS to switch the transponder upon fault. The remaining 3 NMCs are then multiplexed together to form a new MC on the protection path. The 4th NMC has no OPS and is therefore dropped upon fault.

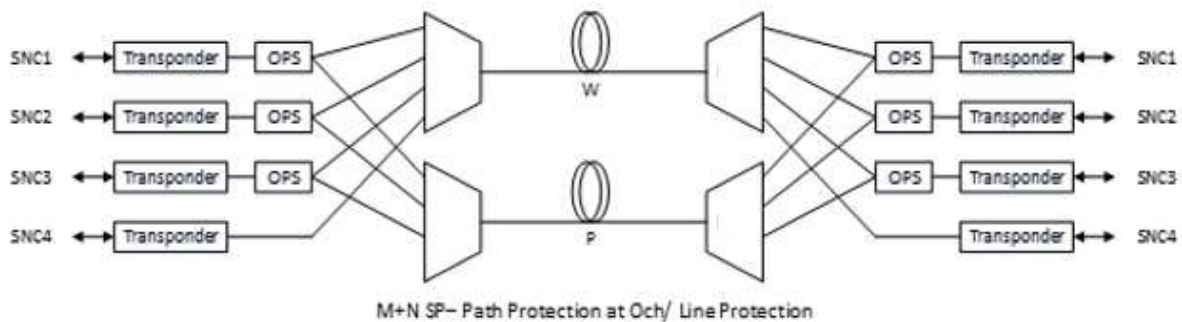

Fig. 3.7: Selected Protection Architecture

The subsequent architecture (Fig. 3.8) illustrates the divided protection implementation. In this example, all NMCs are clearly protected and equipped with OPSs. However, the first two NMCs are protection to protection path P1 forming a selected MC. While, the remaining NMCs are

protected on protection path P2, forming a second MC. Thus dividing the working path MC into two smaller MCs along separate protection paths.

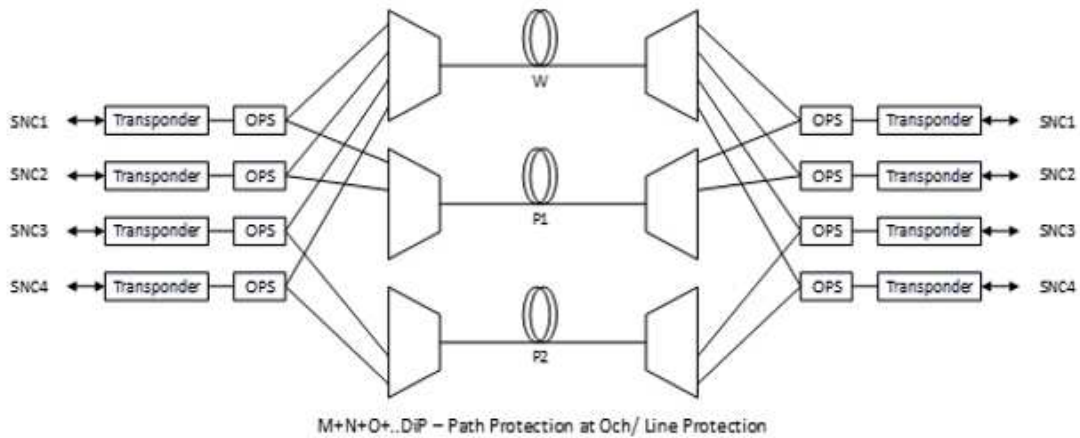

Fig. 3.8: Divided Protection Architecture

The final architecture (Fig. 3.9) demonstrates the mixed protection deployment. The protected NMCs are both divided among separate protection paths and multiplexed into MCs with other working NMCs to form new MCs in the event of a fault. The 4 NMCs are all protected and have designated OPSs, however they are assembled into new MCs with other working NMCs during the fiber fault. As explained earlier, assembling contiguous NMCs into one MC reduces the requirement for guard-bands between divided MCs and therefore increases spectral efficiency.

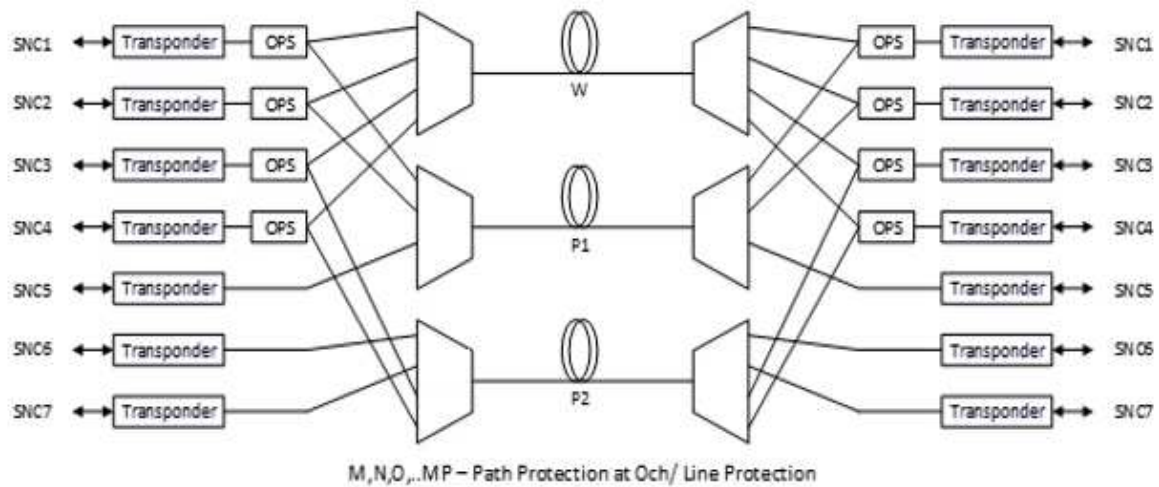

Fig. 3.9: Mixed Protection Architecture

3.3 Proposed Restoration Scheme

The restoration scheme proposed enables network operators the flexibility of restoring at the MC and NMC level, like the previously described protection scheme. The restoration scheme does not require dedicated equipment, as discussed in protection. However, the following and above schemes do assume that the hardware can switch and tune to the more precise flexible grid.

The succeeding flow chart illustrates a high-level view of the restoration process. The key points in the restoration overview, is that the MCs are sorted according to their priority. Then based on priority they are restored based on their restoration level, i.e. the entire media channel is restored, or network media channels are restored on priority basis within a media channel.

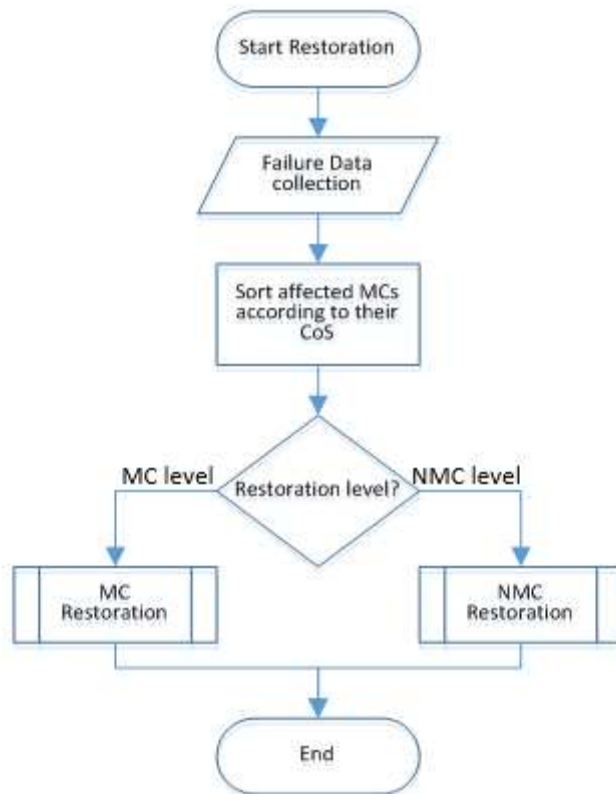

Fig. 3.10: Restoration High Level Flowchart

Below further illustrates the restoration process. If the entire MC is restored, then similar to the NMC's parents MC, they are sorted according to the CoS. All NMCs are restored, if sufficient resources are available. Otherwise the NMCs are restored and dropped on a priority basis.

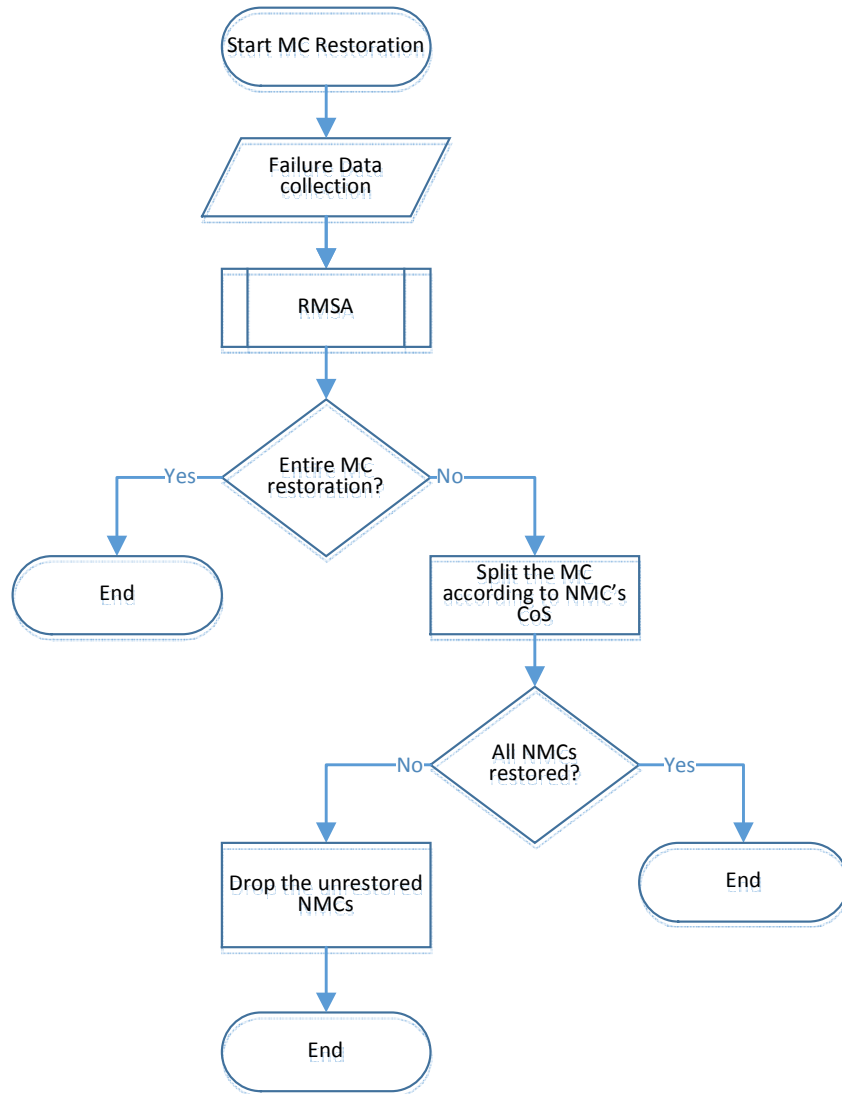

Fig. 3.11: Restoration Flowchart

From the above design, there are many interpretations. In the scope of this thesis, there are 7 cases that are examined, described below.

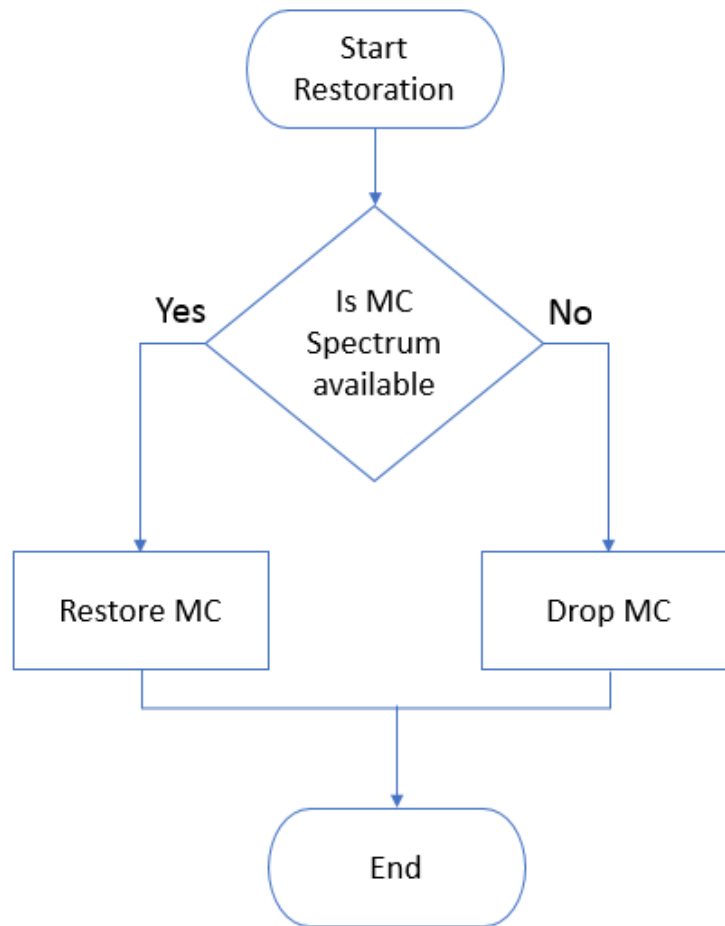

Fig. 3.12: Case 1 Restoration

Case 1: This is the simplest implementation that resembles restoration without CoS in the fixed grid spectrum. The entire media channel is restored on the same spectrum slots, if available. Otherwise, the media channel is dropped.

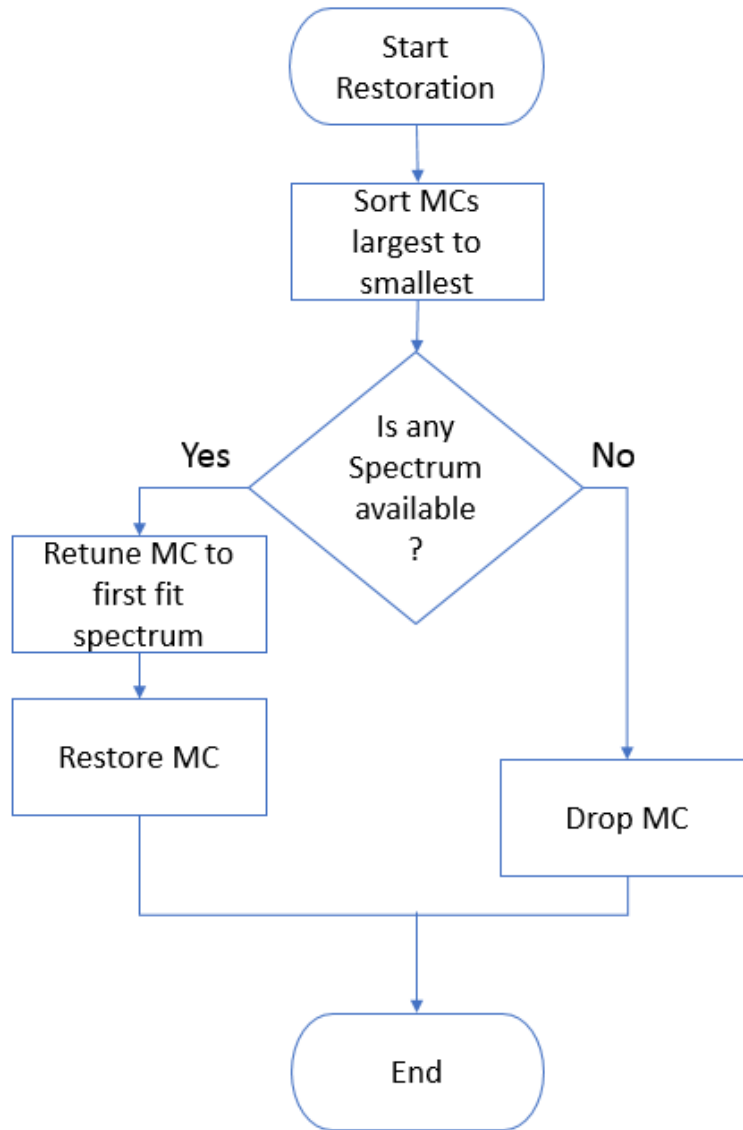

Fig. 3.13: Case 2 Restoration

Case 2: This case resembles an enhanced scenario that may also be implemented in fixed grid restoration. The MCs may be re-tuned to a different wavelength or center frequency, and they are restored based on largest MC size. The entire MC is restored or dropped.

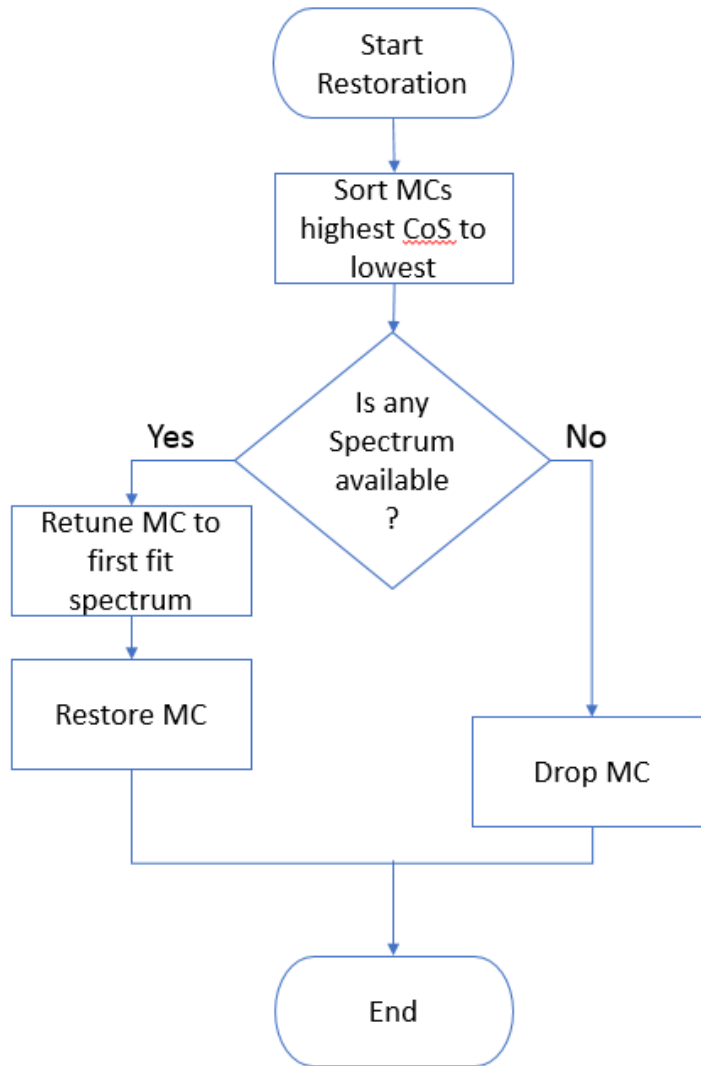

Fig. 3.14: Case 3 Restoration

Case 3: The following case introduces a MC associated CoS. The restoration priority is then restored based on MC CoS, where any spectrum available to fit the entire MC.

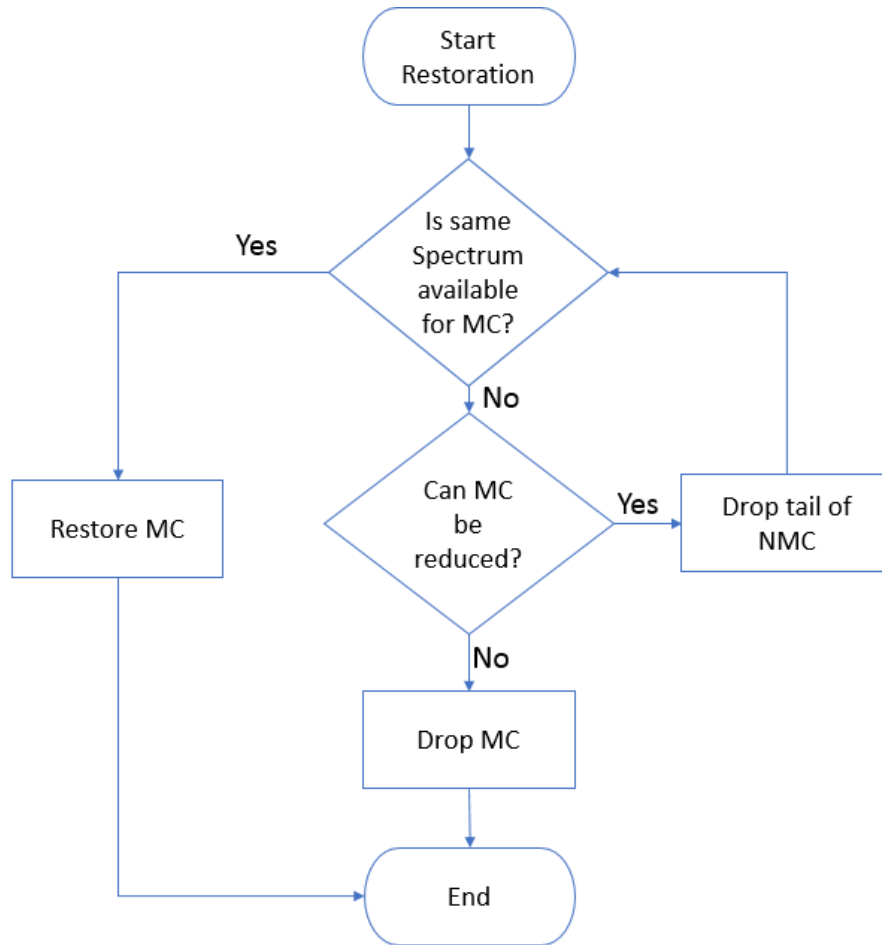

Fig. 3.15: Case 4 Restoration

Case 4: The next case introduces MC reducing from the drop end of the MC. The MC is assumed to be built from lowest to highest spectrum, in order of NMC CoS. The tail end of the NMC was chosen to be dropped since the MC was built through a first fit spectrum assignment policy from highest to lowest priority. Dropping from the tail end ensures that the lowest priority NMC will be dropped first. The tail is cut by dropping the entire NMC.

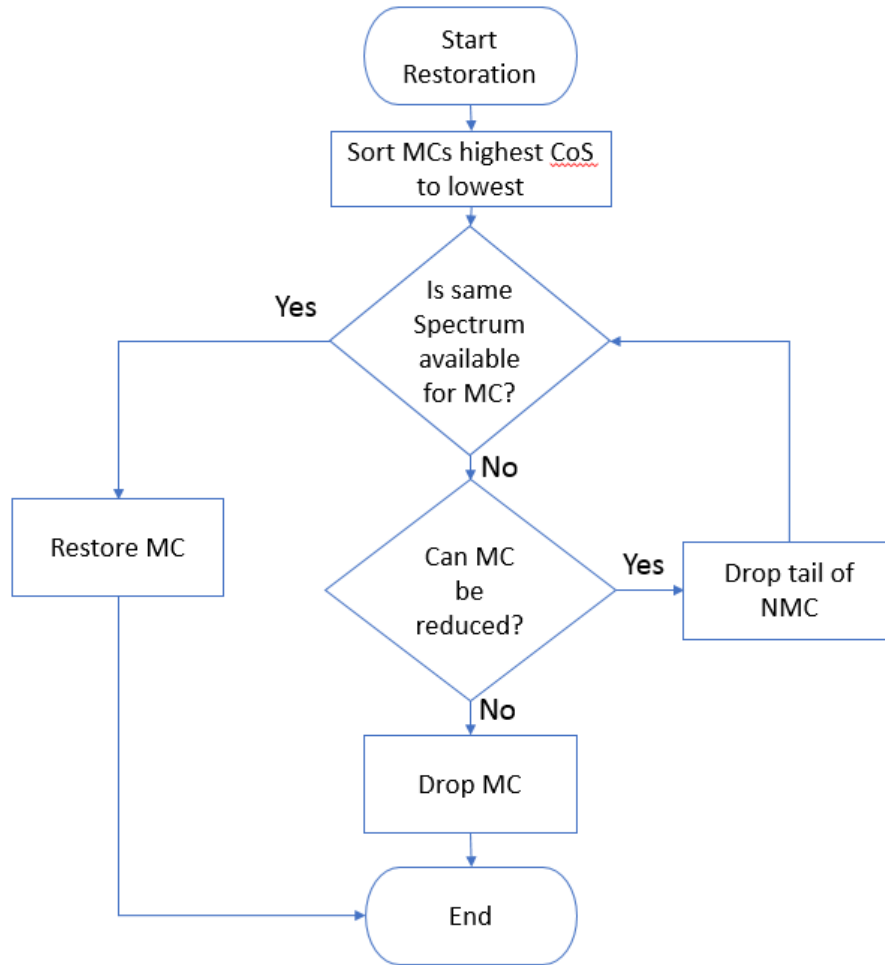

Fig. 3.16: Case 5 Restoration

Case 5: The subsequent case is identical to Case 4, but pre-sorts the MC based on its CoS.

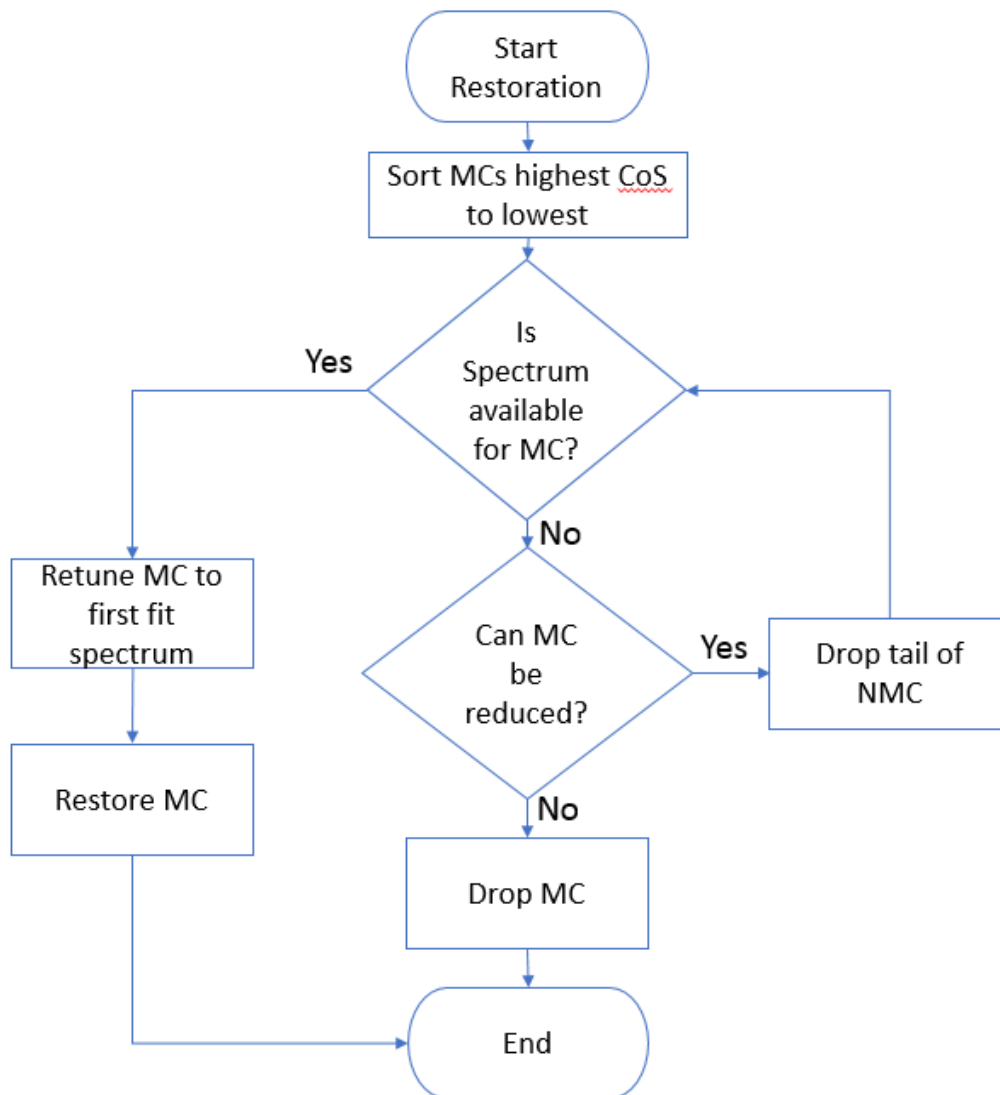

Fig. 3.17: Case 6 Restoration

Case 6: This case incorporates all of the above MC and NMC CoS while retuning the MC to find any available spectrum.

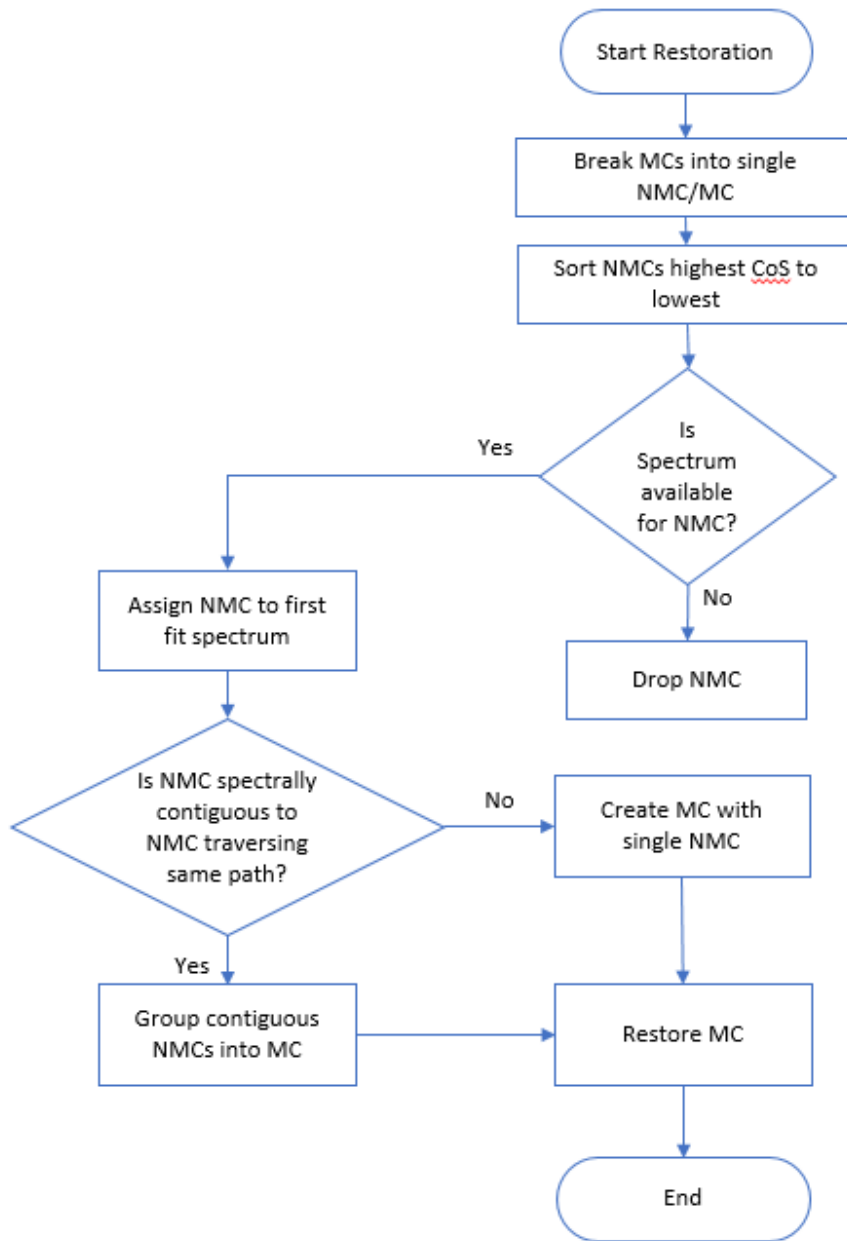

Fig. 3.18: Case 7 Restoration

Case 7: The final case is the most complex and has the opportunity for future work, discussed in Chapter 6. This case breaks the MCs into single NMCs and restores based on the NMC priority. New MCs are then formed with NMCs that traverse the same S-D path and are spectrally contiguous.

The following are the proposed restoration algorithms with and without BWR. During a fault, the MC or NMC will be restored if spectrum is available on a diverse path. In the instance that the entire MC cannot be restored then the NMCs will be individually restored based on CoS. The NMS will group the NMCs by its CoS. The grouped NMCs are restored based on CoS priority, providing the spectrum is available. The NMCs are dropped if they are unable to restore due to lack of available spectrum and there are no lower CoS to be dropped. The restored grouped NMCs form new MCs, essentially splitting the working MC to increase traffic restoration.

Proposed algorithm for elastic restoration

```
IF all MCs can be restored THEN
  restore all
ELSE
  sort MCs according to CoS
  FOR MC CoS 5:1
    IF all MCs can be restored THEN
      restore all
    ELSEIF
      sort NMCs according to CoS
      FOR NMC CoS 5:1
        IF NMC can be restored THEN
          restore
      ENDIF
    ENDIF
  ENDFOR
ENDIF
ENDIF
```

Fig. 3.5: Proposed Algorithm for Elastic Restoration

The following proposed algorithm for elastic restoration with BWR is an extension to the previous proposed elastic restoration. It addresses the situation when the available resources at the restoration time is less than the required to recover all the affected traffic. To accomplish this, the algorithm may reduce the NMC bandwidth that is needed for full restoration. The higher layers should drop some of its aggregated traffic to deal with this bandwidth reduction.

While this proposed technique introduces complexity and design challenges, a successful implementation will restore previously discounted traffic without requiring an increase in pre-allocated spectrum resources.

Proposed algorithm for BWR elastic restoration

```
IF available spectrum < required spectrum
  sort NMCs according to CoS
  WHILE there are NMCs in the list
    calculate required spectrum
    FOR NMC CoS 5:1
      BWR ratio = available spectrum / required spectrum
      offered BW = BWR ratio * original BW
      IF NMC can be restored with the offered BW THEN
        restore
      ELSE
        remove the lowest CoS NMC from the list
      BREAKFOR
    ENDIF
  ENDFOR
ENDWHILE
ENDIF
```

Fig. 3.6: Proposed Algorithm for BWR Elastic Restoration

3.4 Protection and Restoration Implementation

The succeeding section describes the implementation including, proposed channel identifiers, suggested routing and spectrum assignment algorithms, and bandwidth reduction options.

The channel identifiers are proposed in this thesis to implement the protection and restoration schemes introduced above. The channel identifiers were developed to easily identify the type of scheme and granularity (MC or NMC) of survivability. The channel identifiers would be utilized in the optical control plane layer to quickly implement protection or restoration. This technique allows the survivability schemes to be implemented quickly and efficiently in the optical layer, without having to resort to complicated multilayer provisioning.

The below channel identifier is used as a label on the corresponding media channel. The labels are used as follows:

System Design

- MC ID: identifies the media channel. This is unique to each media channel in the network.
- CoS: the class of service, or priority, of the media channel.
1 to 5 = low to high priority
0= no restoration is required
6= the restoration is at NMC level
9= MC uses protection scheme
- Mate ID: correlates the media channel to its protection media channel
0 = the MC is not using protection scheme
- Protection Identity:
0=working MC, 1= protecting MC

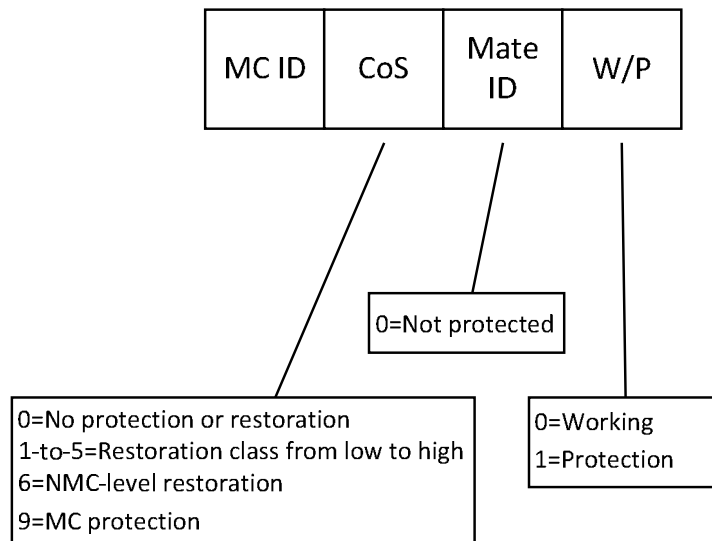

Fig. 3.19: Media Channel Identifier

The following Fig. 3.2 represents the network media channel identifier, or label. This label is only associated with the network media channel within its parent media channel. The label is as described below:

System Design

- NMC ID: identifies the media channel. This is unique to each network media channel within a media channel.
- MC ID: identifies the network media channel's parent media channel.
- CoS: the class of service, or priority, of the network media channel.
1 to 5 = low to high priority
0= no restoration or protection is required
6= working NMC
7= protecting NMC
- BWR = bandwidth reduction is enabled or disabled
- Mate ID: correlates the network media channel to its protection network media channel
0 = the NMC is not using a protection scheme
- Mate MC ID: identifies the network media channels parent media channel
0 = the NMC is not using a protection scheme

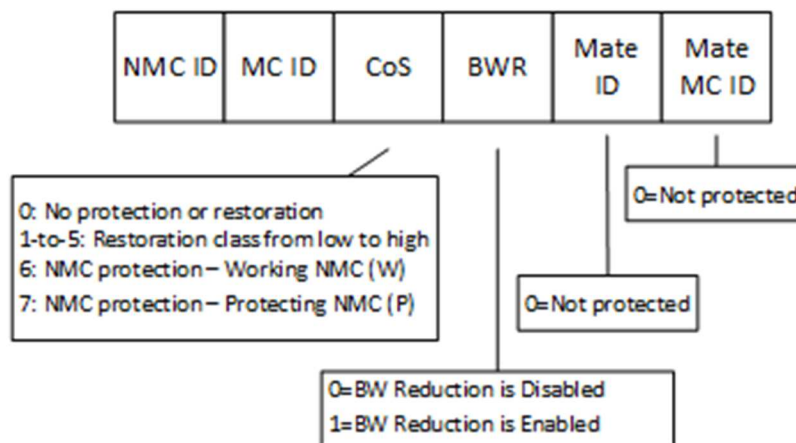

Fig. 3.20: Network Media Channel Identifier

The above MC and NMC identifiers allow the user to provision protection or restoration at their choice of granularity and priority. Thus, keeping the network flexible and elastic according to the customer's requirements.

As discussed previously, the NMC identifier offers a bandwidth reduction flag in its label. This allows this protection and restoration scheme to be utilized in conjunction with bandwidth squeezing survivability techniques. These schemes were discussed in detail in Chapter 2. They aim to reduce resource bandwidth by reducing or slicing off lower priority bandwidth at the edge of a channel. Bandwidth variable transponders are the technology used to levy this technique. While the aim of this proposal was not to incorporate BWR techniques, including a flag for future development is practical. Introducing BWR into the current implementation introduces new challenges that are outside the scope of this thesis. BWR would introduce a significant amount of spectrum fragmentation, especially if the NMCs squeezed are not at the edge of the MC. The NMCs would therefore have unusable spectrum slots adjacent to the other NMCs within the MC.

3.5 Spectrum and routing management

The protection and restoration proposal is optimal when complimented with a beneficial spectrum assignment and routing scheme. Chapter 4: Performance Evaluation, will describe the first fit and YEN algorithm used for simulation to maintain simplicity. However, this proposal may be extended to incorporate better spectrum assignment and routing algorithms improved for elastic optical networks. The aim of this section is to briefly explore other algorithms that may better compliment the previously proposed survivability techniques.

In [ROS12], conventional spectrum assignment policies are examined and compared in terms of blocking probability and network fragmentation. Designing fragmentation aware spectrum assignment policies is important in EONs. Defragmentation is a complicated and intrusive problem, therefore reducing fragmentation through spectrum policies as much as possible is ideal.

The policies examined in [ROS12] are as follows:

- 1) First fit policy: places request in the first available spectrum that fits the demand request
- 2) Smallest fit: allocates the smallest free spectrum first, to reduce and alleviate fragmentation
- 3) Random fit: allocates demands in any available large block of spectrum that satisfies the requested bandwidth
- 4) Exact fit policy: searches for a block of free spectrum that exactly fits the demand requested. Otherwise, allocates the demand in the first largest free block available.

The authors in [ROS12] found that their proposed exact fit policy reduces the total blocking probability slightly. However, the exact fit policy significantly reduced the probability of high fragmentation. As discussed in Chapter 4, the first fit policy was used for simplicity. Pairing a policy such as exact-fit, with the restoration scheme proposed earlier, would complement the scheme well while providing a more efficient and long-term approach to dynamic restoration.

The same idea can be applied to routing in EONs, where [CHE15] has introduced a novel concept to fragmentation aware routing. The author in [CHE15] extends the k-shortest path to a fragmentation aware load balanced scheme that outperforms both the shortest path routing and load-balanced shortest path algorithms in their EON simulations. [TAL14, HOR14, SHE15] offer similar solutions, where routing mechanisms popularized in DWDM networks are extended to incorporate fragmentation, by calculating and adding fragmentation weights to the considered links. These routing schemes would complement the proposed restoration technique well, aiming to reduce fragmentation consequences of dynamic traffic.

Chapter 4. Performance Evaluation

4.1 Introduction

The following chapter provides the details of the network simulation of the proposed algorithms. The network employed in the simulation is the NSFNET network. MATLAB was used to create the simulations. The assumptions in the simulations will be introduced and explored. The pseudo code to generate the traffic will be shared. Finally, the spectrum assignment and routing algorithms utilized are described.

4.2 NSFNET Network

The NSFNET was deployed in the mid-1980s as a research network, which later became the backbone infrastructure for the internet [ROU12].

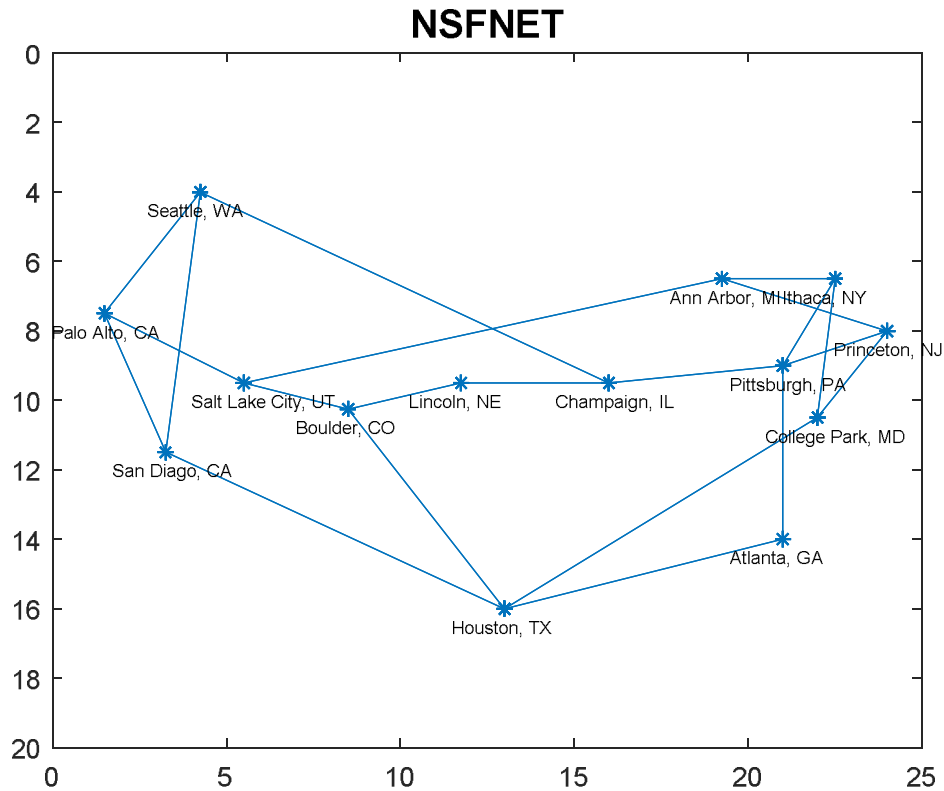

Fig. 4.1: NSFNET Simulation Network

This network was chosen for the simulation since it is a simple mesh network that contains multiple diverse paths. There is one node at Lincoln, NE (above Fig. 4.1), which contains only two branches. This makes it difficult to find diverse paths including that node, so it is omitted from the simulations. Therefore, Boulder, CO is assumed to traverse directly to Champaign, IL.

4.3 Protection Simulation

The following section describes the techniques to simulate the proposed protection algorithms. The assumptions, traffic generation, routing techniques and spectral assignment will be explained.

4.3.1 Protection Assumptions

This section describes the assumptions incorporated to accomplish simulating the proposed protection algorithms effectively. Survivability in EONs require an increasingly complex solution. As discussed in Chapter 3, research in both routing and spectrum management to reduce fragmentation would greatly compliment the proposed survivability techniques. However, to realistically compare various protection mechanisms, a set of assumptions are presumed to simplify the problem.

The switching granularity is the granularity that the MC/NMCs can be switched, added or dropped. All of the equipment, including BVTs must align to this granularity [EGO13]. For the purpose of this simulation, we assumed a switching granularity of 6.25GHz and a frequency slot width of 12.5GHz to align with the G.649.1 WDM grid specification and the industry flexible grid ROADM architecture [MAL14].

Channels require guard-bands to avoid crosstalk between them. NMCs may require various types of guard-bands depending on the transmission characteristics. A routing algorithm that dynamically allocate guard-bands based on the lightpath is suggested in [WU17]. Since we are using standard 37.5GHz channel spacing, a guard-band of 2.5GHz will be used between NMCs and a guardband of 10GHz between MCs, since they travel different paths. For example, a MC with NMCs would occupy the following spectrum:

$$\begin{aligned} \text{Frequency occupied} &= 4 \text{ NMCs} \times 37.5\text{GHz} + 3 \text{ guard-bands between NMCs} \times 2.5 \text{ GHz} + 2 \\ &\text{guard-bands between MCs} \times 10\text{GHz} = 177.5 \text{ GHz} \end{aligned}$$

The number of frequency slots is then:

$$FS = 177.5 \text{ GHz}/12.5\text{GHz} = 14.2 \text{ (rounded up)} = 15$$

The protection scenario becomes much more complex if the MC/NMC does not need to be restored on the same center frequencies. Therefore, to reduce complexity, it is assumed that the NMC on the working paths have the same center frequencies on the protection paths.

To summarize, here is a list of the assumptions made:

- Less than 100 NMCs generated
- MCs are in random size between 4 and 8 NMCs
- NMCs are assumed to be 37.5GHz channels
- Guardband between NMCs are 2.5GHz and between MCs are 10GHz
- There is no re-tuning of transponders (only applicable to protection schemes)

4.3.2 Protection Media and Network Media Channels

The network media channels are 100Gbps channels. 100Gbps channels occupy 37.5GHz or 3 frequency slots ($3 \times 12.5\text{GHz} = 37.5\text{GHz}$) [MAY14]. Network media channels may be multiple sizes, depending on the modulation scheme and bit rate. However, for simplicity, only 100Gbps channels were used in this simulation.

The following pseudo code, describes the method to create NMCs and MCs in Fig . 4.1.

```
-----  
Create NMC  
-----  
while NMCs <100  
    x1= all the nodes in NSFNET  
    x2=4:8  
    X1= 2 random nodes from x1           //NMC has random source and destination  
    X2= random size of x2               //NMC is in a MC between 4 and 8  
    NMCs = sort NMCs by source, destination, and size  
end  
-----  
Create MC  
-----  
NMCTemp = NMCs  
while NMCTemp is not empty  
    MCs = NMCs + NMC guard-bands + MC guard-bands //Add NMCs to MCs  
    NMCTemp = remove NMCs previously added to MCs  
end
```

Fig. 4.1: MC and NMC Creation Algorithm

The MCs created are then used to simulate the protection techniques described in Chapter 3. The next sections will describe the routing and spectrum assignments.

4.3.3 Protection Routing and Spectrum Assignment

Simple and commonly used routing and spectral assignments were implemented to simulate the protection algorithms. The protection MC/NMCs require a working path route and a diverse protection route.

To find the k-shortest loopless paths, the Yen algorithm was utilized, described in [YEN71]. The pseudo code for the Yen algorithm, with Dijkstra shortest path implementation is as follows [28-29], Fig 4.2.

Yen K Shortest Path Algorithm [BOU0]

```
Initialize heap B
Determine  $A_i$  shortest path using Dijkstra's algorithm
For 1:K-1
    Find all shortest paths with the same source and destination
    Add each path to heap B
    Extract minimum cost path from heap B as  $A_i$ 
end
```

Fig. 4.2: Yen K Shortest Path Algorithm [YEN70]

The NSFNET links were all assumed to have a cost of 1 when calculating the available routes. This algorithm was then extended to find diverse protection paths.

The spectrum assignment used is first fit policy. The first fit policy chooses the lowest available wavelength (or frequency) and assigns the connection request to that lightpath [CHA17]. The first fit policy was chosen as it is frequently used and is simple in complexity.

Since the proposed protection is a path protection, the backup path must be link disjoint on an end-to-end basis [ILY03]. Diverse routes were found by finding two paths from the Yen algorithm that did not intersect. The link diverse routes with the lowest average number of hops were used first.

4.4 Restoration Simulation

The following chapter describes the simulation setup for the extended restoration algorithm. While the traffic and routing is similar to that of the protection simulation there are a few key differences that will be outlined below.

4.4.1 Restoration Assumptions

To simulate the restoration cases, the following assumptions were made:

- Less than 84 NMCs, this filled much of the spectrum without blocking working path connections
- MCs are in random size between 3 and 8 NMCs
- NMCs are assumed to be 37.5GHz channels
- Guardband between NMCs are 2.5GHz and between MCs are 10GHz
- Transponders are re-tunable in applicable restoration models

Similar to the protection simulation, assumptions are necessary to ensure that the various proposed cases may be compared without too many variations.

4.4.2 Restoration Media and Network Media Channels

The media and network media channels in the restoration simulation were generated closely to the protection MC and NMC traffic. The key difference in the following MC and NMC generation is that there is an associated CoS with the NMC and MC. The MC CoS was calculated using a geometrical mean [MAN18]. By using a geometric mean, rather than arithmetic mean, the CoS are compounded, which allowed higher CoS NMCs to be more impactful than the lower CoS NMCs (such as 1). The MCs are created with NMCs in order from highest to lowest CoS, Fig 4.3.

MC and NMC Creation

```
t=0;
x1= all the nodes in NSFNET
x2=3:8;
while t <= 84
  t=t+1;
  X1=2 random nodes from x1
  X2=random size of x2
  X3=sort a random CoS between 5 and 1
  NMCs = sort NMCs by source, destination and size
  NMCs cost = calculate the MC CoS based on NMC CoS geometrical mean
end

NMC_temp=NMCs;

while NMC temp is not empty
  MCs = NMCs + NMC guard-bands + MC guard-bands //Add NMCs to MCs
  NMCs_temp = remove NMCs previously added to MCs
End
```

Fig. 4.3: MC and NMC Creation

4.4.3 Restoration Routing and Spectrum Assignment

The routing and spectrum assignment in restoration is the same as described in protection routing and spectrum assignment. The routing is found through Yen algorithm, which utilizes Dijkstra's shortest path. The spectrum assignment policy is first-fit

Alternate routes in the event of a fault are found by assigning a cost of infinity to the affected link and using the same routing assignment to find alternate paths. The fiber cut was caused between Champaign, IL and Pittsburg PA. This link was chosen due since it was the most traffic carrying link.

Chapter 5. Results

This chapter will analyze and compare the results obtained from the proposed protection and restoration techniques discussed in detail in Chapter 3. The network and techniques utilized to attain the performance of the schemes are explained further in Chapter 2. The proposed protection algorithm, including dedicated, selected, divided, and mixed protection will be demonstrated firstly. The restoration comparisons and results will follow.

5.1 Protection results

The techniques analyzed were dedicated, selected, divided, and mixed protection. The spectrum figures have the NSFNET links on the Y-axis, and the frequency slots in the X-axis. The spectrum figures have been rotated to enlarge the figure. In this scenario, we used a full spectrum of 384 frequency slots. Each frequency slot represents 12.5GHz, therefore a full spectrum is 4800GHz. In a fixed grid scenario, the spectrum might be divided into 50GHz, allowing up to 96 channels.

The following is an illustration of a spectrum containing dedicated protection. The blue blocks represent provisioned working traffic, with an assigned value to differentiate connections. For example “W-001” represents the first working traffic provisioned, in each link of the NSFNET network. Its corresponding protection traffic is illustrated in a red block labelled “P-001”. Dedicated protection requires the same amount of spectrum as its working traffic to be reserved. This means that the reserved traffic spectrum (in red) equals the working traffic (in blue).

Results

The spectrum results in Fig. 5.2 were obtained from a selected protection example. As in the dedicated spectrum illustration, the blue blocks represent working traffic while the red represents its protection counterpart. In this selected protection, the protection traffic may be reduced between 0 and 50%, not including MC guard-bands. Each MC is provisioned with a guard-band of one frequency slot (12.5GHz on either end). A visual comparison of the spectrum between selected protection and dedicated protection clearly demonstrates that selected protection requires less spectrum allocated.

The succeeding spectrum results in Fig. 5.3 represents the divided protection implementation. The blue blocks again represent the working media channels. The corresponding protection media channels, in this scenario, are a combination of correlating yellow and orange media channels. Since the protection resources are separated into two media channels, they must traverse separate paths, and hence are represented in different colours. This protection scheme requires more spectrum than selected protection and dedicated protection. This is due to the required guard-bands on each media channel. When dividing the media channel into two separate entities, an extra set of guard-band spectrum is required for the extra protection media channel. This results in more spectrum used than dedicated protection.

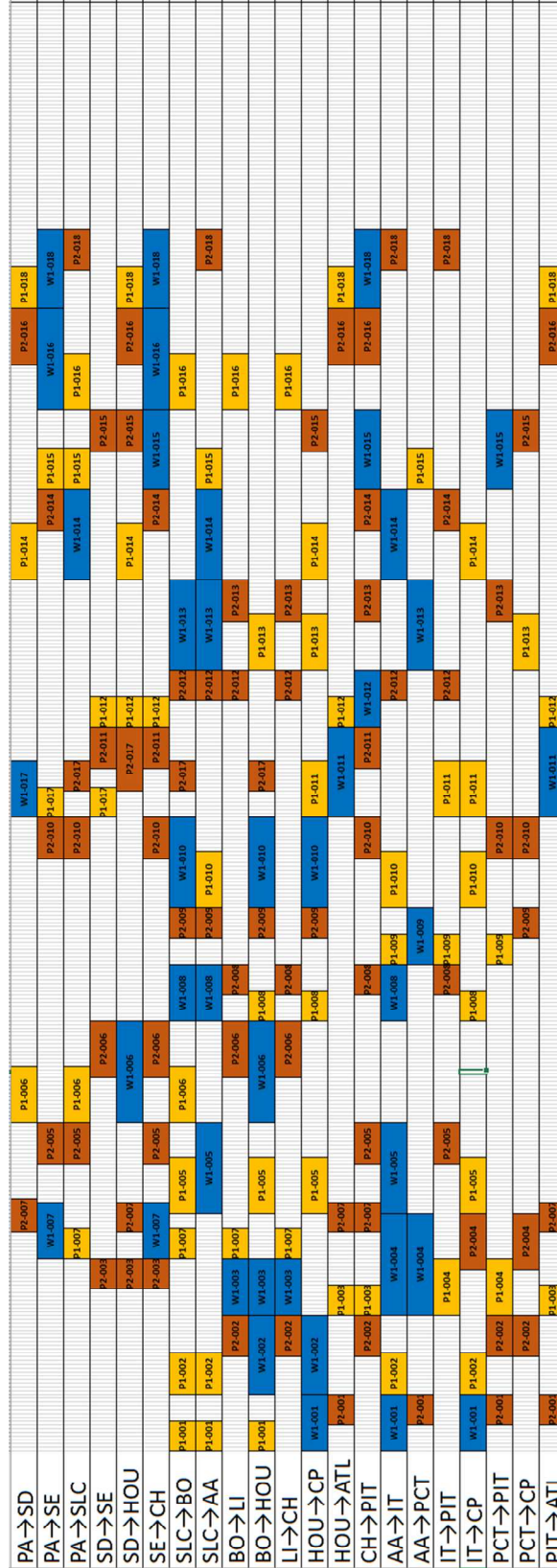
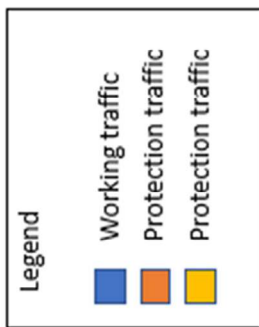

Fig. 5.3: Divided Protection

Results

Finally, the last spectrum diagram illustrates the mixed protection results. In this scheme the working media channel, represented in blue, is divided and reduced into protection media channels (yellow and orange). Dividing working media channels into multiple protection media channels increases required reserved spectrum. However, reducing the protected network media channels into only high priority channels consequently reduces the reserved spectrum.

Results

The protection results are analyzed further, by comparing network capacity, utilization, and fragmentation. As discussed earlier in this section, mixed and divided protection requires the most network capacity.

Network capacity is calculated by the following:

$$\text{Network Capacity Usage} = \frac{\text{total number of slots occupied}}{\text{total number of available slots}} * 100$$

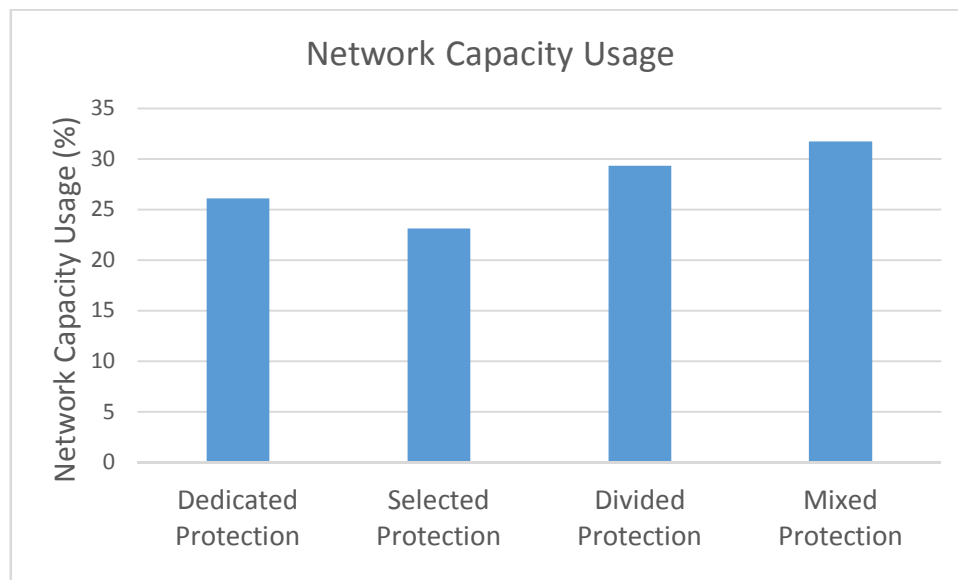

Fig. 5.5: Protection Network Capacity Usage

Network utilization is the number of frequency slots used for both working and protection media channels. As seen very apparently in the spectrum diagrams, the divided protection requires the most amount of frequency slots. This is due to the fact that all working media channels are protected and divided. Therefore, all the working network media channels require a protection counterpart. Also, any divided media channel requires an extra set of dead-bands, further expanding the amount of reserved spectrum required. Selected protection efficiently utilizes the spectrum, while reducing the amount of required reserved frequency slots, more so than dedicated protection.

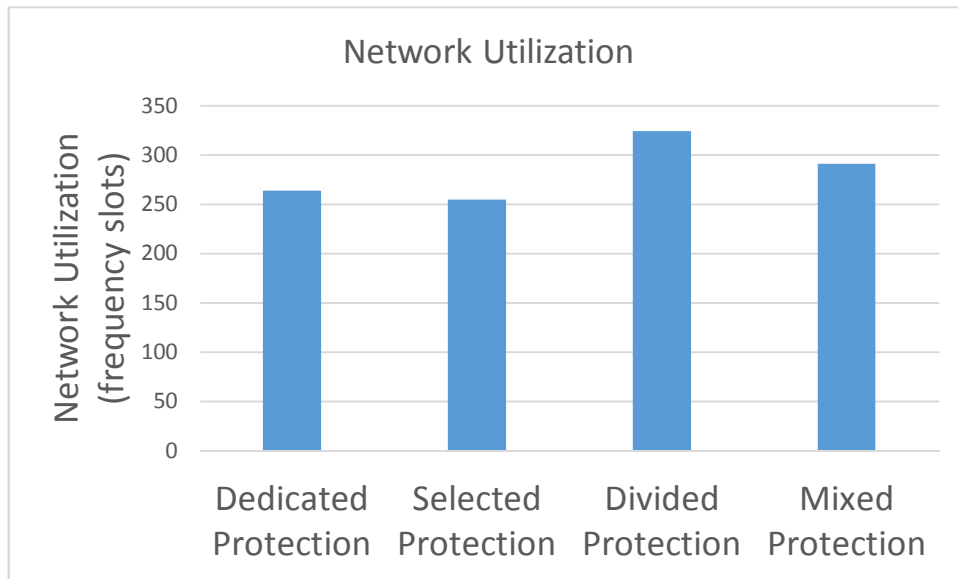

Fig. 5.6: Protection Network Utilization

Finally, an issue repeatedly addressed throughout this thesis is fragmentation. Fragmentation is the amount of unusable frequency slots.

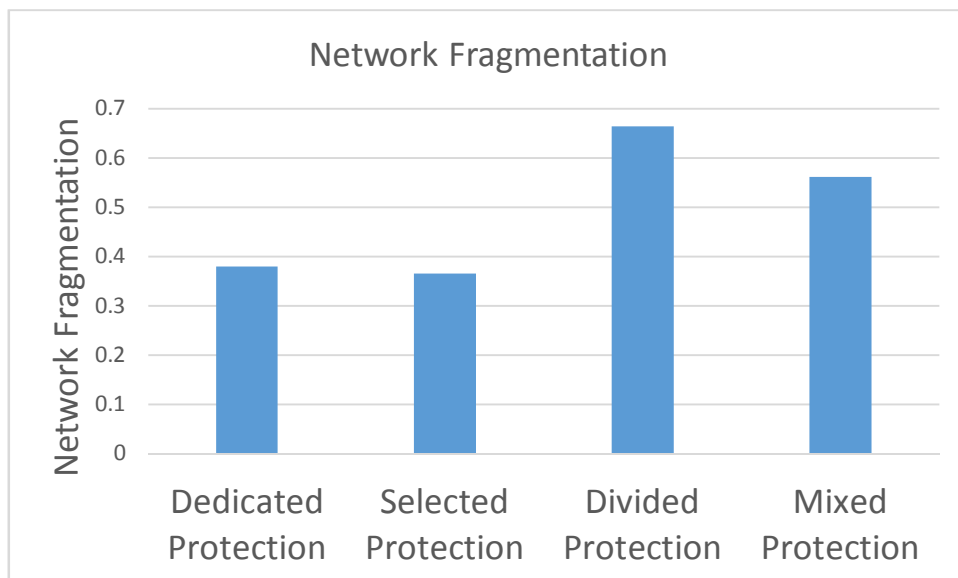

Fig. 5.7: Network Fragmentation

Results

Fragmentation is calculated through the same method as memory fragmentation, as described in [WIL95]:

$$\text{Link Fragmentation} = 1 - \frac{\text{largest free block of spectrum}}{\text{total free blocks of spectrum}}$$

To get the network fragmentation, an average of link fragmentation was taken:

$$\text{Network Fragmentation} = \frac{\sum \text{Link Fragmentation}}{\text{Total Number of Links}}$$

From the results (Fig. 5.7, Fig. 5.6), it is clear that selected protection is an improvement from dedicated protection in both the spectrum utilization and in fragmentation. While divided and mixed protection offer a flexible option, they increase fragmentation and network utilization.

5.2 Restoration Results

The following section illustrates and analyzes the results achieved from the proposed restoration scheme, described in Chapter 3. The 7 cases of restoration scenarios are analyzed under the same traffic scenarios to produce direct comparisons. The blue MCs represent working traffic. Traffic affected from the fiber cut is in red. Yellow traffic represents the faulted traffic after restoration.

The below Fig. 5.8 is a spectrum of the traffic generated prior to a fiber cut. The aim of the traffic generation was to create a network that was heavily utilized whereby not all traffic may be restored. The scenarios were not compared under a lighter traffic load, as all scenarios would restore all MC and NMCs, essentially producing the same or similar results.

The following spectrum in Fig. 5.9 illustrates the network after the fiber cut caused from Champaign to Pittsburg. As seen below, the affected MCs are 14, 5, 10, 13, 19, 25, 35, 3, 9, 53, 62, 67, 73, 75, 79, and 81.

Results

Case 1, illustrated in Fig. 5.10 is the spectrum output of the simplest restoration. This restoration only allows the entire MC to be restored, without any option to re-tune. In this scenario, any MCs that do not have available spectrum at the same frequency are dropped in the event of a fault.

The next scenario, Case 2, or Fig. 5.11 restores the entire MC. In this case, the MCs have the option to retune if the spectrum is not available, based on first-fit policy. This enables MCs that would have been previously dropped due to occupied frequency, to retune to an available frequency and be restored in the instance of a fault. MCs are restored based on size, as it is assumed if all traffic has no priority, then the preference is to restore the largest MC first, and thus the most NMCs.

Both Case 1 and Case 2 are similar to current fixed grid implementations. Case 2 is an evolution of Case 1, if tunable transponders are available. While different spectral assignment and grooming techniques may improve the capacity of traffic restored, there is no associated CoS with either the MC or the NMCs.

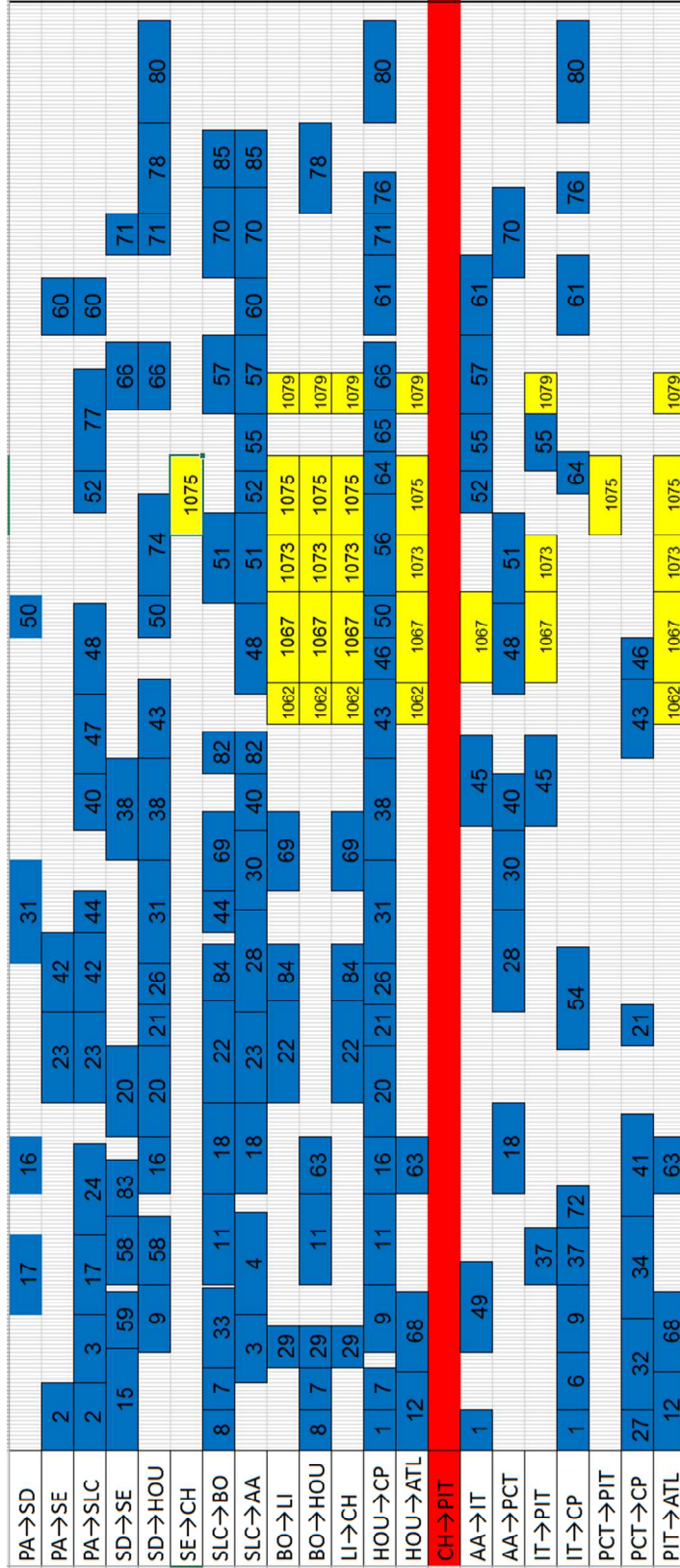
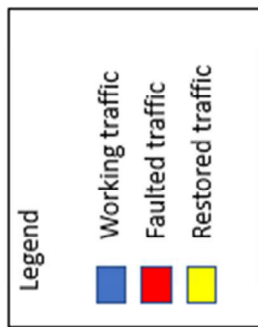

Fig. 5.10: Case 1 Restoration

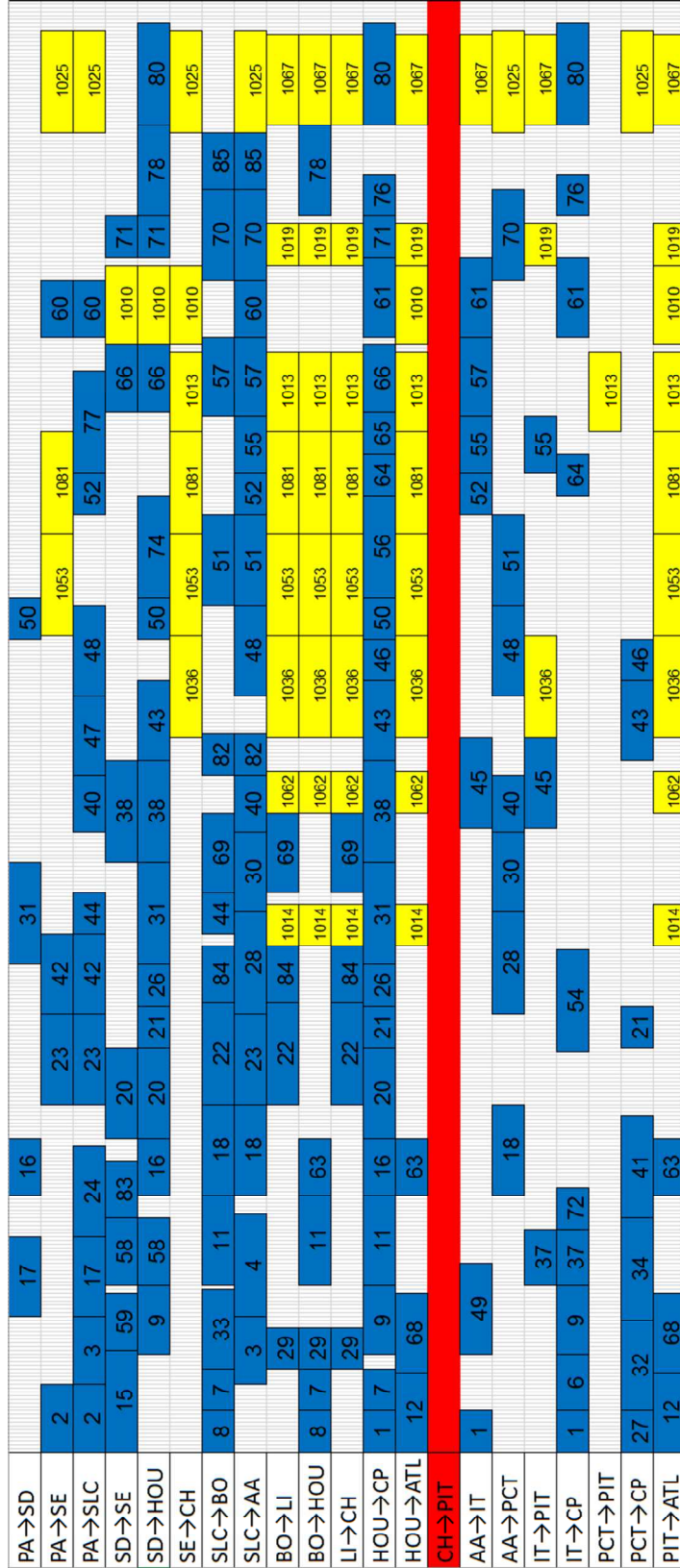
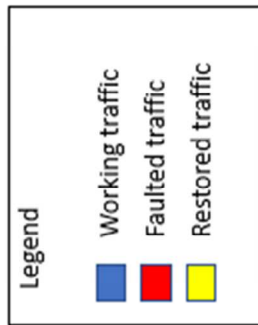

Fig. 5.11: Case 2 Restoration

Results

Case 3, Fig. 5.12 introduces the CoS assignment proposed in Chapter 3. The CoS is only associated with the media channel in this case. While this case is similar to Case 2, the MCs are now sorted and restored based on their CoS. This enables the highest priority traffic to take precedence during a link fault. While this scenario extends restoration to include priority, only the MC as an entire entity is restored, and the NMCs are not considered. It is assumed that higher priority MCs contain high priority NMCs. Similar to Case 2, the MCs also have the option to retune to available spectrum.

The following Case 4, Fig. 5.13, restores the media channels to the same spectrum slots (ie. no re-tuning). This is the first Case where the restoration is resolved at the NMC level. The NMCs are dropped from the tail end of the MC to allow the MC to restore if the spectrum for the entire MC is unavailable. The NMCs are ordered from highest CoS to lowest within the MC, so the lowest NMCs are dropped first. This scenario does not yet introduce re-tuning and consequently must drop NMCs that do not fit in the same spectrum.

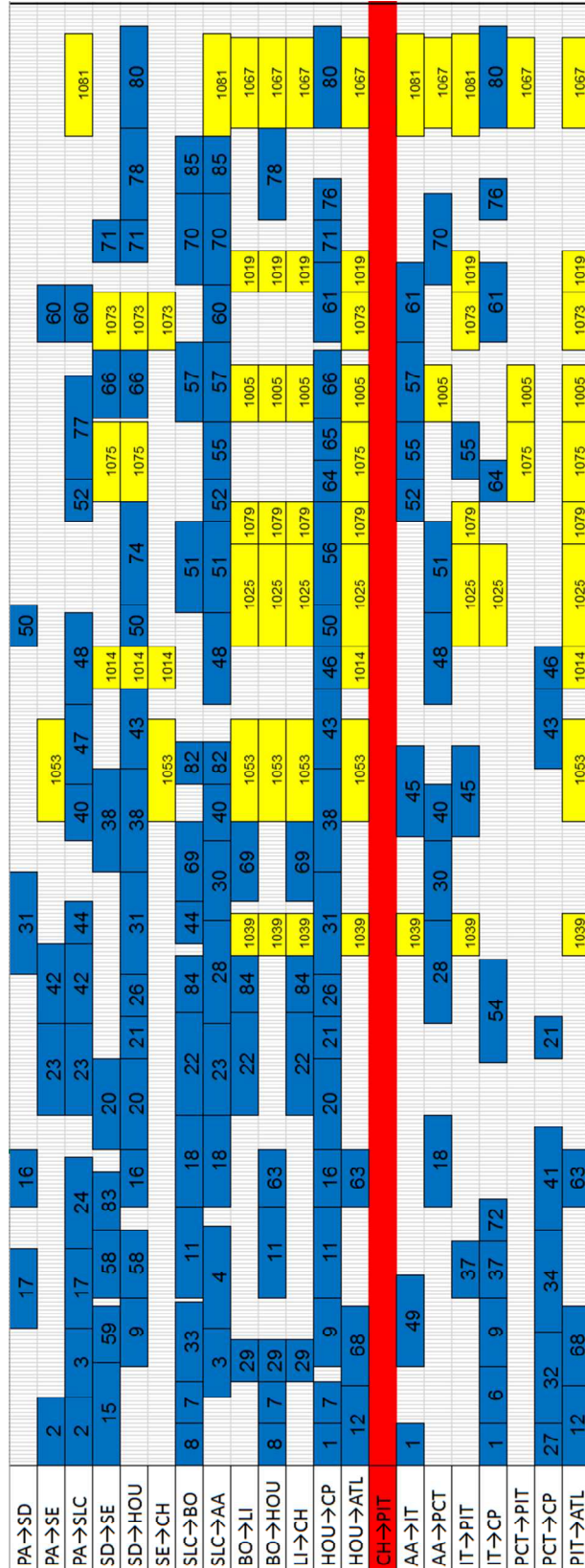
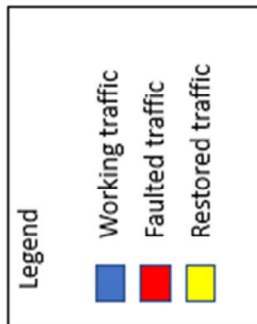

Fig. 5.12: Case 3 Restoration

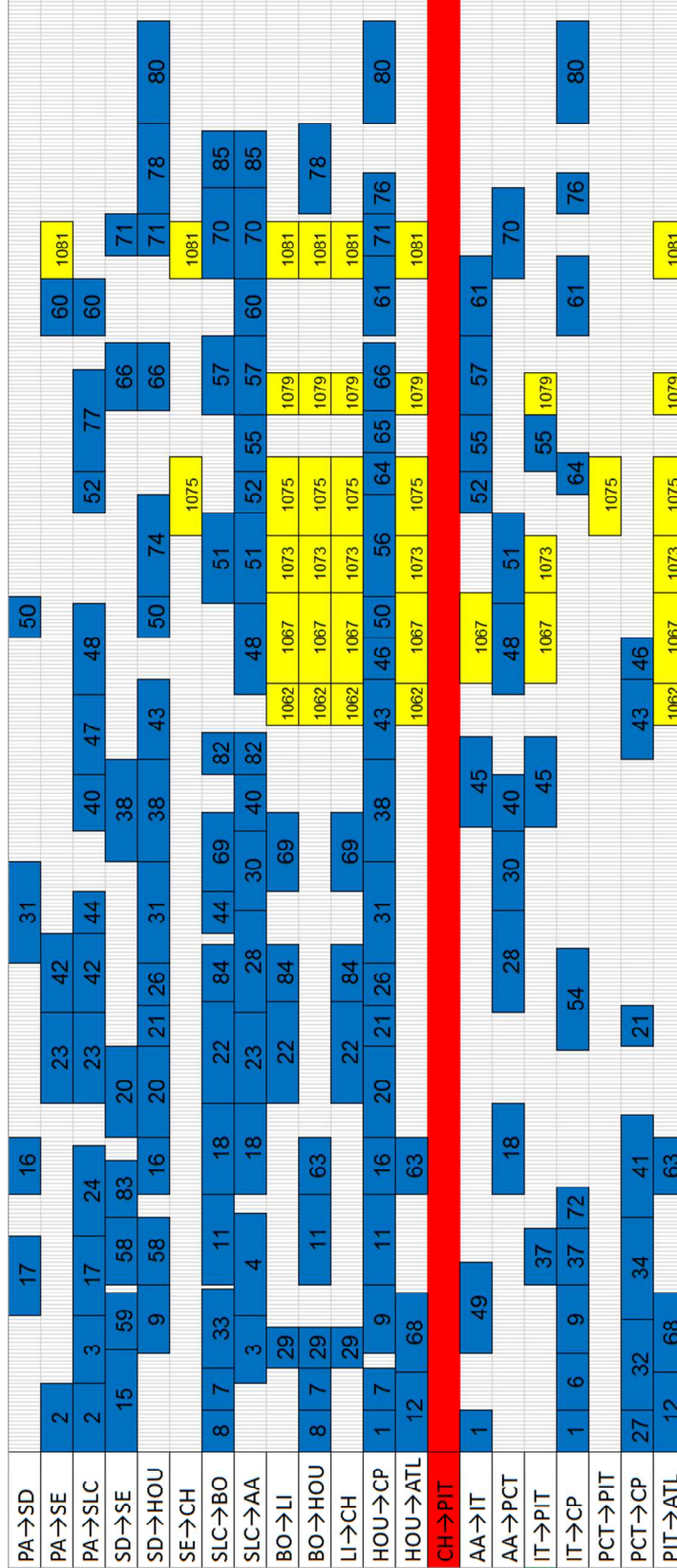
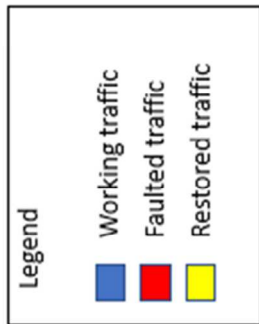

Fig. 5.13: Case 4 Restoration

Results

The next Case, Fig. 5.14, yielded the same spectrum output as the above scenario. Case 5 is identical to Case 4, but restores the MCs based on highest CoS first. Since there is no re-tuning, it would not matter in which order the MC is restored, as they do not compete for the same frequency slots. It is clear from Case 4 and 5 that re-tuning must be available to prioritize NMC traffic by CoS. Fig. 5.13 and Fig. 5.14 clearly indicate that removing the ability to re-tune to a different frequency during a fault significantly impacts the restoration. When a diverse source to destination path has any links with the same occupied frequency as the faulted channels, there is absolutely no possibility to recover that traffic. Sorting the traffic by CoS or by size does not contribute to the restoration in Case 4 and 5 since they occupy different spectrum. The restoration solely relies on the same spectrum being available on a diverse path.

Case 4 and 5 may be compared to Case 1 since it also does not allow the transponder to re-tune. In Cases 4 and 5, MC 1081 is restored where in Case 1 it is dropped. In Case 1, the MC 1081 is not reduced in size and therefore conflicts with occupied spectrum on link BO->HOU. Case 4 and 5 reduce the size of the MC to not overlap the working MC 78.

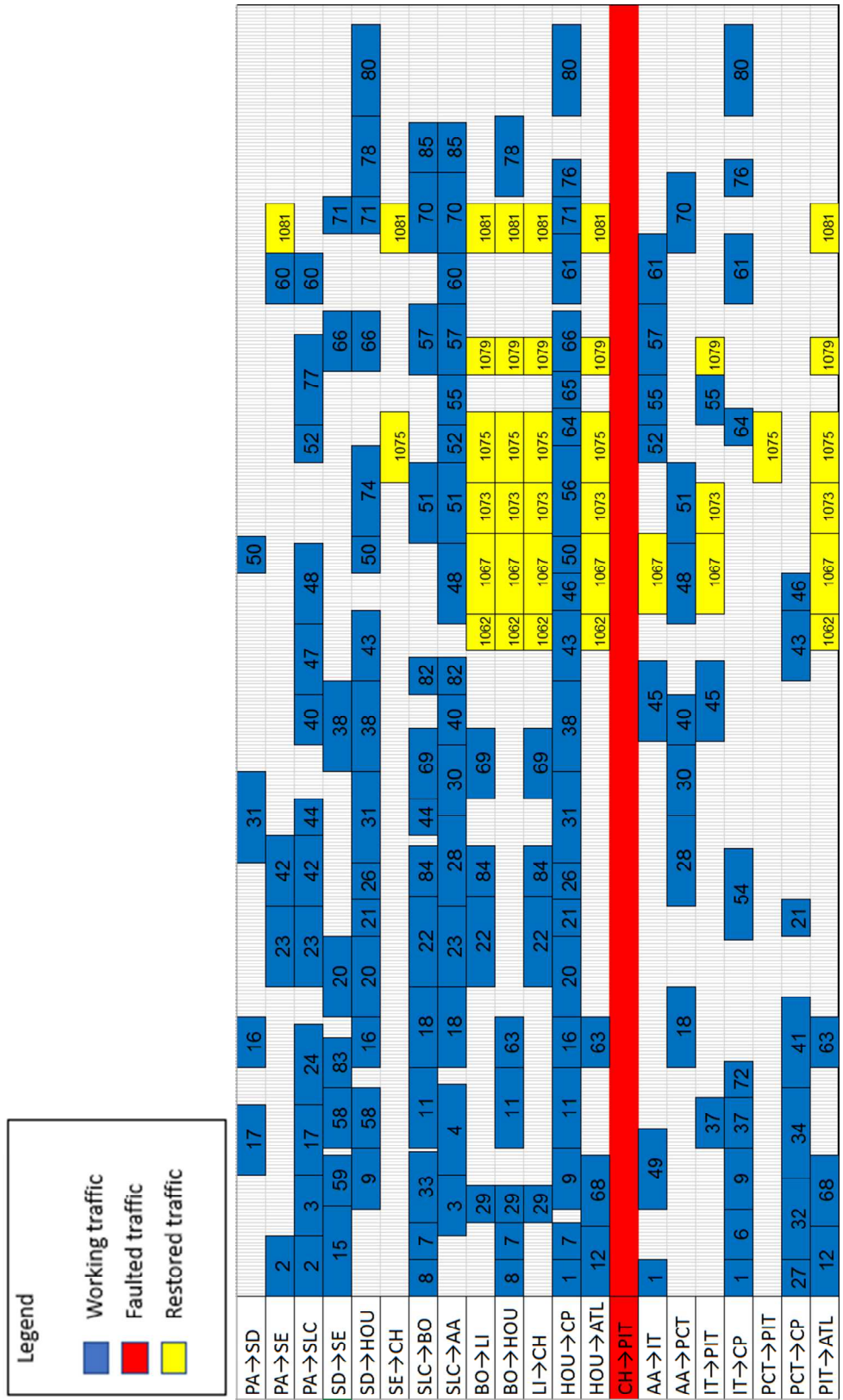

Fig. 5.14: Case 5 Restoration

Results

The last two scenarios are the best examples of utilizing the proposed restoration with an assigned CoS. Case 6 restores the MCs based on highest CoS with the option to re-tune to available spectrum. This case also drops tail end, low-priority, NMCs that do not fit into the spectrum assignment. This scenario encompasses all of the benefits of the newly proposed restoration scheme by applying a CoS to both the MC and NMC in the event of a fault. As seen in Fig. 5.15, the NMCs previously unable to restore are not squeezed to fit into available spectrum. For example, the restored traffic “1010” in Case 3 was not able to be recovered since it was too large for the available spectrum on any recovery path. Reducing the size of the MC by dropping the tail end NMCs allowed the higher priority NMCs in MC 1010 to now be restored.

Finally, the last case caters to strictly NMC CoS. The MCs are broken into single NMC/MC entities. The NMCs are then assigned and restored based on highest NMC priority. If the NMC is spectrally contiguous to another NMC, and the NMCs traverse the same path, then the NMCs are combined into a single new MC. Fig. 5.16 illustrates this concept. Since the MCs are broken into multiple NMCs, the MCs restored in Fig. 5.16 are comparatively much smaller than the MCs restored in Fig. 5.15. This is due to the Case 6 only squeezing an MC, where Case 7 breaks the MC into its individual NMCs.

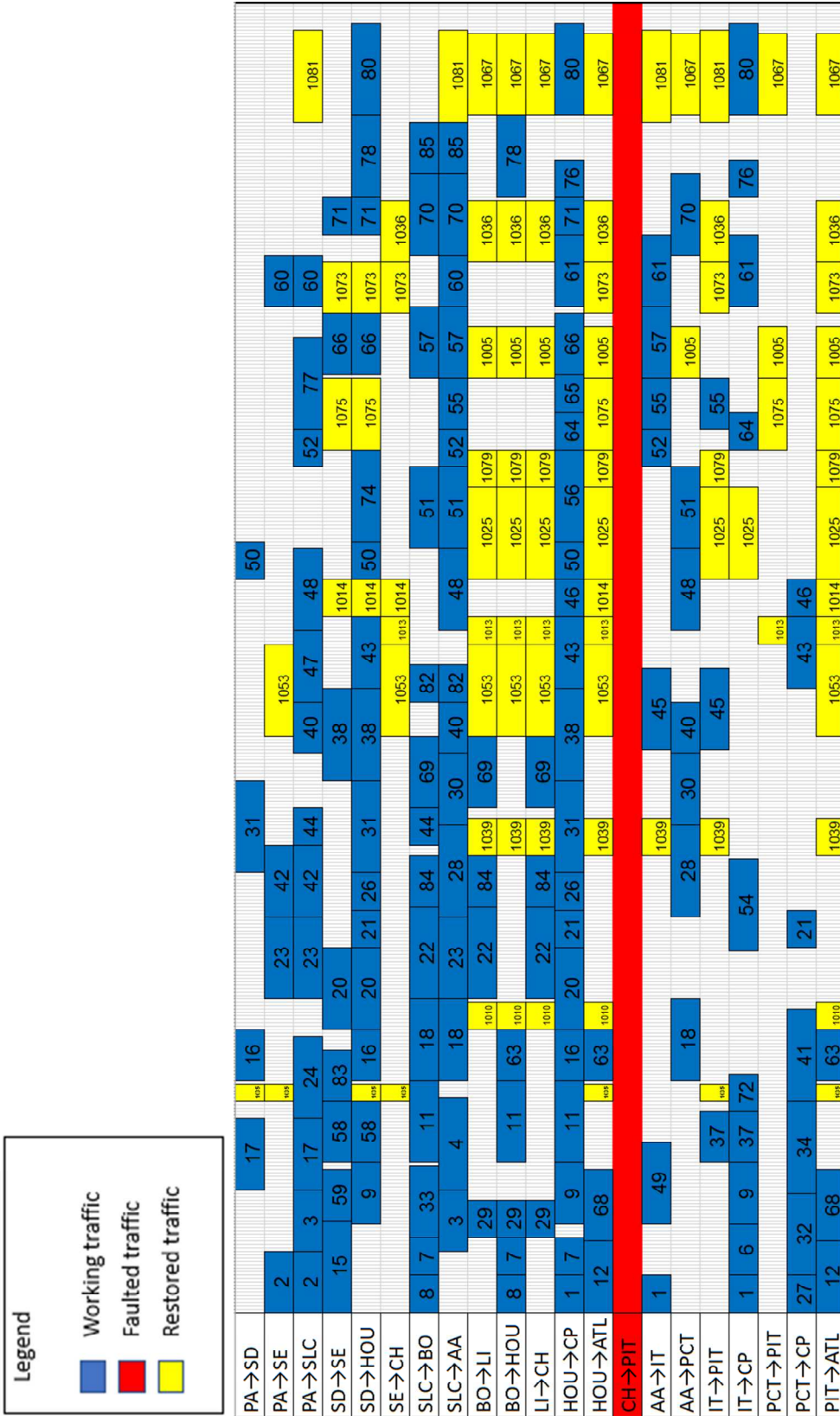

Fig. 5.15: Case 6 Restoration

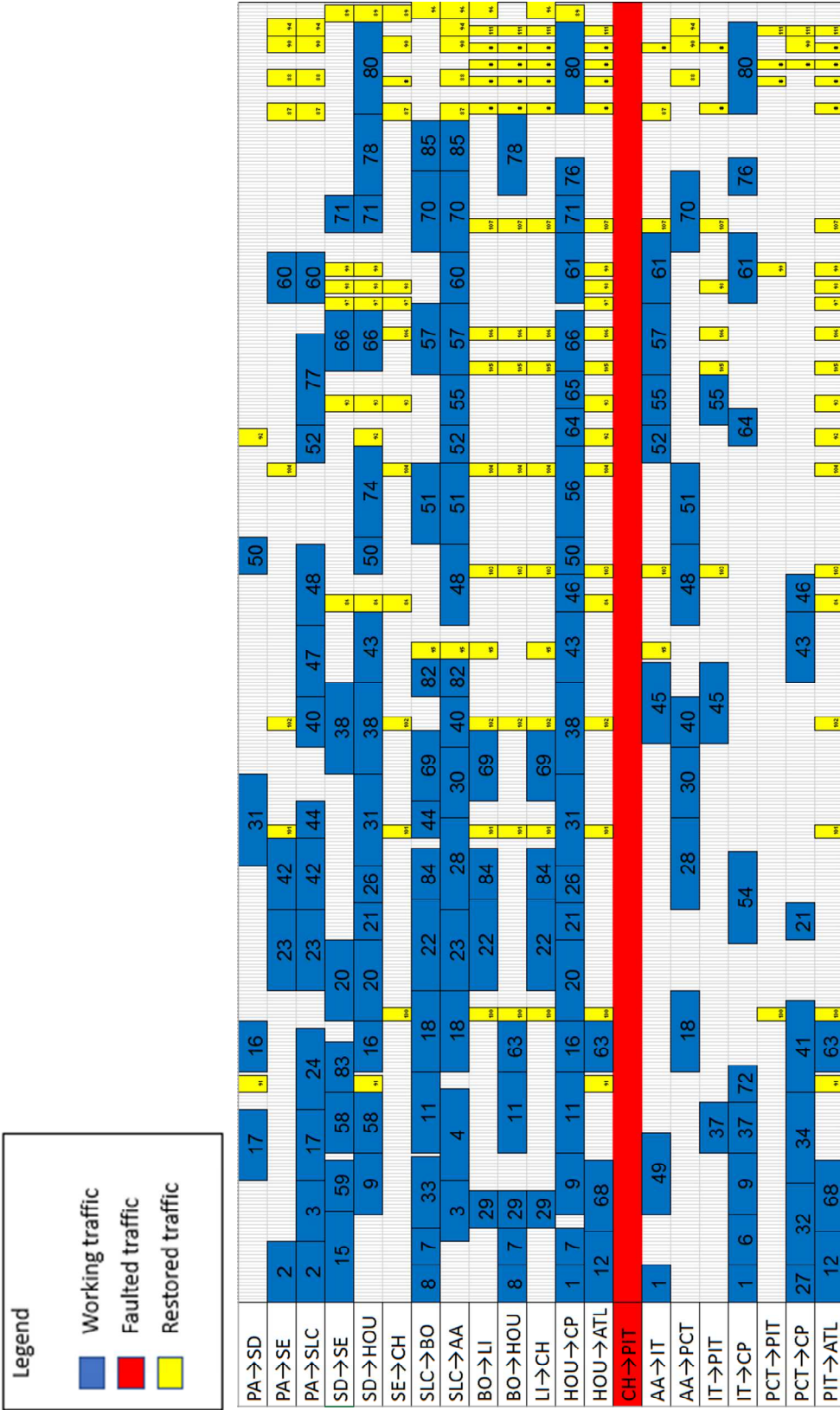

Fig. 5.16: Case 7 Restoration

Results

While the outcome of the above described scenarios is intuitive in most cases, it is worthwhile to compare the scenarios through a quantitative analysis. The below comparisons illustrate the number of MC or NMCs restored. The goal of dynamic restoration is to restore as much traffic as possible, while prioritizing higher quality traffic.

The subsequent two graphs illustrate the total MC and NMCs restored. From the below results, it is obvious that not being able to re-tune transponders in the event of a fault (Case 1, 4, 5) significantly reduces the number of MCs and NMCs able to be restored. When comparing the cases with re-tunable transponders, case 2, 3, and 6 yielded the best restoration results for NMCs. While case 7 restores the highest priority NMCs, breaking the NMCs into single NMC/MC is not spectrally efficient.

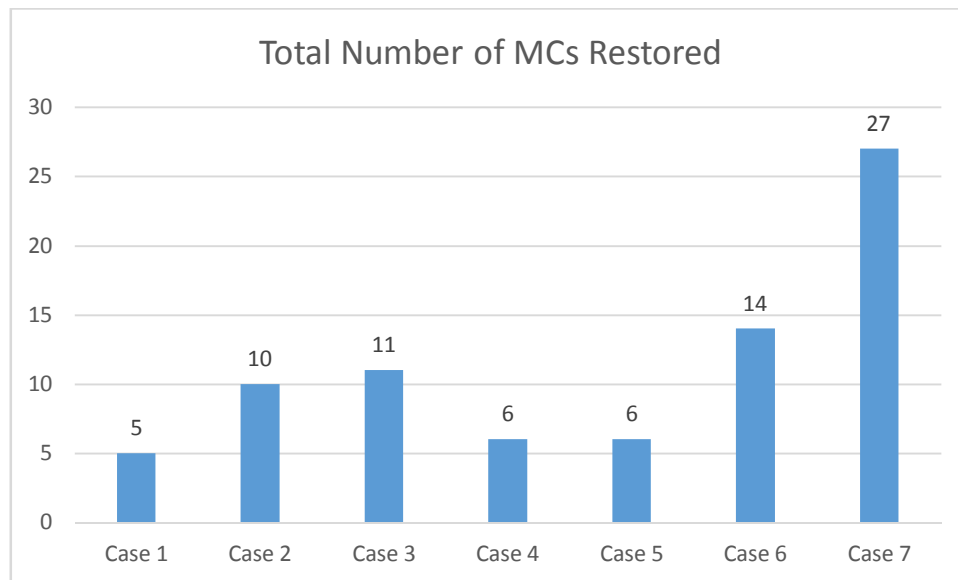

Fig. 5.17: Total MCs Restored

Results

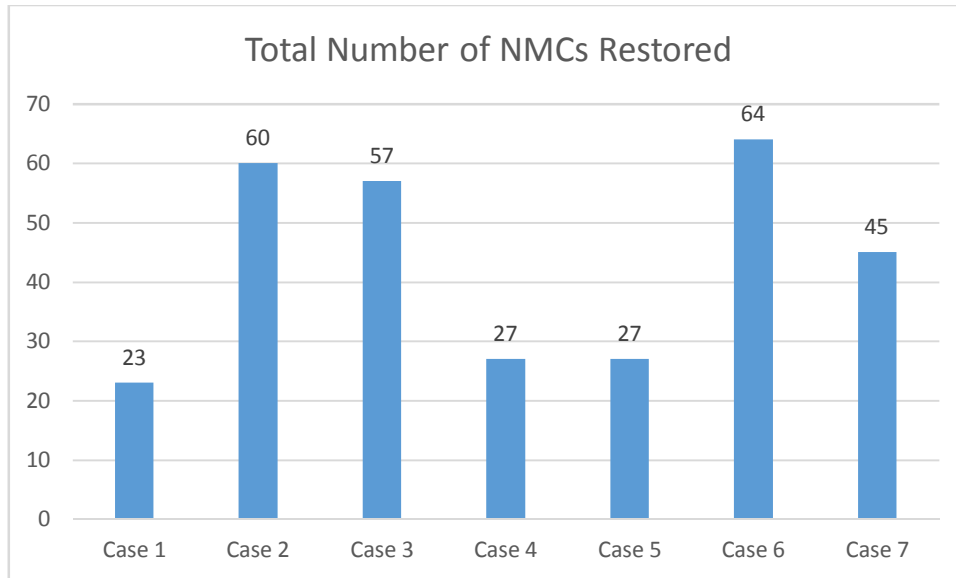

Fig. 5.18: Total NMCs Restored

Further examining the results in Fig. 5.19, case 6 and 3 had the best results for high priority traffic. This is due to prioritizing the restoration based on CoS. In case 3, the restoration is based on highest MC CoS, while case 6 relies extends the CoS by dropping lower priority NMCs that do not fit in the spectrum. Case 7 appears to restore the highest number of high priority MCs, but this is skewed since many NMCs are dropped from the MC to restore.

Results

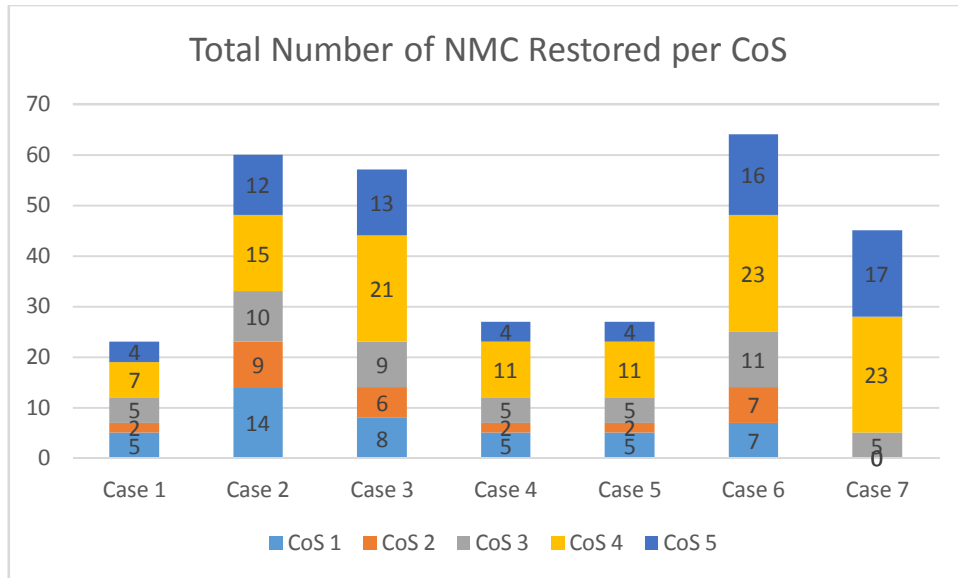

Fig. 5.19: Total NMCs Restored with CoS Breakdown

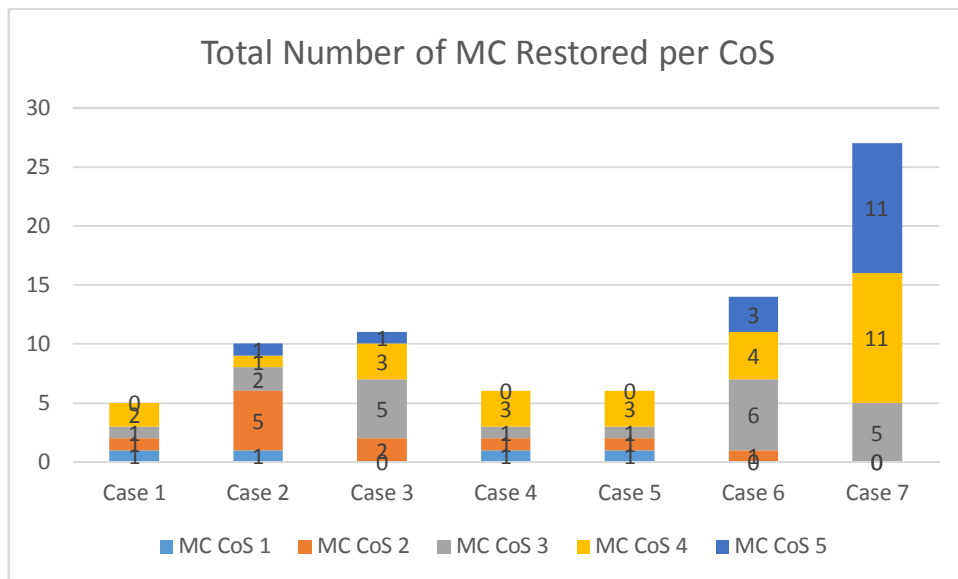

Fig. 5.20: Total MCs Restored with CoS Breakdown

Analyzing only the highest priority MC and NMCs (CoS = 5), case 7 yields the best results, followed closely by case 6. In this scenario, the network operator would have to outweigh the

Results

benefits of the highest priority traffic being restored, or most of the highest priority followed by best effort in order of priority of traffic.

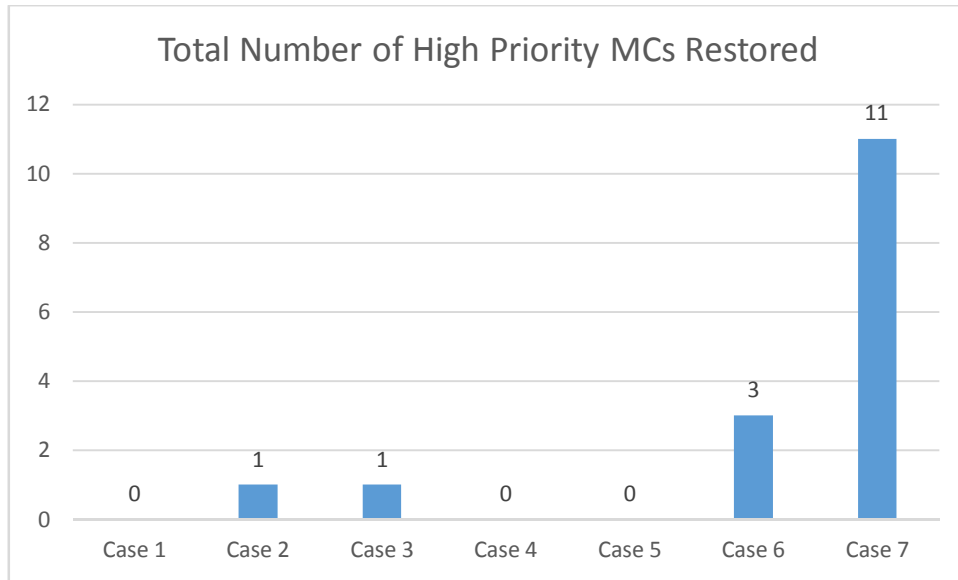

Fig. 5.21: High Priority MCs Restored

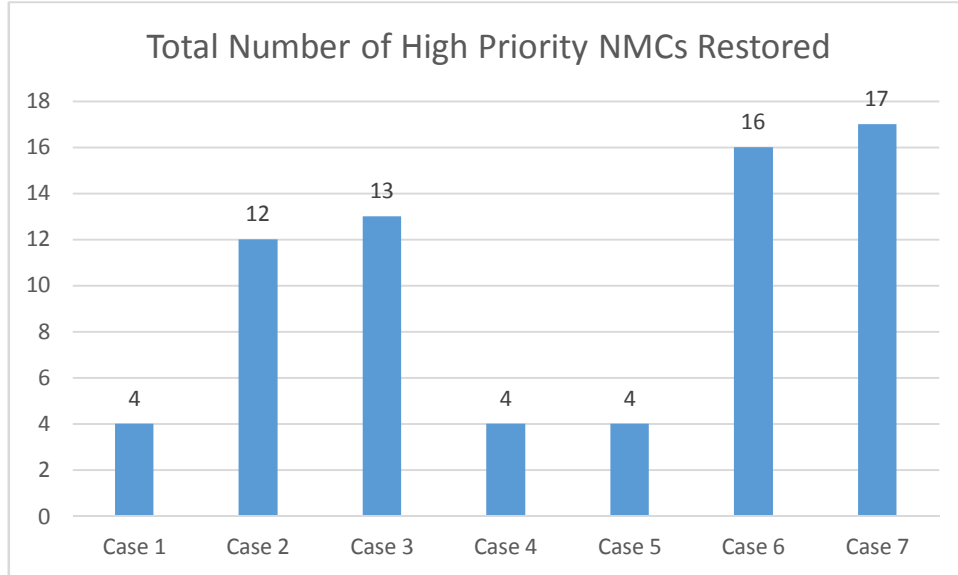

Fig. 5.22: High Priority NMCs Restored

Results

Finally, the network capacity usage, defined in the previous section, did not vary significantly. The cases without retuning, had the lowest capacity usage as spectrum was available for MC/NMCs to be restored but not utilized as seen in Fig. 5.23.

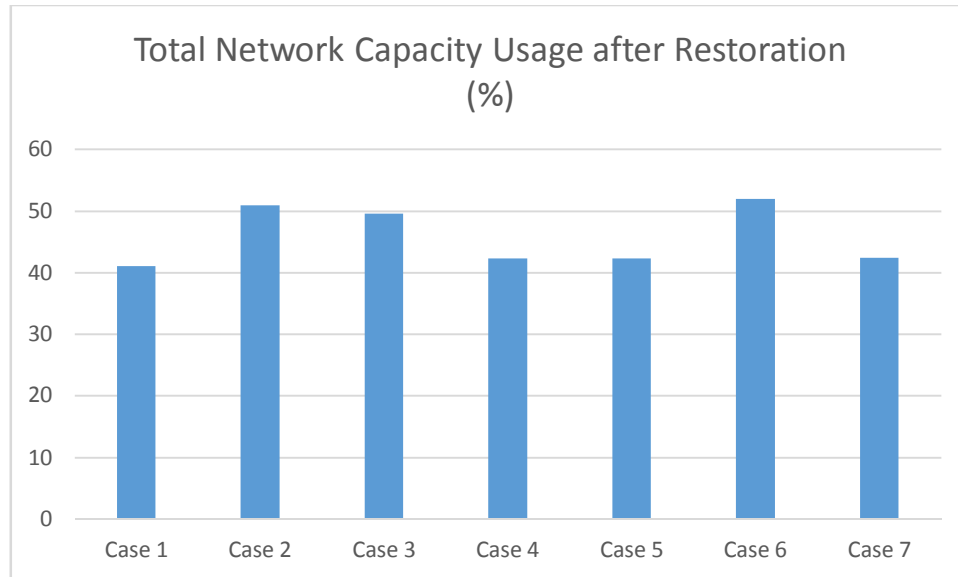

Fig. 5.23: Network Capacity Usage After Restoration

5.3 Confidence Interval

In this dissertation, the proposed protection and simulation schemes are simulated using its mathematical model as a simulation model. This means that the computer world is the same as real world and both the conceptual model and the computer model are the same as the real model in simulation terminology. Hence, the purpose of the simulations performed in this thesis are to provide a proof of concept to the protection and restoration schemes proposed by performing white-box verification. Assumptions described in Chapter 4 were made to ensure the models were accurate to conceptualize the models on NSFNET. Simulation result data confidence is assured as the validation tests are not required. The white-box verification that is completed in this chapter ensures that the computer model is true to its conceptual model

Results

[ROB97]. This thesis aimed to understand the real world problems imposed by EONs and the enhancements required for survivability.

Chapter 6. Conclusions and Future Work

6.2 Conclusions

Elastic Optical Networks offer a unique opportunity to improve current protection and restoration schemes in the predecessor fixed grid networks. Spectrum efficiency and traffic flexibility are important design considerations that increase the capacity of optical transport networks. BVTs, flexible WSSs, and flexgrid spectrum are the underlying technologies that encourage EONs.

Previous work in the area offers an extension to survivability of a single variable transponder. However, there is still a gap in protection and restoration of multiple transponders in a flexible system. This thesis aims to alleviate that gap by offering a proposal to both protection and restoration in EONs, by taking advantage of the finer granularity in EONs.

An innovative approach to survivability in EONs is introduced. Protection and restoration algorithms extending current implementations to incorporate a MC and NMC hierarchy are presented. A protection architecture is also introduced to apply the technique in practice. Spectrum assignment and routing algorithms are also explored to compliment the proposed techniques.

The aim of the simulation was to provide the most realistic traffic to implement the proposed protection and restoration schemes in. There are many variations of simulation and complexity that are possible. By creating assumptions and offering a baseline network traffic with first fit policy spectrum assignment and k-shortest-route routing algorithm, the models are able to be compared, without an assortment of diverse variables.

Conclusions and Future Work

The proposed “Selected protection” prioritized higher quality of traffic by only protecting high CoS NMCs and dropping low priority NMCs during a fault. Selected protection proved to be an improvement to the dedicated protection, where both low and high priority NMCs are protected. Selected protection reduced network capacity usage and network utilization over its predecessor dedicated protection. Divided protection divided the MC into multiple MCs along separate protection paths. This type of protection actually consumes network capacity and produce fragmentation. That is due to the increased guard-band usage for the increased number of MCs. Mixed protection incorporated divided MCs and selected protection to protect its working MCs. While this protection also consequently had a higher network capacity consumption and fragmentation created, it was less than divided protection. Divided or mixed protection may be beneficial to network operators that do not have sufficient bandwidth to protect the entire MC. In this scenario, mixed or dedicated protection is an attractive choice since NMCs that would have previously been dropped are now able to have protection.

The restoration cases found to restore the least number of MCs and NMCs were cases 1,4, and 5. This is due to these cases being limited by no transponder re-tuning. Therefore, if the same frequency was not available on a separate path then the traffic was dropped. When comparing these three cases, it was found that dropping the tail end NMCs (lower priority traffic), increased the total amount of NMCs restored. Sorting the MCs by CoS (case 5) or by size (case 4) yielded the same results, since there was no availability to retune.

The next interesting cases were 2 and 3. In case 2, the MCs were sorted by MC size. Case 3 sorted the MC by CoS. Both cases allowed transponders to retune to available spectrum upon fault, but did not drop any NMCs to fit into the spectrum. Both cases yielded better results than the previous Case 1, 4, and 5 in total MCs and NMCs restored, as well as higher priority NMC and MCs restored. This is likely due to the fact that MCs may be restored on any available spectrum. Case 3 restored higher priority NMCs and MCs (CoS= 5 and CoS=4) than Case 2. This

is any extremely important conclusion as it demonstrates that placing a CoS on the MC yields the expected results of prioritizing high priority traffic.

Cases 6 and 7 yielded the highest number of priority NMCs and MCs restored out of any of the cases. Case 6 also restored the highest number of total NMCs out of all of the cases. This finding demonstrates that incorporating both MC and NMC priority with retuning yields the best results. Case 7 restored the highest number of high priority NMCs out of any case presented, at the cost of reducing the number of total NMCs restored. This is because Case 7 putting NMC priority above all other priority.

Finally, the results indicate that employing a CoS scheme to the NMC and MCs favors higher quality traffic in the instance of a fault. By dropping lower quality NMCs through both protection and restoration schemes valuable traffic resources are saved. The selected protection approach ensures precious bandwidth is only reserved for high quality traffic, while still utilizing the benefits of MC and NMC to increase spectral efficiency. In restoration, Case 7 proved to restore the highest number of high priority NMCs, by only recognizing the NMCs CoS. However, Case 6 proved to restore a high number of high priority NMCs as well as other traffic. Case 6, is a more favourable solution since both the MC and NMCs CoS is considered when restoring traffic.

6.2 Future Work

There are many advancements and extensions that can be applied to the proposed protection and restoration schemes. In both protection and restoration, S-BVTs may be incorporated to squeeze the NMCs through bandwidth squeezing or slicing. As indicated in Chapter 2, there has been significant research in the area of BVTs. By employing the proposed protection and restorations schemes to also utilize sliceable BVTs, the spectrum efficiency and benefits of this technology are realized. Chapter 3 suggests including a bandwidth reduction flag in the network media channel identifier. This flag would indicate when a BVT equipment is utilized for the NMC.

The NMC would then have the opportunity to reduce pre-allocated protection resources or dynamic restoration capacity.

Another opportunity for advancement is to incorporate fragmentation aware routing and spectrum assignment schemes. Fragmentation imposes an immense challenge to EONs as traffic provisioning becomes more flexible than ever. The removal of fixed grid allocation creates a vulnerability to spectrum that is unusable. Unusable spectrum is spectrum between channels that is not sufficient for traffic to be provisioned. A significant amount of unusable spectrum, or fragmentation, fundamentally reduces the efficiency of the spectrum. Consequentially, fragmentation is a prominent research area due to the imposed challenges of flexible traffic provisioning. As discussed in Chapter 5, divided and mixed protection increased the fragmentation in the network. In restoration, Case 7 is also vulnerable to fragmentation since it divides the MCs into multiple NMCs. Incorporating a fragmentation aware spectrum assignment, routing scheme, or traffic grooming would greatly compliment the proposed protection and restoration techniques.

Finally, restoration may be further optimized in most occurrences. For instance, applying a higher priority to restoring traffic in the same spectrum would improve restoration times by avoiding transponder re-tuning. In Case 7, ideally the NMC restoration would be optimized by prioritizing the NMCs that are along the same source to destination path to be spectrally adjacent. This would allow larger MCs to be created, reducing the requirement for excessive MCs and consequently guard-bands. In both the protection and restoration schemes, spectrum assignment used was first-fit policy, for simplicity. Exploring other flexgrid spectrum assignment policies, which encourage spectral efficiency, would ensure that a greater amount of traffic is able to be restored.

References

- [AIB16] M. Aibin and K. Walkowiak, "Defragmentation algorithm for joint dynamic and static routing problems in elastic optical networks with unicast and anycast traffic," 2016 International Conference on Computing, Networking and Communications (ICNC), Kauai, HI, 2016, pp. 1-5.
- [CAS12] A. Castro et al, "Dynamic routing and spectrum (re)allocation in future flexgrid optical networks," *Computer Networks*, Vol. 56, 2012, pp. 2869–2883.
- [CAS14] A. Castro, "On the benefits of multi-path recovery in flexgrid optical networks", *Photonic Network Communications*, Vol. 28, pp. 251-263.
- [CHA17] B. C. Chatterjee, N. Sarma and P. P. Sahu, "Priority based routing and wavelength assignment with traffic grooming for optical networks," *IEEE/OSA Journal of Optical Communications and Networking*, Vol. 4, no. 6, June 2012, pp. 480-489.
- [CHE15] X. Chen et al, "Fragmentation-aware routing and spectrum allocation scheme based on distribution of traffic bandwidth in elastic optical networks," *IEEE/OSA Journal of Optical Communications and Networking*, Vol. 7, no. 11, November 2015, pp. 1064-1074.
- [CLO16] B. Clouet et al, "Networking Aspects for Next-Generation Elastic Optical Interfaces," *Journal of Optical Communications and Networking*, Vol. 8, 2016, pp. A116-A125.
- [CUG17] F. Cugini et al, "Dedicated protection with signal overlap in elastic optical networks," *IEEE/OSA Journal of Optical Communications and Networking*, Vol. 9, no. 12, December 2017, pp. 1074-1084.
- [EGO13] R. Egorov, "Next Generation ROADM architecture and design," 2013 Optical Fiber Communication Conference and Exposition and the National Fiber Optic Engineers Conference (OFC/NFOEC), Anaheim, CA, 2013, pp. 1-3.
- [FOG16] T. Foggi, and F. Cugini, "Signal overlap for elastic optical networks", *Journal of Lightwave Technology*, Vol. 34, 2016, pp. 3400-3410.
- [GER12] O. Gerstel et al, "Elastic optical networking: A new dawn for the optical layer?", *IEEE Communications Magazine*, 2012.
- [GON15] D. Gonzalez et al, "Framework and Requirements for GMPLS-Based Control of Flexi-Grid Dense Wavelength Division Multiplexing (DWDM) Networks", RFC 7698, November 2015.
- [GOS15] R. Goscien et al, "Protection in elastic optical networks", *IEEE Network*, Vol. 29, no. 6, 2015, pp. 88-96.

- [HAR06] J.M. Harris et al., "Liquid-Crystal Based Optical Switching", Optical Switching, Springer, Boston, MA, 2006.
- [HOR14] A. Horota, G. B. Figueiredo and N. L. S. d. Fonseca, "Routing and Spectrum Assignment Algorithm with Fragmentation Minimization in Elastic Optical Networks," 2014 Brazilian Symposium on Computer Networks and Distributed Systems, Florianopolis, 2014, pp. 436-442.
- [ILY03] M. Ilyas and H. T. Mouftah, "The Handbook of Optical Communication Networks", Boca Raton: CRC Press, 2003.
- [IMR18] M. Imran et al, "A survey of optical carrier generation techniques for terabit capacity elastic optical networks", IEEE Communications Surveys & Tutorials, Vol. 20, Issue, 1, 2018, pp. 211-263.
- [ITU-T12] ITU G.694.1 Spectral Grids for WDM applications: DWDM frequency grid, February, 2012.
- [JIN09] M. Jinno et al, "Spectrum-efficient and scalable elastic optical path network: Architecture, benefits, and enabling technologies", IEEE Communications Magazine, Vol. 47, Issue 11, 2009, pp. 66-73.
- [JU15] W. Ju et al, "Spectrum defragmentation in flexgrid optical networks using a genetic algorithm", International Journal of Communication Systems, Vol. 28, 2015, pp. 358-373.
- [LAB07] J. Labourdette and E. Bouillet, "Path Routing in Mesh Optical Networks", John Wiley & Sons, Ltd, October 2007, pp. 125-137.
- [LAN12] C. Lange, O. Bonneß and N. Leder, "Operator perspective on broadband network traffic evolution," 2012 38th European Conference and Exhibition on Optical Communications, Amsterdam, 2012, pp. 1-3.
- [LAY13] P. Layec et al, "Elastic optical networks: The global evolution to software configurable optical networks," Bell Labs Technical Journal, Vol. 18, no. 3, December 2013, pp. 133-151.
- [LAY18] P. Layec "QoS-aware protection in flexgrid optical networks," IEEE/OSA Journal of Optical Communications and Networking, Vol. 10, no 1, January 2018, pp. A43-A50.
- [LOP16] V. Lopez and L. Velasco, "Elastic Optical Networks: Architectures, Technologies, and Control (Optical Networks Book Series)", Berlin, Germany: Springer-Verlag, 2016.
- [LOR16] A. Lord et al, "Evolution from Wavelength-Switched to Flex-Grid Optical Networks", Elastic Optical Networks. Optical Networks. Springer, Cham, 2016.
- [MAL14] A. Malik and G. Hart, "The Evolution of Next-Gen Optical Networks: Terabit Super-Channels and Flexible Grid ROADMs Architectures", SCTE Cable-Tec Expo, 2014.

- [MAN18] H. Mangesius, D. Xue and S. Hirche, "Consensus Driven by the Geometric Mean," IEEE Transactions on Control of Network Systems, Vol. 5, no. 1, March 2018, pp. 251-261.
- [MAR15] R. Martinez et al, "GMPLS/PCE-controlled multi-flow optical transponders in elastic optical networks [Invited]," IEEE/OSA Journal of Optical Communications and Networking, Vol. 7, no. 11, November 2015, pp. B71-B80.
- [MAY14] A. Mayoral et al, "Migration steps toward flexi-grid networks," IEEE/OSA Journal of Optical Communications and Networking, Vol. 6, no. 11, November 2014, pp. 988-996.
- [MEL14] G. Meloni et al, "First demonstration of optical signal overlap," Photonics in Switching Conference, 2014, pp. NM4D-4.
- [MIT13] A. Mitra et al, "Effect of link margin and frequency granularity on the performance of a Flexgrid optical network," 39th European Conference and Exhibition on Optical Communication (ECOC 2013), London, 2013, pp. 1-3.
- [MOR13] M. S. Moreolo et al, "Bandwidth variable transponders based on OFDM technology for elastic optical networks," 2013 15th International Conference on Transparent Optical Networks (ICTON), Cartagena, 2013, pp. 1-4.
- [NAP15] A. Napoli et al, "Next generation elastic optical networks: The vision of the European research project idealist," IEEE Commun. Mag., Vol. 53, no. 2, Feb. 2015, pp. 152–162.
- [PAO14] F. Paolucci et al, "Multipath restoration and bitrate squeezing in SDN-based elastic optical networks [invited]," Photonic Network Communications, Vol. 28, 2014, Issue 1, pp. 45-57.
- [PED17] J. Pedro, "Designing transparent flexible-grid optical networks for maximum spectral efficiency [Invited]," IEEE/OSA Journal of Optical Communications and Networking, Vol. 9, no. 4, April 2017, pp. C35-C44.
- [PET17] A. Peters et al, "Key performance indicators for elastic optical transponders and ROADMs: The role of flexibility", Optical Switching and Networking, Vol. 25, 2017, pp. 1-12.
- [RAM10] R. Ramaswami, K. N. Sivarajan, and G. Sasaki, "Optical networks: A practical perspective", Morgan Kaufmann, 2010.
- [ROB97] S. Robinson, "Simulation Model Verification and Validation: Increasing the Users' Confidence", Proceedings of the 1997 Winter Simulation Conference, 1997, pp. 53-59.
- [ROU12] M, Rouse, "NSFNET", Retrieved from:
<https://searchnetworking.techtarget.com/definition/NSFNET>, September 2012.
- [ROS12] A. Rosa et al, "Spectrum allocation policy modeling for elastic optical networks," High Capacity Optical Networks and Emerging/Enabling Technologies, 2012, pp. 242-246.

- [SAI13] H. Saini, and A. Garg, "Protection and Restoration Schemes in Optical Networks: A Comprehensive Survey", International Journal of Microwave Applications, 2004.
- [SAM15] N. Sambo et al., "Next generation sliceable bandwidth variable transponders," IEEE Communications Magazine, Vol.53, 2015, pp.163,171.
- [SHA14] P. Sharma, A. Kumar and V. K. Sharma, "Performance analysis of high speed optical network based on Dense Wavelength Division Multiplexing," 2014 International Conference on Issues and Challenges in Intelligent Computing Techniques (ICICT), Ghaziabad, 2014, pp. 446-449.
- [SHE15] J. Shen, J. Chen and Y. Sun, "Fragmentation aware Routing and Spectrum Assignment algorithm for Elastic Optical Networks," TENCON 2015 - 2015 IEEE Region 10 Conference, Macao, 2015, pp. 1-4.
- [SHE16] G. Shen, H. Guo, and S. K. Bose, "Survivable elastic optical networks: survey and perspective," IEEE Photonic Network Communications, Vol. 31, no. 1, 2016, pp. 71–87.
- [SIM16] J.M. Simmons, "Optical Network Design and Planning", Springer, 2016.
- [SON11] Y. Sone et al, "Bandwidth Squeezed Restoration in Spectrum-Sliced Elastic Optical Path Networks (SLICE)", Journal of Optical Communications and Networking, 2011.
- [SOM06] Somani, A., "Survivability and Traffic Grooming in WDM Optical Networks", Cambridge University Press, 2006.
- [TAK09] M. Jinho, H. Takara, B. Kozicki, "Dynamic optical mesh networks: drivers challenges and solutions for the future", 35th European Conference on Optical Communication, 2009, ECOC'09, IEEE, 2009, pp. 1–4.
- [TAL14] S. Talebi et al, "Spectrum management techniques for elastic optical networks: A survey," Optical Switching and Networking, Vol. 13, 2014, pp. 34-48.
- [TAN15] T. Tanaka et al, "Subcarrier restoration for survivable multi-flow transponders in elastic optical networks," 2015 21st Asia-Pacific Conference on Communications (APCC), Kyoto, 2015, pp. 214-217.
- [VAS04] J.P Vasseur, M. Pickavet, and P. Demeester, "Chapter 3 - Optical Networks", The Morgan Kaufmann Series in Networking, Network Recovery, Morgan Kaufmann, 2004, pp 131-201.
- [VEL12] L. Velasco et al, "Modeling the routing and spectrum allocation problem for flexgrid optical networks", Photonic Network Communications, Vol. 24, 2012, pp. 177-186.

- [VEL13] L. Velasco et al, "Saving CAPEX by extending flexgrid-based core optical networks toward the edges [invited]," *IEEE/OSA Journal of Optical Communications and Networking*, Vol. 5, no. 10, October 2013, pp. A171-A183.
- [VEL17] L. Velasco, et al. "Restoration in the Optical Layer", *Provisioning, Recovery, and In-operation Planning in Elastic Optical Networks*, John Wiley & Sons, 2017, pp. 279-312.
- [WAL14] K. Walkowiak et al, "Routing and spectrum allocation algorithms for elastic optical networks with dedicated path protection", *Optical Switching and Networking*, Vol. 13, 2014, pp. 63-75.
- [WIL95] P. R. Wilson et al, "Dynamic Storage Allocation: A Survey and Critical Review," in *Proceedings of the International Workshop on Memory Management*, ser. IWMM '95. London, UK, UK: Springer-Verlag, 1995, pp. 1-116.
- [WU17] H. Wu et al, "On the Distance Spectrum Assignment in Elastic Optical Networks," *IEEE/ACM Transactions on Networking*, Vol. 25, no. 4, August 2017, pp. 2391-2404.
- [YEN70] J. Yen, "An algorithm for finding shortest routes from all source nodes to a given destination in general networks", *Quarterly of Applied Mathematics*, Vol. 27, Issue 4, 1970, pp. 526–530.
- [YEN71] J. Yen "Finding the K Shortest Loopless Paths in a Network", *Management Science*, Vol. 17, Issue 11, 1971, pp. 712-716.
- [ZHE04] J. Zheng, and H. Mouftah, "Optical WDM networks: Concepts and design principles", New York: Wiley, 2004.
- [ZHO00] D. Zhou, and S. Subramaniam, "Survivability in Optical Networks", *Network*, IEEE. 14. 16 - 23. Vol. 14 , 2000 , pp. 16-23.
- [ZYS02] J. Zyskind et al, "Chapter 5 - High-Capacity, Ultra-Long-Haul Networks", *Optical Fiber Telecommunications IV-B (Fourth Edition)*, Academic Press, 2002, pp. 226-227.