

## **INFORMATION TO USERS**

**This manuscript has been reproduced from the microfilm master. UMI films the text directly from the original or copy submitted. Thus, some thesis and dissertation copies are in typewriter face, while others may be from any type of computer printer.**

**The quality of this reproduction is dependent upon the quality of the copy submitted. Broken or indistinct print, colored or poor quality illustrations and photographs, print bleedthrough, substandard margins, and improper alignment can adversely affect reproduction.**

**In the unlikely event that the author did not send UMI a complete manuscript and there are missing pages, these will be noted. Also, if unauthorized copyright material had to be removed, a note will indicate the deletion.**

**Oversize materials (e.g., maps, drawings, charts) are reproduced by sectioning the original, beginning at the upper left-hand corner and continuing from left to right in equal sections with small overlaps.**

**Photographs included in the original manuscript have been reproduced xerographically in this copy. Higher quality 6" x 9" black and white photographic prints are available for any photographs or illustrations appearing in this copy for an additional charge. Contact UMI directly to order.**

**ProQuest Information and Learning  
300 North Zeeb Road, Ann Arbor, MI 48106-1346 USA  
800-521-0600**

**UMI<sup>®</sup>**





**Université d'Ottawa • University of Ottawa**



**DURATION OF ORAL ANTICOAGULATION IN FIRST EPISODE  
IDIOPATHIC DEEP VEIN THROMBOSIS:  
A Markov Decision Analysis**

by

**Melissa Anne Forgie**

Thesis submitted to  
the School of Graduate Studies and Research  
in partial fulfillment of the requirements for the  
MSc Degree in Epidemiology

University of Ottawa

January 2001



**National Library  
of Canada**

**Acquisitions and  
Bibliographic Services**

**395 Wellington Street  
Ottawa ON K1A 0N4  
Canada**

**Bibliothèque nationale  
du Canada**

**Acquisitions et  
services bibliographiques**

**395, rue Wellington  
Ottawa ON K1A 0N4  
Canada**

*Your file Votre référence*

*Our file Notre référence*

**The author has granted a non-exclusive licence allowing the National Library of Canada to reproduce, loan, distribute or sell copies of this thesis in microform, paper or electronic formats.**

**The author retains ownership of the copyright in this thesis. Neither the thesis nor substantial extracts from it may be printed or otherwise reproduced without the author's permission.**

**L'auteur a accordé une licence non exclusive permettant à la Bibliothèque nationale du Canada de reproduire, prêter, distribuer ou vendre des copies de cette thèse sous la forme de microfiche/film, de reproduction sur papier ou sur format électronique.**

**L'auteur conserve la propriété du droit d'auteur qui protège cette thèse. Ni la thèse ni des extraits substantiels de celle-ci ne doivent être imprimés ou autrement reproduits sans son autorisation.**

0-612-67818-0

**Canada**

**ABSTRACT**

**Background:** Deep venous thrombosis (DVT) of the lower extremity is a serious illness with an estimated incidence of 1 per 1000 persons per year. The course of this illness can be complicated by pulmonary embolism, which can be fatal and post-thrombotic syndrome, which can lead to debilitating morbidity. The goal of treatment with anticoagulant therapy is to minimize these outcomes. However, the optimal duration of anticoagulant therapy is unknown, as the literature to date is conflicting with durations of therapy ranging from three months to at least two years. Furthermore, anticoagulation therapy itself may lead to complications such as bleeding, which also can be fatal. There have been many previous studies on duration of therapy but these have reported on outcomes of recurrent venous thromboembolism, and bleeding and patient preferences have not been taken into account. In this context, decision analysis would allow the physician to consider all possible outcomes such as bleeding and recurrent thrombosis and account for patient preferences. This would enable the physician to choose the duration of therapy that maximizes benefit to the patient.

**Objectives:** To compare the lifetime risks and benefits of three months, six months, twelve months, two years, and lifelong anticoagulation for first episode idiopathic DVT. Secondary objectives were to assess quality of life for patients on warfarin therapy for DVT and for patients with post-thrombotic syndrome. A third objective was to determine if quality of life for these two health states differed between patients and healthy volunteers.

**Methods:** Decision analysis with a Markov model was used to simulate patients with first episode idiopathic DVT who would be treated with durations of therapy ranging from three months to lifelong. The probabilities of clinical events were extracted from a systematic review of the literature on duration of therapy for DVT as well as rates of bleeding secondary to anticoagulant therapy and rates of developing post-thrombotic syndrome. Utilities for each of the associated health outcomes were elicited from patients and healthy volunteers using a computerized interview.

**Results:** There are only two randomized trials on duration of anticoagulant therapy in first episode idiopathic DVT. Base-case analysis suggests that three months of therapy is the preferred strategy. Based on the best available evidence, three months of therapy was associated with an average life expectancy of 11.5809 years and an average quality adjusted life expectancy of 9.6525 years. Six months of therapy was associated with a life expectancy of 11.5730 years and a quality adjusted life expectancy of 9.6502 years. Twelve months of therapy was associated with a life expectancy of 11.5583 years and a quality adjusted life expectancy of 9.6502 years. Two years of therapy was associated with a life expectancy of 11.5331 years and a quality adjusted life expectancy of 9.6423 years. Lifelong therapy was associated with a life expectancy of 11.4287 years and a quality adjusted life expectancy of 9.6143 years. The magnitude of the differences between the strategies is small and the results of the analysis are sensitive to changes in the values of several key variables. The model is very sensitive to the utility of oral anticoagulant therapy such that depending on the perceived burden of oral anticoagulant therapy, the preferred duration changes from short term to lifelong. If the utility for oral anticoagulant therapy is less than or equal to 0.928, three months of therapy is preferred

while any utility greater than this results in lifelong therapy becoming the optimum strategy.

**Conclusion:** More studies are needed in order to compare the currently recommended durations of therapy for idiopathic DVT. In the only two completed randomized trials on duration of therapy in this patient population, outcomes such as intracranial hemorrhage, rates of post-thrombotic syndrome and death secondary to bleeding and PE did not occur. Thus these rates were derived from studies with populations who differed from the one of interest. Patient perception of the burden of oral anticoagulant therapy has a major impact on treatment duration choices. With the currently available rates, recommendations for duration of therapy for idiopathic DVT should be based on individual patient preferences, as treatment duration choices are highly sensitive to this variable.

## **ACKNOWLEDGEMENT**

I would like to thank my husband, Steve, and my children Chloe and Will. Steve's understanding about my prolonged absences from home, his support while establishing his own very demanding career and achieving partnership status in his law firm during all of this have been nothing short of extraordinary. My children, both of whom were born during the four years it took to complete my Masters degree, have always welcomed me home with open arms in spite of many hours spent away from them. Their unconditional love is truly what made this project possible.

As always, I would like to thank my parents for their endless support. I still strive in all of my endeavors to make them proud of me.

I would like to thank my supervisor, Dr. Graham Nichol, who taught me everything I know about decision analysis. His time, patience, incredible knowledge, and enthusiasm have been invaluable and have helped me to create a research niche that will last a lifetime. I would also like to thank my other supervisor, Dr. Phil Wells, who is my mentor and role model, and who has taught me everything I know about thromboembolic diseases. He is solely responsible for any success I have achieved in my career to date.

Many thanks also go to Drs Rama Nair and Robert Spasoff who have both been so understanding about my absences for not one but two maternity leaves and the huge time commitments incurred by my busy clinical and teaching practices.

I would also like to thank Ms Anjali Patel for her invaluable assistance with the collection of the utilities, Mrs. Marilyn Colley for her expertise in reference retrieval and

management, and Drs Alaa Rostom and Anne Cranney for producing the utility elicitation program.

**TABLE OF CONTENTS**

<b>ABSTRACT</b>	<b>II</b>
<b>ACKNOWLEDGEMENT</b>	<b>V</b>
<b>LIST OF TABLES</b>	<b>XI</b>
<b>LIST OF FIGURES</b>	<b>XII</b>
<b>LIST OF APPENDICES</b>	<b>XIV</b>
<b>INTRODUCTION</b>	<b>1</b>
<b>METHODS</b>	<b>7</b>
<b>1    Decision Analytic Model</b>	<b>7</b>
<b>1.1    Markov Model</b>	<b>7</b>
<b>1.2    Construction of the Model</b>	<b>8</b>
<b>1.2.1    Construction of basic model</b>	<b>8</b>
<b>1.2.2    Advanced modeling</b>	<b>10</b>
<b>1.3    Structure of the Model</b>	<b>11</b>
<b>2    Patient Population</b>	<b>16</b>
<b>3    Rewards</b>	<b>16</b>

		<b>VIII</b>
<b>4</b>	<b>Utilities</b>	<b>17</b>
	4.1 Respondent Population	17
	4.2 Sample Size for Elicitation of Utilities	18
	4.3 Response Scale	19
	4.4 Health State Descriptions	20
	4.5 Computer-based Interview	21
	4.6 Instrument Testing	22
	4.7 Hypothesis Testing	23
	4.8 Consent	24
	4.9 Disutilities	25
<b>5</b>	<b>Probabilities</b>	<b>25</b>
	5.1 Literature Search	25
	5.1.1. Probability of recurrent venous thromboembolism	25
	5.1.2. Probability of bleeding secondary to oral anticoagulants	27
	5.1.3. Probability of pulmonary embolism and fatal pulmonary Embolism after recurrent VTE	29
	5.1.4. Probability of post-thrombotic syndrome	30
	5.2 Data Abstraction	30
<b>6</b>	<b>Outcomes</b>	<b>32</b>
	6.1 Probability of recurrent VTE	32
	6.2 Probability of DVT or PE given recurrent VTE	34

6.3	Probability of major, fatal, and intracranial hemorrhage secondary to oral anticoagulant therapy	35
6.4	Probability of developing post-thrombotic syndrome	35
6.5	Probability of death secondary to PE after recurrent VTE	36
6.6	Probability of recurrent VTE while on lifelong OAC after a second episode of VTE	37
7	Assumptions	39
8	Uncertainty Analysis	41
8.1	Assessment for errors in the model	41
8.2	Assessment of robustness of results	42
8.3	Best and worst case scenarios	43
	<b>RESULTS</b>	44
1	Utilities	44
1.1	Respondents	44
1.2	Utility Values	44
1.3	Tests of hypotheses	45
2	Structural Integrity of Model	49
3	Base Case Analysis	50
4	Sensitivity Analyses	51
4.1	One-way analyses	51
4.1.1	Probability of major bleeding	52
4.1.2	Probability of moderate-to-severe post-thrombotic syndrome	52

4.1.3	Utility for being on oral anticoagulant therapy	53
4.1.4	Utility for moderate-to-severe post-thrombotic syndrome	54
4.1.5	Probability of recurrent VTE after a second episode of VTE on lifelong anticoagulant therapy	55
4.1.6	Utility for being off anticoagulant therapy	55
4.2	Two-way sensitivity analyses	58
4.3	Multi-way sensitivity analyses	59
4.4	Best case and worst case scenarios	64
<b>DISCUSSION</b>		66
<b>APPENDICES</b>		72
<b>REFERENCES</b>		90

**LIST OF TABLES**

<b>Table 1:</b>	<b>Literature search for randomized trials on duration of therapy for idiopathic DVT</b>	<b>27</b>
<b>Table 2:</b>	<b>Rates and probabilities of outcomes</b>	<b>37</b>
<b>Table 3:</b>	<b>Utility Estimates</b>	<b>44</b>
<b>Table 4:</b>	<b>T-test for independent samples</b>	<b>46</b>
<b>Table 5:</b>	<b>Mann-Whitney test</b>	<b>47</b>
<b>Table 6:</b>	<b>Repeated-measures analysis of variance</b>	<b>48</b>
<b>Table 7:</b>	<b>Friedman test</b>	<b>48</b>
<b>Table 8:</b>	<b>Base case results</b>	<b>51</b>
<b>Table 9:</b>	<b>Summary of one-way sensitivity analyses</b>	<b>56</b>
<b>Table 10:</b>	<b>Bias in favour of longer-term anticoagulation and shorter-term anticoagulation: comparison to base-case analysis</b>	<b>65</b>

**LIST OF FIGURES**

<b>Figure 1:</b>	<b>Markov model for duration of anticoagulation for first episode idiopathic deep vein thrombosis</b>	<b>12</b>
	<b>A. Decision node: treatment duration choices</b>	<b>12</b>
	<b>B. Markov health states</b>	<b>13</b>
	<b>C. Subtree for the state of being on oral anticoagulants</b>	<b>14</b>
	<b>D. Subtree for the state of being off oral anticoagulants</b>	<b>14</b>
	<b>E. Clones for treatment durations, recurrent VTE and bleeding</b>	<b>15</b>
<b>Figure 2:</b>	<b>Method for obtaining utilities using the standard gamble</b>	<b>20</b>
<b>Figure 3:</b>	<b>Markov probability analysis for lifelong anticoagulant therapy</b>	<b>50</b>
<b>Figure 4:</b>	<b>One-way sensitivity analysis on the probability of major bleeding</b>	<b>53</b>
<b>Figure 5:</b>	<b>One-way sensitivity analysis on the utility of oral anticoagulant therapy</b>	<b>54</b>
<b>Figure 6:</b>	<b>One-way sensitivity analysis on the utility of moderate-to-severe post-thrombotic syndrome</b>	<b>55</b>
<b>Figure 7:</b>	<b>Two-way sensitivity analysis on the probabilities of recurrent VTE on and off oral anticoagulant therapy</b>	<b>58</b>
<b>Figure 8:</b>	<b>Three- way sensitivity analysis of the effect of varying the probabilities major bleeding, recurrent VTE on anticoagulant therapy and the utility of oral anticoagulant therapy on the optimum strategy</b>	
	<b>A.</b>	<b>60</b>
	<b>B.</b>	<b>61</b>
	<b>C.</b>	<b>61</b>

**Figure 9:** Three-way sensitivity analysis of the effect of varying the probability of major bleeding and the utilities for oral anticoagulant therapy and moderate-to-severe post-thrombotic syndrome.

A.	62
B.	62
C.	63
D.	63

**LIST OF APPENDICES**

<b>Appendix 1:</b>	<b>Volunteer poster</b>	<b>72</b>
<b>Appendix 2:</b>	<b>Newspaper advertisement</b>	<b>73</b>
<b>Appendix 3:</b>	<b>Health Utilities Index (HUI) Mark III</b>	<b>74</b>
<b>Appendix 4:</b>	<b>Health state descriptions</b>	<b>77</b>
	<b>A. Perfect health</b>	<b>77</b>
	<b>B. Oral anticoagulant therapy</b>	<b>78</b>
	<b>C. Mild post-thrombotic syndrome</b>	<b>79</b>
	<b>D. Moderate to severe post-thrombotic syndrome</b>	<b>80</b>
	<b>E. Permanent neurologic sequelae secondary to intracranial hemorrhage</b>	<b>81</b>
<b>Appendix 5:</b>	<b>Sample of computerized standard gamble A - C</b>	<b>82</b>
<b>Appendix 6:</b>	<b>Respondent consent for utility collection</b>	<b>85</b>
<b>Appendix 7:</b>	<b>Research proposal approval</b>	<b>87</b>
<b>Appendix 8:</b>	<b>Search strategy for randomized trials on duration of therapy in deep vein thrombosis</b>	<b>88</b>
<b>Appendix 9:</b>	<b>Search strategy for bleeding secondary to oral anticoagulants</b>	<b>89</b>

## **INTRODUCTION**

Deep venous thrombosis (DVT) of the lower extremity is a serious illness and is estimated to occur in 1 per 1000 persons per year. The disease may occur in association with risk factors such as the post-operative state, trauma, active malignancy, pregnancy, or hereditary thrombophilias, but may also occur in their absence. The latter is referred to as idiopathic DVT (1). Patients with DVT may have the course of their illness complicated by pulmonary embolism (PE) which can be fatal, recurrent episodes of venous thromboembolism (VTE), and post-thrombotic syndrome, that may lead to venous ulceration, debilitating pain and refractory edema.

Heparins and then oral anticoagulants are administered in order to minimize these complications. However, the optimal duration of oral anticoagulation in patients with idiopathic DVT is unknown (1-3). Traditionally, patients with their first episode of idiopathic DVT have been treated with three months of anticoagulation therapy (1). However, other recommendations for duration of therapy have varied from four weeks to six months (4-9). Two recently completed randomized clinical trials have further complicated the situation by producing directly conflicting results (15,16). The first concluded that at least two years of anticoagulation might be indicated in these patients (15). Since it is not clear if even two years will be sufficient therapy, some physicians wonder if lifelong therapy would be more appropriate. However, the second study concluded that one year of therapy is sufficient and that the advantage observed at one year is not sustained at two years (16). Thus, as a result of these and previously published conflicting studies, there is likely to be ongoing practice variation (6,9,17,18).

Furthermore, although outcomes such as rates of bleeding have been well studied in these trials, the health-related quality of life associated with these outcomes has not been addressed well. The decision to recommend long term anticoagulation is often difficult because the risk of recurrent VTE may not exceed the risk of major hemorrhage, and for some patients, the prospect of prolonged warfarin therapy with the necessary lifestyle limitations is daunting. A second issue is the risk of developing post-thrombotic syndrome. This is a disabling complication of DVT (20-23) and is more common among patients with recurrent DVT (23,27). Thus a major benefit of prolonged therapy may be a reduction in the frequency of this condition. Decision analysis in this context will therefore allow the physician to maximize patient well being by choosing the treatment duration that provides the highest quality of life.

Decision analysis is a method of comparing alternatives such as duration of anticoagulation by accounting for multiple events such as death, bleeding or recurrent thromboembolism. Decision analysis allows one to subdivide a complex problem into components small enough to be understood and therefore analyzed. By listing all possible decisions and outcomes, the physician is then able to identify the sequence of decisions that maximizes benefit to the patient.

Probability, expected value decision, and utility are the fundamental concepts of decision analysis (28). Probability is the likelihood that an event will occur. Expected value decision making is the concept of choosing the decision, which on average achieves the best outcome. This is achieved by choosing among competing alternatives by defining the associated events, assigning probabilities and values to each event and then calculating the expected value of each alternative by multiplying probability by value and

adding the result. The best alternative is whichever has the greatest expected value (assuming that greater is better).

Utility is becoming an increasingly used outcome measure in the assessment of health-care. This is largely due to recent emphasis on consideration of quality of life. While an assessment of quality of life can be obtained through discussion with a patient, utility collection offers a systematic approach to understanding a patient's perspective. Utility analysis therefore allows for unbiased and explicit consideration of patient values (28). Utility refers to an individual's subjective preference when choosing among alternatives under uncertainty.

A utility score is a cardinal measure of the relative desirability of a given health state as reported by an individual (29). The score can range from 1, considered to represent perfect health, to 0, which represents death. Scores of less than 0 can be achieved, and represent states considered to be worse than death.

Previous decision analyses on duration of anticoagulation for DVT have been published (30,36,37,39-42). However, each has major limitations. In the first study (30), it is unclear whether the patients under consideration had idiopathic DVT, recurrent DVT or secondary DVT. This is important clinically as rates of recurrence of DVT vary between these patient populations (9,17,31,32). Furthermore, rates and probabilities used in the baseline analysis were based on articles published before 1993 and do not reflect the current more accurate rates of VTE and bleeding (34). Widespread use of the INR for anticoagulation has since occurred and low molecular weight heparin is the more commonly used drug in the acute period (34). In addition, other probabilities such as the probability of PE following DVT included symptomatic and asymptomatic PE together,

although these have different rates of death and differences in clinical significance (35). The utilities that were used were not described in any detail and the study did not consider quality of life on oral anticoagulation therapy or post-thrombotic syndrome.

The second study and third studies (36,37) only considered patients with the factor V Leiden mutation who may have a higher risk of recurrent DVT when compared to non-carriers (38).

The fourth and fifth studied patients with deficiencies in antithrombin III, protein C or protein S, who may also have an increased risk of recurrent venous thromboembolism compared to patients without such a deficiency. These studies also used rates based on small numbers of patients (39,40).

A sixth decision analysis used some studies that did not use objective testing in order to derive baseline estimates of risk as well as considering mixed populations of patients in terms of risk of recurrent VTE (41). A simple model was used, the assumptions were not stated and no utilities were collected or considered. The study did not take into account the data from the WODIT trial, which is one of only two trials that have studied patients with idiopathic DVT exclusively (16). The authors concluded that the results were very sensitive to small changes in the baseline estimates such that their accuracy would play a major role in the analysis, which further supports why only studies of good methodologic quality should be used. The authors also concluded that the impact of non-fatal events (such as quality of life for post-thrombotic syndrome) should be taken into account as sensitivity analysis demonstrated that small effects on quality of life strongly influence the optimal duration of treatment.

The seventh decision analysis distinguished between patients with transient risk factors and those who did not have these risk factors (42). It is not clear if the latter group included patients with thrombophilias or not, nor is it clear if patients with idiopathic DVT were considered at all. Furthermore, the studies from which baseline estimates were obtained did not all use objective testing. Utilities for the various health states were not assessed because the authors concluded that inclusion of utility estimates for these health states would not change the optimal duration for therapy dramatically. As well, the authors assumed that patients are unlikely to trade life-time for the burden of post-thrombotic syndrome. This conclusion is based on a decision analysis by O'Meara et al (43), which demonstrated that patients assigned relatively high utilities for post-thrombotic syndrome (mean of 0.982 for severe post-thrombotic syndrome). However, this study interviewed only 36 patients and did not use standardized descriptors to describe the various health states. A study by Lenert et al demonstrated that healthy volunteers had a median utility of 0.95 for severe post-thrombotic syndrome (44). This means that half of the subjects were willing to take more than a 5% risk of death to avoid life with severe post-thrombotic syndrome. The study used mostly female respondents who were between the ages of 20 and 40. An unpublished pilot study of 50 healthy volunteers performed at the Ottawa Hospital has demonstrated a mean utility of 0.799 (SD 0.196) for moderate-to-severe post-thrombotic syndrome, which demonstrates that individuals are indeed likely to trade life-time to avoid the burden of post-thrombotic syndrome. However, the utility of post-thrombotic syndrome in patients themselves has not been studied and the utility for oral anticoagulation in patients being treated for DVT has never been collected.

A study by Gage et al has demonstrated a utility of 0.997 for warfarin therapy but used primarily elderly white men, all of whom had atrial fibrillation and of whom over half were already taking warfarin (45). It is not clear if the utility for warfarin therapy in a different population would be the same. For example, younger patients may be more prepared to accept risks to gain health benefits (or minimize side effects) than older subjects are (46). The mean age of patients presenting with a first episode idiopathic DVT is 59 years (34).

Some authors have suggested that utility for a given health state is affected by the respondent's current state of health (47-50). Thus, it would be important to elicit a utility specific to this type of patient, in addition to the collection of such a value from healthy volunteers (48).

## **OBJECTIVES**

The objective of this thesis was to compare the lifetime risks and benefits of three months, six months, twelve months, two years, and lifelong anticoagulation for first episode idiopathic DVT by using decision analysis. Secondary objectives were to assess quality of life for patients on warfarin therapy for DVT and for patients with post-thrombotic syndrome. A third objective was to determine if the quality of life for these two health states differed between patients and healthy volunteers.

## **METHODS**

### **1.0 Decision Analytic Model:**

#### ***1.1 Markov model***

A Markov process is a modeling technique that describes the transitions a cohort of patients make among a number of health states during a series of short intervals or cycles. A Markov model was used for several reasons. First, it allows for incorporation of variation in transition probabilities over time. This is important because the risk of bleeding as a result of anticoagulant therapy (27,55) and the risk of recurrence of DVT vary over time (56,57,58). Second, the events in this decision analysis may occur repeatedly over time. Third, events may also may occur over a prolonged time such that death due to intercurrent illness may be a factor (12,59). A conventional decision tree requires that the analyst uses an explicit length of time but life expectancies of individuals vary. Fourth, a Markov model allows for assessment of incremental utility (59). An incremental utility is the relative value of occupying a given state for one cycle. Multiplying this value by the fraction of the cohort that occupies the given state and then summing across all of the possible states will then generate the total incremental utility generated by the cohort for a given cycle. The cumulative utility is then the sum of total incremental utility generated during each cycle. However, as the number of cycles increases, more of the members of the cohort die and therefore leave fewer to generate incremental utility (12). The process is terminated when all of the individuals reach the dead state. This allows for the treatment option of lifelong anticoagulation to be considered.

A Markov process also allows one to consider discounting for time preferences.

Most individuals would be less concerned about an adverse event that might occur in the future as opposed to one that might occur immediately. This is the process of discounting. Thus the value of utilities and disutilities should decrease over time.

A Markov process also differs from conventional decision trees by examining transitions during a series of cycles rather than considering health-state transitions over a fixed time period (12). A Markov model has four components: 1) structure which consists of a list of states and the transitions for each state, 2) probabilities, 3) rewards (costs, or in this case, patient utility), and 4) a termination condition (a test performed at the end of each cycle to determine if the process should continue calculating) (28).

## ***1.2 Construction of the model***

### ***1.2.1 Construction of basic model***

The stepwise approach described by Beck and Pauker (12) was used as follows:

a) enumeration of all distinct states of health (Markov health states): i) well, no anticoagulation, ii) receiving anticoagulant therapy, iii) on anticoagulation after recurrent VTE, iv) on anticoagulation with post thrombotic syndrome, v) off anticoagulation with post thrombotic syndrome, vi) recurrent VTE, vii) hemorrhage secondary to anticoagulants, and viii) dead. The states of hemorrhage and recurrent VTE are both temporary states and require transition into another state in the same cycle. The state of hemorrhage was further subdivided into one resulting in long term morbidity secondary to an intracranial hemorrhage, death due to hemorrhage, both of which are permanent states, and minor hemorrhage, which is a temporary state and required transition into

another state in the same cycle. The state of recurrent venous thromboembolism was subdivided into PE (which may result in death) or DVT. Hypothetical patients with recurrent VTE who do not die from PE were subsequently treated with lifelong anticoagulation, which is a permanent state (61). The eight states were mutually exclusive and capable of being ranked in order of least desirable to most desirable. At the end of a given cycle, a patient may remain in his current health state or move into one of the other possible Markov health states according to the probability of entering that given state which is based on rates extracted from the literature.

b) definition of allowable state transitions: All possible state transitions were allowed except for transitions from “dead” and transitions from longer term anticoagulation to shorter term therapy (i.e. from two years to 3 months, lifelong to 1 year, and so forth).

c) assignment of probabilities to the state transitions: The probabilities were abstracted from the clinical literature. MEDLINE databases, bibliographies and personal files were searched for these probabilities.

d) choice of cycle length: A cycle length of 3 months was chosen. A previously published decision analysis used cycles of one-week (30). However, the treatment durations that were considered ranged from 6-24 weeks. Such durations are no longer relevant as three months is now considered the minimum duration of anticoagulation (1). A cycle larger than 3 months might not be sensitive to the relatively small transition probabilities of some states.

The recommendations of Detsky were adhered to as follows: i) The tree was balanced such that none of the treatment duration options carried all of the risks and none

of the benefits; ii) The tree had symmetry (62). Symmetry is the process by which all initial states are represented in all branches. This was achieved by repeating portions of the various branches using subtrees. The subtree probabilities and utilities were then varied according to the different treatment strategies by using temporary bindings at points to the left of the subtree that altered these variables for that given strategy alone. Temporary bindings are reassigned values of estimates for given variables that override the global values. For example, the probability of recurrent VTE for each treatment strategy was assigned a temporary binding so that the probability was specific to the duration of therapy in question alone. Global values are estimates for the variables that are applied throughout the tree except where temporary bindings come into play. These values were stated at the main treatment decision node.

### *1.2.2 Advanced modeling*

Basic models require that transition probabilities remain constant with time. However, this does not reflect the natural history of venous thromboembolism. Tables were used to implement time-varying probabilities (63). These were incorporated into the model by creating probability expressions rather than using fixed values. Thus, wherever the model was given one of these expressions, the expression was evaluated at each new cycle. The corresponding value from appropriate tables (for example a table of probabilities of death due to unrelated causes) would then be inserted for the appropriate cycle.

The transition from one treatment to another is usually dictated by transition probabilities built into the model. Thus, in standard tree structures, a treatment

alternative is selected by examining the expected value of each treatment and selecting the one with the optimal path. It is however possible to “force” a treatment choice in Markov models. This process allowed the model to examine all of the treatment duration strategies. Logic nodes were used to force the model to discontinue anticoagulant therapy in patients who had reached the completed time of therapy for a given treatment duration.

The model also incorporated expressions to allow for events that occurred by a specific time and then were unlikely to occur thereafter. This “condition function” was used to model the outcome of post-thrombotic syndrome as most patients develop this disorder within two years of the initial DVT (27,64). This prevented the model from continuously incorporating the chance of developing this disorder beyond the anticipated time of presentation.

### ***1.3 Structure of the model***

The structure of the model is presented in Figure 1. The decision node (clear square) at the root of the tree then leads to each of the different treatment duration choices. At the beginning of the first cycle, all patients are receiving an initial 3 months (minimum recommended duration of therapy) of anticoagulation for a first episode of idiopathic DVT (65). Each of the treatment duration choices may then lead to all of the possible health outcomes, represented by subtrees. The subtrees all have identical structure (symmetry) but differ in the probability of each event according to the treatment duration.

**Figure 1: Markov model for duration of anticoagulation for first episode idiopathic deep vein thrombosis**

**A: Decision node: treatment duration choices**

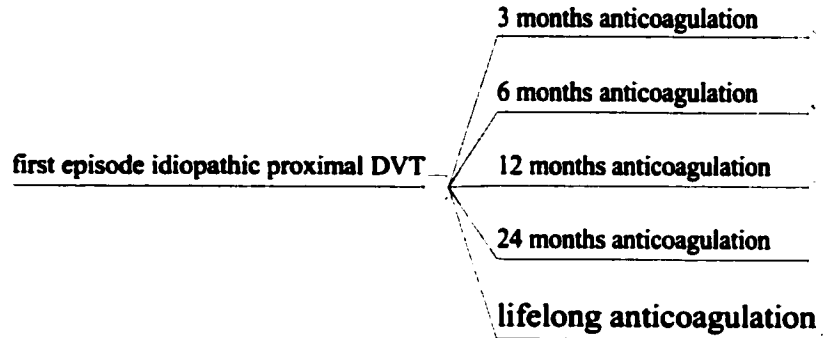

**Fig. 1A:** The decision node (square) represents the duration of anticoagulation choices for patients with first episode idiopathic DVT. Each treatment duration choice then leads to the possible Markov health states (round node with letter M).

## B: Markov health states

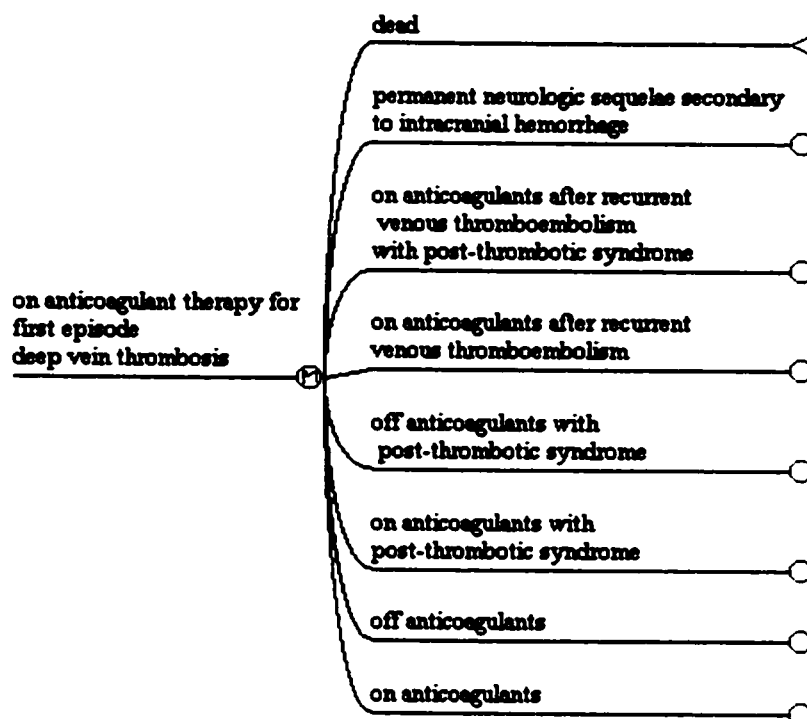
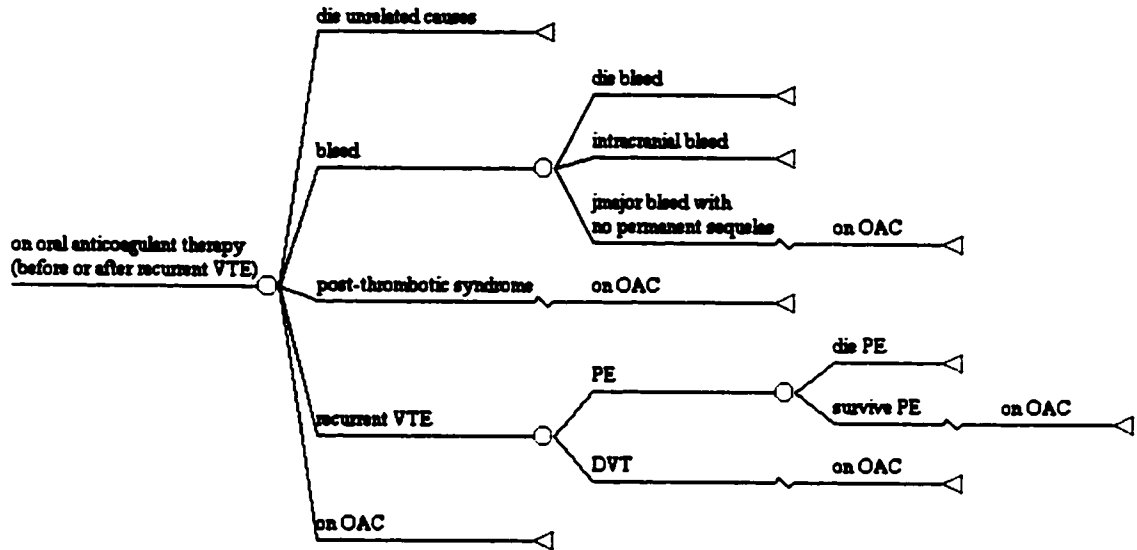
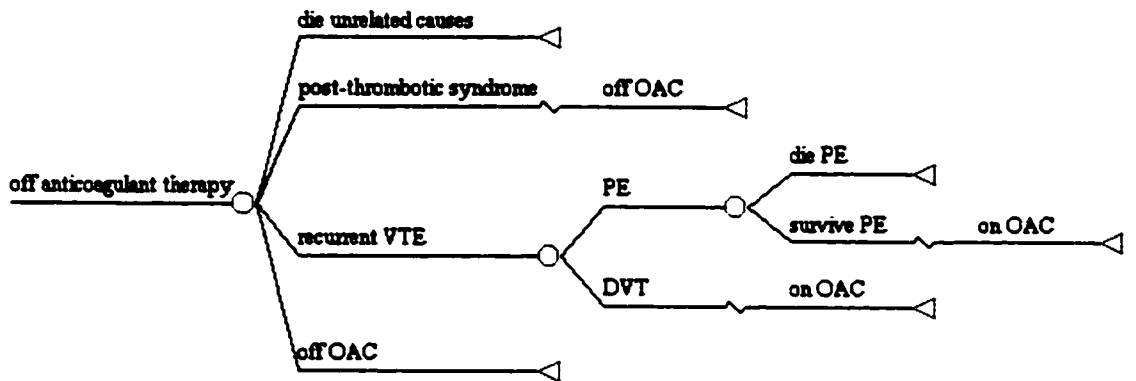

Fig. 1B: The Markov health states lead to subtrees, which represent the possible health outcomes of each Markov health state. At the beginning of the first cycle of three months, all patients are in the “on anticoagulants” state. At the end of the cycle, the patients are then redistributed among the Markov health states according to the probabilities of each event. The state of death is called the “absorbing” state, which terminates the Markov process. The process continues until the entire cohort enters the absorbing state.

**C: Subtree for the state of being on oral anticoagulants**



**D: Subtree for the state of being off oral anticoagulants**





## **2.0 Patient Population**

The conventional way to analyze a Markov model is to use cohort simulation (63). In this manner, a hypothetical cohort of patients is run through the model and examined probabilistically. The cohort in this analysis consisted of patients of either gender presenting with a first episode of idiopathic DVT. The cohort was followed until the entire cohort reached death and the cycle-specific incremental utility approached zero. The mean age of initial presentation (“start age”) was 59 years which was extracted from the only published randomized trial examining duration of therapy in first episode idiopathic DVT (15).

## **3.0 Rewards**

An assignment of value in a Markov model is referred to as a reward. These are accumulated during each cycle. The rewards that were examined in this analysis were life expectancy or life years (LY), quality adjusted life expectancy (QALY), and discounted quality adjusted life expectancy (discounted QALY). These rewards were labeled as payoffs 1, 2, and 3 respectively for the purposes of the model. As the output of each analysis was in terms of cycles (3 months duration), the value derived was divided by four in order to obtain LY, QALY, and discounted QALY.

In order to adjust life expectancy for quality of life, the measure of the subjective value of each year spent in a given health state is required. The length of expected life is then multiplied by the measure of the patient’s quality of life (28). This measure of quality of life is represented by the utility. Discounted quality adjusted life expectancy was examined in order to reflect that individuals prefer desirable outcomes to occur

earlier and undesirable outcomes to occur later (66). A rate of 3% was used based on the recommendations of the US Panel on Cost-Effectiveness in Health and Medicine (67). Estimates of mortality from unrelated causes were based upon the Declining Exponential Approximation of Life Expectancy (DEALE) method (33,68). This method makes use of the fact that, if population survival follows a declining exponential curve, then average mortality can be calculated as the reciprocal of life expectancy. General population life expectancy by age and sex were then taken from vital statistics data.

DATA 3.5® (TreeAge, DATA version 3.5; TreeAge Software Inc., Boston, MA) software was used for the modeling and analysis.

#### **4.0 Utilities**

##### ***4.1 Respondent population***

Utilities reflect the subjective judgement of individuals. Therefore, the choice of who to measure may have considerable impact on the conclusions of the study. There are many conflicting recommendations as to whether patients or healthy volunteers are more useful (69). This largely depends on what the aim of the study is. If cost-effectiveness is the major focus, then healthy volunteers should be used as the public bears the cost associated with health care resource allocation. On the other hand, the argument that patients who are currently experiencing the health states in question are more appropriate is also valid. These individuals are the only ones who truly know what it is like to be in those states and are presumably the only ones able to express “true” preferences. Some studies have found differences between patient and public preferences and others have not. It is reasonable to consider that patients would probably produce higher values for a

given health state than a healthy volunteer because people in poor health are often able to adapt to their condition (70,71). However, if one is seeking to reassure the public about treatment of a feared health state, then this should be the source of the utility (72). In view of this conflict, preferences were elicited from both healthy volunteers and patients.

Patients from the Ottawa Hospital Thrombosis Unit were recruited for the study. Inclusion criteria were the following: age greater than 18, history of idiopathic DVT, on oral anticoagulants for a minimum of three months, and able to give informed consent. Where possible, patients with a mean age of 59 (+/-16), based on the mean age of the LAFIT cohort (15) were recruited.

Volunteers were recruited through advertising at local community centers, retirement homes and clinics throughout the Ottawa Hospital. Posters were placed in central areas of these facilities (Appendix 1). Additional volunteers were recruited by placing an advertisement in the local paper (Appendix 2).

#### ***4.2 Sample size for elicitation of utilities***

A convenience sample of 80 respondents was selected. Fifty patients and 30 volunteers were interviewed. This sample size exceeds those of the majority of previously published studies on utility collection as convention has been to use a sample size of 30-50 for utility collection for a given health state. Utilities from patients and volunteers were pooled if T-tests, or in the case of non-normally distributed values, Mann-Whitney tests, indicated there was no difference between the utilities for these two groups (W. Furlong-personal communication) (74).

### ***4.3 Response scale***

The standard gamble (SG) method was used to measure the utilities. This is considered to be the most valid response scale for eliciting utilities because of its basis in economic theory (29) and utility theory (75,76). The scale asks participants to balance the prospect of remaining in the health state of interest against a gamble between a chance of perfect health and a complementary chance of immediate, painless death. This technique places the participant in a situation that obliges him to make a trade, which is similar to the situation in which an individual makes a health care decision. Therefore, the SG offers a choice between living in the health state in question, choice B, or taking a gamble between perfect health (probability of  $p$ ) and immediate death (probability of  $1-p$ ), choice A (Figure 2). The probability  $p$  is varied using a ping-pong approach until the respondent is indifferent between the health state in question and the gamble. An example health state would be one in which an individual is asked to evaluate the state of complete blindness. The respondent would then consider the highest risk of immediate death he/she would accept to achieve perfect health with no visual impairment. A possible response might be a 25% risk of death to avoid blindness. If one assumes that the utilities of immediate death and perfect health are 0.0 and 1.0, respectively, the utility of blindness would then be 0.75.

**Figure 2: Method for obtaining utilities using the standard gamble**

Imagine you have been diagnosed with condition X. There is a choice between two alternatives:

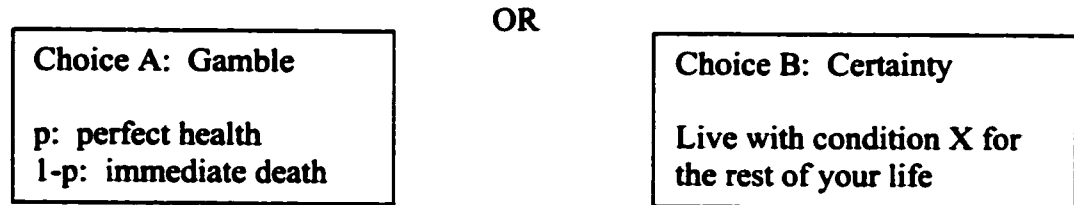

Fig. 2: The standard gamble requires that the probability ( $p$ ) is decreased systematically from a 100% chance of perfect health until the respondent is unable to decide between the certainty of life in condition X and the gamble.

There are other response scales for measuring utilities. These include the time trade-off method, the visual analogue rating scale and the willingness-to-pay technique. The time trade-off technique asks respondents to compare combinations of quantity and quality of life and is a proxy method for the SG (29). The willingness-to-pay technique asks respondents to compare combinations of quality of life and quantity of money, which is best reserved for assessment of brief events (77). The visual analogue scale does not produce cardinal utility measures. Thus, the SG is the method of choice and is considered to be the “gold standard” method (29).

#### ***4.4 Health state descriptions***

A computer-based multi-media interactive instrument was developed to measure all four permanent state utilities (78). Elicitation of utilities for the permanent states was prospective and included healthy volunteers as well as patients. The descriptions of the health states were based on the multiattribute utility function approach (29) using

descriptors from the Health Utility Index (HUI) Mark III (79) to frame the health states in order to ensure that they would be described in a uniform manner. The HUI Mark III was chosen because it has been validated in the North American population and it is being increasingly used for disease-specific utility collection (80). This index uses eight health domains, each with varying of degrees of impairment, to determine an overall health score (Appendix 3). For each of the scenarios, a brief text, describing the health state in question, was also provided. Diagnosis, disease labels and prognosis were not included in the descriptions as they have been shown to introduce bias into utility collection (81). The minimum possible number of attributes and the use of colour coding to highlight differences among the states were used in order to reduce cognitive burden (29). The content of the text was written in the second person singular and “RightWriter” software (version 3.0) was used to ensure the text was appropriate for an individual with a grade eight education (Appendix 4). Each of the descriptive scenarios and the descriptors selected from the HUI Mark III to reflect the health impairment of the states was independently reviewed by experts in the appropriate fields (P.W., G.N., M.F., P.S., P.B.).

#### ***4.5 Computer-based interview***

It has been demonstrated that computer-based multimedia health state descriptions improve respondent’s understanding of hypothetical health states when compared to conventional methods (82). A computer-based instrument allows for questions to be posed in an unbiased manner and ensures that questions are consistently asked in the same manner. It is convenient and well accepted by respondents (44). The

interviews for the utility collection were therefore conducted using a multimedia PC with the Windows 98® operative system. Images of the screen presentations are shown in Appendix 5. The standard gamble itself was presented in the converging “ping pong” method as proposed by Furlong et al (29). The use of a computer thus allowed for verbal, visual and written display of information (29). A laptop computer was used in order to ensure portability of the props required to conduct the interview and to minimize the inconvenience of travel for patients and volunteers. A research assistant was present during all of the interviews to ensure the respondent understood the questions and to assist in the use of the computer if needed.

#### ***4.6 Instrument testing***

The interview process was pilot tested in ten volunteers. The volunteers were asked to comment about the ease of use of the instrument and their general impressions. The failure rate of the interview was assessed by determining the fraction of subjects for whom the assessed utility of binocular blindness exceeded that of monocular blindness (83). The use of the example of binocular and monocular blindness provided an easily understood health state in which to test the respondents’ understanding of the standard gamble process. If the respondent was able to give a lower utility to binocular blindness, he or she was then asked to use the standard gamble to elicit the utilities for the four health states of: oral anticoagulant therapy, mild post-thrombotic syndrome, severe post-thrombotic syndrome, and permanent neurologic damage as a result of intracranial hemorrhage. The order of presentation of the health states was the same for all respondents and occurred in order of progressively less desirable health states. Face

validity was therefore assessed by determining if the respondents were able to demonstrate ranking of the outcome states (10). The results of an individual respondent were considered to be valid if the outcome of mild post-thrombotic syndrome was given a higher utility than severe post-thrombotic syndrome and the utility of permanent neurologic sequelae was given the lowest value of all of the health states in question.

#### ***4.7 Hypothesis testing***

The utility for each of the health states in question was determined by calculating the mean value for each. For the utility of each health state in the decision analytic model, the mean utility was then used as the “best estimate”. Ninety-five percent confidence intervals were used as the upper and lower estimates. Ranges for sensitivity analyses were derived from the range of values for the utility of each health state in the decision analytic model (29).

Two hypotheses were tested. The first hypothesis was that there was no difference between the mean utilities obtained for each of the scenarios, X, Y, Z, and Q. Thus the null hypothesis was  $\mu_X = \mu_Y = \mu_Z = \mu_Q$ . The alternate hypothesis was therefore that there was at least one mean utility that did equal another mean utility.

The second hypothesis was that there was no difference between the mean utilities for healthy volunteers and patients. Thus the second null hypothesis was  $\mu_H = \mu_P$ . The alternate hypothesis was that there was a difference between the two population means.

Analysis of variance was used to test the first hypothesis (29). The sources of variation were the utilities themselves, the within-respondent variation, the between-respondent variation and random error. Multivariate analysis of variance on the effect of

the scenario on the utility variable was performed. Thus, four observations were made on each patient and each volunteer. The utility value obtained represented the “observation”, the dependent variable, and the “treatments” were each of the scenarios. If the utility values for a given health state were not symmetrically distributed, the non-parametric Friedman test for samples of repeated measurements was used to test the null hypothesis, (W. Furlong-personal communication) (74).

A two-tailed t-test for equality of means for independent samples was used to test the second hypothesis (29,60). Both tests used a type I error rate of 0.05. In the event that the utilities were not symmetrically distributed, the Mann-Whitney test was used to test this hypothesis (W. Furlong-personal communication) (74).

Median values for the utilities were also calculated and used in the sensitivity analysis in case some of the values were not symmetrically distributed (W. Furlong-personal communication) (84).

All statistical analyses were performed using SPSS® 10.0 for Windows software.

#### ***4.8 Consent***

Signed written consent was obtained for each respondent (Appendix 6). The interview process and the descriptive scenarios were reviewed and approved by the Ottawa Hospital Research Ethics Board (Appendix 7). All information received during the interviews was kept confidential and respondents were identified by a study number alone. Aggregate data only were used such that individual responses were unidentifiable.

#### **4.9 Disutilities**

Utility values for the short-term health states of recurrent VTE on anticoagulants, recurrent VTE off anticoagulants and major bleed with no permanent sequelae were converted into disutility values (10). The disutility of a health state reflects the negative impact on quality of life associated with the state. The disutility of each of the temporary health states was calculated using the assumption that the quality of life spent in one of these short term health states was zero during the time spent in the given health state (68). Therefore, the quality of life for the health state of recurrent VTE off anticoagulants was set at zero for two weeks to reflect the time spent re-instituting oral anticoagulant therapy and the time to reach steady state. The time spent in the state of recurrent VTE on anticoagulant therapy was assumed to be of eight weeks duration, reflecting the use of heparin for the first six weeks and the subsequent re-introduction of oral anticoagulants until steady state is reached again. The duration of the state of a major bleed was assumed to be four weeks, reflecting a two-week period off anticoagulant therapy and two weeks to resume oral anticoagulants, including overlapping with heparin and the time to reach steady state dosing of oral anticoagulants.

#### **5.0 Probabilities**

##### ***5.1 Literature search***

###### ***5.1.1 Probability of recurrent venous thromboembolism***

A MEDLINE search of the database from 1966-October 2000 was performed in order to identify all randomized controlled trials on duration of therapy for idiopathic DVT. The subject headings: venous thrombosis, deep vein thrombosis, thrombophlebitis,

therapy, therapeutics, and randomized controlled trials were used. The “explode” function that further broadened the search to synonymous subject headings was applied to each term and each subject was also searched as a keyword. The search strategy yielded 806 articles (Appendix 8). Studies were excluded if they were review articles, trials using low molecular weight heparin or thrombolytics, or if they studied other thrombotic conditions such as stroke, prosthetic valves and so forth. Letters to the editor and editorials were also excluded as were studies looking at calf vein thrombi only. Studies on duration of therapy in patients with thrombophilias or secondary causes of DVT only and studies looking at low dose warfarin (studies not aiming for an INR of 2-3) were also excluded. Eight hundred and one articles were therefore excluded which left 5 randomized controlled trials on the duration of anticoagulation in DVT (5,15,17,32,61). The bibliographies of these articles were then reviewed which produced two more studies (18,85). Abstracts from meetings of The American Society of Hematology and The International Society of Hemostasis and Thrombosis for the last two years were reviewed which produced one more trial (16), and the DOTAVK study. Finally personal files were reviewed which produced three additional studies for a total of 12 studies (Table 1) (6,7,9). The study by Schulman et al was then excluded because the patient population consisted of those who presented with their second episode of VTE (61). Fennerty’s review published in the British Medical Journal was excluded because it was a review of previous randomized controlled trials (7). Five studies were excluded because objective testing or Doppler imaging were not used to confirm recurrent VTE (5,6,9,18,85). The DOTAVK study was excluded because no data was available in spite of efforts to correspond with the principal investigators. Thus a total of four studies were considered

for final data abstraction (15-17,32). Two of these studies looked only at patients with first episode idiopathic DVT (15,16). The others included other causes of DVT such as DVT secondary to trauma or malignancy in addition to patients with idiopathic DVT (17,32); thus they were also excluded.

In summary, estimates of rates of recurrent VTE were derived from two randomized trials of duration of anticoagulation therapy in idiopathic DVT (15,16).

**Table 1: Literature search for randomized trials on duration of therapy for idiopathic DVT**

1	Computerized database	806
2	Exclusion of review articles, letters to the editor, editorials, low molecular weight heparin trials or thrombolytic trials, conditions other than proximal idiopathic DVT	5
3	Bibliographies of above articles	2
4	Abstracts from ASH and ISTH	2
5	Personal files	3
	TOTAL	12

### *5.1.2 Probability of bleeding secondary to oral anticoagulants*

Bleeding rates were extracted from the two randomized trials on duration of anticoagulation in first episode idiopathic DVT which were used to obtain the rates of recurrent VTE. Bleeding was typically divided into major, according to the criteria of Levine et al, or minor if it was overt but did not meet the other criteria for major bleeding

(86). The risk of death due to bleeding was also obtained from these studies and where included, also the rate of intracranial hemorrhage. Since neither one of the trials had any episodes of intracranial hemorrhage or death secondary to bleeding or did not report on these outcomes, a structured MEDLINE search using the subject headings warfarin, hemorrhage, coumarins, and clinical trials was also performed. The database was also searched for the corresponding keywords (Appendix 9). This strategy yielded 322 articles. The abstracts for these articles were reviewed and those, whose primary subject was meta-analysis of bleeding secondary to warfarin therapy, or intracranial hemorrhage, were retrieved for full review. This strategy yielded 22 articles. The full text of these articles was then reviewed. Articles were excluded if they were not meta-analyses, prospective cohort studies of patients on oral anticoagulants for DVT or did not address intracranial hemorrhage. This yielded six articles. Only one dealt solely with intracranial hemorrhage secondary to oral anticoagulant therapy (87). This study consisted of a case series of patients with warfarin related intracranial hemorrhage. Four articles were meta-analyses (86,88-90) and one study was a prospective cohort study (91). Rates for major bleeding were therefore abstracted from the two studies on duration of therapy in idiopathic DVT and the rates from the other five articles were used to determine the ranges for sensitivity analysis. Since there were no deaths or intracranial hemorrhages secondary to bleeding in the two randomized trials on duration of therapy in idiopathic DVT, these rates were obtained from a systematic review by Levine that was found by searching our own reference database (86).

In summary, estimates of rates of major bleeding while on oral anticoagulant therapy for idiopathic DVT were derived from the two randomized trials on duration of

therapy in idiopathic DVT (15,16). Ranges for sensitivity analysis were derived from four meta-analyses on bleeding secondary to oral anticoagulants in patients with atrial fibrillation and one prospective study of patients on oral anticoagulants for VTE (86,88-90,91).

### *5.1.3 Probability of pulmonary embolism and fatal pulmonary embolism after recurrent VTE*

The rates of pulmonary embolism with recurrent VTE were extracted from the trials on duration of therapy. Only one of the trials provided this data (15). However since it was not reported if the patients who presented with PE at the time of recurrent VTE were the ones who initially presented with PE at the time of their first episode of VTE, this rate was not used. This is because patients presenting with PE are more likely to die of recurrent PE than are patients presenting with DVT (35). The rate of PE given recurrent VTE and the rate of death from PE were therefore obtained from a meta-analysis of the risk of fatal PE in patients with recurrent VTE by Douketis et al (35). A literature search for further articles on systematic review of rates of fatal PE and non-fatal PE after recurrent VTE did not yield any additional references.

In summary, estimates of the risk of PE given recurrent VTE and death secondary to PE were derived from the LAFIT trial and a review by Douketis et al (15,35).

#### ***5.1.4 Probability of post-thrombotic syndrome***

Neither one of the two trials on duration of anticoagulation reported on rates of post-thrombotic syndrome. A MEDLINE search using the subject heading “post-thrombotic syndrome” was therefore performed. The database was also searched for the corresponding keywords. This strategy yielded 195 articles. One hundred and seventy five were excluded because the subject matter related to diagnosis of post-thrombotic syndrome, use of thrombolytic therapy or surgical treatment. Therefore, 20 articles were retrieved for full text review. Seventeen articles were then excluded because they were review articles, diagnostic studies, retrospective cohort studies, surgical studies, or studies on post-operative DVT. Three articles were therefore used for data abstraction (27,64,92). Only one of these articles gave rates of post-thrombotic syndrome after recurrent DVT (64).

In summary, estimates of the risk of developing post-thrombotic syndrome were derived from three prospective trials (27,64,92).

#### ***5.2 Data abstraction***

Rates extracted from the literature were converted into probabilities. A rate is the likelihood of transition to any other state at a given point in time. A probability is however the proportion of the population at risk that makes a transition to a given state over a specified time, which is usually one cycle length. Miller and Homan have therefore proposed a method for transforming rates (which are what are typically reported in the medical literature) into cycle-specific probabilities (93).

The following formula was used in order to convert the rates extracted from the literature into probabilities (63):

$$\text{Probability} = 1 - e^{-\text{rate} \cdot \text{time}}$$

where time = (duration of probability period)/(duration of rate period)

For example, the probability of developing severe post-thrombotic syndrome after recurrent DVT was calculated as follows:

“11% of patients developed severe post-thrombotic syndrome...most cases occurred within 24 months of the acute thrombotic event” (92);

$$\text{Therefore probability in a 3-month cycle} = 1 - e^{-\text{rate} \cdot \text{time}} = 1 - e^{(-0.11 \cdot 3/24)} = 1 - 0.9863 = 0.0137$$

This method, however, is only valid if the rate is constant over time. This therefore applies to outcomes such as bleeding but does not apply to the risk of developing post-thrombotic syndrome for example, where the majority of patients who develop this illness do so within 24 months of the initial DVT (27,64,92). In this instance, the cycle-specific probability was calculated and factored into the model until the individual in question had passed through 8 cycles (24 months). A “condition rule” was then applied such that the probability of developing this outcome was zero after this time.

Previous decision analyses in this area have used probabilities interchangeably with rates (36,39,42). This may result in errors of up to 14% in the determination of transition probabilities (93). The error lies in the definition of these concepts.

A “best estimate” of the probability of each outcome was determined by using the reference with the strongest methodology. Thus where available, rates from meta-

analyses were to calculate the “best estimate”. If no data from meta-analyses were available, rates from randomized trials were used preferentially over prospective cohorts. The range of values extracted from all sources was also recorded for use in sensitivity analysis. For the rates of recurrent VTE for patients on lifelong therapy, rates of recurrence were extrapolated from existing studies on shorter duration of therapy. In this instance, broad ranges of biologically plausible values were used in the sensitivity analysis.

## **6.0 Outcomes**

Probabilities of each of the possible outcomes are presented in Table 2. The “best estimate”, range and sources are also presented for each outcome.

### ***6.1 Probability of recurrent VTE***

Probabilities of recurrent VTE for each of the treatment durations were obtained when possible from the articles retrieved from the two studies on duration of therapy for first episode idiopathic DVT (15,16). Since the two randomized studies on duration of therapy only studied patients after the initial three months of therapy was complete, the rates of recurrent VTE during three months of therapy were obtained from the most recent meta-analysis comparing low molecular weight heparin to unfractionated heparin (94). In this study, the rate of recurrent VTE in patients receiving low molecular weight heparin (which is the current standard of care), was 5.4% over 6 months. This rate was converted into a cycle-specific probability of 0.0266 in order to estimate the rate of recurrent VTE on oral anticoagulant therapy during the first three months of treatment.

As the current minimum duration of therapy for first episode DVT is 3 months, rates of recurrent VTE in patients receiving less than 3 months of treatment were not considered.

The rate of recurrent VTE during 3 to 6 months of therapy was abstracted from the LAFIT and WODIT trials (15,16). The LAFIT study rate was used as the best-estimate because the WODIT data has not yet been subjected to peer review. The annual rate of 1.3% for recurrent VTE in patients on therapy was converted to a cycle-specific probability of 0.0032. The rate from WODIT (1.5% per year) was used in the sensitivity analysis. The rate of recurrent VTE between 3 and 6 months in patients who stopped therapy after 3 months was obtained from the LAFIT study. Abstracting from the event curve represented in Figure 1 of the study, the recurrence rate at 6 months, was 18%. This was converted to a cycle-specific probability of 0.0861. The WODIT data provided rates from 3-12 months of therapy; thus the rate of 7.5% was converted to a 3 month cycle-specific probability of 0.0247.

The rates of recurrent VTE on therapy appear to plateau after 6 months of therapy (15,16), thus the annual rates of 1.3% and 1.5% from the LAFIT and WODIT trials respectively were converted to cycle-specific probabilities. This produced a best-estimate of 0.0032 for the cycle-specific probability for rates of recurrent VTE on therapy for the remaining durations of therapy. The rates of recurrent VTE for patients who stop therapy after 6 months were abstracted from the LAFIT data by subtracting 18% (rate in the first 6 months) from the total rate of 27.4% over the first year. This produced a rate of 9.4% over a 6 month period, which was converted to a cycle-specific probability of 0.0459. The WODIT rate of 7.5% during 3-12 months of therapy was used in the sensitivity analysis.

For patients who discontinue therapy after 12 months, the only rates available were from interpolation of the WODIT data. Over a 2 year period, the group off therapy had a recurrence rate of 11.8%. The recurrence rate was 1.5% in the group on 1 year of therapy, thus the rate of recurrence after 12 months of therapy during the next year is  $11.8\% - 1.5\% = 10.3\%$ . This rate was converted to a cycle-specific rate of 0.0254.

For patients who discontinue therapy after 24 months, there are no rates available. This is being studied in the ongoing follow-up of the LAFIT cohort but this data is not yet complete. There has only been one randomized study on long term anticoagulation for VTE (61). This was a study published by Schulman et al on the duration of oral anticoagulant therapy after a second episode of VTE. In this study, patients were followed for four years. In the group assigned to discontinue therapy after six months, there was a 20.7% recurrence rate over the study period. This rate was converted into a cycle-specific probability of 0.0129. Since this data is from patients with a second episode of DVT, a wide range of values were used in the sensitivity analysis as the true rate for the population in question is unknown. Once available, the data from LAFIT will be used in the model.

### ***6.2 Probability of DVT or PE given recurrent VTE***

There was only one publication that provided rates of PE given recurrent VTE in patients who initially present with DVT (35). In this systematic review, 21.4% of patients presenting with DVT have PE as a manifestation of recurrent VTE. This study included patients with all causes of VTE; thus rates may not truly reflect rates of PE in patients with idiopathic DVT. The LAFIT study had a PE rate of 35% in patients with

recurrent VTE but some of these patients initially presented with PE, thus this rate is likely to be higher than one would expect in patients who first presented with DVT.

### ***6.3 Probability of major, fatal, and intracranial hemorrhage secondary to oral anticoagulant therapy***

The rate of major bleeding was obtained from the LAFIT study. Thus the rate of major bleeding was 3.8% per year. This was converted to a cycle-specific probability of 0.0095. The rate of 2.96% from the WODIT data was used in the sensitivity analysis, in addition to rates from a systematic review of patients on oral anticoagulant therapy for atrial fibrillation (90).

The risk of death from bleeding secondary to anticoagulants was not available from the LAFIT or WODIT trials because there were no deaths. The rate was obtained from a review by Levine, which pooled data from studies on patients on anticoagulants for VTE (86). In this review, the case-fatality ratio of major bleeding was 15%. This review was also used to obtain the rate of intracranial hemorrhage secondary to oral anticoagulants, resulting in a rate of 0.3% per year in patients with an INR of 2-3. Thus, the cycle-specific probability of intracranial hemorrhage was 0.0007.

### ***6.4 Probability of developing post-thrombotic syndrome***

The best estimate for probability of post-thrombotic syndrome was obtained from a randomized trial of compression stockings (92). The current practice is to prescribe stockings to all patients; thus rates of post-thrombotic syndrome were obtained from the stocking group. Rates of post-thrombotic syndrome in patients who are not prescribed

compression stockings were included in the sensitivity analysis. Severe post-thrombotic syndrome occurred in 11% of patients. This rate was therefore converted to a cycle-specific probability of 0.0137 (assuming that all patients who develop post-thrombotic syndrome do so in the first 24 months after presentation with DVT). Because most cases of post-thrombotic syndrome occurred within 24 months of the acute thrombotic event, a condition rule was applied to the model such that post-thrombotic syndrome did not occur after 24 months. Sensitivity analysis of the time to occurrence of post-thrombotic syndrome was performed in order to test how this assumption affected the outcome. A rate of 9.3% was used for the sensitivity analysis, based on the study by Prandoni et al (64).

Only one study provided clear rates of post-thrombotic syndrome after recurrent VTE (64). In this study, 46% of patients developed moderate-to-severe post-thrombotic syndrome after recurrent VTE. This was therefore converted into a cycle-specific rate of 0.0559. A range of 25%-67% based on this study was used for the sensitivity analysis.

### ***6.5 Probability of death secondary to PE after recurrent VTE***

Since it was impossible to discern if the fatal PE occurred in a patient presenting initially with PE in the LAFIT study (only one fatal PE occurred in this study), the probability of death secondary to PE after recurrent VTE was not extracted from this study. This rate was therefore obtained from the study by Douketis, in which the case-fatality rate for PE was 5.6% (35).

### ***6.6 Probability of recurrent VTE while on lifelong OAC after a second episode of VTE***

There is only one randomized trial on the duration of anticoagulant therapy after a second episode of VTE (61). In this study, patients who had a second episode of VTE were given six months of OAC therapy or indefinite therapy. The rates of VTE in the latter group were therefore extracted to determine the probability of recurrent VTE in patients placed on lifelong OAC after a second episode of VTE. The results of this study suggested that long-term secondary prophylaxis is effective in patients with recurrent VTE and is the basis for the current practice of placing patients who have recurrent VTE on lifelong therapy. Thus in the decision model, all patients who have recurrent VTE regardless of the duration of therapy for the first episode are placed on long-term OAC.

This study by Schulman randomized 116 patients with a second episode of VTE to long term therapy. After four years of follow-up, there was a 2.6% rate of recurrence in this group. The annual probability for recurrent VTE after a first episode DVT in patients placed on long-term therapy was therefore 0.0065.

**Table 2: Rates and probabilities of outcomes**

<b>OUTCOME</b>	<b>RATE (RANGE)</b>	<b>CYCLE-SPECIFIC BASE-CASE ESTIMATE (RANGE)</b>	<b>LEVEL OF EVIDENCE *</b>	<b>SOURCE (REFERENCE)</b>
<i>Recurrent VTE during first 3 months of OAC</i>	5.4% over 6 months (0-13%)	0.0266 (0-0.0629)	I	(94)

<i>Recurrent VTE between 3-6 months <u>on</u> OAC</i>	1.3% per year (0-28%)	0.0032 (0-0.0676)	II	(15,16)
<i>Recurrent VTE between 3-6 months <u>off</u> OAC</i>	18% over 6 months <sup>#</sup> (0-28%)	0.0861 (0-0.1306)	II	(15,16)
<i>Recurrent VTE between 6-12 months <u>on</u> OAC</i>	1.3% per year (0-28%)	0.0032 (0-0.0676)	II	(15,16)
<i>Recurrent VTE between 6-12 months <u>off</u> OAC<sup>¶</sup></i>	9.4% over 6 months <sup>#</sup> (0-28%)	0.0459 (0-0.1306)	II	(15,16)
<i>Recurrent VTE between 12-24 months <u>on</u> OAC</i>	1.3% per year (0-28%)	0.0032 (0-0.0676)	II	(15,16)
<i>Recurrent VTE between 12-24 months <u>off</u> OAC<sup>¶</sup></i>	10.3% per year <sup>9</sup> (0-28%)	0.0254 (0-0.0676)	II	(16)
<i>Recurrent VTE between 24 months-lifelong <u>on</u> OAC</i>	1.3% per year (0-28%)	0.0032 (0-0.0676)	II	(15,16)
<i>Recurrent VTE between 24 months-lifelong <u>off</u> OAC<sup>¶</sup></i>	20.7% over 4 years (0-28% per year)	0.0129 (0-0.0676)	II	(15,61)
<i>Recurrent VTE after a second episode of VTE on OAC<sup>v</sup></i>	2.6% over 4 years (0-28% per year)	0.0016 (0-0.0676)	II	(15,61)
<i>Probability of PE with recurrent VTE</i>	21% (10-35%)	0.21 (0.10-0.35)	I	(15,35)
<i>Probability of death from PE</i>	5.6% (0-16%)	0.056	I	(15,35)

<i>Moderate to Severe post-thrombotic syndrome</i>	11% over 2 years (6.9-47 %)	0.0137 (0.0086-.0571)	II	(27,64,92)
<i>Moderate to Severe post-thrombotic syndrome with recurrent DVT</i>	46% over 2 years (6.9-100% over 2 years)	0.0559 (0.0086-0.1175)	III	(64)
<i>Intracranial hemorrhage</i>	0.3% per year (0-0.89% per year)	0.0007 (0-0.0022)	I	(17,73,86,91)
<i>Fatal hemorrhage</i>	15% of major bleeds (0-0.6% per year)	0.0014 (0-0.0014)	I	(86,88-91)
<i>Major hemorrhage</i>	3.8% per year (0-3.8% per year)	0.0095 (0-0.0095)	II	(15,16,86,90)

\*Levels of evidence: I (meta-analysis); II (randomized clinical trial); III (prospective cohort)

¶ Patients discontinue OAC therapy at the beginning of this time period

∇ Patients with recurrent VTE are on lifelong OAC

# Interpolation from Figure 1 by Kearon et al (15)

∑ Interpolation from rates by Agnelli et al (16)

## 7.0 Assumptions

Several assumptions were necessary in order to complete the model. For the outcome of bleeding, we assumed that the rate of bleeding secondary to anticoagulants was highest during the initial three month period of treatment and was constant over time thereafter (91). It was also assumed that major bleeding could only lead to death, permanent neurologic sequelae secondary to intracranial hemorrhage, or a two week period off anticoagulants with subsequent resumption of anticoagulant therapy over the

following two weeks. The possibility of recurrent VTE while off anticoagulant therapy for these two weeks was considered to be too small to factor into the model. Minor bleeding was not considered because often there is no interruption of anticoagulation.

All patients with an intracranial hemorrhage secondary to OAC were assumed to have survived this event but were left with permanent neurologic sequelae. This is a conservative approach as one study reported a 77% mortality rate with this complication (87). In this same study, none of the survivors was free from neurologic deficits.

For the outcome of post-thrombotic syndrome, only moderate-to-severe disease was considered in order to simplify the model. This was because it was initially assumed that the utility for mild post-thrombotic syndrome would be very high (43). The risk of developing post-thrombotic syndrome after having sustained permanent neurologic sequelae secondary to hemorrhage was not considered in order to make the model tractable. Furthermore, the utility for this state was expected to be so low that the additive effect of post-thrombotic syndrome was unlikely to be of major impact. It was assumed that all patients were prescribed graduated compression stockings (30-40 mm Hg), thus rates for post-thrombotic syndrome were derived from patients who wore these garments (92). It was also assumed that death would occur if an individual sustained recurrent VTE while in the state of permanent neurologic sequelae.

The utility of being off anticoagulants was assumed to be 1 (as there was no longer the burden of bloodtests, drug interaction and risk of bleeding) and the utility for being on anticoagulants after recurrent VTE was the same as being on anticoagulants for the first time.

## **8.0 Uncertainty Analysis**

Before the results of the analysis could be interpreted, extensive sensitivity analysis is required to assess the robustness of the results. This is the process by which the tree is repeatedly folded back using different values for all possible variables. There are two main reasons for performing this analysis. The first is to assess for possible errors within the decision tree. The second is to assess the degree of uncertainty associated with the results.

### ***8.1 Assessment for errors in the model***

The term “bug” is used to describe a structural or programming error that affects the results of the tree (11). The process of “debugging” was achieved by changing one variable at a time over its entire range. The results were then evaluated graphically and examined to see if they made sense (i.e. whether they correspond to predictions of what should happen as variables change). If a slope or intercept does not appear to make biologic sense (for example increasing the probability of dying from PE does not decrease life expectancy), then there is likely an error in the model. The bug is found and repaired by reconstructing the tree and examining each variable as it arises. All expressions are also reviewed to ensure they are correct. Sensitivity analysis was therefore performed for each of the variables. For the probabilities of events, the range used was from 0-0.99. A range of 0-1 was used for the utilities. Age was varied across the range of 18-100 years.

A Markov analysis of the probability of events for each of the treatment durations was also performed to ensure the members of the cohorts progressed logically over time. This analysis shows how the cohort is distributed at each cycle (63).

### ***8.2 Assessment of robustness of results***

In any decision model there is uncertainty in the specification of probabilities and utilities. Therefore, one must investigate the impact of this uncertainty upon determination of which strategy is “best choice”. A method of exploring this uncertainty is sensitivity analysis. This method involves varying a given utility or probability over its entire biologically plausible range or over the range of values abstracted from the literature while the remaining variables are kept at their “best estimate”. To do so, sensitivity analysis was used as follows:

One-way sensitivity analysis was performed for each variable where only the variable in question was varied over its range while all other variables remained constant. The results were plotted graphically, with the values of the variable on the X-axis and on the Y-axis, the discounted quality adjusted life expectancy. The points where the lines crossed, known as “thresholds”, were those where the preferred alternative changes. Thus, a value above this level would be more attractive to the patient while a value below this level would be less attractive to the patient.

Two and three-way sensitivity analyses were also performed. In this manner several variables would be varied over their range of possible values simultaneously.

Sensitivity analyses were performed over the ranges of values for each variable in the decision model. For those values with no ranges, arbitrary ranges with biologic plausibility were chosen.

For example, one-way analyses using changes in the values patients assign to post-thrombotic syndrome were examined in order to examine the benefit achieved with longer-term anticoagulant therapy. Two-way analyses and three-way analyses varying the variables that the model was sensitive to were also examined. Multi-way sensitivity analyses also permitted the consideration of the inconvenience of anticoagulation in the context of all of the possible outcomes.

Monte Carlo simulation is an alternative method of uncertainty analysis that uses repeated random sampling of the value of each variable in the model to generate a measure of central tendency and variability in the outcome (96). Since the differences between strategies were small and the uncertainty in values large, Monte Carlo simulation was not used. Even without use of Monte Carlo simulation it was already apparent that confidence intervals for the strategies would overlap.

### **8.3 Best and worst case scenarios**

The model was also analyzed under best and worst-case scenarios. This was done by analyzing the model by first setting all the variables at of their extremes of their plausible ranges to favour one strategy (bias in favour of longer duration anticoagulation) and then setting all the variables at the opposite extremes to bias in favour of shorter duration anticoagulation.

## **RESULTS**

### **1 Utilities**

#### ***1.1 Respondents***

Fifty patients and 30 volunteers were interviewed. The mean (+/-SD) age of the patients was 60 (9.44) and the mean age for the volunteers was 48 (14.4). Fifty eight percent of respondents were female. Three interviews (one volunteer and two patients) were excluded because respondents were unable to assign a lower utility to “blind in both eyes” when compared to “blind in one eye”.

#### ***1.2 Utility values***

The mean (+/-SD) utilities for the states of being on oral anticoagulants, mild post-thrombotic syndrome, moderate-to-severe post-thrombotic syndrome, and permanent neurologic sequelae secondary to intracranial hemorrhage were 0.928 (0.086), 0.898 (0.113), 0.809 (0.175), and 0.356 (0.309) respectively. The mean and median values for each of health states are presented in Table 3.

**Table 3: Utility estimates**

<b>Health state</b>	<b>Mean</b>	<b>Median</b>	<b>Minimum</b>	<b>Maximum</b>	<b>SD</b>
<b>On oral anticoagulants</b>	0.928	0.980	0.540	1	0.089
<b>Mild post-thrombotic syndrome</b>	0.898	0.940	0.500	1	0.113

<b>Moderate-to-severe post-thrombotic syndrome</b>	0.809	0.840	0.260	1	0.175
<b>Permanent neurologic sequelae secondary to intracranial hemorrhage</b>	0.356	0.350	0	0.990	0.309

Table 3: Mean, median and ranges of utility estimates for each of the outcomes of interest.

All patients were able to appropriately order the states from best to worst. Some respondents gave the same value to being on oral anticoagulants and mild post-thrombotic syndrome. However, the outcome of mild post-thrombotic syndrome was not considered in the model.

### ***1.3 Tests of hypotheses***

T tests for equality of means for independent samples were used to test the hypothesis that there was no difference between the utility value for a given health state for healthy volunteers and patients. A p value of  $<0.05$  allowed us to reject the null hypothesis. All p values were  $>0.05$ , thus the null hypothesis could not be rejected and the mean utilities for each of the conditions were equal for patients and healthy volunteers. Using the assumption of equal variances and 2-tailed tests, there were no differences between mean utility estimates for patients and healthy volunteers for any of the conditions (Table 4).

**Table 4: T-test for independent samples**

<b>Condition</b>	<b>Mean utility</b>	<b>Standard deviation</b>	<b>t</b>	<b>df</b>	<b>p value</b>
On oral anticoagulants	0.928	0.089	1.252	75	0.214
Mild post-thrombotic syndrome	0.898	0.113	1.076	75	0.285
Moderate-to-severe post-thrombotic syndrome	0.809	0.175	1.232	75	0.222
Permanent neurologic sequelae secondary to intracranial hemorrhage	0.356	0.309	0.481	75	0.632

Table 4: T-test for independent samples to test the hypothesis of equal means between patients and healthy volunteers.

Histogram plots of the utilities for some of the scenarios were not symmetrical. Therefore, the non-parametric Mann-Whitney test was used to confirm that the median utilities were the same for patients and volunteers (74). For each of the scenarios, the p value for the Mann-Whitney test exceeded 0.05, thus the null hypothesis of equal utilities for each clinical condition could not be rejected (Table 5).

**Table 5: Mann-Whitney test**

<b>Condition</b>	<b>MW statistic</b>	<b>p value</b>
On oral anticoagulants	584.50	0.223
Mild post-thrombotic syndrome	574.00	0.190
Moderate-to-severe post-thrombotic syndrome	529.00	0.079
Permanent neurologic sequelae secondary to intracranial hemorrhage	612.00	0.376

Table 5: Mann-Whitney test for comparison of utilities for patients and healthy volunteers.

In order to test the hypothesis of no difference in mean utilities for the different health states, repeated measures analysis of variance was used. A statistically significant difference was obtained (p value <0.05). Therefore, the null hypothesis that the mean utility for being on oral anticoagulants was the same as the mean utility for mild post-thrombotic syndrome, severe post-thrombotic syndrome, and permanent neurologic sequelae secondary to intracranial hemorrhage was rejected (Table 6).

**Table 6: Repeated-measures analysis of variance**

<i>Source</i>	<i>Degrees of freedom</i>	<i>Sum of squares</i>	<i>Mean square</i>	<i>F</i>	<i>Sig. of F</i>
Between subjects	n-1 = 76	SSBS = 5.61	0.07	2335.58	<0.0001
Within subjects	k-1 = 3	SSWS = 16.34	5.45	223.01	<0.0001

Table 6: Repeated-measures analysis of variance tests the null hypothesis that there is at least one mean utility that does not equal another mean utility.

The results of the analysis of variance demonstrate that at least one mean utility does not equal another mean utility. The null hypothesis of equal mean utilities was therefore rejected. The non-parametric Friedman test was also used to test the hypothesis of identical population means (74). Using a p value of 0.05, the Friedman F statistic allowed us to reject the null hypothesis as well (Table 7).

**Table 7: Friedman test**

<b>Scenario</b>	<b>Mean rank</b>
X (oral anticoagulant therapy)	3.65
Y (mild post-thrombotic syndrome)	3.18
Z (moderate to severe post-thrombotic syndrome)	2.16
Q (permanent neurologic sequelae due to intracranial hemorrhage)	1.02
N	77
Chi-Square	208.918

df	3
p value	0.000

**Table 7: Friedman test of hypothesis that all possible rankings of means are equally likely.**

## **2 Structural integrity of model**

One-way sensitivity analysis was performed on all variables. For each analysis that did not make biologic sense, the entire model was reviewed until all analyses made sense. Markov analyses of probabilities of entering into the Markov states were also performed to ensure the logical progression of events (Figure 3). For example, the model made sense if the probability of death increased with time or the probability of being off anticoagulant therapy was very low for patients on lifelong therapy.

**Figure 3:**

Figure 3: Markov probability analysis for lifelong anticoagulant therapy. The figure depicts how the cumulative probability of death increases with time and how the probability of being off anticoagulants is very low (parallel to the X-axis).

### 3 Base case analysis

The life expectancies for patients on three, six, twelve, twenty-four months and lifelong therapy are 11.581, 11.573, 11.558, 11.533, and 11.429 life-years respectively. Thus, the gains in life expectancy for patients receiving three months of therapy are 0.095, 0.271, 0.574, and 1.83 months respectively when compared to the other durations of therapy (Table 8). Based on the best estimate of the value for each variable in the model, the optimum duration of therapy is three months. Three months of therapy is the

optimum duration of therapy for the other two payoffs: quality adjusted and discounted quality adjusted life expectancy respectively.

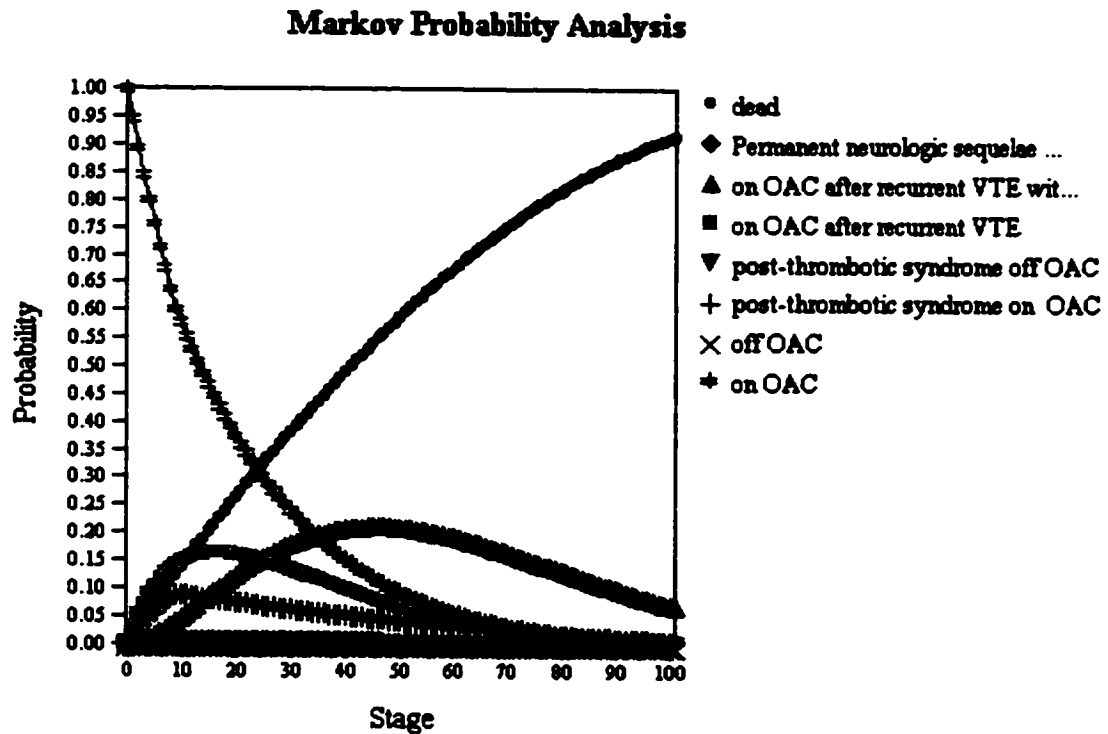
**Table 8: Base case results**

<b><i>Payoff</i></b>	<b><i>3 months OAC therapy</i></b>	<b><i>6 months OAC therapy</i></b>	<b><i>12 months OAC therapy</i></b>	<b><i>24 months OAC therapy</i></b>	<b><i>Lifelong OAC therapy</i></b>
<b>LE (years)</b>	11.581	11.573	11.558	11.533	11.429
<b>QALE (years)</b>	9.653	9.650	9.647	9.642	9.614
<b>Disc QALE (years)</b>	7.768	7.765	7.758	7.749	7.705
<b>LE gain using 3 months OAC therapy (months)</b>	-	0.095	0.271	0.574	1.83

Table 8: Life expectancy (LE), quality-adjusted life expectancy (QALE) and discounted quality-adjusted life expectancy (disc QALE) for each of the treatment strategies.

#### **4 Sensitivity analyses**

##### **4.1 One-way analyses**

One-way sensitivity analyses were performed on the value of each variable in the model (Table 9). The model favored the three-month strategy in all cases except for high rates of major bleeding and post-thrombotic syndrome, and for lower utilities for being on oral anticoagulants and for moderate-to-severe post-thrombotic syndrome. The model was also sensitive to the probability of recurrent VTE after a second episode of VTE while on lifelong therapy (but only at estimates similar to rates observed in patients off

therapy), as well as the utility for being off anticoagulant therapy (assuming patients felt a burden by being off therapy).

#### *4.1.1 Probability of major bleeding*

When the probability of major bleeding is less than 0.006 per cycle, lifelong therapy is favoured. Thus, if the annual rate of major bleeding is less than 2.4%, lifelong therapy becomes the preferred strategy (Figure 4).

#### *4.1.2 Probability of moderate-to-severe post-thrombotic syndrome*

When the probability of moderate-to-severe post-thrombotic syndrome exceeds 0.106 per cycle, longer-term therapy is preferred. This corresponds to an annual rate of 42%. Although this is within the range found in published data, at best it is similar to the rates in patients who are not prescribed graduated compression stockings (92). As patients who are followed in thrombosis units currently are routinely prescribed these devices, annual rates this high are unlikely to occur.

**Figure 4: One-way sensitivity analysis on the probability of major bleeding**

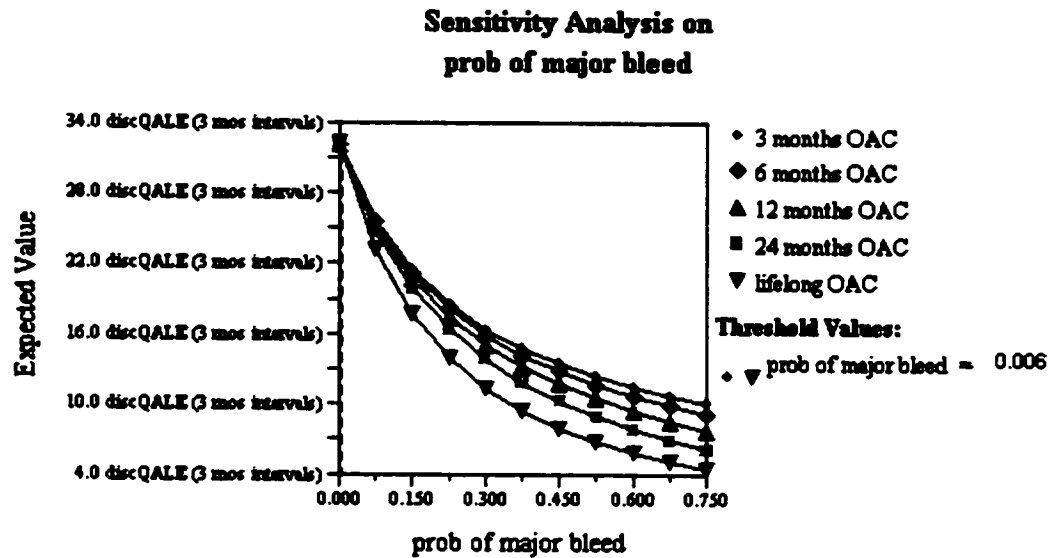

Figure 4: One-way sensitivity analysis of the effect of varying the probability of major bleeding secondary to oral anticoagulant therapy.

#### 4.1.3 Utility for being on oral anticoagulant therapy

When the utility for being on oral anticoagulant therapy is 1, lifelong therapy is preferred. Thus, if the patient does not perceive any burden attributable to anticoagulant therapy, lifelong therapy is preferred. However, if a patient burden is associated with this therapy, shorter duration therapy is favoured (Figure 5).

**Figure 5: One-way sensitivity analysis on the utility of oral anticoagulant therapy**

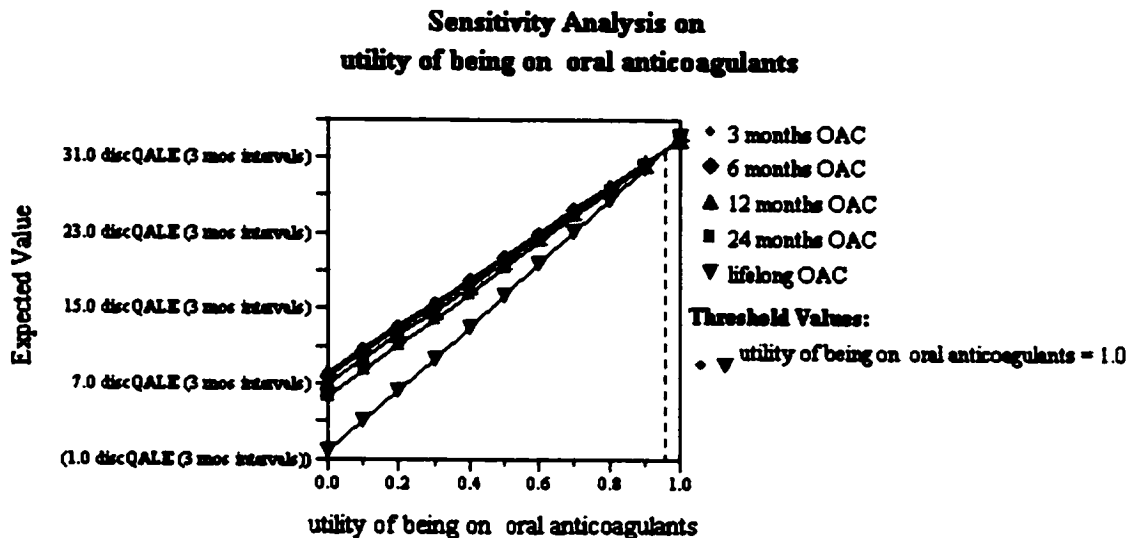

Figure 5: One-way sensitivity analysis of the effect of varying the utility for being on oral anticoagulant therapy. If the utility is less than 1.0, then shorter durations of therapy are preferred.

*4.1.4 Utility for moderate-to-severe post-thrombotic syndrome*

When the utility for moderate-to-severe post-thrombotic syndrome is less than 0.8, lifelong therapy is preferred (Figure 6).

**Figure 6: One-way sensitivity analysis on the utility of moderate-to-severe post-thrombotic syndrome**

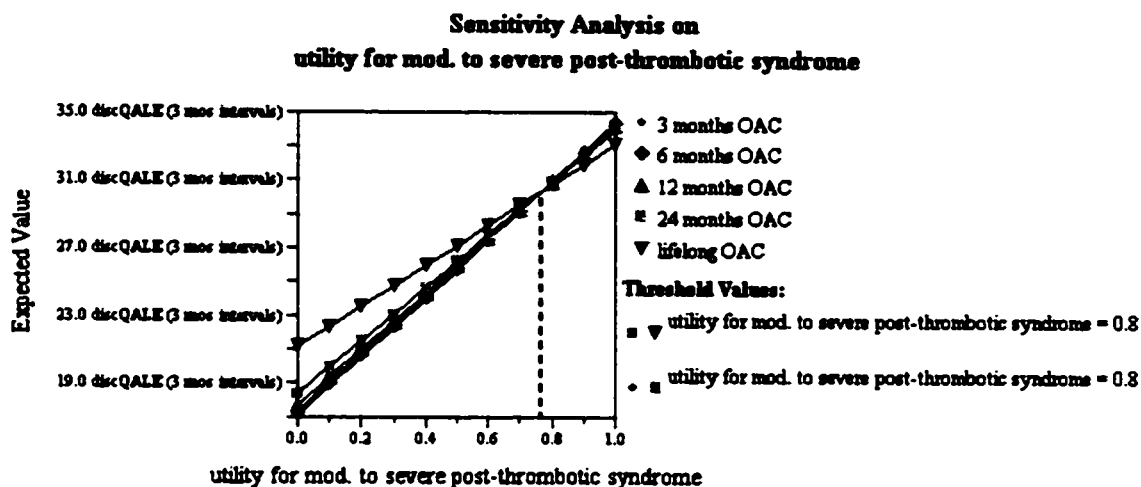

Figure 6: One-way sensitivity analysis of the effect of varying the utility for moderate-to-severe post-thrombotic syndrome. If the utility is less than 0.8, longer durations of therapy are preferred.

#### *4.1.5 Probability of recurrent VTE after a second episode of VTE on lifelong anticoagulant therapy*

When the cycle specific probability of recurrent VTE after a second episode of VTE while the patient is receiving lifelong therapy is greater than 0.021, lifelong therapy is preferred. This is unlikely to occur as this corresponds to a rate of approximately 8.4% per year. Such a rate exceeds the rate seen in patients who have had a second episode of VTE who are not taking anticoagulants (61).

#### *4.1.6 Utility for being off anticoagulant therapy*

If one assumes that patients may perceive a negative effect from not being on anticoagulant therapy, which seems counterintuitive, longer-term therapy is favoured if patients assign a utility of less than 1 to this health state. This seems unlikely, as most

patients would prefer not to be on a medication that has side effects and which imposes some restrictions on lifestyle.

**Table 9: Summary of one-way sensitivity analyses**

<b>Variable</b>	<b>Baseline Value (prob. per 3 months cycle)</b>	<b>Plausible range</b>	<b>Threshold value* (optimum duration of therapy)</b>	<b>Sensitive?#</b>
Prob. fatal bleed secondary to oral anticoagulants	0.0014	0.00-0.0014	0.003	No
Prob. intracranial hemorrhage secondary to oral anticoagulants	0.0007	0.00-0.0022	none	No
Prob. major bleed secondary to oral anticoagulants	0.0095	0.00-0.0095	0.006 (lifelong therapy favoured if prob. major bleed <0.006 per cycle)	Yes
Prob. death due to PE given recurrent VTE	0.056	-	0.155	No
Prob. PE given recurrent VTE	0.21	0.10-0.35	0.6	No
Prob. of post-thrombotic syndrome	0.0137	0.0086-0.0571	None	No

<b>Prob. of post-thrombotic syndrome given recurrent VTE</b>	<b>0.0559</b>	<b>0.0086-0.1175</b>	<b>0.106 (24 months favoured if prob. &gt;0.106 per cycle) 0.116 (lifelong therapy favoured if prob. &gt;0.116 per cycle)</b>	<b>Yes</b>
<b>Prob. of recurrent VTE after a second episode of VTE on lifelong anticoagulant therapy</b>	<b>0.0016</b>	<b>0.00-0.0676</b>	<b>0.021 (lifelong therapy favoured if prob. &gt; 0.021 per cycle)</b>	<b>Yes</b>
<b>Utility of permanent neurologic sequelae secondary to intracranial hemorrhage</b>	<b>0.356</b>	<b>0-0.990</b>	<b>None</b>	<b>No</b>
<b>Utility for oral anticoagulant therapy</b>	<b>0.928</b>	<b>0-1</b>	<b>1(lifelong therapy favoured if utility =1)</b>	<b>Yes</b>
<b>Utility for being off anticoagulant therapy</b>	<b>1</b>	<b>NA</b>	<b>1(lifelong therapy favoured if utility is &lt;1)</b>	<b>Yes</b>
<b>Utility for moderate-to severe post-thrombotic syndrome</b>	<b>0.809</b>	<b>0.260-1</b>	<b>0.8 (3 months therapy favoured if utility &gt; 0.8)</b>	<b>Yes</b>

\*The threshold value is the value of the variable at which two strategies are equivalently valued (equal disc QALE).

#Sensitive means that a strategy other than 3 months is preferred for some value of the variable within the plausible range. Y=yes, the analysis is sensitive to this variable; N=no, the analysis is not sensitive.

#### 4.2 Two-way sensitivity analysis

The probabilities of recurrent VTE on and off anticoagulant therapy were assessed using two-way sensitivity analysis. One-way analysis of these variables was not performed because the model was designed such that the probabilities of recurrent VTE both on and off anticoagulant therapy were linked to the duration of therapy rather than linked to each other. This analysis demonstrated that for increasing probabilities of recurrent VTE off therapy, longer duration therapy is preferred. However, the model preferred three months of therapy over wide ranges of probabilities both off and on anticoagulant therapy (Figure 7).

**Figure 7:**

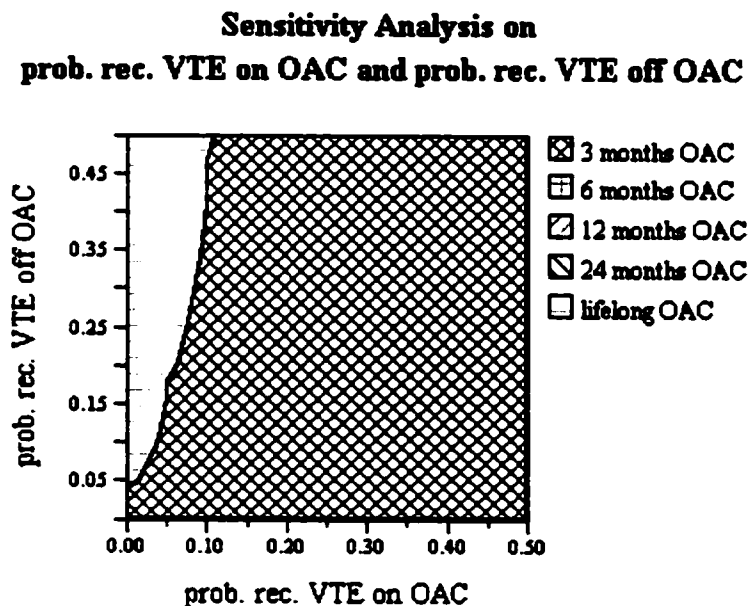

**Figure 7: Two-way sensitivity analysis of the probabilities of recurrent VTE on and off anticoagulant therapy.**

### ***4.3 Multi-way sensitivity analyses***

One-way sensitivity analysis revealed that there were four variables that had an effect on the optimal strategy: the probability of major bleeding, the utility for anticoagulant therapy, the probability of recurrent VTE on oral anticoagulant therapy, and the utility for moderate-to-severe post-thrombotic syndrome. The other variables that affected the relative desirability of the treatment strategies only did so out of the range of what is likely to occur given current practice and event rates.

Therefore, the probabilities of major bleeding, recurrent VTE on oral anticoagulant therapy and the utility for oral anticoagulant therapy were varied simultaneously (Figure 8). This graph illustrates the probability of major bleed on the horizontal axis and the probability of recurrent VTE on anticoagulant therapy on the vertical axis. The area in the bottom left corner of the graph represents the combination of values for these variables at which lifelong anticoagulation is preferred (i.e. associated with greater QALE). The rest of the graph illustrates the combination of values at which three months of therapy is preferred. The results of this analysis indicate that when the probabilities of recurrent VTE on oral anticoagulant therapy and major bleeding are less than approximately 12% and 16% per year respectively and the utility for being on oral anticoagulant therapy is greater than 0.925, lifelong therapy is preferred.

The probability of major bleeding, and the utilities for oral anticoagulant therapy and moderate-to-severe post-thrombotic syndrome were also examined in a three-way sensitivity analysis. This analysis demonstrated that as the utility for post-thrombotic syndrome decreases, longer-term anticoagulation is preferred over a wide range of

probabilities of major bleeding and biologically plausible ranges of utility for oral anticoagulant therapy (Figure 9).

**Figure 8: A: Utility for OAC = 1**

**Sensitivity Analysis on  
prob. of major bleed and prob. rec. VTE on OAC and utility of being on oral anticoagulants**

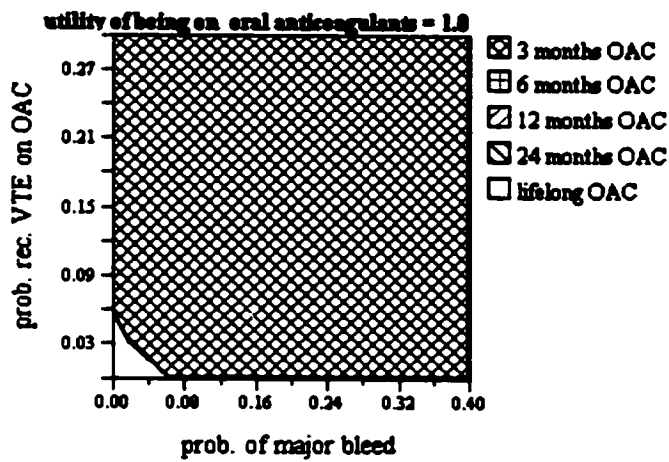

B:

**Sensitivity Analysis on  
prob. of major bleed and prob. rec. VTE on OAC and utility of being on oral anticoagulants**

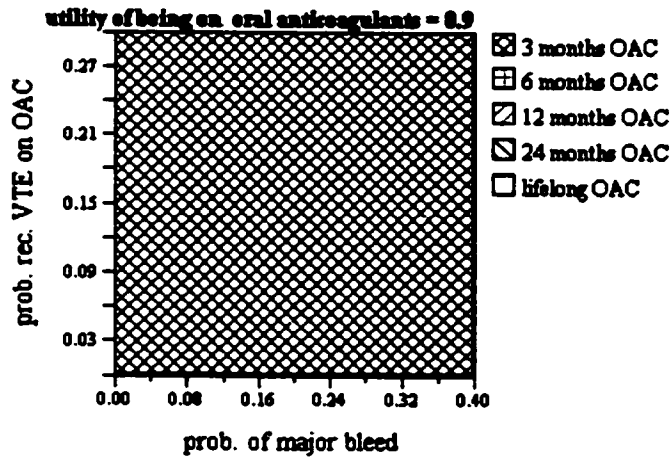

C:

**Sensitivity Analysis on  
prob. of major bleed and prob. rec. VTE on OAC and utility of being on oral anticoagulants**

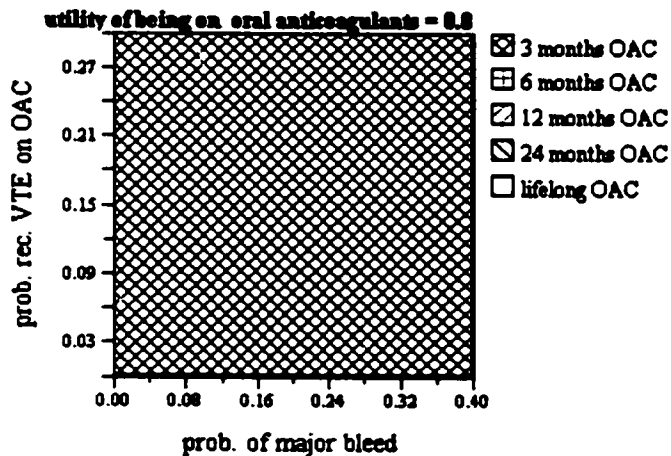

**Fig. 8: Three-way sensitivity analysis of the effect of varying the probabilities of major bleeding, recurrent VTE on anticoagulant therapy, and the utility of oral anticoagulant therapy on the optimum strategy. When the utility for being on oral anticoagulant therapy is less than 0.8, three months of therapy is preferred over a wide range of probabilities of bleeding and probability of recurrent VTE on oral anticoagulants.**

**Figure 9:****A:**

**Sensitivity Analysis on  
utility for OAC and prob. of major bleed and utility for PTS**

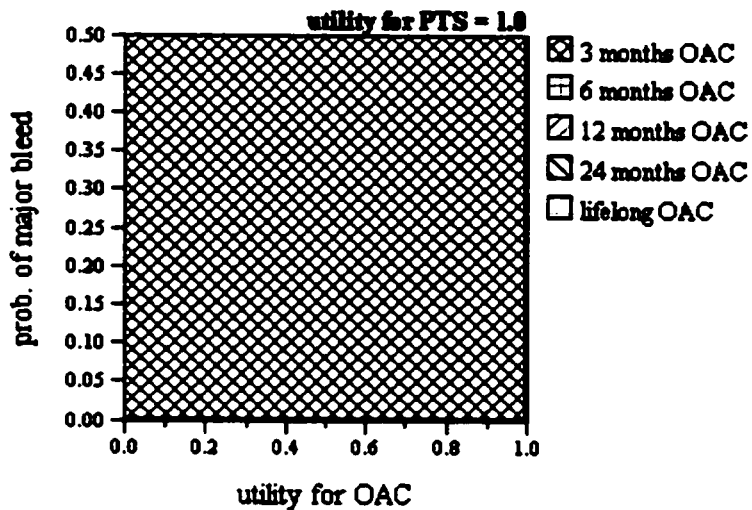
**B:**

**Sensitivity Analysis on  
utility for OAC and prob. of major bleed and utility for PTS**

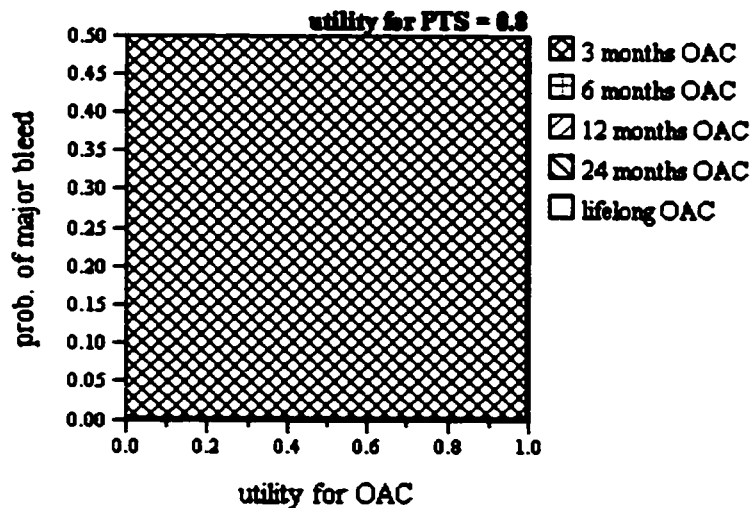

C:

**Sensitivity Analysis on  
utility for OAC and prob. of major bleed and utility for PTS**

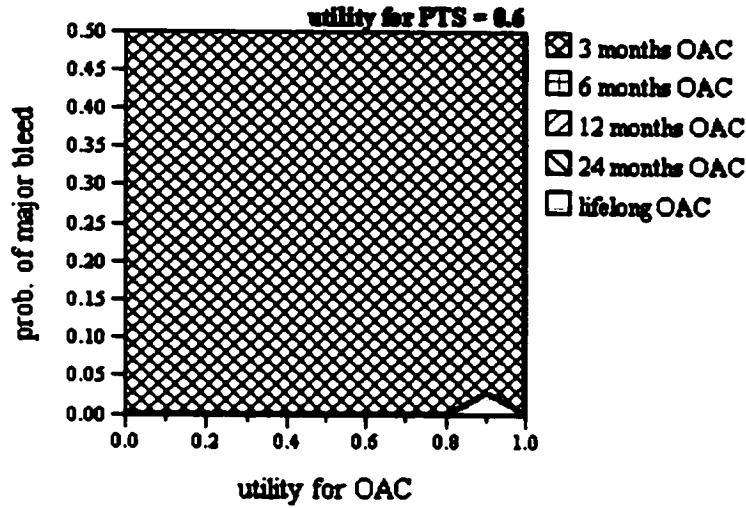

D:

**Sensitivity Analysis on  
utility for OAC and prob. of major bleed and utility for PTS**

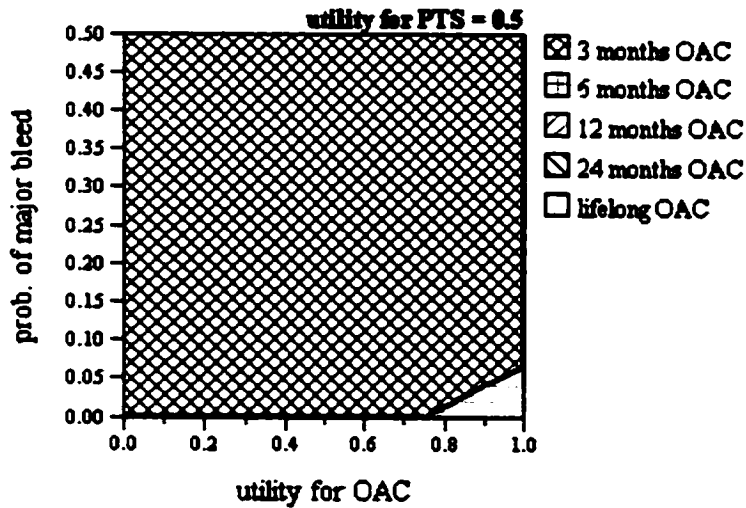

Fig. 9: Three-way sensitivity analysis of the effect of varying the probability of major bleeding, and the utilities for oral anticoagulant therapy and moderate-to-severe post-thrombotic syndrome. Longer-term anticoagulation is preferred as the utility for post-

thrombotic syndrome decreases even over a wide range of probabilities of major bleeding.

#### ***4.4 Best case and worst case scenarios***

Best and worst case scenarios were performed using the extreme values for the variables that were shown to affect the choice of optimal treatment strategy (Table 10). Thus, the analysis was performed to “bias” in favour of longer-term therapy by using the lowest possible value for major bleeding and the highest utility for being on oral anticoagulant therapy. Using this scenario, the rate of major bleeding would be zero and the utility for being on oral anticoagulant therapy would be one (patients do not perceive any burden from being on oral anticoagulant therapy). With this scenario which would bias in favour of longer-term therapy, lifelong therapy becomes the favoured treatment duration with a discounted QALE of 8.704 years. This represents a gain of 11.23 months when compared to the base-case estimate.

When the analysis was performed to “bias” in favour of shorter duration therapy by using the highest rates of major bleeding and the lowest utility for oral anticoagulant therapy, three months of therapy remains the optimum strategy with a discounted QALE of 6.677 years. This represents a loss of 13.10 months when compared to the base-case estimate.

**Table 10: Bias in favour of longer-term anticoagulation and shorter-term anticoagulation: comparison to base-case analysis**

<b>Variable</b>	<b>Bias in favour of longer duration anticoagulation</b>	<b>Bias in favour of shorter duration anticoagulation</b>
Annual probability of major bleeding	0	3.8%
Utility for anticoagulant therapy	1	0.7508 (mean – 2 SD)
Gain in life expectancy (months)	Favours 3 months of therapy (gain of 5.22 months)	No gain or loss
Gain in discounted QALE (months)	Favours lifelong therapy (gain of 11.22 months)	Favours 3 months of therapy (but loss of 13.10 months)

Table 10: Best and worst-case scenarios using highest rates of bleeding and lowest utility for oral anticoagulant therapy to bias in favour of shorter duration of therapy and then using lowest rates of bleeding and highest utility for oral anticoagulant therapy to bias in favour of longer duration of therapy.

## **DISCUSSION**

Historically, the best duration of oral anticoagulant therapy for first episode DVT has been unclear. Conflicting studies and consensus reports have recommended durations of therapy that range from six months to at least 2 years. The ongoing follow-up of the LAFIT cohort may help address whether even more than 24 months of secondary prophylaxis is appropriate but these results, whatever they may be, will nonetheless conflict with other previously published studies. The follow-up of the LAFIT cohort will also not be able to address the possibility of lifelong anticoagulant therapy given the impracticalities of such a long follow-up. Decision analysis is one approach to answering this question. This methodology offers the additional benefit of allowing for assessment of patient preferences and assessment of multiple outcomes that may not be feasible under the confines of a clinical trial. Several previous decision analyses in this area have been published. However, they have been flawed in their methodology, have not addressed patients with idiopathic DVT alone, or have not considered all outcomes of interest. Furthermore, none of these analyses has examined the possibility of lifelong therapy. This analysis attempted to answer these questions by comparing all realistic treatment durations and examining all clinically relevant outcomes.

The results of the present analysis demonstrated that three months of therapy is associated with the highest quality-adjusted life expectancy. However, when one interprets the results of a decision analysis, one must always do so in the context of the degree of uncertainty. At one extreme, an analysis may be insensitive to all one-way and multi-way analyses. Such an analysis would be considered to be very robust and the

preferred strategy would be obvious. The other extreme is an analysis that is sensitive to small changes in one or several variables within a clinically plausible range. Such an analysis would have a high degree of uncertainty attached to its results. The latter situation was the case with this analysis as the preferred strategy was sensitive to small changes in the utility for oral anticoagulant therapy. Furthermore the absolute difference between the three month strategy and the other strategies was small. By choosing three months of therapy, there was a gain in life expectancy of 0.095, 0.271, 0.574, and 1.83 months when compared to 6, 12, 24 months and lifelong therapy respectively. Some authors have suggested that a life-expectancy gain of three months is significant, since it corresponds to risk reductions observed in clinical trials judged to have clinically significant outcomes (97). Gains of a few days or weeks are usually considered to be “toss-ups” (98-100). According to these criteria for a clinically significant gain, there is no clear difference between strategies.

The extensive literature review completed during the course of this project has highlighted some questions that still need to be answered. The first relates to a question posed by the analysis itself. In spite of the apparent conflicting evidence for the recommended duration of therapy for first episode idiopathic DVT, there has been only one published, randomized controlled clinical trial on the duration of therapy in idiopathic DVT (15). Thus one central issue to this question is the lack of data available for determining the probabilities of recurrent VTE, bleeding, post-thrombotic syndrome, and risk of death due to PE with recurrent VTE for patients with first episode idiopathic DVT. The WODIT trial may provide some of this data but still has been published in abstract form only and therefore has not been subjected to rigorous peer review (16).

The second issue raised by this analysis relates to the utilities for post-thrombotic syndrome and oral anticoagulant therapy. This study was the first to elicit a utility for oral anticoagulant therapy in patients with VTE. We obtained a utility mean of 0.928 and median of 0.980 for oral anticoagulant therapy in this population. Previously published utilities for oral anticoagulant therapy have ranged from 0.996-1 in patients on coumarins for atrial fibrillation. Both the present analysis and those by Marchetti and van den Belt (37,40) have concluded that very small variations in patient perception of the burden of anticoagulant therapy have huge impact on treatment strategies. This also applies to the utility for moderate-to-severe post-thrombotic syndrome. Ours was the first study to elicit this value in patients with VTE. The mean and median utilities for this outcome were 0.809 and 0.840 respectively compared to the median value of 0.95 obtained by Lenert which was elicited in healthy volunteers with a median age of 35 (44). Our decision analysis demonstrated that if patients assign a relatively low utility to post-thrombotic syndrome (less than 0.80), then longer durations of anticoagulant therapy are better.

Krahn et al have suggested there are several other post-analytic issues to consider before making firm conclusions about the decision offered by a model (11). The first is the issue of cost. Thus in the case of a clinical “toss up”, one strategy may clearly be less costly than the other. That strategy would then become the more attractive one and there is no longer a “toss up”. This is particularly applicable to the present model because the strategies are quite similar in terms of life expectancy and quality-adjusted life expectancy. This question will be addressed in a future project that has been submitted for peer-reviewed funding.

The second issue is one of risk. Thus if one strategy has a greater chance of adverse outcomes, the less risky strategy may be preferred by most patients. A small gain for many patients would produce the same result as a mixture of larger gains and losses, thus the distribution of gains and losses may not be reflected in the results of an analysis. This is also applicable to our model, as some patients may not wish to assume even a small risk of death secondary to recurrent VTE by choosing shorter-term anticoagulation.

The third issue relates to the ethical consequences of application of the results of a decision analysis. This is because some patients may be exposed to great losses so that others may achieve gains. Thus in a situation where the overall difference between strategies is small, one must consider if one of the strategies has more “big losers” than in other strategies.

The fourth issue is one of time. As with some clinical trials, conclusions of analyses that only look at short durations of time may miss differences in strategies that are not be apparent within the time period studied. This is not applicable to our model as we used a Markov model that included the patient’s entire life expectancy. In simple, non-Markov models this can be an issue as there may be events beyond the time frame of the model that might affect the strategy that is preferred. This has been a weakness of previous decision analyses in this area.

The fifth issue relates to one of the interests of others. This model examines the outcomes from the patient’s point of view and does not examine the impact of illness and death on family, friends, the health-care system and society. Some of these issues as they relate to our analysis will be explored in a future full economic analysis but it is unlikely

one will ever be able to fully capture the emotional impact of patient outcomes on family, friends and society.

The present analysis has some limitations. First, it was based on data from literature that was limited. There has been only one published randomized trial on the duration of therapy in first episode idiopathic DVT and as a result, much of the data was obtained from multiple sources, by using interpolation or from populations that were not identical to the one of interest. Second, the rates of bleeding and recurrent VTE generally reflected those patients who are followed in a thrombosis unit and may not reflect those observed in the community. Third, the necessary assumptions may not apply to all patients and options like reduced intensity anticoagulation were not considered. A fourth limitation relates to the description of the state of being on oral anticoagulant therapy. It is possible that some individuals may indeed perceive a burden from not being on therapy as the use of anticoagulants may provide a sense of protection against recurrent VTE. Therefore it may be useful to elicit the utility for oral anticoagulant therapy with and without description of its use as secondary prophylaxis against recurrent VTE to see if this does indeed affect its value.

In conclusion, the results of our analysis have demonstrated that the decision as to how long to anticoagulate patients with first episode idiopathic DVT is largely influenced by the patient's perceived health burden of oral anticoagulant therapy. A small effect of the burden of treatment on quality of life strongly influences the optimal duration of treatment. The base-case analysis suggests that if there is any perceived burden associated with anticoagulant therapy, then shorter duration therapy is preferred. The results of this analysis provide a unique opportunity to tailor the duration of anticoagulant

therapy to individual patients based on the considerations presented. The decision to continue treatment will be therefore be influenced by the patient's appreciation of the burden of anticoagulant therapy and to some extent the burden of post-thrombotic syndrome as well as the physician's estimation of individual risk for bleeding and recurrent VTE.

**Appendix 1: Volunteer poster**

**VOLUNTEERS**

**Deep Vein Thrombosis Study**

• Being healthy means to  
 • **Respect your preferences**  
 • **so this can be**  
 • **care decisions**  
 • **of your time so we**  
 • **health care**  
 • **computer-assisted**

• **people (age 43-75) who have**  
 • **thrombosis and who are**

**PLEASE CONTACT**

• **760-5655 extension 3769**  
 • **@mail.com**



**Appendix 3: Health Utilities Index (HUI) Mark III**

<b>Attribute</b>	<b>Level</b>	<b>Description</b>
<b>VISION</b>	1	Able to see well enough to read ordinary newsprint and recognize a friend on the other side of the street, without glasses or contact lenses.
	2	Able to see well enough to read ordinary newsprint and recognize a friend on the other side of the street, but with glasses.
	3	Able to see well enough to read ordinary newsprint, but unable to recognize a friend on the other side of the street, even with glasses.
	4	Able to recognize a friend on the other side of the street, with or without glasses, but unable to read ordinary newsprint, even with glasses.
	5	Unable to read ordinary newsprint and unable to recognize a friend on the other side of the street, even with glasses.
	6	Unable to see at all.
<b>HEARING</b>	1	Able to hear what is said in a group conversation with at least three other people, without a hearing aid.
	2	Able to hear what is said in a conversation with one other person in a quiet room without a hearing aid, but requires a hearing aid to hear what is said in a group conversation with at least three other people.
	3	Able to hear what is said in a conversation with one other person in a quiet room with a hearing aid, and able to hear what is said in a group conversation with at least three other people with a hearing aid.
	4	Able to hear what is said in a conversation with one other person in a quiet room without a hearing aid, but unable to hear what is said in a group conversation with at least three other people even with a hearing aid.
	5	Able to hear what is said in a conversation with one other person in a quiet room with a hearing aid, but unable to hear what is said in a group conversation with at least three other people even with a hearing aid.
	6	Unable to hear at all.
<b>SPEECH</b>	1	Able to be understood completely when speaking with strangers or friends.
	2	Able to be understood partially when speaking with strangers but able to be understood completely when speaking with people who know me well.
	3	Able to be understood partially when speaking with strangers or

		<b>people who know me well.</b>
	<b>4</b>	<b>Unable to be understood when speaking to strangers but able to be understood partially by people who know me well.</b>
	<b>5</b>	<b>Unable to be understood when speaking to other people (or unable to speak at all).</b>
<b>Ambulation</b>	<b>1</b>	<b>Able to walk around the neighbourhood without difficulty, and without walking equipment.</b>
	<b>2</b>	<b>Able to walk around the neighbourhood with difficulty, but does not require walking equipment or the help of another person.</b>
	<b>3</b>	<b>Able to walk around the neighbourhood with walking equipment, but without the help of another person.</b>
	<b>4</b>	<b>Able to walk only short distances with walking equipment, and requires a wheelchair to get around the neighbourhood</b>
	<b>5</b>	<b>Unable to walk alone, even with walking equipment. Able to walk short distances with the help of another person, and requires a wheelchair to get around the neighbourhood</b>
	<b>6</b>	<b>Cannot walk at all.</b>
<b>Dexterity</b>	<b>1</b>	<b>Full use of two hands and ten fingers.</b>
	<b>2</b>	<b>Limitations in the use of hands or fingers, but does not require special tools of help of another person.</b>
	<b>3</b>	<b>Limitations in the use of hands or fingers, is independent with use of special tools (does not require the help of another person).</b>
	<b>4</b>	<b>Limitations in the use of hands or fingers, requires the help of another person for some tasks (not independent even with use of special tools)</b>
	<b>5</b>	<b>Limitations in the use of hands or fingers, requires the help of another person for most tasks (not independent even with use of special tools)</b>
	<b>6</b>	<b>Limitations in the use of hands or fingers, requires the help of another person for all tasks (not independent even with use of special tools)</b>
<b>Emotion</b>	<b>1</b>	<b>Happy and interested in life.</b>
	<b>2</b>	<b>Somewhat happy.</b>
	<b>3</b>	<b>Somewhat unhappy.</b>
	<b>4</b>	<b>Very unhappy.</b>
	<b>5</b>	<b>So unhappy that life is not worthwhile.</b>
<b>Cognition</b>	<b>1</b>	<b>Able to remember most things, think clearly and solve day to day problems.</b>
	<b>2</b>	<b>Able to remember most things, but has a little difficulty when trying to think and solve day to day problems.</b>
	<b>3</b>	<b>Somewhat forgetful, but able to think clearly and solve day to day</b>

**problems.**

- 4 Somewhat forgetful, and has a little difficulty when trying to think or solve day to day problems.**
- 5 Very forgetful, and has great difficulty when trying to think or solve day to day problems.**
- 6 Unable to remember anything at all, and unable to think or solve day to day problems.**

**Pain**

- 1 Free of pain and discomfort.**
- 2 Mild to moderate pain that prevents no activities.**
- 3 Moderate pain that a few activities.**
- 4 Moderate to severe pain that prevents some activities.**
- 5 Severe pain that prevents most activities.**

**Appendix 4: Health state descriptions****A: Perfect health**

- Vision:** Able to see well enough to read ordinary newsprint and recognize a friend on the other side of the street, without glasses or contact lenses.
- Hearing:** Able to hear what is said in a group conversation with at least three other people, without a hearing aid.
- Speech:** Able to be understood completely when speaking to strangers or friends.
- Ambulation:** Able to walk around the neighborhood without difficulty, and without walking equipment.
- Dexterity:** Able to enjoy full use of two hands and ten fingers.
- Mood:** Happy and interested in life.
- Cognition:** Able to remember most things, think clearly and solve day to day problems.
- Pain:** Free of pain and discomfort.



**B: Oral anticoagulant therapy****CONDITION "X"**

You are on a medication that thins your blood. You need to have regular and sometimes frequent bloodtests (every 2-4 weeks) to determine how thin your blood is and to ensure you receive the appropriate dose. You will have to notify your doctor if you are taking any other medications as they may interfere with the blood thinning medication. If you cut yourself, you may bleed more than usual. You will need to notify your doctor if you are going to the dentist or are going to have surgery so that the medication can be adjusted for the surgery. You have a very small risk-about 1 person per year- of life-threatening bleeding. You will be able to continue all of your physical activities but should avoid body contact sports or other activities in which injuries are more likely to occur. You will need to avoid fad diets or any diet radically different from your usual diet. You will be limited to 1-2 alcoholic beverages per day.

**Vision:** You are able to see well enough to read ordinary newsprint and recognize a friend on the other side of the street, without glasses or contact lenses.

**Hearing:** You are able to hear what is said in a group conversation with at least three other people, without a hearing aid.

**Speech:** You are able to be understood completely when speaking to strangers or friends.

**Ambulation:** You are able to walk around the neighborhood without difficulty, and without walking equipment.

**Dexterity:** You have full use of two hands and ten fingers.

**Emotion:** You are happy and interested in life.

**Cognition:** You are able to remember most things, think clearly and solve day to day problems.

**Pain:** You are free of pain and discomfort.

**C: Mild post-thrombotic syndrome****CONDITION “Y”**

Your leg is often slightly swollen. The skin on your leg is slightly darker than the other leg and sometimes shiny. The swelling can sometimes be complicated by a skin infection that requires antibiotics. Your leg looks different from your normal leg. You will need to wear a stocking on your leg to prevent the swelling from getting worse. The stocking may be hot and feel slightly tight. Your leg occasionally aches at the end of the day.

**Vision:** You are able to see well enough to recognize a friend on the other side of the street, without glasses or contact lenses.

**Hearing:** You are able to hear what is said in a group conversation with at least three other people, without a hearing aid.

**Speech:** You are able to be understood completely when speaking to strangers or friends.

**Ambulation:** You are able to walk around the neighborhood without difficulty, and without walking equipment.

**Dexterity:** You have full use of two hands and ten fingers.

**Emotion:** You are happy and interested in life.

**Cognition:** You are able to remember most things, think clearly and solve day to day problems.

**Pain:** You have mild to moderate pain that prevents no activities.

**D: Moderate to severe post-thrombotic syndrome****CONDITION "Z"**

**You have a permanently swollen leg. The skin on your leg is discolored and shiny. You frequently have skin ulcerations that are painful and may take months to heal. These ulcerations need daily dressing changes and require frequent visits to the doctor or frequent visits from Homecare nurses. The leg swelling and pain may cause limitations in your ability to walk or stand for prolonged amounts of time. You will have to wear elastic stocking every day. The stocking may be hot and feel slightly tight.**

**Vision:** You are able to see well enough to read ordinary newsprint and recognize a friend on the other side of the street, without glasses or contact lenses.

**Hearing:** You are able to hear what is said in a group conversation with at least three other people, without a hearing aid.

**Speech:** You are able to be understood completely when speaking to strangers or friends.

**Ambulation:** You are able to walk around the neighborhood with difficulty, but do not require walking equipment or the help of another person.

**Dexterity:** You have full use of two hands and ten fingers.

**Emotion:** You are somewhat unhappy.

**Cognition:** You are able to remember most things, think clearly and solve day to day problems.

**Pain:** You have moderate to severe pain that prevents some activities.

**E: Permanent neurologic sequelae secondary to intracranial hemorrhage****CONDITION “Q”**

**You are in a wheelchair and unable to use the right side of your body. You cannot talk or understand what is being said to you. You are unable to write or read. You rely on assistance for most of your daily activities such as bathing or dressing.**

**Vision:** You are able to see well enough to recognize a friend on the other side of the street, without glasses or contact lenses.

**Hearing:** You are able to hear what is said in a group conversation with at least three other people without a hearing aid.

**Speech:** You are unable to be understood when speaking to other people (or unable to speak at all).

**Ambulation:** You cannot walk at all.

**Dexterity:** You have limitations in the use of your hands and fingers, and require the help of another person for most tasks.

**Emotion:** You are very unhappy.

**Cognition:** You are very forgetful, and have great difficulty when trying to think or solve day to day problems.

**Pain:** You have moderate pain that prevents a few activities.

**Appendix 5: Sample of computerized standard gamble**

**A:**

Imagine you are in the state of health that was described to you.

**Choice B**

<p>Health</p> <p>15% chance of FAILURE</p> <p>DIE painlessly today</p>	<p>Health</p> <p>Death</p>	<p>Live with <b>CONDITION Z</b> for the rest of your life.</p>
--	----------------------------	--

**Choice C**

CONDITION B are about

same to me.

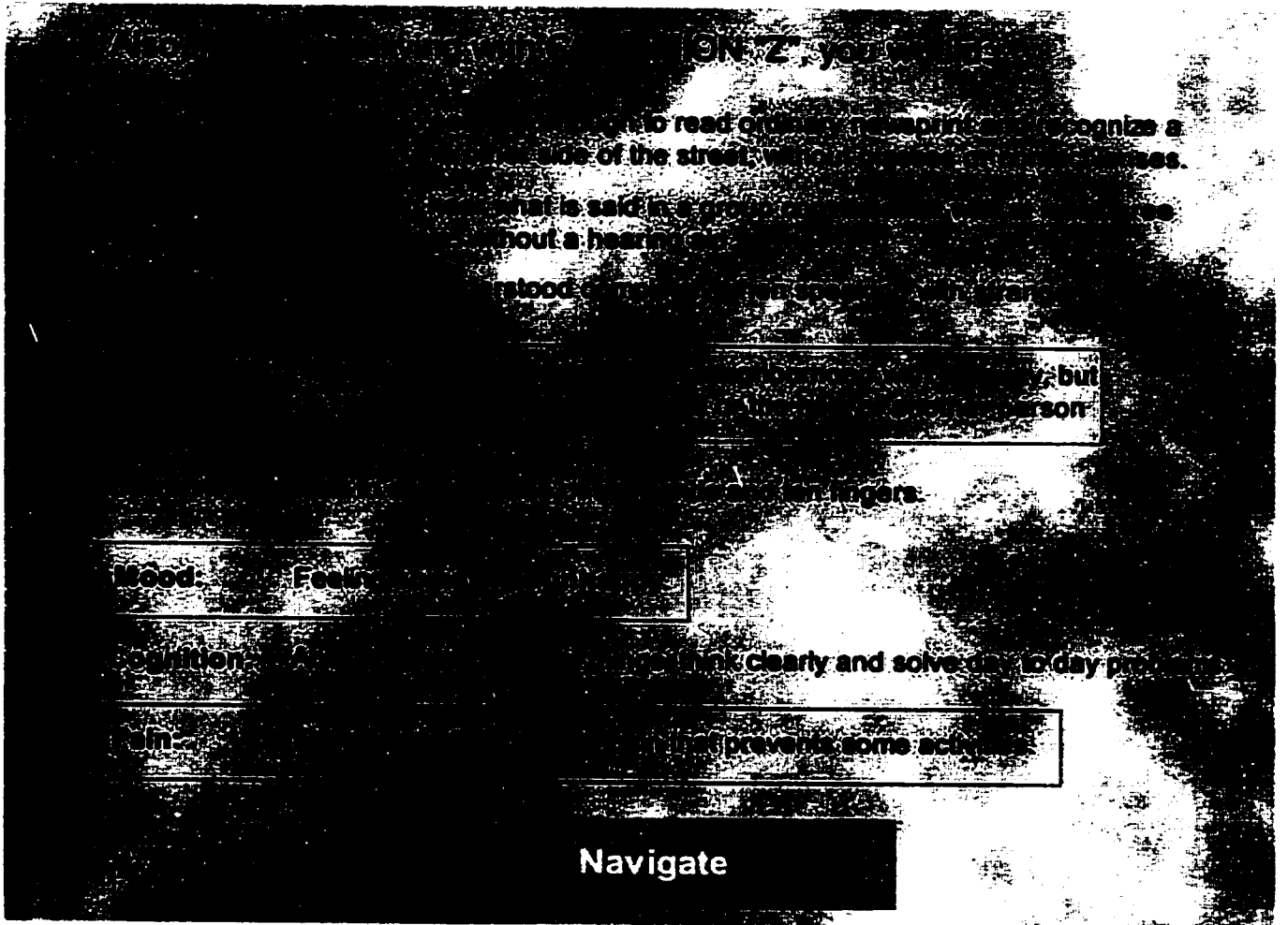

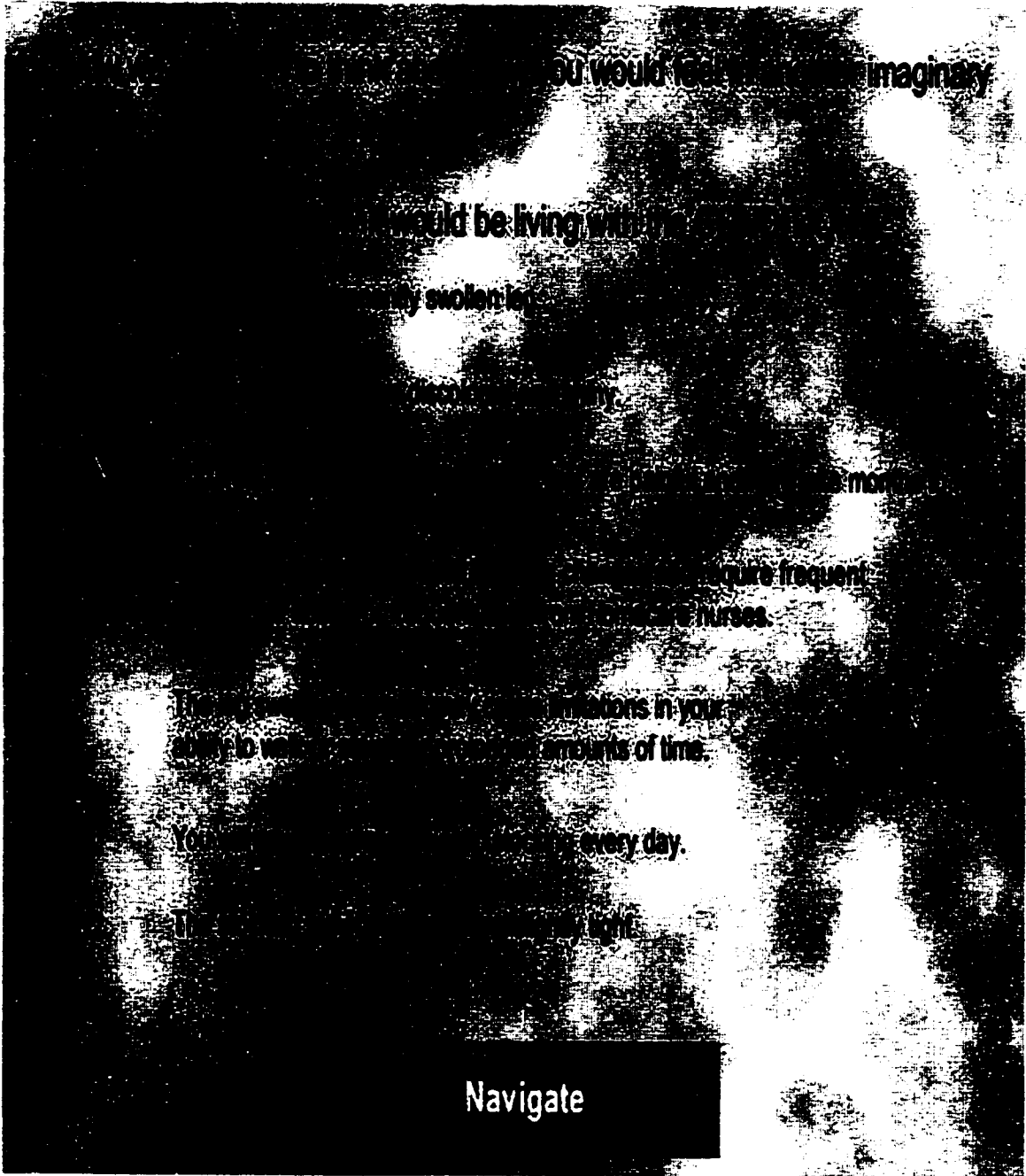

**Appendix 6: Respondent consent for utility collection****INFORMED CONSENT AND PATIENT INFORMATION  
To participate in a Medical Research Study**

**TITLE OF STUDY:** Computerized elicitation of utilities for health states associated with venous thromboembolism

**INVESTIGATOR NAME:** Dr. Melissa Forgie, 613-761-4127

**PURPOSE OF THE STUDY:** You are being asked to participate in a research study to determine patient preferences for different treatment options in deep vein thrombosis. At the present time, the optimum duration of anticoagulant therapy ranges from 6 months to two years. Until now, patient preferences and quality of life have not been factored into the decision between different durations of treatment. This study will help us to include patient preferences into this decision. The study is a questionnaire about how people feel about the quality of life experienced by patients with blood clots in their leg vein.

**DESCRIPTION OF THE STUDY:** The study consists of an interview. The questionnaire will consist of a 30-minute interview conducted by an interactive computer. A member of the thrombosis unit will be present to assist you with the computer. The computer will describe a series of health states and then ask you a series of questions.

**STUDY PROCEDURES:** If you choose to participate in this study, you will be asked to sign a copy of this informed consent. You will then be asked to read four descriptions describing a person's life on anticoagulant therapy, a person's life with post thrombotic syndrome and a person's life who has had a major bleeding event. You will then be asked to rank your preference for each of these health states. The computer will guide you through a series of questions and choices about these health states. A member of the Thrombosis Unit will be with you during the interview to assist you with the computer and the questions. You will be asked to record your initials, date of birth, gender, how long (if any) you have been on anticoagulants and any other significant medical conditions you may have. The interview will be carried out in English.

**RISKS/BENEFITS:** The study consists of an interview only. There will be no potential risks to participating in the study. Your participation will help us to understand how patients feel about taking anticoagulants and the complications of treatment and deep vein thrombosis.

**STUDY PARTICIPATION:** Your participation in this study is entirely voluntary. If you choose not to participate, you will continue to receive the usual care provided by your regular physicians.

**WITHDRAWAL FROM STUDY:** If you choose to participate you are free to withdraw from this study at any time.

**CONFIDENTIALITY:** All results of this study will be kept confidential. Your name or any material identifying you as a study participant will not be released. You will not be identifiable in any publication or presentation resulting from this study.

**INDEPENDENT REVIEW:** The Research Ethics Board of this hospital has reviewed and approved this research study.

**INFORMATION:** If you have any questions regarding this study you may contact Dr. Forgie at 613-761-4127. If you desire or want any further information regarding your rights as a subject participating in a research study, you may contact the Chairman of the Research Ethics Board of the Ottawa Hospital at 613-761-5072.

**AGREEMENT TO PARTICIPATE IN STUDY/SIGNATURE:** My signature below indicates that I have read all of the above information about this research study. The content and meaning of this information have been explained and are understood. I have had the opportunity to ask questions. I have been given a copy of this informed consent.

Patient Signature \_\_\_\_\_ Date \_\_\_\_\_

Patient's name (please print) \_\_\_\_\_

I have explained the above to the participant on the date stated on this Informed Consent.

Investigator's signature \_\_\_\_\_ Date \_\_\_\_\_

Witness's signature \_\_\_\_\_ Date \_\_\_\_\_

Witness's name (please print) \_\_\_\_\_

**Appendix 7: Research protocol approval**

Tuesday, January 04, 2000

Dr. Melissa Forgie  
Division of Hematology  
Room 468, Civic Parkdale Clinic  
Ottawa Hospital-Civic Campus

Dear Dr. Forgie:

**Re: Protocol # - 1999344-01H    Computerized Elicitation of Utilities for Health States Associated with Venous Thromboembolism**

**Protocol approval valid until -    Wednesday, January 03, 2001**

I am pleased to inform you that your study (listed above) and the Informed Consent and Patient Information Sheet dated version 08/12/99 were given expedited review by the Ottawa Hospital Research Ethics Board (OHREB) and approved. No changes, amendments or addenda may be made in the protocol or the consent form without the OHREB review and approval.

The validation date should be indicated on the bottom of all consent forms and information sheets (see copy attached). Approximately one month prior to the expiration date listed above, a single renewal form should be sent to the Research Services Office.

Guidelines of the Medical Research Council require a greater involvement of the Research Ethics Board in studies over the course of their execution. You must maintain as part of your records copies of the signed consent form. As well, you must inform the Board of adverse events encountered during the study, here or elsewhere, or of significant new information, which becomes available after the Board review either of which may impinge on the ethics of continuing the study. The OHREB will review the new information to determine if the protocol should be modified, discontinued, or should continue as originally approved.

Yours sincerely,

Raphael Saginur, M.D.  
Chairman  
Ottawa Hospital Research Ethics Board

Encl.

**Appendix 8: Search strategy for randomized trials on duration of therapy in deep vein thrombosis**

- 1 exp Thrombophlebitis/or DVT.mp or exp Venous Thrombosis/or exp Thrombosis (73502)
- 2 exp Anticoagulants/or anticoagulant therapy.mp. or exp Coumarins/or exp Warfarin (95244)
- 3 1 and 2 (14364)
- 4 exp randomized controlled trials/or randomized.mp. (89093)
- 5 3 and 4 (806)

**Appendix 9: Search strategy for bleeding secondary to oral anticoagulants**

- 1 exp Warfarin/or warfarin.mp. (7681)
- 2 exp COUMARINS (15125)
- 3 1 or 2 (16807)
- 4 exp Hemorrhage/or bleeding.mp. (156352)
- 5 3 and 4 (322)

**REFERENCES**

1. Hirsh J, Ginsberg JS, Marder VJ. Colman RW, Hirsh J, Marder VJ, editors. Hemostasis and Thrombosis : Basic principles and clinical practice. third ed. Philadelphia: J.B. Lippincott Company; 1994; 82, Anticoagulant therapy with coumarin agents. p. 1567-83.
2. Valentine KA, Hull RD. Advances in anticoagulant management of thromboembolism. *Can J CME* 1998;77-87.
3. Kearon C. Two years of Warfarin versus placebo following three months of anticoagulation for a first episode of idiopathic thromboembolism (VTE). [Abstract] *Thrombosis & Haemostasis* 1997;Supplement:(June)767
4. Petiti DB, Strom BL, Melmon KL. Duration of warfarin anticoagulant therapy and the probabilities of recurrent thromboembolism and hemorrhage. *Am J Med* 1986;81:255-9.
5. Schulman S, Lockner D, Juhlin-Dannfelt A. The duration of oral anticoagulation after deep vein thrombosis. *Acta Med Scand* 1985;217(5):547-52.
6. Holmgren K, Andersson G, Fagrell B, Johnsson H, Ljungberg B, Nilsson E, Wilhelmsson S, Zetterquist S. One-month versus six-month therapy with oral anticoagulants after symptomatic deep vein thrombosis. *Acta Med Scand* 1985;218:279-84.
7. Fennerty A, Campbell IA. Anticoagulants in venous thromboembolism. Guidelines for optimum treatment. *BMJ* 1988;297:1285-8.
8. Moser KM. Venous thromboembolism. *Am Rev Resp Dis* 1990;141:235-49.
9. Research Committee of the British Thoracic Society, Campbell IA, Sudlow MF, Angel JH, Bentley DP, Fennerty AG, Prescott RJ, Routledge PA. Optimum duration of anticoagulation for deep-vein thrombosis and pulmonary embolism. *Lancet* 1992;340:873-6.
10. Naglie G, Krahn MD, Naimark D, Redelmeier DA, Detsky AS. Primer on medical decision analysis: Part 3 -- Estimating probabilities and utilities. *Med Dec Making* 1997;17:136-41.
11. Krahn MD, Naglie G, Naimark D, Redelmeier DA, Detsky AS. Primer on medical decision analysis: Part 4 -- Analyzing the model and interpreting the results. *Med Dec Making* 1997;17:142-51.

12. Naimark D, Krahn MD, Naglie G, Redelmeier DA, Detsky AS. Primer on medical decision analysis : Part 5 - Working with Markov Processes. *Med Dec Making* 1997;17:152-9.
13. Veronesi U, Maisonneuve P, Costa A, Sacchini V, Maltoni C, Robertson C, Rotmensz N, Boyle P. Prevention of breast cancer with tamoxifen: preliminary findings from the Italian randomised trial among hysterectomised women. *Lancet* 1998;352:93-7.
14. Powles T, Eeles R, Ashley S, Easton D, Chang J, Dowsett M, Tidy A, Viggers J, Davey J. Interim analysis of the incidence of breast cancer in the Royal Marsden Hospital tamoxifen randomised chemoprevention trial. *Lancet* 1998;352:98-101.
15. Kearon C, Gent M, Hirsh J, Weitz J, Kovacs MJ, Anderson DR, Turpie AG, Green D, Ginsberg JS, Wells PS, et al. A comparison of three months of anticoagulation with extended anticoagulation for a first episode of idiopathic venous thromboembolism. *N Engl J Med* 1999;340(12):901-7.
16. Agnelli G, Prandoni P, Santamaria MG, et al. Three-months compared with one-year of oral anticoagulant treatment after a first idiopathic deep vein thrombosis: The warfarin optimal duration Italian trial (WODIT). [Abstract] *Thromb Haemost* 1999;Suppl:684
17. Schulman S, Rheden AS, Lindmarker P, Carlsson A, Larfars G, et al. A Comparison of six weeks with six months of oral anticoagulant therapy after a first episode of venous thromboembolism. *N Engl J Med* 1995;332(25):1661-5.
18. Fennerty AG, Dolben J, Thomas P, Backhouse G, Bentley DP, Campbell IA, Routledge PA. A comparison of 3 and 6 weeks' anticoagulation in the treatment of venous thromboembolism. *Clin Lab Haemat*. 1987;9:17-21.
19. Lohr JM, Kerr TM, Lutter KS, Cranley RD, Spirtoff K, Cranley JJ. Lower extremity calf thrombosis: to treat or not to treat? *J Vasc Surg* 1991;14(5):618-23.
20. Lindholm C, Bjellerup M, Christensen OB, Zederfeldt B. Quality of life in chronic leg ulcer patients: an assessment according to the Nottingham health profile. *Acta Derm Venereol* 1993;73:440-3.
21. Philips T, Stanton B, Provan A, Lew R. A study of the impact of leg ulcers on quality of life : financial, social, and psychologic implications. *J Am Acad Dermatol* 1994;31:49-53.
22. Beyth RJ, Cohen AM, Landefeld CS. Long term outcomes of deep-vein thrombosis. *Arch Int Med* 1994;155:1031-7.

23. Prandoni P, Lensing AW, Cogo A, et al. Symptomatic deep vein thrombosis and the post thrombotic syndrome. [Abstract] *Thromb Haemost* 1993;69:1211
24. Vandenbroucke JP, Bertina RM, Holmes ZR, Spaargaren C, van Krieken JHJM, Manten B, Reitsma PH. Factor V Leiden and fatal pulmonary embolism. *Thromb Haemost* 1998;79:511-6.
25. Heymans S, Verhaeghe R, Stockx L, Collen D. Feasibility study of catheter-directed thrombolysis with recombinant staphylokinase in deep vein thrombosis. *Thromb Haemost* 1998;79:517-9.
26. Oxman AD, Thomson MA, Davis DA, Haynes RB. No magic bullets : a systematic review of 102 trials of interventions to improve professional practice. *Can Med Assoc J* 1995;153(10):1423-31.
27. Prandoni P, Lensing AWA, Cogo A, Cuppini S, Villalta S, Carta M, Cattelan AM, Polistena P, Bernardi E, Prins M. The long-term clinical course of acute deep venous thrombosis. *Ann Intern Med* 1996;125(1):1-7.
28. Sox HC; Blatt MA; Higgins MC, et al. *Medical Decision Making*. Newton,MA: Butterworth-Heinemann; 1988.
29. Furlong, W., Feeny, D., Torrance, G.W., and Horsman, J. *Guide to design and development of health state utility instrumentation*. 1990.
30. Sarasin FP, Bounameaux H. Duration of oral anticoagulant therapy after proximal deep vein thrombosis: a decision analysis. *Thromb Haemost* 1994;71(3):286-91.
31. Prandoni P, Lensing AWA, Buller HR, Cogo A, Prins MH, Cattelan AM, Cuppini S, Noventa F, ten Cate JW. Deep-vein thrombosis and the incidence of subsequent symptomatic cancer. *N Engl J Med* 1992;327(16):1128-33.
32. Levine MN, Hirsh J, Gent M, Turpie AG, Weitz J, Ginsberg J, Geerts W, LeClerc J, Neemeh J, Powers P, et al. Optimal duration of oral anticoagulant therapy: A randomized trial comparing four weeks with three months of Warfarin in patients with proximal deep vein thrombosis. *Thromb Haemost* 1995;74(2):606-11.
33. Beck JR, Kassirer JP, Pauker SG. A Convenient approximation of life expectancy. (The DEALE) I. Validation of the method. *Am J Med* 1982;73:883-8.
34. van Pampus MG, Koopman MMW, Wolf H, Buller HR, Prins MH, van den Ende A. Lipoprotein(a) concentrations in women with a history of severe preeclampsia - a case control study. *Thromb Haemost* 1999;82:10-3.

35. Douketis JD, Kearon C, Bates S, Duku EK, Ginsberg JS. Risk of fatal pulmonary embolism in patients with treated venous thromboembolism. *JAMA* 1998;279(6):458-62.
36. Sarasin FP, Bounameaux H. Decision analysis model of prolonged oral anticoagulant treatment in factor V Leiden carriers with first episode of deep vein thrombosis. *BMJ* 1998;316:95-9.
37. Marchetti M, Pistorio A, Barosi G. Extended anticoagulation for prevention of recurrent venous thromboembolism in carriers of Factor V Leiden. Cost effectiveness analysis. *Thromb Haemost* 2000;84:752-7.
38. Ridker PM, Miletich JP, Stampfer MJ, Goldhaber SZ, Lindpaintner K, Hennekens CH. Factor V Leiden and risks of recurrent idiopathic venous thromboembolism. *Circulation* 1995;92:2800-2.
39. Prins MH, van den Belt AGM, Hutten BA, et al. Duration of oral anticoagulant treatment in patients with venous thromboembolism and a deficiency of antithrombin, Protein C or Protein S : A decision analysis. [Abstract] *Thromb Haemost* 1999;Suppl:180.
40. van den Belt AGM, Hutten BA, Prins MH, Bossuyt PMM. Duration of oral anticoagulant treatment in patients with venous thromboembolism and deficiency of antithrombin protein C or protein S - A decision analysis. *Thromb Haemost* 2000;84:758-63.
41. Prins MH, Hutten BA, Koopman MMW, Buller HR. Long-term treatment of venous thromboembolic disease. *Thromb Haemost* 1999;State of the Art:892-8.
42. Prins MH, Hutten BA, Koopman MMW, et al. The optimal duration of secondary prevention with oral anticoagulants in patients with venous thromboembolism: A decision analysis. [Abstract] *ISH 99 abstracts* 1999.
43. O'Meara JJ, McNutt RA, Evans AT, Moore SW, Downs SM. A decision analysis of streptokinase plus heparin as compared with heparin alone for deep vein thrombosis. *N Engl J Med* 1994;330:1864-9.
44. Lenert LA, Soetikno RM. Automated computer interviews to elicit utilities: Potential applications in the treatment of deep venous thrombosis. *JAMA* 1997;4(1):49-56.
45. Gage BF, Cardinali AB, Owens DK. The effect of stroke and stroke prophylaxis with aspirin or warfarin on quality of life. *Arch Int Med* 1996;156:1829-36.

46. Miyamoto JM, Eraker SA. Parameter estimates for QALY utility model. *Med Dec Making* 1985;5:191-213.
47. Clarke AE, Goldstein MK, Michelson D, Garber AM, Lenert LA. The effect of assessment method and respondent population on utilities elicited for Gaucher Disease. *Quality of Life Research* 1997;6:169-84.
48. Sackett DL, Torrance GW. The utility of different health states as perceived by the general public. *J Chron Dis* 1978;31:697-704.
49. Llewellyn-Thomas HA, Sutherland HJ, Thiel EC. Do patients' evaluations of a future health state change when they actually enter that state? *Med Care* 1993;31(11):1002-12.
50. O'Connor A. Effects of framing and level of probability on patients' preferences for cancer chemotherapy. *J Clin Epidemiol* 1989;42:119-26.
51. Hanson EW, Lowson SM. Atrial Fibrillation and thromboembolism. *Anesth Analg* 1998;87:217-23.
52. Kolecki RV, Sigel B, Justin J, Feleppa EJ, Parsons RE, Kitamura H, Machi J, Hayashi J, Taylor P, McGann L, et al. Determining the acuteness and stability of deep venous thrombosis by ultrasonic tissue characterization. *J Vasc Surg* 1995;21:976-84.
53. Leroyer C, Mercier B, Oger E, Chenu E, Abgrall J-F, Ferec C, Mottier D. Prevalence of 20210A allele of the prothrombin gene in venous thrombosis patients. *Thromb Haemost* 1998;80(1):49-51.
54. Robert A, Le Querrec A, Delahousse B, Caron C, Houbouyan L, Boutiere B, Horellou MH, Reber G, Sie P. Control of oral anticoagulation in patients with the antiphospholipid syndrome - Influence of the lupus anticoagulant on International Normalized Ratio. *Thromb Haemost* 1998;80(1):99-103.
55. Van der Meer FJM, Rosendaal FR, Vandenbroucke JP, Briet E. Assessment of a bleeding risk index in two cohorts of patients treated with oral anticoagulants. *Thromb Haemost* 1996;76(1):12-6.
56. Fihn SD, McDonell M, Martin D, Henikoff J, Vermes D, Kent D, White RH. Risk factors for complications of chronic anticoagulation. A multicenter study. *Ann Intern Med* 1993;118(7):511-20.
57. Holm HA, Abildgaard U, Kalvenes S. Heparin assays and bleeding complications in treatment of deep venous thrombosis with particular reference to retroperitoneal bleeding. *Thromb Haemost* 1985;278-81.
58. Palareti G, Manotti C, D'Angelo A, Pengo V, Erba N, Moia M, Ciavarella N, Devoto G, Berrettini M, Leali N, et al. Thrombotic events during oral

- anticoagulant treatment: results of the inception-cohort, prospective, collaborative ISCOAT Study. *Thromb Haemost* 1997;78(6):1438-43.
59. Beck JR, Pauker SG. The Markov Process in medical prognosis. *Med Dec Making* 1983;3(4):419-58.
  60. Mehrez A, Gafni A. The healthy years equivalents: How to measure them using the standard gamble approach. *Med Dec Making* 1991;11:140-6.
  61. Schulman S, Granqvist S, Holmstrom M, Carlsson A, Lindmarker P, Nicol P, Eklund SG, Nordlander S, Larfars G, Leijd B, et al. The duration of oral anticoagulant therapy after a second episode of venous thromboembolism. *N Engl J Med* 1997;336(6):393-8.
  62. Detsky AS, Naglie G, Krahn MD, Redelmeier DA, Naimark D. Primer on medical decision analysis: Part 2 -- Building a tree. *Med Dec Making* 1997;17:126-35.
  63. Treeage Software Inc. DATA 3.5 healthcare user's manual. 3.5 ed. Williamstown, MA: Treeage Software Inc.; 1999.
  64. Prandoni P, Villalta S, Polistena P, Bernardi E, Cogo A, Girolami A. Symptomatic deep-vein thrombosis and the post-thrombotic syndrome. *Haematologica* 1995;80(2 suppl):42-8.
  65. Hyers TM, Hull RD, Weg JG. Antithrombotic therapy for venous thromboembolic disease. *Chest* 1995;108(4):335S-51S.
  66. Canadian Coordinating Office for Health Technology Assessment. Guidelines for economic evaluation of pharmaceuticals: Canada. 2nd ed. Ottawa: 1997;Measuring and reporting costs. p. 39-45.
  67. Lipscomb J, Weinstein MC, Torrance GW, Gold MR, Siegel EL, Russell LB, Weinstein MC, editors. Cost-effectiveness in health and medicine. New York: Oxford University Press; 1996;Time preference. p. 214-46.
  68. Beck JR, Pauker SG, Gottlieb JE, Klein K, Kassirer JP. A Convenient approximation of life expectancy. (The DEALE) II. Use in medical decision making. *Am J Med* 1982;73:889-97.
  69. Dolan P. Whose preferences count? *Med Dec Making* 1999;19(4):482-6.
  70. Meyerowitz BE. Postmastectomy coping strategies and quality of life. *Health Psychol* 1983;2(2):117-32.
  71. Cassileth BR, Lusk EJ, Strouse TB, Miller DS, Brown LL, Cross PA, Tenaglia MA, Tenaglia AN. Psychosocial status in chronic illness: a comparative analysis of six diagnostic groups. *N Engl J Med* 1984;311:506-11.

72. Edgar A; Salek S; Shickle D, et al. **The ethical QALY: ethical issues in healthcare resource allocations.** Haslemere, UK: Euromed Communications; 1998.
73. Hart RG, Benavente O, McBride R, Pearce LA. **Antithrombotic therapy to prevent stroke in patients with atrial fibrillation: A Meta-analysis.** *Ann Intern Med* 1999;131:492-501.
74. Shott S. **Statistics for health professionals.** 1st ed. Philadelphia, PA: W.B. Saunders Co; 1990.
75. Torrance GW, Feher J. **Utilities and quality-adjusted life years.** *Int J Technol Assess Health Care* 1989;5:559-75.
76. Froberg DG, Kane RL. **Methodology for measuring health-state preferences - II: Scaling methods.** *J Clin Epidemiol* 1989;42:459-71.
77. Gafni A. **Willingness-to-pay as a measure of benefits: Relevant questions in the context of public decision making about health care programs.** *Med Care* 1991;29(12):1246-52.
78. Goldstein MK, Clarke AE, Michelson D, Garber AM, Bergen MR, Lenert LA. **Developing and testing a multi-media presentation of a health state description.** *Med Dec Making* 1994;14:336-44.
79. Boyle MH, Furlong W, Feeny D, Torrance GW, Hatcher J. **Reliability of the health utilities index - Mark III used in the 1991 cycle 6 Canadian General Social Survey Health Questionnaire.** *Qual Life Res* 1995;4:249-57.
80. Gold MR, Russell LB, Siegel JE. **Cost-effectiveness in health and medicine.** Oxford: Oxford University Press; 1996.
81. Froberg DG, Kane RL. **Methodology for measuring health-state preferences - III: Population and context effects.** *J Clin Epidemiol* 1989;42:585-92.
82. Christiansen F. **Diagnostic imaging of acute pulmonary embolism.** *Acta Rad Suppl* 1997;38(suppl 410):7-33.
83. Nease RF, Tsai R, Hynes LM, Littenberg B. **Automated utility assessment of global health.** *Qual Life Res* 1996;5:175-82.
84. Hennekens CH; Buring JE. **Epidemiology in medicine.** 1st ed. Little, Brown and Co.; 1987.
85. O'Sullivan EF. **Duration of anticoagulant therapy in venous thrombo-embolism.** *Med J Aust* 1972;2:1104-7.

86. Levine MN, Raskob G, Landefeld S, Hirsh J. Hemorrhagic complications of anticoagulant treatment. *Chest* 1995;108(4):276S-90S.
87. Mathiesen T, Benediktsdottir K, Johnsson H, Lindqvist M, von Holst H. Intracranial traumatic and non-traumatic haemorrhagic complications of warfarin treatment. *Acta Neurol Scand* 1995;91(3):208-14.
88. Reverter JC, Tassies D, Maragall S, Monteagudo J, Escolar G, Ordinas A. Accidentes hemorrágicos durante el tratamiento ambulatorio prolongado con acenocumarol. [Hemorrhagic accidents during prolonged ambulatory treatment with acenocumarol.] in Spanish. *Med Clin (Barc)* 1995;105(4):127-30.
89. Gullov AL, Koefoed BG, Petersen P. Blodningskomplikationer til peroral antikoagulansbehandling. *Nordisk Med* 1995;110(4):114-8.
90. Landefeld CS, Beyth RJ. Anticoagulant-related bleeding : clinical epidemiology, prediction and prevention. *Am J Med* 1993;95(3):315-28.
91. Palareti G, Leali N, Coccheri S, Poggi M, Manotti C, D'Angelo A, Pengo V, Erba N, Moia M, Ciavarella N, et al. Complicanze emorragiche della terapia anticoagulante orale: risultati dello studio prospettico multicentrico ISCOAT (Italian Study on Complications of Oral Anticoagulant Therapy). [Bleeding complications of oral anticoagulant treatment: an inception-cohort, prospective, collaborative Italian study]. *G Ital Cardiol* 1997;27(3):231-43.
92. Brandjes DPM, Buller HR, Heijboer H, Huisman MV, de Rijk M, Jagt H, ten Cate JW. Randomised trial of effect of compression stockings in patients with symptomatic proximal-vein thrombosis. *Lancet* 1997;349:759-62.
93. Miller DK, Homan SM. Determining transition probabilities: Confusion and suggestions. *Med Dec Making* 1994;14:52-8.
94. Gould MK, Dembitzer AD, Doyle RL, Hastie TJ, Garber AM. Low-molecular-weight Heparins compared with unfractionated heparin for treatment of acute deep venous thrombosis. A Meta-analysis of randomized, controlled trials. *Ann Intern Med* 1999;130:800-9.
95. Dilley A, Austin H, Hooper WC, Lally C, Ribeiro MJA, Wenger NK, Silva V, Rawlins P, Evatt B. Relation of three genetic traits to venous thrombosis in an African-American population. *Am J Epidemiol* 1998;147(1):30-5.
96. Critchfield GC, Willard KE. Probabilistic analysis of decision trees using Monte Carlo simulation. *Med Dec Making* 1986;6:85-92.

97. Naimark DM, Naglie G, Detsky AS. The meaning of life expectancy: what is a clinically significant gain? *J Gen Intern Med* 1994;9:702-7.
98. Krahn MD, Mahoney J, Eckman MH. Screening for prostate cancer: a decision analytic view. *JAMA* 1994;272:781-6.
99. Krahn MD, Detsky AS. Should Canada and the United States universally vaccinate infants against Hepatitis B? A cost-effectiveness analysis. *Med Decis Making* 1993;13:4-20.
100. Disch DL, Greenberg ML, Holzberger PT. Managing chronic atrial fibrillation: a Markov decision analysis comparing warfarin, quinidine, and low-dose amiodarone. *Ann Intern Med* 1994;120:449-57.