

INFORMATION TO USERS

This manuscript has been reproduced from the microfilm master. UMI films the text directly from the original or copy submitted. Thus, some thesis and dissertation copies are in typewriter face, while others may be from any type of computer printer.

The quality of this reproduction is dependent upon the quality of the copy submitted. Broken or indistinct print, colored or poor quality illustrations and photographs, print bleedthrough, substandard margins, and improper alignment can adversely affect reproduction.

In the unlikely event that the author did not send UMI a complete manuscript and there are missing pages, these will be noted. Also, if unauthorized copyright material had to be removed, a note will indicate the deletion.

Oversize materials (e.g., maps, drawings, charts) are reproduced by sectioning the original, beginning at the upper left-hand corner and continuing from left to right in equal sections with small overlaps. Each original is also photographed in one exposure and is included in reduced form at the back of the book.

Photographs included in the original manuscript have been reproduced xerographically in this copy. Higher quality 6" x 9" black and white photographic prints are available for any photographs or illustrations appearing in this copy for an additional charge. Contact UMI directly to order.

UMI

A Bell & Howell Information Company
300 North Zeeb Road, Ann Arbor MI 48106-1346 USA
313/761-4700 800/521-0600



Université d'Ottawa • University of Ottawa

Characterization of the murine Unp promoter

Michael Kilcup

Thesis submitted to the School of Graduate Studies and Research in partial
fulfillment of the requirements for the degree of
Master of Science

Department of Biochemistry
University of Ottawa
Ottawa, Ontario
CANADA

© Michael Kilcup, Canada, 1998



National Library
of Canada

Acquisitions and
Bibliographic Services

395 Wellington Street
Ottawa ON K1A 0N4
Canada

Bibliothèque nationale
du Canada

Acquisitions et
services bibliographiques

395, rue Wellington
Ottawa ON K1A 0N4
Canada

Your file Votre référence

Our file Notre référence

The author has granted a non-exclusive licence allowing the National Library of Canada to reproduce, loan, distribute or sell copies of this thesis in microform, paper or electronic formats.

The author retains ownership of the copyright in this thesis. Neither the thesis nor substantial extracts from it may be printed or otherwise reproduced without the author's permission.

L'auteur a accordé une licence non exclusive permettant à la Bibliothèque nationale du Canada de reproduire, prêter, distribuer ou vendre des copies de cette thèse sous la forme de microfiche/film, de reproduction sur papier ou sur format électronique.

L'auteur conserve la propriété du droit d'auteur qui protège cette thèse. Ni la thèse ni des extraits substantiels de celle-ci ne doivent être imprimés ou autrement reproduits sans son autorisation.

0-612-32539-3

Abstract

The ubiquitin-mediated proteolytic pathway is a field of intense interest due to the wide range of metabolic processes which are influenced by the covalent attachment of ubiquitin moieties to target proteins. In most, but not all cases, ubiquitination of a protein leads to its destruction by the 26S proteasome. Our lab is interested in the physiological role of the murine Unp proto-oncogene, a putative ubiquitin protease, which we postulate is involved in removing ubiquitin molecules from protein substrates, thereby preventing or delaying their degradation by the 26S proteasome. The work presented in this thesis describes the characterization of the Unp promoter and an analysis of Unp expression patterns in adult mice. Polymerase chain reaction (PCR)-mediated deletion mutagenesis was carried out using the full-length Unp promoter as a template and deletion constructs were designed by fusion of PCR products to the chloramphenicol acetyltransferase (CAT) reporter gene. Unp promoter deletions were subsequently transiently transfected into 293T human fibroblast cells and P19 murine embryonal carcinoma cells and promoter activity was assessed by CAT analysis. Transgenic mice were created that employed a 411 bp fragment of the Unp promoter driving expression of the *E. Coli* β -galactosidase reporter gene. Expression of the transgene was then assessed by Northern blot analysis as well as tissue sectioning and staining with 5-bromo-4-chloro-3-indolyl- β -D-galactopyranoside (X-GAL).

CAT analysis revealed significant differences in Unp promoter activity between distinct deletion clones, confirming the presence of both positive and negative regulatory elements within the promoter region. As well, the specific removal of a putative E2F-1

binding site diminished Unp promoter activity approximately two-fold, raising the possibility that the Unp promoter may be regulated by the E2F family of transcription factors.

Northern analysis of transgenic mice showed detectable transgene expression only in the testes of adult male mice. Inspection of X-GAL-treated testis sections revealed intense staining in round spermatids, potentially suggesting a role for the gene in spermatogenesis. Although the true in vivo function of Unp is unknown at this time, it is hoped that a gene targeting approach which will produce mice homozygous null for Unp enzyme will answer these important questions.

Dedication

I wish to dedicate this thesis to my mother for her neverending belief in me.

-iv-

After all you've seen, why can't you believe?

Fox Mulder

Acknowledgements

I am indebted to several individuals who made an effort to take an 'Easterner' under their wing and make me feel at home during my time as a member of the Cancer Research Group. I would especially like to thank my supervisor for the past two years, Dr. Douglas Gray, for taking such a chance on me by offering me a position in his lab despite my glaring lack of experience. His helpful insights and philosophical views on all things scientific and non-scientific were always a great source of inspiration.

I have made many friendships during my Master's degree and I would like to extend my gratitude to all those who have made my stay so rewarding. Space constraints being what they are, however, I am limited to mentioning the following individuals:

Alan, for his support in all my endeavours, no matter how ridiculous or self-absorbed they may have seemed. A great friend who is always willing to lend a helping hand or listen to petty problems.

Yvonne, for her excellent technical guidance and seemingly endless supply of patience with me. She has been instrumental in my training and I will never forget her kindness and generosity toward me. I have mostly enjoyed our often bizarre discussions covering the X-Files, Star Trek, The Simpsons...

Dave, for his always interesting take on a wide variety of issues. Our noon hour basketball sessions will always be remembered for their intensity (in spite of their one-sidedness).

Ninan, for providing an insightful and often contradictory commentary during

numerous debates and for sparking an interest for soccer inside me.

Mark. for helping me rediscover my passion for basketball and to not take things too seriously. His desire to beat me at one-on-one was always a great motivational tool.

Helen. for always providing a counterpoint to my opinions on various sports teams (i.e. New York Yankees, Oakland Raiders). Her hospitality toward me will always be remembered. May her husband Bill live to see the day that the Boston Red Sox win a World Series (not!).

Tina. for providing me with sound advice and for always being a great listener.

Dipika. for helping me to believe in myself and for making me a better person.

And, finally. special thanks to the members of the radiation biology group, whose presence in our lab greatly enhanced my social life and showed me that life is only what you are willing to make of it. I will never forget all the good times we have shared together.

Table of Contents

Abstract	-i-
Dedication	-iii-
Acknowledgements	-v-
List of Figures	-ix-
List of Abbreviations	-xi-
1. Introduction	-1-
1.1 The Ubiquitin-Proteasome Pathway	-1-
1.2 Deubiquitinating Enzymes	-6-
1.3 Ubiquitin carboxyl-terminal hydrolases (UCHs)	-7-
1.4 Ubiquitin-specific proteases (Ubps)	-8-
1.5 The murine Unp gene	-9-
1.6 Unp expression patterns and the Unp promoter	-10-
1.7 Unph expression in lung tumours	-12-
1.8 Regulation of eukaryotic gene expression	-13-
1.9 Transcriptional control of gene expression	-13-
1.10 Tissue-specific regulation of gene expression	-14-
1.11 E2F and the ubiquitin-proteasome pathway	-19-
2. Materials and Methods	-23-
2.1 Construction of promoter-chloramphenicol acetyltransferase (CAT) reporter plasmids	-23-
2.2 Construction of a Unp promoter-CAT reporter plasmid lacking a putative E2F binding site	-24-
2.3 Cell culture conditions	-25-
2.4 Transfection of reporter constructs	-25-
2.5 Harvesting of lysates from transfected cells for β -Galactosidase and CAT analysis	-26-
2.6 β -Galactosidase Analysis	-26-
2.7 CAT Analysis	-27-
2.8 Establishment of Unp-LacZ transgenic mice	-28-
2.9 Genomic DNA Isolation from mouse tails	-28-
2.10 Genotype analysis of transgenic mice	-29-
2.11 RNA Isolation and Northern Blot analysis from transgenic mice	-30-
2.12 Sectioning of tissues and X-Gal staining	-31-

3. Results	-33-
3.1 CAT assays	-33-
3.1.1 CAT analysis of Unp promoter deletions in lysates from 293T and P19 cells	-33-
3.1.2 Analysis of a Unp promoter construct mutant for a putative E2F-1 binding site	-40-
3.2 Analysis of Unp-LacZ transgenic mice	-42-
3.2.1 Genotyping of transgenic mice	-42-
3.2.2 Northern blot analysis of transgenic mice	-46-
3.2.3 Analysis of tissue sections from transgenic mice	-51-
4. Discussion	-56-
5. Conclusion	-62-
References	-64-

List of Figures

Figure 1: The ubiquitin-proteasome pathway	-3-
Figure 2: Mechanisms of cell-specific transcriptional activation	-16-
Figure 3: Mechanisms of transcriptional inhibition	-18-
Figure 4: CAT reporter constructs	-34-
Figure 5: CAT analysis of Unp promoter deletions in 293T cells	-36-
Figure 6: Quantification of the activity of Unp-CAT reporter minigene constructs in 293T cells	-37-
Figure 7: CAT analysis of Unp promoter deletions in P19 cells	-38-
Figure 8: Quantification of the activity of Unp-CAT reporter minigene constructs in P19 cells	-39-
Figure 9: Sequence of the Unp promoter	-41-
Figure 10: CAT analysis of a Unp promoter mutated for a potential E2F-1 binding site	-43-
Figure 11: Quantification of CAT activity for a Unp promoter mutated for a potential E2F-1 binding site	-44-
Figure 12: Schematic of the 3.8 kb Unp-LacZ transgene	-45-
Figure 13: Genotype of progeny derived from founder 3470♀	-47-
Figure 14: Genotype of progeny derived from founder 3587♂	-48-
Figure 15: Genotype of progeny derived from founder 3627♀	-49-
Figure 16: Genotype of progeny derived from founder 3630♂	-50-
Figure 17: Northern blot analysis of transgene expression in adult mouse tissues ...	-52-
Figure 18: Northern blot analysis of Unp expression in adult mouse tissues	-53-

Figure 19: X-GAL staining of testis sections from adult mice -54-

List of Abbreviations

bp	Base pair
β -gal	β -galactosidase
cDNA	Complementary DNA
CAT	Chloramphenicol acetyltransferase
Cys	Cysteine
DNA	Deoxyribonucleic acid
dNTP	Deoxyribonucleic triphosphate
Gly	Glycine
His	Histidine
hr	Hour
kb	Kilobase
LacZ	β -galactosidase
Lys	Lysine
min	Minute
mRNA	Messenger RNA
PBS	Phosphate buffered saline
PCR	Polymerase chain reaction
RNA	Ribonucleic acid
<i>S. cerevisiae</i>	<i>Saccharomyces cerevisiae</i>
SCLC	Small cell lung carcinoma

Ubp	Ubiquitin-specific protease
UCH	Ubiquitin-carboxyl terminal hydrolase
Unp	Ubiquitous nuclear protein
Unph	Human isoform of Unp
X-GAL	5-bromo-4-chloro-3-indolyl- β -D-galactopyranoside

1. Introduction

1.1 The Ubiquitin-Proteasome Pathway

Ubiquitin is a small (76-amino acids) peptide which is expressed in all eukaryotic cells. It is found in many cellular compartments, including the cytosol, the nucleus and the cell surface and is highly conserved across species lines, with only three amino acid differences between yeast and human sequences (35). Ubiquitin can be found either free or covalently attached to proteins within the cell. It is perhaps best known for tagging protein substrates for proteolytic degradation (33). Ubiquitination and subsequent degradation of a protein depends upon a series of enzymatic reactions. Briefly, the C-terminal Gly of ubiquitin is activated by ATP to a high-energy thiol ester in a reaction catalyzed by the ubiquitin-activating enzyme, E1. Following activation, ubiquitin is transferred from E1 to E2 (ubiquitin-conjugating enzyme) via transthioleation. Ubiquitin is then transferred either directly from E2 to a protein substrate (in which an isopeptide bond is formed between the activated C-terminal of ubiquitin and ϵ -amino groups of lysine residues within the substrate), or with the assistance of an E3 enzyme (ubiquitin-protein ligase). The absence or presence of E3 in the final conjugation step appears to have some dependence upon the nature of the substrate in question. Hence, it has been postulated that the presence of E3 provides an additional level of selectivity in substrate recognition (26).

Many stable mono-ubiquitin adducts can be found within the cell, including histones H2A and H2B (20) and the platelet-derived growth factor (PDGF) receptor (95). Mono-

ubiquitination appears sufficient in some cases for degradation of target proteins in vitro, such as α -globin in reticulocyte lysates (74). However, in many instances polyubiquitin 'chains' can form on the substrate which feature isopeptide linkages between Lys 48 residues of adjacent ubiquitin molecules. These chains are believed to be a signal for degradation of the protein by the 26S proteasome, a complex that is distributed throughout the cytoplasm and the nucleus. Multiubiquitin chains are recognized by a specific subunit of the 26S proteasome (S5a) and the substrate protein is degraded. These chains are then released from the complex and ubiquitin is recycled (Figure 1). While the enzymatic cascade involving E1, E2 and E3 is believed to be responsible for the majority of protein ubiquitination reactions, recent evidence has shown that in certain cases, the proteasomal degradation of the oncoproteins c-fos and c-jun may occur in a manner independent of the E1 enzyme of the ubiquitin cycle (32).

The mechanisms whereby substrates are recognized and become multiubiquitinated have not been fully elucidated at this time. It is known, for instance, that the ubiquitination complex can assemble ubiquitin chains directly on the protein substrate by repeated additions of ubiquitin units or by transferring preassembled polyubiquitin chains onto the targeted protein (7,82). However, what determines the stability of certain proteolytic substrates of the ubiquitination complex is a matter of some debate. The half-lives of artificial protein substrates show a strong dependence on the N-terminal residue of the protein, an effect commonly known as the 'N-end rule' (83) and evidence suggests the

Figure 1: The ubiquitin-proteasome pathway

Ubiquitin is transferred to a target protein (substrate) through a series of enzymatic reactions involving E1, E2 and E3 enzymes. The ubiquitinated protein is addressed to the 26S proteasome where it is degraded into small peptides and free ubiquitin chains are released by deubiquitinating enzymes.

E1: Ubiquitin-activating enzyme: E2: Ubiquitin-conjugating enzyme: E3: Ubiquitin-protein ligase: Doa4: yeast deubiquitinating enzyme: isoT: human isopeptidase T: 26S: proteasome: U: ubiquitin

Ubiquitin-mediated proteolysis

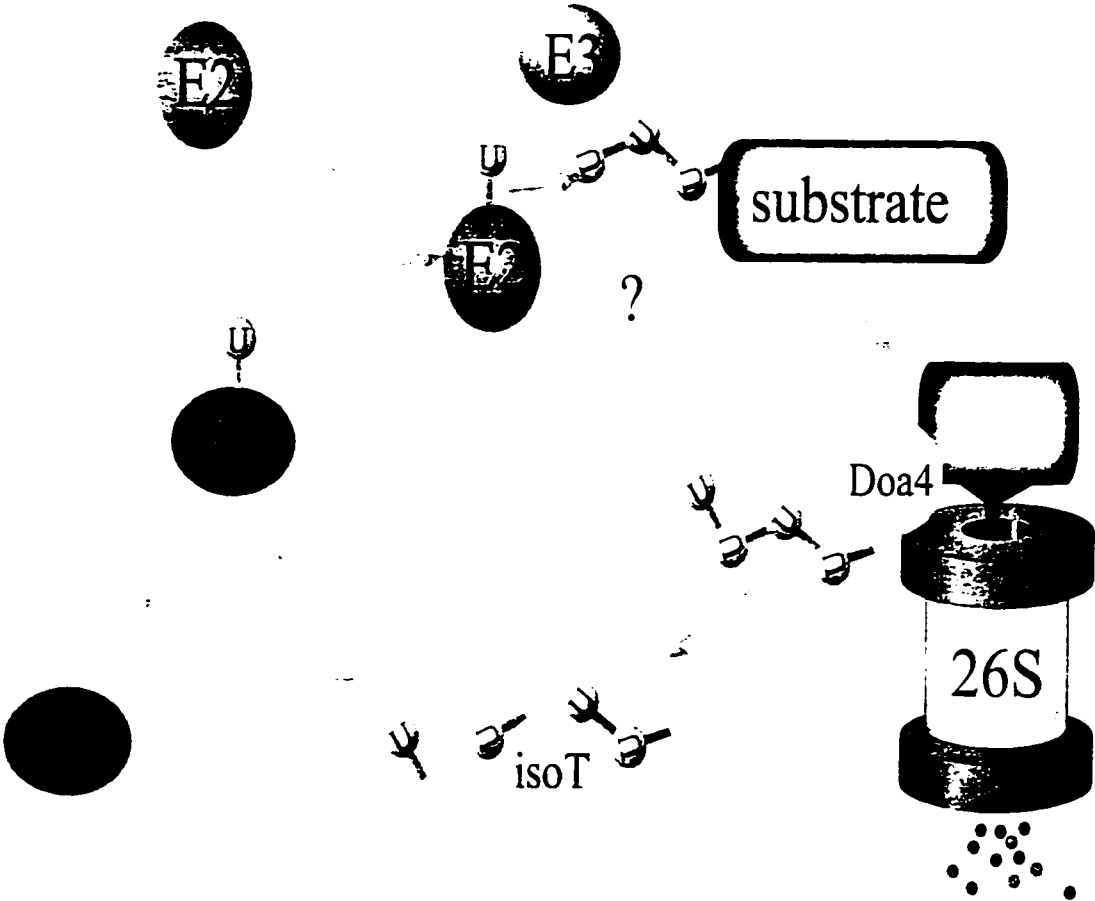

amino terminus is recognized by E3 (64). As well, several kinds of proteolytic recognition motifs have been recognized, including hydrophobic and amphipathic recognition sequence elements that are essential for binding of polyubiquitin chains to the S5a subunit of the 26S proteasome (3). A fuller understanding of substrate recognition by the ubiquitination complex will provide many clues as to why certain proteins are efficiently ubiquitinated and degraded and others are rarely, if ever, modified.

A wide variety of cellular processes are influenced by the ubiquitin-proteasome pathway. These include cell-cycle progression, programmed cell death, ribosomal assembly, antigen processing, viral pathogenesis, chromosome segregation and DNA replication just to name a few (27). The continual destruction of cell proteins may appear to be costly in terms of energy expenditure by the cell (although only a small fraction of cell proteins normally undergo rapid and continuous turnover), but it serves several important homeostatic functions. Selective proteolysis enables a protein to reach a steady-state level in a shorter period of time due to its shorter half-life. Additionally, regulated protein degradation eliminates any chance of those targeted proteins being reactivated inappropriately. Several lines of evidence support the theory that rapid elimination of rate-limiting enzymes and regulatory proteins is integral to the control of growth and metabolism. Of particular interest is the role of ubiquitin-mediated proteolysis in the timed destruction of key regulatory proteins in the eukaryotic cell cycle. Timed proteolysis is essential for regulating the activity of cyclin-dependent kinases (CDKs), the enzymes which promote the

progression of the cell cycle. This regulation is accomplished through degrading CDK activators and inhibitors, including mitotic cyclins (53) and p27 (58). A mounting body of evidence suggests ubiquitin also plays a significant etiological role in a variety of human diseases, including various forms of cancer. For instance, the human papillomavirus E6-AP protein, functioning as an E3 enzyme, contributes to oncogenic transformation of cervical cells by promoting the ubiquitination and degradation of the tumour suppressor p53 (72). As well, studies have shown increased ubiquitination and degradation of the putative tumour suppressor and CDK inhibitor, p27, in aggressive colorectal carcinomas (49). Similarly, ubiquitination plays a prominent role in various neurological disorders, including Huntington's disease (HD), which involves the association of the huntingtin protein with a ubiquitin-conjugating enzyme (E2) in patients symptomatic for the disorder (37). It is believed this association may affect the regulated catabolism of the huntingtin protein, which could significantly affect the progression of the disease. Recent findings on HD suggest the huntingtin protein forms misfolded, ubiquitinated inclusions within neuronal nuclei as a consequence of a CAG/polyglutamine repeat expansion (10, 73).

What is unknown at this time is whether alterations in ubiquitination play a causative role in the aforementioned diseases. There are, however, specific cases of defects in protein ubiquitination having a direct causative role in the etiology of human diseases. For instance, it is known that Angelman syndrome, which is characterized by mental retardation, seizures and abnormal gait, is caused by a mutation in the 5' end of the UBE3A gene, which functions

as a ubiquitin-protein ligase (39). This mutation is believed to disrupt the ligase activity of UBE3A, thereby preventing ubiquitination of its protein substrate. Additionally, a candidate tumour suppressor gene, TSG101, has been found to be frequently mutated in several human breast and prostate cancers (62, 77). The most prevalent TSG101 deletion in both breast and prostate cancers has been shown to disrupt the active site of a ubiquitin conjugating enzyme homologue contained within an amino-terminal domain, suggesting a role for TSG101 in protein ubiquitination (62).

A final example of the importance of protein ubiquitination is provided by the NF κ B signal transduction pathway. Studies have shown that the transcription factor NF κ B is activated by destruction of the inhibitory molecule, I κ B, by the ubiquitin-proteasome pathway (9). This effectively exposes the NF κ B nuclear localization signal and allows its translocation to the nucleus, permitting the cell to respond to various extracellular stimuli (i.e., mitogens, cytokines, viral proteins, etc.) and to elicit an immune response. Clearly, the role of protein ubiquitination in regulating intracellular protein turnover is of great significance to proper cell function and the maintenance of intracellular homeostasis.

1.2 Deubiquitinating Enzymes

Just as ubiquitin conjugation can directly affect the rate of proteolysis, reaction rates will also center on the frequency of deubiquitinating events. Polyubiquitin chains which assemble on target proteins are highly reversible, with rapid addition and removal of

ubiquitin from the substrate. Proteolytic processing at the ubiquitin C-terminus is catalyzed by a superfamily of enzymes collectively known as deubiquitinating enzymes. Such processing is believed to be required for recycling of monomeric ubiquitin from polyubiquitin chains, release of polyubiquitin chains from substrates prior to degradation by the 26S proteasome, reversal of regulatory ubiquitination, and editing of inappropriately ubiquitinated proteins, including removal of ubiquitin from small cellular nucleophiles like glutathione (27). These enzymes fall into two distinct classes: ubiquitin-specific proteases (Ubps) (2) and ubiquitin C-terminal hydrolases (UCHs) (60). Both classes of enzymes are capable of hydrolyzing the peptide bond at the C-terminus of ubiquitin and both contain highly divergent Cys and His residues which are essential for catalytic activity of the enzyme(s) (89).

1.3 Ubiquitin carboxyl-terminal hydrolases (UCHs)

The UCHs are relatively small (25-28 kDa) enzymes which are capable of cleaving peptide extensions up to 20 residues from ubiquitin with high efficiency and low sequence preference, but unlike the Ubps, cannot cleave larger extensions (87). Deletion of a yeast UCH shows no striking phenotypic abnormalities, suggesting an overlap of function between the UCHs and the Ubps (48). However, some UCHs display tissue-specific patterns of expression. For example, PGP9.5 is a neuronal UCH that accounts for roughly 2% of the total soluble protein in the mammalian brain (88) and is expressed exclusively in neurons

and neuroendocrine cells (90).

1.4 Ubiquitin-specific proteases (Ubps)

The Ubp enzymes (50-300 kDa) are larger than UCHs and are capable of cleaving ubiquitin from a wide range of protein substrates in vitro. It is therefore not surprising to find that a number of distinct Ubps have been cloned. In yeast alone there are 16 Ubps, which raises the possibility that specific protein turnover rates can be differentially regulated by these enzymes. Various functions assigned to Ubps include cleavage of ubiquitin from the remnants of degraded protein (59) and disassembly of polyubiquitin chains to yield functional monomers (1). They have also been shown to act in cell fate determination in *Drosophila* (29), transcriptional silencing in *S. cerevisiae* (51) and the cellular response to cytokines (96). Many yeast Ubp mutants do not display discernible phenotypes, suggesting that there may be considerable overlap in Ubp functions. For example, yeast which are mutant for the deubiquitinating enzyme Doa4 are viable but show an accumulation of small ubiquitinated species still bound to the 26S proteasome (59), suggesting that Doa4 functions late in the proteolytic pathway by cleaving ubiquitin from substrate remnants still bound to protease. Additionally, mutational analysis of the yeast Ubp14 enzyme (the yeast homolog of human isopeptidase T) suggests it plays a role in disassembling unanchored 'free' polyubiquitin chains. Yeast deficient for Ubp14 showed a striking accumulation of free ubiquitin chains and diminished levels of protein degradation (1). Given the abundance of

different Ubp enzymes in the cell, it would seem unlikely to find accumulation of ubiquitinated species in *doa4* or *ubp14* mutants. The fact that these species are prevalent may be due to high substrate specificity among the Ubps. Perhaps the most important finding to date concerning Ubps with regards to human disease involves the characterization of the human *tre-2* oncogene, which appears to be tumorigenic when present in an inactive form (59). The mutant form of the protein may act in a dominant-negative fashion, interfering with *tre-2* enzyme-mediated degradation of one or more regulators of cell proliferation. It is apparent that changing the rate of ubiquitin removal from a substrate will alter the likelihood of the multiubiquitinated intermediate being recognized by the 26S proteasome. Taken together, these data suggest deubiquitinating enzymes play an equally important role in regulating intracellular protein levels.

1.5 The murine Unp gene

The murine Unp gene was initially discovered during a survey of genes near the Mpv 20 retroviral insertion site (13). The gene spans 22 exons distributed over 47.4 kb, all of which has been sequenced (12). Analysis of the Unp cDNA revealed homology to the aforementioned human *tre-2* oncogene and consensus Cys and His domains which are essential for catalytic activity of DUB enzymes (12). Unp was initially classified as an oncogene due to its ability to induce tumor formation in nude mice injected with NIH 3T3 cells transfected with Unp (23). Subsequently, Unp was shown to possess ubiquitin protease

activity *in vitro* by virtue of its ability to cleave ubiquitin from ubiquitin- β -gal fusions (18). Surprisingly, Unp was also shown to efficiently cleave ubiquitin-proline- β -gal fusions *in vitro* (18). The ubiquitin-proline bond does not occur naturally and is poorly cleaved by presently studied Ubps (21). The fact that it is able to precisely cleave this type of linkage has led to the hypothesis that Unp possesses a more 'relaxed' active site conformation that allows it access to the sterically hindered ubiquitin-proline bond, where other Ubps fail (18). While the biological significance of this novel cleavage activity is currently under investigation, it is possible that Unp is capable of cleaving ubiquitin-like proteins from a wide range of substrates.

1.6 Unp expression patterns and the Unp promoter

Northern blot analysis revealed Unp mRNA levels to be comparable in all mouse tissues examined except testes, where the transcript is more abundant (23) and in embryonic stem cells, where expression is considerably lower (Gray, D.A., unpublished data). This data has led to the hypothesis that Unp is constitutively expressed in all tissues and that the gene plays a normal, 'housekeeping' role in order to maintain steady-state levels of regulatory proteins inside the cell. Support for the putative housekeeping function of Unp was obtained through an analysis of the Unp promoter. Di Fruscio et al. have demonstrated that a 1.1 kb genomic clone containing sequences 5' of the Unp transcriptional start site possesses promoter activity (12). Sequence analysis revealed the Unp promoter to be GC rich and

lacking both a TATA box and a CAAT motif upstream of the cap binding site, hallmarks of a 'housekeeping gene' promoter (42). Promoters which have a high density of the dinucleotide CpG are often found to be active in many tissues. Methylation of CpGs at the 5' ends of eukaryotic genes is believed to be an essential mechanism for repressing transcriptional levels, thereby permitting only basal expression in a wide variety of tissues (30). Although the possibility exists that Unp expression is influenced by methylation of CpGs within the Unp promoter, there is no direct evidence for this to date. Interestingly, the promoter was found to possess activity in either orientation (12), a property that is shared with other GC-rich promoters such as the phosphoglycerate kinase promoter (M. McBurney, personal communication) and the promoter that drives expression of both the Npat and ATM genes (31). The bidirectional activity of the Unp promoter is informative for two reasons: First, there is a core binding site for the 'initiator' (Inr) protein YY1 at positions -10 to -7 (CCAT) relative to the transcriptional start site of Unp. The YY1 protein can serve to direct the site of transcriptional initiation in promoters lacking a TATA element (75). However, in the reverse orientation the putative YY1 site in the Unp promoter is nonexistent, and promoter activity is readily detectable (12), implying that transcriptional initiation of Unp is positioned less precisely. Notwithstanding these arguments, recent primer extension experiments have shown that Unp possesses a single transcription start site (Gray, in press). Second, bidirectional promoter activity might also indicate that there are other actively transcribed genes upstream of Unp, indicating that this area of the murine genome is highly

active.

1.7 Unph expression in lung tumours

Characterization of the human homolog of Unp - Unph - revealed transcript levels were elevated in a subset of human lung tumours, namely adenocarcinomas and small cell carcinomas (SCLC), again reinforcing a role for the gene in cell transformation and tumorigenesis (22). The possibility exists, therefore, that Unp/Unph expression may be regulated in a tissue- or cell-type-specific fashion in various lung tumours. To support this possibility, there are numerous examples of genes involved in the ubiquitin-proteasome pathway displaying tissue-specific expression patterns. For instance, the human homolog of the yeast ubiquitin fusion degradation 1 protein (UFD1L) shows tissue-specific expression during embryogenesis in the eyes and in the linear ear primordia (61). Another group was able to show that the intracellular levels of ubiquitin mRNA were differentially regulated during sepsis in rat muscle (81). Upregulated expression of rat ubiquitin mRNA was detected in the fast-twitch extensor digitorum longus (EDL) muscle but not in the slow-twitch soleus muscle (81). Additionally, sepsis increased ubiquitin mRNA levels in the diaphragm but not in heart, liver, kidney or intestine (81). Alternatively, the normal expression patterns of Unp may be deregulated in lung tumours due to changes in the intracellular levels of positive and negative transcription factors. For example, it has been shown that members of the myc family of oncoproteins are overexpressed in small cell lung cancers (SCLC) (69).

Overexpression of c-myc has been linked in many cases to tumorigenesis, and is often correlated with aberrant expression of other known transcription factors, namely c-fos and c-jun (65, 92). It is possible that, under certain conditions (i.e., tumorigenesis), the expression of Unp is severely affected by deregulated expression of these or other transcription factors, and aberrant expression of Unp contributes to tumour formation by some as yet unknown mechanism.

1.8 Regulation of eukaryotic gene expression

In order to investigate the mechanism(s) that control Unp expression, it is necessary to understand that eukaryotic gene expression may be regulated at many levels. This may occur by deciding which genes are transcribed into RNA (transcriptional control), by controlling which of these RNA products are correctly spliced to produce a functional mRNA (RNA splicing). Gene regulation could also occur by deciding which of these fully spliced mRNAs are transported to the cytoplasm or by regulating which mRNAs are translated into protein (protein synthesis).

1.9 Transcriptional control of gene expression

In order for a gene to be transcribed it is necessary for proteins known as transcription factors to bind to specific regulatory regions of the gene to induce transcription by RNA polymerase. In most eukaryotic protein-coding genes these regulatory regions are

divided into four distinct elements: (a) The promoter, which in many genes contains the TATA box which is a binding site for the constitutively expressed transcription factor TFIID (70). (b) Upstream promoter elements (UPEs) which lie immediately upstream of the promoter itself. Many genes contain either or both the CCAAT box which binds a variety of different transcription factors, and a GC-rich sequence which binds the constitutively expressed transcription factor Sp1 (6). (c) Enhancer elements, which can be located at great distances either upstream or downstream from the promoter and oriented in either direction relative to the promoter. Although the enhancer cannot drive transcription itself, it can enhance the activity of the promoter by several orders of magnitude by binding several copies of various regulatory transcription factors (56). (d) Regulatory elements, which are often interdigitated with the UPEs and which bind transcription factors that only become active in specific cell types or in response to a particular signal. The presence of these sequences can confer a specific expression pattern on a gene (76).

1.10 Tissue-specific regulation of gene expression

The exact mechanism(s) responsible for the Unph overexpression phenotype in SCLC and adenocarcinomas is unknown at the present time. There are, however, several possibilities which might explain the upregulated expression of Unph mRNA in specific lung tumours. One scenario might involve elevated promoter activity in cells overexpressing Unph. In support of this theory, there are many genes which feature tissue or cell-specific

transcriptional activation through regulation of promoter activity (Figure 2). For instance, in some cases a transcription factor is synthesized in one cell type and is absent from all others (Figure 2A). Such is the case for the immunoglobulin (Ig) genes, which contain a binding site for Oct-2 (octamer transcription binding factor) (38). Oct-2 is synthesized only in B cells and hence only the Ig genes are activated, leading to antibody production in B cells. Similarly, genes expressed only in muscle cells such as creatine kinase contain binding sites for the transcription factor MyoD which is present only in muscle cells (57). Alternatively, a transcription factor which is expressed in an inactive form in most tissues only becomes activated in certain cell types (Figure 2B). For example, NF κ B is dissociated from its inhibitory protein, I κ B, in mature B cells and is free to translocate to the nucleus and promote the transcription of the immunoglobulin light chain (47). In addition to the dissociation of an inhibitory protein, transcription factors can also be activated by post-translational modifications such as phosphorylation (Figure 2C). Such is the case for the CREB factor which mediates the expression of genes in response to cyclic AMP (45). This process is dependent upon the ability of cAMP to stimulate the activity of protein kinase A which in turn phosphorylates CREB and converts it to an active form. Finally, transcription factors may be activated by binding a specific ligand which can induce a conformational change (Figure 2D). This occurs with the ACE1 factor in yeast, which, upon binding copper ions, is converted to an active form and is capable of inducing ACE1-dependent genes in response to copper (16). Therefore, the action of transcription factors on gene expression can

Figure 2: Mechanisms of cell-specific transcriptional activation

Activation of transcription factors by new synthesis (A), dissociation of an inhibitory protein (B), protein modification (C) or ligand binding (D).

be controlled not only by regulating their synthesis but also by regulating their activity.

Just as transcription of specific genes can be activated by the action of constitutively expressed or regulated transcription factors, it is also possible for transcription to be specifically inhibited by the action of a transcription factor (Figure 3). For example, the glucocorticoid receptor (GR) activates steroid-responsive genes by binding to a specific site in DNA, but can also repress other genes by binding to a distinct but related site (67). This effectively prevents another positively acting factor from binding to this site, thereby repressing transcription (Figure 3A). Similarly, the GR can also inhibit genes to which it cannot bind by complexing with the transcription factor AP1 in solution, once again inhibiting transcription (44) (Figure 3B). Alternatively, cases are known where inhibition occurs when a factor binds to another, DNA-bound, factor and prevents it activating transcription by masking its activation domain (Figure 3C). For instance, the yeast GAL4 protein binds to DNA before exposure to galactose but can only activate transcription following the galactose-induced dissociation of the inhibitory GAL80 protein which exposes the GAL4 activation domain (5). Finally, transcriptional repression might occur by direct binding of the repressor element to the DNA (Figure 3D). For example, the Nabl repressor protein, which inhibits transcription mediated by members of the NGF1-A family of immediate-early gene transcription factors, has been shown to act by a direct DNA-binding mechanism (79). This repressive ability is believed to be result from tight association of Nabl with the promoters of genes within the NGF1-A family.

Figure 3: Mechanisms of transcriptional inhibition

Transcription factors can inhibit transcription through a variety of mechanisms, including: (A) Binding to DNA and preventing a positively acting factor from binding; (B) interacting with the activator in solution and preventing it from binding; (C) binding to DNA with the activator and preventing it from activating transcription; (D) direct repression.

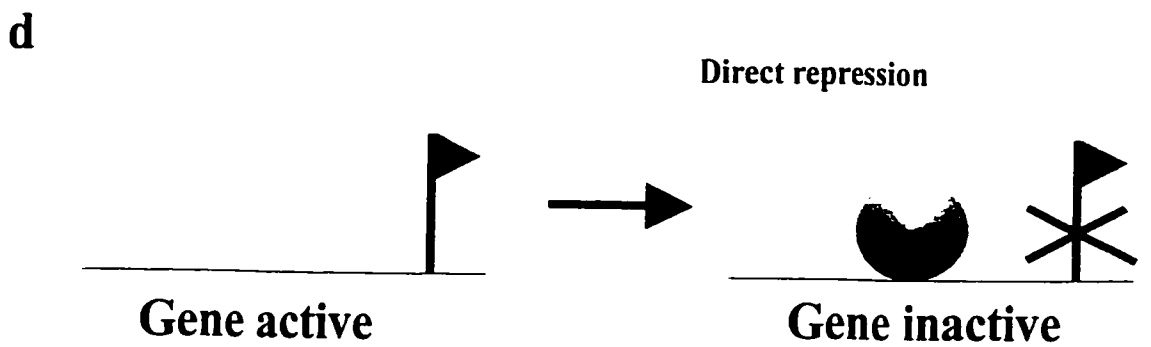
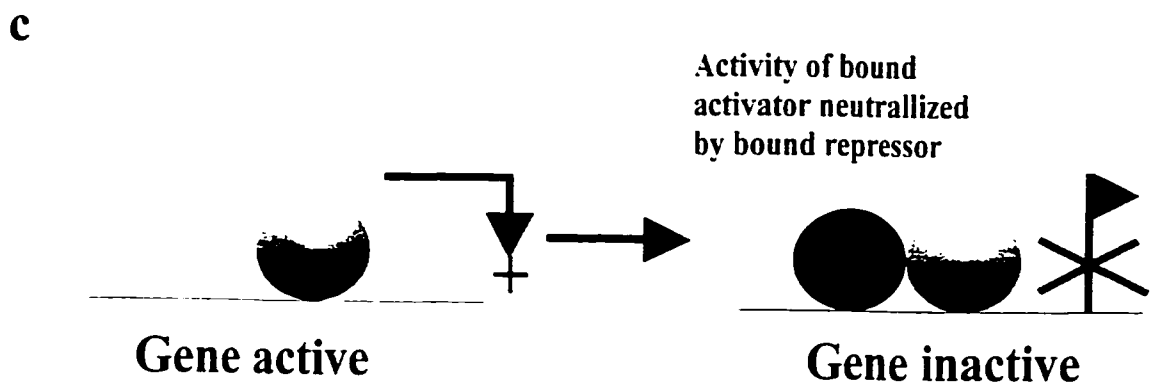
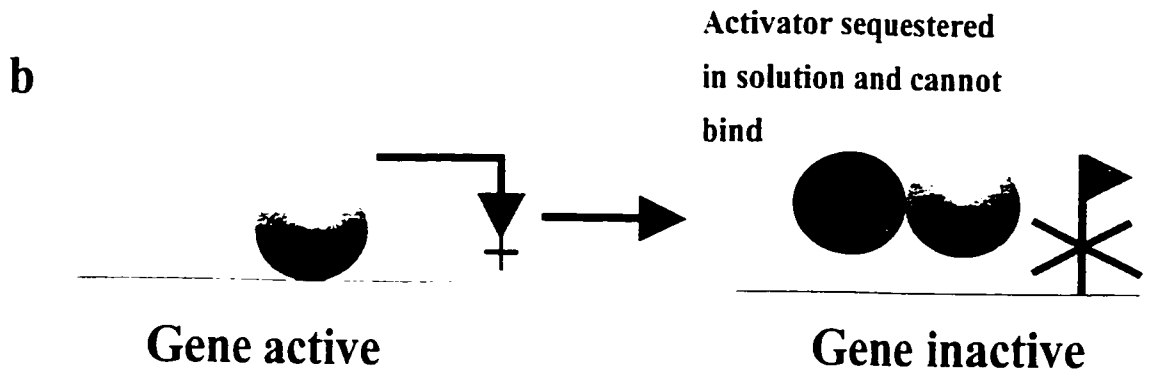
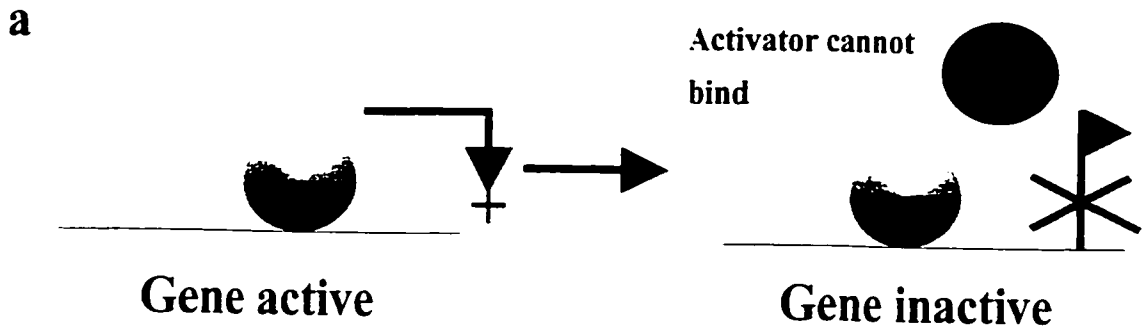

Other mechanisms which might explain the tissue-specific upregulation of Unph mRNA include alterations in either mRNA stability and/or chromatin conformation. Briefly, eukaryotic gene expression can be regulated at the post-transcriptional level by regulating the stability of mature transcripts in the cytoplasm. For example, the regulation of insulin growth factor 1 (IGF-1) gene transcription as well as the regulation of IGF-1 mRNA stability is tissue-specific during osteoblast differentiation (11). An additional level of gene regulation in eukaryotes occurs in the form of chromatin conformation. In differentiated cells there is evidence that chromatin containing genes that are never expressed in that particular cell type is in a different physical state from that containing genes which are actively transcribed (15). It has been postulated that DNA methylation plays a role in regulating chromatin condensation (30).

1.11 E2F and the ubiquitin-proteasome pathway

The Unp promoter contains many potential binding sites for the transcription factors AP1, AP2 and Sp1 (12). Of particular interest is the presence of a putative E2F-1 binding element in the promoter. The E2F family of transcription factors control the expression of a variety of genes with important cell-cycle regulatory functions, including c-myc, cyclin A, E2F-1, dihydrofolate reductase, DNA polymerase α , p107 and thymidine kinase (14). E2F transcription factors are heterodimers that consist of one of five related E2F polypeptides bound to one of two possible partners: DP-1 or DP-2 (4).

E2F-1 was originally classified as an oncogene because when co-expressed with other known oncogenes it leads to cellular transformation (93). However, mice homozygous for a nonfunctional E2F-1 allele develop a broad spectrum of tumours, suggesting E2F-1 possesses anti-tumour activity (94). The seemingly paradoxical roles of both oncogene and tumour suppressor gene imply that E2F-1 plays a critical role in the regulation of cellular proliferation. Support for this hypothesis is shown by the finding that cells held in quiescence by serum starvation can be driven all the way through G_1 into S by ectopic expression of E2F-1 alone (36).

Control of E2F-1 activity is tightly regulated within the mammalian cell cycle. In early G_1 , E2F-1 is tightly bound to the hypophosphorylated form of the retinoblastoma gene, pRb, effectively suppressing the trans-activation potential of E2F-1 and converting E2F-1 sites from positive to negative elements (84, 85). However, in late G_1 , CDKs phosphorylate pRb, dissociating the pRb/E2F-1 complexes and allowing the E2F-1/DP-1 complexes to reach their full trans-activation potential (84, 85). Viral oncogenes have been shown to exploit the trans-activation capabilities of E2F-1 by disrupting E2F-1/pRb complexes through direct interaction (i.e., adenovirus E1A), thereby promoting cellular proliferation and, ultimately, tumorigenesis (86).

Another level of E2F-1 regulation is accomplished through its own cell cycle-dependent expression. E2F-1 expression is undetectable in quiescent cells but rises as cells exit G_0 and approach mid- to late G_1 (19). E2F-1, and potentially other E2F family members,

can trans-activate the E2F-1 promoter during exit from G_0 , possibly contributing to the observed increase in E2F-1 synthesis (55). Transcription of the E2F-1 gene decreases in late G_1 , which depends at least in part on direct interaction of cyclin A with the extreme N-terminal region of E2F-1 (43). Especially intriguing was the discovery that E2F-1 is specifically targeted and degraded by the ubiquitin-proteasome pathway and that binding to pRb protects E2F-1 from untimely destruction (25,28). Therefore, in addition to transforming E2F-1 into a repressor, pRb also prevents E2F-1 catabolism during a period when pRb/E2F-1 complexes are crucial for proper cell cycle regulation. Somewhat surprising was the finding that adenovirus transforming proteins, such as E1A, also inhibit breakdown of E2F-1, despite E1A's ability to release E2F-1/pRb complexes (25). Additional support for a link between E1A and the ubiquitin-proteasome pathway was found when it was determined that E1A can interact with a member of the ubiquitin-conjugating family of enzymes, named mUBC9 (24). Because the stability of the E2F-1 transcription factor is largely dependent upon the ubiquitin-proteasome pathway, it is possible that E2F-1 trans-activation or repression of genes involved in the regulation of ubiquitin-mediated proteolysis (i.e., Unp) could conceivably initiate a feedback loop. If this were true, then under certain conditions (i.e., tumorigenesis), an perturbation of either E2F-1 or Unp expression could significantly alter the expression of the other, possibly leading to an alteration in the levels of other growth regulatory factors. The effect of E2F-1 binding to the Unp promoter and its effect upon promoter activity will be investigated in this thesis.

Unph is 90% and 85% identical to Unp at the protein and nucleotide level respectively, so it is likely that both the murine and human isoforms will have similar functions (22). It is possible that overexpression of Unph significantly alters the levels of substrate(s) that are degraded by the ubiquitin-proteasome pathway. In an effort to determine the in vivo substrate of Unp/Unph, mice which are homozygous null for Unp are presently being generated. It is hoped that a detailed analysis of mice which are deficient for Unp enzyme will provide vital clues as to what Unp's normal function in regulating intracellular protein turnover may be. Perhaps an alteration of growth regulatory protein levels by excess ubiquitin protease is sufficient to deregulate the normal cell cycle.

The central focus of the work presented in this thesis is to determine if Unp expression patterns are regulated, at least in part, by regulation of Unp promoter activity through analysis of: (a) Unp promoter activity in two distinct cell lines; (b) mutation of putative transcription factor binding sites and determining how they affect promoter activity (i.e., E2F-1); (c) developmental regulation of Unp expression in transgenic mice which feature the Unp promoter driving expression of a reporter gene, β -galactosidase.

2. Materials and Methods

2.1 Construction of promoter-chloramphenicol acetyltransferase (CAT) reporter plasmids :

Unp promoter-CAT minigene constructs were constructed by cloning PCR products into the vector pCAT (Promega). All PCR procedures used a plasmid (pDG 75) containing the full-length 1.1 kb murine Unp promoter as template DNA. PCR amplification was carried out on 50 μ l reaction mixtures containing 2 μ l template DNA (50 ng/ μ l), 2 μ l sense oligonucleotide primer (5 pmol/ μ l), 2 μ l antisense oligonucleotide primer (5 pmol/ μ l), 10 μ l dNTPs (1.25 mM), 1 μ l Vent (exo-) polymerase (2 U/ μ l, New England Biotechnologies), 5 μ l 10X buffer, and 28 μ l dd H₂O. Reaction conditions were as follows: 4 min at 94°C, 2 min at 80°C, 30 cycles of: (30 sec at 94°C, 30 sec at 58°C and 1 min at 72°C), and 10 min at 72°C. Sense oligonucleotide primers were: delete 1 (5'-aaaaactgcagacctctgtcggcttcggt-3'), delete 2 (5'-aaaaactgcaggcaggtgtggtgatgtatgc-3'), delete 3 (5'-aaaaactgcagacagctccaggacagcagc-3'), delete 4 (5'-aaaaactgcagaccagttgtcaccacg-3'), delete 6 (5'-aaaaactgcagcctcctgcacggatttagc-3'), delete 7 (5'-aaaaactgcagagtcagatcgcaggagcc-3') and delete 8 (5'-aaaaactgcaggtaacagcgcgtgggg-3'). All PCR reactions used a universal antisense primer, delete 9 (5'-aaaaactgcaggcgcacggcgtgctatggg-3'). PCR products were electrophoresed on 1% agarose gels and visualized by ethidium bromide staining. Products were then digested with PstI and ligated at 16°C overnight into the Pst I site of the pCAT vector using standard protocols (71). Clones were obtained having both orientations, as verified by

restriction digest with Sal I and sequence analysis by the ABI Prism 377 DNA Sequencer (Perkin Elmer) using the sense primers listed above and an antisense primer that hybridizes to the CAT reporter gene. oligo102 (5'-caactgactgaaatgcc-3').

2.2 Construction of a Unp promoter-CAT reporter plasmid lacking a putative E2F binding site

A minigene construct containing a Unp promoter mutant for a putative E2F binding site which drives expression of the CAT reporter gene was constructed using the Boehringer Mannheim Expand™ Long Template System. PCR procedures used a Unp promoter-CAT reporter plasmid (-868CAT) as template DNA. PCR amplification was carried out on 50 µl reaction mixtures containing 1 µl template DNA (10ng/µl), 3 µl sense primer (5 pmol/µl), (5'-aaactcgagacgcgtgccacagtgtctgtg-3'), 3 µl antisense primer (5 pmol/µl), (5'-aaactcgagcaggcacacaatagtgaaattg-3'), 7 µl dNTPs (1.25 mM), 1 µl enzyme mix (Boehringer-Mannheim), 5 µl 10X buffer, and 30 µl dd H₂O. Reaction conditions were: 2 min at 94°C, 10 cycles of: (10 sec at 94°C, 20 sec at 63°C and 9.5 min at 68°C), 20 cycles of: (10 sec at 94°C, 20 sec at 63°C, and 9.5 min at 68°C + 20 sec/cycle), and 10 min at 68°C. PCR products were electrophoresed on 1% agarose gels and visualized by ethidium bromide staining. Products were treated with proteinase K (5mg/ml) for 20 min at 37°C to remove any residual polymerase, extracted with phenol-chloroform (1:1), ethanol precipitated and resuspended in TE. Samples were then digested with Xho I, ethanol precipitated,

resuspended in TE and spun through a Sephadex™ G50 column. Products were ligated at 16°C overnight using standard protocols (71). Clones containing a unique Xho I site were verified by restriction digest and sequence analysis using the sense primer, delete 1, and the antisense primer, oligo 102. The resulting E2F-1 deletion construct was designated -868ΔCAT.

2.3 Cell culture conditions

293T and P19 cell cultures were maintained in α -MEM (minimal essential media) supplemented with 10% serum containing 7.5 % newborn serum and 2.5 % fetal bovine serum.

2.4 Transfection of reporter constructs

Putative promoter plasmids and controls were transiently transfected into 293T human fibroblasts and P19 embryonal carcinoma cells. Transfections were carried out in 60mm tissue culture dishes with approximately 1×10^6 293T cells/dish and approximately 5×10^5 P19 cells/dish. Cotransfections of 2 μ g of reporter plasmid and 2 μ g of the plasmid pDM2, in which the phosphoglycerate kinase promoter drives expression of *E. Coli* β -galactosidase, were accomplished using LipofectAmine (Gibco). Transfections were carried out for 6 hrs in a total of 3 ml of serum-free media at which point 2 ml of media containing 2X P19 serum was added to dishes and cells were left to grow overnight.

2.5 Harvesting of lysates from transfected cells for β -Galactosidase and CAT analysis.

Cells were harvested 24 hours after starting transfections. Dishes were washed twice with PBS (0.1 M), trypsinized and inactivated with serum-containing media. Cells were transferred to microcentrifuge tubes and pelleted for 5 min at 3000 rpm (4°C). Pellets were washed twice in 100 μ l PBS (0.1 M) pH 7.2 containing neither calcium nor magnesium (65) and centrifuged twice for 5 min at 3000 rpm (4°C). Pellets were then resuspended in 100 μ l 0.25 M tris-HCl pH 7.5 and subjected to three cycles of freeze-thaw (dry ice/ethanol bath followed by 37°C waterbath). Cell debris was removed by centrifuging at 14000 rpm for 15 min (4°C) and supernatants were collected for β -Galactosidase assays. Approximately half the sample was set aside and heat inactivated for 10 min at 65°C then centrifuged at 14000 rpm (4°C) for 15 min. Supernatants were then collected for CAT analysis. Protein concentrations for lysates intended for β -galactosidase and CAT analysis were assessed using a Bio-Rad Micro Protein assay.

2.6 β -Galactosidase Analysis

β -galactosidase activity of lysates from transiently transfected 293T and P19 cells were assessed by taking 100 μ g of lysate from either 293 T or P19 cells and resuspending in dd H₂O to a total volume of 400 μ l. To this, 400 μ l of 2X assay buffer (20 μ M NaPO₄ pH 7, 0.2 μ M MgSO₄, 20 μ M β -mercaptoethanol) and 200 μ l of substrate ONPG (o-nitrophenyl

β -D-galactopyranoside, BDH, 4mg/ml in 10 mM NaPO₄ pH 7) were added together in a 1 ml polystyrene cuvette. Activity was monitored using a Beckman DU 640 spectrophotometer at a wavelength of 420.0 nm with the manufacturer's kinetics program. The net change in absorbance per minute (dA/min) over a total time interval of 45 min was assumed to be directly proportional to the β -galactosidase activity of the sample. β -galactosidase activity was previously shown to be linear over 45 min. This value is reflective of the relative transfection efficiency of each individual sample and was used to optimize the quantity of sample used for the CAT assay.

2.7 CAT Analysis

CAT analysis was performed using a Molecular Probes FAST CAT™ Green (deoxy) chloramphenicol acetyltransferase assay kit. CAT activity of lysates from transiently transfected 293T and P19 cells were assessed via the following procedure: a sample (the quantity is determined from the β -galactosidase value for the sample) was resuspended in dd H₂O to a total volume of 30 μ l. To this, 5 μ l of FAST CAT Green substrate (Molecular Probes) were added and placed at 37°C for 5 min. Then, 5 μ l of acetyl coenzyme A (9mM) were added and the sample was placed at 37°C for 1 hr. Subsequently, 160 μ l of ice-cold ethyl acetate were added to stop the reaction and the sample was extracted. The product was then spotted (5 X 1 μ l) on a TLC (thin layer chromatography) sheet (aluminum, 20 X 20 cm, silica gel 60, EM™ Separations) and developed for approximately 15 min in a TLC tank

containing 200 ml of a chloroform/methanol mixture (170 ml chloroform + 30 ml methanol). The TLC plates were analyzed on a Storm fluorimager (Molecular Dynamics) using ImageQuant software.

2.8 Establishment of Unp-LacZ transgenic mice

Transgenic mice expressing the β -galactosidase (Lac Z) reporter gene under control of the Unp promoter were created to study the in vivo expression pattern of Unp. Blastocyst microinjections were performed using a 3.8 kb Hind III/Kpn I fragment that contained a 411 base pair Unp promoter fragment (derived from -411CAT) driving expression of Lac Z. The 411 bp promoter fragment was excised from -411CAT by Pst I digestion and ligated into the Pst I site of the SDK LacZ vector (a generous gift from Dr. M.W. McBurney) at 16°C overnight using standard protocols (71).

2.9 Genomic DNA Isolation from mouse tails

Genomic DNA was isolated from mouse tails via the following protocol: tail clippings were digested overnight at 37°C in microcentrifuge tubes in 400 μ l DNA extraction buffer (75 mM NaCl, 25mM EDTA, 10 mM tris-HCl pH 7.6, 1% SDS) containing 400 μ g/ml proteinase K. Subsequently, 112 μ l of a saturated NaCl (approximately 6M) solution were added to the warm DNA solution and vortexed immediately on high for 15 sec. Samples were then centrifuged for 10 min at 3000 rpm (4°C) and the supernatant was

transferred to a fresh tube. An equal volume of isopropanol was added to precipitate the DNA and the sample was centrifuged for 5 min at 14000 rpm (4°C). Pellets were washed with 70% ethanol, allowed to air dry and dissolved in 300 µl TE at 4°C overnight.

2.10 Genotype analysis of transgenic mice

Genomic DNA from mouse tails was digested overnight at 37°C using the following conditions: 60 µl of genomic DNA sample, 3.5 µl Bam HI (70 units), 10 µl 10X digestion buffer, 1 µl BSA (10mg/ml), and 25.5 µl dd H₂O. Samples were then precipitated with 2.5 volumes 95% ethanol and 0.1 volumes 3M sodium acetate, resuspended in 20 µl TE and electrophoresed on 0.8% agarose gels overnight at 25 V. DNA was then transferred to Hybond-N membranes (Amersham) overnight and UV cross-linked using the GS Gene Linker (Bio-Rad) at a setting of 125 mJ. Membranes were prehybridized for at least two hours at 42°C in a hybridization solution containing 50% de-ionized formamide, 5X SSC (standard sodium citrate), 1% SDS, 0.1 mg/ml sheared herring sperm DNA and 5X Denhardt's solution. Hybridization was carried out using a ³²P-labelled LacZ probe and labelling was accomplished using the Random Primed Labelling Kit (Boehringer-Mannheim). Hybridization was carried out at 42°C for 18-24 hours. Membranes were washed in 2 X SSC at room temperature and in 0.1 X SSC, 0.1% SDS at 65°C for 1 hour, then analyzed using the PhosphorImager SI system (Molecular Dynamics).

2.11 RNA Isolation and Northern Blot analysis from transgenic mice

Tissues were isolated from transgenic and non-transgenic mice by dissection and total RNA was prepared via the following procedure: the entire organ was placed in 2.5 ml of a cold 6M urea/3M LiCl (lithium chloride) solution. Tissues were homogenized with a polytron blender (Kinematica) at a setting of 7 until the solution appeared foamy. The samples were left on ice at 4°C overnight to precipitate RNA. Samples were then centrifuged at 10K for 30 min at 0°C at which point the supernatant was poured off and the pellet was resuspended in 2.5 ml cold 6M urea/3M LiCl solution. The sample was centrifuged again at 10K for 30 min. the supernatant was removed and the pellet was resuspended in 2 ml of a solution containing 10 mM tris-HCl pH 7.5, 0.5 % SDS and 50 µg/ml proteinase K then incubated for 20 min at 37°C. Samples were then extracted twice with phenol-chloroform (1:1). To precipitate RNA, sodium chloride solution was added to a final concentration of 0.1 M along with 2.5 volumes of 95% ethanol then placed at -20°C overnight. Subsequently, samples were centrifuged for 30 min at 10K and pellets were resuspended in 200 µl DEPC-(diethylpyrocarbonate) treated dd H₂O. RNA concentration was determined using a Beckman DU 640 spectrophotometer at a wavelength of 260 nm. (1 OD₂₆₀ = 40 µg RNA). Samples containing 20 µg total RNA. MOPS (3-[N-Morphorpholino]propane-sulfonic acid) pH 6.8, formaldehyde, formamide, RNA dye and ethidium bromide were electrophoresed on 1% agarose gels containing 2.2 M formaldehyde, 20 mM MOPS, 1 mM EDTA, and 5 mM sodium acetate at 35 V overnight. Electrophoresed RNA was transferred to Hybond-N

membrane (Amersham) overnight, and UV cross-linked using the GS Gene Linker (Bio-Rad) at a setting of 125 mJ. Membranes were prehybridized for at least 2 hours at 42 °C in a hybridization solution containing 50% de-ionized formamide, 5 X SSC, 1% SDS, 0.1mg/ml sheared herring sperm DNA and 5 X Denhardt's solution. Hybridization was carried out with a ³²P-labelled LacZ probe and labelling was accomplished using the Random Primed Labelling Kit (Boehringer-Mannheim). Hybridization was carried out at 42°C for 18-24 hours. The same membrane was stripped in boiling distilled water for 15 minutes and rehybridized with a fragment containing the full-length (3.7 kb) Unp cDNA (also known as T4). Membranes were washed in 2 X SSC at room temperature and in 0.5 X SSC, 0.1% SDS at 50°C for 30 min then analyzed using the PhosphorImager SI system (Molecular Dynamics). The positions of 18S and 28S rRNA were determined by ethidium bromide staining.

2.12 Sectioning of tissues and X-Gal staining

Freshly dissected tissues from transgenic and non-transgenic mice were placed in Lana's fixative (pH 7.1) containing 4.5 % paraformaldehyde, 0.25 M NaPO₄, and 14 % picric acid for 1 hour at 4°C. The fixative was then poured off and the tissues were perfused in a 10 % sucrose/0.1 M PBS solution containing sodium azide overnight at 4°C. Tissues were sectioned using a Microm HM 500 OM microtome and stained overnight at 37°C with X-Gal (8 mM potassium ferrocyanide, 8 mM potassium ferricyanide, 100 mM PBS pH 7.4.

-32-

1 mM MgSO₄, and 1mg/ml 5-bromo-4-chloro-3-indolyl-β-D-galactopyranoside), then mounted on glass coverslips. Slides were examined with a Zeiss Axiophot fluorescence microscope and visualized using Intellicam software.

3. Results

3.1 CAT assays

3.1.1 CAT analysis of Unp promoter deletions in lysates from 293T and P19 cells

PCR fragments were generated using the full-length 1.1 kb Eco RI/Sac I genomic fragment previously described (12) as template DNA and subcloned into the Pst I site of the promoterless pCAT reporter plasmid (Promega). All constructs were sequenced with an ABI Prism 377 automated sequencer to verify the absence of PCR-generated mutations. Promoter deletions were designed with a common 3' terminus such that the CAT reporter gene is under the control of progressively smaller fragments of the Unp promoter (see Figure 4 and refer to Materials and Methods). The Unp promoter deletions were subsequently transfected into both the 293T (human embryonal kidney) and P19 (murine embryonal carcinoma) cell lines. The rationale for choosing these cell lines are as follows: (a) previous studies examining Unp promoter function had been performed using 293T cells (12); (b) species differences between the two cell lines was not a concern based on results from prior experiments examining Unp and Unph expression patterns (Gray, D.A., unpublished; see also Discussion for more detail). Since Unph expression had been shown to be substantially elevated in adenocarcinomas of the lung as well as small cell lung carcinomas (22), we were interested in investigating the possibility that alterations in Unp/Unph expression in lung tumours could partly be a result of cell or tissue-specific promoter function.

Previous work examining Unp promoter function had shown the existence of a

Figure 4: CAT reporter constructs

CAT reporter minigene constructs were prepared by PCR such that the CAT gene is under control of progressively shorter fragments of the Unp promoter. The nucleotide representing the 5' end of the Unp DNA indicated for each construct represents the position of truncation relative to the transcriptional start site and differs for each individual minigene. All constructs feature a common 3' end, which contains the first 8 bases of the Unp cDNA. The full-length 1.1 kb Eco RI/Sst I genomic fragment (pDG 75) which served as the template DNA for all PCR reactions is indicated at the top of the figure. The arrows in each minigene construct indicate the direction of transcription. +1 is used to indicate the position of transcriptional initiation for the Unp gene. -411CAT was constructed by M. DiFruscio (12). The name of each deletion reflects the relative position of its 5' end respective to the site of transcriptional initiation (i.e. -868CAT).

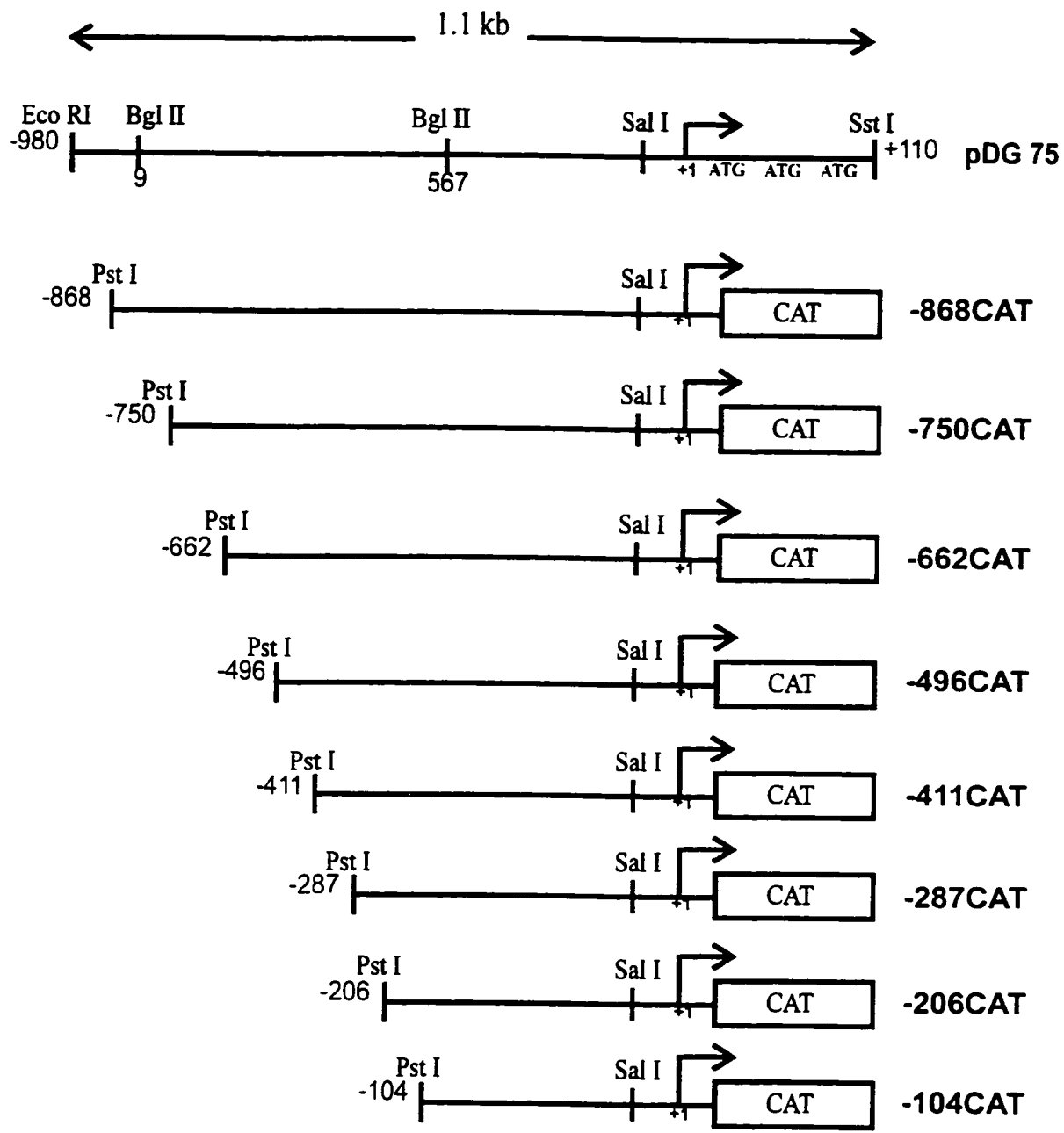

putative repressor element contained within a Bgl II fragment in the upstream region of the promoter (12) (Figure 4). When this region is deleted from the promoter, the resulting construct displayed between two and eight fold higher CAT activity than the full-length promoter (12). We were interested in the possible existence of other regulatory regions in the Unp promoter that may have an effect on CAT activity. Results show that particular Unp promoter deletions display different relative levels of CAT activity in different cell types (Figures 5-8). Because the relative transfection efficiencies were not comparable between 293T cells and P19 cells, a direct comparison of CAT activities for the promoter deletions between cell types was not possible. However, examination of the data does show distinct differences between CAT activities for the individual promoter deletions. For instance, the construct with the highest CAT activity in 293T cells was -104CAT while the construct with the lowest promoter activity was -206CAT (Figures 5.6). Conversely, the construct with the highest CAT activity in P19 cells was -411CAT while the construct with the lowest promoter activity was -868CAT. (Figures 7.8). These data suggest there may be regulatory regions within the Unp promoter which are cell-specific and have differing effects on promoter activity in different cell types. There were other results that were also of particular interest to us here. First, construct -104CAT displayed relatively high levels of CAT activity in both 293T and P19 cells (approximately 13% and 8% acetylation in 293T cells and P19 cells respectively), supporting the presence of a positive regulatory domain in this region of the promoter (Figures 5-8). This data also positions the minimal promoter for the Unp gene

Figure 5: CAT analysis of Unp promoter deletions in 293T cells

Activities of the CAT minigene constructs were determined by transient transfection into cultures of the 293T cell line followed by measurement of CAT activity in cellular extracts. The activities shown are representative of results obtained from three independent sets of transfections (n=3). Numbers above each lane indicate the identity of the deletion construct used for each transfection. The positive control for CAT activity is pgkCAT, in which the phosphoglycerate kinase promoter drives expression of the CAT gene. The negative controls are the promoterless vector, pCAT, and a mock transfection containing no DNA. 10^{-3} and 10^{-4} refer to dilutions of a reference standard for acetylated products (provided by Molecular Probes).

293T Cells

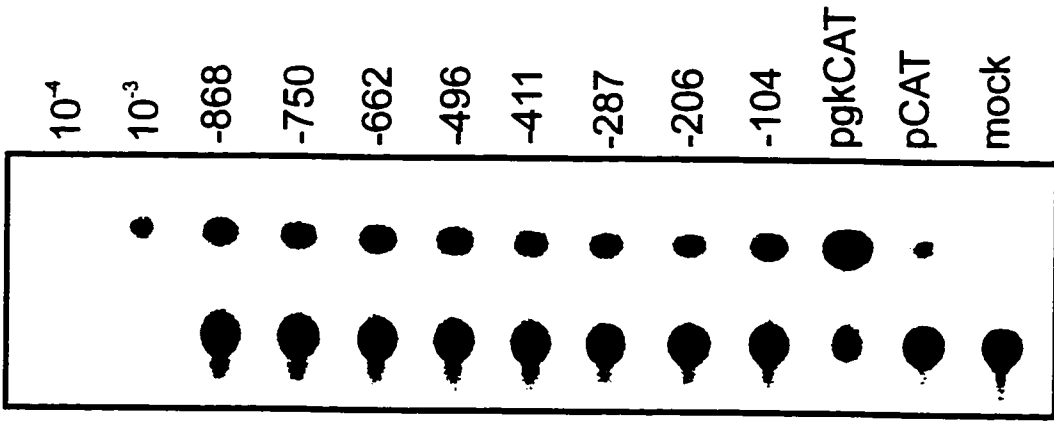

Figure 6: Quantification of the activity of Unp-CAT reporter minigene constructs in 293T cells

CAT activities for each construct were measured using a Storm fluorimeter (Molecular Dynamics) with ImageQuant software. The data shown represent results obtained from three independent experiments (n=3). Data are mean \pm SEM (bars) values.

CAT Analysis of Unp Promoter Deletions in 293T Cells

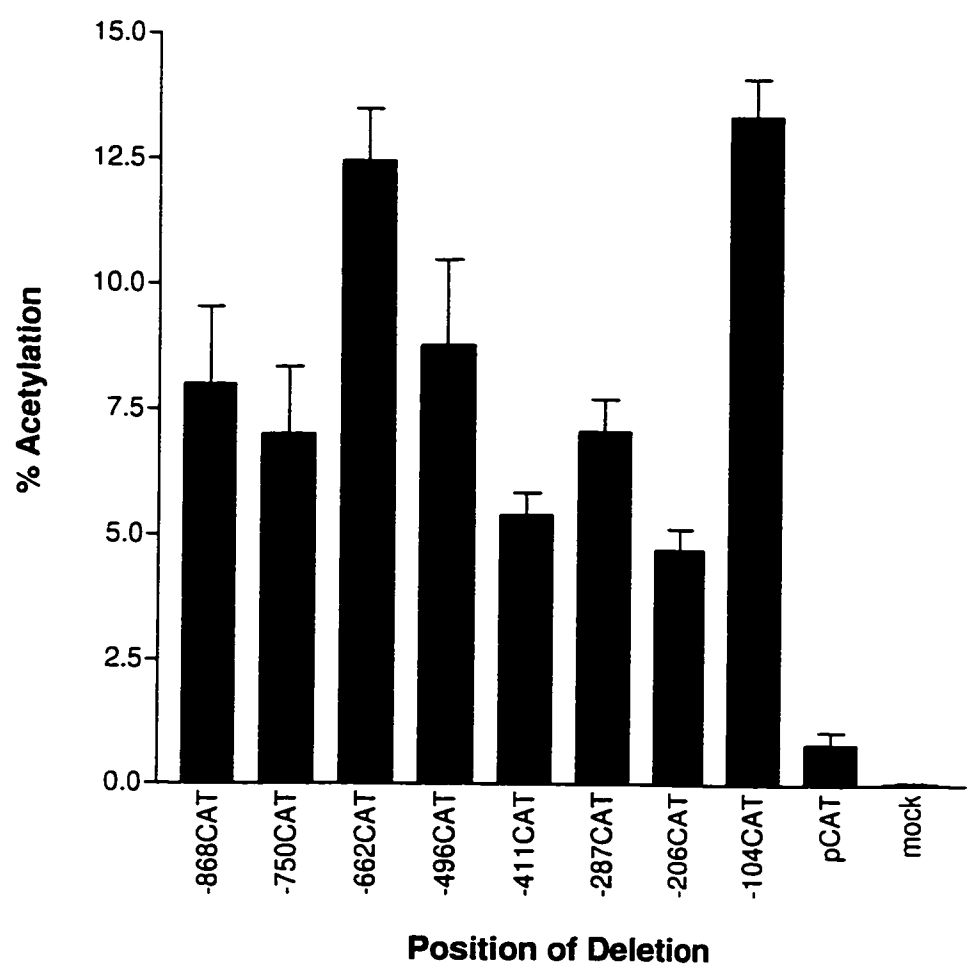

Figure 7: CAT analysis of Unp promoter deletions in P19 cells

Activities of the CAT minigene constructs were determined by transient transfection into cultures of the P19 embryonal carcinoma cell line followed by measurement of CAT activity in cellular extracts. The activities shown are representative of results obtained from three independent sets of transfections (n=3). Numbers above each lane indicate the identity of the deletion construct used for each transfection. The positive control for CAT activity is pgkCAT, in which the phosphoglycerate kinase promoter drives expression of the CAT gene. The negative controls are the promoterless vector, pCAT, and a mock transfection containing no DNA. 10^{-3} and 10^{-4} refer to dilutions of a reference standard for acetylated products (provided by Molecular Probes).

P19 Cells

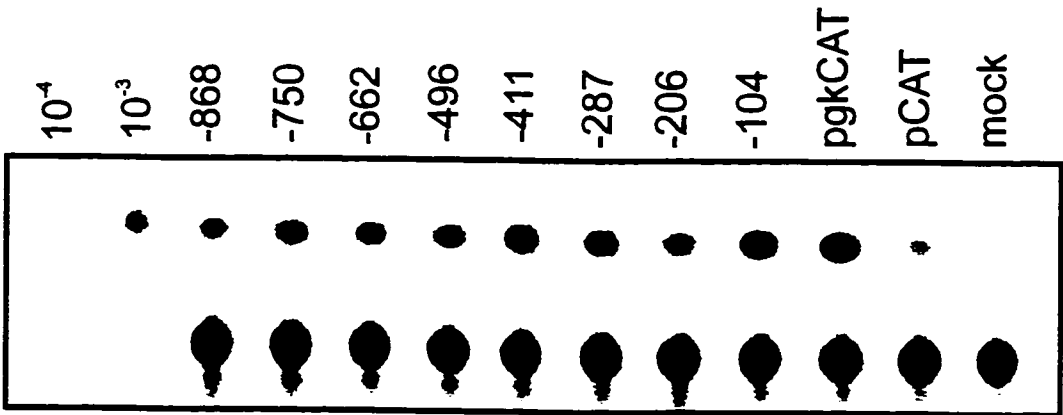
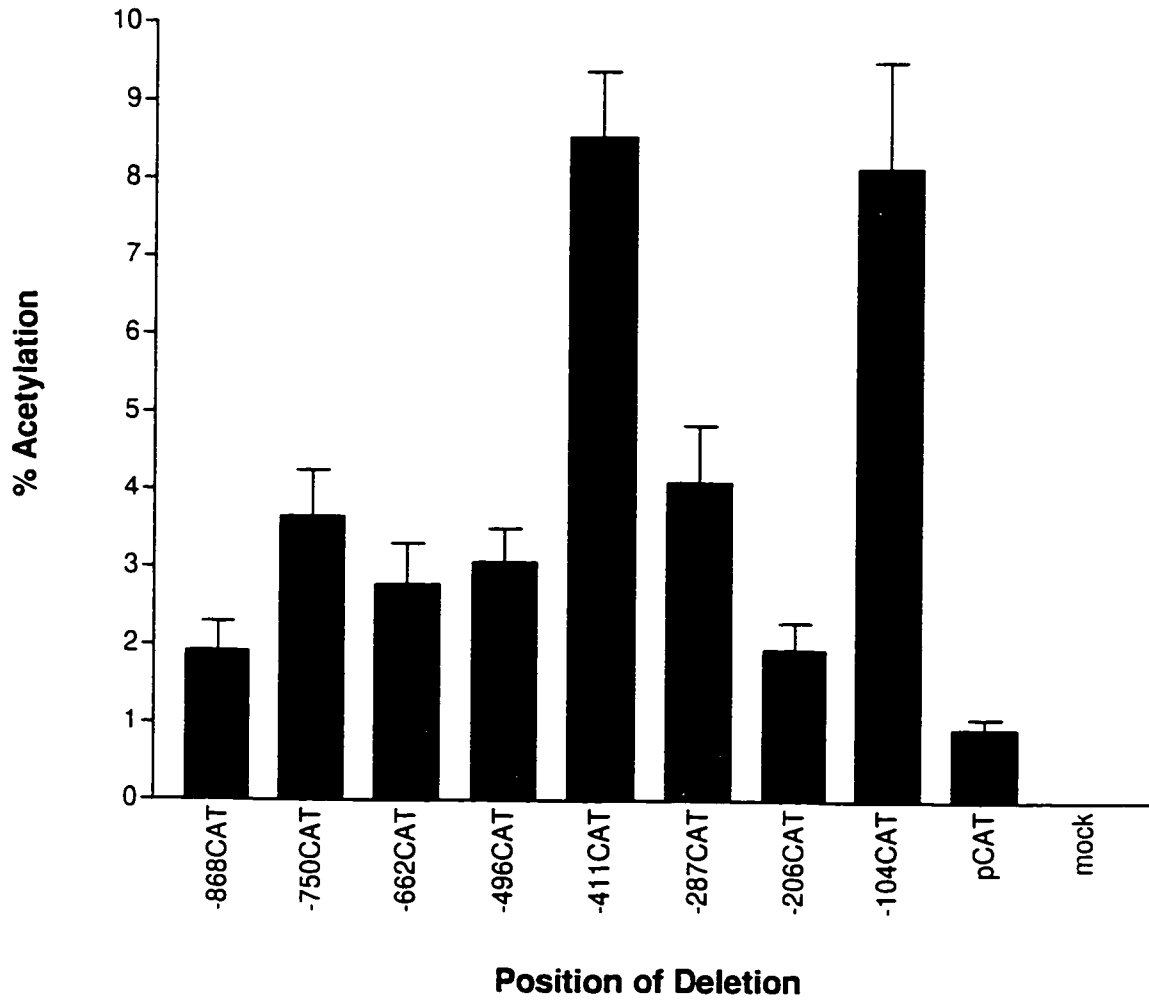

Figure 8: Quantification of the activity of Unp-CAT reporter minigene constructs in P19 cells

CAT activities for each construct were measured using a Storm fluorimeter (Molecular Dynamics) with ImageQuant software. The data shown represent results obtained from three independent experiments (n=3). Data are mean \pm SEM (bars) values.

CAT Analysis of Unp Promoter Deletions in P19 EC Cells



to within 104 nucleotides upstream of the transcriptional start site. Second, all Unp promoter deletion constructs displayed CAT activity in both orientations relative to the CAT gene, demonstrating that the promoter was functional in both orientations under the experimental conditions utilized (data not shown). Finally, construct -662CAT displays higher CAT activity in 293T cells than does -496CAT (Figures 5.6). The significance here is that while -662CAT contains a putative E2F-1 binding site at position -523, whereas this site is absent from -496CAT. To determine more precisely if E2F-1 binding had an effect on Unp promoter activity, a more subtle deletion of the putative E2F-1 binding site was generated. The results from this set of experiments are discussed in section 3.1.2.

Figure 9 shows the sequence of the initial 1.1 kb Eco RI/Sac I genomic DNA fragment used to construct the various Unp promoter deletions. The promoter is GC rich and lacks a TATA box, both hallmarks of a housekeeping gene. Additionally, the promoter contains potential binding sites for the transcription factors Sp1, AP1, AP2 and E2F-1 as determined by a database search using the MatInspector program (63).

3.1.2 Analysis of a Unp promoter construct mutant for a putative E2F-1 binding site

Using -868CAT as template DNA, a Unp promoter construct mutant for a putative binding site for the transcription factor E2F-1 was generated using PCR (See Materials and Methods). The potential E2F-1 binding site at position -523 (TTTGGCGA) is replaced by a Xho I site (CTCGAG) in plasmid -868 Δ CAT (Figure 9). Construct -868 Δ CAT was

Figure 9: Sequence of the Unp promoter

The sequence of the full-length 1.1 kb Eco RI/Sst I genomic fragment containing the Unp promoter is shown. Uppercase letters indicate the Unp cDNA and * denotes the initiating methionine. Italics show the Bgl II restriction sites used to create the original deletion (described in reference 12). Underlined are a few potential binding sites for transcription factors common to several housekeeping genes. The putative E2F-1 binding site is also indicated. (+) indicates the consensus sequence is present in the same orientation of the promoter sequence. (-) denotes that the consensus sequence is present in the opposite orientation.

gaattcagagatctgcctacctctgcctcctgagtgctgggttaaagcctgtgccatca 60

ccgcccgaagaaaacggaatcattgtttcaggaaaaattaagatgcctggacctctgt 120
 SP1 (-)
cggcttcggtggttgctactctctccttgacctggatggctgacaggatacaaaagttgtt 180
 AP1 (+) AP1 (+)
taagacaactttgttttttgcgtctatttatgactttat 240
 AP1 (+)
 tgatgtatgcttttaatcccagcactctggagaaaagggcaaatgggcctaaattcgaga 300

 ctagcctagattacataaacagctccaggacagcagctagaagaaacctgtcccaaaca 360

 acaacaaatttcactattgtgtgcctgtttggcgaacgcgtgccacagtgtctgtgtcga 420
 E2F-1 (+)
gaacaaaggacaactttaagagtcagttttcttttccacttttacacgggttctgggg 480
 AP1 (-)
atcaaaccagttgtcaccacgtagccatcgcgccggcccttgtttgaacaactatta 540
 AP1 (-)
 atggctggaccacaccggacagtcagatctcaatgcgtccgtgtgcacttggtacagg 600

 ggctgccgaggcagtaaattcaatctcgcatttaggcagtccttgctgaaagccgcatgga 660

 accgagtggaaacaagaaaagcaagcgccaggctcctcctgcacggatttagcatcaggc 720
 SP1 (+)
taacctcacaggccaggatggagcgaqtgactgatgggtcgagggccggccagcagtcag 780
 AP1 (+) SP1 (+) AP1 (-)
atcgcaggagccgctcagacacgggtggatgtggccgcgcctctggcgtccagcctgc 840
 AP2 (-)
ttctgtccgcttcggctccggagagggggcgggggggggttaacagcgcgtgggggcgggga 900
 AP2 (-) SP1 (+) AP2 (-) SP1 (+)
 gaagaggcgaagtcgacggcgggtgcccggcgcgcgcacgtgcgtggttacgtgcgtgcg 960

tgggcgcggcccatagcacgCCGTGCGCTAGGCGGATGTCCGGGCCGGCTGGGCCGGGGC 1020
 SP1 (+)
 GCGGACGAGATGGCGGAAGGCCGGGGCAGCCGTGAGCGACCGGATGTGGAGACCCAGAA 1080
 *
 GACGGAGCTC 1090

sequenced to verify the absence of additional mutations. Constructs -868CAT and -868 Δ CAT were each co-transfected along with pDM2 into 293T cells and lysates were analyzed for CAT activity. The results obtained from the P19 cell line for this set of experiments are not shown because the low CAT activity of -868CAT in P19 cells (Figures 7, 8) made it difficult to accurately quantify differences in reporter gene activity resulting from the E2F deletion. The same trend in CAT activities for each construct was consistently observed in 293T cells (Figures 10, 11). These data show that the loss of the potential E2F-1 binding site in -868 Δ CAT reduced the CAT activity of this construct approximately two-fold relative to the CAT activity detected from -868CAT (16% acetylation and 8% acetylation from -868CAT and -868 Δ CAT, respectively). This data suggests that Unp promoter activity may be influenced by the binding of the transcription factor E2F-1. Further supportive evidence for an E2F-1 binding site in the Unp promoter has been shown by electrophoretic mobility shift assays (data not shown). Complete verification of this result, however, is ongoing.

3.2 Analysis of Unp-LacZ transgenic mice

3.2.1 Genotyping of transgenic mice

Blastocysts were microinjected with a 3.8 kb Hind III/Kpn I fragment containing a 411 bp fragment of the Unp promoter (derived from -411CAT; See Figure 4) driving expression of the *E. coli* β -galactosidase (LacZ) reporter gene (Figure 12). The 411 bp region

Figure 10: CAT analysis of a Unp promoter mutated for a potential E2F-1 binding site

A CAT minigene (-868 Δ CAT) mutant for a potential E2F-1 binding site was constructed by PCR using -868CAT as template DNA. The potential E2F-1 binding site (**tttggega**) in -868CAT is replaced by a Xho I site in -868 Δ CAT (**ctcgag**; see Materials and Methods). Activities of the CAT minigene constructs were determined by transient transfection into cultures of the 293T cell line followed by measurement of CAT activity in cellular extracts. The activities shown were obtained from triplicate transfections and are representative of results from two independent experiments (n=2). The letters above each lane indicate the identity of the deletion construct used for each transfection. The positive control for CAT activity is pgkCAT, in which the phosphoglycerate kinase promoter drives expression of the CAT gene. The negative controls are the promoterless vector, pCAT, and a mock transfection containing no DNA. 10^{-3} and 10^{-4} refer to dilutions of a reference standard for acetylated products (provided by Molecular Probes).

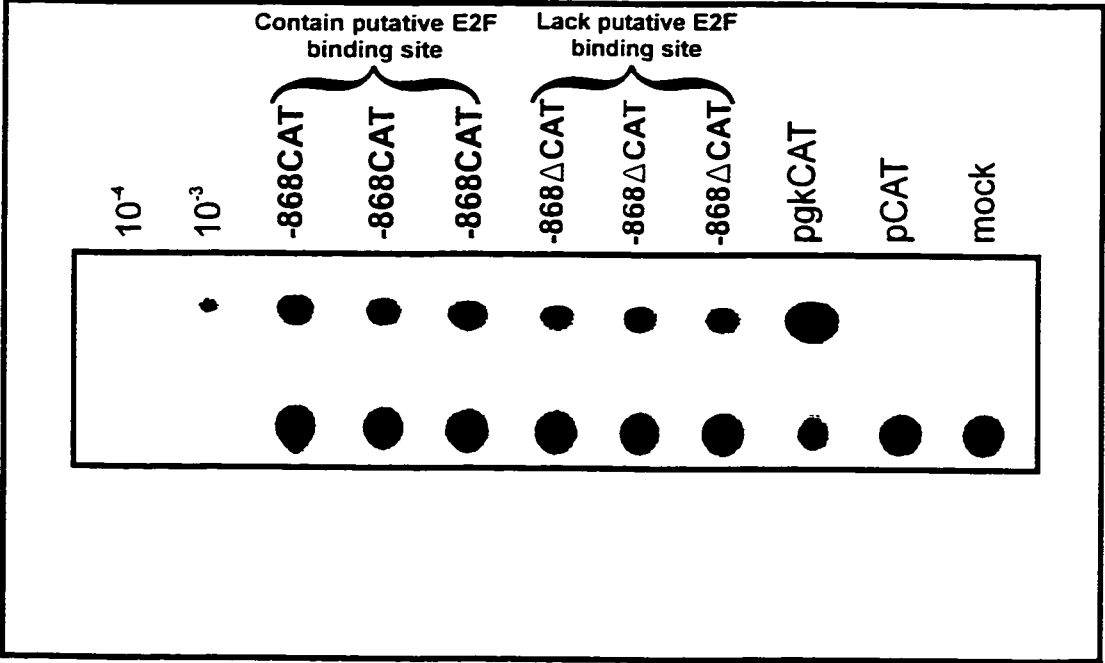

Figure 11: Quantification of CAT activity for a Unp promoter mutated for a potential E2F-1 binding site

CAT activities for each construct were measured using a Storm fluorimeter (Molecular Dynamics) with ImageQuant software. Two independent experiments were performed with each sample transfected in triplicate each time (n=2). Data are mean \pm SEM (bars) values.

Effect of E2F Binding Site on Unp Promoter Activity in 293T Cells

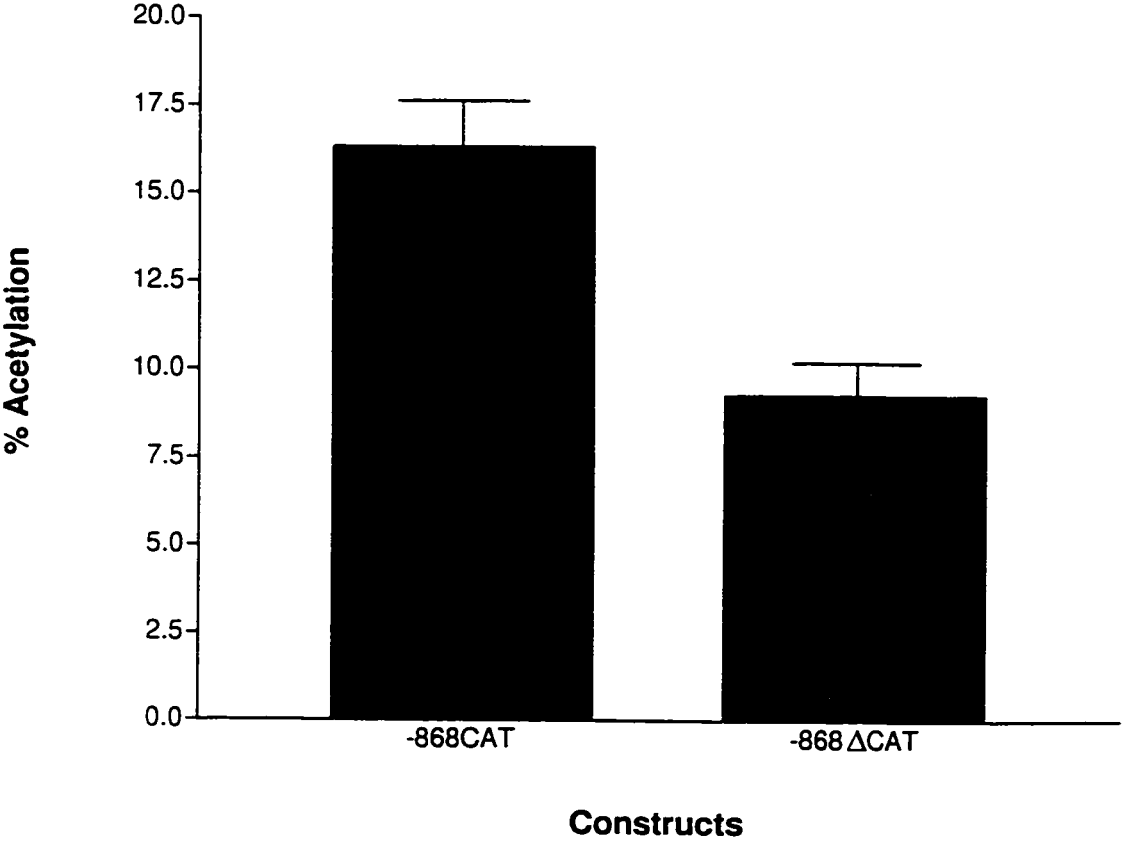
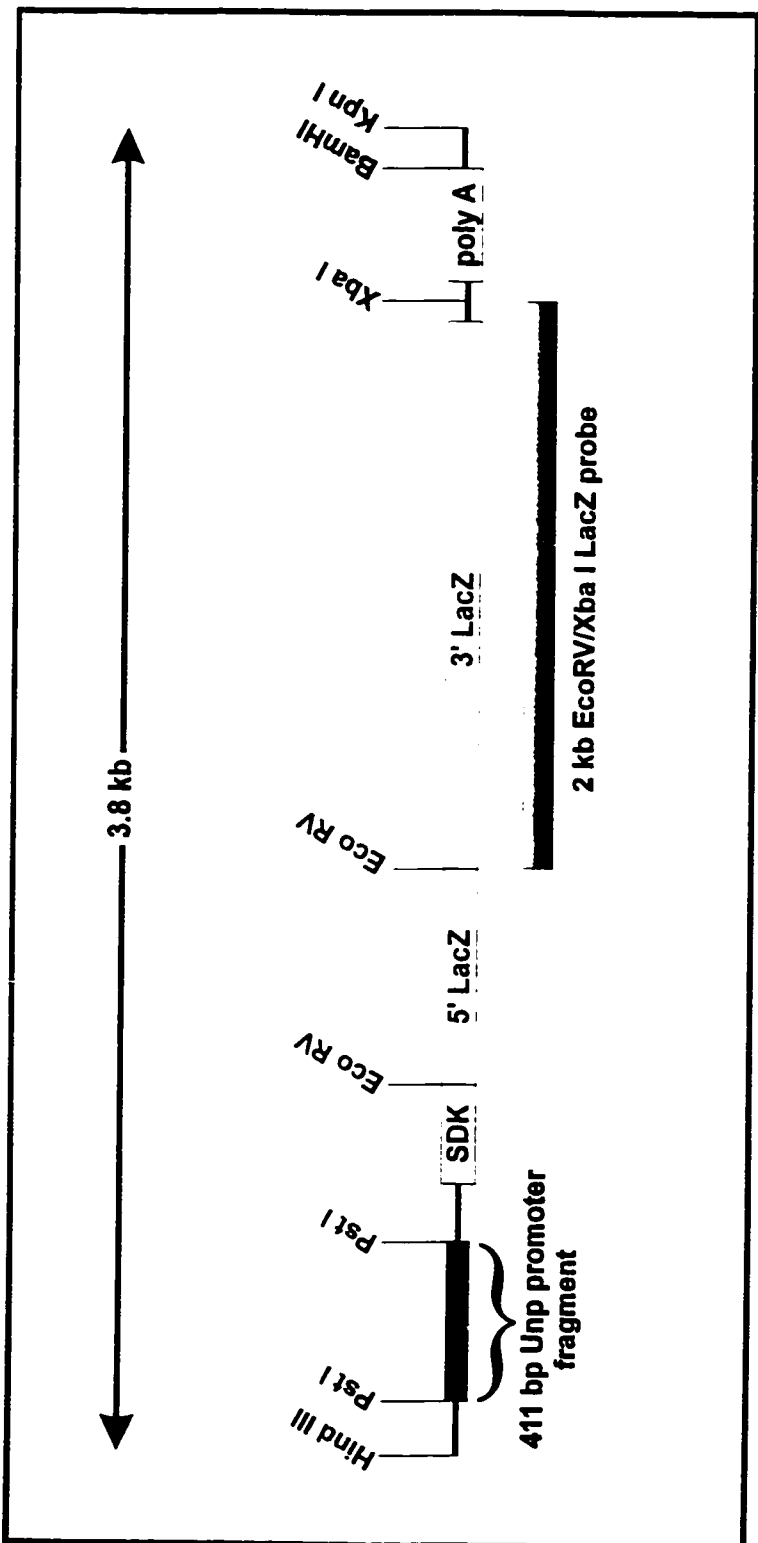

Figure 12: Schematic of the 3.8 kb Unp-LacZ transgene

A 3.8 kb Hind III/Kpn I fragment containing a 411 bp Unp promoter fragment driving expression of the β -galactosidase reporter gene was microinjected into blastocysts. The 2kb Eco RV/Xba I probe used for Southern and Northern analysis which spans the 3' end of the LacZ gene is also shown.

SDK: Shine-Dalgarno/Kozak sequences for prokaryotic and eukaryotic translation, respectively; polyA: SV40 polyadenylation sequence.



was chosen because at the time of construction of the transgenic cassette, the panel of deletions in Figure 4 had not yet been designed and significant CAT activity had been previously reported in this region by M. DiFruscio (12). One of the goals for this set of experiments was to determine if the Unp promoter would prove useful as a general-purpose transgenic promoter by permitting expression of the transgene in a wide range of tissues. It was hypothesized that since the 411bp fragment possessed much higher CAT activity in vitro than the full-length promoter (12), this fragment would prove to be more active in vivo as well.

A total of 111 potential founders were screened for the presence of the transgene, and four independent lines were established (3470♀, 3587♂, 3627♀ and 3630♂) that contained a 3.8 kb genomic fragment which hybridized with a 2 kb Eco RV/Xba I LacZ probe (shown in Figure 12). F1 heterozygotes were obtained for each line, as verified by Southern blot analysis (Figures 13-16). Homozygous mice are currently being generated for each line. The verification of homozygosity will be accomplished through test crosses with wild-type mice.

3.2.2 Northern blot analysis of transgenic mice

Total RNA was isolated from various tissues of F1 heterozygous mice and analyzed by Northern blot for the expression of the LacZ transgene. Initially, RNA was extracted from tissues of a wild-type mouse (3874♂) and a heterozygous F1 progeny (3876♂) from the 3470♀ line. Transgene expression was detectable only in the testis, while a background

Figure 13: Genotype of progeny derived from founder 3470♀

Southern blot analysis of genomic DNA from mouse tails digested with Bam HI detected a band of approximately 3.8 kb in all F1 heterozygotes, corresponding to the size of the microinjected fragment. Membranes were probed with a 2kb Eco RV/Xba I LacZ probe and visualized following overnight exposures using a Psi PhosphorImager (Molecular Dynamics). The lower panel is an image of the ethidium bromide stained gel prior to transfer to demonstrate loading of genomic DNA.

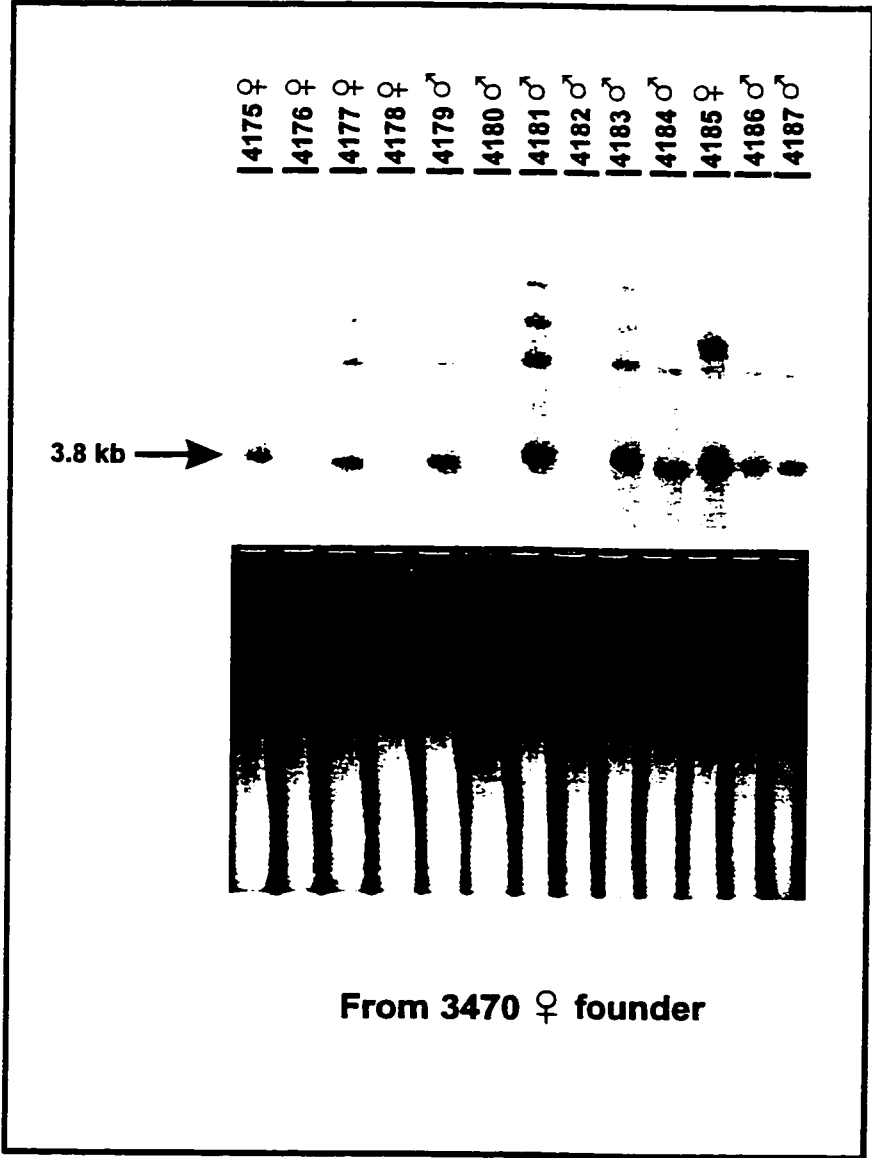

Figure 14: Genotype of progeny derived from founder 3587 σ

Southern blot analysis of genomic DNA from mouse tails digested with Bam HI detected a band of approximately 3.8 kb in all F1 heterozygotes, corresponding to the size of the microinjected fragment. Membranes were probed with a 2kb Eco RV/Xba I LacZ probe and visualized following overnight exposures using a Psi PhosphorImager (Molecular Dynamics). The lower panel is an image of the ethidium bromide stained gel prior to transfer to demonstrate loading of genomic DNA.

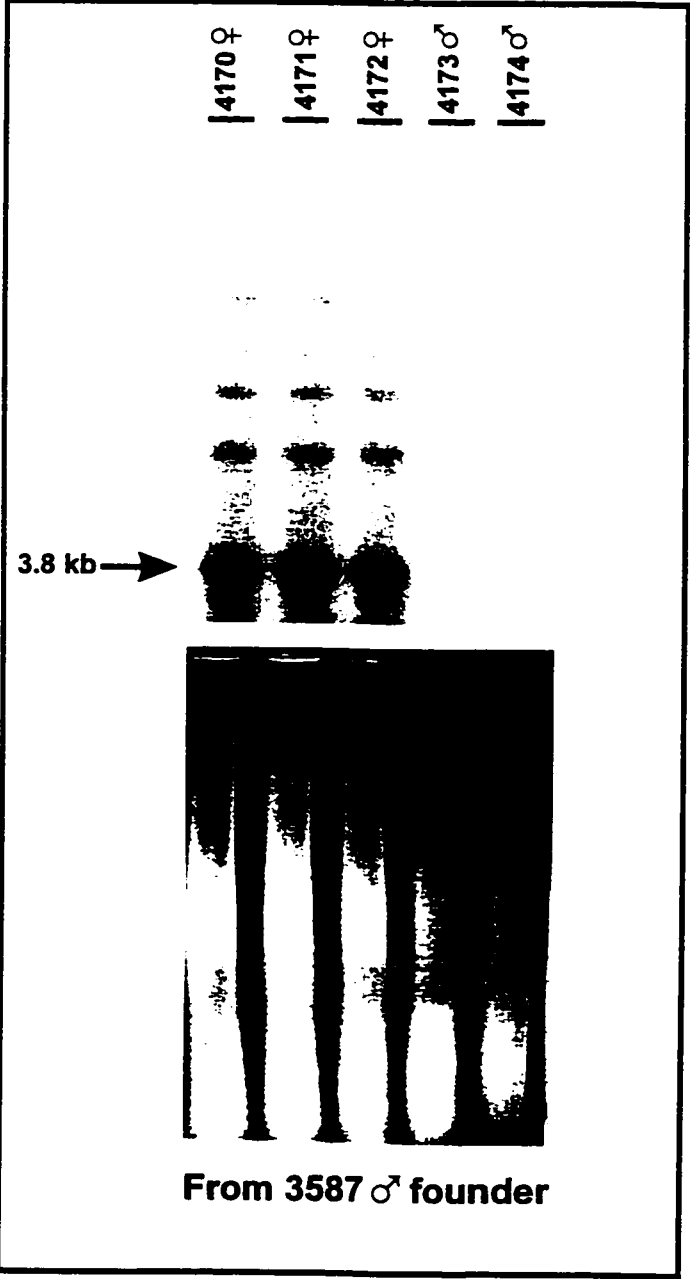

Figure 15: Genotype of progeny derived from founder 3627♀

Southern blot analysis of genomic DNA from mouse tails digested with Bam HI detected a band of approximately 3.8 kb in all F1 heterozygotes, corresponding to the size of the microinjected fragment. Membranes were probed with a 2kb Eco RV/Xba I LacZ probe and visualized following overnight exposures using a Psi PhosphorImager (Molecular Dynamics). The lower panel is an image of the ethidium bromide stained gel prior to transfer to demonstrate loading of genomic DNA.

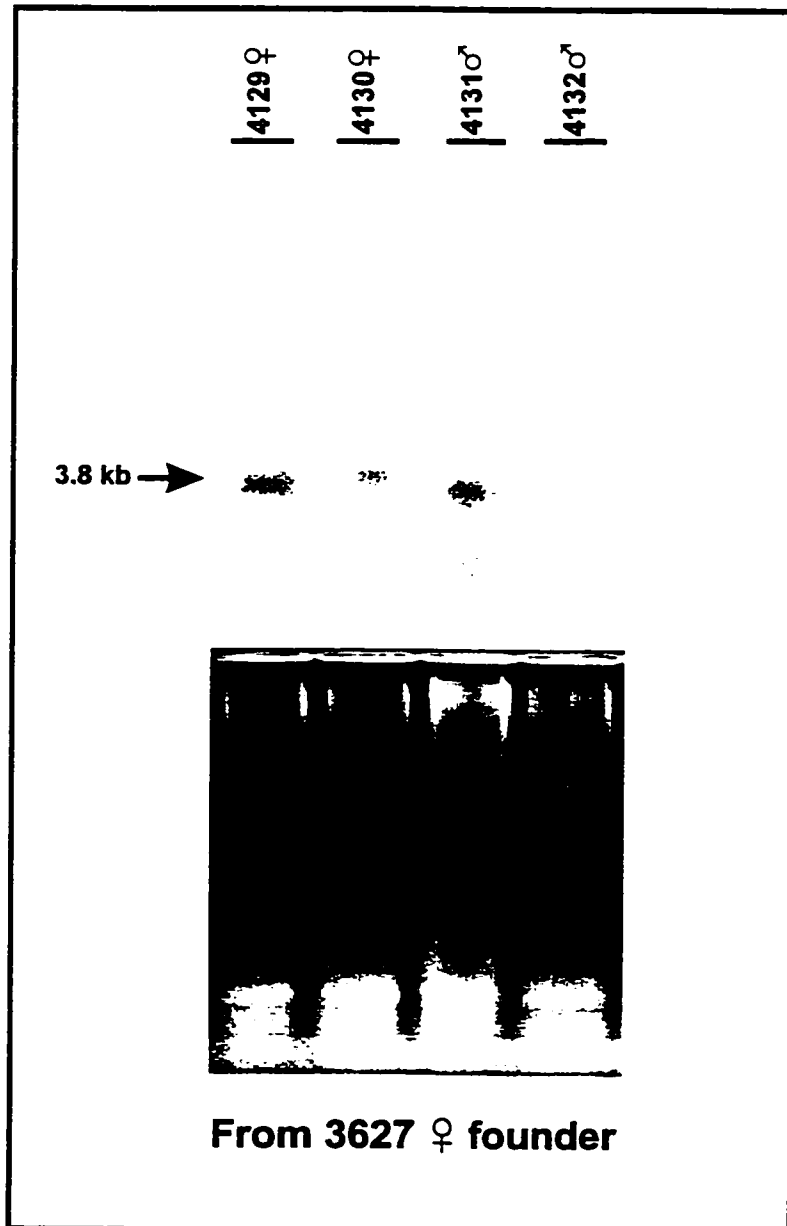
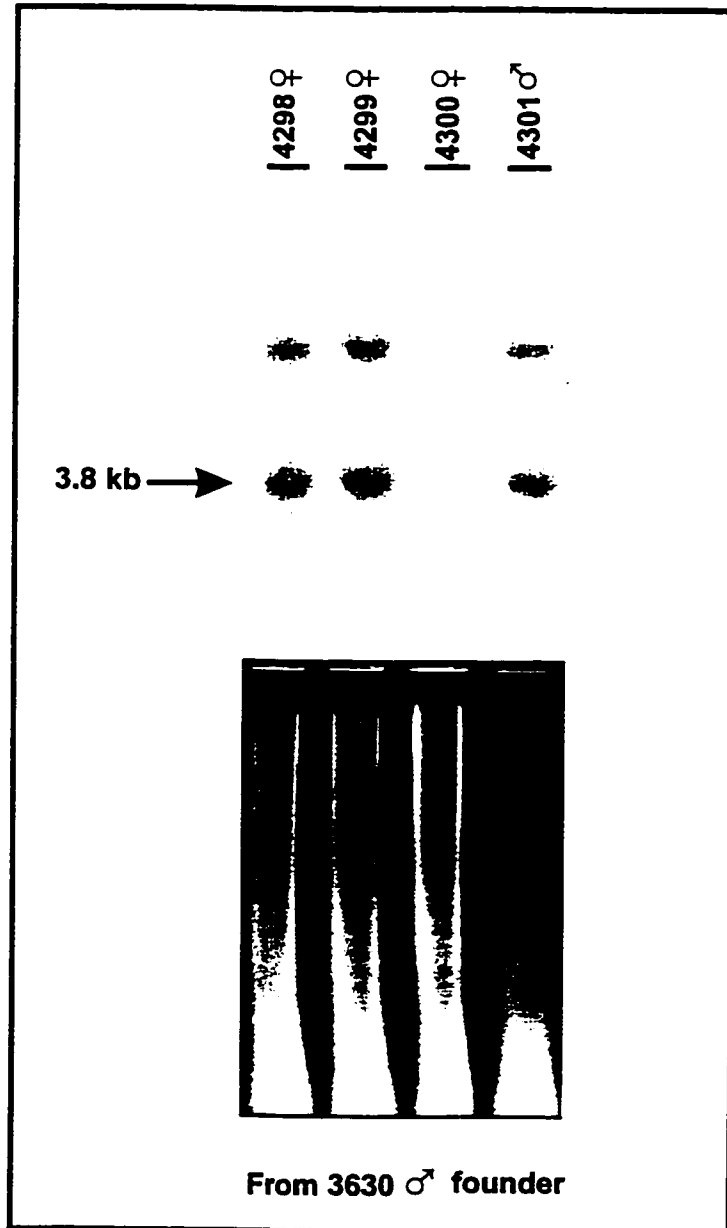

Figure 16: Genotype of progeny derived from founder 3630 σ

Southern blot analysis of genomic DNA from mouse tails digested with Bam HI detected a band of approximately 3.8 kb in all F1 heterozygotes, corresponding to the size of the microinjected fragment. Membranes were probed with a 2kb Eco RV/Xba I LacZ probe and visualized following overnight exposures using a Psi PhosphorImager (Molecular Dynamics). The lower panel is an image of the ethidium bromide stained gel prior to transfer to demonstrate loading of genomic DNA.



smear was detected in brain, kidney and lung samples from transgenic mice (Figure 17). At least three distinct transcripts hybridized to the 2 kb Eco RV/Xba I Lac Z probe in the testis sample, possibly indicating alternatively spliced isoforms of the transgene. To verify the relative amounts of RNA loaded on the gel, the membrane was stripped and reprobed with a fragment containing the full-length Unp cDNA (Figure 18). Unp expression levels shown in Figure 18 were comparable to those reported previously (23), so RNA loading was presumed to be accurate. Next, total RNA was isolated from various tissues of F1 heterozygous females from the other transgenic lines (i.e., the 3587 σ , 3627 η and 3630 σ lines) and analyzed by Northern blot. Tissues examined here included ovaries, kidneys and skeletal muscle. No expression of the transgene was detected in any of the mice examined (data not shown), as the 2kb Eco RV/Xba I LacZ probe failed to hybridize with any distinct transcripts. It appears, therefore, that the expression of the Unp-LacZ transgene is testis-specific.

3.2.3 Analysis of tissue sections from transgenic mice

Tissue sections were prepared using samples from both wild-type mice and F1 heterozygous transgenic males from the 3470 η line and stained with X-GAL to detect expression of the β -galactosidase protein. Tissues analyzed here included kidney, lung, skeletal muscle and testis. As before, expression of the transgene was detectable only in the testis (Figure 19). Closer scrutiny of the transgenic testis revealed that expression is first

Figure 17: Northern blot analysis of transgene expression in adult mouse tissues

Approximately 20 μg of total RNA isolated from adult mouse tissues (brain, heart, kidney, liver, lung, testis) were subjected to Northern blot analysis using the 2kb Eco RV/Xba I LacZ fragment as a probe. Exposures were performed overnight and membranes were visualized using a Psi PhosporImager (Molecular Dynamics). At least three distinct transcripts are detectable in the 3876 σ testis lane. The lower panel is an image of the ethidium bromide stained gel prior to transfer to demonstrate loading of RNA.

3874 σ : wild-type

3876 σ : F1 heterozygote from 3470 f line

3874 brain
3876 brain
3874 heart
3876 heart
3874 kidney
3876 kidney
3874 liver
3876 liver
3874 lung
3876 lung
3874 testis
3876 testis

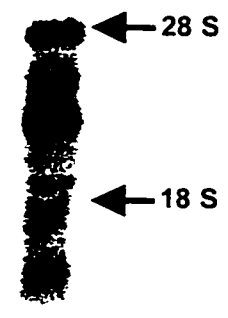

Figure 18: Northern blot analysis of Unp expression in adult mouse tissues

The membrane shown in Figure 17 was stripped and reprobbed with a 3.7 kb fragment containing the full-length Unp cDNA. Exposures were performed overnight and membranes were visualized using a Psi PhosphorImager (Molecular Dynamics). The lower panel is an image of the ethidium bromide stained gel prior to transfer to demonstrate loading of RNA.

3874 σ : wild-type

3876 σ : F1 heterozygote from 3470 φ line

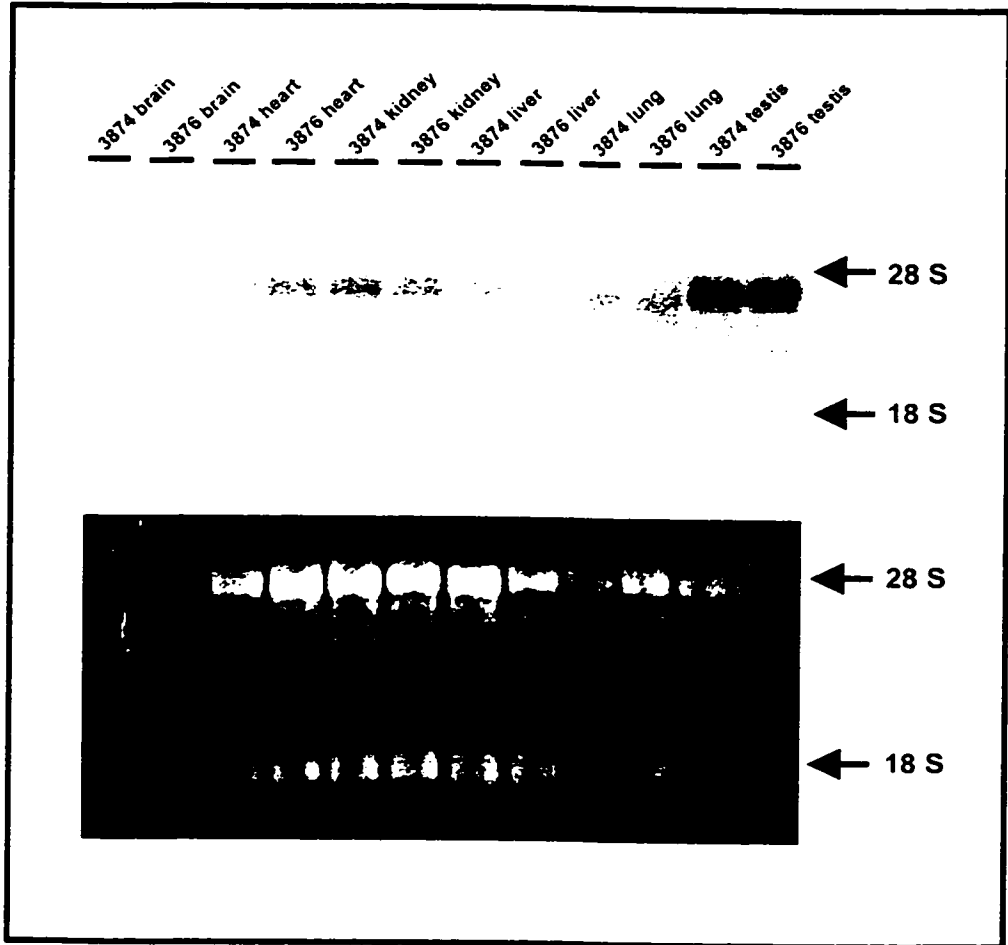
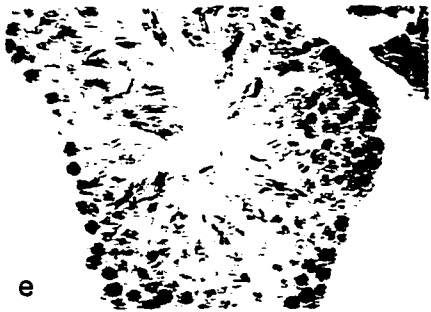
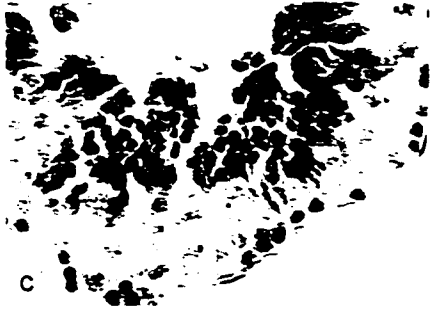
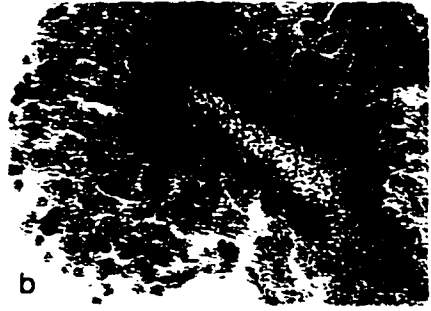
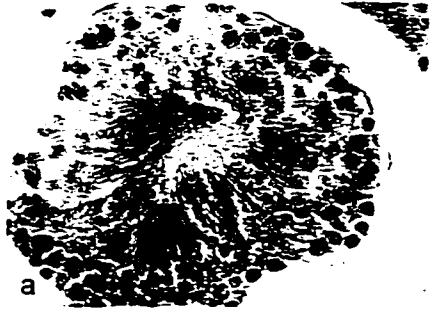

Figure 19: X-GAL staining of testis sections from adult mice

Testis from adult mice were sectioned and stained overnight with X-GAL to detect expression of the β -galactosidase protein. Sections A-D are taken from 4087 σ , a F1 heterozygote of the 3470 φ line, and section E is from 4302 σ (wild-type).



seen in early spermatocytes as a 'spot' which might represent Golgi. This pattern is seen sparsely in all phases of spermatocyte development and persists and increases in the round spermatids. When the round spermatids begin to elongate, the expression changes from the 'spot' pattern to a diffuse cytoplasmic staining. Finally, when the elongate spermatids are released, the LacZ staining is seen in the residual bodies (the spermatid cytoplasm is retained by the Sertoli cells and degraded) (K. Bockelheide, Brown University, personal communication).

4. Discussion

The Unp gene displays characteristics of typical housekeeping genes, including expression in a wide variety of tissues and a GC-rich promoter. However, it is apparent that the human homolog of Unp (Unph) displays a tissue-specific pattern of expression in a subset of lung tumours (22). This discovery raised the possibility that transcription of the Unp gene may be regulated in a cell-specific manner. Results from the CAT analysis of Unp promoter deletions suggest that such regulation may occur at the level of the promoter. One concern might be that the observed differences in CAT activities of the individual deletions between cell types (i.e., 293T, P19) is due to species difference rather than actual differences in promoter function. This was not a concern for this study, however, as extensive experimentation that examined Unp expression patterns in primary human and mouse fibroblasts as well as cell cycle analysis of both Unp and Unph expression indicated no species difference in regulation of expression (Gray, D.A., unpublished). These results were not surprising, given the fact that Unph is 90% and 85% identical to Unp at the protein and nucleotide level, respectively, suggesting that both genes are regulated similarly. Finally, if there are differences in regulation of gene expression between 293T and P19 cells, it is more likely that these differences have arisen due to transformation events both cell lines have been subjected to than due to species differences per se. Initially, attempts were made to perform the promoter function analysis in SCLC cell lines, but technical problems (i.e., low transfection efficiency) prevented this approach.

Although there are a variety of mechanisms which might account for the up-regulation of Unph mRNA in lung cancers (for a full discussion, see Sections 1.10, 1.11 of Introduction), it is quite possible that there are regulatory elements within the Unp promoter which only become active in specific cell types or in response to a particular signal. The Unp promoter contains many binding sites for factors common to housekeeping genes (i.e., Sp1, AP1, AP2) that contribute to basal transcriptional levels in a wide range of tissues. However, the gene also possesses a single transcription start site (Gray, D.A., unpublished data), implying Unp may potentially be regulated differently than other CpG-type genes, many of which contain multiple transcription start sites (75). To support the hypothesis of tissue-specific regulation, there are several examples of housekeeping genes which exhibit tissue-specific activity. For instance, the murine Surf-4 and Surf-5 genes (part of the surfeit locus which contains at least six housekeeping genes) have GC rich promoters and are expressed in a wide variety of tissues (17). However, the levels of alternatively spliced isoforms of both Surf-4 and Surf-5 mRNA are dramatically different between tissues, implying tissue-specific post-transcriptional processing mechanisms are at work (17). Additionally, levels of mRNA for PIM-1 (a proto-oncogene that encodes a cytoplasmic serine-threonine kinase) show a wide variation between various tissues and cell lines, although the gene is transcribed from a GC-rich housekeeping promoter (54). Finally, deregulation of Unp expression may also result from changes in expression of a variety of positive and negative transcription factors, including c-myc, c-fos and c-jun (65,69,92). These factors are often found to be

expressed at abnormal levels in various tumours which may contribute to deregulating Unp expression in lung tumours. Clearly, control of housekeeping gene expression can be exerted at many levels and can occur in a tissue or cell-specific fashion.

CAT analysis of a Unp promoter construct lacking a putative E2F-1 binding site suggests that E2F-1 is capable of binding to and transactivating the promoter (Figures 10, 11). Further confirmation of preliminary results from mobility shift assays should verify this finding. This result is particularly intriguing because of the observation that E2F-1 undergoes ubiquitin-mediated proteolysis (25,28). E2F-1 is a transcription factor whose expression during the cell cycle is tightly regulated and which has binding sites in several genes associated with cell cycle progression (14). We are interested in the possibility that Unp is capable of regulating E2F-1 activity through a deubiquitinating mechanism. In this scenario, an alteration in the levels of Unp enzyme (i.e., during tumorigenesis) could substantially alter the stability of E2F-1 and contribute to uncontrolled cell cycle progression (93). A feedback loop involving Unp and E2F-1 could conceivably be initiated under these conditions. If Unp has an effect on E2F-1 stability, one would predict that in mice which are homozygous null for Unp that E2F-1 protein levels would be altered relative to levels in wild-type mice.

One of the goals in creating Unp-LacZ transgenic mice was to determine if the Unp promoter would be useful in future transgenic experiments as a general-purpose transgenic promoter. Often, tissue-specific activity is a problem with various transgenic promoters

when the goal is to achieve global tissue expression (68). It was hoped that the postulated housekeeping role for the Unp promoter would facilitate expression of the transgene in a wide variety of tissues. However, expression of the Unp-LacZ transgene appears to be limited to the testis in adult mice (Figure 17). This result would appear to indicate that the Unp promoter will not be entirely useful as a general-purpose promoter for future transgenic applications, but may prove useful in testes research. The X-GAL staining patterns in the testis do yield important clues as to which cells express Unp within the tissue, however. The observation that the transgene appears to be highly expressed in the round spermatids is informative due to the fact that these cells are postmeiotic and undergo rapid chromatin remodelling in order to ensure proper genome packaging in the mature spermatid. The fact that the Unp promoter seems to be most active in these cells may imply a role for Unp in the remodeling process. Other evidence that supports a role for Unp in testis development include the observations that testis is the only tissue that has an overabundance of Unp mRNA and there is a testis-specific isoform which may arise from alternative splicing (23).

Although endogenous Unp is expressed in all tissues, the possibility remains that it plays a specific role in testis. This could result from differences in compartmentalization of Unp protein in testis as compared with other tissues as well as differences in the phosphorylation status of Unp in testis. Other ubiquitin-related genes have shown similar expression patterns in the testis. For instance, studies have shown that a rat homolog of the *Saccharomyces cerevisiae* ubiquitin conjugating enzymes UBC4 and UBC5, 8A, is

expressed mainly in round spermatids (91). Immunoblot analysis showed that the 8A protein is found not only in subfractions of germ cells enriched in round spermatids but also in subfractions containing residual bodies extruded from more mature spermatids, much like the staining found in the Unp-LacZ transgenic mice. This data supports the hypothesis that the ubiquitin-proteasome pathway plays an important role in testis function, possibly as a regulator of spermatogenesis. Indeed, there is more evidence of a role for ubiquitin in this complex pathway. The yeast ubiquitin-conjugating enzyme RAD 6 and its human homologs hHR6A and hHR6B (41) are implicated in postreplication repair and damage-induced mutagenesis (46). It is postulated that RAD 6 may modulate chromatin structure via histone ubiquitination (34). Additionally, inactivation of the hHR6B homolog in mice has been demonstrated to cause male infertility due to failures in spermatogenesis during the postmeiotic condensation of chromatin in spermatids (66). Interestingly, like Unp, both hHR6 proteins are expressed in all mammalian tissues and cell types examined, yet still appear to play an important role in testis function (40). It has been proposed that deubiquitination of histones serves as the trigger for condensation (50), and there is indirect evidence that ubiquitinated histones are crucial to chromatin remodelling in male germ cells (66). Ubiquitinated histones are most abundant in interphase cells and are completely removed from chromatin during DNA condensation at mitosis (52). An attractive hypothesis would involve Unp acting as a deubiquitinating enzyme to remove mono-ubiquitin tags from histones, thereby facilitating chromatin condensation. In support of this model, Unp has been

shown to be capable of cleaving ubiquitin from histone H2A in vitro (Baker, R.T., unpublished data). Clearly, a definitive role for Unp in chromatin remodelling requires further investigation. It remains to be seen if the staining patterns will be identical for all Unp-LacZ transgenic lines, or whether the expression patterns seen to date result from founder effect (80) and are representative of only one line. It could also be argued that the Unp-LacZ transgenic lines shown here are not representative of true endogenous Unp expression, on the basis that only 411 bp of the Unp promoter is used to drive expression of the LacZ transgene. It is conceivable that a different expression pattern might be observed in transgenic mice that utilized the full-length Unp promoter to drive expression of LacZ, as important regulatory elements may have been removed in creating the 411 bp promoter fragment. Additionally, if transgene expression in these transgenic mice employing the full-length Unp promoter was detected in several tissues, this might help to identify which element(s) in the 411 bp fragment is/are responsible for the testis-specific expression phenotype. A search of promoter elements that are found in some testis-specific genes was performed on the 411 bp promoter fragment using the MatInspector program (63), however, no consensus sequences were found.

5. Conclusion

The Unp gene has a housekeeping role in maintaining intracellular homeostasis, but also displays tissue-specific expression in various lung tumours. This supports a role for the gene in tumorigenesis, but it is unclear at this point what effect overexpression of Unp exerts at the molecular level inside the cell. In order to understand the oncogenic properties of Unp, its *in vivo* substrate(s) must first be identified. The goal of ongoing gene targeting experiments in mice is to identify which proteins are affected by the absence of functional Unp enzyme. That is, to determine if the stability of specific substrates are altered in a Unp-deficient background. Hopefully, these experiments will answer many questions as to the nature of Unp's *in vivo* function(s) and provide clues as to how the gene contributes to tumour formation when overexpressed.

The mechanisms that cause the overexpression of Unp are unknown at the present time, although there is evidence that transcriptional control of expression plays a large role. The data presented in this thesis support a role for cell-specific regulation of Unp promoter activity. One mechanism that has not yet been mentioned is the possibility of transcriptional attenuation in regulating expression of Unp. It is conceivable that premature transcriptional termination within the Unp gene could be one of the mechanisms regulating the alterations in steady state levels of Unp mRNA. One way of verifying such a hypothesis would be to conduct nuclear run-on assays of nascent RNA from normal cells and tumour cells and determine if there are differences in the transcripts produced in each. Finally, the possibility

that Unp promoter mutations may contribute to a loss of transcriptional control in lung tumours has not yet been investigated. To date, no evidence has been reported that the Unp promoter is mutated in lung cancers, although this phenomenon has been reported in sporadic cases (8.78).

The fact that E2F-1 binding to the Unp promoter appears to exert an effect upon the activity of the promoter is informative because E2F-1 is cell cycle regulated, is oncogenic and is degraded by the ubiquitin-proteasome pathway. To definitively prove a physical interaction between Unp and E2F-1, colocalization experiments could be performed either by immunoprecipitation or by immunofluorescence using confocal microscopy. Because the subcellular localization of Unp is still uncertain, it is difficult to say whether both proteins reside in the same cellular compartment.

We are particularly interested in the hypothesis that deregulating Unp expression contributes to tumorigenesis by altering the steady state level(s) of important growth regulatory factors. It is conceivable that a perturbation in Unp enzyme levels substantially affects the stability of proteins which play a role in cellular proliferation and which normally undergo ubiquitin-mediated proteolysis. It is unlikely, however, that deregulation of Unp expression alone is sufficient for tumorigenesis.

References

1. **Amerik, A. Y., S. Swaminathan, B. A. Krantz, K. D. Wilkinson, and M. Hochstrasser.** In vivo disassembly of free polyubiquitin chains by yeast Ubp14 modulates rates of protein degradation by the proteasome. *EMBO J.* 16: 4826-4838. 1997.
2. **Baker, R. T., J. W. Tobias, and A. Varshavsky.** Ubiquitin-specific proteases of *Saccharomyces cerevisiae*. Cloning of UBP2 and UBP3, and functional analysis of the UBP gene family. *J. Biol. Chem.* 267: 23364-23375. 1992.
3. **Beal, R., Q. Deveraux, G. Xia, M. Rechsteiner, and C. Pickart.** Surface hydrophobic residues of multiubiquitin chains essential for proteolytic targeting. *Proc. Natl. Acad. Sci. U. S. A.* 93: 861-866. 1996.
4. **Beijersbergen, R. L. and R. Bernards.** Cell cycle regulation by the retinoblastoma family of growth inhibitory proteins. *Biochim. Biophys. Acta* 1287: 103-120. 1996.
5. **Bram, R. J., N. F. Lue, and R. D. Kornberg.** A GAL family of upstream activating sequences in yeast: roles in both induction and repression of transcription. *EMBO J.* 5: 603-608. 1986.
6. **Bucher, P.** Weight matrix descriptions of four eukaryotic RNA polymerase II promoter elements derived from 502 unrelated promoter sequences. *J. Mol. Biol.* 212: 563-578. 1990.
7. **Chen, Z. and C. M. Pickart.** A 25-kilodalton ubiquitin carrier protein (E2) catalyzes multi-ubiquitin chain synthesis via lysine 48 of ubiquitin. *J. Biol. Chem.* 265: 21835-21842. 1990.
8. **Chen, Z., K. A. Storthz, and E. J. Shillitoe.** Mutations in the long control region of human papillomavirus DNA in oral cancer cells, and their functional consequences. *Cancer Res.* 57: 1614-1619. 1997.
9. **Chen, Z. J., L. Parent, and T. Maniatis.** Site-specific phosphorylation of IkappaBalpha by a novel ubiquitination-dependent protein kinase activity. *Cell* 84: 853-862. 1996.
10. **Davies, S. W., M. Turmaine, B. A. Cozens, M. DiFiglia, A. H. Sharp, C. A. Ross, E. Scherzinger, E. E. Wanker, L. Mangiarini, and G. P. Bates.** Formation of neuronal intranuclear inclusions underlies the neurological dysfunction in mice transgenic for the HD mutation. *Cell* 90: 537-548. 1997.

11. **Delany, A. M., J. M. Pash, and E. Canalis.** Cellular and clinical perspectives on skeletal insulin-like growth factor I. *J. Cell Biochem.* 55: 328-333. 1994.
12. **Di Fruscio, M., A. C. Gilchrist, R. T. Baker, and D. A. Gray.** Genomic structure of Unp, a murine gene encoding a ubiquitin-specific protease. *Mol. Cell. Biol.* In review: 1997.
13. **Di Fruscio, M., H. Weiher, B. C. Vanderhyden, T. Imai, T. Shiomi, T. A. Hori, R. Jaenisch, and D. A. Gray.** Proviral inactivation of the Npat gene of Mpv 20 mice results in early embryonic arrest. *Mol. Cell Biol.* 17: 4080-4086. 1997.
14. **Farnham, P. J., J. E. Slansky, and R. Kollmar.** The role of E2F in the mammalian cell cycle. *Biochim. Biophys. Acta* 1155: 125-131. 1993.
15. **Frenster, J. H.** Ultrastructural probes of chromatin during cell differentiation and cell division within living human bone marrow cells. pp. 419-28. In: *Hidvegi, E.J. et al. .. ed. Biochemistry of the cell nucleus: mechanism. and. regulation. of. gene expression. Amsterdam.. North-Holland.. : 1975.*
16. **Furst, P. and D. Hamer.** Cooperative activation of a eukaryotic transcription factor: interaction between Cu(I) and yeast ACE1 protein. *Proc. Natl. Acad. Sci. U. S. A.* 86: 5267-5271. 1989.
17. **Garson, K., T. Duhig, and M. Fried.** Tissue-specific processing of the Surf-5 and Surf-4 mRNAs. *Gene Expr.* 6: 209-218. 1996.
18. **Gilchrist, A. C., D. A. Gray, and R. T. Baker.** A ubiquitin-specific protease that efficiently cleaves the ubiquitin-proline bond. *J. Biol. Chem.* 1997.
19. **Ginsberg, D., G. Vairo, T. Chittenden, Z. X. Xiao, G. Xu, K. L. Wydner, J. A. DeCaprio, J. B. Lawrence, and D. M. Livingston.** E2F-4, a new member of the E2F transcription factor family, interacts with p107. *Genes Dev.* 8: 2665-2679. 1994.
20. **Goldknopf, I. L. and H. Busch.** Remarkable similarities of peptide fingerprints of histone 2A and nonhistone chromosomal protein A24. *Biochem. Biophys. Res. Commun.* 65: 951-960, 1975.
21. **Gonda, D. K., A. Bachmair, I. Wunning, J. W. Tobias, W. S. Lane, and A. Varshavsky.** Universality and structure of the N-end rule. *J. Biol. Chem.* 264: 16700-16712. 1989.

22. **Gray, D. A., J. Inazawa, K. Gupta, A. Wong, R. Ueda, and T. Takahashi.** Elevated expression of Unph, a proto-oncogene at 3p21.3, in human lung tumors. *Oncogene* 10: 2179-2183, 1995.
23. **Gupta, K., M. Chevrette, and D. A. Gray.** The UNP proto-oncogene encodes a nuclear protein. *Oncogene* 9: 1729-1731, 1994.
24. **Hateboer, G., E. M. Hijmans, J. B. Nooij, S. Schlenker, S. Jentsch, and R. Bernards.** mUBC9, a novel adenovirus E1A-interacting protein that complements a yeast cell cycle defect. *J. Biol. Chem.* 271: 25906-25911, 1996.
25. **Hateboer, G., R. M. Kerkhoven, A. Shvarts, R. Bernards, and R. L. Beijersbergen.** Degradation of E2F by the ubiquitin-proteasome pathway: regulation by retinoblastoma family proteins and adenovirus transforming proteins. *Genes Dev.* 10: 2960-2970, 1996.
26. **Heller, H. and A. Hershko.** A ubiquitin-protein ligase specific for type III protein substrates. *J. Biol. Chem.* 265: 6532-6535, 1990.
27. **Hochstrasser, M.** Ubiquitin-dependent protein degradation. *Annu. Rev. Genet.* 30:405-39: 405-439, 1996.
28. **Hofmann, F., F. Martelli, D. M. Livingston, and Z. Wang.** The retinoblastoma gene product protects E2F-1 from degradation by the ubiquitin-proteasome pathway. *Genes Dev.* 10: 2949-2959, 1996.
29. **Huang, Y., R. T. Baker, and J. A. Fischer-Vize.** Control of cell fate by a deubiquitinating enzyme encoded by the fat facets gene. *Science* 270: 1828-1831, 1995.
30. **Iguchi-Arigo, S. M. and W. Schaffner.** CpG methylation of the cAMP-responsive enhancer/promoter sequence TGACGTCA abolishes specific factor binding as well as transcriptional activation. *Genes Dev.* 3: 612-619, 1989.
31. **Imai, T., M. Yamauchi, N. Seki, T. Sugawara, T. Saito, Y. Matsuda, H. Ito, T. Nagase, N. Nomura, and T. Hori.** Identification and characterization of a new gene physically linked to the ATM gene. *Genome Res.* 6: 439-447, 1996.
32. **Jariel-Encontre, I., C. Salvat, A. M. Steff, M. Pariat, C. Acquaviva, O. Furstoss, and M. Piechaczyk.** Complex mechanisms for c-fos and c-jun degradation. *Mol. Biol. Rep.* 24: 51-56, 1997.

33. **Jentsch, S.** The ubiquitin-conjugation system. *Annu. Rev. Genet.* 26:179-207: 179-207. 1992.
34. **Jentsch, S., J. P. McGrath, and A. Varshavsky.** The yeast DNA repair gene RAD6 encodes a ubiquitin-conjugating enzyme. *Nature* 329: 131-134. 1987.
35. **Jentsch, S., W. Seufert, and H. P. Hauser.** Genetic analysis of the ubiquitin system. *Biochim. Biophys. Acta* 1089: 127-139. 1991.
36. **Johnson, D. G., J. K. Schwarz, W. D. Cress, and J. R. Nevins.** Expression of transcription factor E2F1 induces quiescent cells to enter S phase. *Nature* 365: 349-352. 1993.
37. **Kalchman, M. A., R. K. Graham, G. Xia, H. B. Koide, J. G. Hodgson, K. C. Graham, Y. P. Goldberg, R. D. Gietz, C. M. Pickart, and M. R. Hayden.** Huntingtin is ubiquitinated and interacts with a specific ubiquitin- conjugating enzyme. *J. Biol. Chem.* 271: 19385-19394. 1996.
38. **Kemler, I. and W. Schaffner.** Octamer transcription factors and the cell type-specificity of immunoglobulin gene expression. *FASEB J.* 4: 1444-1449. 1990.
39. **Kishino, T., M. Lalande, and J. Wagstaff.** UBE3A/E6-AP mutations cause Angelman syndrome. *Nat. Genet.* 15: 70-73. 1997.
40. **Koken, M. H., J. W. Hoogerbrugge, I. Jasper-Dekker, J. de Wit, R. Willemsen, H. P. Roest, J. A. Grootegoed, and J. H. Hoeijmakers.** Expression of the ubiquitin-conjugating DNA repair enzymes HHR6A and B suggests a role in spermatogenesis and chromatin modification. *Dev. Biol.* 173: 119-132. 1996.
41. **Koken, M. H., P. Reynolds, I. Jaspers-Dekker, L. Prakash, S. Prakash, D. Bootsma, and J. H. Hoeijmakers.** Structural and functional conservation of two human homologs of the yeast DNA repair gene RAD6. *Proc. Natl. Acad. Sci. U. S. A.* 88: 8865-8869. 1991.
42. **Kozak, M.** The scanning model for translation: an update. *J. Cell Biol.* 108: 229-241. 1989.
43. **Krek, W., M. E. Ewen, S. Shirodkar, Z. Arany, W. G. Kaelin, Jr., and D. M. Livingston.** Negative regulation of the growth-promoting transcription factor E2F-1 by a stably bound cyclin A-dependent protein kinase. *Cell* 78: 161-172. 1994.

44. **Kyo, S., M. Inoue, Y. Nishio, K. Nakanishi, S. Akira, H. Inoue, M. Yutsudo, O. Tanizawa, and A. Hakura.** NF-IL6 represses early gene expression of human papillomavirus type 16 through binding to the noncoding region. *J. Virol.* 67: 1058-1066. 1993.
45. **Lamph, W. W., V. J. Dwarki, R. Ofir, M. Montminy, and I. M. Verma.** Negative and positive regulation by transcription factor cAMP response element-binding protein is modulated by phosphorylation. *Proc. Natl. Acad. Sci. U. S. A.* 87: 4320-4324. 1990.
46. **Lawrence, C.** The RAD6 DNA repair pathway in *Saccharomyces cerevisiae*: what does it do, and how does it do it? *Bioessays* 16: 253-258. 1994.
47. **Lenardo, M. J. and D. Baltimore.** NF-kappa B: a pleiotropic mediator of inducible and tissue-specific gene control. *Cell* 58: 227-229. 1989.
48. **Liu, C. C., H. I. Miller, W. J. Kohr, and J. I. Silber.** Purification of a ubiquitin protein peptidase from yeast with efficient in vitro assays. *J. Biol. Chem.* 264: 20331-20338. 1989.
49. **Loda, M., B. Cukor, S. W. Tam, P. Lavin, M. Fiorentino, G. F. Draetta, J. M. Jessup, and M. Pagano.** Increased proteasome-dependent degradation of the cyclin-dependent kinase inhibitor p27 in aggressive colorectal carcinomas. *Nat. Med.* 3: 231-234. 1997.
50. **Matsui, S. I., B. K. Seon, and A. A. Sandberg.** Disappearance of a structural chromatin protein A24 in mitosis: implications for molecular basis of chromatin condensation. *Proc. Natl. Acad. Sci. U. S. A.* 76: 6386-6390. 1979.
51. **Moazed, D. and D. Johnson.** A deubiquitinating enzyme interacts with SIR4 and regulates silencing in *S. cerevisiae*. *Cell* 86: 667-677. 1996.
52. **Mueller, R. D., H. Yasuda, C. L. Hatch, W. M. Bonner, and E. M. Bradbury.** Identification of ubiquitinated histones 2A and 2B in *Physarum polycephalum*. Disappearance of these proteins at metaphase and reappearance at anaphase. *J. Biol. Chem.* 260: 5147-5153. 1985.
53. **Murray, A. W., M. J. Solomon, and M. W. Kirschner.** The role of cyclin synthesis and degradation in the control of maturation promoting factor activity. *Nature* 339: 280-286. 1989.

54. **Nagarajan, L. and L. Narayana.** Transcriptional attenuation of PIM-1 gene. *Biochem. Biophys. Res. Commun.* 190: 435-439. 1993.
55. **Neuman, E., E. K. Flemington, W. R. Sellers, and W. G. Kaelin, Jr.** Transcription of the E2F-1 gene is rendered cell cycle dependent by E2F DNA-binding sites within its promoter. *Mol. Cell Biol.* 14: 6607-6615. 1994.
56. **Novina, C. D. and A. L. Roy.** Core promoters and transcriptional control. *Trends. Genet.* 12: 351-355. 1996.
57. **Olson, E. N.** MyoD family: a paradigm for development? *Genes Dev.* 4: 1454-1461. 1990.
58. **Pagano, M., S. W. Tam, A. M. Theodoras, P. Beer-Romero, G. Del Sal, V. Chau, P. R. Yew, G. F. Draetta, and M. Rolfe.** Role of the ubiquitin-proteasome pathway in regulating abundance of the cyclin-dependent kinase inhibitor p27. *Science* 269: 682-685. 1995.
59. **Papa, F. R. and M. Hochstrasser.** The yeast DOA4 gene encodes a deubiquitinating enzyme related to a product of the human tre-2 oncogene. *Nature* 366: 313-319. 1993.
60. **Pickart, C. M. and I. A. Rose.** Ubiquitin carboxyl-terminal hydrolase acts on ubiquitin carboxyl-terminal amides. *J. Biol. Chem.* 260: 7903-7910. 1985.
61. **Pizzuti, A., G. Novelli, A. Ratti, F. Amati, A. Mari, G. Calabrese, S. Nicolis, V. Silani, B. Marino, G. Scarlato, S. Ottolenghi, and B. Dallapiccola.** UFD1L, a developmentally expressed ubiquitination gene, is deleted in CATCH 22 syndrome. *Hum. Mol. Genet.* 6: 259-265. 1997.
62. **Ponting, C. P., Y. D. Cai, and P. Bork.** The breast cancer gene product TSG101: a regulator of ubiquitination? *J. Mol. Med.* 75: 467-469. 1997.
63. **Quandt, K., K. Frech, H. Karas, E. Wingender, and T. Werner.** MatInd and MatInspector: new fast and versatile tools for detection of consensus matches in nucleotide sequence data. *Nucleic. Acids. Res.* 23: 4878-4884. 1995.
64. **Reiss, Y., D. Kaim, and A. Hershko.** Specificity of binding of NH₂-terminal residue of proteins to ubiquitin- protein ligase. Use of amino acid derivatives to characterize specific binding sites. *J. Biol. Chem.* 263: 2693-2698. 1988.

65. **Riva, C., J. P. Lavieille, E. Reyt, E. Brambilla, J. Lunardi, and C. Brambilla.** Differential c-myc, c-jun, c-raf and p53 expression in squamous cell carcinoma of the head and neck: implication in drug and radioresistance. *Eur. J. Cancer B. Oral Oncol.* 31B: 384-391. 1995.
66. **Roest, H. P., J. van Klaveren, J. de Wit, C. G. van Gurp, M. H. Koken, M. Vermey, J. H. van Roijen, J. W. Hoogerbrugge, J. T. Vreeburg, W. M. Baarends, D. Bootsma, J. A. Grootegoed, and J. H. Hoeijmakers.** Inactivation of the HR23B ubiquitin-conjugating DNA repair enzyme in mice causes male sterility associated with chromatin modification. *Cell* 86: 799-810. 1996.
67. **Rogatsky, I., J. M. Trowbridge, and M. J. Garabedian.** Glucocorticoid receptor-mediated cell cycle arrest is achieved through distinct cell-specific transcriptional regulatory mechanisms. *Mol. Cell Biol.* 17: 3181-3193. 1997.
68. **Rusconi, S.** Transgenic regulation in laboratory animals. *Experientia* 47: 866-877. 1991.
69. **Rygaard, K., L. L. Vindelov, and M. Spang-Thomsen.** Expression of myc family oncoproteins in small-cell lung-cancer cell lines and xenografts. *Int. J. Cancer* 54: 144-152. 1993.
70. **Saltzman, A. G. and R. Weinmann.** Promoter specificity and modulation of RNA polymerase II transcription. *FASEB J.* 3: 1723-1733. 1989.
71. **Sambrook, J., E. F. Fritsch, and T. Maniatis.** *Molecular Cloning: A Laboratory Manual.* Anonymous New York: Cold Spring Harbour. 1989.
72. **Scheffner, M., J. M. Huibregtse, R. D. Vierstra, and P. M. Howley.** The HPV-16 E6 and E6-AP complex functions as a ubiquitin-protein ligase in the ubiquitination of p53. *Cell* 75: 495-505. 1993.
73. **Scherzinger, E., R. Lurz, M. Turmaine, L. Mangiarini, B. Hollenbach, R. Hasenbank, G. P. Bates, S. W. Davies, H. Lehrach, and E. E. Wanker.** Huntingtin-encoded polyglutamine expansions form amyloid-like protein aggregates in vitro and in vivo. *Cell* 90: 549-558. 1997.
74. **Shaeffer, J. R. and M. A. Kania.** Degradation of monoubiquitinated alpha-globin by 26S proteasomes. *Biochemistry* 34: 4015-4021. 1995.

75. **Smale, S. T.** Transcription initiation from TATA-less promoters within eukaryotic protein-coding genes. *Biochim. Biophys. Acta* 1351: 73-88. 1997.
76. **Stein, G. S., J. L. Stein, J. B. Lian, A. J. van Wijnen, and M. Montecino.** Functional interrelationships between nuclear structure and transcriptional control: contributions to regulation of cell cycle- and tissue-specific gene expression. *J. Cell Biochem.* 62: 198-209. 1996.
77. **Sun, Z., J. Pan, G. Bubley, and S. P. Balk.** Frequent abnormalities of TSG101 transcripts in human prostate cancer. *Oncogene* 15: 3121-3125. 1997.
78. **Swensen, J., M. Hoffman, M. H. Skolnick, and S. L. Neuhausen.** Identification of a 14 kb deletion involving the promoter region of BRCA1 in a breast cancer family. *Hum. Mol. Genet.* 6: 1513-1517. 1997.
79. **Swirnoff, A. H., E. D. Apel, J. Svaren, B. R. Sevetson, D. B. Zimonjic, N. C. Popescu, and J. Milbrandt.** Nabl, a corepressor of NGFI-A (Egr-1), contains an active transcriptional repression domain. *Mol. Cell Biol.* 18: 512-524. 1998.
80. **Templeton, A. R.** The theory of speciation via the founder principle. *Genetics* 94: 1011-1038. 1980.
81. **Tiao, G., M. Lieberman, J. E. Fischer, and P. O. Hasselgren.** Intracellular regulation of protein degradation during sepsis is different in fast- and slow-twitch muscle. *Am. J. Physiol.* 272: R849-56. 1997.
82. **van Nocker, S. and R. D. Vierstra.** Multiubiquitin chains linked through lysine 48 are abundant in vivo and are competent intermediates in the ubiquitin proteolytic pathway. *J. Biol. Chem.* 268: 24766-24773. 1993.
83. **Varshavsky, A.** The N-end rule: functions, mysteries, uses. *Proc. Natl. Acad. Sci. U. S. A.* 93: 12142-12149. 1996.
84. **Weintraub, S. J., K. N. Chow, R. X. Luo, S. H. Zhang, S. He, and D. C. Dean.** Mechanism of active transcriptional repression by the retinoblastoma protein. *Nature* 375: 812-815. 1995.
85. **Weintraub, S. J., C. A. Prater, and D. C. Dean.** Retinoblastoma protein switches the E2F site from positive to negative element. *Nature* 358: 259-261, 1992.

86. **Whyte, P., K. J. Buchkovich, J. M. Horowitz, S. H. Friend, M. Raybuck, R. A. Weinberg, and E. Harlow.** Association between an oncogene and an anti-oncogene: the adenovirus E1A proteins bind to the retinoblastoma gene product. *Nature* 334: 124-129. 1988.
87. **Wilkinson, K. D.** Ubiquitin carboxyl-terminal hydrolase. In: *A Handbook of Proteolytic enzymes*. edited by A. Barret and N. Rawlings. Academic Press. 1997.
88. **Wilkinson, K. D., K. M. Lee, S. Deshpande, P. Duerksen-Hughes, J. M. Boss, and J. Pohl.** The neuron-specific protein PGP 9.5 is a ubiquitin carboxyl-terminal hydrolase. *Science* 246: 670-673. 1989.
89. **Wilkinson, K. D., V. L. Tashayev, L. B. O'Connor, C. N. Larsen, E. Kasperek, and C. M. Pickart.** Metabolism of the polyubiquitin degradation signal: structure, mechanism, and role of isopeptidase T. *Biochemistry* 34: 14535-14546. 1995.
90. **Wilson, P. O., P. C. Barber, Q. A. Hamid, B. F. Power, A. P. Dhillon, J. Rode, I. N. Day, R. J. Thompson, and J. M. Polak.** The immunolocalization of protein gene product 9.5 using rabbit polyclonal and mouse monoclonal antibodies. *Br. J. Exp. Pathol.* 69: 91-104. 1988.
91. **Wing, S. S., N. Bedard, C. Morales, P. Hingamp, and J. Trasler.** A novel rat homolog of the *Saccharomyces cerevisiae* ubiquitin-conjugating enzymes UBC4 and UBC5 with distinct biochemical features is induced during spermatogenesis. *Mol. Cell Biol.* 16: 4064-4072. 1996.
92. **Wyllie, A. H., K. A. Rose, R. G. Morris, C. M. Steel, E. Foster, and D. A. Spandidos.** Rodent fibroblast tumours expressing human myc and ras genes: growth, metastasis and endogenous oncogene expression. *Br. J. Cancer* 56: 251-259. 1987.
93. **Xu, G., D. M. Livingston, and W. Krek.** Multiple members of the E2F transcription factor family are the products of oncogenes. *Proc. Natl. Acad. Sci. U. S. A.* 92: 1357-1361. 1995.
94. **Yamasaki, L., T. Jacks, R. Bronson, E. Goillot, E. Harlow, and N. J. Dyson.** Tumor induction and tissue atrophy in mice lacking E2F-1. *Cell* 85: 537-548. 1996.

95. **Yarden, Y., J. A. Escobedo, W. J. Kuang, T. L. Yang-Feng, T. O. Daniel, P. M. Tremble, E. Y. Chen, M. E. Ando, R. N. Harkins, and U. Francke.** Structure of the receptor for platelet-derived growth factor helps define a family of closely related growth factor receptors. *Nature* 323: 226-232. 1986.
96. **Zhu, Y., M. Carroll, F. R. Papa, M. Hochstrasser, and A. D. D'Andrea.** DUB-1, a deubiquitinating enzyme with growth-suppressing activity. *Proc. Natl. Acad. Sci. U. S. A.* 93: 3275-3279. 1996.

IMAGE EVALUATION TEST TARGET (QA-3)

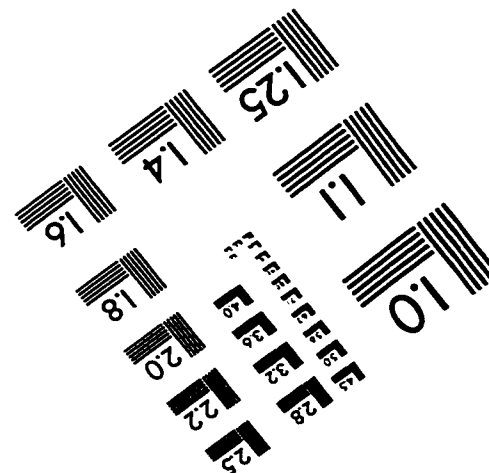
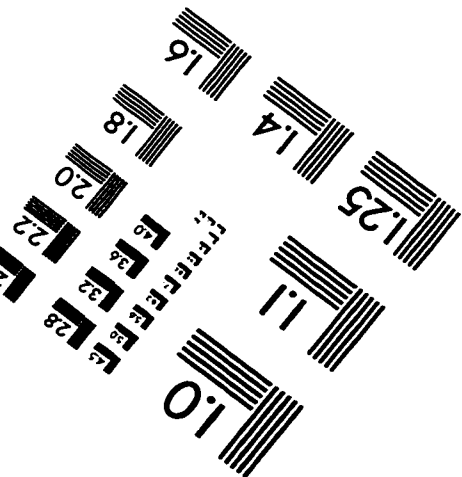
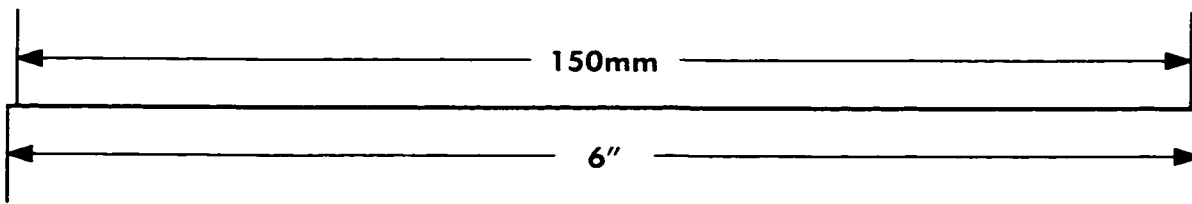
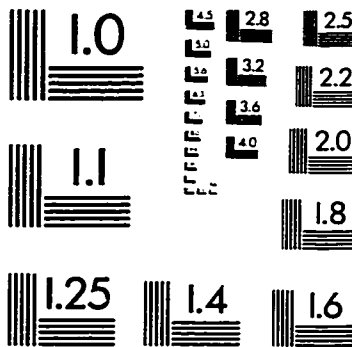
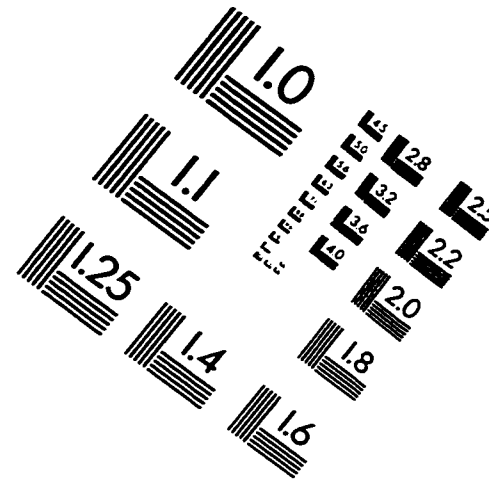
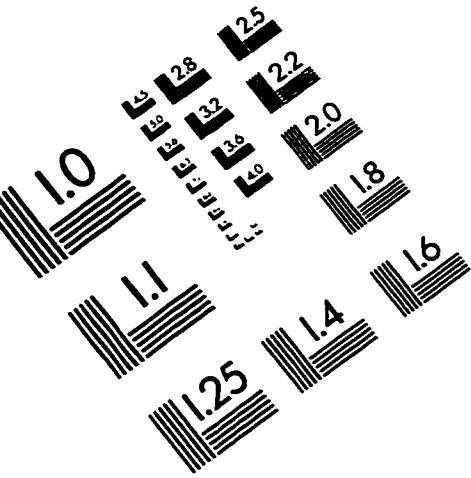

APPLIED IMAGE, Inc
1653 East Main Street
Rochester, NY 14609 USA
Phone: 716/482-0300
Fax: 716/288-5989

© 1993, Applied Image, Inc., All Rights Reserved