

University of Ottawa
Faculty of Graduate and Postdoctoral Studies
M.Sc. Systems Science

Emergency Preparedness and Response Planning:
A Value-Based Approach to Preparing Coastal Communities for
Sea Level Rise

Thesis submitted to the
Faculty of Graduate and Postdoctoral Studies
in partial fulfillment of the requirements for the
Master of Science degree in Systems Science

Alexander Quoc Huy Chung

Thesis Supervisor: Dr. Daniel Lane
Co-supervisor: Dr. Colleen Mercer Clarke
Telfer School of Management
University of Ottawa

Abstract

Extreme weather events have become a common occurrence and coastal communities are adversely affected by it. Studies have shown that the changing climate has increased the frequency and severity of storms, surging sea levels, and floods, as was seen with Hurricane Sandy (2012) and Typhoon Haiyan (2013). The need to be proactive in preparing for these events, as a means of climate change adaptation and disaster risk reduction, is evident. This study focuses on the formal definition, measurement and simulation of coastal community preparedness and response to severe storm events. Preparedness and response requires resources, emergency plans, informed decision making and the ability to cope with unexpected events. A suite of preparedness indicators is developed using a three level hierarchical framework in the construction of a coastal community preparedness index to evaluate resources and plans. Informed decision making for emergency management personnel in the Emergency Operations Centre (EOC) is evaluated through a table-top exercise using a five-phase approach. Lastly, decision making with risk is introduced with a storm decision making simulation model. This study is applied to the case of the breakwater failure in the coastal community of Little Anse, Cape Breton, Nova Scotia.

Keywords: climate change adaptation, disaster risk reduction, emergency preparedness and response, decision analysis, community adaptation, adaptive strategies, simulation, table-top exercises

Acknowledgements

First and foremost, I would like to thank my supervisors, Dr. Daniel Lane and Dr. Colleen Mercer Clarke. I am grateful for their support, guidance, encouragement and feedback throughout my studies. This would not have been possible without them and their extreme dedications. They have helped me become a better researcher, writer and person and I will forever be indebted to them for that.

I would like to express my great appreciation to Kathy Cunningham and the entire C-Change Team. It was a privilege to have worked with such wonderful people and they have made the process so much more enjoyable.

My gratitude is extended to Dr. Craig Kuziemsky and Dr. Tracey O'Sullivan, my thesis examiners, for their insightful recommendations. The time they have put into reviewing my work and challenging me is invaluable.

I am particularly grateful for the assistance given by Mona O'Brien from the Canadian Red Cross for her help in the construction and facilitation of the table-top exercise. It was an honour to be able to deliver the table-top exercise to the community of Isle Madame with her assistance.

I would also like to extend my thanks to Kathy Branton from York University for giving me an opportunity to attend the Emergency Management Ontario course. The course has proven to be a valuable experience in my studies and work.

Last but not least, I would like to express my deepest gratitude to my family and friends. Without their support I would not be where I am today and none of this would be possible.

Abbreviations

The following section itemizes common abbreviations found in the writing of this thesis document. A glossary of common terms can be found on page 168.

ADMS	Advanced Disaster Management Simulator
AHP	Analytic Hierarchy Process
CARICOM	Caribbean Community
CERT	Community Emergency Response Team
CUSERT	Carleton University Student Emergency Response Team
DPI	Disaster Preparedness Index
EHS	Emergency Health Services
EMBC	Emergency Management British Columbia
EMO	Emergency Management Organization / Emergency Measures Organization
EMWIN	Emergency Managers Weather Information Network
EOC	Emergency Operations Centre
ESRI	Environmental Systems Research Institute
FERP	Federal Emergency Response Plan
FEMA	Federal Emergency Management Agency
GEM	Global Environmental Multiscale
HFA	Hyogo Framework for Action
IEMAC	International Emergency Management Assistance Compact
IEMG	International Emergency Management Group
IEMS	Integrated Emergency Management System
IFRC	International Federation of Red Cross and Red Crescent
IPCC	Intergovernmental Panel on Climate Change
JEOC	Joint Emergency Operations Centre
LIDAR	Laser Imaging Detection and Ranging
MCR	Municipality of the County of Richmond
MEOPAR	Marine Environmental Observation Prediction and Response
MEOW	Maximum Envelopes of Water
MOM	Maximum of the MEOW
NGO	Non-Governmental Organization
NOAA	National Oceanic and Atmospheric Administration
NWS	National Weather Service
SLOSH	Sea, Lake, and Overland Surges from Hurricanes
SD	Standard Deviation
TCL	Target Capabilities List
UN/ISDR	United Nations International Strategy for Disaster Reduction
UN/OCHA	United Nations Office for the Coordination of Humanitarian Affairs
UTL	Universal Task List

Table of Contents

Abstract.....	2
Acknowledgements.....	3
Abbreviations.....	4
List of Tables.....	7
List of Figures.....	9
1 Introduction.....	11
1.1 Background and Motivation.....	11
1.2 Research Questions and Objectives.....	13
1.3 Thesis Outline.....	15
2 Literature Review.....	17
2.1 Terminology.....	17
2.2 Approaches to Preparedness.....	18
2.3 Preparedness Measures.....	37
2.4 Evaluation and Preparedness Modelling.....	43
2.5 Applications.....	51
2.6 Summary.....	61
3 Methodology.....	63
3.1 Defining the Components of Preparedness and Response.....	64
3.2 Indicators of Preparedness Specific to Coastal Communities.....	65
3.3 Table-Top Exercises.....	70
3.4 Process Definition and Dynamics with Uncertainty.....	72
3.5 Process Simulation.....	74
3.6 Summary.....	75
4 Indicators of Emergency Preparedness.....	77
4.1 Dimension 1 - Communication and Collaboration.....	84
4.2 Dimension 2 - Monitoring and Forecasting.....	90

4.3	Dimension 3 - Training, Education and Community Awareness.....	97
4.4	Dimension 4 - Emergency Services and Operations	101
4.5	Dimension 5 - Local Governance and Social Services	104
5	Emergency Response Table-Top Exercise and Analysis	109
5.1	Table-Top Exercise Design.....	109
5.2	Phased Table-Top Exercise Facilitation Guide	111
5.3	Table-Top Exercise Critical Analysis	124
6	Emergency Response Simulation Framework.....	132
6.1	Structured Decision Making with Uncontrollable Events	132
6.2	Decision Making Under Risk.....	133
6.3	<i>Arena</i> Simulation Model Analysis	142
7	Conclusions and Recommendations	149
7.1	Conclusion	149
7.2	Recommendations for Further Study.....	151
7.3	Future Research in Climate Change Adaptation and Disaster Risk Reduction	153
	Bibliography	155
	Glossary of Terms	168
Appendix A	Indicator Score Analysis	169
Appendix B	Community Preparedness Questionnaire Form	179
Appendix C	Community Preparedness Questionnaire Results	184
Appendix D	Presentation Slides for Table-Top Exercise Facilitation	185
Appendix E	Detailed Event Decision Trees	192
Appendix F	<i>Arena</i> Simulation Model	201
Appendix G	<i>Arena</i> Simulation Model Output Summary.....	210

List of Tables

Table 2-1 StormReady population-based guidelines overview. Source: NOAA (2013).....	21
Table 2-2 Jurisdictions participating in the IEMAC. Source: IEMG (2013).....	36
Table 3-1 Classification table for the characteristics of preparedness as defined by the approaches and frameworks literature	67
Table 3-2 Preference scale for AHP pair-wise comparisons. Source: Stevenson (2010).....	69
Table 4-1 Classification of the 12 numbered preparedness approaches reviewed into categories based on their scope and objectives	79
Table 4-2 Hierarchy of emergency preparedness.....	82
Table 4-3 Early warning systems checklist for Hong Kong, CN.....	86
Table 4-4 Public information management indicator score for Victoria, CA	87
Table 4-5 Populations at risk indicator score table for New York City, US.....	88
Table 4-6 Score assignment for community collaborative networking indicators.....	89
Table 4-7 Weather forecasting means indicator score for the community of Bangued, PH	93
Table 4-8 Trained public spotters indicator score assignment for Ontario, CA	94
Table 4-9 GIS flood mapping and simulation analysis indicator score assignment for the community of Galveston, US	96
Table 4-10 Simulation exercise indicator score assignment for the community of Little Anse, CA	97
Table 4-11 Indicator score assignment for emergency response plans of a hypothetical community	98
Table 4-12 Household preparedness indicator score assignment for a hypothetical community	99
Table 4-13 Public outreach indicator score assignment for New Orleans, US.....	100
Table 5-1 Phases of the table-top exercise and description of detailed events	115
Table 6-1 Summary of the decision tree models for the nine detailed events. A description is provided with the decision alternatives, state probabilities and outcomes.....	136

Table 6-2 Summary of mean outcome values for the four response decision strategies tested.

..... 144

List of Figures

Figure 2-1 FEMA's Target Capabilities List overview. Source: FEMA (2007b)	24
Figure 2-2 The incident command system's P-model. Source: FEMA (2012).....	33
Figure 2-3 IEMAC activation process. Source: IEMG (2013).....	37
Figure 2-4 Disaster index measurement model diagram. Source: Simpson and Katirai (2006)...	41
Figure 2-5 Example fault tree for the analysis of identifying risks to evacuation reliability. Source: Jackson (2008).....	43
Figure 2-6 Sample output of the SLOSH model for Hurricane Ike in 2008 in Galveston Bay, Texas. Source: NOAA (2012a)	45
Figure 2-7 UN-ISDR Stop Disasters simulation game screenshot Source: UN/ISDR (2007)	48
Figure 2-8 Hierarchical structure for emergency management responsibilities in Canada	54
Figure 2-9 Governance structure of emergency management in Canada	57
Figure 2-10 Map of Charlottetown, Prince Edward Island. Source: Google Maps (2014)	58
Figure 2-11 Map of Isle Madame, Nova Scotia. Source: Google Maps (2014).....	60
Figure 3-1 The components of emergency preparedness and response and how they will be addressed.....	65
Figure 3-2 Sample preparedness hierarchy showing the three levels: dimensions, attributes, and indicators	68
Figure 3-3 Emergency Management Ontario's phases of table-top exercise design and implementation. Source: Emergency Management Ontario (2009).....	71
Figure 3-4 Sample decision tree structure with arbitrary values for the state probabilities and outcomes. Source: Stevenson (2010)	72
Figure 3-5 Decision tree framework applied to decision making in the EOC during storm events	73
Figure 4-1 Mobile phone screenshot of the University of Ottawa's uOttawa Alert System.....	79
Figure 4-2 Hierarchy showing the weights derived from a pair-wise comparison for the dimensions, attributes and indicators of preparedness.....	83

Figure 4-3 Tsunami warning sign at Grand Anse Beach, Grenada. Source: Chung (2013).....	95
Figure 5-1 Satellite bird's eye view of Little Anse, N.S. View looking south. (Bing Maps, 2013)	113
Figure 5-2 Screenshot of the exercise's Environment Canada's weather warning. (edited: Environment Canada, 2014)	116
Figure 5-3 Satellite map of Little Anse, N.S. (Bing Maps, 2014)	118
Figure 6-1 Decision path based on the expected value approach calculated from the decision trees	145
Figure 6-2 Mean utility and percentage values for each event based on a random decision making strategy.....	145
Figure 6-3 Decision path based on an intra-community decision making strategy	146
Figure 6-4 Decision path based on a extra-community decision making strategy.....	147
Figure 7-1 The components of emergency preparedness and response, and what this study has done to address each component	150

1 Introduction

Climate change is one of the great environmental challenges of our time. There is increasing discussion and evidence from the scientific community that the climate is changing at an unprecedented rate at a global scale. Associated with climate change is the potential for an increase in occurrence of severe storms that may have adverse effects on humans. The need to adapt to these changes and be prepared for severe environmental events is crucial.

This introductory chapter of the thesis document, in partial fulfillment of the Master's degree in Systems Science, presents the issues of climate change and the importance of developing adaptation methods, primarily in the area of preparing for the effects of sea level rise. Research questions and objectives are presented in the latter section of this chapter.

1.1 Background and Motivation

In 2013, the Intergovernmental Panel on Climate Change (IPCC) released the first of three parts for the Fifth Assessment Report. The contributions from Working Group I: The Physical Science Basis states that it is "certain" that the global mean surface temperature has increased since the late 19th century. Each decade of the past thirty years, has been successively warmer than the previous. The report also confirms that it is "virtually certain" that the frequency and intensity of storms have increased in the North Atlantic (IPCC, 2013).

Climate change is a trending topic of discussion for scientists and policy makers. Scientists are in agreement that even under the most optimistic conditions, the earth has committed to some degree of warming for the near future and the need for humans to adapt is imperative (Etkin et al., 2012; World Bank, 2008). This raises the question of what a changing climate brings in terms of a new environment and how communities can anticipate and prepare for these changes.

As the temperature rises, evaporation rates will also increase, adding more moisture into the atmosphere. A likely result of increased atmospheric vapour is an increase in more drastic and unpredictable weather occurrences. Rising sea levels are also consistent with

warming temperatures due to the thermal expansion of seawater, and increased water volume contributed by the melting of glaciers, ice caps and ice sheets. The global average sea level has risen at an average rate of 3.1 mm/yr since 1993, which exceeds modelled projections (IPCC, 2007). The presumed consequences of sea level rise are increased storm surge occurrences as well as more severe weather phenomena as seen with Hurricane Katrina (August 2005) and Hurricane Sandy (October 2012). Changes in precipitation patterns and rising sea level put coastal communities first in line to witness the effects of climate change.

The notion of preparedness for natural disasters can be a contentious topic of discussion for policy makers. To date, it has garnered little attention in policy making, where more immediate problems attain greater priority (Jackson, 2008). Investing in preparedness for a situation that may or may not occur may seem unnecessary, but with the evidence pointing towards a rapidly changing climate, preparedness cannot be overlooked. Decision and policy makers are generally reactive, taking recourse action after the storm has occurred. Learning from mistakes based on real life situations is important, but with the tools and technology currently available, decision-makers have the ability to also be proactive. Not only will proactive assessment aid decision and policy makers, it will also allow the public to set reasonable expectations of their government at all levels and invoke a sense of confidence and comfort in the general population (Jackson, 2008).

Preparedness, as defined by the United Nations International Strategy for Disaster Risk Reduction, is any pre-disaster activities undertaken to enhance a community's ability to respond to and cope with storm situations (UN/ISDR & UN/OCHA, 2008). As defined in detail in Chapter 3, preparedness in the context of this study refers to the concept of having a plan in place, the resources to carry out response activities, informed decision making, and having the ability to manage uncontrollable events. The concepts of decision analysis and management of uncontrollable events are often neglected from formal definitions of what it means to be prepared.

This research is an integral component of and is supported by the C-Change Project - Managing Adaptation to Environmental Change in Coastal Communities: Canada and the Caribbean. The C-Change project is an International Community-University Research Alliance (ICURA) that aims at enhancing the capacity of coastal communities to anticipate and to adapt to environmental change, such as the effects of rising sea levels and more severe weather events. The partner coastal communities selected include four communities in Canada, as well as four from the Caribbean. Selection criteria include anticipated serious and immediate threats to infrastructure should an environmental disaster occur (C-Change, 2011c).

Within the C-Change project, the work conducted as part of this thesis is at the community engagement and practical implementation level. This study builds on previous work conducted in the communities that include: community spatial models, econometric and socioeconomic impact models, and vulnerability and risk modelling (C-Change, 2011c). The community profile created from these studies paved the way for the development of a training tool or evaluation framework presented in this thesis. Building on the research to date, this study examines the state of preparedness and response for coastal communities within the C-Change Project. The following research questions and objectives are proposed.

1.2 Research Questions and Objectives

Sea level rise is likely to increase the threat of storm surges in coastal environments. Storm surges can inundate low lying infrastructure and community assets. The challenge in designing adaptive response strategies lies in balancing between being cost efficient and being sufficiently prepared. The notion of preparedness can be, to some extent, dependent on the magnitude of the storm event; a challenge because of the uncertainty with predicting weather.

It is commonly seen that preparedness planning is done retrospectively - gaps in response strategies are identified and addressed post-storm if addressed at all. A report released in 2008 from the Canadian Standing Senate Committee on National Security and Defence states that "Canadians have no assurance that essential government operations will function during emergencies" (Canada Senate, 2008). The same results are found in the 2009

Fall Report of the Auditor General of Canada for Emergency Management - Public Safety Canada where the first point of the summary states “Public Safety Canada has not exercised the leadership necessary to coordinate emergency management activities, including critical infrastructure protection in Canada” (Canada Office of the Auditor General, 2009).

This research project aims at developing a framework to define preparedness and response for storm surges in coastal communities and to develop methods to assess the benefits and gaps associated with existing response strategies pre-storm event.

The following research questions are addressed in this study:

1. What does it mean for communities to be prepared for emergency situations?
2. How can this concept of preparedness be applied to coastal communities that are vulnerable to sea level rise and more frequent severe storms?
3. Is the existing emergency response system effective and reliable, i.e., are there gaps and/or shortcomings?
4. What actions are required to improve preparedness and response?

The objective of this research is to develop a framework for coastal communities to assess their level of preparedness and response in the event of a severe storm, and to present mechanisms for enhancing community preparedness. Emergency management often encompasses four phases: prevention, preparedness, response and recovery (Public Safety Canada, 2013). However, it should be noted that this study focuses on the preparedness and response phases. By addressing the response operation we are inherently enhancing preparedness.

Several steps are taken to achieve the objectives of this study and provide a means of answering the research questions. These steps consist of:

1. Examining literature to determine what it means to be prepared for emergency situations.

2. Developing hierarchal indicators of preparedness in order to apply concepts of preparedness to coastal communities vulnerable to the effects of sea level rise.
3. Constructing an exercise designed to evaluate the decision making aspect of the emergency response system for communities.
4. Analyzing the results of the community's response to a simulated storm event to identify aspects of preparedness and response that need improvement.

Given recent events, e.g., Hurricane Sandy (2012) and Typhoon Haiyan (2013), many efforts have been made to assess overall preparedness and create a baseline standard that defines preparedness. However, many of these standards only examine the layout and framework for emergency planning. They typically do not include a method of evaluation for deployment and effectiveness of the system in practice. A review of current approaches to defining preparedness and their shortcomings is presented in Chapter 2. A quantitative modelling approach to determine preparedness provides the missing link in the adoption of community-based storm surge adaptation strategies. Communities would be able to utilize the table-top model described in this thesis to identify gaps in their adaptive response strategy and improve upon them.

1.3 Thesis Outline

This study is organized in the following manner:

Chapter 1 – Introduction: The current section provides the background information to climate change as well as the motivation for this study. Several key issues stemming from climate change were discussed and the need for adaptation was shown. The latter section of Chapter 1 presented the challenges in designing adaptive response strategies. This led to the research questions and objectives of the study.

Chapter 2 – Literature Review: A literature review of the concepts examined in this study is presented in this section. Areas of interest include terminologies, approaches to preparedness and response, preparedness measures and indicators, and preparedness and

response modelling. Chapter 2 also presents applications of the study and a summary of the literature reviewed.

Chapter 3 – Methodology: The methodology section of the thesis examines the tools and potential methods required to develop the framework mentioned as part of the objectives. Preparedness and response are defined within the context of coastal communities vulnerable to the effects of severe storms. A process for the storm table-top exercise is laid out and suggested as a means for identifying gaps in response plans.

Chapter 4 – Indicators of Emergency Preparedness: This chapter presents the hierarchical indicators of preparedness developed for coastal communities vulnerable to the effects of sea level rise. The indicators are discussed and examples are presented. A discussion on the derived weights and index of preparedness can also be found in this chapter.

Chapter 5 – Emergency Response Table-Top Exercise and Analysis: This chapter focuses on the decision making aspect by employing the use of table-top exercises. A framework for designing a table-top exercise is provided. The framework is followed by the application of the table-top to the case of the breakwater failure in the community of Little Anse, Isle Madame, Nova Scotia. A critical analysis of the table-top concludes the chapter.

Chapter 6 – Emergency Response Simulation Framework: A framework for a simulation model is provided in this chapter. The framework evaluates decision making in the Emergency Operations Centre given uncontrollable events that may affect the response operation. Topics of discussion include decision making under risk and a discrete event process simulation.

Chapter 7 – Conclusions and Recommendations for Further Study: A summary of the findings and conclusions can be found in this chapter. Topics of further research to build on this study are also discussed.

2 Literature Review

Weather patterns of late have encouraged many communities to review their emergency preparedness and response strategies in addition to the resources they have to respond to storms. The strategy reviews put policy makers from all ends of the spectrum in a position to determine at what point one can say that they have achieved preparedness. In Chapter 2, we wish to frame the issues behind preparedness and response for emergency situations in communities. Several key concepts found in literature are examined along with the different methods in use to define preparedness.

The fields of coastal and environmental management, among many others, carry recognized knowledge from the academic body as well as governments and non-government organizations (NGO). This study reviews both published and grey literature (unpublished government and NGO reports that have been distributed). Though many of the approaches from grey literature have not been fully evaluated, they are widely accepted internationally as acceptable frameworks. Grey literature serves as a valuable tool in the fields of planning and management. For example, the Hyogo Framework for Action has been accepted internationally as a standard for disaster risk reduction (UN/ISDR, 2005).

To set the stage for the literature review, common terminologies used in the field are presented in Section 2.1. The terminologies are followed by approaches to preparedness as defined by different levels of disaster management organizations in Section 2.2. Numerous attempts have been made to quantify preparedness in the form of a measure or index. These are discussed in Section 2.3. Methods to model storm surge effects and response efforts are shown in Section 2.4. An overview of the applications for Canadian Communities and a profile of Charlottetown, P.E. and Isle Madame, N.S., are shown in Section 2.5.

2.1 Terminology

Terminologies used in the community preparedness and response field of study can be ambiguous or interchangeable due to the range of community based programs that exist. The

following section identifies key terms and defines those terms that are fundamental to this research.

The term *adaptation* used in climate change literature has its roots in the field of natural science and specifically in the discipline of evolutionary biology (Smit & Wandel, 2006). Classically, *adaptation* refers to “the evolutionary process involving a genetic or behavioural change in which a population or individual becomes fitted to its prevailing environment” (Reece et al., 2011). The C-Change project defines adaptation as the capacity of natural and human systems to adjust to global and local environmental change and to reduce adverse effects (C-Change, 2011c). The definition of *adaptation* as defined by C-Change is applied in this study.

The term *disaster* is commonly used in emergency management. It may refer to a wide variety of disaster types, ranging from human induced (e.g., terrorist and cyber-attacks) to naturally occurring (e.g., floods and earthquakes) disasters (FEMA, 2007b). The Intergovernmental Panel on Climate Change defines *disasters* as “severe alterations in the normal function of a community due to hazardous physical events, leading to widespread adverse human, material, economic, or environmental effects requiring immediate emergency response” (IPCC, 2012). Within the context of this study, disasters are events caused by sea level rise, storm surges and severe weather.

Approaches to defining preparedness are examined in the following section (Section 2.2). Each approach presents a different perspective and method for defining preparedness. The approaches to defining preparedness in the following section paves the way for the definition of preparedness employed for this study. Preparedness in the context of this study refers to having the resources and response plans necessary, the ability to make informed decisions during the storm event, as well as the ability to manage uncontrollable events. The concept of preparedness is further discussed in Section 3.1.

2.2 Approaches to Preparedness

Organizations worldwide have taken a proactive approach to developing definitions of preparedness. These approaches range in scope and size from local community based programs

(provincial or territorial Emergency Measures Organization) to international efforts (Hyogo Framework for Action). Local community based programs focus on resources specific to the community at risk while international efforts aim at introducing a holistic approach to defining preparedness worldwide.

An overview of the different scopes of preparedness as defined by those in the field would provide a better understanding of what it means to be prepared. In the following section, five different approaches to preparedness are examined: (1) National Weather Service's StormReady Program, (2) Federal Emergency Management Agency's Target Capabilities List, (3) the United Nations Office for Disaster Risk Reduction (UN/ISDR)'s Hyogo Framework for Action, (4) Public Safety Canada's Emergency Measures Organizations, and (5) the International Emergency Management Group's International Emergency Management Assistance Compact. Each organization has similar objectives but differ in their approach as well as in their terminologies. The terminology used in each section is within the context presented by that specific organization's approach.

2.2.1 US National Weather Service – StormReady Program

The StormReady program introduced in 1999 by the National Weather Service (NWS) has, as of March 31st 2013, certified 2056 communities in the United States to be "StormReady" (NOAA, 2013). The National Weather Service is a branch of the National Oceanic and Atmospheric Administration (NOAA). The StormReady program has the objective of increasing the level of preparedness in the community through a checklist approach that aims at improving the communication and safety skills needed to mitigate storm effects, before and during a storm. The program as described by NWS intends to (NOAA, 2004):

1. Improve on effectiveness of weather warnings
2. Provide recommendations for local emergency personnel to improve hazardous weather operations
3. Help community leaders justify budget allocations for emergency preparedness
4. Reward communities that have exemplified what it means to be "StormReady"

5. Improve the community's position in the National Flood Insurance Program

Aside from improving community response, the designation is likely to increase property values in the community. From a public relations standpoint, this provides an incentive that encourages all citizens to participate.

A set of guidelines was developed to encourage communities to take a proactive approach and improve their response operations. The guidelines touch on the different aspects or dimensions of being prepared as defined by the NWS. They are communication, information reception, hydro-meteorological monitoring, warning dissemination, community preparedness and administration (NOAA, 2013). Table 2-1 shows an overview of the population based guidelines developed for the StormReady program. Guidelines that have boxes containing an (X) are required at that given population as shown in the table, while empty boxes mean that the guidelines are not required for a population of that size. In cases where the guidelines require a quantitative count, they are presented in the table as a numerical value. Community budgets are typically dependent of the community size, therefore the guidelines were designed to accommodate budgets and resources available based on the population size (NOAA, 2004).

To meet the communication guideline as set out by the StormReady program, a warning point that can relay NWS information must be established as well as an Emergency Operations Centre (EOC) in communities with a population larger than 2,500 (NOAA, 2004). This communication point can be established at law enforcement or fire department dispatching points. In the case where a community has neither of these, the use of a county agency is also acceptable. The office must operate 24 hours a day with warning reception capabilities and authority to activate local warning systems. In larger communities, an EOC is required and must be staffed during hazardous weather. Aside from the duties of a warning point, the EOC must also be able to communicate with adjacent communities and act as the messenger between the NWS and community decision-makers (NOAA, 2004).

The second guideline for the StormReady program is the number of ways in which the warning point or EOC can receive NWS warnings. The storm may damage communication

means, therefore it is important to have several different means of communication with the NWS. These information receivers range from something as technologically advanced as Emergency Managers Weather Information Network (EMWIN) receivers with satellite feed to something as basic as a radio or pager system (NOAA, 2004).

Aside from communication and emergency operations centres, communities must also be able to monitor hydro-meteorological (weather) information in their surroundings. StormReady suggests the following means of gathering supplementary weather information: access to radar information via internet, instruments to measure local hydrological conditions, or locally owned and operated weather radars (NOAA, 2004).

Table 2-1 StormReady population-based guidelines overview. Source: NOAA (2013)

Guidelines	Population			
	< 2,500	2,500 – 14,999	15,000 – 40,000	> 40,000
1. Communication				
Established 24 hr Warning Point	X	X	X	X
Establish Emergency Operations Centre		X	X	X
2. NWS Information Reception				
Number of ways for EOC/WP to receive NWS warning, etc.	3	4	4	4
3. Hydrometeorological Monitoring				
Number of ways to monitor hydrometeorological data	1	2	3	4
4. Local Warning Dissemination				
Number of ways for EOC/WP to disseminate warnings	1	2	3	4
NWR - SAME receivers in public facilities	X	X	X	X
5. Community Preparedness				
Number of annual weather safety talks	1	2	3	4
Train spotters and dispatchers biennially	X	X	X	X
Host/co-host annual NWS spotter training				X
6. Administrative				
Formal hazardous weather operations plan	X	X	X	X
Biennial visits by emergency manager to NWS	X	X	X	X
Annual visits by NWS official to community	X	X	X	X

Communication with the NWS and surrounding communities is important, but the EOC and warning points are the middle connection in the communication chain. The ultimate goal

lies in relaying the information to decision-makers and the public. For this reason warning dissemination methods should be placed to alert and inform the public. The StormReady program proposes several public propagation means such as television audio/video overrides, outdoor warning sirens and the NOAA Weather Radio All-hazards receivers (NOAA, 2004)

From a different perspective, the last two guidelines are aimed at pre-storm preparation practices. Public education is vital in preparing citizens to respond effectively to weather threats. A more informed community is more likely to take proactive steps to receive warnings and recognize potential threatening weather conditions (NOAA, 2004). The three subcomponents of the community preparedness guideline for the StormReady checklist are: to conduct safety talks for schools, hospitals and industries, facilitate weather related safety campaigns, and send EOC staff to NWS storm spotter training (NOAA, 2004). Lastly, no program is successful without proper administration for support. The administrative team has to be well organized and be able to effectively communicate with NWS (NOAA, 2004).

The StormReady program was proven to be effective in the case of Dickinson County Iowa on July 17th 2010. Dickinson County encountered a severe windstorm that caused widespread damage across most of the Great Lakes area of Dickinson County in Northwest Iowa (NOAA, 2010). Wind gusts of 100 mph (160.93 kph) damaged trees, boats, farm buildings and storage sheds. Numerous residents reported hearing the warnings and took shelter before the storm hit and credited the National Weather Service in issuing the life-saving warnings (NOAA, 2010).

2.2.2 US Federal Emergency Management Agency – Target Capabilities List

In an effort to be better prepared for emergency situations in the United States, the Department of Homeland Security's Federal Emergency Management Agency (FEMA) set out to establish a national policy to prevent, protect, respond, and recover from terrorist attacks, major disasters, and other emergencies. The National Preparedness Guidelines were created in 2007 to establish the definition of preparedness in the United States. The guidelines provide

priorities and target capabilities for Americans to achieve (FEMA, 2007a). The vision for the guidelines was coined as the following (FEMA, 2007a, p. 1):

“A nation prepared with coordinated capabilities to prevent, protect against, respond to, and recover from all-hazards in a way that balances risk with resources and need.”

The planning process as outlined by the National Preparedness Guidelines is supported by three planning tools; the National Planning Scenarios, Target Capabilities List (TCL), and Universal Task List (UTL) (FEMA, 2007a)

The National Planning Scenarios portray a diverse set of 15 high-threat scenarios that covers a range of possible situations, including terrorist attacks and natural disasters. Collectively they were designed to focus on contingency planning at all levels from governments to the private sector and the public (United States, Department of Homeland Security, 2006). The scenarios were used for identifying tasks required to facilitate efforts in preparing for emergency situations as well as the capabilities required to perform the tasks. A catalogue of these tasks can be found in the UTL (United States, Department of Homeland Security, 2005), while a listing of capabilities is found in the TCL (FEMA, 2007b).

The TCL contains 37 capabilities that are shown in Figure 2-1. They address the four homeland security mission areas of prevent, protect, respond, and recover. The TCL document also acts as a basis for assessing preparedness in local communities, an important tool in designing action plans. The approach to defining these capabilities rests on three fundamental questions (FEMA, 2007b):

1. How prepared do we need to be?
2. How prepared are we?
3. How do we prioritize efforts to close the difference?



Figure 2-1 FEMA's Target Capabilities List overview. Source: FEMA (2007b)

To answer these questions, a threat analysis was conducted using the 15 National Planning Scenarios. Tasks required to overcome these scenarios were identified and capabilities necessary to perform the tasks were compiled as the TCL (FEMA, 2007b).

Each capability summary in the TCL document contains the capability definition and is followed by an outcome statement that describes the expected results to be achieved. The summary includes an identification of the relationship between the capability and the emergency support function. Each summary also contains a description of major activities performed and the critical tasks and measures associated with the each activity. As a method to determine if a community has achieved the target capability, the summary provides metrics associated with the performance measures of that capability (FEMA, 2007b).

Performance measures are quantitative or qualitative levels against which achievements of a task or capability can be assessed. It should be noted that they are not normalized, nor are they standards. They are simply a guide for planning and training.

The communication capability is used as an example of the information provided by the TCL document. The capability definition is given as follows (FEMA, 2007b, p. 29):

“Communications is the fundamental capability within disciplines and jurisdictions that practitioners need to perform the most routine and basic elements of their job functions. Agencies must be operable, meaning they must have sufficient wireless communications to meet their everyday internal and emergency communication requirements before they place value on being interoperable, i.e., able to work with other agencies.”

An example of critical tasks required to meet this capability are (FEMA, 2007b, p. 34):

1. “Implement incident communications interoperability plans and protocols”
2. “Implement procedures to protect information facility and communication network systems”

Measures and metrics to determine accomplishment of these tasks are given as the following (FEMA, 2007b, p. 34)

1. “Percent of communications sent and received that are completely understood without ambiguity by the sender or the intended receiver - 90%”
2. “Frequency with which communications back-up is provided during emergencies when the conventional mode of communication fails or become overloaded - Continuous”

2.2.3 UN Office for Disaster Risk Reduction – Hyogo Framework for Action

Shortly after the Asian tsunami in 2005, the Hyogo Framework for Action (HFA) 2005-2015 was developed at the World Conference on Disaster Reduction in Kobe Japan (UN/ISDR, 2005). The conference provided an opportunity to promote a strategic and systematic approach to reducing vulnerabilities and risks to hazards. The need to identify ways to build communities with better resilience to disasters was evident. As a result, the United Nations International Strategy for Disaster Reduction (UN/ISDR) office in collaboration with United Nations Office for the Coordination of Humanitarian Affairs (UN/OCHA) put forth three strategic goals as part of the Hyogo Framework for Action (UN/ISDR & UN/OCHA, 2008):

1. To integrate risk reduction into sustainable development and planning
2. To develop and strengthen institutions, mechanisms and capacities to build resilience to hazards
3. To incorporate risk reduction approaches into the implementation of emergency preparedness, response and recovery programs

To achieve the goals set out as part of the framework, the conference also outlined five specific priorities (UN/ISDR & UN/OCHA, 2008, p. 1):

1. “Making disaster risk reduction a priority”
2. “Improving risk information and early warning”
3. “Building a culture of safety and resilience”
4. “Reducing risks in key sectors”

5. “Strengthening preparedness for response”

As part of the fifth priority, strengthening preparedness for effective response, a guidance and indicator package for implementing the framework was created. In the package, the Hyogo Framework highlighted the essential role that disaster preparedness can play in saving lives when integrated into an overall disaster risk reduction approach. Preparedness for hazardous events is mainly concerned with two objectives, increasing capacity to predict, monitor and be prepared to reduce damage and strengthening preparedness to respond in an emergency and help those involved (UN/ISDR & UN/OCHA, 2008).

The essentials required for developing disaster preparedness capabilities is discussed as part of the framework. It outlines the importance of contingency planning and capacity analysis in strengthening disaster preparedness. Each section includes a suggested outcome and a set of indicators to help measure levels of preparedness and progress made. The indicators have various forms for measuring outputs and processes. Ideally, indicators developed during the preparedness phase can be used as a baseline for measuring change over time and across different contexts. In some instances the indicators serve as a checklist for ensuring preparedness activities are being undertaken. The indicators cover the following components of preparedness (UN/ISDR & UN/OCHA, 2008)

- “Holistic Approaches and Preparedness”
- “National institutional and Legislative Framework”
- “Coordination at the Local, National, Regional, and International Level”
- “Contingency Planning”
- “Capacity Analysis and Capacity-Building”
- “Hazard Monitoring, Forecasting and Early Warning”
- “Information Management and Communication”
- “Emergency Services and Stand-by Arrangements”
- “Incorporating Early Recovery into Preparedness Planning”
- “Resource Allocation and Funding”

Each component has a set of indicators developed specifically for each level of society: government, civil society, regional organizations and international actors (UN/ISDR & UN/OCHA, 2008)

2.2.3.1 The Red Cross and Red Crescent Implementation of the Hyogo Framework

Since the Hyogo Framework's conception in 2005, 168 governments and organizations have pledged support for implementation (UN/ISDR & UN/OCHA, 2008). One of the more prominent supporters of the Hyogo Framework is the International Federation of Red Cross and Red Crescent Societies (IFRC). As seen in the International Federation's global agenda in 2008, the IFRC committed to four goals: (1) reduce the deaths, injuries and impacts of natural disasters, (2) reduce the deaths, injuries and impacts of public health emergencies, (3) increase capacity to address situations of vulnerability, and (4) promote respect for diversity and human dignity (IFRC, 2008).

With the first goal in mind, the IFRC societies have been working with communities to strengthen their coping capabilities and resilience to natural disasters using the HFA. By integrating the HFA and lessons learned through experience, the International Federation and National Societies were able to develop their own framework entitled Framework for Community Safety and Resilience (IFRC, 2008, p. 1)

"The aim (of the Framework) is to support National Societies in the promotion and implementation of a holistic, integrated approach developed with and for communities in response to the multiple hazards they face (including those worsened by climate change) and incorporating health, environmental risks, and economic and social issues. The framework consolidates work undertaken to date to reduce underlying vulnerabilities to disasters as part of the Red Cross Red Crescent's commitments under the HFA."

By contributing to the goals and priorities of the HFA, the IFRC societies have given themselves an advantage in disaster preparedness. They are now part of a global network that shares the same goals and priorities when it comes to disaster risk reduction. The advantage

enables them to participate in large scale disaster relief operations in parallel with other organizations that have implemented the HFA.

2.2.4 Public Safety Canada – Emergency Measures Organizations

Emergencies stemming from natural disasters are, in most cases, localized events. Coastal and landlocked communities are vulnerable to different threats and therefore have different response measures in place. A village in Saskatchewan would most likely not have emergency response plans to deal with storm surges, but may well have somewhat similar plans to deal with overland flooding as a result of precipitation events. For this reason emergencies are managed at the community or provincial/territorial level. However, in some cases natural disasters can transcend jurisdictional boundaries and the scope of the emergency becomes much larger than the jurisdiction can handle. The Federal Emergency Response Plan (FERP) is the Government of Canada’s all-hazard response plan. The FERP is designed to complement response efforts from the provincial and territorial government. It does not override the provincial plans (Public Safety Canada, 2011b)

The provincial approach to preparedness is managed by their respective Emergency Management Organization or Emergency Measures Organization (EMO). Whether they go by emergency management or measures, they provide the same service to their inhabitants and collectively fall under Public Safety Canada. The EMO’s activities include planning, training, and responding to disaster situations. They are also responsible for research and the administration and delivery of financial assistance to their province (Public Safety Canada, 2013). By establishing provincial or territorial organizations, EMOs can address natural hazards and risks for their respective region. The following segment provides an overview of the EMOs for the four provinces and territories in which there are Canadian C-Change partner communities.

2.2.4.1 Prince Edward Island Emergency Measures Organization

The Prince Edward Island Office of Public Safety overlooks emergency services in the province. These services include the 911 Administration Office, the Fire Marshal's office and Emergency Measures Organization. The emergency measures organization is responsible for

the development and coordination of the provinces emergency management program in relation to emergencies and disasters in the province (PEI Office of Public Safety, 2013).

In an effort to prepare communities in PEI for emergency situations, a comprehensive response program was introduced. As part of the response plan two key documents can be found on the PEI EMOs website, the Municipal Emergency Management Guide (PEI Office of Public Safety, 2013) and the Municipal Emergency Measures Plan Template (PEI Office of Public Safety, 2012). The management guide outlines key components and steps to develop plans, create exercises and ensure resources have been identified before an emergency occurs. The document guides communities through the process of developing a municipal emergency program, writing the contingency and evacuation plan, and setting up the emergency operation centre (PEI Office of Public Safety, 2013). The Municipal Emergency Measures Plan Template provides municipalities with a starting point in developing an emergency measure plan. This all-hazards emergency plan template guides the emergency management actions of the community and describes activities and arrangements to deal with any emergency situation (PEI Office of Public Safety, 2012).

The documents issued by the PEI EMO are all-hazard emergency response oriented, however they provide breakdowns and case studies that may prove to be very helpful for this research. In the Municipal Emergency Management Guide, a sample table-top exercise called “Exercise October” was shown. This is discussed in further detail in Section 2.4.2.

2.2.4.2 Emergency Management British Columbia

British Columbia is the third most populated province in Canada. With over 4.6 million people (BC Stats, 2013), the province boasts a wide variety of services and resources as can be seen in their emergency planning resources. The provincial emergency program, Emergency Management British Columbia (EMBC) is the coordinating agency for all emergencies in the province. EMBC has the mission to enhance public safety through leadership and collaboration with all levels of the government, public and stakeholders involved (Emergency Management British Columbia, 2012a).

Similar to Prince Edward Island, British Columbia has an all-hazard emergency response plan. The All-Hazard Plan outlines the response framework for emergencies and disasters at scales that requires the involvement of EMBC. The framework involves a provincial all-hazards methodology, description of responsibility for key players at all levels, and an outline of the collaborative intergovernmental relationship and integration for emergency planning (Emergency Management British Columbia, 2012a).

In British Columbia the Emergency Program Act and the Local Authority Emergency Management Regulation states that local municipalities are responsible for developing emergency plans based on the hazards and vulnerabilities of their communities (Government of British Columbia, 2013). Often times, these plans will closely reflect the All-Hazard Plan for maximum interoperability within the system. It should be noted that the provincial All-Hazard Plan does not override the local authority plans. Instead, the provincial All-Hazard Plan will guide EMBC activities when the local municipality has declared a provincial state of emergency (Emergency Management British Columbia, 2012a).

Aside from the provincial All-Hazard Plan, EMBC has a flood response plan that is specific to dealing with rising water levels and storm surges. The British Columbia Flood Response Plan of 2012 describes the methodology to be taken by the government in the event of a flood. The plan focuses on readiness and response activities for floods at the regional or provincial level (Emergency Management British Columbia, 2012b).

Water level advisory is provided by the River Forecast Centre in three advisory levels (Emergency Management British Columbia, 2012b):

1. High stream flow advisory: river levels are rising rapidly, but no major flooding is expected. Minor flooding in low-lying areas is possible.
2. Flood watch: river levels are rising and may exceed bankfull. Flooding of areas next to the rivers may occur.
3. Flood warning: river levels have exceeded bankfull. Flooding of areas next to the river will occur.

In the event of a high stream flow advisory resources are pre-positioned and the media is contacted to alert the public. Public flood impact mitigation techniques are relayed through the media. Local authorities will assign observers and monitor the water level closely. If a flood watch advisory is issued by the river forecast centre, local authorities will actively patrol river banks to monitor the situation. Dikes, dams and other water control infrastructures are constantly monitored and spillways are kept clear. These measures are conducted on top of the high stream flow advisory measures. Flood warning advisories indicate a high probability of a flood that will lead to damage. Provincial response will depend on the severity of the event and the areas affected (Emergency Management British Columbia, 2012b).

2.2.4.3 Nova Scotia Emergency Management Office

Emergency preparedness in Nova Scotia is outlined in the Nova Scotia Emergency Response Plan and the Emergency Management Act of 2009. The all-hazard approach document outlines methodologies for an effective, efficient and coordinated emergency response plan. The document was designed to guide actions and decisions at the provincial level, whether it involves a response from a single department on a contained site or a fully coordinated joint response across multiple departments and jurisdictions (Nova Scotia EMO, 2012).

The response effort as outlined in the Nova Scotia Emergency Response Plan is coordinated through the Joint Emergency Operations Centre (JEOC). The centre has the mission to facilitate and maintain an efficient system for planning, managing and executing response and recovery operations with the help of technology. The planning process at the JEOC follows the incident command system's P-model as shown in Figure 2-2.

The P-model is commonly seen in incident command systems management and the following section is based on the P-model as presented by FEMA in their Incident Action Planning Guide (FEMA, 2012). The Nova Scotia Emergency Response Plan did not explain the stages of the P-model. It should also be noted the Nova Scotia Emergency Response Plan

focuses on the action and decision making process of responding. Not as much emphasis has been placed on the resources required to be prepared.

The P-model describes the decision making process that occurs at the JEOC once an incident or event has occurred. The figure depicts the stages of the incident action planning process. The leg of the “P” includes the initial steps to gain awareness of the situation and establish the organization for incident management. Once incident management is completed the process shifts into a cycle of planning and operation (FEMA, 2012).

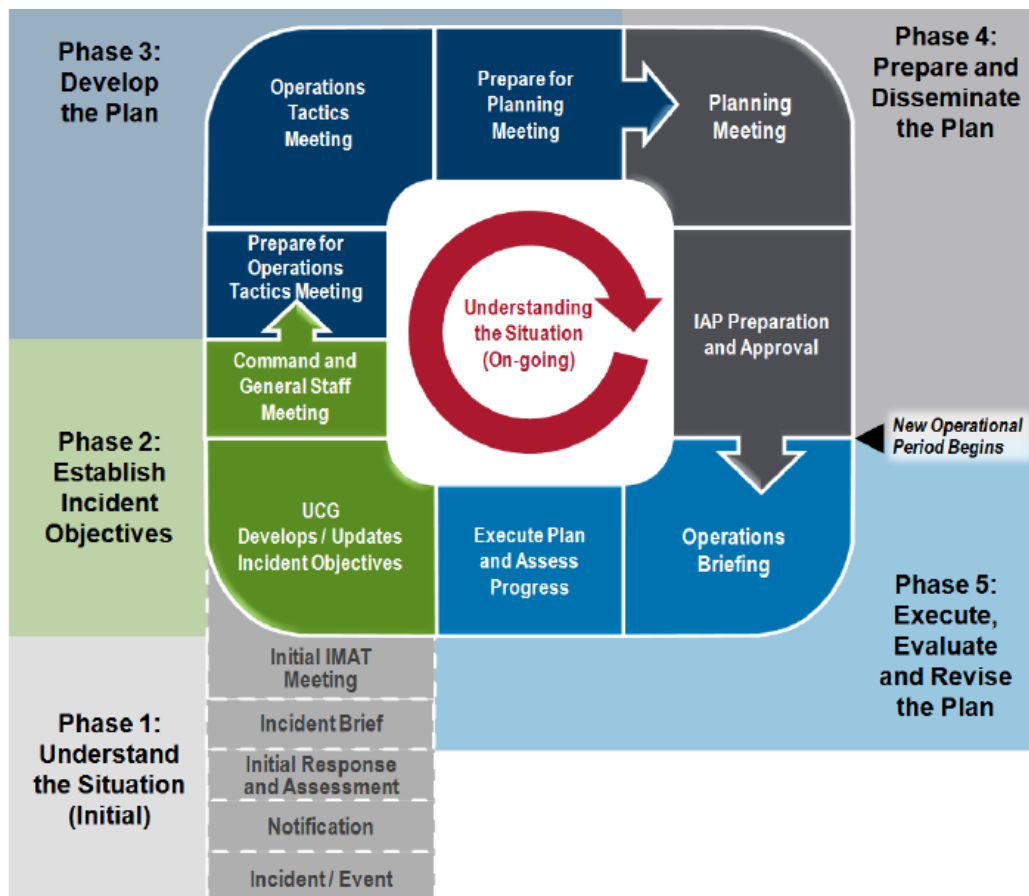

Figure 2-2 The incident command system’s P-model. Source: FEMA (2012)

Phase 1 of the P-model focuses on gaining an understanding of the situation and establishing initial priorities based on community values. The activities carried out to acquire more information about the situation include gathering, analyzing and displaying information regarding the scale, scope, complexity and impacts of the event at hand. Examples of the

information required are the boundaries and scope of the incident, number of displaced survivors, infrastructure damage, resources on hand, and health related concerns. A comprehensive understanding of the situation is essential to properly develop and implement an incident action plan. The final step of the phase is to assemble an incident management assistance team. Once completed the process moves in an operation cycle (FEMA, 2012).

The operation cycle commences with phase 2, establish incident objectives. A unified coordination group develops or updates the incident objectives that drive the response operation. Incident objectives are based on realistic expectations that can be accomplished when all available resources (e.g., vehicles, generators, gabion dikes) are effectively deployed. In the initial stages following an incident, objectives are general and simple. As the operation loop progresses and the situational awareness and status has improved, then objectives can become more specific. An example of a general objective is to restore electrical service in the county. Once the situation has improved, then a time component can be added to the objective. For instance, restore power to more vulnerable areas first within a given time frame (FEMA, 2012).

Phase 3 of the P-model calls for developing strategies to achieve the incident objectives previously set out and to create tactics to accomplish the strategies. Strategies, as defined by FEMA, describe actions and resources required to achieve specific objectives. They are distinct from tactics, which address the conduct of specific operations (FEMA, 2012).

As part of the strategy developing process, work assignments and responsibilities for the response are allocated at this stage as well. Organizations are to assign responsibilities based on their internal hierarchical structure, and this may vary from organization to organization (FEMA, 2012).

In phase 4, prepare and disseminate the plan, the incident action is approved by the unified command group. As part of policy, this phase requires key supporting documents and paperwork to be completed. The supporting documents will depend on the event or incident to

be addressed. In most instances they include: Incident Radio Communications Plan, Incident Map, Assignment List, Air Operations Summary and Medical Plans (FEMA, 2012).

Once all plans and strategies have been approved, phase 5 calls for execution, evaluation and revision of the plan. Phase 5 begins with the operations briefing and continues as the incident action plan is executed, followed by the evaluation (FEMA, 2012).

The Nova Scotia Emergency Management Office Incorporates the P-model into their decision making process as well (Nova Scotia EMO, 2012).

2.2.4.4 Nunavut Emergency Management

Nunavut Emergency Management is part of the Community and Government Services Department of Nunavut. They are responsible for developing emergency response plans and coordinating emergency response operations in the territory. Training for emergency responders and education for public awareness and preparedness is coordinated through the Nunavut Emergency Management also (Government of Nunavut, 2010). The City of Iqaluit has a Climate Change Adaptation Action Plan developed in 2010 that mentioned the need to improve emergency response plans to adapt to a changing climate (Lewis & Miller, 2010). The need for improved plans can be seen in the lack of information on the Nunavut Emergency Management website.

2.2.5 International Emergency Management Group – International Emergency Management Assistance Compact

The International Emergency Management Assistance Compact (IEMAC), adopted in 1998 by the International Emergency Management Group (IEMG) following the ice storm, provides a structure for inter-jurisdictional and international mutual aid (IEMG, 2013). It establishes the procedures whereby a disaster impacted jurisdiction can request the aid of another quickly and efficiently. The plan resolves two key issues, liability and reimbursement. The requesting jurisdiction assumes all liability for the out-of-jurisdiction aid and agrees to reimburse the aid provider with all deployment related costs (IEMG, 2013). The members of IEMAC are shown in Table 2-2.

If a jurisdiction is in a state of emergency and requires the assistance of another, there are two approaches that can be taken to initiate IEMAC and request assistance as shown in Figure 2-3. The activation process starts with the requesting jurisdiction in box 1. The authorized representative of this jurisdiction may contact another jurisdiction if they feel the emergency can be handled with the aid of another jurisdiction. If the emergency is of a larger scale, the authorized representative may choose to contact a member of the IEMG, where a call for aid can be sent out to all participating jurisdictions. The aiding jurisdiction would check its capacity to respond the emergency before responding. If the aiding jurisdiction agrees then an information request form is filled out and both parties must agree on the conditions as laid out by the IEMAC (IEMG, 2013) .

Table 2-2 Jurisdictions participating in the IEMAC. Source: IEMG (2013)

United States Jurisdictions	Canadian Jurisdictions
Maine	New Brunswick
Massachusetts	Newfoundland and Labrador
New Hampshire	Nova Scotia
Vermont	Prince Edward Island
Connecticut	Quebec
Rhode Island	

The IEMAC has proven to be a valuable tool for responding to emergencies as seen in November 2004 when Nova Scotia was hit with a snow storm that brought over 60 cm of snow to some regions in the span of 2 days. The storm hit hardest in the Annapolis Valley, the Halifax region and North-Eastern Nova Scotia between Truro and the Canso Causeway. Residents in rural areas were left in the dark without running water for up to a week. The utility companies received more than 250 000 calls in the 12 hours after the storm. With the unexpected demand, emergency crews from New Brunswick and Maine were called in to assist in restoring power to those in need. Two hundred emergency crews, including 55 from New Brunswick and Maine, worked around the clock to restore power and running water (Environment Canada, 2004).

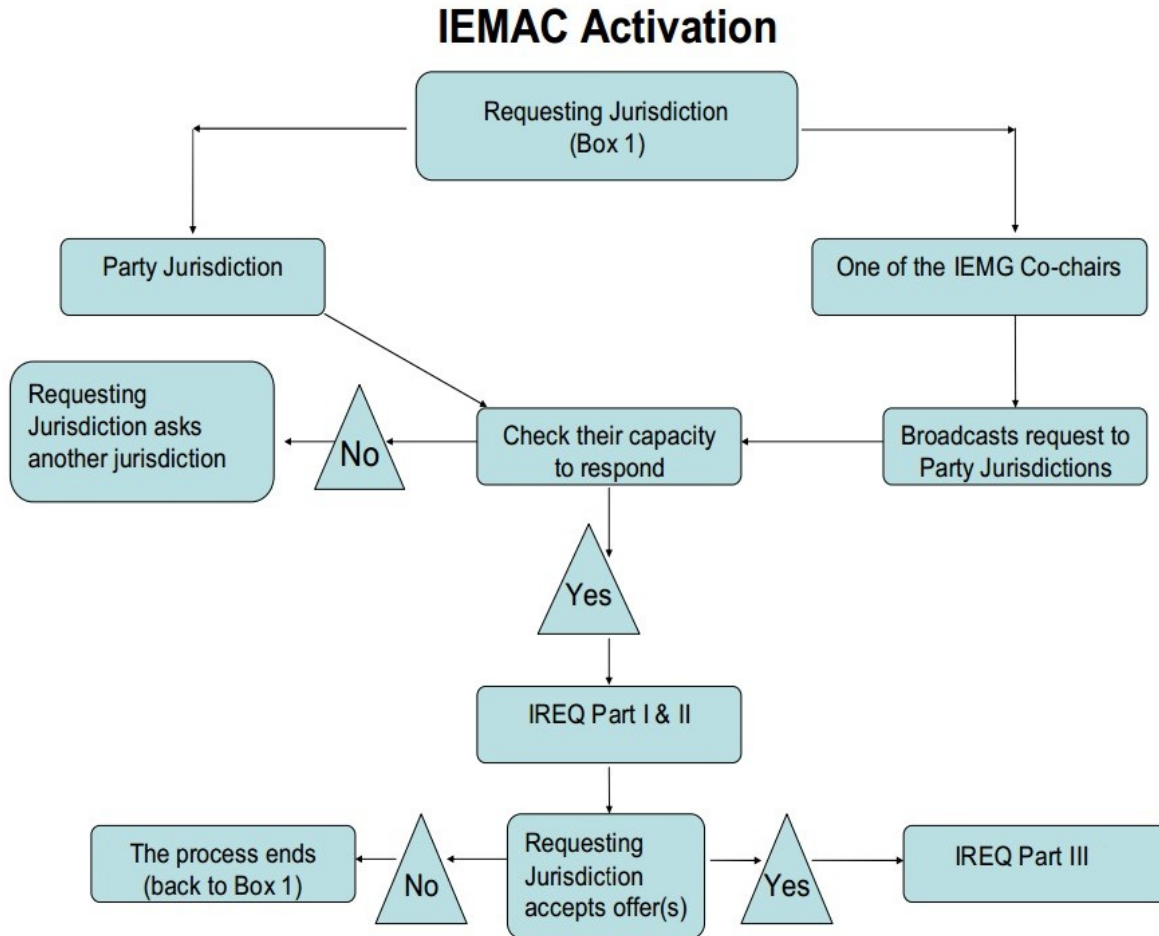

Figure 2-3 IEMAC activation process. Source: IEMG (2013)

2.3 Preparedness Measures

Given the persistent concerns about preparedness, many have tackled the issue from a quantitative point of view. For this reason, valuating and quantifying the components of preparedness to develop preparedness measures, checklists and indices have been pursued by many.

2.3.1 Preparedness Indicator Checklists

The checklist approach focuses on developing a list of items (guidelines) or set of indicators that a community requires in order to be prepared for a storm. In general, these guidelines or list of indicators are based on ingredients of preparedness that are readily

countable (Jackson, 2008). They do not take into account the dynamics of the system, the operations aspect.

This approach is most easy to follow for decision-makers and allows the common public to visualize areas that need improvement (O'Leary, 2004). Shortages in preparedness ingredients can easily be identified from the list of indicators and appropriate actions can be taken. In a sense, it is the most user friendly approach and lays out the requirements clearly (Jackson, 2008).

Checklist style approaches often utilize the terms guidelines, indicators, and/or capabilities to identify the components of the checklist. The NWS StormReady Program, FEMA Target Capabilities List and the Hyogo Framework for Action all take this approach to defining preparedness.

2.3.2 Preparedness Indices

A different approach to defining preparedness is through the use of an aggregated measure or index of preparedness. The creation and use of an index has been a popular methodology for evaluating relative levels of some state, whether economic, health, quality of life or another state of being (O'Leary, 2004; Simpson, 2008). In some cases, there have been indices that attempt to capture levels of social vulnerability to natural hazards (Adger, 1999). Preparedness indices consist of a set of indicators, and through the application of a mathematical method the indicators are assigned scores and an index value is derived to measure relative preparedness.

A number of issues arise when attempting to construct disaster-preparedness measures and indices. Potential problems include subjectivity, bias, weighting, mathematical combinations, and selection of indicators. The following discussion examines several indices and provides a breakdown of their structure and approach.

In 1987, Gillespie and Streeter proposed a method of conceptualizing and measuring disaster preparedness of an organization through the use of seven items that contributed to an overall measure of preparedness. The summative measure of preparedness was scored upon

how the organizations responded to the seven questions. The questions covered past training experience for the organization, future training opportunities, planning, and Integrated Emergency Management System (IEMS) Concepts. The IEMS concept was coined in the 1980s by FEMA as an all-hazard approach to the coordination, direction and control of disasters independent of their type, origin, size, and complexity. The responses were scored based on their type. For example, a yes or no response from the question of “Does your organization have a specific emergency response plan to guide its operation in a disaster?” would yield a score of 1 for yes and 0 for no. Questions that yield a quantitative responses such as “During the past three years, how many different times has a representative of your organization participated in simulated disaster exercises?” will have a scoring system of 0, 1, 2 or 3 for 3 or more times. The scores from the seven items were normalized onto a single dimension with the help of z-distributions. The average between the scores became the preparedness measure (Gillespie & Streeter, 1987).

In 2006, Simpson and Katirai from the Centre for Hazard Research and Policy Development at the University of Louisville proposed an integrative framework for disaster preparedness index (DPI). Various models have been created in the past to evaluate community exposure and risks to a disaster but not so much for preparedness. They proposed a disaster resiliency index that is a function of vulnerability and preparedness (Simpson & Katirai, 2006).

$$\text{Disaster Resiliency Index (DRi)} = \frac{\text{Preparedness Index (Pi)}}{\text{Vulnerability (V)}} \quad (2-1)$$

where $\text{DRi} > 1$ means that the community is more resilient, and $\text{DRi} < 1$, the community is less resilient.

The disaster resiliency index can be considered to be a function of a community’s preparedness in a ratio relative to its exposure and a set of hazards. Resiliency and community preparedness are directly proportional (Simpson & Katirai, 2006).

The key variables, measures and metrics for such a model are developed using a collaborative and consensus based process among literature in the field. The individual

measures used are determined and weighted from a list of indicators used in previous literature. The indicators are identified as either a functional measure of preparedness (FM) or a vulnerability measure (VM). Once these measures have been identified and selected from previous literature, they can be scaled and normalized to fill the following equations (Simpson & Katirai, 2006).

The first equation derives the preparedness index for the given community.

$$Pi_x = \sum (w_1FM_1 + w_2FM_2 + \dots + w_nFM_n) \quad (2-2)$$

Where:

Pi = community preparedness (P) index

x = location of community

w_n = weight for a given measure

FM_n = functional measure/indicator

n = number of measures

The second equation derives the vulnerability score for the given community

$$V_x = \sum [H_a p_a f_a + H_b p_b f_b + \dots + H_n p_n f_n] \times \sum (w_1VM_1 + w_2VM_2 + \dots + w_nVM_n) \quad (2-3)$$

Where:

V = Community vulnerability

X = Location of community

$H_{a,b,c...}$ = Hazard agent (earthquake, hurricane ...)

f = Frequency of hazard

p = Probability of hazard

w = Weight

VM = Vulnerability measure/indicator

n = number of measures

By inserting vulnerability (V) and preparedness index (P_i) into the disaster resiliency index equation mentioned previously, one can derive a score that is directly proportional to the community's preparedness level (Simpson & Katirai, 2006).

Disaster Indexing Measurement Model Diagram

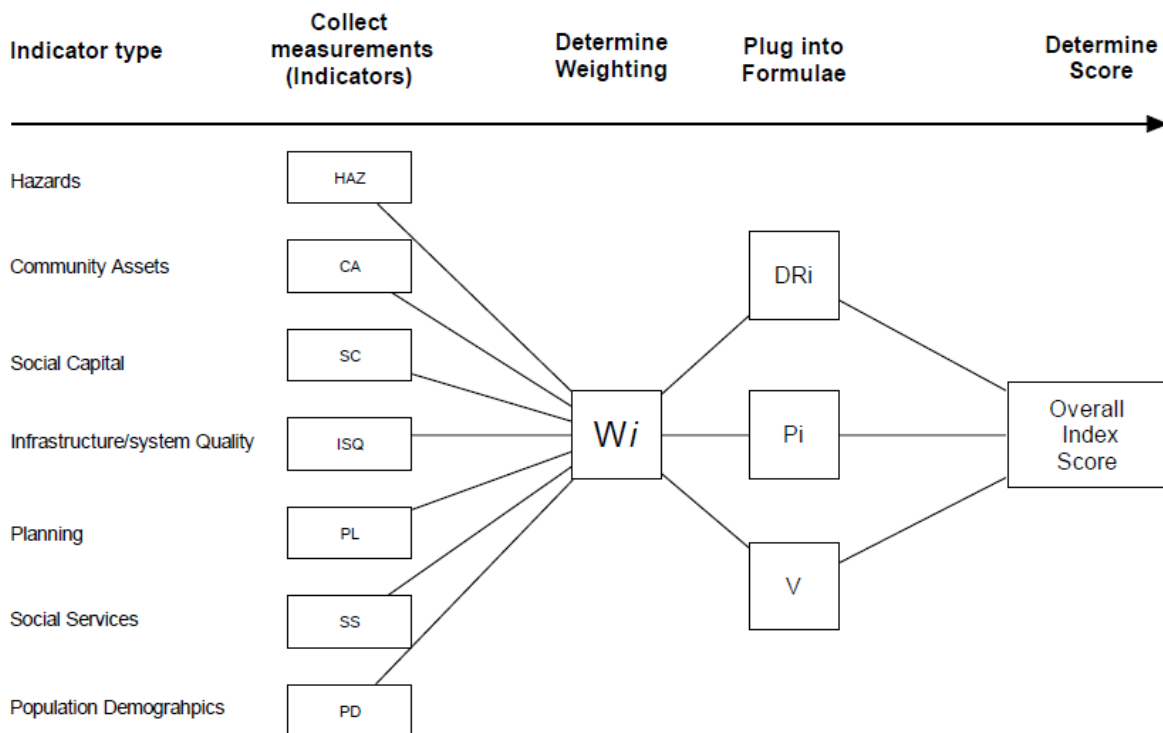

Figure 2-4 Disaster index measurement model diagram. Source: Simpson and Katirai (2006)

Figure 2-4 summarizes how the disaster preparedness index is formulated. The measurement indicators are determined from a listing of indicators used in other models.

2.3.3 Response Reliability

As seen from the checklists and indices, attempts to assess preparedness have focused on quantifying resources or measures that are easiest to quantify and identify. It is evident that having the right quantity of equipment or personnel is essential for a community to be prepared. Without the right tools the operation would not be able to succeed. Other efforts

have gone beyond inventorying resources to developing preparedness standards to assess less tangible components of preparedness. These efforts generally produce an action plan or framework for response. They can be viewed as the instruction manuals providing guidance on how to proceed in the case of an emergency. At this stage, the tools and instructions are both evident as modules of preparedness. With an excess of resources and an optimal response plan, communities still lack a response to the fundamental question of: How certain can we be that the systems we have put in place to respond to storm surges are able to deliver when called upon? The answer to this question lies in evaluating the effectiveness or reliability of the system once it is in practice. Confidence that response plans are able to execute effectively depends on the reliability of the system that is executing these plans (Jackson, 2008; Jackson et al., 2011).

Emergency preparedness plans can be deceiving in many cases. In theory, access to aid supplies and a plan to deliver them to areas in need is a great preparedness strategy. However, if these areas of need are only accessible by a single road that can easily wash out in the event of a storm then the plan is no longer as relevant to the overall preparedness state.

The RAND Corporation has brought light to this issue by proposing that response reliability should be evaluated as part of preparedness measurement efforts. Such assessments should be based on the nature of the system of organizations, governments and public and the factors that contribute to how well they respond as a whole (Jackson, 2008). The RAND Corporation suggested mapping the system and identifying the elements that shape the performance of a given task. In other words, the capabilities are mapped with factors that may interrupt the process. Reliability measures can be tabulated by estimating the likelihood of breakdowns and identifying their impact on performance of the system (Jackson, 2008; Jackson et al., 2011). Figure 2-5 is an example of a fault analysis for identifying risks to evacuation reliability using buses.

This example is seen in areas prone to flooding and the population needs to evacuate. The response operation is shown in the white boxes, while the shaded boxes show possible

disruption to the evacuation operation. The events are not exhaustive but they do illustrate factors that are responsible for the reliability of such a system. Simply having a system in place is not merely enough. Preparedness is heavily dictated by the reliability of the system in place (Jackson, 2008).

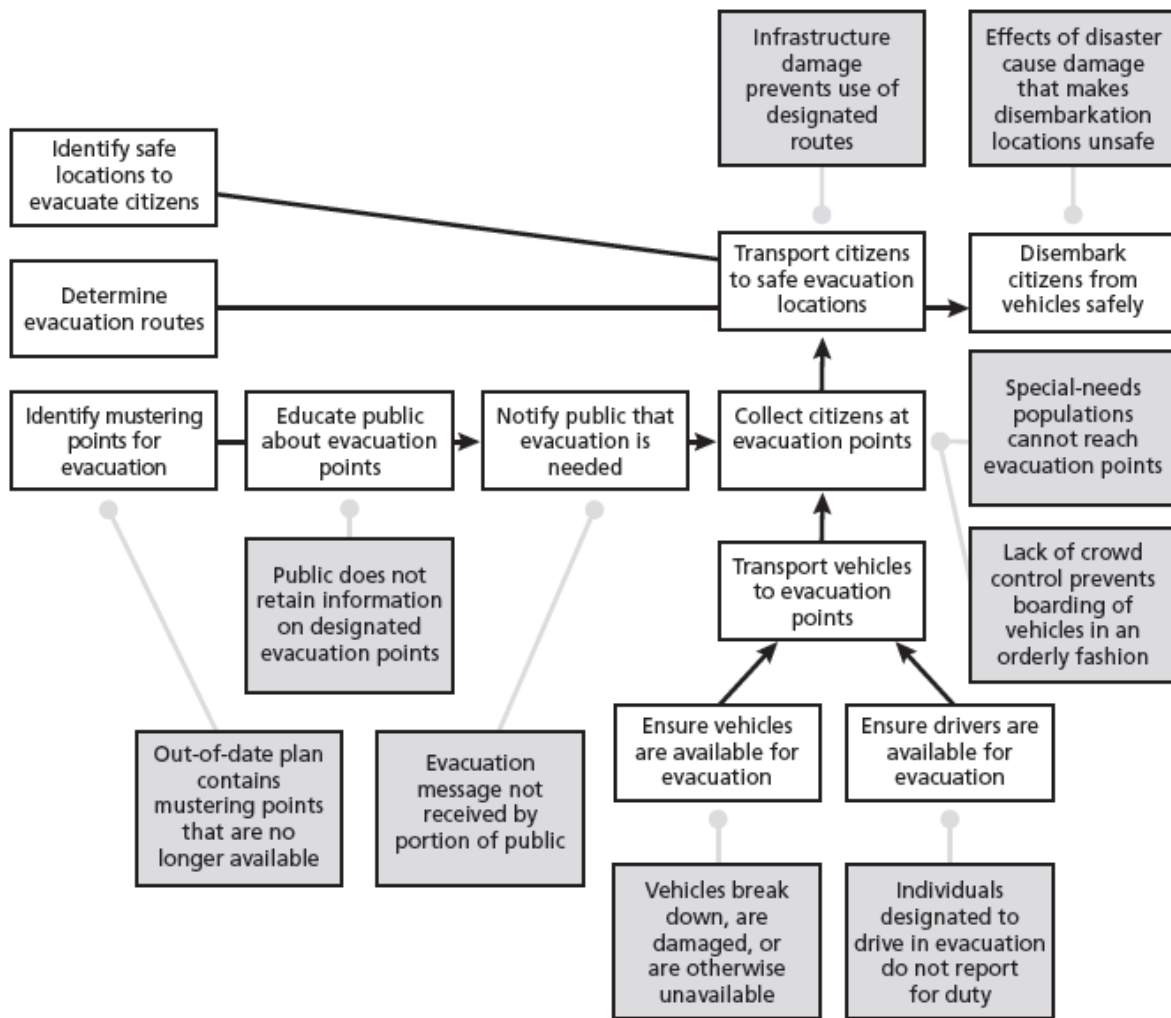

Figure 2-5 Example fault tree for the analysis of identifying risks to evacuation reliability. Source: Jackson (2008)

2.4 Evaluation and Preparedness Modelling

The application of modelling techniques to preparedness has proven to be a valuable tool. Modelling and simulation studies have been conducted to predict vulnerable areas to

storms, and train responders. Simulation studies can also be done as a role playing exercise, commonly referred to as a table-top exercise.

Section 2.4.1 reviews modelling and simulation approaches for emergency situations while Section 2.4.2 examines emergency table-top exercises.

2.4.1 Emergency Situation Modelling

This section reviews emergency situation models. Four models supported by organizations, such as the US National Weather Service and the Canadian Meteorological Centre of Environment Canada, provide modelling information for describing and predicting weather related impacts. The later sections review simulation approaches applied to public education and professional training through the use simulation gaming.

2.4.1.1 Sea, Lake, Overland Surges from Hurricanes (SLOSH)

In the days leading up to arrival of Hurricane Sandy in 2012, emergency responders were tasked with deciding which regions of the Eastern Seaboard had to be evacuated due to imminent floods. The National Weather Service of the United States developed a tool called the Sea, Lake, and Overland Surges from Hurricanes (SLOSH) model to provide guidance when a hurricane is threatening by providing the predicted surge height in a specific region (Glahn et al., 2009). In most cases the model is used as a hazard analysis study for hurricane evacuation and training by FEMA, the U.S. Army Corps of Engineers and local state or municipal responders. It has been applied to 38 specific coastal areas in the United States, called basins that run along the eastern coast down into the Gulf of Mexico coast (Glahn et al., 2009; NOAA, 2003).

The SLOSH model is run by the National Hurricane Centre to estimate storm surge heights resulting from historical, hypothetical, or predicted hurricanes by taking into account the atmospheric pressure, size, forward speed, and track data. These parameters are used to create a model of the wind field which drives the storm surge. The model is constructed on a set of physics equations which are applied to the local topological and bathymetrical data. It also incorporates physical barriers such as roads, bridges, trees, and levees (NOAA, 2003).

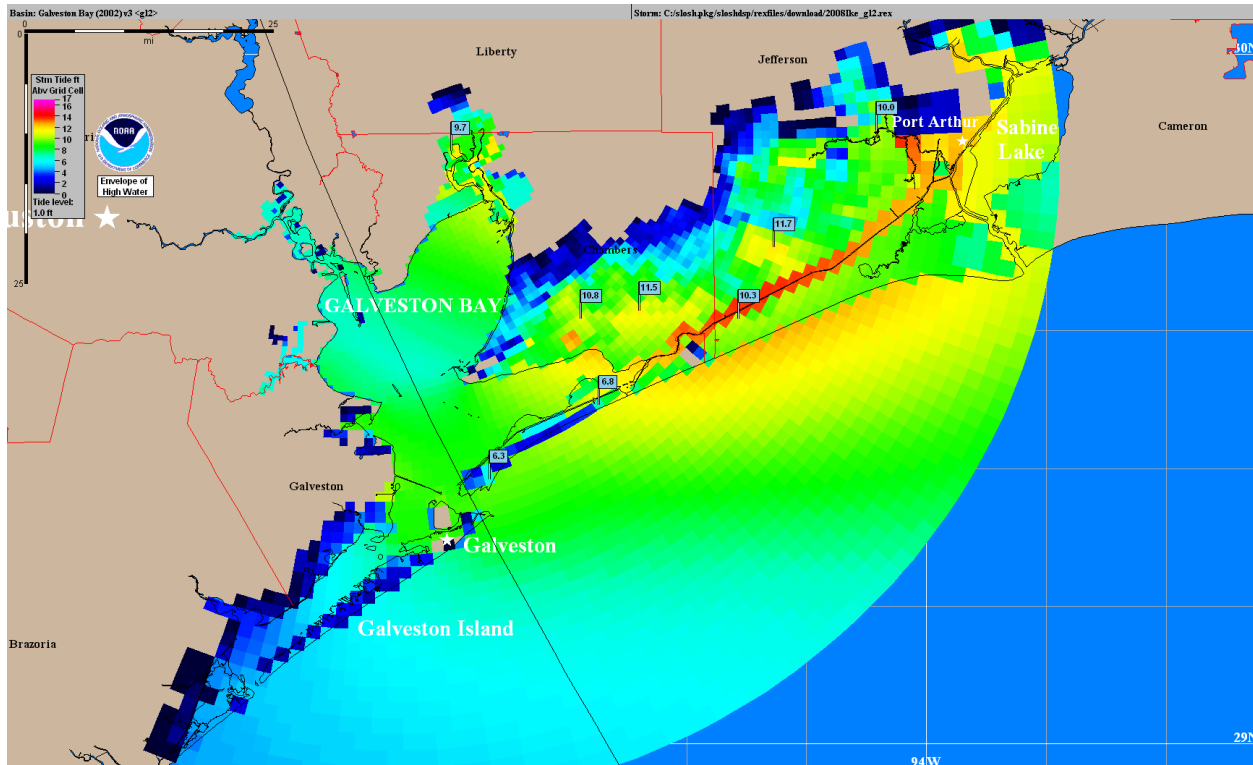

Figure 2-6 Sample output of the SLOSH model for Hurricane Ike in 2008 in Galveston Bay, Texas.
Source: NOAA (2012a)

Currently, there are three approaches that the SLOSH model can take on, deterministic, probabilistic, and composite modelling. The deterministic approach is based on the assumption of a perfect forecast. For a realistic simulation using the deterministic approach, the model must have accurate meteorological inputs. These inputs have the form of pressure, radius of maximum winds, location, direction, and forward speed. The deterministic approach proves to be a great tool for simulation and training exercises where the storm is required to be generated. The probabilistic approach incorporates statistics of past forecast performances to generate an ensemble of SLOSH runs based on distributions of tracks, intensity, and size errors. The composite SLOSH model predicts surge levels and location by running SLOSH several thousand times with hypothetical hurricane conditions. The outputs generated from the composite model are the Maximum Envelopes of Water (MEOW) and Maximum of the MEOWs (MOM). This is determined to be the best method of analysis for surge vulnerability since it takes into account forecasting uncertainty. A screenshot of the SLOSH program output is shown

in Figure 2-6 for the basin of Galveston Bay, Texas during Hurricane Ike. The colours represent surge heights for their respective quadrant (NOAA, 2012a).

The advantage found in using the SLOSH model is its efficiency in generating results in real time. This makes it an ideal tool for operational use. The model can resolve the flow dynamics of the surge as it passes through barriers (NOAA, 2003). The disadvantage of the SLOSH model is that it lacks the ability to account for waves on top of the surge level. It also does not account for normal river flow and rain, nor does it model the tide level. In most cases the tide level can be inputted as an initial water level before the simulation run (NOAA, 2003; NOAA, 2012a).

2.4.1.2 Global Environmental Multiscale Model (GEM)

The Global Environmental Multiscale (GEM) model was developed by the Canadian Meteorological Centre of Environment Canada. The GEM model presents an integrated forecasting and data assimilation system to meet the foreseeable weather forecasting needs of Canada. The motivation behind creating a global model is to forecast the weather, address climate issues such as global change, and examine air quality issues such as smog, and ozone depletion. The model is often used to predict short range forecasts and is often integrated with the Global Forecast System model as designed by the Nation Weather Services of the United States to North American Ensemble Forecast System (Environment Canada. Canadian Meteorological Centre, n.d.).

2.4.1.3 National Oceanic and Atmospheric Administration – Sea Level Rise and Flooding Impacts Viewer

The National Oceanic and Atmospheric Administration developed a tool to enable users to visualize sea level rise and how it may affect their community. The Sea Level Rise and Flooding Impacts Viewer is a screening level tool that enables the user to adjust the increase in sea levels and explore their community through different visualization. It is interesting to note that the viewer also enables users to compare socioeconomic vulnerability with flood risks (NOAA, 2012b).

2.4.1.4 Marine Environmental Observation Prediction and Response (MEOPAR)

Formed in 2012, the Marine Environmental Observation Prediction and Response Network (MEOPAR) brought together leading Canadian researchers in the fields of marine environment research and hazard management. Through research, MEOPAR seeks to reduce Canada's vulnerabilities and exposure to marine emergencies. This goal is to be carried out by developing disaster risk reduction tools and proposing positive adaptation measures for addressing the impacts of the ocean (MEOPAR, 2013).

MEOPAR is currently developing several weather prediction tools. Of interest to this study are the Building a Network of Fixed Coastal Observing and Forecast Systems and the Climate Change and Extreme Events in The Marine Environment projects. The first project will build observation and prediction systems in the Halifax Harbour and the Southern Strait of Georgia. The data acquired from these systems will help forecast sea levels, waves, currents, and biogeochemical properties on a real-time basis for a multiple users like port authorities, municipalities, and the oil and gas sector. The second project will translate scientific weather prediction data into tools to increase preparedness and mitigate the impact of extreme weather events in coastal regions (MEOPAR, 2013).

2.4.1.5 UN/ISDR Stop Disaster Simulation

Simulation as tool is not only used for professional training, but is often used in public education as well. The United Nation's International Strategy for Disaster Reduction as implemented by the Office for Disaster Risk Reduction took the simulation gaming approach to educate the public about preparing for threats from natural disasters. The game simulates threats from tsunamis, floods, wildfires, hurricanes and earthquakes (UN/ISDR, 2007).

The online game aims at teaching the public how to build safer communities for preparation against natural disasters. The lessons imparted in the simulation game include how location and construction materials of houses can make a difference when disasters strike. Early warning systems, evacuation plans and education all contribute to being prepared (UN/ISDR, 2007).



Figure 2-7 UN-ISDR Stop Disasters simulation game screenshot Source: UN/ISDR (2007)

Figure 2-7 is a screenshot of the Stop Disasters game. The game gives the player several disaster scenarios to choose from and a budget to work with. The player is tasked with upgrading existing infrastructures, building new ones and educating the public about responding to the imposing threats. The player must finish the required tasks before the disaster strikes. Once the disaster event has occurred a report is given in with suggestions and recommendations for how to prepare in the future if the player failed at preparing the simulated community (UN/ISDR, 2007).

2.4.1.6 Environmental Tectonics Corporation - Advanced Disaster Management Simulator

Technology is often used to simulate a more realistic scenario during responders training. The Advanced Disaster Management Simulator (ADMS) produced by the

Environmental Tectonics Corporation incorporates the use of CAD and produced 3D models and environments for the purpose of professional training. ADMS is aimed at training incident commanders, command post staff, and emergency vehicle operators at all levels. The program offers training for individuals or as teams for a more realistic scenario where communication amongst team members is vital (Environmental Tectonics Corporation, 2013).

The advantage that the ADMS program provides is a fully customizable environment. The scenarios and spatial elements can be constructed from scratch based on community needs and requirements. ADMS provides a comprehensive toolset for community simulation instructors to control, assess and debrief after incident command exercises. From the instructor's point of view, they have a bird's eye view of the operation environment. This allows for better management during the exercise and areas that require improvement can be identified much easier (Environmental Tectonics Corporation, 2013).

ADMS is widely used for emergency responder training in large scale operations. Their notable clients are New York City's Office of Emergency Management and the Ottawa International Airport (Environmental Tectonics Corporation, 2013).

2.4.2 Emergency Table-Top Exercises

A table-top exercise is a simulated emergency in which key players and actors can carry out actions, functions, and responsibilities that would be expected of them in a real emergency. Exercises are often used to validate plans and procedures that will lead to increasing preparedness. These table-top exercises are the most effective means of testing and validating plans, policies, procedures, training, equipment, and interagency agreements for rare or hazardous situations. If the unfortunate event of a natural disaster occurred more often, then communities would have more experience in dealing with them. This is not a situation that one would wish upon. Therefore a table-top exercise provides the opportunity to test out the preparedness measures in place. The following are examples of table-top exercises used in the field of disaster preparedness training.

2.4.2.1 Emergency Management Ontario

The Guidelines for the Development of an Exercise Program by Emergency Management Ontario will assist governments and communities in developing a full exercise program to be used for training. The Guidelines for the Development of an Exercise Program are a tool that provides a risk based framework with guidance for planning, conducting and evaluating exercises. These guidelines will enable organizations or communities to test elements of their emergency plans, including equipment and functions of personnel. Rather than presenting a predesigned exercise as seen with other approaches, the guidelines provide a standardized process and framework for communities to design their own table-top exercises (Emergency Management Ontario, 2009).

The document is organized into three sections: Process of Exercise Program Development, Discussion-based Exercises, and Operations-based Exercises. The first section focuses on key concepts in managing exercises and the phases involved in this process. The latter two sections focus on requirements for the conduct of discussions and operations of the exercises. The appendix also contains a table-top creation template that may prove to be valuable for this study (Emergency Management Ontario, 2009).

2.4.2.2 FEMA Table-Top Exercises

In 2010, FEMA's Private Sector Division, Office of External Affairs created a series of table-top exercises as a tool to help private sector organizations advance their organization's preparedness. Table-top exercises are designed to help test a hypothetical situation for a group of responders, such as a natural or man-made disaster, and evaluate the ability of the group to cooperate and work together, as well as test their readiness to respond. The packages contain a PowerPoint presentation for the table-top activity that includes notes and discussion questions for the exercise facilitator. The exercise packages can be downloaded from the FEMA website for communities to examine the first 72 hours of a response to a catastrophic disaster. The interactive exercise was designed to spur discussion and develop innovative ways to fill gaps in community emergency management plans (FEMA, 2013).

The first table-top exercise of the series entitled *Whole Community: Planning for the Unthinkable* is designed to simulate an unprecedented catastrophic event, a maximum of maximum approach. The presentation is given as three modules that cover the catastrophic response, crisis communication and search and rescue. Each module is introduced with a simulated news report video, included in the downloadable package. Another exercise package to be noted is the Hurricane Exercise. The exercise goal in this case is to prepare to respond and recover from a category 5 hurricane (FEMA, 2013).

2.4.2.3 PEI Municipal Emergency Management Guide – Exercise October

Prince Edward Island’s Municipal Emergency Response Guide includes a table-top activity to prepare for emergency situations. Exercise October focuses on the planning committee and organization of the EOC. The exercise can be conducted with little preparation as a table-top exercise to exchange information from the key players in response to an emergency (PEI Office of Public Safety, 2013).

The following is a quick overview of what Exercise October brings. The scenario presented is a severe winter storm on the hypothetical date of February 24th combined with high winds and freezing rain. The ground is already covered by 30 centimetres of snow to increase the difficulty of the operation. The Municipal Emergency Management Coordinator is apprehensive about the situation and wishes to set up the EOC. What are the questions to consider when setting up the emergency operations centre? As the storm progresses, different situations are presented and a series of questions follow for the key players to discuss and share information as a training exercise (PEI Office of Public Safety, 2013).

It is important to note afterwards, how things can be done differently and how participants felt about the decisions as a whole (PEI Office of Public Safety, 2013).

2.5 Applications

In the case of an emergency, time is of the essence. An effective response implies knowing who is in charge and willing to take action. The Emergency Management Act of Canada

sets out roles and responsibilities for governments across the spectrum of emergency management in Canada. The act covers prevention/mitigation, preparedness, response and recovery and critical infrastructure protection. The Act is an integral part of the Government of Canada's efforts to protect its inhabitants. The Act provides the following (Government of Canada, 2013):

1. Gives responsibility to the Minister of Public Safety to provide leadership and sets clear goals for emergency management in Canada
2. Establishes clear roles for key players in the emergency management spectrum
3. Enhances collaborative practices and information sharing among different levels of government
4. Gives authority to the Minister of Public Safety and Minister of Foreign Affairs to coordinate Canada's response to an emergency occurring in the United States

In 2008, the Senate of Canada's Committee on National Security and Defence produced a report on emergency preparedness in Canada. In summary, the Canadian Government is not "moving quickly enough" to minimize damage in the event of a hazard. The report also focuses on what the government has done in recent years in preparation for the next large disaster event (Canada Senate, 2008).

The all-hazard document claims that as of 2008 the government has inched towards improving national coordination for disaster relief, but more is needed for Canadians to be prepared. The committee examined disaster response capacity in areas that include government services in emergency situations, capacity of Canadian forces to offer assistance, funding municipalities, public communication, and many others. The results were attained qualitatively through testimonies from more than 110 witnesses from 2001 to 2008. Two emergency preparedness surveys were also conducted, one in 2003 and the other in 2007. The results identified 12 problems in the Canadian response system that can be improved on (Canada Senate, 2008):

1. "Lack of emergency management"

2. "Use of the Canadian Forces for domestic emergencies"
3. "Hidden emergency caches"
4. "Lack of funding for equipment and training"
5. "Poor collaboration among governments"
6. "Lessons learned not remembered and poor leadership on best practices"
7. "Emergency public communications"
8. "Lack of first responder interoperability"
9. "First responders ignored"
10. "Poor federal leadership on critical infrastructure protection"
11. "Emergency ad hockery"
12. "Policing during emergencies"

From the problems identified, one can see that disaster preparedness methodologies have applications in Canadian communities. The following sections will discuss emergency management in Canada. Section 2.5.1 provides an overview of the management system in Canada. Sections 2.5.2 and 2.5.3 cover the application of emergency management for two Canadian coastal communities, Charlottetown, PEI and Isle Madame, NS, respectively.

2.5.1 Structure of Emergency Management in Canada

Emergency response in Canada adheres to a bottom up system, where individuals are responsible for their own safety. Once the individual's response capabilities have reach its full potential, the local government is called upon, or in most cases first responders as administered by the local government. The system gradually evolves if response efforts required exceed the current capabilities (Public Safety Canada, 2011b). The graduated response model is adapted by provincial and territorial EMOs, an example is seen in the Nova Scotia Emergency Response Plan (Nova Scotia EMO, 2012, p. 16):

"Nova Scotia adheres to the graduated response model for emergency management. The responsibility begins with individuals and families in their need to mitigate and prepare for the effects of an emergency for at least the first seventy-

two hours. The responsibility then falls to the local level (municipalities) who maintain emergency management organizations, poised to bring the resources of the community into place to manage the consequences associated with any emergency”

To ensure that Canada has a harmonized approach to emergency response, federal policies from all ministries also adhere to the graduated response model. The Federal Policy for Emergency by Public Health Agency Canada states that “the responsibility to deal with emergencies is placed first on the individual and then successive levels of government are brought in as resources and expertise are needed” (Public Health Agency of Canada, 2006, p. 3).

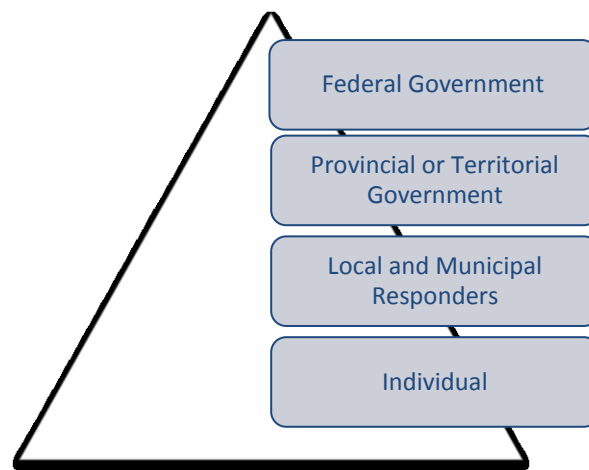

Figure 2-8 Hierarchical structure for emergency management responsibilities in Canada

The bottom up approach places individuals in a position to initiate emergency response, and for this reason the Canadian public should be well-informed of:

1. The roles and responsibilities of emergency response in Canada.
2. What is the Canadian government system capable of in terms of responding?
3. What can Canadians expect from their government at all three levels - municipal, provincial and federal?

These are questions that Canadians should know the answer to in order for them to be confident in their government and for them to feel safe in their community. Unfortunately, this

is not the case and Canadians are often not informed. This is an issue that stems from the structure of emergency management in Canada. It was recently highlighted in the 2008 Senate Report: Emergency Preparedness in Canada, and specifically in problem numbers (Canada Senate, 2008).

1. Lack of emergency management
2. Hidden emergency caches
3. Poor collaboration amongst governments
4. Emergency public communications

Issues with the structure of the emergency response system were again mentioned in the 2009 Fall Report of the Auditor General of Canada. The report highlighted several issues relating to the lack of roles and responsibilities in the Federal Emergency Response Plan and the capabilities required for an integrated response plan (Canada Office of the Auditor General, 2009, p. 2):

“Public Safety Canada has taken the first step by developing the interim Federal Emergency Response Plan, which it considers to be final although it has not been formally approved by the government. Nor does the Plan include updated or completed definitions of the roles, responsibilities, and capabilities needed for an integrated, coordinated approach to emergency response.”

As shown in the Senate and Auditor General’s Reports, there are resources and responsibility gaps in the Canadian response system. The remainder of this section attempts to bring light to these issues and present the structure of emergency management in Canada, stemming from the Emergency Management Act and moving down to the community level.

2.5.1.1 Emergency Management Act

In 2007, federal ministers along with premiers of the provinces and territories decided on a comprehensive all-hazard approach to emergency management. The Emergency Management Act was created in 2007 to provide the Minister of Public Safety the general responsibility of “exercising leadership relating to emergency management in Canada”

(Government of Canada, 2013). More specifically and in the context of the structure of emergency management in Canada, the Minister is responsible for (Government of Canada, 2013):

1. “Coordinating the Government of Canada’s emergency response operation”
2. “Coordinating the Federal government’s emergency management activities with those of the provinces and through the provinces, those of the local communities”
3. “Coordinating the delivery of assistance to the provinces in need when requested upon. These provisions are in excess of providing financial aid and coordinating the use of Canadian Forces for aid. Assistance should only be provided to the province if
 - a. The emergency declared is of concern to the federal government
 - b. The Minister is authorized to provide assistance
 - c. The province has requested assistance”
4. “Establishing policies and programs to enhance emergency management practices”
5. “Provide training and education for emergency management”
6. “Promote a common integrative approach to emergency management and adopting best practices”
7. “Promoting public awareness”

2.5.1.2 Governance Structure of Emergency Management in Canada

The Senate report, as published in 2008, criticized the emergency management system in Canada for a lack of collaboration amongst government levels. Emergency planning and management at the federal level has excluded provincial, territorial and municipal governments from the discussion (Canada Senate, 2008). The lack of collaboration led to an inadequate and inefficient response system. Figure 2-9 is compiled, based on several reports (e.g., the federal emergency response plan, provincial EMO documents and the National Emergency Response

System), to show the governance structure for responsibilities in Canada (Nova Scotia EMO, 2012; Public Safety Canada, 2011a; Public Safety Canada, 2011b; Public Safety Canada, 2011c).

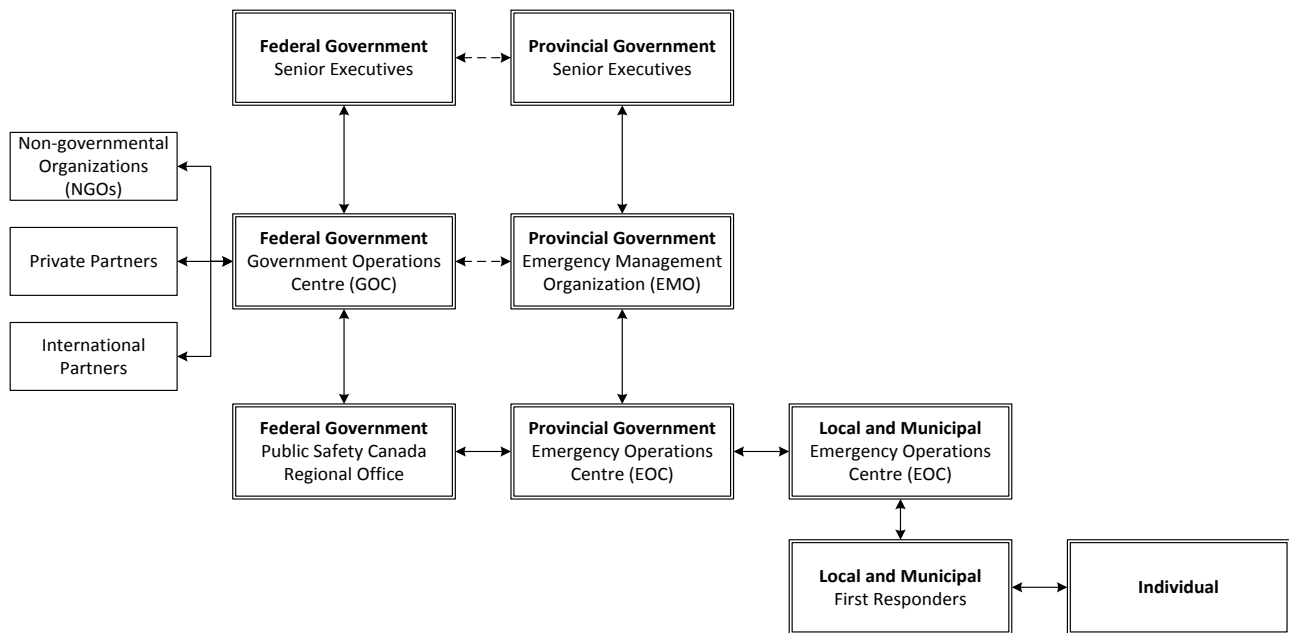

Figure 2-9 Governance structure of emergency management in Canada

The following two Sections 2.5.2 and 2.5.3 present two Canadian coastal communities vulnerable to the effects of sea level rise – Charlottetown, PEI and Isle Madame, NS respectively.

2.5.2 Coastal Communities – City of Charlottetown, P.E.I.

The City of Charlottetown is the provincial capital of Prince Edward Island, located on the southern shore of the island. The city boasts a rich history that dates back to when it was first incorporated as a town in 1855. Today, with a population of 34,562 residents (2011 census), Charlottetown is the centre of industrial and commercial activity in the province (C-Change, 2011a).

The tourism industry is most prominent in the region and is most strong during the summer months when tourists flock the city for cultural events. Culturally the city is known for its numerous summer festivals that include a Jazz and Blues Festival, Festival of Lights and The

International Shellfish Festival. Historically, it was the gathering place for the Charlottetown Conference in 1864 that ultimately led to the Canadian Confederation (C-Change, 2011a).

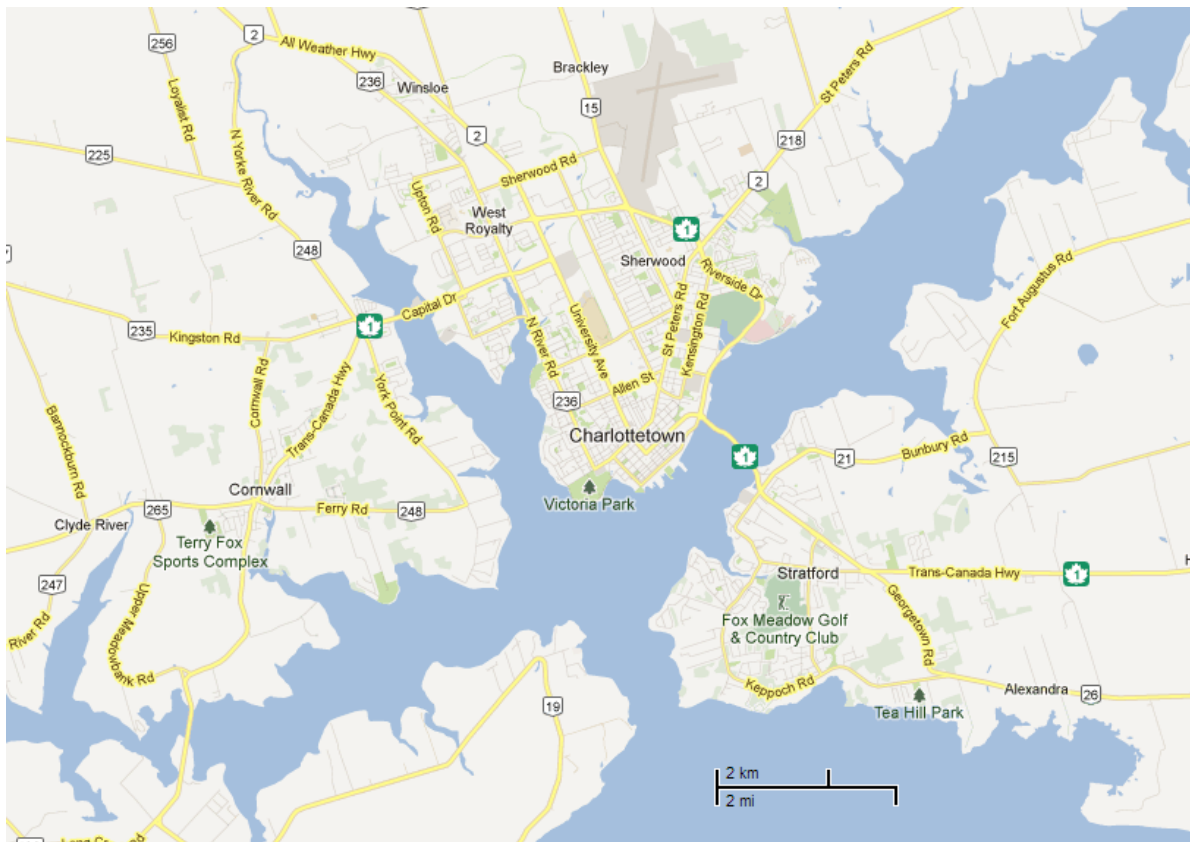

Figure 2-10 Map of Charlottetown, Prince Edward Island. Source: Google Maps (2014)

Geographically, the city is situated on the Charlottetown harbour forming a rough V-shape pointing south. The harbour opens into the Northumberland Strait and is constrained by the North (Yorke) and the Hillsborough (East) Rivers to the west and east. Aside from being surrounded by waterways, Charlottetown has an impressive amount of green space and parks (approx. 400 acres). They provide residents and tourists with many passive or active experiences depending on their interests (C-Change, 2011a). A map of the city is shown in Figure 2-10.

As a coastal community along the eastern seaboard, Charlottetown is directly vulnerable to the effects of sea level rise. In recent years storm surges have taken its toll on the city by means of floods, large waves, and coastal erosions. In some cases, sea ice formations have

damaged infrastructures. These are explicitly observable forces. Sea level rise has also caused well contamination in many communities along the coast.

Hurricane Juan in 2003 was considered to be one of the most damaging hurricanes to have hit the East Coast in recent memory. Juan made landfall onto the shores of Nova Scotia as a category 2 storm in September 2003 with sustained winds of over 213 km/h. The hurricane moved across Nova Scotia into Prince Edward Island knocking down millions of trees and causing major flooding that damaged homes, businesses and left hundreds of thousands of residents without power for nearly 2 weeks. The storm was responsible for 8 deaths and \$100 – 150 million in damage (Environment Canada, 2012).

In 2012, Hurricane Igor hit the eastern seaboard with winds of 140 km/h and rainfall of more than 200 mm. It caused widespread flooding and power outages in many communities along the coast. Water damaged homes, businesses, harbours and caused several major roads to close including the Trans-Canada Highway. There was one reported death and damage was pegged at \$65 million by the Insurance Bureau of Canada and non-insured costs were estimated to be \$120 million (Environment Canada, 2012).

It is evident through literature that the changing climate has made Charlottetown more vulnerable to the potential effects of sea level rise.

2.5.3 Coastal Communities – Community of Isle Madame, N.S.

The island community of Isle Madame is home to 2644 residents as of 2011 (Government of Nova Scotia, 2013) and is located on the South-Eastern side of the larger Cape Breton Island. The community is jurisdictionally part of Richmond Country in Nova Scotia and is separated from the mainland of Cape Breton by the Lennox Passage. Isle Madame itself is composed of three main communities, Isle Madame, Petit de Grat, and Janvrin's Island (C-Change, 2011b).



Figure 2-11 Map of Isle Madame, Nova Scotia. Source: Google Maps (2014)

Historically, it has been an important port for cod fishing in the region. Today, the fishing industry still remains as a significant employer with a snow crab plant in Petit de Grat and the international fisheries operation of Premium Seafoods, Ltd. in Arichat. The island was first settled by France and was presumed to be named after Madame de Maintenon, the second wife of King Louis XIV. During the Seven Years' War many Acadians took refuge in the region. Acadian families were able to establish roots in the region and form a large French community. Today, Isle Madame can boast a rich blend of culture and a unique bilingual style (C-Change, 2011b).

As an archipelago community connected by causeways and bridges on the eastern seaboard, Isle Madame is vulnerable to the effects of sea level rise and specifically to storm surges. In August of 2009, Hurricane Bill struck the eastern coast of Nova Scotia causing up to 58 mm of rain and 32,000 Nova Scotians were left without power after 80 km/h winds were recorded (Environment Canada, 2012).

2.6 Summary

There are many methods and approaches to defining preparedness. This section provides a summary of the key issues behind emergency preparedness as examined in the previous sections and identifies what is important for this thesis.

Frameworks for preparedness at different organizational levels were reviewed in section 2.2. At the international level, the Hyogo Framework for Action presented a broad overview of the concepts behind preparedness. The all-hazards all locations approach of the HFA is an indication that emergency preparedness is an international issue and should be incorporated into local response plans to allow for interoperability. A prime example of an interoperable operation is the IFRC's implementation of the HFA. At the national level, FEMA's Target capabilities list is a thorough definition of preparedness given their approach to the problem. FEMA identified 15 national planning scenarios as case studies to develop tasks that must be achieved to overcome the scenarios. From the Universal Tasks List, they were able to develop target capabilities required to accomplish the tasks. More specific to weather related disasters is the NWS's StormReady program that can certify communities to be StormReady if they meet the StormReady guidelines. In Canada, emergency management falls under Public Safety Canada's EMO offices. EMOs are regionally based and operated by the provincial or territorial government to address local threats. Emergency response plans developed by the EMOs for the four provinces and territories in which there are Canadian C-Change partner communities were presented. In addition to local response frameworks, preparedness can be found through collaboration planning with neighbouring communities. The IEMAC allows for member jurisdictions to request the aid of another member given that all financial costs are reimbursed after the event of need.

Measures of preparedness are generally shown as indicators – a quantitative or qualitative identifier to monitor the state of preparedness. These indicators are referred to as a checklist approach if they are presented as a set of indicators. On the other hand, attempts have been made at weighing and normalizing indicators to create an aggregated measure or

index of preparedness. The RAND Corporation presented the concept of a response reliability of the overall response system to measure preparedness.

Training and evaluation are vital steps towards being prepared. Emergency situation simulation and modelling is often used to forecast weather events and provide responders with risk free training opportunities. The SLOSH and GEM models are weather prediction models commonly used in North America for forecasting. MEOPAR is in the process of developing prediction methods to reduce Canada's vulnerability and exposure to marine emergencies. A simulation gaming exercise is used by the UN/ISDR for public educational purposes. The Stop Disaster simulation game enables players to construct more resilient communities given a budget and the community is tested against extreme weather forces. Simulation is an important tool for responder training due to the risk free environment it provides. The ADMS simulation program developed by the Environmental Tectonics Corporation uses 3D-CAD models to place responders in realistic situations training.

In smaller communities, a large scale customized high-tech simulation program is not allows a viable option. For this reason, table-top exercises are often used for responders to discuss and validate response plans given a mock scenario. Emergency Management Ontario has published documents instructing communities on how to create these training exercises. FEMA has table-top exercise packages that can be presented at the community level that includes mock videos to present the scenarios. Of the C-Change community provinces, PEI has an exercise attached to their Emergency Management guide that should evoke discussion during training.

The need to be prepared for a changing climate is evident and many efforts have been made by all levels of government to address such issues. The Canadian Government's Emergency Management Act was established to strengthen emergency preparedness and management in Canada. The Canadian coastal community of Isle Madame, NS is used as the case study for this research.

3 Methodology

This study examines the questions of what it means for coastal communities to be prepared for severe storms and what prescriptions are required to improve preparedness. In an effort to answer these questions, a methodology is proposed in this chapter to define storm surge preparedness and response in coastal communities and to evaluate its effectiveness. Several pre-existing tools and literature findings from the literature review of Chapter 2 are integrated with a proposed simulation table-top exercise for one of the C-Change community applications to evaluate the community's severe storm preparedness and response.

The methodology presented in this chapter is a mixed methodology that stems from an interdisciplinary approach. The mixed methods approach combines qualitative and quantitative methods to address the research questions presented in Chapter 1 (Tashakkori & Teddlie, 1998). The mixed methodology framework will employ elements from design science as well as community based participatory research. Design science research involves the development of innovative artifacts (i.e., systems design methodology) and the analysis of the artifact to understand and improve the system (Hevner et al., 2004; Vaishnavi & Kuechler, 2013). A component of the framework requires for a table-top exercise to be conducted and therefore elements of community based participatory research are observed.

Initially, in this chapter, the components of preparedness specific to coastal communities are defined. Definitions are followed by the methodology to creating a preparedness classification table to classify systematically the characteristics of preparedness and develop a comprehensive list of indicators relevant to coastal communities. The methodology to designing a phased table-top exercise is presented in Section 3.3. Section 3.4 proposes the use of decision trees to evaluate the dynamics of decision making under uncertainty during storm events. A process simulation methodology is discussed in Section 3.5.

3.1 Defining the Components of Preparedness and Response

Preparedness is often defined by indicators, a quantitative or qualitative identifier to monitor the state of a process. As noted in Chapter 2, organizations have attempted to develop a baseline count of the resources required to be prepared. This method produces a tangible inventory list of the equipment and supplies required in the time of a disaster (e.g., the number of fire trucks, police officers and vehicles, water level monitoring sites, and shelters). In defining preparedness from another perspective, communities and organizations point to their development of response plans, often comprised of guidelines, frameworks, plans or protocols for response.

Without actually deploying the system, a list of the correct tools (resources) and the instructions (emergency response plans) can be prepared for an emergency situation. Once an emergency event occurs, decision-makers are tasked with deciding how to respond and how to apply the resources and response plan. Questions arise regarding how decision-makers deal with the situation, the stress involved, and the time constraints. In the case of an emergency, numerous events may occur at the same time to deplete the supplies and occupy equipment. Degrees of panic or inexperience may cause the responders to improvise and deviate from the plan. The plan may also ask for decision making and this becomes a crucial part of the outcome. The point at which the community at risk should declare a state of emergency is a prime example of decision making. For the reasons mentioned, a third component of preparedness lies in how the decision-makers deploy the available resources and plans.

Another factor, that can only be examined once the system is in practice, is the reliability of the system and how effective it really is. This component of preparedness is often examined in hindsight of the disaster. Events can arise during the response operation that interrupt the process. Examples of these events are seen in ambulances breaking down after flood water enters the engine, a road leading to a vulnerable site washes out, or the communication system is disrupted. These uncertain events can occur despite a high level of

available resources, well-conceived plans and effective decision making. For this reason, system reliability is seen as a fourth component of preparedness.

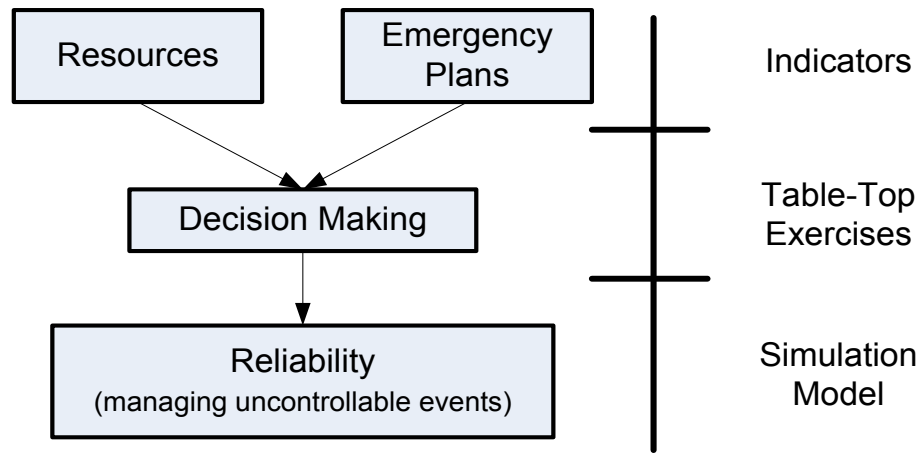

Figure 3-1 The components of emergency preparedness and response and how they will be addressed

Figure 3-1 illustrates the four components of preparedness and response and how this study will address each component. The methodologies for developing indicators, designing a table-top exercise and constructing the simulation model are presented in the following sections of this chapter.

3.2 Indicators of Preparedness Specific to Coastal Communities

A classification of preparedness is constructed from the approaches and frameworks literature. This classification ensures that the characteristics used for developing indicators relevant to severe storms and storm surges in coastal communities are collectively exhaustive. Construction of the classification structure involves an understanding of the intentions and goals of each approach and framework. The elements are categorized in the classification table shown in Table 3-1 based on the characteristic they aim to address. Overlaps in the preparedness approaches and frameworks are identified and consolidated into an exhaustive list of characteristics of preparedness. The characteristic names selected for Table 3-1 were chosen based on their use in literature reviewed. Within the context of this study resources refer to elements of emergency response plans that address physical resources (e.g., inventory system, distribution methods).

The characteristics of the classification table (Table 3-1) serve as the definition to the question of what it means for coastal communities to be prepared specifically for severe storms and storm surges. From the characteristics, coastal community specific indicators are formulated to portray the static elements of preparedness. Indicators are quantitative or qualitative identifiers designed collectively to monitor and compare the state of community preparedness.

Given the plethora of approaches and the characteristics they bring, there is a need to be selective and reclassify the descriptions into a hierarchy of preparedness. As part of the process to determine what it means to be prepared for coastal communities, a collectively exhaustive set of indicators is formulated from the literature frameworks and Table 3-1. A three level hierarchy is used for this process and the indicators are represented by the third level. The second level is attributes of preparedness and the first level is the dimensions of preparedness (Figure 3-2). Figure 3-2 is used to the three levels of the hierarchy. The full hierarchy can be seen in Table 4-2. The sample dimensions, attributes and indicators in the hierarchy structure will be discussed later on in Chapter 4.

Once the indicators have been identified and classified into the hierarchy, metrics are developed to score the indicators. The metrics use one of five scaling methods: (1) checklist, (2) fuzzy measure, (3) presence-absence, (4) intervals, and (5) proportions. The checklist approach presents a list of items that would be expected to be seen, and community scores are based on the number of items addressed. A fuzzy measure in this study implies a scale that is based on qualitative measures (e.g., good, average, and poor) or an estimation of a time frame (e.g., daily, weekly, and monthly). Presence-absence is a binary measure of either having the aforementioned item or not. The interval scale splits the measure up into bins (intervals) and depending on the where the community stands, scores are assigned by one of the intervals. The final measure of proportion is often the percentage of community members who are active in an activity.

Table 3-1 Classification table for the characteristics of preparedness as defined by the approaches and frameworks literature

Approaches & Frameworks	Characteristics of Preparedness							
	Resources	Action Plan	Deployment Logistics	Infrastructure Governance Leadership	Monitoring Training Testing Maintenance	Engagement Participation Education	Communication Collaboration	Social Services / Humanitarian Support
NWS – StormReady (NOAA, 2004)		-Formal hazardous weather operations plan		-Visits and consultations with NWS	-Water level Monitoring -Training for spotters	-Weather safety talks	-Communication -Warning systems -EOC	
FEMA – TCL (FEMA, 2007b)	-Critical Resource Logistics and Distribution -Medical Supplies Management	-Planning	-Risk Management -On-Site Incident Management -EOC Management -Evacuation and Shelter		-Information Gathering and Recognition of Indicators and Warning	-Community Preparedness and Participation -Volunteer Management	-Communication -Intelligence and information sharing -Public Info and Warning	
UN – HFA (UN/ISDR & UN/OCHA, 2008)	-Emergency Services and Stand-by Arrangements -Resource Allocation and Funding	-National institutional and Legislative Framework -Contingency Planning -Recovery Planning	-Holistic Approaches and Preparedness	-Coordination at the Local, National, Regional, and International Level	- Capacity-Building and analysis -Hazard Monitoring, Forecasting & Early Warning		-Information Management and Communication	
PEI EMO (PEI Office of Public Safety, 2013)		-Developing a municipal emergency plan		-EOC Management structure and responsibilities			-Crisis Communications	-Emergency Social Services
IEMG – IEMAC (IEMG, 2013)							-Collaboration between jurisdictions	

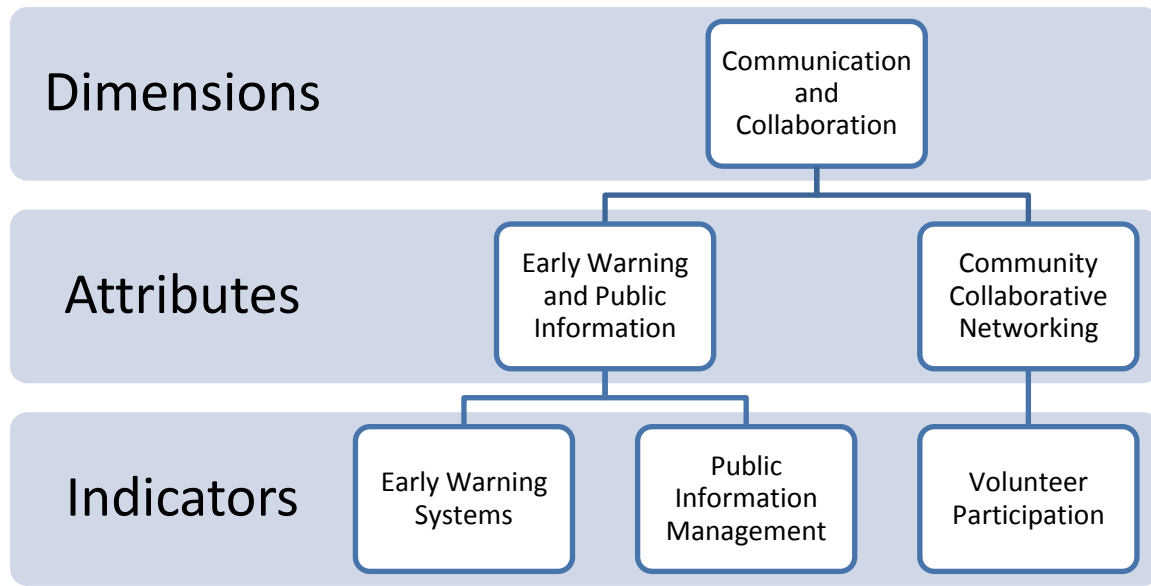

Figure 3-2 Sample preparedness hierarchy showing the three levels: dimensions, attributes, and indicators. Each indicator contains a metric designed to evaluate the indicator and assign a value-based score.

When designing indicators several factors are taken into account to insure that they are effective in the long run. These factors include (O'Leary, 2004; UN/ISDR & UN/OCHA, 2008):

1. **Clarity:** Ambiguity in defining indicators can result in varied and undesired outcomes.
2. **Cost-effectiveness:** Indicators must be realistic in terms of cost and their outcome can justify their investment.
3. **Comparability/Measurability:** Indicators should be designed with the ability for comparison over time. The measurability allows for easy identification of progress and improvement.
4. **Relevance:** Realistic and sensitive to the system in which the indicators are intended to signify.
5. **Reliability:** The indicator must be reliable to provide a basis for confident decision making.
6. **Practicality:** The information required for the indicator can be obtained in a reasonable amount of time and at a reasonable cost.
7. **Validity:** The indicator must be effective in measuring its target

Methods from the analytic hierarchy process are employed to develop weights for the indicators. A pair-wise comparison is conducted and the following section discusses the analytic hierarchy process.

3.2.1 Analytic Hierarchy Process

The Analytic Hierarchy Process (AHP), developed by Thomas Saaty, is a widely used model for multicriteria decision problems with quantitative and qualitative data (Saaty, 1990). This method is suited for this study because the indicator scores are both quantitative and qualitative inputs.

Pair-wise comparisons form the basis for the AHP model and with the help of these comparisons one can compare the criteria and alternatives with respect to each criterion. Within the framework of indicator development, each indicator is compared with all other indicators in its group to determine its importance relative to its parent attribute. A preference scale (Table 3-2) is used to quantify the importance of one indicator over another in its group. The numerical values from the preference scales are normalized to produce weights for each indicator (Stevenson, 2010).

Table 3-2 Preference scale for AHP pair-wise comparisons. Source: Stevenson (2010)

Preference Verbal Statement	Numerical Scale
Equally preferred	1
Equally to moderately preferred	2
Moderately preferred	3
Moderately to strongly preferred	4
Strongly preferred	5
Strongly to very strongly preferred	6
Very strongly preferred	7
Very strongly to extremely preferred	8
Extremely preferred	9

There are many software packages developed over the years to analyse the AHP model. *Expert Choice* was chosen for its ability to simplify the calculations and compute the weights following comparisons. This research uses *Expert Choice* (*Expert Choice Inc.*, 2004) to:

1. Input indicator scores,
2. Convert them to utility values with the help of built in utility function options,
3. Conduct a pair-wise comparison using AHP's nine point pair-wise comparison scale to develop weights, and
4. Aggregate the weights and utility scores to form an index of coastal community preparedness.

3.3 Table-Top Exercises

The table-top exercise to evaluate the situational and decision making components of community preparedness and response is aimed at community level responders. In this section, the processes of designing, developing, conducting and evaluating the table-top exercise are discussed. Given the tools developed from earlier methodologies, the concepts of preparedness and modelling are applied to the response training exercises. The following section presents the methodology for exercise design as presented by Emergency Management Ontario (2009). The framework for exercise design in this study borrows from elements of the Emergency Management Ontario approach.

Emergency Management Ontario suggested five phases of building an exercise. The five phases are shown in Figure 3-3. It should be noted that these five phases, as mentioned in this section, are not the five phases of the storm to be presented in Chapter 5. Creating a foundation for the exercise in Phase 1 includes identifying a planning team, scheduling meetings with the community to be studied, establishing project timelines and determining the availability of resources to design and implement the exercise. At this stage it is important to establish needs and requirements of the user.

In the second phase, design and development, objectives are identified and scenarios are developed. Exercise objectives should define the specific goals of the community, provide a framework for scenario development and provide evaluation methods. Objectives should be limited to enable the design of a reasonable scenario. A scenario is selected to provide the backdrop to the exercise, however the scenario should not be so challenging that it overwhelms

the exercise participants. Scenarios should be hazard specific, realistic, plausible and challenging (Emergency Management Ontario, 2009).

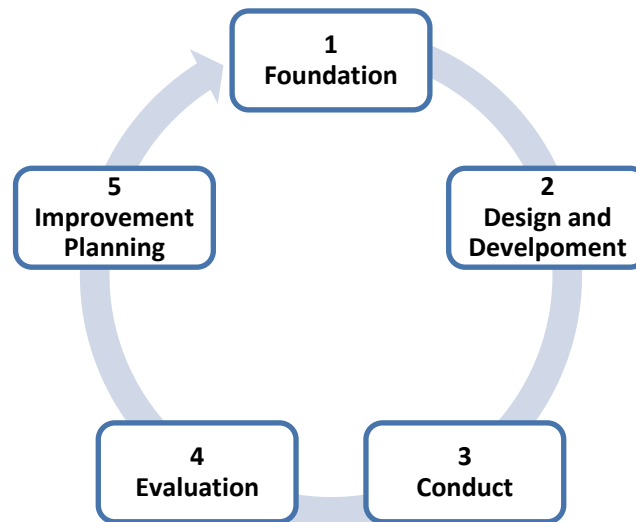

Figure 3-3 Emergency Management Ontario's phases of table-top exercise design and implementation.
Source: Emergency Management Ontario (2009)

The third phase of the table-top exercise building is to conduct the exercise and includes setup, briefing, and facilitation. In an exercise of larger scales where the public may be involved, everyone must understand the difference between what is real and what is simply for training. There must be call off signals in the event that responders are required to abandon the exercise and respond to a real situation (Emergency Management Ontario, 2009).

Evaluation is the fourth phase and the corner stone to any table-top exercise. Evaluation methodology identifies strengths and weaknesses in existing plans and is the first step to improving preparedness. The seven steps of table-top exercise evaluation as identified by Emergency management Ontario are (Emergency Management Ontario, 2009):

1. Plan and organize the evaluation
2. Observe and collect data
3. Analyze the data
4. Identify improvements and corrections that need to be implemented
5. Develop an After-action Report based on input from participants
6. Conduct a meeting to debrief the After-action Report

7. Finalize the After-action Report

The final phase is improvement planning and requires follow-up activities that include a corrective action plan or an improvement plan. The corrective action plan should identify shortfalls during the exercise and actions required to address these short falls. In this phase, the lessons learned from the exercise are converted to measurable steps that can be prescribed to improve preparedness.

3.4 Process Definition and Dynamics with Uncertainty

The reliability component of emergency preparedness and response compels responders to manage uncertain (i.e., chance) events that can occur during the process. These events will occur regardless of a high level of resources, well-conceived plans or informed decision making. The use of decision trees to model the process is presented.

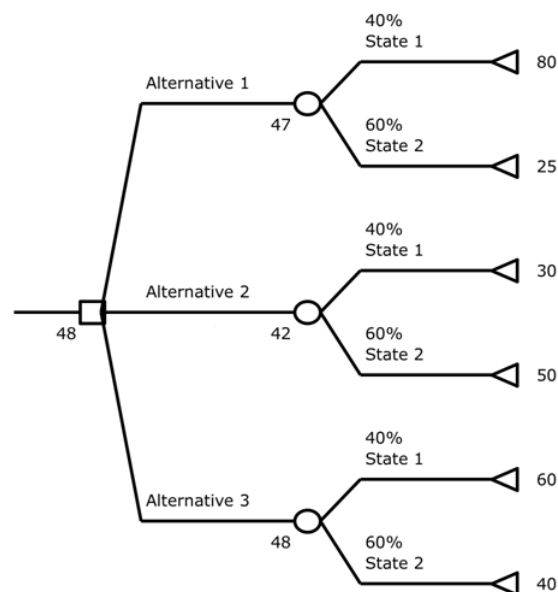

Figure 3-4 Sample decision tree structure with arbitrary values for the state probabilities and outcomes. Source: Stevenson (2010)

Decision trees are a decision support tool that describes decisions by a series of decision alternatives (squares), uncontrollable chance events (circles), and terminal values or expected value outcomes (triangles) to model possible decisions and the outcomes associated with the decision (Raiffa, 1968). Figure 3-4 illustrates a basic decision tree where the decision node on

the left presents three alternatives. Once an alternative has been selected, one is confronted with a discrete probability distribution that models the eventuality of the occurrence of States 1 and 2. The decision model assumes that the sets of alternatives and the sets of states at each node are mutually exclusive and collectively exhaustive for every decision and chance node. As such, decision and states must be clearly defined. Finally, it is assumed that only one decision is taken at each decision node, and only one state occurs at every chance node.

The decision tree is applied to decision making in the EOC for this study. A sample decision tree is presented in the following section. The decision tree/response process will commence with the storm event followed by the responder decision. As shown in Figure 3-5, several storm types can be generated and these are given as S11, S12, S13. The decision tree process presented shows up to three different storm types. They can differ based on atmospheric pressure, radius of maximum winds, location, direction and forward speed. Depending on the storm type and impacts it may carry, responders are required to make an initial decision. Decisions can be facilitated by the emergency response plan, and the dynamically changing inventory of resources available. The indicators will define what the community responders are capable of doing to mitigate the storm effects.

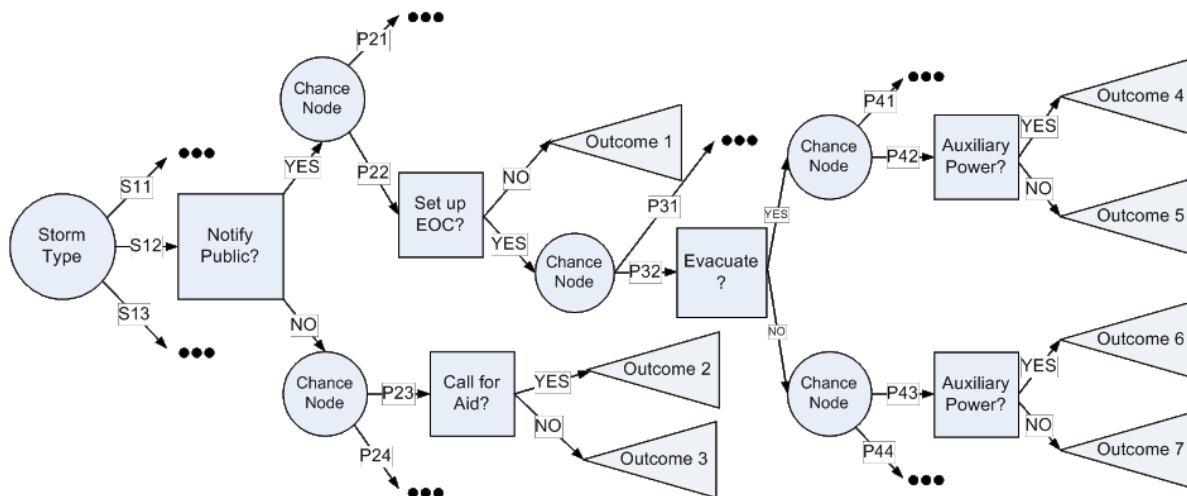

Figure 3-5 Decision tree framework applied to decision making in the EOC during storm events

The first decision required in Figure 3-5 is to decide whether to notify the public. Once a path is chosen, a chance event will occur and the responders are forced to make a second

decision. The second decision in the sample tree is either to set up an EOC or to call for help, depending on the previous paths taken. The decision tree model alternates between decision and chance nodes. This process continues until the objective of the response mission is accomplished or the storm has ended.

Once the storm has ended the simulation provides an expected value of damage for the storm. These values are for the exercise simulation purpose only and may not reflect reality. They enable the responders to compare between decisions made or not made in the process.

In an effort to create a general framework for severe storm table-tops in coastal communities, an inductive approach is proposed. By creating scenarios for specific, contextual cases one can gain a generalized concept of the framework after numerous cases have been examined. Through the process of integration, one may develop a simulation process that incorporates a comprehensive list of possible decisions and scenarios. This methodology is a valuable tool for information sharing in between communities.

3.5 Process Simulation

The table-top exercise and decision trees are constructed using Rockwell *Arena* Simulation software (Rockwell Automation, 2012). *Arena* is a discrete event simulation and automation software developed by Rockwell Automation (Kelton et al., 2007). Using the built in probability distribution functions, the simulation model is constructed to address uncertainty in the timing of the response operation as well as the arrival of uncontrollable storm events.

The simulation program of this research walks responders through a series of events where decisions and storm events dictate the outcome and the next stage of the simulation in the same way that the table-top exercise presents alternative narrative problem situations that are put to the EOC members for their discussion and proposed action.

The responders at the table-top simulation exercise must work together and navigate through the storm surge simulation by selecting the appropriate branch of the decision tree. Decision making in the time of an emergency can be stressful due to inexperience and time

constraints. This exercise allows responders to review thoroughly their decision criteria and test it against a simulated program.

A best-decision route can be charted based on the expected values at the end of the table-top using the standard decision tree analysis. However, in practice, the best decision route cannot always be selected due to the inherent interconnected probabilistic nature of the elements involved. The uncontrollable storm events and uncertainty in the response time requires responders be creative in navigating the decision problems at each stage.

This exercise that simulates actual storm events spurs discussion and allows responders to discuss decisions at each stage. For that reason, best-decisions are situation dependent. After running the table-top simulation model several times, the characteristics of an operational “best-decision” can be recorded. Gaps in emergency response plans can be identified through a table-top discussion and guidance on situational decision making can be added to the plan.

3.6 Summary

A mixed methodology approach was employed for this thesis. Methods of evaluating the four components of preparedness were proposed (Figure 3-1) using the methodologies from design science and community based participatory research.

The resources and emergency plans are assessed using indicators of preparedness developed from a classification table and hierarchy approach. A suite of storm preparedness indicators specific for coastal communities are developed using the characteristics identified from literature. A hierarchical framework and weights are developed using the indicators and management science methodologies. The decision making during storm events is captured through a community based participatory research methodology of a table-top exercise. Finally, uncontrollable events are incorporated into a simulation model for emergency response. The construction of the simulation model follows design science methodologies.

The following three chapters will apply this methodology to develop a framework to be used for coastal community emergency preparedness and response evaluation. Chapter 4 is the indicators of preparedness, Chapter 5 presents the table-top exercise, and Chapter 6 describes the simulation model.

4 Indicators of Emergency Preparedness

One of the major obstacles in emergency preparedness at the local community level is the application of a measurement tool to quantify resources and identify the thoroughness of emergency plans (O'Leary, 2004). In this chapter, emergency preparedness is measured and quantified by indicators. Indicators are not direct measurement of preparedness performance, but rather they act as a proxy to describe the community's state of preparedness (DeVellis, 1991; O'Leary, 2004). Gaps in community preparedness (i.e., emergency plans and resources) can be identified through indicators. Indicators of preparedness are developed using a hierarchical approach and metrics to capture preparedness in coastal communities. These indicators address the scope of this research by focusing on the specifics of coastal community preparedness from the impacts of severe storms, sea level rise, and storm surges at the local community level.

The following 12 approaches and definitions of preparedness are used to create a hierarchical structure of what it means to be prepared.

1. International – United Nations Hyogo Framework for Action: Disaster Preparedness for Affective Response (UN/ISDR, 2005; UN/ISDR & UN/OCHA, 2008)
2. International Collaboration – International Emergency Management Group: International Emergency Management Assistance Compact (IEMG, 2013)
3. National U.S. All-hazards – Federal Emergency Management Agency: Target Capabilities List (FEMA, 2007b)
4. National U.S. All-hazards – National Planning Scenarios (United States, Department of Homeland Security, 2006)
5. National U.S. Hazard Specific – National Weather Service: StormReady Program (NOAA, 2013)
6. National Canada – Federal Emergency Response Plan (Public Safety Canada, 2011b)

7. Provincial Canada East – Emergency Management Office Nova Scotia: The Nova Scotia Emergency Response Plan (Nova Scotia EMO, 2012)
8. Provincial Canada West – Emergency Management BC: British Columbia Flood Response Plan (Emergency Management British Columbia, 2012b)
9. Provincial Canada West – Emergency Management BC: All-Hazard Plan (Emergency Management British Columbia, 2012a)
10. County – Municipality of the County of Richmond Emergency Plan (Municipality of the County of Richmond, 2013)
11. University Community All-hazards – University of Ottawa and Carleton University (Carleton University CUSERT, 2013; University of Ottawa, 2013b)
12. University Community Hazard Specific – University of Chicago Flood Response Plan (University of Chicago, 2014)

The approaches range from an international perspective, by the United Nations, that includes developmental goals (UN/ISDR, 2005), down to the municipal level that includes phone numbers of individuals involved in the response operation (Municipality of the County of Richmond, 2013). The approaches cover all-hazards and hazard specific definitions of preparedness, as seen in the StormReady Program (NOAA, 2013) and FEMA's Target Capabilities List (FEMA, 2007b). Table 4-1 shows the range of preparedness scopes and objectives used to develop coastal community preparedness indicators for this research.

University emergency preparedness methods are reviewed for this study due to a resemblance in size between a university community and several communities in the C-Change Project (C-Change, 2011b; University of Ottawa, 2013a). Universities generally have a well-defined management and governance structure where roles and responsibilities are clear. Resources are generally available or can be brought in with less politics involved. It should also be noted that participation in emergency response at educational institutions tend to be top down and bottom up, students are actively involved in the campus community.

Table 4-1 Classification of the 12 numbered preparedness approaches reviewed into categories based on their scope and objectives. The numbers refer to the approaches itemized above.

		Objectives		
		Natural Hazards	Other Hazards Explicitly Shown	All-hazards / Integrative Approach
Scopes	International	1		2
	National	5	4	3, 6
	Regional (Provincial)	8		7, 9
	Local	12		10, 11

At the University of Ottawa, students can register their phone numbers to be alerted of campus emergencies (University of Ottawa, 2013b). Figure 4-1 shows a mobile screenshot of the alert text message sent during a testing procedure. Carleton University in Ottawa has a student volunteer program called the Carleton University Student Emergency Response Team (CUSERT). CUSERT provides first aid services at university events and 24 hour on call emergency medical first response (Carleton University CUSERT, 2013). The system in place at universities can prove to be valuable to smaller communities hoping to improve their emergency response as well.



Figure 4-1 Mobile phone screenshot of the University of Ottawa's uOttawa Alert System

The hierarchy of indicators contains three levels: the dimensions, attributes and indicators of preparedness (Figure 3-2). The levels are chosen by observing and classifying elements of preparedness as defined by other approaches. The dimensions were derived from the classification table for the characteristics of preparedness. However, for simplification, not all characteristic categories as seen in Table 3-1 were used. Due to the scale of the communities of study the indicators dimensions were simplified and reduced to 5. The 5 dimensions were selected based on judgement of how they may fit and span the notion preparedness. This method is not absolute and there may be other classification structures that capture preparedness for the effects of sea level rise in coastal communities. The dimensions of preparedness are:

1. Communication and Collaboration
2. Monitoring and Forecasting
3. Training, Education and Community Awareness
4. Emergency Services and Operations
5. Local Governance and Social Services

Attributes are created for each dimension, and within each attribute, several indicators are selected. These attributes and indicators are chosen because they can be collected in small scale operations. A hierarchy of the indicators is summarized in Table 4-2.

A value-based metric is created for each indicator with the help of five different scaling methods: (1) checklist, (2) fuzzy measure, (3) presence-absence, (4) intervals, and (5) proportions. The value-based scoring method is presented in detail for each indicator starting in Section 4.1. A summary of the indicator score analysis can be found in Appendix A – Indicator Score Analysis.

The values gained from the metrics are normalized onto a scale from zero to one, using utility functions, for comparative analysis purposes. The utility functions can be found in Appendix A – Indicator Score Analysis we well. Appendix C – Community Preparedness

Questionnaire Results provides a sample of indicator value-based scoring and utility scores for the C-Change partner community of Richmond County, NS.

The pair-wise comparison generated the weights for the indicators as found in Figure 4-2. An overview of the pair-wise comparison methodology can be found in Chapter 3, Section 3.2.1. The weights are subjective and are based on the values of the author in this scenario. The framework for the derivation of weights remains the same for all cases. However, depending on the group of communities being study, the weights can be adjusted to meet the values and needs of the communities of interest. For example, communities in given region (i.e., province) may use different weights than the communities of another region.

The weights and utility scores developed from the hierarchical structure for the indicators enable researchers to calculate an overarching preparedness index. However, the index only serves the purpose of comparison between communities and has no real value for this study. Of interest to this study is the hierarchical structure. The structure enables researchers to conduct gap analyses to compare the actual performance of the system to the potential or ideal state of the system. The structure also paves the way for a sensitivity analysis to be conducted. The richness in this approach is found in the hierarchical structure and enables better opportunities for analysis than a simple index value.

The following sections of this chapter discuss the individual indicators and how they are derived. Most indicators are presented with an example of a community that currently has implemented some form of the indicator. The example scores are based on the community's capabilities as observed from internet sources. These examples are used to illustrate how the indicator metric is applied and may not be an accurate representation of the community's actual indicator value.

This chapter is organized into the hierarchy, of Figure 4-2, formulated with dimensions, attributes and indicators as the three levels of text provided below.

Table 4-2 Hierarchy of emergency preparedness. The dimensions are listed in the first column. Each dimension has two to three attributes (shown in the columns to the right). Each attribute carries with it, one to four indicators.

Dimensions	Attribute 1	Attribute 2	Attribute 3
1. Communication and Collaboration	Early Warning and Public Information i. Early Warning Systems ii. Public Information Management iii. Populations at Risk	Community Collaborative Networking i. Volunteer Participation ii. Social, Cultural and Faith-based Groups	
2. Monitoring and Forecasting	Data Collection and Management i. Data Collection ii. After-action Review Process	Environmental Forecasting i. Weather Forecasting Means ii. Trained Public Spotters	Hazard and Vulnerability Analysis i. Infrastructure Safety Audit ii. Public Safety Contact Line iii. GIS Flood Mapping and Simulation Analysis
3. Training, Education and Community Awareness	Capacity Building and Planning i. Simulation Exercises ii. Community Emergency Plan	Public Awareness i. Household Preparedness ii. Public Outreach	
4. Emergency Services and Operations	Incident Command System i. Incident Command System	Emergency Operations Centre i. Emergency Operations ii. Planning for Infrastructure Maintenance	Resources i. Inventory System ii. Maintenance iii. First Responders iv. Shelters and Evacuation
5. Local Governance and Social Services	Preparedness Budget i. Budget Allocation ii. Donation Management	Jurisdictions i. Joint Meetings ii. Audit of Activities iii. Judged Orientation iv. Committees of the Whole	Humanitarian and Mutual Aid i. Crisis Counselling ii. Mutual Aid Program

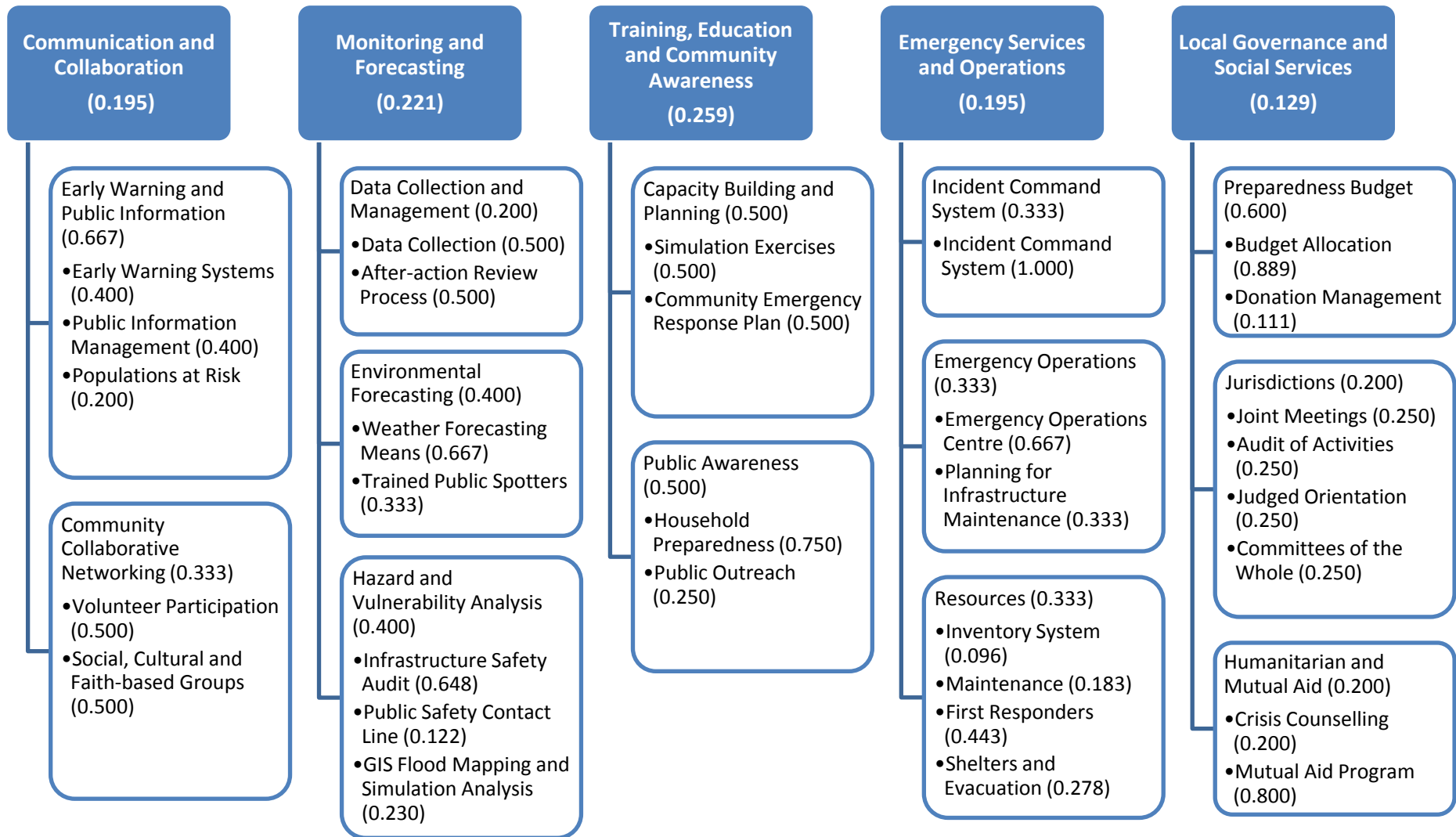

Figure 4-2 Hierarchy showing the weights derived from a pair-wise comparison for the dimensions, attributes and indicators of preparedness

4.1 Dimension 1 - Communication and Collaboration

The communication and collaboration dimension of emergency preparedness captures the flow of information and networking aspect that can enhance preparedness. Attributes found under this dimension are early warning and public information and community collaborative networking.

4.1.1 Early Warning and Public Information Attribute

Early warning and public information refers to how the public can be alerted of pending storm conditions and how they are informed throughout the process. A prepared community would have multiple means of information dissemination to initially alert and continuously inform the public.

The benefits of providing early warning enables people to flee from hazardous areas, allows people to protect their property and most importantly take shelter. The benefits of early warning are not only limited to public interest, but also those involved in the response operation once the storm hits. For example, reservoir operators can gradually reduce water levels to accommodate the influx of surge water or precipitation, responders can position emergency equipment, and aid agencies can mobilize sooner in an effort to be more prepared for the pending storm (Rogers & Tsirkunov, 2010).

Early warnings have shown to substantially reduce damage and lives lost during severe weather events. For example, the best course of action during a tropical cyclone in Hong Kong is to shelter in one's own house or apartment. Strict building regulations in Hong Kong have ensured housing and infrastructure improvements that can be used as shelter during extreme weather events (Jacks et al., 2010). Early warning systems are used in Hong Kong to ensure that the public has time to return to their place of shelter. The system in Hong Kong follows a number scale and the warning escalates as the threat becomes more severe. Standby Signal No. 1 is issued whenever a tropical cyclone is within 800 km of the territory. Signal No. 3 and 8 are issued to warn the public of strong and gale force wind respectively, while Signal No. 10 warns of hurricane force winds. The public is encouraged to return to their place of shelter once a

Signal No. 8 has been issued. Interestingly enough, a sense of societal responsibility has evolved in Hong Kong as well. Once Signal No. 8 has been issued business and schools will close to ensure that everyone can return home safely (Jacks et al., 2010; Rogers & Tsirkunov, 2010).

Examples of warning systems include cable television audio or video overrides, local radio stations, outdoor warning sirens, cell phone messaging, or even visiting houses door-to-door. A prepared community would have access to multiple systems in case one or more fail or is proven to be inefficient at alerting all members of the public. For example, a television override message would not be very effective in the middle of the night. Multiple early warning systems provide responders with different options to disseminate the message depending on the situation.

A well-constructed warning system not only alerts the public of pending danger but also articulates on the threat and invokes action. Articulation must include the mode of communication, the threat, and the actions required.

The evaluation of early warning systems is done with the help of a checklist approach. The top four methods as seen in emergency response plans are radio message, television, cell phone messaging and door-to-door notification. In this system, the presence of an early warning system is worth twice as much as the articulation or action communicated by the system. For example, communities with three functioning early warning systems that do not articulate on the threat or provoke an action is given a rating (rating = 6) greater than a community that only has one warning system and articulates on threat and action (rating = 4).

Communities will receive a score of 2 for every system they have. If they have systems other than the mentioned four, they will receive an additional 2 for the unmentioned system. Articulation of the threat can be evaluated in the same manner for each system. Where articulation is present, a score of 1 is awarded, and 0 for absent. The same can be said about whether a course of action is provided in the warning message. The maximum score is 20, while the minimum score is 0. The scaling method for the score is subjective and is based on the author's values and perception.

Based on the proposed method, Hong Kong has an indicator score of 12. The early warning scale as mentioned before is broadcasted over the radio, television and internet as shown in Table 4-3 (Hong Kong Observatory, 2014). All three forms articulate on the pending threat and the action required to be taken.

Table 4-3 Early warning systems checklist for Hong Kong, CN

System	Presence-Absence	Threat	Action
Radio	✓	✓	✓
Television	✓	✓	✓
Cell Phone			
Door-to-door			
Other	✓	✓	✓

Communication with the public is not only required during the early warning stages but also throughout the event. Having the capabilities to keep the public involved and informed during and after the storm is an integral part to being prepared. Those directly impacted by the storm may wonder how much longer before power can be restored, where the hazardous areas are, and how the storm is developing. Members of the community may have friends or family members they are concerned about and would like to be informed of the situation as it develops. Another example is to relay information onto those who may provide help through donations or physically volunteer.

The ability to broadcast information effectively during the storm event will heavily rely on a strong relationship built with local media outlets. Therefore the indicator for public information management is constructed using a checklist and a fuzzy measure. Four recommended methods for information dissemination are suggested and communities are asked to classify themselves with respect to the frequency information is disseminated through the five listed sources. The fuzzy measure and scoring value for each method is as follows – ongoing (3), hourly (2), daily (1) and not available (0). The maximum score in this case is 15 while the minimum is 0. Table 4-4 presents the indicator score (score = 9 = 3x3) for the community of Victoria located in British Columbia Canada.

Table 4-4 Public information management indicator score for Victoria, CA

Public Information System	Ongoing (3)	Hourly (2)	Daily (1)	N/A (0)
Radio	✓			
Television	✓			
Cell phone messaging				
Website	✓			
Other				

Elders, young children and those with disabilities are often most at risk in a storm. A cell phone messaging system would not be very efficient for reaching elders who are less proficient with technology. Those who suffer from visual or auditory impairment are often left behind in a system that does not take these issues into consideration (McElroy, 2013).

During Hurricane Sandy in 2012, New York City Mayor Michael Bloomberg’s televised press conferences featured a sign language interpreter, Lydia Callis. Her presence during the press conference was a breakthrough for emergency management, a field that often overlooks the challenges faced by those who are disabled (Duke, 2012). New York Times described her presence as “She not only was able to translate the important words of the mayor to anxious viewers across the country but also provided clear, coherent and animated explanations to millions of deaf and hard-of-hearing Americans” (McElroy, 2013). The importance of being prepared to address a sub population’s needs is shown with the impact of having a sign language interpreter.

For this indicator, a community is awarded a score of 1 for every subpopulation that the early warning system reaches and an additional score of 1 for every subpopulation that the public information system reaches. The subpopulation groups used in this indicator are based on the needs that a well designed system should address. The purpose of the subpopulations is for emergency management personnel to evaluate community systems. Individuals may fall under more than 1 subpopulation and individuals are not asked to identify themselves using the subpopulations.

The subpopulation of special concerns refers to cases such as hearing impairment, visual impairment, mobility issues and many others. Community officials generally have an understanding of the special needs of their community.

An example of the scoring for New York City (score = 10) is shown in Table 4-5.

Table 4-5 Populations at risk indicator score table for New York City, US

Sub-populations	Early Warning System	Public Information
School Age	✓	✓
Young Adult	✓	✓
Adult	✓	✓
Seniors	✓	✓
Special Concerns	✓	✓

4.1.2 Community Collaborative Networking Attribute

Community collaborative networking is an attribute that captures the social capital in the community. A tight knit community is more likely to be prepared than one that is not. This attribute measures how involved community members are in their own community and how likely they are to know and help their neighbours. When social barriers are broken and neighbours are comfortable with each other, a sense of preparedness in the community has increased (Koh & Cadigan, 2008).

In 1995, Kobe Japan was struck with an earthquake that measured 7.2 on the Richter scale. The number of casualties was upwards of 6,400 people, while 200,000 people were left without homes and had to find temporary shelters. Infrastructural damage was extensive and within the City of Kobe alone, 70,000 buildings had collapsed and 55,000 were severely damaged. The estimated damage was tagged at 7 trillion JPY or 70 billion CAD (Nakagawa & Shaw, 2004).

During the reconstruction phase, “Machizukuri” (Town Development) organizations were formed in different city zones. A “Machizukuri” comprised of community residents, private agencies and any others who have an interest in the zone’s restoration following the

earthquake. These community groups were mostly formed on the basis of pre-existing neighbourhood associations. The “Machizukuri” provided neighbours with an opportunity to discuss restoration plans and community preparedness for emergency events (Nakagawa & Shaw, 2004). The case of Kobe Japan showed that a community with high social capital, formed through neighbour outreach and networking, is more likely to recover and also be prepared for future events than a group with low social capital.

For this attribute, two indicators are developed: volunteer participation and social, cultural and faith-based involvement. For both indicators, a proportion scale is used to measure the proportion of community members who are involved in the mentioned activities. A score ranging from 1 to 5 is awarded depending on which interval the community falls in. These two indicators follow the same score assignment distribution as shown in Table 4-6.

Table 4-6 Score assignment for community collaborative networking indicators

Score	Proportion interval
1	0% - 20%
2	21% - 40%
3	41% - 60%
4	61% - 80%
5	81% - 100%

The volunteer indicator measures the percentage of population that is involved in at least one volunteer opportunity. Examples of volunteer opportunities in coastal communities can include volunteering at a local school, a medical clinic or a hospital.

Social and cultural and faith-based organizations offer individuals an opportunity to network and become acquainted with their neighbours. This indicator measures the percentage of individuals who are actively involved in at least one of these groups. Scouts, Guides, sports teams, or the Lions Clubs are examples of social groups. Cultural groups can help with emergency preparedness public outreach by delivering training in a language that is pertinent to the cultural group. In some communities, those who do not speak the predominant language

may often feel excluded, cultural groups can act as a means of communication with this subpopulation to deliver the message on community preparedness.

Following Hurricane Katrina in 2005, several faith-based organizations were the first to engage in rebuilding efforts. The Mary Queen of Vietnam Roman Catholic Church in East New Orleans was able to use a church as a headquarters for their rebuilding operation. Their efforts inspired other Vietnamese community members who do not interact with the general public as much due to cultural or language barriers to follow suite in the rebuilding effort. The operation included rebuilding and decontaminating damaged homes, preparing meals for families in need, providing temporary housing, and driving one another to church or work (Hauser, 2005; Shaftel, 2006).

4.2 Dimension 2 - Monitoring and Forecasting

An integral part to being prepared is to be able to monitor situations and forecast future events. These activities will provide communities with the necessary information to be properly prepared. Attributes found under this dimension are: (1) data collection and management, (2) environmental forecasting and (3) hazard and vulnerability analysis.

4.2.1 Data Collection and Management Attribute

Fortunately, storms do not happen daily but when they do happen they are a prime opportunity to test out emergency response systems. Emergency response is a dynamic process and systems can always be improved upon, and for this reason proper collection of data and analysis enables communities to develop best practices. This attribute captures the activities necessary to acquire the information and to develop best practices from it. Data management is shown to be a key component of preparedness planning as described in the fifth priority of the UN's Hyogo Framework for Action (UN/ISDR & UN/OCHA, 2008). By contributing to a database of information containing storm behaviour, response process and damage, responders are increasing their capacity to predict and model future storms and response operations. This attribute contains two indicators, data collection and after-action review process.

Data collection promotes financial and end-user accountability throughout the response process and in order to be prepared for future events, collection methods must be established and tested. This activity enables responders to measure and evaluate a response system under real conditions. Therefore, procedures should be in place to document the storm for post-storm review and promote ongoing learning for the community (UN/ISDR & UN/OCHA, 2008). A prepared community will have the capability and procedures to execute data collection during the storm event.

The indicator for data collection is divided into three sections for the three types of data that can be collected: weather, response, and damage. Each data type is graded based on how often information is collected. The grades for each type are continuously (3), hourly (2), daily (1), or not available (0). The maximum value is 9 while the minimum value is 0. An example of data collection post flood is found in the Hydrate Project's initiative. The Project is founded by the European Community to advance methods of flash flood forecasting. The researchers on the project collected data from Danube, Rhine, Rhône and Tyne river basins following flooding in the area. The information is used to improve knowledge of the flood process and develop best practices for the regions affected (Bain et al., 2010).

Collected data needs to be analyzed post-storm and developed into best practices to promote ongoing learning. This process ensures that storm emergency response data are used to build upon a foundation for emergency response in the community. After-action reviews are mentioned in FEMA's Target Capabilities List (FEMA, 2007b) and Nova Scotia's Emergency Response Plan (Nova Scotia EMO, 2012).

Following Hurricane Katrina, the community of Lincoln Nebraska prepared an after-action review that identified strengths and weaknesses in the community's response as well as recommendations for future events (Nebraska Urban Search and Rescue Task Force One, 2005). The same was seen in Halifax following Hurricane Juan in 2003. A post-storm debriefing was conducted and lessons learned were noted along with future recommendations, such as

improved use of resources and people, operational protocols, and communications (Nova Scotia EMO, 2003; Nova Scotia EMO, 2004).

If a community has an after-action review process where data collected from the storm are analyzed for the development of best practices and then implemented they are awarded a score of 2. Communities that develop best practices but do not take the initiative or due to political reasons have difficulties in implementation are awarded a score of 1. While if an after-action review process is not available, a score of 0 is noted.

4.2.2 Environmental Forecasting Attribute

The changing climate brings more unpredictable weather patterns. The ability to better forecast such weather events is crucial in terms of being prepared for a storm surge. Communities are better prepared if they have a reliable weather and water level forecasting system (World Bank, 2008). With increased reliability and means of monitoring the weather, community members can be confident in their local government's early warning system. The two indicators found in this attribute are weather forecasting means and trained weather watchers/spotters.

Communities vulnerable to the effects of sea level rise and climate change are upgrading their weather forecasting and monitoring capabilities through the help of the international community. In 2010, the ambassador of Finland to the Caribbean Community (CARICOM) pledged to support the CARICOM in improving its resilience to natural disasters through the development and implementation of technologies that will provide real time information on approaching hurricanes (Caribbean Community Secretariat, 2010). The same approach was seen on the other side of the world in Sri Lanka, where the Korean government donated a data reception and analysis network valued at 2 million dollars to upgrade Sri Lanka's forecasting capabilities (Prevention Web, 2012)

Communities should have a variety of locally owned and operated weather monitoring equipment. Local weather forecasting equipment increases forecasting reliability relative to the community and also the speed of acquiring weather information. Decision making in the EOC

can depend on local forecasts as opposed to waiting for Environment Canada to update on current and pending weather conditions. The closest Environment Canada monitoring station could be a fair distance away and may not be as relevant to the community.

The StormReady program suggests the use of anemometer (wind gauge), rain and river gauges, and locally owned weather radar. Aside from the three types mentioned, StormReady also suggests acquiring information through an internet or television radar (NOAA, 2004). For this reason the weather forecasting indicator uses a fuzzy measure to evaluate how recently equipment has been updated for the three types of equipment listed. The scores assigned by the fuzzy scale are within the past year (3), within the past five years (2), within the past ten years (1) or not available (0). The Philippines Department of Science and technology has installed automated weather monitoring stations at a local school in Bangued, PH. The automated monitoring system is one of several tools to be distributed to local communities as part of the country's disaster mitigation efforts (Beñas, 2011). Table 4-7 shows the application of the weather forecasting means indicator to the community of Bangued. A total score of 6 is awarded.

Table 4-7 Weather forecasting means indicator score for the community of Bangued, PH

	Within the past year (3)	Within the past 5 years (2)	Within the past 10 years (1)	N/A (0)
Wind equipment (anemometer)		✓		
Water (rain and river) gauges		✓		
Locally owned weather radars		✓		
Other				✓

Public weather spotters are an effective means for gathering micro-forecasting information and also identifying hazards as they develop in the community. Commonly referred to as ground-truthing, community weather spotters can verify what is seen on radars and report it to appropriate authorities. CANWARN and SKYWARN are the Canadian and American programs respectively for training weather spotters. In Canada, CANWARN volunteers use ham

radios to report weather conditions to Environment Canada. Information gathered from this method includes lightning, hail, cloud types, or even tornado sightings (Emergency Communications Ontario Association, 2013). In the United States, SKYWARN has over 290,000 trained spotters to assist in micro-forecasting (National Weather Service, 2013).

In some communities, hobbyist weather watchers often form groups to discuss weather related activities. These groups can be a source of information for forecasting authorities at the local community level as seen with the Nova Scotia Weather Service and their Facebook page for training public weather spotters (Nova Scotia Weather Service, 2014).

The following indicator is a checklist type indicator that measures whether community weather watchers are professionally trained, amateur watchers, or they do not exist. Professionally trained spotters are given a score of 2, amateur watchers 1, and if none are available then 0. The following table (Table 4-8) shows the assignment of indicator score of 2 for trained public weather spotters in Ontario, CA.

Table 4-8 Trained public spotters indicator score assignment for Ontario, CA

	Professional (2)	Amateur (1)	N/A (0)
Weather Spotters	✓		

4.2.3 Hazard and Vulnerability Analysis Attribute

Hazardous areas in the community that require extra attention during a storm should be identified beforehand. Responders should be aware of the hazards they face in order to properly prepare for it. Hazards and vulnerability analyses are commonly conducted to identify and address risks before they become major problems. This attribute has three indicators, they are: infrastructure safety audit, public consultations, and GIS flood mapping and simulation analysis.

Hazardous buildings, bridges, roads and other community assets that are prone to the effects of a storm should be identified so that they can be avoided in a storm. An infrastructure safety audit is commonly conducted to identify these hazardous areas (UN/ISDR, 2007). This

indicator captures when the last audit was conducted on the following infrastructure types in a community: buildings, roads and bridges, waterfront infrastructure, water management, utility lines, and any other community assets. A score of 3 is awarded if it was within the past year, 2 for the past five years, 1 for the past ten years, and 0 if an audit has not been conducted.

By identifying hazards through this method, communities can install signs at these locations to show possible flood levels or communicate the threat and action required in the event of a storm surge (UN/ISDR, 2007). The tsunami warning sign seen in Figure 4-3 is located at Grand Anse Beach in Grenada and shows the action required when signs of a tsunami are detected. Information about potentially hazardous areas can be used to distribute hazard maps. Hazard maps identify dangerous areas during a storm and can be a tool for increasing community awareness and education (UN/ISDR, 2007).



Figure 4-3 Tsunami warning sign at Grand Anse Beach, Grenada. Source: Chung (2013)

The public may be vigilant of infrastructure that requires maintenance or are of concern. Public consultation meetings can aid in identifying these locations. Many communities have a contact line for the local EMO where residents can report hazardous sightings during a storm without disrupting the emergency telephone line. Anchorage Alaska has an emergency condition line to report hazardous situations during a storm (Municipality of Anchorage, n.d.).

Examples of what residents may report include a washed out roads, down utility lines, trees blocking routes and many other hazards that can develop during the course of a storm event. By reporting such an event to the EMO, staff at the EOC may respond accordingly.

Public consultations offer community members an opportunity to voice their concerns about hazardous areas in the community. Community members are the end user of the system and their feedback is vital for increasing community preparedness. Prepared communities will hold consultation meetings with the public to listen to address concerns (UN/ISDR, 2007).

This indicator measures how well authorities consult and communicate with the public. A score of 1 is awarded if a community has a public safety contact phone line and another 1 is awarded if public safety consultations are held.

Aside from community safety audits and public consultations, the use of GIS information to create flood maps and analysis has shown to be a useful tool to increase emergency preparedness. Low lying areas can be identified with the help of LIDAR technology and simulation studies should be conducted with this information. GIS information can be used for city infrastructure planning, emergency response simulations, flood simulations, and many others (ESRI, n.d.). The NOAA's SLOSH has shown the power GIS data for surge simulation along the US Eastern Seaboard (Glahn et al., 2009).

This indicator is used to determine whether GIS information is available for the community and if so, whether it was done recently. If the data were collected in the last five years then a score of 2 is awarded, a score of 1 is given if the information is available but is not collected in the last five years, and 0 if the information is not available. An application of this indicator score of 2 is shown in Table 4-9 for the community of Galveston, US.

Table 4-9 GIS flood mapping and simulation analysis indicator score assignment for the community of Galveston, US

	Present and < 5 Years (2)	Present and > 5 Years (1)	N/A (0)
GIS Flood Mapping	✓		

4.3 Dimension 3 - Training, Education and Community Awareness

The third dimension of preparedness focuses on community knowledge, specifically training, education and community awareness for storm surges. A population that is well trained and educated in responding to the effects of storm surges is more likely to be a prepared community. The attributes found in this dimension are (1) capacity building and planning and (2) public awareness.

4.3.1 Capacity Building and Planning Attribute

Functions that the community is capable of conducting during an emergency should be assessed and evaluated. Deficiencies can be addressed after the assessment. The indicators found under this attribute are simulation exercises and developing an emergency response plan.

Simulation exercises create an environment for communities to test out emergency response plan, assess their capabilities, and enable key decision-makers to practice their response efforts (Emergency Management Ontario, 2009). This indicator captures whether table-top or full scale exercises were conducted recently. Communities are asked to select the scenario that best describes simulation exercises in their community. A score of 2 is awarded if an exercise type has been conducted in the past 12 months, a score of 1 if the exercise has been conducted in the past but not within 12 months, and 0 if such an exercise has not been conducted. The maximum value for this indicator is 4, while the minimum is 0.

Table 4-10 Simulation exercise indicator score assignment for the community of Little Anse, CA

	Present and < 6 Months (2)	Present and > 6 Months (1)	N/A (0)
Simulation table-top exercise	✓		
Simulation full scale exercise			✓

As part of this study, a table-top exercise is conducted for the community of Little Anse in Nova Scotia. A full scale exercise has never been simulated. Therefore for this indicator the community of Little Anse would receive a score of 2 out of a possible 4, as shown in Table 4-10.

The second indicator, under the capacity building and planning attribute, calls for having an emergency response plan in place, an overarching plan that acts as the blueprint for the response process (Kapucu, 2008). Communities are asked to evaluate their emergency response plan based on two factors: how well it coordinates key players and how well it addresses the hazards and vulnerabilities of the community. A fuzzy measure scale is used to evaluate these two aspects of the emergency response plan. Communities that do not have an emergency response plan are asked to select not available and they are given a score of 0 overall for this indicator. The table below shows the value of the scores awarded depending on how communities rate their emergency response plan. The maximum score is 4 while the minimum is 0. Table 4-11 shows the indicator score applied to a hypothetical community that has weak designation of key players and strong designation of the hazards identified in the community. The score assigned for this community is 3 out of a possible 4. The subjectivity of this indicator made it difficult to provide an example of a real community.

Table 4-11 Indicator score assignment for emergency response plans of a hypothetical community

	Strongly Designated (2)	Poorly Designated (1)	N/A (0)
Coordination of key players		✓	
Reflects hazard analysis	✓		

4.3.2 Public Awareness Attribute

Public education for response is important in the graduated response system where responsibilities start with the individual and gradually expand upwards if needed. Household preparedness and the overall awareness of the community can enhance emergency response. Two indicators are found under this attribute: household preparedness and public outreach.

Household preparedness refers to the number of families in a given community that have taken on emergency preparedness measures in their homes (UN/ISDR, 2007). The types of household preparedness identified in this study are categorized into five categories: family preparedness kit, flood protection, emergency generators, flood insurance and first aid training. Communities are asked to select the proportion interval that best describes the percentage of households in their community that have these emergency measures. Scores are assigned to the community based on the interval in which they identified themselves. A maximum score of 25 is awarded when a community has at least 81% of its households partaking in each of the household preparedness categories. The minimum score is 5, where less than 20% partake in each category.

These values are generally difficult to find published, therefore a hypothetical community is used to demonstrate the scoring. The community represented in Table 4-12 achieved a score of 8.

Table 4-12 Household preparedness indicator score assignment for a hypothetical community

Household Preparedness Categories	0%- 20% (1)	21%- 40% (2)	41%- 60% (3)	61%- 80% (4)	81%- 100% (5)
Family preparedness kit - stored food, water, medical supplies, and basic commodities		✓			
Flood protection - Sewer backflow valves, water tight windows and doors, raised electrical systems	✓				
Emergency generators	✓				
Flood insurance	✓				
First aid training			✓		

The second indicator under public awareness is public outreach and refers to the effort by emergency preparedness and response organizations to educate the public on the hazards they face and the actions needed to respond. This indicator calls on communities to incorporate education on severe weather events and preparedness for it into school activities, faith-based groups and social groups. The importance of this indicator is highlighted in the StormReady program (NOAA, 2004) and UNISDR's Stop Disasters game (UN/ISDR, 2007) which is a method

of public outreach itself aimed at the younger generation. For StormReady certifications, communities are required to conduct or facilitate safety talks in institutions such as schools, hospitals and industries (NOAA, 2004).

Communities are asked to rate how often they conduct outreach to the following groups in their community: schools, faith-based organizations, and social or cultural groups, and others. This indicator uses a fuzzy measure as a scale and a score of 3 is awarded if the community evaluates its outreach weekly, 2 if monthly, 1 if yearly, and 0 if no outreach activities have been conducted for a maximum of 12 and minimum of 0 (Table 4-13).

Following Hurricane Katrina, the City of New Orleans has increased its community outreach program. As of today, New Orleans is involved in outreach projects such as (City of New Orleans, 2013):

1. NOLAReady – real-time updates on where to go, what to do, who to contact and other important information during an emergency
2. Community Emergency Response Team (CERT) – training for a volunteer response team
3. Evacuteer – training for those who want to volunteer during a city wide hurricane evacuation

For these outreach initiatives and many others mentioned on the City of New Orleans website, an indicator score of 12 can be assigned to New Orleans (Table 4-13).

Table 4-13 Public outreach indicator score assignment for New Orleans, US

	Weekly (3)	Monthly (2)	Yearly (1)	N/A (0)
Schools	✓			
Faith-based organization	✓			
Social and cultural group	✓			
Other	✓			

4.4 Dimension 4 - Emergency Services and Operations

The fourth dimension of preparedness examines emergency services and operations, planning for activities that usually take place during the response process. The attributes found under this dimension are incident command system, emergency operations, and resources.

4.4.1 Incident Command System Attribute

The incident command system attribute contains one indicator that determines whether a community has devised an Incident Command System (ICS) for emergency situations. The incident command system is an organizational structure that helps coordinate response efforts where multiple organizations are involved. This structure eases the confusions that may arise when multiple organizations with different functioning and command structures are involved in one operation (Public Safety Canada, 2011b).

This indicator follows a presence-absence scaling method, where if an incident command system is present then a score of 1 is awarded, if not then a score of 0 is noted.

4.4.2 Emergency Operations Attribute

The attribute of emergency operations refers to capturing whether a command centre exists where key decision-makers can congregate and make managerial decisions for the response operation. This attribute is represented by an indicator for the establishment and testing of the centre itself and an indicator for infrastructure maintenance planning.

Emergency Operations Centre (EOC) acts as the central command post responsible for coordinating emergency response efforts on site and is therefore crucial for any response operation. The checklist indicator has three levels: established and tested, established but not tested, or has not been established. Scores are assigned as 2, 1 and 0 respectively for the three levels.

Planning for infrastructure maintenance refers to clearing of road, fixing utility lines, water and waste management and many other tasks during a storm. This indicator asks

whether the community has plans and the capabilities to carry out such tasks. A presence-absence indicator is used and a score of 1 is awarded if they do and 0 otherwise.

4.4.3 Resources Attribute

Reliably functioning equipment that is properly inventoried and taken care of will assist with the emergency response operation. This attribute contains four indicators: inventory database, equipment maintenance, first responders, and shelter and evacuation resources.

Communities should have an inventory of their equipment and resources as well as those of private partners. The inventoried list not only includes the availability but also the name and contact information of those responsible for it and how more can be brought in if required. An example of an inventoried list of equipment can be found in the Municipality of the County of Richmond's Emergency Plan (Municipality of the County of Richmond, 2013).

This indicator for an inventory system follows a presence-absence scaling method, where if an inventory system for equipment and other resources is present then a score of 1 is awarded, if not then a score of 0 is noted.

The second indicator under resources asks for communities to evaluate how often their equipment is maintained. Communities that routinely conduct maintenance service on their equipment (e.g., generators, front end loaders, defibrillators, pumps) are more likely to have equipment that functions reliably in the event of a storm. A fuzzy measure scale is used for this indicator where the scale ranges from not available up to weekly. A score of 4 is awarded for weekly, 3 for monthly, 2 for yearly, 1 for longer than one year, and 0 if maintenance is never conducted.

The third indicator of the resource attribute is first responders. Directly above the individual in the graduated response model is first responders (Public Safety Canada, 2011c). For this study, the definition of first responders includes police, firefighters, paramedics and search and rescue personnel. They deal directly with the public and are integral to the response process. The flow of responsibilities in the graduated emergency management model includes local and municipal first responders on the critical path (Public Safety Canada, 2011c).

International comparisons show how Canada's police strength compares to other countries. In 2010, Canada's police strength (203 per 100,000 population) was 8% lower than Australia (222), 11% lower than England and Wales (229), and 17% lower than the United States (244) (Statistics Canada, 2010). Based on these numbers, this study has used the value of three police officers per population of 1000 as the benchmark for a prepared community. From the same assumption, three paramedics and three firefighters would also be used as the benchmark for a perfect score. Communities are asked to provide the number of professional first responders and volunteer responders. This value would be scaled to the population of the community and applied to a linear utility function where nine responders per 1000 people would yield a perfect score of 1. No responders would result in a score of 0.

The fourth and last indicator requires communities to have the capabilities to evacuate (transportation) and shelter (accommodation and food) the public in the event of a severe storm. Communities are asked to provide the number of shelters and evacuation vehicles that can be deployed in the event of an emergency. This study will assume that two shelters for every 1000 residents and 20 vehicles for every 1000 residents is a perfect score. The scores are assigned based on what percentage of the perfect score can be achieved. Therefore a perfect score would yield 200. This indicator has a minimum score of 0 percent.

Bangladesh is used as an example for the score assignment. Bangladesh recently highlighted to the UNISDR that the country is 2000 cyclone shelters short of where they need to be. The country currently has approximately 3000 shelters but has set 5000 as the benchmark to be prepared (UN/ISDR, 2012). The population of Bangladeshis living on the coast was not mentioned, but from the report, Bangladesh has achieved 60% of what they consider to be a perfect score.

It should be noted that these values are provided to show how the indicator score may work and may not be the actual representation of the community.

4.5 Dimension 5 - Local Governance and Social Services

The last dimension of preparedness covers the roles and responsibilities of the government and the services they provide. Local governance and social services has three attributes: preparedness funds, jurisdictions, and humanitarian and mutual aid.

4.5.1 Preparedness Funds Attribute

Local governments must budget for emergency situations given the rise in frequency and severity of storms. The preparedness funds indicator captures how communities will financially manage in preparation for the pending storm and also how they manage donations during a storm.

Aside from the normal budget that includes funding for first responders, infrastructure maintenance and many other tasks, communities of late have been asked to allocate at least 1% of their total budget for disaster risk reduction and climate change adaptation. This was put forth in the Manila Call for Action of Parliamentarians on Applying Disaster Risk Reduction as an Instrument for Achieving the Millennium Development Goals meeting in 2010 (Philippine Daily Inquirer, 2010). The Philippines has taken on the role as the United Nation's Asia-Pacific Regional champion for disaster risk reduction and climate change adaptation. In 2011, the Philippines had an annual budget of \$1.645 trillion PHP (\$40 billion CAD), and 2.72% of that amount was allocated for disaster risk reduction, that is roughly \$44.8 billion PHP (\$1.07 billion CAD) (Philippine Information Agency, 2010).

The disaster risk reduction budget indicator's scoring system follows an interval scale where a score of 1 is awarded for communities that allocate from 0% to 0.49% of their total operating budget for disaster risk reduction, 2 for 0.5% to 0.99%, 3 for 1.0% to 1.49%, 4 for 1.5% to 1.99% and 5 for more than 2.0%. In the case of the Philippines, a score of 5 would be awarded.

Budgeting for disaster risk reduction activities prepares a community for imminent storms, once a storm hits communities and social agencies often rely on donations to cope with the conditions. In order to be fully prepared, communities must have plans to handle donations

as they come in during the disaster, someone needs to coordinate donated goods, services, and money. Often, a lack of organization in management for this aspect results in a loss of time, money and resources - none of which are to spare in a disaster situation. Key aspects that should be considered beforehand include, who is responsible for accepting, controlling, issuing donation receipts, redistribution and storage of goods (Nova Scotia EMO, 2012).

This indicator follows a presence-absence scaling method, where if plans for donation management are present then a score of 1 is awarded, if not then a score of 0 is noted.

4.5.2 Jurisdictions Attribute

The second attribute of this dimension is jurisdictions, and refers to governance system and how activities are conducted in regards to emergency management. There are four indicators under this attribute: joint meetings, audit of activities, judged orientation, and committees of the whole.

Joint meetings refer to the frequency of meetings held to discuss emergency preparedness at the community level. Members of all levels of government should be present to address community hazards and develop new methods of responding to emergency situations. There are often gaps in governance between the government levels when it comes to emergency preparedness, and these gaps result in a lack of resources or poor communication at the community level during a time of need (Canada Office of the Auditor General, 2009; Canada Senate, 2008). These gaps were previously discussed as issues with the Canadian emergency management system in Chapter 2 – Literature Review. The indicator for joint meetings follows an interval scale that measures the number of joint meetings held over the past three years. If communities had between zero and one meeting over the past three years, they are awarded a score of 0, two to three meetings will give a score of 1, and four or more meetings earn a score of 2.

An audit of activities related to emergency preparedness ensures that the program is up to date with current methods and also ensures that resources and money are not wasted on none effective programs. The City of Ottawa has conducted an audit of its emergency

management program in 2006 and produced a 60 page report on the areas that need improvement (City of Ottawa. Office of the Auditor General, 2006). As seen with the City of Ottawa, an audit of activities conducted routinely is an integral part of the local government's responsibilities for emergency preparedness. This indicator is measured using a presence-absence scale where a score of 1 is awarded if an audit has been completed and 0 if not.

Emergency preparedness requires a collective approach within the community, with a proactive attitude from the top level government right down to the individual. The indicator of judged orientation evaluates the approach to response in a community to either be top-down or bottom-up on a slider scale. The ideal state is situated directly in the middle where leadership in governance is equal to the engagement of the individuals in the community (Schneider, 2011). The Canadian system uses a bottom-up approach in most cases and its drawbacks are outlined in Chapter 2 – Literature Review.

The last indicator of jurisdictions requires that communities form committees at the local government level to address the issues of climate change adaptation and disaster risk reduction. An example of an emergency management committee is seen in the governance structure of Red Deer, Alberta. In 2011 Red Deer passed The Emergency Management Bylaw to ensure that Council establish committees to address emergency situations, including the preparedness phase (City of Red Deer, 2011). For this indicator, if these committees exist, then a score of 1 is awarded and 0 if not.

4.5.3 Humanitarian and Mutual Aid Agencies Attribute

The indicator of humanitarian and mutual aid agencies contain two indicators: crisis counselling and mutual aid agreements.

The psychological effects of a disaster may take its toll on a community. Therefore, prepared communities must have supportive services for those who have been affected by a disaster. Crisis counselling post-storm may diminish long term effects on the social capital for the community. Following the floods in Colorado in the late summer of 2013, FEMA provided \$792,000 to help establish counselling for flood victims in 9 different counties. The funds were

used to hire 66 new crisis counsellors who live in the area, providing employment opportunities for those affected (Tenser, 2013). The crisis counselling indicator is a presence-absence indicator. If communities have a post-storm crisis counselling program, they are awarded a score of 1 and 0 if not.

Resources can often be shared between jurisdictions to optimize the response effort. A jurisdiction that is overwhelmed by a disaster can request the aid of neighbouring jurisdictions. These aid programs can be found at numerous levels of government. Policies and agreements in place to request aid from neighbouring jurisdictions must be constructed beforehand. These agreements must include an incident command system that can integrate the aiding responders into the operation. Concerns about cost reimbursement and liability should be discussed beforehand so that aid can be provided quickly during an emergency. Neighbouring jurisdiction's capabilities must be well understood beforehand so that the correct resources could be brought in (IEMG, 2013; Nova Scotia EMO, 2012). This indicator follows a presence-absence scaling method, where a score of 1 is awarded if an agreement has been established with at least one neighbouring community and 0 is noted if no agreements have been made.

This chapter presented the indicators used to quantify preparedness within the scope of this study. In summary, the indicators are derived from literature and a hierarchy of preparedness was constructed. A value-based metric was created for each indicator to assign a value-based score. The scores are mapped into utility functions to be normalized to a scale from zero to one. Weights are also derived for each indicator with the help of a pair-wise comparison. Given the normalized scores and weights one could form an index of emergency preparedness for coastal communities. The weights and scores can also be used for gap analyses and comparisons between communities.

Following this study, a questionnaire was sent out to the eight C-Change Partner Communities to collect this information. The questionnaire results for the Partner Community of Isle Madame, Nova Scotia can be found in Appendix C – Community Preparedness Questionnaire Results.

The following chapter presents the application of community preparedness, as determined by the indicators, to informed decision making during an emergency. A table-top simulation framework is presented along with a case study of decision making in the emergency operations centre for the breakwater failure in the community of Little Anse, Nova Scotia.

5 Emergency Response Table-Top Exercise and Analysis

A successful emergency response operation must have the resources and plans to respond (preparedness), well informed decision making (response), and also the ability to manage uncontrollable events in the system. This chapter focuses on the decision making aspect during emergency situations and employs the use of a table-top exercise to simulate and evaluate decision making. Table-top exercises are used as a means of enhancing community awareness, validating plans, and/or assessing response capabilities.

A discussion of the table-top exercise and the framework for its design is given in Section 5.1. Section 5.2 presents the exercise facilitation guide for the coastal community of Little Anse, a C-Change partner community as part of Isle Madame, Richmond County, Nova Scotia. This table-top exercise is a case study application of the framework introduced in Section 5.1. Section 5.3 provides a critical analysis of the table-top exercise conducted in Little Anse. This section discusses the strengths and weaknesses of the framework as well as gaps in response operation for the community of Little Anse, Nova Scotia.

5.1 Table-Top Exercise Design

Table-top exercises and their designs are discussed below. Section 5.1.1 summarizes the table-top exercise conducted as part of the Basic Emergency Management Course offered by Emergency Management Ontario at York University on January 15, 2014. Section 5.1.2 introduces the use of phases and detailed events in design to address hazards identified by the community hazard analysis.

5.1.1 York University and Emergency Management Ontario Workshop

Emergency Management Ontario offers a Basic Emergency Management Course (EM200) (Emergency Management Ontario, 2010). The course acts as an introductory overview of the emergency management system in Ontario. The course covers topics of preventing, mitigating, preparing for, responding to, and recovering from emergencies and disasters. The course contains an element that requires participants to participate in a table-top exercise.

The exercise observed on January 15th, 2014 was catered specifically for York University and therefore the scope of the exercise was centred on an event that would occur at York University. The incident presented was a fire in a resident building that slowly moved over to engulf the chemistry and security building as well. Emergency management personnel in the EOC included many senior managers from York University as well as the manager of the Emergency Preparedness program who was facilitating the exercise.

It was difficult to gauge the level of emergency preparedness of York University as a system and how the University navigates through the response process as a whole. It should be noted that individuals were well-informed of the tasks that they were required to do, but this study is interested in the response of the system, and not necessarily that of an individual. The table-top exercise was used in this sense to spur discussion among exercise participants and clear-cut answers or decisions were not necessarily the goals. This study therefore requires a revised and more structured table-top exercise that will enable exercise evaluators to identify more specifically how emergency responders navigate through the decisions of an operation collectively.

Given a more structured approach, analyses can be conducted on the decisions and best practices can be developed.

5.1.2 Structure

Emergency situations modeled as table-top exercises are often left with an open ended discussion for participants to identify gaps qualitatively. This section presents a set of phases for EOC decisions to provide structure to the discussions of the table-top exercise. A more tangible table-top exercise will enable EOC members to gauge the effectiveness of best practices and identify the gaps in strategies that require further attention.

Each phase of the table-top exercise contains several detailed events. The detailed events present a discussion opportunity for the series of decisions to be made during the emergency. The phases and detailed events are developed from the hazard analysis provided by the community to ensure that the correct hazards have been addressed. Hazard analyses are

a systematic methodology for identifying threats that need to be addressed. A large scale storm, for example, may trigger several different hazards (e.g., hurricane, flood, power outage, and water pollution). In most cases, these hazards arise concurrently and therefore procedures for an effective response must be in place. Hence, the reason for constructing a table-top exercise that addresses the response procedures required for the threats identified. It is rare that one will see a hurricane where a power outage is not observed. This form of systems integration provides a realistic analysis of the emergency response procedure.

The Richmond County Emergency Response Plan (2013) has identified 16 hazards as *very likely* and *nearly likely* to occur. These 16 hazards range from natural (e.g., hurricanes) to man-made (e.g., oil spills). Within the scope of this study and the exercise to be conducted, detailed events are created to address 12 of the 16 “very likely” and “nearly to occur” hazards.

The following section presents the exercise facilitation document for the case of a severe winter storm in the coastal community of Little Anse, NS.

5.2 Phased Table-Top Exercise Facilitation Guide

The facilitation guide, provided to the exercise facilitator, includes an introduction to the framework, narratives, facilitation notes, and phase and event descriptions. The PowerPoint slides used to conduct the May 1, 2014 table-top exercise are found in Appendix D - Presentation Slides for Table-Top Exercise Facilitation.

This exercise is developed and conducted as a collaboration between the Canadian Red Cross, Northern Nova Scotia and Cape Breton Districts, the C-Change ICURA Project (International Community-University Research Alliance), and the Municipality of the County of Richmond (MCR).

The table-top exercise was reviewed by the Office of Research Ethics and Integrity at the University of Ottawa and it was determined that ethics approval was not required for this exercise.

This exercise facilitation guide and analysis (presented in the following section) are case studies used to demonstrate the phased exercise design framework. The community of Little Anse in Isle Madame N.S. was selected as the case study community due to the hazards they face (as outlined in Section 2.5.3). The table-top exercise was designed for this study but at the same time serves as a deliverable for the C-Change partner community.

This exercise takes into account a specific event and location. The scope of the table-top exercise implicates community emergency planning groups. The following list presents the scope of the exercise.

1. **Geographic Area:** Community of Little Anse and Arichat in Isle Madame, NS
2. **Hazards:** Winter storm, storm surges and flooding
3. **Participants:**
 - a. Municipal Emergency Management Personnel (i.e., Emergency Management Coordinator)
 - b. First Responders (i.e., EHS Ambulance Driver , Volunteer Fire Department Chief)
 - c. Provincial Government (i.e., Nova Scotia Community Services, Public Health)
 - d. Non-Governmental Organizations (i.e., Canadian Red Cross)
 - e. Elected Officials (ie., District Councillor)
 - f. Community Members
4. **Purpose:** The purpose of this table-top exercise is to evaluate decision making during the response process based on the capabilities and resources of the Little Anse Community.
5. **Objectives:** The objective of this exercise is for members of the EOC to apply their problem solving skills to a series of detailed problems that may arise during a storm event. Resources and capabilities dynamically change based on the previous decisions made by EOC members. For this specific case study, the EOC will navigate through the decisions required to activate an early warning system,

respond to distress calls, manage public information, evacuate those in need and many other scenarios.

5.2.1 Table-Top Narrative

This section presents a narrative for the case study of Little Anse, N.S. The section includes background information on the community, the hazards they face and a brief description of each phase that sets the stage for the table-top simulation. The case of the Little Anse Community in Isle Madame is used to present the framework for designing the table-top exercise.

5.2.1.1 Background Information

Little Anse is a coastal community of approximately 125 inhabitants located on the eastern coast of Petit de Grat Island of the Isle Madame archipelago. Isle Madame is jurisdictionally a part of Richmond County, N.S. and therefore abides to the emergency response plan developed by Richmond County. Historically, the community is an important port for the cod fishing industry and other sea trades.



Figure 5-1 Satellite bird's eye view of Little Anse, N.S. View looking south. (Bing Maps, 2013)

Little Anse Community assets can be divided into 4 categories; economic, social, cultural and environmental. Economical assets include 2093m of road surface, 100 houses, 8 outbuildings, 45 wells and a 30m wharf. Many of these physical assets can be seen in Figure 2.1. Variables that contribute to the social pillar of Little Anse include a church/community hall, community population with the majority of who are seniors, and a small youth population. Culturally the community is identified by its Acadian Catholic roots, and its historical dependence on the fishing industry. Petit de Grat Island, where Little Anse is situated, is abundant in natural capital with many trees, wetlands, lakes, and a rocky coastline.

The changing climate has caused an increase in frequency and intensity of extreme weather events occurring along the Little Anse coastal area. Coastal communities are the first in line to face such a changing environment. Little Anse faces the threat of the main road flooding due to recent failure of the breakwater, destruction of the Little Anse wharf and cutting off access to the southern part of the community. Severe storms can cause surges that will damage coastal properties, flood houses, and damage the fresh water wells. Fallen trees due to strong winds can block roads and damage power lines. For these reasons, Little Anse proves to be a viable case study for the development of a table-top exercise.

5.2.1.2 Outline of Table-top Phases

The following section presents the table-top exercise for the case of the breakwater failure in Little Anse Isle Madame. The exercise was designed as a presentation of five phases that transitions from being prepared, to responding, and then to the early stages of recovery. Each phase carries with it up to three detailed response events that will test decision making in the EOC. The following describes the ordered phases of the table-top exercise (Table 5-1).

1. **Storm Hits** – The start of this phase marks the beginning of the emergency and is the transition from preparedness to response as described by Public Safety Canada.
2. **Breakwater Fails** – The aging breakwater fails and storm tides are able to carry its force into the mooring area.

3. **Power Outage** – Strong winds and rain causes trees to topple knocking out power for the community in this phase.
4. **Community Flooded** – Surge levels rise and water inundates many homes along the coastal area forcing individuals to retreat to higher elevations.
5. **Salinization of Water Sources** – In this phase, the effects are longer term but still require a response. This phase is the transition into recovery as defined by Public Safety Canada.

Table 5-1 Phases of the table-top exercise and description of detailed events

Phases	1	2	3	4	5
	Preparedness / Response	Response	Response	Response	Response / Recovery
	Storm Hits	Breakwater Fails	Power Outage	Community Flooded	Salinization of water sources
Detailed Events	Activate EOC	Respond to fallen tree damaging house and power lines	Respond to car washed off road	Evacuate community	Provide social services and counselling at the shelters
	Alert community	Respond to media request for information	Respond to heart attack victim	Respond to woman and her two children left behind	Address public health issues from flood water
		Respond to child who has not returned home	Contain hazardous materials in flooded weld shop		Respond to criticism from community and media members

5.2.2 Phases and Detailed Events Facilitation Notes

This section describes the detailed events, facilitation notes, and discussion questions for the facilitation of the table-top exercise. A brief a narrative of each phase is presented, followed by the detailed events of each phase. The detailed events contain a short narrative - and a series of questions designed to invoke discussion regarding decision making.

5.2.2.1 Phase 1: Winter Storm Hits

It is just past 6pm on Wednesday January 22nd and Environment Canada has issued a winter storm warning for most of Nova Scotia as a low pressure system is developing south of

the Maritimes. Heavy snowfall, freezing rain and strong winds are forecasted for the area of Isle Madame.

In the past, communities in Isle Madame were heavily affected by severe storms and concerns about storm surges and floods are widespread when a low pressure system with strong winds is in the forecast.

The storm has moved into the region and driving conditions are extremely poor. The snow from earlier in the day has turned into freezing rain, and heavy rainfall is expected to last overnight. Strong winds of well over 110km/h can be felt and storm tides are battering the coast. Several community members have voiced their concern for their safety on social media websites.

The screenshot shows the Environment Canada website's weather alert page. At the top, there are logos for the Government of Canada and the Government of Nova Scotia, along with navigation links for Canada.gc.ca, Services, Departments, and Français. The main header includes the word 'Weather' and the 'Canada' logo. A search bar is located on the right. Below the header is a navigation menu with options: Weather, Alerts, Marine, Air Quality, Analyses and Modelling, and Past Weather. The main content area is titled 'Alerts for: Richmond County' and includes the following text:

Richmond County
6:38 PM AST Wednesday 22 January 2014
Winter storm warning for Richmond County continued

Significant snowfall, freezing rain, blowing snow and winds expected today, tonight and Thursday morning.

This is a warning that dangerous winter weather conditions are occurring in the region of Richmond County. Monitor weather conditions and follow for updated statements.

An intensifying low pressure system developing south of the Maritimes will track northeastward passing east of Nova Scotia tonight before reaching Newfoundland Thursday morning. This disturbance will bring significant snowfall that will turn into ice pellets and freezing rain.

Freezing rain over Isle Madame is expected to persist overnight for another 5 to 6 hours, with freezing rain changing to rain over Eastern Isle Madame early morning. Rainfall accumulations of 30 to 40 millimeters are forecast by Thursday morning. Strong southwesterly winds are expected to develop overnight with gusts between 80 and 110 km/h.

Figure 5-2 Screenshot of the exercise's Environment Canada's weather warning. (edited: Environment Canada, 2014)

Activate Emergency Operations Centre

Given past storms and the devastation they have left, the community is apprehensive about the situation. At 9:30pm the Municipality of the County of Richmond has decided activate their EOC in Arichat. Questions arising regarding EOC activation include:

1. Who is authorized to activate the EOC? When should the EOC be activated?
2. What level of activation is needed for the given situation? Who would be involved at this level of activation?
3. Where should the EOC be situated? Are there alternative locations?

Alert Community

An hour has passed since the activation of the EOC and responders have been monitoring the storm as it moves towards the region. At this point, this winter storm has been deemed to cause significant damage as seen with the communities in Southern Nova Scotia that are currently in the midst of the storm. It is now close to 10:57pm and the areas facing significant risks should be alerted. There have been reports of large chunks of ice battering the breakwater in Little Anse and it could break any moment now. The following discussion questions are raised:

1. When and how should the community be notified? Should a state of emergency be declared (keep in mind continuity of operations)? Who is responsible for this?
2. Who are the media partners? Are there scripted messages or templates to ensure the necessary information is delivered? If not, please provide a sample message for the given situation.
3. What other organizations would need to be notified at this stage of the storm?

5.2.2.2 Phase 2: Breakwater Fails (Roads Flood)

Shortly after midnight, the breakwater gives out after hours of being battered by strong winds and storm surges. Wind gusts of 120km/hr combined with the low atmospheric pressure brought on by the storm causes storm surges to reach a height of 1m. The onrush of water into the cove washes out the road and several homes along shore. The main road leading into Little

Anse is no longer accessible trapping residents in the community. At this point, an EOC has been established and the community has been warned of the imminent danger.

Respond to Fallen Tree Damaging House and Power Lines

At approximately 1:05am dispatch received a distress call from a residential house located on Morrison Drive. Strong winds and wet snow have caused a tree to topple onto a corner of the house, wiping out the power lines in the process. There is at least one casualty when the tree took out a corner of the house. Neighbours are currently attending to the injured elderly woman - however she needs medical aid immediately.



Figure 5-3 Satellite map of Little Anse, N.S. (Bing Maps, 2014)

The road leading into the community is flooded and alternative routes or methods must be determined to reach the victim. Time is of the essence now that the breakwater has given out and water levels are unpredictable as storm surges move in. Questions posed include:

1. Who is needed to respond to this event (restoring power, securing the area, alerting the community to avoid the area, removing the tree)? What type of equipment will need to be deployed?
2. How will emergency triage be carried out?
3. How will those affected be able to withstand the cold weather without heat in a damaged home? Will a generator be provided or will they be evacuated? (If evacuated, where can they go?)

Respond to Media Request for Information

Members of the media (Telile, The Hawk, CBC Radio, The Reporter, Cape Breton Post, and St. Peter's Cable) have been pressing the EOC for more information on how the storm is developing as well as the response efforts. A sense of panic can be felt amongst the community members as they express their concerns through social media and phone calls to the radio stations. In fear of letting the situation get out of hand, a media centre or method of information dissemination needs to be set up. The following questions need to be addressed:

1. Where should the media centre be set up?
2. Who is responsible for addressing the media?
3. What information should the public be aware of at this point in time?

Respond to Child Who Has Not Returned Home

It is now 1:20am and dispatch has received a call from panicked parents about a missing child. A 15 year old girl, who was going to spend the night at her friend's house (located on Cypers Lane), decided to head back home at around 10pm to beat out the storm but it has now been almost 4 hours and her parents have not heard from her. The parents are out frantically searching but the washed out roads have limited their search areas. Discussion on the following questions arises:

1. What organizations can be contacted to assist with this situation?
2. Should the community be alerted and if so, how will this be done?
3. What are the possibilities of organizing a volunteer search operation?

5.2.2.3 Phase 3: Power Outage

Strong winds continue into the early morning hours and heavy snow causes trees to topple and knock out the majority of power lines in the community. Little Anse is left with no electricity in freezing conditions as water creeps further up the shoreline. The washed out road is still flooded and access in and out of the community is limited.

Respond to Car Washed Off Road

At 4:10am a call came in for a car trapped on the flooded road. A man in his 70s was trying to drive further inland and out of the Little Anse side of the cove to take shelter from the storm. His car broke down on the flooded road and now strong surges have pushed the car into the brackish pond with him trapped inside. There are concerns of hypothermia if he is not rescued soon. The following questions arise:

1. Who can be deployed to respond and what equipment would be needed?
2. Who are responsible for closing off the road and alerting the community? How will the road be closed off?
3. Where can the victim be treated or transferred?

Respond to Heart Attack Victim

Immediate medical attention is needed for an elderly man suffering from a heart attack on the Little Anse Community side of the cove. These questions require addressing at the table-top exercise:

1. Who can be deployed in this situation? What resources can be used and where are they located? Are there community volunteer responders who are trained for this situation?
2. What alternative routes can be taken to reach the scene now that the road has been washed out?
3. How will the man be safely transported and to where can he be treated?

Contain Hazardous Materials in Flooded Weld Shop

Homes and businesses are flooded as the surge level increases through the night. Establishments with hazardous materials are of concern for Little Anse residents. Vernie J. Martell Welding & Industrial Welding, located near the community, has several oxy acetylene and propane tanks that could pose a threat to those in the surrounding area if they explode. This is an issue that needs to be addressed immediately before the building collapses. The following questions arise:

1. What methods can be employed to contain these tanks? Who can be deployed to carry out this task?
2. What types of equipment are required?
3. What safety measures are utilized? Should neighbouring homes be evacuated?

5.2.2.4 Phase 4: Community Flooded

High winds, waves and tides continue to lash the coastal community of Little Anse. Surge levels have reached a height of 2m and the majority of the community is flooded. Many community assets have been damaged in the process, including the entire wharf, 8 buildings, and 32 houses.

By early morning, it is evident that the Municipality of the County of Richmond is overwhelmed by the storm overnight. As the storm continues to batter the coast and flood communities up the Eastern shore line, Richmond County will need the aid of neighbouring jurisdiction. Resources are now depleted and responders are exhausted after being on the job for the past 12 hours. Tasks that still need to be completed include sheltering those left homeless, restoring power, clearing the roads, replenishing supplies and evacuating if needed.

Evacuate Community

It is now 7:02am and surge levels have reached an unprecedented height of 2m. The majority of homes have flooded and an evacuation order is issued. Conditions are no longer bearable due to the freezing temperatures, downed power lines, and flooded homes.

Discussion on the following questions is required:

1. How will community members be alerted about an evacuation order? Who is responsible for ensuring that everyone is evacuated? Is there a method to account for everyone?
2. Where are the shelters located and are they capable of handling the number of people expected to arrive? How many are expected to arrive?
3. What methods of transportation are available to evacuate community members (e.g., buses, boats, car pool)? Are community members required to find modes of transportation themselves?

Respond to Woman and Her Two Children Left Behind

Shortly after opening the evacuation centre at 7am, responders were approached by a man who said his sister is nowhere to be found. He spoke to her early last night before the telephone lines were disconnected. Due to a physical impairment it is likely that she may not have heard the evacuation orders issued. He is starting to panic and wants responders to go back into Little Anse to find her and her two young children. Consider the following discussion questions:

1. What is the best course of action to take? Should someone be deployed and if so who? What resources will they need?
2. How will responders communicate with the woman upon finding her?
3. What accommodations can be made for the population at risk during evacuation and sheltering?

5.2.2.5 Phase 5: Salinization of Potable Water Sources

The storm has died down but the aftermath is clearly visible. The storm left a path of destruction through the coastal community - claiming 3 fatalities, 7 injured and hundreds without a home. The flood water left behind has raised concerns about public health issues. Also, the community has 45 wells and 16 have been damaged by the storm. Potable water is scarce in the community and citizens are uneasy about returning home.

Provide Social Services and Counselling at the Shelters

As the morning progresses, more people check in at the emergency shelters. The majority of whom have been displaced due to the floods and some are there to check in on their friends and family. Spirits are down in the community and everyone is mentally exhausted from the overnight ordeal. Many are distraught and it is clear that they need crisis counselling. The questions below summarize the issues that need to be addressed:

1. What types of services are needed? What types can you provide as a community?
2. How will you address food, clothing, lodging, registration and information, and personal services?
3. What organizations can assist in this situation? What are their capabilities?

Address Public Health Issues from Flood Water

By noon on January 23rd, the devastation that the storm has left behind is clear. Homes were destroyed, roads were severely damaged, and key infrastructures (e.g., utility lines, water mains, and wells) were lost. A major concern now is water-borne diseases that may be present in the ocean water, including ballast water from off-shore vessels and sewage. These sources may expose the water system to common water-borne contaminants such as giardia and *Escherichia coli*. Damp, cold and unsanitary conditions make returning to the community of Little Anse unsafe. A secondary concern is the contamination of potable water sources due to saltwater encroachment. With 16 wells destroyed, potable water is scarce in the community and must be addressed before residents can return. The following discussion questions are considered:

1. What preventative measures have been discussed for this situation?
2. How will the community cope without a source of clean water for several days?
3. What measures can be taken to limit disease outbreaks from waste water and mould from the flood?

Respond to Criticism from Community and Media Members

Community members say they are furious that local government officials did not take proper precautions to ensure safety ahead of a storm that left three people dead, seven injured and many people from the community displaced. Consider the questions below:

1. What statements can be given to the media post-storm?
 - a. Things we were able to do
 - b. What our priority is
 - c. Areas of improvement that we as a community need to work on
 - d. Areas in the response system where we would be pressed for time
2. How will the community reach out to those affected?
3. How can the community develop and implement best practices for future emergency events?

5.3 Table-Top Exercise Critical Analysis

Following the Little Anse table-top exercise, participants were asked to participate in a hotwash / debriefing session. The hotwash debriefing session is a discussion between participants and members of the exercise facilitation team to discuss preliminary observations immediately following the exercise. This section provides the general feeling experienced by the participants as well as the observations made during the table-top using the phased exercise framework. The strengths and challenges of the phased table-top exercise are discussed (5.3.1) followed by obstacles and areas in which the exercise can be improved upon (5.3.2). The last section of this chapter itemizes the gaps identified during the table-top exercise. These gaps are specific to the situation in Little Anse but provide a sense of the results expected from this type of exercise.

5.3.1 Strengths and Challenges

The strengths and challenges observed during the table-top exercise are summarized in this section. Two areas of interest in this critical analysis are (1) structure and (2) participation of key members.

5.3.1.1 Structure

During the exercise participants were able to relate to the hazards mentioned in the table-top exercise. Several instances of déjà vu were mentioned, in which participants talked about how this case was seen several years prior. The cases of the lost child, hazardous materials, and the woman who has mobility issues were well received by the participants. They were able to identify with these particular instances. This connection can be attributed to the phased table-top methodology used in developing the table-top exercise.

The hazard analysis was consulted upon and 12 of the 16 *very likely* and *nearly to occur* hazards were addressed. The hazards analysis was found in the Richmond County Emergency Plan (2013). FEMA uses a similar methodology in identifying the tasks and capabilities required for emergency situations (United States, Department of Homeland Security, 2006). In the FEMA framework, 15 scenarios were developed in their National Planning Scenarios, and from the scenarios tasks were identified for the Universal Tasks List and then the Target Capabilities were constructed from the Tasks List (FEMA, 2007b). The systematic approach proved to be valuable in creating the structured table-top exercise for which the participants were able to identify. The connection between the hazards and detailed events allowed for gaps to be identified and categorized following the table-top exercise.

5.3.1.2 Community and EOC Members Involvement

The second point of interest in delivering the table-top exercise is the inclusion of the community members. Through the C-Change Project, community members and partners were informed of the table-top exercise and were invited to participate in the discussion alongside members of the Richmond County EOC. The benefit of having community members involved is twofold.

The inclusion of community members insures an element of transparency in the emergency operation and responders are held accountable. Gaps identified by members of the public can be brought to elected officials and best practices can be developed through pressure from those who participated. The second benefit is found in the proactive attitude of

community members. These threats may hit closer to home for the community than they do for members of the emergency response team. For example, in the case of Little Anse, many of the responders live in Isle Madame but not directly in Little Anse. Those who live in Little Anse are more aware of the vulnerabilities in their neighbourhood. For this reason, it is observed that community members are more proactive and engaged in discussion during the table-top exercise and in their willingness to participate in follow-up, addressing shortcomings and identified gaps. This attitude ensures better implementation of best practices.

Challenges were seen in engaging all members of the EOC team. Several noticeable absentees for the Case of Little Anse included the Transportation and Infrastructure Renewal Department, the RCMP, Tourism and Economic Development Isle Madame, and the Chief Administrative Officer. The absence of these key individuals and organizations may have had an effect on the performance of the table-top exercise.

5.3.2 Obstacles and Areas of Improvement

Upon completion of the table-top exercise, two areas that can be improved upon were identified: (1) Resources and (2) Response Process. The following section discusses obstacles faced during the table-top exercise and how they can be improved upon.

5.3.2.1 Resources

Participants of the table-top exercise often deployed all resources possible to respond to a localized event. Little Anse and Isle Madame are jurisdictionally a part of Richmond County and therefore have access to all the resources of Richmond County if needed, however it is often the case that storm events are not localized to an individual area of Richmond County. In the event of a storm it is often seen that resources would be spread thin to respond to other communities in the county as well.

The result from this strategy of deployment presents a false sense of preparedness. For example, in the case of the Little Anse table-top exercise participants deployed all 25 volunteer fire fighters to alert the residents of Little Anse going door-to-door. Participants discussed an estimated alert notification time of one hour to inform the entire community. Often the case is

that not all 25 volunteers are present that day, and also Little Anse is not the only community in the County that needs to be alerted.

In many cases the addition of random events or methods of failure will accommodate for the issue of overabundance in resources due to perceived localized events. Resources must be limited during a table-top exercise. This issue is also addressed in Chapter 6 of this study.

5.3.2.2 Response Process

The second obstacle observed during the table-top exercise is the participants' lack of detailed approach to responding to discussion questions. In several cases participants provided the end result but not necessarily the process to achieve that end result.

Two examples were noted from the Little Anse exercise: HAZMAT team and ground search and rescue. In the event of the weld shop collapse, participants decided upon deploying a HAZMAT team, but did not provide the name of the contact person or the process required to bring in the HAZMAT team. Questions that remain to be answered include: (1) What are the capabilities of this HAZMAT team? (2) What needs to be done from the administrative end to bring in the team? (3) How will they be integrated into the current emergency management system? The same could be said about the ground search and rescue operation that was deployed to find the missing girl in the second phase of the table-top exercise. It was generally assumed that someone would contact the appropriate people, but the sources were only tacitly identified.

A lack of detail about the response process will enable gaps to go unnoticed. Community capabilities and expected end results can be identified in most cases, however the process may prove to be challenging in the event of an actual emergency. A strong relationship between all parties involved is shown when names of key contacts and their contact information can be clearly identified during the response process and discussion.

5.3.3 Gaps and Response

The following section itemizes gaps identified during the table-top exercise for the case of Little Anse. Six items were identified and in most cases a solution was discussed immediately.

1. **Social Profile Map.** The creation of a social profile map for the community serves two purposes as identified during the table-top – (1) identification of individuals with special needs and (2) identification of individuals with special skills. Items on the list can be as simple as: Name, Contact Information, Abilities, and Challenges.

During evacuation emergency responders do not have a method to account for everyone in the community nor were they able to identify individuals who may require special assistance. Common special assistance situations seen in Little Anse include: dementia, down syndrome, diabetes, addictions and language barriers.

In cases where responders are not able to properly deploy individuals from the community with special skills can be called upon. These skills can range from medical (first aid and CPR), to linguistics (sign language) and even more technical (operating a front end loader). A social profile and map of the community would enable members of the EOC to determine individuals who have these skills and call upon them.

2. **Roles and Responsibility Alternates.** The designation of alternates for roles and responsibilities during emergency situations must be addressed. The absence of the four key individuals / organization from the table-top exercise is a sign that alternates were not available or identified.

Roles and responsibilities could be better defined through the use of the Incident Command System. In extreme circumstances, external organizations that are not customary to responding to emergencies in Little Anse can be called in. The use of an incident command system and better definition of responsibilities will enable external organizations to integrate into the response operation.

3. **Communication and Awareness Campaigns.** Communication with the public before, during and after a storm is a gap that can be improved upon. It was mentioned during the table-top exercise that Colchester County in Nova Scotia has an occasional “EMO Corner” in their local newspaper to update community members of emergency preparedness events and activities in the community. Participants of the table-top then suggested the preparation of a video clip to raise awareness through Telsle (local television station). An increased presence on Twitter and Facebook was also suggested for the community of Richmond County.

Awareness in terms of resources available for response also needs to be increased. Table-top participants were not aware of the resources the Red Cross and Salvation Army can provide. This calls for a better relationship between aid organizations and the Community of Isle Madame. As mentioned during the exercise, the Red Cross will explore the possibility of repositioning supplies (i.e., flood clean-up kits) to address the needs of the communities on Isle Madame. As part of the Red Cross’s relationship building initiatives with the community it was recommended that Richmond County inaugurate a Red Cross Volunteer Team.

4. **Outreach.** Emergency preparedness should be advocated through outreach programs to schools and community groups. During the visit to Isle Madame by C-Change and Red Cross representatives on May 2nd, 2014, many of those who were talked to were not aware of Emergency Preparedness Week in Canada, May 6-10, 2014. As part of the outreach initiative C-Change was able to deliver Public Safety Canada’s “Your Emergency Preparedness Guide” (Public Safety Canada, 2012) to two local High Schools – Ecole Beau-Port in Arichat, and Richmond Academy in Louisdale. C-Change has also developed a lesson plan for climate adaptation education that can be delivered through the classrooms

(Clarke, 2012). This lesson plan was delivered to the Vice-Principals of both these high schools.

5. **Recovery.** Responsibilities during the recovery phase were not clearly defined as observed during the table-top exercise. The last detailed event raised questions about how water quality testing is carried out following the flooding of Little Anse. There was confusion amongst community and EOC members as to who is responsible for conducting and paying for the testing to be done. The inconsistency may be due to some residents being on the community water system and others on groundwater wells. This is a gap that needs to be addressed and clarified to decrease recovery time as well as reduces the insurance obstacles that may arise following a storm.
6. **Adaptation Strategies.** Long term planning calls for the creation of an alternate route to access the community. If the main road leading into Little Anse floods, an alternate route further inland would prove to be invaluable to the community. During the table-top exercise an abandoned ATV trail leading up to the staging area of the Social Action Centre from Penny's Lane was discussed. It was discussed that the clearing of the trail could be assigned as a summer employment project, e.g., that the Development Isle Madame Association (DIMA) could undertake given funding availability. An alternative method is to designate the trail as a nature trail in hopes of attracting tourists and locals similar to the Eco Trail in Cape Auget. The trail will naturally clear as the frequency of users increase.

This chapter has presented the framework for a phased table-top exercise as well as applied it to the coastal community of Little Anse, Cape Breton, Nova Scotia (May 1st, 2014). A critical analysis following the exercise was conducted and strengths and weaknesses of the framework were identified, areas of improvement were noted. Lastly, the several gaps within Richmond County's Emergency Plan (Municipality of the County of Richmond, 2013) and operation process were identified using the presented framework.

The following chapter presents the final component of emergency preparedness and response, reliability and the ability to manage uncontrollable events during response.

6 Emergency Response Simulation Framework

This chapter presents a framework for a table-top exercise simulation model. The case of the Community of Little Anse in Isle Madame N.S. is used as an example and a simulation model is constructed based on the requirements and hazards as identified in Richmond County's Emergency Plan (2013). The framework presented in this chapter outlines a methodology to evaluate decision making in the Emergency Operations Centre given uncontrollable events that may affect the response operation.

Section 6.1 focuses on structured decision making for Emergency Operations Centre decisions. Section 6.2 presents the use of decision trees for the detailed events previously constructed for the Little Anse table-top exercise. In section 6.3, the *Arena* simulation model is presented along with the analyses for three alternative decision strategies: random, intra-community, and extra-community. An evaluation of the effectiveness of these strategies further illustrates the framework of the model for use by the community to enhance its preparedness state.

6.1 Structured Decision Making with Uncontrollable Events

The need for a simulation model is evident in the fact that the response strategies cannot be tested during or in hindsight of a storm. Emergency management personnel would benefit from a tool that enables response discussions and evaluates decisions that would normally be carried out in the EOC. As defined in Chapter 3, to be successful the community must have plans and resources, be able to make informed decisions, and be prepared to manage uncontrollable events.

A value-based approach is used to evaluate the outcomes following an uncontrollable event. A utility value that ranges from 0 to 1 is estimated for the outcomes based on the alternative selected and the chance event following the decision. The utility represents the quality or effectiveness of the response operation, as demonstrated in the proceeding case study. The control of the state probabilities and utility outcomes enable the exercise designer

to construct the simulation while ensuring it reflects the capabilities of the community to be studied.

Given the alternatives, estimated state probabilities, and outcome utilities, the decision tree can be analyzed and evaluated. Different strategies can be simulated and evaluated using the simulation model. The following section applies decision tree methodology to the case of the breakwater failure in the coastal community of Little Anse.

6.2 Decision Making Under Risk

The framework for constructing a simulated table-top exercise is applied to the case of the breakwater failure in the coastal community of Little Anse. This section documents the process of developing decision trees for the detailed events mentioned in the Little Anse table-top exercise.

6.2.1 Decision Tree Construction

Each detailed event used in the model is constructed using a decision tree. Inspiration for the decision tree design stems from first listing the key narrative scenarios and then the response tasks required.

The following section presents the narrative scenario and response tasks for three sample events (alert community, fallen tree, and trapped car). The three sample events were chosen to demonstrate the different modelling approaches, which are discussed in detail in Section 6.2.2. Table 6-1 summarizes the approaches taken to model all nine detailed events. The full decision tree can be found in Appendix E – Detailed Event Decision Trees.

6.2.1.1 Alert Community

The event of alerting the community forces decision-makers to select a method of warning the public about the pending storm. The narrative and response tasks for this event are summarized below (see also Section 5.2.2.1):

Narrative Scenario

1. Winter storm is causing significant damage

2. Storm tide may soon be too strong for the damaged breakwater

Response Tasks Required

1. Declare a state of emergency if necessary (using proper procedure for this type of storm event)
2. Alert community of the pending danger
3. Alert partner organizations that may be called upon for assistance

The alert/notification decision alternatives can be classified as: (i) direct (e.g., mobile communication application, telephone web, door-to-door), (ii) passive (e.g., television, radio, website, social media), and (iii) passive without the articulation of the action required to be carried out by community members (e.g., sirens).

The tradeoffs are found in the time it takes to activate an early warning. A direct approach will reach more members of the community, however, this notification will require more time. The passive approach requires less time, but may not be as effective in reaching certain subpopulation groups. The outcome is the proportion of the population of the community who has received notification about the pending storm (exposure).

6.2.1.2 Fallen Tree

To respond to a fallen tree several resources must be deployed, as identified in the response tasks required. These resources are RCMP, EHS, and NS Power. Eventually, all three services will be required to respond, however the order in which they can be deployed based on availability is crucial for the outcome of this event. The narrative and response tasks for this event are summarized below (see also Section 5.2.2.2 regarding the table-top exercise):

Narrative Scenario

1. Tree knocked over blocking road
2. Property damage to house, no longer inhabitable
3. One person injured and needs immediate medical attention
4. Live electrical/power lines on the ground

Response Tasks Required

1. Unblock the road (RCMP)
2. Secure damaged house and ensure no one enters the hazardous area (RCMP)
3. Provide transportation, shelter and medical care for those affected (EHS)
4. Contain threat of the live wire (NS Power)

The decision alternatives available for responders to select from are the 3 services and who will coordinate as first on scene. The outcomes, as determined for this exercise, were selected to be the number of casualties: one, two or three.

6.2.1.3 Trapped Car

Narrative for a car trapped in the brackish pond after it has been washed off the road presents responders with two decision alternatives; deploy a tow truck to pull the car out or use a fire truck ladder to reach the trapped man. The narrative and response tasks for this event are summarized below (see also Section 5.2.2.3 regarding the table-top):

Narrative Scenario

1. Strong storm tides have washed a car into the brackish pond
2. Man in his 70s trapped and is at risk of drowning and/or hypothermia
3. Strong currents may wash the car further into the pond if not rescued soon

Response Tasks Required

1. Block off the road
2. Rescue the man and treat him for hypothermia if necessary
3. Remove the car from the pond for environmental reasons

There is an element of time associated with the deployment of these vehicles. The possible outcomes are that: the man is unconscious with hypothermia, he is rescued conscious with hypothermia, or he is rescued safely.

Table 6-1 Summary of the decision tree models for the nine detailed events. A description is provided with the decision alternatives, state probabilities and outcomes

Event Name	Description	Alternatives	State Probabilities	Outcomes
1. Alert Community	Must select a method of warning the community that disseminates to the as many people as possible before the storm arrives.	-Direct -Passive with Articulation -Passive without Articulation	Exponential is applied to the arrival of the storm. Each alternative will take a set time to execute. $\lambda = 1/12$ (Refer to Section 6.2.2.1)	The outcomes represent the percentage of the community alerted. The distribution of the outcomes will depend on the alternative selected.
2. Fallen Tree	Fallen tree has damaged part of a house and claimed one casualty. Live power lines are exposed. Must select primary vehicle for deployment.	-NS Power -RCMP -EHS	Probabilities are estimated based on the scenarios. (Refer to Section 6.2.2.2)	Outcomes are the number of people injured from this event. The outcomes are represented by utility values.
3. Trapped Car	Man has car washed into the barachois pond and is now trapped in the freezing water. Must select a method to rescue the man	-Tow Truck -Fire Truck	The normal distribution is applied to the decision alternative. Tow truck ($\mu = 1, \sigma = 2$) Fire truck ($\mu = 2, \sigma = 1$) (Refer to Section 6.2.2.3)	The outcomes are that the man was: safely rescued (0-1hr), conscious with hypothermia (1-2.5hr) or unconscious with hypothermia (2.5+hr).
4. Lost Child	Young girl lost and responders must organize a search operation	-Volunteer Search -Volunteer and Red Cross -Provincial Search and Rescue Team	The normal distribution is applied to the decision alternative. Volunteers ($\mu = 2, \sigma = 1.5$) Volunteer and Red Cross ($\mu = 3, \sigma = 1$) Provincial Search and Rescue ($\mu = 4, \sigma = 0.5$)	The outcomes are finding the girl safely (0-4hr), finding her unconscious (4-7hr), and not finding her (7+hr). Utility scores were used to evaluate these outcomes.

Event Name	Description	Alternatives	State Probabilities	Outcomes
5. Disabled Woman	Woman with disability requires aide after her power went out. Must decide on the service to deploy.	-Community Oriented -RCMP -EHS	The normal distribution is applied to the decision alternative. Community oriented ($\mu = 0.75, \sigma = 2$) RCMP ($\mu = 1, \sigma = 1.5$) EHS ($\mu = 1, \sigma = 1$)	The outcomes are finding the elderly woman safe with mobility (0-1.5hr), with limited mobility (1.5-3hr) or with no mobility (3+hr). Utility scores were assigned based on the level of care that each alternative can provide.
6. Hazardous Material	Responders must decide on whether to remove hazards from a weld shop before it collapses, contain it from the outside, or to do nothing. There is the risk the shop collapsing and the hazards exploding.	-Go In -Contain from Outside	The exponential distribution was applied to the arrival of the shop collapse and explode event. The mean arrival time was selected as 3. The state probabilities are the probabilities of this exponential falling in the outcome intervals.	The go in alternative has 3 possible outcomes: collapses and explodes before responding (0-1hr), while responding (1-1.5hr), or hazards safely contained (1.5+hr). The contain from outside option has 2 outcomes: collapses and explodes before responding (0-1.25hr), or after perimeter was created (1.25+hr).
7. Evacuate	This event calls for the type of evacuation alert to be issued if required. There is only one road leading into Little Anse that will flood over at any moment and an informed decision on the level of evacuation is required.	-Evacuate Everyone Assisted -Evacuation Advisory with Assistance for Pop. at Risk -Evacuation	Exponential is applied to the time in which the road becomes inaccessible. Each alternative requires time to fully execute. If fully executed - Everyone Assisted (3hr), Population @ Risk Assisted (2hr), Evacuation Advisory (3hr), No Evacuation (3hr).	If the road floods after the decision alternative has been fully executed then the maximum percentage of people evacuated for that alternative is achieved. If the road floods before then a linear decrease in percentage alerted is observed. Similar to the "alert" event.

Event Name	Description	Alternatives	State Probabilities	Outcomes
		Advisory -No Evacuation		
8. Heart Attack	Determine method to reach and attend to heart attack victim before road closes. Road may close on the way in or on the way out.	-Road EHS -Airlift EHS	The exponential ($\lambda = 0.4$) is applied to when the road closes or when wind conditions become too strong. The timeline for a road deployment is: deploy (0-0.5hr), treat (0.5-1.5hr) and safely return (1.5+hr). The timeline for an air deployment is: deploy (0-1hr), treat (1-2hr) and safely return (2+hr). If the storm event occurs in the deploy interval then responders will not be able to reach the victim. If the event occurs in the return interval then responders will not be able to return.	There are four possible outcomes for each alternative. If the responders cannot reach victim then a neighbour can be deployed to assist. The neighbour may be successful or not. If the responders can be deployed then they may need to treat in situ if they are unable to return. The utility values are estimated based on the level of care responders are able to provide.
9. Water Quality	Must decide on whether to let community members back into Little Anse or not.	-Allow Reentry -Do Not Allow Reentry	State probability values were estimated for this event.	There are 4 possible outcomes: do not let community members return, return with no disease outbreaks, 2 outbreaks, or 4 outbreaks. Utility scores were assigned to these outcomes.

6.2.2 Decision Tree Sample Calculation

The following section provides sample calculation for the three types of decision trees used in the simulation model. The first is a tree that applies the exponential distribution to the arrival time of the uncontrollable event (mean time of the storm event arrival). The second is a case where the state probabilities are estimated from experience and based on knowledge of the community's response capabilities. The third example is a decision tree where the normal distribution is applied to the alternative selected (mean time of the response operation).

6.2.2.1 Alert Community (Exponential Distribution Applied to Storm Event)

The state probabilities for this detailed event employ the use of an exponential function to determine the time until the storm will arrive. The lambda value of the exponential function (events in one unit of time) is adjusted to reflect the capabilities of the community. A community with reliable weather forecasting systems may have a longer mean duration before the storm arrives. For the Community of Little Anse, a lambda value of 1/12 storm/hour is chosen, i.e., the expected time before the storm event occurs is 12 hours.

The exponential distribution is a continuous function; however, a decision tree requires the construction of a set of discrete events that will occur in a future state. For this reason, each discrete event of the probability tree is assigned a bin (range of input values from the exponential distribution).

The following is a timeline of the alert community detailed event. Emergency management personnel must select a decision alternative that disseminates to as many community members as possible before the storm arrives. Storm arrival can fall anywhere between 0 hours and infinity, however the mean is 12 hours as determined by the lambda value. There are three possible outcomes for each chance node in this decision tree. The outcome of "short time until storm hits" will occur when the exponential falls within 0 to 6 hours. The outcome of "medium time until storm hits" will occur when the storm arrival time falls between 6 and 12 hours. The final outcome, "long time until storm hits", will occur when the storm arrives in 12 hours or greater.

The state probabilities for these events are calculated from the exponential distribution with $\lambda = 1/12$

Short time until storm hits	$P(X \leq 6)$	= 0.39
Medium time until storm hits	$P(6 < X \leq 12)$	= 0.24
Long time until storm hits	$P(X > 12)$	= 0.37

The percentage of the community who heard the early warning message and willing to respond are calculated under the assumption that the “direct”, “passive with articulation”, and “passive” methods will alert 90%, 80% and 50% respectively if achieved fully, meaning that its full activation time must fall within the bin in which the storm arrives or before the storm arrives. The time required to activate these methods of notification are assumed to be 18, 14 and 10 hours. A simple linear model is used to derive the actual percentage of community members responding. For example, if the direct method requires 18 hours to achieve 90% exposure, then 12 hours will yield 60% exposure, 6 hours will yield 30%, etc.

6.2.2.2 Fallen Tree (Estimated State Probabilities)

The second type of decision tree used in the simulation does not employ the exponential distribution. Therefore, the state probabilities were populated based on prior experience and knowledge of the community’s capabilities. The narrative and hazards involved also play a role in determining the state probabilities.

In the case of the fallen tree event, the response tasks required include: unblocking the road, securing the hazardous area, providing medical aide and containing the live power line. The outcomes will vary depending on which organization is deployed first to mobilize the scene. When Nova Scotia Power is not deployed immediately to contain the live wire, responders face increased threat of being electrocuted. When the EHS is not deployed first, the victim under the fallen tree may succumb to further injuries.

The state probability values were populated by analyzing the narrative and determining how the outcomes would play out depending on resource arrival and availability for the response operation.

The outcomes were assigned a utility value that ranges from zero to one, with one being the most desirable and zero being the least desirable outcomes.

6.2.2.3 Trapped Car (Normal Distribution Applied to Decision Alternative)

In the detailed event of the trapped car that has been washed off the road, the exponential distribution is applied to the duration of the response operation. The lambda value representing the mean response time, will vary depending on the alternative selected.

In the scenario of the trapped car, there are two decision alternatives to select from for deployment – tow truck and fire truck. The task to be completed requires responders to rescue a man trapped in the barachois pond after his car was swept into the water. The man is expected to show signs of hypothermia after 1 hour and become unconscious after 2.5 hours (Minnesota Sea Grant, 2014). These values were estimated based on studies about hypothermia and exposure time.

The response time for deploying a fire truck follows a normal distribution with a mean of 2 hours and standard deviation of 1 hour and the response time for a tow truck deployment has a mean of 1 hour and standard deviation of 2 hours. These values can be adjusted based on the capabilities of the community. Once a decision alternative has been selected, the normal distribution is applied to the model to determine the outcome. The uncontrollable discrete events of each decision alternative are assigned bins. The discrete outcomes are “rescue safely”, “conscious with signs of hypothermia” or “unconscious with hypothermia”. If the response time falls between 0 and 1 hour, the “rescue safely” outcome will occur, between 1 and 2.5 hours then “conscious with signs of hypothermia” will occur, and if greater than 2.5 hours then “unconscious with hypothermia”.

The following shows the calculation of the state probabilities for the outcome events when the tow truck is selected ($\mu = 1, \sigma = 2$)

Rescue Safely	$P(X \leq 1)$	= 0.5
Conscious with hypothermia	$P(1 < X \leq 2.5)$	= 0.27
Unconscious with hypothermia	$P(X > 2.5)$	= 0.23

The outcomes are measured using a utility value. The least desired outcome would be “unconscious with hypothermia” and was therefore assigned a utility value of zero. Rescuing conscious with hypothermia was assigned a value of 0.7, and finally, a safe rescue received a value of one.

6.3 *Arena* Simulation Model Analysis

A process simulation model is built following the concepts presented with the decision trees. The following section presents an overview of the model (Section 6.3.1) as well as an analysis of the decision making strategies evaluated (Section 6.3.2).

6.3.1 Model Overview

This section provides an overview of the framework for creating the *Arena* simulation model based on the events presented in the Little Anse table-top exercise. This model is constructed based on estimated values for the overall community of Isle Madame, Nova Scotia.

6.3.1.1 Timeline

The *Arena* simulation environment is constructed with two processes representing two timelines – (i) the storm event timeline, and (ii) the rescue response timeline. The storm event timeline is used to model the arrival of uncontrollable events (e.g., storm arrival and time until road floods over). The response timeline is used to model the response time for the different decision alternatives. The *Arena* simulation environment model screenshots are provided in Appendix F – *Arena* Simulation Model.

6.3.1.2 Performance Measures

The measures of performance used for evaluation of the decision strategies are dependent on the events. The first event (Alert Community) has an outcome that represents

the percentage of community members who have been alerted (“exposure”) of the pending storm event. Events two through six have outcomes of utility scores. The outcome of the seventh event (Evacuate) corresponds to the percentage of community members safely evacuated. The final two events, have outcome values of utility scores. In this framework, these utility scores can be adjusted based on community values.

6.3.1.3 Controllable Variables

The controllable variables of this simulation model are the decision alternatives. The decision alternatives are input through an assignment module in *Arena*. Each event has two to four decision alternatives.

6.3.1.4 Uncontrollable Factors

The uncontrollable factors built into this model are found in two modules: the arrival of storm related events (e.g., storm arrival, road floods, and tree collapse) and the execution of the decision alternative selected (i.e., response time). In most cases, both the response time and the storm related event are floated based on a probability distribution function. The parameters for these functions are estimated based on knowledge of the community of study.

6.3.2 Strategy Alternatives

Four different decision strategies are evaluated using the simulation model.

- (a) Expected Values. The decision based on expected values is a strategy derived from the analysis of the decision trees presented in Section 6.2.
- (b) Random. For the “random decision making” strategy, decision alternatives are selected at random in the *Arena* simulation model.
- (c) The intra-community and (d) extra-community strategies follow a decision path where response is considered as either bottom-up or top-down, respectively. A bottom-up response operation uses community resources and is community member-based. A top-down approach, on the other hand, uses resources brought in and generally is coordinated by a higher level of government or aid organization than that of the local community.

The results containing the outcomes percentages and utility values for these alternative strategy applications and performances measures are presented in Table 6-2. A detailed summary of the results from the simulation is provided in Appendix G – *Arena* Simulation Model Output Summary.

Table 6-2 indicates that the best performance strategies are given by either the expected value results of Appendix E, or the randomized decision strategies. Further, it is evident from Table 6-2, that the top-down or bottom-up strategies underperform relative to the other strategies.

Table 6-2 Summary of mean outcome values for the four response decision strategies tested. The highest value for each event is shown in bold.

Event	1	2	3	4	5	6	7	8	9
Exp.Value	59.27%	0.8250	0.6914	0.9633	0.9172	0.6632	64.45%	0.7162	0.8000
Random	38.89%	0.900	0.710	0.860	0.780	0.680	37.73%	0.760	0.880
Intra	42.05%	0.750	0.380	0.640	0.580	0.500	23.57%	0.520	0.520
Extra	36.76%	0.775	0.520	0.500	0.650	0.500	34.89%	0.520	0.800

6.3.2.1 Best Decisions from Expected Value Decision Trees

The decision path that provides that highest expected value of either utility score or percentage of community members alerted is calculated using the decision trees discussed in Section 6.2. The full decision trees can be found in Appendix E – Detailed Event Decision Trees. The suggested decision alternative and expected value of utility / percentage is provided in Figure 6-1.

The expected values for percentages and utility are greater than that observed from the intra-community and extra-community. This is expected because a weighted average of the outcome values is calculated and the decision alternative that provides the greatest outcome was selected and proposed for this strategy.

It should be noted that the outcomes for the expected value approach is not greater than the outcomes for random decision making for the events of: trapped car, fallen tree, hazardous materials, heart attack victim, and public health. This observation may be attributed

to the number of repetitions. Ten repetitions were performed for the random decision making strategy.

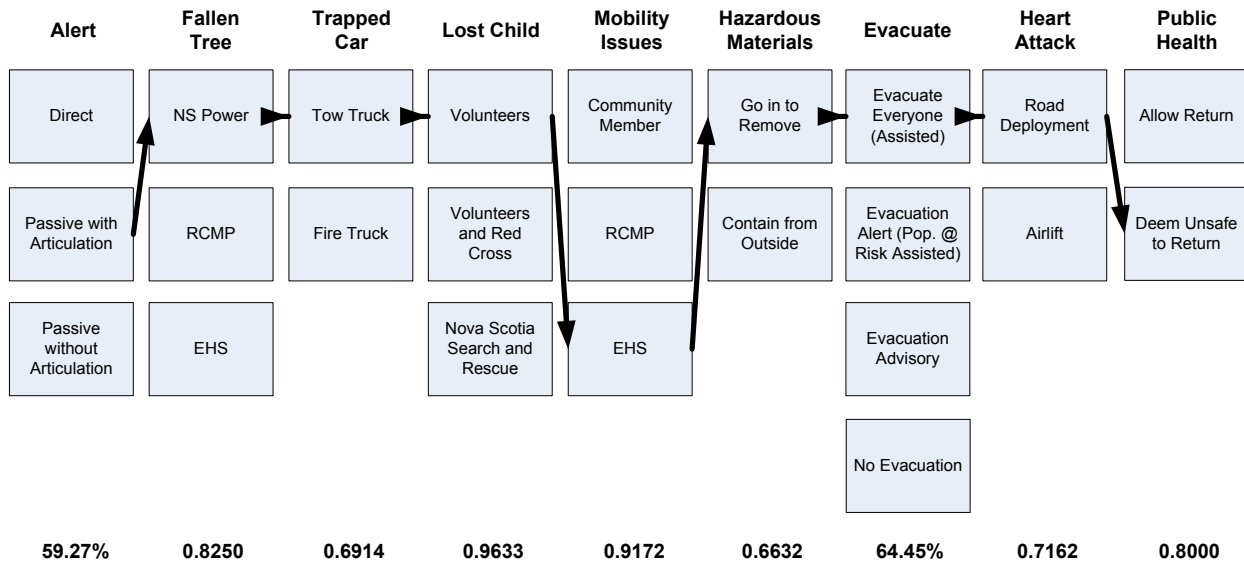

Figure 6-1 Decision path based on the expected value approach calculated from the decision trees. The path suggested would yield the highest expected value for the utility score or percentage (shown at the bottom) for each event.

6.3.2.2 Random Decision Making

Under random decision making, the *Arena* simulation environment selected from the different alternatives based on a uniform distribution. Every alternative has an equally likely chance of being selected. The count for each alternative following ten simulation runs is shown in the first table of Appendix G – *Arena* Simulation Model Output Summary. A summary of the results for this strategy is shown in Figure 6-2.

Alert	Fallen Tree	Trapped Car	Lost Child	Mobility Issues	Hazardous Materials	Evacuate	Heart Attack	Public Health
38.89%	0.900	0.710	0.860	0.780	0.680	37.73%	0.760	0.880

Figure 6-2 Mean utility and percentage values for each event based on a random decision making strategy

The results for this strategy are generally greater than that of the intra-community and extra community approaches, with the expectation being the first event, alert community. It is interesting to see that emergency management applied from one end of the spectrum (bottom-up) or the other (top-down) would not yield an optimal outcome. In this case, the mean of the

outcomes following a series of random path repetitions proved to be better than an intra-community or extra-community response.

6.3.2.3 Intra-Community (Bottom-Up Approach)

The intra-community approach to decision making during an emergency calls for responders to rely on community owned and operated resources and well as an active participation from community members. The decision path chosen for this strategy generally employs the use of volunteers, small scale operations, or community based resources and values. In cases where all of the decision alternatives do not clearly represent an intra-community decision, an estimation based on what Little Anse would carry out is selected. The decision path selected for this alternative is shown in Figure 6-3.

The results are lower than the expected value and random decision approaches. The outcomes are also lower than the extra-community approach for five of the events.

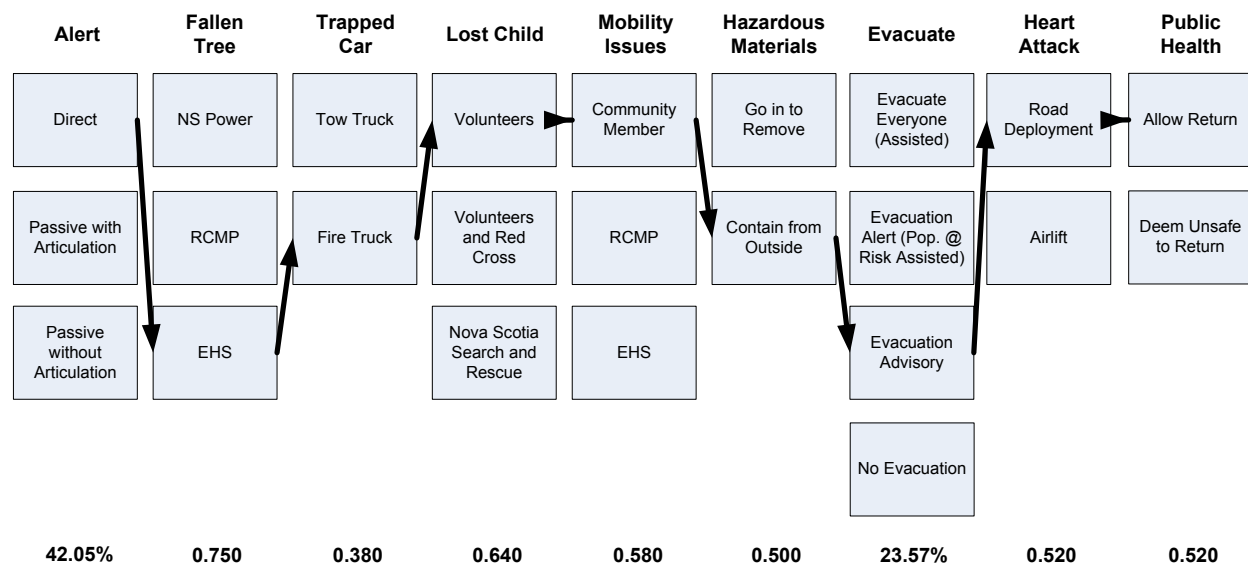

Figure 6-3 Decision path based on an intra-community decision making strategy. The mean utility and percentage for each event following the simulation is shown at the bottom of the figure.

6.3.2.4 Extra-Community (Top-Down Approach)

The extra-community approach is a top-down response strategy. Decisions rely on resources from other communities or higher levels of government. The decision path is shown in Figure 6-4. The mean outcomes following the simulation of this strategy is lower than the

expected value and random decision approaches. However, for most events, this approach has outcomes that are greater than or equal to the intra-community approach.

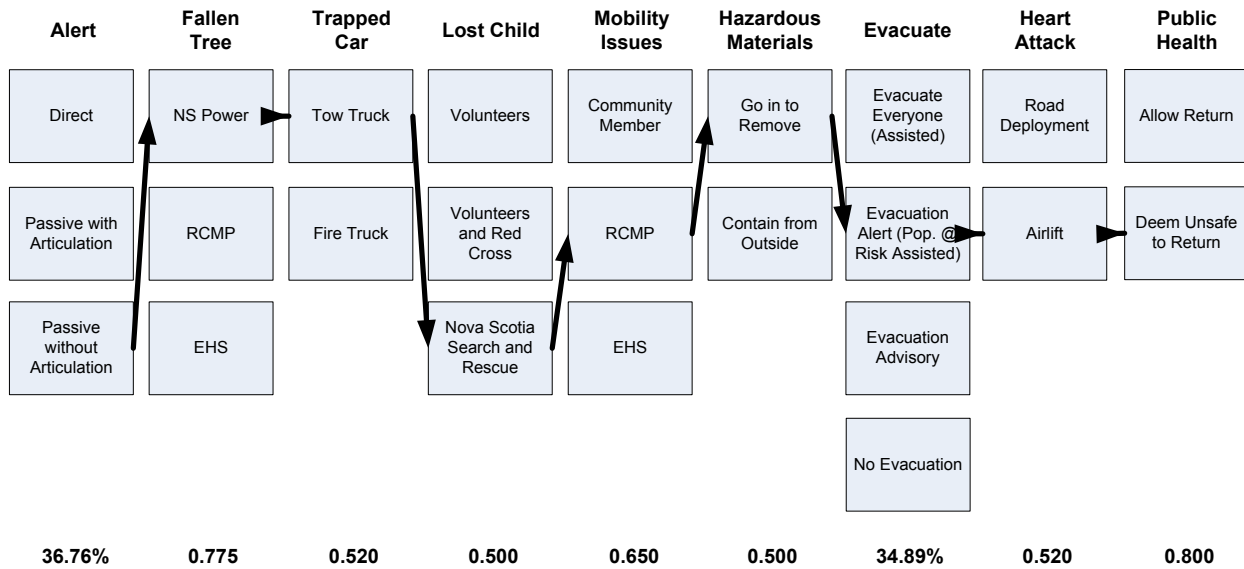

Figure 6-4 Decision path based on an extra-community decision making strategy. The mean utility and percentage for each event following the simulation is shown at the bottom of the figure

This chapter presented the framework for constructing a simulation model to evaluate decision strategies during emergency situations. The simulation model incorporates the probabilities for uncontrollable events. Given informed decision making, an uncontrollable event, like storm arrival time, can still alter the outcome.

The framework proposed the use of a simulation tree for each detailed event. The case of the breakwater failure in the community of Little Anse was used and the events designed in this model mirror the events of the table-top exercise. The model parameters (e.g., response time) were estimated for Richmond County, the County responsible for responding to emergencies in Little Anse.

The decision trees were conducted using an inductive approach where a narrative scenario was examined and specific response tasks were identified. Based on the response tasks a suite of decision alternatives were created for the event. The decision trees were analysed using an expected value approach.

The following chapter provides a conclusion to this thesis and offer recommendations for future studies.

7 Conclusions and Recommendations

This thesis has provided a comprehensive approach to defining preparedness and response in coastal communities with respect to the effects of severe storms, sea level rise, and storm surges. The following chapter provides a conclusion for the research and discusses how the research questions have been addressed (Section 7.1). Recommendations for future studies to build on the work completed in this thesis are presented in Section 7.2. Section 7.3 provides a brief discussion about the future of climate change adaptation and disaster risk reduction.

7.1 Conclusion

This thesis has demonstrated a framework to define, measure and simulate coastal community preparedness and response for severe environmental events (e.g., storm surges, floods, and hurricanes). The components of preparedness and response were identified using literature. To be prepared and able to successfully conduct a response operation, communities must have the necessary resources, well-conceived emergency plans, informed decision making, and the ability to manage uncontrollable events.

The first research question proposed for this thesis was, “What does it mean for communities to be prepared for emergency situations?” Community preparedness was examined from multiple scopes and objectives to identify what it means to be prepared (Chapter 4). The objectives range from an all-hazards approach (e.g., Public Safety Canada’s Federal Emergency Response Plan), hazards explicitly shown (e.g., FEMA’s National Planning Scenarios), and natural hazards (e.g., United nation’s Hyogo Framework for Action). The scope of these approaches range from the international level down to the local level. This literature review enabled the development of the components of preparedness and response (resources, emergency plans, decision making, and reliability), as shown in Figure 7-1.

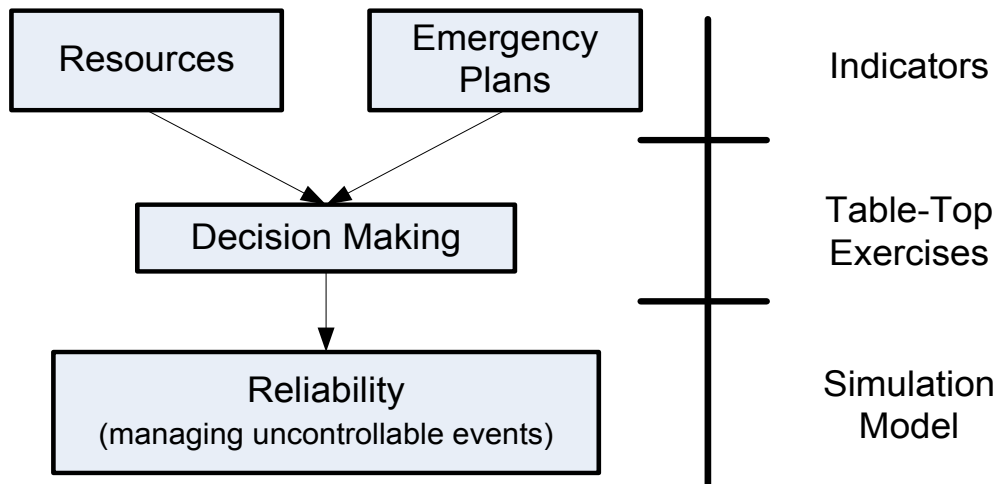

Figure 7-1 The components of emergency preparedness and response, and what this study has done to address each component

The second research question asked, “How can this concept of preparedness be applied to coastal communities vulnerable to sea level rise and more frequent severe storms?” As identified in Figure 7-1, preparedness requires sufficient resources and a well-designed emergency plan. Key elements from the literature approaches were used to construct a classification table of preparedness. Thirty-one indicators were developed from the classification table (Chapter 4). The methodology employed in creating the indicators ensured that the values of coastal communities can be represented in the framework. A survey was sent out to the eight C-Change partner communities to gather scoring information for the indicators.

The question of effectiveness and reliability for the existing emergency response system was raised in the third research question. A phased table-top exercise methodology was proposed to capture the effectiveness of the existing response system (Chapter 5). The phased table-top exercise was then applied to the case of the breakwater failure in Little Anse, Isle Madame, Nova Scotia. Members of the Richmond County Emergency Operations Centre were asked to navigate through nine structured events, drawn up to address the hazards identified in the community hazard analysis.

Reliability refers to the response system’s ability to withstand uncontrollable events and outcomes. Given resources, response plans, and informed decision making, there is still a

chance that an undesirable outcome will occur. A simulation model was therefore created in the *Arena* simulation environment that enables responders to input empirical data and evaluate decision strategies (Chapter 6). Empirical data for the response (e.g., response time and early warning activation time) is needed to assess a community's response reliability. This thesis used estimated values for the community of Richmond County to demonstrate the framework for the simulation.

Following the table-top exercise and *Arena* simulation model, areas of the response operation that require improvement were identified. Identifying these areas and developing best practices addresses the fourth research question, "What actions are required to improve preparedness and response?" Six gaps were identified following the table-top exercise. In many cases participants at the table-top were proactive in developing ways to address these gaps. The gaps and responses of participants are discussed in Section 5.3.3.

7.2 Recommendations for Further Study

Any document in the field of emergency management is a living document. The same can be said about this thesis. Obstacles were encountered during this study and further research must be conducted to build upon this study. The following section presents the challenges of this study and provides recommendations for further study of the three major contributions of this thesis.

7.2.1 Indicators of Preparedness

Following the construction of indicators, an online questionnaire was sent to the community champion of the eight C-Change partner communities to collect indicator scores. To date, only the community of Isle Madame, Nova Scotia has completed the questionnaire. This may be a gap in terms of awareness of emergency preparedness in these communities. Information may not be widely accessible and community members may simply not be aware of their community's capabilities.

Future work can be conducted in collecting this information and using the hierarchy framework to conduct a gap analysis on the communities. The gap analysis should reveal areas to be improved upon and show where the community stands in terms of preparedness relative to the ideal state. With the mentioned data, a sensitivity analysis could be performed to determine how certain indicators will affect the overall performance of the system. This information may be critical in budget allocation and investments towards increasing community preparedness.

7.2.2 Table-Top Exercises

The strengths and weaknesses of the phased table-top exercise were discussed in Section 5.3. However, following the exercise, an area of concern is how this framework will be implemented in the community. Simulation exercises should be an ongoing process where best practices can be improved upon. Applications from this study have set the foundation for table-top exercises to be conducted in the community of Isle Madame. However, it is now the community's responsibility to carry on with these exercises.

A follow-up report (after-action report) will be produced for the May 1st, 2014 exercise in Isle Madame, Nova Scotia. The follow-up report will present the gaps identified and recommendations for the community. The report will act as a resource document for the community.

Further research into a methodology to evaluate table-top exercises quantitatively and set a bench mark for improvement is fundamental to the framework presented in this study. A quantitative benchmark encourages emergency management personnel as well as community members to improve upon current protocols.

This study focused on the use of table-top exercises, however, several exercise types exist (e.g., workshops, games, drills, full-scale). Research into the methods of applying the framework presented in this thesis to other exercise types would be beneficial to communities as well.

7.2.3 Storm Response Simulation

The storm response simulation utilized estimated data as parameters for the model. The strategies examined (random decisions, intra-community, and extra-community) were used to demonstrate the framework. However, empirical data from the communities would make this study more applicable. The next phase of the model development would be to acquire empirical data and experiment with a community.

The information required for this simulation model is not widespread in smaller communities and this may be a gap in how information is collected during storm events. Another obstacle in the attempt to acquire this information lies in the false sense of resource abundance. This issue was mentioned in Section 5.3.2.1; emergency management personnel often assume that the operation is flawless. An example of this is when participants of the table-top were asked to estimate the time it takes to alert community members by going door-to-door. Responders automatically assumed all 25 volunteer firefighters are available for deployment. This is not often the case in reality.

Therefore, future studies must focus on acquiring empirical data with respect to the response of smaller communities to build on the framework presented in this thesis.

Several observations were made about the state of climate change adaptation and disaster risk reduction in coastal communities during this study. The following section examines the current state of climate change adaptation and disaster risk reduction as well as presents an approach to create a more sustainable system for both these fields.

7.3 Future Research in Climate Change Adaptation and Disaster Risk Reduction

There is a profound link between climate change adaptation and disaster risk reduction, as seen in this study. However, it is often seen that these two areas of study continue to progress independently of each other. Climate change adaptation and disaster risk reduction can mutually benefit through an integration of knowledge because they share similar objectives.

As seen in the literature review, there continues to be a split in approaches to managing disasters. Disaster risk reduction approaches often neglect the social and cultural dimensions. There is knowledge to be gained through studying the community's social and cultural profile and the dynamics of a community based bottom-up approach. While climate change adaptation approaches can benefit from the more developed disaster management knowledge of disaster risk reduction (Venton & La Trobe, 2008).

This study shows the importance of collaboration and communication from practitioners and policy makers in both fields. The gap in the spectrum of emergency preparedness and response (from CCA to DRR) has hindered the process in which resources and knowledge can be fully optimized. Communities will continue to face these challenges until a comprehensive risk management approach can be developed through the integration of these fields.

"If climate change adaptation policies and measures are to be efficient and effective they must build on and expand existing disaster risk reduction efforts. And if Disaster risk reduction approaches are to be sustainable they must account for the impact of climate change." (Venton & La Trobe, 2008)

This research and the C-Change Project have brought light to the gap between disaster risk reduction and climate adaptation. The table-top exercise was presented as a collaboration between C-Change, the Canadian Red Cross and the Community of Isle Madame Nova Scotia. Knowledge from disaster risk reduction was integrated with community-based approaches of climate adaptation to provide a comprehensive definition of emergency preparedness and response.

Bibliography

Adger, W. N. (1999). Social vulnerability to climate change and extremes in coastal Vietnam.

World Development, 27(2), 249-269.

Alberta Emergency Management Agency. (2012). Alberta Emergency Resources Inventory System. Retrieved October 17, 2013, from http://www.aema.alberta.ca/pa_aeris.cfm

Bain, V., Gaume, E., & Bressy, A. (2010). *Methods and case studies in post flood event data collection and analysis*. Project Deliverable No. 4.1. HYDRATE Project Consortium.

Retrieved from

http://www.hydrate.tesaf.unipd.it/WareHouse/ProjectDeliverables/DELIVERABLE_HYDRATE_WP4.pdf

BC Stats. (2013). Population Estimates. Retrieved March 2, 2013, from

<http://www.bcstats.gov.bc.ca/StatisticsBySubject/Demography/PopulationEstimates.aspx>

Beñas, M. B. (2011). Philippines: Automated weather stations to help mitigate disasters

(Philippines Information Agency Press Release). Retrieved October 17, 2013, from

<http://preventionweb.net/go/20848>

Canada Office of the Auditor General. (2009). Chapter 7, emergency management - Public Safety Canada. *Report to the House of Commons*. Ottawa, ON: Minister of Public Works and Government Services Canada. Retrieved from

http://publications.gc.ca/collections/collection_2009/bvg-oag/FA1-2009-3-7E.pdf

Canada Senate. (2008). *Emergency preparedness in Canada*. Standing Senate Committee on National Security and Defence, Second Session, 39th Parliament.

Caribbean Community Secretariat. (2010). Finland pledges to support CARICOM's sustainable development efforts. Retrieved May 18, 2014, from

http://www.caricom.org/jsp/pressreleases/pres247_10.jsp

Carleton University CUSERT. (2013). About us - CUSERT. Retrieved September 25, 2013, from

<http://cusert.carleton.ca/about-us/>

- C-Change. (2011a). Charlottetown, Prince Edward Island. Retrieved April 4, 2013, from <http://www.coastalchange.ca/index.php/communities/canada-community-profiles/charlottetown-prince-edward-island>
- C-Change. (2011b). Isle Madame, Nova Scotia. Retrieved April 4, 2013, from <http://www.coastalchange.ca/index.php/communities/canada-community-profiles/isle-madame-ns>
- C-Change. (2011c). Project overview. Retrieved February 3, 2013, from <http://www.coastalchange.ca/index.php/the-project/description>
- City of Melbourne. (2009). *Melbourne Community Safety Audit Program*. Application Form. Retrieved from <http://www.melbourne.vic.gov.au/CommunityServices/CommunitySafety/Documents/CommunitySafetyAuditPilotProgram.pdf>
- City of New Orleans. (2013). Community outreach. Retrieved October 17, 2013, from <http://www.nola.gov/homeland-security/community-outreach/>
- City of Ottawa. Office of the Auditor General. (2006). Chapter 6, audit of the emergency management program. *Audit Report*. Retrieved from <http://app06.ottawa.ca/cs/groups/content/@webottawa/documents/pdf/mdaw/mdq3/~e disp/wc015271.pdf>
- City of Red Deer. (2011). Emergency management committee. Retrieved October 18, 2013, from <http://www.reddeer.ca/City+Government/City+Services+and+Departments/Legislative+and+Administrative+Services/Council+Committees/Emergency+Management+Committee/default.htm>
- City of Victoria. (2014). Emergency management. Retrieved March 21, 2014, from <http://www.victoria.ca/EN/main/departments/emergency-management.html>
- Clarke, A. J. (2012). *Canada-Caribbean Communities' Schools Curricula Project: Developing C-Change Lesson Plans*. C-Change Working Paper No. 39. Ottawa: C-Change Secretariat Canada.

- Cutter, S. L., Barnes, L., Berry, M., Burton, C., Evans, E., Tate, E., & Webb, J. (2008). A place-based model for understanding community resilience to natural disasters. *Global Environmental Change, 18*(4), 598-606.
- David, A. B., & Theriault, M. (2013). *Municipality of the County of Richmond: Municipal climate change action plan*. The Municipality of the County of Richmond. Retrieved from <http://www.richmondcounty.ca/images/News%20&%20Events/MCCAP%202013%20final%20report.pdf>
- DeVellis, R. F. (1991). *Scale development: theory and applications*. California: SAGE Publications.
- Drabek, T. E. (2005). Predicting disaster response effectiveness. *International Journal of Mass Emergencies and Disasters, 23*(1), 49-72.
- Duke, A. (2012). Fans want Bloomberg's Sandy signer back. *CNN*. Retrieved from <http://www.cnn.com/2012/11/01/us/sandy-bloomberg-interpretor/index.html>
- Emergency Communications Ontario Association. (2013). CANWARN. Retrieved October 17, 2013, from <http://www.ecoa.ca/canwarn.shtml>
- Emergency Management British Columbia. (2012a). *The all-hazard plan*. Province of British Columbia. Retrieved from http://www.embc.gov.bc.ca/em/hazard_plans/All-Hazard_Plan.pdf
- Emergency Management British Columbia. (2012b). *The British Columbia flood response plan*. Province of British Columbia. Retrieved from http://www.embc.gov.bc.ca/em/hazard_plans/BC-Flood_Response_Plan_2012.pdf
- Emergency Management Ontario. (2009). *Guidelines for the development of an exercise program*. Retrieved March 16, 2013, from http://www.emergencymanagementontario.ca/english/emcommunity/program_resources/exercise/exercise_guidelines_main.html
- Emergency Management Ontario. (2010). *Participant manual for the Basic Emergency Management Course*. Toronto.

Environment Canada. (2004). The top ten Canadian weather stories for 2004. Retrieved March 16, 2013, from <http://www.ec.gc.ca/meteo-weather/default.asp?lang=En&n=9CA2BD37-1#archived>

Environment Canada. (2012). Canadian tropical cyclone season summaries. Retrieved March 31, 2013, from <http://www.ec.gc.ca/ouragans-hurricanes/default.asp?lang=en&n=23B1454D-1>

Environment Canada. Canadian Meteorological Centre. (n.d.). GEM the global environmental multiscale model: Introduction. Retrieved March 31, 2013, from http://collaboration.cmc.ec.gc.ca/science/rpn/gef_html_public/INTRODUCTION/gem_intro.html

Environmental Tectonics Corporation. (2013). ADMS simulation training systems. Retrieved September 6, 2013, from <http://www.trainingfordisastermanagement.com/>

ESRI. (n.d.). Emergency/disaster management. Retrieved May 18, 2014, from <http://www.esri.com/industries/public-safety/emergency-disaster-management>

Etkin, D., Medalye, J., & Higuchi, K. (2012). Climate warming and natural disaster management: An exploration of the issues. *Climatic Change*, 112(3-4), 585-599.

Expert Choice Inc. (2004). Expert Choice 11 (11th ed.). Arlington, Virginia.

FEMA. (2007a). *National preparedness guidelines*. Retrieved March 2, 2013, from http://www.fema.gov/pdf/emergency/nrf/National_Preparedness_Guidelines.pdf

FEMA. (2007b). Target capabilities list: A companion to the national preparedness guidelines. Retrieved January 15, 2013, from <http://www.fema.gov/pdf/government/training/tcl.pdf>

FEMA. (2012). *FEMA incident action planning guide*. Department of Homeland Security. Retrieved from [http://www.uscg.mil/hq/cg5/cg534/nsarc/FEMA%20Incident%20Action%20Planning%20Guide%20\(IAP\).pdf](http://www.uscg.mil/hq/cg5/cg534/nsarc/FEMA%20Incident%20Action%20Planning%20Guide%20(IAP).pdf)

FEMA. (2013). Emergency planning exercises. Retrieved March 1, 2013, from <http://www.fema.gov/emergency-planning-exercises>

- Flannery, T. F. (2007). *The weather makers: how we are changing the climate and what it means for life on earth*. Toronto, ON: HarperCollins.
- Gillespie, D. F., & Streeter, C. L. (1987). Conceptualizing and measuring disaster preparedness. *International Journal of Mass Emergencies and Disasters*, 5(2), 155-176.
- Glahn, B., Taylor, A., Kurkowski, N., & Shaffer, W. A. (2009). The role of the SLOSH model in National Weather Service storm surge forecasting. *National Weather Digest*, 33(1).
- Government of British Columbia. (2013). *Emergency program act*. Retrieved March 18, 2013, from www.bclaws.ca/EPLibraries/bclaws_new/document/ID/freeside/00_96111_01
- Government of Canada. (2013). *Emergency management act*. Retrieved March 18, 2013, from www.laws-lois.justice.gc.ca/PDF/E-4.56.pdf
- Government of Nova Scotia. (2013). Nova Scotia community counts. Retrieved March 12, 2013, from www.gov.ns.ca/finance/communitycounts/profiles/community/default.asp?gnew=&table=&acctype=0&chartid=&mapid=&dcol=&sub=&ptype=geo&tid=&gview=7&glevel=wsp&gnum=wsp46&gnum2=wsp46&yearid=2011
- Government of Nunavut. (2010). Nunavut emergency management. Retrieved March 2, 2013, from www.cgs.gov.nu.ca/en/commEmergency.aspx
- GPC Public Affairs. (2005). *Are Canadians prepared for an emergency? An analysis of Canadians' preparedness for emergency situations and attitudes toward preparing for them: Final report to Public Safety and Emergency Preparedness Canada*. Retrieved September 6, 2013, from www.epe.lac-bac.gc.ca/100/200/301/pwgsc-tpsgc/por-ef/public_safety_emergency/2005/2005-1468/2005-1468-e.pdf
- Grasso, V. F. (2009). *Early warning systems: State-of-art analysis and future Directions (UNEP draft report)*. Retrieved October 16, 2013, from http://na.unep.net/geas/docs/early_warning_system_report.pdf
- Hartt, M. (2011). *Geographic information systems and system dynamics: Modelling the impacts of storm damage on coastal communities*. M.Sc. Systems Science, University of Ottawa. Telfer School of Management.

- Hauser, C. (2005). Sustained by close ties, Vietnamese toil to rebuild. *The New York Times*.
- Hevner, A. R., March, S. T., Park, J., & Ram, S. (2004). Design science in information systems research. *MIS Quarterly*, 28(1), 75-105.
- Hong Kong Observatory. (2014). Rainstorm warning system. Retrieved May 18, 2014, from <http://www.hko.gov.hk/wservice/warning/rainstor.htm>
- IEMG. (2013). *International emergency management assistance compact operations manual*. Retrieved March 8, 2013, from www.iemg-gigu-web.org/PDF/GOM-e.pdf
- IFRC. (2008). *The Red Cross Red Crescent and the Hyogo Framework for Action: Focus on the Asia-Pacific region*. Retrieved February 5, 2013, from www.ifrc.org/Global/Case%20studies/Disasters/cs-hyogo-framework-asia-pacific-en.pdf
- IPCC. (2007). *Climate Change 2007: Synthesis Report. Contribution of Working Groups I, II and III to the Fourth Assessment Report of the Intergovernmental Panel on Climate Change*. Geneva, Switzerland: IPCC.
- IPCC. (2012). *Managing the Risks of Extreme Events and Disasters to Advance Climate Change Adaptation. A Special Report of Working Groups I and II of the Intergovernmental Panel on Climate Change*. Cambridge, UK: Cambridge University Press.
- IPCC. (2013). *Climate Change 2013: The Physical Science Basis. Contribution of Working Group I to the Fifth Assessment Report of the Intergovernmental Panel on Climate Change*. Cambridge, UK: Cambridge University Press.
- Jacks, E., Davidson, J. & Wai, H. G. (2010). *Guidelines on early warning systems and application of nowcasting and warning operations*. World Meteorological Organization Publication. Retrieved October 16, 2013, from <http://www.wmo.int/pages/prog/amp/pwsp/documents/PWS-21.pdf>
- Jackson, B. A. (2008). *The problem of measuring emergency preparedness: The need for assessing "response reliability" as part of homeland security planning*. Santa Monica, California: RAND Corporation.

- Jackson, B. A., Sullivan Faith, K., & Willis, H. H. (2011). Are we prepared? Using reliability analysis to evaluate emergency response systems. *Journal of Contingencies and Crisis Management, 19*(3), 147-157.
- Kapucu, N. (2008). Collaborative emergency management: Better community organising, better public preparedness and response. *Disasters, 32*(2), 239-262.
- Kelton, W. D., Sadowski, R. P., & Sturrock, D. T. (2007). *Simulation with Arena* (4th ed.). Boston: McGraw-Hill Higher Education.
- Kirschenbaum, A. (2002). Disaster preparedness: A conceptual and empirical reevaluation. *International Journal of Mass Emergencies and Disasters, 20*(1), 5-28.
- Klein, R. J. T., Nicholls, R. J., & Thomalla, F. (2003). Resilience to natural hazards: How useful is this concept? *Environmental Hazards, 5*(1-2), 35-45.
- Koh, H. K., & Cadigan, R. O. (2008). Disaster preparedness and social capital. In I. Kawachi, S. V. Subramanian & D. Kim (Eds.), *Social Capital and Health* (pp. 273-285). New York: Springer.
- Lewis, J., & Miller, K. (2010). *Climate change adaptation plan for Iqaluit*. Retrieved April 4, 2013, from http://www.planningforclimatechange.ca/wwwroot/Docs/Library/CommAdptPlans/IQALUIT_REPORT_E.PDF
- Mathbor, G. M. (2007). Enhancement of community preparedness for natural disasters: The role of social work in building social capital for sustainable disaster relief management. *International Social Work, 50*(3), 357-369.
- McConnell, A., & Drennan, L. (2006). Mission impossible? Planning and preparing for crisis. *Journal of Contingencies and Crisis Management, 14*(2), 59-70.
- McElroy, A. (2013). Sirens sound yet deaf people left standing. Retrieved August 29, 2013, from <http://www.unisdr.org/archive/34528>
- MEOPAR. (2013). Marine environmental observation prediction and response network. Retrieved March 15, 2013, from <http://meopar.ca>
- Minnesota Sea Grant. (2014). Hypothermia prevention: Survival in cold water. Retrieved May 16, 2014, from http://www.seagrant.umn.edu/coastal_communities/hypothermia

- Mostofi Camare, H. (2011). *Multicriteria decision evaluation of adaptation strategies for vulnerable coastal communities*. M.Sc. Systems Science, University of Ottawa. Telfer School of Management.
- Municipality of Anchorage. (n.d.). Emergency management - Contact us. Retrieved October 17, 2013, from <http://www.muni.org/Departments/OEM/Pages/ContactUs.aspx>
- Municipality of Phuket. (2008). *Disaster management plan Patong Municipality of Phuket*. Retrieved October 17, 2013, from http://www.unep.fr/shared/publications/pdf/ANNEXES/4.3%20Disaster%20Management%20plans/Disaster%20management%20plan_Patong.pdf
- Municipality of the County of Richmond. (2013). *Municipality of the County of Richmond Emergency Response Plan*. Retrieved July 22, 2014, from <http://www.richmondcounty.ca/images/EMO/RICH%20CO%20E%20PLAN%202013.pdf>
- Nakagawa, Y., & Shaw, R. (2004). Social capital: A missing link to disaster recovery. *International Journal of Mass Emergencies and Disasters*, 22(1), 5-34.
- National Weather Service. (2013). What is SKYWARN? SKYWARN recognition day: Dec. 7, 2013. Retrieved May 18, 2014, from <http://www.nws.noaa.gov/skywarn/>
- Nebraska Urban Search and Rescue Task Force One. (2005). *Hurricane Katrina After- Action Report*. After-Action report. Nebraska:
- Nelson, D. R., Adger, W. N., & Brown, K. (2007). Adaptation to environmental change: contributions of a resilience framework. *Annual Review of Environment and Resources*, 32, 395-419.
- NOAA. (2003). *SLOSH display training*. Retrieved December 18, 2012, from <http://slosh.nws.noaa.gov/sloshPub/SLOSH-Display-Training.pdf>
- NOAA. (2004). *StormReady / TsunamiReady - organization and operations manual*. Retrieved January 28, 2013, from <http://www.stormready.noaa.gov/resources/OpsManual2005.pdf>
- NOAA. (2010). Dickinson County, IA, StormReady status credited with minimizing disaster. Retrieved March 15, 2013, from <http://www.stormready.noaa.gov/success-iowa.htm>

- NOAA. (2012a). Historical SLOSH simulations. Retrieved October 17, 2013, from http://www.nhc.noaa.gov/surge/HistoricalRuns/?large&parm=1900_galveston
- NOAA. (2012b). Sea level rise and coastal flooding impacts. Retrieved April 5, 2013, from <http://www.csc.noaa.gov/slr/viewer/#>
- NOAA. (2013). National Weather Service StormReady. Retrieved January 15, 2013, from <http://www.stormready.noaa.gov/>
- Nova Scotia EMO. (2003). *A report on the emergency response to Hurricane Juan*. Retrieved March 11, 2013, from http://emo.gov.ns.ca/sites/all/themes/emo/files/report_on_the_emergency_response_to_hurricane_juan.pdf
- Nova Scotia EMO. (2004). *Public feedback on the emergency response to Hurricane Juan*. Retrieved March 11, 2013, from http://emo.gov.ns.ca/sites/all/themes/emo/files/public_feedback_on_the_emergency_response_to_hurricane_juan.pdf
- Nova Scotia EMO. (2012). *The Nova Scotia emergency response plan*. Retrieved March 11, 2013, from http://emo.gov.ns.ca/sites/default/files/pdfs/the_ns_emergency_response_plan_may_2012.pdf
- Nova Scotia Weather Service. (2014). Nova Scotia Weather Service Page. Facebook. Retrieved May 18, 2014, from <https://www.facebook.com/novascotiawx>
- O'Brien, K., Sygna, L., Leichenko, R., Adger, W. N., Barnett, J., Mitchell, T., ... Mortreux, C. (2008). *Disaster risk reduction, climate change adaptation and human security*. Report prepared for the Royal Norwegian Ministry of Foreign Affairs by the Global Environmental Change and Human Security Project No. 3.
- O'Leary, M. (2004). *Measuring disaster preparedness: A practical guide to indicator development and application*. Lincoln, NE: iUniverse Inc.
- Paton, D., & Johnston, D. M. (2006). *Disaster resilience: an integrated approach*. Springfield, IL.: Charles C Thomas.

- PEI Office of Public Safety. (2012). Municipal emergency measures plan template. Retrieved March 2, 2013, from <http://www.gov.pe.ca/photos/original/OPS-Munic-Plan.pdf>
- PEI Office of Public Safety. (2013). Municipal emergency management guide. Retrieved March 2, 2013, from http://www.gov.pe.ca/photos/original/EMO_MUN_EMG.pdf
- Pelling, M., & Uitto, J. I. (2001). Small island developing states: Natural disaster vulnerability and global change. *Environmental Hazards*, 3(2), 49-62.
- Perry, R. W., & Lindell, M. K. (2003). Preparedness for emergency response: Guidelines for the emergency planning process. *Disasters*, 27(4), 336-350.
- Petak, W. J. (1985). Emergency management: A challenge for public administration. *Public Administration Review*, 45(Special Issue: Emergency Management: A Challenge for Public Administration), 3-7.
- Philippine Daily Inquirer. (2010). Asian parliamentarians agree to push for 1% of budget for DRR. Retrieved October 18, 2013, from <http://preventionweb.net/go/16844>
- Philippine Information Agency. (2010). Philippines: 'Including DRR in national budget. A step in right direction. Retrieved October 17, 2013, from <http://preventionweb.net/go/16971>
- Port Hawkesbury Reporter. (2014). Breakwater failure the subject of exercise. Retrieved May 7, 2014, from <http://www.porthawkesburyreporter.com/2014/05/07/breakwater-failure-the-subject-of-exercise/>
- Prevention Web. (2012). Korean aid for weather forecasting in Sri Lanka. Retrieved May 18, 2014, from <http://preventionweb.net/go/26065>
- Public Health Agency of Canada. (2006). Annex L: Federal emergency preparedness and response system. Ottawa: Government of Canada.
- Public Safety Canada. (2011a). *An emergency management framework for Canada*. Retrieved September 8, 2013, from <http://www.publicsafety.gc.ca/cnt/rsrscs/pblctns/mrgnc-mngmnt-frmwrk/mrgnc-mngmnt-frmwrk-eng.pdf>
- Public Safety Canada. (2011b). *Federal emergency response plan*. Retrieved March 31, 2013, from <http://www.publicsafety.gc.ca/cnt/rsrscs/pblctns/mrgnc-rspns-pln/index-eng.aspx>

- Public Safety Canada. (2011c). *National emergency response system*. Retrieved September 8, 2013, from <http://www.publicsafety.gc.ca/cnt/rsrscs/pblctns/ntnl-rspns-sstm/ntnl-rspns-sstm-eng.pdf>
- Public Safety Canada. (2012). *Your emergency preparedness guide: 72 hours. Is your family prepared?* Retrieved May 15, 2014, from <http://www.getprepared.gc.ca/cnt/rsrscs/pblctns/yprprdnssgd/index-eng.aspx>
- Public Safety Canada. (2013). *Emergency management*. Retrieved December 20, 2013, from <http://www.publicsafety.gc.ca/cnt/mrgnc-mngmnt/index-eng.aspx>
- Raiffa, H. (1968). *Decision analysis: Introductory lectures on choices under uncertainty*. Reading, Massachusetts: Addison-Wesley Publishing Company Inc.
- Reece, J. B., Urry, L. A., Cain, M. L., Wasserman, S. A., Minorsky, P. V., Jackson, R. B., & Campbell, N. A. (2011). *Campbell biology* (Ninth ed.).
- Richardson, G. R. (2010). *Adapting to climate change: An introduction for Canadian municipalities*. Ottawa, ON: Natural Resources Canada.
- Rockwell Automation. (2012). *Arena* (14th ed.)
- Rogers, D., & Tsirkunov, V. (2010). *Global assessment report on disaster risk reduction: Costs and benefits of early warning systems*. Retrieved October 26, 2013, from http://www.preventionweb.net/english/hyogo/gar/2011/en/bgdocs/Rogers_&_Tsirkunov_2011.pdf
- Saaty, T. L. (1990). How to make a decision: The analytic hierarchy process. *European Journal of Operational Research*, 48(1), 9-26.
- Schneider, S. K. (2011). The gap between bureaucratic norms and emergent norms. *Dealing with Disaster: Public Management in Crisis Situations* (pp. 60-80). New York: M.E. Sharpe Inc.
- Shaftel, D. (2006). The ninth re-ward: The Vietnamese community in New Orleans East rebuilds after Katrina. *The Village Voice*.

- Simpson, D. M., & Katirai, M. (2006). *Indicator issues and proposed framework for a disaster preparedness index (DPi)*. Unpublished manuscript. Retrieved September 8, 2013, from <http://www.fritzinstitute.org/PDFs/WhitePaper/DaveSimpson%20IndicatorsRepor.pdf>
- Simpson, D. M. (2008). Disaster preparedness measures: A test case development and application. *Disaster Prevention and Management*, 17(5), 645-661.
- Smit, B., & Wandel, J. (2006). Adaptation, adaptive capacity and vulnerability. *Global Environmental Change*, 16(3), 282-292.
- Statistics Canada. (2010). Police resources in Canada. Retrieved May 18, 2014, from <http://www.statcan.gc.ca/pub/85-225-x/85-225-x2010000-eng.pdf>
- Stevenson, W. (2010). *Introduction to management science* (1st Canadian ed.). New York: McGraw-Hill.
- Tashakkori, A., & Teddlie, C. (1998). *Mixed methodology: Combining qualitative and quantitative approaches*. (Applied Social Research Methods Series Volume 46 ed.). California: Sage Publications Inc.
- Tenser, P. (2013). FEMA funding allows Colorado to establish counselling for flood victims in 9 counties. *ABC 7 News: The Denver Channel*. Retrieved from <http://www.thedenverchannel.com/lifestyle/health/fema-funding-allows-colorado-to-establish-counseling-for-flood-victims-in-9-counties>
- UN/ISDR. (2005). Hyogo Framework for Action 2005-2015: Building the resilience of nations and communities to disasters. Extract from the final report of the World Conference on Disaster Reduction. Retrieved from <http://www.unisdr.org/2005/wcdr/intergover/official-doc/L-docs/Hyogo-framework-for-action-english.pdf>
- UN/ISDR. (2007). *Stop disasters - A disaster simulation game from the UN/ISDR* Retrieved from <http://www.stopdisastersgame.org/en/home.html>
- UN/ISDR. (2012). Bangladesh highlights shortage of cyclone shelters as UNISDR chief visits. Retrieved October 17, 2013, from <http://www.unisdr.org/archive/26009>
- UN/ISDR & UN/OCHA. (2008). *Disaster Preparedness for Effective Response Guidance and Indicator Package for Implementing Priority Five of the Hyogo Framework*. Geneva,

Switzerland: United Nations secretariat of the International Strategy for Disaster Reduction (UN/ISDR) and the United Nations Office for Coordination of Humanitarian Affairs (UN/OCHA).

United States, Department of Homeland Security. (2005). Universal task list version 2.1.

Retrieved September 6, 2013, from

<http://www.ncrhomelandsecurity.org/ncr/downloads/Universal%20Task%20List.pdf>

United States, Department of Homeland Security. (2006). National planning scenarios version

21.3. Retrieved May 17, 2014, from <http://publicintelligence.net/national-planning-scenarios-version-21-3-2006-final-draft/>

University of Chicago. (2014). Emergency response plan for floods. Retrieved May 17, 2014,

from <http://safety.uchicago.edu/pp/emergency/floods.shtml>

University of Ottawa. (2013a). Fact book - enrolment by program. Retrieved May 17, 2014,

from <http://www.uottawa.ca/services/irp/eng/fact-figures/fact/students.html>

University of Ottawa. (2013b). Rely on uOttawa alert. Retrieved October 7, 2013, from

<http://www.emergencypreparedness.uottawa.ca/tools.html>

Vaishnavi, V., & Kuechler, B. (2013). Design science research in information systems. Retrieved

July 9, 2014, from <http://desrist.org/desrist/content/design-science-research-in-information-systems.pdf>

Venton, P., & La Trobe, S. (2008). *Linking climate change adaptation and disaster risk reduction*.

Teddington, UK: Tearfund.

Weiss, D. J., & Weidman, J. (2013). Disastrous spending: Federal disaster-relief expenditures

rise amid more extreme weather. Retrieved October 7, 2013,

from <http://www.americanprogress.org/issues/green/report/2013/04/29/61633/disastrou-s-spending-federal-disaster-relief-expenditures-rise-amid-more-extreme-weather/>

World Bank. (2008). As climate change makes weather more unpredictable, improving

forecasting is vital to crops, disaster Mitigation. Retrieved May 18, 2014, from

<http://go.worldbank.org/WBWDR9HD10>

Glossary of Terms

Action Plan – A logical sequence of steps or activities developed for a strategy to succeed

Adaptation – The capacity for human and natural systems to adjust to global and local environmental change by reducing vulnerability and increasing resilience to potential adverse impacts (C-Change, 2011c)

Capability – The power or ability to provide the means to accomplish a mission and achieve desired outcomes by performing critical tasks and achieving desired levels of performance (FEMA, 2007b)

Disaster – A disruption to the community functionality causing widespread human, economic, and/or environmental losses which exceeds the affected population's capability to cope (UN/ISDR, 2005)

Indicators – A quantitative or qualitative identifier to monitor the state of a process

Preparedness – A combination of capacity and knowledge developed by governments, professionals, community groups and individuals to effectively anticipate and respond to hazardous events or conditions (UN/ISDR, 2005)

Resilience – The capacity of a community to be able to absorb stress or destructive forces through resistance or adaptation. Can also be viewed as the ability to manage or maintain functionality during disastrous events and to recover after the event (UN/ISDR, 2005)

Sea Level Rise – An increase in the mean water level of the ocean (Richardson, 2010)

Storm Surge – Refers to the temporary increase in height of the sea level at a specific location due to extreme meteorological conditions (Richardson, 2010)

Vulnerability – The state of susceptibility to impacts of disastrous events from exposure to stresses associated with environmental and social change and from the absence of capacity to adapt (UN/ISDR, 2005)

Appendix A Indicator Score Analysis

This appendix contains a summary table of the indicator score analysis. The scores are derived from a value-based measurement method and then scaled to values between zero and one using a utility function. The following table shows the maximum and minimum value for each indicator using the value-based scoring approach, a description of the indicator, the functional form of utility used in ExpertChoice, the scale type of the value-based measurement and sketch of the utility function. Other information includes an example value before the application of the utility function; sources for said value are shown in the far right column. This appendix adds to the thesis by summarizing all 31 indicators and lays out the scoring methods used.

* Estimated value due to an unreliable source or an indicator that requires multiple dimensions of measurements and therefore values were taken from multiple sources.

+ Maximum values shown with a plus sign indicate that this value is a perfect score but communities may exceed this value.

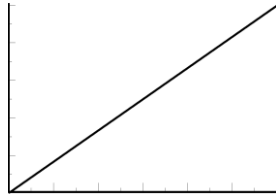
Dimension	Attribute	Indicator	Min	Max	Description	Functional Form/Scale	Utility Function	Example	Source
Communication and Collaboration	Early Warning and Public Information	Early Warning Systems	0	20	Measures the presence absence of early warning system types as well as how information is articulated	Increasing linear / checklist		Hong Kong, CN 12	(Hong Kong Observatory, 2014)

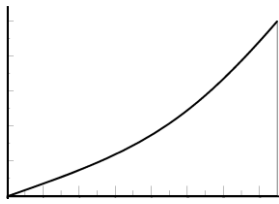
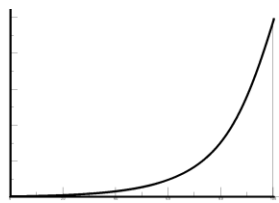
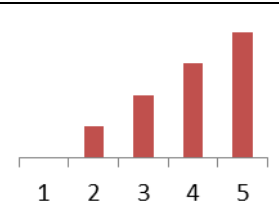
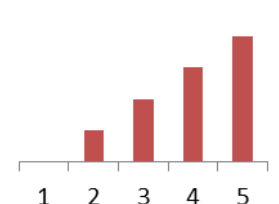
Dimension	Attribute	Indicator	Min	Max	Description	Functional Form/Scale	Utility Function	Example	Source
		Public Information Management	0	15	Measures how frequently information is disseminated	Increasing convex / fuzzy		Victoria, CA 9*	(City of Victoria, 2014)
		Populations at Risk	0	10	Measures whether early warnings and public information can reach five common subpopulation groups	Increasing convex / checklist		New York City, US 10	(Duke, 2012)
	Community Collaborative Networking	Volunteer Participation	1	5	Measures the percentage of community members who volunteer	Ratings / proportion			
		Social, Cultural and faith based Groups	1	5	Measure the percentage of community members who are involved in social or cultural groups	Ratings / proportion			

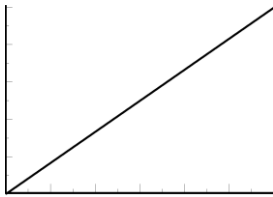
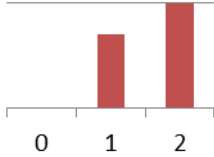
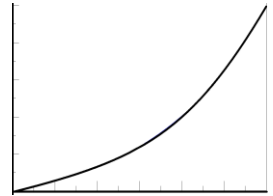
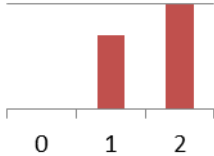
Dimension	Attribute	Indicator	Min	Max	Description	Functional Form/Scale	Utility Function	Example	Source
Monitoring and Forecasting	Data Collection and Management	Data Collection	0	9	Measures how often data are collected for weather, response and damage	Increasing linear / fuzzy		South Tyne, UK*	(Bain et al., 2010)
		After-action Review Process	0	2	Measures the extent of analysis and implementation for collected data	Ratings / checklist		Lincoln, US 2	(Nebraska Urban Search and Rescue Task Force One, 2005)
	Environmental Forecasting	Weather Forecasting Means	0	12	Measures how recent weather monitoring instruments have been updated	Increasing convex / fuzzy		Bangued, PH 6*	(Beñas, 2011)
		Trained Weather Spotters	0	2	Indicator for having community weather spotters who can assist in forecasting	Ratings / checklist		Ontario, CA 2	(Emergency Communications Ontario Association, 2013)

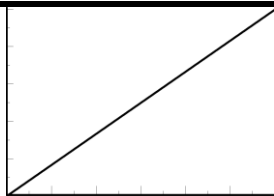
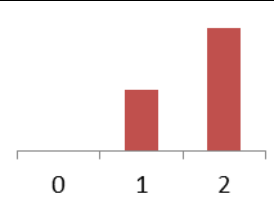
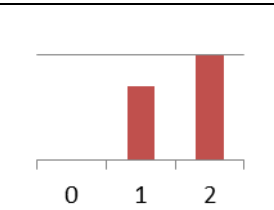
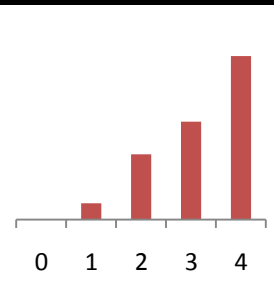
Dimension	Attribute	Indicator	Min	Max	Description	Functional Form/Scale	Utility Function	Example	Source
	Hazard and Vulnerability Analysis	Infrastructure Safety Audit	0	18	Measures when a safety audit was last conducted.	Increasing linear / fuzzy		Melbourne, AU 18*	(City of Melbourne, 2009)
		Public Consultations	0	2	Indicator for a public consultation where community members can report hazardous events	Ratings / presence-absence		Anchorage, US 1*	(Municipality of Anchorage, n.d.)
		GIS Flood Mapping and Simulation Analysis	0	2	Measures whether flood and hazard mapping has been conducted in the area and also when it was last done	Ratings / checklist		Galveston, US 2	(Glahn et al., 2009)
Training, Education and Community Awareness	Capacity Building and Planning	Simulation Exercises	0	4	Measures whether simulation exercises are conducted and if so when the last one was done	Ratings / checklist		Cayman Islands 2 (table-top) Chennai, IN 1* (full scale)	(Port Hawkesbury Reporter, 2014)

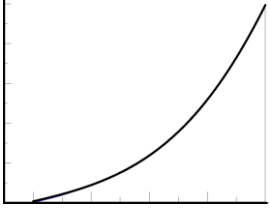
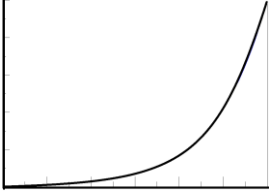
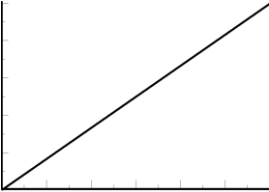

Dimension	Attribute	Indicator	Min	Max	Description	Functional Form/Scale	Utility Function	Example	Source
		Developing an Emergency Response Plan	0	4	Indicator for how well emergency plans coordinate key players and address the hazards and vulnerabilities of the community	Ratings / fuzzy			
	Public Awareness	Household Preparedness	5	25	Evaluates the preparedness measures in place at the household level. These include percentage of households with an emergency preparedness kit, generators, sewer backflow valves, etc.	Increasing convex / proportions			
		Public Outreach	0	12	Measures how recent outreach presentations are delivered.	Increasing linear / fuzzy		New Orleans, US 12*	(City of New Orleans, 2013)

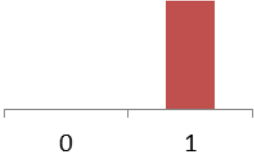
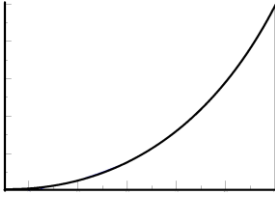
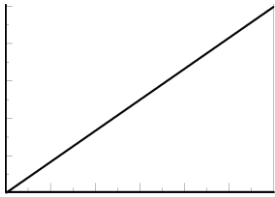
Dimension	Attribute	Indicator	Min	Max	Description	Functional Form/Scale	Utility Function	Example	Source
Emergency Services and Operations	Incident Command System	Incident Command System	0	1	Indicator to determine whether the community has devised an incident command system for emergency situations	Ratings / presence-absence		Phuket, TH 1	(Municipality of Phuket, 2008)
	Emergency Operations	Emergency Operations Centre	0	2	Measures whether an emergency operations centre has been established and tested or not	Ratings / checklist			
	Emergency Operations	Planning for Infrastructure Maintenance	0	1	Indicator for whether infrastructure maintenance has been incorporated into the response operation	Ratings / presence-absence			

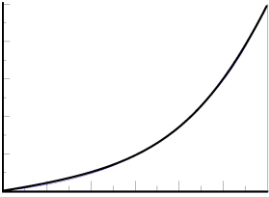
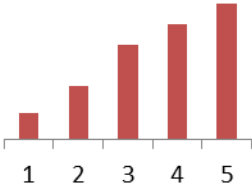
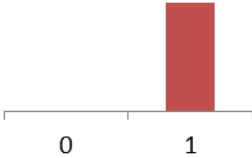
Dimension	Attribute	Indicator	Min	Max	Description	Functional Form/Scale	Utility Function	Example	Source
	Resources	Inventory System	0	1	Indicator for whether a community has an update inventoried of their supplies and equipment that can be deployed	Ratings / presence-absence		Alberta, CA 1	(Alberta Emergency Management Agency, 2012)
		Equipment and Resource Maintenance	0	4	Indicator that measures how often equipment is maintained	Increasing convex / fuzzy			
		First Responders	0	9+	Measures the number of first responders (professional and volunteer) trained and available in the event of an emergency	Increasing linear / proportion			

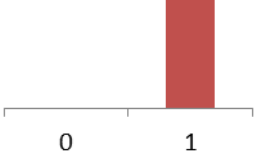
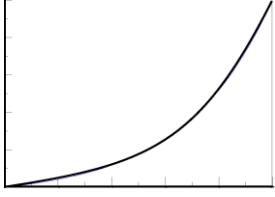
Dimension	Attribute	Indicator	Min	Max	Description	Functional Form/Scale	Utility Function	Example	Source
		Shelters and Evacuation	0	200+	Measures the quantity of shelter and evacuation resources such as sheltering facility and transportation methods	Increasing convex / fuzzy			
Local Governance and Social Services	Preparedness Funds	Disaster Risk Reduction Budget	1	5	Indicator to determine how much of a community's budget overall is allocated for climate change adaptation and disaster risk reduction	Ratings/ interval		Philippines 5	(Philippine Information Agency, 2010)
		Donation Management	0	1	Presence / absence indicator to determine whether plans are in place for donation management	Ratings / presence-absence		Winnipeg, CA 1	(Nova Scotia EMO, 2012)

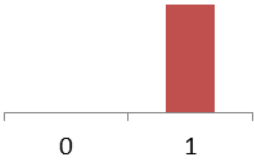
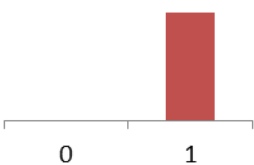
Dimension	Attribute	Indicator	Min	Max	Description	Functional Form/Scale	Utility Function	Example	Source
	Jurisdictions	Joint Meetings	0	2	Measures the number of times meetings are conducted between members of all government levels to discuss emergency management in the past 3 years	Ratings / interval			
		Audit of Activities	0	1	Indicator for whether activities related to emergency preparedness are reviewed and approved upon	Ratings / presence-absence		Ottawa, CA 1	(City of Ottawa. Office of the Auditor General, 2006)
		Judged Orientation	0	1	Measures whether responsibilities for emergency response are bottom up or top down in a community. A value of 0.5 denotes equal responsibilities	Increasing convex / fuzzy			

Dimension	Attribute	Indicator	Min	Max	Description	Functional Form/Scale	Utility Function	Example	Source
		Committees of the Whole	0	1	Indicator to determine whether emergency management committee has been established	Ratings / presence-absence		Red Deer, CA 1	(City of Red Deer, 2011)
	Humanitarian and Mutual Aid	Crisis Counselling	0	1	Indicator to determine whether social services are available to the public in the time of a disaster.	Ratings / presence-absence		Colorado, US 1	(Tenser, 2013)
		Mutual Aid Program	0	1	Indicator to determine whether compacts have been made about mutual aid between jurisdictions in the event of an emergency	Ratings		New Brunswick, CA 1	(IEMG, 2013)

Appendix B Community Preparedness Questionnaire Form

This appendix contains the questionnaire sent out to the eight C-Change partner communities using an online questionnaire tool, www.questionform.com.



Community Preparedness

This document is designed to provide indicators of community preparedness. It will enable better assessment of your community's status and requirements for emergency preparedness in the event of storm surges.

There are 31 items grouped into categories related to emergency preparedness. It should take approximately 20 minutes to complete these items. If you need to consult with Community Partners, please complete the questionnaire to the best of your knowledge and a link will be provided at the the end for you to return later and modify your answers.

Please select your C-Change community. *

Communication and Collaboration

1. Which of the following early warning systems does the community have and do they articulate on the pending threat and action required? *

Please check the present box only if the mentioned system is present in the community. A blank box will denote that the mentioned early warning system is not available. Also, please check the boxes if the system provides an articulation of the threat involved and the action required to respond to the emergency.

	Present	Articulation of threat	Articulation of action
Radio message	<input type="checkbox"/>	<input type="checkbox"/>	<input type="checkbox"/>
Television message	<input type="checkbox"/>	<input type="checkbox"/>	<input type="checkbox"/>
Cell phone message	<input type="checkbox"/>	<input type="checkbox"/>	<input type="checkbox"/>
Door-to-door notification	<input type="checkbox"/>	<input type="checkbox"/>	<input type="checkbox"/>
Other	<input type="checkbox"/>	<input type="checkbox"/>	<input type="checkbox"/>

If 'other' was selected as 'present', please list the other early warning systems used in the community.

2. Which of the following public information methods does the community use and how frequent are announcements broadcasted during a storm? *

Please select the frequency at which public information is disseminated in the community in the event of a storm.

	Ongoing	Hourly	Daily	Not available
Radio	<input type="radio"/>	<input type="radio"/>	<input type="radio"/>	<input type="radio"/>
Television	<input type="radio"/>	<input type="radio"/>	<input type="radio"/>	<input type="radio"/>
Cell phone messaging	<input type="radio"/>	<input type="radio"/>	<input type="radio"/>	<input type="radio"/>
Website updates	<input type="radio"/>	<input type="radio"/>	<input type="radio"/>	<input type="radio"/>
Other	<input type="radio"/>	<input type="radio"/>	<input type="radio"/>	<input type="radio"/>

If 'other' was selected, please list the other public information methods used in the community.

3. Do the early warning and public information systems reach the following subpopulations? *

Please check the boxes only if the system accounts for the listed subpopulations.

	Early Warning Systems	Public Information Systems
School Age 5-18	<input type="checkbox"/>	<input type="checkbox"/>
Young Adult 19-29	<input type="checkbox"/>	<input type="checkbox"/>
Adult 30-65	<input type="checkbox"/>	<input type="checkbox"/>
Senior 65+	<input type="checkbox"/>	<input type="checkbox"/>
Disadvantaged/Disabled	<input type="checkbox"/>	<input type="checkbox"/>

4. What percentage of the community is actively involved in a volunteer opportunity? *

Please select the interval that best describes the proportion of the community that participates in a volunteer opportunity.

- 0%-20%
- 21%-40%
- 41%-60%
- 61%-80%
- 81%-100%

5. What percentage of the community is actively involved in a social, cultural or faith-based group? *

Please select the interval that best describes the proportion of the community that is involved in a social, cultural or faith-based group.

- 0%-20%
- 21%-40%
- 41%-60%
- 61%-80%
- 81%-100%

Monitoring and Forecasting

6. How are data collect during a storm event in the community? *

Data collection promotes financial and end-user accountability throughout the response process and in order to be prepared for future events, collection methods must be established and tested.

Please select how data are collected in the community for the following types of information: weather (wind speeds and direction, temperature, precipitation, etc), response operation (response time, resources deployed, cost, etc) and damage (estimated cost of damage, hazardous areas, etc).

	Continuously	Hourly	Daily	Not available
Weather	<input type="radio"/>	<input type="radio"/>	<input type="radio"/>	<input type="radio"/>
Response Operation	<input type="radio"/>	<input type="radio"/>	<input type="radio"/>	<input type="radio"/>
Damage	<input type="radio"/>	<input type="radio"/>	<input type="radio"/>	<input type="radio"/>

7. Does the community have an after action review process where best practices are developed and implemented? *

Collected data needs to be analyzed post storm and developed into best practices to promote ongoing learning. Please select the after action review process that applies to the community.

- After action review conducted AND best practices implemented
- After action review conducted but best practices NOT implemented
- Not available

8. How recently have weather forecasting equipment been updated in the community? *

Please select the last time the following types of forecasting equipment were updated in the community.

	Within the past year	Within the past 5 years	Within the past 10 years	Not available
Wind equipment (anemometer)	<input type="radio"/>	<input type="radio"/>	<input type="radio"/>	<input type="radio"/>
Water (rain and river) gauges	<input type="radio"/>	<input type="radio"/>	<input type="radio"/>	<input type="radio"/>
Locally owned weather radars	<input type="radio"/>	<input type="radio"/>	<input type="radio"/>	<input type="radio"/>
Other	<input type="radio"/>	<input type="radio"/>	<input type="radio"/>	<input type="radio"/>

If 'other' was selected above, please list the other types of weather forecasting equipment available in the community.

9. Does the community have weather spotters/watchers who can report weather conditions? *

Public weather spotters/watchers are an effective means for gathering micro-forecasting information and for identifying hazards as they develop in the community. Please select the condition that applies to your community.

- Professionally trained weather watchers
- Amateur weather watchers
- Not available

10. How often does the community conduct safety audits on the following infrastructure types? *

Hazardous areas in the community that require extra attention during a storm should be identified beforehand. An infrastructure safety audit is commonly conducted to identify these areas. Please select how often safety audits are conducted on the following infrastructure types.

	<1 year	< 5 years	<10 years	Not available
Buildings	<input type="radio"/>	<input type="radio"/>	<input type="radio"/>	<input type="radio"/>
Roads and Bridges	<input type="radio"/>	<input type="radio"/>	<input type="radio"/>	<input type="radio"/>
Waterfront Infrastructure (docks, quays, wharfs, etc.)	<input type="radio"/>	<input type="radio"/>	<input type="radio"/>	<input type="radio"/>
Water Management	<input type="radio"/>	<input type="radio"/>	<input type="radio"/>	<input type="radio"/>
Utility Lines	<input type="radio"/>	<input type="radio"/>	<input type="radio"/>	<input type="radio"/>
Other Community Assets	<input type="radio"/>	<input type="radio"/>	<input type="radio"/>	<input type="radio"/>

11. Does the community's government organize public consultations for community members to discuss potentially hazardous areas? *

Public consultations offer community members an opportunity to voice their concerns about hazardous areas in the community. Please select the case that applies to the community.

	Present	Absent
Public Safety Consultation Meetings	<input type="radio"/>	<input type="radio"/>
Public Safety Phone Line	<input type="radio"/>	<input type="radio"/>

12. Has a flood map or simulation been conducted for the community using GIS data? *

Please select the scenario that best applies to the community.

- Present and was conducted within the last 5 years
- Present but was not conducted within the last 5 years
- Not available

Training, Education and Community Awareness

13. Has the community conducted simulation table top and full scale exercises for the effects of storm surges? *

Please select the scenario that best represents the work done in the community for table top exercises and full scale exercises.

	Present and has been done in the last 12 months	Present but has NOT been done in the last 12 months	Not available
Simulation Table Top Exercises	<input type="radio"/>	<input type="radio"/>	<input type="radio"/>
Simulation Full Scale Exercises	<input type="radio"/>	<input type="radio"/>	<input type="radio"/>

14. Has the community prepared an emergency response plan that includes: *

Please select whether the community's emergency response plan strongly or weakly designates the coordination of key players and addresses hazards and vulnerabilities of the community. If the community does not have an emergency response plan, please select not available for both rows.

	Strongly designated	Weakly designated	Not available
Coordination of key players	<input type="radio"/>	<input type="radio"/>	<input type="radio"/>
Addresses hazards and vulnerabilities	<input type="radio"/>	<input type="radio"/>	<input type="radio"/>

15. What proportion of the community household is prepared? *

Please select the interval that best represents the proportion of households in the community that has the following storm surge emergency preparedness measures.

	0%-20%	21%-40%	41%-60%	61%-80%	81%-100%
Family Emergency Preparedness Kit	<input type="radio"/>	<input type="radio"/>	<input type="radio"/>	<input type="radio"/>	<input type="radio"/>
Flood Protection (e.g. sewer backflow valves, water tight windows and doors, raised electrical and heating system)	<input type="radio"/>	<input type="radio"/>	<input type="radio"/>	<input type="radio"/>	<input type="radio"/>
Emergency Generators	<input type="radio"/>	<input type="radio"/>	<input type="radio"/>	<input type="radio"/>	<input type="radio"/>
Flood Insurance	<input type="radio"/>	<input type="radio"/>	<input type="radio"/>	<input type="radio"/>	<input type="radio"/>
First Aid Training	<input type="radio"/>	<input type="radio"/>	<input type="radio"/>	<input type="radio"/>	<input type="radio"/>

16. How often are emergency preparedness activities presented in the community? *

Please select the frequency of public outreach for emergency preparedness conducted at the following places in your community. These outreach activities include bringing in guest speakers, holding training exercises, educating the public about how to be prepared, etc.

	Weekly	Monthly	Yearly	Not available
Schools	<input type="radio"/>	<input type="radio"/>	<input type="radio"/>	<input type="radio"/>
Faith-based Organizations	<input type="radio"/>	<input type="radio"/>	<input type="radio"/>	<input type="radio"/>
Social and Cultural Groups	<input type="radio"/>	<input type="radio"/>	<input type="radio"/>	<input type="radio"/>
Other	<input type="radio"/>	<input type="radio"/>	<input type="radio"/>	<input type="radio"/>

Emergency Services and Operations

17. Does the community have an incident command system in place? *

The incident command system is an organizational structure that helps coordinate response efforts where multiple organizations are involved. Please select either present or absent for such a system in the community.

- Present
- Absent

18. Does the community have an emergency operations center? *

Please select the option that best describes the emergency operations center in your community.

- Established and tested
- Established
- Not available

19. Does the community plan for infrastructure maintenance in the event of a storm? *

Infrastructure maintenance refers to clearing roads, fixing utility lines, water and waste management and many other vital tasks during a storm. Does the community have plans for and the capabilities to carry out such tasks?

- Yes
- No

20. Does the community have an up to date inventory database for supplies and resources that can be deployed in the event of a storm? *

- Yes
- No

21. How often are equipment and resources for emergency response maintained? *

- Weekly
- Monthly
- Yearly
- Longer
- Not available (no maintenance)

22. How many first responders are available in the community? *

Please provide the number of professional first responders and the number of volunteer trained first responders serving your community.

Professional first responders	<input type="text"/>
Volunteer first responders	<input type="text"/>

23. How many shelters and evacuation vehicles are available in the community? *

Please enter the number of evacuation shelters that can be opened and operated in the event of a storm. Please enter the number of evacuation vehicles that the government has access to if evacuation is required.

Number of evacuation shelters	<input type="text"/>
Number of evacuation vehicles	<input type="text"/>

Local Governance and Social Services

24. What percentage of the community's budget is allocated for climate change adaptation and disaster risk reduction? *

Budget allocation for climate change adaptation and disaster risk reduction refers to the budget set aside to conduct activities that would not normally be conducted if climate change and natural disasters were not an issue. For example, a budget for first responders would not count because other forms of emergencies would require first responders. Please select the interval for which the percentage of the overall community operating budget that is allocated for climate change adaptation and disaster risk reduction falls.

- 0.00%-0.49%
- 0.50%-0.99%
- 1.00%-1.49%
- 1.50%-1.99%
- 2.00+%

Please list some of the activities that this budget supports.

25. Does the community have a plan to manage donations during a disaster? *

Please select either yes or no depending on whether the community has a plan for managing donations during disasters. Key aspects to consider in this plan include accepting, controlling, issuing donation receipts, redistributing and storage of donated goods.

- Yes
- No

26. How many joint meetings have been conducted over the past 3 years between members of all levels of government to discuss emergency preparedness? *

27. Has the community conducted an audit of activities related to emergency preparedness? *

- Yes
- No

28. What is the orientation of the implementation pattern for disaster relief in the community? *

In a bottom-up system relief starts at the local level, if the magnitude of the emergency exceeds the capabilities at the local level then the next level of government becomes involved to mobilize and coordinate activities. In a top-down system the federal government takes over all emergency management activities, the national government becomes the focal point of the relief operation.

Moving the slider all the way to the right implies a fully top-down system, while moving it to the left implies a bottom up system. The community may also sit somewhere in between.

 0
29. Has the community's government established committees to deal with emergency preparedness, climate change adaptation, and disaster risk reduction? *

- Yes
- No

30. Does the community have plans and resources to provide crisis counselling after a disaster? *

- Yes
- No

31. Does the community have mutual aid agreements with neighbouring jurisdictions? *

- Yes
- No

Appendix C Community Preparedness Questionnaire Results

This appendix provides the indicator score and utility value for the case of Richmond County, Nova Scotia.

Dimension	Attribute	Indicator	Score	Utility
Communication and Collaboration	Early Warning and Public Information	Early Warning Systems	12	0.600
		Public Information Management	6	0.234
		Populations at Risk	6	0.091
	Community Collaborative Networking	Volunteer Participation	2	0.400
		Social, Cultural and faith based Groups	4	0.800
Monitoring and Forecasting	Data Collection and Management	Data Collection	1	0.111
		After-action Review Process	0	0.000
	Environmental Forecasting	Weather Forecasting Means	4	0.130
		Trained Weather Spotters	1	0.700
	Hazard and Vulnerability Analysis	Infrastructure Safety Audit	7	0.389
		Public Consultations	2	1.000
GIS Flood Mapping and Simulation		2	1.000	
Training, Education and Community Awareness	Capacity Building and Planning	Simulation Exercises	2	0.400
		Developing an Emergency Plan	2	0.298
	Public Awareness	Household Preparedness	6	0.011
		Public Outreach	0	0.000
Emergency Services and Operations	Incident Command Sys.	Incident Command System	1	1.000
	Emergency Operations	Emergency Operations Centre	2	1.000
		Infrastructure Maintenance	1	1.000
	Resources	Inventory System	0	0.000
		Equipment and Resource Maintenance	1	0.104
		First Responders	16	1.000
		Shelters and Evacuation	58	0.081
Local Governance and Social Services	Preparedness Funds	Disaster Risk Reduction Budget	1	0.200
		Donation Management	0	0.000
	Jurisdictions	Joint Meetings	2	1.000
		Audit of Activities	1	1.000
		Judged Orientation	0.25	0.177
		Committees of the Whole	1	1.000
	Humanitarian and Mutual Aid	Crisis Counselling	0	0.000
		Mutual Aid Program	1	1.000

Appendix D Presentation Slides for Table-Top Exercise Facilitation

This appendix contains the facilitation slides used for the Little Anse table-top exercise.

Operation Breakwater

Tabletop Exercise for the Municipality of the County of Richmond Emergency Operations Centre

The Case of Little Anse Breakwater Failure

Introduction

- ◆ Roundtable Introduction
 - ◆ Facilitators
 - ◆ Participants
- ◆ Tabletop Exercise Scope
 - ◆ Hazards
 - ◆ Purpose
 - ◆ Objectives

Operation Breakwater Tabletop EXERCISE (1) Donald MacLellan, 2010. Little Anse

Thursday, May 1
La Picasse, Université Sainte-Anne, Petit-de-Grat, Nova Scotia

Time	
0900 – 0930	Introduction and Exercise Overview
0930 – 1015	Phase 1: Storm Hits
1015 – 1030	<i>Health Break</i>
1030 – 1115	Phase 2: Breakwater Fails
1115 – 1200	Phase 3: Power Outage
1200 – 1300	<i>Lunch Break (Location: TBD)</i>
1300 – 1345	Phase 4: Community Flooded
1345 – 1500	Phase 5: Salinization of Water Sources
1545 – 1515	<i>Health Break</i>
1515 – 1545	Hotwash Debriefing
1515 – 1600	Wrap-up

Schedule

Operation Breakwater Tabletop EXERCISE

Outline of Tabletop Phases

Phase 1	Phase 2	Phase 3	Phase 4	Phase 5
Preparedness / Response	Response	Response	Response	Response / Recovery
Storm Hits	Breakwater Fails	Power Outage	Community Flooded	Salinization of water sources

Operation Breakwater Tabletop EXERCISE (1) Phil Noble, 2014. People run through sea spray in Rhyl, north Wales. <http://mctrouk2.files.wordpress.com/2013/12/1000x69023.jpg?w=649>

Rules for Participants

- ◆ Respond based on the capacity of the community
- ◆ Feel free to be creative and think outside the box
- ◆ There is no right or wrong answer – relax

Operation Breakwater Tabletop EXERCISE (1) Be Ready, 2012. Exercise Management Team. <http://be-ready.com.au/wp-content/uploads/2012/06/Relief-Centre-0961.jpg>

Phase 1: Storm Hits

6:38pm Wednesday January 22nd

- ◆ Environment Canada has issued a winter storm warning for most of Nova Scotia.
- ◆ Heavy snowfall, freezing rain and strong winds are forecasted for the area of Isle Madame. Strong winds of well over 110km/h can be felt and storm tides are battering the coast.
- ◆ Concerns about storm surges and floods are widespread when a low pressure system with strong winds is in the forecast. Several community members have voiced their concern for their safety on social media websites.

Operation Breakwater Tabletop EXERCISE

Weather

Alerts for: Richmond County

Richmond County
6:38 PM AST Wednesday 22 January 2014
Winter storm warning for Richmond County continued

Significant snowfall, freezing rain, blowing snow and winds expected today, tonight and Thursday morning.

This is a warning that dangerous winter weather conditions are occurring in the region of Richmond County. Monitor weather conditions and follow for updated statements.

An intensifying low pressure system developing south of the Maritimes will track northeastward passing east of Nova Scotia tonight before reaching Newfoundland Thursday morning. This disturbance will bring significant snowfall that will turn into ice pellets and freezing rain.

Freezing rain over Isle Madame is expected to persist overnight for another 5 to 6 hours, with freezing rain changing to rain over Eastern Isle Madame early morning. Rainfall accumulations of 30 to 40 millimeters are forecast by Thursday morning. Strong southwesterly winds are expected to develop overnight with gusts between 80 and 110 km/h.

Operation Breakwater Tabletop EXERCISE (1) Environment Canada, 2014. Weather alert banner. Edited 7

Activate Emergency Operations Centre

- At 9:30pm the Municipality of the County of Richmond has decided to activate their EOC in Arichat.
- Who is authorized to activate the EOC? When should the EOC be activated?
- What level of activation is needed for the given situation? Who would be involved at this level of activation?
- Where should the EOC be situated? Are there alternative locations?

Operation Breakwater Tabletop EXERCISE (1) Madison County EMA, Emergency Operations Center. <http://www.madisoncountyma.com/ops.htm> 8

Alert Community

- At this point, this winter storm has been deemed to cause significant damage as seen with the communities in Southern Nova Scotia that currently in the midst of the storm.
- It is now close to 10:57pm and the areas facing significant risks should be alerted.
- There have been reports of large chunks of ice are battering the breakwater in Little Anse and it could break any moment now.

Operation Breakwater Tabletop EXERCISE (1) Glenn Bennett, 2011. The Casso Causeway during a winter 2011 storm. 9

Discussion Questions

- When and how should the community be notified? Should a state of emergency be declared (keep in mind continuity of operations)? Who is responsible for this?
- Who are the media partners? Are there scripted messages or templates to ensure the necessary information is delivered? If not please provide a sample message for the given situation.
- What other organizations would need to be notified at this stage of the storm?

Operation Breakwater Tabletop EXERCISE 10

Phase 2: Breakwater Fails (Roads Flood)

12:30am Thursday January 23rd

- Shortly after midnight, the breakwater gives out after hours of being battered by strong winds and storm surges.
- The onrush of water into the cove washes out the road and several homes along shore. The main road leading into Little Anse is no longer accessible.

Operation Breakwater Tabletop EXERCISE (1) Greg Kretovic, 2013. Winter storm moving over Lake Superior. <http://midnightnaturephotos.photoshelter.com/imgage/I0000b11msw3k3v56Q> 11

Respond to Fallen Tree Damaging House and Power Lines

- Strong winds and wet snow have caused a tree to topple onto a corner of the house located on Morrison Drive, wiping out the power lines in the process.
- There is at least one casualty when the tree took out a corner of the house. Neighbours are currently attending to the injured elderly woman - however she needs medical aid immediately.

Operation Breakwater Tabletop EXERCISE (1) Sandy Larson, 2010. Tree went down on the power lines going into the house. <http://minnesota.ohlocal.com/2010/11/13/first-snow-of-season-wallops-ewitches/> 12

Map

Operation Breakwater Tabletop EXERCISE (1) Google Maps, 2014. Little Anse Community N.S. 13
 (2) Google Maps, 2014. Richmond County N.S.

Discussion Questions

- ◆ Who is needed to respond to this event (restoring power, securing the area, alerting the community to avoid the area, removing the tree)? What type of equipment will need to be deployed?
- ◆ How will emergency triage be carried out?
- ◆ How will those affected be able to withstand the cold weather without heat in a damaged home? Will a generator be provided or will they be evacuated? (If evacuated, where can they go?)

Operation Breakwater Tabletop EXERCISE 14

Respond to Media Request for Information

- ◆ Members of the media (Telile, The Hawk, CBC Radio, The Reporter, Cape Breton Post and St. Peter's Cable) have been pressing the EOC for more information.
- ◆ In fear of letting the situation get out of hand, a media centre or method of information dissemination needs to be set up.

(1) New York City, 2012. Mayor Michael Bloomberg holds a briefing on Hurricane Sandy. <http://www.theguardian.com/world/blog/2012/oct/29/hurricane-sandy-his-on-east-coast-live>

Operation Breakwater Tabletop EXERCISE 15

Discussion Questions

- ◆ Where should the media centre be set up?
- ◆ Who is responsible for addressing the media?
- ◆ What information should the public be aware of at this point in time?

(1) Donald MacLellan, 2010. Petri de Grat Packers Ltd, crab plant wharf

Operation Breakwater Tabletop EXERCISE 16

Respond to Child Who Has Not Returned Home

- ◆ It is now 1:20am and dispatch has received a call from panicked parents about a missing child.
- ◆ A 15 year old girl who was going to spend the night at her friend's house (located on Cypers Lane) decided to head back home at around 10pm to beat out the storm but it has now been almost 4 hours and her parents have not heard from her.
 - ◆ What organizations can be contacted to assist with this situation?
 - ◆ Should the community be alerted and if so, how will this be done?
 - ◆ What are the possibilities of organizing a volunteer search operation?

Operation Breakwater Tabletop EXERCISE 17

Phase 3: Power Outage

3:33am Thursday January 23rd

- ◆ Strong winds continue into the early morning hours and heavy snow causes trees to topple and knock out the majority of power lines in the community.
- ◆ Little Anse is left with no electricity in freezing conditions as the water creeps further up the shoreline.

(1) Melanie Lynn Ingersoll, 2013. Flooding near Liverpool, N.S. <http://www.cbc.ca/news/canada/new-scotia/storm-surge-floods-coastal-nova-scotia-1.1308403>

Operation Breakwater Tabletop EXERCISE 18

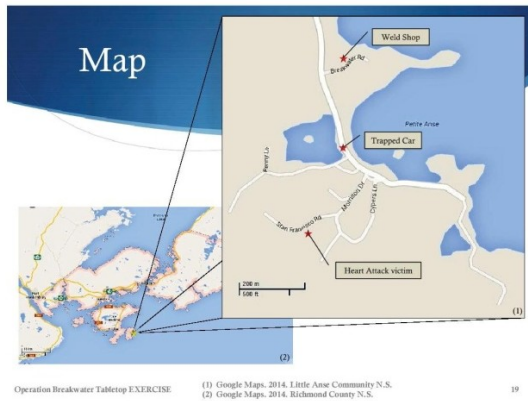

Respond to Car Washed Off Road

- At 4:10am a call came in for a car trapped on the flooded road. A man in his 70s was trying to drive further inland and out of the Little Anse side of the cove to take shelter from the storm.
- His car broke down on the flooded road and now strong surges have pushed the car into the brackish pond with him trapped inside.
- There are concerns of hypothermia if he is not rescued soon.



Discussion Questions

- Who can be deployed to respond and what equipment would be needed?
- Who will be responsible for closing off the road and alerting the community? How will the road be closed off?
- Where can the victims be treated or transferred?

Respond to Heart Attack Victim

- The road leading into the community of Little Anse has washed out and immediate medical attention is needed for an elderly man suffering from a heart attack on the Little Anse Community side of the cove.



Discussion Questions

- Who can be deployed in this situation? What resources can be used and where are they located? Are there community volunteer responders are trained for this situation?
- What alternative routes can be taken to reach the scene now that the road has been washed out?
- How will the man be safely transported and to where can he be treated?

Contain Hazardous Materials in Flooded Weld Shop

- Vernie J. Martell Welding & Industrial Welding located on Breakwater Road has several oxy acetylene and propane tanks that could pose as a threat. This is an issue that needs to be addressed immediately before the building collapses.
 - What methods can be employed to contain the oxy acetylene tank? Who can be deployed to carry out this task?
 - What type of equipment is required?
 - What safety measures are utilized? Should neighbouring homes be evacuated?

Phase 4: Community Flooded

6:09am Thursday January 23rd

- ◆ High winds, waves and tides continue to lash the coastal community of Little Anse. Surge levels have reached a height of 2m and the majority of the community is flooded.
- ◆ Many community assets have been damaged in the process, including the entire wharf, 8 buildings, and 32 houses.



Operation Breakwater Tabletop EXERCISE (1) Susan MacMillan, 2013. Fish house near near Corlamm Island, Lunenburg County, N.S. <http://www.dfo.ca/news/canada/nova-scotia/storm-surge-floods-coastal-nova-scotia-1.1300403> 25

Evacuate Community

- ◆ As the storm continues to batter the coast and flood communities up the Eastern shore line, Richmond County will need the aid of neighbouring jurisdiction.
- ◆ Resources are now depleted and responders are exhausted after being on the job for the past 12 hours.

7:02am Thursday January 23rd

- ◆ Surge levels have reached an unprecedented height of 2m. The majority of homes have flooded and an evacuation order is issued. Conditions are no longer bearable due to the freezing temperatures, downed power lines, and flooded homes.

Operation Breakwater Tabletop EXERCISE 26

Discussion Questions

- ◆ How will community members be alerted about an evacuation order? Who is responsible for ensuring that everyone is evacuated? Is there a method to account for everyone?
- ◆ Where are the shelters located and are they capable of handling the number of people expected to arrive? How many are expected to arrive?
- ◆ What method of transportation is available to evacuate community members (e.g., buses, boats, car pool program)? Are community members required to find modes of transportation themselves?

Operation Breakwater Tabletop EXERCISE 27

Respond to Woman and Her Two Children Left Behind

- ◆ Shortly after opening the evacuation centre at 7am, responders were approached by a man who said his sister is nowhere to be found.
- ◆ She is physically impaired may not have heard the evacuation orders issued via radio. He is starting to panic and wants responders to go back into Little Anse to find her and her two young children.

Operation Breakwater Tabletop EXERCISE 28



Operation Breakwater Tabletop EXERCISE (1) Google Maps, 2014. Little Anse Community N.S. (2) Google Maps, 2014. Richmond County N.S. 29

Discussion Questions

- ◆ What is the best course of action to take? Should someone be deployed and if so who? What resources will they need?
- ◆ How will responders communicate with the woman?
- ◆ What accommodations can be made for the population at risk during evacuation and sheltering?



Operation Breakwater Tabletop EXERCISE (1) Adam Hinger, 2012. Residents are rescued by emergency personnel. <http://catholicphilly.com/media-files/2012/10/sandy1.jpg> 30

Phase 5: Salinization of Potable Water Sources

9:43am Thursday January 23rd

- The storm has died down but the aftermath is clearly visible.
- The storm left a path of destruction through the coastal community - claiming 3 fatalities, 7 injured and hundreds without a home.
- The flood water left behind has raised concerns about public health issues. Also, the community has 45 wells and 16 have been damaged by the storm. Potable water is scarce in the community and citizens are uneasy about returning home.

Operation Breakwater Tabletop EXERCISE

31

Provide Social Services and Counselling at the Shelters

- As the morning progresses more and more people check in at the emergency shelters.
- Spirits are down in the community and everyone is mentally exhausted from the overnight ordeal. Many are distraught and it is clear that they need crisis counselling.



(1) Jordan Verlage, 2013. Displaced residents sleep on cots at the arena in Blackie, Alta. <http://www.cbcnews.ca/canada/three-confirmed-dead-in-alberta-flooding-as-evacuations-continue-1.133530#1.133530>

Operation Breakwater Tabletop EXERCISE

32

Discussion Questions

- What types of services are needed? What types can you provide as a community?
- How will you address food, clothing, lodging, registration and information, and personal services?
- What organizations can assist in this situation? What are their capabilities?



Operation Breakwater Tabletop EXERCISE

(1) Donald MacLellan, 2010. Little Anse

33

Address Public Health Issues from Flood Water

- Homes were destroyed, roads were severely damaged, and key infrastructures (e.g., utility lines, water mains, and wells) were lost.
- A major concern now is water-borne diseases that may be present in the ocean water, including ballast water from off-shore vessels and sewage.
- A secondary concern is the contamination of potable water sources due to saltwater encroachment. With 16 wells destroyed, potable water is scarce in the community and must be addressed before residents can return.

Operation Breakwater Tabletop EXERCISE

34

Discussion Questions



- What preventative measures have been discussed for this situation?
- How will the community cope without a source of clean water for several days?
- What measures can be taken to limit disease outbreaks from waste water and mould from the flood.

Operation Breakwater Tabletop EXERCISE

(1) Donald MacLellan, 2010. Little Anse

35

Respond to Criticism from Community and Media Members

- Community members say they are furious that local government officials did not take proper precautions to ensure safety ahead of a storm that left 3 people dead, 7 injured and many people from the community displaced.



- What statement can be given to the media post storm?
- How will the community reach out to those affected?
- How can the community develop and implement best practices for future emergency events?

Operation Breakwater Tabletop EXERCISE

(1) Donald MacLellan, 2010. Little Anse

36

Hotwash Debrief

"A discussion between participants and members of the exercise facilitation team to discuss preliminary observations immediately following the exercise"



Operation Breakwater Tabletop EXERCISE (1) D. M. S. Phillip, 2008. A single home is left standing among debris from Hurricane Ike. <http://earthchangenews.com/publish/article-9162522930.php> 37

Thank You



Appendix E Detailed Event Decision Trees

This appendix contains the decision trees for the nine detailed event discussed in Section 6.2 – Decision Making Under Risk in Little Anse. The trees were generated using TreePlan Decision Tree software.

Event 1 - Alert Community

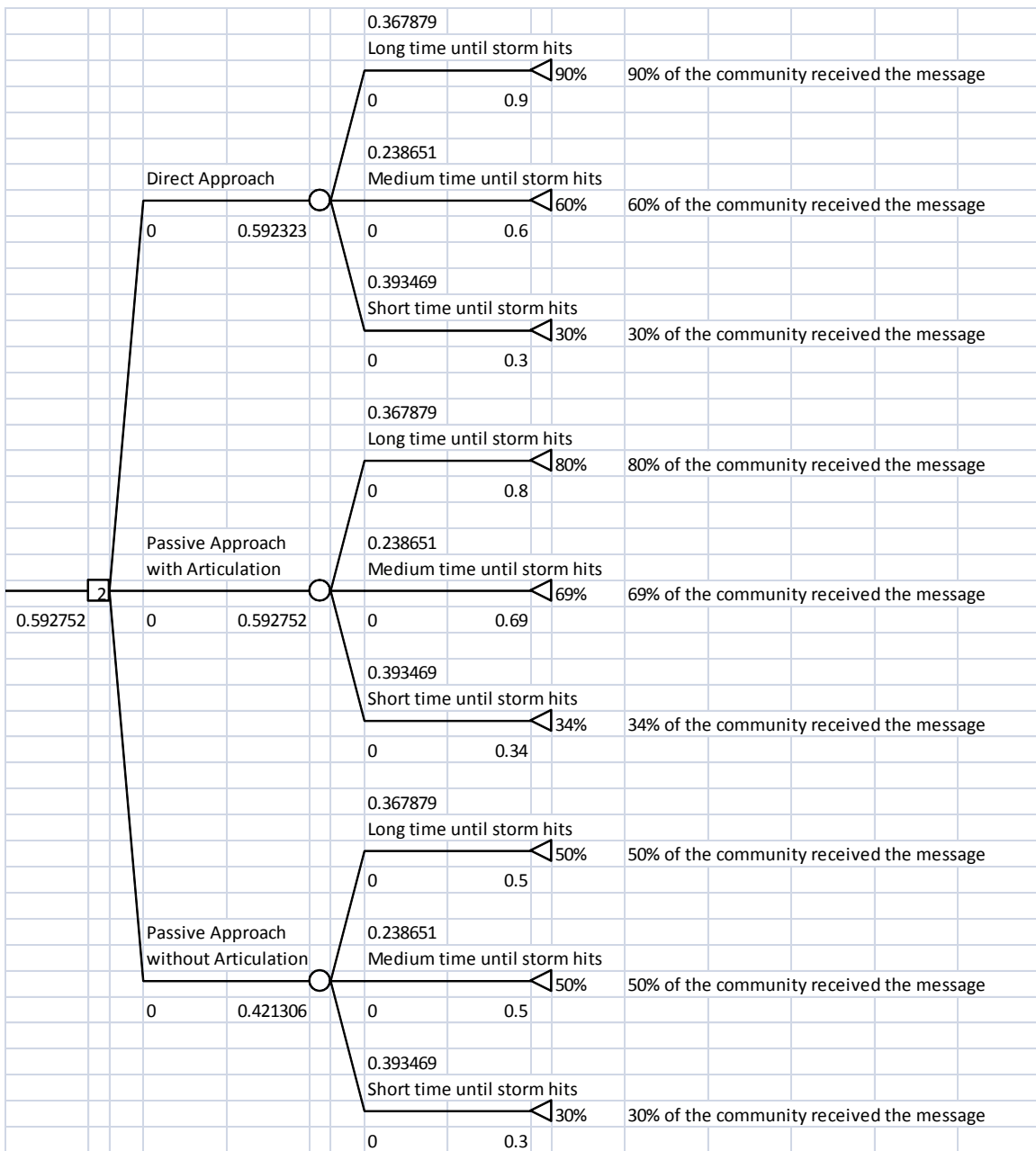

Event 2 - Fallen Tree

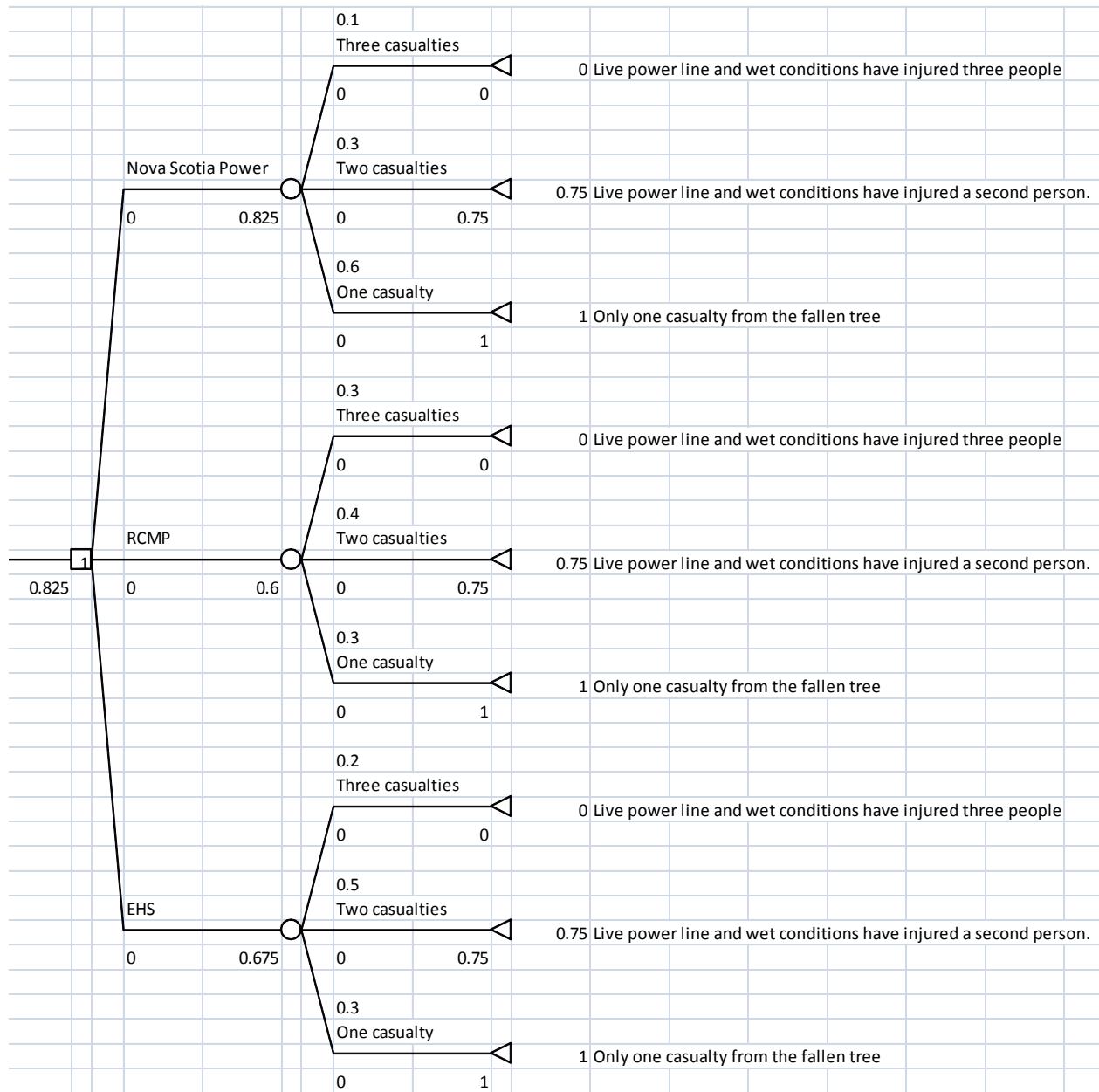

Event 4 - Lost Child

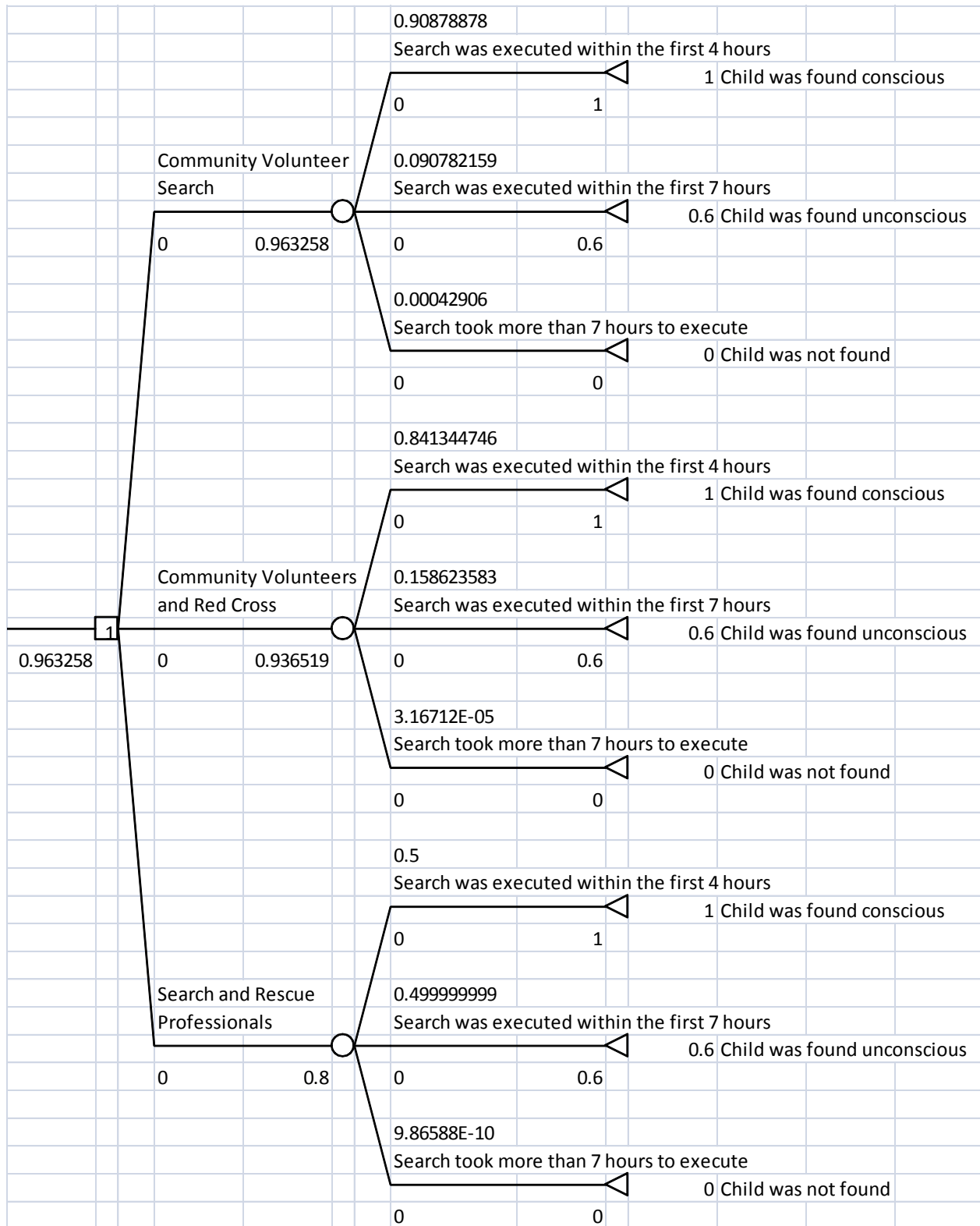

Event 5 - Mobility Issues

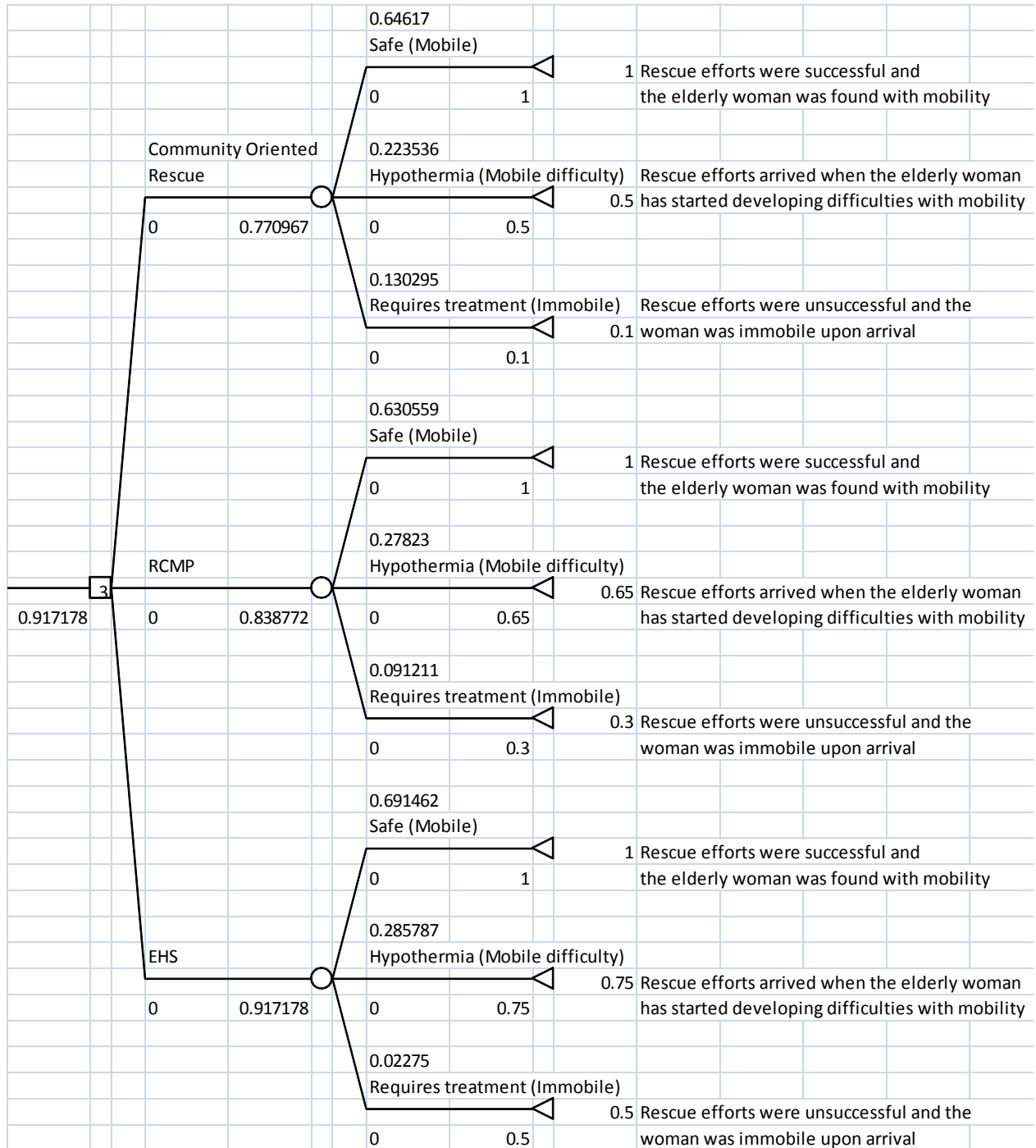

Event 6 - Hazardous Materials

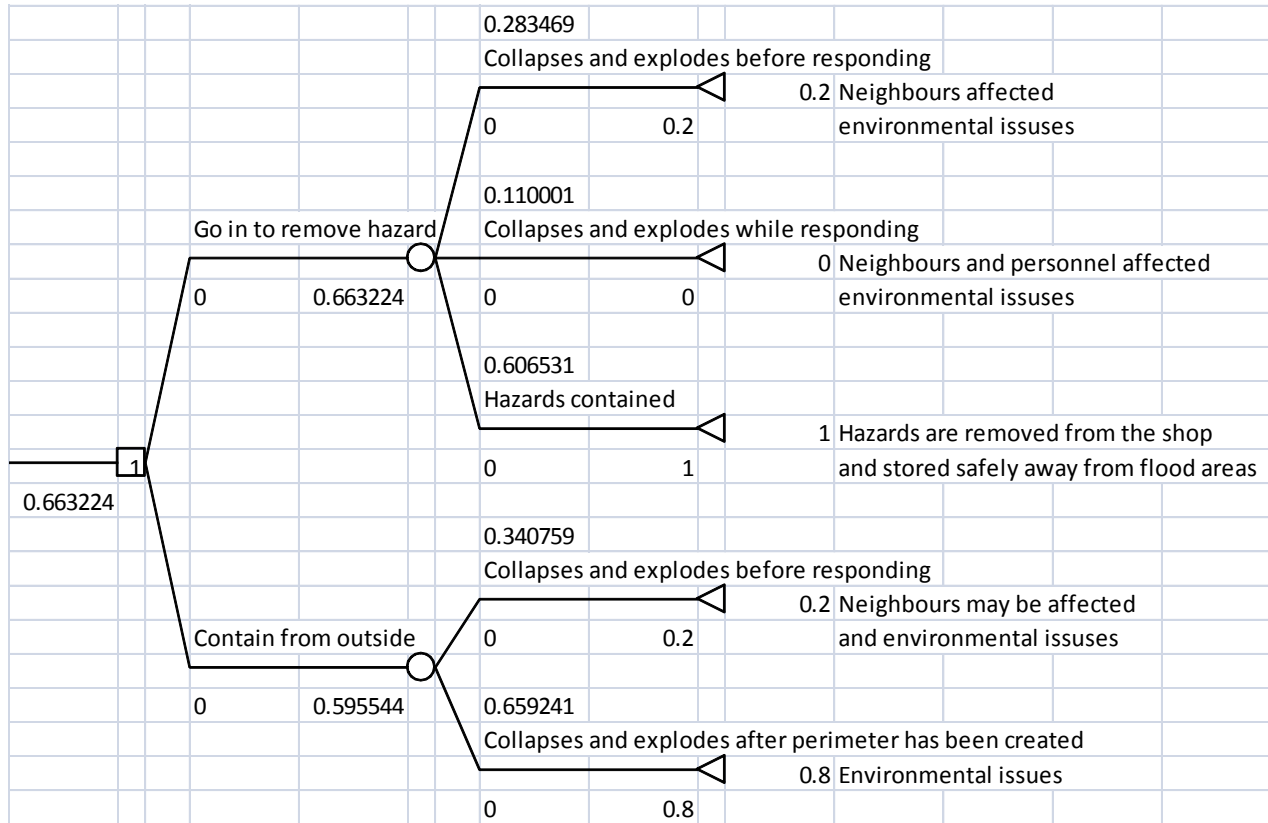

Event 7 - Evacuate

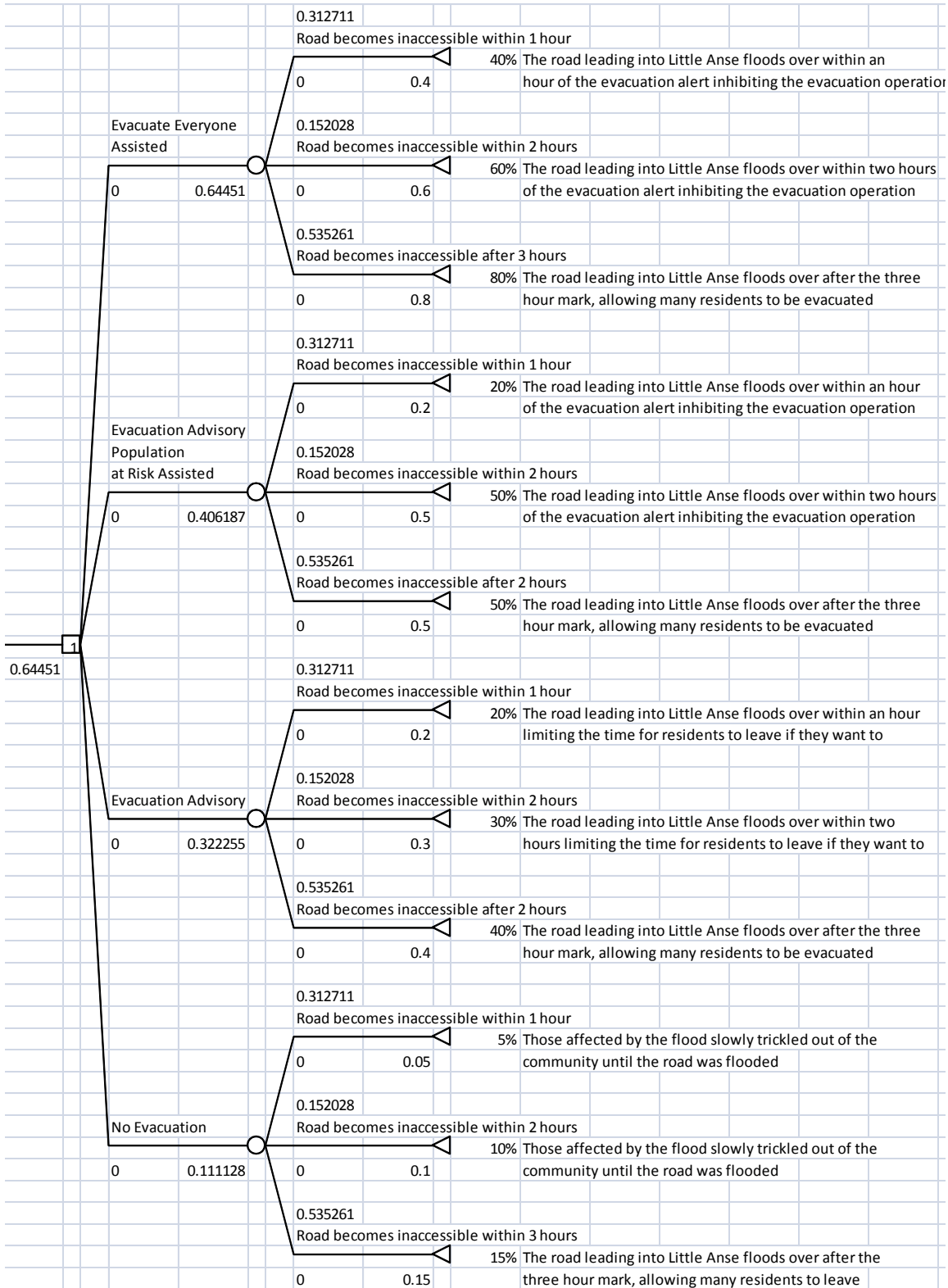

Event 8 - Heart Attack Victim

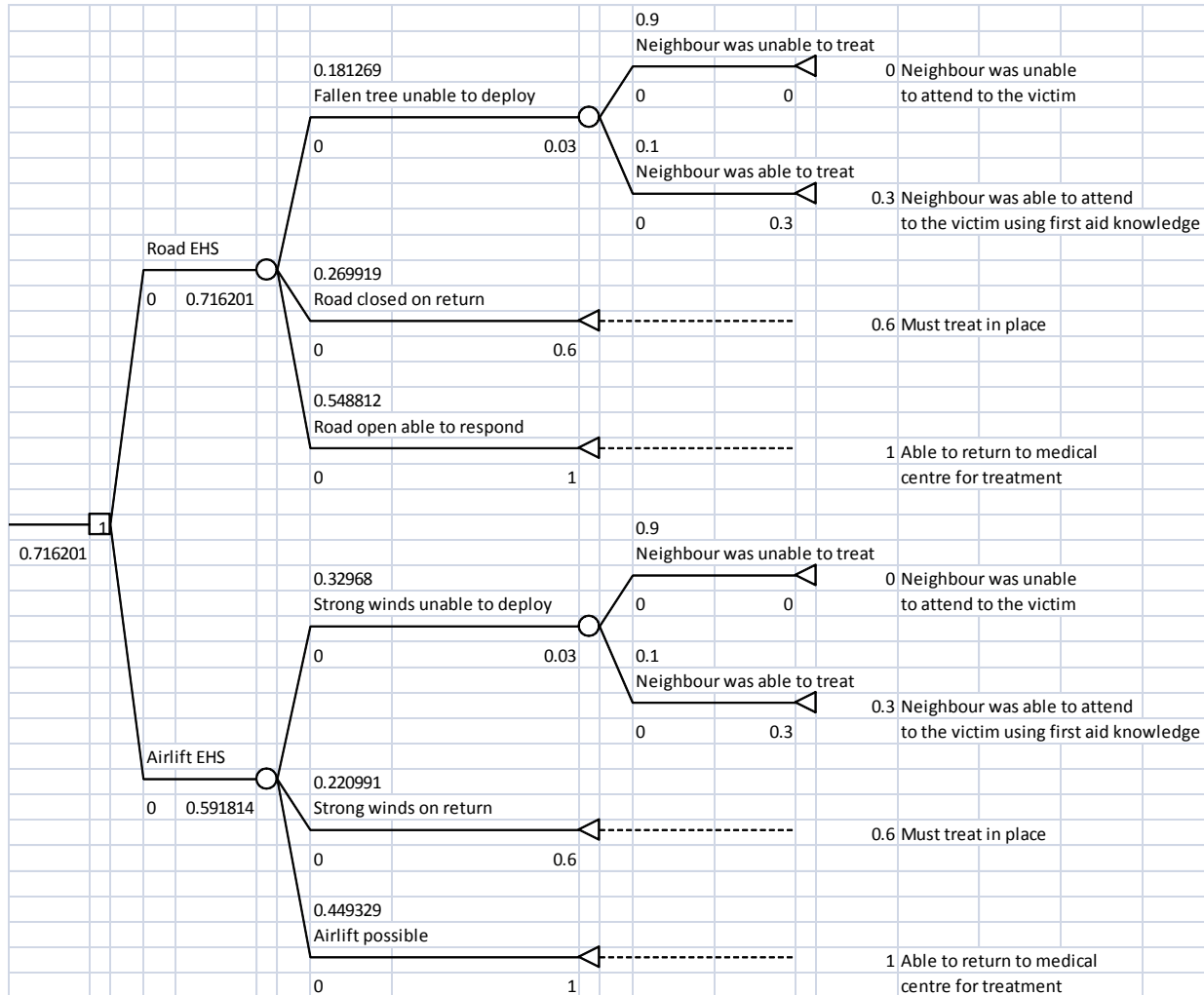

Event 9 - Public Health

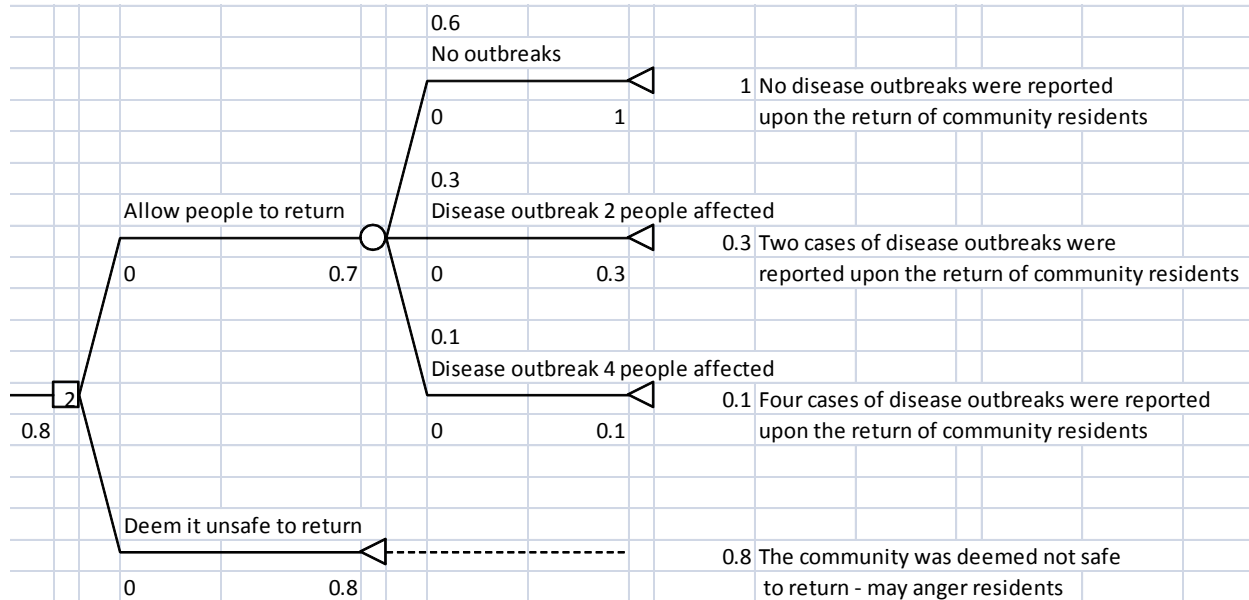

Appendix F *Arena* Simulation Model

This appendix displays the screenshots of the *Arena* simulation models for the nine events. Each event is shown with two timelines – a storm event timeline (across the top) and response timeline (across the bottom).

Event 1 – Alert Community

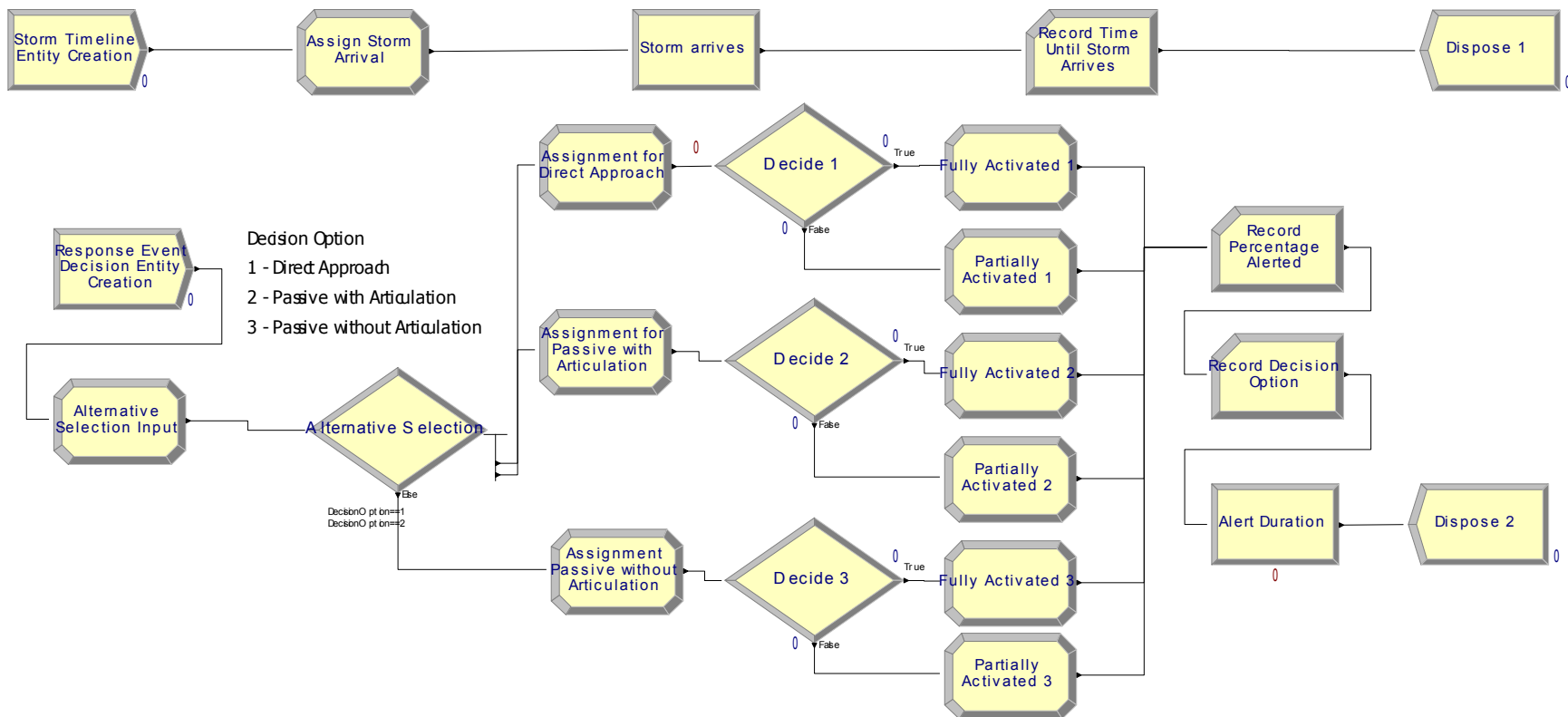

Event 2 – Fallen Tree

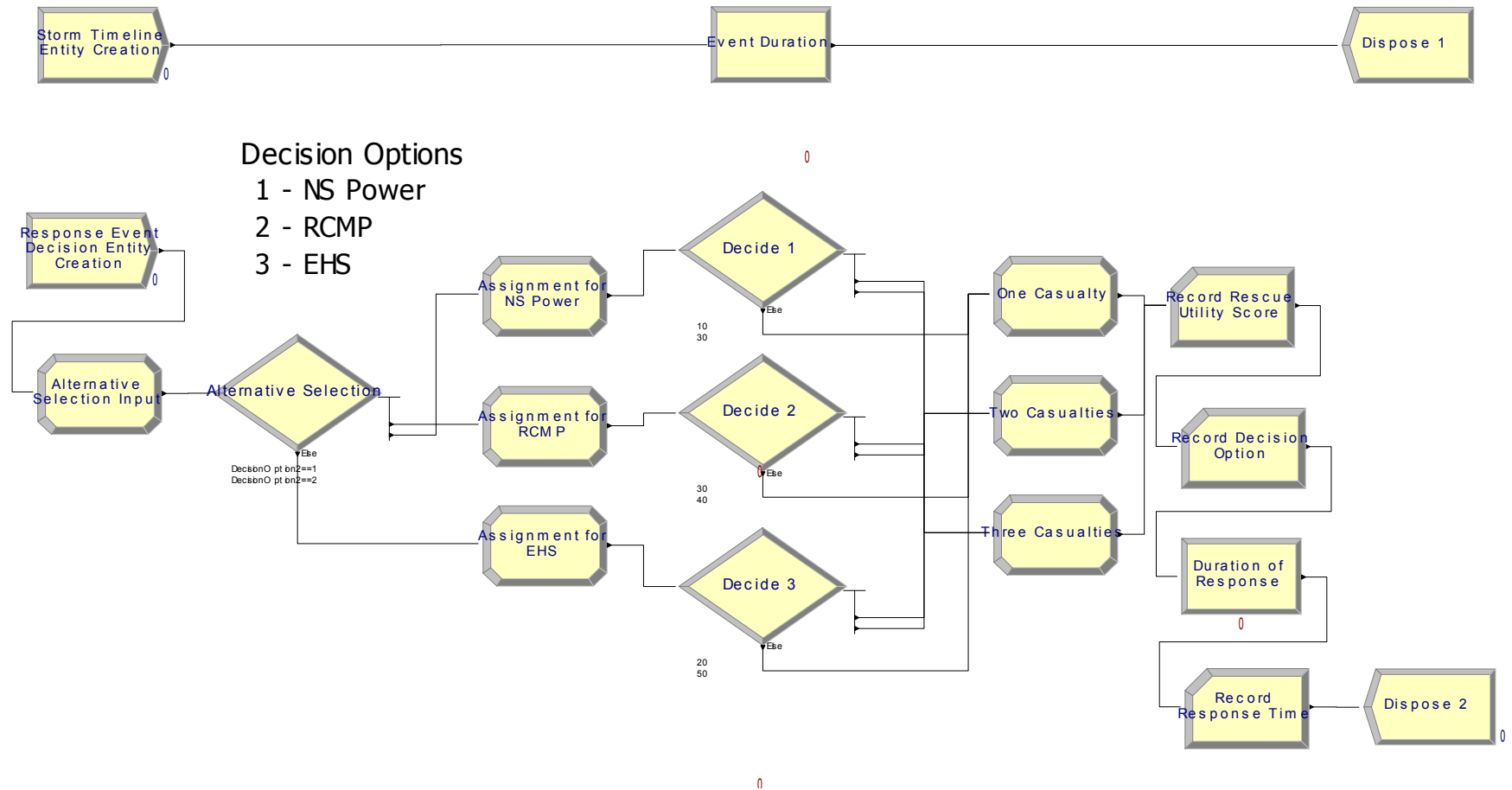

Event 3 – Trapped Car

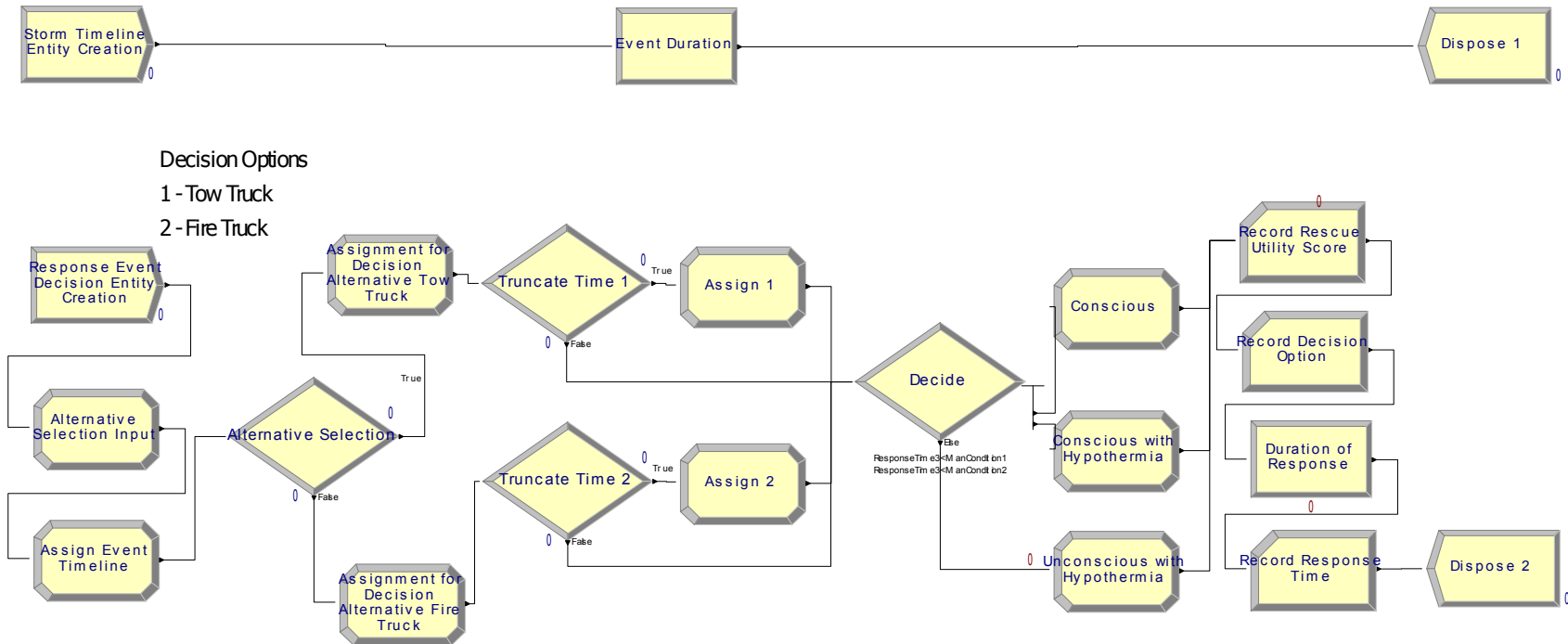

Event 4 – Lost Child

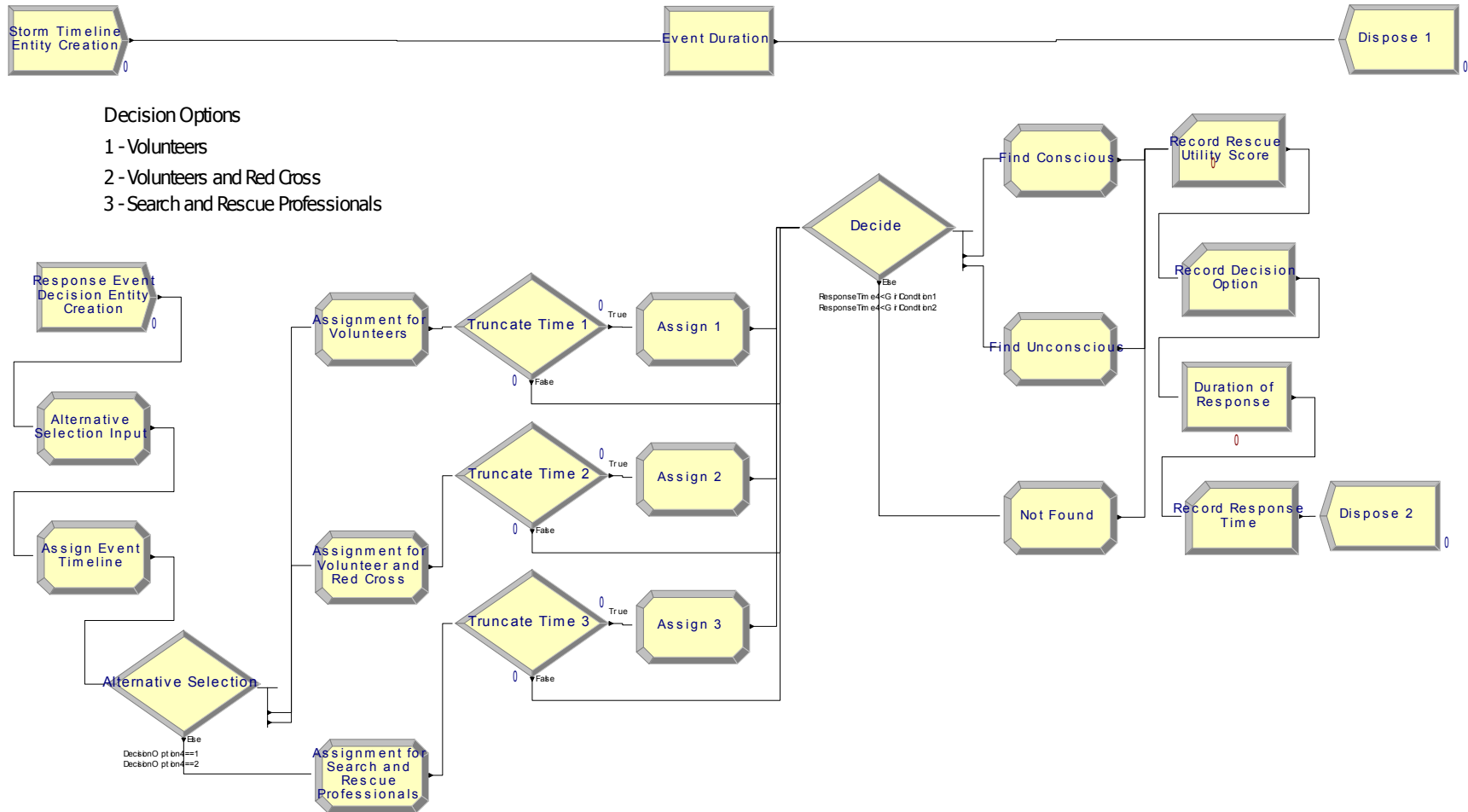

Event 5 – Mobility Issues

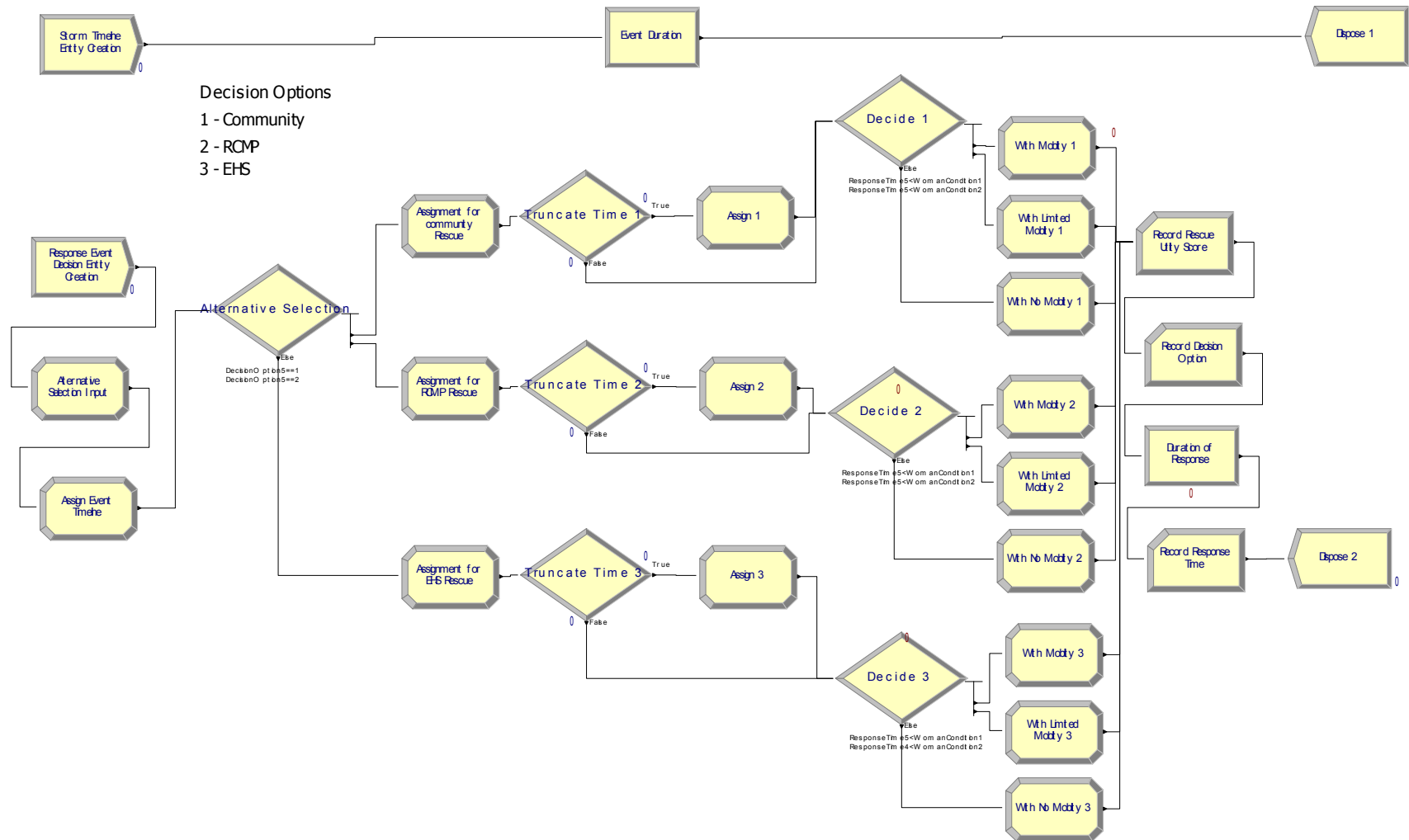

Event 6 – Hazardous Materials

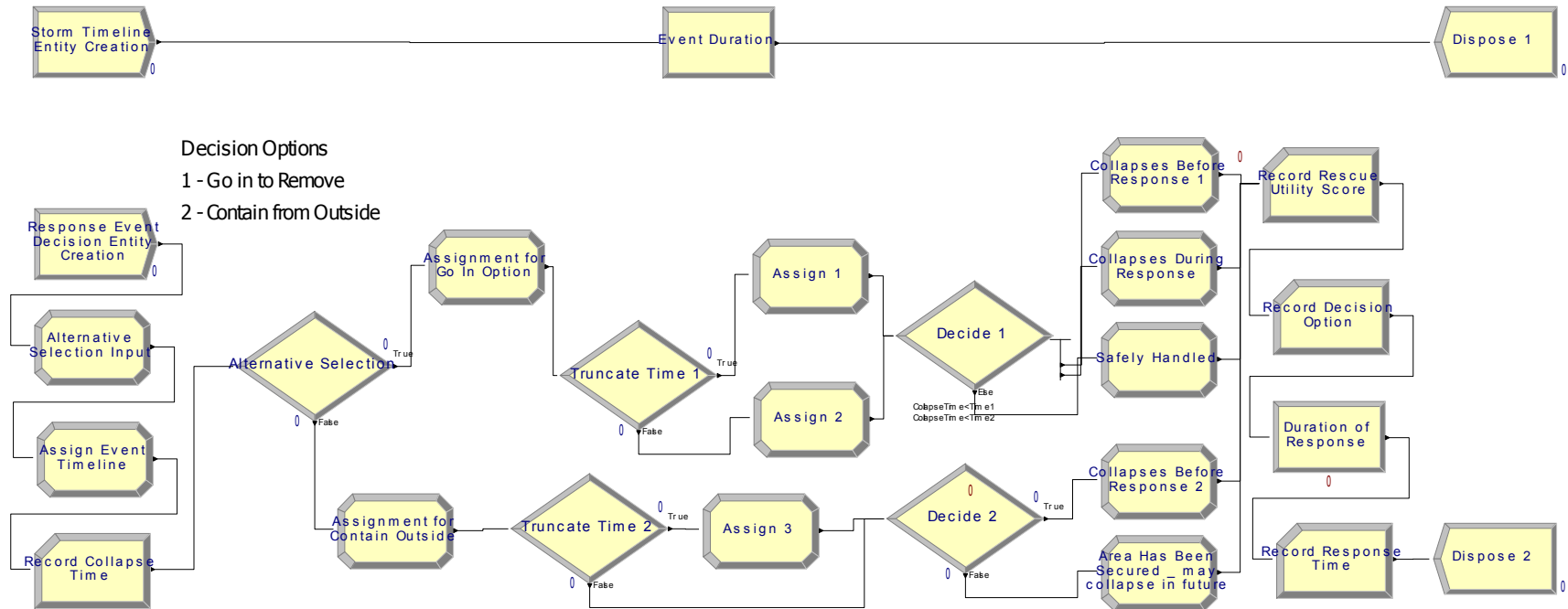

Event 7 – Evacuation

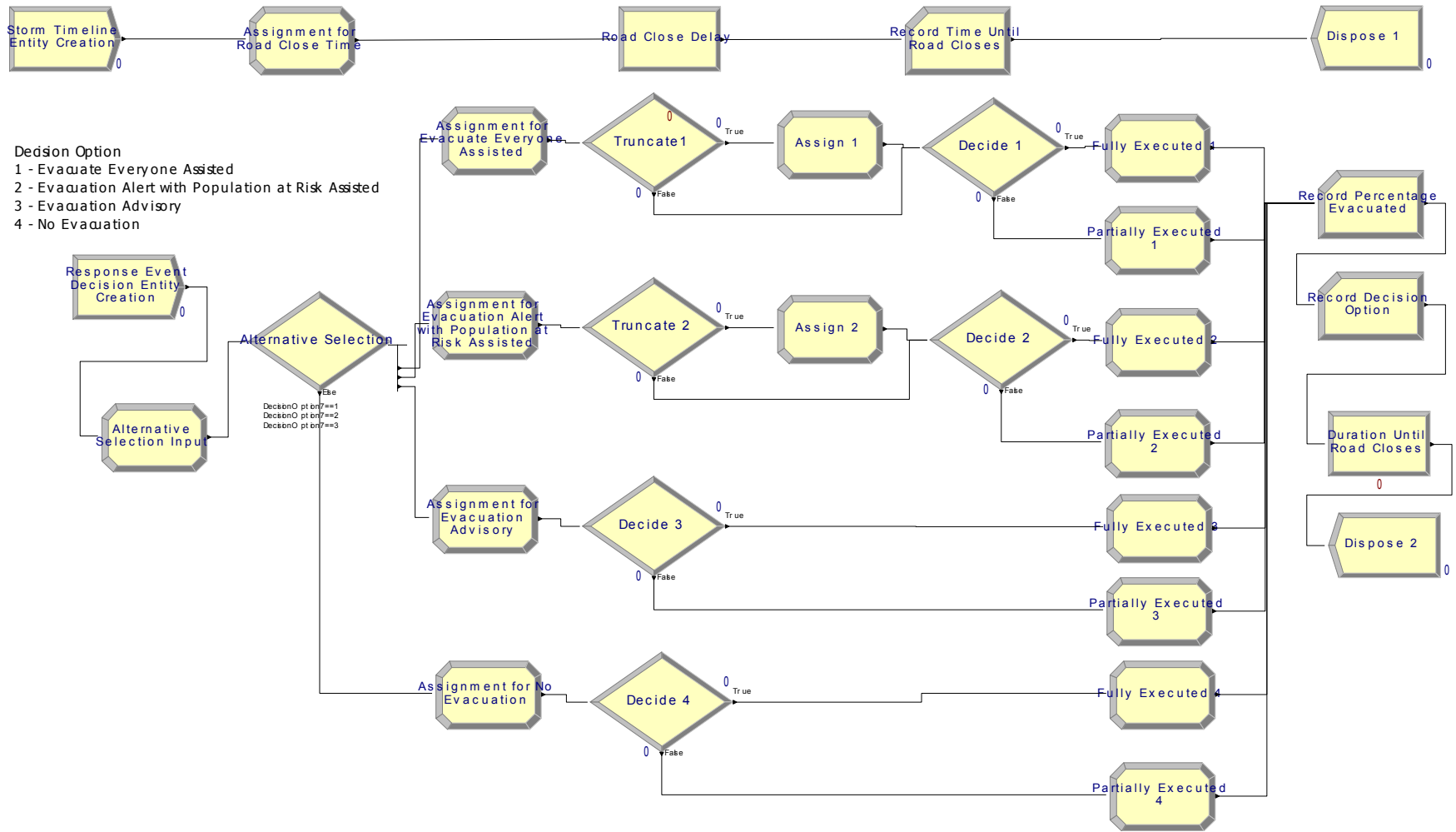

Event 8 – Heart Attack Victim

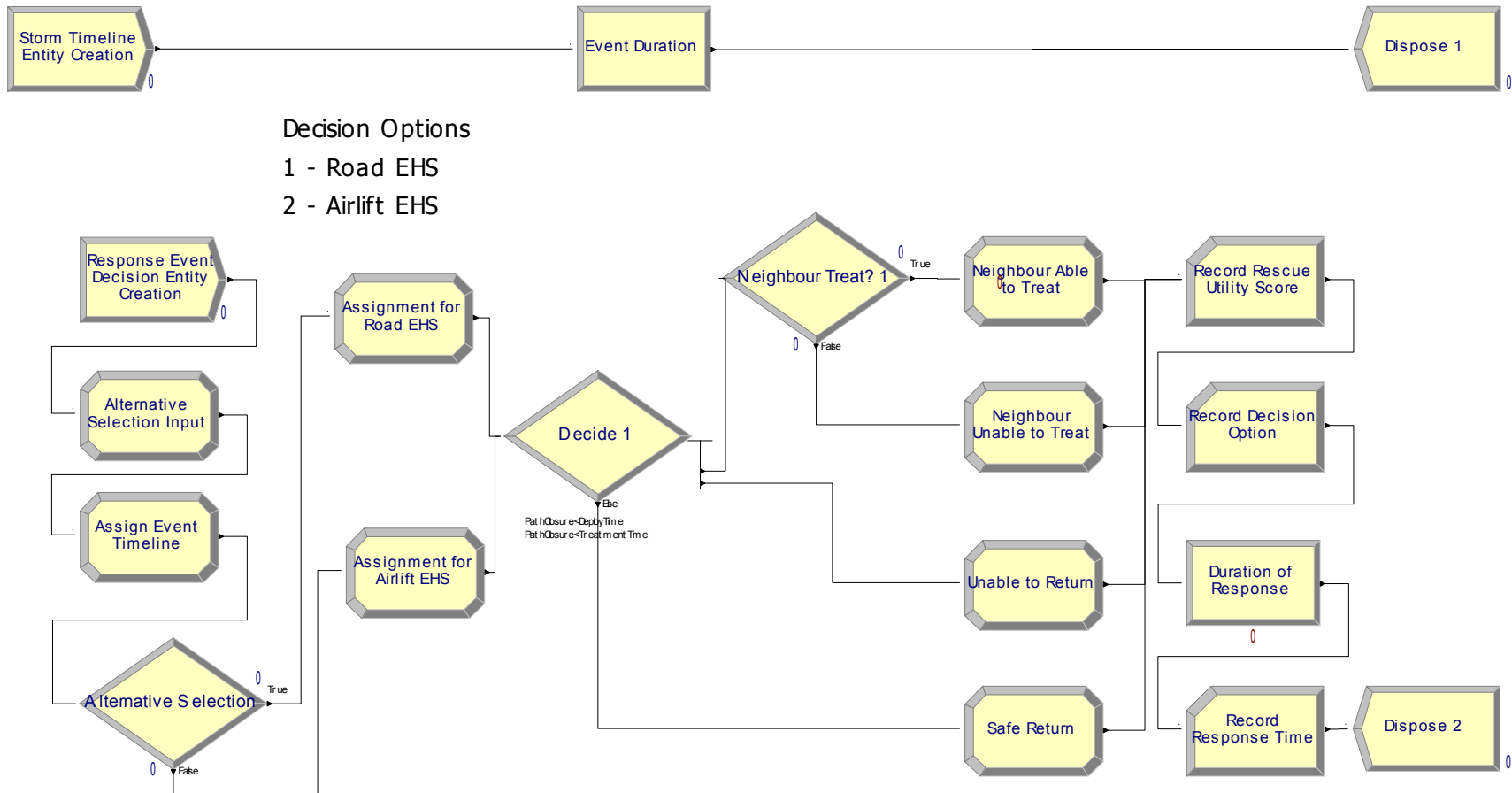

Event 9 – Public Health Issue

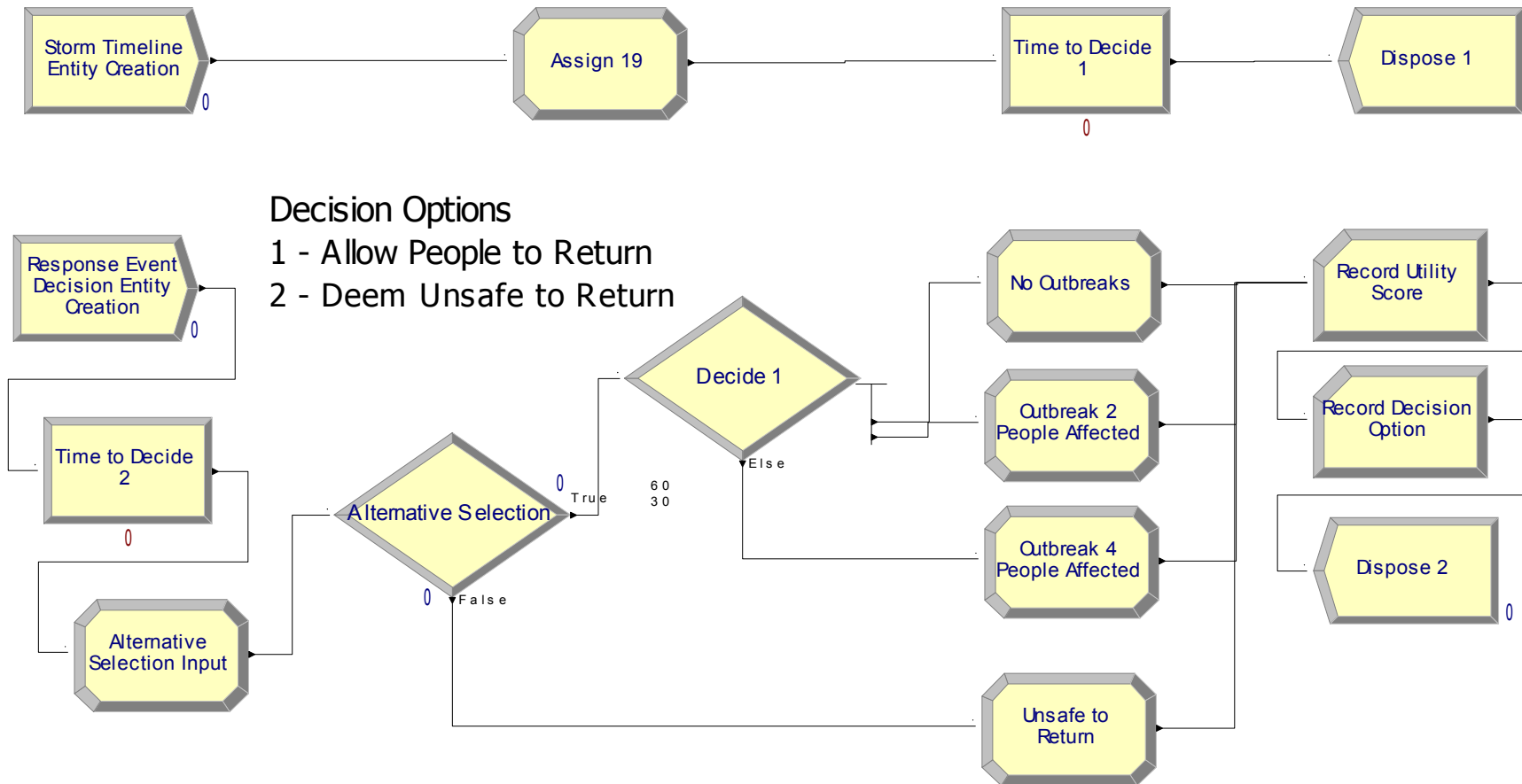

Appendix G *Arena* Simulation Model Output Summary

This appendix provides the summary of outputs following the *Arena* simulation. The means and standard deviations (SD) were calculated for each recorded entity and variable of interest in the model. Three strategies were presented: random decisions, intra-community, and extra community.

Events	1	2	3	4	5	6	7	8	9
Random Decision Making	Alert	Fallen Tree	Trapped Car	Lost Child	Mobility Issues	HAZMAT	Evacuate	Heart Attack	Public Health
Count Decision Option 1	6	6	8	6	6	8	4	8	4
Count Decision Option 2	2	2	2	2	2	2	4	2	6
Count Decision Option 3	2	2		2	2		0		
Count Decision Option 4							2		
Mean Time Until Storm Arrives	10.549								
SD of Time Until Storm Arrives	11.302								
Mean Percentage Alerted	38.894								
SD of Percentage Alerted	35.892								
Mean of Response Time		0.873	1.734	2.226	1.305	1.577		1.605	
SD of Response Time		0.807	1.101	1.129	1.021	1.506		1.285	
Mean of Utility Score of Rescue		0.900	0.710	0.860	0.780	0.680		0.760	0.880
SD of Utility Score of Rescue		0.129	0.398	0.327	0.290	0.253		0.420	0.103
Mean of Collapse Time						5.243			
SD of Collapse Time						4.922			
Mean of Percentage Evacuated							37.726		
SD of Percentage Evacuated							32.726		
Mean of Time Until Road Closes							3.516		
SD of Time Until Road Closes							3.767		

Events	1	2	3	4	5	6	7	8	9
	Alert	Fallen Tree	Trapped Car	Lost Child	Mobility Issues	HAZMAT	Evacuate	Heart Attack	Public Health
Intra-community Decisions									
Decision Option	1	3	2	1	1	2	3	1	1
Mean Time Until Storm Arrives	10.549								
SD of Time Until Storm Arrives	11.302								
Mean Percentage Alerted	42.050								
SD of Percentage Alerted	37.204								
Mean of Response Time		0.147	2.455	2.682	1.752	1.240		0.981	
SD of Response Time		0.166	0.838	1.256	1.551	1.345		0.780	
Mean of Utility Score of Rescue		0.750	0.380	0.640	0.580	0.500		0.520	0.520
SD of Utility Score of Rescue		0.408	0.410	0.386	0.397	0.316		0.473	0.421
Mean of Collapse Time						1.763			
SD of Collapse Time						1.997			
Mean of Percentage Evacuated							23.572		
SD of Percentage Evacuated							16.772		
Mean of Time Until Road Closes							3.516		
SD of Time Until Road Closes							3.767		

Events	1	2	3	4	5	6	7	8	9
	Alert	Fallen Tree	Trapped Car	Lost Child	Mobility Issues	HAZMAT	Evacuate	Heart Attack	Public Health
Extra-community Decisions									
Decision Option	3	1	1	3	2	1	2	2	2
Mean Time Until Storm Arrives	10.549								
SD of Time Until Storm Arrives	11.302								
Mean Percentage Alerted	36.756								
SD of Percentage Alerted	20.095								
Mean of Response Time		0.441	2.002	3.500	1.714	1.240		1.329	
SD of Response Time		0.499	1.551	0.000	1.209	1.345		1.341	
Mean of Utility Score of Rescue		0.775	0.520	0.500	0.650	0.500		0.520	0.800
SD of Utility Score of Rescue		0.416	0.371	0.380	0.286	0.316		0.473	0.000
Mean of Collapse Time						1.763			
SD of Collapse Time						1.997			
Mean of Percentage Evacuated							34.891		
SD of Percentage Evacuated							20.887		
Mean of Time Until Road Closes							3.516		
SD of Time Until Road Closes							3.767		