

# **Seismic Risk Assessment of Wood Frame Construction Using Fuzzy Based Techniques**

By  
**Sajjad Ghorbani Komsari**

A thesis submitted to the  
Faculty of Graduate and Postdoctoral Studies  
in partial fulfillment of the requirements for the degree of

**Master of Applied Science**

in Civil Engineering

Ottawa-Carleton Institute for Civil Engineering

Department of Civil Engineering

University of Ottawa

May 2014

# Abstract

---

Wood-framed buildings have generally performed well during earthquake events, resulting in low fatality levels. However, various degrees of damage is still observed in these buildings during previous earthquakes. Lessons learned from the performance of wood frame construction in these earthquakes is led to an improvement in the design codes and construction practices over the past decades. But, the existing buildings are still vulnerable, since they were designed based on the older codes or constructed using old construction practices. Wood frame construction is the most common construction type in Canada, especially for single family dwellings. Most of these buildings are old, built prior to any modern seismic requirement, and have not been retrofitted against the damaging effects of earthquakes. Therefore, with a number of Canadians living in areas of high or moderate earthquake risk, there is a need to develop tools to assess the seismic vulnerability of the exiting wood-framed buildings in Canada.

In the following thesis, a risk-based visual seismic assessment model and a screening tool (CanRisk) is developed, to assess the seismic vulnerability of existing wood frame construction in Canada. The model is dependent on the seismic hazard, building vulnerability, and building importance/exposure, which are integrated using hierarchical fuzzy rule based modeling. In the proposed seismic assessment model, fuzzy logic is used as a computing technique to capture the vagueness and uncertainty of a seismic vulnerability assessment, caused by subjectivity involved in the evaluation process. The hierarchical fuzzy rule based modeling used in this seismic assessment method is implemented in a prototype Matlab based program (CanRisk), which incorporates the Canadian seismic design practice based on the National Building Code of Canada (NBCC) and the Canadian site seismic hazard.

A sensitivity analysis is conducted to test and verify the seismic assessment model and investigate the effects of various parameters on the outcome of the assessment. Also, in a case study, selected wood-framed buildings located in the city of Ottawa are evaluated using CanRisk, to demonstrate the applicability of the program.

## Acknowledgements

---

First and mostly, I wish to express my gratitude to my supervisors, Dr. Ghasan Doudak and Dr. Murat Saatcioglu, for their constant support and encouragement throughout this research project. I would like to thank them for providing me this opportunity and for their consistent advice, inspiration, contribution and financial support throughout my study.

The generous support and assistance from the Canadian Wood Council is sincerely appreciated. Also, I would like to thank my colleagues Mr. Amid Elsabbagh and Mr. Milad Mohammadi for their contribution and assistance to this research effort.

This thesis is dedicated to my wife and family whose lifelong unconditional love and support has given me the strength to achieve all the success I have in my life.

# Table of Contents

---

<b>Abstract</b> .....	ii
<b>Acknowledgements</b> .....	iii
<b>List of Figures</b> .....	vii
<b>List of Tables</b> .....	xi
<b>Nomenclature</b> .....	xii
<b>Acronyms</b> .....	xiv
<b>Chapter 1 Introduction</b> .....	1
1.1 General.....	1
1.2 Introduction to Wood Frame Construction.....	3
1.2.1 Heavy Timber .....	3
1.2.1.1 Traditional Timber Frame Construction.....	4
1.2.1.2 Modern Post and Beam Construction .....	5
1.2.1.3 Cross Laminated Timber (CLT) .....	6
1.2.2 Light Frame .....	6
1.2.3 Canadian Code and Standard for Wood-Framed Buildings .....	8
1.2.4 Structural Components .....	9
1.2.4.1 Horizontal Diaphragms.....	10
1.2.4.2 Shearwalls.....	11
1.2.4.2.1 Types of Shearwall.....	12
1.3 Research Objective and Scope.....	14
1.4 Thesis Structure .....	14
<b>Chapter 2 Literature Review</b> .....	15
2.1 Earthquake Hazard in Canada .....	15
2.2 Seismic Risk Assessment .....	16
2.2.1 Existing Methodologies for Seismic Risk Assessment.....	17
2.2.1.1 Historical Background.....	17
2.2.1.2 United States.....	17

2.2.1.3 Developing Countries .....	19
2.2.1.4 Japan .....	20
2.2.1.5 New Zealand.....	20
2.2.1.6 Canada .....	21
2.3 Uncertainty in Seismic Risk Assessment and Fuzzy Logic as Solution.....	22
2.3.1 Fuzzy Sets and Membership Functions .....	22
2.3.2 If-Then Rules.....	24
2.3.3 Fuzzy Inference System (FIS) .....	26
2.4 Seismic Vulnerability of Wood Frame Construction .....	29
2.4.1 Performance of Wood Frame Construction in Previous Earthquakes .....	30
2.4.2 Seismic Deficiencies of Wood Frame Construction.....	33
2.4.3 Irregularity in Wood Frame Construction .....	37
2.4.4 Construction Quality of Wood Frame Construction.....	38
2.5.5 Evolution of Wood Frame Construction in US and Canada.....	41
2.5.5.1 United States.....	41
2.5.5.2 Canada .....	42

### **Chapter 3 Seismic Risk Assessment of Wood Frame Construction using Hierarchal**

<b>Fuzzy Rule Base Modeling .....</b>	<b>45</b>
3.1 General.....	45
3.2 Development of Hierarchical Structure for Seismic Risk Analysis of Buildings.....	45
3.3 Site Seismic Hazard Module ( $I^{SSH}$ ).....	48
3.3.1 Site Seismicity .....	49
3.3.2 Site Condition.....	50
3.3.3 Fundamental Period of Vibration .....	50
3.4 Building Vulnerability Module ( $I^{BV}$ ).....	51
3.4.1 Structural Vulnerability (SV).....	51
3.4.1.1 Increase in Demand (ID) .....	52
3.4.1.1.1 Vertical Irregularity (VI) .....	52
3.4.1.1.2 Plan Irregularity (PI).....	53
3.4.1.2 Decrease in Resistance (DR) .....	54
3.4.1.2.1 Construction Quality (CQ) .....	54
3.4.1.2.2 Year of Construction (YOC) .....	54

3.4.1.2.2.1 Seismic Force Factor (SFF) .....	55
3.4.1.2.2.2 Design and Detailing Factor (DDF).....	57
3.4.2 Non-Structural Vulnerability .....	60
3.4.2.1 Falling Hazards to Life (FHL).....	60
3.4.2.2 Hazards to Vital Operations.....	61
3.4.2.3 Increase in Non-Structural Hazard .....	62
3.4.3 Building Structural System.....	62
3.5 Building Importance/Exposure Module ( $I^E$ ) .....	66
3.6 Building Damageability Index ( $I^{BD}$ ) .....	67
3.7 Risk Index ( $I^R$ ) .....	68
3.8 Fuzzification Summary.....	69
<b>Chapter 4 Sensitivity Analysis .....</b>	<b>74</b>
4.1 General.....	74
4.2 Sensitivity Analysis of the Individual Input Parameters.....	74
4.3 Sensitivity Analysis of the Structural Building Damageability Index.....	81
<b>Chapter 5 CanRisk Seismic Risk Assessment of Wood Framed Buildings A Case Study for the City of Ottawa .....</b>	<b>91</b>
5.1 General.....	91
5.2 Urban RAT Wood Framed Building Inventory .....	91
5.3 Case Study .....	97
<b>Chapter 6 Summary, Conclusion and Future Recommendations.....</b>	<b>104</b>
6.1 Summary.....	104
6.2 Conclusion .....	105
6.3 Future Recommendations .....	105
<b>References .....</b>	<b>107</b>
<b>Appendix A .....</b>	<b>115</b>

## List of Figures

---

Figure 1-1: A light wood frame building in Santa Cruz Mountains, California, collapsed in the 1989 magnitude 6.9 Loma Prieta earthquake .....	2
Figure 1-2: Typical Mortise and Tenon Joinery used for Knee Bracing .....	4
Figure 1-3: Traditional Timber Frame Construction .....	5
Figure 1-4: Post and Beam Construction Using Diagonal Bracing .....	5
Figure 1-5: Cross Laminated Timber .....	6
Figure 1-6: Cross Laminated Timber Building.....	6
Figure 1-7: Typical Balloon Frame Construction.....	7
Figure 1-8: Components of a Typical Platform Frame Construction .....	8
Figure 1-9: Lateral Load Path in a Light Wood Frame Construction.....	10
Figure 1-10: Typical Blocked Horizontal Diaphragm.....	11
Figure 1-11: Wall Action to Resist Lateral Loads.....	12
Figure 1-12: Typical Prescriptive Bracing wall and Engineered Shearwall.....	13
Figure 2-1: The Earthquake Distribution in Canada.....	15
Figure 2-2: Membership Functions and Fuzzy Sets of the Input Variable, Vertical Irregularity .....	24
Figure 2-3: Graphical Illustration of the Example Fuzzy Inference System .....	28
Figure 2-4: Center of Area Calculated in the Defuzzification Phase of the Example FIS .....	29
Figure 2-5: Failure of Cripple Wall in Loma Prieta Earthquake .....	34
Figure 2-6: Chimney Damage in Northridge Earthquake.....	35
Figure 2-7: Failure in a Typical Wood Frame Construction Caused by Soft Story, in Loma Prieta Earthquake (Left) and Northridge Earthquake (right) .....	36
Figure 2-8: Nails Missing the Truss .....	39
Figure 2-9: The Sheathing Panel on the Interior Shearwall not extended to the Roof Diaphragm .....	40
Figure 2-10: Evolution of Wood Frame Construction in United States under UBC .....	41
Figure 2-11: The Impact of the New Categorization, Proposed in Part 9 of NBCC 2010, across Canada, Due to Earthquake .....	44
Figure 3-1: Hierarchical Structural Seismic Risk Analysis of Buildings .....	46
Figure 3-2: Hierarchical Non-structural Seismic Risk Analysis of Buildings.....	47
Figure 3-3: The Fuzzy System used for Site Seismic Hazard Fuzzification .....	48
Figure 3-4: Uniform Hazard Spectra based on NBCC-2010.....	49
Figure 3-5: Historical Development of Base Shear Equation of the NBCC.....	56

Figure 3-6: Failure of office partitions, ceilings, and light fixtures in the 1994 Northridge Earthquake .....	61
Figure 3-7: Membership Functions and Fuzzy Sets of the Variables with TFN Values of.....	69
Figure 3-8: Membership Functions and Fuzzy Sets of the Variables with TFN Values of.....	70
Figure 3-9: Membership Functions and Fuzzy Sets of the Variables with TFN Values of.....	70
Figure 3-10: Membership Functions and Fuzzy Sets of the YOC Variable with TPFN Values of.....	70
Figure 4-1: Increase in Demand of a Building .....	75
Figure 4-2: Structural Vulnerability of a Building built prior to 1940 with poor construction quality	76
Figure 4-3: Structural Vulnerability of a Building built in 2010 with good construction quality .....	76
Figure 4-4: Building Vulnerability of a Wood Light Frame Building built prior to 1940 with poor construction quality .....	77
Figure 4-5: Building Vulnerability of a Wood Light Frame Building built in 2010 with good construction quality .....	78
Figure 4-6: Non-structural deficiency of a Building .....	79
Figure 4-7: Non-Structural Vulnerability of a Building built prior to 1970 with very high ID.....	80
Figure 4-8: Non-Structural Vulnerability of a Building built in 2010 with very low ID .....	80
Figure 4-9: Upper and Lower Bound Limits of Building Damageability for Post and Beam Structures resting on various soil conditions in Ottawa, Ontario .....	84
Figure 4-10: Upper and Lower Bound Limits of Traditional Timber Frame Structures resting on various soil conditions in Ottawa, Ontario .....	84
Figure 4-11: Upper and Lower Bound Limits of Building Damageability for Engineered Light Wood Frame Structures sheathed with WSP resting on various soil conditions in Ottawa, Ontario.....	85
Figure 4-12: Upper and Lower Bound Limits of Building Damageability for Engineered Light Wood Frame Structures sheathed with WBW resting on various soil conditions in Ottawa, Ontario.....	85
Figure 4-13: Upper and Lower Bound Limits of Building Damageability for Engineered Light Wood Frame Structures sheathed only with Gypsum Wallboard or Stucco resting on various soil conditions in Ottawa, Ontario .....	86
Figure 4-14: Upper and Lower Bound Limits of Building Damageability for Non-Engineered Light Wood Frame Structures sheathed with Horizontal Lumber or Shiplaps resting on various soil conditions in Ottawa, Ontario.....	86
Figure 4-15: Comparison of Upper and Lower Bound Limits of Building Damageability for Engineered Light Frame structures sheathed with WSP, Resting on Reference Site Soil Class C .....	86
Figure 4-16: Comparison of Upper and Lower Bound Limits of Building Damageability for Engineered Light Frame structures sheathed with WBW Resting on Reference Site Soil Class C ....	86

Figure 4-17: Comparison of Upper and Lower Bound Limits of Building Damageability for Engineered Light Frame structures sheathed Only with Gypsum Wallboard or Stucco Resting on Reference Site Soil Class C .....	87
Figure 4-18: Comparison of Upper and Lower Bound Limits of Building Damageability for Non-Engineered Light Frame structures sheathed with Horizontal Lumber or Shiplaps Resting on Reference Site Soil Class C .....	87
Figure 4-19: Comparison of Building Type for Structural Building Damageability of Structures Resting on Reference Site Soil Class C in Edmonton, AB.....	88
Figure 4-20: Comparison of Building Type for Structural Building Damageability of Structures Resting on Reference Site Soil Class C in Ottawa, ON.....	88
Figure 4-21: Comparison of Building Type for Structural Building Damageability of Structures Resting on Reference Site Soil Class C in Victoria, BC .....	89
Figure 5-1: Study Area .....	92
Figure 5-2: Spatial Distribution of Construction Type of Wood Framed Buildings in Ottawa, Ontario .....	93
Figure 5-3: Spatial Distribution of the Wood Framed Buildings' Number of Stories in Ottawa, Ontario.....	94
Figure 5-4: Spatial Distribution of Soil Classification of Buildings in Ottawa, Ontario.....	95
Figure 5-5: Spatial Distribution of Year of Construction of Buildings in Ottawa, Ontario .....	96
Figure 5-6: Spatial Distribution of Year of Construction of Wood Framed Buildings in Ottawa, Ontario .....	97
Figure 1-A: Upper and lower bound limits of $I^{BD}$ for Post and Beam structures with shearwall resting on various soil conditions in Edmonton, Alberta .....	115
Figure A-2: Upper and lower bound limits of $I^{BD}$ for Traditional Timber Frame structures resting on various soil conditions in Edmonton, Alberta .....	115
Figure 3-A: Upper and lower bound limits of $I^{BD}$ for Engineered Wood Light Frame structures sheathed with WSP resting on various soil conditions in Edmonton, Alberta .....	116
Figure A-4: Upper and lower bound limits of $I^{BD}$ Engineered Wood Light Frame structures sheathed with WBW resting on various soil conditions in Edmonton, Alberta .....	116
Figure A-5: Upper and lower bound limits of $I^{BD}$ for Engineered Wood Light Frame structures sheathed only With Gypsum Wallboard or Stucco resting on various soil conditions in Edmonton, Alberta.....	117

Figure A-6: Upper and lower bound limits of  $I^{BD}$  for Non- Engineered Wood Light Frame structures sheathed with Horizontal Lumber or Shiplaps resting on various soil conditions in Edmonton, Alberta ..... 117

Figure A-7: Upper and Lower Bound Limits of Building Damageability for Post and Beam Structures resting on various soil conditions in Victoria, British Columbia..... 118

Figure A-8: Upper and Lower Bound Limits of Building Damageability for Traditional Timber Frame Structures resting on various soil conditions in Victoria, British Columbia ..... 118

Figure A-9: Upper and Lower Bound Limits of Building Damageability for Engineered Light Frame Structures sheathed with WSP resting on various soil conditions in Victoria, British Columbia ..... 119

Figure A-10: Upper and Lower Bound Limits of Building Damageability for Engineered Light Frame Structures sheathed with WBW resting on various soil conditions in Victoria, British Columbia ... 119

Figure A-11: Upper and Lower Bound Limits of Building Damageability for Engineered Light Frame Structures sheathed with Gypsum Wallboard or Stucco resting on various soil conditions in Victoria, British Columbia..... 120

Figure A-12: Upper and Lower Bound Limits of Building Damageability for Non-Engineered Light Frame Structures sheathed with Horizontal Lumber or Shiplaps resting on various soil conditions in Victoria, British Columbia..... 120

## List of Tables

---

Table 2-1: The fuzzy rule base system developed for evaluating the increase in seismic demand (ID) of a building.....	26
Table 2-2: The Aggregation Process of the Example Rules.....	28
Table 2-3: Documented Seismic Performance of Wood Frame Construction in Previous Earthquakes .....	31
Table 2-4: Overview of casualties in the previous major earthquakes .....	33
Table 2-5: New Limitations on the Application of Part 9 of NBCC .....	44
Table 3-1: NBCC-2010 Seismic Data for Toronto, Ottawa, Vancouver.....	49
Table 3-2: NBCC-2010 Site Classification .....	50
Table 3-3: Empirical Formulas for Building Period defined in NBCC-2010.....	51
Table 3-4: Linguistic Input Parameters and Transformation Values for VI.....	53
Table 3-5: Linguistic Input Parameters and Transformation Values for PI.....	53
Table 3-6: Linguistic Input Parameters and Transformation Values for CQ.....	54
Table 3-7: Cut-off values for the ratio of NBCC-2005 base shear to previous year base shear equations.....	57
Table 3-8: Transformation Values and Breaking Years for the Computation of the DDF for Engineered Wood Framed Buildings.....	58
Table 3-9: Transformation Values and Breaking Years for the Computation of the DDF for Non-Engineered Wood Framed Buildings.....	59
Table 3-10: Linguistic Input Parameters and Transformation Values for FHL.....	61
Table 3-11: Linguistic Input Parameters and Transformation Values for HVO .....	62
Table 3-12: Types of Sheathing and their Expected Seismic Behaviour.....	63
Table 3-13: Transformation Values for different types of Wood Frame Construction .....	65
Table 3-14: Building Importance Categories as defined in NBCC-2010 .....	66
Table 3-15: Linguistic Input Parameters and Transformation Values for Economic Impact.....	67
Table 3-16: Comparison of Building Damage States of ATC-13 and CanRisk.....	68
Table 3-17: CanRisk Risk Level and Risk Index Range .....	69
Table 3-18: Summary of Fuzzification of Hierarchical Structures.....	71
Table 5-1: Photos of the Light Wood Frame Buildings under Investigation.....	97
Table 5-2: Summary of Input parameters (performance modifiers) for buildings under investigation .....	101
Table 5-3: Summary of Results of Buildings under Investigation .....	103

# Nomenclature

---

$\mu_x$	Degree of membership
$A_i$	Area of a membership function (i)
$A_{i1}, A_{i2}$	Input membership fuzzy sets for $i^{\text{th}}$ rule
$B$	Output membership fuzzy set
$C1$	Concrete moment frame buildings
$C2$	Concrete shear wall buildings
$C3$	Concrete frames with infill masonry shear walls
$I^{\text{BD}}$	Building Damageability Index
$I_{\text{NS}}^{\text{BD}}$	Non-structural building damageability index
$I_{\text{S}}^{\text{BD}}$	Structural building damageability index
$I^{\text{BV}}$	Building Vulnerability Index
$I_{\text{NS}}^{\text{BV}}$	Non-structural building vulnerability index
$I_{\text{S}}^{\text{BV}}$	Structural building vulnerability index
$I^{\text{E}}$	Building Importance/Exposure Index
$I^{\text{R}}$	Risk Index
$I_{\text{NS}}^{\text{R}}$	Non-structural risk index
$I_{\text{S}}^{\text{R}}$	Structural risk index
$I_{\text{ALL}}^{\text{R}}$	Overall building risk index
$I^{\text{SSH}}$	Site Seismic Hazard Index
$M_{\text{V}}$	Higher mode factor
$N$	Total number of rules in a FRB
$R_{\text{d}}$	Ductility-related force modification factor, as specified in the National Building Code of Canada
$R_i$	Represents the $i^{\text{th}}$ rule of a FRB
$R_{\text{o}}$	Overstrength-related force modification factor, as specified in the National Building Code of Canada
$S_{\text{a}}$	Spectral acceleration
$S_{\text{a}}(T1)$	Spectral acceleration of a building with a period of T1
$T1$	Fundamental period of vibration of a building

URM	Unreinforced masonry buildings
$V_s$	Shear wave velocity
W1	Light wood frame residential and commercial buildings equal to or smaller than 5000 ft <sup>2</sup> (465 m <sup>2</sup> )
W2	Light wood frame buildings greater than 5000 ft <sup>2</sup> (465 m <sup>2</sup> )
$X_1, X_2$	Input variables (antecedents)
Y	Output crisp variable (consequent)

# Acronyms

---

AP	Apartment
ASCE	American Society of Civil Engineering
ATC	Applied Technology Council
AVG	Average
BD	Building damageability
BI/E	Building importance/exposure
BIF	Building importance factor
BU	Building use
BV	Building vulnerability
BSS	Building structural system
CC	Catastrophic consequences
CLT	Cross Laminated Timber
CMHC	Canada Mortgage and Housing Corporation
COL	At/Near collapse
CRIT	Critical
CSA	Canadian Standard Association
CQ	Construction quality
CUREE	Consortium of Universities for Research in Earthquake Engineering
CWC	Canadian Wood Council
D	Dwelling
DDF	Design and detailing factor
DR	Decrease in resistance
DL	Diagonal Lumber
DNA	Details not available
EERI	Earthquake Engineering Research Institute
EI	Economic impact
ENG	Engineered
EPB	Earthquake prone buildings

FEMA	Federal Emergency Management Agency
FHL	Falling hazards to life
FIS	Fuzzy inference system
FRB	Fuzzy rule base
GD	Good
GIS	Geographical information system
GWB	Gypsum Wallboard
H	High
HAZUS-MH	Hazards U.S. – Multi-Hazards
HV	Heavy
HVAC	Heating, ventilation, and air conditioning
HVO	Hazards to vital operations
HWP	High wind pressure
ID	Increase in demand
IDNDR	International Decade for Natural Disaster Reduction
IEP	Initial evaluation procedure
INSH	Increase in non-structural hazard
L	Low
LF	Light Frame
LT	Light
M	Moderate
MARG	Marginal
N/A	Not Available
NBCC	National Building Code of Canada
NEHRP	National Earthquake Hazards Reduction Program
NG	Negligible
NENG	Non-Engineered
NIBS	National Institute of Building Sciences
NRCC	National Research Council of Canada
NSBD	Non-structural building damageability

NSBV	Non-structural building vulnerability
NSD	Non-structural deficiency
NSR	Non-structural risk
NSV	Non-structural vulnerability
NZ	New Zealand
NZSEE	New Zealand Society for Earthquake Engineering
OBR	Overall building risk
OSB	Oriented Strand Board
PGA	Peak ground acceleration
PR	Poor
PI	Plan Irregularity
RC	Reinforced concrete
RVS	Rapid visual screening
SBD	Structural building damageability
SBV	Structural building vulnerability
SDOF	Single degree of freedom
SEAOC	Structural Engineers Association of California
SFF	Seismic force factor
SFRS	Seismic force-resisting system
SPI	Seismic priority index
SR	Structural risk
SSH	Site seismic hazard
SV	Structural vulnerability
TFN	Triangular fuzzy numbers
TPFN	Trapezoidal fuzzy numbers
UBC	Uniform Building Code
UHS	Uniform hazard spectrum
URBAN RAT	Urban Rapid Assessment Tool
URM	Unreinforced Masonry Buildings
VH	Very high

VI	Vertical irregularity
VL	Very low
WBW	Wood Based Wallboard
WSP	Wood Structural Panel
YOC	Year of construction

# Chapter 1

## Introduction

---

### 1.1 General

Wood is one of the oldest construction materials used by humans. It is readily available, very economical where wood is accessible, easily machinable, and most importantly, it is very strong relative to its weight, which is an advantage in a seismic event (Senft, 2003). These qualities have made wood frame construction the most widely used construction type for low-rise residential construction in North America. In the past few decades, this type of building has experienced a number of earthquakes all around the world, providing researchers and designers with an opportunity to assess its seismic performance (Rainer and Karacabeyli, 2000).

The historical seismic performance of wood frame construction has shown that in general, properly constructed wood-framed buildings are capable of resisting the damaging effects of earthquake ground motion especially with regard to life safety (Park and van de Lindt, 2010). However, societal and economic losses due to recent earthquakes in urban areas have been surprisingly high (Rojhan and Eghuchi, 2000) which can be attributed to many factors. From the structural point of view, although the seismic behaviour of light wood frame subsystems, such as walls and floors, have performed well individually, the primary deficiencies have been related to the interfaces between them; such as connections between floors and walls, roofs and walls, and walls and foundations. On the other hand, low rise buildings are typically non-engineered. Therefore, even if they are light weight and have many connectors (nails) which provide redundancy and ductility, the lack of engineering makes seismic reliability not consistent from one building to another. Also, what used to be considered as “typical light frame”, has changed substantially with time. In the 1960s, the size of the building was smaller, the structure was more regular and contained many walls (and less openings). Modern day structures are larger and have more openings and open spaces which may increase their damageability. Figure 1-1 shows a light wood frame building in California, collapsed in the 1989 magnitude 6.9 Loma Prieta Earthquake.



**Figure 1-1: A light wood frame building in Santa Cruz Mountains, California, collapsed in the 1989 magnitude 6.9 Loma Prieta Earthquake**  
(Photo from USGS)

In the United States, the seismic vulnerabilities of wood frame construction were largely observed in the 1989 Loma Prieta Earthquake and the 1994 Northridge Earthquake, where for the first time the engineering community focused the attention on the key weaknesses in wood frame construction. These observations caused significant changes in local building codes in order to reduce the damage observed in wood-framed buildings (Graf, 2008). Some of the factors that were identified to contribute to the observed damage were: 1) a large portion of buildings including wood frame construction, were constructed prior to the adoption and enforcement of seismic design provisions; 2) existing seismic design provisions were intended to provide life safety, not damage control; 3) since the code provisions were mainly based on the observation of building behaviour during actual earthquakes, lack of knowledge caused lack of adequate code regulations; and finally, 4) even if the buildings were properly designed, they were not constructed with good quality workmanship (Rojhan and Eghuchi, 2000).

In Canada, due to the similarities of the housing stock, it is reasonable to expect similar damage to wood frame construction during an earthquake as seen in the United States (Ventura and Kharrazi, 2003). The earthquake hazard is widespread across the country and about 40 percent of Canadians live in regions with high to moderate seismicity (Cassidy et al., 2010; Statistics Canada, 2011). Also, the main objective in the NBCC seismic design provisions is life safety with no serious considerations given to minimizing property damage (Ventura and Kharrazi, 2003). Considering all these factors, and recognizing the potential for large losses to

the existing building stock with inadequate earthquake resistance, there is a need for developing tools to conduct seismic risk assessment in order to identify critical wood-framed buildings and prioritize their retrofitting requirements (Rojhan and Eghuchi, 2000). Using the information provided by seismic risk assessment, decision makers are able to act affectively and reduce potential damage to populated urban communities.

In the proposed research, a risk-based visual seismic assessment model is presented, along with a module for screening tool (CanRisk) to identify seismically deficient buildings for more detailed evaluation. The tool uses fuzzy logic, a computing technique, to capture the inherent uncertainty of a building's seismic risk assessment.

In order to perform a thorough seismic assessment of wood structures, first, it is necessary to understand the different types of wood frame construction and their structural and non-structural elements that exist. The following section is an introduction to wood frame construction, followed by objectives and scope of the research conducted.

## **1.2 Introduction to Wood Frame Construction**

### **1.2.1 Heavy Timber**

Until the mid-1800s, most building construction was built using timber with wood to wood connections. Trees were plentiful, craftsmanship was available, and metal connectors, such as nails and bolts, were rare and expensive. In present days this type of construction method is mostly used in high end residential constructions, restaurants, lodges, and other areas requiring a rustic aesthetic (*Heavy Timber Frame Construction*, n.d.). Heavy timber structures can be divided into two main types, namely traditional timber frame construction and the modern-day equivalent in the form of post and beam timber construction. Recently, a new type of structural system called Cross Laminated Timber (CLT) has emerged in Canada. Such construction type would also fall under heavy timber construction using what is described as “mass wood”, which primarily rely on CLT slabs combined with either CLT shearwalls or post and beam systems.

### 1.2.1.1 Traditional Timber Frame Construction

Traditional timber frame construction is characterized by traditional wooden joineries such as Mortise and Tenon joined with wood pegs or wedges. The joints rely mostly on using the wood in compression and they are detailed in a way that failure modes, such as tension perpendicular to grain and shear, are avoided. Typical basic joineries include: Mortise and Tenon, Dovetail, Tongue and Fork, and Shoulder Joint. The other seismically important elements in a traditional timber frame are knee braces. Their primary function is to provide rigidity and stiffening of the connection where major beams and columns join together providing racking resistance to the frame. An example of a Mortise and Tenon joint connecting the knee braces to the post and beam is shown in the Figure 1-2 (Erikson and Schmidt, 2003).

Well-designed timber frame may not need to rely on shear walls or infill framing to achieve lateral stability. However, it is generally recommended that structural loads on timber frames be limited to gravity loads and that lateral loads be carried by other lateral load bracing systems, such as conventional shear walls (Hendricks, 2009). Figure 1.3 represents a house built using traditional timber frame construction. This presents an example where little to no lateral bracing elements, beyond the knee bracings, is utilized.

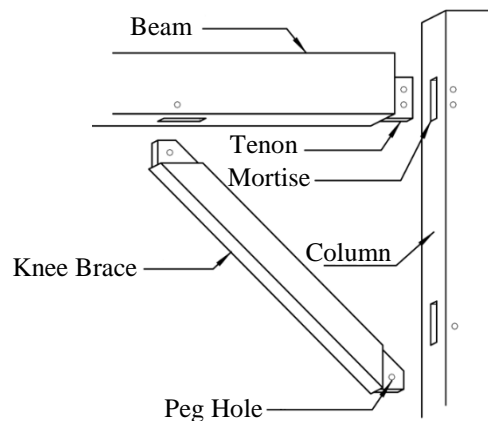

**Figure 1-2: Typical Mortise and Tenon Joinery used for Knee Bracing**  
(Schmidt and Erikson, 2003)



**Figure 1-3: Traditional Timber Frame Construction**  
(Riverbend Timber Framing, 2014)

### **1.2.1.2 Modern Post and Beam Construction**

Post and beam construction typically uses mechanical fasteners, such as steel plate connectors, to join the structural members together, as seen in Figure 1.4. This type of construction usually uses diagonal members to provide adequate lateral bracing, while maintaining open space. Due to their effectiveness in resisting lateral loads, light frame wood shearwalls have been used in conjunction with post and beam construction. In many cases the steel is jack-knifed in the timber members to provide an appearance of traditional joinery (Hendricks, 2009).

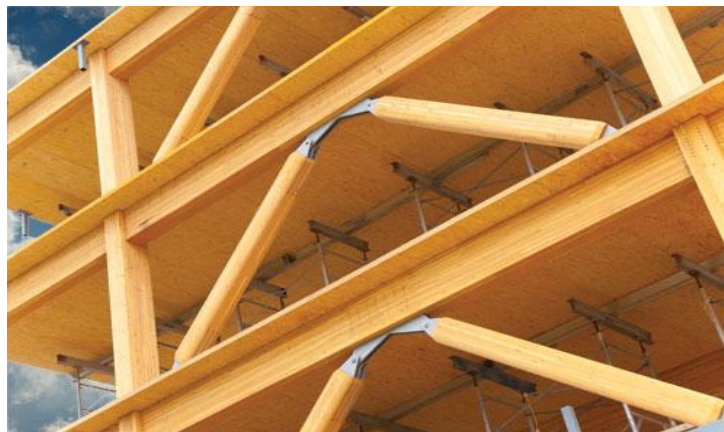

**Figure 1-4: Post and Beam Construction Using Diagonal Bracing**  
(Photo by K. K. Law, 2012)

### 1.2.1.3 Cross Laminated Timber (CLT)

Cross Laminated Timber (CLT) is a multi-layer engineered wood product produced by gluing three to seven dimensional lumbers, oriented at right angle to each other, to increase the rigidity and stability of the plate (Figure 1-5). The exceptional structural properties of this structural panel make it well suited to floors, walls, and roofs. CLT will likely be constructed as slabs with post and beam (most likely of glulam) or as a structure constructed entirely with CLT, where CLT shearwalls are used, as seen in Figure 1-6. Since it is prefabricated and most of the work is done in the factory, its installation is more precise and less influenced by workmanship errors. The mechanical connections used in this type of construction provide ductility, enabling it to have a very good seismic performance (FPInnovations, 2010).

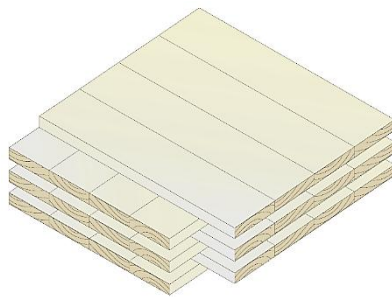

**Figure 1-5: Cross Laminated Timber**  
(*Cross Laminated Timber in BC*, 2012)

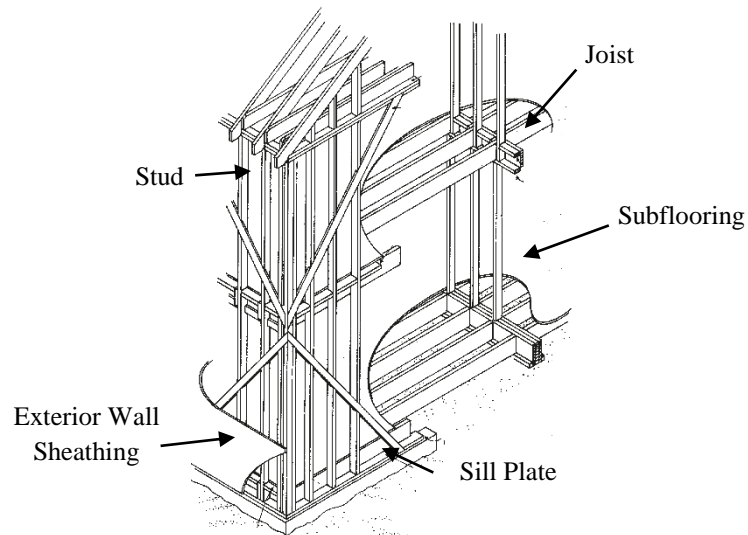

**Figure 1-6: Cross Laminated Timber Building**  
(KLH GmbH, 2010)

### 1.2.2 Light Frame

In the late 1800s, balloon frame construction was introduced as a new method of wood frame construction and as an alternative for the early heavy timber construction (CMHC, 1999). The mass production of nails and availability of lumbers at that time made this system

possible. In this method, the studs used for exterior and some interior walls pass through the floors and end at the roof level (Figure 1-7). It considerably sped up the construction process. However, since the connections between floor joist and studs are not prefabricated and not easy to be assembled on site, and are relatively costly, this type of framing is rarely used in the current construction practice (Ventura and Kharrazi, 2003; CMHC, 1999).

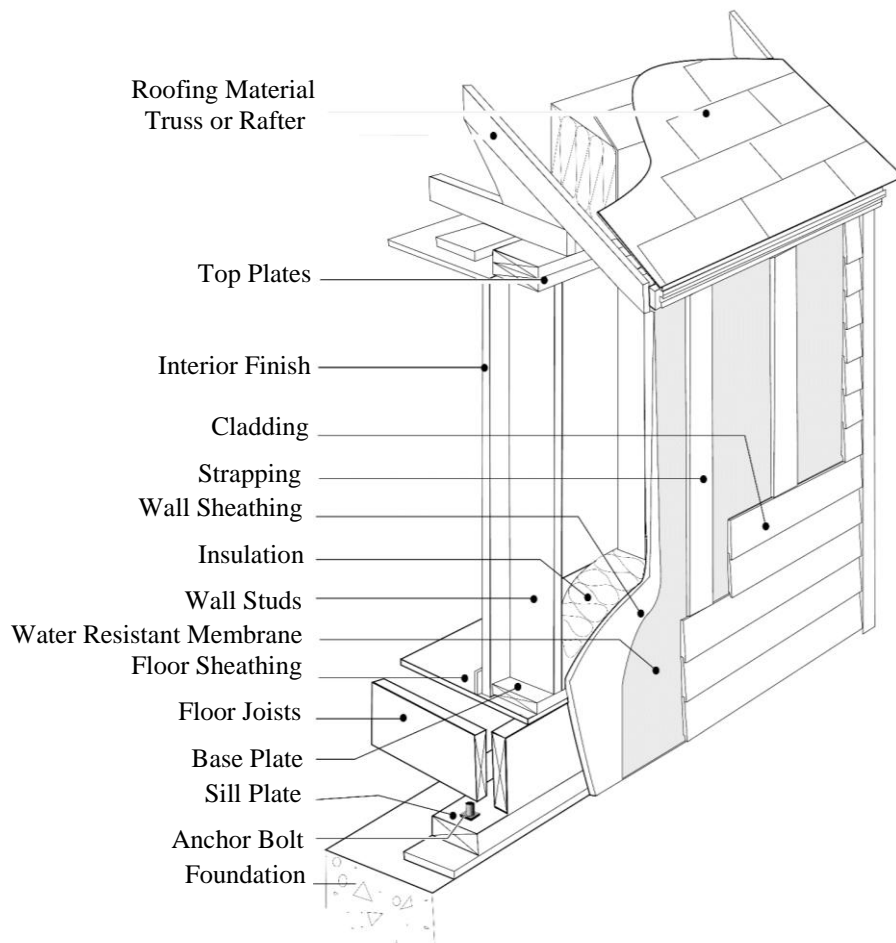

**Figure 1-7: Typical Balloon Frame Construction**  
(AWC, 2001)

The problems associated with balloon frame construction was the driving force for the development of a new method for light frame construction called platform construction. In this method, each floor of the building is built separately from the floors below and above, using pre-cut standard size materials. In platform construction, the floor system provides a platform or working area for assembling and erecting the walls and partitions, since each floor is assembled independently (Ventura and Kharrazi, 2003). Heavy lifting equipment is not needed in this system, since the studs are only one story high and they can be easily assembled on each floor and erected one story at a time.

Typical modern platform wood frame structures consist of a concrete or masonry block foundations whereupon there are joists covered with wood structural panels (Oriented Strand Board (OSB) or plywood), creating a platform connected to the foundation with anchor bolts. Walls consist of a horizontal sill plate and repetitive one story high studs which are typically spaced 400 mm. On the exterior side, the studs are nailed to the plywood or OSB, but on the

interior, gypsum wall boards (GWB) are typically used. Prefabricated trusses are used in the roof, attached to the top plate of the walls and covered with wood structural panels, OSB or plywood (Rainer and Karacabeyli, 2000). Figure 1-8 represents the main components of a platform wood frame construction. The primary material used in this type of construction is softwood. Because of the light weight and machinability of this type of wood, it is much better handled and worked than hardwood and it is more common in platform construction (CMHC, 1999).



**Figure 1-8: Components of a Typical Platform Frame Construction**  
(CMHC, 2002)

### 1.2.3 Canadian Code and Standard for Wood-Framed Buildings

Timber structures are designed and detailed based on the provisions of the National Building Code of Canada (NBCC) and the Engineering Design in Wood standard (CSA O86). These provisions either follow full engineering design (i.e. following Part 4 of the NBCC and

the CSA O86 provisions) or are based on historic performance of specific types of wood buildings (i.e. following the prescriptive requirements of Part 9 of the NBCC).

Seismic design provisions in Part 4 of the NBCC require explicit design for the seismic force-resisting systems (SFRS). However, since 1965, for wood buildings (including most dwellings) of up to three stories in height, it is permissible to detail and construct using the prescriptive rules of Part 9 of NBCC. Part 9 covers the design of residential, business, personal service, mercantile and some industrial wood framed buildings, three stories or less in building height, 600 m<sup>2</sup> or less in building area, meeting the following limitations outlined in NBCC 2010 (NRCC, 2010):

- Wall, roof and floor planes are comprised of repetitive wood structural members spaced no more than 600 mm o.c.,
- Walls, roofs and floors are clad, sheathed or braced on at least one side,
- Clear spans of wood members are limited to 12.2 m, and
- The floor live load does not exceed 2.4 kPa.

The requirements of Part 9 of NBCC are a combination of calculated designs and solutions based on historic performance. They can be used without the supervision of an engineer or an architect (CWC, 2009).

#### **1.2.4 Structural Components**

Walls, and floors or roof diaphragms are the main seismic resistant components of a light wood frame construction. These elements and their connectors provide the required load path for lateral loads to be transferred to the foundation and supporting soils, as seen in Figure 1-9 (NIBS, 2006). For this to happen, all structural members should be interconnected properly, since it is the action of the nails and other connectors, used to attach the structural sheathing to the structural members or structural members to each other, that provides the earthquake resistance in a light wood frame construction. The connectors used in the horizontal diaphragm boundary edges, where the loads are transferred to the walls, are critical for this load transfer (ATC/SEAOC, n.d; NIBS, 2006). The structure must also resist the horizontal sliding forces and the overturning moments produced by lateral loads. In the case of overturning moments, which create uplift at the end of the wall, the uplift is resisted by special brackets or straps

called hold-downs. Also, to resist the horizontal sliding loads, anchorages are provided at the bottom of the wall (Graf, 2008).

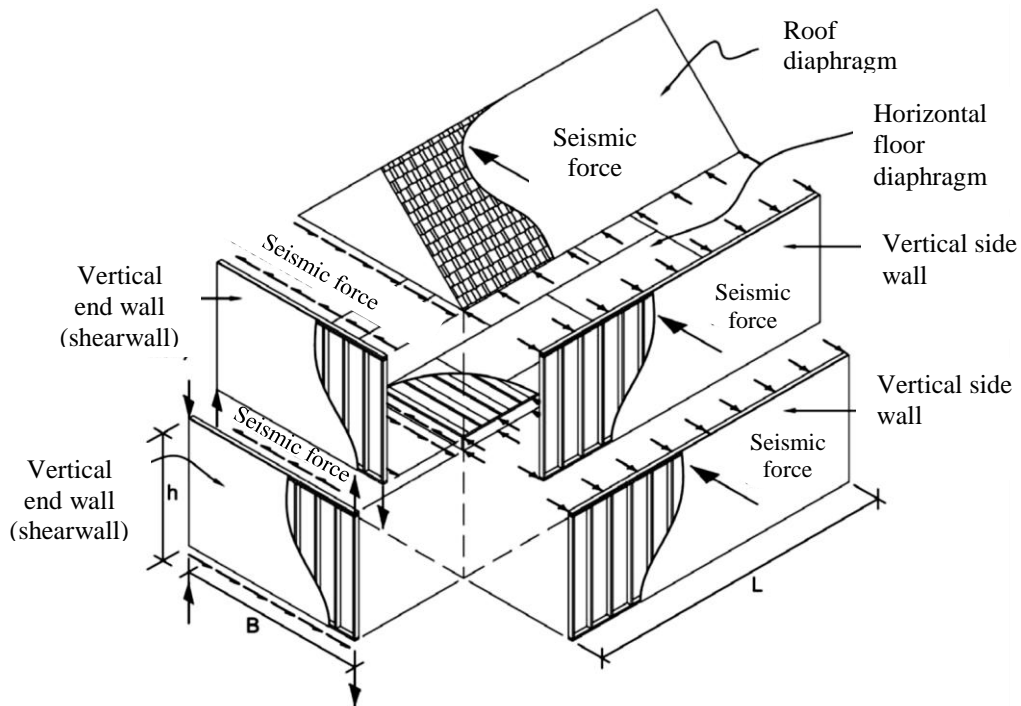

**Figure 1-9: Lateral Load Path in a Light Wood Frame Construction**  
(NIBS, 2006)

#### 1.2.4.1 Horizontal Diaphragms

Horizontal diaphragm (floor or roof system) is the first structural element of a light wood frame construction, resisting lateral loads. It consists of joists and blockings, as framing, sheathed with wood structural panels (OSB or plywood). The capacity of the diaphragm depends on its sheathing grade and thickness, nail type and size, framing member size and species, geometric layout of the sheathing (stagger), direction of load relative to the stagger, and whether or not there is blocking behind every joint to ensure shear continuity across panel edges (NIBS, 2006). Figure 1-10 shows a typical floor system in the light wood frame construction.

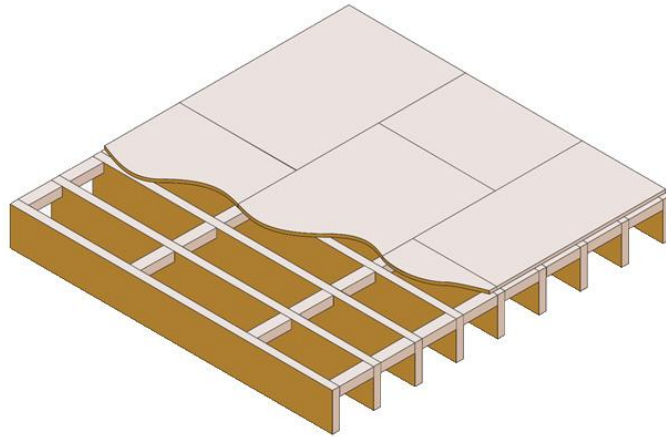

**Figure 1-10: Typical Blocked Horizontal Diaphragm**  
(APA, 2003)

#### **1.2.4.2 Shearwalls**

The other main lateral load resisting element in light wood frame structures is shearwall which consists of double top plates, studs, and sole or sill plates, sheathed with wood structural panels on one or both sides. The thickness of the sheathing, the size and spacing of the fasteners, the sheathing layout pattern and the use of wood blocking affect the shear capacity of a shearwall (ATC/SEAOC, n.d.). The ductility and the energy dissipation of a shearwall are provided by the nail joint between the sheathing panels and the framing.

These vertical diaphragms resist sliding, overturning, and racking loads developed in a structure by an earthquake (NIBS, 2006). If the shearwall is on top of a foundation, the sill plate is bolted to the foundation. To resist the overturning loads in a shearwall, different devices such as straps, bolts, nails, or hold-down brackets are used at the bottom of the shear walls, attached to the wall framing of the story below or to the sill plate of the ground floor shearwall. Figure 1-11 illustrate the wall action to resist the lateral loads.

The double top plates on the shearwall are also essential for the seismic resistance of the structure. These plates act as both chords and collectors in a diaphragm, depending on the axis of the load applied. A chord resists tension and compression forces developed in a horizontal diaphragm and a collector transmits diaphragm forces into shear walls or frames (ATC/SEAOC, n.d.; NIBS, 2006).

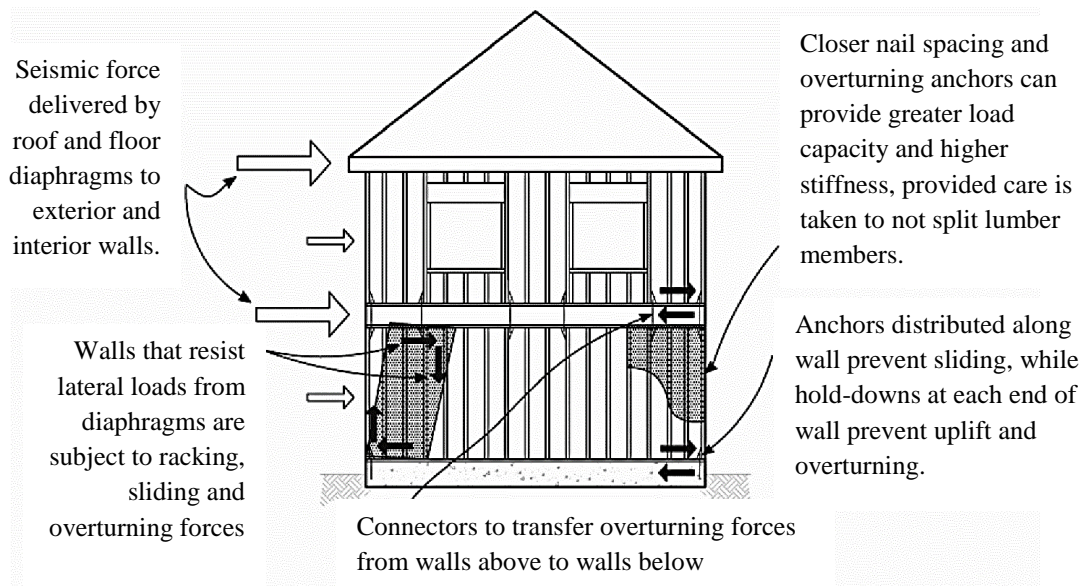

**Figure 1-11: Wall Action to Resist Lateral Loads**  
(NIBS, 2006)

#### 1.2.4.2.1 Types of Shearwall

There are two types of wall bracing systems recognized by Part 9 of the NBCC and the timber design standard (CSA O86) depending on whether the wall is engineered or based on conventional construction.

The bracing systems that are recognized in a prescriptive braced wall are: continuous let-in bracing, lumber sheathing, wood structural panels (OSB or plywood), structural fiberboard, gypsum wallboard, particleboard sheathing, portland cement plaster (stucco), and hardboard panel siding. Of the acceptable braced wall panel products, wood structural panels and diagonal lumber sheathing are known to perform better than others in a seismic event (NIBS, 2006). Let-in bracing is not allowed to be used in regions of high earthquake hazard, since it often fails when the wall racks during an earthquake (NIBS, 2006; NRCC, 2010). In the 2010 edition of NBCC, new requirements are outlined for prescriptive braced walls based on the seismicity of construction site. Prior to NBCC 2010, there was no seismic requirement considered for light wood frame buildings. In this edition, braced walls built in regions with moderate and low seismicity can use the same system outlined in the previous code, but the ones in regions of high seismicity are limited to the new seismic requirements. Examples of these new requirements include; the exterior walls must be constructed using plywood,

oriented strand board (OSB), or diagonal lumber as sheathing, or the minimum length of individual braced wall panels should be 750 mm (NRCC, 2010).

In the engineered shearwalls, studs, sheathing panels, anchor bolts and the hold-downs are specifically designed according to the calculated earthquake force. Therefore, the length of shearwall sections, the thickness of sheathing, nail size and spacing, number of base shear anchor bolts and the size of hold-downs are determined by an engineer based on the timber design standard (CSA O86) (CWC, 2002).

Overall, the lack of detailing in prescriptive braced walls limits their strength and stiffness when compared to engineered shearwalls (NIBS, 2006). Figure 1-12 illustrates a typical prescriptive and engineered shearwall.

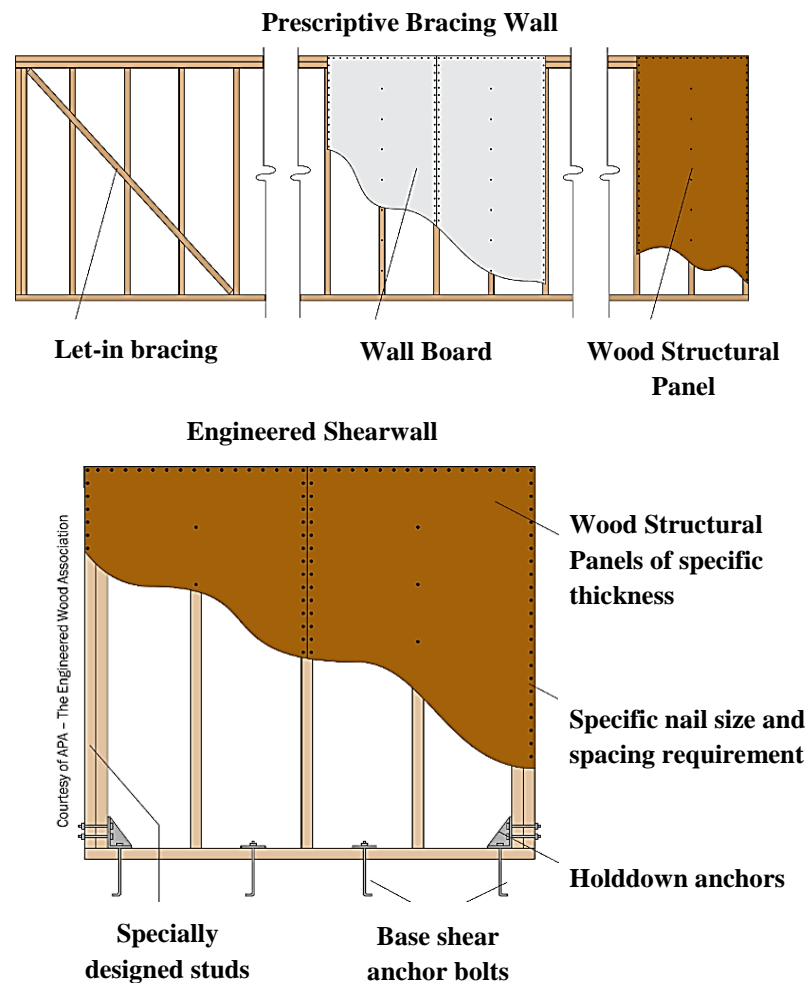

**Figure 1-12: Typical Prescriptive Bracing wall and Engineered Shearwall**  
(APA, 1997, Cited by CWC, 2002.)

### **1.3 Research Objective and Scope**

CanRisk is a risk based seismic assessment tool originally developed by Dr. Tesfamariam (2008) for reinforced concrete. The software was further developed by Mr. Elsabbagh (2013) by refining the original fuzzy methodology and adding new features for unreinforced masonry (URM) buildings. The objective of this thesis is to enhance the existing CanRisk program, expand the evaluation, and include the assessment of wood structures. This was achieved by exploring all the essential factors in wood frame construction in Canada that affects its seismic performance, along with its structural and non-structural seismic deficiencies observed during previous earthquakes. Also, the applicability of the proposed seismic assessment model and the CanRisk tool is demonstrated by performing seismic risk assessment on a number of wood-framed buildings in the city of Ottawa.

### **1.4 Thesis Structure**

The thesis consists of six chapters:

Chapter 1 introduces various wood frame constructions and presents the research goals;

Chapter 2 provides a literature review, including a review of earthquake hazard in Canada, seismic risk, seismic risk assessment methodologies, fuzzy logic theory, and a literature review on the seismic vulnerability of wood frame construction.

Chapter 3 presents the CanRisk software, with the hierarchical fuzzy rule-based model for the seismic risk assessment

Chapter 4 presents a sensitivity analysis to verify the proposed seismic risk assessment model

Chapter 5 presents a case study of the seismic risk assessment of a number of wood-framed buildings in the city of Ottawa using CanRisk, along with a summary of the building data collected for the seismic risk assessment of the existing wood-framed buildings in Ottawa.

Chapter 6 summarizes the work carried out in the current study and provides some recommendations for future research efforts.

# Chapter 2

## Literature Review

### 2.1 Earthquake Hazard in Canada

Hazard is defined as the probability of occurrences of a potentially damaging phenomenon within a specified period of time and within a given area (Smith, 2001; Gulati, 2006). In Canada, the earthquake hazard covers a large area, as seen in Figure 2-1. Each year, an average of 50 earthquakes are felt in Canada, even though there are many earthquakes happening every day which are too small to be felt (Cassidy et al., 2010). It can also be seen from Figure 2-1 that the majority of the large and frequent earthquakes occur along the west coast near regions such as Vancouver Island, which has one of the highest levels of earthquake hazard in the country. This type of distribution of earthquake hazard in Canada can be explained by tectonic setting. For example regions along the active plate boundaries off the west coast, Cascadia

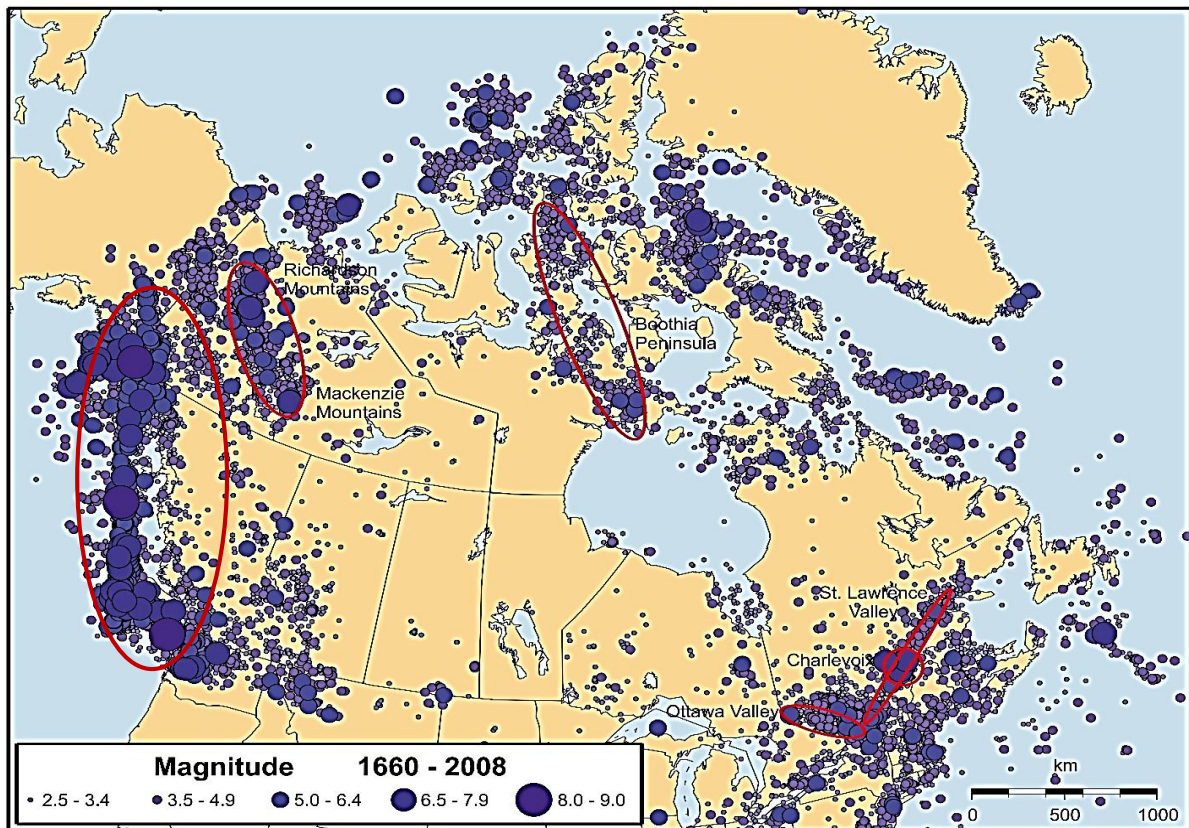

Figure 2-1: The Earthquake Distribution in Canada  
(Cassidy et.al, 2010)

fault, are facing the highest level of earthquake hazard in Canada. The hazard gradually reduces towards the east and the tectonic plates of Plains and specially Craton, where the fewest earthquakes occur, resulting in low earthquake hazard in cities such as Edmonton. The hazard increases again near the St. Lawrence and Ottawa valleys, in cities such as Ottawa, resulting in a moderate level of hazard. In the regions such as La Mal Baie, Quebec, and in the small areas in the Yukon and the high Arctic, the tectonic plate of Cordillera, a high level of seismic hazard is found (Cassidy et al., 2010; Rainer and Karacabeyli, 2000). The high risk associated with the level of seismic hazard described above poses an urgent need for seismic assessment of existing buildings to identify their needs for retrofit prior to the occurrence of a disaster.

## **2.2 Seismic Risk Assessment**

Seismic risk assessment can be defined as the estimation of the probability for building physical damage, number of fatalities, and economic losses caused by an earthquake (Ricci et al., 1981; Tesfamariam and Saatcioglu, 2008).

In seismic risk assessment of a building, three factors should be considered; site seismic hazard, building vulnerability (likelihood of failure) and building importance/exposure (consequence of failure) (Tesfamariam and Saatcioglu, 2008). Data needed for the site seismic hazard can be easily obtained from seismic hazard maps or through site inspection. Also, by considering the occupancy and use of a building, the importance of a building can be determined. However, building vulnerability cannot be estimated as easily as the other two factors. The expected performance of a structure facing an earthquake is revealed in a seismic vulnerability assessment. The outcome of this assessment is an estimation of the expected seismic damage in a building (Tesfamariam and Saatcioglu, 2008; Tesfamariam, 2008).

There are different methods used to perform a vulnerability assessment; empirical/statistical models, heuristic models, and analytical/mechanistic/theoretical models (Tesfamariam, 2008). In the following section, methods that have been used for seismic vulnerability assessment or seismic risk assessment in different countries are introduced.

## **2.2.1 Existing Methodologies for Seismic Risk Assessment**

### **2.2.1.1 Historical Background**

The process of risk estimation started by systematically recording weather and earthquakes in the late 19<sup>th</sup> century (Charles, 2005). John R. Freeman was first to demonstrate the advantages of risk reduction in his book *Earthquake Damage and Earthquake Insurance* in 1932, which was a study of the previous earthquakes and their consequences. 1990's was the beginning of the fast development of the risk assessment modeling using the support of governments and insurance companies especially in the US. This was presumably due to major earthquakes occurring during that period, such as the Northridge Earthquake in 1994 in Southern California and Kobe Earthquakes in 1995 in Japan. As a result, one of the best earthquake modeling methodologies in the US, HAZUS (Hazard United States), was created by the Federal Emergency Management Agency (FEMA) in 1990's, which later got extended to flood and hurricane in 2005. In the past 20 years, most of the risk assessment methods were developed in the United States, although, other countries such as Japan, New Zealand, and Canada have undertaken significant development and applied new methodologies of risk modeling (Gulati, 2006). These methodologies will be described next.

### **2.2.1.2 United States**

HAZUS (Hazard US) is a GIS-based software application for seismic risk assessment which was funded by the Federal Emergency Management Agency (FEMA) and developed by the National Institute of Building Sciences (NIBS) in 1997 to evaluate earthquake associated losses. In 2005, the second version of this tool, Hazard US Multi-Hazard (HAZUS MH) was launched and it included flood and wind hazards. Also in 2010, FEMA added loss estimation of hurricanes to the latest version of the HAZUS. This comprehensive multi-hazard risk assessment tool uses the GIS (Geographical Information System) technology combined with engineering and mathematical modeling to estimate damage (physical loss), casualties (social loss), and replacement costs of the damaged buildings (economic loss) resulted from a natural hazard. The GIS platform has been used to create a better visualization for users and permit them map losses.

In the earthquake assessment module of the software, five structural systems are considered such as wood framing, steel framing, concrete framing, reinforced concrete framing and

unreinforced concrete framing which was later classified further into 36 different structural classes based on their structural design and material used. The methodology is a combination of seven steps. In the first step, the required inputs (seismic data and structural characteristic of the building) are entered. In the second and third steps response spectra and capacity curves are generated. The output from the second and third steps is peak building response which constitutes the fourth step. The output of fourth step is used to generate fragility curves and to calculate the cumulative probabilities of model building type. The discrete probabilities for all damage states are then calculated and finally the Damage Probability Matrix for particular model building type is developed (Gulati, 2006).

The FEMA 154 Report (ATC, 2002) presents a rapid visual screening (RVS) method to estimate the potential seismic vulnerability of buildings. This handbook along with its companion FEMA 155 Report, which provides the technical basis for RVS and its system of scoring, are the second edition of similar documents first published by FEMA in 1988. The RVS is a fast and inexpensive method to identify seismically hazardous buildings and rank them accordingly without going through an expensive and time consuming detailed seismic analysis for each individual building. This methodology includes a “sidewalk survey” of a building and a Data Collection Form which is completed by the person who is performing the survey. The screener records his/her visual observation of the building from the exterior and, if possible, the interior, or based on structural drawings, or structural calculations. The Data Collection Form allows for documenting building identification information, including its use and size, a photograph of the building, sketches, and documentation of the data related to seismic performance, including the development of a numeric seismic hazard score. The RVS score typically ranges from 0 to 7 such that a higher score indicating better seismic performance. In the case of a low building score, a further detailed evaluation would be required. RVS is only the screening phase of a multi-phase procedure to identify seismically deficient buildings. Therefore, the low scored buildings in this phase must be assessed in more detail by an experienced seismic design professional to see if they are in fact seismically hazardous. Based on the final scores the screened buildings can be divided in two categories: those that are expected to be seismically adequate and those that are possibly hazardous during an earthquake.

Another FEMA report on seismic safety of existing buildings is FEMA 310, *Handbook for Seismic Evaluation of Buildings* (ASCE, 1998), which presents a detailed evaluation procedure for the buildings which in the RVS procedure were considered as potentially hazardous. It gives a three-tiered process for seismic evaluation of existing buildings considering all aspects of building performance including structural, nonstructural and foundation/geological. In tier-one, which is a screening phase, all aspects of the building seismic performance and also the site condition are rapidly evaluated using three checklists. In this phase, buildings having seismic deficiencies, or not meeting the requirements of FEMA 310, must continue to the tier-two evaluation. In tier-two, a linear static or dynamic analysis is performed in order to eliminate buildings that do not need rehabilitation. In this phase, if a building is considered deficient, the evaluator would need to proceed to tier-three, which is a detailed evaluation phase using nonlinear analysis. The analysis would evaluate the best mitigation technique to bring the seismic performance of a building to an acceptable level.

### **2.2.1.3 Developing Countries**

In 1997, the International Decade for Natural Disaster Reduction (IDNDR), operating under the mandate of the United Nations, funded a project with a goal to develop a risk assessment method called Radius (Risk Assessment Tools for Diagnosis of Urban Areas against Seismic Disasters). Most of the existing risk assessment methodologies had been developed in advanced countries and were for the most part not transferrable to developing countries (Villacis, 1999). In this method, buildings are classified in 10 categories based on their material type, construction type, seismic code, occupancy type and number of stories. The number of each type of building in each section of the city is estimated, and a vulnerability function, which is a function of acceleration based on damage observed during past sample earthquakes, is established (Villacis, 1999). The damage levels considered in this method are collapse and heavy damage. Vulnerability function is then generated using a two-step vulnerability assessment as follows (Gulati, 2006; Villacis and Cardona, 1999):

1. All the existing structural and infrastructure types of the city are identified and then representative ones are selected.
2. Existing vulnerability functions for the selected types are calibrated using data of past observed damage as well as the opinions and/or studies of local experts. For important and critical facilities, individual vulnerability studies are carried out.

#### **2.2.1.4 Japan**

During the 1968 Tokachi-oki Earthquake, reinforced concrete buildings in Japan experienced significant amount of damage, which questioned their level of safety and the need for vulnerability assessment of existing buildings. However it was after the 1995 Hyogo-ken Nanbu Earthquake that the authorities in Japan recognized and acted upon the urgent need for improving the seismic resistance of existing reinforced concrete buildings. Otani (2000) developed a procedure to test if a structure meets the required seismic resistance level of the building standard or whether there was a need to retrofit it. The factors that were considered in the vulnerability assessment method were; strength and deformation capability of constituent members, material properties on site, structural configuration, foundation, site conditions, soil-structure interaction, quality of workmanship, importance of buildings, year of construction, the installation of building facilities, the safety of non-structural elements, and hazard history. Furthermore, careful investigation of the building site to identify the exiting defects in the structure, such as existing cracks, uneven settlement, deflection under gravity loads, and rust on reinforcement, is mandatory in this method. By analyzing the building under lateral loading to failure, the lateral strength and deformation capacity of the building is estimated through ductility capacity, structural seismic capacity, and lateral force resisting capacity indices. If the results do not meet the acceptable level of strength or capacity, the building would need to be assessed further using nonlinear analysis.

#### **2.2.1.5 New Zealand**

The New Zealand Society for Earthquake Engineering, (NZSEE, 2006), presents a two stage seismic risk assessment procedure for all different types of buildings. In the first stage, an initial evaluation procedure (IEP) which is a visual screening process is performed to give a structural score to the building as an indicator of the potential earthquake damage, and identify, with a reasonable percentage of confidence, those buildings which are potentially prone to earthquake damage. In the second stage, those buildings which get a low score and are identified to be Earthquake Prone Buildings (EPB), will need to be assessed in more detail, using force-based or displaced-based method, in order to determine the potential risk and estimated damage. The assessment starts with surveying the building and gathering and recording data relevant to the building's seismic performance as the basis for assessment. Using this recorded data, the structural score is calculated by combining two scoring factors.

In the first one, soil type, site seismicity, building type, ductility, and building importance level are assessed. The second factor, takes into account any seismic deficiency found in the building. Then, using these two factors, the structural score is calculated and if the building does not achieve the acceptable score in the initial evaluation and is potentially earthquake prone, a detailed assessment is required.

### **2.2.1.6 Canada**

In Canada, the Manual for screening of buildings for seismic investigation (NRCC 1993), presents a seismic screening procedure for ranking buildings by modifying ATC-21 document (FEMA 154) published by US Federal Emergency Management Agency in 1988. In this modified procedure, the Canadian seismicity and building practice based on the 1990 edition of the National Building Code of Canada (NBCC) was considered. Also, the screening procedure is based on the field inspection of inside and outside of the building along with the review of structural drawings. This is a deviation from the FEMA 154 procedure, which only requires an inspection of the outside of the building. In addition, the non-structural hazards and the importance of the building, identified by its use and occupancy, are considered. A Screening Form is provided to collect the information on each building and to calculate its Seismic Priority Index (SPI) score. These key factors include seismicity, soil conditions, type of structure, irregularities of the structure, the presence of non-structural hazards, and also the building importance. Buildings with high SPI score can be potentially hazardous and must be evaluated in more detail by a professional engineer. The procedure presented in this manual is only the screening phase of a multi-phase seismic risk assessment of the buildings. In the next phase the potentially hazardous building is assessed in more detail (NRCC, 1993).

As mentioned before, the Screening Manual adopted the 1990 NBCC as the reference building code. However, since major changes were introduced to the NBCC in 2005, including updated seismicity and soil classifications, as well as the new ductility and over strength factors, the manual needed to be updated. Also, the seismicity in codes prior to the 2005 edition of the NBCC was determined using seismic zones. In the 2005 edition of NBCC the seismicity is defined using Uniform Hazard Spectra (UHS) specific for each location, which created a large volume of data, making it necessary to create a software to calculate the seismic screening indices for different buildings, with different periods, located in different Canadian

municipalities. The SCREEN software (Saatcioglu et al. 2011) was developed as a seismic screening tool presenting an updated version of the seismic screening manual developed.

## **2.3 Uncertainty in Seismic Risk Assessment and Fuzzy Logic as Solution**

In a seismic risk assessment, the subjective judgment of the assessor is always influencing the evaluation and decision making process. This means that the assessor, who is performing the assessment in a walk-down survey, may have a completely different opinion about the potential seismic vulnerability of a building compared to another assessor, because of the differences in their experience and knowledge. Also, the information provided by the assessor is in linguistic terms, such as *very high* or *very low* irregularity, which is difficult to quantify. Therefore, this qualitative judgment, the complexity of the assessment itself, and lack of available information, create uncertainty in the evaluation process which can best be handled through fuzzy logic (Zadeh, 1965). Fuzzy logic provides a mathematical way to represent vagueness and fuzziness and allows for linguistic and qualitative attributes to be translated into numerical reasoning (Tesfamariam, 2008; Ross, 2010). This mathematical mechanism within fuzzy logic is called Fuzzy Inference System (FIS) which is further explained in the following sections, along with fuzzy logic fundamentals used to create this system, including fuzzy sets, membership functions, and If-Then rules.

### **2.3.1 Fuzzy Sets and Membership Functions**

Fuzzy logic starts with the concept of a fuzzy set which is a set without any precisely defined boundaries. The elements of a fuzzy set can have different degrees of membership, either partial or complete. Whereas, members in a classical or crisp set are only allowed to have a complete or full degree of membership or no membership at all. Since the fuzzy set members can have partial membership, they can also be a member of another fuzzy set. For example, consider the set days which are part of the weekend. Monday, Tuesday, and Wednesday are unquestionably excluded, and Saturday and Sunday are surely included; but what about Friday? Technically it is not part of the weekend, but also, there is a feeling which says it is. Consequently, Friday can be a member of both sets weekdays and weekend with different degrees of membership. In a situation like this, classical sets which only accept full memberships are not practical anymore and we enter the territory of the fuzzy sets (MathWorks, 1997; Sivanandam et al., 2007). Uncertain quantity  $X$  can be a member of fuzzy

set A with a certain degree of membership  $\mu_x$  which ranges from 0 to 1, where 0 means no membership and 1 means full membership (Tesfamariam and Saatcioglu, 2008).

The degree of membership in a fuzzy set is defined by a curve called membership function. It specifies how each point on the input space is getting a membership value from 0 to 1. The input space, or *universe of discourse*, is the space of all the information available for a given problem and includes the fuzzy sets (Ross, 2010; MathWorks, 1997). The membership functions can have different shapes; triangular, trapezoidal, bell shaped, and Gaussian curves. But the simplest one that is suitable for representing linguistic variables is triangular (Tesfamariam, 2008). It is a simple triangle formed by three points called Triangular Fuzzy Numbers (TFN). Selection of the suitable shape for membership functions and also the TFNs, completely depends on the user's knowledge of the problem at hand (Sivanandam, et al., 2007; Tesfamariam, 2008). For example, the shape of the membership functions and the TFNs considered for the level of building irregularity, as the problem, completely depends on expert opinion. The term "expert opinion" is based on a group of experts in the field, with knowledge and maybe even some historic performance evidence, but that does not mean it is a "fact".

The membership functions are the adjectives which describe the input or output variables. To create a fuzzy logic system, first the input and output variables need to be specified. In a fuzzy system, input and output variables are linguistic variables whose values are words or sentences from a natural language (MathWorks, 1997). Each variable includes a set of membership functions which describe them. For example, Figure 2-2 represents the fuzzy sets and their membership functions, developed based on expert opinion, to determine the degree of membership or truth value of a level of plan irregularity (PI), which is considered the input variable here. In this example, 5 different levels (fuzzy sets) has been considered for plan irregularity (input variable) using triangular membership functions. These levels (fuzzy sets) are expressed as *very low*(VL), *low*(L), *moderate*(M), *high*(H), and *very high*(VH), with triangular fuzzy numbers [TFN(0,0,0.25); TFN(0,0.25,0.5); TFN(0.25,0.5,0.75); TFN(0.5,0.75,1.0); TFN(0.75,1.0,1.0)] respectively. These numbers define the interval for each membership function. Consider, in a walkdown survey, the assessor identifies high plan irregularity in a building as a result of observing that the shape of the building is irregular (e.g. T or L shape building). The transformation value for *high* plan irregularity is 0.7 which is

chosen based on expert opinion from the input space. The membership functions transform this value to a membership value from 0 to 1 for each fuzzy set. Therefore, membership values for *high* plan irregularity are ( $\mu_{VL} = 0.0, \mu_L = 0.0, \mu_M = 0.2, \mu_H = 0.8, \mu_{VH} = 0.0$ ). It means that a high plan irregularity has 20% degree of membership in *moderate* and 80% degree of membership in *high* fuzzy sets.

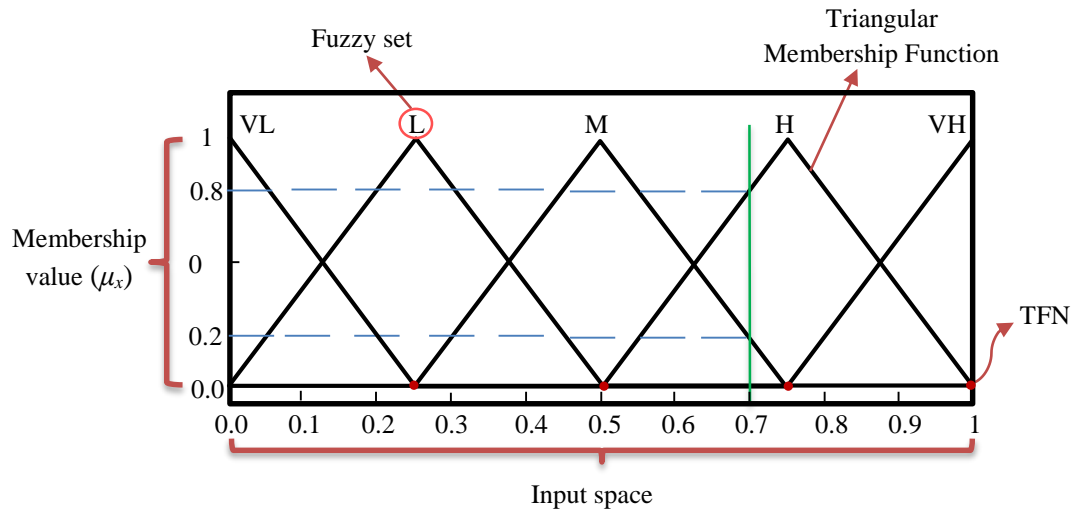

Figure 2-2: Membership Functions and Fuzzy Sets of the Input Variable, Vertical Irregularity

### 2.3.2 If-Then Rules

In a fuzzy logic system an input space is mapped to an output space using conditional statements called rules or If-Then rules. These rules are a collection of linguistic statement which make a fuzzy system useful, since they create a connection between all the elements of a fuzzy system, including input variables, output variable, and the adjectives which describe them (membership functions) (MathWorks, 1997). Fuzzy rules are always written in the following form (Sivanandam et al., 2007):

**IF** (*input 1 is membership function 1*) **AND/OR** (*input 2 is membership function 2*) **AND/OR** . . . **THEN** (*output n is output membership function n*); or by using Equation 2-1 as follows (Tesfamariam, 2008):

$$\mathbf{R}_i: \mathbf{IF} X_1 \text{ is } A_{i1} \mathbf{AND} X_2 \text{ is } A_{i2} \mathbf{THEN} Y \text{ IS } B \text{ for } i=1,2,\dots,N \quad [2-1]$$

Where:

- $R_i$  represents the  $i^{\text{th}}$  rule

- $X_1$  and  $X_2$  are the input variables (antecedents)
- $N$  is the total number of rules
- $A_{i1}$  and  $A_{i2}$  are the input membership functions (Input fuzzy sets)
- $Y$  is the output variable (consequent)
- $B$  is the output membership function (output fuzzy set)

The sequence of the rules is not important and they are evaluated in parallel. If there are multiple parts to the antecedent, fuzzy logic operators should be applied. These operators include *AND* (*Intersection*), *OR* (*Union*), and *NOT* (*complement*) operators corresponding to the *min*, *max*, and *complement*, respectively, and are defined as Equation 2-2 (Sivanandam et al., 2007):

$$\begin{aligned}\mu_{A \cap B} &= \min [\mu_A(x), \mu_B(x)] && [2-2] \\ \mu_{A \cup B} &= \max [\mu_A(x), \mu_B(x)] \\ \mu_{\bar{A}} &= 1 - \mu_A(x)\end{aligned}$$

For example, consider the plan irregularity (PI) and vertical irregularity (VI) as two input variables in the fuzzy system. As will be further discussed in Chapter 3, the aggregation of plan and vertical irregularity will result in the increase in seismic demand, or increase in demand (ID), which is considered the output of the fuzzy system here. Since there are 2 inputs, each having 5 membership functions, there has to be at least  $5^2=25$  rules considered for this fuzzy rule base (FRB) system, each one developed based on expert opinion. Here is one of the rules established for this example using Equation 2-1:

**IF** *vertical irregularity (VI)* is *very high (VH)* **AND** *plan irregularity* is *very high (VH)* **THEN** *increase in demand (ID)* is *very high (VH)*

Complete rule-base system for this example is illustrated in Table 2-1.

**Table 2-1: The fuzzy rule base system developed for evaluating the increase in seismic demand (ID) of a building**

				$\mu VI$				$\mu PI$				$\mu ID$ (Min $\mu VI$ & $\mu PI$ )
R <sub>1</sub>	IF	VI	VL	0.0	AND	PI	VL	0.0	THEN	ID	VL	0.0
R <sub>2</sub>	IF	VI	VL	0.0	AND	PI	L	0.0	THEN	ID	VL	0.0
R <sub>3</sub>	IF	VI	VL	0.0	AND	PI	M	0.0	THEN	ID	L	0.0
R <sub>4</sub>	IF	VI	VL	0.0	AND	PI	H	0.4	THEN	ID	M	0.0
R <sub>5</sub>	IF	VI	VL	0.0	AND	PI	VH	0.6	THEN	ID	M	0.0
R <sub>6</sub>	IF	VI	L	0.0	AND	PI	VL	0.0	THEN	ID	VL	0.0
R <sub>7</sub>	IF	VI	L	0.0	AND	PI	L	0.0	THEN	ID	VL	0.0
R <sub>8</sub>	IF	VI	L	0.0	AND	PI	M	0.0	THEN	ID	L	0.0
R <sub>9</sub>	IF	VI	L	0.0	AND	PI	H	0.4	THEN	ID	M	0.0
R <sub>10</sub>	IF	VI	L	0.0	AND	PI	VH	0.6	THEN	ID	M	0.0
R <sub>11</sub>	IF	VI	M	0.20	AND	PI	VL	0.0	THEN	ID	L	0.0
R <sub>12</sub>	IF	VI	M	0.20	AND	PI	L	0.0	THEN	ID	L	0.0
R <sub>13</sub>	IF	VI	M	0.20	AND	PI	M	0.0	THEN	ID	M	0.0
R <sub>14</sub>	IF	VI	M	0.20	AND	PI	H	0.4	THEN	ID	M	0.2
R <sub>15</sub>	IF	VI	M	0.20	AND	PI	VH	0.6	THEN	ID	H	0.2
R <sub>16</sub>	IF	VI	H	0.80	AND	PI	VL	0.0	THEN	ID	M	0.0
R <sub>17</sub>	IF	VI	H	0.80	AND	PI	L	0.0	THEN	ID	M	0.0
R <sub>18</sub>	IF	VI	H	0.80	AND	PI	M	0.0	THEN	ID	H	0.0
R <sub>19</sub>	IF	VI	H	0.80	AND	PI	H	0.4	THEN	ID	H	0.4
R <sub>20</sub>	IF	VI	H	0.80	AND	PI	VH	0.6	THEN	ID	VH	0.6
R <sub>21</sub>	IF	VI	VH	0.0	AND	PI	VL	0.0	THEN	ID	M	0.0
R <sub>22</sub>	IF	VI	VH	0.0	AND	PI	L	0.0	THEN	ID	M	0.0
R <sub>23</sub>	IF	VI	VH	0.0	AND	PI	M	0.0	THEN	ID	H	0.0
R <sub>24</sub>	IF	VI	VH	0.0	AND	PI	H	0.4	THEN	ID	VH	0.0
R <sub>25</sub>	IF	VI	VH	0.0	AND	PI	VH	0.6	THEN	ID	VH	0.0

### 2.3.3 Fuzzy Inference System (FIS)

The goal of using fuzzy logic in a system is to conveniently map given inputs to the appropriate outputs. This is done through a process called Fuzzy Inference System (FIS), which involves all the fuzzy logic fundamentals discussed before (Math Works, 1997). FIS consists of four components: the fuzzifier, inference engine, rule base, and defuzzifier. The inference engine within a fuzzy system defines the relationship between input fuzzy sets and

output fuzzy sets. The most commonly used inference engine is Mamdani (Mamdani, 1977). The working of FIS using Mamdani's system is described next.

Before starting the fuzzy inference process, the linguistic variables (input and output), the membership functions, and also the rule base need to be defined and constructed by the user, as a part of the initialization stage as illustrated in Sections 2.3.1 and 2.3.2 (Math Works, 1997). Continuing with the previous example involving a building with both vertical and plan irregularity, the two input variables (plan irregularity (PI) and vertical irregularity (VI)) and one output variable (Increase in demand (ID)) need to be defined. Five triangular membership functions are constructed for each input and output variable using the same values used in the first example (Figure 2-3). Also, the rule base system is established as illustrated in Table 2-1. Now, all the elements of the initialization phase are defined and ready to be used in the fuzzy inference system.

Next, as the first step, the fuzzy inference process starts with fuzzifying the input variable, by assigning a degree of truth between 0=FALSE and 1=TRUE to the adjectives which describe input variables (all the statements of the IF part of the rules) using membership functions. For example, consider in the evaluation process of a building, the assessor identifies the level of plan irregularity and vertical irregularity, as *very high (VH)* and *high (H)*, respectively. The transformation values already considered for these two linguistic terms, based on expert opinion are 0.9 for *VH* plan irregularity and 0.7 for *H* vertical irregularity. These crisp values first get fuzzified using the membership functions already defined, and get a membership value from 0 to 1 ( $\mu_{VI}$  and  $\mu_{PI}$ ). These fuzzified values of VI and PI are ( $\mu_{VL}^{VI}=0.0$ ,  $\mu_L^{VI}=0.0$ ,  $\mu_M^{VI}=0.2$ ,  $\mu_H^{VI}=0.8$ ,  $\mu_{VH}^{VI}=0.0$ ) and ( $\mu_{VL}^{PI}=0.0$ ,  $\mu_L^{PI}=0.0$ ,  $\mu_M^{PI}=0.0$ ,  $\mu_H^{PI}=0.40$ ,  $\mu_{VH}^{PI}=0.60$ ) respectively. After fuzzifying the inputs, in the second step, if the antecedent is made up of multiple statements, and the connectives (AND or OR) are used, the fuzzy operator, based on the connectives used, resolves the statements into a number between 0 to 1 (Math Works, 1997), as seen in Table 2-1.

In the third step, the value calculated in the first two steps, shapes the fuzzy set specified in the consequent (VL, L, M, H, or VH), using the implication operator (min). The previous steps occur for all the rules. Consequently, each rule has a fuzzy set as an output (Math Works, 1997), as seen in the Figure 2-3.

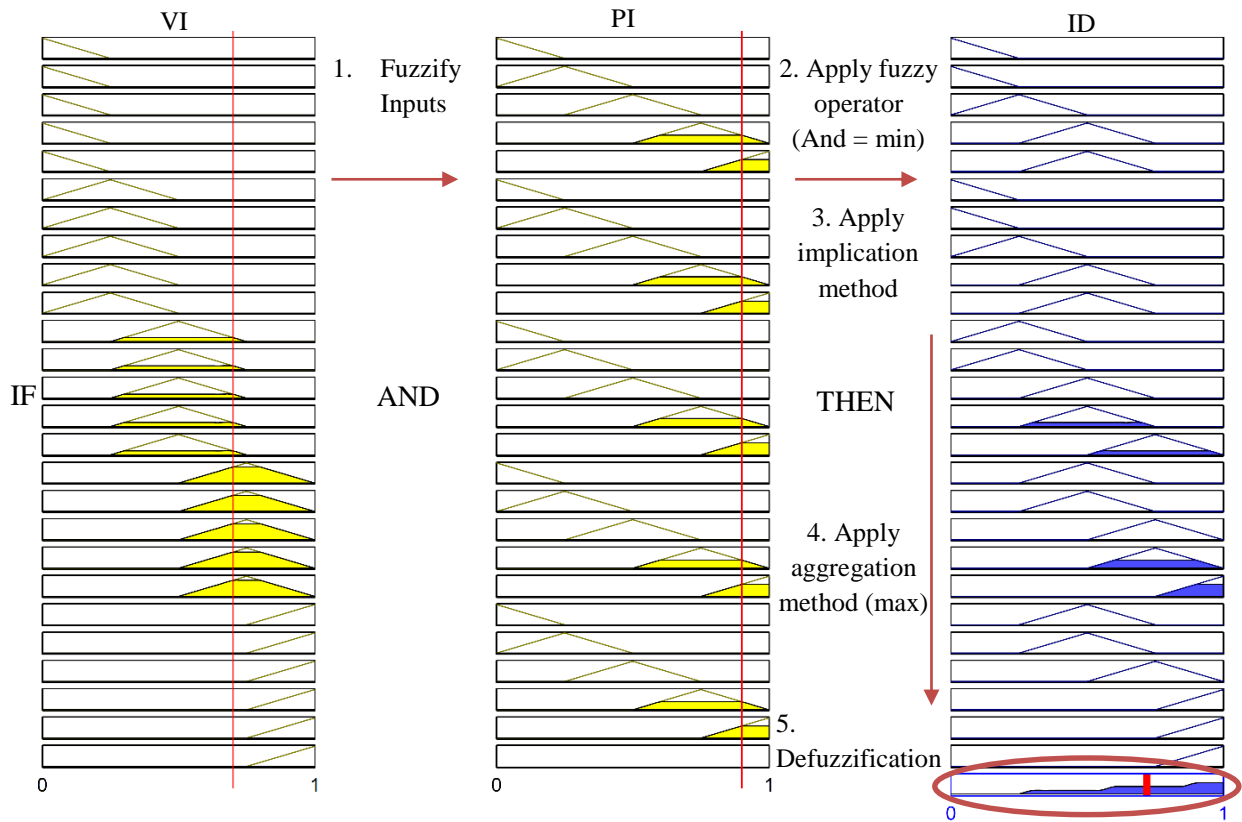

**Figure 2-3: Graphical Illustration of the Example Fuzzy Inference System** (MathWorks, 1997)

In the next step, using the aggregation operator, the rules are aggregated to find the membership values of the output variable and the fuzzy sets are joined to each other to create a single membership function. In the example presented here, using maximum operator, the rules are aggregated to obtain the membership values of the output variable (ID) (Math Works, 1997), as seen in Table 2.2. The resultant shape of these fuzzified values is illustrated in Figure 2-3, highlighted by an ellipsoid, and Figure 2-4.

**Table 2-2: The Aggregation Process of the Example Rules**

$\mu_{VL}^{ID}$	$\text{Max}(0,0,0,0) = 0$
$\mu_L^{ID}$	$\text{Max}(0,0,0,0) = 0$
$\mu_M^{ID}$	$\text{Max}(0,0,0,0.2,0,0,0,0,0) = 0.2$
$\mu_H^{ID}$	$\text{Max}(0.2,0,0.4,0) = 0.4$
$\mu_{VH}^{ID}$	$\text{Max}(0.6,0,0) = 0.6$

The final step is the defuzzification. The single fuzzy set resulted in the last step is reduced to a single crisp value in the defuzzification process. The centroid or center of area is the most common defuzzification method which calculates the center of area of the aggregated fuzzy set created in the last step (Math Works, 1997). To continue the example, the fuzzy set created in the last step gets defuzzified using the centroid method to obtain the crisp value of increase in demand as seen in Figure 2-4. The final result of this fuzzy inference system process is 0.72, meaning that *high* vertical irregularity and *very high* plan irregularity in this building will result in increase in seismic demand with the value of 0.72 which will be used further in the seismic evaluation process.

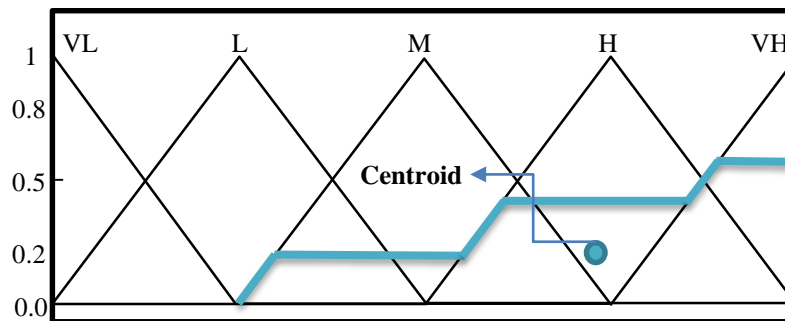

Figure 2-4: Center of Area Calculated in the Defuzzification Phase of the Example FIS

## 2.4 Seismic Vulnerability of Wood Frame Construction

Modern wood frame buildings have performed well in earthquake events, with low fatality rates. Even in strong shaking, many buildings have survived with various degrees of structural and non-structural damages, and with only few collapses (Rainer & Karacabeyli, 2000; CWC, 2003.). Several sources in the literature (Graf, 2008; Rainer & Karacabeyli, 2000; CWC, 2003; NRCC, 1993) attribute the good seismic performance of wood frame construction to the following factors:

- **Strength and stiffness:** In wood frame construction, braced walls or shearwalls, especially if sheathed by wood structural panels (OSB or plywood), provide a very effective system to resist the racking forces of the earthquake. In addition, numerous non-structural elements contribute to the seismic force resistance of the structure.

- **Ductility:** The inherent ductility in the wood frame construction dissipate earthquake energy. The source of this ductility is the numerous nailed joints within the wood structure.
- **Weight:** The seismic force generated by an earthquake in a structure is proportional to its weight. Since the wood frame construction is lightweight, it is expected to have a relatively good performance in an earthquake.
- **Redundancy:** There are numerous load paths in a wood frame construction to transfer the seismic loads to the ground. This provides redundancy and increases the level of life safety. Instead of having small number of big connections, there are many small joints which can resist the extra load shared by the overloaded adjacent joint.
- **Connectivity:** In a wood frame construction, all the structural elements including walls, floors, and roofs are strongly connected to each other and to the foundation below providing a “single solid structural unit” which greatly helps building to be held together during an earthquake.

While wood framed buildings have shown good performance from the perspective of life-safety, damage is still observed in these buildings during earthquakes. Damage often occurs in the connections between the main seismic load resisting subsystems, such as shearwalls and diaphragms or shearwalls and foundation. Knowledge about the types and locations of such weak links observed in post damage assessments can provide useful clues for the development of seismic evaluation of existing buildings (CUREE, 2010). Following is a short summary of seismic performance of wood frame construction observed in past major earthquakes.

#### **2.4.1 Performance of Wood Frame Construction in Previous Earthquakes**

Nail bending and slip, sliding and overturning of wall piers, shear failures in wall sheathing, various connection failures, and crushing of boundary members are examples of failure modes which can happen in wood frame construction during an earthquake, as a result of structural or non-structural deficiencies, creating significant damage in the building (Graf, 2008).

Canada has experienced significant earthquakes in the 20<sup>th</sup> century (e.g., Messina NY – Cornwall ON 1944, Courtney BC 1946, Miramichi NB 1982, Nahanny NT 1985, Saguenay QC 1988), but they were either not strong enough or not located in populated areas to cause

widespread damage. Therefore, wood frame construction in Canada has not been exposed to damaging earthquakes and lessons need to be drawn from the experience of other countries having the same type of wood frame housing, such as the United States, New Zealand and Japan (Rainer and Karacabeyli, 2000). Table 2-3 summarizes seismic performance of wood frame construction observed in previous earthquakes in these countries (Graf, 2008; Rainer and Karacabeyli, 2000; CWC, 2003; NIBS 2006; Falk and Soltis, 1988).

**Table 2-3: Documented Seismic Performance of Wood Frame Construction in Previous Earthquakes**

<b>Earthquake</b>	<b>Richter Magnitude</b>	<b>Observations</b>
1925 Santa Barbara & 1933 Long Beach (United States)	6.3  6.4	<ul style="list-style-type: none"> <li>• Immediate need for developing seismic design codes and a requirement to attach wood-framed walls to reinforced concrete or masonry foundations because of high level of damage to the dwellings.</li> </ul>
1971 San Fernando (United States)	6.7	<ul style="list-style-type: none"> <li>• It accrued in the suburban area of Los Angeles affecting a large number of single-family dwellings</li> <li>• Older wooden houses suffered damage ranging from minor to partial collapse while newer two-story apartment buildings with large ground-level openings were severely affected</li> <li>• Houses sliding off the foundations because of no anchorage to the foundation, collapse of “cripple walls” in crawl space, collapse of add-ons such as porches, collapse of masonry chimneys, and major distortion of weak first story were the primary cause of damage</li> <li>• It was indicated that two-story and split-level homes with large garage openings at ground level are particularly susceptible to damage.</li> <li>• Considering the life safety factor the newer wooden houses performed well</li> </ul>

<p>1987 Edgecumbe (New Zealand)</p>	<p>6.3</p>	<ul style="list-style-type: none"> <li>• The wood frame houses in this area were built on concrete strip or concrete block foundations having a crawl space below the ground floor.</li> <li>• Most of the walls were sheathed using gypsum board on the interior side and on the exterior they were covered by brick veneer</li> <li>• No exterior sheathing was applied and instead K-bracing or diagonal bracing members were used</li> <li>• Houses sliding off the foundation, cracking and collapse of the brick veneer on the building exterior, collapse of chimneys and failure of foundation posts were the primary cause of damage.</li> </ul>
<p>1988 Saguenay (QC, Canada)</p>	<p>5.7</p>	<ul style="list-style-type: none"> <li>• Damage was limited to cracks in chimneys, foundations and brick veneer walls, mostly because of foundation soil displacement not the structural weaknesses</li> <li>• No case of near collapse or fatality</li> </ul>
<p>1989 Loma Prieta  1994 Northridge (United States)</p>	<p>7.1  6.7</p>	<ul style="list-style-type: none"> <li>• Soft/weak story conditions generally created by tuck-under parking, seismic vulnerability of stucco and gypsum wall-board construction, inadequate braced walls, and slide off foundation because of no connection to the foundation, were primary cause of damage.</li> <li>• Single-family houses sliding down a hillside and collapsing was also observed</li> <li>• Chimneys were severely damaged as seen in the other earthquakes</li> </ul>
<p>1995 Hyogo- ken Nanbu (Kobe) (Japan)</p>	<p>6.8</p>	<ul style="list-style-type: none"> <li>• Wood building built exactly after World War II faced the most damage including post and beam buildings with walls sheathed by horizontal boards and in-filled by bamboo webbing and covered by clay.</li> <li>• Heavy roofs built of burnt clay tiles showed its huge damageability in the earthquake.</li> <li>• In contrast with old wood buildings, the modern wood frame construction showed a very good seismic resistance.</li> </ul>

In Table 2-4, total number of people killed in aforementioned earthquakes and the number of casualties in wood frame construction is summarized. These numbers obviously show the low fatality percentage in wood frame construction considering large number of wood buildings effected by earthquake (Rainer and Karacabeyli, 2000).

**Table 2-4: Overview of casualties in the previous major earthquakes (Rainer & Karacabeyli, 2000)**

Earthquake	Richter Magnitude M	No. of Persons Killed		No. of Platform-frame Wood Houses Strongly Shaken (estimated)
		Total	In Platform-frame Wood Houses	
San Fernando CA, 1971	6.7	63	4	100 000
Edgecumbe NZ, 1987	6.3	0	0	7 000
Saguenay QC, 1988	5.7	0	0	10 000
Loma Prieta CA, 1989	7.1	66	0	50 000
Northridge CA, 1994	6.7	60	16 + 4*	200 000
Hyogo-ken Nambu, Kobe Japan, 1995	6.8	6 300	0**	8 000**

\* “16 deaths occurred in the collapse of one apartment building. Four deaths were from foundation failures that caused collapse of buildings on hillsides”

\*\* “Pertains to modern North American style wood frame houses in the affected area”

### 2.4.2 Seismic Deficiencies of Wood Frame Construction

Observations made after earthquakes have presented valuable lessons on the seismic behaviour of wood-framed buildings. Most critical seismic deficiencies of wood frame construction that had been highlighted in past earthquakes are summarized below:

#### 1. *Weak and brittle shear wall sheathing materials*

Gypsum wallboard (drywall) and stucco (cement plaster) were commonly used as the sheathing materials for the wood-framed shearwalls in US in the period between 1960’s to 1980’s. These products crack and lose both strength and stiffness under cyclic motion of the earthquake. During that period, high level of shear capacity was

considered for these materials in seismic design. Therefore, wood-framed buildings that only use these materials as the sheathing for shearwalls are likely to experience high levels of damage (Graf, 2008).

## 2. *Inadequate Cripple Wall Bracing*

Cripple Walls are short walls built around the crawl space that connect foundation to floor base. These walls were common in houses built before 1960, pre-dating slab-on-grade foundations. Poorly braced cripple walls have been the cause of significant damage in wood-framed dwellings in numerous historical earthquakes as seen in Figure 2-5. The vulnerability of these walls is primarily due to their inadequate in-plane strength or inadequate anchorage to the foundation. (Graf, 2008; NIBS, 2006).



**Figure 2-5: Failure of Cripple Wall in Loma Prieta Earthquake**  
(Photo: C.Stover, U.S. Geological Survey)

## 3. *Sill Plates or Floor Framing Without Approved Foundation System*

Some older dwellings do not have a foundation system. Instead, the wall sill plate, and much of the floor framing, is supported directly on the ground. When subjected to the vertical and lateral forces due to earthquakes, these structures can easily move, due to the lack of anchorage provided. This movement can cause a variety of structural and non-structural damages, including broken gas or utility lines, which can lead to fire. Also, because there is no suitable separation between the wood and the soil, both fungus and insect attacks can occur in the structure. Wood deterioration caused by this can be a source of damage during an earthquake. (NIBS, 2006)

4. *Inadequate Sill Plate Anchorage.*

Older (usually pre-1940) houses are often not bolted to their foundation which causes the building to slide off the foundation during an earthquake (Graf, 2008).

5. *Unreinforced Masonry Perimeter Foundation*

Unreinforced masonry foundation often lacks the required strength to resist earthquake forces especially in high seismic regions. They are common in older buildings built before the adoption of seismic codes in high seismic regions. They are even used in newer dwellings where codes have not been enforced. They easily get damaged during an earthquake causing building to shift off the foundation. (NIBS, 2006)

6. *Unreinforced brick and stone masonry chimneys*

Many masonry fireplaces and chimneys used in wood framed buildings are usually heavy, rigid, and brittle. In an earthquake, their movement can be significantly different from the movement of the building itself, thereby causing damage to the building. Damage to the chimney itself could cause hazard to passerby, as seen in Figure 2-6 (NIBS, 2006).



**Figure 2-6: Chimney Damage in Northridge Earthquake**

(Photo: J.Dewey, U.S. Geological Survey)

7. *Fragile or poorly attached masonry and stone veneers.*

Masonry and stone veneers have been damaged in numerous earthquakes due to their inadequate connection to the wall studs and the top and bottom plates. After their failure they are able to pull out the sheathing and the studs from the wall causing more damage (NIBS, 2006).

8. *Split-Level Floor Interconnection*

Split-level houses have experienced partial collapse and significant damage during earthquakes. These houses have vertical offsets in the floor framing elevation on either side of a common wall. Earthquake damage occurs when sections of floor and roof framing is pulled away from the common wall (NIBS, 2006).

9. *Soft- and weak-story conditions created by tuck-under parking*

In buildings with tuck-under parking, garage door opening usually replaces the needed shearwall, creating a weak story at the ground floor. During an earthquake, these garages may sway and collapse, causing significant damage as seen in Figure 2-7. This deficiency was unrecognized until the 1989 Loma Prieta and 1994 Northridge earthquakes where such buildings suffered heavy damage (Graf, 2008).



**Figure 2-7: Failure in a Typical Wood Frame Construction Caused by Soft Story, in Loma Prieta Earthquake (Left) and Northridge Earthquake (right)**  
(ATC, 2012)

10. *Hillside buildings*

These buildings are vulnerable to landslide, and if not properly braced, they are subjected to torsion. In an earthquake, the floor framing of the hillside homes is pulled away from the uphill foundation creating significant damage (Graf, 2008).

11. *Foundation deficiencies*

Cut-and-fill lots, sloped or stepped foundations, liquefaction, and landslide create unstable foundation to resist the forces generated by an earthquake. For example liquefaction can cause differential settlement and distress to the structure or the

landslides can dislocate the structure entirely (Graf, 2008; Rainer and Karacabeyli, 2000).

### **2.4.3 Irregularity in Wood Frame Construction**

Configuration of a building is very dominant in its seismic behaviour. In general, buildings with regular shapes, uniformly and symmetrically distributed shearwalls, no weight concentrations, no large openings, and no floor level offsets, can have a very good seismic behaviour. Meanwhile, any type of irregularity, not considered during the design process, can cause damage to the building in an earthquake (NIBS, 2006). Eight types of building irregularities has been introduced in the 2010 edition of the NBCC, including: vertical stiffness irregularity, weight (mass) irregularity, vertical geometric irregularity, in-plane discontinuity in vertical lateral load resisting element, out of plane offsets, discontinuity in capacity(weak story), and torsional sensitivity (NRCC, 2010).

Generally, the irregularities can be divided into two main types: plan irregularity and vertical irregularity. Plan irregularities concentrate earthquake loads in a particular section of a building due to non- uniformed distribution of the mass or the shearwalls in a building, or irregular building plan. The most common plan irregularities are T and L shaped buildings. In these buildings earthquake loads are concentrated at the corner where the building wings are connected (NIBS, 2006). Following is a list of common plan irregularities in wood frame construction reproduced from the FEMA 232 document (NIBS, 2006):

1. A section of floor or roof is not laterally supported by shearwalls or braced wall lines on all edges. Also called an “Open Front” irregularity.
2. An opening in a floor or roof exceeds the lesser of 50 percent of the least floor or roof dimension.
3. Shearwalls and braced wall lines do not occur in two perpendicular directions.
4. The addition of balconies and decks creates additional weight and increases earthquake loads, a fact that was not envisioned when required bracing lengths were determined.
5. Stories braced by light-frame walls include concrete or masonry construction.

Vertical irregularities in a multistory building, concentrate damage in one story. This is when that particular story has lower stiffness or strength compared to adjacent stories. The

story with lower stiffness is called soft story. In light wood frame dwellings, since the lower stories usually have more windows and door openings and less shearwalls than the upper stories, soft story phenomena can occur (NIBS, 2006). Following is a list of common vertical irregularities in wood frame construction reproduced from the FEMA 232 document (NIBS, 2006):

1. Exterior shear wall lines or braced wall panels are not in one plane vertically from the foundation to the uppermost story in which they are required.
2. The end of a braced wall panel occurs over an opening in the wall below and ends at a horizontal distance greater than 1 foot (305 mm) from the edge of the opening.
3. When portions of a floor level are vertically offset. Also called “Split Level” irregularity.
4. Cripple walls around the perimeter of a crawlspace
5. Tuck Under garages

#### **2.4.4 Construction Quality of Wood Frame Construction**

Good seismic codes and good design are not enough to deliver good seismic performance for wood-framed buildings. Of equal importance is construction quality, requiring good materials and workmanship. The construction process of wood-framed buildings is fraught with problems and places to error which reduces its construction quality, and consequently its seismic resistance (Senft, 2003). Some areas of concerns can be summarized as follows (Fowler, 1998; NIBS, 2006, Brook, 2007).

1. *Driving the nails through the sheathing but missing the framing*

Sloppy work with pneumatic nail gun causes this error, as seen in Figure 2-8. Using the nail gun, it is very hard for the operator to feel if the nail has been driven into the framing member behind, which results in inadequately attached sheathing to the framing.



**Figure 2-8: Nails Missing the Truss**  
(Fowler, 1998)

2. *Overdriving the nails attaching the sheathing to the framing*

This is also an error caused by using pneumatic or power-driven nail guns. Overdriving nails especially around the perimeter of sheathing panels which provides the strength and stiffness of the panel severely decreases the connection's strength.

3. *Locating the nails too close to the edge of the sheathing panel*

Nails too close to the edge will tear out the sheathing panel, reducing the strength of the wall.

4. *Improper toe nailing*

Toe nailing, especially in conventional construction, is used to transfer loads between structural elements, so it must be done correctly in a way that the nails do not split the wood.

5. *Failure to carry an interior shearwall all the way to the roof diaphragm*

Shearwalls transfer lateral loads from the roof diaphragm to the foundation, so it is essential to keep its vertical continuity. Figure 2-9 is an example of this common error.



**Figure 2-9: The Sheathing Panel on the Interior Shearwall not extended to the Roof Diaphragm**  
(Fowler, 1998)

6. *The shear panels not being extended across the entire width of the shearwall area*  
This way the sheathing does not cover the whole system and does not reach the post and hold-down that make the system complete.
7. *Attaching the hold-downs to the wrong members*  
This error creates a shorter shearwall than what was intended.
8. *Improper installation of joist and beam hangers.*  
These metal connectors are often bent, cut or twisted out of shape or miss some nails.
9. *Cutting I-joist or floor sheathing to install wiring and plumbing*  
It is a common practice to just cut joists and floor sheathing to install wiring and plumbing, creating weak spots and reducing their load capacity.
10. *Skipping the required spacing between the joists*  
This reduces the load transfer between structural components.
11. *Allowing moisture to seep through the building*  
It is due to the poor workmanship and the purchase of faulty building materials for the roof which can cause mold, mildew, or even dry rot.

## 2.5.5 Evolution of Wood Frame Construction in US and Canada

### 2.5.5.1 United States

The seismic vulnerability of wood frame construction changes with the year of construction. Through time, lessons learned from the previous earthquakes are incorporated in the building codes, resulting in advancement in seismic design and construction practice (Schmid, et al., 1994). Figure 2-10 illustrates the evolution of wood frame construction in the United States under Uniform Building Code (UBC) (Graf, 2008).

One of the major changes in code provisions were made for the buildings with tuck under garages. In the period between 1960s to early 1970s, considerable number of multistory wood frame buildings were built in western United States, having tuck under garages. Considering seismic deficiencies of this type of light wood frame construction, as mentioned in Section 2.4.2, the UBC revisions in 1976 and 1988 increased the seismic load requirements for buildings with tuck under garages. However this did not completely eliminate the design with tuck under parking, but discouraged it. Modern buildings with tuck under garages need to consider some additional structural systems along the open face of the building in order to eliminate the soft story issue (Graf, 2008).

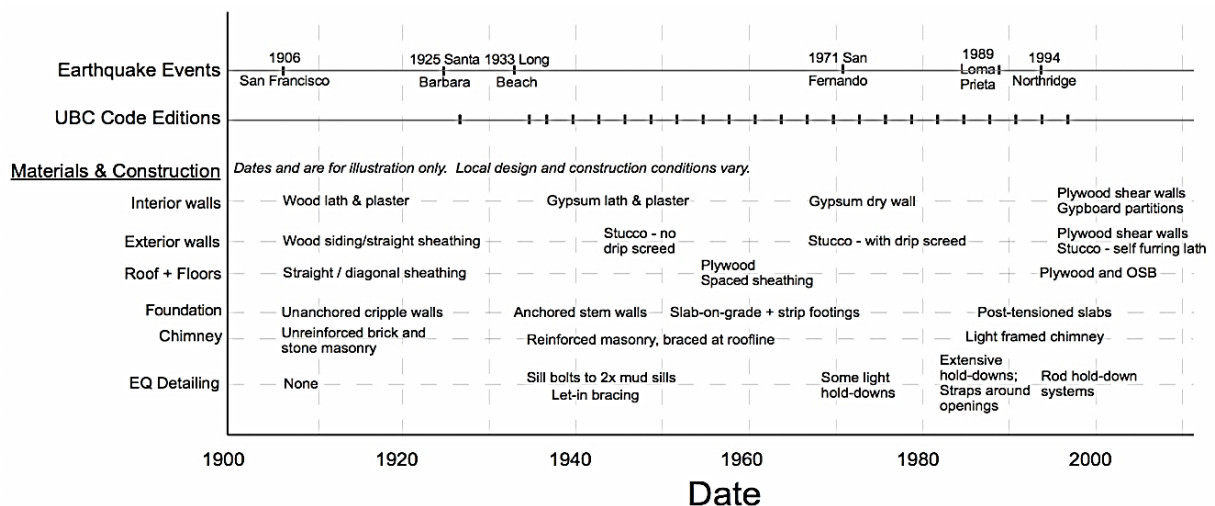

Figure 2-10: Evolution of Wood Frame Construction in United States under UBC (Graf, 2008)

In 1988, another major change was made to the provisions of UBC for light wood frame buildings. In the period between 1960's to 1980's, high shear capacity was considered for gypsum wallboard and stucco in the UBC code, and low-rise wood frame buildings in the US relied on the high shear resistance of these materials. However, considering the seismic deficiencies of these materials, in 1988 the UBC reduced their allowable shear values by half. As illustrated in Figure 2-10, plywood and OSB are now being used as the main sheathing for shearwalls, especially after the Northridge Earthquake. (Graf, 2008)

In order to reduce the damage observed in wood frame construction following the Northridge Earthquake, numerous changes were made to the UBC and also to the other local codes in the US. For example, the shear capacity considered for gypsum wallboard and stucco got further reduced and they were not permitted to be used in the lower stories, where seismic forces are high. Instead, using wood structural panels (OSB or plywood) for shearwalls was encouraged in the new code provision. Such changes are the chief contributor to the significant improvement to the performance of wood-framed buildings built and designed after the Northridge Earthquake, in compliance with the new codes (Graf, 2008).

#### *2.5.5.2 Canada*

Pre-1940 wood frame construction was built mostly using wood boards and full-dimensioned lumber that was adequately connected by hand driven nails. After the Second World War, the Canadian housing industry expanded enormously and new products were introduced to wood frame construction. In 1940's, sheathing products such as plywood, fiber board and gypsum wallboard widely replaced the plaster and board sheathing (CMHC, 1999). In the period from 1940 to 1980, a shift from board sheathing to panel sheathing took place resulting in better seismic performance for wood frame construction. Lumber was continued to be used as the primary framing material, but with smaller cross section. As for foundations, a shift occurred from weak masonry foundations to concrete foundations, mostly using slab-on-grade systems. Post 1980 construction was the period of using engineered wood products in structures (Kalman and Roaf, 1978; NorthVan 1993; Ventura and Kharrazi, 2003)

In 1941 the first National Building Code of Canada (NBCC) was published. However, due to the complexity of the code and the lack of expertise, a shorter and simpler version of NBCC, restricted to the small buildings, was published. In 1965, the first edition of the residential

standard was published along with a new version of NBCC in short form. In 1970, this short form was added to the NBCC as Part 9, housing and small buildings. Part 9 became a “code within a code,” and used as a rule of thumb document for small building construction without a need for an engineered design (NRCC, 1990).

To design a wood frame building, Part 4 of NBCC refers users to CSA O86, “Engineering Design in Wood.” The first edition of CSA O86 was published in 1959 (CSA, 1959). However no specific provisions for the design of shearwalls and horizontal diaphragms was considered. Specific information for lateral design first appeared in the 1989 edition of the CSA O86 standard in concert with changes to the NBCC (CSA, 1989).

In 2001, The Engineering Guide for Wood Frame Construction (CWC, 2009) was developed to deal with the design of wood frame buildings that fall under the limitations of Part 9 of the NBCC, where the prescriptive requirements of part 9 may not be adequate.

In the 2009 edition of CSA O86, new and more detailed requirements for wood diaphragms were introduced to address the revisions to the seismic provisions of the 2010 NBCC (CSA, 2009). Also, in the same year, a new version of NBCC Part 9 was published with explicit provisions for systems to resist lateral loads applicable to high seismic zones. These provisions would allow the design of robust wood structures with adequate lateral resistance without using engineered designs.

Table 2-5 summarizes the new limitations on the application of Part 9 old version (2005) and new lateral load provisions of Part 9, based on spectral accelerations at 0.2 seconds ( $S_a$  (0.2)) and high wind pressures (HWP). Three lateral load categories have been considered based on different  $S_a$  and HWP values, including: Low, High, and Extreme. The impact of this categorization across the country due to earthquake is illustrated in Figure 2-11. As the figure illustrates, 45 locations in the country are required to use the new provisions of Part 9, mostly in British Columbia. Only 3 locations in Quebec are not allowed to use the provisions of Part 9 of NBCC, and are required to use Part 4 of NBCC or the CSA O86 provisions. (NRCC, 2011; Taraschuk, 2011)

**Table 2-5: New Limitations on the Application of Part 9 of NBCC**  
(NRCC, 2011, Taraschuk, 2011)

Category	Wind	Seismic-light	Seismic-heavy	Requirement
	1 in 50 yr. hourly wind press, kPa	Spectral response acceleration	Spectral response acceleration	
Low	$HWP < 0.8$	$S_a(0.2) \leq 0.7$	$S_a(0.2) \leq 0.7$	Same as 2005 NBC
High	$0.8 \leq HWP < 1.2$	$0.7 < S_a(0.2) \leq 1.2$	$0.7 < S_a(0.2) \leq 1.1$	Requirements in new subsection 9.23.13
Extreme	$HWP \geq 1.2$	$S_a(0.2) > 1.2$	$S_a(0.2) > 1.1$	Part 4 accepted practice



**Figure 2-11: The Impact of the New Categorization, Proposed in Part 9 of NBCC 2010, Across Canada, Due to Earthquake** (NRCC, 2011; Taraschuk, 2011)

# Chapter 3

## Seismic Risk Assessment of Wood Frame Construction using Hierarchical Fuzzy Rule Base Modeling

---

### 3.1 General

In the following chapter, the methodology used to develop the seismic risk assessment tool (CanRisk) for buildings is presented, along with detailed descriptions of the assessment parameters required for evaluation.

### 3.2 Development of Hierarchical Structure for Seismic Risk Analysis of Buildings

In preliminary seismic risk assessment, it is not desirable to develop a complex mathematical formulation for screening of deficient buildings, since the procedure should be fast and efficient (Tesfamariam, 2008). The complex problem of risk assessment can be easily managed through a simple hierarchical structure as seen in Figure 3-1 and Figure 3-2. In this hierarchy, each pair of parameters are combined and evaluated using the fuzzy logic system outlined in Chapter 2. The inherent uncertainty and vagueness in a seismic risk assessment is best handled through fuzzy logic. First membership functions are established for each individual parameter and then the parameters are combined using the fuzzy rule base system created based on expert opinion. Within the hierarchy seven levels can be identified. In each level, each pair of parameters are integrated using fuzzy logic, until the level one, risk index, is achieved.

The hierarchy includes three main modules; site seismic hazard, building vulnerability (structural and non-structural), and building importance/exposure. These modules are integrated using fuzzy base modeling in order to compute the seismic risk. In the site seismic hazard module, the spectral acceleration of the building is calculated by integrating fundamental period, soil type, and site seismicity using the procedure outlined in NBCC (NRCC, 2010). This spectral acceleration is used as the indicator of site seismic hazard. The

building vulnerability module captures the inherent structural and non-structural deficiencies of a particular building type. It includes two different module types; the hierarchical structural seismic risk analysis as seen in Figure 3-1 and the hierarchical non-structural seismic risk analysis as seen in Figure 3-2. The last module is the building importance/exposure, which quantifies expected human loss, emergency response capacity and economic loss by evaluating building area, building use, occupancy type and economic impact (Elsabbagh, 2013; Tesfamariam, 2008).

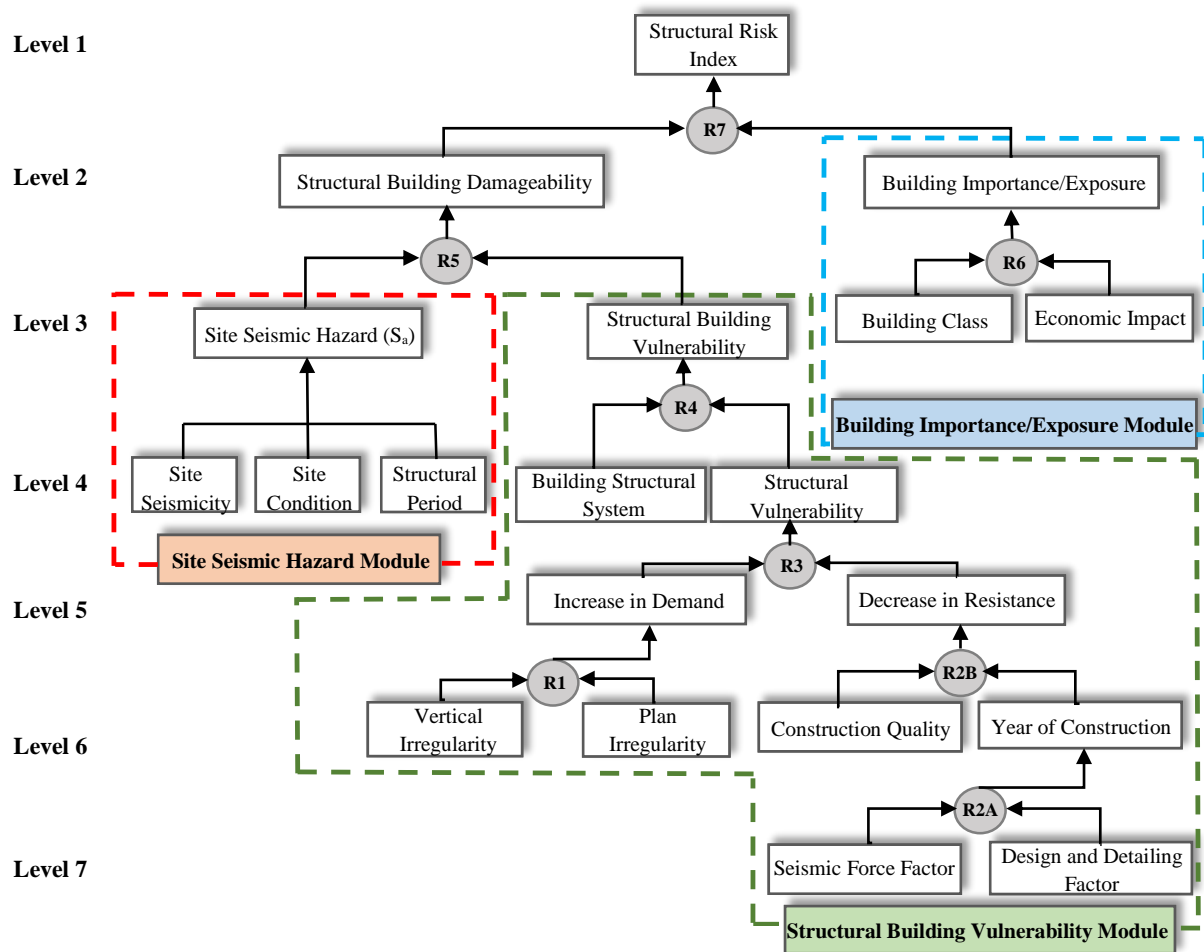

**Figure 3-1: Hierarchical Structural Seismic Risk Analysis of Buildings**  
(Elsabbagh, 2013; Tesfamariam, 2008)

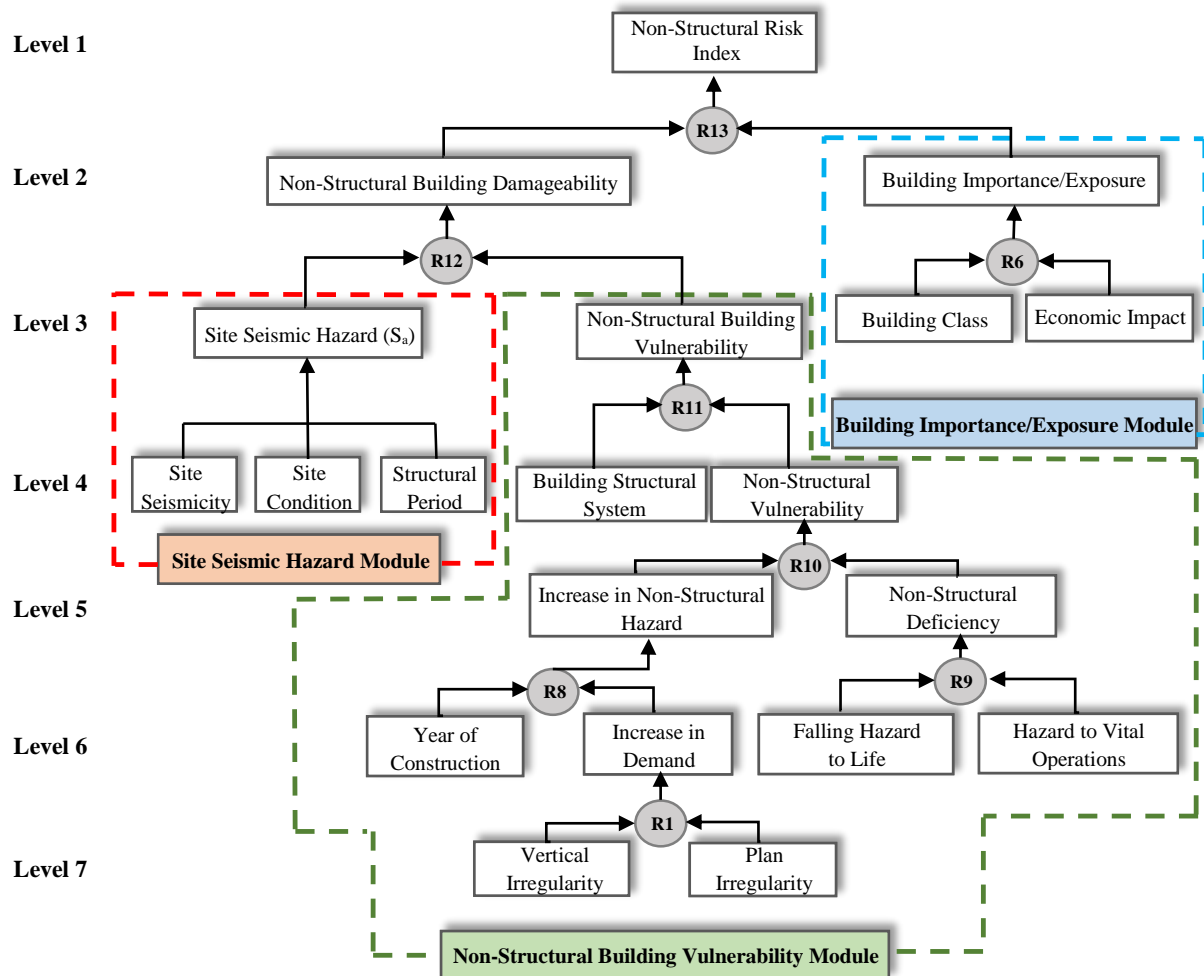

**Figure 3-2: Hierarchical Non-structural Seismic Risk Analysis of Buildings**  
(Elsabbagh, 2013; Tesfamariam, 2008)

Considering the three main modules of the hierarchy, in seven steps, the seismic risk index ( $I^R$ ), at level one of the hierarchy, is calculated as indicated below (Tesfamariam, 2008):

Step 1. Collect all the relevant information required for seismic risk assessment of a building (performance modifiers) based on the hierarchical structure.

Step 2. Use the transformation values, and transform inputs of the performance modifiers into commensurable units.

Step 3. Aggregate performance modifiers of the site seismic hazard module, to obtain the site seismic hazard index ( $I^{SSH}$ ).

Step 4. Aggregate performance modifiers of the building vulnerability module to obtain the building vulnerability index ( $I^{BV}$ ), using fuzzy rule base modeling.

Step 5. Compute the building damageability index ( $I^{BD}$ ),

Step 6. Aggregate performance modifiers of the importance/exposure module, to obtain the building importance/exposure index ( $I^{IE}$ ),

Step 7. Compute the risk index ( $I^R$ ).

The three main modules of the hierarchy and their performance modifiers are further described in the following sections.

### 3.3 Site Seismic Hazard Module ( $I^{SSH}$ )

The site seismic hazard is defined as the effect of earthquake induced ground motion on an existing building infrastructure. The ground shaking is considered as the main seismic hazard factor to cause building damage (Bird and Bommer, 2004). Three factors are aggregated to calculate the effects of ground motion on buildings, including: site seismicity, site condition, and fundamental period. The interaction of these three parameters is best described through uniform hazard spectra (UHS) defined in NBCC. National building code of Canada has outlined a procedure to formulate UHS from which the spectral acceleration is calculated for each building as an indicator of site seismic hazard (NRCC, 2010). The UHS provides a representation of earthquake effects on a given structure. It is building period dependent. The procedure of formulating UHS starts with identifying the location of the building and obtaining the corresponding seismic data (the UHS values) from NBCC. Next, the site classification (soil type), as well as, the seismic force resisting system (SFRS) of the building are identified, and the fundamental period is computed. Finally, based on the NBCC 2010 provisions, the UHS is formulated and the corresponding spectral acceleration is obtained. The resulting spectral acceleration value is then fuzzified using the fuzzy system seen in Figure 3-3. For more information about fuzzification please refer to Chapter 2.

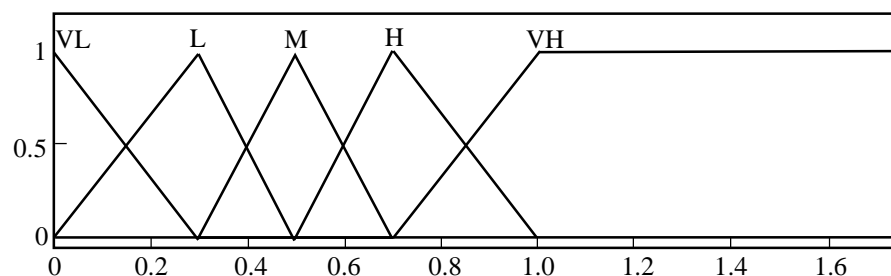

Figure 3-3: The Fuzzy System used for Site Seismic Hazard Fuzzification (Elsabbagh, 2013)

### 3.3.1 Site Seismicity

The level of seismic hazard in a specific geographical location is determined by site seismicity which is described by spectral acceleration values at periods of 0.2, 0.5, 1.0 and 2.0 seconds for a 5% damped single degree of freedom (SDOF) system. Spectral values are derived for a uniform probability of exceedance of 2% in 50 years. These four spectral values develop the Uniform Hazard Spectra (UHS) for different regions in Canada (NRCC, 2010; Atkinson, 2004). For example, Table 3-1 lists the spectral values for Toronto (representing low level of seismicity), Ottawa (moderate seismicity), and Vancouver (high seismicity), and Figure 3-4 illustrates the corresponding UHS developed for these cities. The spectral accelerations decrease linearly beyond  $T = 2.0$  sec to a value of  $Sa(2.0)/2$  at  $T = 4.0$  sec, and then remain constant beyond 4.0 sec.

**Table 3-1: NBCC-2010 Seismic Data for Toronto, Ottawa, Vancouver**

City	Sa(0.2)	Sa(0.5)	Sa(1.0)	Sa(2.0)
Toronto	0.26	0.13	0.055	0.015
Ottawa	0.66	0.32	0.13	0.044
Vancouver	0.94	0.64	0.33	0.17

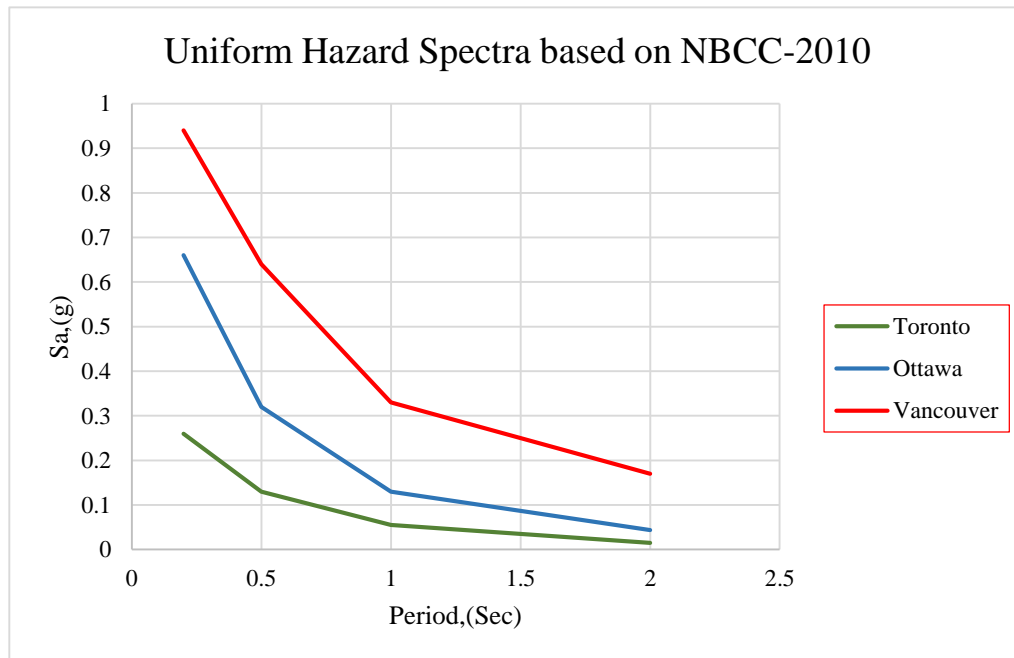

**Figure 3-4: Uniform Hazard Spectra based on NBCC-2010**

### 3.3.2 Site Condition

The soil type or site soil condition has a significant effect on the site seismic hazard. In a site, consisting of soft soil, the frequency content and the magnitude of the seismic waves is significantly higher than a site consisting of hard rock (NRCC, 2010). Therefore, the likelihood of damage during an earthquake is higher for a building located on a soft soil because of the dramatic amplification of ground motions seen on these soil types, as demonstrated in 1989 Loma Prieta Earthquake (Heidebrecht, 2003). A list of site classifications for different soil types is provided in NBCC 2010, as seen in Table 3-2. Among these site classes, Class A and B (hard rock and rock) have better seismic behaviour, creating lower amplitude in ground motion intensity, compared to Class D and E (stiff soil and soft soil), where seismic waves amplify, increasing the site seismic hazard.

**Table 3-2: NBCC-2010 Site Classification**

Site Class	Soil Profile Name	Soil Shear Wave Average Velocity ( $V_s$ )
A	Hard Rock	$V_s > 1500$
B	Rock	$750 < V_s \leq 1500$
C	Very dense soil and soft rock	$360 < V_s < 760$
D	Stiff Soil	$180 < V_s < 360$
E	Soft Soil	$V_s < 180$

### 3.3.3 Fundamental Period of Vibration

Determination of the spectral response acceleration  $S_a(T_1)$ , and consequently site seismic hazard, requires an estimate of the fundamental period ( $T_1$ ) of the structure. The NBCC provides different approximate empirical formulas to calculate the fundamental period, depending on the lateral load resisting system listed in Table 3-3. The fundamental period may be determined using more accurate methods of engineering mechanics, including the Rayleigh method, but the value calculated in this method must not exceed an upper limit determined by NBCC, to avoid the underestimation of seismic design forces. A simple indicator of the fundamental period can be the number of stories, where the buildings with less stories have lower periods and consequently have higher spectral accelerations. The fundamental period calculated in this step is then used to calculate the spectral acceleration  $S_a(T_1)$  of the building

corresponding to the period. This  $S_a(T_1)$  value is used as a transformation value in the fuzzy system to indicate the level of site seismic hazard.

**Table 3-3: Empirical Formulas for Building Period defined in NBCC-2010 (NRCC, 2010)**

<b>Seismic Force Resisting System (SFRS)</b>	<b>Fundamental Lateral Period (<math>T_1</math>)</b>
Steel Moment Frames	$0.085(h_n)^{3/4}$
Concrete Moment Frames	$0.075(h_n)^{3/4}$
Other Moment Frames	0.1N
Braced Frames	$0.025h_n$
Shear Wall and other structures	$0.05(h_n)^{3/4}$
$T_1$ (seconds), $h_n$ (meters), N (Number of stories)	

### 3.4 Building Vulnerability Module ( $I^{BV}$ )

The inherent structural and non-structural deficiencies of a particular building type are captured by the building vulnerability module (seen as level 3 in Figure 3-1 and Figure 3-2). There are two main vulnerability categories considered in this module; structural building vulnerability (SBV) and non-structural building vulnerability (NSBV) shown as level 4 in Figure 3-1 and Figure 3-2 respectively. In the structural vulnerability, the performance modifiers effecting the seismic performance of structural elements is considered, while in the non-structural vulnerability, the performance of all other components of the building, which are not structural in nature but can be damaged by earthquake effects, are considered (NIBS,2010; Elsabbagh, 2013). In addition, the type of seismic force resisting system of the building is another key factor affecting its seismic vulnerability, as shown in level 4 of the hierarchy. The parameters of the hierarchical structure of these vulnerability categories are aggregated to compute the structural building vulnerability index ( $I_S^{BV}$ ) and the non-structural building vulnerability index ( $I_{NS}^{BV}$ ) (Tsfamariam, 2008; Elsabbagh, 2013). These parameters are further described below.

#### 3.4.1 Structural Vulnerability (SV)

The structural vulnerability captures inherent seismic deficiencies in the structure. The poor performance of buildings in the past earthquakes has demonstrated the potential causes of failures associated with these deficiencies, such as irregular building configurations, or

insufficient seismic design and detailing requirements (Saatcioglu et al. 2001, Tesfamariam, 2008). They can be grouped into two categories; factors contributing to an increase in seismic demand, including vertical irregularity and plan irregularity, and factors contributing to reduced ductility and energy absorption capacity, including construction quality and year of construction. The information related to these factors can be estimated from a walk-down survey or engineering drawings, if available (Saatcioglu et al. 2001; Tesfamariam, 2008).

#### **3.4.1.1 Increase in Demand (ID)**

The increase in seismic demand of a building is caused by any type of irregularity in building configuration. Building irregularities increase seismic demands in critical elements of the building, such as a particular set of beams, columns, or walls, and create damage in those elements, potentially affecting the whole building (EERI, 2006; NIBS, 2006). The 2005 NBCC was the first edition of NBCC which provided detailed assessment of irregularities, and introduced eight types of irregularities. These irregularity types are those that were observed to cause structural damage during past earthquakes. Limitations were introduced concerning analysis and design of these types of buildings, such as the limitations on the use of static analysis procedure, restrictions on types of irregularities permitted for different seismic regions and different building use, such as post-disaster buildings (NRCC, 2005; Heidebrecht, 2003). These irregularities can be grouped under two categories; vertical irregularity and plan irregularity.

##### ***3.4.1.1.1 Vertical Irregularity (VI)***

Discontinuity in the lateral load resisting system (e.g. a shearwall) and abrupt changes in strength and stiffness along the building height, which usually concentrate damage to a single story of a multistory building, is called vertical irregularity. Examples of vertical irregularity include buildings with setbacks, hillside buildings, and buildings with soft stories (EERI, 2006; NIBS, 2006). As mentioned in Chapter 2, the most common vertical irregularity in wood frame construction, observed to cause damage during most of the previous earthquakes, especially 1989 Loma Prieta and 1994 Northridge earthquakes, is soft story caused by tuck-under parking (Graf, 2008; Rainer and Karacabeyli, 2000). Different types of irregularities may have different levels of importance in terms of their effects on building seismic behaviour. Also, depending on the severity of a particular irregularity, its influence on structural response may

vary. For example, while too much torsional irregularity in a building is a serious plan irregularity, in a lesser form it may have little effect on seismic performance (EERI, 2006). For the seismic risk assessment procedure developed in the current research project, the severity of a vertical irregularity in a building is left to the judgment of the assessor. Typically, in a walk-down survey, the level of vertical irregularity can be determined using the linguistic terms listed in Table 3-4. The transformation values considered for each one of these linguistic terms, used for fuzzification purposes, is illustrated in Table 3-4 (Elsabbagh 2013).

**Table 3-4: Linguistic Input Parameters and Transformation Values for VI** (Elsabbagh, 2013)

<b>Linguistic Input</b>	<b>Transformation Value</b>
“Very Low”	0.1
“Low”	0.3
“Moderate”	0.5
“High”	0.7
“Very High”	0.9

#### **3.4.1.1.2 Plan Irregularity (PI)**

Non-uniform mass and/or shearwall distribution that create torsional forces in a building, and re-entrant corners caused by irregular plan configuration (buildings with plan forms such as L or T), are examples of plan irregularities which result in the concentration of earthquake forces and deformations in a particular part of the building plan (ERRI, 2006, NIBS,2006). As in the case of vertical irregularity, the severity of the plan irregularity is also left to the judgment of the assessor. In a walk-down survey, the level of plan irregularity can be determined using the linguistic terms listed in Table 3-5. The table also includes the transformation values for fuzzification purposes (Elsabbagh 2013).

**Table 3-5: Linguistic Input Parameters and Transformation Values for PI** (Elsabbagh, 2013)

<b>Linguistic Input</b>	<b>Transformation Value</b>
“Very Low”	0.1
“Low”	0.3
“Moderate”	0.5
“High”	0.7
“Very High”	0.9

### 3.4.1.2 Decrease in Resistance (DR)

Reduction in ductility and energy absorption in a building, due to poor construction practices and/or lack of appropriate seismic design and detailing, causes decrease in seismic resistance of a building (Saatcioglu et al, 2001; Mitchell et al., 2005). For example, poor design and detailing requirements or construction practices such as inadequate sill plate anchorage to the foundation, mostly seen in light wood frame buildings built before 1940, causes the buildings to slide off the foundation and get damaged during an earthquake (Graf, 2008). Two performance modifiers are considered in computing the decrease in resistance; i) the construction quality and ii) the year of construction (Tesfamariam, 2008).

#### 3.4.1.2.1 Construction Quality (CQ)

One of the important factors affecting the response of a building to seismic events is construction quality, requiring good materials and workmanship. Even in older buildings, which are considered more vulnerable, good quality of materials and construction can improve their seismic performance (Bruneau and Lamontagne 1994, Coburn and Spence 2002). Common errors in wood frame construction, causing reduction of construction quality, are outlined in Chapter 2. To determine the construction quality of a building, a site visit is required and it can be qualitatively evaluated as defined in Table 3-6 (Tesfamariam, 2008).

**Table 3-6: Linguistic Input Parameters and Transformation Values for CQ** (Tesfamariam, 2008)

Linguistic Input	Transformation Value
“Good”	0.1
“Average”	0.5
“Poor”	0.9

#### 3.4.1.2.2 Year of Construction (YOC)

The seismic vulnerability of buildings varies with the year of construction. The year of construction provides important information about the seismic design provisions employed and the level of detailing and building regulations that were followed in design and construction, relevant to the timeframe at which the building was constructed. Having this information, the level of strength, stiffness, ductility and detailing in the structure can be estimated (Tesfamariam, 2008). Therefore, the evolution of seismic design provisions and common practice over the last century is very important in order to determine the seismic

vulnerability of a building. In Canada, year of construction considers historical development of the NBCC, CSA, as well as common design practices used for a structural system as they pertain seismic design. Two factors are reflected in year of construction; i) Seismic Force Factor, and ii) Design and Detailing Factor (Elsabbagh, 2013).

#### 3.4.1.2.2.1 Seismic Force Factor (SFF)

Over the years, major changes have been introduced to the seismic provisions of the NBCC in terms of the level of design forces. The comparison of the seismic force levels of the current building code determined using the equivalent static load procedure, to those found in the earlier edition of NBCC, provides a quantitative measure for how the seismic forces have been evaluated throughout the years and how the level of design forces has affected seismic vulnerability of buildings. Figure 3-5 illustrates the historical development of the base shear equation in the NBCC (Mitchell et al., 2010). Equation [3-1] compares the level of seismic design forces determined using the current equivalent static procedure, to those found in the earlier editions of NBCC shown in Figure 3-5 (Elsabbagh,2013). The ratio of the seismic design forces in the equation is then multiplied by the spectral acceleration of the building at reference soil Class C according to NBCC 2010 to reflect the influence of the level of seismicity in the region. This is necessary because any difference in seismic force levels resulting from year of construction in a low seismic region where wind governs the design is likely to have much less effect on seismic performance of the building than a similar difference in seismic forces in a high seismic zone. (Elsabbagh, 2013). In non-engineered wood frame construction, the effect of Seismic Force Factor is not considered in the building vulnerability evaluation, since these buildings are not designed using seismic design loads.

$$SFF = \frac{V_{2005}}{V_{Previous}} * S_a^c(T_1) = \frac{S_a^c(T_1) M_V}{V_{Previous}} * S_a^c(T_1) \quad [3-1]$$

Where:

- *SFF* is the Seismic Force Factor
- *V<sub>Previous</sub>* is the elastic base shear equation from Figure 3-5 for the YOC selected when reference soil conditions are used for a regular building with importance factor of 1.0.
- *S<sub>a</sub><sup>c</sup>(T<sub>1</sub>)* is the building's spectral acceleration at reference soil class C according to NBCC-2005.

- $M_V$  is the higher mode effect factor according to NBCC-2005

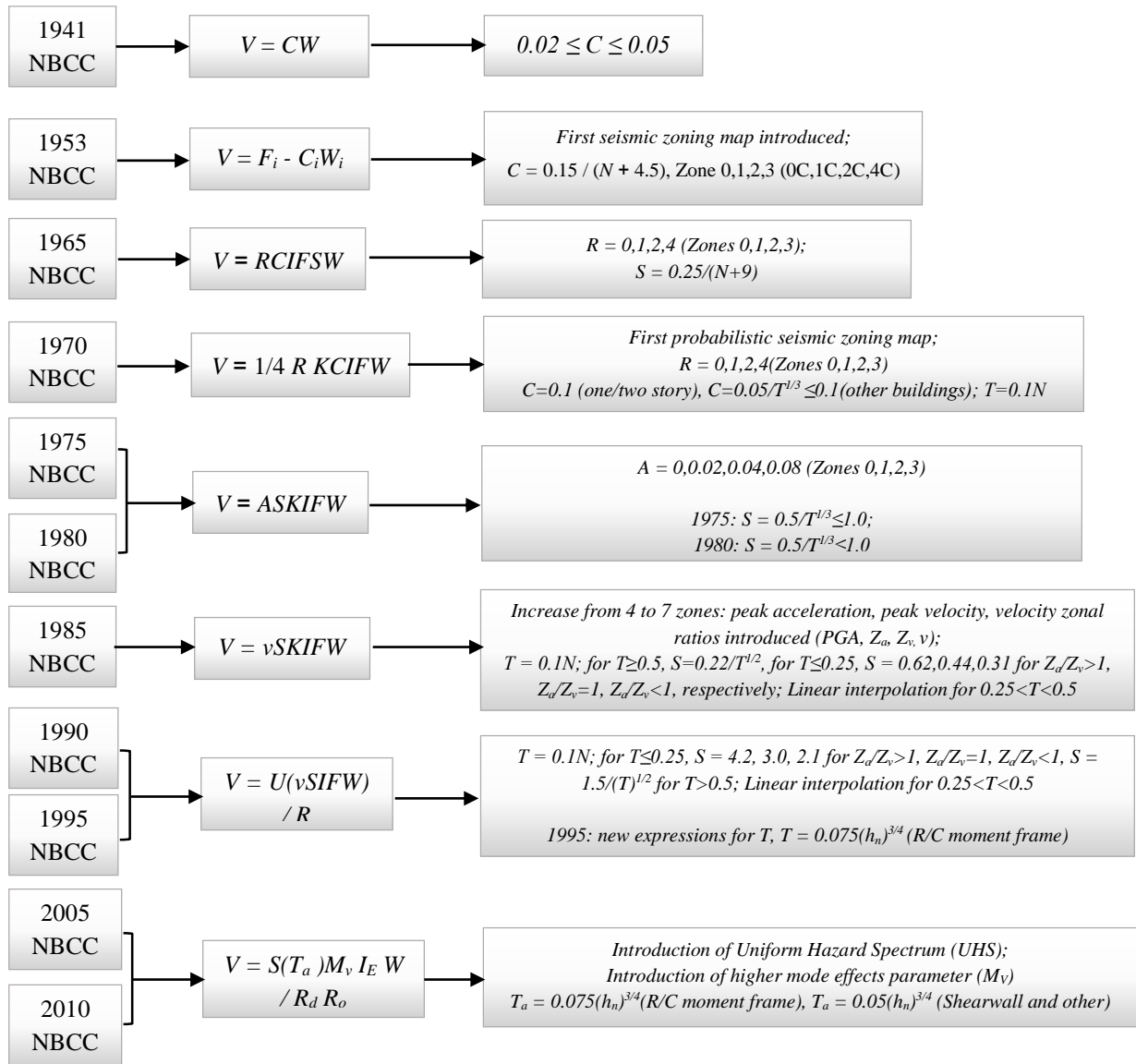

Figure 3-5: Historical Development of Base Shear Equation of the NBCC (Mitchell et al., 2010)

In Equation 3-1,  $M_V$  is a factor that accounts for higher mode effects on base shear. In the 1995 edition of the NBCC, the higher mode effects on the distribution of lateral forces were accounted for by adding a top force at the roof level and by reducing the overturning moment by a factor, which is also used in the NBCC 2005 provisions. However, earlier codes accounted for force amplification associated with higher mode effects by empirically raising the design spectra in the high period range, but, in the 2005 edition of NBCC, this is done through a higher mode factor ( $M_V$ ) (NRCC, 2005).

The ratio of elastic base shear values computed on the basis of post-2005 NBCC and earlier editions of the code can result in very high values, especially for buildings designed prior to 1970s because earlier codes may have required substantially lower forces than the levels currently used. This would skew the influence of year of construction on building vulnerability as affected by design force levels, especially if the building design is governed by other forces, rather than those caused by earthquakes. Therefore, upper limits are placed to this ratio (cut-off values) as indicated in Table 3-7 based on the maximum UHS specified in the 2005-NBCC. This is consistent with the approach used in Table 4.1.8.9 of the 2005-NBCC in assigning other design restrictions based on regional seismicity (Elsabbagh, 2003).

**Table 3-7: Cut-off values for the ratio of NBCC-2005 base shear to previous year base shear equations**  
(Elsabbagh, 2013)

Range	Value of $S_a(0.2)$			
	< 0.2	$\geq 0.2$ to < 0.35	$\geq 0.35$ to $\leq 0.75$	> 0.75
<b>Cut-off Value</b> $\left(\frac{V_{2005}}{V_{Previous}}\right)$	1	2	3	4

#### 3.4.1.2.2.2 Design and Detailing Factor (DDF)

For a long time, the NBCC seismic provisions have recognized that seismic forces are reduced when a structure has ductile behaviour and enters into the inelastic range of deformations (Heidebrecht, 2003). Therefore, force modification factors were introduced to reduce design force levels for ductile buildings. Introduction of force modification factors in the NBCC, corresponding improvements in the design and detailing provisions outlined in relevant CSA standards for different materials, and the developments in common construction practices provide a good indication of the level of ductility estimated in a specific structural system as reflected by year of construction (Elsabbagh, 2013). As has been observed during previous earthquake reconnaissance surveys, wood frame buildings of recent years have more ductile behaviour than those built before 1940s when no code requirements existed for design and construction detailing. The key dates in the development of NBCC and CSA for engineered wood frame construction and the corresponding proposed transformation values are shown in Table 3-8. Similarly, transformation values for non-engineered wood frame construction are illustrated in Table 3-9.

**Table 3-8: Transformation Values and Breaking Years for the Computation of the DDF for Engineered Wood Framed Buildings**

Year	Key Findings Affecting Code Developments	Transformation Value
1940-1959	Older (usually pre-1940) houses are often not bolted to their foundation which causes the building to slide off the foundation during an earthquake (Graf, 2008).	<b>3.5 ( Pre-1940)</b> <b>3.0 ( Post-1940)</b>
	In 1941 the first National Building Code of Canada (NBCC) was published	
1959-1990	First Edition of CSA O86, Engineering Design in Wood, was published in 1959	<b>2.0</b>
	Introduction of K factors in NBCC 1970, representing type of construction, damping, ductility, and energy absorption.	
	Homes and most buildings constructed in Canada since the early 1970s have been required to meet the seismic safety requirements in the building code. (Kovacs, 2010)	
1990-2010	Specific information for lateral design, including the design of shearwalls and horizontal diaphragms, first appeared in the 1989 edition of the CSA O86 standard in concert with changes to the NBCC.	<b>1.0</b>
	Changes to the NBCC including the replacement of the K factor by the force modification factor, R	
	The 2005 NBCC first listed eight types of irregularities, causing structural damage in the past earthquakes, and specified some limitations concerning analysis and design for each of those types	
Post-2010	Addition of new clause, seismic design consideration for shearwalls and diaphragms to CSA O86- 2009, based on seismic performance of wood frame structures during past earthquakes and full size shake tables	<b>0.5</b>

**Table 3-9: Transformation Values and Breaking Years for the Computation of the DDF for Non-Engineered Wood Framed Buildings**

<b>Year</b>	<b>Comments on the Breaking Years</b>	<b>Transformation Value</b>
1940-1965	Older (usually pre-1940) houses are often not bolted to their foundation which causes the building to slide off the foundation during an earthquake (Graf, 2008).	<b>4.0 (Pre-1940) 3.5 ( Post-1940)</b>
1965-1990	First edition of the Residential Standards, supplement to the National Building Code of Canada, was published in 1965 In 1970 NBCC, Part 9 became a “code within a code”, without referring to Residential Standards, as a rule of thumb document used for small building construction without a need for an engineer design.	<b>2.5</b>
1990-2010	Based on FEMA Report Series on Seismic Safety of Existing Buildings, 1990 is a Benchmark year in wood frame construction. wood framed structures, built after this year have a better seismic behavior	<b>1.5</b>
Post-2010	Significant changes occurred in Part 9 of NBCC 2010 including addition of new requirements for seismic resistance of conventional wood frame construction	<b>0.5</b>

The transformation values for design and detailing factor (DDF) are multiplied by the maximum UHS specified in the 2005-NBCC for reference soil type C to reflect the significance of design codes and practices in regions of different seismicity, as also done earlier for SFF. This is illustrated in Equation 3-2.

$$DDF = Transformation\ Value * S_a^c(T_1) \quad [3-2]$$

Where:

- *DDF* is the Design and Detailing Factor
- *Transformation Value* as depicted by Table 3-10 and Table
- $S_a^c(T_1)$  is the building’s spectral acceleration at reference soil class C.

### **3.4.2 Non-Structural Vulnerability**

The majority of earthquake damage in recent North American earthquakes was caused by non-structural failures, with significant costly consequences. The failures of nonstructural components may cause injuries and fatalities, expensive property damage to buildings and their contents, and force the closure of residential, medical and manufacturing facilities (ATC, 2011). Therefore, it is necessary to evaluate non-structural elements in seismic risk assessment of a building. Nonstructural components of a building are those components which are not part of the structural system, including: architectural components (such as partitions, ceilings, veneers, and chimney), mechanical, electrical, and plumbing components (such as pumps, chillers, fans, and piping), and furniture, fixtures & equipment, and contents (such as shelving and book cases) (ATC, 2011). Non-structural vulnerability can be classified in two categories: i) falling hazards to life ii) hazards to vital operations (damage to vital operations of strategic facilities), which have been adopted from the Seismic Screening of Buildings in Canada tool (Saatcioglu et al., 2011).

#### **3.4.2.1 Falling Hazards to Life (FHL)**

Falling hazards to life (FHL) refers to non-structural components of a building which could get damaged and fall during an earthquake, posing hazard to passers-by or to people inside the building. Also, damaged non-structural components can block safe exits in a building and endanger the life safety of the people inside (ATC, 2011, Saatcioglu et al., 2011). Examples of potentially hazardous nonstructural damage that have occurred during past earthquakes includes collapsed unreinforced masonry chimneys and stone or masonry veneer common in wood frame construction, masonry parapets, heavy interior walls, heavy ceilings, and overturned heavy furniture (ATC, 2011). Figure 3-6 shows damage to the non-structural components of a building during the 1994 Northridge Earthquake creating falling hazard to life. The level of falling hazards to life is left to the judgment of the assessor. Therefore, in a walk-down survey, the falling hazard to life is determined using the grades listed in Table 3-10 (Elsabbagh, 2013).



**Figure 3-6: Failure of office partitions, ceilings, and light fixtures in the 1994 Northridge Earthquake (FEMA 74, 1994)**

**Table 3-10: Linguistic Input Parameters and Transformation Values for FHL**

<b>Linguistic</b>	<b>Transformation value</b>
“Very Low”	0.1
“Low”	0.3
“Moderate”	0.5
“High”	0.7
“Very High”	0.9

### **3.4.2.2 Hazards to Vital Operations**

Hazards to Vital Operations (HVO) refer to the damage that may occur in non-structural components of a special or post disaster building, such as a hospital, effecting its functionality and overall operational requirements. Examples of damage to vital operations are; damage to equipment needed for functionality such as HVAC systems and elevators, or damage to communications and computer equipment in a fire or police station or a hospital (ATC, 2011). The hazards to vital operations are determined using the grades listed in Table 3-11 (Elsabbagh, 2013).

**Table 3-11: Linguistic Input Parameters and Transformation Values for HVO**

<b>Linguistic</b>	<b>Transformation value</b>
“Very Low”	0.1
“Low”	0.3
“Moderate”	0.5
“High”	0.7
“Very High”	0.9

### **3.4.2.3 Increase in Non-Structural Hazard**

To determine the severity of non-structural vulnerability in a building, in addition to the aforementioned hazards, two factors are effective; the year of construction and the level of increase in seismic demand (Saatcioglu et al., 2011). Higher seismic demands on a building result in increased vulnerability of non-structural components. Also, in term of the year of construction, it was the 1970 edition of NBCC in which the horizontal force factors were considered in the design of non-structural components for lateral forces (NRCC, 1970) for the first time. This was an improvement compared to the minimal restrictions considered in the earlier codes for design of non-structural components (NRCC, 1965). Therefore, increase in non-structural hazard in a building depends on building’s year of construction and its level of increase in seismic demands (Saatcioglu et al., 2011).

### **3.4.3 Building Structural System**

The type of lateral load resisting system plays a major role in building’s resistance to seismic forces. The seismic performance of different types of structural systems in historical earthquakes has highlighted significant differences in the performance of various lateral load resisting systems. For example, modern single-story wood-framed buildings have performed well in major earthquakes from a life-safety perspective; most of the occupants survived the earthquake shakings with minor damage, showing that damage control perspective was also largely achieved (Rainer and Karacabeyli, 2000; NIBS, 2006)

As mentioned in Chapter 2, wood frame construction is divided into two main categories, heavy timber and light frame. In light wood frame buildings, the shearwalls consist of wall studs, sheathed with wood structural panels, wood based wallboards, or gypsum wallboard,

using nail or screw connectors. The behaviour of light frame shearwalls is complex and influenced by many factors, but the primary factor is the type of sheathing and connector used to attach the sheathing to the wall studs. This produces shearwalls that vary in behaviour from strong, stiff walls with little energy dissipating capabilities, to relatively weaker, more flexible walls with good energy dissipating capabilities. In Table 3-12, reproduced from FEMA 273 (ATC, 1997), different types of sheathing products, common in light wood frame construction, and their expected seismic behaviour are listed.

**Table 3-12: Types of Sheathing and their Expected Seismic Behaviour**

<b>Sheathing Product</b>	<b>Seismic Performance</b>
Wood Structural Panels (Plywood or OSB)	Of the acceptable shearwall sheathing products, wood structural panels (Plywood or OSB) are known to perform better than others in a seismic event (NIBS, 2006).
Diagonal lumber	Diagonal lumber sheathed shearwalls are stiffer and stronger than horizontal lumber sheathed shearwalls. They also provide greater stiffness for deflection control, and thereby greater damage control.
Horizontal lumber	Horizontal lumber sheathed shearwalls are weak and very flexible and have long periods of vibration. These shearwalls are suitable only where earthquake shear loads are low and deflection control is not required.
Particle Board and Fiber Board	Fiberboard sheathing is very weak, lacks stiffness, and is not able to resist lateral loads. Particleboard comes in two varieties: one is similar to structural panels, the other (nonstructural) is slightly stronger than gypsum board but more brittle. Fiberboard sheathing is not suitable for resisting lateral loads, and nonstructural particleboard should only be used to resist very low earthquake loads.

Gypsum Wallboard	Gypsum wallboard has a very low lateral-force resistance capacity, but is relatively stiff until cracking occurs. These shearwalls are suitable only where earthquake shear loads are very low.
Stucco	Stucco is brittle and the lateral-force-resistance capacity of stucco shearwalls is low. However, the walls are stiff until cracking occurs. These shear walls are suitable only where earthquake shear loads are low.

Heavy timber structures are also expected to have good performance in a seismic event provided that the frames are adequately braced. If the walls in this type of buildings are not sufficiently braced to resist lateral loads, they may deform excessively and create significant damage. Even the addition of diagonal members between columns and beams (knee bracing), which is used in the traditional timber frames, creates moment-resisting joints to resist lateral loads. Therefore, bracing in heavy timber construction plays a vital role in the level of building seismic vulnerability (NRCC, 1993). The types of wood frame structural systems incorporated into the CanRisk program and the transformation values selected based on the typology of wood frame construction are introduced in Table 3-13. The transformation values selected for heavy timber structures are mainly influenced by the type of bracing used in the structure to resist the lateral loads. For light-frame structures, the transformation values are selected based mainly on the type of sheathing product used in the shearwalls and whether building is engineered or non-engineered.

**Table 3-13: Transformation Values for different types of Wood Frame Construction**

<b>Structural System</b>		<b>Transformation Value</b>
<b>Heavy Timber</b>		-
Post and Beam frame with Shear wall		0.1
Post and Beam frame with Diagonal Bracing		0.2
Post and Beam with Moment Resistant frame		0.2
Post and Beam		0.8
Traditional Timber Frame		0.5
Traditional Timber Frame with Shear wall		0.1
Cross Laminated Timber (CLT)		0.1
<b>Light Frame</b>		-
Engineered	Sheathed only with Wood Structural Panel (OSB or Plywood)	0.1
	Sheathed with Diagonal Lumber	0.2
	Sheathed with Wood Based Wallboard (Particleboard, Hardboard)	0.4
	Sheathed with Gypsum Wallboard + WSP	0.2
	Sheathed only with Gypsum Wallboard or Stucco	0.6
	Details not available*	0.6
Non-Engineered	Sheathed only with Wood Structural Panel (OSB or Plywood)	0.2
	Sheathed with Diagonal Lumber	0.3
	Sheathed with Wood Based Wallboard (Particleboard, Hardboard)	0.5
	Other Wood Based products (Shiplaps, Horizontal Lumber, Fiberboard)	0.8
	Sheathed with Gypsum Wallboard + WSP	0.3
	Sheathed only with Gypsum Wallboard or Stucco	0.7
	Details not available*	0.8
Not specified	If built after 1965 and passes the limits of number of stories (3 Story) and area (600 m <sup>2</sup> ) it will be considered Engineered	-
	If built after 1965 and does not pass the limits of number of stories and area it will be considered Non-Engineered, but conventional light frame (based on Part 9)	-
	If built before 1965 it will be considered Non-Engineered	-

\* In a case that the assessor is not able to identify the sheathing product, the worst sheathing, in terms of seismic behaviour is considered.

### 3.5 Building Importance/Exposure Module ( $I_E$ )

The building importance/exposure index ( $I_E$ ) is computed by integrating building use, occupancy, area and economic impact. This value is used to quantify the expected casualties, emergency response capacity and economic loss in an earthquake (Tesfamariam, 2008). In the NBCC, when calculating the base shear, an importance factor ( $I_E$ ) is considered for buildings, based on their occupancy class, including; normal, high, and post disaster importance classification, as seen in Table 3-14. High importance structures include schools and community centers that are able to house a large number of individuals. Post-disaster buildings include hospitals and emergency response facilities that are required to remain operational in the event of a disaster. Normal importance buildings include all other buildings that do not fall in high or post-disaster categories (NRCC, 2010).

**Table 3-14: Building Importance Categories as defined in NBCC-2010**

<b>Building Importance</b>	<b><math>I_E</math></b>
Normal	1
High	1.3
Post-Disaster	1.5

Equation 3-3 is used to compute the building class (Building Importance Factor), seen in Level 3 of the hierarchy, which is a function of occupied building area, occupancy class (Table 3-13), occupancy density, and duration (Elsabbagh, 2013). The formula has been adopted and modified from the Seismic Screening Tool (Saatcioglu et al., 2011, Elsabbagh, 2013).

[3-3]

$$BIF = Occupied\ Area * Occupancy\ Density * \frac{Average\ Weekly\ Hours}{100} * I_E$$

Where:

- *BIF* is the Building Importance Factor
- *Occupied Area* is the building's area in  $m^2$
- *Occupancy Density* is the estimated average number of people occupied per  $m^2$
- *Average Weekly Hours* is the average number of hours weekly occupied in the building

- $I_E$  is the building importance factor as defined in NBCC-2010 (NRC, 2010)

The financial considerations are also critical in evaluating building's importance. For example, in Northridge Earthquake, while the fatality was very low, the economic losses were very significant (Tesfamariam 2008, FEMA-249, 1994). In CanRisk program, the economic impact of building is categorized into negligible, average, and significant as seen in Table 3-15 (Tesfamariam, 2008).

**Table 3-15: Linguistic Input Parameters and Transformation Values for Economic Impact**  
(Tesfamariam, 2008)

Level of Economic Impact	Transformation Value
Negligible	0.1
Average	0.5
Significant	0.9

### 3.6 Building Damageability Index ( $I^{BD}$ )

The building damageability index is calculated by integrating the site seismic hazard index and the building's vulnerability index. It indicates the expected level of structural and non-structural damage in a building during an earthquake event (Tesfamariam, 2008). The structural building damageability index ( $I_S^{BD}$ ) and the non-structural building damageability index ( $I_{NS}^{BD}$ ) are represented at Level 2 in Figures 3-6, and 3-7, respectively. The ATC-13 classifies damage into 7 distinct states as seen in Table 3-15. However, in CanRisk program the damage states "none" and "slight" are combined as "none"; and "major" and "destroyed" are combined as "At/Near Collapse". Consequently, the damageability levels of CanRisk, have 5 levels of gradation as shown in Table 3-16 (Elsabbagh, 2013).

**Table 3-16: Comparison of Building Damage States of ATC-13 and CanRisk (Elsabbagh, 2013)**

Damage State (ATC-13)	Damage Range Factor (%)	Damageability Level (CanRisk)	Damageability Index Range ( $I^{BD}$ )	Description
None	0	None	0.0 – 0.2	No damage.
Slight	0-1			Limited localized minor not requiring repair.
Light	1-10	Light	0.2 – 0.4	Significant localized damage of some components generally not requiring repair.
Moderate	10-30	Moderate	0.4 – 0.6	Significant localized damage of many components warranting repair.
Heavy	30-60	Heavy	0.6 – 0.8	Extensive damage requiring major repairs.
Major	60-100	At/Near Collapse	0.8 – 1.0	Major widespread damage that may result in the facility being razed, demolished, or repaired.
Destroyed	100			Total destruction of the majority of the

### 3.7 Risk Index ( $I^R$ )

The risk index ( $I^R$ ), which is the final step in the hierarchical evaluation, is calculated by aggregating the building damageability index ( $I^{BD}$ ) and importance and exposure index ( $I^{IE}$ ). In this level, (Level 1 in Figures 3-1 and 3-2), the structural risk index ( $I_S^R$ ) and non-structural risk index ( $I_{NS}^R$ ) of a given building is calculated. By combining the structural and non-structural risk for the evaluated building, the overall risk index ( $I_{ALL}^R$ ) is calculated. In the CanRisk software four levels of gradation is considered for seismic risk of a given building as seen in Table 3-17 along with their corresponding level of indices (Elsabbagh, 2013).

**Table 3-17: CanRisk Risk Level and Risk Index Range** (Elsabbagh, 2013)

Risk Level	Risk Index Range ( $I^R$ )
Negligible	0.0 – 0.2
Marginal	0.2 – 0.4
Critical	0.4 – 0.6
Catastrophic Consequences	0.6 – 1.0

### 3.8 Fuzzification Summary

In the fuzzification process of each individual performance modifiers of the hierarchy, five different types of fuzzy systems have been developed based on expert opinion, and also based on the aforementioned information about these performance modifiers. The fuzzy system of the site seismic hazard module (SSH) is already illustrated in Figure 3-3. The fuzzy systems and their corresponding triangular fuzzy numbers (TFN) or trapezoidal fuzzy numbers (TPFN) of the other parameters, are illustrated in Figure 3-7 to Figure 3-10, along with a summary of the fuzzification process of the hierarchical parameters in Table 3-18 (Elsabbagh, 2013).

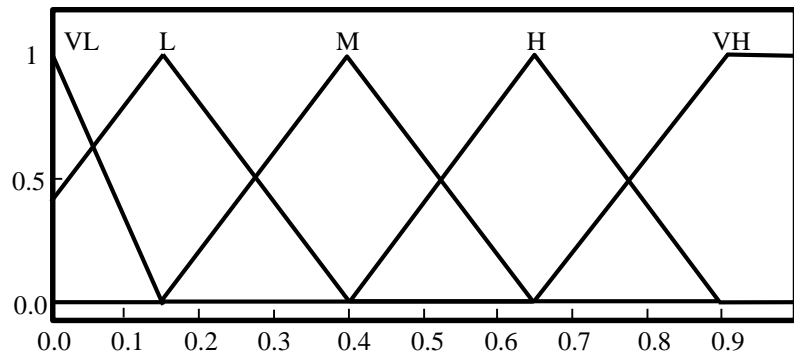

**Figure 3-7: Membership Functions and Fuzzy Sets of the Variables with TFN Values of [TFN(-0.25,0,0.15); TFN(-0.1,0.15,0.4); TFN(0.15,0.4,0.65); TFN(0.4,0.65,0.9); TFN(0.65,0.9,100)]**

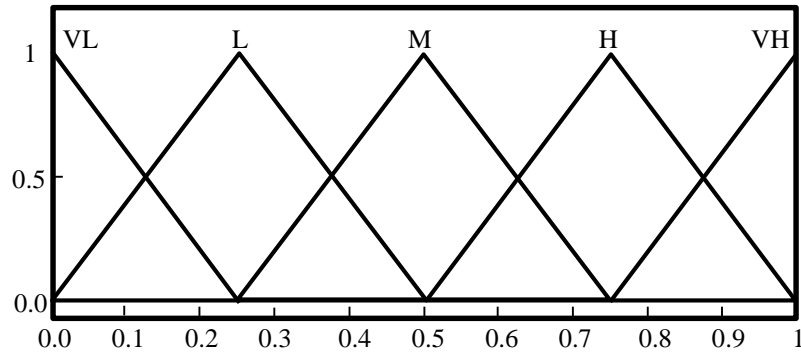

**Figure 3-8: Membership Functions and Fuzzy Sets of the Variables with TFN Values of [TFN(-0.25,0,0.25); TFN(0,0.25,0.5); TFN(0.25,0.5,0.75); TFN(0.5,0.75,1.0); TFN(0.75,1,1.25)]**

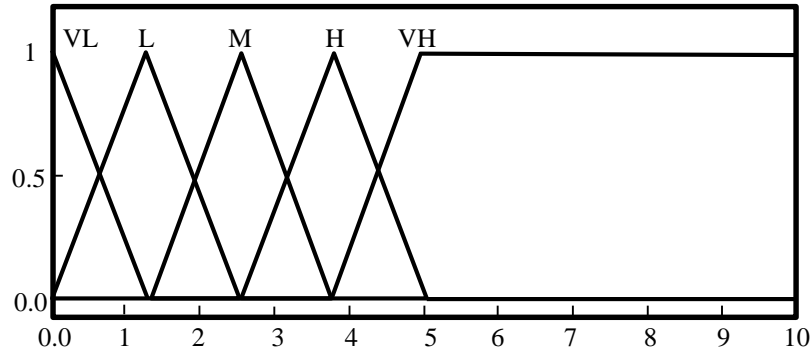

**Figure 3-9: Membership Functions and Fuzzy Sets of the Variables with TFN Values of [TFN(0,0,1.25); TFN(0,1.25,2.5); TFN(1.25,2.5,3.75); TFN(2.5,3.75,5); TFN(3.75,5,1000)]**

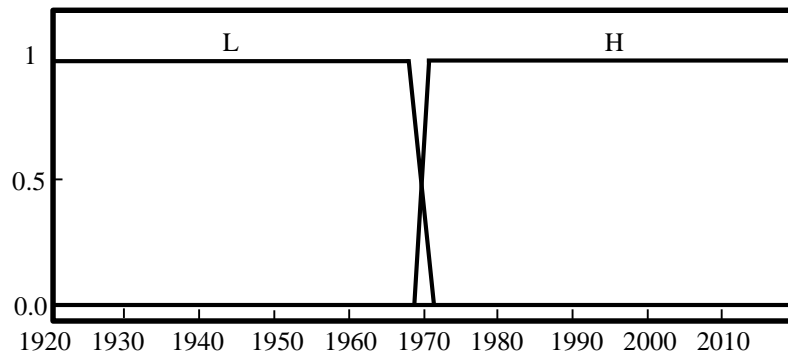

**Figure 3-10: Membership Functions and Fuzzy Sets of the YOC Variable with TPFN Values of [[TPFN (1910,1920,1969,1971); TPFN(1969,1971,2010,2010)]]**

**Table 3-18: Summary of Fuzzification of Hierarchical Structures** (Elsabbagh, 2013)

Input	Transformation	Fuzzification	FRB	Output
VI	{VL, L, M, H, VH} {0.1, 0.3, 0.5, 0.7, 0.9}	VL, L, M, H, VH [TFN(-0.25,0,0.15); TFN(-0.1,0.15,0.4); TFN(0.15,0.4,0.65); TFN(0.4,0.65,0.9); TFN(0.65,0.9,100)]	R1	ID
PI	{VL, L, M, H, VH} {0.1, 0.3, 0.5, 0.7, 0.9}	{VL, L, M, H, VH} [TFN(-0.25,0,0.25); TFN(0,0.25,0.5); TFN(0.25,0.5,0.75); TFN(0.5,0.75,1.0); TFN(0.75,1,1.25)]		
YOC - SFF	Eq. [3-1]	{VL, L, M, H, VH} [TFN(0,0,1.25); TFN(0,1.25,2.5); TFN(1.25,2.5,3.75); TFN(2.5,3.75,5); TFN(3.75,5,1000)]	R2A	YOC
YOC - DDF	Eq. [3-2]	{VL, L, M, H, VH} [TFN(0,0,1.25); TFN(0,1.25,2.5); TFN(1.25,2.5,3.75); TFN(2.5,3.75,5); TFN(3.75,5,1000)]		
YOC		{VL, L, M, H, VH} [TFN(-0.25,0,0.15); TFN(-0.1,0.15,0.4); TFN(0.15,0.4,0.65); TFN(0.4,0.65,0.9); TFN(0.65,0.9,100)]	R2B	DR
CQ	{Good, Average, Poor} {0.1, 0.5, 0.9}	{VL, L, M, H, VH} [TFN(-0.25,0,0.25); TFN(0,0.25,0.5); TFN(0.25,0.5,0.75); TFN(0.5,0.75,1.0); TFN(0.75,1,1.25)]		
ID		{VL, L, M, H, VH} [TFN(-0.25,0,0.25); TFN(0,0.25,0.5); TFN(0.25,0.5,0.75); TFN(0.5,0.75,1.0); TFN(0.75,1,1.25)]	R3	SV
DR		{VL, L, M, H, VH} [TFN(-0.25,0,0.25); TFN(0,0.25,0.5); TFN(0.25,0.5,0.75); TFN(0.5,0.75,1.0); TFN(0.75,1,1.25)]		
SV		{VL, L, M, H, VH} [TFN(-0.25,0,0.25); TFN(0,0.25,0.5); TFN(0.25,0.5,0.75); TFN(0.5,0.75,1.0); TFN(0.75,1,1.25)]	R4	SBV
BSS	Table 3-12	{VL, L, M, H, VH} [TFN(-0.25,0,0.25); TFN(0,0.25,0.5); TFN(0.25,0.5,0.75); TFN(0.5,0.75,1.0); TFN(0.75,1,1.25)]		
SBV		{VL, L, M, H, VH} [TFN(-0.25,0,0.25); TFN(0,0.25,0.5); TFN(0.25,0.5,0.75); TFN(0.5,0.75,1.0); TFN(0.75,1,1.25)]	R5	SBD
SSH	Sa(T1)	{VL, L, M, H, VH} [TFN(-0.4375,0,0.3); TFN(0,0.3,0.5); TFN(0.3,0.5,0.7); TFN(0.5,0.7,1); TFN(0.7,1,1000)]		
EI	{Negligible, Average, Significant} {0.1, 0.5, 0.9}	{VL, L, M, H, VH} [TFN(-0.25,0,0.25); TFN(0,0.25,0.5); TFN(0.25,0.5,0.75); TFN(0.5,0.75,1.0); TFN(0.75,1,1.25)]	R6	BI/E

BU	Eq. [3-3]	{Low, Normal, High, Post Disaster} [TPFN(-900,-100,5,50); TPFN(5,50,500,750); TPFN(500,750,2700,3000); TPFN(2700,3000,9000,100000)]		
SBD		{VL, L, M, H, VH} [TFN(-0.25,0,0.25); TFN(0,0.25,0.5); TFN(0.25,0.5,0.75); TFN(0.5,0.75,1.0); TFN(0.75,1,1.25)]	R7	SR
B/E		{VL, L, M, H, VH} [TFN(-0.25,0,0.25); TFN(0,0.25,0.5); TFN(0.25,0.5,0.75); TFN(0.5,0.75,1.0); TFN(0.75,1,1.25)]		
YOC	Year Selected	{L,H} [TPFN(1910,1920,1969,1971); TPFN(1969,1971,2010,2010)]	R8	INSH
ID		{VL, L, M, H, VH} [TFN(-0.25,0,0.25); TFN(0,0.25,0.5); TFN(0.25,0.5,0.75); TFN(0.5,0.75,1.0); TFN(0.75,1,1.25)]		
FHL	{VL, L, M, H, VH} {0.1, 0.3, 0.5, 0.7, 0.9}	{VL, L, M, H, VH} [TFN(-0.25,0,0.15); TFN(-0.1,0.15,0.4); TFN(0.15,0.4,0.65); TFN(0.4,0.65,0.9); TFN(0.65,0.9,100)]	R9	NSD
HVO	{VL, L, M, H, VH} {0.1, 0.3, 0.5, 0.7, 0.9}	{VL, L, M, H, VH} [TFN(-0.25,0,0.25); TFN(0,0.25,0.5); TFN(0.25,0.5,0.75); TFN(0.5,0.75,1.0); TFN(0.75,1,1.25)]		
INSH		{VL, L, M, H, VH} [TFN(-0.25,0,0.25); TFN(0,0.25,0.5); TFN(0.25,0.5,0.75); TFN(0.5,0.75,1.0); TFN(0.75,1,1.25)]	R10	NSV
NSD		{VL, L, M, H, VH} [TFN(-0.25,0,0.25); TFN(0,0.25,0.5); TFN(0.25,0.5,0.75); TFN(0.5,0.75,1.0); TFN(0.75,1,1.25)]		
NSV		{VL, L, M, H, VH} [TFN(-0.25,0,0.15); TFN(-0.1,0.15,0.4); TFN(0.15,0.4,0.65); TFN(0.4,0.65,0.9); TFN(0.65,0.9,100)]	R11	NSBV
BSS	Table 3-12	{VL, L, M, H, VH} [TFN(-0.25,0,0.15); TFN(-0.1,0.15,0.4); TFN(0.15,0.4,0.65); TFN(0.4,0.65,0.9); TFN(0.65,0.9,100)]		
NSBV		{VL, L, M, H, VH} [TFN(-0.25,0,0.25); TFN(0,0.25,0.5); TFN(0.25,0.5,0.75); TFN(0.5,0.75,1.0); TFN(0.75,1,1.25)]	R12	NSBD
SSH	Sa(T1)	{VL, L, M, H, VH} [TFN(-0.4375,0,0.3); TFN(0,0.3,0.5); TFN(0.3,0.5,0.7); TFN(0.5,0.7,1); TFN(0.7,1,1000)]		
NSBD		{VL, L, M, H, VH} [TFN(-0.25,0,0.25); TFN(0,0.25,0.5); TFN(0.25,0.5,0.75); TFN(0.5,0.75,1.0); TFN(0.75,1,1.25)]	R13	NSR

B/E		{VL, L, M, H, VH} [TFN(-0.25,0,0.25); TFN(0,0.25,0.5); TFN(0.25,0.5,0.75); TFN(0.5,0.75,1.0); TFN(0.75,1,1.25)]		
SR		{VL, L, M, H, VH} [TFN(-0.25,0,0.15); TFN(-0.1,0.15,0.4); TFN(0.15,0.4,0.65); TFN(0.4,0.65,0.9); TFN(0.65,0.9,100)]	R14	OBR
NSR		{VL, L, M, H, VH} [TFN(-0.25,0,0.25); TFN(0,0.25,0.5); TFN(0.25,0.5,0.75); TFN(0.5,0.75,1.0); TFN(0.75,1,1.25)]		

# Chapter 4

## Sensitivity Analysis

---

### 4.1 General

This chapter presents the results of a sensitivity analysis conducted to verify the seismic risk assessment model proposed in Chapter 3. The effects of various parameters on the outcome of the assessment are investigated.

The sensitivity analysis examines the impact that changes in input parameters will have on the output results. Using this type of analysis, a wide range of scenarios is considered for the input parameters to be able to increase the level of confidence of the model results. For example, considering different scenarios for building vulnerability and the site seismic hazard, the resulting change in building damageability is evaluated and assessed relative to what is expected based on published post disaster surveys and laboratory studies.

### 4.2 Sensitivity Analysis of the Individual Input Parameters

In the hierarchical structure of the proposed model, different performance modifiers (individual input parameters) are aggregated using the rule-base expressions ( $R_i$ ), as illustrated in Chapter 3 (Figures 3-1 and 3-2). As part of the sensitivity analysis, this aggregation is tested by varying the input parameters while observing their effects on output parameters.

To illustrate the methodology, consider the *vertical irregularity* (VI) and *plan irregularity* (PI), which are two input parameters integrated using fuzzy rule base 1 ( $R_1$ ), resulting in a potential *increase in demand* (ID). Considering different levels for VI and PI as input variables, Figure 4-1 illustrates the effect of the change on the resulting ID on a given building. As expected, the figure shows that as the *vertical irregularity* and *plan irregularity* of a building increase, an *increase in demand* of the building is observed.

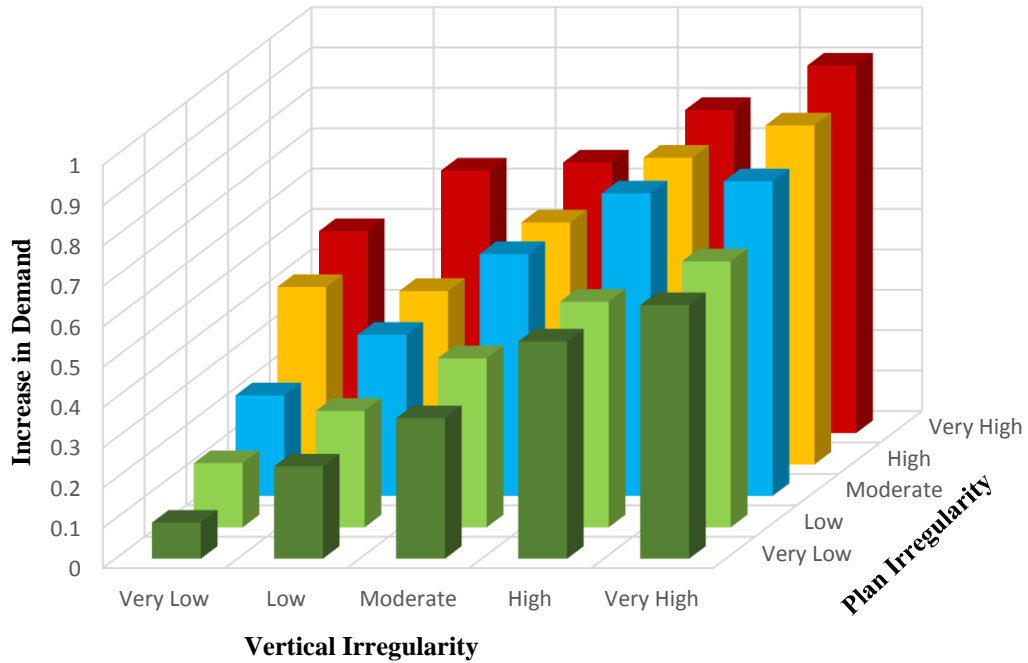

**Figure 4-1: Increase in Demand of a Building**

In the next level of the structural risk hierarchy, the resulting output value of the *increase in demand* is used as an input to be aggregated with the resulting output value of the *decrease in resistance* to compute *structural vulnerability*. The *construction quality* (CQ) and the *year of construction* (YOC) are combined using the fuzzy rule base 3 ( $R_3$ ) to compute *decrease in resistance* (DR) of the building, as seen in level 5 of Figure 3-1. To examine the effect of different levels of ID and DR on the resulting *structural vulnerability*, two extreme scenarios are considered. The “worst case” scenario for DR, shows the results of a building’s *structural vulnerability* as a function of the PI and VI of a building built prior to 1940 with poor CQ, as seen in Figure 4-2. In the “best case” scenario for DR, the same variation is considered for a building constructed according to modern code provisions with a good construction quality, as shown in Figure 4-3. A comparison of the results generated in Figures 4-2 and 4-3 shows the difference in *structural vulnerability* between a building built in 2010 with good *construction quality* and that built with poor *construction quality* prior to 1940.

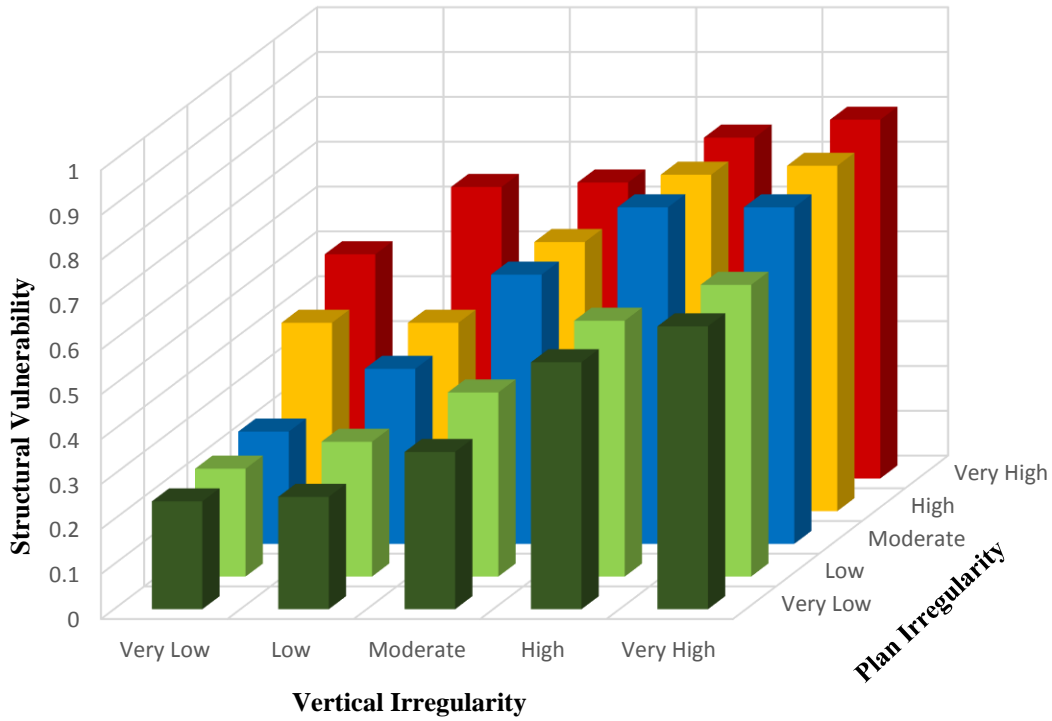

Figure 4-2: Structural Vulnerability of a Building built prior to 1940 with poor construction quality

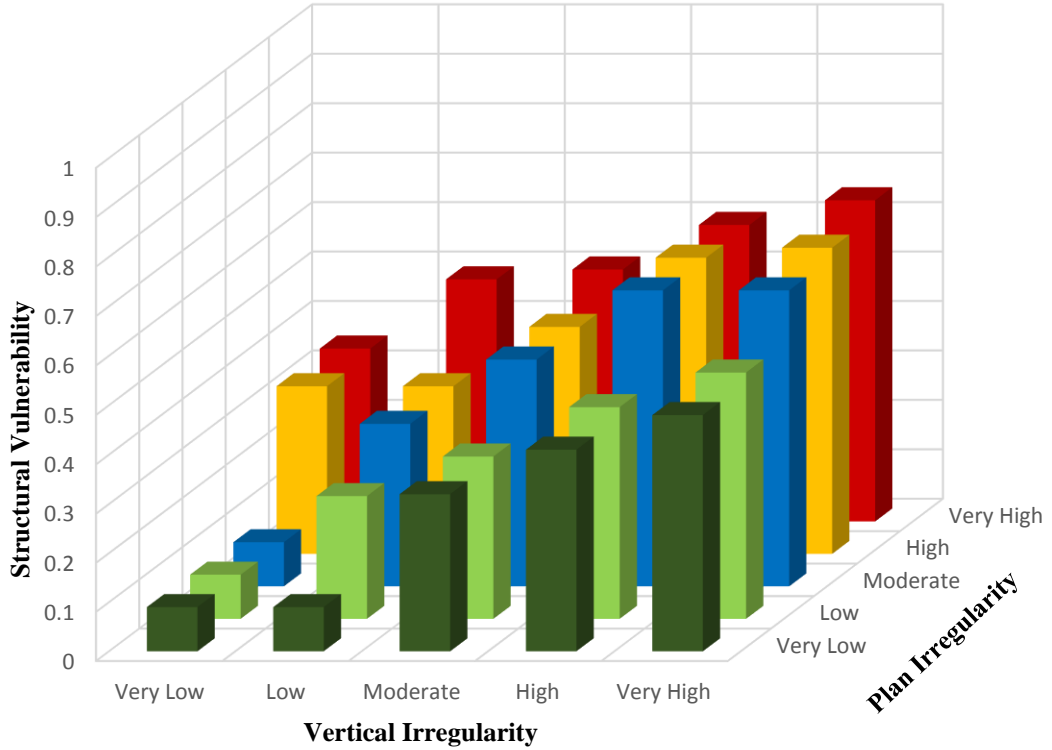
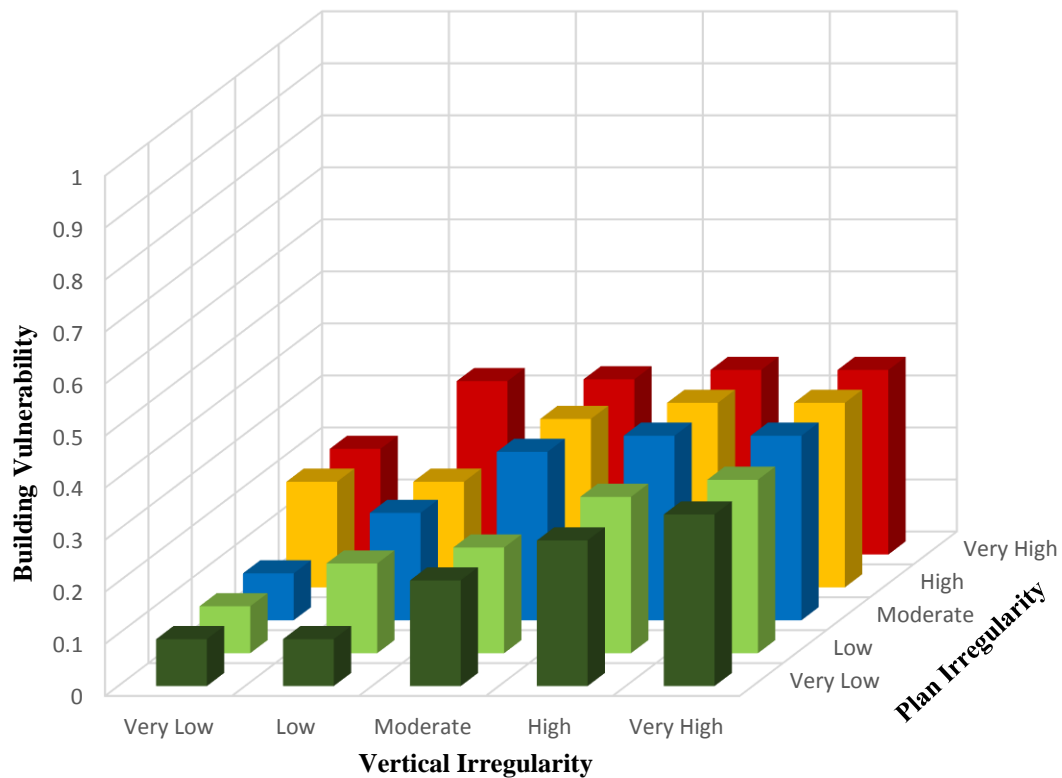
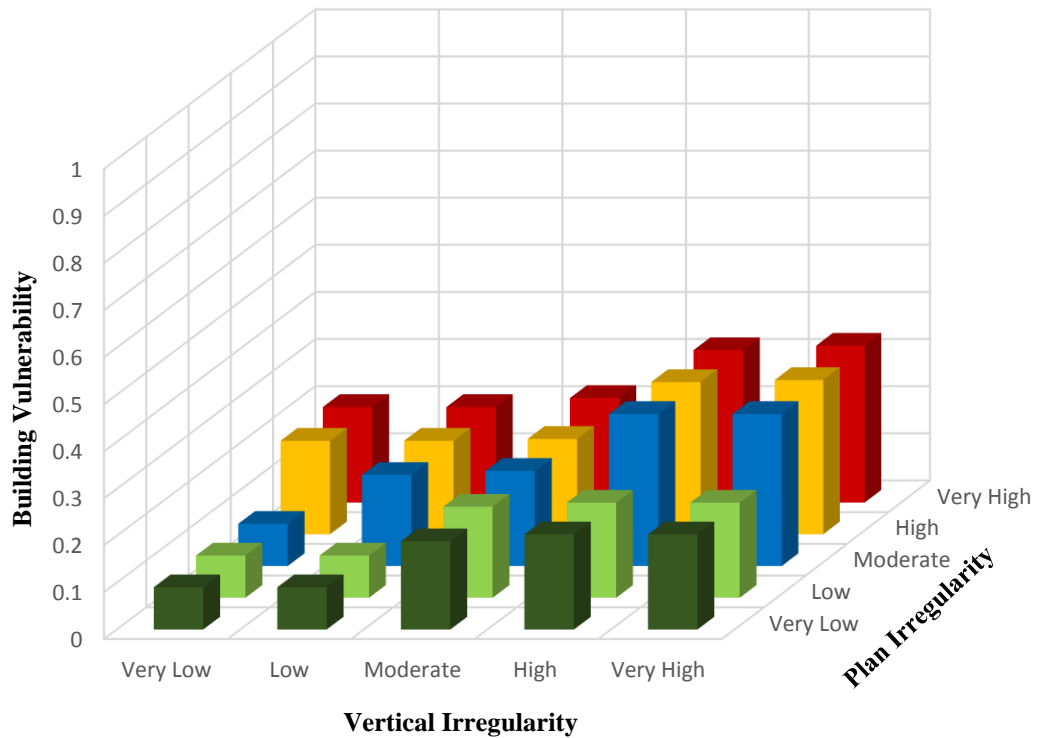

Figure 4-3: Structural Vulnerability of a Building built in 2010 with good construction quality

In level 4 of the hierarchy, *building structural system* is combined with *structural vulnerability* to compute *building vulnerability*. Figure 4-4 and Figure 4-5, illustrate the effect of the *building structural system* (wood light frame structure sheathed with wood structural panel), on the resulting *building vulnerability* in two aforementioned extreme scenarios. As seen in the figures, the wood framed building constructed prior to 1940 with poor *construction quality*, has higher *building vulnerability* than the building built after 2010 with good *construction quality*. It is noteworthy that in this case, due to the fact that a structural system with good performance is used, the resulting value remains in the “low range” of the *building vulnerability* even in the worst case scenario.



**Figure 4-4: Building Vulnerability of a Wood Light Frame Building built prior to 1940 with poor construction quality**

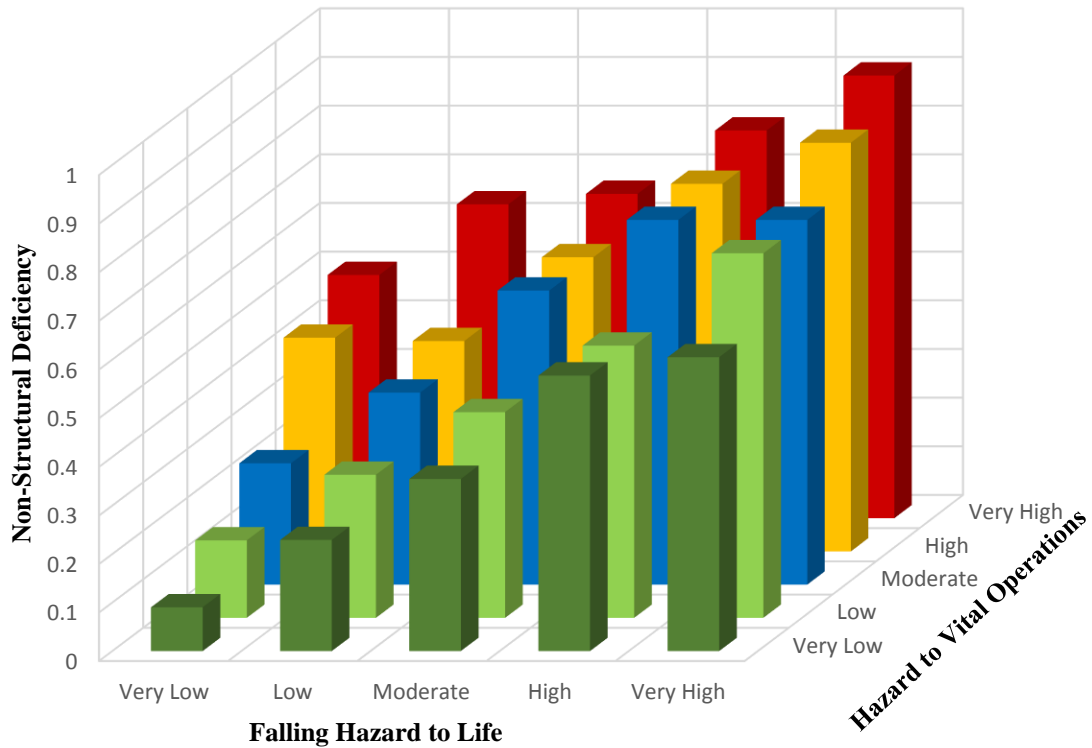

**Figure 4-5: Building Vulnerability of a Wood Light Frame Building built in 2010 with good construction quality**

In the non-structural risk hierarchy, the *falling hazards to life* (FHL) and *hazards to vital operations* (HVO) are combined using fuzzy rule base 9 ( $R_9$ ) to compute the *non-structural deficiency* (NSD) of a building. Considering different levels for FHL and HVO as input variables, Figure 4-6 illustrates the effect of these input variables on the resulting NSD of a building. As seen in the figure, as the FHL and HVO of a building increase so does the NSD of the building. In the next level of the non-structural risk hierarchy, the resulting output value of the NSD is used as an input to be aggregated with the resulting output value of the *increase in non-structural hazard* (INSH) to compute *non-structural vulnerability* (level 4 of Figure 3-2). INSH is computed by aggregating the *year of construction* and level of *increase in demand* of a building.

To examine the effect of different levels of NSD and INSH on the resulting *non-structural vulnerability*, two extreme scenarios were considered. The worst case scenario for INSH

represents the results of a building's *non-structural vulnerability* as a variation of the FHL and HVO of a building built prior to 1970 with a very high ID, as seen in Figure 4-7. In the best case scenario, the same variation is considered for a building constructed according to the modern code provisions with a very low ID, as seen in Figure 4-8. Comparing the results from both figures, it can be clearly seen that the building built in 2010 with a very low ID has a lower *non-structural vulnerability* than a building with a very high ID built prior to 1970.



**Figure 4-6: Non-structural deficiency of a Building**

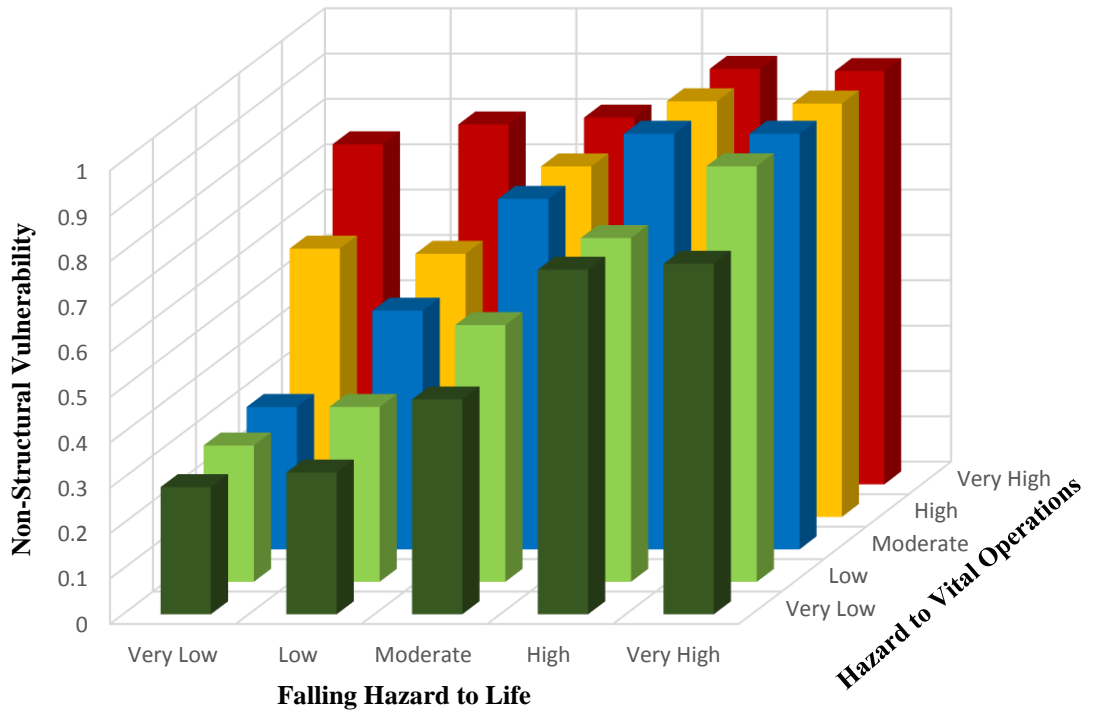

Figure 4-7: Non-Structural Vulnerability of a Building built prior to 1970 with very high ID

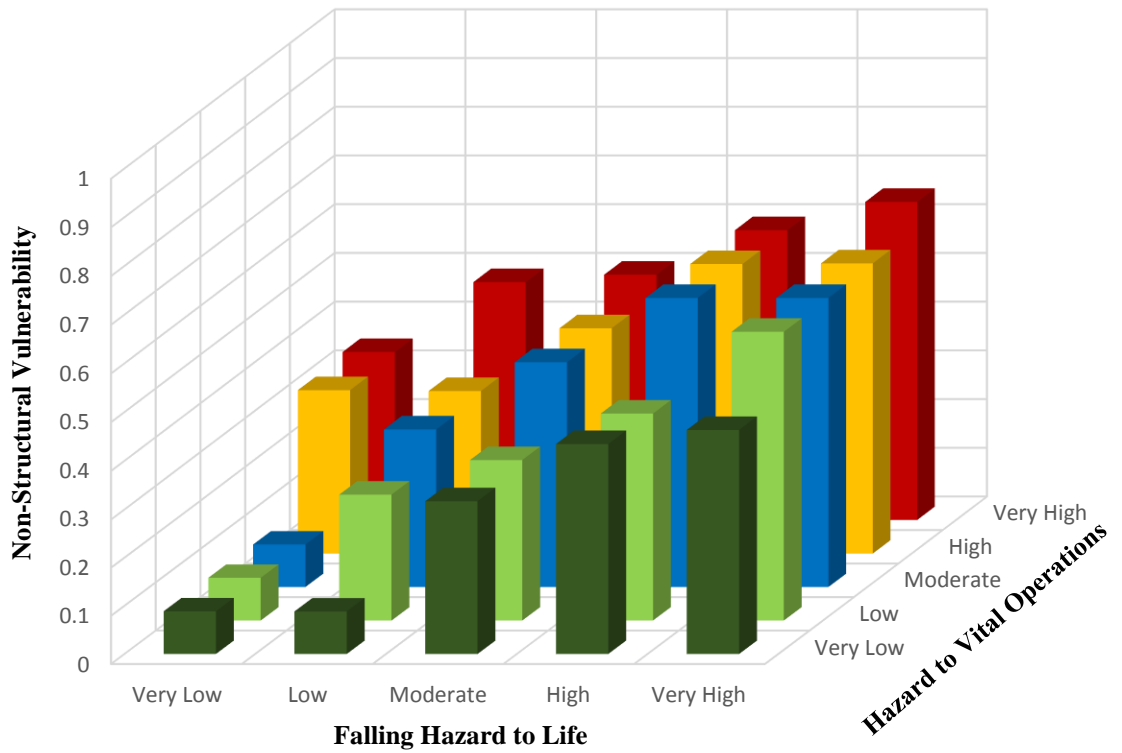

Figure 4-8: Non-Structural Vulnerability of a Building built in 2010 with very low ID

### 4.3 Sensitivity Analysis of the Structural Building Damageability Index

In this section, the impact of the aggregation of multiple modules and their corresponding parameters on the resulting *structural building damageability index* ( $I_s^{BD}$ ) is tested. The *structural building damageability* is computed by integrating *site seismic hazard* (SSH) module and *structural building vulnerability* (SBV) module, as seen in Level 2 of Figure 3-1. By varying the parameters in these two modules, the upper and lower bound limits of the *structural building damageability index* ( $I_s^{BD}$ ) is obtained. To test the sensitivity of the *structural building damageability*, extreme scenarios for *structural building vulnerability* were considered (very low and very high vulnerability). Also conditions for *site seismic hazard* were varied by considering different soil types and number of stories.

The results of the analysis, including the two extreme cases, are illustrated in Figures 4-9 to 4-21, as well as in Appendix A. It is important to note that the results in the graphs are presented as a function of number of stories up to 30 stories. This number was chosen simply to clearly illustrate the trends, with no considerations to whether the structural systems are capable of reaching a certain height or whether they would be optimum in a certain height range. For example, it is more common to see one- and two-story light wood frame structures. Furthermore, the current code regulations do not permit modern day light wood frame structures to be of more than 6 stories in height, though there exist timber buildings in North America that are 9 stories in height. Worldwide, there are several examples of timber buildings that are (or have heights that are equivalent to) twenty to thirty meters. In other words, in this section it is assumed that the considered structural system is capable of achieving the proposed height range between 1 and 30 stories, even if in reality it may be impractical or even not allowed by the design codes and standards. The analysis simply presents comparative performance of various structural systems.

The upper bound limits (illustrated here as dotted lines) represent the performance of a building type evaluated for worst case scenario (very high vertical and plan irregularity, poor construction quality, built prior to 1940), while lower bound limits (solid lines) represent the performance of a building type evaluated at best case scenario (very low vertical and plan irregularity, good construction quality, built in 2010 or after). Figures 4-9 to 4-19 show the results of this analysis conducted for different types of wood frame construction. The structural

systems range from what is considered to be the best structural type represented by engineered light frame sheathed with wood structural panel, to what is considered the worst type represented by non-engineered light frame sheathed with shiplaps or horizontal lumber. The comparisons are made for structures located in Edmonton, Ottawa, Victoria, representing areas of low, moderate and high seismicity, respectively. The results of the analysis conducted for different types of wood-framed building in Edmonton and Victoria are included in Appendix A.

An important part of conducting the sensitivity analysis is to compare the results from the software based on the aggregated variables with what is expected based on established knowledge in earthquake engineering. This would provide a level of confidence in the operation of model and its ability to correctly account for multiple variables. It is, for example, observed that short period buildings are experiencing higher damage levels when compared to longer period structures. This trend is expected, since based on the modern seismic design force requirements, the forces increase in the short period region as the building spectral acceleration increases (Heidebrecht, 2003, Elsabbagh, 2013). The results also show that buildings built on soil type D and E (stiff and soft soils) are experiencing higher damage than the ones built on soil type A and B (hard rock and rock).

Furthermore, the results show lower damageability of the engineered light wood frame buildings sheathed with wood structural panels (WSP) compared to other structural systems. The heavy timber post and beam structures with shearwalls also has the same low damageability as seen in light frame sheathed with WSP, because light frame shearwalls are the ones assumed to resist seismic forces (they act as the only Seismic Force Resisting Systems, SFRS), whereas the post and beam system only resist gravity loads. Traditional timber frame and light frame sheathed with wood based wallboards (WBW) show the same level of low damageability in the “best case” scenario as that observed in light frame sheathed with WSP. This is consistent with post disaster damage surveys where well-constructed timber framed buildings and light frame structures constructed using prescriptive rules have performed very well. It should be noted that such observations have been based on low rise buildings only (mostly one and two stories) and extending the performance of light frame structures sheathed with wood based wallboards to taller buildings may not be merited. In the

worst case scenario, however, traditional timber frame and light frame sheathed with wood based wallboards are both expected to experience higher damage than that expected in light frame buildings sheathed with WSP. The results also show the high vulnerability of the light frame buildings sheathed only with gypsum wallboards, stucco, horizontal lumbers and shiplaps, which due to the brittle nature of the sheathing and lack of lateral load resisting capacity, show relatively higher damageability values when compared to other wood-framed buildings.

As anticipated, Figures 4-15 to Figure 4-18 demonstrate that as the seismicity increases so does the structural building damageability. Also, the curves of the best case scenario (lower bound curve) and worst case scenario (upper bound curve) are further apart in the cities with higher seismicity. For example, a light wood frame building sheathed with WSP in Victoria shows a large range of building damageability when considering upper and lower bound limits, but this range is smaller in Edmonton. The range of damageability in the best and worst case scenario not only depends on seismicity but is also effected by the type of structure. For example for wood light frame sheathed with WSP, lower and upper bound curves are closer together when compared to other building types, as seen in Figures 4-19 to 4-21.

A sensitivity analysis was conducted to compare the behaviour of wood frame construction with that obtained from structural systems from other materials, which were developed completely independently by Elsabbagh (2013), as seen in Figure 4-19 to 4-21. The results of this analysis show the low vulnerability of wood light frame buildings, which show relatively lower damageability values in worst case scenario when compared to building types C1(Concrete Moment Frame), C2(Concrete Shear wall), and URM (Unreinforced Masonry) buildings. In the best case scenario, wood light frame has approximately the same range of low damageability compared to C1 and C2 in different cities.

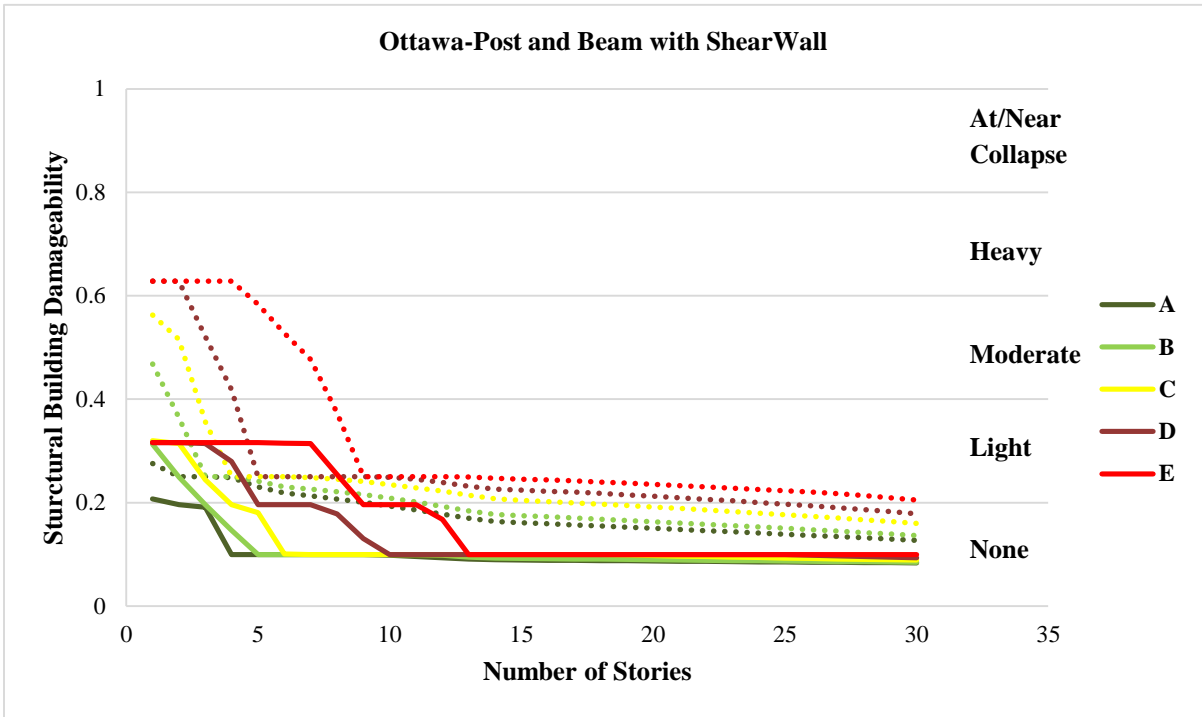

Figure 4-9: Upper and Lower Bound Limits of Building Damageability for Post and Beam Structures resting on various soil conditions in Ottawa, Ontario

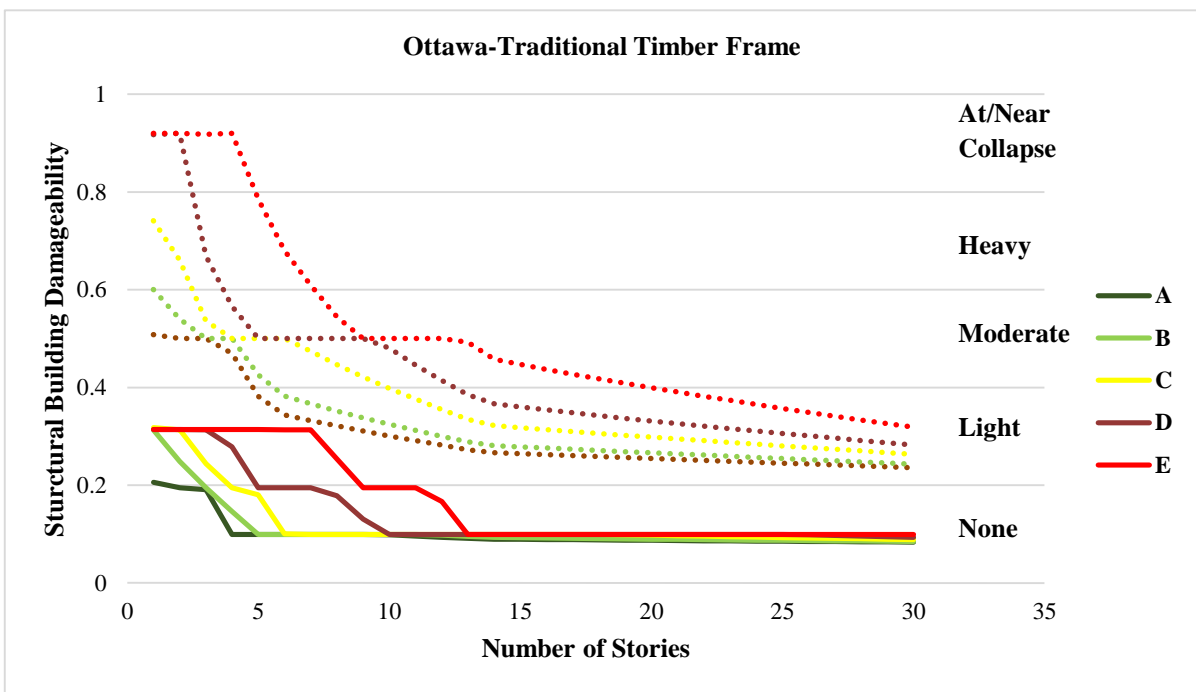
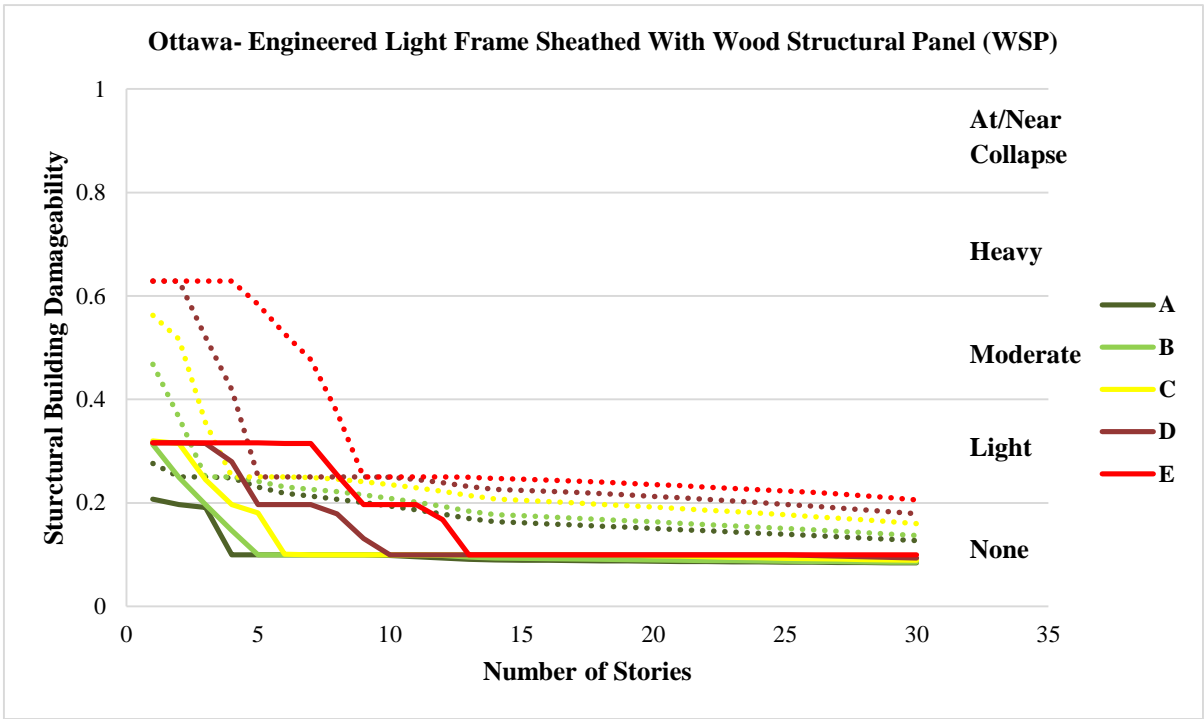
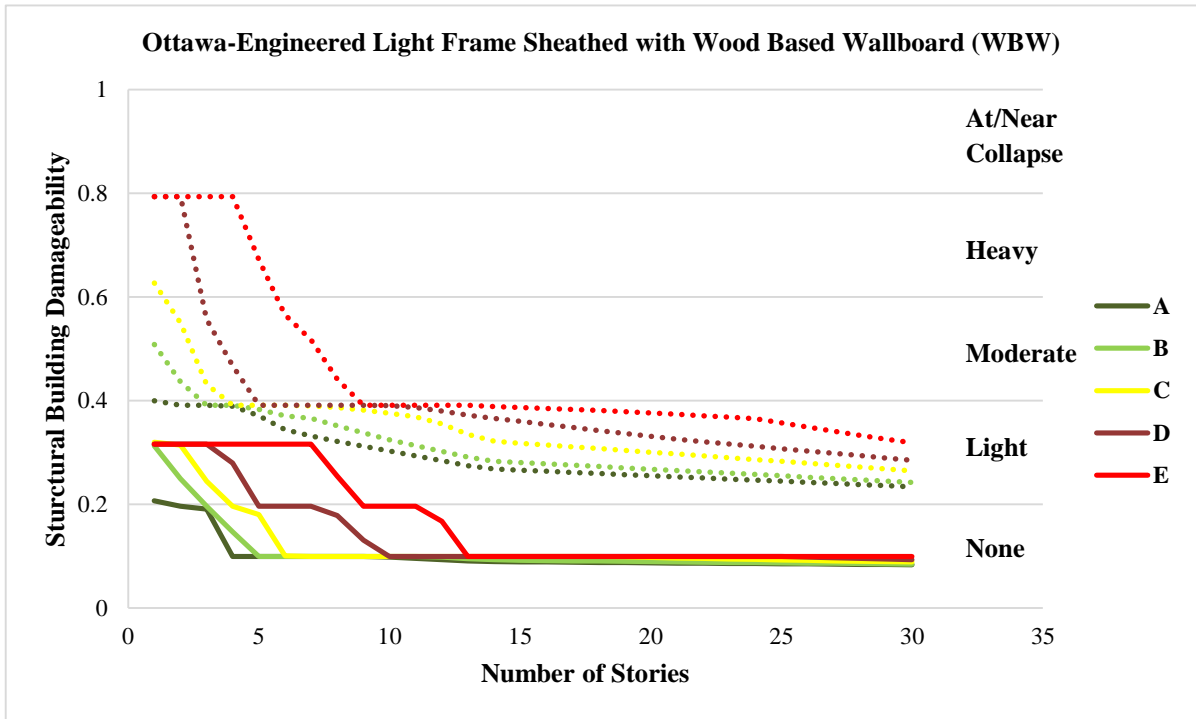

Figure 4-10: Upper and Lower Bound Limits of Traditional Timber Frame Structures resting on various soil conditions in Ottawa, Ontario



**Figure 4-11: Upper and Lower Bound Limits of Building Damageability for Engineered Light Wood Frame Structures sheathed with WSP resting on various soil conditions in Ottawa, Ontario**



**Figure 4-12: Upper and Lower Bound Limits of Building Damageability for Engineered Light Wood Frame Structures sheathed with WBW resting on various soil conditions in Ottawa, Ontario**

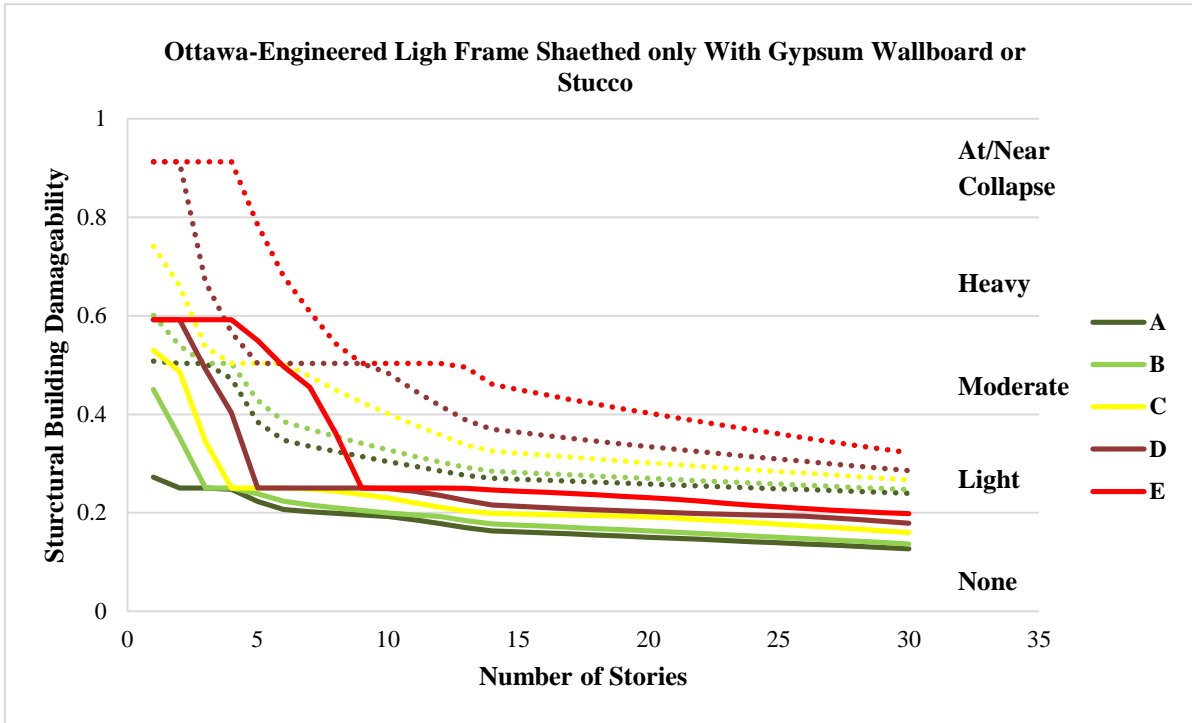

**Figure 4-13: Upper and Lower Bound Limits of Building Damageability for Engineered Light Wood Frame Structures sheathed only with Gypsum Wallboard or Stucco resting on various soil conditions in Ottawa, Ontario**

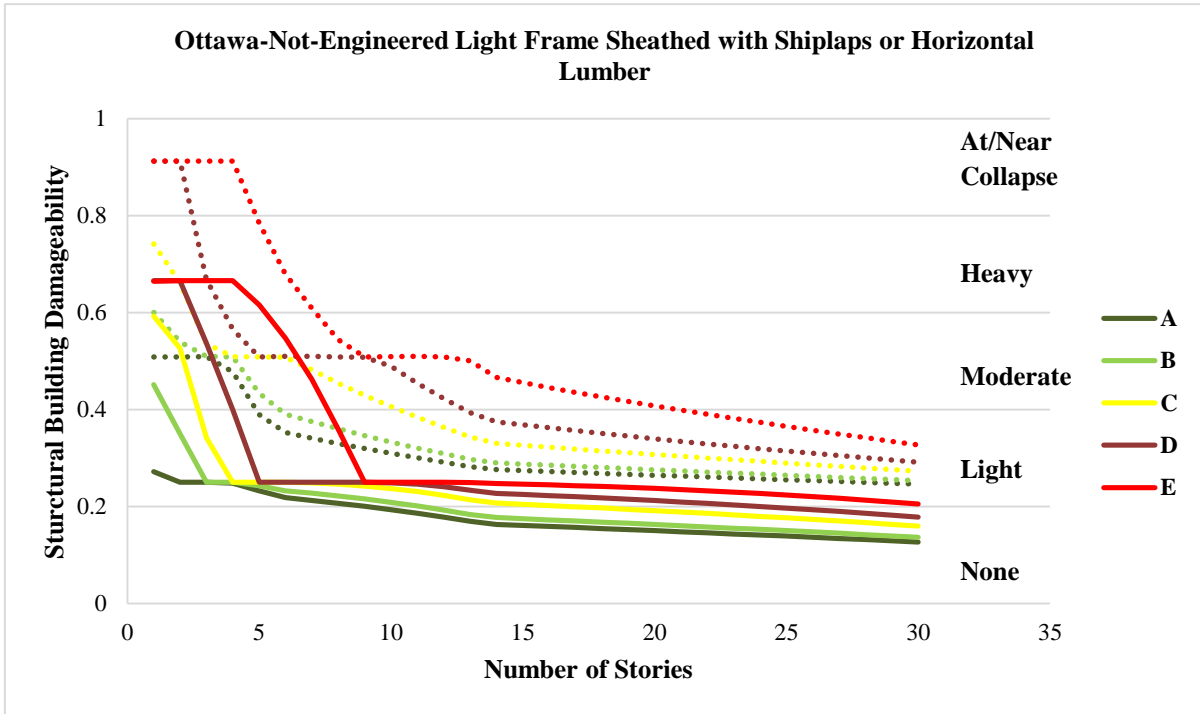

**Figure 4-14: Upper and Lower Bound Limits of Building Damageability for Non-Engineered Light Wood Frame Structures sheathed with Horizontal Lumber or Shiplaps resting on various soil conditions in Ottawa, Ontario**

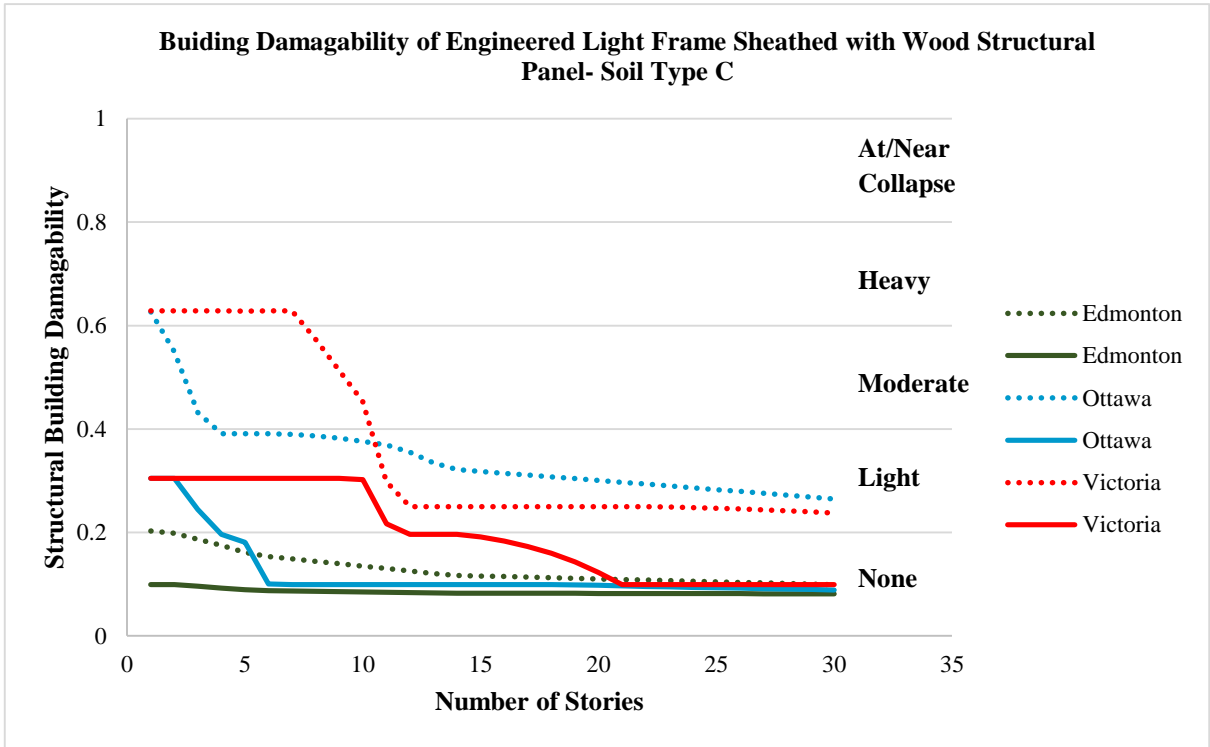

Figure 4-15: Comparison of Upper and Lower Bound Limits of Building Damageability for Engineered Light Frame structures sheathed with WSP, Resting on Reference Site Soil Class C

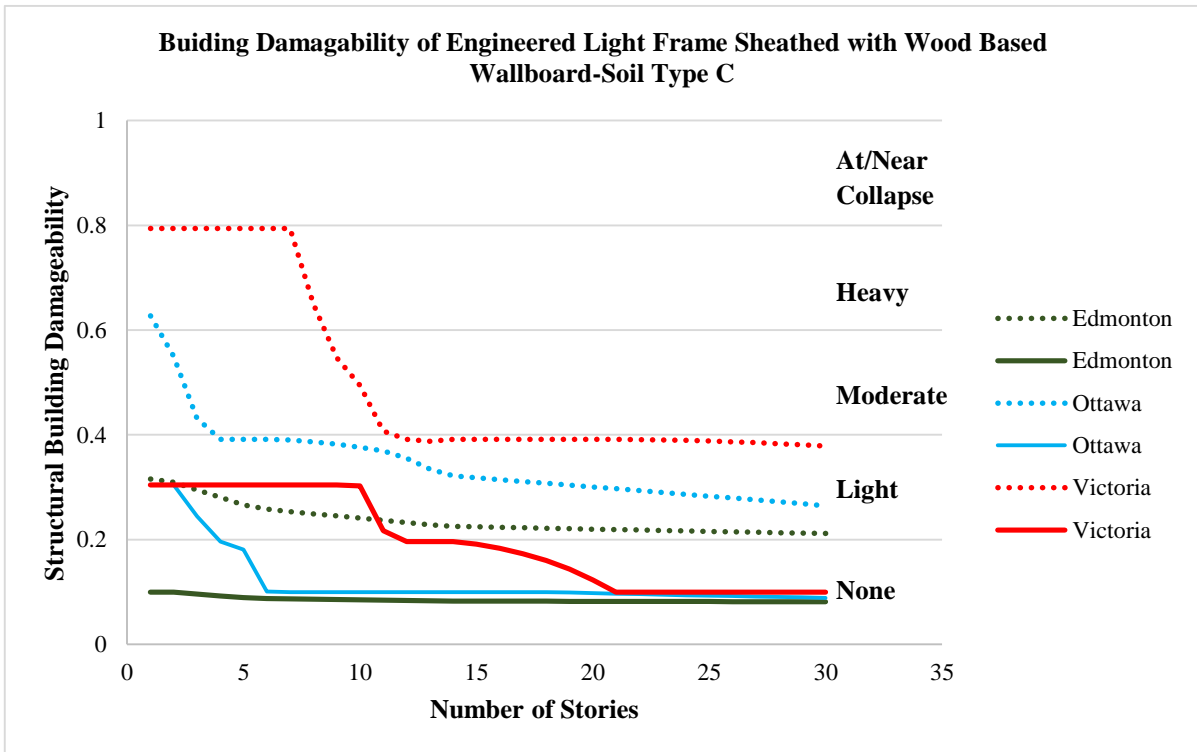

Figure 4-16: Comparison of Upper and Lower Bound Limits of Building Damageability for Engineered Light Frame structures sheathed with WBW Resting on Reference Site Soil Class C

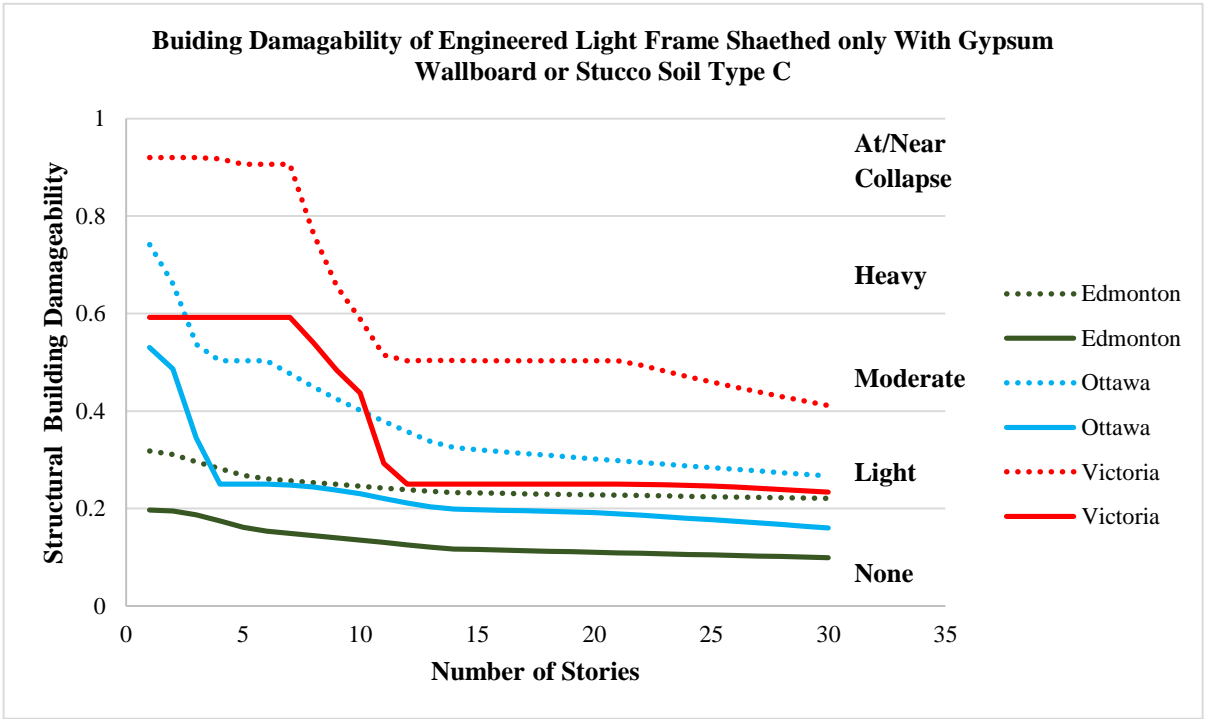

Figure 4-17: Comparison of Upper and Lower Bound Limits of Building Damageability for Engineered Light Frame structures sheathed Only with Gypsum Wallboard or Stucco Resting on Reference Site Soil Class C

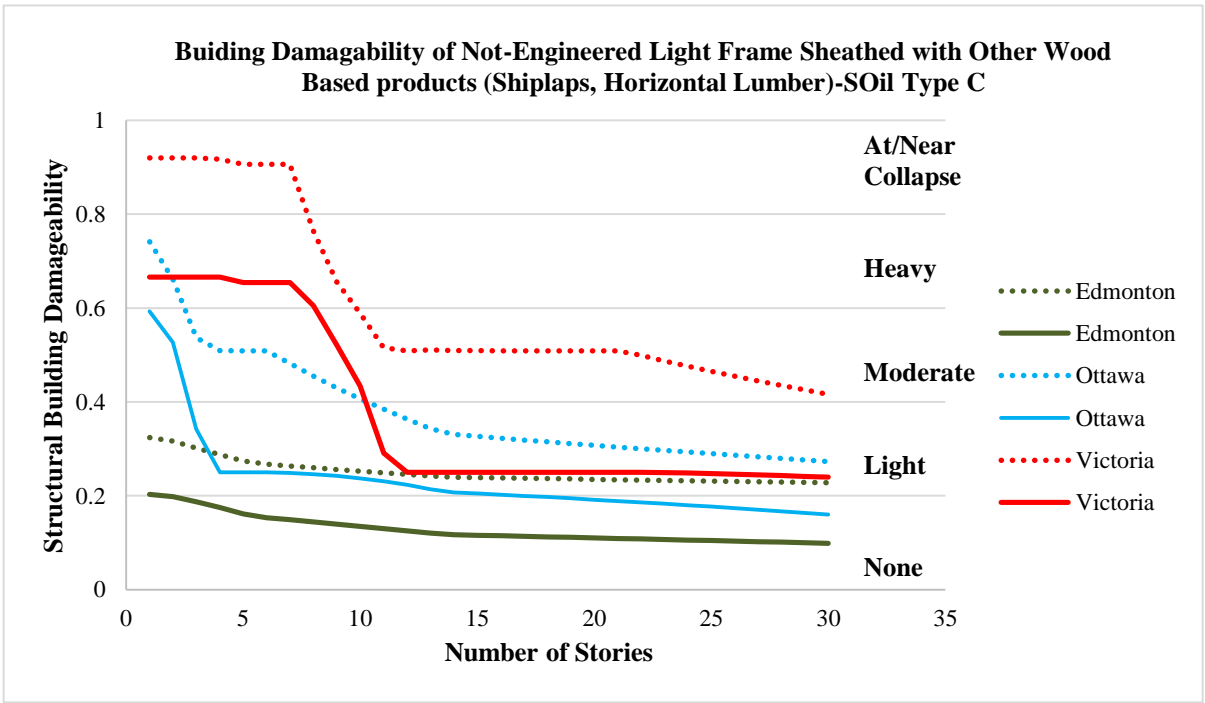

Figure 4-18: Comparison of Upper and Lower Bound Limits of Building Damageability for Non-Engineered Light Frame structures sheathed with Horizontal Lumber or Shiplaps Resting on Reference Site Soil Class C

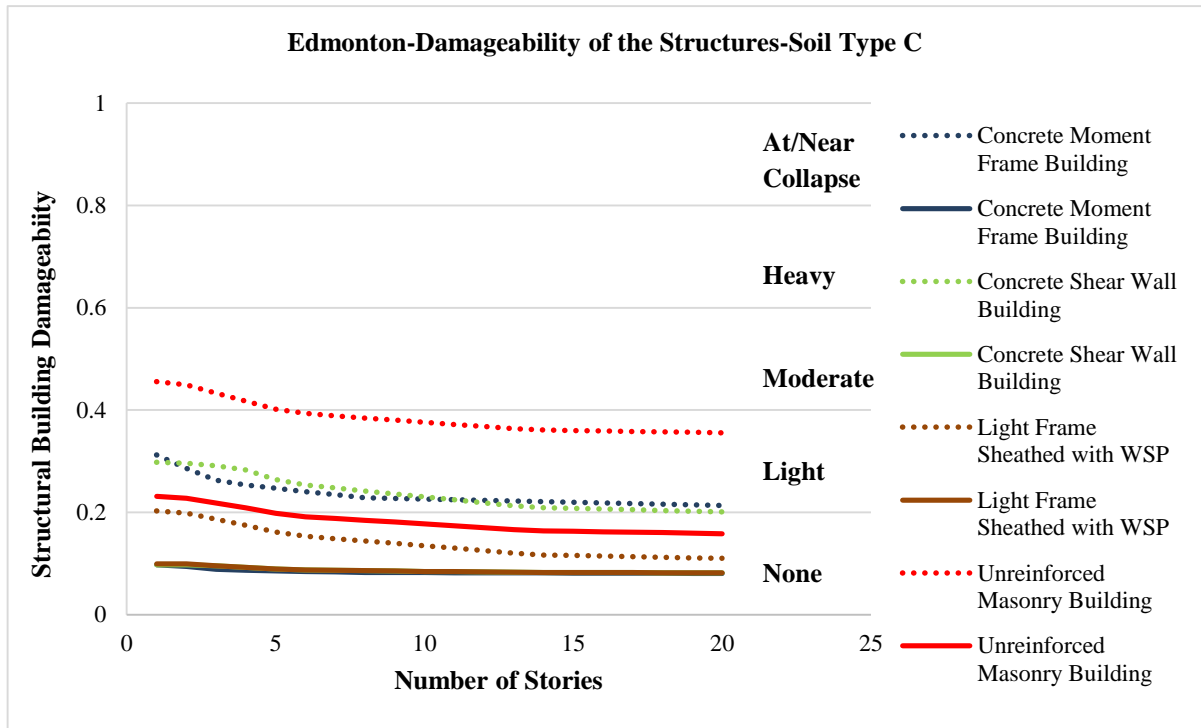

Figure 4-19: Comparison of Building Type for Structural Building Damageability of Structures Resting on Reference Site Soil Class C in Edmonton, AB

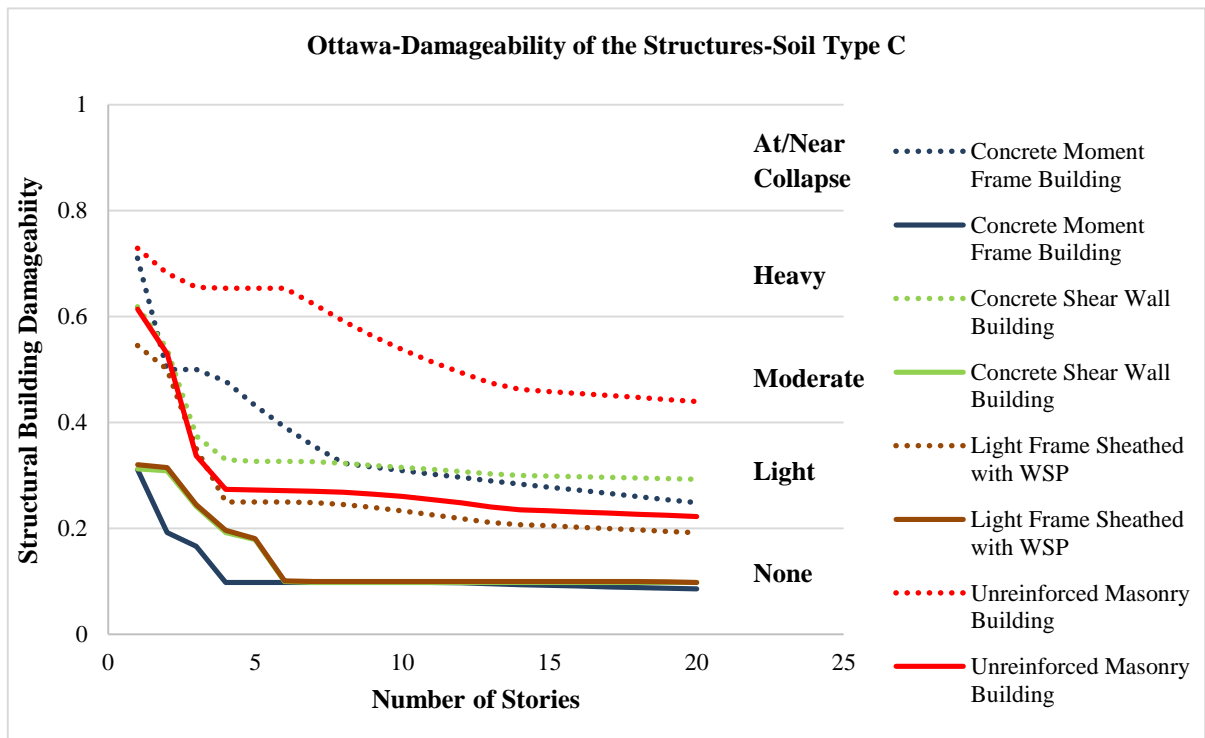
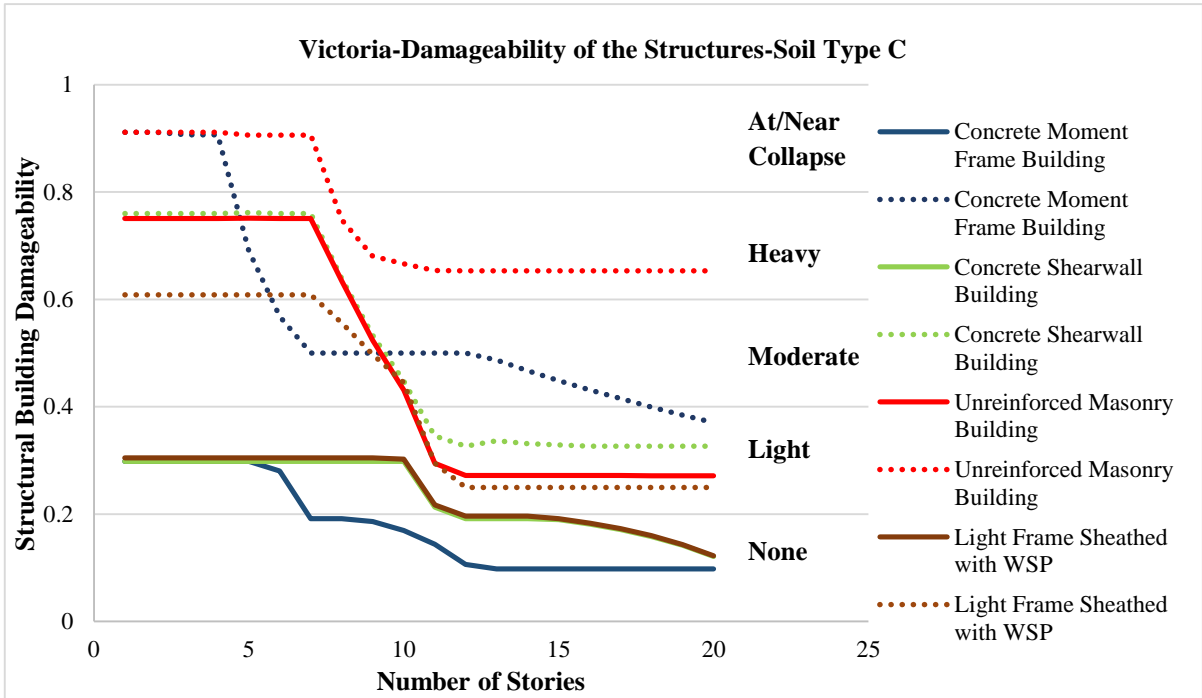

Figure 4-20: Comparison of Building Type for Structural Building Damageability of Structures Resting on Reference Site Soil Class C in Ottawa, ON



**Figure 4-21: Comparison of Building Type for Structural Building Damageability of Structures Resting on Reference Site Soil Class C in Victoria, BC**

# Chapter 5

## CanRisk Seismic Risk Assessment of Wood Framed Buildings

### A Case Study for the City of Ottawa

---

#### 5.1 General

Among the Canadian urban areas, the Ottawa- Gatineau region is ranked third in terms of earthquake hazard (Lamontagne, 2010). The continuous growth of the urban areas in this region puts more population and building stock at risk, and makes it more important to assess the seismic vulnerability of the buildings in this region. Also, similar to other Canadian cities, wood frame construction is the most common construction type in Ottawa (more than 80 percent). Therefore, considering this large number of wood framed-buildings at risk, there is a need for seismic assessment of wood-framed buildings in this region to identify the seismically deficient buildings and mitigate potential seismic related losses.

In this chapter, using data collected from the urban rapid assessment tool (UrbanRAT) (Sawada et al., 2013), a detailed evaluation of a number of wood framed buildings in the city of Ottawa is presented using CanRisk. The UrbanRAT tool is designed for rapid collection of building data in urban centers, and together with information obtained from Google Street View and site visits, it is possible to provide a detailed assessment of any building type or structural system. Also, a summary of the building data collected by UrbanRAT, specifically used for the seismic risk assessment of existing wood-framed buildings in the city of Ottawa, is presented in the following section, including the spatial distribution and breakdown of construction type, number of stories, local soil conditions, year of construction, and occupancy classes.

#### 5.2 UrbanRAT Wood-Framed Building Inventory

Eight neighborhoods were identified as primary focus areas to collect data for seismic risk assessment of buildings in the City of Ottawa, using UrbanRAT, including Centretown, West Centretown, Lowertown, Sandy Hill, Ottawa East, Glebe – Dows Lake and Ottawa South, as

illustrated in Figure 5-1. As seen in the figure, a large inventory of wood-framed buildings (identified in black) was included in the assessment.

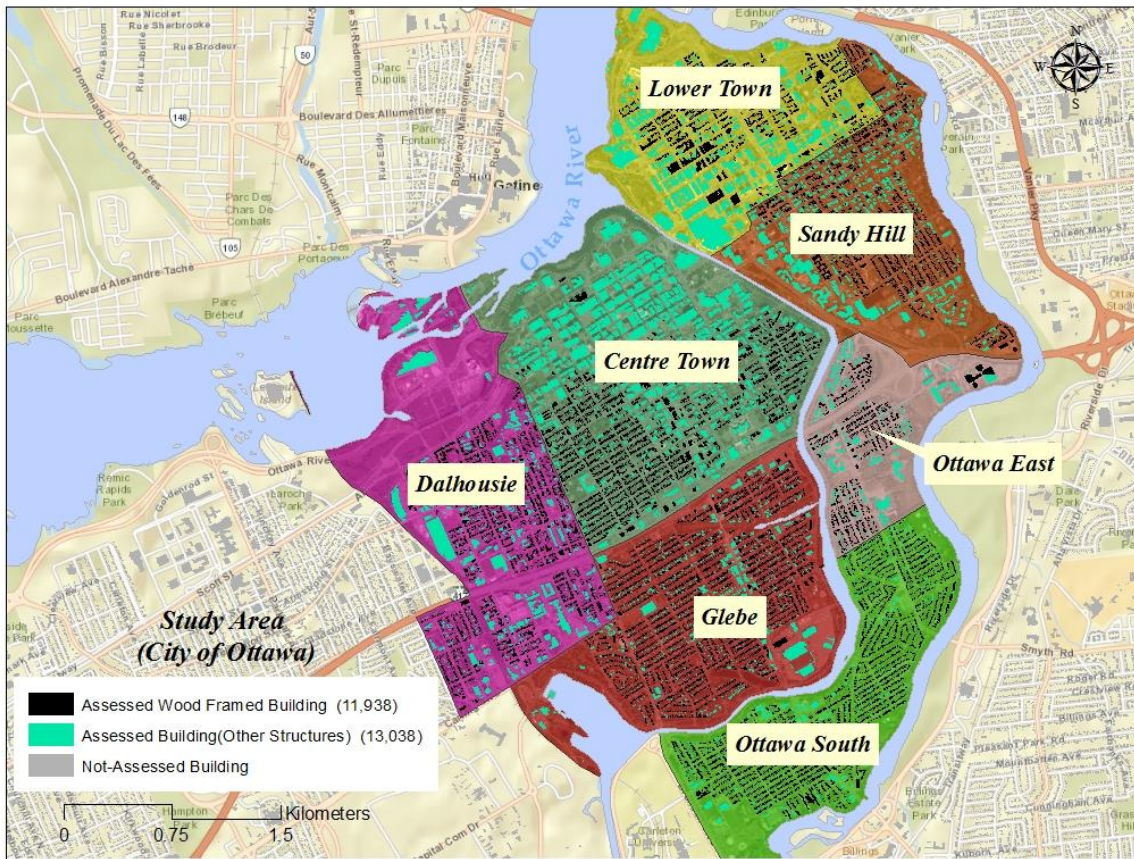

**Figure 5-1: Study Area**

Among the entire inventory of 13,038 buildings, 11,938 buildings were of wood frame construction. The buildings were divided into two categories based on FEMA 154 (ATC, 2002): 1) W1: Light wood frame residential and commercial buildings equal to or smaller than 5000 ft<sup>2</sup> (465 m<sup>2</sup>); 2) W2: Light wood frame buildings greater than 5000 ft<sup>2</sup> (465 m<sup>2</sup>). Figure 5-2 presents the spatial distribution of wood frame construction types within the study area. As seen in the figure, the majority of wood-framed buildings assessed in this study can be classified as W1 (about 99%).

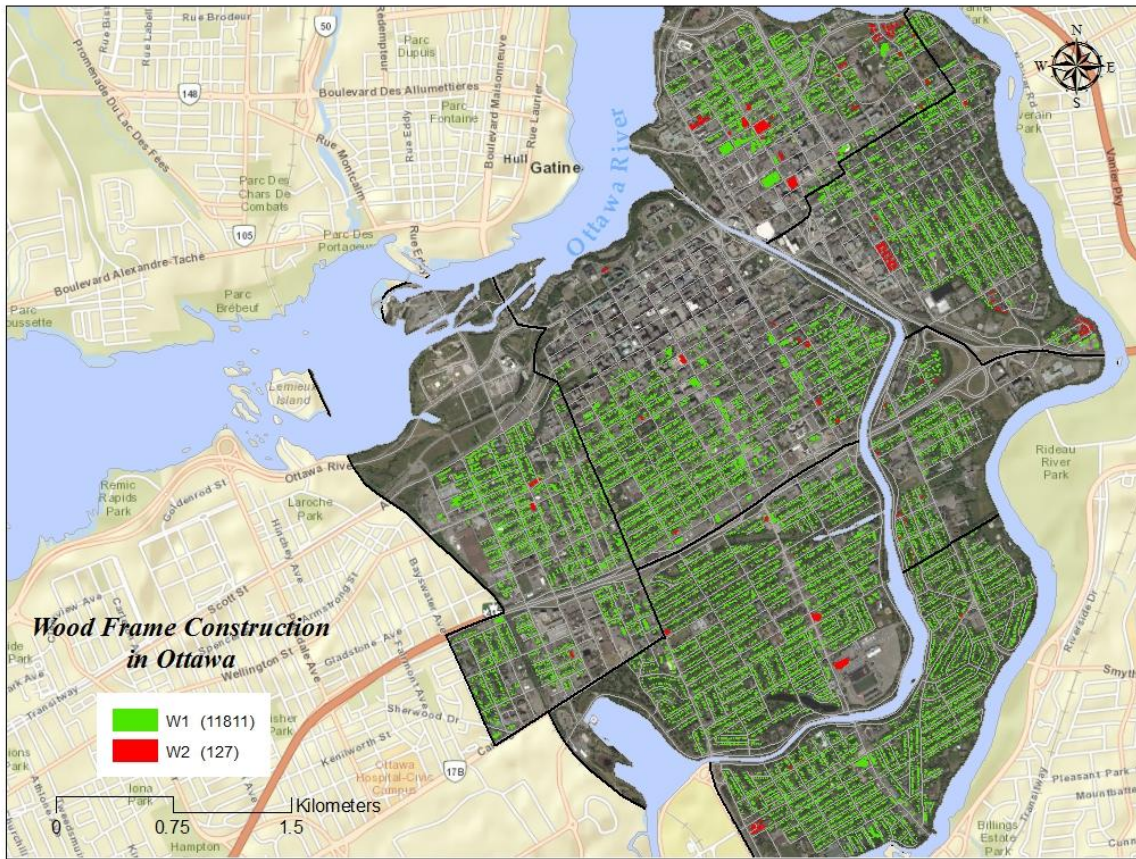

**Figure 5-2: Spatial Distribution of Construction Type of Wood Framed Buildings in Ottawa, Ontario**

In addition to the structural type, an important variable in assessing seismic vulnerability is building's fundamental period. One of the important elements affecting fundamental period of the buildings and consequently the site seismic hazard is number of stories. As seen in Figure 5-3, of the wood-framed buildings assessed, more than 60% consists of two story buildings, while the remainder of the wood-framed building stock has mostly 1 or 3 stories (more than 38%). Buildings consisting of three stories or less would fall in the short period range.

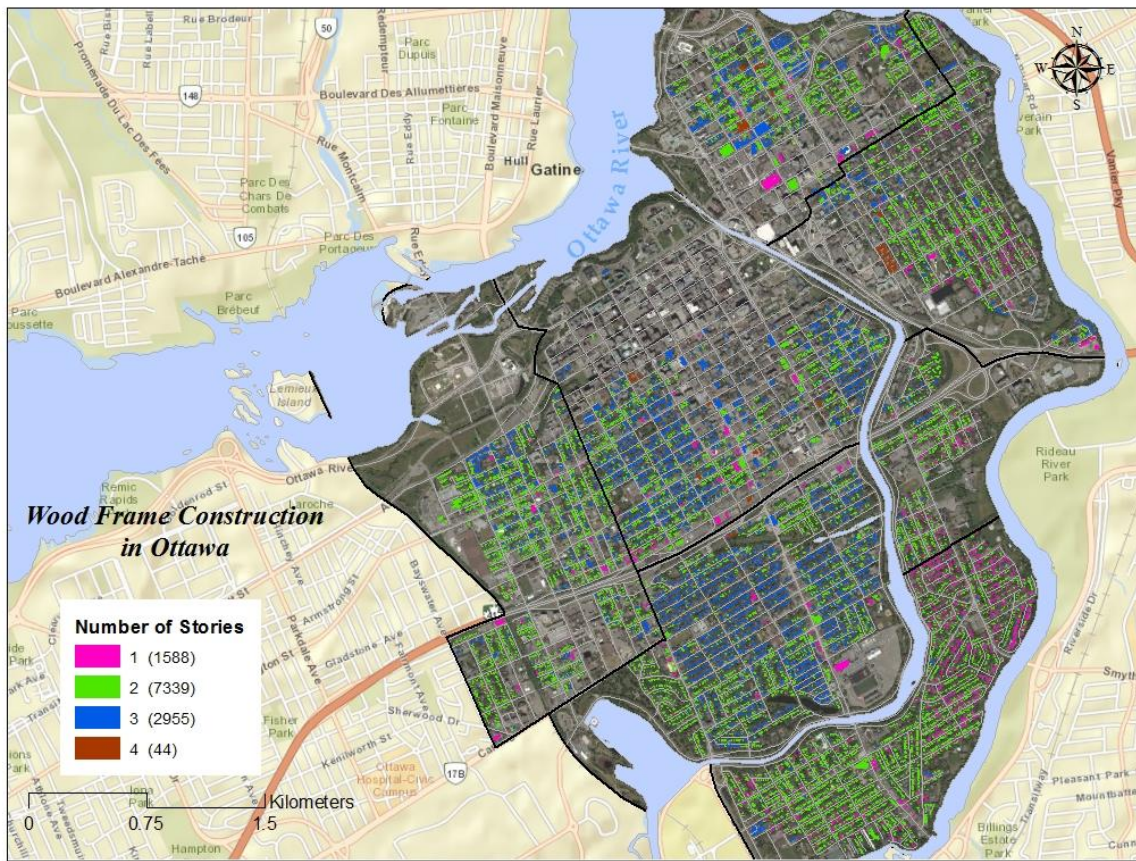

**Figure 5-3: Spatial Distribution of the Wood Framed Buildings' Number of Stories in Ottawa, Ontario**

The other important factor in the seismic vulnerability assessment is the soil condition of the site where a building is located. Figure 5-4 illustrates the spatial variability of site soil classification in the city of Ottawa (Hunter et al., 2010; Motazedian et al., 2011). As seen in the figure, about 34% of the wood-framed buildings assessed are constructed on stiff or soft soil conditions (Class D & E), while the remainder of the building stock are constructed on hard rock or very dense soil profiles (Class A, B, C)

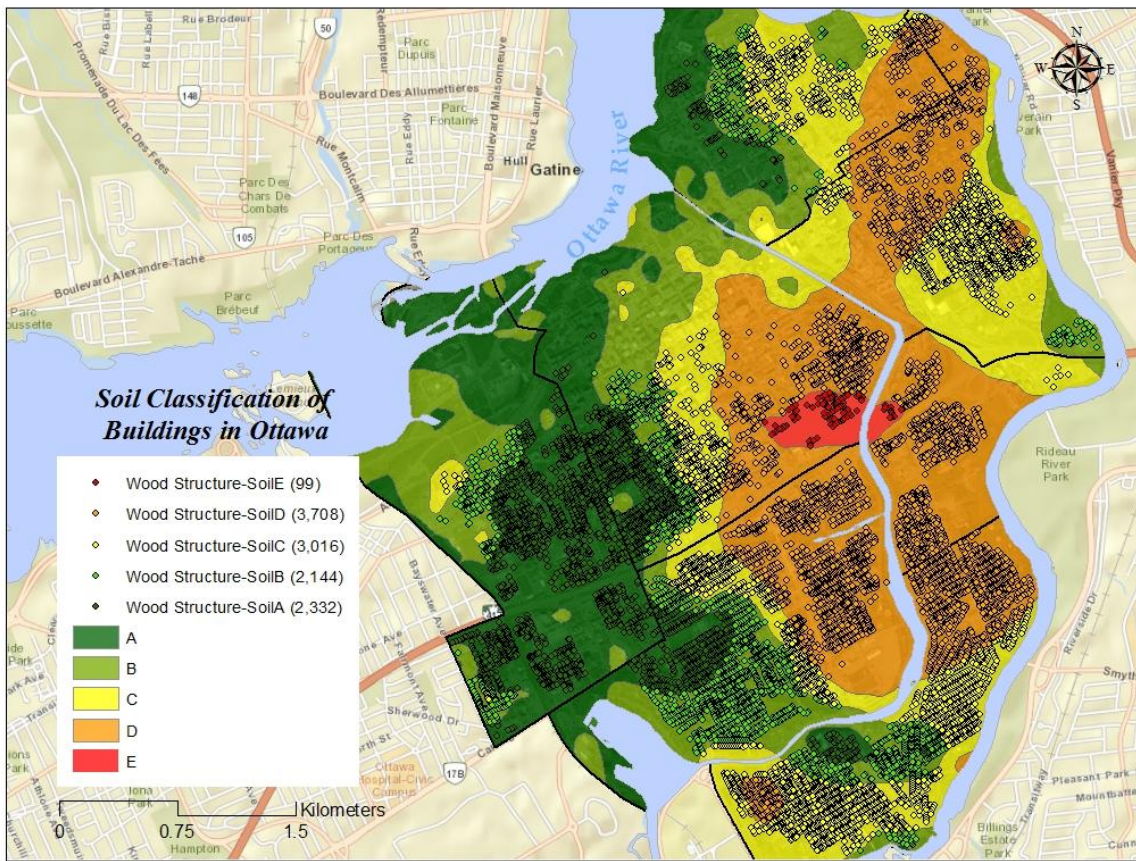

**Figure 5-4: Spatial Distribution of Soil Classification of Buildings in Ottawa, Ontario**

The year of construction also influences the seismic performance of buildings. As reported in Chapter 3, the year of construction considers the evolution of the code and design standards, as well as common practice in construction. The first edition of the engineered design in wood (CSA O86) was published in 1959, and it was in 1965 when the first residential standard was published in Canada. As illustrated in Figure 5-5, about 90% of the assessed wood-framed buildings in the city of Ottawa were built prior to 1965, indicating the presence of a large number of non-engineered and old wood buildings in the city of Ottawa, which can significantly affect the vulnerability of these buildings.

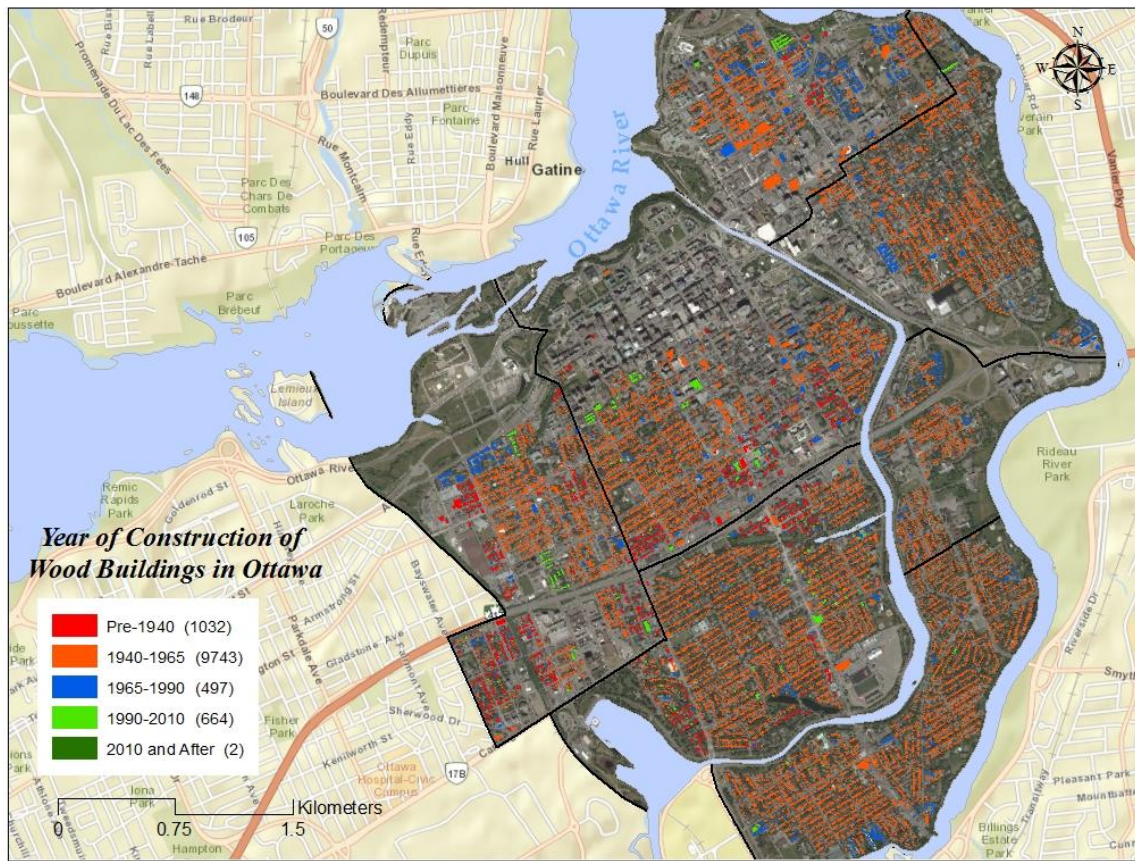

**Figure 5-5: Spatial Distribution of Year of Construction of Buildings in Ottawa, Ontario**

Lastly, the level of importance of a building, established on the basis of the building's occupancy class, can affect the level of seismic risk. As seen in Figure 5-6, more than 90% of the light wood frame buildings in the city of Ottawa are single family or multi-family dwellings, representing normal importance buildings.

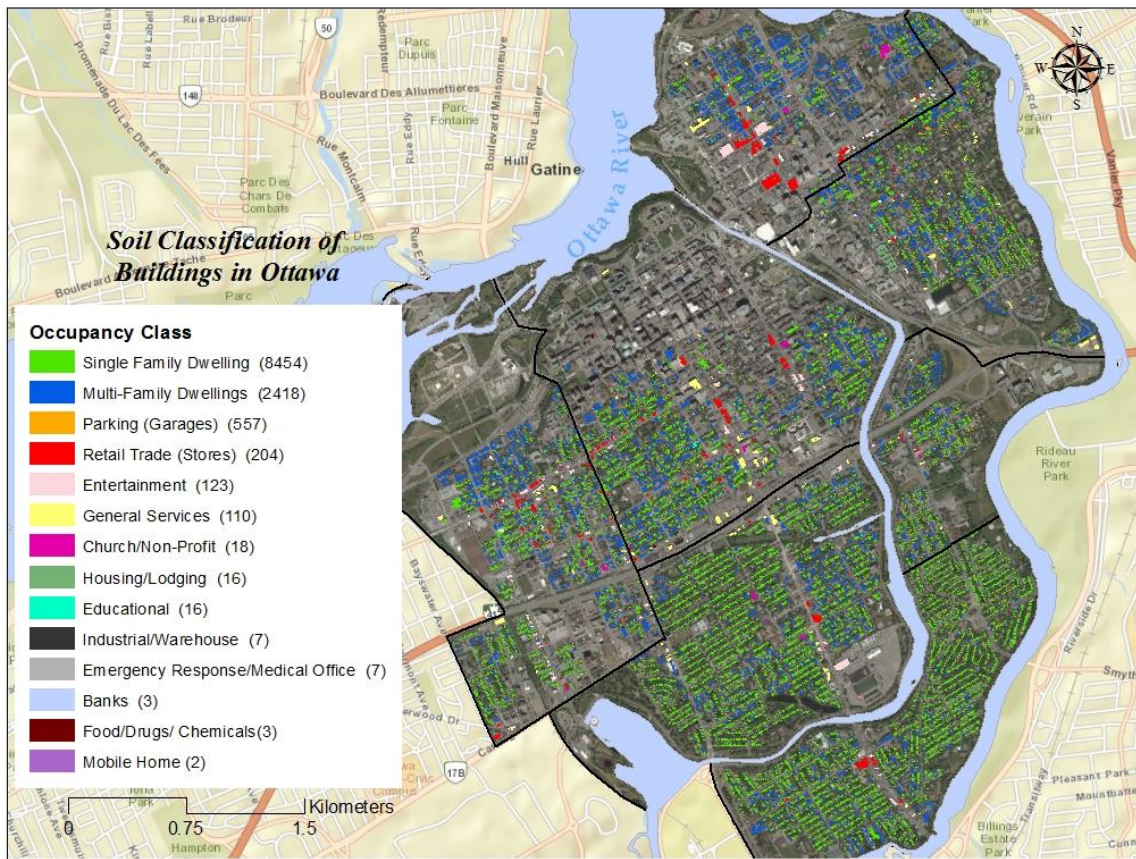
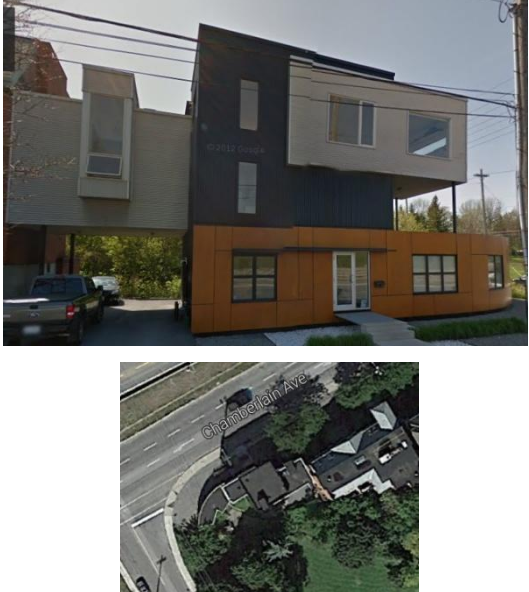
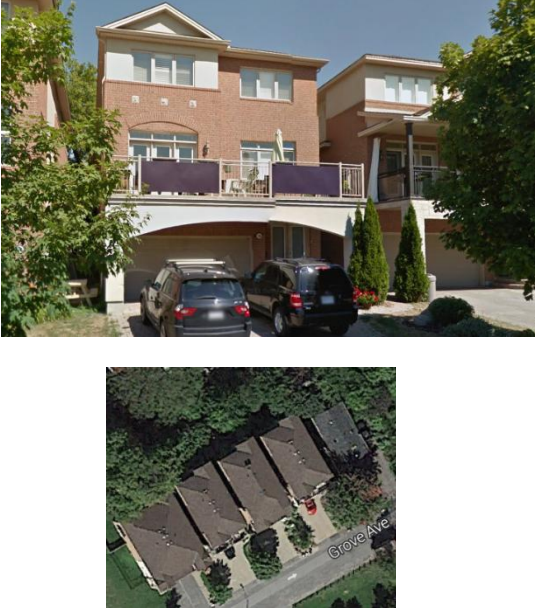



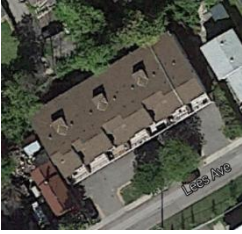



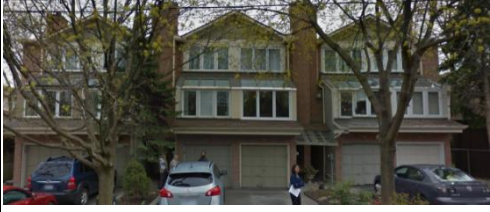



**Figure 5-6: Spatial Distribution of Year of Construction of Wood Framed Buildings in Ottawa, Ontario**

### 5.3 Case Study

Twelve light wood frame buildings, located in various parts of the city of Ottawa, were selected to run a detailed seismic risk assessment using CanRisk. Based on visual inspection and the historical fire insurance plans, the buildings were verified as being of light wood frame construction. Photos of the selected buildings under assessment are provided using Google Map and Google Street View and presented in Table 5-1.

**Table 5-1: Photos of the Light Wood Frame Buildings under Investigation**  
 (Photos Provided by Google Map and Google Street View)

#	Photo	#	Photo
1		2	
3		4	

<p>5</p>	 	<p>6</p>	 
<p>7</p>	 	<p>8</p>	 
<p>9</p>	 	<p>10</p>	 

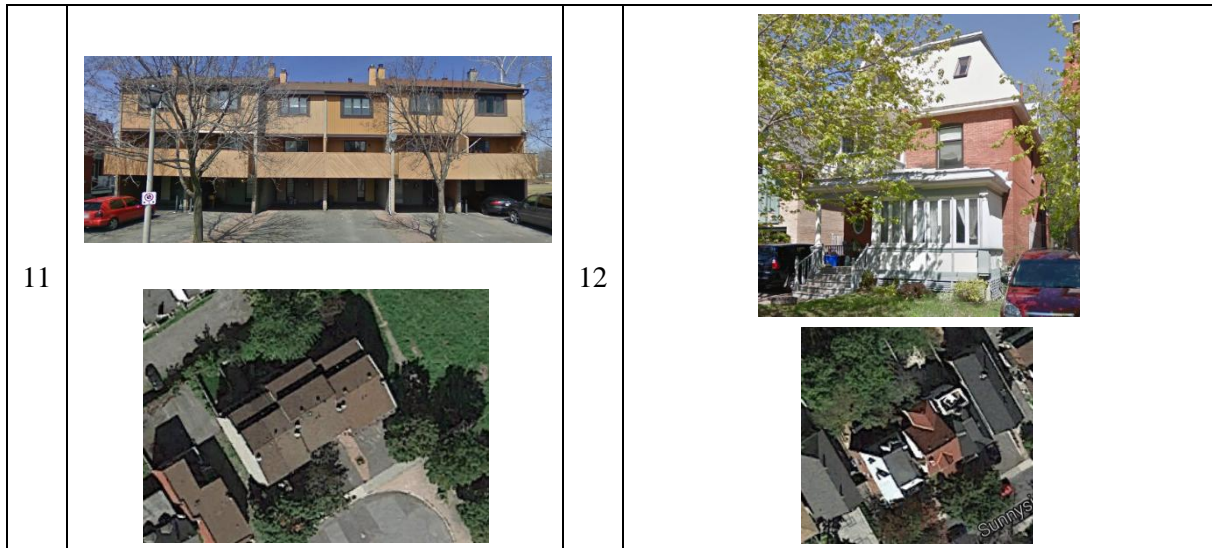

To select the input parameters (performance modifiers) used in CanRisk for the buildings under investigation, a site visit was conducted to each building to evaluate the building configuration, number of stories, building use, economic impact, vertical irregularity, plan irregularity, construction quality, falling hazards to life and hazards to vital operations. Also, the fire insurance plans, provided from the City of Ottawa, and the GIS information were used to determine the year of construction of the buildings. The occupied area of the buildings is computed by calculating the area of the buildings' footprint, using the GIS software, and multiplying the computed area by the number of stories. Using the available microzonation maps for the city of Ottawa (Motazedian et al., 2011), the soil types were identified. Finally, the spectral acceleration  $S_a(T1)$  was computed using the procedure outlined in NBCC 2010 by considering the selected soil type, the empirical formulas to determine building period, and the corresponding seismic data for Ottawa, Ontario. The collected data is summarized in Table 5-2.

As seen in Table 5-2, the buildings have various conditions in terms of the main parameters affecting the level of building damageability. In sample number 1, the year of construction, soil type, and the plan irregularity of the building are mainly focused in the assessment. In sample 2, while the building is newer than the rest, having both types of irregularities is what makes it suitable for the assessment. In building 3, the building has a bad condition in terms of critical parameters, including the year of construction, the sheathing product, and the soil type. In buildings 5 and 6, the damageability of the same type of wood-framed building, built

on different soil types, having a different occupancy area, year of construction, level of irregularity, and also level of non-structural hazard, is compared. Building 7 has a high level of plan irregularity but the rest of the structural parameters are in good condition. In building 8, the building use is varied. In buildings 9 and 10, the effect of different sheathing products, year of construction, and also the level of vertical irregularity is compared. In buildings 11 and 12, the sheathing products are varied.

**Table 5-2: Summary of Input parameters (performance modifiers) for buildings under investigation**

Building Number	Building Type	Number of Stories	Soil Type	Spectral Acceleration (g)	Building Use	Building Area (m <sup>2</sup> )	Economic Impact	Vertical Irregularity	Plan Irregularity	Year of Construction	Construction Quality	Falling Hazard to Life	Hazard to Vital Operation
1	LF-NENG-WBW	4	E	0.707	AP	839	NG	VL	H	1920	AV	M	VL
2	LF-ENG-WSP	2	D	0.71	D	132	NG	M	M	2000	GD	VL	VL
3	LF-NENG-GWB	2	D	0.71	D	164	NG	H	L	1940	AV	VL	VL
4	LF-ENG-WSP	3	C	0.52	D	160	NG	H	VL	1970	GD	L	VL
5	LF-NENG-WBW	3	D	0.623	D	97	NG	H	VL	1940	AV	H	VL
6	LF-NENG-WBW	3	B	0.42	D	807	NG	VH	VL	1960	AV	VL	VL
7	LF-ENG-WSP	4	A	0.275	D	235	NG	L	H	1995	AV	M	VL
8	LF-ENG-WSP	4	D	0.542	GH	1024	NG	VL	H	1985	GD	L	VL
9	LF-NENG-WBW	3	D	0.623	D	361	NG	H	VL	1970	GD	M	VL
10	LF-NENG-WSP	3	D	0.623	D	363	NG	L	VL	1990	AV	L	VL
11	LF-NENG-DL	3	C	0.521	D	400	NG	VH	VL	1983	GD	VL	VL
12	LF-NENG-DNA	3	D	0.623	D	123	NG	M	VL	1940	AV	M	VL

LF = Light Frame, ENG = Engineered, NENG = Non-Engineered, WSP = Wood Structural Panel, WBW = Wood Based Wallboard, DL = Diagonal Lumber, GWB = Gypsum Wallboard, DNA = Details Not Available,  
 VL = Very Low, L = Low, M = Moderate, H = High, VH = Very High, NG = Negligible, GD = Good, AV = Average, PR = Poor, AP = Apartment, D = Dwelling, GH = Group Housing

The results of CanRisk seismic risk assessment of the selected buildings using the aforementioned building data, is summarized in Table 5-3. Regarding the structural damage, while some buildings show *heavy* damage, the majority of the light wood frame buildings in this case study show *light to moderate* structural damage. Three buildings (building 1, 2 and 3 of Table 5-3) were classified as *heavy*. In building 1, although the structural vulnerability is *low*, the building is experiencing a *heavy* structural damage. This is due to the high spectral acceleration resulted from the soft soil of the site where the building is constructed. The main reason for the high level of building damageability in building 2 is the level of the plan and vertical irregularities in this building and the poor quality of soil type. In building 3, most of the elements affecting structural damageability are in a very bad condition, especially the quality of the sheathing product used. This high level of building damageability consequently resulted in a *critical* level of structural risk for the building. In building 8, while the results are showing a *moderate* structural damage, the level of structural risk is *critical*. This is mainly due to the high number of occupants in this building and the size of the occupied area which directly affect the level of building importance.

The analysis based on non-structural assessment shows that most light wood frame buildings examined in this case study are expected to have *none to light* non-structural damage, with just one experiencing *moderate* non-structural damage.

Considering overall building risk, the light wood frame buildings in this case study are facing either *negligible* or *marginal* level of seismic risk, even though some of them are experiencing a critical level of structural risk. This is attributed to the building significance in terms of economic impact. They are typically small dwellings, with few occupants. Still, the information provided from the detailed risk assessment presented in this section demonstrates the potential damageability of old and irregular light wood frame buildings and the need for the seismic retrofitting of the structural and non-structural elements of these building.

**Table 5-3: Summary of Results of Buildings under Investigation**

Building Number	Structural Assessment						Non-Structural Assessment						Overall Building Risk	
	Structural Vulnerability Index	Structural Vulnerability	Structural Damage Index	Structural Damage	Structural Risk Index	Structural Risk	Non-Structural Vulnerability Index	Non-Structural Vulnerability	Non-Structural Damage Index	Non-Structural Damage	Non-Structural Risk Index	Non-Structural Risk	Overall building risk index	Overall building risk
1	0.39	L	0.64	HV	0.38	Marg	0.24	L	0.25	LT	0.08	NG	0.25	Marg
2	0.44	M	0.68	HV	0.4	Marg	0.08	VL	0.19	N	0.09	NG	0.25	Marg
3	0.58	M	0.76	HV	0.52	Crit	0.15	VL	0.23	LT	0.09	NG	0.37	Marg
4	0.56	M	0.37	LT	0.22	Marg	0.08	VL	0.19	N	0.08	NG	0.18	NG
5	0.56	M	0.55	M	0.3	Marg	0.59	M	0.6	M	0.34	Marg	0.33	Marg
6	0.63	H	0.38	LT	0.22	Marg	0.28	L	0.29	LT	0.15	NG	0.19	NG
7	0.42	M	0.25	LT	0.08	NG	0.34	L	0.25	LT	0.08	NG	0.09	NG
8	0.32	L	0.41	M	0.48	Crit	0.09	VL	0.2	N	0.24	Marg	0.34	Marg
9	0.5	M	0.54	M	0.29	Marg	0.34	L	0.35	LT	0.2	NG	0.22	Marg
10	0.08	VL	0.3	LT	0.16	NG	0.09	VL	0.2	N	0.08	NG	0.11	NG
11	0.58	M	0.38	LT	0.22	Marg	0.09	VL	0.2	N	0.08	NG	0.18	NG
12	0.56	M	0.55	M	0.3	Marg	0.37	L	0.37	LT	0.22	Marg	0.23	Marg

VL = Very Low, L = Low, M = Moderate, H =High, VH = Very High, NG = Negligible, N =None, Marg = Marginal, Crit = Critical, CC = Catastrophic Consequences, LT = Light, HV = Heavy, Col = At/Near Collapse,

# Chapter 6

## Summary, Conclusion and Future Recommendations

---

### 6.1 Summary

Past earthquakes have demonstrated seismic vulnerabilities of existing wood-framed buildings with deficiencies particularly stemming from lack of engineering design, older design codes with inadequate seismic regulations, and poor construction practices. In Canada, a large proportion of these older buildings are still operational and have not been retrofitted. Therefore, they remain at risk in the event of a large magnitude earthquake and may require to be further assessed and upgraded to minimize seismic damage. To identify the critical wood-framed buildings and prioritize their retrofitting needs, a seismic risk assessment model is required.

In this thesis a risk-based visual seismic assessment model and a seismic risk assessment tool (CanRisk) are presented, to assess seismic vulnerabilities of existing wood frame construction and identify those that are seismically deficient. The tool determines the overall building risk through structural and non-structural assessment by considering three main modules: site seismic hazard, building vulnerability, and importance and exposure of the building. In the proposed seismic assessment model used in CanRisk, fuzzy logic is used to capture the vagueness and uncertainty of a seismic vulnerability assessment conducted in a walk down survey. The hierarchical fuzzy rule base modeling used in this seismic assessment method is implemented in a prototype Matlab based program.

The proposed model was tested and verified using a sensitivity analysis. Also, to demonstrate the applicability of the software, a seismic risk assessment was conducted on a number of buildings in the city of Ottawa, an area of moderate seismic risk, using CanRisk. In addition, using the data collected by UrbanRAT tool, a summary of the building data collected specifically for the seismic risk assessment of existing wood-framed buildings in the city of Ottawa, is presented by spatial distribution maps and percentage breakdowns.

## 6.2 Conclusion

The following conclusions can be drawn based on the current research study:

- Seismic risk assessment of the existing buildings can be fast, simple, and at the same time very effective in management and mitigation of the earthquake risk, using the new assessment methods and tools such as CanRisk,
- The hierarchical risk analysis of wood frame construction is a simple technique for prioritization of wood-framed buildings,
- The fuzzy set theory implemented in the hierarchical structure was capable of assessing the uncertainty caused by subjective judgment involved in the vulnerability evaluation of the buildings,
- There is a large number of non-engineered wood-framed buildings in Canada which were constructed prior to any seismic code adoptions, as illustrated by the data of the wood-framed buildings collected for the city of Ottawa. This indicates the need for seismic risk assessment of this type of construction in Canada,
- The detailed seismic assessment (structural and non-structural) conducted on 12 wood-framed buildings in the city of Ottawa illustrates *light to moderate* damageability of wood-framed buildings, although in the worst case scenarios (old buildings, covered with weak sheathing, and with high irregularities) this damageability can reach *heavy* level,
- The evolution of code requirements, design and detailing standards, and also the construction materials of wood frame construction in Canada, have enormously enhanced its seismic performance, so it can be expected that modern wood framed buildings, resist damaging effects of earthquake ground motions much better than before. More recent wood-framed buildings, especially engineered ones using plywood shear walls, should perform well.

## 6.3 Future Recommendations

The following recommendations can be made for further studies based on the research presented in this thesis:

- To complete the structural systems incorporated in the CanRisk tool, seismic risk assessment of steel structures should be added.
- The scope of CanRisk may be expanded to include other natural hazards such as landslide, hurricane, or tornado.
- Estimation of casualties, injuries and economic losses should be included as future research project.
- CanRisk can be integrated into a geographical information system (GIS) platform and also Google Map and Google Street View to enable the user to have easier access to the building data.

## References

---

- Adams, J., & Atkinson, G. (2003). "Development of seismic hazard maps for the proposed 2005 edition of the National Building Code of Canada." *Canadian Journal of Civil Engineering*, 30:255–271.
- Adams, J., and Atkinson, G. (2003). "Development of seismic hazard maps for the proposed 2005 edition of the National Building Code of Canada." *Canadian Journal of Civil Engineering*, 30:255–271.
- Allen, D.E, & Rainer, J.H (1993) "Guidelines for the seismic evaluation of existing buildings" *Canadian Journal of Civil Engineering*, 22: 500-505.
- APA (1997). *Design Concepts: Building in High Wind and Seismic Zones*. The Engineered Wood Association, Tacoma, WA.
- APA (2003). *Introduction to Lateral Design*. The Engineered Wood Association, Tacoma, WA.
- ASCE (1998). *Handbook for the Seismic Evaluation of Buildings-A Prestandard*. Prepared by American Society of Civil Engineers, published by the Federal Emergency Management Agency, (FEMA 310 report), Washington, D.C.
- ATC (1997). *NEHRP Guidelines for the Seismic Rehabilitation of Buildings*. Prepared by the Applied Technology Council, for Building Seismic Safety Council, with funding by the Federal Emergency Management Agency, (FEMA 273 report), Washington, D.C.
- ATC (2002). *Rapid Visual Screening of Buildings for Potential Seismic Hazard: A Handbook. (Second edition)*. Prepared by the Applied Technology Council, published by the Federal Emergency Management Agency, (FEMA 154 report), Washington, D.C.
- ATC (2011). *Reducing the Risks of Nonstructural Earthquake Damage – A Practical Guide*. Prepared by the Applied Technology Council, published by the Federal Emergency Management Agency, (FEMA E-74) report, Washington, D.C.
- ATC (2012). *Seismic evaluation and retrofit of multi-unit wood-frame buildings with weak first stories*. Prepared by the Applied Technology Council, published by the Federal Emergency Management Agency, (FEMA P-807 report), Washington, D.C.
- ATC (2012). *Simplified Seismic Assessment of Detached, Single-Family, Wood-Frame Dwellings*. Prepared by the Applied Technology Council, published by the Federal Emergency Management Agency, (FEMA P-50 report), Washington, D.C.

- ATC/SEAOC (n.d.). *Built to Resist Earthquakes: Seismic Response of Wood-Frame Construction*. Briefing Paper 3. The Applied Technology Council and the Structural Engineers Association of California. Redwood City, CA.
- Atkinson, G. M. (2004). "An overview of developments in seismic hazard analysis." *In Proceedings of the 13th World Conference on Earthquake Engineering*, Vancouver, BC (pp. 1-6).
- AWC (2001). *Details for Conventional Wood Frame Construction*. American Forest & Paper Association, Washington, DC.
- Bird, J.F. and Bommer, J.J. (2004). "Earthquake losses due to ground failure." *Engineering Geology*, 75: 147–179.
- Brook, D.M. (2007). "Home Moisture Problems." Published by Oregon State University, Corvallis, OR.
- Bruneau, M. (1994). "State-of-the-art Report on Seismic Performance of Unreinforced Masonry Buildings." *ASCE Journal of Structural Engineering*. 120(1):230-251.
- BSSC (2006). *Home builders' guide to earthquake resistant design and construction*. Prepared by the Building Seismic Safety Council, Published by the Federal Emergency Management Agency, (FEMA 232 report), Washington, D.C.
- Carreño, M.L., Cardona, O.D., and Barbat A.H. (2008) "Application and Robustness of the Holistic Approach for the Seismic Risk Evaluation of Megacities" In: *The 14<sup>th</sup> World Conference on Earthquake Engineering, Beijing, China*.
- Cassidy, J.F., Rogers, G.C., Lamontagne, M., Halchuk, S., and Adams, J., (2010). "Canada's earthquakes: The good, the bad, and the ugly." *Geoscience Canada*, v. 37, p. 1-16.
- Charles, S., (2005). *History of Risk Model Development*.
- CMHC (1999). *Building Technology - Wood Frame Envelopes*. Canada Mortgage and Housing Corporation, Ottawa, ON.
- CMHC (2002). *Earthquake Resistant Housing: A Wood-Frame Building Performance Fact Sheet*. Canada Mortgage and Housing Corporation, Ottawa, ON.
- CMHC (2013). *Canadian Wood Frame House Construction*. Canada Mortgage and Housing Corporation, Ottawa, ON.
- Coburn, A., & Spence, R. J. (2002). *Earthquake Protection*. Chichester: Wiley.
- Crespell, P., & Gagnon, S. (2010). "Cross Laminated Timber: A Primer" FPIInnovations, Ottawa, ON.

- Cross Laminated Timber in British Columbia (2012). FPInnovations, naturally:Wood, Wood-Works, & BCWood. Retrieved from <http://www.naturallywood.com/sites/default/files/CLT-and-Dowling-Residence.pdf>
- CSA (1959). *Engineering Design in Wood, CAN/CSA- O86: A National Standard of Canada*. Canadian Standards Association. Mississauga, ON.
- CSA (1989). *Engineering Design in Wood, CAN/CSA- O86: A National Standard of Canada*. Canadian Standards Association. Mississauga, ON.
- CSA (2009). *Engineering Design in Wood, CAN/CSA- O86: A National Standard of Canada*. Canadian Standards Association. Mississauga, ON.
- CUREE (2010) *General Guidelines for the Assessment and Repair of Earthquake Damage in Residential Woodframe Buildings*. Published by Consortium of Universities for Research in Earthquake Engineering, Richmond, CA.
- CWC (2002). *Wood-Frame Housing –A North American Marvel*. Building Performance Series No. 4: Canadian Wood Council. Ottawa, ON.
- CWC (2003). *Wood-Frame Construction Meeting the Challenges of Earthquakes*. Building Performance Series No. 5: Canadian Wood Council. Ottawa, ON.
- CWC (2009). *Engineering Guide for Wood Frame Construction*. Canadian Wood Council, Ottawa, ON.
- EERI (2006). *Designing for Earthquakes: A Manual for Architects*. Prepared by the Earthquake Engineering Research Institute, published by the Federal Emergency Management Agency, (FEMA 454) report, Oakland, CA.
- Elsabbagh, A. (2013). “Seismic Risk Assessment of Unreinforced Masonry Buildings Using Fuzzy Based Techniques and the Regional Seismic Risk Assessment of Ottawa, Ontario” Master’s thesis, University of Ottawa, Ottawa, Ontario.
- Erikson, R.G., Schmidt, R.J. (2003). “Behavior of Traditional Timber Frame structures Subjected to Lateral Load” Research Project, University of Wyoming, Laramie, WY.
- Falk, R.H., & Soltis, L.A. (1998) “Seismic Behavior of Low-Rise Wood-Framed Buildings.” *The Shock and Vibration Digest*, 20 (12).
- FEMA 74 (1994). *Reducing the Risks of Nonstructural Earthquake Damage: A Practical Guide*, Third Edition. Prepared by Wiss, Janey, Elstner Associates, Inc. for the Federal Emergency Management Agency, Washington, D.C

- FEMA-249 (1994). Assessment of the State-of-the-Art Earthquake Loss Estimation Methodologies.
- FEMA (2006). *Techniques for the Seismic Rehabilitation of Existing Buildings*. Published by the Federal Emergency Management Agency, (FEMA 547 report), Washington, D.C.
- FEMA (2011). *Hazus®-MH MR5: Multi-hazard Loss Estimation Methodology: Earthquake Model*. Published by the Federal Emergency Management Agency, Washington, D.C.
- Fowler, P. (1998). “Common Construction Defects: A guided tour through some of the most common errors and omissions fueling the litigation frenzy in the California building industry” Retrieved from <http://www.certifiedriskmanagers.com/10CDs.pdf>
- Graf, W.P (2008). “The Shakeout Scenario, Supplemental Study: Woodframe Buildings” Prepared for United States Geological Survey and California Geological Survey, Los Angeles, CA.
- Graf, W.P, & Seligson, A. (2011) “Earthquake Damage to Wood-Framed Buildings in the ShakeOut Scenario” *Earthquake Spectra*, 27(2): 351–373.
- Gulati, B. (2006). “Earthquake Risk Assessment of Buildings: Applicability of HAZUS in Dehradun, India” Master’s thesis, the International Institute for Geo-information Science and Earth Observation, Netherland.
- Heavy Timber Frame Construction, (n.d.). Faculty of Engineering Memorial University, St. John's, NL. Retrieved from <http://www.engr.mun.ca/~swamidas/Notes5for>, [accessed 27 MAY 2013].
- Heidebrecht, A. C. (2003). “Overview of seismic provisions of the proposed 2005 edition of the National Building Code of Canada.” *Canadian Journal of Civil Engineering*, 30(2), 241-254.
- Hendricks, j. (2009). “Timber Frame vs. Post and Beam Construction” Architect AIA, Retrieved from <http://hendricksarchitect.com/architecture/timber-frame-vs-timber-post-and-beam-construction> [accessed 27 Sep 2013].
- Hunter, J. A., Crow, H. L., Brooks, G. R., Pyne, M., Motazedian, D., Lamontagne, M., Pugin, A. J. –M., , Pullan, S. E., Cartwright, T., Douma, M., Burns, R. A., Good, R. L., Kaheshi- Banab, K., Caron, R., Kolaj, M., Folahan, I., Dixon, L., Dion, K., Duxbury, A., Landriault, A., Ter-Emmanuel, V., Jones, A., Plastow, G., and Muir, D. (2010). “Seismic site classification and site period mapping in the Ottawa area using geophysical methods.” Geological Survey of Canada. Open file 6273. pp. 80.

- Kalman, H., & Roaf, J. (1978). "Exploring Vancouver 2- Ten Tours of the City and Its Buildings." UBC Press, Vancouver, B.C.
- Kharrazi, M.H.K., Ventura, C.E., Prion, H.G.L., Taylor G.W., Lord J.F., & Turek, M. (2002). "Experimental evaluation, of Seismic Response of Wood Frame Residential Construction" In: *4<sup>th</sup> Structural Specialty Conference of the Canadian Society for Civil Engineering, Montréal, QC*.
- KLH Gmbh (2010). "Cross Laminated Timber" Retrieved from <http://crosslaminatedtimber.net> [accessed 23 Feb 2014].
- Kovacs, P. (2010). "Reducing the risk of earthquake damage in Canada: Lessons from Haiti and Chile". Published by Institute for Catastrophic Loss Reduction, Toronto, Ontario.
- Lamontagne, M. (2010). "Historical Earthquake Damage in the Ottawa-Gatineau Region." *Seismological Research Letters*, NRC. 81(1):129-139.
- Law, K.K. (2012). "Five-story wood structure that uses CLT, glulam, and LSL." Photo Retrieved from <http://continuingeducation.construction.com/crs.php?L=324&C=946> [accessed 20 Feb 2014].
- Mamdani, E.H. (1977). "Application of fuzzy logic to approximate reasoning using linguistic Synthesis." *IEEE Transactions on Computers*, 26(12): 1182–1191.
- MathWorks, Inc, Jang, J.S.R., & Gulley, N. (1997). "Fuzzy Logic Toolbox: for Use with MATLAB: User's Guide; Version 1; Computation, Visualization, Programming." Published by MathWorks, Incorporated.
- Mitchell, D., Paultre, P., Tinawi, R., Saatcioglu, M., Tremblay, R., Elwood, K., & DeVall, R. (2010). "Evolution of seismic design provisions in the National building code of Canada." *Canadian Journal of Civil Engineering*, 37(9), 1157-1170.
- Motazedian, D., Hunter, J., Pugin, A., Crow, H. (2011). "Development of a Vs30 (NEHRP) Map for the City of Ottawa, Ontario, Canada." *Canadian Geotechnical Engineering Journal*. 48: 458–472.
- NIBS (2006). *NEHRP Recommended Provisions: Design Examples*. Prepared by the National Institute of Building Sciences Building Seismic Safety Council, Published by the Federal Emergency Management Agency, (FEMA 451 report), Washington, D.C.
- NIBS (2010). *Earthquake-Resistant Design Concepts*. Prepared by the National Institute of Building Sciences Building Seismic Safety Council, published by the Federal 10. District of North Vancouver Heritage Inventory, The Corporation of North Vancouver

- North V. (1993). "District of North Vancouver Heritage Inventory, the Corporation of North Vancouver." Prepared by Commonwealth Historic Resource Management Limited, Vancouver, BC, Emergency Management Agency, (FEMA P-749 report), Washington, DC.
- NRCC (1970). *National Building Code of Canada*. Associate Committee on the National Building Code, National Research Council of Canada, Ottawa, ON.
- NRCC (1975). *National Building Code of Canada*. Associate Committee on the National Building Code, National Research Council of Canada, Ottawa, ON.
- NRCC (1990). *Commentary of Part 9 National Building Code of Canada*. Canadian Commission on Building and Fire Codes, National Research Council of Canada, Ottawa, ON.
- NRCC (1993). *Guidelines for the seismic evaluation of existing buildings*. Prepared by Institute for Research in Construction of the National Research Council Canada, Ottawa, ON.
- NRCC (1993). *Manual for Screening of Buildings for Seismic Investigation*. Prepared by Institute for Research in Construction of the National Research Council Canada, Ottawa, ON.
- NRCC (2005). *National Building Code of Canada*. Associate Committee on the National Building Code, National Research Council of Canada, Ottawa, ON.
- NRCC (2010). *National Building Code of Canada*. Associate Committee on the National Building Code, National Research Council of Canada, Ottawa, ON.
- NZSEE (2006). *Assessment and Improvement of the Structural Performance of Buildings in Earthquakes*. Published by the New Zealand Society for Earthquake Engineering.
- Otani, S. (2000). Seismic vulnerability assessment methods for buildings in Japan. *Earthquake Engineering and Engineering Seismology*, 2(2), 47-56.
- Park, S., & van de Lindt, J.W. (2010). "Formulation of Seismic Fragilities for a Wood-Frame Building Based on Visually Determined Damage Indexes" *Journal of Performance of Constructed Facilities*, pp. 346-352.
- Rainer, J. H., D. E. Allen, and A. M. Jablonski. (1992). *Manual for Screening of Buildings for Seismic Investigation*. Published by the National Research Council Canada of Canada, Ottawa, Ontario.

- Rainer, J.H., & Karacabeyli, E. (2000). "Performance of Wood-Frame Construction in Earthquakes." In: *12<sup>th</sup> World Conference on Earthquake Engineering, Auckland, New Zealand*.
- Rainer, J.H., Lepper, P., & Karacabeyli, E. (2000) "Ensuring good seismic performance with platform frame wood housing" Construction Technology Updates No.45. Published by Institute for Research in Construction, National Research Council of Canada, Ottawa, ON.
- Rainer, J.H., Lepper, P., & Karacabeyli, E. (2004) "Seismic Performance of Wood-Frame Buildings." In: *13<sup>th</sup> World Conference on Earthquake Engineering, Vancouver, B.C.*
- Riverbend Timber Framing, (2014). "Master Bath". Photo. *riverbendtf.com*. Retrieved from <http://www.riverbendtf.com/photo-gallery/index.php?level=picture&id=184> [accessed 15 March 2014].
- Ricci, P.F., Sagen, L.A., & Whipple, C.G. (1981). "Technological Risk Assessment Series" *E: Applied Series No.81*.
- Rojhan, C., & Eguchi, E.t. (2000). "ATC-50, Seismic Grading and Retrofitting Project for Detached Single Family Wood-Frame Dwellings." In: *12<sup>th</sup> World Conference on Earthquake Engineering, Auckland, New Zealand*.
- Ross, T.J. (2010). *Fuzzy logic with Engineering Applications. Third Edition*. John Wiley & Sons. UK.
- Saatcioglu, M., and Humar, J. (2003). "Dynamic analysis of buildings for earthquake-resistant design." *Canadian Journal of Civil Engineering*, 30: 338–359.
- Saatcioglu, M., Mitchell, D., Tinawi, R., Gardner, N. J., Gillies, A. G., Ghobarah, A., Anderson, D. L., and Lau, D. (2001). "The August 17, 1999 Kocaeli (Turkey) earthquake-damage to structures." *Canadian Journal of Civil Engineering*. 30, 715–737.
- Saatcioglu, M., Shooshtari, M. Foo, S. (2011). *Seismic Screening of Buildings in Canada: Based on the Canadian Seismicity as per NBCC-2005*. Published by Public Works and Government Services Canada. Gatineau, P.Q.
- Saatcioglu, M., Shooshtari, M. Foo, S. (2012). "Seismic screening of buildings based on the 2010 National Building Code of Canada" *Canadian Journal of Civil Engineering*, 40: 483–498

- Sawada, M., Ploeger, K., ElSabbah, A., Nastev, M., Saatcioglu, M., and Rosetti, E. (2013). "Integrated desktop/mobile GIS application for building inventory." *Geological Survey of Canada*, Open File 7345, 1 CD-ROM
- Schmid, B.L., Nielsen, R.J., and Linderman, R.R. (1994) "Narrow Plywood Shear Panels," *Earthquake Spectra*, *EERI*.
- Schmidt, R.J., & Erikson, R.G. (2003) "Behavior of Traditional Timber Frame Structures Subjected to Lateral Load" University of Wyoming, Laramie, WY.
- Senft, J.F. (2003). "Wood as a Construction Material" Published by CRC Press LLC.
- Sivanandam, S.N., Sumathi S., & Deepa S.N. (2007). *Introduction to Fuzzy Logic using MATLAB*. Springer-Verlag Berlin Heidelberg, New York, NY.
- Smith, K., (2001). *Environmental Hazards: Assessing Risk and Reducing Disaster*, London.
- Soltis, L.A., & Falk R.H. (1992). "Seismic Performance of Low-Rise Wood Buildings." Published by the Vibration Institute, Willowbrook, IL.
- Statistics Canada. (2011). Population of census metropolitan areas. Retrieved from [www.statcan.gc.ca](http://www.statcan.gc.ca) [accessed 27 January 2013].
- Taraschuk, C. (2011). "2010 National Model Construction Codes: Lateral Load Resistance-NBC Part 9." The National Research Council Canada, Ottawa, ON.
- Tesfamariam, S. (2008). "Seismic Risk Assessment of Reinforced Concrete Buildings Using Fuzzy Based Techniques." Master's thesis, University of Ottawa, Ottawa, Ontario.
- Tesfamariam, S. and Saatcioglu, M. (2008). "Risk-Based Seismic Evaluation of Reinforced Concrete Buildings." *Earthquake Spectra*, 24(3): 795-821.
- Tesfamariam, S. and Saatcioglu, M. (2010). "Seismic vulnerability assessment of reinforced concrete buildings using hierarchical fuzzy rule base modeling." *Earthquake Spectra*, 26(1): 235-256.
- USGS (2005) "House in the Santa Cruz Mountains, California, collapsed in the 1989 magnitude 6.9 Loma Prieta earthquake" Photo. *Structural Engineers Celebrating Earthquake Safety*. Retrieved From <http://www.celebratingeqsafety.com/different-structures-challenges> [accessed 15 March 2014].
- Ventura C.E., & Kharrazi, M.H.K. (2003). "Housing Report: Single-Family Wood Frame House." World Housing Encyclopedia Report. Published by the Earthquake Engineering Research Institute, and the International Association for Earthquake Engineering, Report Number 82.

Villacis, C.A., (1999). *Guidelines for the Implementation of Earthquake Risk Management Projects*, Palo Alto, California.

Villacis, C.A. and Cardona, C.N., (1999). *RADIUS Methodology - Guidelines for the Implementation of Earthquake Risk Management Projects*, Palo Alto, California.

Xiao, Y., Ye, J., Chen, R., Tang, M. (2012). “Research on Quantitative Model of Risk Assessment for Amusement Rides” In: *2<sup>nd</sup> International Conference on Electronic & Mechanical Engineering and Information Technology*.

Zadeh, L.A. (1965). “Fuzzy sets.” *Information Control*, 8: 338–353.

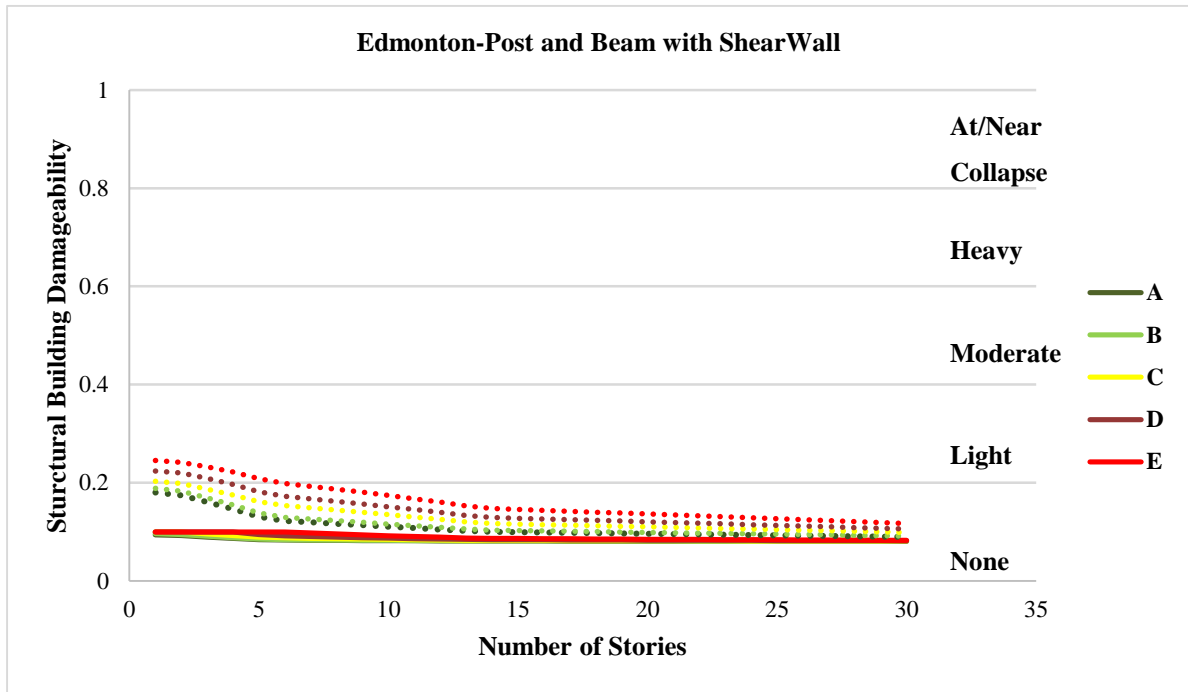

Figure A-1: Upper and lower bound limits of  $I^{BD}$  for Post and Beam structures with shearwall resting on various soil conditions in Edmonton, Alberta

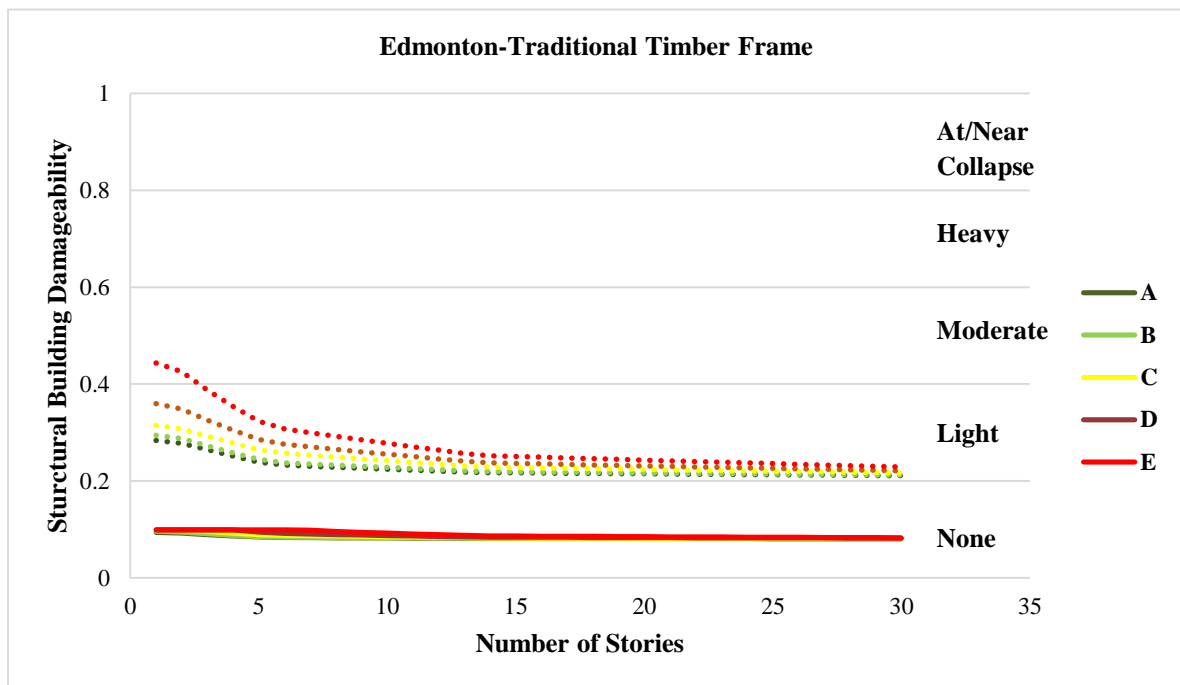

Figure A-2: Upper and lower bound limits of  $I^{BD}$  for Traditional Timber Frame structures resting on various soil conditions in Edmonton, Alberta

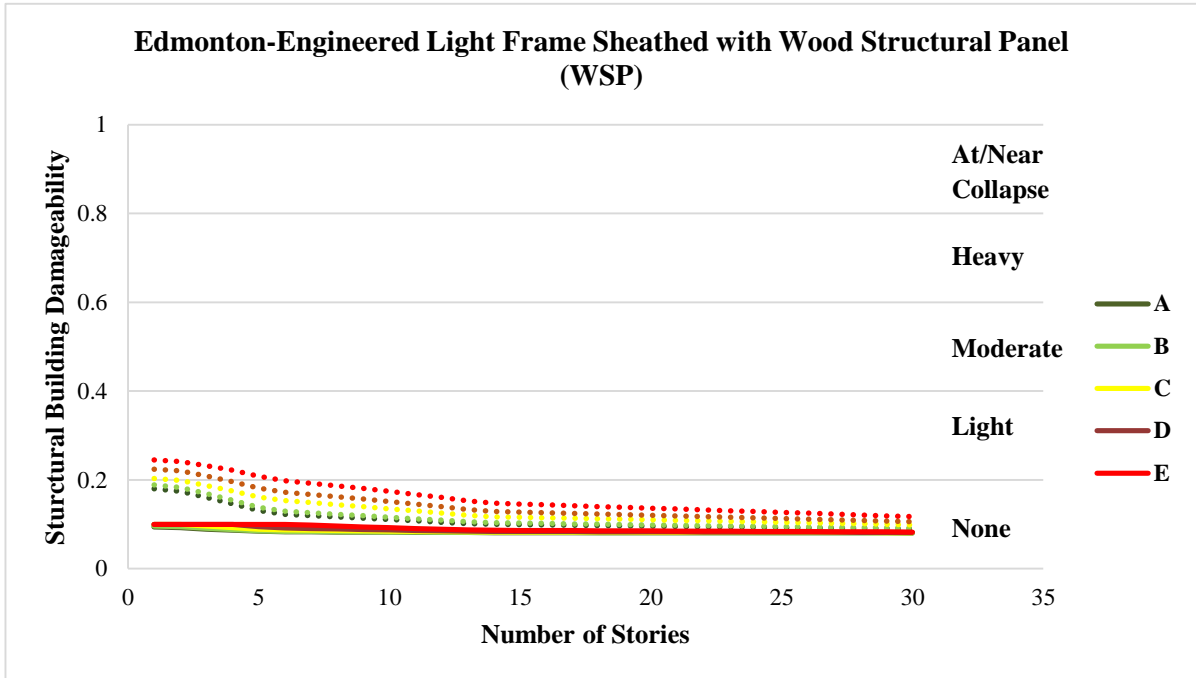

Figure A-3: Upper and lower bound limits of  $I^{BD}$  for Engineered Wood Light Frame structures sheathed with WSP resting on various soil conditions in Edmonton, Alberta

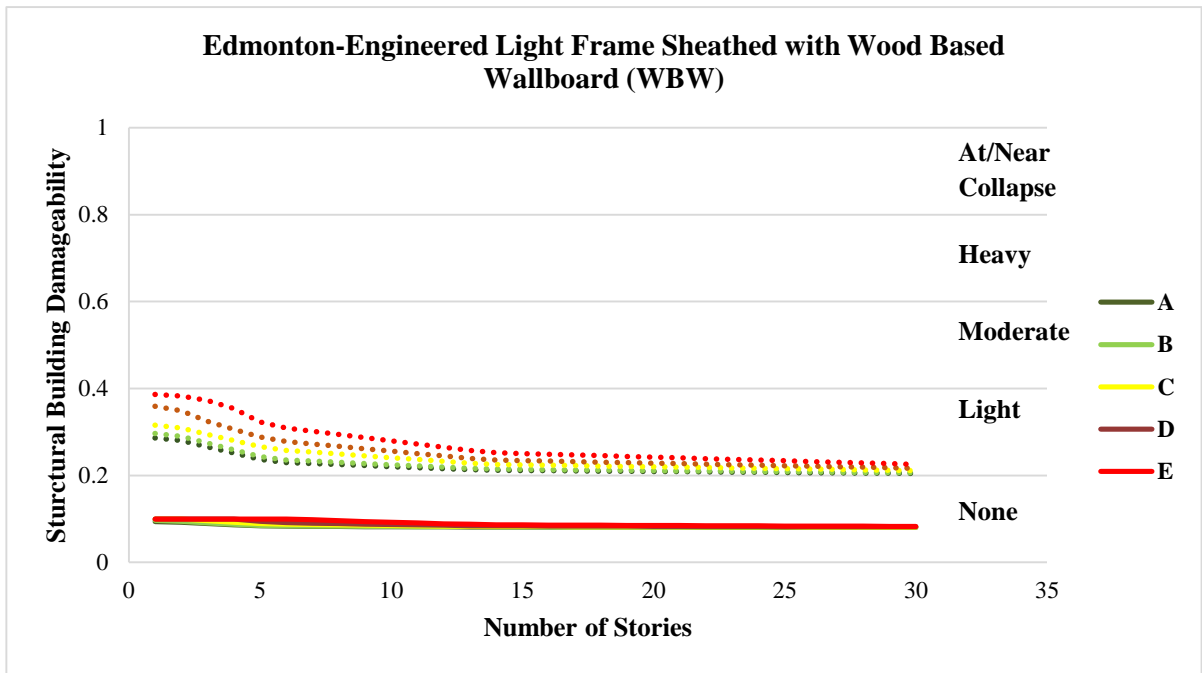

Figure A-4: Upper and lower bound limits of  $I^{BD}$  Engineered Wood Light Frame structures sheathed with WBW resting on various soil conditions in Edmonton, Alberta

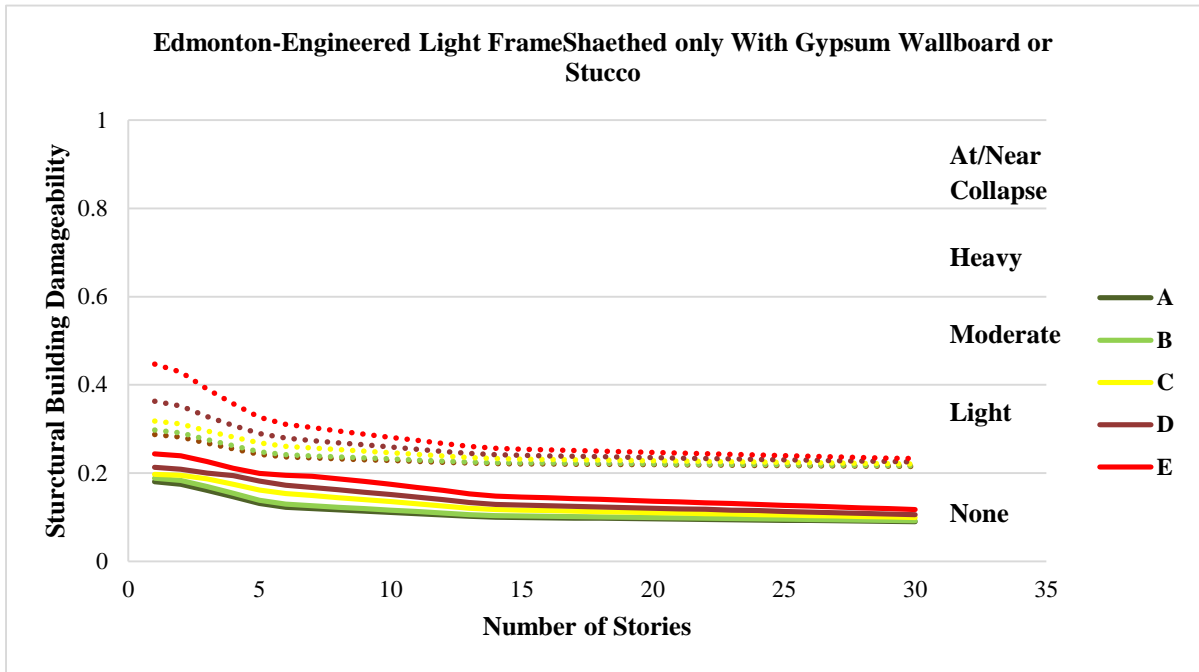

Figure A-5: Upper and lower bound limits of  $I^{BD}$  for Engineered Wood Light Frame structures sheathed only With Gypsum Wallboard or Stucco resting on various soil conditions in Edmonton, Alberta

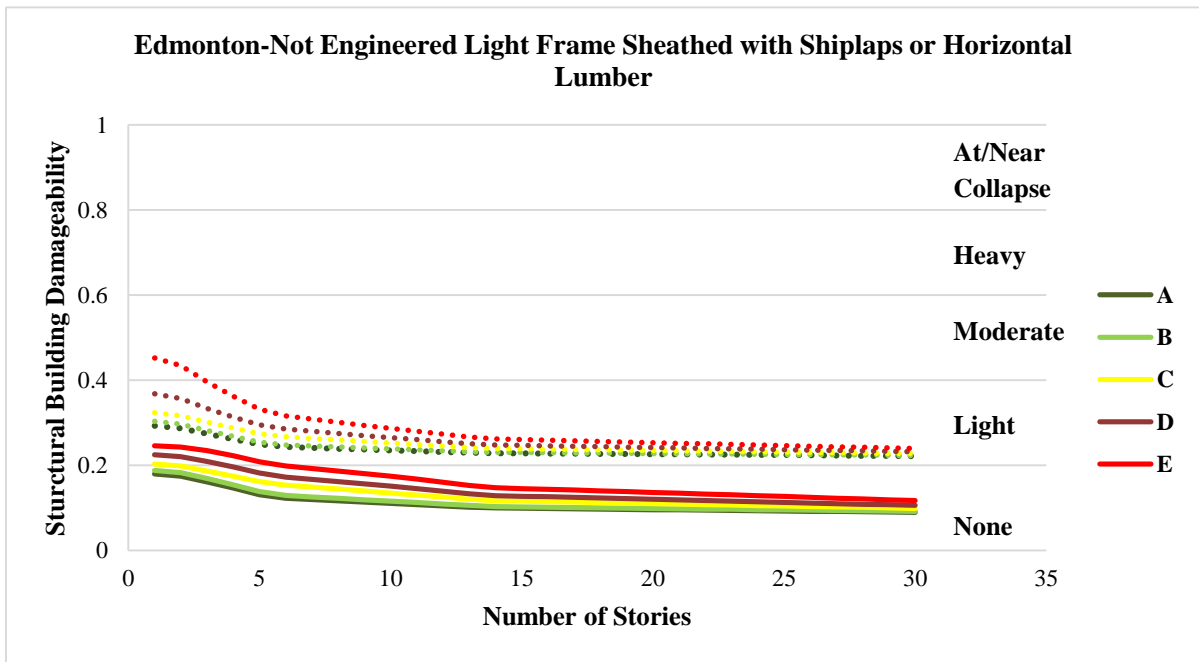
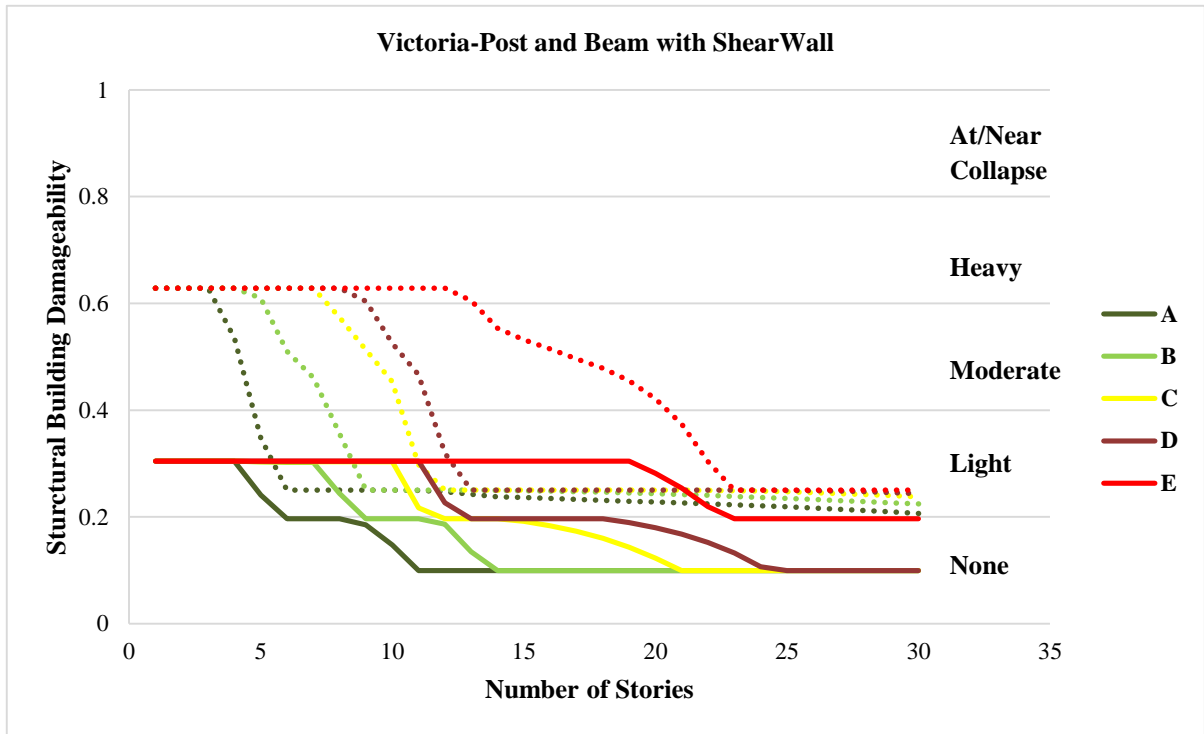
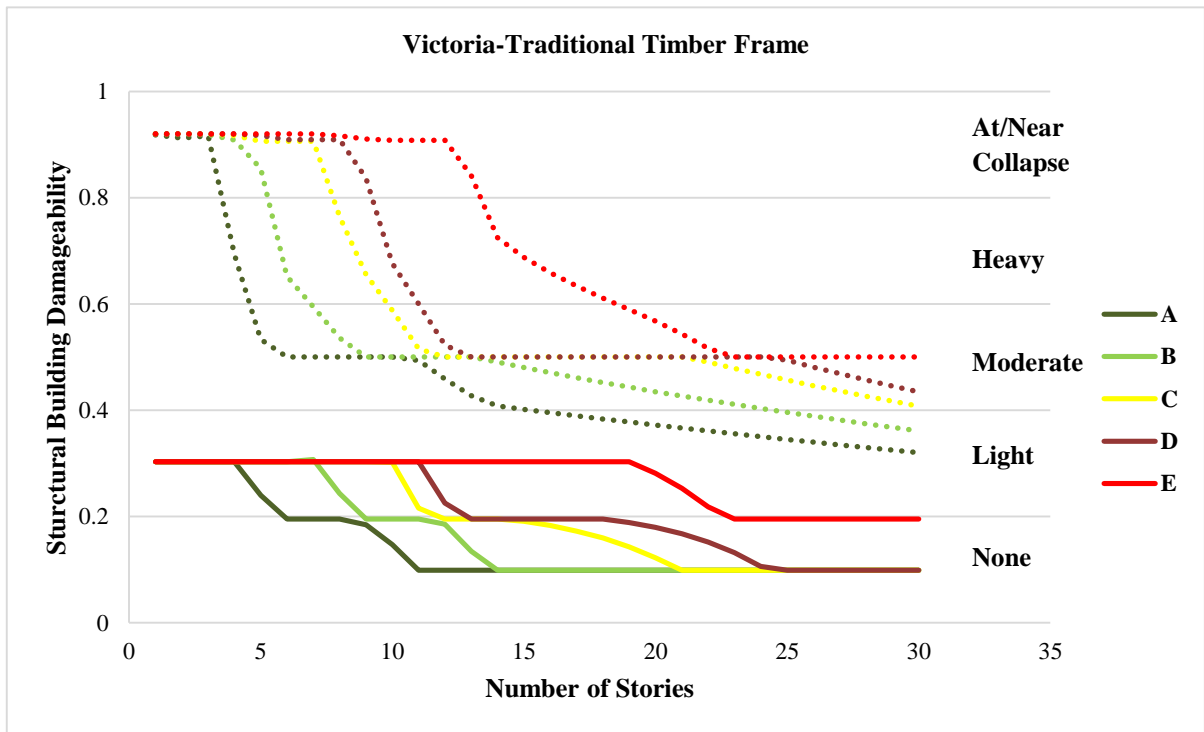

Figure A-6: Upper and lower bound limits of  $I^{BD}$  for Non- Engineered Wood Light Frame structures sheathed with Horizontal Lumber or Shiplaps resting on various soil conditions in Edmonton, Alberta



**Figure A-7: Upper and Lower Bound Limits of Building Damageability for Post and Beam Structures resting on various soil conditions in Victoria, British Columbia**



**Figure A-8: Upper and Lower Bound Limits of Building Damageability for Traditional Timber Frame Structures resting on various soil conditions in Victoria, British Columbia**

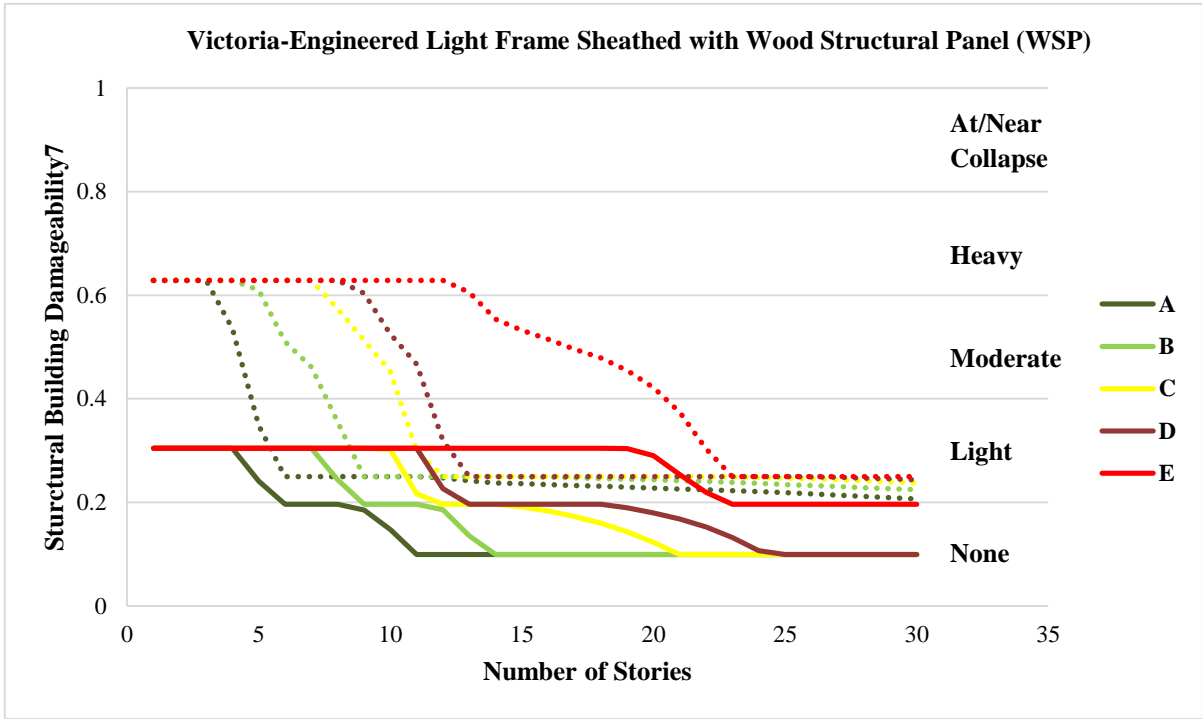

**Figure A-9: Upper and Lower Bound Limits of Building Damageability for Engineered Light Frame Structures sheathed with WSP resting on various soil conditions in Victoria, British Columbia**

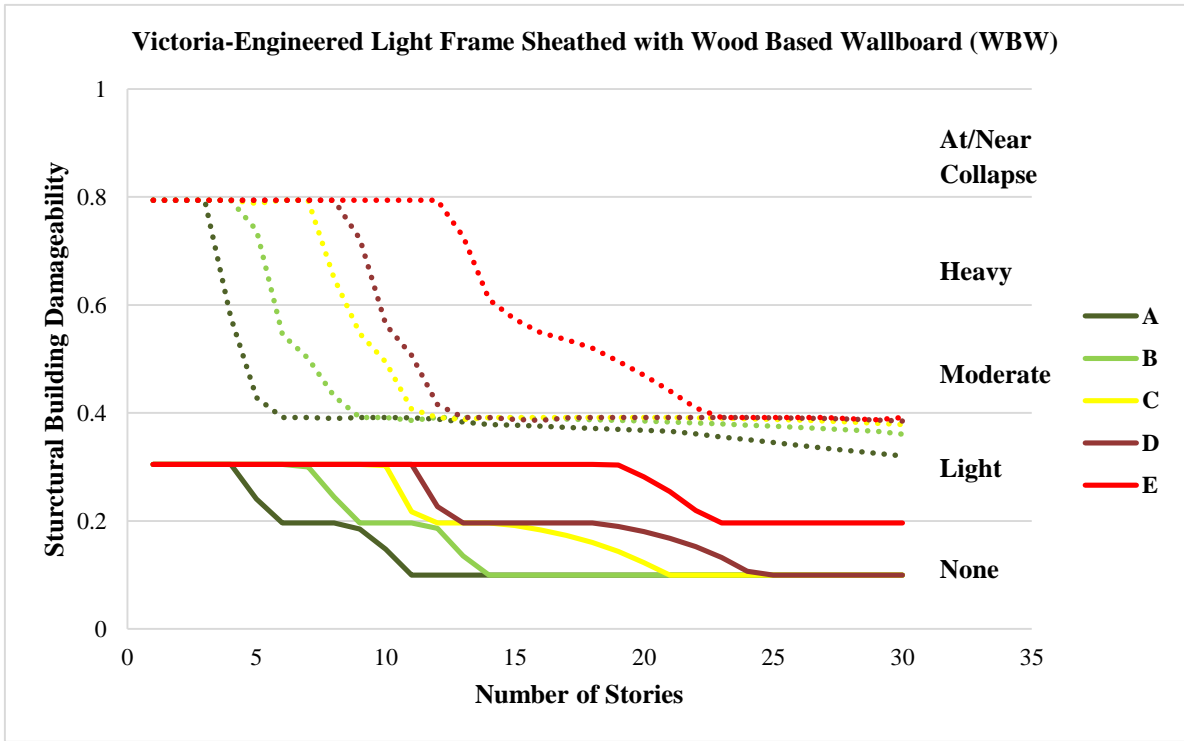

**Figure A-10: Upper and Lower Bound Limits of Building Damageability for Engineered Light Frame Structures sheathed with WBW resting on various soil conditions in Victoria, British Columbia**

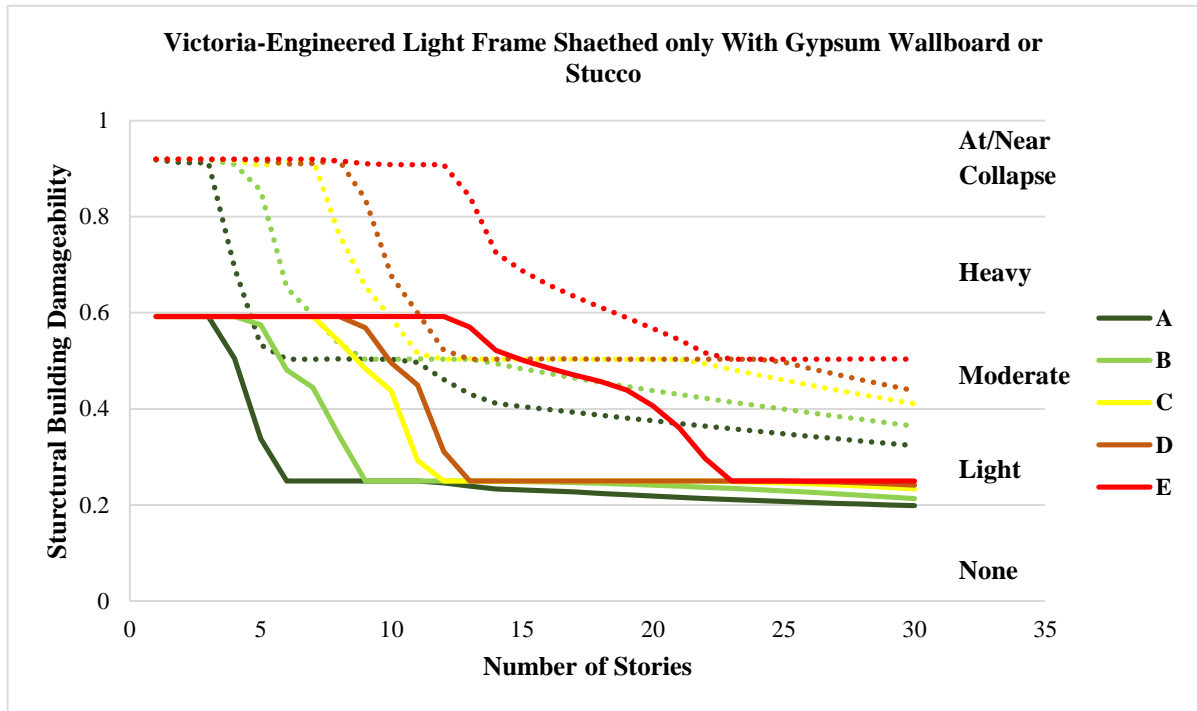

**Figure A-11: Upper and Lower Bound Limits of Building Damageability for Engineered Light Frame Structures sheathed with Gypsum Wallboard or Stucco resting on various soil conditions in Victoria, British Columbia**

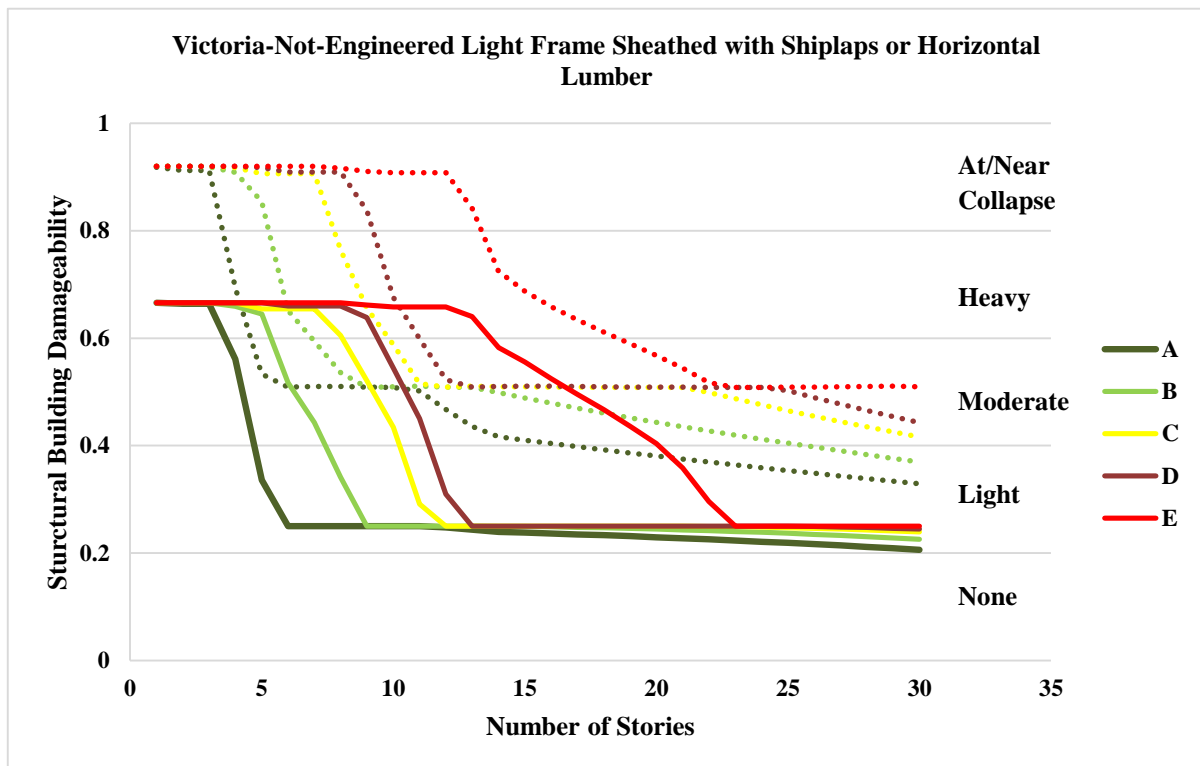

**Figure A-12: Upper and Lower Bound Limits of Building Damageability for Non-Engineered Light Frame Structures sheathed with Horizontal Lumber or Shiplaps resting on various soil conditions in Victoria, British Columbia**