



uOttawa

L'Université canadienne  
Canada's university

FACULTÉ DES ÉTUDES SUPÉRIEURES  
ET POSTDOCTORALES



uOttawa

L'Université canadienne  
Canada's university

FACULTY OF GRADUATE AND  
POSTDOCTORAL STUDIES

Mohammad Anwar Hossain

AUTEUR DE LA THÈSE / AUTHOR OF THESIS

Master of Computer Science

GRADE / DEGRÉ

School of Information Technology and Engineering

FACULTÉ, ÉCOLE, DÉPARTEMENT / FACULTY, SCHOOL, DEPARTMENT

LORNAV: A Web-based Tool for Personalized 3D Navigation of Distributed Learning Object  
Repositories

TITRE DE LA THÈSE / TITLE OF THESIS

Abdulmotaleb El Saddik

DIRECTEUR (DIRECTRICE) DE LA THÈSE / THESIS SUPERVISOR

CO-DIRECTEUR (CO-DIRECTRICE) DE LA THÈSE / THESIS CO-SUPERVISOR

EXAMINATEURS (EXAMINATRICES) DE LA THÈSE / THESIS EXAMINERS

Michael Weiss

Jiying Zhao

Gary W. Slater

LE DOYEN DE LA FACULTÉ DES ÉTUDES SUPÉRIEURES ET POSTDOCTORALES /  
DEAN OF THE FACULTY OF GRADUATE AND POSTDOCTORAL STUDIES

**LORNAV: A WEB-BASED TOOL FOR PERSONALIZED  
3D NAVIGATION OF DISTRIBUTED LEARNING  
OBJECT REPOSITORIES**

BY

MOHAMMAD ANWAR HOSSAIN

A THESIS SUBMITTED TO THE  
FACULTY OF GRADUATE AND POSTDOCTORAL STUDIES IN  
PARTIAL FULFILLMENT OF THE REQUIREMENTS FOR THE  
DEGREE OF MASTER OF COMPUTER SCIENCE

OTTAWA-CARLETON INSTITUTE FOR COMPUTER SCIENCE  
SCHOOL OF INFORMATION TECHNOLOGY AND ENGINEERING  
UNIVERSITY OF OTTAWA

© MOHAMMAD ANWAR HOSSAIN, 2005



Library and  
Archives Canada

Bibliothèque et  
Archives Canada

Published Heritage  
Branch

Direction du  
Patrimoine de l'édition

395 Wellington Street  
Ottawa ON K1A 0N4  
Canada

395, rue Wellington  
Ottawa ON K1A 0N4  
Canada

*Your file* *Votre référence*  
*ISBN: 0-494-11294-8*  
*Our file* *Notre référence*  
*ISBN: 0-494-11294-8*

**NOTICE:**

The author has granted a non-exclusive license allowing Library and Archives Canada to reproduce, publish, archive, preserve, conserve, communicate to the public by telecommunication or on the Internet, loan, distribute and sell theses worldwide, for commercial or non-commercial purposes, in microform, paper, electronic and/or any other formats.

The author retains copyright ownership and moral rights in this thesis. Neither the thesis nor substantial extracts from it may be printed or otherwise reproduced without the author's permission.

**AVIS:**

L'auteur a accordé une licence non exclusive permettant à la Bibliothèque et Archives Canada de reproduire, publier, archiver, sauvegarder, conserver, transmettre au public par télécommunication ou par l'Internet, prêter, distribuer et vendre des thèses partout dans le monde, à des fins commerciales ou autres, sur support microforme, papier, électronique et/ou autres formats.

L'auteur conserve la propriété du droit d'auteur et des droits moraux qui protègent cette thèse. Ni la thèse ni des extraits substantiels de celle-ci ne doivent être imprimés ou autrement reproduits sans son autorisation.

---

In compliance with the Canadian Privacy Act some supporting forms may have been removed from this thesis.

Conformément à la loi canadienne sur la protection de la vie privée, quelques formulaires secondaires ont été enlevés de cette thèse.

While these forms may be included in the document page count, their removal does not represent any loss of content from the thesis.

Bien que ces formulaires aient inclus dans la pagination, il n'y aura aucun contenu manquant.

  
**Canada**

# Abstract

This thesis presents LORNAV, a prototype web-based 3D tool designed to visualize Learning Objects (LOs) in a virtual environment over the Internet. The learning objects focused on are represented using the IEEE Learning Object Metadata (LOM) standard and are distributed among multiple repositories. The repositories may be located locally on the LORNAV server or be distributed elsewhere on the Internet. LORNAV dynamically creates a 3D representation of each of the LOs from the LOM elements based on a predefined template and displays it in 3D virtual environment using several visualization metaphors. The creation of the 3D virtual environment is also influenced by the individual user profile that reflects the interest of the user using the system. LORNAV allows the user to navigate through the 3D environment, view the associated metadata of the 3D objects, read/play the content, and select the objects of interest to create a personal space within the 3D environment. The introduction of personal space provides the user with a familiar navigation space consisting of LOs of his/her choice.

## Acknowledgements

First and foremost, I would like to convey my sincere gratitude and indebtedness to my supervisor, Dr. Abdulmotaleb El Saddik, for giving me the opportunity to pursue research on this rapidly emerging field and move forward along the path of innovation and novelty. I thank him for the many discussions, sometimes demanding and frustrating, but eventually problem-solving. His invaluable research ideas and experience kept me motivated all the way towards the progress and completion of this research work.

I am thankful to my co-supervisor, Prof. Pierre Lévy, for the support he provided during this work. His enthusiasm and eagerness have always been a driving force for me.

I would like to thank my lovely wife Shaila, for her inspiration, understanding and support throughout my graduate studies. I thank my parents for their constant motivation. I am also grateful to all my friends and fellow MCRLab students for their support, suggestions and constructive discussions. My special thanks go to Shamim, Mehedi, Anis, Abdur Rahman, Bogdan, and Souhail Abdala.

I thankfully acknowledge the financial assistance of the Social Sciences and Humanities Research Council of Canada (SSHRC) and of the Natural Sciences and Engineering Research Council Canada (NSERC) through its Learning Objects Repositories Network (LORNET).

# Table of Contents

<b>ABSTRACT.....</b>	<b>II</b>
<b>ACKNOWLEDGEMENTS .....</b>	<b>III</b>
<b>TABLE OF CONTENTS .....</b>	<b>IV</b>
<b>LIST OF TABLES .....</b>	<b>VII</b>
<b>LIST OF FIGURES .....</b>	<b>VIII</b>
<b>LIST OF ABBREVIATIONS .....</b>	<b>X</b>
<b>CHAPTER 1 INTRODUCTION.....</b>	<b>1</b>
1.1 BACKGROUND AND MOTIVATION .....	1
1.2 EXISTING PROBLEMS.....	2
1.3 OBJECTIVE AND CONTRIBUTION .....	3
1.4 PUBLICATIONS RESULTING FROM THIS RESEARCH.....	4
1.5 THESIS ORGANIZATION .....	5
<b>CHAPTER 2 LITERATURE BACKGROUND AND RELATED WORK.....</b>	<b>7</b>
2.1 LITERATURE BACKGROUND .....	7
2.1.1 <i>Definition of Learning Objects</i> .....	7
2.1.2 <i>Learning Object Metadata</i> .....	8
2.1.3 <i>Learning Object Repositories</i> .....	10
2.1.4 <i>3D Visualization and Virtual Reality</i> .....	10
2.1.5 <i>Virtual Reality Modeling Language</i> .....	12
2.1.6 <i>The Need for 3D Visualization</i> .....	12
2.1.7 <i>Design Guidelines for 3D Environment</i> .....	13
2.2 RELATED WORK .....	14
2.2.1 <i>VR-VIBE</i> .....	15
2.2.2 <i>Virgilio</i> .....	16

2.2.3 <i>CiVeDi</i> .....	18
2.2.4 <i>Periscope</i> .....	20
2.2.5 <i>AWE3D</i> .....	21
2.2.6 <i>WebBook and Web Forager</i> .....	22
2.3 SUMMARY .....	24
<b>CHAPTER 3 SYSTEM DESIGN .....</b>	<b>26</b>
3.1 LORNAV OVERALL ARCHITECTURE .....	26
3.1.1 <i>Overview</i> .....	26
3.1.2 <i>Use Case Model</i> .....	27
3.1.3 <i>Architecture</i> .....	29
3.1.4 <i>Features</i> .....	31
3.2 THREE DIMENSIONAL VISUALIZATION AND NAVIGATION.....	33
3.2.1 <i>Visual Metaphors</i> .....	33
3.2.2 <i>Templates of 3D Objects</i> .....	35
3.2.3 <i>Mapping LOM Elements to Visualization</i> .....	38
3.2.4 <i>Data Clustering</i> .....	39
3.2.5 <i>Design of Dynamic 3D View Generation Module</i> .....	40
3.2.6 <i>Navigation Model</i> .....	42
3.2.7 <i>Interaction Model</i> .....	44
3.3 PERSONALIZATION OF 3D ENVIRONMENT .....	46
3.3.1 <i>Personalization Requirements</i> .....	46
3.3.2 <i>Personalization Profile</i> .....	47
3.3.3 <i>Design of Personalization Module</i> .....	47
3.4 DATA ACCESS .....	50
3.4.1 <i>Data Source and Access Interface</i> .....	50
3.4.2 <i>Data Access Strategy</i> .....	51
3.4.3 <i>Design of Data Access Module</i> .....	51
3.5 SUMMARY .....	54
<b>CHAPTER 4 IMPLEMENTATION.....</b>	<b>55</b>

4.1 TECHNOLOGY REQUIREMENTS .....	55
4.2 DEVELOPMENT OF SOFTWARE ARCHITECTURE .....	56
4.3 EXAMPLE INTERFACES .....	58
4.3.1 <i>Navigational Interfaces</i> .....	59
4.3.2 <i>Interaction Interfaces</i> .....	61
4.4 SUMMARY .....	63
<b>CHAPTER 5 EVALUATION.....</b>	<b>64</b>
5.1 USER STUDIES.....	64
5.1.1 <i>Procedures</i> .....	67
5.1.2 <i>Results</i> .....	69
5.2 USABILITY INSPECTIONS .....	73
5.2.1 <i>Procedure</i> .....	74
5.2.2 <i>Results</i> .....	74
5.3 SUMMARY .....	76
<b>CHAPTER 6 SAMPLE APPLICATION .....</b>	<b>77</b>
6.1 LORNAV IN E-LEARNING APPLICATION.....	77
6.2 EXTENSION OF LORNAV .....	80
<b>CHAPTER 7 CONCLUSION AND FUTURE WORK.....</b>	<b>81</b>
7.1 CONCLUSION.....	81
7.2 FUTURE WORK.....	82
<b>BIBLIOGRAPHY .....</b>	<b>84</b>

# List of Tables

Table 2.1 Base schema categories of LOM .....	9
Table 2.2 Summary of features in related tools .....	25
Table 3.1 Selected LOM elements for visualization.....	38
Table 5.1 VE multi-criteria evaluation results by the test participants.....	71
Table 5.2 Heuristic evaluation results by the test participants.....	75
Table 6.1 DC-LOM-ARIADNE semantic mapping [29] .....	80

# List of Figures

Figure 2.1 Summary information of a selected document in VR-VIBE.....	16
Figure 2.2 High-level architecture of Virgilio .....	17
Figure 2.3 CiVeDi tour generation process .....	19
Figure 2.4 PERISCOPE visualization engine.....	20
Figure 2.5 The architecture of AWE3D.....	22
Figure 2.6 Collection of web pages in a WebBook .....	23
Figure 2.7 The Web Forager.....	24
Figure 3.1 The LORNAV use case model.....	28
Figure 3.2 High-level architecture of LORNAV .....	30
Figure 3.3 3D-Room information space metaphor .....	33
Figure 3.4 Cone trees .....	33
Figure 3.5 Sample new box metaphor .....	35
Figure 3.6 Sample familiar metaphor .....	35
Figure 3.7 Prototype definition and 3D representation of LOM .....	36
Figure 3.8 Prototype definition and 3D representation of LOM attributes.....	37
Figure 3.9 Dynamic 3D view generation algorithm .....	40
Figure 3.10 Sample LOM-XML stream .....	41
Figure 3.11 Use case of LORNAV navigational model .....	43
Figure 3.12 Use case of LORNAV interaction model.....	45
Figure 3.13 An XML excerpt of user profile.....	47
Figure 3.14 Profile-based personalization algorithm.....	48
Figure 3.15 Selection-based personalization algorithm.....	49
Figure 3.17 Data aggregation.....	53
Figure 4.1 Model-View-controller Architecture in LORNAV .....	57
Figure 4.2 Sample 3D environment in a new box-type metaphor .....	60
Figure 4.3 Sample 3D environment in a familiar metaphor .....	60
Figure 4.4 Sample search interface.....	61

Figure 4.5 Sample interface for touching and clicking a LO of type image.....	62
Figure 4.6 Sample interface for touching and clicking a LO of type html .....	63
Figure 5.1 Usability criteria of VE assessed by MAUVE [34].....	65
Figure 5.2 Sample questions on VE navigation in MAUVE [34] .....	69
Figure 5.3 Evaluation of overall VE characteristics by a particular subject.....	70
Figure 5.4 Results of the heuristic evaluation by a particular subject .....	75
Figure 6.1 Shared metadata space between SCORM and LOM.....	78
Figure 6.2 LORNAV in UbiLearn environment.....	79
Figure 6.3 Playing a movie in LORNAV/ UbiLearn integrated environment.....	79

# List of Abbreviations

LO: Learning Object  
LOM: Learning Object Metadata  
LOR: Learning Object Repository  
LORNAV: Learning Object Repository NAVigator  
VRML: Virtual Reality Modeling Language  
EAI: External Authoring Interface  
ECL: eduSource Communication Layer  
LORNET: Learning Object Repositories Network  
VR: Virtual Reality  
VE: Virtual Environment  
AR: Augmented Reality  
2D: Two dimensional  
3D: Three dimensional  
XML: eXtensible Markup Language  
SCORM: Sharable Content Object Reference Model  
JDBC: Java Database Connectivity  
UI: User Interface  
DB: Database  
MVC: Model-View-Controller  
AICC: Aviation Industry CBT Committee  
IMS: Information Management System  
LMS: Learning Management System  
EIS: Enterprise Information System  
HCI: Human Computer Interaction

# Chapter 1

## Introduction

### **1.1 Background and Motivation**

Three-dimensional (3D) information visualization has quickly been gaining popularity in recent years. The widespread use of the Internet and the advancement of computer technology have made this journey even more viable. Learning, as a result, has been a common practice on the distributed network-based environment. More and more learning materials are constantly being added to repositories by the distributed learning communities. These huge sources of learning information, when organized according to standards instead of random ways, would create a huge learning base on the Web.

Considerable efforts in the past few years have aimed to standardize metadata elements as a common method for identifying, searching, and retrieving Learning Objects (LOs) [7]. The IEEE Learning Object Metadata (LOM) [61] is one such effort towards more accessible, more reusable, and more interoperable LOs. The LOs are being stored over multiple distributed Learning Object Repositories (LORs). The metadata that describes those LOs are stored either with the LOs or in separate repositories.

With the steady increase of LOs and LOM-based repositories, the challenge has now shifted to novel access paradigms [6] in order to facilitate learners' or teachers' effectiveness in navigating, exploring, and searching LOs of their interest. The traditional form-based way of searching information might be helpful in this respect. However, other innovative approaches to information visualization such as 3D visual interface models may be explored. 3D visual interfaces would not substitute the traditional ways, rather, they would help to augment the learner's experience in the intuitive visual environment.

Information visualization in general has become vigorous and thriving in the last ten years [3, 8]. Lots of visualization research has come into focus varying from scientific data visualization [28] to more abstract data visualization. Unlike with scientific data where data are often ordered, there is no obvious way to visualize abstract data such as LOM.

This research aims at representing LOs in 3D environment by leveraging prior research on 3D information visualization and digital libraries. The use of several visualization metaphors is investigated to present the 3D representation of LOs in virtual environment. The issue of information overflow in 3D environment is also addressed. Finally, a web-based prototype tool including these functionalities is created.

## **1.2 Existing Problems**

While unprecedented advances have been made in the field of data visualization, the lack of extendibility of existing systems made them almost impossible to reuse. Most systems, particularly the 3D visualization systems, visualize data in the form of 3D objects in some fixed metaphors. Also the data used are based on some local repositories that do not follow any standard structures. These made the use of those systems restricted to the domains they were originally intended.

Moreover, almost no system considers the use of distributed data that are huge in numbers and have generic interface to those data. This hugeness of data brings substantial challenges on how to display them effectively in the 3D environment. The adoption of personalization is an effective way to filter the data of interest. In addition to personalization technique, further measures are needed to visualize objects in 3D. The use of existing features, such as level-of-details, in the modeling languages prove to be efficient in rendering objects gradually in the 3D environment.

Overall, there is no specific system that attempts to visualize distributed LOs as a form of educational data. We focused on this direction and leveraged several existing techniques in order to deliver the distributed LOs in the client's desktop in the 3D environment.

### **1.3 Objective and Contribution**

The increased demand of distributed and tele-collaborative learning pushes the organization and delivery of LOs to be more intuitive and interactive to the learning community. Learners and teachers are not satisfied with the traditional way of exploring LOs [54]. The objective of this research is to enhance the typical navigational experience of the learner in order to explore LOs from distributed LORs. An attempt has been made to provide new environment (for example, 3D virtual environment) that will display the LOs and enable users to perform search and retrieval of the objects. A Web-based VR tool has been developed to provide a personalized navigation space in the virtual environment (VE) consisting of LOs of interest. The tool further lays the framework to author the Learning Objects by combining two or more objects together [23]. The authoring process itself is beyond the scope of this thesis.

The research in this thesis has been performed by leveraging several existing techniques on information visualization and data access mechanism. However, most of the

formulation, implementation, and experimentation found in this thesis are original work. The contribution of this thesis as a whole can be summarized in the following:

- First attempt to visualize LOs distributed over multiple repositories where the LOs are described by IEEE LOM standard and retrieved via web service based interface.
- Creation of multiple visual metaphors to navigate Learning Object Repositories in 3D virtual environment.
- Providing personalization in the 3D environment that facilitates user's navigation of the LOs of their interest.
- Implementation of the LORNAV's visualization techniques in an e-learning application using different metadata standards. The metadata standards that LORNAV supports other than LOM are SCORM [68] and Dublin Core [67].

#### **1.4 Publications Resulting From This Research**

The following four papers have been published. The first two are directly related with the thesis topic while the rest are efforts towards suggesting future work.

1. **M. Anwar Hossain**, Md. Abdur Rahman, and Abdulmotaleb El Saddik, "Architecture for 3D Navigation and Authoring of Distributed Learning Object Repositories". In Proceedings of the International Workshop on Haptic Audio Visual Environments and their Applications (HAVE 2004), Ottawa, Canada, October 2-3, 2004.
2. Md. Abdur Rahman, **M. Anwar Hossain**, and Abdulmotaleb El Saddik, "LORNAV: A Demo of a Virtual Reality Tool for Navigation and Authoring of Learning Object Repositories". In Proceedings of the 8-th IEEE International Symposium on Distributed Simulation and Real Time Applications (DS-RT 2004), Budapest, Hungary, October 21-23, 2004.

3. **M. Anwar Hossain**, Abdulmotaleb El Saddik, "Creating Knowledge and Semantic Web Applications on the Web", In Proceedings of the 2nd International Symposium on Innovation in Information & Communication Technology (ISIICT 2004), Amman, Jordan, April 21-22, 2004.
4. **M. Anwar Hossain**, Abdulmotaleb El Saddik and Pierre Lévy, "Towards a Multi-domain Semantic Web Application". In Proceedings of the Canadian Conference on Electrical and Computer Engineering (CCECE 2004), Niagara, Ontario, Canada, May 2-5, 2004.

## **1.5 Thesis Organization**

The remainder of the thesis is organized as follows:

**Chapter 2** presents an overview of background literature and related studies. Background concepts on learning object, learning object metadata, 3D visualization, virtual reality, and so on are provided first. Next, several 3D information and document visualization systems are described generally, with an emphasis on learning object repository visualization.

**Chapter 3** proposes our idea and elaborates on the system design phase. The design phase includes the dynamic 3D visualization technique, the personalization technique and the distributed data access technique.

**Chapter 4** focuses on the implementation of the system. This includes our choice of technology, software architecture, and sample user interfaces of the system.

**Chapter 5** covers the evaluation result of our system, focusing on evaluations of system usability and user studies.

**Chapter 6** describes one sample application where the LORNAV tool has been integrated. Here, several issues concerning the adaptation of LORNAV into separate application domains is stated.

Finally, the work is summarized in **Chapter 7**, which also includes a conclusion and a discussion of potential future work.

## Chapter 2

# Literature Background and Related Work

### 2.1 Literature Background

The work in this thesis is an attempt to visualize distributed LOs in a 3D environment, so at first the notion of Learning Object (LO), the metadata standard that describes LO, and the repositories that are used to store LOs and/or associated metadata are introduced. This is followed by an overview of 3D visualization and Virtual environment, the 3D modeling language, and the plug-in requirements to view the 3D models on the web.

#### 2.1.1 Definition of Learning Objects

A Learning Object, according to IEEE Learning Object Metadata (LOM) standard, is "any entity, digital or non-digital, that may be used for learning, education or training" [61]. This is a very broad definition which encompasses everything related to learning as a Learning Object. Hence a learning object could be a picture of the Mona Lisa, a

document on the Mona Lisa (that includes the picture), a course module on da Vinci, a complete course on art history, or even a 4 year master curriculum on western culture [6].

A Learning Object can also be defined as an educational object used to enhance learning. It could include text, images, web sites, videos, animation, audio, photographs, or presentations. For example, a module or object within an online course might consist of all of the objects listed above and yet be a learning object [72].

Other definitions have attempted to narrow down the above definition. In [55], a learning object is considered as a reusable digital resource to support learning. This also emphasizes those resources that can be accessed via network irrespective of its granularity. By excluding non-digital objects and classifying every digital resource as LO, this definition, according to [7], undermines the primary concept of context and modularity.

Similarly, there have been many discussions on the granularity (e.g. size<1KB, size<=1MB) and type (e.g. digital, non-digital) of the learning object. However, all the definitions and discussions aim at establishing a general framework of learning, where learners can share and reuse their learning resources and experiences.

### **2.1.2 Learning Object Metadata**

Learning Object Metadata (LOM) [61] is a standard defined by the IEEE Learning Technology Standard Committee towards a common method for identifying, searching and retrieving Learning Objects. LOM is defined as a hierarchical structure consisting of nine broad categories as stated in Table 2.1. Under each of the categories, there are several metadata elements. However, all these data elements are optional as defined by the standard.

Table 2.1 Base schema categories of LOM

No.	Category	Explanations
1.	General	General metadata, such as the identifier, title, language, keyword, structure, or description of a LO.
2.	Life Cycle	History and current state information, such as status, version, and role of a LO.
3.	Meta-MetaData	Metadata that describe the metadata of the LO itself.
4.	Technical	Covers all technical information about a LO, such as format, size, location, duration, browser requirements, etc.
5.	Educational	Describes educational and pedagogic characteristics of the LO, such as interactivity, difficulty, end-user type, etc.
6.	Rights	Intellectual property rights for commercial use and ownership of a LO.
7.	Relation	Relationship in between and other LOs.
8.	Annotation	Provides additional information about a LO including assessments and suggestions by other learners.
9.	Classification	Classifies a LO with respect to a classification system.

LOM structure is extensible which allows new data elements to be added to its hierarchy. It can be adapted to the needs of a specific community through the use of Application Profile [6], yet preserving its original compatibility. Application Profile can be defined by giving elements a mandatory condition, by restricting values for certain data elements, by imposing relationship between elements, by excluding some data elements, and by identifying taxonomies and classifications. E.g. CanCore [69] is an application profile of the IEEE metadata [61] scheme.

Without the use of Application Profile, a LOM record probably would not contain any meaningful data (because of the optional characteristics of the LOM elements) thereby causing frustration to the user. However, the effort towards standardization of LOM remains unprecedented. It is the responsibility of the community that maintains the LOM repository to fill meaningful data in the LOM elements to be more usable and sharable by others.

### **2.1.3 Learning Object Repositories**

Learning Object repositories (LORs) typically contain learning objects or references to them along with the metadata that defines the learning objects (LOs) [9]. The process of storing LOs and their metadata may follow different approaches. They could either be stored physically together or separated yet providing a common interface. Hence, the terms LORs and LOM Repository are sometimes used interchangeably.

A LOR allows searching and retrieving of LOs by either restricted or unrestricted users. The search could vary from a simple keyword-based search to an advanced element-level search. Again these kinds of searches may be applied against one single repository or multiple heterogeneous repositories. In the case of multiple repositories, the use of federated search may prove beneficial [6]. The federated search mechanism hides the underlying locations of the repositories and provides the user an interface of a single virtual repository.

There are several communities who maintain LORs to share and distribute knowledge. Examples of some LORs include ARIADNE [70, 21], eduSource [72], EdNA LOR [73], and LORNET [71].

### **2.1.4 3D Visualization and Virtual Reality**

3D visualization is a way to represent real or abstract objects and information to be displayed in a computer generated 3D environment that can be generated using several modeling languages such as VRML [58] and X3D [63]. Objects within a 3D world are designed with the perspective and shadows somewhat similar to the real world, which change when the user moves around. This concept of 3D leads to Virtual Reality when extra senses for example, touch and/or motion are involved.

Virtual Reality (VR) or Virtual Environment (VE), as defined in [44], is an artificially created world that gives the user a sense of presence in that world, moving around and manipulating the objects he/she is viewing. In a VR world, a user is able to walk, run, or even fly to explore the environment from different viewpoints that are not possible in the real world [45]. The ability to touch, animate, move, and reposition of objects is a true benefit for the VR user. This illusion of reality can be experienced by using different VR hardware like head-mounted display (HMD), data gloves, Binocular Omni-Orientation Monitor (BOOM), and other input and sensual devices.

An example of a VR world could be a virtual library where the users can navigate around, browse, choose books and read the contents. Although the virtual library is designed by a computer program, the virtual books inside the library could represent real books. This eventually conveys the fact that the virtual world could be designed from data taken from multiple physical repositories.

From the above definitions and example it is obvious that user interaction tasks in a 3D environment are very important. These tasks can be divided into three main categories, including navigation, selection/manipulation, and system control [42]:

- Navigation is a very fundamental operation users perform in large 3D environment. Several issues can influence 3D navigation, such as support for spatial awareness, efficient and comfortable movement, and lightweight navigation. In general, the navigation tasks refer to exploration, search and maneuvering. The exploration tasks are simple navigation without any defined purpose or direction. Unlike exploration, search is a more specific navigation task which a user performs to go to a particular location or view a particular item. The maneuvering tasks are performed by changing the viewpoint so as to get new insight or understanding of the environment.
- Selection/manipulation helps the user to select objects, position them at different locations, and rotate them at a different angle.

- Finally the system control tasks are performed to change either the state of the system or the mode of interaction. These tasks are implemented using graphical menus, voice commands, gesture interaction or by any other combination of the different means.

### **2.1.5 Virtual Reality Modeling Language**

Virtual Reality Modeling Language (VRML) [58] is a text-based language that enables us to create three-dimensional worlds consisting of 3D shapes, animations, image texture, light sources, sound effects and other multimedia objects [19].

The VRML world can be displayed either from the local machine or from the Web. The delivery of the VRML files across the Web uses the "model/world" MIME type. The actual display of the VRML world requires a VRML browser that is configured as a plug-in for different web browsers. There are several VRML browsers such as Cortona VRML Client [64], BS Contact VRML/X3D [65], and blaxxun Contact 5 [66]. Using a VRML browser, users can navigate a 3D world, interact with the content, trigger an animation and play a movie or sound from within the virtual environment. The support of hyperlinks from the 3D scene makes VRML even more powerful to be used with other server side technologies, such as Java Servlets and Java Server Pages (JSPs).

VRML has been designed to be platform-independent and to work over low bandwidth connections. This has influenced many communities to use VRML for their virtual reality tool of choice.

### **2.1.6 The Need for 3D Visualization**

The explosive growth of information repository has raised new challenges on how we present and understand information. The limitations of current visualizations [3] are

pushing us to new visualization domain. A good number of researches have been performed to explore and find intuitive ways for information visualization in general and 3D visualization in particular. In summary, according to [1, 2, 76, 5, 43], the following are some of the benefits 3D visualization offer:

- Abstract data can be represented using 3D visual attributes for improved perception of data.
- Large quantities of data can be comprehended more easily in 3D, as opposed to 2D textual presentation, in the fixed computer landscape.
- Easier navigation and exploration of the information space than is possible in 2D scrolling-type navigation.
- Additional direct intuitive interactions can be provided with the entities of interest in 3D environment.
- Relationships and structure among displayed entities can be more easily found and understood.

The above benefits formulate the need for a 3D environment to visualize LO repositories in order to navigate and identify learning objects in a natural way different than just "filling in electronic forms" [6].

### **2.1.7 Design Guidelines for 3D Environment**

Information visualization in 3D environment does not always guarantee better and efficient presentation. User studies show that several issues can slow down performance in the real world and in 3D interfaces such as disorienting navigation, complex user actions, and annoying occlusions [47]. Hence, it is important to follow guidelines for the design of any 3D environment. Several researches may be attributed in this direction [20, 42] which, in summary, state:

- The number of navigation steps for users to perform a certain task should be minimal.
- Natural interaction should be used when replication of physical world is important.
- Interaction techniques should be based on application requirements, not one-size-fit-all solution.
- Text should be readable and well-rendered, have good contrast with no more than 30-degree tilt.
- Increased flexibility offered by several input devices should be adopted where necessary.
- Techniques such as occlusion, shadows, perspective and others should be used carefully.
- Unnecessary visual clutter, distractions, and reflections should be avoided.
- Simplified user movements should be provided by keeping planer movements where possible and by avoiding surprise movements such as going through walls.
- Items should be grouped in aligned structures in order to facilitate quick visual search.

The above summary remains as the base guidelines that have been followed in this research and development of 3D visualization of Learning Objects.

## **2.2 Related Work**

Few comparable works have been carried out in visualizing LOs in VE allowing dynamic interactions with the displayed objects. However, several systems do attempt to visualize database contents, web documents, hierarchical information, multidimensional datasets, and others. These works stand as a guideline for our work.

This section briefly discusses some of these systems and the basic concepts and architectures behind them.

### **2.2.1 VR-VIBE**

VR-VIBE [17] is one of the earlier prototypes of multi-user information retrieval and visualization systems which visualize search results on document collections and bibliographies in virtual environment. The search results are generated based on user-specified keywords. The keywords are placed on the 3D spatial locations also known as Point of Interest (POI). The documents relevant to each of the keywords are arranged closer to the corresponding POI. The documents relevant to all the keywords are placed in the center equally spaced from the POIs. Absolute relevance is depicted by the size and shade of the document's icon, the larger and brighter icons represent more relevant document.

The users of the VR-VIBE system can perform several interactions with the 3D search results. They can dynamically adjust the threshold level of relevancy in order to filter out less relevant documents. In addition to this, some other user interactions include navigating the virtual space, selecting individual documents by clicking on the document representation, dynamically dragging the queries to a new position to see the effect on the document space. Figure 2.1 shows a screen shot displaying the summary information about a document that a user has selected.

The visualization interface of VR-VIBE displays document collections from the file system, but not known to work with database records. It only provides one visualization environment. While visualizing massive document collections, the visualization method can easily obscure the document icons. Another disadvantage is that the large document icons, being more relevant, can hide the smaller icons of less relevant documents. VR-VIBE and our developed system LORNAV [22, 23] are not comparable to each other

because they work on two different domains of information having different architectures: the common aspect between them is the idea of 3D visualization.

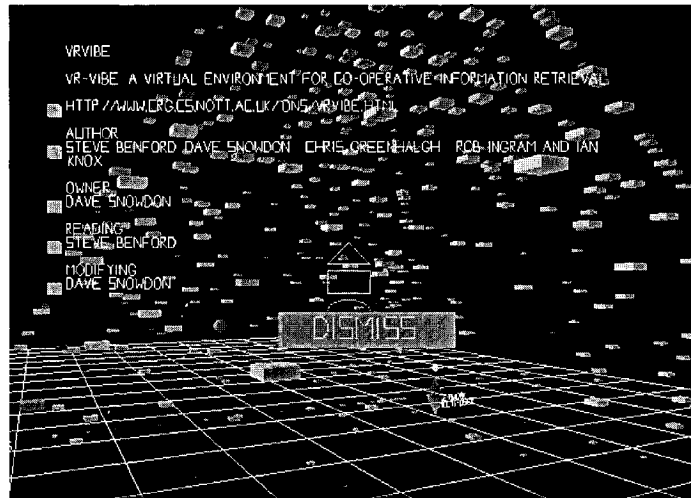

Figure 2.1 Summary information of a selected document in VR-VIBE

In LORNAV, data is retrieved from the distributed LOM repositories via web services call. It is built on a flexible architecture and can be extended to add new features as will be discussed in Chapter 3. However, VR-VIBE is obviously a motivating example towards the development of a 3D visualization system because of being one of the earlier systems.

### 2.2.2 Virgilio

Virgilio [40] is a non-immersive virtual reality system that attempts to visualize query results on a multimedia object database. The results are displayed in the VR environment in conjunction with metaphors based on some real world objects such as rooms, tables and portrait cases. The metaphors are defined by considering both the type of data they can support and the containment relationships among the different objects. The containment relationships are used as semantic relationships within the Virgilio framework.

Virgilio uses a dataset as input to create the visualization of the database objects. The dataset is generated by a query posed on a multimedia database. It then maps the query results to predefined 3D representations of real objects and produces final visualization as VRML [58] scenes. Virgilio tries to address the issue of not getting lost in a VR scene by enriching the scenes with reference points such as a flower vase, a painting in a room, etc. The issue of not getting lost in the VR scene is also addressed in [36, 14].

The Virgilio visualization framework is composed of several modules including a Metaphor Generator, a Scene Generator, and a Real World Object Repository. In addition to these modules, there is a generic query interface where the user can pose queries by specifying several criteria. Figure 2.2 shows the overall system architecture of Virgilio.

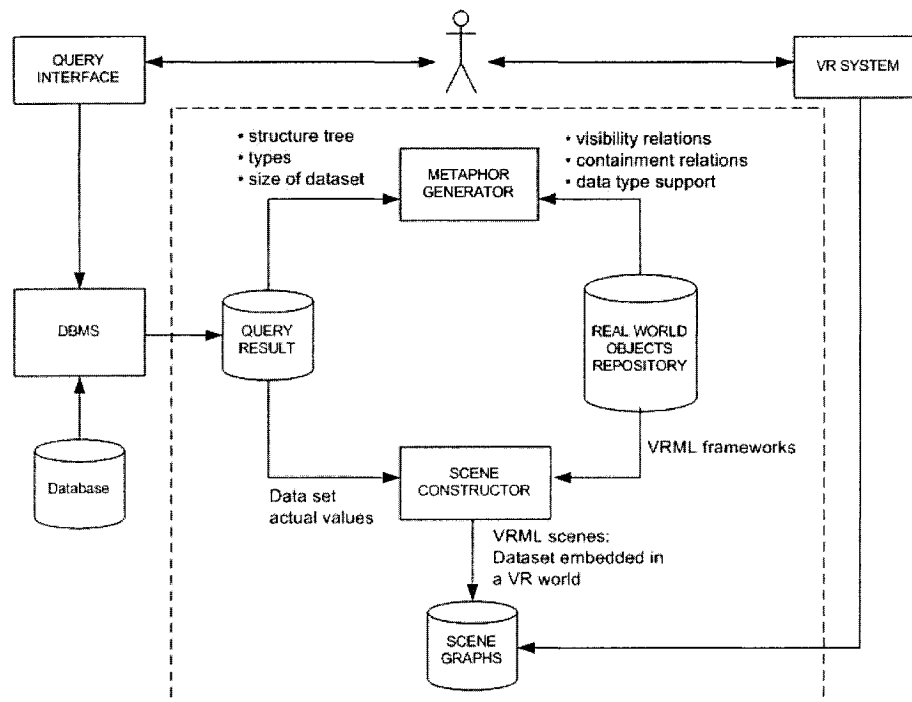

Figure 2.2 High-level architecture of Virgilio

Virgilio maps the entire dataset returned by the query to a building metaphor. This will have serious impact when the data volume is huge and the metaphor size is fixed. The

system cannot be used if the data are distributed over multiple networks or the Internet. The mapping of data objects with real world objects requires much consideration to set object size, shape, colour, and other attributes. This makes the mapping functionality very difficult to adopt.

### **2.2.3 CiVeDi**

The system presented in [16] aims to integrate multimedia database and virtual reality environment for customized visualization of cultural heritage information over a museum metaphor. Customization can be performed by the user on many aspects. The user is able to specify the appearance of the VE by choosing any museum architecture that is available in the system. The user can determine the type of the tour as linear or non-linear, customize the duration of his/her visit, and specify clustering criteria to define grouping of artifacts in the virtual scene. The idea of tour generation, although different in nature, is also adopted in [36], which creates guided tours to aid users while navigating in the virtual world. Another approach in [10], somehow similar to [36], proposes the idea of proactively adapting user interactions in 3D world to match their needs.

Other systems similar to CiVeDi, create dynamic virtual museum exhibitions with artifacts. One is ARCO [37], which attempts to take the benefit of virtual and augmented reality and provides a more realistic virtual environment to the user. ARCO also provides additional user interaction with the displayed 3D artifacts than is possible with CiVeDi.

CiVeDi [16] and its earlier version, ViRdB [15], adopted a modular architecture that consists of several functional units as shown in Figure 2.3. The main unit in this architecture is the Scene Repository that contains a Virtual Scene Unit (e.g 3D template

of a room), the Db-driven Objects (e.g. 3D abstract representations of images), and Autonomous Objects (e.g. plant, door).

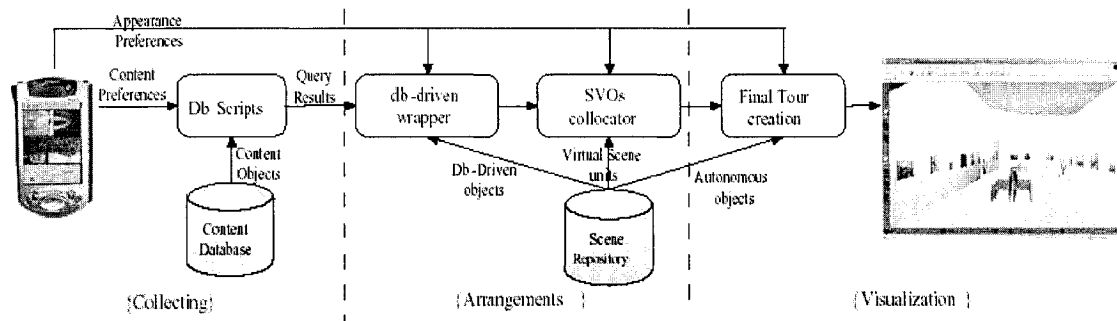

Figure 2.3 CiVeDi tour generation process

While CiVeDi offers many possibilities, it has some limitations. It needs to maintain a lot of physical dimensions to arrange specific kind of multimedia elements into the virtual scene unit. It is assumed that this will take a considerable amount of time and special requirements for the museum curator to customize the system for certain other multimedia contents, thereby reducing its expendability. The CiVeDi system does not follow any existing metadata standards such as IEEE LOM [61], Dublin Core [67], or MPEG-7 [74]. It rather uses some arbitrary metadata elements to define and search multimedia contents. This would make it harder to implement the system with databases using different schema and data elements. Furthermore, the CiVeDi system does not specify the actual user interaction with the displayed 3D objects. Contrary to these, the proposed architecture, LORNAV [22, 23], aims to visualize LOs in a VE that are defined using LOM metadata standard and are distributed over the Internet and accessed via web services call. It is also capable of integrating data from databases that follow a different standard by using simple mapping mechanism. We believe all these features make LORNAV a unique tool of its kind.

### 2.2.4 Periscope

The Periscope [11, 12] is another web-based system that visualizes web search results as 3D scenes. The search results are grouped as classes of documents based on several criteria including document language, server domains, number of matching keywords, document types, and so on. The user can further navigate the 3D space by selecting any specific document class which in turn displays the actual document links represented as 3D objects. The overall display is represented using any of the predefined visual metaphors. Figure 2.4 represents the several components of the Periscope visualization engine.

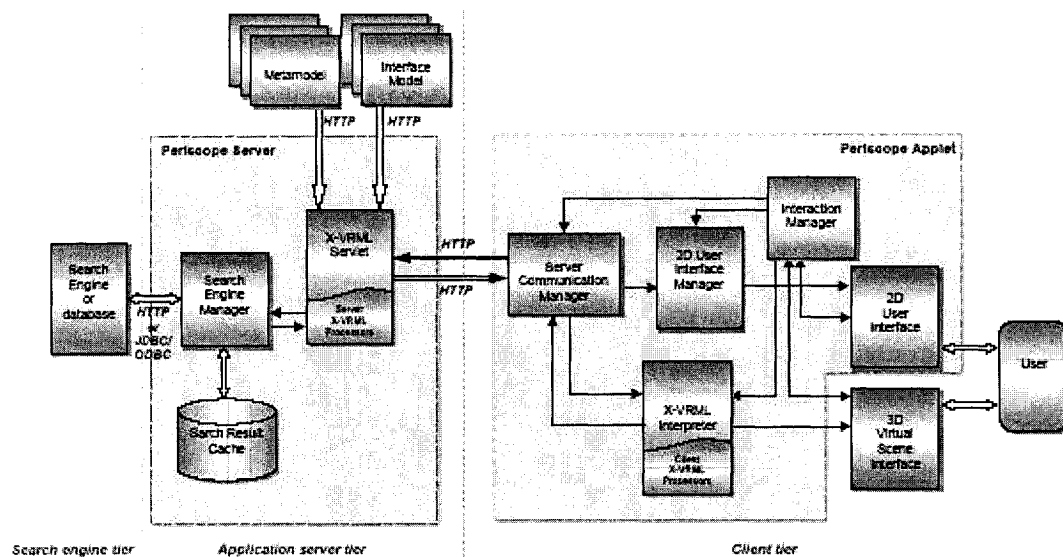

Figure 2.4 PERISCOPE visualization engine

One of the main drawbacks of the Periscope system is that there is no textual cue (for example title, author, etc.) attached with the 3D representation of the document, which forces the user to first select the object to view the real content. Moreover, the 3D objects are often laid on top of each other due to the high volume of search results. This makes selecting individual object very difficult and sometimes impossible. The system

does not keep track of the user's current viewpoint in the 3D scene. Hence, in case of any refresh actions performed by users the viewpoint is set to its initial position. This is very frustrating, especially if the search results are huge and the user has already navigated to some area of his/her interest.

Another notable fact with Periscope is that system performance is indeterminable when connecting it to a massive real life search engine database. In our approach, the above issues are carefully handled by attaching visual cues to each of the learning objects and storing the users' current viewpoint. Among other developments, users can perform several interactions such as view the metadata of the LO, view content, play multimedia objects in the 3D VE, select any particular object and store that object to his/her personal virtual space for review on subsequent visits.

### **2.2.5 AWE3D**

The approach taken in [32] addresses the issue of building adaptive 3D web sites in order to provide personalized environment to individual user. The adaptation process follows the guidelines presented in [41], which are grouped as Acquisition Task, Representation Task, and Production Task. Acquisition tasks are performed to build an initial model of the user by acquiring information about the user and his/her usage data. Representation tasks are performed to express the data gathered from the acquisition tasks to a formal system for further processing. Production tasks are performed to build the adaptive 3D environment for the user. AWE3D implements this adaptive model through a general architecture as shown in Figure 2.5.

In the AWE3D architecture, the usage data sensing module monitors the user's interaction with the 3D world and sends necessary events to the usage data recorder module via the Internet, which in turn stores those usage data in the user model database. The personalization choices from the personalization module are transferred

to the VRML world creator module to produce the 3D world to be viewed from the client browser. This idea of dynamic generation of personalized 3D worlds is also proposed in [13, 33].

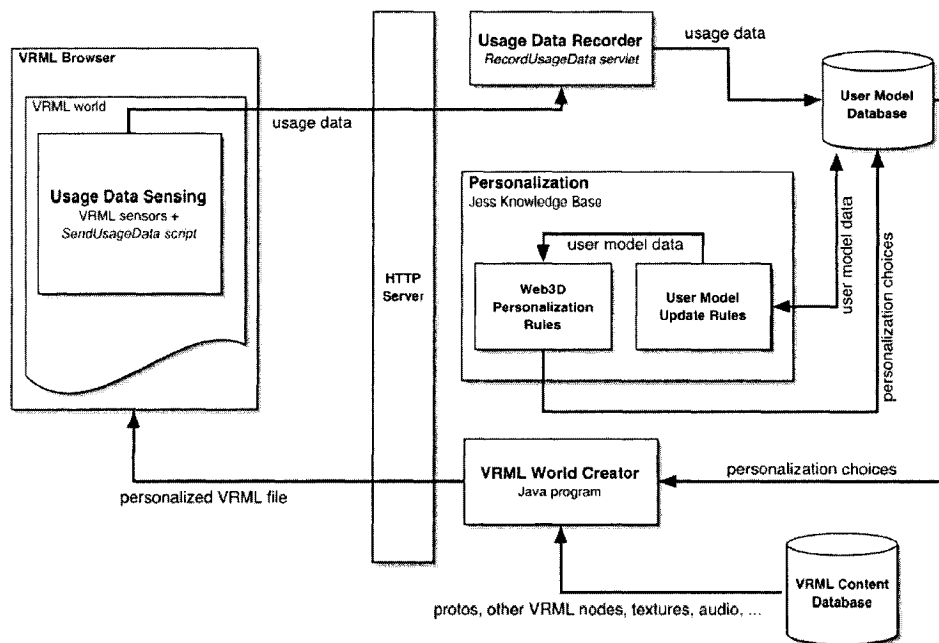

Figure 2.5 The architecture of AWE3D

The AWE3D [32] architecture is an attempt to show a standard way of creating a personalized 3D world. However, the system does not provide any specification of what kind of data it supports, what the data attribute names are, and how the system will react in case of large volume of data. Furthermore, it does not support distributed databases, which are very important in today's business. LORNAV [22] is more extendable and generic in this respect.

### 2.2.6 WebBook and Web Forager

WebBook [31] is an attempt to improve the access and presentation of information on the Web. It is a 3D representation of a book that allows rapid interaction with the

objects at a higher level than individual pages by keeping series of related HTML web pages together. It also enables users to see several pages at the same time, flip through the pages, and directly access a desired page. This is shown in Figure 2.6.

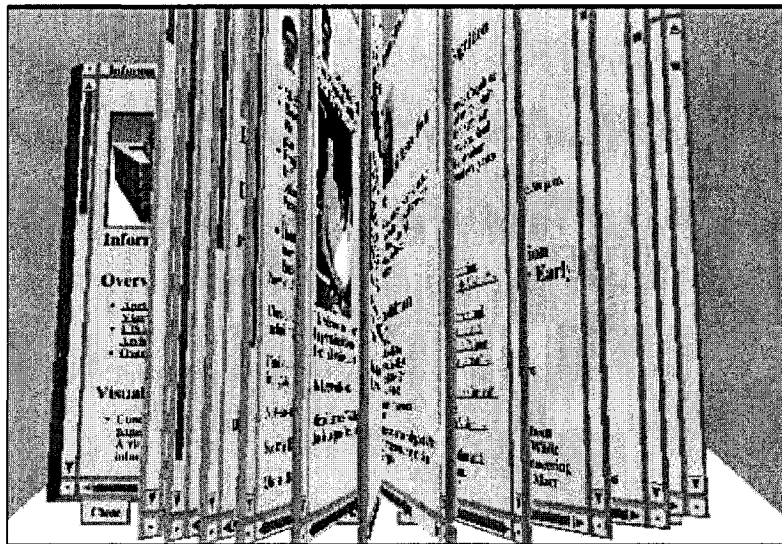

Figure 2.6 Collection of web pages in a WebBook

WebBook uses color links to show the interconnections between web pages. Red color links point to another page within the book, whereas blue color links point to a reference outside the book. In addition to this, WebBook provides several user friendly features including animated flip, page click, scan, bookmark, scrollbar, and scaling of font size.

The WebBook model may be used in several applications dealing with a specific collection of web pages. Sample applications could be Relative-URL Books, Home-Page Books, Topic Books, and Hot List Books.

Unlike WebBook, Web Forager [31] is an application that embeds WebBook and other objects in a hierarchical 3D workspace as shown in Figure 2.7. The design of the workspace is based on a familiar metaphor that includes books, desk, and bookshelf to

enable the user an easy and intuitive way of accessing web information. These applications, at the same time, demonstrate how we can take the benefit of computer and web technologies to assist our works.

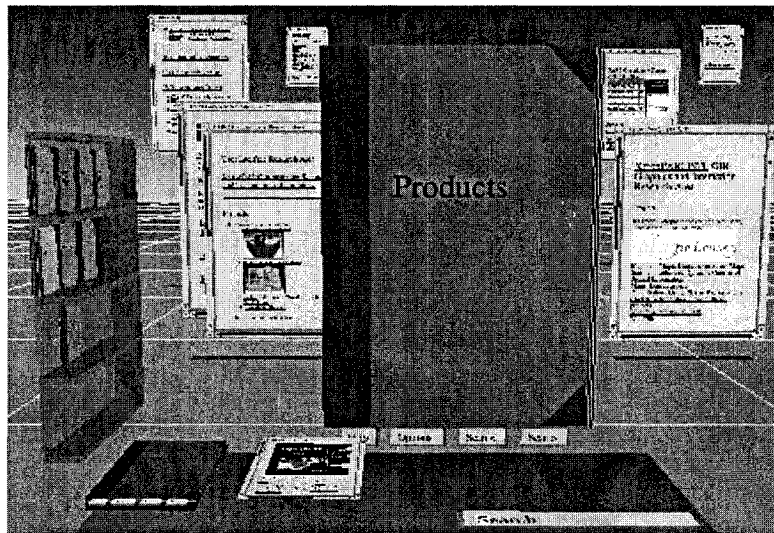

Figure 2.7 The Web Forager

WebBook and Web Forager each work as an early motivation to design 3D information space using familiar metaphor. The use of familiar metaphor is also suggested in [1, 31]. It is considered that this kind of metaphor works better for humans to pursue information more easily and quickly [1]. The idea of familiar metaphor is also adopted in LORNAV, though not in a completely similar fashion. Unlike WebBook and Web Forager, LORNAV has introduced several other metaphors to present the information (in this case, LOs) in the 3D environment to investigate the suitability of using different metaphors.

### **2.3 Summary**

This chapter offered an introductory overview of Learning Objects, Learning Object Metadata, Learning Object Repositories, Virtual Reality Modeling Language, 3D

visualization, and 3D visualization guidelines. The chapter then illustrated the design principles of several existing related tools including VR-VIBE, Virgilio, CiVeDi, Periscope, AWE3D, WebBook and Web Forager. The chapter also highlighted the similarities and differences among these tools and LORNAV. A comparative study of the features provided by these tools is summarized in Table 2.2.

Table 2.2 Summary of features in related tools

<b>Tool/ Architecture</b>	<b>3D Visualization elements</b>	<b>Metaphor</b>	<b>Search</b>	<b>Data source</b>
VR-VIBE	Search results on document collections and bibliographies	Open spatial	Keyword based	Local
Virgilio	Query results on a multimedia object database	Real world (e.g. room, table)	Generic	Not distributed
CiVeDi	Multimedia database of cultural heritage information	Museum	Explicit (not known), Implicit (User choices based)	Local, Distributed
Periscope	Web search results	Familiar, Holistic	Keyword based	Not known
AWE3D	Adaptive web sites	Building	Implicit (user profile based)	Local
WebBook and Web Forager	HTML web pages	Familiar (e.g. shelf, book)	Keyword based	Web

The tools summarized in Table 2.2 acts as a base of this research in terms of 3D visualization of information. However, these tools are good for specific domain and application which makes them unsuitable to scale and fit with the LOM [61] data model. This clearly reveals the lack of standard tool that can be reused to visualize learning objects in 3D VE. The development of LORNAV is an attempt towards this direction.

## Chapter 3

### System Design

This chapter describes the design and algorithm for the development of the prototype tool LORNAV. At first the overall system architecture is presented. Next, the overall system design is covered in three main phases including 3D visualization and navigation, personalization of 3D environment, and data access. These phases are then described in detail with UML notations.

#### **3.1 LORNAV Overall Architecture**

##### **3.1.1 Overview**

To visualize Learning Objects in 3D environment over the Web, LORNAV uses a 3D modeling language to design the 3D environment. As LOs are represented using the IEEE LOM [61] standard and are stored in distributed repositories, the 3D representation of each LOM record is visualized dynamically in the virtual environment, which eventually points to the actual LO by means of hyperlink.

The 3D representation of a LOM record is a template 3D object that is replicated dynamically for each LOM record. Instead of considering all the LOM elements to be included with the 3D representation of LOM, a subset of elements (for example title, language, format etc.) has been taken into consideration. This is due to the fact that all the LOM elements are optional. Also not all elements are important to be visualized (described in Section 3.2). Hence, selecting some important and necessary elements that are more likely to be filled by the learning community makes more sense.

There are thousands of LOM records in the repository that we use [72] and the number is increasing everyday. This forced us to implement a user preference model. Based on the user preference, a query posed on the distributed repository is likely to return a limited number of records pertaining to user interest. In case the user profile is not yet set up, the system retrieves only a couple of hundred records. This approach is taken to reduce the load on the visualization engine and to speed up rendering time.

In order to access LOM records from the distributed repositories, a data access mechanism is designed based on web service technology. The choice is influenced by the web service interface used at the individual repository level. The repository we use has a federated search interface that allows users to pose queries over all the repositories.

### **3.1.2 Use Case Model**

In this section we describe the high-level user-centric functional requirements of our system using UML-based use case diagram. The use case diagram in Figure 3.1 shows the interactions between external actors and LORNAV. The actors include System Administrator, Teacher, Learner, and Guest user. The use case model consists of several use cases which are described briefly in this section.

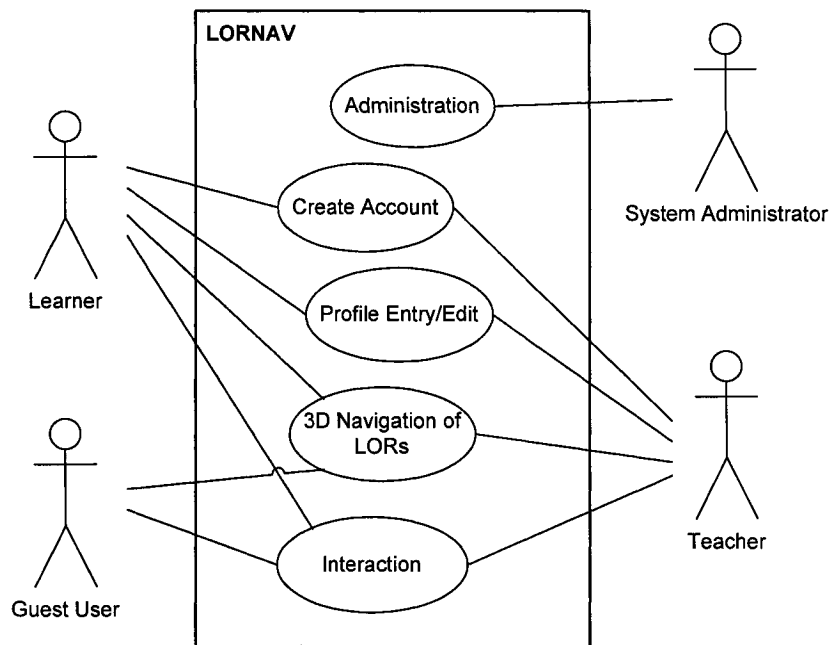

Figure 3.1 The LORNAV use case model

**Administration:** The Administration use case is included here to deal with different system administration tasks. Typical system administration tasks vary from assigning user roles, user profile and system preference maintenance, etc.

**Create Account:** This use case is used to refer to the creation of a user account. The security manager component of the system prompts the user to enter a username and password. Once the user is done, the system records the user account information, which can be used to log in to the system on subsequent visits.

**Profile Entry/Edit:** A learner or teacher can create or modify his/her profile. The security manager checks the user's credentials and for existing users it transfers control to the profile manager component, which prompts user to enter a new profile or to edit an existing profile.

**3D Navigation of LORs:** The learner or teacher, once logged in, can navigate the 3D world that is generated by the 3D scene generator engine. The 3D world includes LOM records represented using 3D objects and are based on individual user profile settings. Navigation facilitates the user to perform several other operations such as visual exploration, metaphor selection, search and maneuvering. These are described further in Section 3.3.6.

**Interaction:** The system allows users to interact with the 3D virtual environment. The interaction includes several other operations such as touching an object, clicking to view the content, clicking to hide the content, selecting an object, rotating the container, and changing background color. These are described further in Section 3.3.7.

### **3.1.3 Architecture**

The overall architecture of LORNAV consists of several functional modules as shown in Figure 3.2. In this figure, lines are used to show the connectivity between modules and intentionally omitted arrows for clarity. However, a more detailed architecture from an implementation point of view is given in Chapter 4.

The **System Controller** is the core component of the architecture. It intercepts all requests coming from the client, extracts request parameters, and maps to the appropriate model or view.

The **Session Manager** is responsible for managing a user's session that is used to track logged-in users for delivering personalized content.

The **Security Manager** module is responsible for all security related tasks, including managing user accounts, checking user's privilege, preventing hacking, and so on. The user account information is stored in the **User Account DB**.

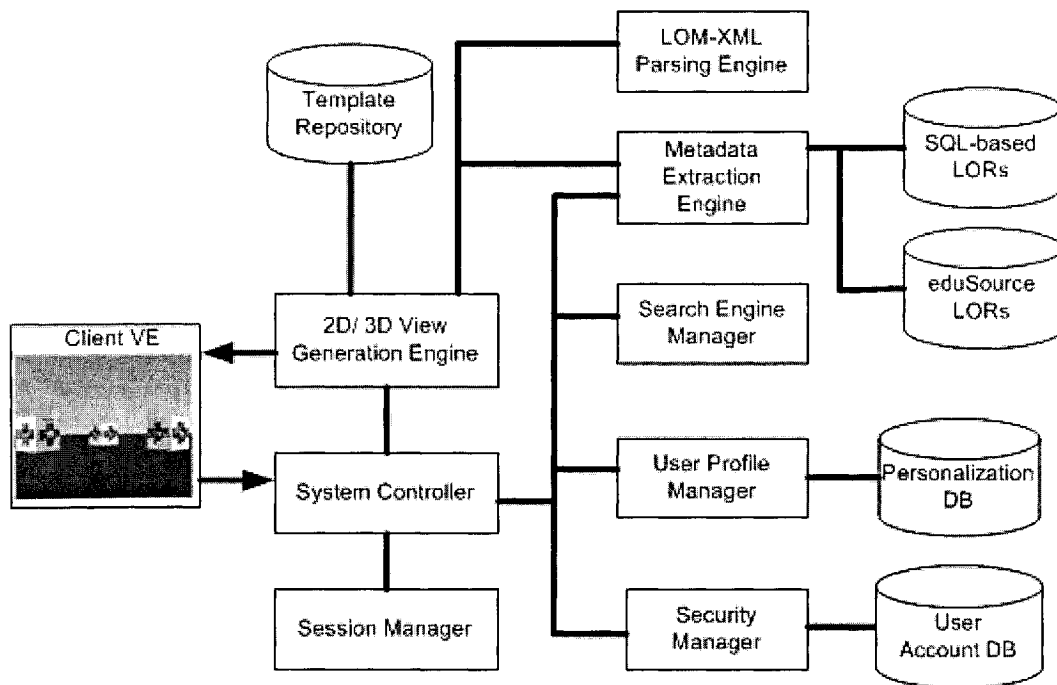

Figure 3.2 High-level architecture of LORNAV

The **User Profile Manager** is responsible for managing individual user profiles, which are stored in the **Personalization DB**. Furthermore, the objects selected by the user while navigating in the VE are also stored in this DB and managed by the profile manager.

The **Search Engine Manager** processes all the search related operations. The search results are aggregated and stored in an XML file to be later used by the 3D View Generation Engine. The search engine manager is invoked by the search interface, which is a 2D user interface generated by the 2D/3D view generation engine.

The **Metadata Extraction Engine** is the module that actually extracts all the necessary metadata records from the remote or local repositories. LORNAV uses **eduSource LORs** [72] as the remote repository that holds the LOM records for LOs. These repositories are accessed using web service interface. There are also **JDBC-based SQL**

**LORs** that hold LOM records and are accessed via JDBC interface over HTTP. The Metadata Extraction Engine receives the LOM records as XML streams and stores them in a XML file.

The **LOM-XML Parsing Engine** is responsible for parsing the LOM-XML file created by the Metadata Extraction Engine. This module is invoked by the 3D View Generation Engine to generate the 3D world for the user.

The **Template Repository** holds the 3D templates designed for objects to be represented in a 3D environment. This is actually a file system which manages the template definitions that are created using modeling language like VRML.

The **2D/3D View Generation Engine** is responsible for creating the dynamic 3D environment and for populating that environment with the 3D representations of the LOM records. It also defines the interactivity of the 3D objects within the VE. This module uses the functionality of several other modules to receive the data from the repository and to create a final 3D view for the user. The engine also generates the necessary 2D interfaces for search and other operations.

The **Client VE** is the client virtual environment rendered on the client machine on the browser. The clients need to install a special plug-in in their browser to actually view the 3D environment.

#### **3.1.4 Features**

The prototype tool LORNAV adheres to the above architecture in order to provide the following highlighted features:

- Visualizes LOs represented in IEEE LOM standard. The use of standard metadata makes it more portable and interpretable.
- Retrieves LOM records from distributed repositories and displays the 3D representations of the result in virtual environment.
- Defines data access mechanism that uses both web services based XML-SOAP and JDBC-based SQL interface.
- Maintains individual user profile for end-user customization. The profile reflects user preference and is used to deliver personalized learning objects in client 3D environment.
- Enables users to perform keyword-based and element-level searches by specifying repositories from the available ones.
- Uses several visual metaphors to display search results.
- Allows user to perform several interaction tasks in the 3D environment. He/she is able to see the associated metadata of an object, play a movie from within the VE, select an object, or read the detail content of the associated object with appropriate plug-ins.
- Provides users with a personal space in the 3D environment where he/she can view previously selected objects.
- Stores the current viewpoint of the navigating user to facilitate return to the same location after any user-performed refreshing action.
- Follows standard model-view-controller (MVC) approach to facilitate modularity and extendibility.
- Supports visualizing Dublin Core [67] and SCORM [68] through a mapping mechanism as an extension of the system.
- Allows developers to plug in alternate visualization metaphors by reusing the data access interface and mapping mechanism.

## 3.2 Three Dimensional Visualization and Navigation

### 3.2.1 Visual Metaphors

Visual metaphors are the mapping between data and visual models. It is very crucial to have a suitable metaphor to visualize and understand information presentation. Many researchers have stressed the importance of finding appropriate information space metaphors for effective information visualization [4, 2, 1]. Similarly, the need for appropriate metaphor is also important for 3D visualization. Several attempts to use different types of metaphors have been made, varying from familiar real life metaphors such as Web Forager [31] shown previously in Figure 2.7 and 3D room [1] shown in Figure 3.3 to more abstract ones such as Cone Trees [48] shown in Figure 3.4.

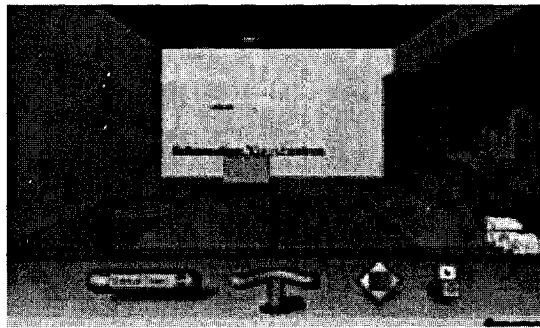

Figure 3.3 3D-Room information space metaphor

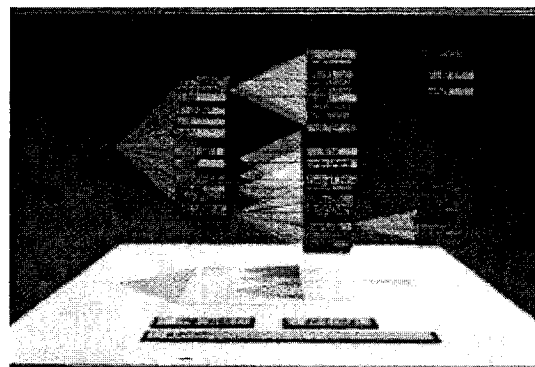

Figure 3.4 Cone trees

The use of one metaphor over the other sometimes depends on the size of the data being visualized, such as cone trees become very large with approximately one thousand nodes and they lose their effectiveness as a result of visual clutter [1].

Motivated by the above and other research, the requirements of the visual metaphors to be used in LORNAV have been analyzed. The use of several metaphors has been investigated varying from familiar real life metaphor such as bookshelf and table to some new metaphors from the game industry such as car driving.

One major concern is that this research cannot use any static metaphor due to the large number of returned LOM records from distributed repositories. On the other hand, it is not quite feasible to display all the results in 3D environment at the same time, which would cause visual clutter and heavily degrade the rendering performance. This led to the adoption of an approach we thought would be suitable for our case. Firstly, all the metaphors are generated dynamically. Secondly, several techniques provided by the modeling language are used, such as sensors, level-of-details, and links to control the number of displayed objects at a given time.

Figure 3.5 shows a metaphor consisting of box geometry. Here the four surfaces of the box are used as the data area leaving top and bottom surfaces unused due to user's viewing perspective. Each surface would contain four 3D objects representing four LOM records. Once one box is filled with dynamic data, the next will be generated and so on by following a pattern.

Figure 3.6 shows another metaphor consisting of familiar real-life objects such as bookshelf and table. Each bookshelf would contain sixteen objects and each table would contain eight objects as a representation of LOM records. Once one bookshelf is filled with dynamic data, the next (bookshelf or table according to a pattern) will be generated and so on.

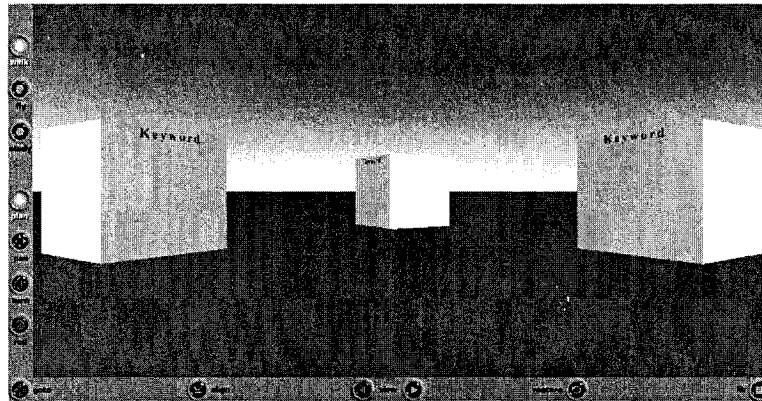

Figure 3.5 Sample new box metaphor

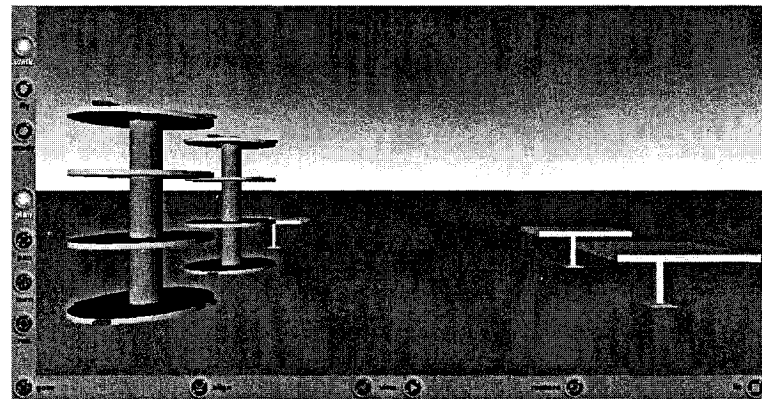

Figure 3.6 Sample familiar metaphor

There are some other metaphors as well in our system, and more can be added easily as the system components are separately defined.

### 3.2.2 Templates of 3D Objects

We use several templates of 3D objects to design the 3D environment. The use of template is a feature provided by the 3D modeling language. In our case, we use the capability of VRML to define prototype using PROTO [58]. PROTO is a way of reusing code to create reusable objects. This allows the encapsulation and

parameterization of 3D objects and/or their behaviors [62]. For example, if we need five boxes with different color we can create the box with a variable color parameter.

The definition of a PROTO can be instantiated from within the same VRML file or from outside the main VRML file. The use of PROTO within the same file is straightforward. On the other hand, PROTO defined outside of the main file can be accessed by VRML's EXTERNPROTO feature. In the following, the basic definitions of the PROTOs that LORNAV uses are provided:

**protoLOM:** This is one of the key templates that is designed to represent a single LOM record. The header definition of this prototype along with the 3D representation is shown in the following Figure 3.7:

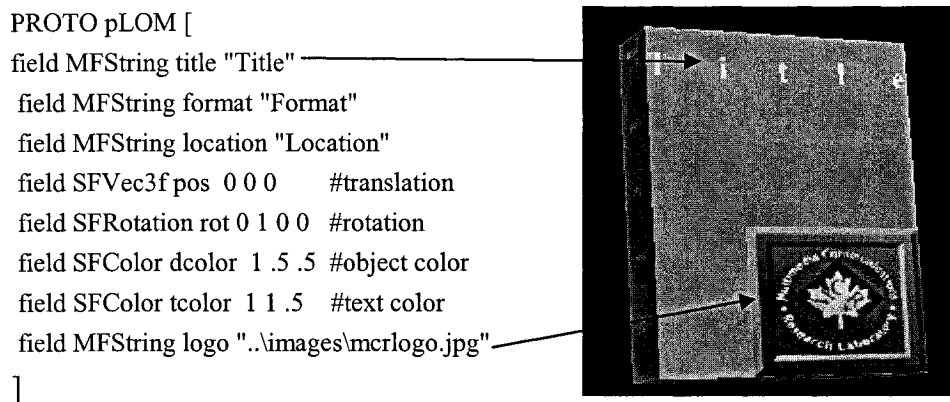

Figure 3.7 Prototype definition and 3D representation of LOM

Figure 3.7 shows the use of several variables (initialized with some value) in the prototype definition that would ensure dynamic characteristics of the 3D objects. The value of these parameters comes from the distributed repositories during the dynamic scene generation process (described in Section 3.2.5). There will be one 3D object for each LOM record retrieved from the repository. Here title refers to the title element of the LO, format refers to the technical format of the LO (e.g. text/html, image/jpeg etc.), and location refers to the http location of the LO. This is followed by pos, rot, dcolor,

and tcolor for setting the spatial positions and some color properties. The remaining variable logo refers to the texture representation based on the value of format variable. Several textures have been used to represent different values of the format variable.

**protoLABEL:** This is another important template that is designed to show the selected metadata elements and their associated values in a LOM record from within the 3D environment. The header definition of this prototype along with the 3D representation is shown in Figure 3.8:

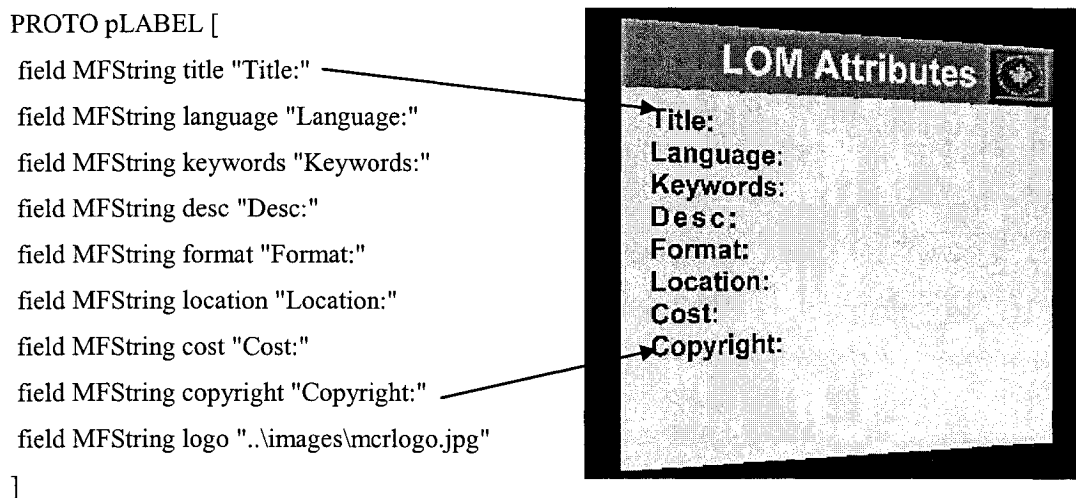

Figure 3.8 Prototype definition and 3D representation of LOM attributes

In the above definition, several variables correspond to different LOM elements. Here again the value of the variables come from the distributed repositories during execution. An explanation of the fact of choosing these elements and not others are provided in the next section.

In addition to the above templates, LORNAV uses several other 3D templates such as box, bookshelf, table etc. These are used to dynamically generate the visualization metaphor described earlier in Section 3.2.1.

### 3.2.3 Mapping LOM Elements to Visualization

According to the IEEE LOM standard [61], nine base categories and more than sixty elements for these categories are used to define learning objects. This huge number makes it impractical for the learning community to properly tag the elements.

Different communities adopted new and innovative ways to define their needs. CanCore [69] for example is an application profile that limits the number of LOM elements to use. This approach is permitted by the base IEEE LOM standard. The use of application profile is discussed earlier in Section 2.1.2.

Table 3.1 Selected LOM elements for visualization

No.	Category	Selected elements	Used for Visualization
1.	General	1.1.1 Identifier.Catelog	
		1.1.2 Identifier.Entry	
		1.2 Title	√
		1.3 Language	√
		1.4 Description	√
		1.5 Keyword	√
2.	Life Cycle	2.3.1 Contribute.Role	
		2.3.3 Contribute.Date	
3.	Meta-MetaData	3.2.1 Meta-Metadate.Role	
		3.2.3 Meta-Metadate.Date	
4.	Technical	4.1 Technical.Format	√
		4.2 Technical.Size	
		4.3 Technical.Location	√
5.	Educational	5.2 Educational.LearningResourceType	
		5.5 Educational.IntendedEndUserRole	
6.	Rights	6.1 Rights.Cost	√
		6.2 Rights.CopyrightandOtherRestrictions	√
7.	Relation	-	
8.	Annotation	-	
		-	
9.	Classification	9.2.1 Classification.Source	

This research identifies eighteen LOM elements from all the element sets. The selection of these elements is influenced by our experience and work done by others in this area.

From these eighteen elements, another subset of eight elements is used for the purpose of visualization. The rest is left for other search, classification and aggregation operations. These elements are listed in Table 3.1.

As shown in Figure 3.7 and Figure 3.8, a number of variable fields defined in the templates are related to the visualization of LOM records. Those fields have a straight one-to-one correspondence with the LOM elements selected in Table 3.1, such as Title corresponds to 1.2 Title, Language corresponds to 1.3 Language and so on.

### **3.2.4 Data Clustering**

Data clustering and categorization is one of the major concerns in preparing 3D environments. As discussed in Section 2.1.6, 3D visualization can offer several benefits such as seeing patterns in displayed data, improved perception, etc. To achieve these benefits, data need to be categorized in different ways. VIBE [18], InfoCrystal [51], and other approaches address the idea of content-based clustering of documents. The ADVIZOR [46] system discusses several well-known design patterns for visual discovery and analysis of data. One such design pattern is named as Overview, Zoom, Filter, Detail on Demand, which in turn is based on [38].

In the case of LORNAV, one of the categorization techniques followed is based on keywords. This way, when the user poses a query consisting of, for example, four keywords, LORNAV categorizes the returned LOM records based on these keywords. The keywords are displayed on top of the object container that would hold LOM records according to its predefined capacity. Several LOM records can be returned for each keyword. In this case, an additional container will be added for the same keyword in the 3D environment.

The other clustering techniques are used based on specific LOM elements, such as Technical.Format. The LOs that are similar in technical format are sub-grouped under the main keyword-based category. There could be further grouping based on Educational.LearningResourceType or Educational.IntendedEndUserRole, or according to any classification system e.g. ACM or IEEE classification systems to show similarities among objects. Furthermore, if considered semantically, the categorization could follow any given ontology for a particular domain.

### 3.2.5 Design of Dynamic 3D View Generation Module

Generating a dynamic 3D world brings life to a 3D environment. Object representations in 3D VE can be based on repositories that are distributed over the network. Figure 3.9 is a sequence diagram that shows the algorithm used by the 3D view generation module.

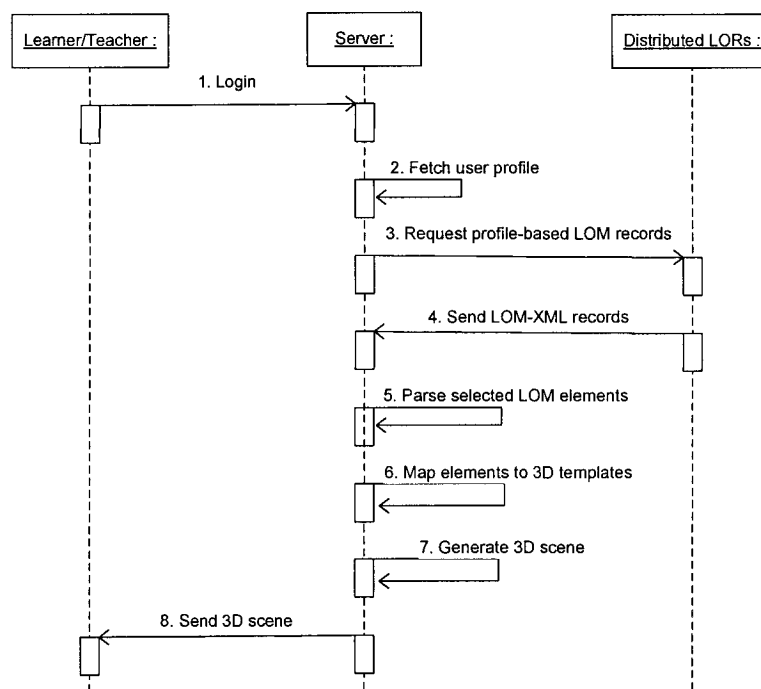

Figure 3.9 Dynamic 3D view generation algorithm

Once a user logs into the system, the server fetches the corresponding user profile. The server then makes an XML-SOAP request based on the profile to the remote web service interface of the distributed LORs in order to receive related LOM records. The remote web service interface in reply sends the LOM records as a LOM-XML stream. Figure 3.10 shows a sample LOM-XML stream that consists of elements from the general, technical, educational and rights categories.

```

<lom xmlns="http://ltsc.ieee.org/xsd/LOMv1p0"
xmlns:lom="http://ltsc.ieee.org/xsd/LOMv1p0"
xmlns:xsi="http://www.w3.org/2001/XMLSchema-instance"
xsi:schemaLocation="http://ltsc.ieee.org/xsd/LOMv1p0
http://explora2.liceftelug.quebec.ca/lomxml/schema/lom.xsd">
  <general>
    <title>
      <string language="en"> Introduction au Java</string>
    </title>
  </general>
  <technical>
    <format>application/pdf</format>
    <location>http://www.inrs-telecom.quebec.ca/tel270/doc/res/intojava.pdf</location>
  </technical>
  <educational>
    <intendedEndUserRole>
      <source>LOMv1.0</source>
      <value>Teacher</value>
    </intendedEndUserRole>
    <intendedEndUserRole>
      <source>LOMv1.0</source>
      <value>Learner</value>
    </intendedEndUserRole>
  </educational>
  <rights>
    <copyrightAndOtherRestrictions>
      <source>LOMv1.0</source>
      <value>yes</value>
    </copyrightAndOtherRestrictions>
    <description>
      <string language="x-none">Étudiants de l'INRS ou de l'ÉTI</string>
    </description>
  </rights>
</lom>

```

Figure 3.10 Sample LOM-XML stream

Upon receiving the reply, the server parses the required metadata elements from the LOM-XML stream. It then uses the predefined 3D templates of LOs and metaphors, dynamically associates the metadata with the templates and finally generates a 3D virtual environment scene. The 3D scene is then transferred back to clients for rendering.

### **3.2.6 Navigation Model**

The navigational model focuses on client activities pertaining to the overall 3D environment. However, some client activities may require server interactions for processing requests, such as the Search operation.

In LORNAV, learning objects retrieved from distributed learning object repositories are presented in the 3D environment over the Web. Users navigate the 3D world with the mouse input interface. The use of joysticks, gesture recognition and other haptic devices would be interesting to explore in the future.

The navigation model of LORNAV includes several navigational tasks that a user currently performs. This model is shown in Figure 3.11 followed by a brief description of each of the tasks.

**Visual Exploration:** This allows user to navigate around the 3D world without any predefined purpose or destination. Users often perform such exploration tasks to become familiar with the 3D world.

**Metaphor Selection:** LORNAV provides multiple visual metaphors to present the learning objects of interest. The use of multiple metaphors helps user to better understand the presented information.

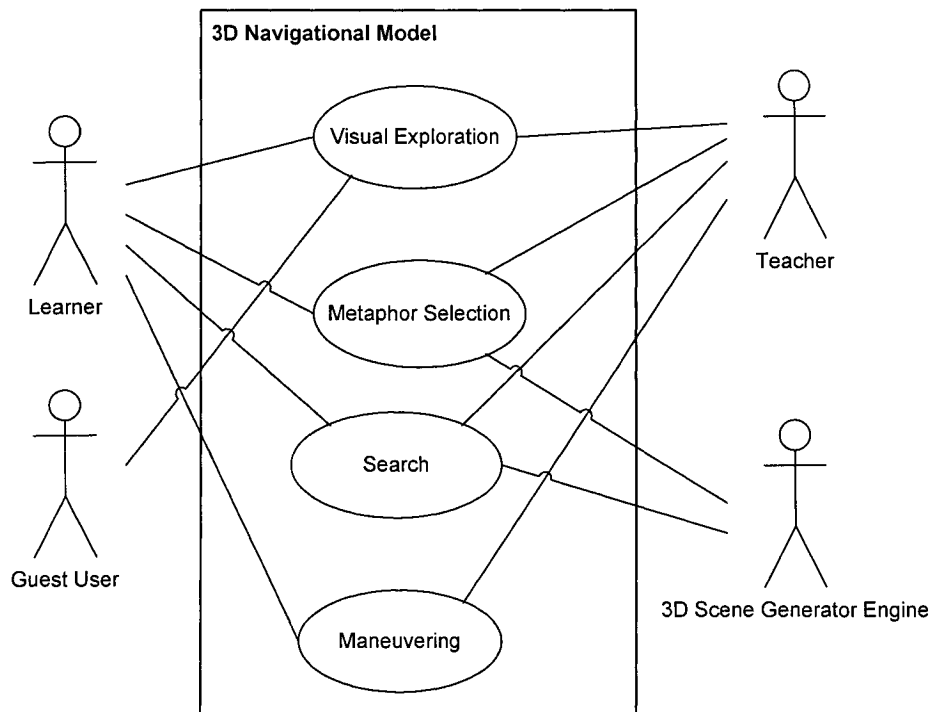

Figure 3.11 Use case of LORNAV navigational model

**Search:** This operation is used to find specific learning objects. The search interface is a 2D-based interface. A user can perform two types of searches: keyword-based search and element-level search. In keyword-based search, the user types several keywords separated by commas and choose the target repositories on which to perform the search. Similarly in an element-level search, the user specifies search criteria for selected LOM elements and chooses the target repositories to carry the search operation. The server retrieves matching LOM records from the repositories and generates the dynamic 3D world for the user to navigate further.

**Maneuvering:** The maneuvering tasks are often performed to get new insight or understanding of the environment [42]. LORNAV defines several viewpoints while generating the 3D environment. Users are able to change these viewpoints at the time of exploring the 3D environment.

### 3.2.7 Interaction Model

The interaction model involves client activities performed on the 3D objects and artifacts displayed in the 3D environment. Interactions in the 3D environment with the objects may be challenging, especially when the user uses 2D mouse interface [49]. LORNAV foresees the use of multiple haptic based devices for better interaction in the future. Figure 3.12 represents a use case diagram for the current interaction tasks that a user can perform with the 2D mouse interface.

**Touch Object:** While navigating in the 3D world, a user can touch an object by putting the mouse on top of it. This allows him to see selected metadata attributes associated with that object. The metadata are shown in a 3D panel. If the user is interested in that object, he can perform other operations. When the user removes the mouse from the object, the metadata panel disappears. LORNAV uses the capability of VRML's touch sensor to provide this functionality.

**Click to View:** While viewing the metadata of an object, a user can perform a mouse-click to view the content of the learning object. The learning content may be viewed on an internal or external viewer based on the actual content type. Some of the media types such as movie, video, sound, image etc. are played from within the 3D environment, while others such as pdf, html are viewed in external viewers.

**Select Object:** The clicking on an object is also treated as selection of that object. This idea behind this functionality is that the user became interested and hence clicked on that object to view its content. The object's metadata information are then stored in separate database. In the next visit the selected objects are viewed in 3D within a personal space defined by the view generation module.

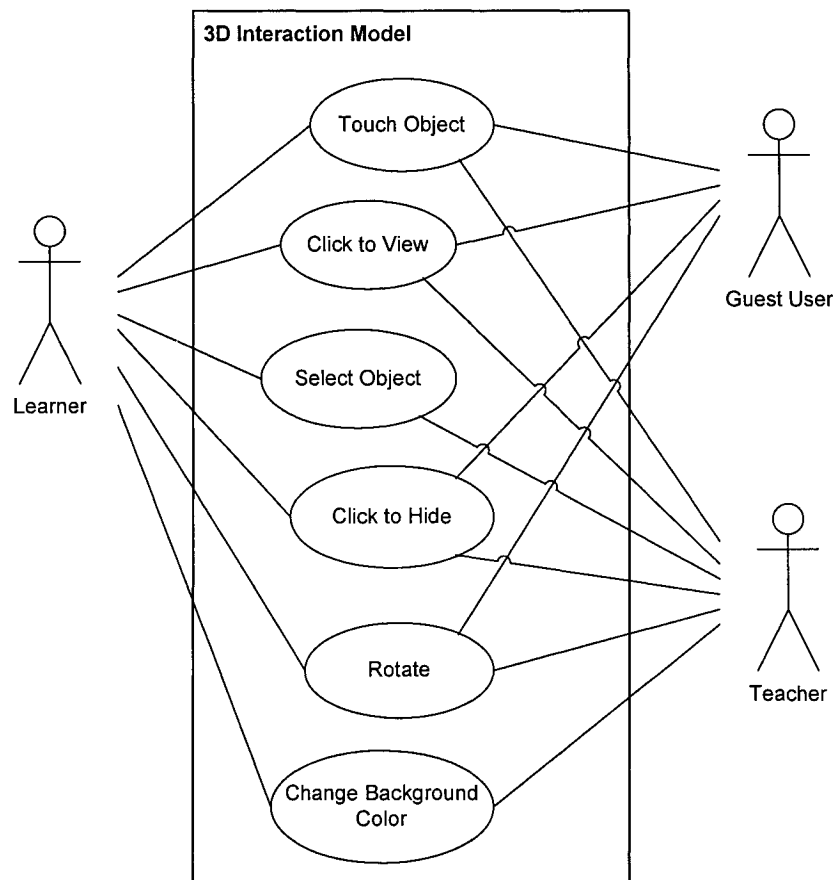

Figure 3.12 Use case of LORNAV interaction model

**Click to Hide:** The click to view and click to hide operations are similar to flip-flop events. The objects that are played from within the 3D environment by mouse-click event are hidden by the next mouse-click event.

**Rotate:** The 3D representations of LOs are organized in the 3D environment through the use of containers such as shelves, tables, or boxes. These containers can be rotated by the user to view objects that are arranged on the opposite sides of the user's current viewpoint.

**Change Background Color:** LORNAV uses several color properties for background color. A user is able to switch between different background colors for the 3D world by using custom defined buttons.

### **3.3 Personalization of 3D Environment**

#### **3.3.1 Personalization Requirements**

Personalization is an attempt to address the interest and preference of an individual user. This offers user satisfaction and customer loyalty in e-learning, e-commerce and many other domains. The need for personalization is widely addressed in many literatures [54, 41]. We continue our focus to address the need for personalization in three dimensional virtual environments.

Any 3D environment with a large information space may suffer from occlusion and slow rendering performance. This issue, along with the demand for providing personalized content of interest to the user, raises the need for adopting personalization in 3D environment. Several researches aimed at personalizing 3D e-commerce or online virtual stores. The ENTER system [13] adopts an agent based approach to maintain a user profile that is created by the user on initial login. It monitors the user activities and automatically updates the profile with new information. This information acts as a basis for the creation of a personalized 3D environment for the current user. Another similar work presented as AWE3D architecture [32] records the user interactions with the 3D world and generates the subsequent world according to this recorded interaction data. While these approaches remain as a basic idea of providing personalization in our system, we added some extra functionality to enrich the personalization module.

Unlike the above systems, LORNAV focuses on an e-learning domain and aims at visualizing learning objects that are of interest to the learner or teacher. This has been

facilitated through the use of a personalization mechanism that maintains individual user profile. The profile contains several criteria to be entered by the user. The use of a profile ensures that the 3D environment is never overloaded with unrelated objects.

### 3.3.2 Personalization Profile

Each registered user may have his/her profile in the system. The profile contains predefined information needed to be entered by the individual user. Figure 3.13 shows an XML excerpt of a user profile.

```
<?xml version="1.0" encoding="UTF-8"?>
<userprofile xmlns="http://www.mcrlab.uottawa.ca/lornav">
...
<userid>Sabrina</userid>
<keyword>Java Programming</keyword>
<keyword>XML</keywords>
<language>English</language>
<format>image/jpeg</format>
<format>video/mpeg</format>
<learningResourceType>Figure</learningResourceType>
<learningResourceType>Exercise</learningResourceType>
<copyright>NO</copyright>
...
...
...
</userprofile>
```

Figure 3.13 An XML excerpt of user profile

The XML excerpt eventually shows that a user is able to specify his/her area of interest along with other attributes to personalize the environment.

### 3.3.3 Design of Personalization Module

LORNAV's personalization module maintains separate profile for each individual user. These profiles are used by the 3D visualization module to provide personalized 3D environment to the user. The user can navigate in this environment and select the

learning objects of interest to review on subsequent visits. However, a user is not bound by the choices he/she made in his/her profile. He/she can invoke the search interface for additional learning objects to be displayed in the 3D environment and similarly perform navigation and selection operations. Figure 3.14 shows the algorithm for the profile-based personalization process.

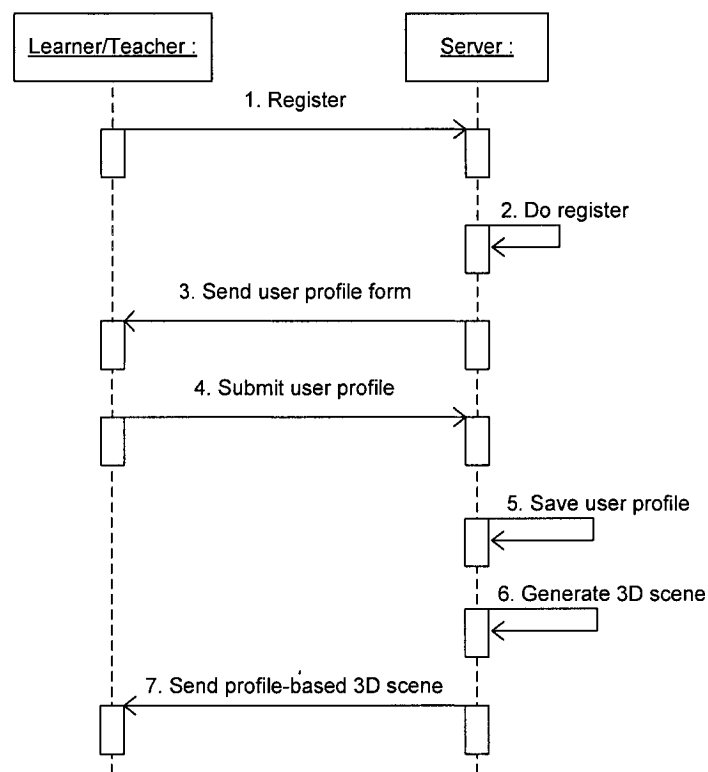

Figure 3.14 Profile-based personalization algorithm

When any user logs into the system for the first time, he is presented with an empty form to enter some selection criteria that includes his choice of subject area, choice of language, choice of data format, etc. These criteria are then stored as the user profile in a profile database. The already registered users can modify their existing profile anytime they need. The server constructs the query based on this user profile and submits that query to the distributed repositories to retrieve data of the matching

learning objects. Based on this data, the server constructs a 3D scene and sends that to the client browser for rendering.

Figure 3.15 is an extension of profile-based personalization algorithm. Through navigation in VE, the objects explored by the user are stored in the profile database. The next time the user enters the system, those previously selected objects are displayed in a personal space within the 3D environment along with the objects retrieved based on the profile. Obviously the common objects are displayed just once in the personal space. The idea of providing personal space is also recommended in [9].

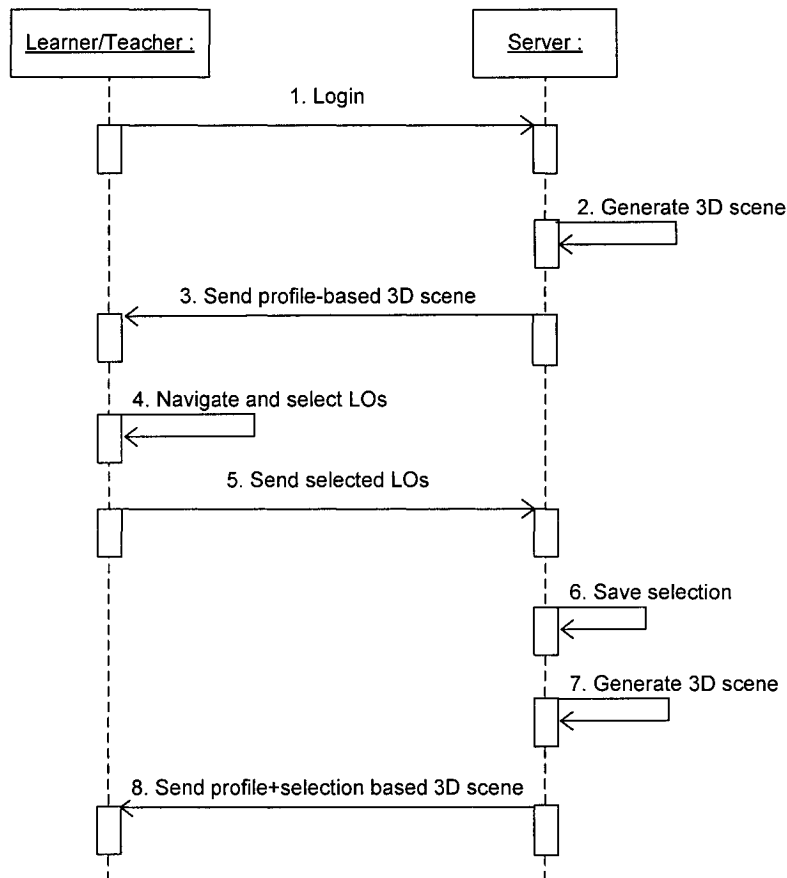

Figure 3.15 Selection-based personalization algorithm

At the moment, the retrieval of data from the distributed LORs is done using queries to perform exact matching search. However, in the future there will be some kind of fuzzy matching algorithm to retrieve learning objects with similar concepts.

### **3.4 Data Access**

#### **3.4.1 Data Source and Access Interface**

LORNAV attempts to visualize LORs that adopt LOM standard to describe LOs. The LORs may either be distributed over the network, or may reside in the server. These are described in the following:

- The distributed repositories we use are the eduSource [72] LORs that store and maintain LOM [61] records. The types (Relational SQL DB, XML DB etc.) of these LORs are unknown since they are maintained by the individual educational communities. However, they have a common web service based federated search interface to access the data. The federated search allows the user to pose a single query in order to receive data from multiple repositories.
- The local LOM repository is based on a MySQL database. It can be connected by using the Java Database Connectivity (JDBC) tool. The database connectivity parameters are stored in separate property files in text file format and are easy to update. The database platform is very transparent, meaning that one can easily change the database platform from MySQL to Oracle or SQL Server simply by changing parameters in the property files. Search on this database can be performed only with standard SQL statements. Although this repository is locally stored in the server, it can be distributed as well because the access to this repository is done via HTTP protocol.

### 3.4.2 Data Access Strategy

There are a number of ways that can be adopted to access the distributed and/or local LOM repositories. An overview of several data access strategies can be found in [6, 35]. The key idea of data access is to provide search functionalities to search the LORs. LORNAV implements three kinds of search strategies which are described in the following:

- **Complete search** of LOM records without specifying any conditions. This is the case when a user logs into the system but does not wish to create his/her profile. While adopting this strategy, a practical design choice is made by limiting the number of LOM records to be retrieved to few hundreds. However, the number may be adjusted from the admin profile. The choice of limiting the number enables faster display of the results in the 3D environment without any visual clutter.
- **Implicit user profile based search.** This case arises when a user (learner, teacher, etc.) specifies several criteria reflecting his choices. The search is performed based on this user profile to retrieve the LOs that are of interest to the user.
- **Explicit search.** In this case the user explicitly invokes the LORNAV search interface in order to search additional LOs that are not currently being displayed in the 3D environment. The search can be performed either by specifying keywords, or by specifying preferred values for certain LOM elements. The results of the search are then displayed in the 3D world by the LORNAV's 3D view generator engine.

### 3.4.3 Design of Data Access Module

The main aspect of the data access module is to keep the access interface completely separate from the view generation process so that any additional repository can be

plugged-in with little effort without affecting the views. This ensures smooth visualization of LOs even if some of the repositories are not active at a given time.

Figure 3.16 shows a conceptual diagram of the data access request.

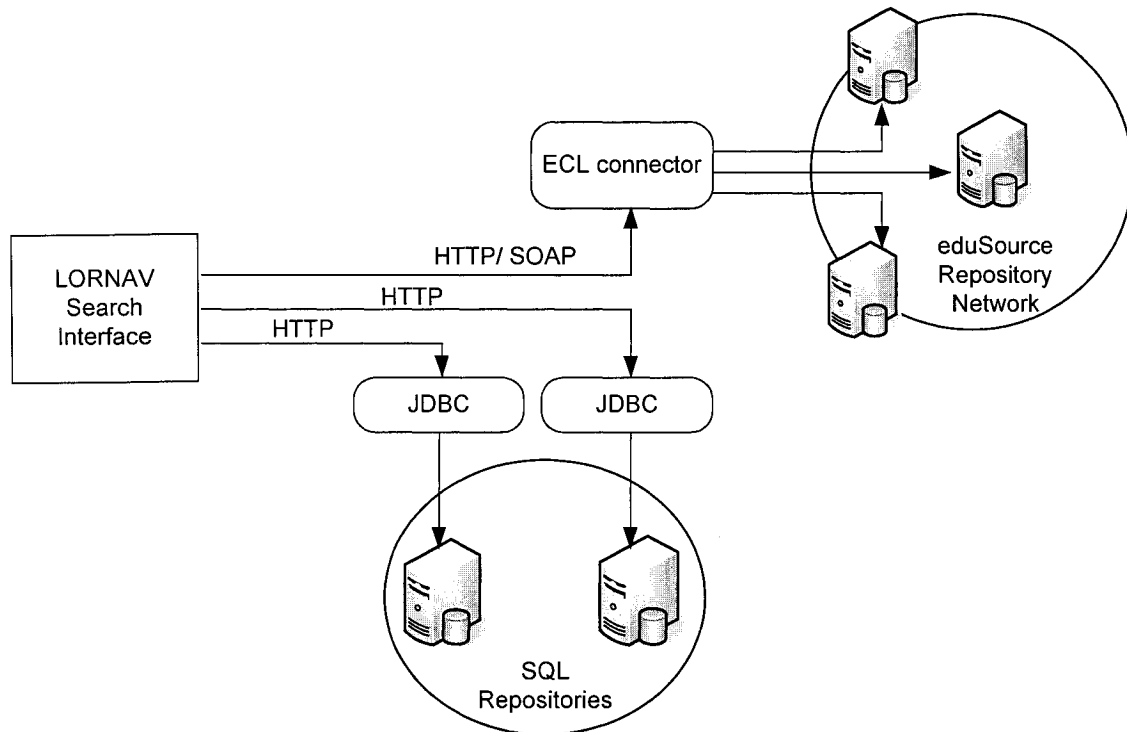

Figure 3.16 Typical search request

Figure 3.16 shows that the data access module is capable of handling multiple sources of repositories. The eduSource LORs [72] are accessed using the eduSource Communication Layer (ECL) connector [60, 39]. The connector provides standard API to connect and query existing repositories to the eduSource network. There are also relational SQL repositories that are accessed using the JDBC connectivity tool over the Internet.

In response to the data access request, the APIs of the repositories send replies with the matching LOM records. As the repositories are physically distributed, there is a need to aggregate the retrieved LOM records. The aggregate data then goes straight into the

LORNAV's 3D visualization engine to produce the 3D visualization in the virtual environment. Figure 3.17 shows a conceptual diagram of data aggregation in LORNAV.

Figure 3.17 portrays that the web service based eduSource LORs return LOM records as an LOM-XML stream. On the other hand, the JDBC-based SQL LORs initially retrieve LOM records as ResultSet object by using SQL query. In order to aggregate these two kinds of data format, LORNAV first converts the ResultSet object into an XML stream of LOM records, combines these stream to those of eduSource stream, and stores them as an XML file. This file is used by the visualization engine and parsed to separate the required LOM elements by the LOM parser. The parsed element sets are then used by the visualization engine to generate the 3D virtual environment, which are transferred to the client's browser.

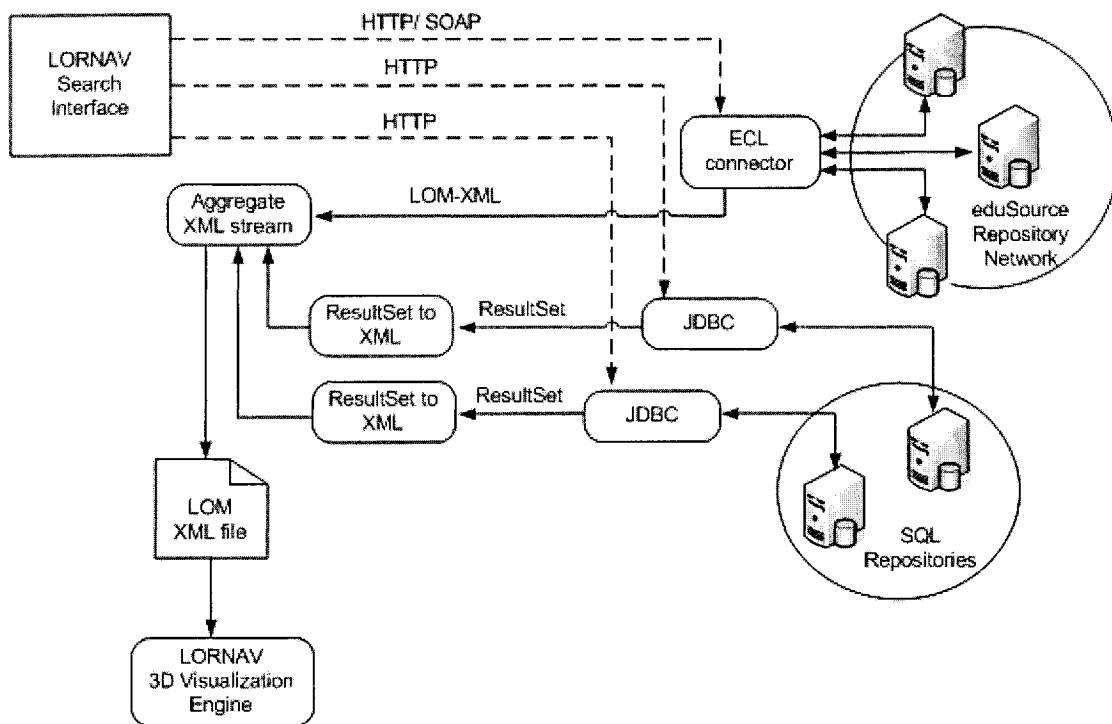

Figure 3.17 Data aggregation

### **3.5 Summary**

This chapter covered the core design phase of LORNAV. It began by providing a use case model and high-level system architecture along with the system features. It then gradually presented the algorithm and rationale behind the design. The 3D visualization and navigation phase is described by focusing on the visual metaphor, 3D templates of objects, mapping between LOM elements and visualization, data clustering and dynamic view generation. The personalization of 3D environment phase is described by stating the personalization requirements followed by personalization profile and the design of profile-based and selection-based personalization algorithm. Finally the data access phase is described in light of data source and its interface, data access strategy and typical search and data aggregation algorithm.

## Chapter 4

### Implementation

The prototype system LORNAV has been implemented using the design concepts described in the previous chapter. This chapter presents the actual implementation process of LORNAV.

#### **4.1 Technology Requirements**

LORNAV is built with as much open source software as possible. As it is a web based tool, several web technologies are considered. The following summarizes a list of technologies that have been investigated and used in order to implement LORNAV:

- Apache Tomcat 5.0.x as Web and Application Server  
(<http://jakarta.apache.org/tomcat/>).
- Servlets and JSPs as Active Server Components that come as part of the Tomcat server.

- Java Development Kit 1.4.2\_02 for building java classes (<http://java.sun.com/j2se/>).
- MySQL Database 4.1.7 as server database (<http://dev.mysql.com/downloads/mysql/4.1.html>).
- MySQL Java connector 3.1.x for database connectivity (<http://dev.mysql.com/downloads/connector/j/3.1.html>).
- VRML97 as 3D modeling language (<http://www.web3d.org/x3d/specifications/vrml/>).
- VRML97 Plug-in to render VRML model in the browser (<http://www.parallelgraphics.com/products/cortona/>).
- MS Internet Explorer 6.0.x and/or Netscape browser as client navigation tool.

## 4.2 Development of Software Architecture

The software architecture of LORNAV has been implemented using a standard software development process. It is a three tier client-server based tool that operates on the web environment. Its architecture is based on the MVC [53] pattern, which has the potential to increase system performance, flexibility, maintainability, reusability, scalability and interoperability while hiding the complexity of the distributed processes from the user [77, 53]. In Figure 4.1 we provide the actual software architecture of LORNAV as an extension of the high-level architecture previously shown in Figure 3.2.

**The client tier:** The client tier provides a browser-based 3D virtual environment where the user navigates and interacts with the displayed learning objects. The 3D user interfaces are implemented using VRML97. The client browser requires additional plug-in to support rendering the VRML scenes. LORNAV uses the Cortona VRML plug-in [64] from parallel graphics.

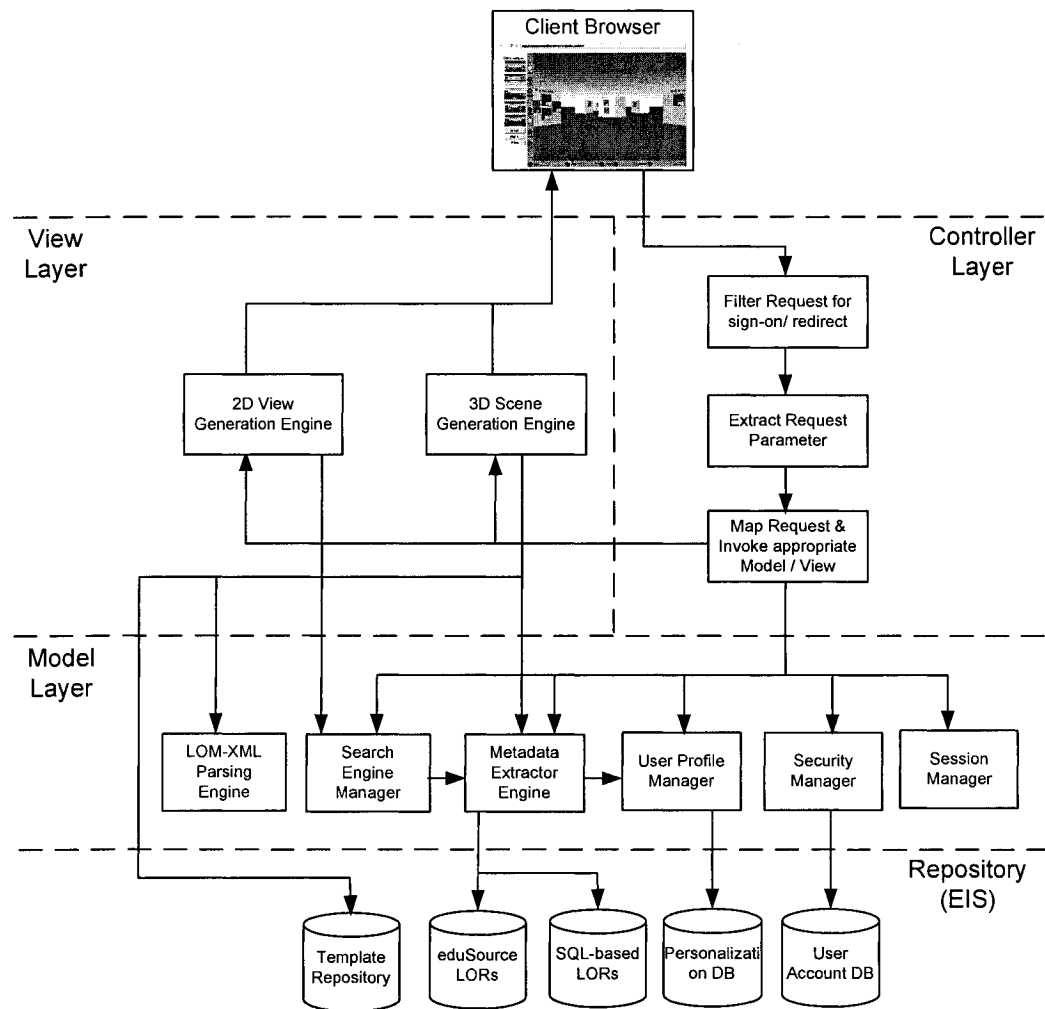

Figure 4.1 Model-View-controller Architecture in LORNAV

While developing LORNAV, the VRML External Authoring Interface (EAI) [59] has been bypassed to communicate with the 3D scene and instead active server side components have been used to dynamically generate and manipulate the 3D objects. The reason behind this is that the VRML EAI only relies on Microsoft VM which is based on java 1.1 and does not support Servlets, JSPs and web services technology that we have used.

**The web tier:** This is based on the MVC pattern. The **Controller** in this architecture is the core component. It controls the flow of the application and serves as the join between the model and view. We have used several active components (e.g. Java Servlets) for processing HTTP requests coming from the clients. The **Model** layer encapsulates the business objects and API for the application's functionality. There are several models in LORNAV architecture that includes Security Manager, Session Manager, User Profile Manager, Search Engine Manager, Metadata Extraction Engine, and LOM-XML Parsing Engine. These modules are implemented using series of Java classes and servlets. We have developed a custom built LOM-XML parser that uses the Simple API for XML parser (SAXParser). The remaining functional unit is the **View** layer that is mainly responsible for presenting data to the user. The View layer includes the 2D and 3D View Generation Engine. These are implemented using JSPs. The idea of generating 3D views as VRML scenes using JSP pages is illustrated in [75]. The 3D View Generation Engine uses 3D templates stored in the template repository and populates them with dynamic data to generate dynamic views.

**The EIS tier:** This is composed of several local and distributed LOM repositories, Personalization DB, User Account DB, and 3D template repositories. The dynamism of the 3D scenes is based on the data stored in the LORs.

The software architecture of LORNAV supports both HTTP and HTTPS protocol for the communication between client and server. The HTTPS protocol takes care of secure communication between the LORNAV server and the client browser.

### 4.3 Example Interfaces

The implementation of LORNAV resulted in a number of user interfaces. This includes both 2D and 3D interfaces. The 2D interfaces are used for user input parameters such as entering login information, setting up the user profile, entering search parameters, and

administering the system. The 3D interface is the 3D environment that is rendered on the client's browser. The 3D environment is populated with the LOs retrieved from the distributed LORs. All these interfaces can be classified into two types such as navigational interfaces and interaction interfaces. The classification comes from the fact that the user performs either navigational or interaction tasks in the 3D environment.

#### 4.3.1 Navigational Interfaces

Figure 4.2 shows a sample screen shot when a user logs in the system using a metaphor containing square boxes. Each side of the box contains four objects representing four LOs. When the user navigates in such an environment, he/she can rotate the box to see the objects in other sides of the box. As an alternative to this, he/she can walk through and see the objects in other sides. Each box represents the objects with similar keywords. However, if the number of objects related to a keyword is more than a box can contain, another box will be dynamically created to contain the additional objects.

The 3D environment shown in Figure 4.2 corresponds to the user profile settings of a particular user if the profile exists; otherwise first few hundred LOM records are displayed in this environment. In the figure, the user is given several choices including selecting a metaphor from the available metaphors, searching LOs of choice, entering or updating his/her profile, and administering if applicable.

Figure 4.3 shows the screen that appears after the user selects another metaphor created dynamically using familiar objects such as shelf and table. In this view, the user can rotate the shelf and/or table by walking close to it and use the mouse to go in the XY plane while holding it down. The user can also change the background color using the 3D switch in the virtual environment.

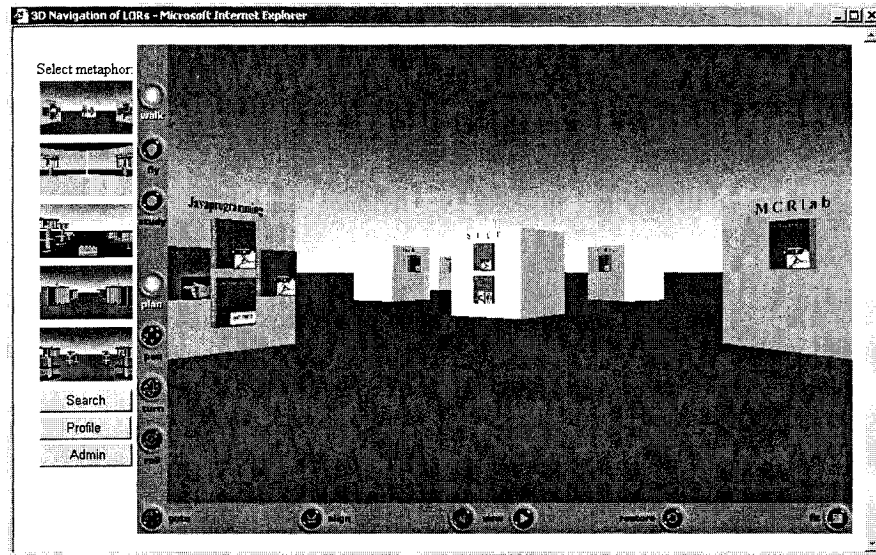

Figure 4.2 Sample 3D environment in a new box-type metaphor

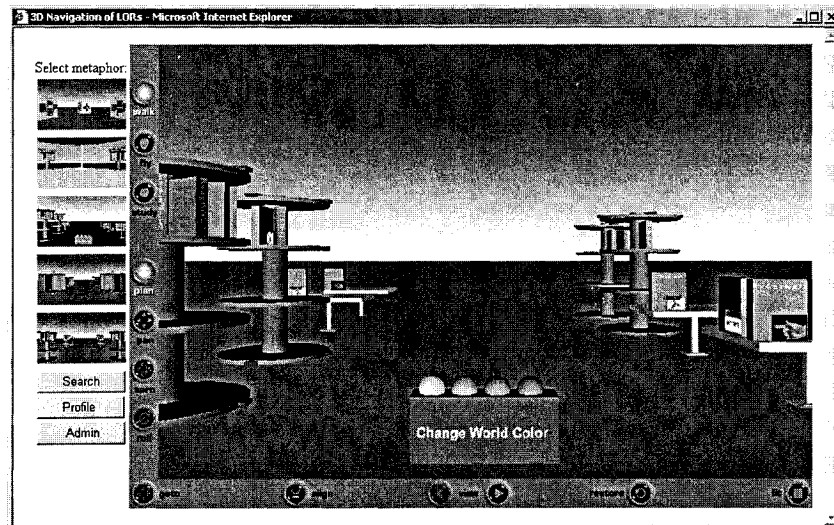

Figure 4.3 Sample 3D environment in a familiar metaphor

Figure 4.4 shows a 2D interface when the user selects the search option. The user is able to search either by specifying multiple keywords or specific LOM elements such as title, format, and description and eventually on remaining LOM attributes. He can also specify which repository he wishes to include in the search. After submitting his

selection criteria, he is provided with the search results displayed in the 3D environment similar to Figure 4.2, Figure 4.3 or in any other selected metaphor.

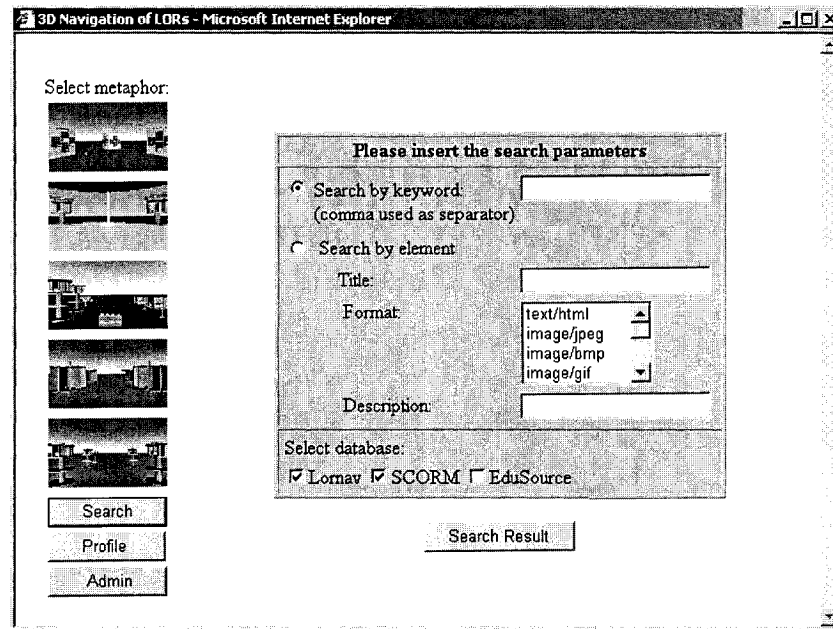

Figure 4.4 Sample search interface

There are other navigational interfaces such as user profile entry interface, admin interface, and 3D metaphors. The sample screen shots of these interfaces are not presented here, but are available in the software prototype of LORNAV.

#### 4.3.2 Interaction Interfaces

Figure 4.5 represents a sample interaction interface for touch and click interaction. There is a TouchSensor attached to each of the 3D objects. When the user touches an object (by taking the mouse on top of the object) the TouchSensor event is activated which uses the **protoLABEL** (shown in Figure 3.8) prototype to show the metadata associated with that object. If the user feels more interested in that object, he can click on that object to see the content. In the figure, the user touched an image object

representing a LO and clicked on that to see the real image from within the 3D environment. The clicking also refers to the user's preference towards that object and hence, the metadata of that object is stored into a separate database to be viewed on subsequent visits. If the user moves the mouse the metadata information will be hidden. In the case of an mpeg movie, the situation would be the same as VRML browser supports playing mpeg movie from within the VE.

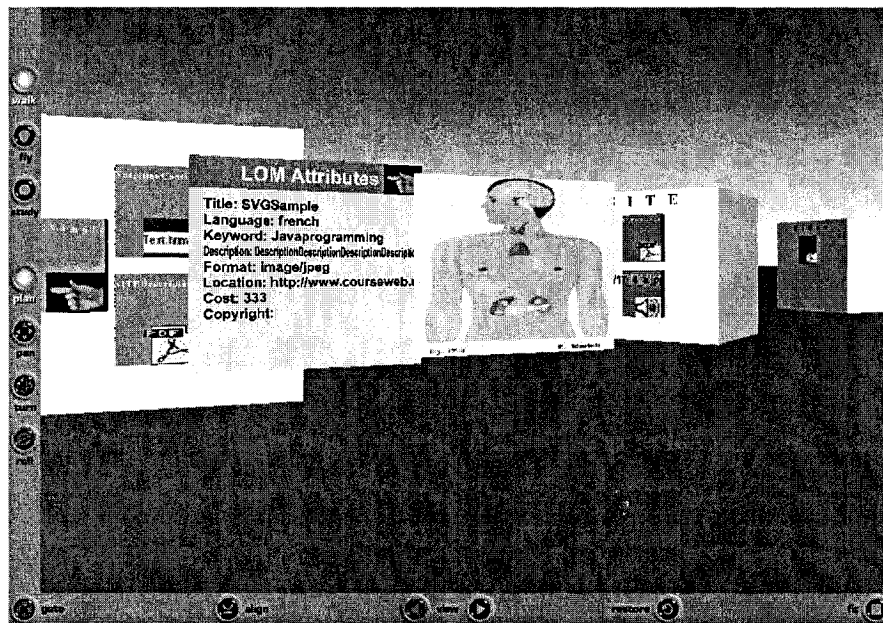

Figure 4.5 Sample interface for touching and clicking a LO of type image

Figure 4.6 shows another interface for touch and click interaction in the case of an HTML document. Unlike an image, or movie object, the html document is opened in a separate browser. VRML does not support all types of media objects to be played or viewed from within the 3D environment. However, those objects can be viewed using external plug-in such as real player or windows media player.

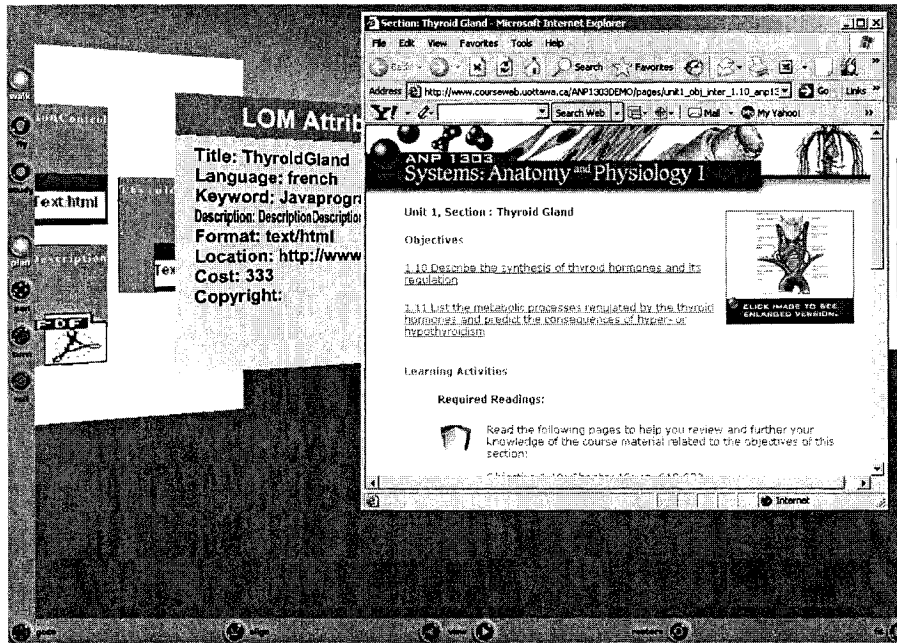

Figure 4.6 Sample interface for touching and clicking a LO of type html

#### 4.4 Summary

This chapter covered the issues related to the implementation of LORNAV. At first it summarized the different technologies needed to develop the system. It then provided the software architecture of LORNAV and described the individual components in the architecture. The chapter concluded by presenting some screen shots of navigational and interaction interfaces.

## Chapter 5

### Evaluation

In this chapter, the evaluation of LORNAV tool is presented. The evaluation is based primarily on the usability aspects of the system for it being a 3D visualization and navigational tool. Although information visualization is a rapidly emerging research field, very few [50, 34, 52, 47] have actually addressed the issue of usability study specific to VE. An attempt at leveraging these researches has been made in order to evaluate LORNAV and analyze the result.

#### **5.1 User Studies**

User studies of any visualization system can provide valuable insight about the qualitative and quantitative data. Qualitative data may be collected through questionnaire and interviews, whereas quantitative data may be gathered by measuring task performance, user ratings on different questions and so on [49]. Such information has been gathered by using existing usability tool such as MAUVE [34], which focuses on multi-criteria assessment of usability for virtual environment. The use of MAUVE

allowed us to focus on enhancing the system functionality and performance more than preparing the test questionnaire and environment. As evaluating any 3D environment is somehow different than evaluating traditional web sites or applications, and usability evaluation of virtual environment is a research area in its entirety, the selection of an existing tool justifies our action.

Research related to VE usability and design guidelines suggested two different areas of VE system usability that includes VE system interface and VE user interface [34]. The VE system interface refers to software, hardware, and overall man-machine interaction design. On the other hand, the VE user interface addresses physiological, psychological, and psychosocial issues. Figure 5.1 gives an overview of the usability criteria that may be assessed by the MAUVE system.

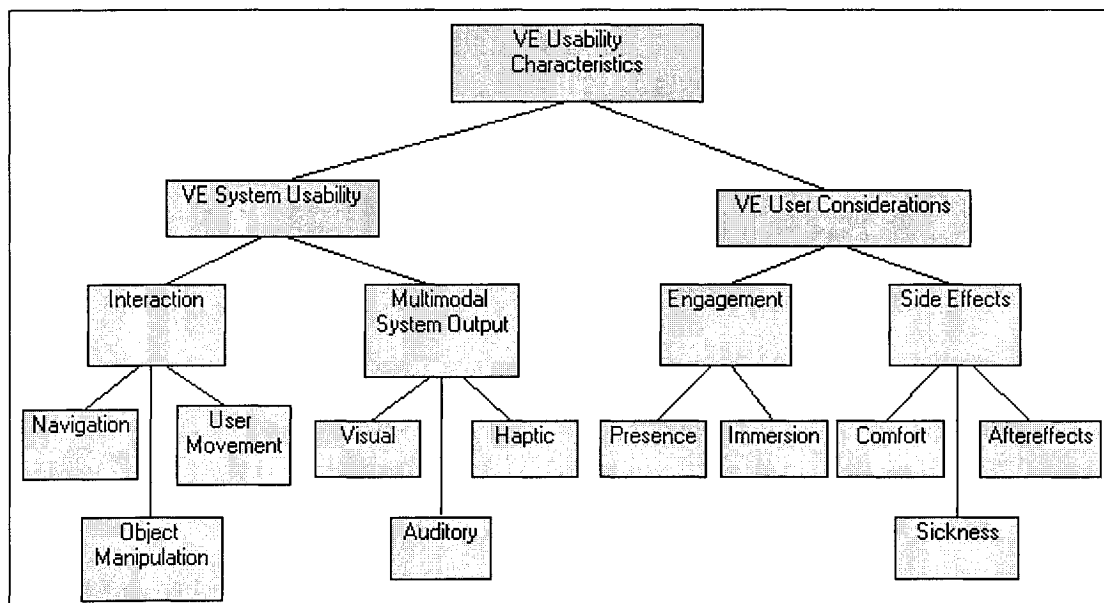

Figure 5.1 Usability criteria of VE assessed by MAUVE [34]

In the following, the usability characteristics of VE system interface and VE user interface [34] are described according to Figure 5.1.

**Interaction** tasks are performed by the navigating user in VE. This is classified as navigation, wayfinding or user movement, and object manipulation.

**Navigation** is a very fundamental operation users perform in large 3D environment. It generally refers moving from one location to another in VE.

**Wayfinding or user movement** refers to locating and orienting oneself in an environment.

**Object manipulation** involves targeting objects within an environment to reposition, rotate, or reorient.

**Multimodal system output** is an important criterion for any VE in order to provide users with multiple forms of inputs and outputs. This may include visual, haptic, and auditory outputs.

**Visual output** provides VE users with visual cues that have significant effect on user task performance and learning.

**Auditory output** is used to augment the VE. In some situations, aural feedback is used alongside visual output that facilitates users' movement in VE.

**Haptic output** usually provides force or tactile feedback in order to have the sense of touch and feel while in the VE.

**Engagement** refers to the sense of presence in the VE. The level of engagement may be in the form of presence and immersion.

**Presence** usually means user's psychological perception of being in the VE.

**Immersion** is the system driven involvement factor that may be considered as the extent of sensory information and stimulating factors provided by VE system components.

**Side effects** may be associated with the use of VE systems and should be minimized. Side effects can be both positive and negative and include comfort, sickness and aftereffects.

**Comfort** is related to the comfortable use and safety of the VE system. Viewing proper depth cues, good contrast, etc. may increase user comfort level.

**Sickness** generally points to difficulty in focusing, nausea, fullness of the head, blurred vision, dizziness with eyes, fatigue, headache, etc. It is desirable to design a VE system that should minimize these symptoms while using the system.

**Aftereffects** are observed once a user has returned to the physical world after using a VE system. Effects such as head spinning, reduced eye-hand coordination, and visual disturbances may bring discomfort to the user.

From the above, some of the factors are filtered out in order not to test LORNAV against those characteristics as LORNAV lacks in those areas. The Haptic and Auditory characteristics under Multimodal System Output for instance are not tested. Similarly, Presence and Immersion under Engagement (also related to haptic-based devices like HMD, data gloves etc.) are not tested.

### 5.1.1 Procedures

A total of eight subjects participated in the study. Among them were one female and seven males. Five of the subjects were enrolled in M.Sc. program in Computer Science, two subjects were enrolled in Ph.D. program in Computer Science, and one subject was a second year undergraduate student. Four of the subjects had prior Human Computer Interaction (HCI) knowledge (classified as group A), while four others did not have any such knowledge (classified as group B).

In this study, the user interface was based on the Internet Explorer browser and Cortona VRML plug-in [64] to view the 3D environment. The main screen was split into two frames. The left frames included the control menu items, while the right frame showed the 2D or 3D interface in response to any user actions with the menu items. The test was conducted on a PC with Intel P4 3.60GHz processor and 1GB of RAM. The test used a 17-inch display monitor.

The subjects were given a short demonstration on how to use the system. They were also given some practice time to play with the interface in order to make them familiar. The subjects were then formally asked to use the LORNAV's search interface to search the learning objects based on either keywords, or specific LOM elements. The search results were displayed on the screen in a 3D environment. The subjects were again asked to navigate around the 3D environment and to interact with the system.

After the subjects finished using the VE system, they were introduced to the MAUVE tool that is used to get their feedback about the system they just explored. The subjects were first asked to do a pairwise comparison of the usability factors as listed in Figure 5.1. For example, a subject was asked whether the VE system interface is of equal importance to the VE user interface. If the answer was yes, the VE system interface was assigned 0.5 and the VE user interface was assigned 0.5 as its cardinal ranking. The cardinal ranking was placed along the connecting line between two separate factors. This cardinal ranking influences the calculation of the sum weight of the factor that is classified as the parent factor. For example, if the VE system interface was weighted 74.61% and VE user interface was weighted 39.66%, the overall usability characteristics of the evaluated system (residing as the root factor of VE system interface and VE user interface) would have been 57.14% ( $74.61 \cdot 0.5 + 39.66 \cdot 0.5$ ). The weight of each individual usability factor was calculated by asking the subjects several questions related to that factor.

Figure 5.2 shows a screen-shot of MAUVE where the subjects were provided with some navigation questionnaire. The questionnaire consisted of closed questions with a seven point scale ranging from 1-Not at all to 7-Completely.

**Virtual Environment (VE) Characteristics: Navigation**  
Questions 1 through 18

On a scale from 1-Not at All to 7-Completely, rate how much you agree with the following statements concerning your system's performance. If statement is not applicable, check the N/A box

NA

<input type="checkbox"/>	<input type="text" value="4-Somewhat"/>	1. Easy to move and reposition self in virtual environment
	<input type="text" value="1-Not at all"/>	
	<input type="text" value="2"/>	
	<input type="text" value="3"/>	
<input type="checkbox"/>	<input type="text" value="4-Somewhat"/>	2. Users often feel disoriented in the virtual environment
	<input type="text" value="5"/>	
	<input type="text" value="6"/>	
	<input type="text" value="7-Completely"/>	
<input type="checkbox"/>	<input type="text" value="4-Somewhat"/>	3. Users often do not know where they are in the virtual environment
<input type="checkbox"/>	<input type="text" value="4-Somewhat"/>	4. Effectively provides appropriate type of user navigation support (naive search, primed search, exploration)

Note: Scale demarcation, 1 - Not at all; 4 - Somewhat; 7 - Completely

Figure 5.2 Sample questions on VE navigation in MAUVE [34]

### 5.1.2 Results

After the end of the experiment with one subject, the MAUVE tool provided the overall scores according to a hierarchical structure as shown in Figure 5.3. There are some interesting facts that may be drawn by observing this structure. The overall VE usability characteristics were scored only 57.14% which reflects poor usability (represented with red color) of the VE system.

Some of the usability factors did not contribute any weight to this score partly because LORNAV does not yet support the functionalities related to those factors, or it supports only partial functionalities. However, a careful look at the result reveals that LORNAV scored well in other usability factors. For example, navigation, object manipulation, visual output and comfort issues are scored between 70 to 84.99% (represented with yellow color), and the user movement, sickness issues and aftereffects are scored higher between 85 to 100% (represented as green).

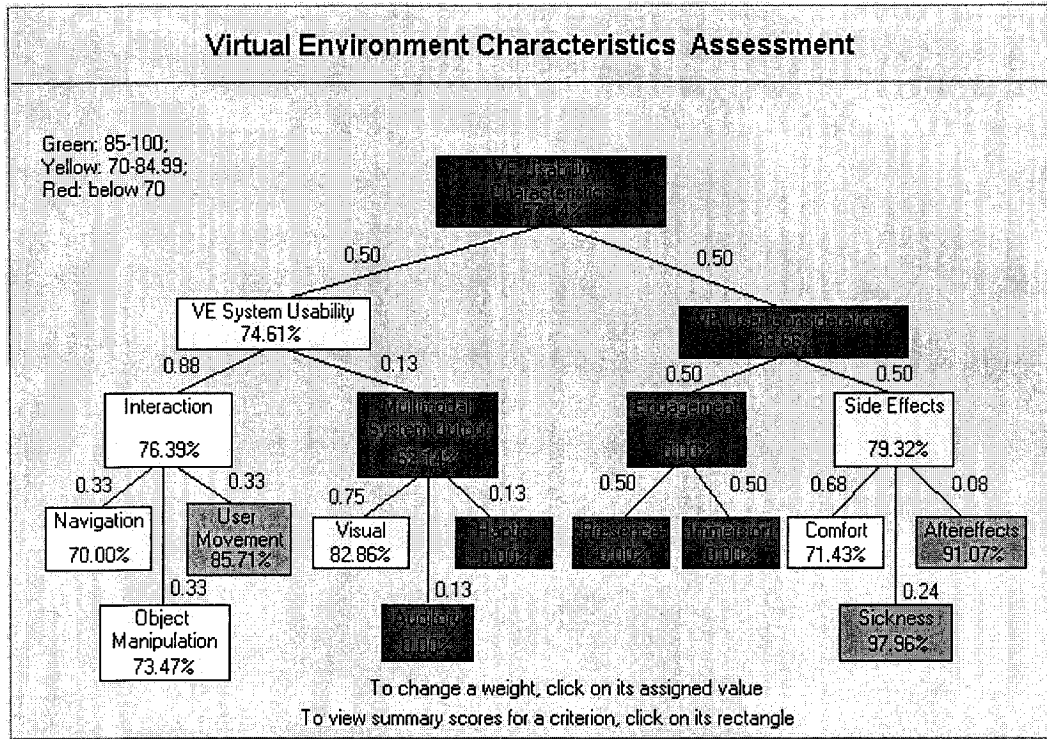

Figure 5.3 Evaluation of overall VE characteristics by a particular subject

Similar evaluation sessions with the remaining subjects were conducted and, for each of them, a result tree like Figure 5.3 was produced. As the usability factors listed at the bottom of the tree are the actual characteristics, the weight of these factors was recorded for each of the subjects in Table 5.1. The avg. of the weights for each usability factor shows encouraging result except those that are marked red.

The overall results are also analyzed for each of the usability factors based on subjects in group A (with HCI knowledge) and group B (without HCI knowledge). The observations are as follows:

Navigation: the mean value of group A and group B is 69.03 and 77.26 respectively. The 90% and 95% confidence interval indicates the higher level means as 69.82 and 69.97 for group A, which shows similarity with the group mean value. On the other hand, the 90% and 95% confidence interval indicates higher level means for group B as

82.36 and 83.34, which is higher than the group mean. This result also shows that the non-HCI group is happier with the system than the HCI group.

Table 5.1 VE multi-criteria evaluation results by the test participants

Subjects		Navigation (%)	Object Manipulation (%)	User movement (%)	Visual (%)	Auditory (%)	Haptic (%)	Presence (%)	Immersion (%)	Comfort (%)	Sickness (%)	Aftereffects (%)
H C I	1	70	73.47	85.71	82.86	0	0	0	0	71.43	97.96	91.07
	2	68.21	70.32	87.85	79.52	0	0	0	0	78	95.54	92.21
	3	69.72	80.12	79.45	85.25	0	0	0	0	80.42	90.58	88.78
	4	68.20	76.87	80.25	86.47	0	0	0	0	70.21	95.98	89.78
N O N - H C I	5	74.40	82.24	92.56	81.23	0	0	0	0	87.36	97.41	94.54
	6	78.43	71.65	82.68	68.66	0	0	0	0	75.58	88.56	92.85
	7	70.87	79.43	83.58	78.89	0	0	0	0	65.88	82.65	85.45
	8	85.34	85.22	90.59	88.96	0	0	0	0	72.39	96.77	95.82
<b>Avg.</b>	<b>73.14</b>	<b>77.41</b>	<b>85.33</b>	<b>81.48</b>	<b>0</b>	<b>0</b>	<b>0</b>	<b>0</b>	<b>75.15</b>	<b>93.18</b>	<b>91.31</b>	
		Interaction		Multimodal system output			Engagement		Side effects			
		VE system usability					VE user considerations					
		VE usability characteristics										

Object manipulation: the mean value of group A and group B is 75.19 and 79.63 respectively. The 90% and 95% confidence interval indicates the higher level means as 78.67 and 79.34 for group A, which is higher than the group mean value. On the other hand, the 90% and 95% confidence interval indicates higher level means for group B as 84.42 and 85.34, which is also higher than the group mean.

User Movement: the mean value of group A and group B is 83.31 and 87.35 respectively. The 90% and 95% confidence interval indicates the higher level means as 86.69 and 87.34 for group A, which is higher than the group mean value. On the other

hand, the 90% and 95% confidence interval indicates higher level means for group B as 91.42 and 92.20, which is also higher than the group mean.

Visual Output: the mean value of group A and group B is 83.52 and 79.43 respectively. The 90% and 95% confidence interval indicates the higher level means as 86.04 and 86.52 for group A, which is close to the group mean value. On the other hand, the 90% and 95% confidence interval indicates higher level means for group B as 86.32 and 87.64, which is higher than the group mean.

Comfort: the mean value of group A and group B is 75.01 and 75.30 respectively. The 90% and 95% confidence interval indicates the higher level means as 79.10 and 79.88 for group A, which is higher than the group mean value. On the other hand, the 90% and 95% confidence interval indicates higher level means for group B as 82.70 and 84.11, which is also higher than the group mean.

Sickness: the mean value of group A and group B is 95.01 and 91.34 respectively. The 90% and 95% confidence interval indicates the higher level means as 97.59 and 98.09 for group A, which is close to the group mean value. On the other hand, the 90% and 95% confidence interval indicates higher level means for group B as 97.10 and 98.26, which is higher than the group mean.

Aftereffects: the mean value of group A and group B is 90.46 and 92.16 respectively. The 90% and 95% confidence interval indicates the higher level means as 91.69 and 91.92 for group A, which is close to the group mean value. On the other hand, the 90% and 95% confidence interval indicates higher level means for group B as 95.98 and 96.71, which is higher than the group mean.

In this analysis of result we ignored four factors (e.g. auditory output, haptic output, presence and immersion) as the supporting functionalities related to those factors are not incorporated in LORNAV.

One of the difficulties encountered during the use of the MAUVE diagnostic tool is its unprecedented list of criteria under each of the usability factors that takes longer times to perform the evaluation. As MAUVE stands as a general evaluation tool for any VE, some questions are ignored that are not applicable to the LORNAV's 3D environment. Our aim in future is to provide the lacking functionalities in LORNAV thereby making it a stable and usable visualization tool for navigating the distributed LORs.

## **5.2 Usability Inspections**

Usability inspections may be performed using established methods in HCI. Examples of such methods include cognitive walk-through and heuristic evaluation.

The cognitive walk-through method requires an expert to walk through a specific task in a prototype system to find potential problems at each step [26]. The aim is to focus on the ease of learning the new interface. This is a more explicitly detailed procedure to simulate a user's problem-solving process at each step through the dialogue and other means.

The heuristic evaluation is a usability engineering method that is used to quickly and easily performing an evaluation of a user interface design in order to find usability problems [25]. This is the most popular usability inspection method. The method suggests having a small set of evaluators to examine the interface and assess its compliance with recognized usability principles. An attempt has been made to perform a heuristic evaluation of LORNAV with an existing diagnostic tool, MAUVE [34].

MAUVE uses the general heuristics as proposed by Nielsen [24] with necessary modification to include the VE specific multimodal interaction. The heuristics that are considered in MAUVE are 1) Simple and natural presentation 2) Speak user's language 3) Memory load 4) Consistency 5) Feedback 6) Clear exits 7) Shortcuts 8) Error handling 9) Help and 10) User demographics.

### 5.2.1 Procedure

Similar to user studies, the heuristic evaluation of LORNAV was conducted using MAUVE [34]. Unlike user studies, three subjects were used to do the evaluation. This is because the heuristic evaluations are usually performed with fewer participants who have previous usability expertise. For each of the heuristics the subjects were asked several questions with a seven point scale ranging from 1-Not at all to 7-Completely. Example of some questions includes:

- Can effectively perform tasks in flexible manner
- User can effectively alter point of view (viewing scenes and objects from various angles)
- Provides unique, powerful and insightful presentation of application specific data
- Input device designs makes effective use of affordances and constraints
- Effectively uses progressive disclosure for information rich interfaces and so on.

### 5.2.2 Results

The responses from the test participants were tabulated to determine a score for each heuristic that indicates how well the system performs in each of the 10 categories. Figure 5.4 shows the result obtained by heuristic evaluation from the first participant. The result shows that the heuristic evaluation of LORNAV is somehow favorable (between 70 to 84.99%, indicated with yellow color) except in feedback and error

handling (indicated with red color). Similarly, the other two subjects also performed the same evaluation. Table 5.2 summarizes the overall heuristic evaluation result.

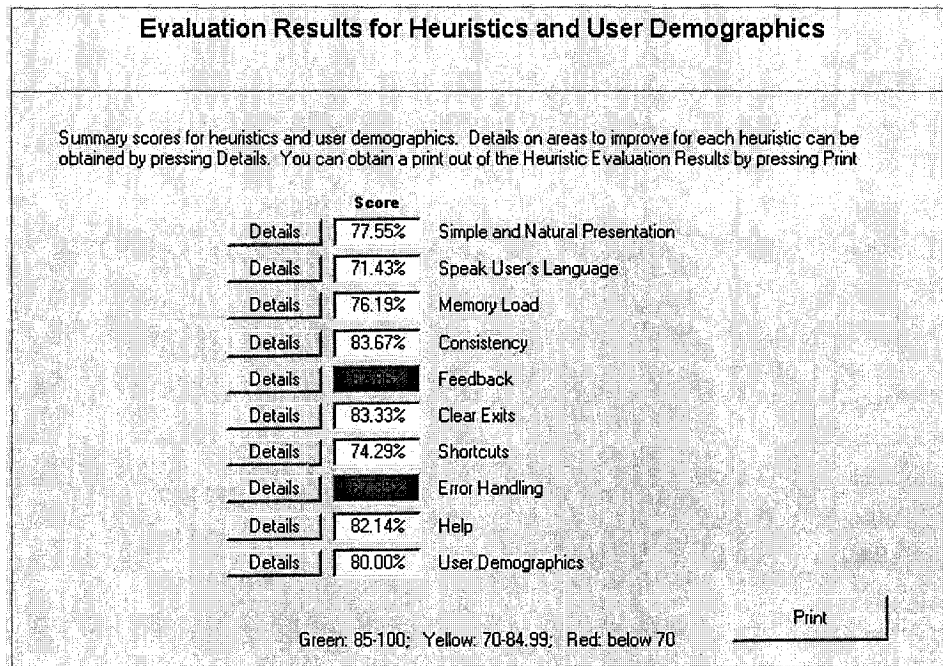

Figure 5.4 Results of the heuristic evaluation by a particular subject

According to the evaluation result shown in Table 5.2, LORNAV scored poor in three heuristics including Feedback, Shortcuts and User demographics. Development is underway to for improved functionality that would address these factors.

Table 5.2 Heuristic evaluation results by the test participants

Subjects	Simple and natural presentation (%)	Speak user's language (%)	Memory load (%)	Consistency (%)	Feedback (%)	Clear exits (%)	Shortcuts (%)	Error handling (%)	Help (%)	User demographics (%)
1	77.55	71.43	76.19	83.67	67.86	83.33	74.29	67.35	82.14	80.00
2	72.84	73.35	81.69	85.23	70.52	90.74	65.86	78.06	76.13	62.16
3	68.32	80.68	65.47	87.14	68.59	85.35	67.34	83.29	69.32	60.72
<b>Avg.</b>	<b>72.90</b>	<b>77.41</b>	<b>75.15</b>	<b>85.35</b>	<b>68.99</b>	<b>86.47</b>	<b>69.16</b>	<b>76.23</b>	<b>75.86</b>	<b>67.62</b>

### **5.3 Summary**

This chapter presented the evaluation procedures for evaluating LORNAV. The evaluation is done using an existing diagnostic tool, MAUVE, which is designed to specifically evaluate VE usability. The evaluation results pointed out the strength and weaknesses of the LORNAV tool. This result may be taken into consideration for further development of the prototype.

## Chapter 6

### Sample Application

The LORNAV tool has been integrated in an e-learning application. The following describes the integration process of LORNAV in that application:

#### **6.1 LORNAV in E-Learning Application**

The LORNAV tool has been integrated in a novel collaborative e-learning system called "**UbiLearn**", which was presented at the CeBIT 2005 exhibition at Germany [57].

The UbiLearn system uses Sharable Content Object Reference Model (SCORM) [68] as the standard to define and manage the learning contents. SCORM is a web-oriented data model for content aggregation that focuses on the structure and run-time environment for learning objects aiming to reuse them between different Learning Management Systems, or course engines.

On the other hand, LOM is concerned with the learning object metadata and is also used by SCORM as one of its component specifications. Figure 6.1 shows the relationship and shared space between SCORM and LOM.

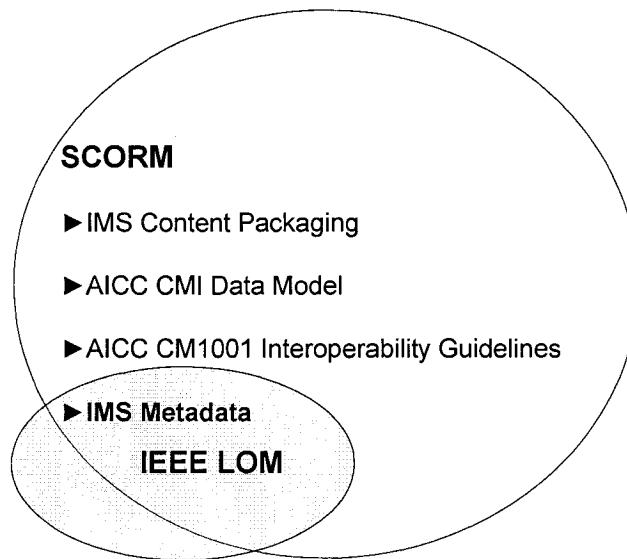

Figure 6.1 Shared metadata space between SCORM and LOM

As LORNAV visualizes LOs by extracting LOM records, this can be easily integrated with the SCORM data model as well. Although unlike LOM, SCORM enforces some mandatory fields while describing the learning content, the process is taken care of by the e-learning system itself and does not affect the LORNAV's visualization procedure.

A decision was made to use the same visualization metaphor that is present in LORNAV in order to visualize the SCO's (the content part in SCORM). Like LOM, SCORM has an XML binding for describing the sharable content in syntactic format. The LORNAV's LOM-XML parser has been used to parse the attributes that are needed for 3D visualization purposes. Also the personalization process was adopted in the new data without any change. Finally, the integration of LORNAV in the UbiLearn system was done as an add-on feature using portal based approach. This is shown in Figure 6.2.

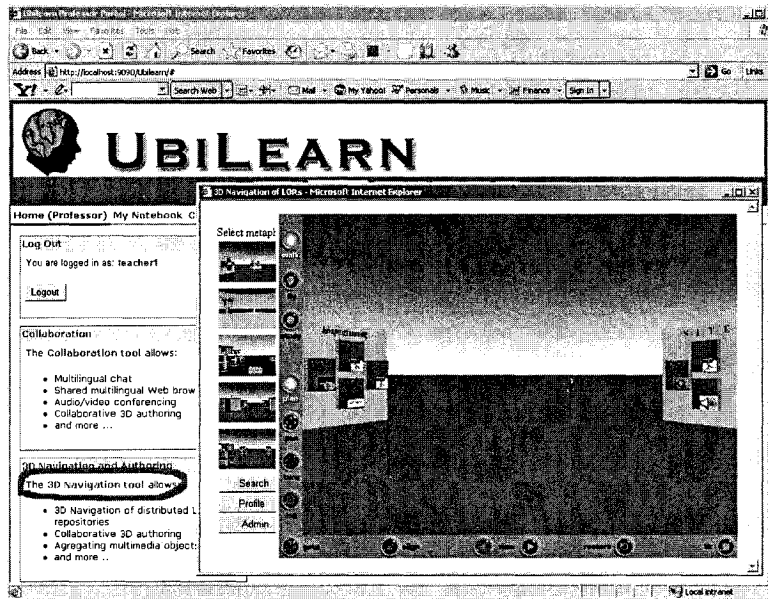

Figure 6.2 LORNAV in UbiLearn environment

Figure 6.3 is another screen shot of the intergraded environment that uses different metaphor. In the figure, a learner has chosen a learning object of type movie and plays it from within the 3D environment.

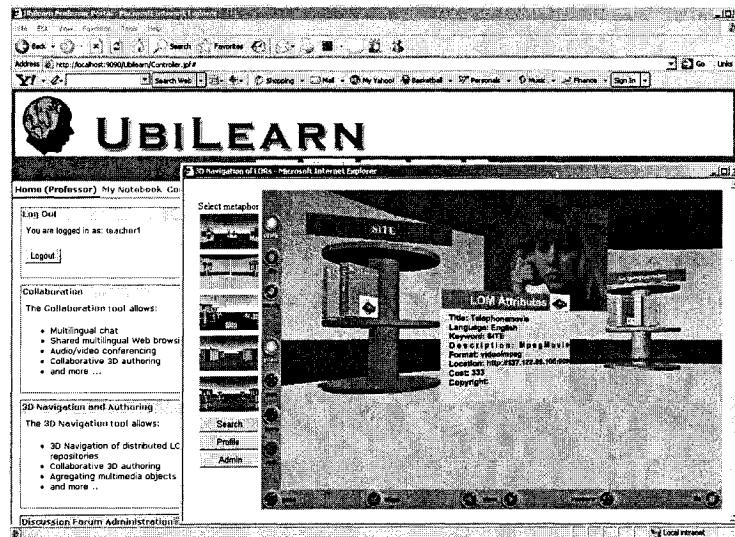

Figure 6.3 Playing a movie in LORNAV/ UbiLearn integrated environment

## 6.2 Extension of LORNAV

The LORNAV tool may be extended to use the metadata model that follows a different standard than LOM, such as DC [67] or ARIADNE [70]. Existing research can be leveraged to do a mapping among these standards. The mapping would eventually provide the data elements LORNAV uses for the visualization of LOs. For example, research in [29] provides a web-based mapping tool that may provide valuable insight to the adoption of a different standard in LORNAV. Table 6.1 shows a mapping table among several metadata standard.

Table 6.1 DC-LOM-ARIADNE semantic mapping [29]

Dublin Core	IEEE LOM	ARIADNE
Identifier	General.Identifier	General.Identifier
Title	General.Title	General.Title
Language	General.language	General.language
Description	General.Description	General.Description
Subject	General.Keyword	Semantics.Discipline&Subdiscipline&MainConcept&MainConceptSynonyms&OtherConcepts
Coverage	General.Coverage	Null
Type	Educational.LearningResourceType	Pedagogical.DocumentType&Pedagogical.documentFormat
Date	LifeCycle.Contribute.Date when LifeCycle.Contribute.role='Publisher'	General.PublicationDate
Creator	LifeCycle.Contribute.Entity when LifeCycle.Contribute.role='Author'	General.Authors
Contributor	LifeCycle.Contribute.Entity with LifeCycle.Contribute.role	General.Authors
Publisher	LifeCycle.Contribute.Entity when LifeCycle.Contribute.role='Publisher'	General.Institution
Format	Technical.Format	Technical.FileMediaTypes
Rights	Rights.Description	Conditions.AccessRights & Restrictions
Relation	Relation.Resource.Description	NULL
Source	Relation.Resource when Relation.Kind='IsBasedOn'	General.Comments_source

## Chapter 7

### Conclusion and Future Work

#### 7.1 Conclusion

This thesis presented the LORNAV tool designed as a general architecture for web-based 3D visualization and navigation of learning objects distributed over multiple repositories. The tool has used the LOM [61] data model as a standard to identify the learning objects. The use of LOM standard makes LORNAV more versatile while incorporating other standards such as SCORM [68], DC [67], and Ariadne [70].

The role of 3D information visualization techniques have been investigated in the development of dynamic virtual environment based on personalized learner's profile. The personalization of a virtual environment offers several benefits, including presenting learners with learning objects of interest and overcoming information overflow by limiting the matching query results. While doing so, several visual

metaphors have been used to help learners to visualize the same search results in many distinct ways to better understand the information.

The tool also accommodated the web service based interface in addition to JDBC over http connectivity to access data from distributed repositories. The data access functionality has been made generic enough to be able to add or update any identical repositories using the LORNAV administration control panel.

Our experience with LORNAV has been encouraging. User evaluation has been positive. Many learners have shown interest while navigating in the 3D environment in order to visualize and search learning contents. We believe that the enriched spatial model may play a significant role in attracting learners to visit, to interact and to adapt LORNAV as a tool of choice to search and visualize learning objects

## **7.2 Future Work**

In this thesis, keyword-based or element-level search algorithms have been applied to retrieve learning objects from the repositories. This approach only returns those results that contain the keyword or element value within certain fields in the metadata records and does not actually reflect the actual closeness of the objects among each other. The aim is to address this issue in our future work by investigating several possible alternatives. One such alternative will be to use Semantic Web [56] to search and classify the learning objects. Preliminary investigations have been performed with the semantic web tools, technologies and applications in [30, 27]. However, we recognize more research is needed in this direction.

We also forecast the use of enhanced user control with the effect of haptic and auditory feedback while navigating the 3D environment. The new input technologies such as eye

gaze, HMD, etc. will be exploited and tested in our virtual environment to provide the user a feelings of actually being in the environment.

Finally, new and intuitive visual metaphors will be investigated to present the learning objects in the virtual environment. Although in LORNAV we have several of such metaphors, the research in finding appropriate metaphor is ever ending.

## Bibliography

- [1] R.M. Rohrer and E. Swing, "Web-Based Information Visualization," *IEEE Computer Graphics and Applications*, vol. 17, no. 4, July/Aug. 1997, pp. 52-59.
- [2] N. Gershon, S.G. Eick, and S. Card, "Information Visualization," *Interactions*, vol. 5, no. 2, Mar./Apr. 1998, pp. 9-15.
- [3] S.G. Eick, "Information Visualization at 10," *IEEE Computer Graphics and Applications*, vol. 25, no. 1, Jan./Feb. 2005, pp. 12-14.
- [4] C.R.D. Santos et al., "Metaphor-Aware 3D Navigation," *Proc. IEEE Symp. Information Visualization*, Oct. 2000, pp. 155-165.
- [5] R.S. Owor, "A Data Model and Architecture for Hypermedia Database Visualization," *Proc. 7th Int'l Conf. 3D Web Technology (Web3D'02)*, Feb. 2002, pp. 121-126.
- [6] E. Duval and W. Hodgins, "A LOM Research Agenda," *Proc. 12th Int'l Conf. World Wide Web (WWW2003)*, May 2003.
- [7] P.R. Polsani, "Use and Abuse of Reusable Learning Objects," *Journal of Digital Information*, vol. 3, no. 4, Feb. 2003.
- [8] K. Ma, "Visualization - A Quickly Emerging Field," *Computer Graphics*, vol. 38, no. 1, Feb. 2004, pp. 4-7.
- [9] F. Neven, E. Duval, "Reusable Learning Objects: a Survey of LOM-Based Repositories," *Proc. 10th ACM Int'l Conf. Multimedia*, Dec. 2002, pp. 291-294.
- [10] A. Celentano, M. Nodari, and F. Pittarello, "Adaptive Interaction in 3D Virtual Worlds," *Proc. 9th Int'l Conf. 3D Web Technology (Web3D'04)*, Apr. 2004, pp. 41-50.
- [11] W. Cellary, W. Wiza, and K. Walczak, "Visualizing Web Search Results in 3D," *Computer*, vol. 37, no. 5, May 2004, pp. 87-89.

- [12] W. Wiza, K. Walczak, and W. Cellary, "Periscope - A System for Adaptive 3D Visualization of Search Results," *Proc. 9th Int'l Conf. 3D Web Technology (Web3D'04)*, Apr. 2004, pp. 29-40.
- [13] T. Guinan, G.M.P O'Hare, and N. Doikov, "ENTER: The Personalisation and Contextualisation of 3-Dimensional Worlds," *Proc. 8th Euromicro Workshop on Parallel and Distributed Processing*, Jan. 2000, pp. 142-148.
- [14] B.M. Dennis and C.G. Healey, "Assisted Navigation for Large Information Spaces," *Proc. IEEE Conf. Visualization (VIS'02)*, Oct. 2002, pp. 419-426.
- [15] P. Mazzoleni et al., "ViRdB: Integrating Virtual Reality and Multimedia Databases for Customized Visualization of Cultural Heritage," *Proc. ACM SIGGRAPH Conf. Sketches and Applications*, Jul. 2003, pp. 1-1.
- [16] P. Mazzoleni et al., "CiVeDi: A Customized Virtual Environment for Database Interaction," *SIGMOD Record*, vol. 33, no. 3, Sept. 2004, pp. 15-20.
- [17] S. Benford et al., "VR-VIBE: A Virtual Environment for Co-operative Information Retrieval," *Proc. Eurographics'95*, Aug. 1995, The Netherlands, pp. 349-360.
- [18] K.A. Oslen et al., "Visualization of Document Collection: The VIBE System," *Information Processing Management*, vol. 29, 1993, pp. 69-81.
- [19] D.R. Nadeau, "Building Virtual Worlds with VRML," *IEEE Computer Graphics and Applications*, vol. 19, no. 2, Mar./Apr. 1999, pp. 18-29.
- [20] B. Shneiderman, "Why Not Make Interfaces Better than 3D Reality?" *IEEE Computer Graphics and Applications*, vol. 23, no. 6, Nov./Dec. 2003, pp. 12-15.
- [21] E. Duval et al., "The ARIADNE Knowledge Pool System," *Communications of the ACM*, vol. 44, no. 5, May 2001, pp. 72-78.
- [22] M.A. Hossain et al., "Architecture for 3D Navigation and Authoring of Distributed Learning Object Repositories," *Proc. 3rd IEEE Int'l Workshop on Haptic, Audio and Visual Environments and their Applications (HAVE 2004)*, Oct. 2004, pp.117-122.
- [23] M.A. Rahman, M.A. Hossain, and A.El Saddik, "LORNAV: A Demo of a Virtual Reality Tool for Navigation and Authoring of Learning Object Repositories," *Proc. 8th IEEE Int'l Symp. Distributed Simulation and Real-Time Applications (DS-RT 2004)*, Oct. 2004, pp. 240-243.

- [24] J. Nielsen, *Usability Engineering*, Boston, MA: Academic Press, 1993.
- [25] J. Nielsen, "Heuristic evaluation". In J. Nielsen, and R.L. Mack (Eds.), *Usability Inspection Methods*, John Wiley & Sons, New York, 1994.
- [26] R.L. Mack and J. Nielsen, "Usability Inspection Methods: Executive Summary". In R.M. Baecker et al. (eds.), *Readings in Human-Computer Interaction: Toward the Year 2000*, second ed., pp. 170-181, San Francisco: Morgan Kaufmann, 1995.
- [27] M.A. Hossain, A. El Saddik and P. Lévy, "Towards a Multi-domain Semantic Web Application," *Proc. Canadian Conf. Electrical and Computer Engineering (CCECE04)*, Niagara, Ontario, Canada, May 2004.
- [28] S. Bryson, "Real-Time Exploratory Scientific Visualization and Virtual Reality," in *Scientific Visualization*, 1994, Advances and Challenges, L. Rosenblum et al. (Eds.), Academic Press.
- [29] Y. Zheng and A. El Saddik. "Study of Metadata for Advanced Multimedia Learning Objects," *Proc. Canadian Conf. Electrical and Computer Engineering (CCECE 2003)*, Montreal, Quebec, Canada, May 2003.
- [30] M.A. Hossain, A. El Saddik "Creating Knowledge and Semantic Web Applications on the Web," *Proc. 2nd Intl. Symposium on Innovation in Information & Communication Technology (ISIICT)*, Amman, Jordan, Apr. 2004.
- [31] G.G. Robertson, S. Card, and W. York, "The WebBook and the Web Forager: An Information Workspace for the World Wide Web," *Proc. SIGCHI 96*, ACM Press, 1996, pp. 11-17.
- [32] L. Chittaro and R. Ranon, "Dynamic Generation of Personalized VRML Content: a General Approach and its Application to 3D E-Commerce," *Proc. 7th Int'l Conf. 3D Web Technology (Web3D'02)*, Feb. 2002, pp. 145-154.
- [33] K. Walczak and W. Cellary, "Building Database Applications of Virtual Reality with X-VRML," *Proc. 7th Int'l Conf. 3D Web Technology (Web3D'02)*, Feb. 2002, pp. 111-120.
- [34] K.M. Stanney et al., "Usability engineering of virtual environments (VEs): identifying multiple criteria that drive effective VE system design," *International Journal of Human-Computer Studies*, vol. 58, no. 4, Apr. 2003, pp. 447-481.

- [35] J. Klerkx, E. Duval, and M. Meire, "Using Information Visualization for Accessing Learning Object Repositories," *Proc. 8th Int'l Conf. Information Visualization (IV'04)*, July 2004, pp. 465-470.
- [36] L. Chittaro, R. Ranon, and L. Ieronutti, "Guiding Visitors of Web3D Worlds through Automatically Generated Tours," *Proc. 8th Int'l Conf. 3D Web Technology (Web3D'03)*, Mar. 2003, pp. 27-38.
- [37] R. Wojciechowski et al., "Building Virtual and Augmented Reality Museum Exhibitions," *Proc. 9th Int'l Conf. 3D Web Technology (Web3D'04)*, Apr. 2004, pp. 135-144.
- [38] S.K. Card, J.D. Mackinlay, and B. Shneiderman, *Readings in Information Visualization: Using Vision to Think*, Morgan Kaufmann Publishers, Jan. 1999.
- [39] M. Hatala et al., "The EduSource Communication Language: Implementing Open Network for Learning Repositories and Services," *Proc. 19th Ann. ACM Symp. Applied Computing (SAC'04)*, Mar. 2004, pp. 957-962.
- [40] A. Massari and L. Saladini, "Virgilio: a VR-based System for Database Visualization," *Proc. Advanced Visual Interfaces*, May 1996, pp. 263-265.
- [41] A. Kobsa, J. Koenemann, and W. Pohl, "Personalized Hypermedia Presentation Techniques for Improving Online Customer Relationships," *The Knowledge Engineering Review*, vol. 16, no. 2, 2001, pp. 111-155.
- [42] D.A. Bowman et al., "An Introduction to 3-D User Interface Design," *Presence*, vol. 10, no. 1, Feb. 2001, pp. 96-108.
- [43] J.J. Van Wijk, F.V. Ham, and H.V.D Wetering, "Rendering Hierarchical Data," *Communications of the ACM*, vol. 46, no. 9, Sept. 2003, pp. 257-263.
- [44] C. Manetta and R. Blade, "Glossary of Virtual Reality Terminology," *International Journal of Virtual Reality*, vol. 1, no. 2, 1995.
- [45] J. Vince, *Introduction to Virtual Reality*, Springer-Verlag, Mar. 2004.
- [46] S.G. Eick, "Visual Discovery and Analysis," *IEEE Transactions on Visualization and Computer Graphics*, vol. 6, no. 1, Jan./Mar. 2000, pp. 44-58.
- [47] A. Cockburn and B. McKenzie, "Evaluating the Effectiveness of Spatial Memory in 2D and 3D Physical and Virtual Environments," *Proc. ACM Conf. Human Factors in Computing Systems (CHI 2002)*, Apr. 2002, pp. 203-210.

- [48] G.G. Robertson, J.D. Mackinlay, and S.K. Card, "Cone Trees: Animated 3D Visualizations of Hierarchical Information," *Proc. ACM Conf. Human Factors in Computing Systems* (CHI 1991), Apr. 1991, pp. 189-194.
- [49] M. Tory and T. Mo"ller, "Human Factors in Visualization Research," *IEEE Transactions on Visualization and Computer Graphics*, vol. 10, no. 1, Jan./Feb. 2004, pp. 72-84.
- [50] R.S. Kalawsky, "VRUSE - a Computerized Diagnostic Tool: for Usability Evaluation of Virtual/Synthetic Environments Systems," *Applied Ergonomics*, vol. 30, 1999, pp. 11-25.
- [51] A. Spoerri, "InfoCrustal: A Visual Tool for Information Retrieval," *Proc. IEEE Visualization 93*, IEEE Computer Soc. Press, California, 1993, pp. 150-157.
- [52] C. Chen, "Individual Differences in Visual Navigation," *Information Visualization and Virtual Environments*, Springer-Verlag, 1999, pp. 139-174.
- [53] E. Gamma et al., *Design Patterns*, Addison-Wesley Professional, Jan. 1995.
- [54] A.V. Dam, S. Becker and R.M. Simpson, "Next-Generation Educational Software: Why We Need It and a Research Agenda for Getting It," *EDUCAUSE Review*, vol. 40, no. 2, Mar./Apr. 2005, pp. 26-43; <http://www.educause.edu/er/erm05/erm0521.asp?bhcp=1>. Last visited: Jan. 12, 2005.
- [55] D.A. Wiley, "Connecting learning objects to instructional design theory: A definition, a metaphor, and a taxonomy". In D.A. Wiley (ed.), *The Instructional Use of Learning Objects*, Online version, Nov. 2000, pp. 1-35; <http://www.reusability.org/read/chapters/wiley.doc>. Last visited: Mar. 3, 2005.
- [56] T. Berners-Lee, J. Hendler, and O. Lassila, "The Semantic Web," *Scientific American*, vol. 284, May 2001, pp. 34-43; <http://www.sciam.com/article.cfm?articleID=00048144-10D2-1C70-84A9809EC588EF21>. Last visited: Jun. 21, 2004.
- [57] CeBIT, Canadian Exhibitors at Future Parc 2005; [http://www.canada-cebit.com/freetext.asp?ftmod=freetext\\_000000008](http://www.canada-cebit.com/freetext.asp?ftmod=freetext_000000008). Last visited: Apr. 23, 2005.
- [58] VRML Specification; <http://tecfa.unige.ch/guides/vrml/vrml97/spec/>. Last visited: Feb. 11, 2005.

- [59] C. Marrin, "Proposal for a VRML 2.0 Informative Annex, External Authoring Interface Reference," Nov. 1997; <http://tecfa.unige.ch/guides/vrml/vrml97/ExternalInterface.html>. Last visited: Feb. 11, 2005.
- [60] ECL: eduSource Communication Layer; <http://lore.iat.sfu.ca/ecl/>. Last visited: May 3, 2005.
- [61] IEEE Learning Object Metadata, final draft standard, Jul. 15, 2002 (IEEE 1484.12.1); [http://ltsc.ieee.org/wg12/files/LOM\\_1484\\_12\\_1\\_v1\\_Final\\_Draft.pdf](http://ltsc.ieee.org/wg12/files/LOM_1484_12_1_v1_Final_Draft.pdf). Last visited: Apr. 3, 2005.
- [62] J. Sonstein, "VRML Goes Dynamic," <http://www.vrmlsite.com/oct96/spotlight/proto/proto.html>. Last visited: Jan. 7, 2005.
- [63] X3D Documentation; <http://www.web3d.org/x3d/>. Last visited: Dec. 30, 2004.
- [64] Cortona VRML Client; <http://www.parallelgraphics.com/products/cortona/>. Last visited: Dec. 25, 2004.
- [65] BS Contact VRML/X3D; <http://www.bitmanagement.de/>. Last visited: Nov. 24, 2004.
- [66] blaxxun Contact 5; <http://www.blaxxun.com/en/products/contact/index.html>. Last visited: Dec. 14, 2004.
- [67] Dublin Core Metadata Initiative; <http://dublincore.org/>. Last visited: Mar. 30, 2005.
- [68] SCORM Overview; <http://www.adlnet.org/index.cfm?fuseaction=scormabt>. Last visited: Feb. 26, 2005.
- [69] CanCore; <http://www.cancore.ca/indexen.html>. Last visited: June 10, 2005.
- [70] ARIADNE; <http://www.ariadne-eu.org>. Last visited: Jan. 10, 2005.
- [71] LORNET; <http://www.lornet.org/eng/>. Last visited: June 12, 2005.
- [72] eduSourceCanada, Canadian Network of Learning Object Repositories; [http://www.edusource.ca/english/objects\\_eng.html](http://www.edusource.ca/english/objects_eng.html). Last visited: May 15, 2005.
- [73] EdNA; <http://www.edna.edu.au>. Last visited: Dec. 28, 2004.

- [74] MPEG-7 Overview; <http://www.chiariglione.org/mpeg/standards/mpeg-7/mpeg-7.htm>. Last visited: June 9, 2005.
- [75] D. Cowie, "Use JSP to create your own VRML world," Aug. 2002; <http://builder.com.com/5100-6371-1050067.html>. Last visited: Nov. 22, 2004.
- [76] G. Geisler, "Making Information More Accessible: A Survey of Information Visualization Applications and Techniques," Jan. 1998; <http://www.ils.unc.edu/~geisg/info/infovis/paper.html>. Last visited: Oct. 8, 2004.
- [77] B. Stearns et al., "Designing Enterprise Applications with the J2EE Platform," Second Edition; [http://java.sun.com/blueprints/guidelines/designing\\_enterprise\\_applications\\_2e/DEA2eTOC.html](http://java.sun.com/blueprints/guidelines/designing_enterprise_applications_2e/DEA2eTOC.html). Last visited: Jan. 17, 2005.