



uOttawa

L'Université canadienne  
Canada's university

FACULTÉ DES ÉTUDES SUPÉRIEURES  
ET POSTDOCTORALES



FACULTY OF GRADUATE AND  
POSTDOCTORAL STUDIES

Tianmin Fan

AUTEUR DE LA THÈSE / AUTHOR OF THESIS

M.A.Sc. (Electrical Engineering)

GRADE / DEGREE

School of Information Technology and Engineering

FACULTÉ, ÉCOLE, DÉPARTEMENT / FACULTY, SCHOOL, DEPARTMENT

A Novel Dynamic Bandwidth Allocation Algorithm with QoS Support for EPON Access Networks

TITRE DE LA THÈSE / TITLE OF THESIS

H. Mouftah

DIRECTEUR (DIRECTRICE) DE LA THÈSE / THESIS SUPERVISOR

CO-DIRECTEUR (CO-DIRECTRICE) DE LA THÈSE / THESIS CO-SUPERVISOR

EXAMINATEURS (EXAMINATRICES) DE LA THÈSE / THESIS EXAMINERS

J. Zhao

C-H. Lung

Gary W. Slater

LE DOYEN DE LA FACULTÉ DES ÉTUDES SUPÉRIEURES ET POSTDOCTORALES /  
DEAN OF THE FACULTY OF GRADUATE AND POSTDOCTORAL STUDIES

**A NOVEL DYNAMIC BANDWIDTH  
ALLOCATION ALGORITHM WITH QoS  
SUPPORT FOR EPON ACCESS  
NETWORKS**

By

**Tianmin Fan**

A thesis submitted to the Faculty of Graduate and Postdoctoral Studies

in partial fulfillment of the requirements for the degree of

Master of Applied Science

In

Electrical and Computer Engineering

**Ottawa-Carleton Institute for Electrical and Computer Engineering**

**School of Information Technology and Engineering**

**University of Ottawa**

**Ottawa, Ontario, Canada**

**© Tianmin Fan, Ottawa, Canada, 2006**



Library and  
Archives Canada

Bibliothèque et  
Archives Canada

Published Heritage  
Branch

Direction du  
Patrimoine de l'édition

395 Wellington Street  
Ottawa ON K1A 0N4  
Canada

395, rue Wellington  
Ottawa ON K1A 0N4  
Canada

*Your file* *Votre référence*

*ISBN: 0-494-14903-5*

*Our file* *Notre référence*

*ISBN: 0-494-14903-5*

#### NOTICE:

The author has granted a non-exclusive license allowing Library and Archives Canada to reproduce, publish, archive, preserve, conserve, communicate to the public by telecommunication or on the Internet, loan, distribute and sell theses worldwide, for commercial or non-commercial purposes, in microform, paper, electronic and/or any other formats.

The author retains copyright ownership and moral rights in this thesis. Neither the thesis nor substantial extracts from it may be printed or otherwise reproduced without the author's permission.

#### AVIS:

L'auteur a accordé une licence non exclusive permettant à la Bibliothèque et Archives Canada de reproduire, publier, archiver, sauvegarder, conserver, transmettre au public par télécommunication ou par l'Internet, prêter, distribuer et vendre des thèses partout dans le monde, à des fins commerciales ou autres, sur support microforme, papier, électronique et/ou autres formats.

L'auteur conserve la propriété du droit d'auteur et des droits moraux qui protègent cette thèse. Ni la thèse ni des extraits substantiels de celle-ci ne doivent être imprimés ou autrement reproduits sans son autorisation.

---

In compliance with the Canadian Privacy Act some supporting forms may have been removed from this thesis.

Conformément à la loi canadienne sur la protection de la vie privée, quelques formulaires secondaires ont été enlevés de cette thèse.

While these forms may be included in the document page count, their removal does not represent any loss of content from the thesis.

Bien que ces formulaires aient inclus dans la pagination, il n'y aura aucun contenu manquant.

  
**Canada**

## ABSTRACT

Ethernet passive optical network (EPON) has been considered as an attractive solution to next-generation broadband access networks due to its low cost and high throughput. However, designing efficient bandwidth allocation algorithms is a critical issue in EPON. In this thesis, various dynamic bandwidth allocation (DBA) algorithms for EPON systems are first reviewed. A novel DBA algorithm, called per-slot DBA (PSDBA), is then presented to efficiently and fairly allocate bandwidth among different users. The PSDBA algorithm is based on the multi-point control protocol (MPCP) and allocates bandwidth on a per-slot basis. It is also combined with non-strict priority scheduling and priority queuing to support differentiated services in the design of an EPON system.

Extensive simulation experiments are performed. Simulation results show that the PSDBA algorithm outperforms a well-known DBA algorithm using a per-frame bandwidth allocation strategy.

## **ACKNOWLEDGEMENTS**

I am deeply grateful to my supervisor, Professor Hussein T. Mouftah, for his knowledgeable academic guidance and encouragement during the course of my studies and research work at the School of Information Technology and Engineering of the University of Ottawa. It was him who gave me the opportunity to explore the fields of computer communication networks. The freedom that Professor Mouftah has given me is my responsibility and is gratefully appreciated.

I would like to thank Dr. Jun Zheng, for his encouragement and guidance during my studies as well as his helpful comments and suggestion in this thesis. I would also like to give my special thanks to Dr. Baoxian Zhang for many insightful conversations during the development of the ideas in this thesis.

I am deeply indebted to my husband and my daughter, especially my daughter who has been affected the most. I would not be able to finish my study without their endless love, support and encouragement. Lastly, I would like to express my deep appreciation to my parents. They gave me a very positive influence on my life and career. No words could express how much I thank them.

# TABLE OF CONTENT

|   |            |
|---|------------|
| <b>ABSTRACT.....</b>                              | <b>I</b>   |
| <b>ACKNOWLEDGEMENTS .....</b>                     | <b>II</b>  |
| <b>TABLE OF CONTENT.....</b>                      | <b>III</b> |
| <b>ACRONYMS .....</b>                             | <b>VI</b>  |
| <b>LIST OF SYMBOLS .....</b>                      | <b>IX</b>  |
| <b>LIST OF FIGURES .....</b>                      | <b>XI</b>  |
| <b>CHAPTER 1 INTRODUCTION.....</b>                | <b>1</b>   |
| 1.1    BACKGROUND.....                            | 1          |
| 1.2    MOTIVATIONS.....                           | 3          |
| 1.3    OBJECTIVES .....                           | 4          |
| 1.4    THESIS CONTRIBUTIONS .....                 | 4          |
| 1.5    THESIS ORGANIZATION.....                   | 6          |
| <b>CHAPTER 2 POLLING MECHANISMS AND BANDWIDTH</b> |            |
| <b>ALLOCATION ALGORITHMS IN EPONS .....</b>       | <b>8</b>   |
| 2.1    INTRODUCTION .....                         | 8          |
| 2.2    EPON: TECHNOLOGIES AND ARCHITECTURES.....  | 9          |
| 2.3    KEY ISSUES IN EPON .....                   | 12         |
| 2.4    POLLING MECHANISMS.....                    | 14         |

|         |   |    |
|---------|---|----|
| 2.2.1   | MPCP .....  | 15 |
| 2.2.2   | Related Work on Polling Protocols.....              | 17 |
| 2.2.2.1 | Broadcast Polling .....                             | 18 |
| 2.2.2.2 | Non-Broadcast Polling.....                          | 19 |
| 2.5     | BANDWIDTH ALLOCATION ALGORITHMS .....               | 20 |
| 2.2.1   | Static Bandwidth Allocation Algorithm .....         | 21 |
| 2.2.2   | Dynamic Bandwidth Allocation (DBA) Algorithms ..... | 22 |
| 2.2.2.1 | Statistical Multiplexing Scheme .....               | 22 |
| 2.2.2.2 | DBA with QoS Support .....                          | 25 |
| 2.6     | SUMMARY.....  | 30 |

**CHAPTER 3 A NOVEL PER SLOT BASED DBA ALGORITHM WITH QOS SUPPORT .....31**

|       |   |    |
|-------|---|----|
| 3.1   | MOTIVATIONS.....                            | 31 |
| 3.2   | NETWORK MODEL .....                         | 34 |
| 3.3   | POLLING PROTOCOL DESIGN.....                | 36 |
| 3.4   | ONU QUEUE MANAGEMENT .....                  | 39 |
| 3.4.1 | Priority Queuing.....                       | 39 |
| 3.4.2 | Packet Scheduling.....                      | 40 |
| 3.5   | THE PSDBA ALGORITHM.....                    | 44 |
| 3.6   | BANDWIDTH ALLOCATION WITH QOS SUPPORT ..... | 50 |
| 3.7   | SUMMARY.....                                | 52 |

**CHAPTER 4 PERFORMANCE EVALUATION AND SIMULATION RESULTS 54**

|                                    |                                      |           |
|------------------------------------|--------------------------------------|-----------|
| 4.1                                | INTRODUCTION .....                   | 54        |
| 4.2                                | SIMULATION MODEL.....                | 54        |
| 4.2.1                              | Assumptions.....                     | 54        |
| 4.2.2                              | Metrics .....                        | 55        |
| 4.2.3                              | Simulation Flowcharts .....          | 57        |
| 4.3                                | SIMULATION RESULTS .....             | 62        |
| 4.3.1                              | DBA without QoS Support.....         | 62        |
| 4.3.2                              | DBA with QoS Support .....           | 66        |
| 4.4                                | SUMMARY.....                         | 74        |
| <b>CHAPTER 5 CONCLUSIONS .....</b> |                                      | <b>75</b> |
| 5.1                                | SUMMARY AND CONCLUDING REMARKS ..... | 75        |
| 5.2                                | OPEN ISSUES .....                    | 76        |
| <b>REFERENCES.....</b>             |                                      | <b>78</b> |

## ACRONYMS

|         |  |
|---------|--|
| APON    | ATM Passive Optical Network                            |
| ATM     | Asynchronous Transfer Mode                             |
| BA      | Bandwidth Allocation                                   |
| BGP     | Bandwidth Guaranteed Polling                           |
| BP      | Broadcast Polling                                      |
| BPON    | Broadband Passive Optical Network                      |
| CM      | Cable Modem  |
| CO      | Central Office   |
| CSMA/CD | Carrier Sense Multiple Access with Collision Detection |
| DBA     | Dynamic Bandwidth Allocation                           |
| DSL     | Digital Subscriber Line                                |
| DSLAM   | Digital Subscriber Line Access Multiplexer             |
| EFM     | Ethernet in the First Mile                             |
| EPON    | Ethernet Passive Optical Network                       |
| FBA     | Fixed Bandwidth Allocation                             |
| FSAN    | Full Service Access Network                            |
| FTTB    | Fiber to the Building                                  |
| FTTC    | Fiber to the Curb                                      |
| FTTH    | Fiber to the Home                                      |
| GPON    | Gigabit Passive Optical Network                        |
| GEPON   | Gigabit Ethernet Passive Optical Network               |

|       |   |
|-------|---|
| GPS   | Generalized Processor Sharing   |
| HDTV  | High Definition Television  |
| HFC   | Hybrid Fiber Coax   |
| IFG   | Inter-Frame Gap   |
| IPACT | Interleaved Polling with Adaptive Time  |
| ITU-T | International Telecommunication Union-Telecommunication<br>Standardization Sector |
| LANs  | Local Area Networks   |
| MAC   | Media Access Control  |
| MAN   | Metropolitan Area Network   |
| MPCP  | Multipoint Control Protocol   |
| MTW   | Maximum Transmission Window   |
| OLT   | Optical Line Terminal   |
| ONUs  | Optical Network Units   |
| PON   | Passive Optical Network   |
| QoS   | Quality of Service  |
| RTT   | Round-Trip Time   |
| TDMA  | Time Division Multiplexing Access   |
| ToS   | Type-of-Service   |
| TLBA  | Two-Layer Bandwidth Allocation  |
| SLAs  | Service Level Agreements  |
| WAN   | Wide area Network   |
| WDM   | Wavelength Division Multiplexing  |

VoD

Video on demand

## LIST OF SYMBOLS

|                                    |  |
|------------------------------------|--|
| $N$                                | The number of ONUs   |
| $W_{\max}$                         | The maximum transmission window  |
| $R_u$                              | The data rate of the access link from a user to an ONU   |
| $R_N$                              | The rate of the upstream link from an ONU to the OLT   |
| $S$                                | The largest distance between the OLT and ONUs  |
| $T_g$                              | The guard time between the transmissions of different ONUs   |
| $T_{\text{cycle}}$                 | The granting cycle time that is the time during which all active ONUs can transmit and report to the OLT |
| $w_i$                              | The weight assign to ONU $i$ based on its SLA  |
| $R_i$                              | The total requested bandwidth of ONU $i$   |
| $H_i$                              | The requested bandwidth of high priority traffic of ONU $i$  |
| $M_i$                              | The requested bandwidth of medium priority traffic of ONU $i$  |
| $L_i$                              | The requested bandwidth of low priority traffic of ONU $i$   |
| $B_i^{\min}$                       | The minimum guaranteed bandwidth allocated to ONU $i$ by the OLT   |
| $B_{\text{total}}^{\text{excess}}$ | The total excess bandwidth, which is contributed from those lightly-loaded ONUs                          |
| $B_i^{\text{excess}}$              | The excess bandwidth allocated to ONU $i$  |
| $H_i^{\text{grant}}$               | The bandwidth granted to the high priority traffic for ONU $i$   |
| $M_i^{\text{grant}}$               | The bandwidth granted to the medium priority traffic for ONU $i$   |

$L_i^{grant}$  The bandwidth granted to the low priority traffic for ONU*i*

$B_i^{grant}$  The granted bandwidth for ONU*i*

# LIST OF FIGURES

|   |    |
|---|----|
| FIGURE 2.1 A TYPICAL EPON ARCHITECTURE.....   | 10 |
| FIGURE 2.2 GATE MESSAGE [PESA03].....   | 16 |
| FIGURE 2.3 REPORT MESSAGE [PESA03].....   | 17 |
| FIGURE 2.4 BANDWIDTH ALLOCATION ALGORITHMS CLASSIFICATIONS .....                                      | 21 |
| FIGURE 3.1 DBA WITH IDLE TIME .....   | 32 |
| FIGURE 3.2 ENHANCED DBA WITH LESS IDLE TIME .....   | 33 |
| FIGURE 3.3 A NETWORK MODEL OF AN EPON SYSTEM .....  | 34 |
| FIGURE 3.4 A FLOW OF GATE AND REPORT MESSAGE.....   | 38 |
| FIGURE 3.5 PRIORITY QUEUING .....   | 40 |
| FIGURE 3.6 MPCP GATE MESSAGE FORMAT.....  | 41 |
| FIGURE 3.7 AN EXAMPLE OF ILLUSTRATING PACKET SCHEDULING.....  | 43 |
| FIGURE 3.8 ILLUSTRATION OF PER-SLOT BANDWIDTH ALLOCATION SCHEME. THERE<br>ARE IN TOTAL $N$ ONUS. .... | 50 |
| FIGURE 4.1 FLOWCHART OF GRANTTRANS .....  | 58 |
| FIGURE 4.2 FLOWCHART OF DATATRANS EVENT .....   | 59 |
| FIGURE 4.3 FLOWCHART OF REQUESTARRIVAL .....  | 60 |
| FIGURE 4.4 FLOWCHART OF MAIN FUNCTION .....   | 61 |
| FIGURE 4.5 COMPARISON OF AVERAGE PACKET DELAY (AD) .....  | 63 |
| FIGURE 4.6 COMPARISON OF MAXIMUM PACKET DELAY (MD) .....  | 64 |
| FIGURE 4.7 COMPARISON OF THROUGHPUT.....  | 65 |
| FIGURE 4.8 COMPARISON OF AVERAGE QUEUE LENGTH.....  | 65 |

|  |    |
|--|----|
| FIGURE 4.9(A) COMPARISON OF AVERAGE PACKET DELAY FOR EF TRAFFIC .....  | 67 |
| FIGURE 4.9(B) COMPARISON OF AVERAGE PACKET DELAY FOR AF TRAFFIC .....  | 67 |
| FIGURE 4.9(C) COMPARISON OF AVERAGE PACKET DELAY FOR BE TRAFFIC .....  | 68 |
| FIGURE 4.10(A) COMPARISON OF MAXIMUM PACKET DELAY FOR EF TRAFFIC ..... | 68 |
| FIGURE 4.10(B) COMPARISON OF MAXIMUM PACKET DELAY FOR AF TRAFFIC.....  | 69 |
| FIGURE 4.10(C) COMPARISON OF MAXIMUM PACKET DELAY FOR BE TRAFFIC.....  | 69 |
| FIGURE 4.11 COMPARISON OF THROUGHPUT -INTRA-ONU BY ONUs.....           | 70 |
| FIGURE 4.12(A) COMPARISON OF AVERAGE QUEUE LENGTH FOR EF.....          | 71 |
| FIGURE 4.12(B) COMPARISON OF AVERAGE QUEUE LENGTH FOR AF .....         | 72 |
| FIGURE 4.12(C) COMPARISON OF AVERAGE QUEUE LENGTH FOR BE .....         | 72 |
| FIGURE 4.13 COMPARISON OF THROUGHPUT- INTRA-ONU BY THE OLT .....       | 74 |

# Chapter 1 INTRODUCTION

## 1.1 Background

The huge growth of the Internet traffic and emerging broadband applications has resulted in significantly increased capacity in backbone networks. In the meantime, there has been little progress in access networks, which are commonly referred to as the *first mile* or once called *last mile*. Therefore, the first mile becomes the bottleneck between high-speed local area networks (LANs) and the backbone networks. Nowadays, the most widely deployed broadband access networks deployed by service providers are digital subscriber line (DSL) and cable modem (CM) technologies [KRAM02B]. DSL uses the same twisted telephone line and a DSL modem at the customer premise and a digital subscriber line access multiplexer (DSLAM) at the central office. The typical data speed provided by the DSL is 128kb/s-1.5Mb/s. However, the distance covered by one central office is limited to several miles even though remote DSLAM is deployed [KRAM02B]. Cable companies use hybrid fiber coax (HFC) networks, which can provide only up to 36Mb/s effective data throughput, which is not enough speed during peak hours. Thus, neither DSL nor HFC solutions are able to provide enough capacity for those emerging services, such as IP telephony, high definition television (HDTV), video

on demand (VoD), interactive games and two-way video conference. The next step of access network is to bring fiber to the curb (FTTC), building (FTTB) or the home (FTTH). The fiber optical networks are capable of providing gigabit per second speed and delivering bandwidth-intensive integrated voice, data and video service to customers at distance beyond 20 KM.

A passive optical network (PON) is viewed as a promising solution to the first mile problem [PESA99]. A PON is a point-to-multipoint all optical access network with no active elements in the transmission path from source to destination [KRAM02A]. PON has been categorized into several types: Asynchronous Transfer Mode PON/Broadband PON (APON/BPON), Gigabit PON (GPON), Ethernet PON (EPON), Gigabit Ethernet (GE-PON) [PHIL05]. Two standard organizations, i.e., ITU-T and IEEE, have led discussion of PON specifications. Full service access network (FSAN) group has fully supported ITU-T to finalize recommendations (e.g., ITU-T G.983, G.984, and Q.834 series) as one of standardization advisory group. In ITU-T and FSAN, full service PONs (i.e., BPON (formally named APON) and GPON) have been discussed. On the other hand, in IEEE, Ethernet service PON (EPON) has been discussed in IEEE 802.3 ah as one of extensions of Gigabit-Ethernet.

Recently, EPON has gained more attention both in academia as well as industry. It has been considered as an attractive cost-effective solution for the next generation broadband access networks. EPON is being defined by the IEEE 802.ah Task Force Ethernet in the First Mile (EFM) as one of the Ethernet interface

series. EPON carries data encapsulated in Ethernet frame, which makes easier to carry IP packets and ease interoperability with existing installed Ethernet LANs. Ethernet is not an expensive technology and it is used everywhere and interoperable with other legacy equipment. EPON combines low cost Ethernet equipment and low cost fibre infrastructure. Moreover, given the fact that today's 90% traffic is originated from Ethernet LANs. EPON provides a number of advantages over traditional access networks, such as operating distance, reduced equipment and maintenance cost, and easy upgrade to higher bit rates or addition wavelength [KRAM02B]. It has been widely recognized that EPON is an attractive solution to the "first mile" bottleneck problem in next-generation broadband access networks [ZHEN05A].

## **1.2 Motivations**

In an EPON system, all Optical Network Units (ONUs) have to share the same transmission channel in the upstream direction (i.e., from ONUs to the OLT). To better meet the bandwidth requirements of different users, a desirable solution is that the Optical Line Terminal (OLT) can dynamically allocate bandwidth to each ONU based on its demand instantaneously. Multi-Point Control Protocol (MPCP) is a control protocol for facilitating dynamic bandwidth allocation and arbitrating the transmission of ONUs, and it does not specify any particular bandwidth allocation scheme. Hence, an efficient and fair bandwidth allocation algorithm becomes a critical issue to design an EPON system. A lot of bandwidth allocation algorithms have been proposed to address this problem. However, none of these

algorithms could completely remove the inter-frame idle time of the upstream channel, which will be explained in Section 3.1 in detail. For this purpose, a new dynamic bandwidth allocation scheme is needed to achieve higher network utilization and thus improve network performance.

### **1.3 Objectives**

The primary objective of this thesis is to develop an efficient dynamic bandwidth allocation (DBA) algorithm for upstream traffic transmission in EPON access networks based on the thorough examination of various existing dynamic bandwidth allocation algorithms. The proposed DBA will improve network performance in terms of resource utilization, network throughput, and packet delay, and thus provide near-optimal network services to end users. Also, the DBA can support differentiated services over an EPON access network. To validate the proposed algorithm, a discrete-event simulator will be developed.

### **1.4 Thesis Contributions**

In this thesis, we propose a novel DBA algorithm, called per-slot DBA (PSDBA) algorithm, to efficiently and fairly allocate bandwidth among different users in an EPON system. The PSDBA algorithm makes use of the excessive bandwidth of lightly-loaded ONUs to better meet the needs of heavily-loaded ONUs and dynamically allocates the excessive bandwidth to each heavily-loaded ONU on a

per-slot basis. Moreover, it can support differentiated services by integrating priority queue management.

The PSDBA algorithm has the following advantages.

1. Reduced packet delay. -In the DBA algorithm in [ASSI03], bandwidth allocation is performed on a per-frame basis. That is, bandwidth allocation is only carried out each time all the requests from ONUs are received at the OLT. Furthermore, the bandwidth allocation decisions for all ONUs are made at a time. An inter-frame idle time is generated due to propagation delay and it is equal to the round trip time plus computation time in the worst case. This idle time causes increased packet delay. In the PSDBA algorithm, a bandwidth allocation decision is made on a per-slot basis. In this way, this so-called inter-frame idle time is eliminated and thus average packet delay is reduced.
2. Improved system throughput. -In a system performing a per-frame bandwidth allocation the idle time exists between consecutive frames. Bandwidth in this idle time is completely wasted. This inter-frame idle time is also called “gap”. In this thesis, the term “gap” is interchangeable with the term “inter- frame idle time”. Although some methods have been given to minimize this gap, their efficiency is quite limited in many cases. In the PSDBA algorithm, the information used in calculating the bandwidth granted to each ONU is always updated. This information is a list of

bandwidth requirements containing up to  $N-1$  items of most *recent* requests that the OLT receives. Here,  $N$  denotes the number of ONUs in the system. In this way, the gap between consecutive frames is completely eliminated.

3. Maintained ONUs transmission order. -In PSDBA algorithm, the data transmission from different ONUs is always maintained in the same order. This can help to smooth the jitters in transmission.

A discrete event simulator is designed and developed in JAVA language. The simulation study shows that the PSDBA algorithm outperforms a well-known algorithm that allocates bandwidth on a per-frame basis. Further, the simulation results demonstrate that the PSDBA algorithm can achieve improved performance with and without considering differentiated services for the incoming traffic.

## **1.5 Thesis Organization**

This thesis is organized in five chapters. Chapter 1 introduces the background knowledge in optical access networks. The thesis motivations, objectives and contributions are also presented. Chapter 2 introduces EPON technologies and the key issues in an EPON network. Polling mechanisms as well as a comprehensive survey on various dynamic bandwidth allocation algorithms are presented. Chapter 3 describes the PSDBA algorithm with differentiated service support in great detail. Chapter 4 describes the simulation model and results. Performance evaluation and

analysis are also presented based on the simulation results. Chapter 5 gives the conclusions and the open issues for future research.

# **Chapter 2 POLLING MECHANISMS AND BANDWIDTH ALLOCATION ALGORITHMS IN EPONs**

## **2.1 Introduction**

EPON is considered as the most attractive solution to solve the “*first mile*” bottleneck problem for next-generation broadband access networks due to the convergence of low-cost Ethernet equipment and low-cost fibre infrastructure. A main feature of an EPON system is the use of a shared transmission channel among all users in the upstream direction. Because of this property of an EPON, to increase transmission efficiency, a multiple access arbitration mechanism must be deployed to avoid data collision and in the meantime to fairly share the channel capacity.

In this chapter, the EPON technologies and architectures are first introduced, and several key issues in designing a broadband EPON access network are pointed out. Then an overview of MPCP protocol and some existing proposed polling

protocols is presented. Finally, a comprehensive review of the previously proposed DBA algorithms in the literature is given.

## **2.2 EPON: Technologies and Architectures**

Like other PON technologies, EPON is a point-to-multipoint fibre optical network with no active equipment in the transmission path from source to destination. The only interior equipment used in an EPON are passive components, such as optical fibre, splice, and splitter. All transmission in a PON is carried out between the OLT and ONUs.

Typically, an EPON network is connected in tree topology and shown as in Figure 2.1, which consists of one OLT, a 1:N passive star coupler (or splitter/combiner), multiple ONUs. At the root of the tree is an OLT, which is the service provider equipment residing at the central office (CO). The OLT acts as a traffic distributor or aggregator, connecting the optical access to a metropolitan area (MAN) or wide area networks (WAN). The OLT is connected to the passive coupler through a single optical fibre. The passive star coupler is located a long distance away from the CO but close to the customer premises. ONUs are located at either the curb (FTTC solution), building (FTTB solution) or home (FTTH solution). Each ONU is connected to the passive coupler through a dedicated short distance optical fibre. The distance between the OLT and each ONU typically

ranges from 10 km to 20 km. ONUs buffer data received from the attached subscribers and convert the data between optical and electrical domains.

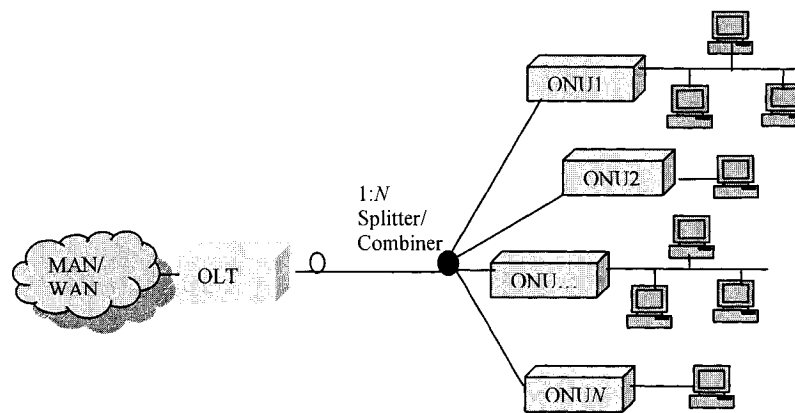

**Figure 2.1 A Typical EPON Architecture**

In the downstream direction (i.e., from the OLT to ONUs), an EPON system may be viewed as a point-to-multipoint network [KRAM02A], where Ethernet frames transmitted by the OLT pass through a 1: N passive splitter (where N typically between 4 and 64) and broadcast to each ONU. Each ONU extracts the data destined for it based on its media access control (MAC) address.

In the upstream direction (i.e., from ONUs to the OLT), an EPON may be viewed as a multipoint-to-point network [KRAM02A], where multiple ONUs transmit data packets to the OLT through the N: 1 passive combiner. All ONUs have to share the transmission capacity and resource. Due to the directional property of a passive combiner, packets from any ONU can only reach the OLT, not other ONUs. For this reason, conventional contention-based media access, e.g.,

the carrier sense multiple access with collision detection (CSMA/CD) protocol is not preferred because of its channel inefficiency. To solve this problem, a revised CSMA/CD protocol was proposed in [CHOI02], where a loop-back technique is used to gain high transmission efficiency. The problem of this technique is that each ONU has to add an additional receiver for the upstream data and a carrier sense circuit. This will increase network cost. Another disadvantage of this technique is that it is very difficult to support QoS function because contention-based media access cannot provide guaranteed bandwidth to each user.

Another possible solution to avoid collisions is to use wavelength division multiplexing (WDM) [KRAM02B], which allows each ONU to operate at a different wavelength, thus avoid interfering with other ONUs' transmission. This solution is simple to implement, but the OLT would require a tunable receiver or a receiver array to receive data on multiple wavelength channel. Moreover, it requires each ONU to use a fixed transmitter at a different wavelength, which will cause an inventory problem. Although the inventory problem can be solved by the use of tunable transceivers, such transceivers are too expensive to use at this current time. Thus, WDM solution is cost-prohibitive and is not considered as an attractive solution in the short term.

Compared with CSMA/CD and WDM, time division multiple access (TDMA) on a single wavelength is more attractive for upstream transmission, where 1550 nm wavelength for downstream transmission and 1330 nm wavelength for upstream transmission [KRPE02A]. In the upstream direction, all ONUs share

the same transmission medium. In this solution, the OLT allocates each ONU a time-slot or a transmission window for data transmission. Each ONU buffers data packets from different users until they are transmitted in the assigned time-slot. When the assigned time-slot arrives, the ONU will burst out all packets at full upstream channel speed. Moreover, it requires only one single wavelength for all ONU transmission and a single transceiver for the OLT, and thus is a cost – effective solution. Also note that using TDMA does not prevent EPON from being upgraded to WDM in the future [ZHEN05A].

### **2.3 Key Issues in EPON**

To successfully design and implement an EPON system, several key issues need to be addressed: multiple access, packets scheduling, bandwidth allocation, and QoS support [ZHEN05A].

Multiple access control mechanism plays an important role in achieving good network performance. There are two basic problems that have to be solved: channel separation and multiple access. As discussed earlier, to avoid collisions, TDMA on a single wavelength is considered as a more attractive solution among other approaches. However, this will require packet scheduling.

The goal of packet scheduling is to ensure efficient upstream transmission from all ONUs as well as to avoid packet collisions from different ONUs. In an EPON system, it is the OLT's responsibility to grant a time-slot to each ONU. The

OLT also has the knowledge of the round-trip time between the OLT and ONUs for each ONU. Thus, the OLT can calculate the data transmission start time and grant bandwidth for next ONU. In this way, packet scheduling is carried out to achieve our goal. Another responsibility of the OLT is to determine the order of the transmission from different ONUs, which has a great impact on network performance. This is done one cycle ahead. The OLT determines the order based on different scheduling algorithms, which are discussed in detail in the later sections.

In an EPON system, due to the limited bandwidth of the upstream channel, it may not always be able to provide sufficient bandwidth to meet the bandwidth demand of all end users. An available solution is to assign a time-slot to each ONU, and each ONU can only transmit in its assigned time slot. While assigning a fixed time slot to each ONU regardless its demand is simple, this scheme cannot adapt to burst traffic and may waste bandwidth. For this reason, an efficient bandwidth allocation algorithm becomes a critical issue to design an EPON system. There are two basic categories of bandwidth allocation algorithms: static allocation and dynamic allocation. The desirable solution is that the OLT can dynamically allocate bandwidth to each ONU based on its demand instantaneously. Thus, a fair and effective bandwidth allocation scheme has to be carefully designed.

Performance of packet-networks, particularly in EPON, can be conventionally characterized by several parameters: packet delay, throughput, delay variation (jitter), and packet loss ratio. Quality of Service (QoS) is the ability

of a network to provide different levels of service assurances to the various forms of traffic. EPON is expected to provide a variety of network services with diverse QoS requirements to all end users. Various traffic flows are classified into a limited number of classes to be differentially serviced. Accordingly, there are multiple queues for different classes in an ONU. A newly arrived packet is first classified by its type-of-service (ToS) field and buffered into the corresponding queue [XIE04]. According to 802.1 Q, an ONU can support up to eight priority queues. There are two mechanisms for scheduling the transmission of packets buffered in the different priority queue - inter-ONU and intra-ONU.

## **2.4 Polling Mechanisms**

In TDMA, to increase bandwidth utilization for an EPON access network, it is desirable that the OLT dynamically allocates a variable time-slot to an ONU based on the instantaneous bandwidth demand of that ONU. For this purpose, a polling mechanism has been widely considered [KRAM02A][MA03][ASSI03][AN03][BYUN03]. A polling protocol is used to allocate bandwidth for each ONU based on its demand and flexibly arbitrate the transmissions of multiple ONUs, which can significantly increase bandwidth utilization and thus improve network performance. To support polling, MPCP has been developed and standardized by the IEEE 802.3ah Ethernet in the First Mile Task Force [IEEE802A].

### 2.2.1 MPCP

MPCP is a signaling protocol (control plane) for arbitrating the transmissions from multiple ONUs to the OLT. Although MPCP is not concerned with particular bandwidth allocation, it is meant to facilitate the implementation of various allocation algorithms in EPON. MPCP is a frame-based TDMA protocol based on 64-byte MAC control message. There are five MAC control messages defined in MPCP: GATE, REPORT, REGISTER\_REQ, REGISTER, and REGISTER\_ACK. GATE and REPORT messages are used for MPCP in the normal operation mode. The GATE message is used by the OLT to allocate a transmission window to an ONU. The REPORT message is used by an ONU to report its local queue length to the OLT. REGISTER\_REQ, REGISTER, and REGISTER\_ACK messages are used for the MPCP in the auto-discovery mode to discover and register a newly connected ONU, and to collect related information for that ONU, such as the round-trip delay and MAC address.

Figure 2.2 illustrates the GATE message operation [PESA03], which is responsible for assigning bandwidth to ONUs. A GATE message is generated in the MAC control client layer and is time stamped in the MAC control layer. It typically contains one or multiple sets of granted start time and a granted transmission length as well as a 4-byte timestamp, which is used to calculate the round-trip time between the OLT and an ONU. When an ONU receives a GATE message matching its MAC address, it will program its local register with the value of granted start time and granted transmission length. In the meanwhile, the ONU

will also adjust its local clock to that of the timestamp extracted from the received GATE message in order to maintain synchronization with the OLT. At the granted start time, the ONU will start its transmission for up to the granted transmission length. Note that, no packet fragmentation is allowed during the transmission. If the next packet cannot be transmitted in the current assigned time-slot, it will be deferred to the next time-slot.

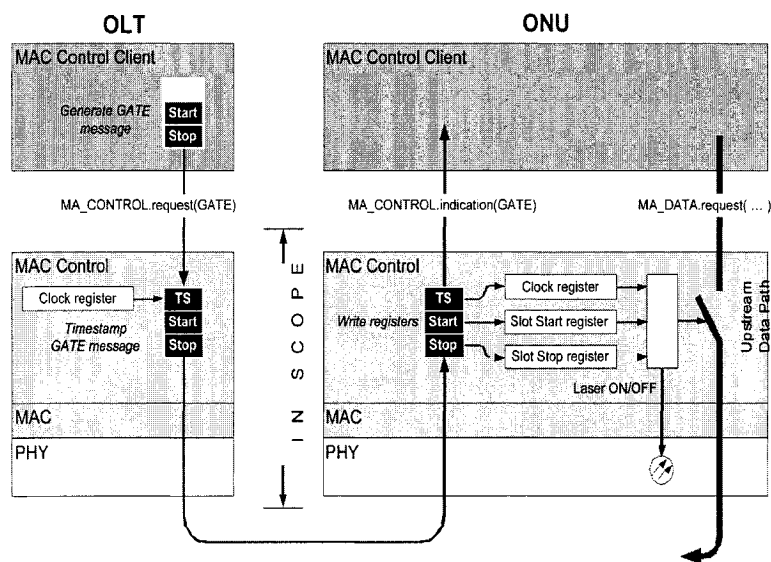

Figure 2.2 GATE message [PESA03]

Figure 2.3 illustrates the REPORT message operation [PESA03], which is responsible for reporting local information at ONUs. A REPORT message is sent by an ONU in the assigned transmission windows together with data frames. It can be transmitted automatically or on demand at the beginning of the time-slot, or at the end depending on the bandwidth request approach implemented by the ONU. A REPORT message is generated in the MAC control client layer and is time

stamped in the MAC control layer. It typically contains the requested bandwidth or window size based on the ONUs queue size. The ONU should also account for additional overhead in its request, which includes a 64-bit frame preamble and a 96-bit inter-frame gap (IFG) associated with each frame. Upon receiving the REPORT message, the OLT passes the message to the MAC client layer, which is responsible for bandwidth allocation and recalculation of the round trip delay to the source ONU. To support differentiated services, each ONU may need to report the status of its individual priority queue [CHOI02] and the OLT can choose to send one or multiple priority grants within the same GATE message depending on the bandwidth allocation algorithm implemented.

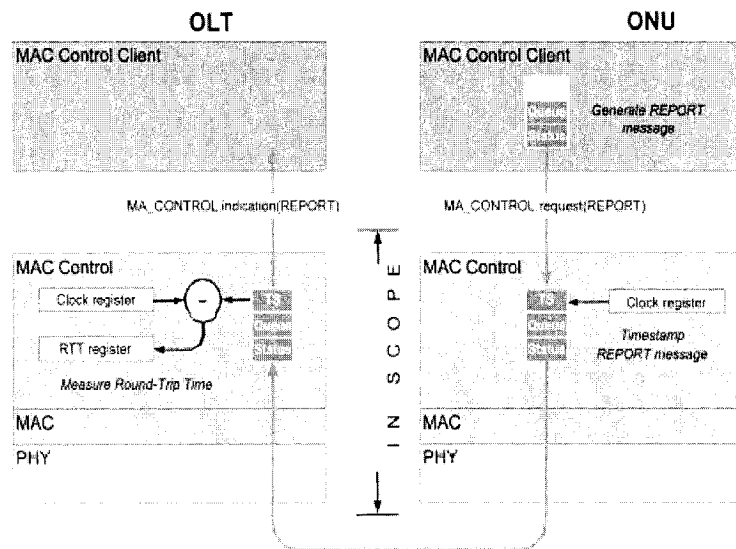

Figure 2.3 REPORT message [PESA03]

## 2.2.2 Related Work on Polling Protocols

Based on MPCP, there is a variety of polling mechanisms proposed in the literature.

### 2.2.2.1 Broadcast Polling

In [XION04], an uplink access scheme for EPONs, called broadcast polling (BP) has been proposed. In the BP scheme, the OLT only sends one GATE message to inform all ONUs of their bandwidth grant information in every cycle. This GATE message is called a grant. The grant for cycle  $N$  is generated on the basis of reports from cycle  $N-2$  due to the fact that the OLT has to know all ONUs bandwidth requirements.

In the BP scheme, the OLT keeps the requested window size of each ONU and the round-trip time (RTT) to each ONU in a polling table. It is assumed that the current cycle is  $N-2$  now. Once the OLT receives all REPORT messages from cycle  $N-2$ , it starts to allocate the bandwidth according to bandwidth allocation scheme. The GATE message consists of the assigned bandwidth and transmission start time. The destination address of this GATE message is a broadcast address so that all ONUs can receive it. When the OLT is broadcasting the grant for cycle  $N$  to each ONU in cycle  $N-2$ , cycle  $N-1$  has already started. In this way, channel utilization is improved. Upon receiving the grant, each ONU will get its grant information. It is possible that for a particular ONU the transmission would have not started yet when it has received its GATE message. In this case, the ONU has to put the GATE information into its register. In the meantime, in the upstream direction, the OLT receives the ONU's REPORT message from cycle  $N-1$ , it calculates the RTT and updates the polling table with the ONU's demand and new RTT value. Once all ONUs REPORT messages from cycle  $N-1$  are received, the

OLT can start generating the grant for cycle  $N+1$ . The process will repeat as it is in cycle  $N-2$ .

In summary, this broadcast polling scheme is simple to implement. However, the OLT has to know all ONU's requirements. Further, it uses bandwidth demand information collected in two cycles ahead to allocate bandwidth for each ONU in current cycles. Thus, the information may be not up to date. This may result in packet delay and deterioration of the network performance.

#### **2.2.2.2 Non-Broadcast Polling**

In contrast to broadcast polling, there are several non-broadcast polling approaches that have been proposed. In [CHOI04], the author proposed an OLT\_based polling algorithm, called the cyclic polling algorithm, which is to dynamically allocate bandwidth for differentiated class of service in EPON. In this scheme, every ONU is polled by the OLT periodically. The objective of this scheme is to increase the downstream capacity for user traffic when upstream traffic load is low. The idea behind it is that the available bandwidth for down stream traffic is restricted critically due to the GATE messages when only a little upstream traffic is waiting. The simulation results show that the cyclic polling scheme with the MPCP guarantees near total downstream bandwidth.

In [KRAM02A] G. Kramer et al. proposed an interleaved polling algorithm, where the next ONU was polled before the transmission from the previous ONU

had arrived. This is not difficult to implement because the upstream and downstream channels are independent, and the OLT maintains a polling table including the bandwidth demand and the RTT for each ONU. This polling table is dynamically updated by each REPORT message in the previous polling cycle and is used to calculate the transmission starting time for the next ONU. It has been shown that the interleaved polling protocol can significantly improve upstream channel utilization. With this protocol, however, the OLT can only allocate bandwidth based on the ONUs bandwidth demand already received. It is unable to make a more intelligent decision for bandwidth allocation, which can account for the bandwidth demand of all ONUs. Such intelligence is very important in providing better network services to end-users.

To achieve more intelligent bandwidth allocation, the author in [ZHEN05A] introduced a variation of the interleaved polling protocol called interleaved polling with stop. Like the interleaved polling protocol, this protocol allows the OLT to perform bandwidth allocation based on the bandwidth demands of all ONUs at the end of each polling cycle and thus make a more intelligent decision.

## **2.5 Bandwidth Allocation Algorithms**

Since an efficient bandwidth allocation algorithm (BA) is very important in EPON access networks, much research work has been carried out to address this issue. As mentioned earlier, there are two basic categories of bandwidth allocation algorithms: static and dynamic. Dynamic bandwidth allocation (DBA) schemes can

be further divided into two categories: Statistical Multiplexing and QoS guaranteed, as shown in Figure 2.4. Another way to classify bandwidth allocation algorithms is: centralized and decentralized. In this section, we give a comprehensive survey on different BA algorithms proposed to date for EPONs. We focus on DBA algorithms because allocating bandwidth on demands of ONUs can improve bandwidth utilization.

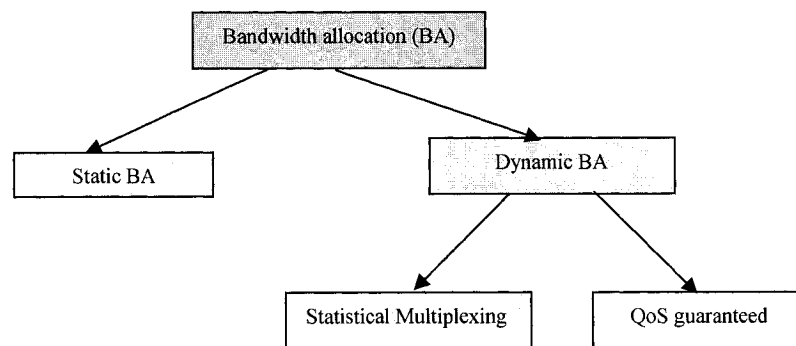

Figure 2.4 Bandwidth allocation algorithms classifications

### 2.2.1 Static Bandwidth Allocation Algorithm

From the above discussion, one can see that TDMA is considered as an attractive solution for upstream transmission in EPONs. In TDMA, the time-sharing techniques can be either static or dynamic depending on the time-slot or transmission window allocated to each ONU, which can be either static or dynamic. In static bandwidth allocation, each ONU is allocated a fixed time-slot to transmit

data regardless of its demands. In dynamic allocation, bandwidth allocation is assigned proportionally to the reported queue length [NIPE04]. In [KRAM01], the author studied the performance of EPON using a fixed bandwidth assignment algorithm, in which all traffic belonged to a single class, i.e., no service differentiation. While this scheme is simple, it has a drawback, which is the fact that it is not possible to implement statistical multiplexing among ONUs. This is because each ONU is allocated a fixed time-slot; lightly-loaded ONUs will probably under utilize their allocated slots even under very heavy traffic load, while the time-slots of those heavily- loaded ONUs are overflowed. This will cause increased packet delay. This phenomenon will eventually deteriorate the network throughput. For this reason, static bandwidth allocation is not preferred.

## **2.2.2 Dynamic Bandwidth Allocation (DBA) Algorithms**

In this section, we present a comprehensive overview of different DBA algorithms, including statistical multiplexing schemes and QoS support schemes.

### **2.2.2.1 Statistical Multiplexing Scheme**

The typical method of statistical multiplexing in the literature is the “Interleaved Polling with Adaptive Time”, called *IPACT* proposed in [KRAM02A]. In this approach, the OLT polls the ONUs individually and issues transmission grants to them in a round-robin fashion. The granted window size is variable depending on the amount of frames buffered at the respective ONUs, as reported by the respective ONUs using REPORT messages. *IPACT* keeps track of the round-trip

times of all ONUs and uses an interleaved polling approach, where the next ONU is polled before the transmission from the previous one has arrived. In this way, network utilization is highly improved.

In IPACT, the cycle time is not fixed but adapts to the instantaneous bandwidth requirements of the ONUs. Also, it uses a maximum transmission window (MTW) to prevent the ONUs with high data volume from monopolizing the transmission bandwidth. The OLT allocates the upstream bandwidth to the ONUs in one of the following ways [ZHEN05A]:

- Fixed allocation: The OLT ignores the requested window size and always grants the maximum transmission window (MTW) size to each ONU. Thus, the cycle time is constant.
- Limited allocation: The OLT grants the requested number of byte, but not exceeding the MTW. This scheme assumes that there is no more packets arrived after the ONU sent its request. This is somehow not very practical. As a matter a fact, because of the round trip time, there might be more packets arriving during the instant an ONU sent a REPORT message to the instant the ONU receives a GATE message. In this case, those newly arrived packets may not be able to be transmitted in the current cycle, resulting in increased packet delay.
- Constant credit service: The OLT grants the request number of bytes plus a constant credit. The size of the credit is constant no matter how

large is the requested window size. Note that the credit size may have an impact on the network performance.

- Linear credit: The OLT grants the request number of bytes plus a credit that is proportional to the requested window size. The idea behind is that network traffic usually has some degree of predictability.
- Elastic allocation: This algorithm attempts to overcome the limitation of assigning at most one fixed MTW to an ONU within one cycle. The maximum window  $W_{max}$  is granted in such a way that the accumulated size of the last  $N$  grants does not exceed  $N*W_{max}$ , where  $N$  denotes the number of ONUs. In this way, if only one ONU has data to send, it may get a granted window size up to  $N*W_{max}$ .

Among these schemes, the limited allocation scheme exhibits the best performance [KRAM02B].

In summary, *IPACT* improves the channel utilization efficiency by using carefully interleaved polling message. It provides statistical multiplexing and dynamically allocates upstream bandwidth according to the traffic demands of the ONUs within adaptive polling cycles. *IPACT* deploys an efficient in-band signalling approach that avoids using extra Ethernet frames for control. Moreover, *IPACT* uses a maximum transmission window (MTW) to achieve throughput fairness among ONUs. Although *IPACT* is a well-designed dynamic bandwidth

allocation for EPON networks, it does not support QoS and is not suitable for delay and jitter sensitive services because of a variable polling cycle time.

#### **2.2.2.2 DBA with QoS Support**

There have been numerous proposals in the literature to address the problem of dynamic bandwidth allocation with QoS support. Some of the algorithms classified ONUs into groups based on their QoS levels or Service Level Agreements (SLAs) with their service providers, such as those proposed in [MA03] and [XION04]:

##### *a) Bandwidth Guaranteed Polling (BGP) Algorithm*

The BGP method proposed in [MA03] divides ONUs into the two disjoint sets of bandwidth guaranteed ONUs and best effort ONUs based on the SLA. All these ONUs share the total upstream bandwidth, which is divided into equivalent units. The OLT maintains two Entry tables, one for bandwidth guaranteed ONUs and the other for best effort ONUs. Entries in the guaranteed bandwidth ONUs table that are not occupied can be dynamically assigned to best-effort ONUs. The OLT polls the best effort ONUs during the entries that are not used by the bandwidth guaranteed ONUs in the order they are listed in the best effort table. In this way, this approach explicitly provides differentiated service to different users with various bandwidth requirements. The main drawback of this algorithm is that it divides ONUs into two types, which is not the case in future emerging EPON access networks, where one single ONU must be capable of provisioning different services for different user requirements. Moreover, this algorithm is neither

consistent nor to be standardized with the MPCP arbitration mechanism proposed for EPON.

b) *Broadcast Polling (BP) Algorithm*

The BP method classifies ONUs into groups based on QoS level and has been proposed in [XION04]. This algorithm gives a guaranteed forwarding service to the ONUs of class 1, a best effort service level to the ONUs of class 3, and the service level between class 1 and 3 to the ONUs of class 2. In the BP scheme, the OLT has known all ONUs' bandwidth requirements before allocating bandwidth to the ONUs, and only one GATE message is sent to them in every cycle. Since the ONUs have to be divided into three classes, it has the same drawback of BGP scheme. Moreover, in BP, the grant for cycle N is generated on the basis of the reports from N-2, this may result in the request information being not up to date and will increase packet delay.

There are many other DBA algorithms with QoS support proposed in the literature. In [XIE04], the authors proposed a class-based bandwidth allocation scheme to provide differentiated services. With this scheme, an ONU reports its instantaneous traffic load for each traffic class separately, and the OLT uses this information to proportionally allocate bandwidth according to the ratio of the request of a single class to the total request. Thus, it can be adaptive for dynamic traffic load. The OLT first allocate the bandwidth for different traffic class, then further distributes the bandwidth to one class among all requesting ONUs. This

forms a two-layer bandwidth allocation scheme (TLBA). To avoid a class from monopolizing bandwidth under heavy load, a weight is set for each class to determine a bandwidth threshold. With the same class, all ONUs fairly share the bandwidth following the max-min policy. Although this scheme can allow all ONUs to fairly share the upstream bandwidth according to their bandwidth demands, it increases the gap time needed between two adjacent time slots to avoid overlapping of signals from different ONUs because of the layered structure.

Reference [CHOI02] proposed a dynamic bandwidth allocation algorithm for multimedia services over EPON, where traffic in each ONU is placed into three queues. The size of the three priority queues in each ONU is reported to the OLT. The OLT issues grants separately for each of the priorities based on their respective demands in each of the ONUs. The main feature of this approach is that it uses strict priority queuing and control message formats that handle classified bandwidths using MPCP. This will result in starvation of ONUs that have more low priority traffic.

Another scheme that combines dynamic bandwidth allocation with priority scheduling was proposed in [KRAM02A], which may be viewed as the first contribution on DBA with QoS. The authors used a combination of limited service scheme (inter-ONU scheduling) and a priority queuing (intra-ONU scheduling). They found some unexpected results: queuing delay for some traffic classes increases when the network load decreases, a phenomenon they called *light-load*

*penalty*. Since the light-load penalty affects only some traffic classes, it violates the fairness property among the traffic classes. This appears to be caused by a fact that during the ONU waiting time, which is between ONU's sending a REPORT and the transmission of the reported data, more packets may arrive to the queue. Newly arrived packets may have high priority than some packets already stored in the queue. They will pre-empt lower priority traffic that arrived before the queue reporting and will be transmitted in the next transmission slot before those low-priority packets. Since these new packets were not reported to the OLT, the granted slots cannot accommodate all the stored packets. This causes some low-priority packets to be left in the queue. This situation may repeat many times, causing some low-priority packets to be delayed more multiple cycle times. When the load increases, the queue behind a lower-priority packet grows fast and the light-load penalty decreases. The authors proposed two different methods to eliminate the "*light-load penalty*": two-stage buffers and CBR credit. Although the two-stage method eliminates the light-load penalty, it causes increased delay for higher priority traffic. On the other hand, the CBR credit method attempts to predict the amount of high priority packets arriving between the queue report and the arrival of the granted time-slot, and adjust the granted window size accordingly. However, this method only partially eliminates the light-load penalty and requires external knowledge of the traffic arrival.

To better alleviate the light-load penalty, the authors in [ASSI03] proposed a DBA algorithm that supports differentiated services for different user

requirements for EPON access networks. With this scheme, a traffic priority queuing is combined with a specific bandwidth allocation algorithm that is not confined to limited slot allocation. A contribution of this scheme is to fairly distribute the excessive bandwidth among highly loaded ONUs. In this scheme, a priority scheduler is employed for scheduling packet transmission. In other words, only those packets that arrive before the time of the ONU sending the last REPORT message to the OLT are scheduled to transmit in the current time slot. Those packets (even with high priority) have to be deferred to the next time-slot if they arrive after the ONU has sent a REPORT messages to the OLT. Thus, low priority traffic would not be starved for the transmission. For every transmission grant cycle, each ONU is allowed to report the requests of three priority classes to the OLT, and its granted bandwidth also includes three parts accordingly. This option put the priority scheduling under the OLT control. Note that with this DBA scheme, the OLT assigns bandwidth in a per-frame basis. That is, bandwidth allocation is only carried out each time all the requests from ONUs are received. This will result in packets' waiting time at ONUs, and thus increase average packet delay. The authors attempted to employ an early allocation scheme to reduce the waiting time of the upstream channel. However, this still cannot help to completely eliminate the unnecessary waiting time. As a result, the system efficiency is still limited in many cases.

## 2.6 Summary

In this chapter, EPON technologies and architectures have been introduced. EPON is an attractive and promising solution for supporting broadband applications in local access networks because of its high speed, low cost, and interoperability. MPCP is a signalling protocol defined for the arbitration of the transmission of different ONUs and it resides at the MAC control layer. It is mentioned that MPCP does not specify any particular allocation algorithm. Therefore, designing efficient and fair bandwidth allocation algorithms based on MPCP becomes a critical issue in an EPON system. The objectives of designing such algorithms include efficient network resources utilization, transmission collision avoidance, increased network throughput and reduced packet delay.

In the next chapter a novel per-slot dynamic bandwidth allocation algorithm, called per-slot DBA (PSDBA) algorithm, designed to achieve better network performance, will be presented. In this algorithm, the MPCP and DBA algorithm are combined with queue management to provide differentiated service support to multiple users.

## **Chapter 3      A NOVEL PER SLOT BASED DBA ALGORITHM WITH QoS SUPPORT**

### **3.1      Motivations**

In the real world, different ONUs may have different bandwidth requirements due to the differences in subscribers' SLA. For this reason, the DBA in [ASSI03] predefines a minimum guaranteed bandwidth,  $B_i^{\min}$  for each ONU. Considering the burst nature of network traffic, some ONUs may have less traffic than their minimum guaranteed bandwidth to transmit while other ONUs may have more traffic than their minimum guaranteed bandwidth to send within one cycle. To improve network utilization, the excessive bandwidth resulted from those lightly-loaded ONUs can be allocated to those heavily-loaded ONUs to better meet the bandwidth demands of the heavily-loaded ONUs.

One of the important characteristics of the DBA algorithm in [ASSI03] is that the OLT assigns bandwidth on a per-frame basis. That is, bandwidth allocation is only performed at the time when all the REPORT messages from ONUs are received. However, some idle time in the upstream channel, which is also called

gap as defined earlier, exists between consecutive frames. This results in some bandwidth being wasted in the upstream channel. Figure 3.1 illustrates how such a gap is created in the implementation of the DBA scheme. This gap is equal to a round trip time between the OLT and ONUs plus the DBA computation time. In a typical EPON system, the overhead due to such gap can be ten percent for a hundred-microsecond propagation delay in a two-millisecond frame. To reduce the gap, an early allocation mechanism was proposed in [ASSI03]. In this method, the OLT can schedule ONUs whose requested bandwidth  $R_i < B_i^{\min}$  instantaneously without waiting. Those who are requesting  $R_i \geq B_i^{\min}$  will have to wait all REPORT messages being received and the DBA algorithm has to compute their bandwidth allocation, as shown in Figure 3.2.

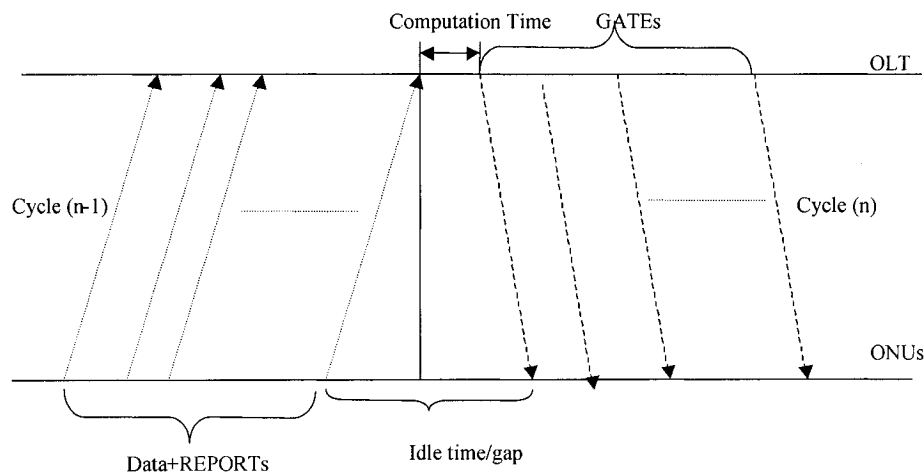

**Figure 3.1 DBA with idle time**

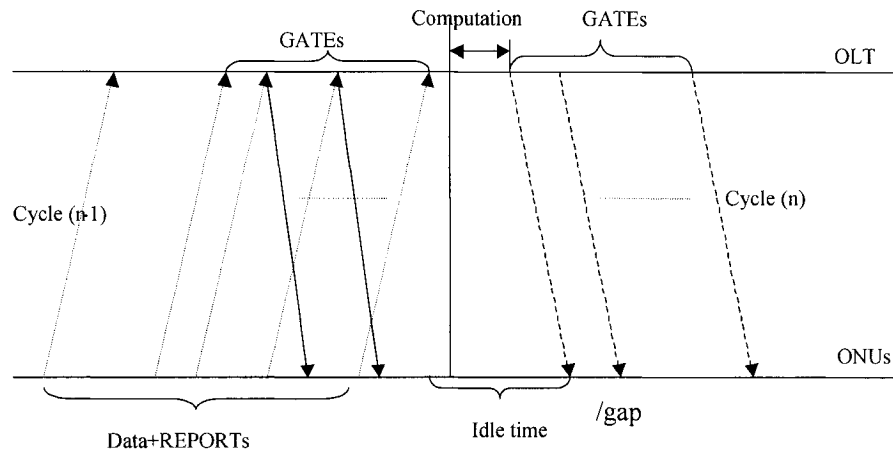

**Figure 3.2 Enhanced DBA with less idle time**

However, this method still cannot resolve the problem or remove the gap completely. For example, in the case of a light load, because the requested bandwidth from most ONUs is less than their minimum guaranteed bandwidth, those ONUs are assigned bandwidth without waiting based on the early allocation scheme. In this case, this scheme works well. However, under very heavy load, the bandwidth allocation to most ONUs has to be delayed until the OLT receives all requests. In this case, the gap time is still kept large or even unreduced at all, and thus the performance of this scheme is not very satisfactory.

For this reason, a novel per-slot DBA (PSDBA) algorithm with QoS support is proposed to eliminate the gap time for achieving high channel utilization. The PSDBA algorithm is described in detail in the following sections.

## 3.2 Network Model

In this section, the network model used in the PSDBA scheme is presented. In this thesis, an EPON access network consists of an OLT and  $N$  ONUs, as shown in Figure 3.3. In this network model,  $R_u$  Mbit/s is considered to be the data rate from users to an ONU and  $R_N$  Mbit/s to be the capacity of the upstream link from an ONU to the OLT. Line capacity for each link is the same in upstream and downstream direction. The link capacity is usually much higher than the average rate at which users send packets. However, one should note that if  $R_N \geq N * R_u$ , the bandwidth utilization problem does not exist, since the system throughput is higher than the peak aggregated load from all ONUs.

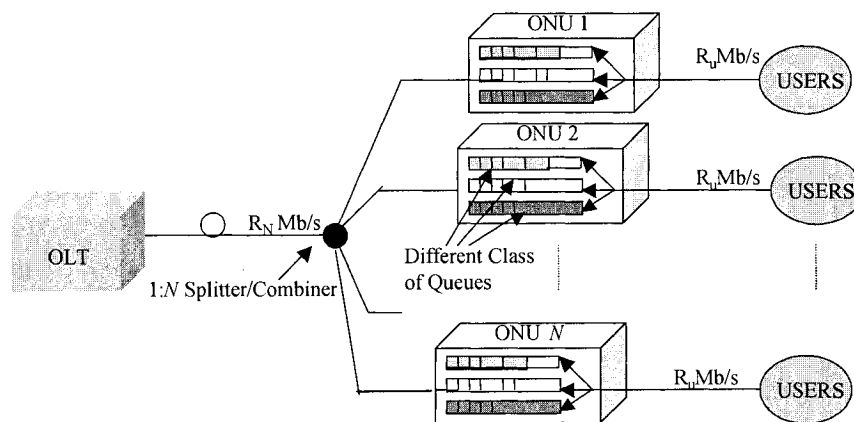

Figure 3.3 A network model of an EPON system

Every ONU is located at a certain distance away from the OLT and has a certain propagation delay. A downstream propagation delay and upstream propagation delay are the same because only a single fibre is used for bi-directional transmission.  $S$  denotes the largest distance between the OLT and an ONU.

In this thesis, an EPON system can support Differentiated Services (DiffServ) and offer various levels of QoS. Network services are classified into three priorities as defined in [BLAK98]: namely the expedited forwarding (EF), the assured forwarding (AF), and the best effort (BE). The EF service (primarily voice and video delay sensitive applications) requires very strict requirements and demands a constant, low end-to-end delay and jitter. AF is intended for services that are not delay sensitive but which require bandwidth guarantees. The BE traffic has no strict specification requirements regarding traffic properties. To support these three classes, each ONU is equipped with three queues serving these three priority classes, denoted by  $P_0$ ,  $P_1$  and  $P_2$ , respectively.  $P_0$  is the highest priority and  $P_2$  is the lowest priority, as shown in Figure 3.3. When a packet is received from a user, the ONU classifies its type and places it in the corresponding queue. The queues in each ONU share a common memory of size  $Q$  bytes. Note that a guard time  $T_g$ , is considered accounting for the receiver on and off time, receiver recovery time, round trip delay and other optical related issues. The granting cycle is denoted by  $T_{cycle}$ . It is the time during which all active ONUs can transmit and report to the OLT. For every transmission grant cycle, each ONU is allowed to report the total request bandwidth  $R_i$ , which contains the request of three priority classes to the OLT, denoted by  $H_i$ ,  $M_i$ , and  $L_i$  respectively. Its granted bandwidth also includes three parts accordingly.

In this model, for each ONU a minimum guaranteed bandwidth based on its SLA is defined and denoted by  $B_i^{\min}$ , i.e., the minimum guaranteed bandwidth (in bytes) allocated by the OLT under heavy load operation. To improve the network performance in terms of average packet delay and system throughput, the excessive bandwidth (denoted as  $B_{total}^{excess}$ ) contributed from those lightly-loaded ONUs is fairly allocated to those heavily-loaded ONUs.

### 3.3 Polling Protocol Design

It is shown that in [KRAM02A] the regular interleaved polling protocol is unable to adopt sophisticated bandwidth allocation algorithms, which takes into account the bandwidth demand of all ONUs; so its ability to support differentiated services is limited. The interleaved polling with stop, introduced in [ZHEN05A], allows the OLT to allocate bandwidth on a per-frame basis, that is, the OLT allocates bandwidth based on the bandwidth demands of all ONUs at the end of each polling cycle. This polling scheme results in inter-frame idle time of upstream channel. An early allocation mechanism in [ASSI03] is employed to shorten this idle time and achieve high utilization. However, the idle time still exists in the upstream channel due to the propagation delay. To better solve this problem, a scheme that integrates interleaved polling approach with the PSDBA algorithm is proposed to support QoS for different end users.

In the PSDBA-based scheme, the OLT acts as a central controller performing dynamical medium access arbitration for all ONUs. The REPORT and the GATE messages defined in IEEE 802.3ah are used to deliver control messages between the OLT and ONUs. Each ONU generates the REPORT message, which contains the demands of its individual priority queues. Upon receiving the REPORT message, the OLT first checks the total demand of the ONU and records this information. Scheduling a grant transmission is as follows. If the total request of an ONU is less than its minimum guaranteed bandwidth, the OLT can grant the requested bandwidth. If the total request of an ONU is more than its minimum guaranteed bandwidth, the OLT has to use the PSDBA algorithm to compute the allocated bandwidth, which is described in subsequent sections. The PSDBA algorithm distinguishes itself in that the OLT sends a grant to an ONU for its next grant arrival right before the data transmission ending time of its preceding ONU. Note that the preceding ONU of  $ONU_0$  is  $ONU_{N-1}$ .

Other than allocating bandwidth to an ONU, the OLT needs to calculate the transmission starting time of the ONU based on the granted bandwidth of each ONU. The GATE message containing the granted bandwidth and data transmission starting time then can be transmitted to the ONU by the OLT. When the granted transmission starting time arrives, the ONU can transmit its buffered data up to the granted length. A REPORT message is then sent by the ONU in the assigned transmission window together with data frames. The REPORT message contains the desired size of the next time slot based on the ONUs queue occupancy. Figure

3.4 illustrates a flow of GATE (G) and REPORT (R) messages for upstream transmission of three ONUs. Here, the guard time is ignored for ease of explanation of our strategy.

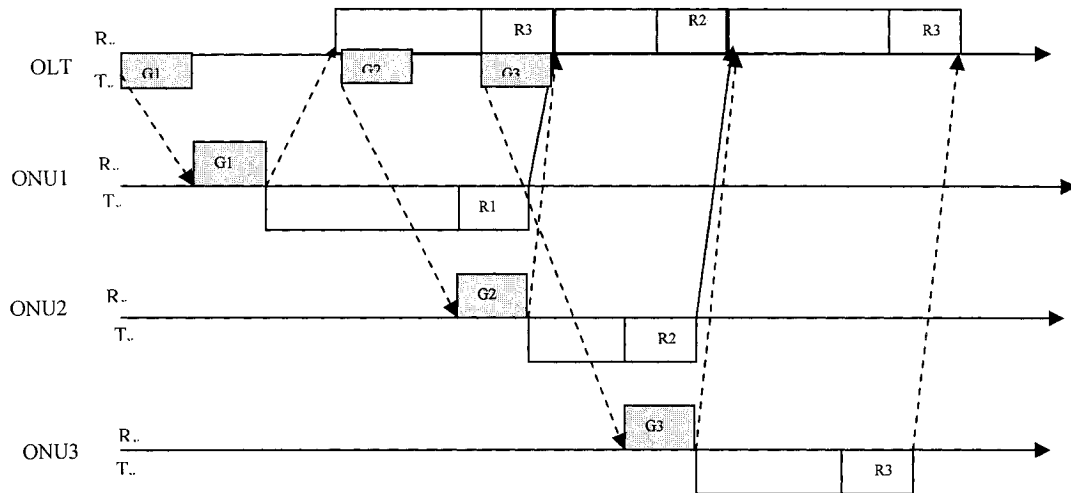

**Figure 3.4 A flow of GATE and REPORT message.**

In summary, an OLT-based interleaved polling approach is used to arbitrate the transmissions of multiple ONUs. With this approach, the next ONU is polled before the transmission from the previous ONU has arrived. The duration of each slot is dynamically changed based on the requested bandwidth in ONUs. Each ONU executes the same procedure driven by the GATE message received from the OLT. Note that here the issue of synchronization between the OLT and ONUs is not emphasized because it conforms to the MPCP protocol.

## **3.4 ONU Queue Management**

EPON is expected to provide a variety of network services with different QoS requirements for end users. Priority queuing and packet scheduling have been widely employed as effective solutions for supporting QoS.

### **3.4.1 Priority Queuing**

Priority queuing is considered as a useful and relatively simple method for supporting differentiated QoS [ASSI03]. Diffserv is an IETF framework for classifying network traffic into classes, with different service level for each class. Figure 3.5 shows a simple example of priority queuing, in which each ONU maintains three separate priority queues for the three classes: EF, AF, and BE. The queues in each ONU share the same memory buffer of fixed size. Data packets from end users are first classified by checking the type-of-service (ToS) field of the IP packets encapsulated in the Ethernet packets and then buffered into an appropriate priority queue. The queuing discipline is as follows: if a higher priority packet arrives and finds the buffer full, it can preempt a lower priority packet. If a lower priority packet arrives and finds the buffer full, it will be dropped. As a result, lower priority traffic may experience very long delays and increased packet loss, even resulting in a resource starvation. To address this problem, traffic policing can be placed at each ONU to control the amount of higher priority traffic of each user to be sent. The arriving packets are first classified and checked for the conformance with their SLA and then unnecessary traffic will be dropped. The higher priority traffic is always given favour and the

lower priority traffic is most likely to be dropped. However, some control methods may need to be employed to control the higher priority traffic to prevent them from monopolizing the channel capacity and exceed their SLAs.

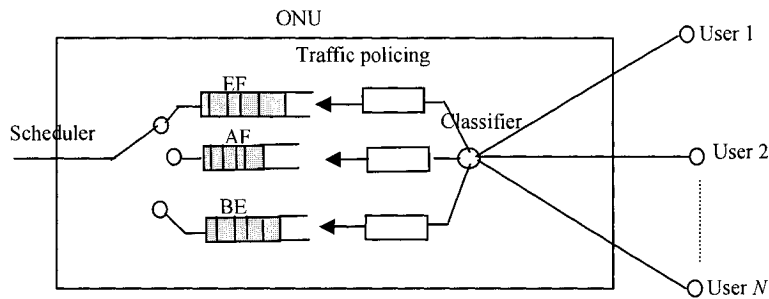
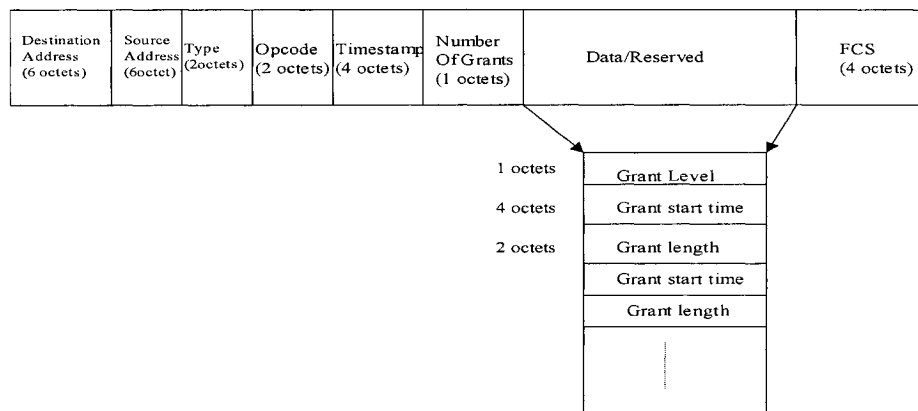

**Figure 3.5 Priority queuing**

### 3.4.2 Packet Scheduling

To transmit the packets buffered in the queue, a priority queue scheduler must be employed for scheduling packet transmissions. *Specifically*, to meet the QoS requirements of different service classes, scheduling should include the arbitration of the packet transmission from not only different ONUs but also different priority queues in each ONU. Accordingly, there are two types of scheduling: inter-ONU scheduling and intra-ONU scheduling. In inter-ONU scheduling, the OLT is responsible for arbitrating the transmission from different ONUs; while in intra-ONU scheduling, each ONU is responsible for arbitrating the transmission from different priority queues at the ONU itself.

In general, there are two possible strategies to carry out packet scheduling. One strategy is to let the OLT to control both inter-ONU scheduling and intra-ONU scheduling. In this case, the OLT is the central controller that schedules the upstream transmission. Each ONU can request the OLT to allocate bandwidth for each traffic class. For this purpose, an ONU has to report the status of its individual priority queues to the OLT, which can be implemented through the use of REPORT message. MPCP specifies that each ONU can report the status of up to eight priority queues [IEEE802B]. The OLT then can generate multiple grants, each for a specific traffic class, to be sent to the ONU using a single GATE message. Each GATE message might carry one or more grant messages. The 64-byte MPCP GATE message is illustrated in Figure 3.6.



**Figure 3.6 MPCP GATE message format**

The other strategy to perform the scheduling is to allow the OLT to perform inter-ONU scheduling whereas to allow each ONU to perform intra-ONU scheduling. In this case, each ONU sends a REPORT message to the OLT to

request bandwidth based on its buffer occupancy status. The OLT only needs to allocate a total bandwidth based on each ONU's total requested bandwidth. Each ONU will in turn divide the allocated bandwidth among different classes based on their QoS requirements and schedule the transmission of different priority queues with the allocated bandwidth.

In general, both scheduling strategies have advantages and disadvantages. Allowing the OLT to perform scheduling has mainly three benefits: First, it is to relieve the maintenance of ONU because the ONU becomes very simple equipment and is usually located at the customer premise. Second, it is more flexible to upgrade or add new ONUs. Various scheduling algorithms can be deployed at the OLT without any modifications at the subscriber side. Hence, SLA can be changed and modified at any time. Third, better network performance may be achieved, in particular, increased network throughput. This issue is further addressed through simulation in Chapter 5. However, removing the scheduling mechanism from ONUs to the OLT also has disadvantages: this comes at the penalty of increased grant size to carry multiple grant information for each of those possible service classes. Further, the OLT will have an increased calculation burden to perform scheduling for all those ONUs.

In packet scheduling, there are two types of scheduling algorithms: strict priority scheduling (defined in P802.1D, clause 7.7.4) and non-strict priority scheduling. In strict scheduling, a lower priority queue is scheduled only if all

higher priority queues are empty. This situation will result in infinity packet delay and high packet loss for lower priority traffic. This will also increase the degree of unfairness. The operation of such scheduler is illustrated by a simple example shown in Figure 3.7[ASSI03], where only one ONU is considered. Assume that at time  $t_{n-1}$ , the ONU sends a REPORT message to the OLT to request bandwidth based on its current buffer occupancy. Upon receiving the REPORT message, the OLT allocates the requested bandwidth to the ONU by sending a GATE message.

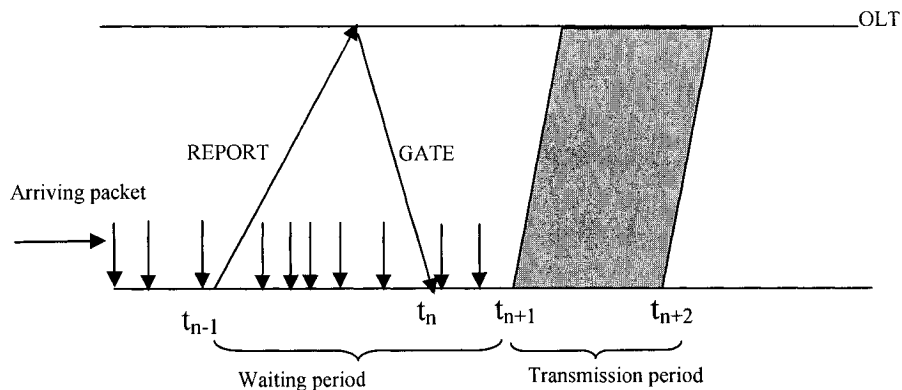

**Figure 3.7 an example of illustrating packet Scheduling**

This GATE message arrives at the ONU at time  $t_n$ , and the transmission time of ONU is scheduled at later time  $t_{n+1}$ . Now the time interval  $(t_{n+1} - t_{n-1})$  is the waiting time, during which more packets may arrive into the buffer and contend for the upstream transmission. With strict priority scheduling, the high priority traffic arriving during this period (waiting time) will be scheduled before the reported low priority traffic. This will result in the transmission of low priority traffic being delayed for one or more cycles, increasing infinitely queuing delay and prohibiting them from being transmitted in their allocated transmission window as specified by

the bandwidth allocation algorithm. To address this problem, a non-strict priority scheduling was proposed in [ASSI03], in which only those reported packets are given high priority as well as time-slots for transmission. The transmission order of different priority queues is based on their priorities, i.e. round robin service discipline. If packets arriving before  $t_n$  are all scheduled, and the current time-slot still can accommodate more traffic, it will allow the transmission for packets arriving during the waiting period ( $t_{n+1} - t_{n-1}$ ) based on their priorities. In this way, all traffic classes can have access to the upstream channel within the allocated time-slot as reported to the OLT, while their priorities are still maintained, and thus ensure fairness in scheduling packets.

In summary, the PSDBA-based scheme can use either the strategy of allowing the OLT to perform inter-ONU and intra-ONU scheduling or allowing the OLT to perform inter-ONU scheduling while letting each ONU to perform intra-ONU scheduling. In packet scheduling, the non-strict priority scheduling is used to schedule upstream packet transmission.

### **3.5 The PSDBA Algorithm**

As for EPON, a highly efficient bandwidth allocation algorithm with QoS support plays a very important role. In EPON, the overall goal of bandwidth allocation is to effectively and efficiently perform fair scheduling of time-slots among ONUs. It is already known that MPCP provides an effective control mechanism to support dynamic bandwidth allocation. However, it does not specify or require any specific

bandwidth allocation algorithm and allows it to be vendors-specific. With MPCP, each ONU periodically reports its buffer occupancy status to the OLT and requests its desired bandwidth. Upon receiving the REPORT message from an ONU, the OLT passes this information to the DBA module at the MAC client layer. The DBA module then calculates bandwidth allocation and generates grant messages. Note that each GATE may carry multiple grants messages to support differentiated QoS.

The PSDBA algorithm works on a per-slot basis, which means that the OLT allocates excess bandwidth resulted from those lightly-loaded ONUs fairly to those heavily-loaded ONUs upon the receipt of each ONU's REPORT message. Here, the network model is described as in Section 3.2, where an EPON access network has  $N$  ONUs. The transmission rate between the OLT and ONUs is  $R_N$  Mbit/s.  $B_i^{\min}$  is defined as the minimum guaranteed bandwidth for ONU  $i$ ,  $0 \leq i \leq N-1$ , which is the guaranteed bandwidth under heavy load condition.  $B_i^{\min}$  is determined as follows:

$$B_i^{\min} = \frac{(T_{cycle} - N \times T_g) \times R_N \times w_i}{8} \quad (3-1)$$

In equation (3-1),  $T_{cycle}$  is the granted cycle time that is the time during which all ONUs have chances to transmit data and report to the OLT,  $T_g$  is the guard time that is used to separate the time-slot allocated to different ONUs, and

$w_i$  is the weight assigned to each ONU based on its SLA.  $T_{cycle}$  is an important parameter for EPON. If it is set too large, it will result in increased average delay for all Ethernet packets. The reason is that a larger cycle time leads to a larger assigned transmission window size. While one ONU is occupying the transmission channel, the traffic waiting in the next ONU will experience increased delay. On the other hand, if  $T_{cycle}$  is set too small, it will result in more bandwidth being wasted due to the guard interval  $T_g$  that is necessary to separate transmission for any two consecutive ONUs. Setting the  $T_{cycle}$  too small also leads to increased CPU processing load and potentially prevents packets from being transmitted because no packet fragmentation is allowed. Note that, in equation (3-1), if all ONUs were not to be classified based on their SLA, i.e.,  $w_i = 1/N, \forall_i$ , and  $\sum_{i=1}^N w_i = 1$ , then the minimum guaranteed bandwidth for each ONU will be the value determined as follows:

$$B_i^{\min} = \frac{(T_{cycle} - N \times T_g) \times R_N}{8 \times N} \quad (3-2)$$

To dynamically allocate bandwidth to each ONU based on its instant bandwidth demand, several approaches have been proposed. Before proceeding further, one important concept is the *excess bandwidth*, which is due to the fact of the burst nature of Ethernet traffic, some ONUs may have traffic  $\leq B_i^{\min}$  to transmit while other ONUs may have traffic  $> B_i^{\min}$  to transmit. The total resulted excessive

bandwidth is denoted by  $B_{total}^{excess}$ . Now, let  $R_i$  be the requested bandwidth for ONU $_i$  and  $B_i^{grant}$  be the granted bandwidth for ONU $_i$ .

The algorithm in [ASSI03] is to dynamically allocate bandwidth to ONU $s$  by utilizing the total excessive bandwidth, which is calculated as follows:

$$B_{total}^{excess} = \sum_{i \in M} (B_i^{\min} - R_i) \quad (3-3)$$

where  $M$  is the set of lightly-loaded ONU $s$  in the *current* frame such that for each ONU  $i \in M$ , we have  $B_i^{\min} > R_i$ . This algorithm is described as follows:

$$B_i^{grant} = \begin{cases} R_i, & \text{if } R_i < B_i^{\min} \\ B_i^{\min} + B_i^{excess}, & \text{if } R_i \geq B_i^{\min} \end{cases} \quad (3-4)$$

where  $B_i^{excess}$  is the excessive bandwidth allocated to ONU $_i$ , which can be derived from equation (3-5): each ONU gets the excessive bandwidth in proportional to its requested bandwidth.

$$B_i^{excess} = \frac{B_{total}^{excess} \times R_i}{\sum_{l \in L} R_l} \quad (3-5)$$

where  $L$  is the set of heavily-loaded ONU $s$  such that each ONU  $i \in L$ , we have  $R_i > B_i^{\min}$ . In this scheme, an early allocation mechanism is deployed in which an ONU requested bandwidth  $R_i < B_i^{\min}$  could be scheduled instantaneously without

waiting. Whereas, those who are requesting bandwidth  $R_i > B_i^{\min}$  will have to wait until all REPORT messages have been received by the OLT and the DBA algorithm can then compute their bandwidth allocation. This has been shown as in Figure 3.2. In this way, the inter-frame idle time can be reduced, especially under light load. However, under heavy load this inter-frame idle time cannot be significantly reduced as compared with its original version. As a result, such per-frame bandwidth allocation algorithm will result in bandwidth being wasted due to the large idle time between consecutive frames. On the contrary, the PSDBA algorithm can completely eliminate the inter-frame idle time and maximize the channel utilization. The PSDBA algorithm is described as following:

$$B_i^{grant} = \begin{cases} R_i, & \text{if } R_i < B_i^{\min} \\ R_i, & \text{if } R_i > B_i^{\min} \text{ and } (R_i - B_i^{\min}) < B_i^{excess} \\ B_i^{\min} + B_i^{excess}, & \text{if } R_i > B_i^{\min} \text{ and } (R_i - B_i^{\min}) > B_i^{excess} \end{cases} \quad (3-6)$$

Here, equation (3-5) is used to calculate the excessive bandwidth,  $B_i^{excess}$  allocated to ONU $i$ . However, the *method* and the *time* we use to calculate the total excess bandwidth  $B_{total}^{excess}$ , which is distributed among heavily-loaded ONUs, is different as shown below:

$$B_{total}^{excess} = \sum_{i \in A} (B_i^{\min} - R_i), \forall i, R_i < B_i^{\min} \quad (3-7)$$

Where,  $A$  represents a list stored at the OLT. It contains  $N$  items and records the most recent requested bandwidth information that OLT has received from each ONU. Consider  $ONU_i$  as the current ONU being granted, information in this list used for bandwidth allocation is the items from  $ONU_{i+1}$  to the ONU whose request has been last received at the OLT. Note that this list is updated upon the OLT receiving a new request from an ONU.

Figure 3.8 illustrates how the PSDBA algorithm works. The operation of this algorithm is illustrated via a simple example. Assume that the OLT receives the REPORT message from  $ONU_3$  at time  $t_1$  in the current frame. Here, it is also assumed that the requested bandwidth of  $ONU_3$  is larger than its minimum guaranteed bandwidth  $B_3^{\min}$ . To ease the analysis here, the processing time for GATE message and REPORT message are ignored to avoid confusion. To better utilize the excess bandwidth, the OLT sends the GATE message to  $ONU_3$  at time  $t_2$ . To achieve maximum upstream utilization,  $t_2$  is calculated by the data transmission ending time of  $ONU_2$  in the next frame minus a downstream propagation delay. In other words, the time  $t_2$  can be considered as the latest time for the OLT to send the GATE message to  $ONU_3$  without causing bandwidth waste. Note that in this example, the OLT would not send the GATE message to  $ONU_3$  at time  $t_1$ . This is because during the time period  $(t_2 - t_1)$ , there are more REPORT messages arriving at the OLT. Among those messages, there may be more excess bandwidth available to contribute to allocate the bandwidth to  $ONU_3$  in the next frame. On the other hand, it does not make any sense for  $ONU_3$  to receive the GATE message

earlier than the time  $t_2$  because the upstream channel is still occupied by other ONUs.

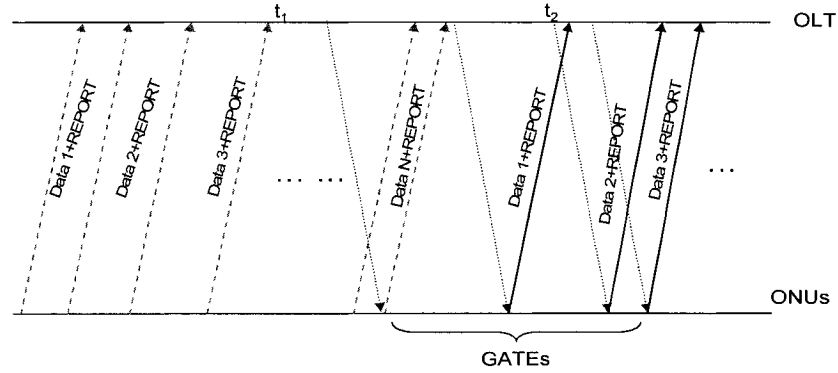

Figure 3.8 illustration of per-slot bandwidth allocation scheme. There are in total  $N$  ONUs.

### 3.6 Bandwidth Allocation with QoS Support

In this section, the PSDBA algorithm is further enhanced to support differentiated QoS. When providing various services to different traffic classes with different requirements, the requested bandwidth  $R_i$  consists of three parts: high-priority ( $H_i$ ), medium-priority ( $M_i$ ), and low-priority ( $L_i$ ). The ONU can have the option to request the OLT to assign bandwidth within the allocated time-slot for each class. In this case, the requested bandwidth  $R_i$  including the three parts demand information is conveyed via a REPORT message to the OLT:

$$R_i = H_i + M_i + L_i \tag{3-8}$$

It is mentioned that MPCP specifies that each ONU can report up to eight queues, and the queues and their orders are also specified in [IEEE802B]. Note that if an ONU prefers shifting the complexity of the queue management to the OLT, which performs intra-ONU scheduling, the OLT then can generate multiple grants, each for specific class. The multiple grants will be transmitted using a single GATE message:

$$B_i^{grant} = H_i^{grant} + M_i^{grant} + L_i^{grant} \quad (3-9)$$

where  $H_i^{grant}$ ,  $M_i^{grant}$ ,  $L_i^{grant}$  are the bandwidth granted to the three traffic classes, respectively. As shown in Figure 3.8, this grant information is carried by a single GATE message in the designated DATA/RESERVED field (39 octets); each grant consists of a grant “start time” and a “grant length” (total of 6 octets), therefore, total of six grants (36 octets) can be carried by a GATE message. In addition, the OLT includes an additional one byte of data “grant level” to identify the order of the queues to which grants are generated. In this way, when the GATE message arrives to an ONU, the ONU is able to classify grants to their particular queues. For example: in an EPON system with eight queues for each ONU, 10110000 indicate that three priority queues have been assigned grants and their grant information (start time and length) follows the same order.

### 3.7 Summary

In this chapter, the PSDBA-based scheme has been introduced in detail. It has the following characteristics:

First, the scheduling of its grant transmission works in a way such that a grant to ONU $i$  for its next transmission should be scheduled to reach ONU $i$  right before the data transmission ending time of ONU $_{i-1}$ . This scheduling strategy maximizes the upstream channel utilization and leads to the “nearly-seamless” transmission of ONUs. The idle time between consecutive frames is completely eliminated, and thus the average packet delay is decreased and the system throughput is increased.

Second, the OLT maintains a list of items, which contains the information on the bandwidth requirements of all ONUs. But only the information received from *next* to current ONU up to  $N-1$  items of most *recent* requests that the OLT received can be used in calculating the total excess bandwidth  $B_{total}^{excess}$ . In this way, the freshness of data in bandwidth calculation is maintained. Here,  $N$  denotes the number of ONUs in the system.

Third, in this PSDBA algorithm, the order of data transmission from different ONUs is always maintained. This can help to smooth out the jitter in transmission.

In the next chapter, simulation is used to verify the high performance of the PSDBA algorithm regarding how it removes the channel idle time and increases the system throughput.

# **Chapter 4      PERFORMANCE      EVALUATION AND SIMULATION RESULTS**

## **4.1 Introduction**

To evaluate the network performance of the proposed bandwidth allocation algorithm, the PSDBA algorithm is compared with the per-frame based algorithm [ASSI03]. For this purpose, an event-driven EPON simulator is developed in Java language. In the following sections, a detailed description of the simulation model is first introduced. Then the simulation results are described. Finally, the performance evaluation based on the simulation results is provided.

## **4.2 Simulation Model**

### **4.2.1 Assumptions**

In the simulation, an EPON access network with 16 ONUs connected in tree topology is considered, as shown in Figure 3.3. The distance between the OLT and the ONU is 25 KM. The link capacity  $R_N$  between the OLT and ONUs is considered to be 1Gb/s and the data rate  $R_u$  from users to an ONU is considered to be 100Mb/s.

Here, it is assumed that the channel capacity is the same in upstream and downstream direction. Each ONU can support three priority queues, sharing the same buffering space of size  $Q$ , which is set to 10Mb. The maximum cycle time is set to 2 ms. The guard time  $T_g$  between transmission from different ONUs is set to 5  $\mu$ s and the value of Inter-Frame Gap (IFG) between Ethernet packets is 96 bits.

In the simulation, the traffic is assumed to be Poisson distributed. For the traffic profile in the case of QoS support, 20 percent of the network load is set for EF, and the rest is equally divided between AF and BE, i.e. 40 percent each. The packet size of the AF and BE traffic is uniformly distributed between 64-1518 bytes. For the EF traffic, the packet size is set to 70 bytes. When the traffic is generated to an ONU, the frames should be buffered in the corresponding queue in the ONU until the ONU is allowed to transmit the frames.

### **4.2.2 Metrics**

In order to evaluate the network performance of the PSDBA algorithm, several metrics are required. The metrics used in the simulation include average packet delay, maximum packet delay, system throughput, and average queue length, and average packet loss.

The average packet delay ( $AD$ ) is the average time between the instant a packet arrives in an ONU and the instant the packet arrives at the OLT. It is defined as follows:

$$AD = \frac{\sum_{x=1}^s D_x}{s} + T_{pro} + T_x \quad (4-1)$$

where  $D_x$  is the delay of the  $x$ th packet sent,  $T_{pro}$  is the upstream propagation delay,  $T_x$  is the transmission time for the  $x$ th packet sent and  $s$  is the total number of packets sent.

The maximum packet delay ( $MD$ ) is the maximum time between the instant a packet arrives in an ONU and the instant the packet arrives at the OLT. It can be defined as:

$$MD = \max\{D_x | x = 1, s\} \quad (4-2)$$

The system throughput ( $\alpha$ ) is the total number of packets sent to the OLT per second and is defined as:

$$\alpha = \frac{\text{Total number of packets sent}}{\text{Total packets sending time}} \quad (4-3)$$

The average queue length ( $AL$ ) is the average number of packets waiting in the queue for all ONUs. It is defined as:

$$AL = \frac{\sum_{k=1}^m \sum_{i=0}^{n-1} L_i^k}{m \times n} \quad (4-4)$$

where  $L_i^k$  is the queue length at the instant that the  $k$ th packet arrives at the  $ONU_i$ ;  $m$  is the total number of packets arrived and  $n$  is the number of ONUs.

The average packet loss ( $\beta$ ) is the average number of packets lost in the system and is defined as:

$$\beta = \frac{\text{Total number of packets lost}}{\text{number of ONUs}} \quad (4-5)$$

### 4.2.3 Simulation Flowcharts

In the discrete-event simulator, we define five different events, i.e., the packet arrival event (packetArrival), the data transmission event (dataTrans), the request arrival event (requestArrival), the grant transmit event (grantTrans) and the grant arrival event (grantArrival). The flowcharts of the request arrival event, the grant transmit event and the data transmission event are presented. Here, to ease the explanation, the flowcharts of the basic operations without considering differentiated services are given.

The flowchart of grantTrans event is shown in Figure 4.1.

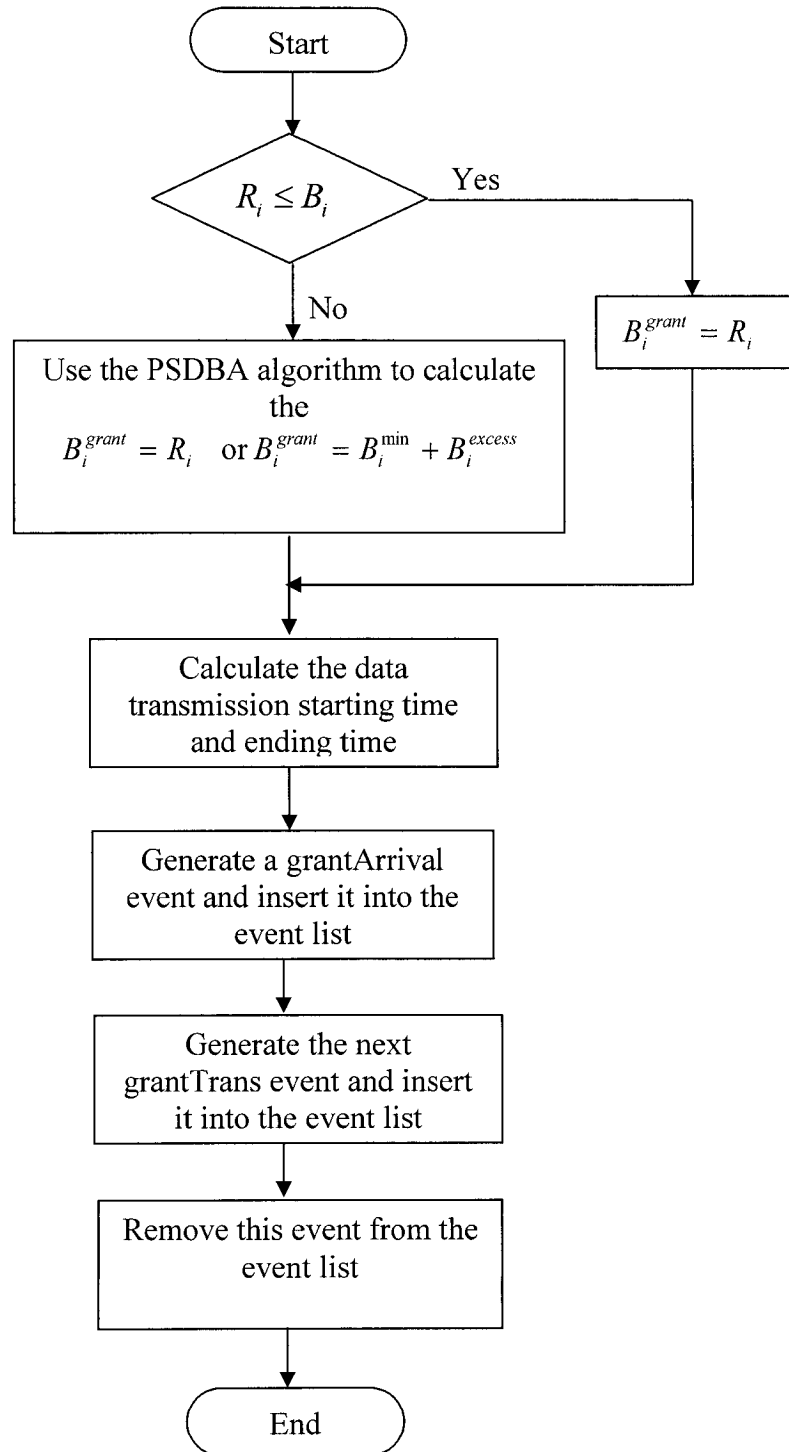

Figure 4.1 Flowchart of grantTrans

The flowchart of dataTrans event is shown in Figure 4.2.

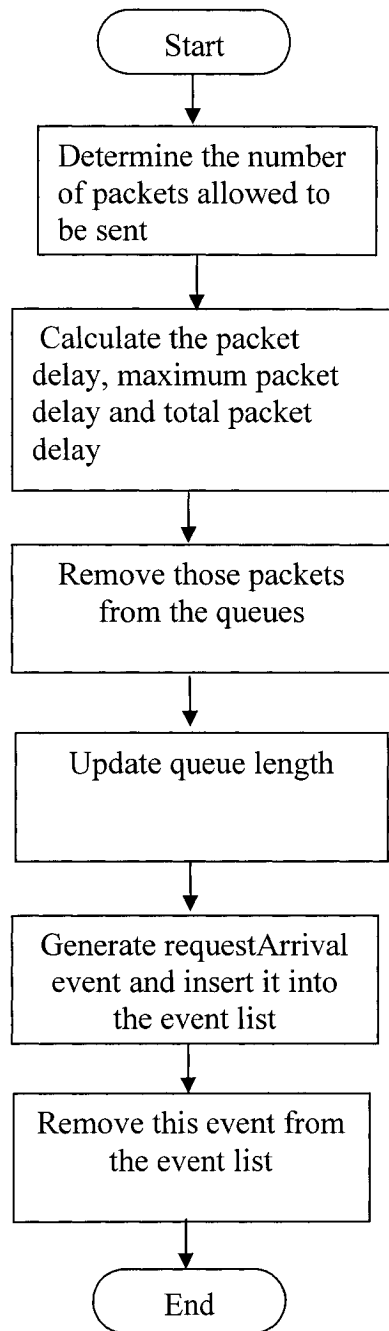

Figure 4.2 Flowchart of dataTrans event

The flowchart of requestArrival event is shown in Figure 4.3.

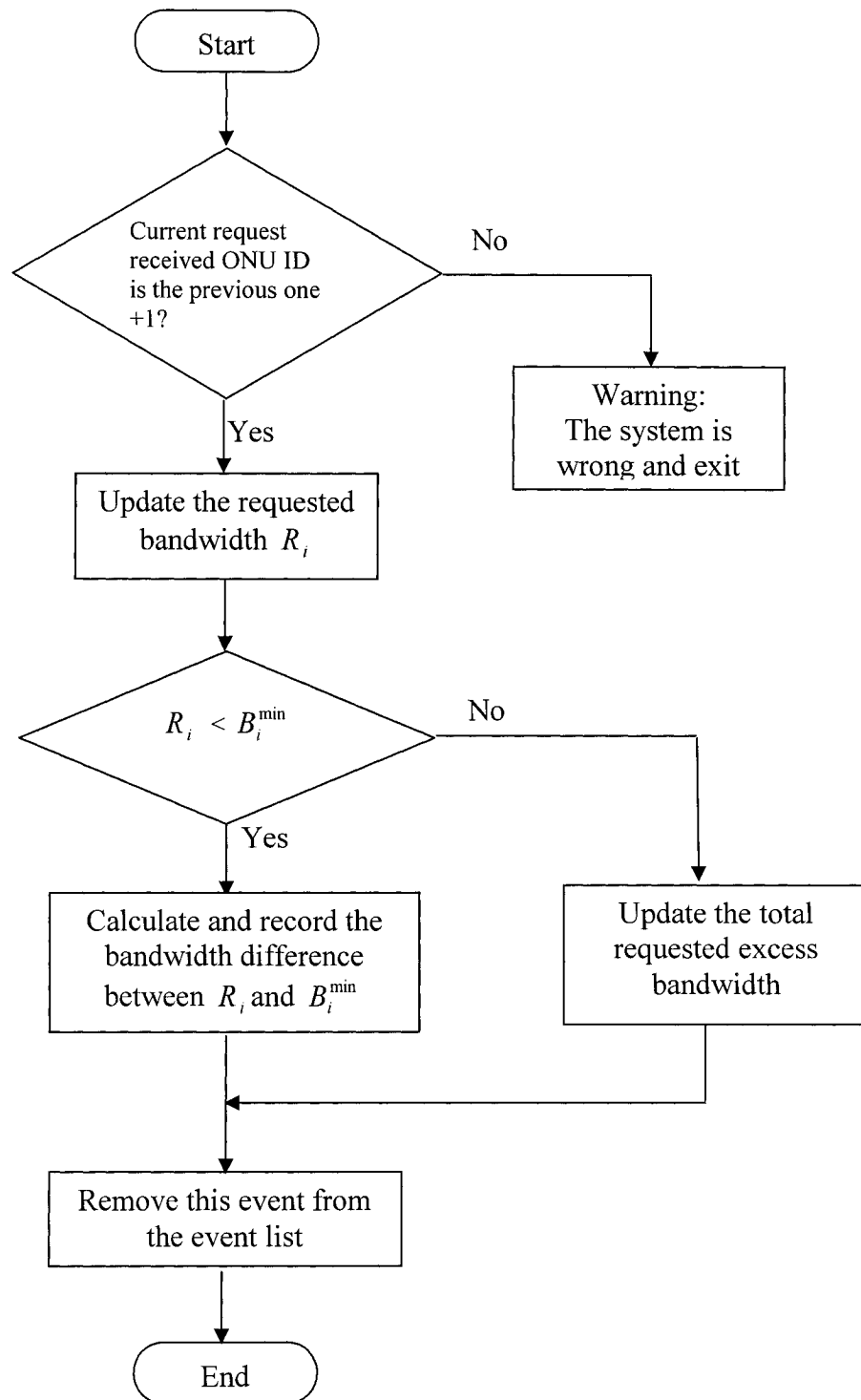

Figure 4.3 Flowchart of requestArrival

The flowchart of main function is shown in Figure 4.4.

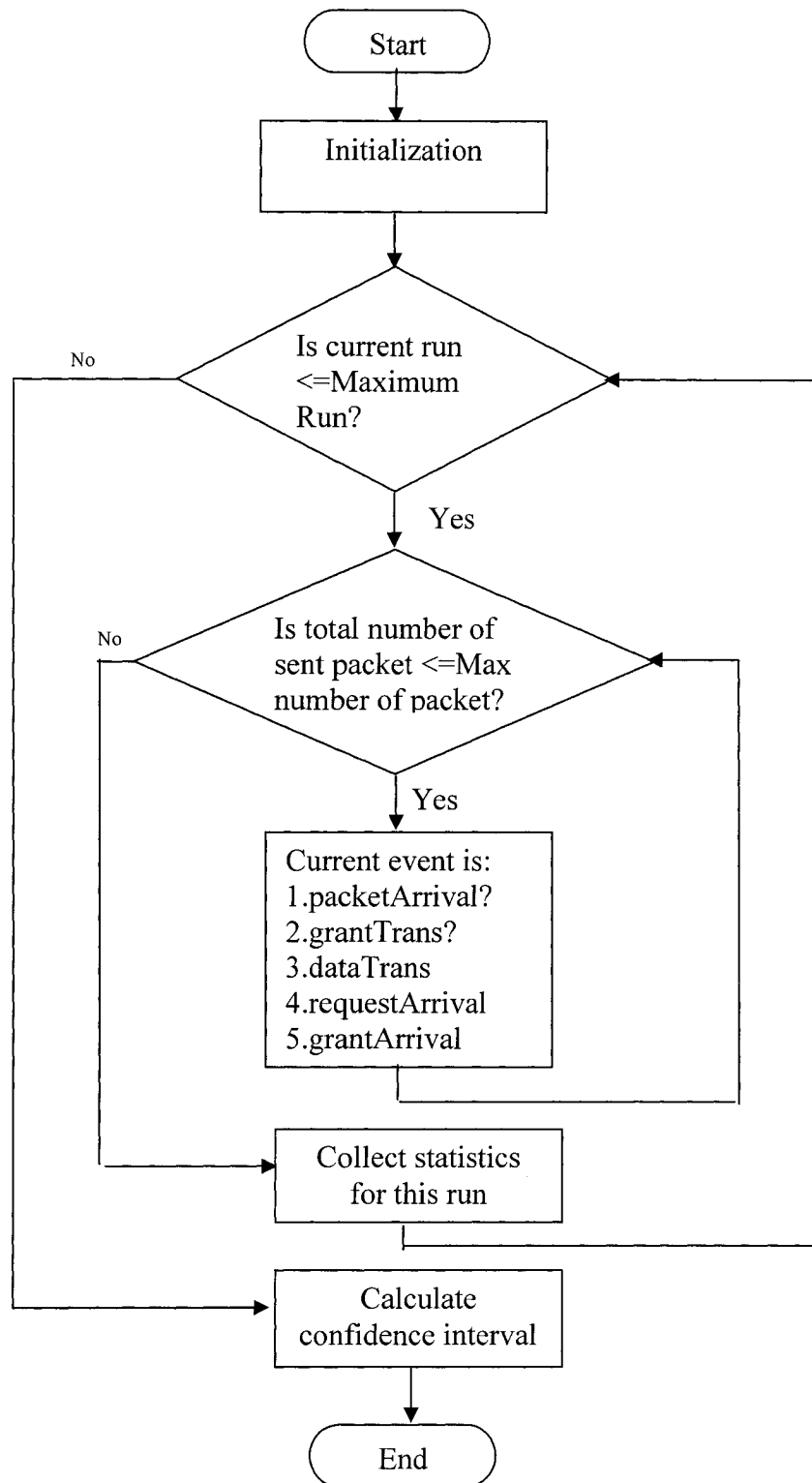

Figure 4.4 Flowchart of main function

## 4.3 Simulation Results

In this section, the simulation results for traffic with and without QoS requirements are presented and analyzed.

### 4.3.1 DBA without QoS Support

The PSDBA algorithm is first compared with the DBA algorithm proposed in [ASSI03](called hereafter DBA-frame algorithm) without considering differentiated services for the incoming traffic. As discussed earlier, the PSDBA algorithm works on a per-slot basis and the DBA-frame algorithm works on a per-frame basis. Because in [ASSI03], the authors have compared the performance of DBA-frame with the fixed bandwidth allocation algorithm (FBA), and the results there show that the performance of DBA-frame significantly outperforms FBA. So the FBA here is not simulated and only the PSDBA algorithm is compared with the DBA-frame algorithm in which early allocation mechanism is deployed. Figure 4.5 and Figure 4.6 show the results of the average packet delay and the maximum packet delay respectively. From the curves, one can observe that for both algorithms both the average delay and maximum delay increase with the traffic load. However, the PSDBA algorithm has smaller delay than that of the DBA-frame especially under the traffic load  $> 0.8$ . This is due to the fact that in the DBA-frame algorithm, in case of heavy load, if the requested bandwidth from  $ONU_i$  is above the minimum guaranteed bandwidth  $B_i^{\min}$ , the OLT has to wait until all ONUs have transmitted their REPORT messages before it can perform the

bandwidth allocation for ONU $i$ . In contrast, with the PSDBA algorithm, the OLT does not have to wait until receiving all ONUs' REPORT messages to allocate bandwidth to each ONU regardless its requested bandwidth. As a result, the PSDBA algorithm has better network performance in terms of the average packet delay and maximum delay. Note that we only give simulation results under the traffic load of 0.5 to 1.3. This is because when the traffic load is below 0.5, both algorithms perform well due to the less stressful load situation in this case. For DBA-frame, its good performance under low traffic load is explained as follows. Upon receiving a REPORT message from an ONU, the OLT can *immediately* send out its related GATE message without waiting. In this case, the upstream channel almost has no inter-frame idle time. As a result, all traffic experiences very small average packet delay and maximum delay.

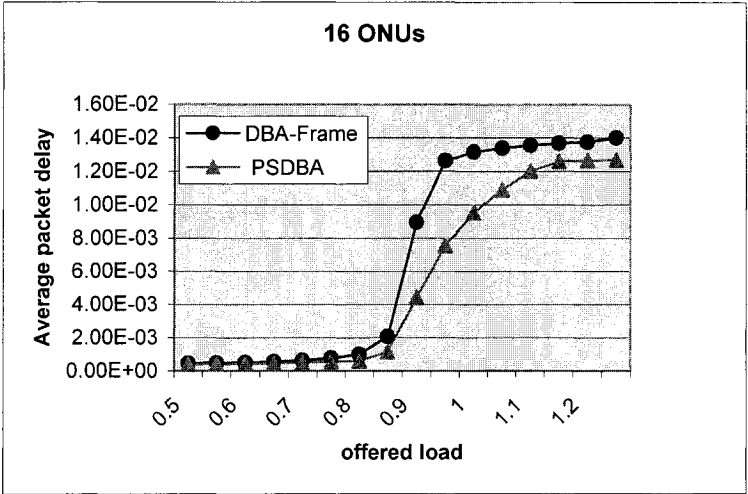

Figure 4.5 Comparison of Average packet delay (AD)

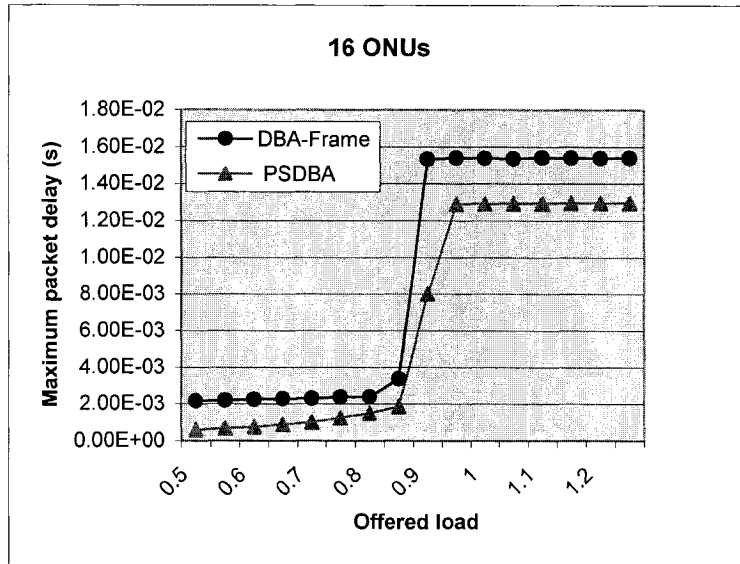

Figure 4.6 Comparison of Maximum Packet Delay (MD)

Figure 4.7 illustrates the throughput performance for both algorithms. As expected, the DBA-frame has an upper throughput of 87 percent whereas the PSDBA can achieve an upper throughput of 96 percent. The reason is that in PSDBA, the inter-frame idle time of the upstream channel, as observed in DBA-frame is avoided. In this way, the upstream channel is maximally utilized. Hence, it achieves better throughput than the DBA-frame.

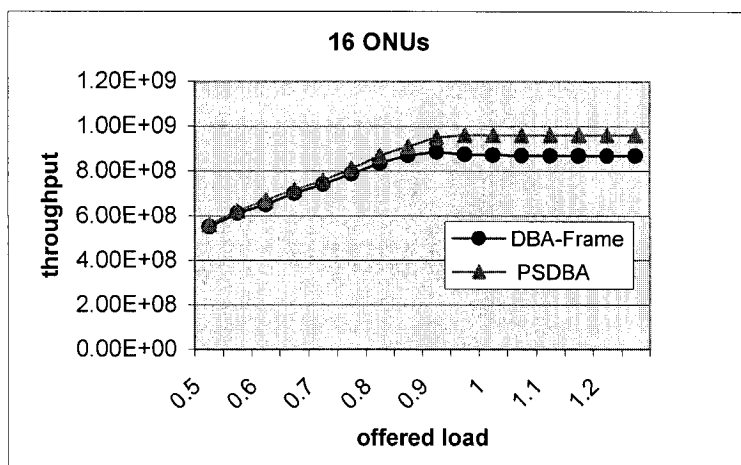

Figure 4.7 Comparison of throughput

In Figure 4.8, the average queue length under both schemes is compared. Due to the fact that the idle time is removed in our proposed algorithm, hence, the waiting time of frames in the queue at ONUs is reduced. As a result, the PSDBA algorithm outperforms the DBA-frame algorithm.

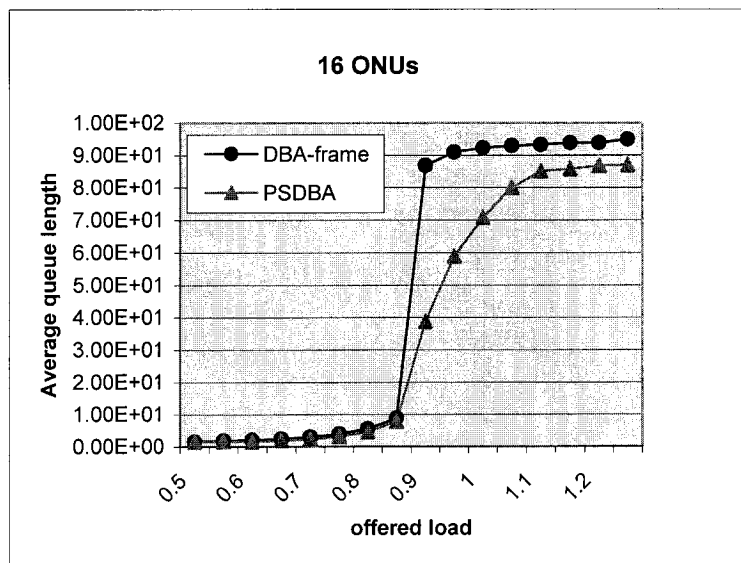

Figure 4.8 Comparison of average queue length

### 4.3.2 DBA with QoS Support

In this section, simulation results are presented to compare the PSDBA with the DBA-frame in providing QoS support. Firstly, we consider the case in which intra-ONU scheduling is performed by each ONU using non-strict priority scheduling.

Figures 4.9(a), 4.9(b), and 4.9(c) show the average packet delay performance for three traffic classes: EF, AF, and BE. From the curves, it is easy to see that for all traffic classes, the average packet delay increases when their load increases. The PSDBA has smaller average packet delay than the DBA-frame especially when the traffic load is above 0.8. This is due to the fact that the PSDBA algorithm completely removes the inter-frame idle time of the upstream channel. While the DBA-frame cannot remove this idle time, which equals to the round trip time plus computation time in the worst case. This phenomenon can occur under heavy load. This is because nearly most ONUs have high bandwidth requirements compared with their minimum guarantee bandwidth. In this case, grants to most ONUs have to be deferred until requests from all ONUs are received. The waiting time of frames in the queue is increased.

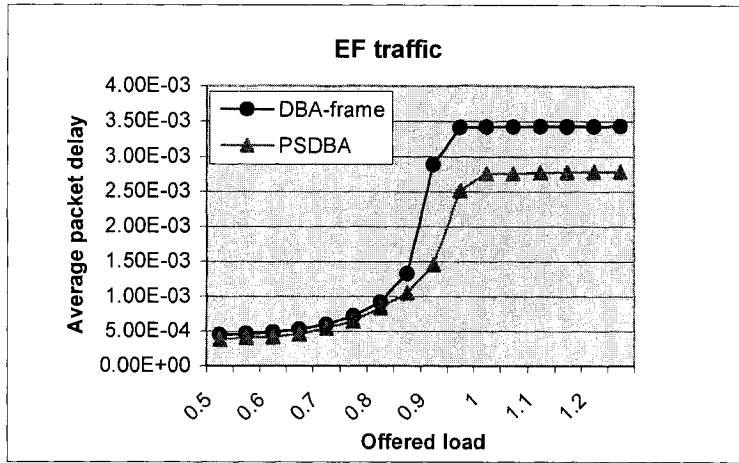

Figure 4.9(a) Comparison of average packet delay for EF traffic

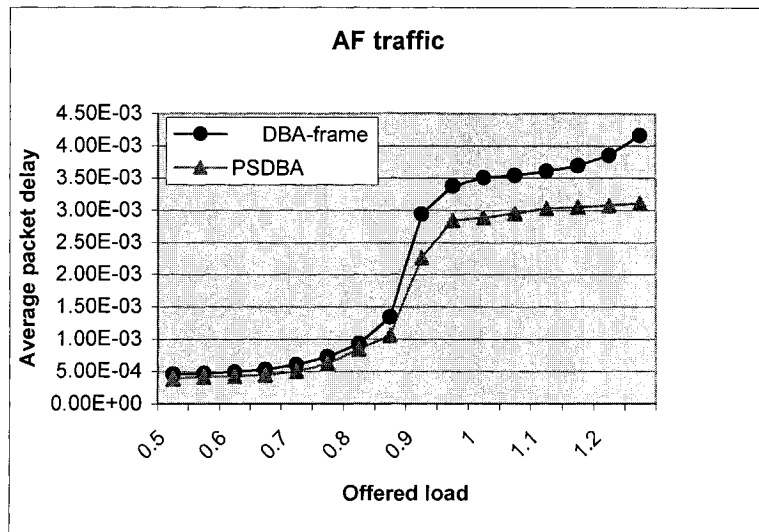

Figure 4.9(b) Comparison of average packet delay for AF traffic

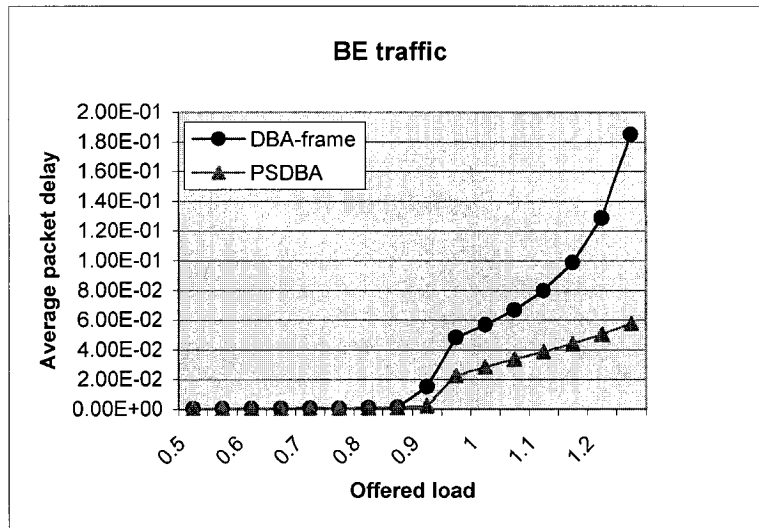

Figure 4.9(c) Comparison of average packet delay for BE traffic

Figures 4.10(a), 4.10(b), and 4.10(c) show the maximum packet delay for EF, AF, and EF traffic respectively. The simulation results reveal that the PSDBA outperforms the DBA-frame. Again, this is due to the elimination of the inter-frame idle time in the PSDBA. In contrast, such idle time still exists in the DBA-frame.

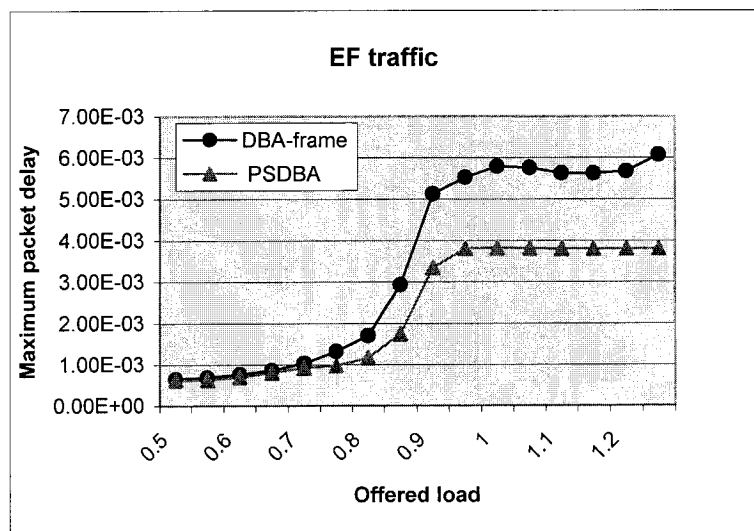

Figure 4.10(a) Comparison of maximum packet delay for EF traffic

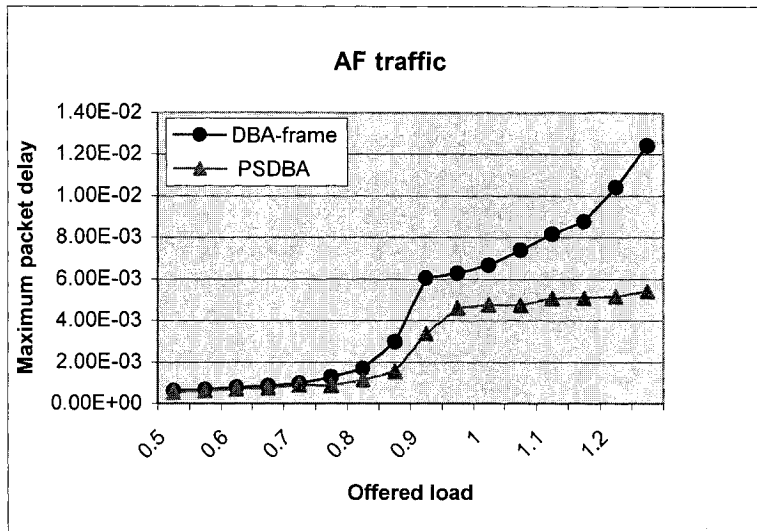

Figure 4.10(b) Comparison of maximum packet delay for AF traffic

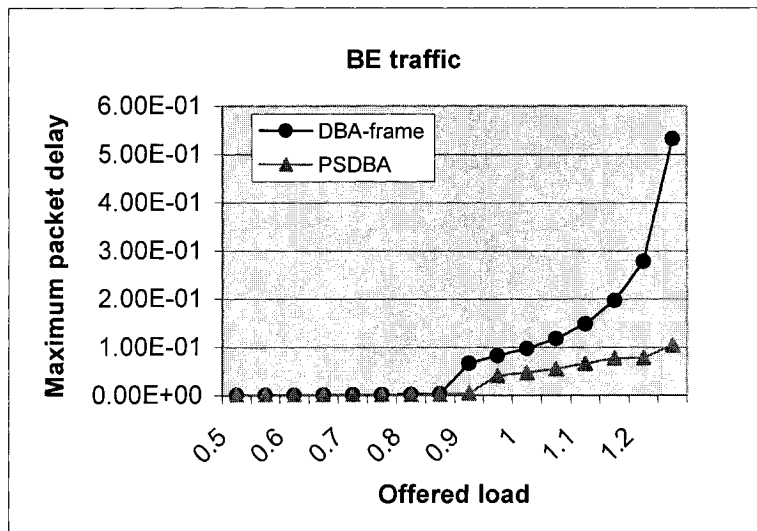
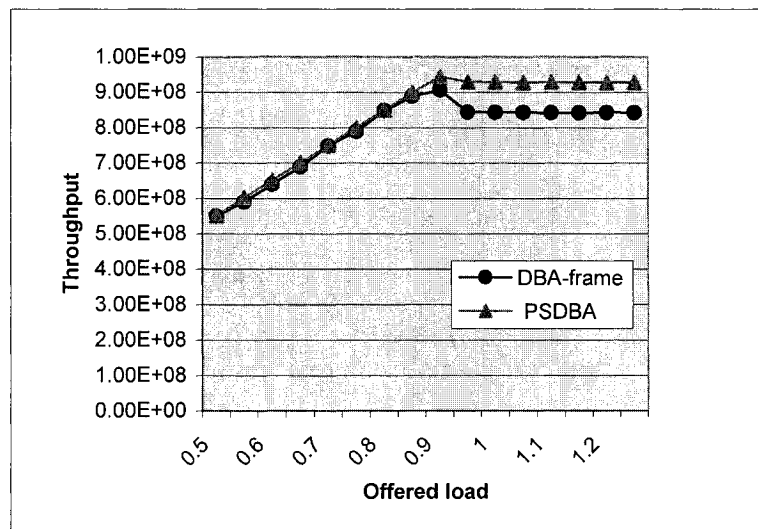

Figure 4.10(c) Comparison of maximum packet delay for BE traffic

Figure 4.11 shows the throughput for the PSDBA compared to that of the DBA-frame. It is easy to see that the PSDBA achieves larger throughput than the DBA-frame due to the removal of the idle time in the PSDBA algorithm. This idle time wastes bandwidth and reduces the channel utilization in the upstream direction. It is also notable that for both DBA-slot and DBA-frame, the throughput increases when the offered load increases; however, it reaches its upper limit where the offered load is at 0.95. The system throughput can never reach 100 percent because some necessary control overheads consume bandwidth, thus reduce the channel utilization.



**Figure 4.11 Comparison of throughput -intra-ONU by ONUs**

Figures 4.12(a), 4.12(b) and 4.12(c) show the average queue length for EF, AF, and BE respectively. From the curves, one can clearly see that the PSDBA has

shorter average queue length than the DBA-frame for each traffic class. This confirms our expectation. The reason is the same as explained before, i.e. the idle time is removed and the waiting time of packets in ONUs is reduced. Therefore, the average queue lengths in PSDBA are shorter than the ones in DBA-frame. In addition, it is notable that in all three classes, the average queue lengths increase as the load increases.

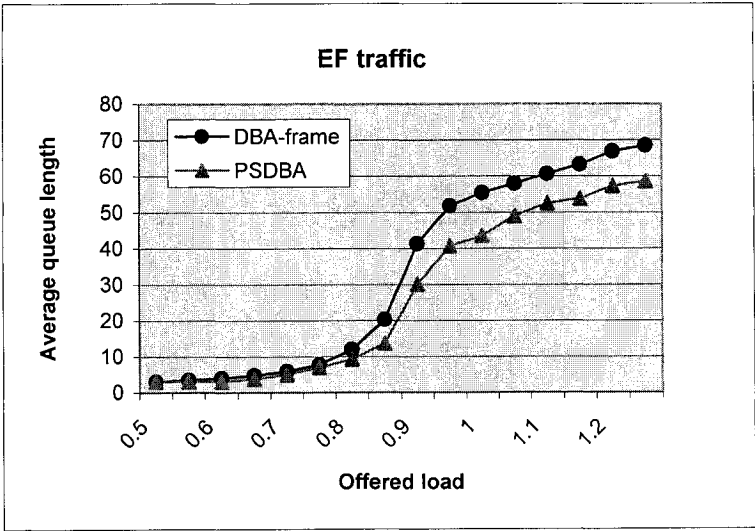

Figure 4.12(a) Comparison of average queue length for EF

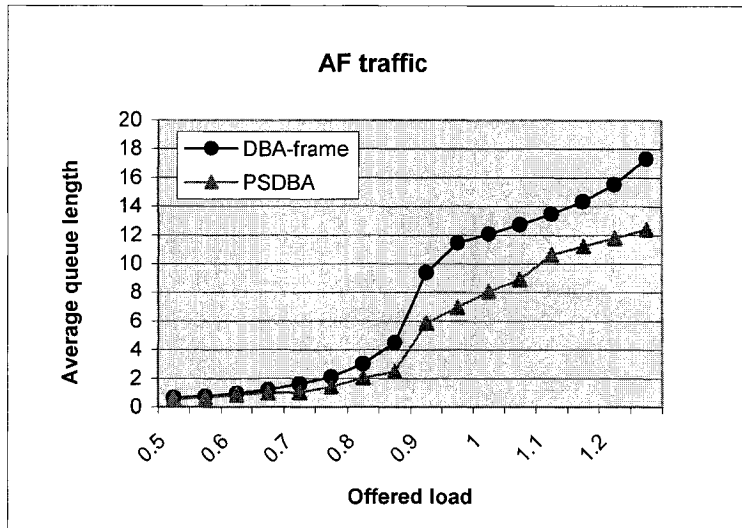

Figure 4.12(b) Comparison of average queue length for AF

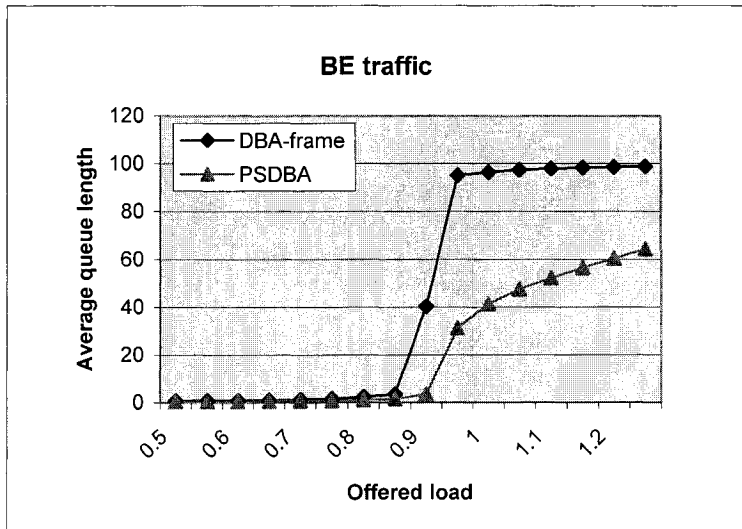

Figure 4.12(c) Comparison of average queue length for BE

The above results are obtained in the case where an ONU performed inter-ONU scheduling. However, one can see that the throughput has a slight decrease under a load over 0.9. This is because the packet size is different for each class. It has been mentioned that in the simulation, the packet size for the EF traffic is assumed to be smaller than the one for the AF and the BE traffic. Under heavy load, if the total requested bandwidth of ONU $i$  is larger than the minimum guaranteed bandwidth  $B_i^{\min}$ , when the OLT receives the GATE message containing this requested bandwidth information, it may only grant the bandwidth as many as the  $B_i^{\min}$ . This may result in some bandwidth being wasted because the packet cannot be fragmented. In particular, when an ONU receives the GATE message from the OLT and performs the packet scheduling, it first assigns the bandwidth to the EF class, and then allocates the bandwidth to the AF class. At last it distributes the remaining bandwidth to the BE class. If the remaining bandwidth does not fit to an integral number of packets, then some bandwidth has to be wasted. This wasted bandwidth becomes large since each ONU can repeat this behaviour. To solve this problem and improve the system throughput, one can choose to let the OLT perform the intra-ONU scheduling. Here, simulations are also performed in which the OLT allocates bandwidth to each class when it has received their individual requested bandwidth from each ONU. Figure 4.13 shows the results.

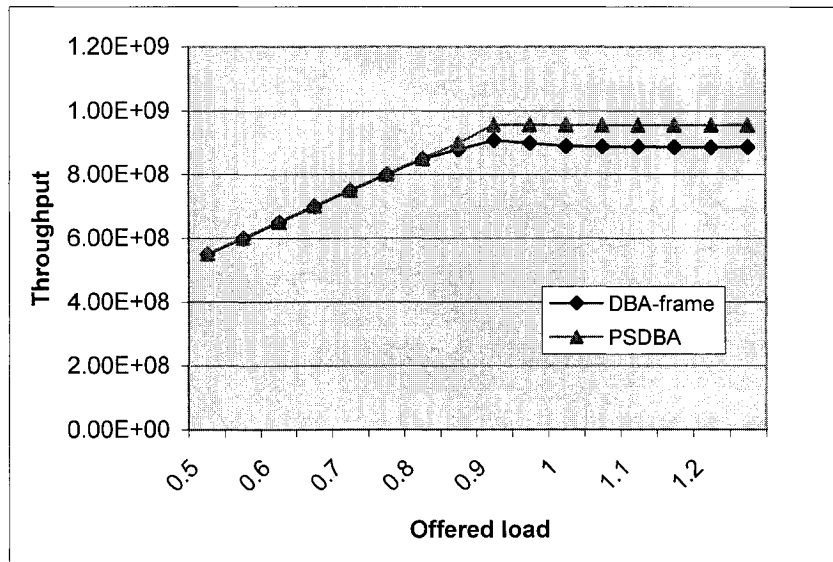

Figure 4.13 Comparison of throughput- intra-ONU by the OLT

#### 4.4 Summary

In this chapter, detailed simulation results are provided to evaluate the performance of the PSDBA algorithm. The PSDBA algorithm is compared with the DBA-frame algorithm with and without considering differentiated services for the incoming traffic. All simulation results indicate that the PSDBA algorithm achieves high performance as expected. Specifically, the simulation results show that the PSDBA algorithm improves the network performance in terms of average packet delay, maximum packet delay, throughput and average queue length.

## **Chapter 5      CONCLUSIONS**

### **5.1   Summary and Concluding Remarks**

EPON has been considered as an attractive solution to the “first mile” bottleneck problem in next-generation broadband access networks. EPON is expected to deliver multi-services and applications with diverse QoS requirements at the access networks [REGE02]. A key issue in designing such networks is to develop efficient bandwidth allocation algorithms. In this thesis, the architectures and characteristics of EOPN have been studied. Some typical bandwidth allocation algorithms in the literature have also been reviewed. To achieve high network performance, a novel DBA algorithm, called PSDBA, working on a per-slot basis to efficiently and fairly allocate bandwidths among end users has been proposed in this thesis. This algorithm has been also extended to support QoS in a differentiated services framework. Specifically, the PSDBA algorithm is integrated with non-strict priority scheduling and priority queuing to implement a cost effective EPON network with QoS support. To evaluate the performance of the PSDBA algorithm, a simulator has been developed and extensive experiments have been carried out to compare the PSDBA algorithm with an existing per-frame-based DBA algorithm.

The simulation results showed the effectiveness of the PSDBA algorithm. In particular, better network performance in terms of average packet delay, maximum packet delay, throughput and average queue length, has been achieved compared with existing work. This is due to the fact that the idle time between any consecutive frames is completely removed. As a result, the network resource is *maximally* utilized, the throughput is *greatly* increased, and the packet delay is *highly* reduced. Moreover, the light-load penalty behaviour is relieved by combining the DBA algorithm with non-strict priority scheduling.

## 5.2 Open Issues

As an extension to this work, the following open issues are suggested for future research.

Bandwidth utilization in EPON is determined by a number of parameters such as cycle time, guard time, propagation delay and packet size. The parameters are set the same as those used in many research studied referenced in the articles [ASSI03][KRAM01][KRAM02A][KRAM02C] [SHER04] [NASE05] [ZHEN05B]. The setting of these parameters has great impacts on the system performance. Optimal tuning of these parameters under different system environments deserves attention for improved bandwidth utilization.

Bandwidth allocation with prediction is another issue of interest. During the waiting period between the time an ONU sends its desired bandwidth and the time it starts to send data, some new packets may arrive at its queue. One method is to defer these packets to the next transmission as it has done in this thesis. Another method currently under great investigation is to allocate bandwidth with prediction. Prediction can be carried out based on historical behavior of traffic from each individual ONU. Allocating bandwidth with prediction can reduce packet delay of each ONU. However, inaccurate prediction can lead to potential bandwidth waste. How to accurately estimate the amount of packets arriving during this waiting period based on traffic characteristics and classes is an interesting point of investigation for future research.

Much work has been carried out in developing efficient scheduling algorithms. Designing scheduling mechanisms to meet different fairness criteria is of a great importance in providing QoS and improved performance in the design of EPON systems. Investigation on this issue is far from being a trivial task and deserves further research.

## REFERENCES

- [AN03] F. An, H. Bae, Y. Hsueh, M. Rogge, L. Kazovsky, and K. Kim, "A new media access control protocol guaranteeing fairness among users in Ethernet-based passive optical networks," Proceedings of IEEE Optical Fiber Communication Conference (OFC'03), vol. 1, pp. 134-135, Mar. 2003.
- [ASSI03] C. Assi, Y. Ye, S. Dixit, and M. A. Ali, "Dynamic bandwidth allocation for quality of service over Ethernet PONs," IEEE Journal on Selected Areas in Communications, vol. 21, issue 9, pp. 1467-1477, Nov. 2003.
- [BANE05A] A. Banerjee, G. Kramer, and B. Mukherjee, "Fair sharing using service-level agreements (SLA) for open access in EPON," Proceedings of IEEE International Communications Conference (ICC'05) Symposium on Optical Networking, Seoul, Korea, vol. 3, pp. 1858 – 1862, May 2005.
- [BANE05B] A. Banerjee, B. Mukherjee, and G. Kramer, "Achieving open access in Ethernet PON (EPON)," Proceedings of IEEE Optical Fiber Communication Conference (OFC'05), vol. 3, pp. 349 – 351, Mar. 2005.

- [BLAK98] S. Blake, D. Black, M. Carlson, E. Davies, Z. Wang, and W. Weiss, "RFC-2475-An Architecture for Differentiated Services," 1998, <http://www.ietf.org/rfc/rfc2475.txt>.
- [BOUI02] E. Bouillet, D. Mitra, and K.G. Ramakrishnan, "The Structure and Management of Service Level Agreements in Networks," IEEE Journal on Selected Areas in Communications, vol. 20, no. 4, pp. 691-699, May 2002.
- [BYUN03] H. J. Byun, J. M. Nho, and J. T. Lim, "Dynamic bandwidth allocation algorithm in Ethernet passive optical networks," Electronics Letters, vol. 39, no. 13, pp. 1001-1002, June 2003.
- [CHAN02] C. Chang-Joon, E. Wong, and R. S. Tucher, "Optical CSMA/CD media access scheme for Ethernet over passive optical network," IEEE Photonics Technology Letters, vol. 14, issue 5, pp. 711-713, May 2002.
- [CHEN05] J. Chen, B. Chen, and S. He, "A novel algorithm for intra-ONU bandwidth allocation in Ethernet passive optical networks," IEEE Communications Letters, vol. 9, issue 9, pp. 850 – 852, Sept. 2005.
- [CHOI02] S. Choi and J. Huh, "Dynamic bandwidth allocation algorithm for multimedia service Ethernet PONs," ETRL Journal, vol. 24, no. 6, pp. 465-468, Dec. 2002.
- [CHOI03] S. Choi, "Cyclic polling-based dynamic bandwidth allocation for differentiated class of service in Ethernet passive optical networks,"

- Kluwer Photonic Network Communications, vol. 7, issue 1, pp. 87-97, Jan. 2004.
- [FOH03] C. H. Foh, L. L. Andrew, M. Zukerman, and E. Wong, "Full-RCMA: a high utilization EPON," Proceedings of IEEE Optical Fiber Communication Conference (OFC'03), Atlanta, GA, vol. 1, pp. 282-284, Mar. 2003.
- [FRAZ01] H. Frazier and G. Pesavento, "Ethernet takes on the first mile," IT professional, vol. 3, issue 4, pp. 17-22, July-August 2001.
- [GESA99] G. Pesavnto, "PONs for the Broadband Local Loop," IEEE Journal of Lightwave Technology, vol. 16, no. 10, pp. 68-74, Sept. 1999.
- [GHAN04] N. Ghani, A. Shami, C. Assi, and M. Y. A. Raja, "Quality of Service in Ethernet Passive Optical Networks," IEEE/Sarnoff Symposium Advances in Wired and Wireless Communication, Princeton, NJ, pp. 161 – 165, Apr. 2004.
- [GRAM01] G. Kramer, B. Mukherjee, and G. Pesavnto, "Ethernet PON (EPON): Design and Analysis of an Optical Access Network," Kluwer Photonic Network Communications, vol. 3, issue 3, pp. 307-319, July 2001.
- [GRAM02] G. Kramer, B. Mukherjee, and A. Maislos, "Ethernet Passive Optical Networks (EPON): a missing link in an end-to-end optical Internet," in "IP over WDM: Building the Next-Generation Optical Internet", edited by S. Dixit, John Wiley & Sons, Inc, Mar. 2003.

- [GUMA03] A. Gumaste and I. Chlamtac, "A Protocol to Implement Ethernet Over PON," Proceedings of IEEE ICC'03 Symposium on Optical Networking, Anchorage, Alaska, vol. 2, issue 11, pp. 1345 – 1349, May 2003.
- [GUMA03] A. Gumaste and I. Chlamtac, "An Efficient Protocol for IP centric Communication using EPON", Proceedings of 7th IFIP Working Conference on Optical Network Design and Modeling (ONDM03), Budapest, Hungary, Feb. 2003.
- [IEEE802A] IEEE 802.3ah task force home page, <http://www.ieee802.org/3/efm>, Sept. 2004.
- [IEEE802B] 802.ah P2MP Track, "MPCP baseline proposal architecture and layering model," IEEE (2004),  
[http://www.ieee802.org/3/efm/baseline/sala\\_1\\_0302.pdf](http://www.ieee802.org/3/efm/baseline/sala_1_0302.pdf).
- [IEEE802C] 802.ah P2MP Track, "MPCP general description," IEEE (2004),  
[http://www.ieee802.org/3/efm/baseline/maislos\\_1\\_0312.pdf](http://www.ieee802.org/3/efm/baseline/maislos_1_0312.pdf).
- [IEEE802D] IEEE 802.3 Ethernet in the First Mile Study Group:  
<http://www.ieee802.org/3/efm/public/index.html>, Sept. 2004.
- [KAMA05] A.E. Kamal and B.F., Blietz, "Priority mechanism for the IEEE 802.3ah EPON," Proceedings of IEEE ICC'05 Symposium on Optical Networking, Seoul, Korea, vol. 3, pp. 1879 – 1883, May 2005.
- [KIM03] K. S. Kim, "On the evolution of PON-based FTTH solution," Information Sciences, vol. 49, no. 1-3, pp. 21-30, Jan. 2003.

- [KRAM05] G. Kramer, "Ethernet Passive Optical Networks," McGraw-Hill Professional, ISBN: 0071445625, May 2005.
- [KRAM04] G. Kramer, A. Banerjee, N. K. Singhal, B. Mukherjee, S. Dixit, and Y. Ye, "Fair queuing with service envelopes (FQSE): a cousin-fair hierarchical scheduler for subscriber access networks," IEEE Journal on Selected Areas in Communications vol. 22, issue 8, pp. 1497 – 1513, Oct. 2004.
- [KRAM03] G. Kramer, B. Mukherjee, and A. Maislos, "IP over WDM," Wiley-Interscience, New York, NY, USA, ISBN: 0-471-21248-2, Jan. 2003.
- [KRAM02A] G. Kramer, B. Mukherjee, and G. Pesavnto, "IPACT: A Dynamic Protocol for Ethernet PON," IEEE Communications Magazine, vol. 4, issue 2, pp. 74-79, Feb. 2002.
- [KRAM02B] G. Kramer and G. Pesavnto, "Ethernet Passive Optical Network (EPON): Building a Next Generation Optical Access Network," IEEE Communications Magazine, vol. 40, no. 2, pp. 66-72, Feb. 2002.
- [KRAM02C] G. Kramer, B. Mukherjee, S. Dixit, Y. Ye, and R. Hirth, "On supporting differentiated classes of service in EPON-based access network," Journal of Optical Networking, vol. 1, pp. 280-298, Aug.-Sept. 2002.
- [KRAM01] G. Kramer and B. Mukherjee, "Ethernet PON: design and analysis of an optical access network," Kluwer Photonic Network Communications, vol. 3, no. 3, pp. 307-319, July 2001.

- [LELA94] W. Leland, M. Taqqu, W. Willinger, and D. Wilson, "On the self-Similar Nature of Ethernet Traffic (Extended Version)," *IEEE/ACM Transactions on Networking*, vol. 2, no. 1, pp. 1-15, Feb. 1994.
- [LUNG99] B. Lung, "PON architecture 'future proofs' FTTH," *IEEE Journal of Lightwave Technology*, vol. 16, no. 10, pp. 104–107, Sept. 1999.
- [LUO05A] Y. Luo and N. Ansari, "Dynamic Upstream Bandwidth Allocation over Ethernet PONs," *Proceedings of IEEE ICC'05 Symposium on Optical Networking*, Seoul, Korea, vol. 3, pp. 1853 – 1857, May 2005.
- [LUO05B] Y. Luo and N. Ansari, "Bandwidth allocation for multiservice access on EPONs," *IEEE Communications Magazine*, vol. 43, issue 2, pp. S16 - S21, Feb. 2005.
- [MA03] M. Ma, Y. Zhu and T. H. Cheng, "A bandwidth guaranteed polling MAC protocol for Ethernet passive optical networks," *Proceedings of IEEE INFOCOM' 03*, San Francisco, CA, vol. 1, pp. 22–31, Mar.–Apr. 2003.
- [MAST05] R. Mastrodonato and G. Paltenghi, "Analysis of a Bandwidth Allocation Protocol for Ethernet Passive Optical Networks (EPONs)," *Proceedings of IEEE International Conference on Transport Optical Networks (ICTON'05)*, Barcelona, Spain, pp. 241-244, July 2005.

- [MCGA04] M. P. McGarry, M. Maier, and M. Reisslein, "Ethernet Pons: A survey of dynamic bandwidth allocation (dba) algorithms," *IEEE Communications Magazine*, vol. 42, no. 8, pp. S8–S15, Aug. 2004.
- [MIYS04] H. Miyshi, T. Inuoe, and K. Yamashita, "QoS-aware Dynamic Bandwidth Allocation Scheme in Gigabit-Ethernet Passive Optical Networks," *Proceedings of IEEE ICC'04 Symposium on Optical Networking*, vol. 1, pp. 90-94, June 2004.
- [NASE05] H. Naser and H. Mouftah, "A Class-of-Service Oriented Packet Scheduling (COPS) Algorithm for EPON-based access networks," *Proceedings of IEEE International Conference on Transport Optical Networks (ICTON'05)*, Barcelona, Spain, pp. 232-236, July 2005.
- [NESA01] B.N. Nesai, N. J. Frigo, A. Smiljanic, K. C. Reichmann, R.P. Iannone, and R.S. Roman, "An optical implementation of a packet-based (Ethernet) MAC in a WDM passive optical overlay," *Proceedings of IEEE Optical Fiber Communication Conference (OFC'01)*, vol. 3, pp. WN5-1-WN5-3, Mar. 2001.
- [NIKO03] D. Nikolova, B. Van Houdt, and C. Blondia, "Dynamic bandwidth allocation algorithm in EPON: a simulation study," *Proceedings of SPIE Opticomm'03*, Dallas, TX, vol. 5285, pp. 369-380, Oct. 2003.
- [NOWA04] D. Nowak, P. Perry, and J. Murphy, "Bandwidth Scheduling Techniques for Differentiated Services Support in Ethernet Passive Optical Networks," *Proceedings of 4th International Symposium on*

Communication Systems, Networks and Digital Signal Processing (CSNDSP), Newcastle, UK, vol. 1, pp. 67-70, July 2004.

- [NOUR05] A. Nouroozifar, H. Mouftah, and H. Naser, "A Novel Differentiated Scheduling Algorithm for EPONs," Proceedings of IEEE International Conference on Transport Optical Networks (ICTON'05), Barcelona, Spain, pp. 237-240, July 2005.
- [NOVA04] D. Nowak, P. Perry, and J. Murphy, "Adaptive Dynamic Bandwidth Allocation Algorithm for Ethernet PONs," Proceedings of 30th European Conference on Optical Communications (ECOC'04), Stockholm, Sweden, vol. 3, pp. 740-741, Sept. 2004.
- [PARK01] Jong-Tae Park, Jong-Wook Baek, and J. Won-Ki Hong, "Management of Service Level Agreements for Multimedia Internet Service Using an Utility Model," IEEE Communications Magazine, vol. 39, issue 5, pp. 100-106, May 2001.
- [PESA99] G. Pesavnto and M. Kelsy, "PONs for the broadband local loop," IEEE Journal of Lightwave Technology, vol. 16, no. 10, pp. 68-74, Sept. 1999.
- [PESA02] G. Pesavento, J. C. Kuo, and T. Koyama, "IEEE access standards, 802.3ah GE-PON status," ITU-T Workshop, IP/Optical, Japan, July 2002.
- [PESA03] G. Pesavento, "Ethernet passive optical (EPON) architecture for broadband access," SPIE Optical Networks Magazine, vol. 4, issue 1, pp. 107-113, Jan. /Feb. 2003.

- [PHIL05] M. Abrams, P. C. Becker, Y. Fujimoto, V. O'Byrne, and D. Piehler, "FTTP Deployments in the United States and Japan-Equipment Choices and Service Provider Imperatives," *IEEE Journal of Lightwave Technology*, vol. 23, no. 1, pp. 236-246, Jan. 2005.
- [QIU02] X. Z. Qiu, J. Vandewege, F. Fredricx, and P. Vetter, "Burst mode transmission in PON access systems," *Proceedings of 7<sup>th</sup> European Conference of Networks Optical Communication (ECNOC'02)*, pp. 127-132, Sept. 2002.
- [REGE02] K. Rege, S. Dravida, S. Nanda, S. Narayan, J. Strombosky, M. Tandon, and Gupta, D, "QoS management in trunk-and-branch switched Ethernet networks," *IEEE Communications Magazine*, vol. 40, issue 12, pp. 30–36, Dec. 2002.
- [SALA01] D. Sala and A. Gummalla, "PON functional requirements: services and performance," *IEEE 802.3ah Meeting in Portland OR*, July 2001.
- [SHAM05] A. Shami, X. Bai, C. Assi, and N. Ghani, "Jitter Performance in Ethernet Passive Optical Networks," *IEEE Journal of Lightwave Technology*, vol. 23, issue 4, pp. 1745-1753, Apr. 2005.
- [SHAM04] A. Shami, X. Bai, C. Assi, and N. Ghani, "Quality of Service in Two-Stage Ethernet Passive Optical Access Networks," *Proceedings of IEEE International Conference on Computer Communications and Networks (ICCCN'04)*, Chicago, US, pp. 352-357, Oct. 2004.

- [SHAN03] T. Shan, "EPON Upstream Multiple Access Scheme," *Electronics Letters*, vol. 39, no. 13, pp. 273-278, June 2003.
- [SHER04] S. R. Sherif, A. Hadjiantonis, and G. Ellinas, "A Novel Decentralized Ethernet-Based PON Access Architecture for Provisioning Differentiated QoS," *IEEE Journal of Lightwave Technology*, vol. 22, no. 11, pp. 2483-2497, Nov. 2004.
- [SHIM02] H. Shimonishi, I. Maki, T. Murase, and M. Murata, "Dynamic fair bandwidth allocation for diffiserv classes," *Proceedings of IEEE ICC'02 Symposium on High-Speed Networks*, vol. 4, pp. 2348-2382, Apr.-May 2002.
- [SHIM05] A. Shami, X. Bai, N. Ghani, C.M. Assi, and H.T. Mouftah, "QoS Control Schemes for Two-Stage Ethernet Passive Optical Access Networks," *IEEE Journal on Selected Areas in Communications*, vol. 23, issue 8, pp. 1467 – 1478, Aug. 2005
- [XION04] H. Xiong and M. Cao, "Broadcast polling-an uplink access scheme for the Ethernet passive optical network," *Journal of Optical Networking*, vol. 3, no. 10, pp. 728-735, Oct. 2004.
- [XIE04] J. Xie, S. Jiang, and Y. Norwegian, "A dynamic bandwidth allocation scheme for differentiated services in EPONs," *IEEE Communications Magazine*, vol. 42, issue 8, pp. S32–S39, Aug. 2004.
- [ZHAN03] L. Zhang, E. A. An, C. H. Youn, H. G. Yeo, and S. Yang, "Dual DEB-GPS scheduler for delay-constraint applications in Ethernet

passive optical networks,” IEICE Transactions on Communications, vol. E86, no. B (5), pp. 1575-1584, May 2003.

[ZHEN05A] J. Zheng and H. Mouftah, “Multiple access control for Ethernet passive optical networks (EPONs): an overview,” IEEE Communications Magazine, vol. 43, issue 2, pp. 145-150, Feb. 2005.

[ZHEN05B] J. Zheng and H. Mouftah, “An Adaptive MAC Polling Protocol for Ethernet Passive Optical Networks (EPONs)”, Proceedings of IEEE ICC’05 Symposium on Optical Networking, Seoul, Korea, vol. 3, pp. 1874 – 1878, May 2005.

[ZHU04] Y. Zhu, M. Ma, and T. H. Cheng, “An efficient multiple access control scheme to support differentiated services in EPONS,” Proceedings of IEEE 12th International Conference on Networks (ICON’04), vol. 1, pp. 147 – 151, Nov. 2004.