



uOttawa

L'Université canadienne
Canada's university

FACULTÉ DES ÉTUDES SUPÉRIEURES
ET POSTDOCTORALES



FACULTY OF GRADUATE AND
POSTDOCTORAL STUDIES

Wilfred Tan Lim

AUTEUR DE LA THÈSE / AUTHOR OF THESIS

Ph.D. (Microbiology and Immunology)

GRADE / DEGREE

Department of Biochemistry, Microbiology and Immunology

FACULTÉ, ÉCOLE, DÉPARTEMENT / FACULTY, SCHOOL, DEPARTMENT

Molecular Mechanisms in the Regulation of B7-1 and B7-2 Co-stimulatory Molecules in Human Monocytic Cells

TITRE DE LA THÈSE / TITLE OF THESIS

Ashok Kumar

DIRECTEUR (DIRECTRICE) DE LA THÈSE / THESIS SUPERVISOR

CO-DIRECTEUR (CO-DIRECTRICE) DE LA THÈSE / THESIS CO-SUPERVISOR

EXAMINATEURS (EXAMINATRICES) DE LA THÈSE / THESIS EXAMINERS

Dragana Jankovic

Kathryn Wright

Lakshmi Krishnan

Lisheng Wang

Gary W. Slater

Le Doyen de la Faculté des études supérieures et postdoctorales / Dean of the Faculty of Graduate and Postdoctoral Studies

**Molecular Mechanisms in the Regulation of B7-1 and B7-2 Co-stimulatory
Molecules in Human Monocytic Cells**

by

Wilfred Tan Lim

A thesis submitted to the Faculty of Graduate Studies in partial fulfillment of the
requirements for the degree of Doctor of Philosophy

Department of Biochemistry, Microbiology, and Immunology, Faculty of Medicine,
University of Ottawa, Ottawa, Ontario, Canada

© Wilfred Tan Lim, 2006



Library and
Archives Canada

Bibliothèque et
Archives Canada

Published Heritage
Branch

Direction du
Patrimoine de l'édition

395 Wellington Street
Ottawa ON K1A 0N4
Canada

395, rue Wellington
Ottawa ON K1A 0N4
Canada

Your file *Votre référence*
ISBN: 978-0-494-18591-9
Our file *Notre référence*
ISBN: 978-0-494-18591-9

NOTICE:

The author has granted a non-exclusive license allowing Library and Archives Canada to reproduce, publish, archive, preserve, conserve, communicate to the public by telecommunication or on the Internet, loan, distribute and sell theses worldwide, for commercial or non-commercial purposes, in microform, paper, electronic and/or any other formats.

The author retains copyright ownership and moral rights in this thesis. Neither the thesis nor substantial extracts from it may be printed or otherwise reproduced without the author's permission.

AVIS:

L'auteur a accordé une licence non exclusive permettant à la Bibliothèque et Archives Canada de reproduire, publier, archiver, sauvegarder, conserver, transmettre au public par télécommunication ou par l'Internet, prêter, distribuer et vendre des thèses partout dans le monde, à des fins commerciales ou autres, sur support microforme, papier, électronique et/ou autres formats.

L'auteur conserve la propriété du droit d'auteur et des droits moraux qui protègent cette thèse. Ni la thèse ni des extraits substantiels de celle-ci ne doivent être imprimés ou autrement reproduits sans son autorisation.

In compliance with the Canadian Privacy Act some supporting forms may have been removed from this thesis.

Conformément à la loi canadienne sur la protection de la vie privée, quelques formulaires secondaires ont été enlevés de cette thèse.

While these forms may be included in the document page count, their removal does not represent any loss of content from the thesis.

Bien que ces formulaires aient inclus dans la pagination, il n'y aura aucun contenu manquant.

Canada

ABSTRACT

The engagement of CD28 receptor with the B7-1 or B7-2 ligands on antigen presenting cells, provide the critical second co-stimulatory signal for the immune activation of T lymphocytes. The molecular mechanisms by which B7-1 or B7-2 expressions are regulated are not well understood.

I investigated the role of mitogen-activated protein (MAPKs) in the regulation of lipopolysaccharide (LPS)-induced B7-1 expression in human monocytes and the promonocytic THP-1 cells. My results show that LPS-induced B7-1 expression in monocytic cells did not involve the activation of either p38 or ERK kinases. By employing JNK inhibitors SP600125, dexamethasone and curcumin that inhibit JNK activation, LPS-induced B7-1 expression was determined to be regulated by JNK MAPKs in both monocytes and THP-1 cells. Also, I identified a distinct B7-1 regulatory element corresponding to the interferon regulatory factor-7 (IRF-7) binding site on the B7-1 promoter, responsible for the regulation of LPS-induced B7-1 transcription. Furthermore, SP600125 and dexamethasone inhibited LPS-induced IRF-7 activity as determined by the luciferase reporter and gel shift assays. Taken together, the results suggest that LPS-induced B7-1 transcription in human monocytic cells may be regulated by IRF-7 transcription factor through JNK MAPKs activation.

I also studied the role of MAP kinases in the regulation of B7-2 expression in LPS stimulated human monocytic cells. LPS stimulation of human monocytes resulted in the down-regulation of B7-2 expression that could be abrogated by anti-IL-10 antibodies. My results reveal the distinct involvement of p38 in IL-10 dependent, and JNK in IL-10-independent regulation of B7-2 expression in LPS-stimulated monocytic cells. In addition, by deletion and mutant B7-2 promoter/luciferase gene analysis I identified 3 positive regulatory elements on the B7-2 promoter, NF- κ B, IRF-2, and an unidentified binding site region that operate cooperatively to control B7-2 expression.

Elucidating the signal pathway and molecular mechanisms in the regulation of B7-1 and B7-2 in antigen presenting cells is important as it could provide us with a better understanding of the molecular basis for CD28/B7 co-stimulation. This in turn, may lead to the development of strategies in treating autoimmune diseases, organ transplantation rejections, graft-versus-host disease, infections, and cancer.

ACKNOWLEDGEMENTS

I wish to express my gratitude to my supervisor, Professor Ashok Kumar for his constructive insights and suggestions that helped me to shape my research skills and for his important support throughout this work. I thank my thesis committee members, Dr. Francisco Diaz-Mitoma, Dr. Maya Kozlowski, and Dr. Henry Fliss for their valuable advice and feedback. In addition, I thank all the students and staff, whose presences enhanced my experience in the laboratory. They are: Dr. Marko Kryworuchko and his term “social neophyte”, the “ubiquitous” Dr. Katrina Gee, Wei Ma, Bill Weiss and for all of the hockey bets, Sasmita Mishra, Jyoti Mishra, Ali Rahimi, Dr. Masoud Ghorbani, Irene Chan, Sunny Chu, Ali Azizi, Turaya Naas, Khaled Abdkader, Abdulkarim Al-hetheel, Catalina Soare, Susan Aucoin and for her generous “sirloin steak” b-day presents, Rita Frost and for her wonderful desserts including my wedding cake, Angela Bueti, and Nirangenla Gajanayaka. Especially, I owe my deepest thanks to my wife Debbie whose love, patience and encouragement enabled me to complete this dissertation.

TABLE OF CONTENTS

Abstract	ii
Acknowledgements	iii
List of Abbreviations	vi
List of Figures and Illustrations	viii
List of Tables	x
Chapter 1: Introduction	1
T Lymphocyte Activation and Function	2
Co-stimulation and the Two-Signal Model	4
Structure of B7-1 and B7-2	6
B7 Extended Family	9
Expression of B7-1 and B7-2 on Immune Cells	10
Biological Functions of B7-1 and B7-2	12
Th1/Th2	12
Autoimmunity	13
Tumor Immunity	14
Infection	15
Transplant Rejection	17
Expression and Regulation of B7-1 Expression by Cytokines and LPS	18
Expression and Regulation of B7-2 Expression by Cytokines and LPS	19
Signal Transduction	20
General Signaling	20
LPS-mediated signal transduction and TLR4	23
MAP kinase signaling	26
Anti-inflammatory cytokine IL-10 and its biological functions	29
B7-1 Gene Regulation and Transcription Factors	32
B7-2 Gene Regulation and Transcription Factors	36
Rationale and Hypothesis	38
Chapter 2: Materials and Methods	40
Chapter 3: Studies on the regulation of B7-1 in human monocytic cells	56
Introduction	57
Results	58
Chapter 4: Studies on the regulation of B7-2 in human monocytic cells	81
Introduction	82
Results	83
Chapter 5: Discussion	112

Chapter 6: Conclusion, Significance, and Future Directions	132
References	137

LIST OF ABBREVIATIONS

aa	Amino Acid
AP-1	Activator of Protein-1
APC	Antigen Presenting Cell
ATCC	American Type Culture Collection
B7-1, B7-2	CD80, CD86 Co-stimulatory Molecules
B7-H1-4	B7-homologs
B7-RE	B7-regulatory Element
bp	Base Pair
BSA	Bovine Serum Albumin
BTLA	B and T Lymphocyte Attenuator
CD	Cluster of Differentiation
cDNA	Complementary DNA
CREB	Cyclic AMP Responsive Element Binding Protein
CTL	Cytotoxic T Lymphocyte
CTLA-4	Cytotoxic T Lymphocyte Antigen-4
CTLA-4 Ig	CTLA-4 Immunoglobulin Fusion Protein
dNTP	Deoxynuceotide Triphosphate
DAG	Diacylglycerol
DN	Dominant Negative
EAE	Experimental Allergic Encephalomyelitis
EBV	Epstein Barr Virus
ECL	Enhanced Chemiluminescence
ELISA	Enzyme-linked Immunosorbent Assay
EMSA	Electrophoretic Mobility Shift Assay
ERK	Extracellular-related Kinase
FBS	Fetal Bovine Serum
GAS	Interferon- γ Activating Site
GM-CSF	Granulocyte Macrophage Colony Stimulating Factor
GPI	Glycosylphosphatidyl Inositol
HLA	Human Lymphocyte Antigen
HTLV-1	Human T cell Leukemia Virus Type-1
ICOS	Inducible T-cell Costimulator
IMDM	Iscove's Modified Dulbecco's Medium
IFN- γ	Interferon Gamma
Ig	Immunoglobulin
IgV	Immunoglobulin Variable-like
IgC	Immunoglobulin Constant-like
IL	Interleukin
IMDM	Iscove's Modified Dulbecco's Medium
IP ₂	Phosphatidyl Inositol (4,5)-biphosphate
IP ₃	Inositol 1,4,5-triphosphates
IRAK	IL-1R-Associated Kinase
IRF	Interferon Regulatory Factor
IRS-1	Insulin Receptor Substrate-1

JAK	Janus Kinase
JNK/SAPK	c-jun N-terminal Kinase/Stress Activated Protein Kinase
KD	Kilodalton
LPS	Lipopolysaccharide
LBP	LPS-binding Protein
mAb	Monoclonal Antibody
MCF	Mean Channel Fluorescence
MHC	Major Histocompatibility Complex
MAP	Mitogen-associated Protein
MAPK	Mitogen-associated Protein Kinase
MAPKK	MAPK Kinase
MAPKKK	MAPKK Kinase
MEK	MAP Kinase/ERK Kinase
mRNA	Messenger RNA
NF- κ B	Nuclear Factor- κ B
ng	Nanogram
NIK	Nuclear Factor- κ B Inducing Kinase
nt	Nucleotides
NOD	Non-obese Diabetic
PAK	p21-activated Kinase
PBMC	Peripheral Blood Mononuclear Cells
PBS	Phosphate Buffered Saline
PCR	Polymerase Chain Reaction
PD-1	Programmed Death-1
PD-L1, 2	Programmed Death Ligand
PHA	Phytohemagglutinin
PI3-kinase	Phosphoinositol 3'-kinase
PKC	Protein Kinase C
PLC	Phospholipase C
PMA	Phorbol 12-myristate 13-acetate
PRD	Positive Regulatory Domain
PTK	Protein Tyrosine Kinase
RT-PCR	Reverse Transcription-Polymerase Chain Reaction
SDS-PAGE	Sodium Dodecyl Sulfate-Polyacrylamide Gel Electrophoresis
SH2	Srch Homology 2
SOCS	Suppressor of Cytokine Signaling
SOS	Son of Sevenless
STAT	Signal Transducer and Activator
TCR	T Cell Receptor
Th	T Helper Cells
TLR	Toll Like Receptor
TNF	Tumor Necrosis Factor
TRAF6	TNF-Receptor-Associated Factor-6
Ts	T Suppressor Lymphocytes

LIST OF FIGURES AND ILLUSTRATIONS

Fig. 1-1: Two-signal model involved in T cell activation	5
Fig. 1-2: Structure and genomic organization of the genes coding for B7-1 and B7-2	7
Fig. 1-3: Generalized intracellular signaling pathways	21
Fig. 1-4: LPS-mediated signaling pathway on human monocytic cells	25
Fig. 1-5: MAP kinase pathways	27
Fig. 1-6: Human B7-1 promoter	34
Fig. 1-7: Human B7-2 promoter	37
Fig. 3-1: LPS up-regulates B7-1 expression in monocytes	60
Fig. 3-2: LPS-induced B7-1 expression in human monocytes is not regulated by p38 or ERK MAPKs	61
Fig. 3-3: LPS-induced B7-1 expression in human monocytes is regulated by JNK MAPKs	63
Fig. 3-4: Flow cytometric analysis of CD14 expression on THP-1 and THP-1/CD14 cells	64
Fig. 3-5: LPS up-regulate B7-1 expression in THP-1/CD14 cells	65
Fig. 3-6: LPS-induced B7-1 expression in THP-1/CD14 cells is regulated by JNK MAPKs	66
Fig.3-6C: LPS-induced B7-1 expression in THP-1/CD14 cells is regulated by JNK MAPKs as determined by siRNA for JNK1 and JNK2	68
Fig. 3-7: LPS-induced B7-1 mRNA expression in human monocytes and THP-1/CD14 are regulated by JNK MAPKs	69
Fig. 3-8: Optimization experiments for the DEAE-Dextran transfection	72
Fig. 3-9: LPS-stimulation induces luciferase activity in THP-1/CD14 cells transfected with a B7-1 promoter/luciferase reporter gene construct	73
Fig. 3-10: Transcriptional activities of B7-1 promoter in LPS-stimulated THP-1/CD14 cells	75
Fig. 3-11: SP600125 inhibits LPS-mediated B7-1 promoter activity in THP-1/CD14 cells	77
Fig. 3-12: LPS stimulation activates an IRF-7 transcription factor which is inhibited by inhibitors of JNK	79
Fig. 4-1: LPS and IL-10 down-regulate B7-2 expression in purified human monocytes	84
Fig. 4-2: Role of p38 and p42/44 MAP kinases in B7-2 expression and IL-10 production in LPS-stimulated human monocytes	87
Fig. 4-3: Role of p38 MAP and p42/44 MAP kinases in B7-2 expression in IL-10-stimulated human monocytes	89
Fig. 4-4: Exogenous addition of human recombinant IL-10 reverses the SB202190-induced effect of B7-2 expression in SB202190 pretreated LPS-stimulated monocytes	91
Fig. 4-5: LPS induces B7-2 expression in THP-1 cells	94
Fig. 4-6: Role of p38 and p42/44 MAP kinases in B7-2 expression in LPS-stimulated THP-1 cells	96

Fig. 4-7: Dexamethasone and SP600125 inhibits LPS-induced phosphorylation of JNK kinase and LPS-mediated B7-2 expression in THP-1 cells	98
Fig. 4-8: Dexamethasone and SP600125 inhibits LPS-induced phosphorylation of JNK kinase and LPS-mediated B7-2 expression in human monocytes	99
Fig. 4-9: Dominant negative mutant of MKK-4 inhibits LPS-induced B7-2 expression in THP-1 cells	101
Fig. 4-10: Effect of dexamethasone on LPS-induced activation of NF- κ B and AP-1 transcription factors in THP-1 cells	103
Fig. 4-11: Optimization experiments for the DEAE-Dextran transfection of pGL3Control plasmid DNA into THP-1 cells	105
Fig. 4-12: LPS-stimulation induces luciferase activity in THP-1 cells transfected with a B7-2 promoter/luciferase reporter gene construct	107
Fig. 4-13: Transcriptional activities of B7-2 promoter in LPS-stimulated THP-1 cells	108
Fig. 4-14: Effect of mutating the NF- κ B, CREB, or IRF-2 regions on B7-2 promoter activity in LPS-stimulated THP-1 cells	111
Fig. 5-1: Model of the regulation of B7-1 costimulatory molecule by LPS in human monocytic cells	123
Fig. 5-2: Model on the regulation of B7-2 costimulatory molecule by LPS in human monocytic cells	131

LIST OF TABLES

TABLE 2-1: Primer sequences used to amplify the B7-1 promoter fragments from genomic DNA	51
TABLE 2-2: Primer sequences used to amplify the B7-2 promoter fragments from genomic DNA	52
TABLE 3-1: Pretreatment of signaling inhibitors had no toxic effect on THP-1/CD14 cells	70
TABLE 4-1: Effect of human recombinant IL-10 on B7-2 expression in SB202190 pretreated LPS-stimulated monocytes	92

CHAPTER 1:
INTRODUCTION

Introduction

T Lymphocyte Activation and Function

The immune system plays a pivotal role in recognizing and destroying foreign substances. This is primarily mediated by T and B lymphocytes, which are able to discriminate between self versus non-self antigens during an adaptive immune response against pathogens. T lymphocytes are generated in the thymus and circulate through the bloodstream and primary lymphoid organs such as the lymph nodes and spleen. Because they have not yet encountered a specific antigen, they are referred to as “naïve” T-cells. But upon encounter with antigen presenting cells (APCs) such as macrophages, B cells, and dendritic cells, they become activated and begin to proliferate and differentiate. Activation of T-cells requires two signals. The first or primary signal involves recognition of the antigen in the proper context of an MHC Class I or MHC Class II molecule by the T cell receptor (TCR). The second or accessory signal, require the CD28 molecule which is constitutively expressed on naïve T-cells to bind to the B7 ligands on antigen-presenting cells. Naïve T-cells express only the IL-2R β and γ chains which form low affinity IL-2 receptors. Upon activation, the α chain is also expressed to form high affinity IL-2 receptors for the binding of growth factor IL-2, which allow T lymphocytes to proliferate.

Thymus-derived lymphocytes are a heterogeneous cell population, which can be subdivided into helper T cells (Th) and cytolytic T cells (Tc), based on their molecular markers and functional characteristics (1). Helper T cells express CD4 cell surface markers and play a role in antibody synthesis and promote the development of CD8+ T-

cell responses. Cytotoxic T lymphocytes (CTL) which express CD8 recognize intracellular pathogens and tumor cells via the Class I MHC molecule. T lymphocytes expressing CD4 consist of 2 populations, Type 1 helper cells (Th1) and type 2 helper cells (Th2), which both are derived from a naïve Th0 precursor. The Th1/Th2 paradigm was originally demonstrated by Mossmann and Coffman, where they showed that mouse CD4⁺ T lymphocytes consisted of two distinct subsets based on their patterns of cytokine expression (2). Interferon γ (IFN- γ) promoted the development of Th1 clonal expansion, while limiting the expansion of Th2 cells. IL-4 favored the development of Th2, while suppressing the generation of Th1 cells. Th1 cells secrete IL-2, IFN- γ , tumor necrosis factor β (TNF- β), and granulocyte macrophage colony stimulating factor (GM-CSF), whereas Th2 cells produce IL-4, IL-5, IL-6, IL-10 and IL-13 cytokines. Th1 cells play an important role in cell mediated immune responses, such as delayed type hypersensitivity and activation of CD8⁺ T lymphocytes and macrophages. Thus, the Th1 cells are best suited in killing of intracellular pathogens and viruses. As well, Th1 cells can also induce IgG2a production in B cells. On the other hand, Th2 cells are involved in humoral immune responses, including B cell activation and secretion of IgG1 and IgE antibodies. Thus, Th2 responses provide protective immunity against bacteria and parasites such as helminths.

The Th1/Th2 model has been extensively applied in studies of infectious and autoimmune diseases. A classic example is that of inbred mice strain infected with the intracellular protozoan parasite, *Leishmania major*. C57B1/6 mice which were resistant to the parasitic infection developed a strong Th1 response. BALB/c mice which were susceptible to *Leishmania* infection and which ultimately died from a progressive

infection, predominantly developed a Th2 response. In human patients infected with the *Mycobacterium leprae*, it has been observed that the tuberculoid leprosy form arises in patients mounting a Th1 response. In contrast, leprosy patients mounting a Th2 response develop the more severe lepromatous disease. The Th1/Th2 paradigm has implications in the treatment of diseases and vaccine development. For instance, it was found that IL-4 knockout mice which no longer developed Th2 responses, were protected from death by murine acquired immunodeficiency syndrome from a murine leukemia virus (3). From this result, many investigators rationalize that the induction of a stable Th1-like state may aid in the design of a vaccine or as a vaccine strategy (3).

Co-stimulation and the Two-Signal Model

The “two signal” hypothesis was originally postulated by Bretscher and Cohn (4). The original hypothesis stated that activation of the immune system requires two signals, an antigen-specific signal and a less specific signal from another molecule. Similarly, in order for a T cell to be activated, two signal components are necessary which are provided by antigen presenting cells consisting of monocytes/macrophages, B cells, or dendritic cells (Fig. 1-1). The first signal is antigen-specific and involves T-cell receptor recognition and binding to the MHC/antigen on the surface of the APC. The second signal or co-stimulatory signal is non-specific and involves the CD28 receptor on the T cell binding to the B7-1 or B7-2 ligands on the APC. Delivery of the first signal alone, without the second co-stimulatory signal, leads to T cell anergy or even apoptosis. This T cell activation results in the clonal expansion of antigen-specific T cells and production of lymphokines, such as IL-2, IL-3, IL-4, GM-CSF, TNF- α , and IFN- γ . A second receptor

FIGURE 1-1: Two-signal model involved in T cell activation.

T cell activation requires two signals. The first signal is specific and involves TCR recognition and binding to the MHC/antigen on APC. The second signal is non-specific and requires the CD28 receptor on T cell to bind to the B7-1 or B7-2 ligands. B7-1 and B7-2 also binds to the inhibitory receptor CTLA-4 on T cells which delivers a negative signal terminating T cell responses.

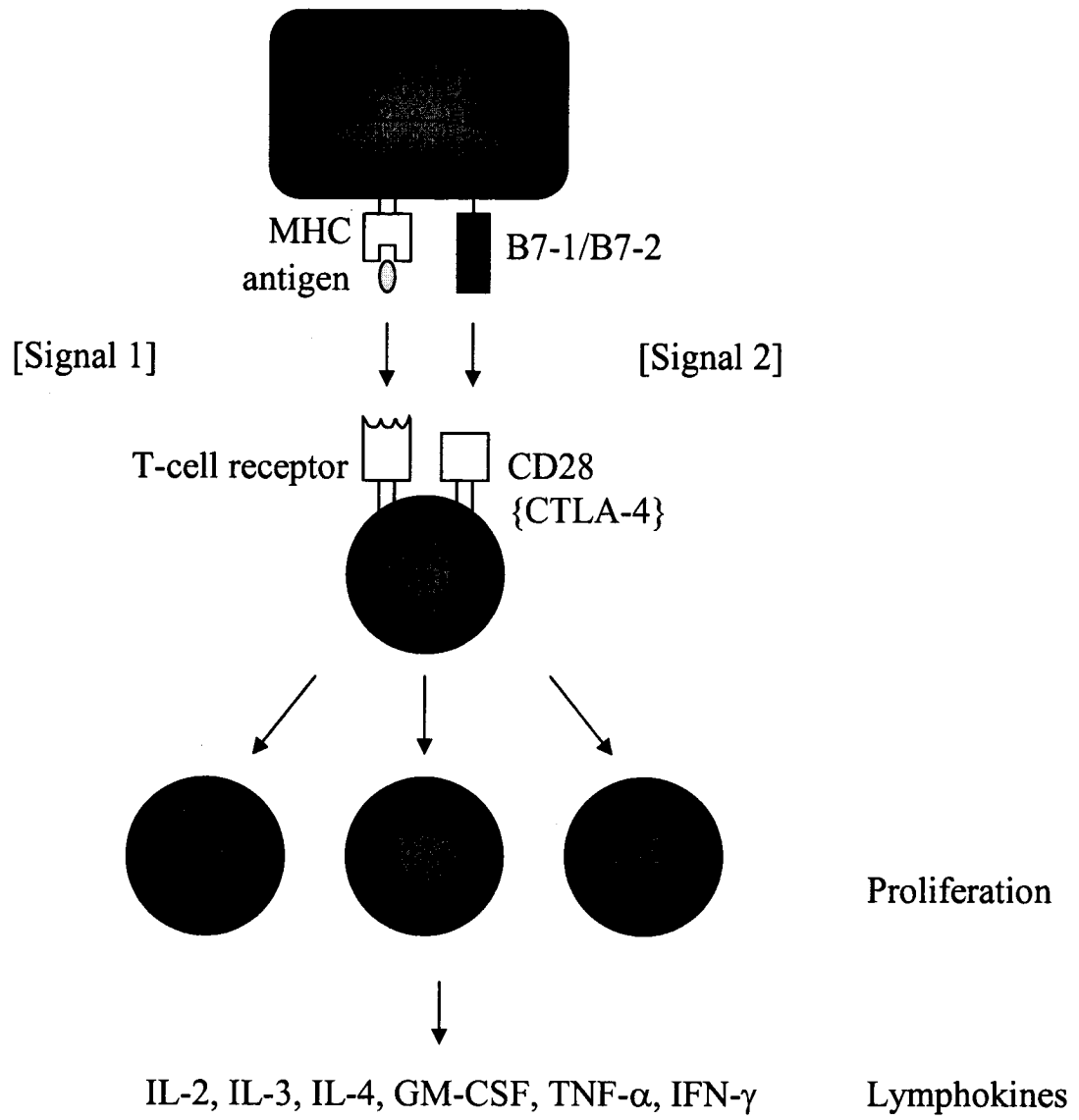

for the B7-1 or B7-2 ligands is CTLA-4 (CD152), which sends an inhibitory signal down-regulating T cell activation. CTLA-4 is not present on resting T lymphocytes but is up-regulated upon T cell activation. Therefore, the B7-1 and B7-2 co-stimulatory molecules play an essential role in the activation and regulation of immune responses. Specifically, blocking the CD28/B7 co-stimulatory pathway results in immunosuppression and the potential inhibition of autoimmune diseases and transplant rejections. Whereas, activating the CD28/B7 pathway could be therapeutic in recognizing and eliminating tumors and infections that evade the immune system. Despite their structural similarities and their ability to function as co-stimulatory molecules, B7-1 and B7-2 have been suggested to play a distinct role in development of immune responses and the pathogenesis of a number of infectious and autoimmune diseases. Since my research project is aimed at understanding the regulation of B7 co-stimulatory molecules on antigen presenting human monocytic cells, I will review the structure, expression and functional role of B7-1 and B7-2 co-stimulatory molecules and the current understanding of their signaling transduction and gene regulation in the following sections.

Structure of B7-1 and B7-2

The family of B7 co-stimulatory molecules consists of two classical members, B7-1 (CD80) and B7-2 (CD86), which are present on the cell surface as monomers. Both belong to the immunoglobulin superfamily and consists of a single immunoglobulin variable (IgV)-like and immunoglobulin constant (IgC)-like domain with sites for N-linked glycosylation (Fig. 1-2). The B7 ligands interact with the CD28 and CTLA-4

FIGURE 1-2: Structure and genomic organization of the genes coding for B7-1 and B7-2.

(A) Structure of B7-1 and B7-2. B7-1 and B7-2 type I membrane proteins belonging to the immunoglobulin (Ig) gene superfamily. They consist of IgV-like, and IgC-like extracellular domains, a transmembrane domain, and a cytoplasmic tail. B7-2 has an extended cytoplasmic domain which may be involved in signaling.

(B) Genomic organization of B7-1 and B7-2. The B7-1 and B7-2 genes contain 6 and 8 exons, respectively. The exons are numbered in the boxes.

A.

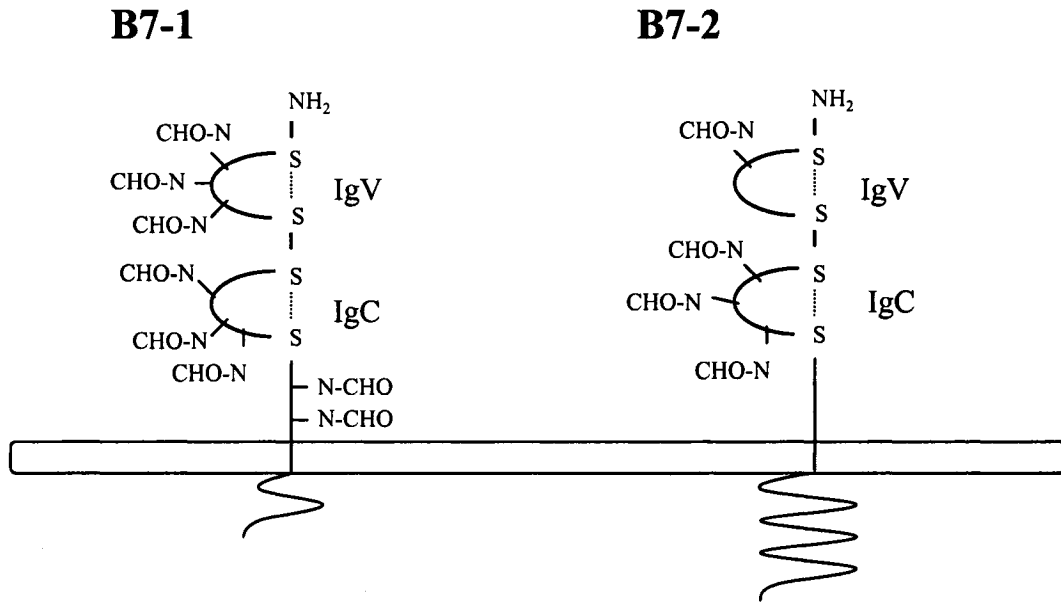

B.

B7-1

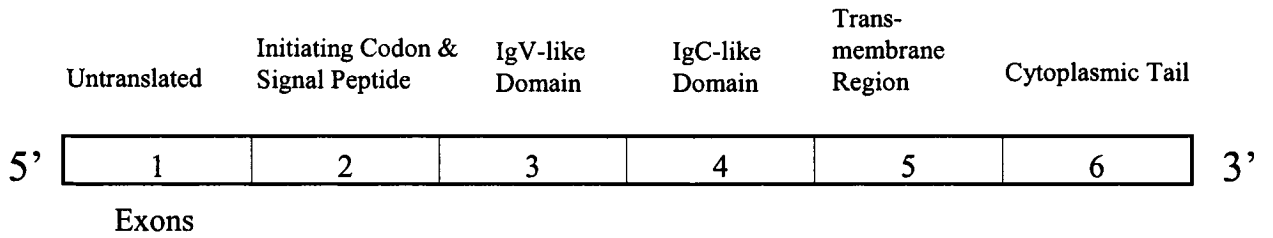

B7-2

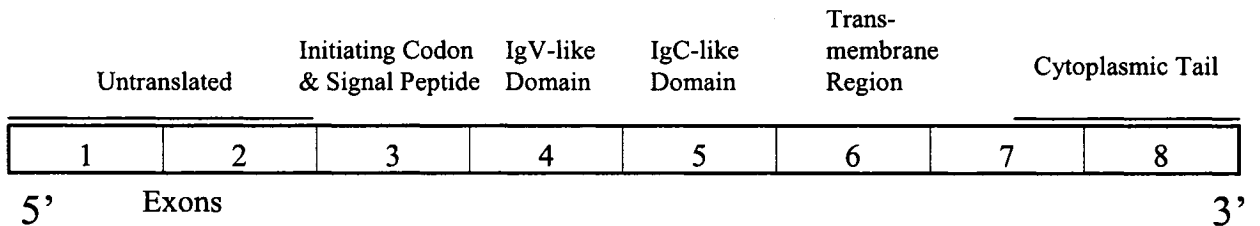

receptors through the GFCC'C' beta sheet face of their IgV-like domain and the ABED beta sheet face of their IgC-like domain. The labeling of the beta sheet face is based on standard immunoglobulin nomenclature. Although the B7 ligands bind to both receptors on the T cells, the B7 ligands bind to CTLA-4 with 20 to 100 fold greater affinity than to CD28 (5). The dissociation rates for B7-1 and B7-2 differ as well. B7-1 binds to both CD28 and CTLA-4 receptors two to three times stronger, with faster binding kinetics, and with slower dissociation constants than B7-2 (6-8).

The cDNAs for both B7-1 and B7-2 have been isolated and predicted to encode type I membrane proteins of the immunoglobulin superfamily and exhibited only 25% sequence homology (Fig. 1-2). B7-1 is a 55 kDa type I membrane glycoprotein consisting of 288 amino acids. It is made up of a secretory signal peptide followed by 2 contiguous Ig-like extracellular domains, a hydrophobic transmembrane region, and a short 19 amino acid cytoplasmic domain (9). B7-2 is a 70 kDa type I membrane glycoprotein consisting of 329 amino acids. It also has a secretory signal peptide with 2 Ig-like domains, but with an extended cytoplasmic domain which may contain potential phosphorylation sites for protein kinase C (9).

B7-1 and B7-2 are encoded by separate genes found on human chromosome 3q13.3-3q21 (10,11). The cDNAs encoding the human B7-1 and B7-2 gene have been isolated and its genomic organization reported. In humans, the B7-1 locus spans 32 kilobases of DNA and is composed of six exons (10). Exon 1 is not translated, while exon 2 encodes the initiation ATG codon and the signal peptide (10). Exons 3 and 4 correspond to the IgV- and IgC-like extracellular domains (10). Finally exons 5 and 6 encode the transmembrane region and cytoplasmic tail, respectively (10). The B7-2 gene

is composed of eight exons, which span 22 kilobases (11). Exons 1 and 2 correspond to the 5' untranslated sequences and exon 3 encodes the signal peptide (11). Exons 4 and 5 correspond to IgV- and IgC-like extracellular domains, respectively (11). Exon 6 encodes the transmembrane region and beginning of the cytoplasmic tail (11). Exons 7 and 8 encode the remainder of the cytoplasmic tail and 3' untranslated sequences (11). The genomic organization of B7-1 is similar to B7-2 except at the 3' end of the gene. Whereas, the cytoplasmic tail for B7-2 spans from exons 7 to 8, the cytoplasmic tail of B7-1 is found entirely in the final sixth exon.

B7 Extended Family

B7-1 and B7-2 were the first B7 family members to be identified. But, in the last few years, several new members of the B7 family such as B7-H2, B7-H1, B7-DC, B7-H3, and B7-H4, have been discovered by screening techniques such as subtractive hybridization, human cDNA expressed sequence tag searches, and amino acid alignment sequence searches. The classification of B7 extended family ligands is based on common structural aspects with B7-1 and B7-2 and their abilities to co-stimulate or inhibit T lymphocytes. However, their function differs in that they do not bind to CD28 or CTLA-4.

The third member of the B7 family to be identified is B7-homolog 2 (also designated as B7-H2, B7h, B7RP-1, ICOS-L, GL-50), which binds to an inducible T-cell co-stimulator (ICOS) receptor on activated T cells (12). B7-H2 which functions to costimulate T cells, shares approximately 20% amino acid homology with that of B7-1 and B7-2 (13,14). As well, it is constitutively expressed in B cells, and dendritic cells

(15). In monocytes, B7-homolog is expressed at low levels but is up-regulated upon stimulation with IFN- γ (15,16).

The fourth B7 family member is B7-homolog 1 (B7-H1) or programmed death 1 ligand (PD-L1), which binds to the programmed death-1 (PD-1) receptor on activated T and B cells (17,18). B7-H1 exhibits 20% and 15% amino acid homology with that of B7-1 and B7-2, respectively (15). It is constitutively expressed in dendritic cells and is induced by IFN- γ in keratinocytes (15,19). B7-H1 is not expressed in resting monocytes but is activated upon stimulation with IFN- γ and LPS (19).

The fifth B7 family member is B7-DC or programmed death 2 ligand (PD-L2), which also binds to the PD-1 receptor. Engagement of B7-H1 and B7-DC to the PD-1 receptor serves to inhibit activation of T and B cells (15,17,18). Though PDL-2 shares approximately 37% homology with PDL-1, unlike PDL-1 it is expressed in resting monocytes (15,20).

B7-H3, the sixth B7 family member does not bind to any of the CD28, CTLA-4, ICOS, or PD-1 receptors, and to this day its receptor has yet to be identified (20). B7-H3 is expressed in IFN- γ stimulated dendritic cells and in GM-CSF stimulated monocytes (21). The seventh and last B7 family member is B7-H4 (B7x/B7-S1), which engages the B and T lymphocyte attenuator (BTLA) and inhibits T cell activation (22,23).

Expression of B7-1 and B7-2 on Immune Cells

Because my research project is focused primarily on the regulation of B7-1 and B7-2 expression, I will be describing in detail the biological and functional roles of these co-stimulatory molecules. Since the B7-1 and B7-2 co-stimulatory molecules play a

critical role in providing the secondary signal towards immune activation, their expression is predominantly restricted to professional APCs including monocytes, dendritic cells, Langerhans cells, and B cells. B7-1 is not constitutively expressed in resting APCs, whereas, B7-2 is constitutively expressed in resting monocytes and dendritic cells *in vitro* (24-26). Upon activation, B7-1 is expressed on monocytes, dendritic cells, Langerhans cells, and B cells (27,28). B7-2 expression is also up-regulated after activation of dendritic cells, Langerhans cells, B cells, and T cells (9,24,28). In fact, on resting monocytes where B7-2 is constitutively expressed, B7-2 can be further expressed to higher levels by the appropriate stimulus such as LPS (29,30). The presence of B7-1 on CD4⁺ T cells appears to also play a co-stimulation role in that it allows for T-T cell interaction and enhance proliferation of other T cells (31,32). B7-2 expressed on T cells is in a hypoglycosylated form and rather than co-stimulation it seems to inhibit T cell activation by preferentially binding to CTLA-4 (33,34).

The temporal expression of B7-1 and B7-2 after activation is different. For instance, when B lymphocytes are activated, B7-2 is rapidly expressed followed by B7-1 24 to 48 hours later (9,35). Not only is the expression of B7-2 enhanced faster than B7-1 after activation, the level of expression of B7-2 is also higher. In freshly isolated human monocytes, B7-1 mRNA expression is up-regulated upon stimulation with LPS or purified protein derivative of tuberculin (29). This corresponds with protein expression where B7-1 is weakly detected only after 6 to 8 hours of induction (29). In human monocytes and MonoMac6 cell lines, B7-2 mRNA and protein is constitutively expressed (29,36,37). Upon these observations, it is believed that B7-2 rather than B7-1 is involved in the initial interaction with CD28 or CTLA-4. Thus, the differential expression of the

two co-stimulatory molecules on various cells and with different time kinetics suggest that B7-1 and B7-2 ligands may play unique roles in modulating an immune response.

Biological Functions of B7-1 and B7-2

Activation of T cells is important for an effective immune response against tumors and infectious agents. Whereas, improper activation of T cells may lead to the development of autoimmune and graft versus host diseases. Since, the molecules B7-1 and B7-2 play a crucial role in T cell activation and immune tolerance, therefore, an altered expression and regulation of B7 molecules especially B7-1 and B7-2, play a key role in a number of immunobiological functions and in the pathogenesis of infectious and autoimmune diseases and cancer.

Th1/Th2

There is evidence to suggest that B7-1 or B7-2 co-stimulation may play a role in the skewing of Th1 versus Th2 responses. In fact, several studies have suggested that B7-2 engagement of CD28 favors the induction of IL-4 expression and drives the immune response toward a Th2 differentiation pathway (38-40). In an experimental model of *Leishmania major* infection in susceptible BALB/c mice, administration of anti-B7-2 but not anti-B7-1 antibodies was shown to block Th2 development and also prevented disease progression (41). Similarly, another group determined that IL-2, IL-4, and IL-5 production in T lymphocytes that were incubated with peritoneal exudates macrophages was depressed upon administration of anti-B7-2 but not anti-B7-1 antibodies, whereas, IFN- γ production in T lymphocytes was significantly blocked by

either anti-B7-2 or anti-B7-1 antibodies (42). On similar lines, another study demonstrated that using ovalbumin-specific T cells, anti-B7-2 monoclonal antibodies were capable of reducing IL-4 production (9).

In an experimental allergic encephalomyelitis mouse model, treatment with anti-B7-1 antibodies reduced the severity of the disease, while anti-B7-2 either had no effect or increased its severity (43,44). Using B7-1 knockout mice, Schweitzer et al. demonstrated that the presence of B7-1 on T cells can inhibit IL-4 production (45). And in a murine Schistosomiasis model, granuloma macrophages which had reduced B7-1 and B7-2 expression, induced Th1 unresponsiveness by secretion of IL-10 (46,47). It is not exactly clear whether B7-1 favors Th1 or Th2 development. So more investigation is required before we can exploit this potential strategy to treat certain types of infectious diseases.

Autoimmunity

Autoimmune diseases occur as an adaptive immune response directed at self-antigens. In the two-signal model for T cell activation, T cells must recognize self-antigens and must also receive the second co-stimulatory signal to proliferate. Most tissues do not express the co-stimulatory molecules and thus, should not be able to co-stimulate T cells. But if a subset of T cells no longer require the second signal to be activated, or if a tissue begins to express co-stimulatory molecules, autoimmunity may occur. We see evidence of this with patients suffering from rheumatoid arthritis, where B7-1 is expressed aberrantly on B cells, T cells, and monocytes at sites of autoimmune pathology (48). And it has been clearly demonstrated that nonobese diabetic (NOD) mice

made to express B7-1 on pancreatic β cells, under the control of the rat insulin promoter, develop accelerated diabetes (49). So attempts have been made to selectively block B7-1 or B7-2 ligands to prevent the development of autoimmune diseases. But results obtained thus far has been perplexing. For instance, in NOD mice treated with anti-B7-1 antibodies, the onset and severity of diabetes mellitus is accelerated, while treatment with anti-B7-2 or CTLA4-Ig inhibits this disease (50). In a murine model of systemic lupus erythematosus, the disease is inhibited only by blocking both B7-1 and B7-2 (51). While in experimental allergic encephalomyelitis, a murine model of multiple sclerosis, treatment with anti-B7-1 antibodies improves the disease, whereas, anti-B7-2 or anti-CTLA-4 antibody treatment exacerbates the disease (52,53). Therefore, the CD28/B7 co-stimulatory pathway plays a critical role in the induction and regulation of autoreactive T cells, but the differential requirement for B7-1 or B7-2 in the induction of various autoimmune diseases remains unclear.

Tumor immunity

Though tumor cells may express tumor-specific antigens, the majority of these cells are of low immunogenicity or lack co-stimulatory molecules, or both. Therefore, inducing the expression of B7-1 or B7-2 co-stimulatory molecules in malignant cells should enhance anti-tumor immunity. In fact, this has been demonstrated in several murine models, which resulted in the rejection of the tumor. For instance, B7 transfected murine melanoma cells are able to direct CD8⁺ T cells to reject melanoma cells *in vivo* (54). In a mouse sarcoma model, anti-sarcoma responses by MHC class II⁺ tumor cells expressing B7-1 is generated and is primarily mediated by CD4⁺ T cells (55). As well,

inoculation of mice with mastocytoma P815 tumor cells transfected with B7-2 protected the mice against subsequent challenge with the lethal wild-type P815 tumor (56). Similarly, in a murine model of acute myeloid leukemia, expression of B7-1 rather than B7-2, better protected mice against challenge with the wild-type tumor (57). From all these studies in murine tumor models, it seems that expression of B7 on tumor cells can lead to the activation of T cells resulting in tumor rejection. The studies also demonstrate that the B7-1 and B7-2 co-stimulatory molecules give diverse results in inducing anti-tumor immunity. So these results further reinforce the idea that B7-1 and B7-2 may have distinct and overlapping functions in their role in immune activation.

Infection

Models of infection have also been important in demonstrating the importance of B7 co-stimulatory molecules in the development of effective immune responses. There is evidence to suggest that bacterial and protozoan cell wall protein can modulate the expression of B7-1 or B7-2 on antigen presenting cells. For example, proteins isolated from *Neisseria meningitidis*, and *N. gonorrhoea* up-regulate B7-2 expression but not B7-1 expression in B cells (58). Lipopolysaccharide, a Gram-negative bacteria cell wall component, up-regulates B7-1 expression and down-regulates B7-2 expression in human monocytes (30). As well, B7-1 expression is reduced in *Mycobacterium tuberculosis* and *Leishmania donovani* infected macrophages (59,60). The tachyzoites of the intracellular pathogen, *Toxoplasma gondii* can induce the expression of both B7-1 and B7-2 in human monocytes (61). Also, during an infection with the helminth *Schistosoma mansoni*,

granulomas may form around the eggs of parasites in the liver resulting in down-regulation of B7-1 and B7-2 expressions on granuloma macrophages (46).

Similar to the studies performed in several experimental models of autoimmune diseases, blocking or alteration of expression of B7-1 or B7-2, can result in the modulation of immune responses against a number of infectious organisms and thereby alter disease progression. A classic model for studying Th1 and Th2 development involves infection of inbred mice strain with the intracellular protozoan parasite *Leishmania major*. C57B1/6 mice which are resistant to infection will develop a Th1 response, whereas BALB/c mice which are susceptible to infection with *Leishmania major* will develop a Th2 response. To determine the effects of blocking B7 on Th1 and Th2 response, studies were performed utilizing CTLA-4 Ig. Soluble CTLA-4 Ig fusion protein is composed of human CTLA-4 and the immunoglobulin G1 Fc region and is able to bind to both B7-1 and B7-2 with high avidity, thereby blocking T cell activation. When resistant C57B1/6 mice were treated with CTLA-4 Ig, there was no effect on the disease. But in susceptible BALB/c mice, early administration of CTLA-4 Ig after infection resulted in reduced IL-4 production and a halt in disease progression (62).

Furthermore, the *ex vivo* expression levels of B7-1 and B7-2 co-stimulatory molecules on monocytes/macrophages obtained from patients with a number of infectious disease have been shown to be significantly modulated. It is suggested that the expression levels of these molecules may impact development of disease progression. All these observations suggest the importance of B7-1 and B7-2 in the pathogenesis of infectious diseases and further investigations should lead to the design of new vaccines and immunosuppressive drugs for the treatment of these diseases.

Transplant rejection

It has been demonstrated that the B7-1 and B7-2 co-stimulatory molecules play a pivotal role in organ and bone marrow transplantation. The greatest risk involved in organ and bone marrow transplantation is graft versus host disease. Because transplant rejection is a T-cell dependent process, attempts have been made to block the CD28/B7 signaling pathway to inhibit organ graft rejection. There has been some success using the CTLA-4 Ig or a combination of anti-B7-1 and anti-B7-2 antibodies. But treatment with anti-B7-1 or anti-B7-2 antibodies alone, do not inhibit transplant rejection. For example, treatment with both anti-B7-1 and anti-B7-2 antibodies prolonged the acceptance of cardiac allografts in mice (63). In mice and rats, administration of CTLA-4 Ig prolonged the acceptance of cardiac allografts (64,65). In a xenogeneic islet transplant model, CTLA-4 Ig treatment has been successful in preventing human pancreatic islet cell rejection in mice (66). As well, it induced long-term donor-specific tolerance. These studies demonstrate that blocking the CD28/B7 co-stimulatory pathway can lead to transplant tolerance.

Expression and Regulation of B7-1 Expression by Cytokines and LPS

B7-1 was originally identified as a cell surface antigen expressed only on activated B cells following transformation with Epstein Barr Virus (EBV), or cross-linking of surface Ig receptors or MHC class II molecules (67-69). Subsequently, it was determined that B7-1 is expressed on activated T lymphocytes and activated APCs such as B lymphocytes, monocytes/macrophages, Langerhans cells, keratinocytes, and

dendritic cells (70-75). Activation of these cells can occur in a number of ways including MHC class II ligation, surface Ig cross-linking, CD40 ligation, cytokines (e.g. IL-2, IL-4, IFN- γ), and mitogens (e.g. LPS) (9,76).

Monocytes are professional phagocytes, which are capable of inducing adaptive immunity by presenting antigens to T cells. In general, monocyte activation in response to LPS results in the production of cytokines, such as TNF- α , IL-1, and IL-6, and other inflammatory mediators (77-79). This inflammatory response to LPS is an important contributor to septic shock, which may occur during infection with Gram-negative bacilli (80,81). Hence, up-regulation of B7 expression in monocytes mediated by LPS is thought to be important as a host defence mechanism against Gram-negative bacteria infection. Resting macrophages do not express B7-1 but treatment with IFN- γ leads to the expression of B7-1 (9,76). In freshly isolated human monocytes, B7-1 expression is up-regulated after stimulation with LPS, GM-CSF, or IFN- γ (9,30,76,82). Cross-linking of MHC class II molecules has also been shown to up-regulate B7-1 expression.

Resting T lymphocytes do not express B7-1, but upon LPS or IL-7 stimulation, activation by antigen or transformation by human T cell leukemia virus type-1 (HTLV-1), T cells can express B7-1 (9,83-85). Resting B cells also do not express B7-1, but upon stimulation with LPS, IL-4, or signalling through the surface receptors, CD40, or MHC class II, B7-1 expression is up-regulated (9,76,86,87). B7-1 has also been shown to be present on B cells following transformation by EBV, cross-linking of CD120b (p75, TNF-RII), or after treatment with cyclic AMP derivatives or dextran sulfate (9,76,86). When B lymphocytes are activated, B7-2 is rapidly expressed, followed by B7-1 24 to 48

hours later (87). Resting dendritic cells do not express B7-1, but do so when activated with GM-CSF (88).

Expression and Regulation of B7-2 Expression by Cytokines and LPS

Resting T lymphocytes express low levels of B7-2, but upon activation its level of expression increases (34). Resting B cells also express low levels of B7-2, but upon stimulation with IL-4, signaling through the surface Ig receptors, or crosslinking of MHC class II or CD40, B7-2 expression is enhanced (9,87). Resting dendritic cells do not express B7-2, but do so when activated with GM-CSF and IFN- γ (88).

B7-2 is constitutively expressed in human monocytes and is increased to higher levels upon treatment with IFN- γ , IL-4, GM-CSF, and cyclic AMP (82,89,90). Conversely, B7-2 expression in monocytes is down-regulated by LPS, TNF- α , and IL-10 (25,37,90,91). There is increasing evidence that the regulation of B7-1 and B7-2 in human monocytes is independent, as seen with different stimuli exclusively up-regulating or down-regulating B7-1 or B7-2 expression. For instance, cAMP induction has no effect on B7-1 but up-regulates B7-2 expression (89). And in the case of treatment with glucocorticoids, which are effective immunosuppressive drugs, B7-1 expression is inhibited but not B7-2 (89).

Signal Transduction

Cell signaling is critical in biological systems as it allows cells to communicate with one another leading to events such as cell growth and differentiation. In contrast, a

defect in the cell signaling pathways can result in autoimmune diseases and cancer. At present, very little is known about the signaling pathways regulating the expression of B7-1 and B7-2. Since my research proposal is focused on the signaling pathways, the following sections will discuss some of the presently known signal transduction mechanisms.

General Signaling Pathways

A paradigm for monocyte activation has been proposed in which entry into the cell cycle is caused by activation of phospholipase C (PLC) followed by the generation of the second messengers, inositol 1,4,5-triphosphates (IP₃) and diacylglycerol (DAG), that recruit intracellular systems triggered by increased intracellular Ca²⁺ and activation of protein kinase C (PKC), respectively (Fig. 1-3) (92). Ligand mediated cell signalling may be initiated at the cell surface by the direct activation of receptor protein kinases (PTK) (93). Cell signalling through the receptors that lack protein kinase domains involve cytoplasmic membrane associated nonreceptor PTK (93). Stimulation through cell surface receptors may also be mediated through either heterotrimeric or small Ras like GTP binding proteins (94). These rapid initial events may be linked to the several downstream signaling elements such as PLC- γ . Activation of PLC- γ by tyrosine phosphorylation leads to hydrolysis of phosphatidyl inositol (4,5)-biphosphate (IP₂), and the generation of the PKC activator, DAG and the endogenous Ca²⁺ mobilizing agent IP₃ (95,96). These second messengers activate Ca²⁺ and phospholipid dependent PKC as well as Ca²⁺ regulated protein kinases (95,96). Certain receptors may deliver signals through the activation of mitogen activated protein kinases (97,98). This pathway may

FIGURE 1-3: Generalized intracellular signaling pathways.

As shown, an extracellular signal molecule can bind and trigger membrane receptor tyrosine kinase to activate many parallel intracellular signaling pathways. Activation of phospholipase C (PLC) results in the further activation of 2 separate pathways, calcium-mediated pathway and protein kinase C (PKC). Signalling through the membrane receptor tyrosine kinase can also induce the activation of the MAPK and phosphatidylinositol 3-kinase pathways. Relaying of all of these signaling cascades lead to activation of gene regulatory proteins and their respective genes.

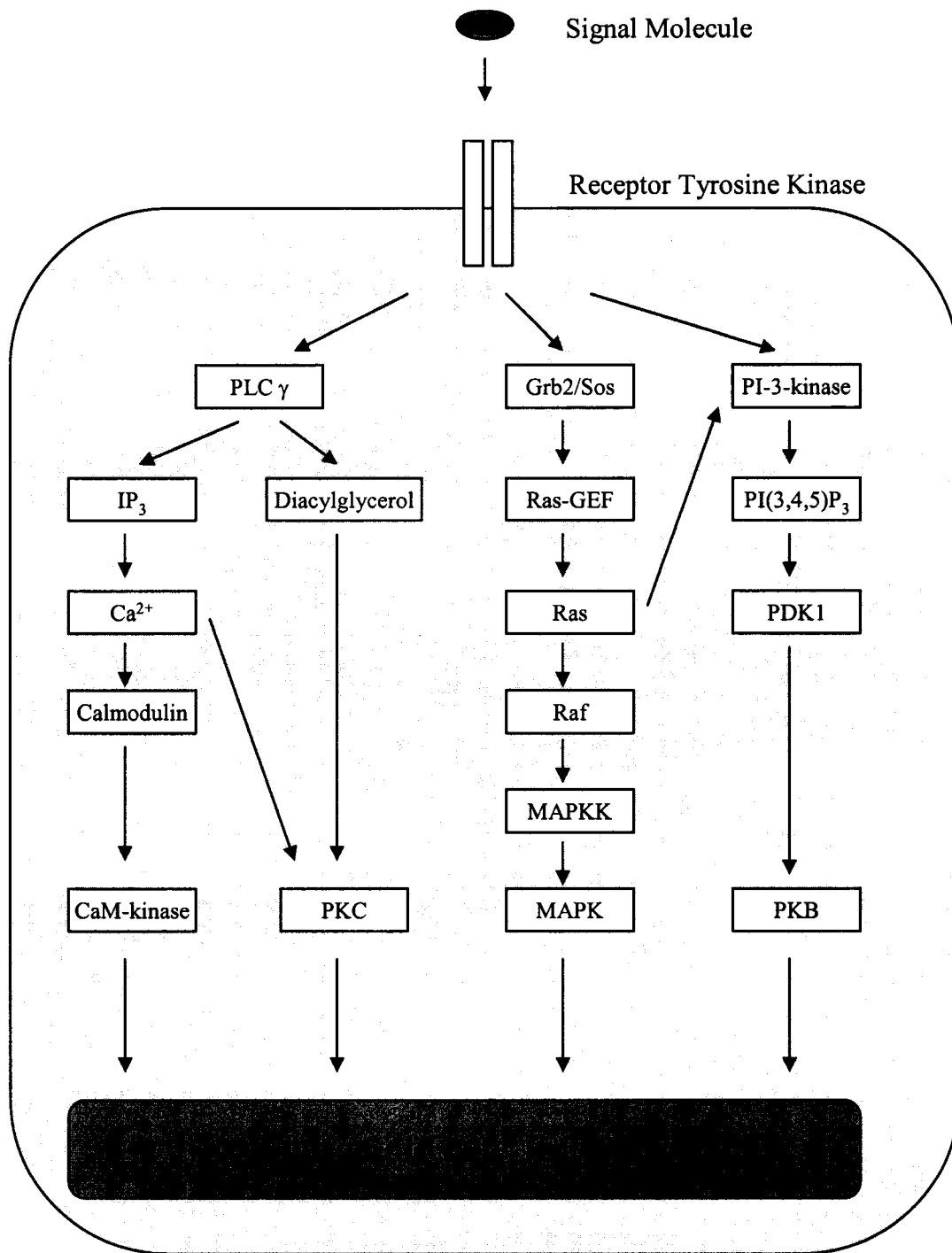

involve a cascade of events including activation of p21 Ras, Raf-1, MAP-ERK kinase (MEK) and the ribosomal S6 protein kinase (97,98). Activation of MAP kinase may also occur independently of p21 Ras via activation through MEK (97,98). The concept that rapid increase in the phosphorylation of macrophage proteins can provoke cellular responses is supported by studies in which treatment of cells with specific inhibitors of serine/threonine phosphoprotein phosphatases was sufficient to induce the production of IL-1 and TNF- α (99). Recently, LPS induced monocytic cell activation leading to cytokine production has also been shown to involve activation of specific protein tyrosine kinases including a CD14-associated *src* family, PTK, p53/56^{lyn}, p58^{lck} and p59^{fgf} (100). PKC has also been implicated in LPS-induced secretion of IL-1 (101). Translocation of PKC to the membrane fraction is considered to reflect enzyme activity. Treatment of monocytes with LPS induces the quantitative translocation of these enzyme activities to the membrane fraction. PKC inhibitors abrogate both the activation and translocation of PKC in these cells and attenuate LPS-induced secretion of IL-1 (101). Changes in the cytosolic concentration of Ca²⁺ are also a feature of macrophage activation. Exposure to agents that inhibit Ca²⁺ regulated protein kinases has been shown to abrogate changes in cell function (102). Cell signalling in macrophages also appears to involve activation of MAP kinases (103). Taken together, specific nonreceptor PTK, MAP kinases and other distinct kinases are integral components of signaling pathways that play a central role in cytokine regulation in monocytes/macrophages.

LPS-mediated signaling and TLR4

LPS is a potent mitogen capable of inducing the production of several proinflammatory and immunoregulatory cytokines, and regulating the expression of co-stimulatory molecules B7-1 and B7-2 in immune cells. During the last few years, attempts have been made to elucidate the molecular signaling pathways that induce cytokine expression in monocytes. However, the molecular signaling pathways involved in the regulation of B7-1 and B7-2 expression especially in LPS- and cytokine-stimulated monocytic cells remain to be investigated. Since I have been studying the regulation of LPS- and cytokine-induced regulation of B7-1 and B7-2 expression, I will provide a brief description of the molecular basis of signal transduction in LPS- and cytokine-induced regulation of B7 expression. Infection with Gram-negative bacilli results in the secretion of pro-inflammatory cytokines (TNF- α , IL-1, IL-6) followed by the anti-inflammatory cytokine IL-10 in monocytes/macrophages (77-79). The inflammatory response to LPS is an important contributor to adaptive immune responses and also to septic shock and generalized organ failure during an overwhelming bacterial infection (104). LPS or bacterial endotoxin is a glycolipid found in the outer cell wall of Gram-negative bacteria such as *E. coli*, *Neisseria*, and *Salmonella* (105). It consists of a core polysaccharide, o-antigen and lipid A (106). When LPS is initially released in the bloodstream, it interacts with serum derived LPS-binding protein (LBP) (105,107). The LPS-LPB complex then interacts with CD14 found on the surface of monocytes/macrophages (105,107). LPB is not absolutely required for LPS binding to CD14 but it facilitates its interaction. Subsequently, LPS binding to CD14 recruits an accessory protein MD2, which in turn binds to Toll-like receptor 4 (TLR4) a receptor expressed on antigen presenting cells

such as peripheral blood monocytes (105,107). Because CD14 is a glycosylphosphatidyl inositol (GPI)-anchored receptor lacking a transmembrane domain, it is not involved in transmitting a signal. In fact, studies with CD14-deficient mice demonstrated that they were responsive to high doses of LPS (108).

The signaling pathways mediated by TLR4 share some similarities with IL-1 receptor (IL-1R) signaling (109). Upon binding, TLR4 recruits the adapter protein MyD88 (110-112). MyD88 in turn recruits IL-1R-associated kinase (IRAK) to form a receptor complex. IRAK then binds with TNF-receptor-associated factor-6 (TRAF-6), which in turn binds to NF- κ B-inducing kinase (NIK). NIK activates the I- κ B kinase (IKK) complex. Subsequently, IKK activates NF- κ B by phosphorylating and degrading I- κ B and causing its release from the complex (110-112). Lastly, NF- κ B translocates into the nucleus and is involved in the transcriptional regulation of numerous genes (Fig. 1-4).

FIGURE 1-4: LPS-mediated signaling pathway on human monocytic cells.

Lipopolysaccharide (LPS) binding to monocytes/macrophages is mediated by CD14 receptor, LPS binding protein (LBP), Toll-like receptor 4, and accessory protein MD2. Signalling is transduced through TLR4, which activates the MAPK, NF- κ B, and PI-3 kinase pathways.

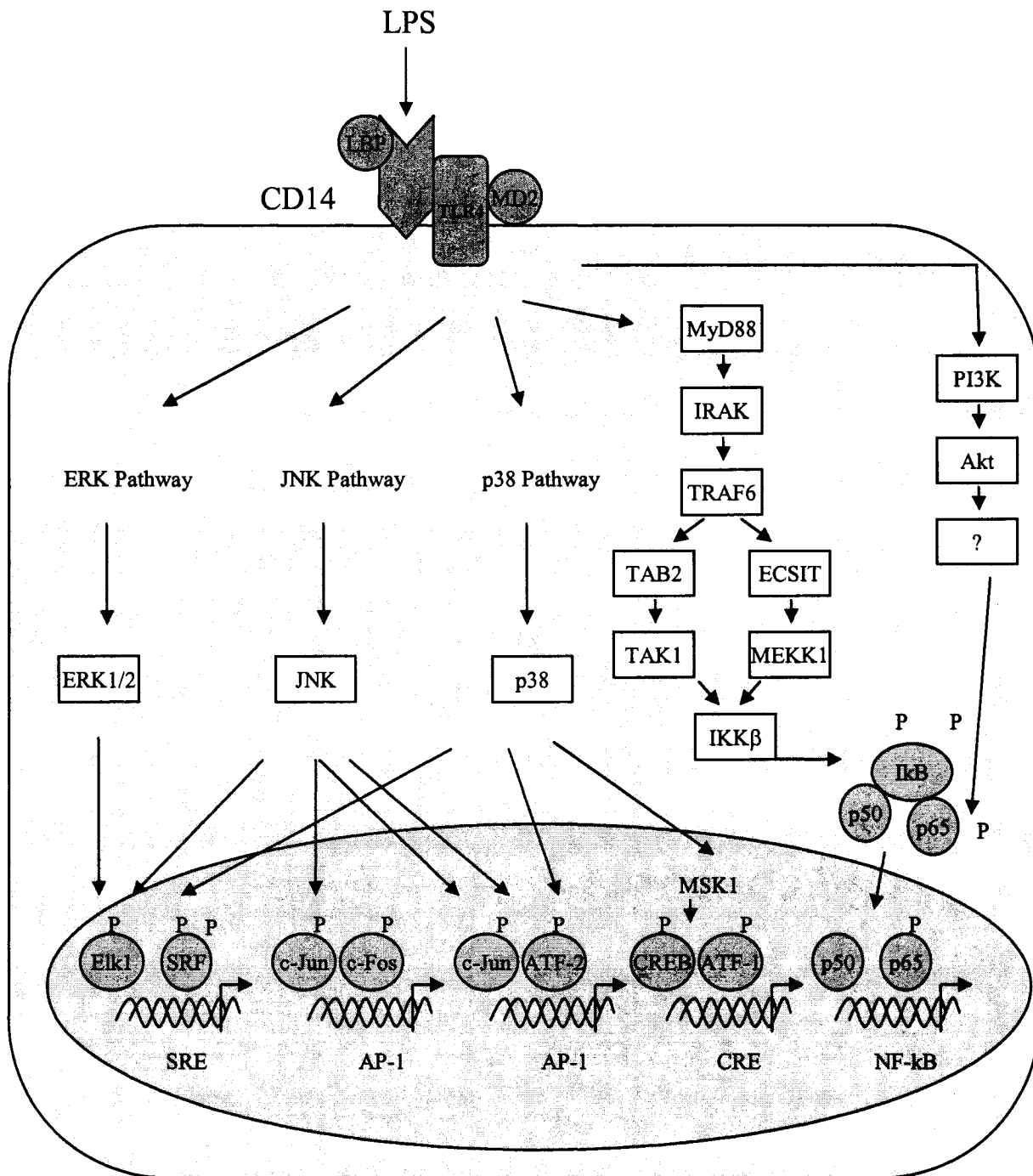

MAP kinase signaling

The mitogen-activated protein (MAP) kinases (MAPKs) are key players in cellular responses such as proliferation, differentiation, and apoptosis. The three main families of MAP kinases are the extracellular signal-regulated protein kinases (ERK1 and ERK2), the c-Jun NH₂-terminal kinases (JNKs), and the p38 MAP/stress-activated protein kinases (p38 MAPK/SAPKs) (Fig. 1-5) (113). Essentially, extracellular signals trigger receptors at the cell surface, which transmits a signal to activate the MAPK cascades. This results in phosphorylation of a variety of regulatory proteins, such as other protein kinases and transcription factors. ERKs respond to mitogens and growth factors that regulate cell proliferation and differentiation; whereas JNK and p38 MAP kinases are predominantly activated by stress and inflammatory cytokines (IL-1 β and TNF- α) (113). All three MAP kinases consist of a modular three kinase cascade in which MAPK are activated by dual phosphorylation at their Thr-X-Tyr motif by MAP kinase kinases (MAPKKs or MEKs) (114). Specifically, ERK is phosphorylated at the Thr-Glu-Tyr motif, JNK at Thr-Pro-Tyr, and p38 at Thr-Gly-Tyr (114). And in turn, MAPKKs are activated by the MAP kinase kinase kinases (MAPKKKs or MEKKs) (114).

Among the three MAP kinases, the signaling pathways for the ERK1 (p44) and ERK2 (p42) are the best characterized. Extracellular signals such as mitogens and growth factors bind to the receptor protein tyrosine kinase receptors on the cell surface triggering receptor autophosphorylation and activation. This results in the binding of the adaptor protein Grb2 via its Src homology 2 (SH2) domains, with the cytoplasmic domain of the autophosphorylated receptors (115,116). The SH3 domain of Grb2 then associates with the proline-rich region of the guanine nucleotide-exchange protein, son

FIGURE 1-5: MAP kinase pathways.

The MAPK signaling cascade consist of the stress activated p38 and c-Jun NH₂-terminal kinases and the mitogen-activated ERK1/2(p42/44) pathway. Chemical inhibitors and dominant negative mutant plasmid that were employed to specifically block each pathway are highlighted in blue.

p38 MAP Kinase Pathway

ERK MAP Kinase Pathway

JNK MAP Kinase Pathway

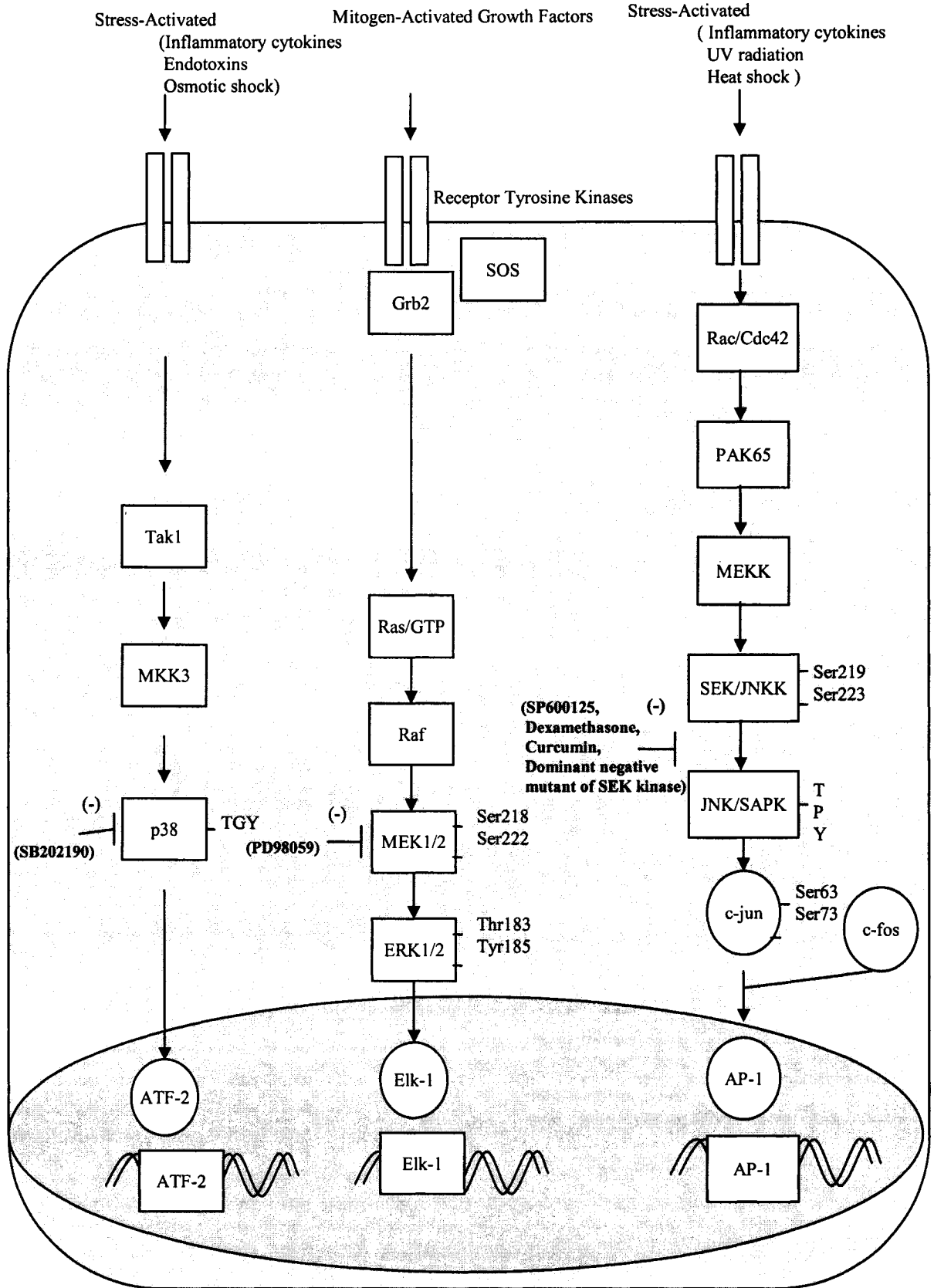

of sevenless (SOS) (115-117). They in turn, activate Ras by exchanging GTP for GDP. And activated Ras binds to the proto-oncogenic Raf (MAPKKK) causing Ras to anchor itself to the cell membrane (115-117). The Raf family which consist of c-Raf1, B-Raf, and A-Raf, then phosphorylates and activates the MAPKKs, MKK1(MEK1) and MKK2(MEK2) which then activates and phosphorylates ERK1 and ERK2 (115-117). Upon activation, ERK1 and ERK2 can translocate into the nucleus and phosphorylate kinases such as P90 ribosomal S6 kinase and mitogen and stress-activated kinases, and transcription factors such as Elk-1 and Stat3 (115-117).

The JNKs were discovered as stress-activated protein kinases and that were able to phosphorylate and activate the c-Jun transcription factor (118,119). Since c-Jun along with c-fos form the AP-1 transcription factor complex, it is essential in the expression of many cytokine genes (120). JNK is activated by various stress responses including ultraviolet light radiation, heat shock, osmotic shock, and growth factors. The JNK family members consist of JNK1, JNK2, and JNK3 (120). JNK1 and JNK2 are widely expressed, whereas JNK3 is expressed mainly in the brain. The regulation of JNK is more complex and less understood than the ERK signaling pathway. But it has been demonstrated that upstream components such as the small GTP-binding proteins Rac and Cdc42 (Rho family GTPases), and STE20-related p21-activated kinases (PAKs) are involved in the activation of JNKs (121-123). And it is known that both dual-specific kinases MKK4 and MKK7 phosphorylate and activate JNK at the Thre183-Pro-Tyr185 residue (120).

The p38 MAPK is also activated by a variety of stimuli including inflammatory cytokines (tumor necrosis factor and IL-1), endotoxins, hormones, ligands for G protein-

coupled receptors, osmotic shock, ultraviolet light radiation, and heat shock (124-126). Activation of the p38 MAPKs is crucial in the expression of inflammatory cytokines such as IL-10 (127). The p38 MAPK family consist of p38 α , p38 β , p38 γ , and p38 δ . Among the four kinases, the p38 α kinase is the best characterized and known to be activated by TAB1 (128). It has also been established that p38 MAPKs is activated by MKK3 and MKK6 (126,129). MKK3 activates p38 α , p38 γ , and p38 δ , while MKK6 activates all 4 p38 MAPK isoforms (126,130). Upon activation, p38 translocates into the nucleus and activates transcription factors such as the CREB family member ATF-2.

Further complexity of the MAPK signal transduction pathway is added by cross-talk between the signaling cascades. For instance, MKK4, which activates JNK, can also activate p38 α (129,131). LPS has been shown to activate all three types of MAP kinases (101), but there is little information on the role of these kinases in general in monocytes and particularly in B7 expression.

Anti-inflammatory cytokine IL-10 and its biological functions

LPS acting on several pro- and anti-inflammatory cytokines such as interleukin 10 (IL-10) may regulate the activity of Th1 cytokines and B7 co-stimulatory molecules. Therefore, LPS-induced regulation of B7 molecules may be mediated by cytokines such as IL-10. Interleukin 10 is a pleiotropic cytokine produced by many types of cells including monocytes, B cells, CD8⁺ T cells, regulatory T cells, CD4⁺ Th0, and Th2 cells (132-134). It is able to exert anti-inflammatory responses by suppressing the production of cytokines such as IL-1, IL-6, IL-8, IL-12, TNF α , and granulocyte-macrophage colony stimulating factor, and MHC class II molecules and B7 in monocytes/macrophages (135-

137). As well, through suppression of IL-2 and IFN- γ , IL-10 is able to diminish Th1 activity (136,138).

IL-10 inhibits the antigen-driven activity of both Th1 and Th2 subsets, and hence is not strictly a Th2 type cytokine, although it facilitates the induction of Th2 cells types (133,137). IL-10 has been shown to down-regulate the release of oxygen and nitrogen intermediates, as well as TNF- α , resulting in macrophage deactivation which may allow the growth of tumor cells and intracellular microbes (137,139). The potent inhibitory action of IL-10 on macrophages, particularly at the level of cytokine production, supports an important role for IL-10 in the regulation of T cell responses and acute inflammatory responses (137). In addition, IL-10 has been shown to stimulate a variety of biological functions such as costimulation of thymocyte growth in the presence of IL-2 and/or IL-4, and B cell growth and differentiation (132,137,140). Naïve IgD+B cells, when activated with anti-CD40 antibodies, secrete IgG1 and IgG3 in the presence of IL-10, indicating a critical role for IL-10 in isotype switching and B cell differentiation (132,141). Furthermore, IL-10 acts as an autocrine growth factor for Ly-1+ B cells, which are important in murine models of autoimmune disease (142).

The molecular mechanism underlying IL-10-mediated inhibitory effects has been studied in a number of model systems. IL-10 interacts with a single high affinity receptor complex expressed on most hematopoietic cell types (136,143). The IL-10R is composed of two subunits, IL-10R1, the ligand binding subunit, and IL-10R2, the accessory subunit (136,143). Engagement of the IL-10R complex activates the well characterized JAK-STAT signaling pathway. Janus Kinase-1 (Jak1) and Tyk2 tyrosine kinases are constitutively associated with IL-10R1 and IL-10R2, respectively (136,144). IL-10

induces tyrosine phosphorylation and activation of the latent transcription factors STAT-3 and STAT-1, and in non-macrophage cells STAT-5 (144,145). STAT-3 is recruited directly to the IL-10R complex via either of two tyrosine residues present in the IL-10R1 cytoplasmic domain (144). Dimers of phosphorylated STAT-3 molecules translocate to the nucleus resulting in gene expression. IL-10 mediates its inhibitory effects on macrophage proliferation and TNF- α production through STAT-3 activation (143,144). Recently, IL-10 has been shown to increase the expression of the cyclin-dependent kinase inhibitor p19^{INK4D} in macrophages. The expression of p19^{INK4D} was later shown to be dependent on the activation of STAT-3 (146,147). The inhibitory effects of IL-10 have also been shown to involve the activation of the suppressor of cytokine signaling (SOCS) proteins, in particular SOCS1 and SOCS3, in response to LPS and IFN- γ stimulation in monocytic cells (148,149). The induction of SOCS3 gene has been attributed to STAT-3 activation (150) indicating that STAT-3 constitutes an important component of the mechanism by which IL-10 exerts its inhibitory effects. In contrast to STAT-3, the role of STAT-1 in the regulation of IL-10-mediated biological effects is not known. Macrophages from STAT-1 knockout mice remain responsive to IL-10 (151), and dominant negative STAT-1 does not block IL-10-mediated effects in monocytic cells (147).

Recently, we have demonstrated that the stimulatory effects of IL-10 on CD14 expression maybe be mediated by STAT-1 in human monocytic cells (152). IL-10 has also been shown to regulate cytokine production by monocytic cells through signaling pathways other than JAK/STAT. For example, IL-10 has also been shown to induce the activation of phosphoinositol 3'-kinase (PI3-kinase) possibly through JAK-1 activation

(153,154). There is evidence to suggest that JAK-1 tyrosine phosphorylates the insulin receptor substrate-1 (IRS-1) docking molecule following interaction of IL-2, IL-4, IL-10 and IFN α with their corresponding receptors (154,155). Subsequently, tyrosine phosphorylated IRS-1 proteins may recruit the regulatory p85 subunit of PI3-kinase to the plasma membrane through phospho-tyrosine-SH2 domains interaction (156). It was reported that specific inhibitors of PI3-kinase inhibited the proliferation but not the anti-inflammatory activities of IL-10 (153). Recently, IL-10 has also been shown to enhance the survival of astrocytes through the activation of PI3-kinase (157). In addition to PI3-kinase, there is evidence to suggest that IL-10 can induce the activation of p38 and ERK MAPKs (91,158,159). However, the role of MAPK in IL-10 mediated effects is also not clear at present. ERK MAPK has been shown to be involved in the regulation of CD14 expression in human monocytic cells in response to IL-10 (152). Further studies are needed to precisely dissect the role of ERK in IL-10 mediated biological effects.

B7-1 Gene Regulation and Transcription Factors

Transcription is the enzymatic process in which genetic information is transferred from a strand of DNA to mRNA by RNA polymerases. This is a highly regulated process in which the level of transcriptional activation of a gene depends upon the binding of regulatory factors to specific recognition sequences in the promoter. There are numerous regulatory regions on the promoter of a gene that bind to a variety of transcription factors. In fact, different combinations of transcription factors can differentially regulate gene expression. And because each type of cell expresses its own

unique combination of transcription factors, this determines cell-type specificity during gene expression.

Though the nucleotide sequence for the human B7-1 promoter region, (GenBankTM accession number U33208) has been previously characterized (160), the transcriptional control of B7-1 gene is not well defined (Fig. 1-6). Based on computer software programs that can predict potential transcription factor binding sites, a number of potential regulatory elements can be found on the human B7-1 promoter. These include three sites for nonspecific *trans*-activating factors AP2, three SP1 sites, an E2 site, a CREB (single cyclic AMP-responsive element) site, and an AP1 site. Zhao, et al., were the first group to isolate, clone and sequence the human B7-1 promoter, which contained approximately 14 kb upstream from the first exon (160). By employing DNase I hypersensitivity assays on various cultured cells lines, they found a cell type-specific 183 bp enhancer region 3 kb upstream of the transcription initiation site that was responsive to LPS and dibutyryl cAMP in Raji B cells. This was consistent with the fact that both LPS and dibutyryl cAMP are known to increase the expression of B7-1 cell surface molecule in B cells. To further characterize the 183 bp enhancer region, they generated deletion and site-directed mutant constructs, transfected the constructs into Raji B cells and measured their CAT activities. The 183 bp enhancer region was determined to contain multiple *cis* elements including an NF- κ B binding site. Electrophoretic mobility shift assays (EMSAs) performed on nuclear extracts of Raji B cells further confirmed that this was indeed an NF- κ B binding site (160).

Subsequently, another group led by Fong et al. also characterized the regulatory elements of the human B7-1 promoter and found that it did not contain the canonical

FIGURE 1-6: Human B7-1 promoter.

The nucleotide sequences of the B7-1 promoter are provided in the diagram. The +1 denotes the transcriptional start site and the underlined sequences identify the putative regulatory elements.

B7-1 PROMOTER

-600	ACAGGGGCTC	CAGAATCCTA	CAAAGGGACA	CACAGGGGTG	GGTGGCAACT
-550	AGTTGGAAAT	GGGAGTGATG	GGCATGACTA	AAGTCTTCCT	CATCCCACCA
-500	GAGGCGCACT	CAACTGTGGC	TAGGGTGACC	AGAATTCACT	GTCCAGCGTG
		AP2		SP1	
-450	GCTGGCAGGA	<u>GCCCACTCTC</u>	TGAAGATGGT	GGGATTCAGA	<u>GGTGGGAGTA</u>
		SP1			
-400	GAGTTGGGTG	<u>GTCTTGTGAG</u>	CTGAGCACTC	TCCCAAAGT	GTCCCCTACA
			AP2		
-350	TATGAGGTG	ACAGCTTATT	<u>CCTGCAGGGA</u>	CTCAGGAGTA	ACTCTGGGTG
				SP1	
-300	CTAAACAAA	ACTTGAGACC	AGCACAGAAA	<u>CAGCCAGCCC</u>	<u>ATGAAGCTGG</u>
-250	CCTCCCATCA	CACAGCAAGG	CTAGCCAGAT	GCCCCTCACT	CTTCTCGGGC
-200	ACCATTC TTC	TCCTCCCCTA	GGCCGCCTGG	TGCTCGTGGT	GTTTCATGTT
	E2				AP2
-150	TGTTAGTCCA	<u>TGCACGGTGG</u>	TGAGGGAGGC	TGCTGTGTGA	<u>TTTGCCCCAG</u>
		IRF-7		CREB	B7-RE
-100	<u>CCACAGCCTC</u>	<u>TACAAAAGCA</u>	<u>AGTAGAAGAA</u>	<u>GACGGCAGCA</u>	<u>GAGGGCGCTT</u>
				AP1	
-50	<u>CTTCAAACAC</u>	<u>CCTGTCCAAC</u>	<u>TCCTGGCACT</u>	<u>GACAAGTACT</u>	<u>GAGTGA ACTC</u>
+1	AAACCCTCTG	TAAAGTAACA	GAAGTTAGAA	GGGAAATGT	CGCCTCTCTG

TATA- and CAAT-boxes (161). As well, it did not contain GC-rich motifs that would be normally found in TATA-less genes of the “housekeeping” class. Through DNase I footprinting analysis and B7-1 promoter activity studies using deletion and site-directed mutant constructs, they identified a region -60 to -47 from the transcription start site, that they termed this region B7-regulatory element (B7-RE). This region was critical for the basal expression of B7-1 in Raji B cells (161). From the results of the EMSA studies, this B7-RE site appears to share some sequence similarity with the consensus NF- κ B motif (161). But they were unable to fully determine what transcription factors bind to the B7-RE site. In a similar work, a series of human B7-1 promoter deletion constructs were transiently transfected into keratinocytes (162). Subsequently, it was determined that allergens and irritants were capable of transcriptionally up-regulating B7-1 promoter activity, and particularly important was a region 231 bp upstream of the transcription start site (162).

The mouse B7-1 promoter has also been investigated. The genomic organization of the mouse B7-1 gene and the location of the transcription start site was first determined by Selvakumar and his group (163). Subsequently, the mouse B7-1 promoter was characterized and found to contain an enhancer element between the regions from –597 to –588 relative to the transcription start site (164,165). As well, another group mapped a number of positive regulatory regions on the mouse B7-1 promoter spanning from –3957 to –1555, -130 to –110, and +25 to +269 (166).

B7-2 gene regulation and transcription factors

Realizing that IFN- γ can up-regulate B7-2 expression on monocytes, Suci-Foca et al. sought to determine how IFN- γ can regulate B7-2 at a transcriptional level (167). They accomplished this by cloning and sequencing the human B7-2 gene and submitting the 1277 bp sequence containing the human B7-2 promoter to the GenebankTM (accession AF099105). Through primer extension assay they also mapped the transcription initiation site of the B7-2 gene (Fig. 1-7). To characterize the B7-2 promoter, a series of deletion and mutant promoter constructs fused to a luciferase reporter gene were generated and transiently transfected into U937 monocytic cells (167). They were able to determine that IFN- γ was able to induce B7-2 expression in U937 cells through two IFN- γ activating sites (GAS). EMSA and supershift assays identified Stat1- α as the transcription factor which binds to the GAS elements (167).

It is known that CD8⁺ CD28⁻ T suppressor lymphocytes (Ts) inhibit activation and proliferation of Th cells by down-regulating B7-1 and B7-2 expression in antigen presenting cells (168,169). Therefore, Suci-Foca's group wanted to investigate the mechanism by which Ts cells transcriptionally regulate B7-2 in B cells (170). Using the Transfat program for identifying transcription factor binding sites, they first identified two NF-kB binding sites, -612 and -238 from the transcription start site (Fig. 1-7). B7-2 promoter and mutant studies indicated that the NF-kB element at -612 was necessary for Th-induced transcription and that Ts cells inhibited NF-kB mediated transcription of B7-2 in normal human B cells (170).

Recently, it was determined that lauric acid can transcriptionally activate the B7-2 promoter and it is mediated through TLR4 (171). The murine macrophage cell line

FIGURE 1-7: Human B7-2 promoter.

The nucleotide sequences of the B7-2 promoter are provided in the diagram. The +1 denotes the transcriptional start site and the underlined sequences identify the putative regulatory elements.

B7-2 PROMOTER

-650 tagtttctgc ttgattaatt ctatgtttgt ctcttaggga catctattaa NF-κB

-600 ttttataatg ctgccttttt ttcagacttc tgtttcagaa tattegcctt

-550 catgaatgta atccttggct atagtaggaa tgaaataata aaagcagtag

-500 cttctgtctg cctccttgg ttatgcagtc cttacagaca ttctccccac

-450 ctcccatccc cccaccccag ctcagtgaaa ctctccacac tttggttgtg

-400 gaaattggca gggtaggtg gctactcact cccaatccac atccacaata

-350 aatcactttt tattatctta tcaaaatctg tagaatgcct ctttattcta

-300 ttttgttgc gcgagggtt gttttctctt totaattatt ttattttcta

-250 ggtttttga gggaatttca agaggggaga tttttattc aggctcatct NF-κB

-200 taacgtcatg tctggaactc aagctactga attatatatt ctttaataca

-150 tatagaccta cgtcaatgag tttaaactgc aaggaaaggg ttaaatttct CREB

-100 tcctcaagtg tggcctaaaat ctgtagagaa aagaggaaca gcttctctta IRF-2

-50 aagaaagtta gctgggtagg tatacagtca ttgccgagga aggcttgac

+1 agggtgaaag ctttgcttct ctgctgctgt aacagggact agcacagaca

+50 cacggatgag tggggtcatt tccagatatt aggtcacagc agaagcagcc

+100 aaaatggatc cccagtg

RAW264.7 was transfected with a B7-2 promoter/luciferase reporter gene construct spanning from -1247 to +45 relative to the transcription start site. Upon stimulation with the saturated fatty acid, lauric acid, B7-2 promoter activity was up-regulated. Co-transfection of either plasmids expressing dominant negative mutant TLR4, I κ B α , or IRF-3 inhibited lauric acid-induced B7-2 expression. TLR4 is known to activate the MyD88-dependent pathway and the MyD88-independent pathway. Signaling through the MyD88-dependent pathway leads to NF- κ B and MAPK activation, whereas the MyD88-independent pathway leads to activation of IRF-3 and delayed NF- κ B activation. Hence, these results indicate that lauric acid induces B7-2 expression through TLR4 and the MyD88-independent pathway (171). Apart from the aforementioned published works, no other information on the characterization of B7-1 and B7-2 promoter elements are available.

RATIONALE AND HYPOTHESIS

The differential expression of the B7-1 and B7-2 co-stimulatory molecules on various cells and with different kinetics suggests that the B7-1 and B7-2 ligands may play unique roles in modulating an immune response. Also, B7-1 and B7-2 may not deliver identical co-stimulatory signals, since B7-2 but not B7-1 preferentially co-stimulates the initial production of IL-4. Thus, B7-1 and B7-2 may play an important but separate role in Th1/Th2 cell differentiation. Whether B7-1 and B7-2 have distinct or overlapping functions remain unresolved and need to be clarified.

Alterations in the levels of B7 expression on monocytes by endotoxins and immunoregulatory cytokines may have profound effects on the development of immune

responses. The molecular mechanisms in the regulation of the B7-1 and B7-2 co-stimulatory molecules by LPS are presently not well understood. Regulation of B7-1 and B7-2 co-stimulatory molecules in human monocytic cells may be mediated by distinct signaling pathways and transcription factors. The overall objective of my research project was to dissect the signaling pathways and the transcription factors involved in the regulation of B7-1 and B7-2 expression in LPS-stimulated human monocytic cells. My results should provide a complete picture on the regulation of B7-1 and B7-2 co-stimulatory molecules by LPS in the hopes of discovering potential immunomodulatory targets. Therefore, understanding B7 regulation and characterizing the signal transduction and molecular events involved may lead to the development of strategies for the treatment of autoimmune diseases, infections and cancer.

The specific research objectives are as follows:

- 1) To dissect the MAP kinase signal transduction pathway for B7-1 expression, identify the regulatory elements on the B7-1 promoter, and characterize the transcription factors which regulate the B7-1 promoter in human monocytic cells.

- 2) To elucidate the MAP kinase signal pathway for B7-2 expression, identify the regulatory elements on the B7-2 promoter, and determine the transcription factors which regulate the B7-2 promoter in human monocytic cells.

CHAPTER 2:
MATERIALS AND METHODS

Cell lines and cell culture

THP-1, a promonocytic cell line derived from a human acute monocytic leukemia patient was obtained from the American Type Culture Collection (ATCC) (Rockville, MD). THP-1 cells stably transfected with a plasmid containing CD14 cDNA sequences (THP-1/CD14) were kindly provided by Dr. Richard Ulevitch (The Scripps Research Institute, La Jolla, CA). All cells were cultured in Iscove's Modified Dulbecco's Medium (IMDM, Sigma Chemical Company, St. Louis, MO) and were supplemented with 10% heat-inactivated fetal bovine serum (FBS, GIBCO Laboratories, Grand Island, NY), 100 U/mL penicillin, 100 µg/mL gentamicin, 10 mM HEPES, and 2 mM glutamine. The cells were cultured in a T-75 cm² flask (Nunc, Roskilde, Denmark) at 37°C in a 5% CO₂ incubator. Periodically upon reaching confluency of approximately 1x10⁶ cells/ml, the cells were split into new T-75 cm² flasks containing fresh IMDM media. To ensure that cells used did not undergo too many passages, cells were frozen in 10% DMSO in cryovials, kept in liquid nitrogen storage and thawed when required.

Reagents

PD98059, a MEK-1 inhibitor which selectively blocks the activity of ERK MAP kinases and not other serine-threonine protein kinases was purchased from Calbiochem (San Diego, CA) (116,172). The pyridinyl imidazole SB202190, a potent and specific inhibitor of p38 MAP kinase without any effect on ERK or JNK MAPK activity, was also purchased from Calbiochem (116,124). SP600125, a specific JNK inhibitor (BIOMOL, Plymouth Meeting PA), is a reversible ATP competitive inhibitor with more than 300 fold selectivity versus ERK1 and p38 MAPKs (173). Lipopolysaccharide derived from

E. coli 0111:B4 (Sigma, St. Louis, MO), dexamethasone (DXM, 9 α -Fluoro-16 α -methylprednisolone, Sabex Inc., Boucherville, Quebec, Canada), curcumin (Calbiochem), human recombinant IL-10 (R&D Systems, Minneapolis, MN), neutralizing anti-IL-10 and isotype-matched control antibodies (Pharmingen, Mississauga, Ontario, Canada) and Protein-A Sepharose (Pharmacia, Baie d'Urf 130, Quebec, Canada) were also purchased. All other chemicals used for immunoblot and electrophoresis analysis were obtained from Sigma-Aldrich.

Isolation of monocytes from peripheral blood mononuclear cells

Peripheral blood mononuclear cells (PBMCs) were isolated from the blood of healthy adult volunteers after approval of the protocol by the ethics review committee of Children's Hospital of Eastern Ontario. Blood from the healthy adults were intravenously drawn and transferred into BD Vacutainers® blood collection tubes (Becton-Dickinson, Rutherford, NJ) containing the anti-coagulant sodium heparin. PBMCs were then isolated by density gradient centrifugation over Ficoll-Hypaque (Pharmacia, Uppsala, Sweden) (134). This was accomplished by layering the blood carefully onto Ficoll-Hypaque in a 15 ml sterile BD Falcon™ centrifuge tube (Becton Dickinson), and spinning at 1600 rpm for 30 minutes without brakes. The buffy coat cell layer containing the mononuclear cells was collected using a sterile plastic pipette and transferred into a new sterile centrifuge tube. The PBMCs were then washed three times in phosphate buffered saline (PBS, Sigma) and centrifuged at 1600 rpm for 5 minutes. The total number of PBMCs obtained were determined by counting under a hemacytometer and a light microscope.

Purified monocytes were isolated from these cells by negative selection by depletion of T cells and B cells using magnetic polystyrene Dynabeads coated with antibodies specific for CD2 (T cells) and CD19 (B cells) (Dynal, Oslo, Norway). Prior to use, the Dynabeads were washed repeatedly with PBS/2%FBS to remove all traces of the sodium azide preservative. Briefly, PBMCs ($10\text{-}20 \times 10^6$ cells/ml) were resuspended with Dynabeads M-450 Pan-T (CD2) and Pan-B (CD19) for 30 minutes on ice with constant rocking. CD2⁺CD19⁺ cells were separated magnetically from the CD2⁻CD19⁻ cells using a magnetic particle concentrator (Dynal). CD2⁻CD19⁻ cells were incubated on a 12 well plate at 37°C for 2 hours following which non-adherent cells were removed. The adherent mononuclear cells contained fewer than 1% CD2⁺ T cells and CD19⁺ B cells as determined by flow cytometric analysis.

Monocytic cell stimulation

To determine the effect of MAPK inhibitors on B7-1 and B7-2 expression, monocytes (0.5×10^6 cells/ml), THP-1 (1×10^6 cells/ml), and THP-1/CD14 cells (1×10^6 cells/ml) were incubated with various concentrations of inhibitors specific for ERK, p38, or JNK MAPKs for 2 hrs followed by stimulation with 1 µg/ml of LPS or 10 ng/ml IL-10 in 24 well culture plates (Falcon, Becton-Dickinson, Frankland Lakes, NJ) for 0-15 minutes for western blot analysis and 24 hours for analysis of B7-1 expression by flow cytometry. The cells were stimulated with LPS for 48 hours prior to analysis by flow cytometry for B7-2 expression. Cell supernatants were collected and frozen at -80°C and were later thawed and analyzed by ELISA for IL-10 production.

Measurement of IL-10 cytokine production by ELISA

IL-10 cytokine secretion from the monocytes were measured using sandwich enzyme-linked immunosorbent assay (ELISA) and with two different monoclonal antibodies (mAbs) which recognize distinct epitopes (174). Briefly, the 96 well plates (Nunc Immunomodules, Roskilde, Denmark) were coated overnight at 4°C with 5 µg/mL of the primary or capture anti-IL-10 monoclonal antibody (Pharmingen, #18551D) in a coating buffer (0.1 M NaHCO₃, pH 8.2). The plates were washed three times with PBS containing Tween 20, and blocked with PBS containing 10% FBS for two hours. After blocking, the plates were once again washed three times with PBS containing Tween 20. 4 µg/mL of a second, biotinylated anti-IL-10 mAb (Pharmingen, #18562D) were added to the plates and left to incubate for 1 hour. Streptavidin-peroxidase was used at a final dilution of 1:1000 (Jackson Immuno Research, West Grove, PA) and added to the plates. The color reaction was developed by *O*-phenylenediamine (OPD, Sigma-Aldrich) and hydrogen peroxide and the absorbance was read at 450 nm using a standard ELISA plate reader. Recombinant IL-10 (Pharmingen) was used as a standard and IL-10 concentrations were automatically calculated using the Microplate Manager 4.0 Software (Bio-Rad Laboratories, Hercules, CA).

Flow Cytometry

B7-1 and B7-2 expression on CD14⁺ monocytes, THP-1, THP-1/CD14 cells were determined by flow cytometric analysis (175). Approximately 0.5 x 10⁶ cells were washed once with PBS/0.1% sodium azide in a polystyrene tube (Falcon, Lincoln Park, NJ). After centrifugation at 1600 rpm for 5 minutes and removal of the supernatant, the

cells were stained with 3 μ l of FITC-labeled anti-CD14 mAbs (Becton Dickinson Immunocytometry Systems, San Jose, CA) and 3 μ l of R-PE-labelled anti-B7-1 or anti-B7-2 mAbs (BD Biosciences-Pharmingen, Mississauga) for 30 minutes at room temperature in the dark. After staining, the cells were washed once with PBS/0.1% sodium azide and centrifuged at 1600 rpm for 5 minutes. For analysis of monocytes, CD14⁺ cells were gated accordingly. Approximately 10,000 events were collected for the THP-1 and THP-1/CD14 cells, and 50,000 events for the purified monocytes during analysis. Autofluorescence and isotype matched control antibodies, IgG1 κ (BD Biosciences), were also included. Data were acquired on a Becton Dickinson FACScan Flow Cytometer and analyzed using the WinMDI version 2.8 software package (J. Trotter, Scripps Institute, San Diego, CA).

Cell Viability Assay

Cell viability of THP-1/CD14 cells after treatment with signaling inhibitors were determined by staining with propidium iodide (Sigma) and subsequent flow cytometric analysis. THP-1/CD14 (0.5×10^6) cells were pretreated with various doses of the MAP kinase inhibitors for 2 hrs followed by treatment with 1 μ g/ml of LPS for 24 hrs. Following treatment, the cells were harvested, pelleted, and washed with PBS/0.1% sodium azide as described above. The THP-1/CD14 cells were then stained with 1 μ g/ml of propidium iodide for 15 minutes at room temperature followed by flow cytometric analysis.

Western Blot Analysis

Phosphorylation of p38, p42/44 ERK, and JNK MAPKs was determined by Western blot analysis using phospho-MAPK-specific antibodies. For Western blots, lysates were prepared and the proteins separated by SDS-PAGE. Cells were stimulated at 37°C for 0 to 15 minutes with LPS or IL-10, and immediately harvested by washing with cold PBS and centrifugation at 12,000 x g at 4°C for 5 minutes. The cell lysates were prepared by resuspending the cell pellet containing 5 to 10 x 10⁶ cells in lysis buffer (PBS containing 50 mM HEPES, 10% glycerol, 1.5 mM MgCl₂, 1 mM EGTA, 100 mM NaF, 1% Triton X-100, 1 mM Na₃VO₄, 25 µg/ml leupeptin, and 25 µg/ml aprotinin) at 4°C for 45 min followed by centrifugation at 10,000 rpm at 4°C for 20 min. Total protein concentration of the cell lysates was determined by using the Bradford protein assay kit (Bio-Rad) and bovine serum albumin (BSA, Sigma-Aldrich) as a standard. Equal amounts of proteins (50 µg) were treated with β-mercaptoethanol and, boiled for 5 minutes and placed on ice to denature and unfold the proteins. Using a slab gel electrophoresis apparatus (BioRad), a prestained molecular weight marker (BioRad) and the protein samples were subjected to 10% sodium dodecyl sulfate-polyacrylamide gel electrophoresis (SDS-PAGE). The proteins were transferred from the gel onto polyvinylidene difluoride membranes (Pall Corporation, Ann Arbor, MI) using a wet transfer blotting cell apparatus (BioRad). The membranes were washed and blocked with skim milk and probed with either rabbit anti-phospho-p38, mouse anti-phospho-p42/44 or rabbit anti-phospho-JNK mAb according to the manufacturer's specifications (Santa Cruz Biotechnologies, Inc., Santa Cruz, CA). After further washing of the immunoblots, horseradish peroxidase conjugated goat anti-rabbit or goat anti-mouse polyclonal

antibodies (BioRad) were added. Finally, the immunoblots were visualized by enhanced chemiluminescence (ECL, Amersham, Baie d'Urfe, PQ, Quebec) on an X-ray film (Kodak). To ensure that the cell lysates were equally loaded, the membranes were stripped of the primary antibodies using standard protocols and re probed with rabbit polyclonal antibodies specific for the unphosphorylated forms of either p38, p42 or JNK MAPKs (Santa Cruz). In some experiments for analysis of p42/44 ERKs, cell lysates were immunoprecipitated with rabbit anti-p42 antibodies. Total protein lysates (2 mg) were precleared with protein A-Sepharose 4B beads (Amersham Pharmacia Biotech) for 1 h at 4 °C followed by incubation for 2 h at 4 °C with protein A-Sepharose beads and anti-p42/44 rabbit polyclonal antibodies. The phosphorylated p42 ERK was detected by using 4G10 anti-phosphotyrosine antibodies. The immunoblots images were captured on a computer scanner and densitometry analysis performed to quantitate for the intensity of the bands.

RNA isolation and semi-quantitative RT-PCR analysis for B7-1 and B7-2

Total RNA from 2×10^6 LPS or IL-10-stimulated cells was extracted by using a monophasic solution containing guanidine thiocyanate and phenol (Tri Reagent solution, Molecular Research Center, Inc. Cincinnati, OH). The quantity of total RNA extracted was determined by measuring the absorbance at 260 nm using a standard spectrophotometer. Total RNA (1 μ g) was reverse transcribed at 42°C for 1 hour by using 500 units of M-MLV reverse transcriptase (Perkin-Elmer, Foster City, CA), 2.5 μ M random hexamers, 5 mM MgCl₂, 10 mM Tris-HCl (pH 8.3), 50 mM KCl, 20 units of RNase inhibitor, and 1 mM each of dGTP, dATP, dTTP, and dCTP.

Equal aliquots (5 μ l) of cDNA equivalent to 100 ng of RNA were subsequently amplified by polymerase chain reaction (PCR) for the expression of B7-1 or B7-2 and β -actin. The oligonucleotide primer sequences used for B7-1, B7-2 and β -actin (Stratagene, La Jolla, CA) were as follows: B7-1 sense 5'-AGT ACA AGA ACC GGA CCA TC-3'; B7-1 anti-sense 5'-GGC GTA CAC TTT CCC TTC TC-3'; B7-2 sense 5'-AGG ACA AGG GCT TGT ATC AA-3'; B7-2 anti-sense 5'-ATT GCT CGT AAC ATC AGG GA-3'; β -actin sense 5'-TGA CGG GGT CAC CCA CAC TGT GCC CAT CTA-3'; β -actin anti-sense 5'-CTA GAA GCA TTT GCG GTG GAC GAT GGA GGG-3'. The amplification conditions for B7-1, B7-2 and β -actin were as follows: denaturation at 95°C for 1 min, annealing at 62°C for 1 min and extension at 72°C for 1 min. After 30 cycles, the amplified B7-1 (605 bp), B7-2 (332 bp) and β actin (661 bp) fragments were resolved by electrophoresis on 1% agarose gels and visualized by ethidium bromide staining.

Transient Transfection of dominant-negative mutant of MKK-4/SEK1

THP-1 cells were transfected with a pcDNA-3 plasmid expressing a dominant-negative (DN) mutant of MKK-4/SEK1 (provided by Dr. J. R Woodget, Toronto, Ontario, Canada) or a control pcDNA-3 plasmid (174). Prior to transfection, 10 µg of the plasmids were incubated with 10 µl of LIPOFECTAMINE reagent (Life Technologies Inc., Burlington, ON) in 200 µl of OPTI-MEM I Reduced Serum Medium (Life Technologies) for 45 min to allow formation of DNA-liposome complexes. These complexes were added to the cell suspension (1.5×10^6 cells/ml) in each well and cultured for 24 hr. Following incubation, cells were stimulated with 1 µg/ml of LPS for another 24 hr followed by analysis of B7-2 expression.

Transfection of cells with JNK1 and JNK2 stealth RNA

THP-1/CD14 cells were resuspended at a concentration of 1×10^5 cells/well in a 96 well plate (Falcon) in a total volume of 100 µl. The cells were transfected with 50 pmol stealth RNA (Invitrogen) for either JNK1 or JNK2 using Fugene (Roche). Briefly Fugene and the stealth RNA were incubated in serum free IMDM media for 15 min at room temperature and then were added drop-wise to the cell culture. The final culture volume was 200 µl. The cells were incubated for 24 hr and then were treated with LPS (100 ng/ml) for an additional 16 hr. Cells were then harvested and analyzed for B7-1 expression by flow cytometry. The transfection efficiency was determined to be 10% through the use of BLOCK-IT fluorescent oligo that was included in the stealth RNA assay kit.

Construction of B7-1 and B7-2 Promoter/Luciferase reporter gene plasmids

The human B7-1 (accession number U33208) and B7-2 (accession AF099105) promoter sequences were obtained from NCBI GenBank™. Based on published sequences of B7-1 and B7-2 promoters, specific forward and reverse primers containing Kpn I, Nhe I or Bgl II restriction enzyme sites were designed with the aid of a Primer Designer version 2.0 software (Scientific and Educational Software) (Table 2-1 and Table 2-2). Genomic DNA was isolated from peripheral blood mononuclear cells from a normal healthy adult individual using a Tri Reagent solution (Molecular Research Center, Inc. Cincinnati, OH). Isolated genomic DNA was quantified using a standard spectrophotometer at an absorbance wavelength reading of 260 nm.

The PCR amplification of the promoter regions consisted of denaturation at 95°C for 1 min, annealing at 62°C for 1 min, and extension at 72°C for 1 min. After performing 1% agarose gel electrophoresis on the PCR amplified products, the PCR fragments were excised from the gel and purified (Qiagen gel extraction kit). The purified PCR products were ligated into the pCRII TOPO cloning vector using the TOPO TA Cloning Kit (Invitrogen). The B7-1 and B7-2 promoter fragments were then subcloned into the pGL3B or pGL3E luciferase reporter plasmids (Promega) via the Kpn I, Nhe I, or Bgl II polylinker sites. All of the promoter sequences were verified to be correct by DNA sequencing, as performed by the Biotechnology Research Institute (University of Ottawa). To introduce mutations in the B7-1 and B7-2 promoters, PCR-based site-directed mutagenesis were performed using primers designed to contain mutations (Table 2-1 and Table 2-2). Double NF- κ B mutants were generated by

megaprimer PCR-based site-directed mutagenesis using primers B7-2(-622) NF- κ B Mut, B7-2(-248)NF- κ B Mut, B7-2(-221), and B7-2(+63) (Table 2-2).

TABLE 2-1: Primer sequences used to amplify the B7-1 promoter fragments from genomic DNA.

Primer Name	Primer Sequence	Region Amplified (bp)	Product Length (bp)
Sense Primers			
B7-1(-587)	5'-GGGGTACCAATCCTACAAAGGGACACACA-3'	-587/+57	644
B7-1(-403)	5'-GGGGTACCGTAGAGTTGGGTGGTCTTGTG-3'	-403/+57	460
B7-1(-225)	5'-GAGCTAGCCAGATGCCCCTCACTCTTCTC-3'	-225/+57	282
B7-1(-84)	5'-GAGCTAGCAGCAAGTAGAAGAAGACGGCA-3'	-84/+57	141
B7-1(-84)Mutant1	5'-GAGCTAGCAGGTAGATGAAGAAGACGGCA-3'	-84/+57	141
B7-1(-84)Mutant2	5'-GAGCTAGCTGGATGAACATGAAGACGGCA-3'	-84/+57	141
B7-1(-72)	5'-GAGCTAGCAAGACGGCAGCAGAGGGCGC-3'	-72/+57	129
B7-1(-28)	5'-ATGCTAGCCTGGCACTGACAAGTACTGAG-3'	-28/+57	85
Antisense Primer			
B7-1(+57)	5'-GCAGATCTTAATCTTCAGAGAGGCGACAT-3'		

TABLE 2-2: Primer sequences used to amplify the B7-2 promoter fragments from genomic DNA

Primer Name	Primer Sequence	Region Amplified (bp)	Product Length (bp)
Sense Primers			
B7-2(-1247)	5'-GGGTACCGTCATCTGCTATTTTTAAACTTCC-3'	-1247/+63	1310
B7-2(-622)	5'-GGGTACCGTCTCTTAGGGACATCTATTAATTT-3'	-622/+63	685
B7-2(-622)NF-κB mutant	5'-GGGTACCGTCTCTTAAAACATCTATTAATTTTATAATGCTGCC-3'	-622/+63	685
B7-2(-591)	5'-GGGTACCGCTGCCTTTTTTTCAGACTTC-3'	-591/+63	654
B7-2(-257) NF-κB mutant	5'-TTTTCTAGGTTTTTTTGAAAAAATTTCAAGAGGGGAGATTTT-3'	-257/+63	320
B7-2(-248)	5'-GGGTACCTTTTTTGAGGGAATTTCAAGA-3'	-248/+63	311
B7-2(-248)NF-κB	5'-GGGTACCTTTTTTGAAAAAATTTCAAGAGGGGAGATTTT-3'	-248/+63	311
B7-2(-157)	5'-GGGTACCTAATACATATAGACCTACGTCAATGA-3'	-157/+63	220
B7-2(-148)	5'-GGGTACCTAGACCTACGTCAATGAGTTTAAA-3'	-148/+63	211
B7-2(-148) CREB mutant 1	5'-GGGTACCTAGACCTTTGTCAATGAGTTTAAACTGCAAG-3'	-148/+63	211
B7-2(-148) CREB mutant 2	5'-GGGTACCTAGACCAATGACTATGAGTTTAAACTGCAAGGAAA-3'	-148/+63	211
B7-2(-133)	5'-GGGGTACCGAGTTTAAACTGCAAGAAAG-3'	-133/+63	196
B7-2(-114)	5'-GGGGTACCAGGGTTAAATTTCTTCCTCAA-3'	-114/+63	177
B7-2(-105)	5'-GGGTACCTTCTTCCTCAAGTGTGGTCA-3'	-105/+63	168
B7-2(-95)	5'-GGGGTACCAAGTGTGGTCAAAATCTGTAGAG-3'	-95/+63	158
B7-2(-85)	5'-GGGTACCAAAATCTGTAGAGAAAAGAGGAAC-3'	-85/+63	148
B7-2(-75)	5'-GGGTACCCTGTAGAGAAAAGAGGAACA-3'	-75/+63	138
B7-2(-75)IRF-2 mutant 1	5'-GGGTACCCTGTAGAGAAAAGATCCCCA-3'	-75/+63	138
B7-2(-75)IRF-2 mutant 2	5'-GGGTACCCTGTAGATCCCCTAGGAACA-3'	-75/+63	138
B7-2(-65)	5'-GGGTACCGAACAGCTTCTCTTAAAGAAAGTT-3'	-65/+63	128
B7-2(-56)	5'-GGGTACCCTCTTAAAGAAAGTTAGCTG-3'	-56/+63	119
B7-2(-47)	5'-GGGTACCAAAGTTAGCTGGGTAGGTAT-3'	-47/+63	110
Antisense Primer			
B7-2(+63)	5'-GAAGATCTCCACTCATCCGTGTGTCTG-3'		
B7-2(-221)	5'-TCTCCCCTCTTGAAATTTTTTCAAAAAACCTAGAAAATAAATAATTA-3'	-622/-221	402

Transient DNA Transfection and Measurement of Luciferase Activity

For transient transfections, plasmids were isolated and purified using the Qiagen Endofree Plasmid Maxi Kit (Qiagen). THP-1 or THP-1/CD14 cells were transiently transfected by using DEAE-dextran. 15×10^6 cells/ml THP-1 or 5×10^6 cells/ml THP-1/CD14 cells were seeded into 6 well plates at 37°C for one hr. 2.5 µg of reporter plasmid and 2.5 µg of pSV-β-galactosidase control vector were mixed with 800 µg/ml of DEAE-Dextran in 1 ml of PBS buffer and added to the cells. The cells were incubated at 37°C for 30 min, washed twice with PBS, resuspended, and cultured for 24 hr in complete IMDM medium. Following incubation, the transfected cells were stimulated with or without LPS (1 µg/ml) for another 24 h. Cells were harvested and lysates were assayed for firefly luciferase activity and β-galactosidase activity by using the Luciferase assay and β-galactosidase assay kits, respectively (Promega) in a Bio Orbit 1250 luminometer (Fisher). Firefly luciferase activity for each transfection was normalized against the β-galactosidase activity.

Electrophoretic mobility shift assays

Electrophoretic mobility shift assay (EMSA) is a technique used to identify sequence-specific DNA-binding protein such as transcription factors. Cells (10^7) were harvested in Tris-EDTA-saline buffer pH 7.8 and centrifuged at 200 x g for 5 min. The cells were lysed for 10 min at 4°C with buffer A (10 mM HEPES, 10 mM KCl, 1.5 mM MgCl₂, 0.5 mM DTT, 0.5 mM PMSF, pH 7.9) containing 0.1% Nonidet P-40. The lysates were centrifuged at 20,000 x g for 10 min. The pellet containing the nuclei was suspended in buffer B (20 mM HEPES, 420 mM NaCl, 1.5 mM MgCl₂, 0.2 mM EDTA

0.5 mM DTT, 0.5 mM PMSF, and 25% glycerol) at 4°C for 15 min. Buffer B also contained spermidine (0.5 mM), spermine (0.15 mM), and 5 µg/ml each of the proteolytic inhibitors aprotinin, leupeptin, and pepstatin. The supernatant containing the nuclear proteins was collected and frozen at -80° C.

³²P-labeled oligonucleotide probes were generated by 5'-end labeling using T4 polynucleotide kinase and [γ -³²P]-ATP as per standard methods. Nuclear proteins (5 µg) were mixed for 20 min at room temperature with ³²P-labeled oligonucleotide probes, and the complexes were subjected to non-denaturing 5 % PAGE for 90 min. After PAGE, the gel was transferred and sandwiched between a Whatman paper and cellophane and dried using a gel dryer for 60 minutes at 80°C, prior to exposure to an autoradiography film (Kodak) in an X-ray cassette. The oligonucleotide sequences used are as follows: B7-1 (-90/-67) binding sites of the B7-1 promoter 5'-(TAC AAA AGC AAG TAG AAG AAG ACG)-3' and 3'-(ATG TTT TCG TTC ATC TTC TTC TGC)-5'. PRD-I oligonucleotides containing IRF-7/IRF-3 consensus sequences were as follows: 5'-(GAG AAG TGA AAG TG)-3' and 3'-(CTC TTC ACT TTC AC)-5'. Consensus NFκB 5'-(AGT TGA GGG GAC TTT CCC AGG C)-3' and 3'-(TCA ACT CCC CTG AAA GGG TCC G)-5' and AP-1 oligonucleotides 5'-(CGC TTG ATG AGT CAG CCG GAA)-3' and 3'-(GCG AAC TAC TCA GTC GGC CTT)-5' were obtained from Promega (Madison, WI). To illustrate specificity of nuclear factor binding to labelled probes, parallel EMSA reactions were incubated with 50 to 200 fold excess of cold unlabelled oligonucleotides, and non-specific NFκB probes (Promega).

Statistical analysis

Means were compared by the two tailed Student's t test. The results are expressed as mean \pm SD.

CHAPTER 3:
STUDIES ON THE REGULATION OF B7-1 IN HUMAN MONOCYTIC CELLS

Introduction

T cell activation requires two critical signals provided by an antigen presenting cell. The first signal involves recognition by the T-cell receptor of the MHC/antigen complex presented on the surface of the APC. B7 molecules, when expressed by the APC, can provide a crucial second non-specific co-stimulatory signal by serving as a ligand for CD28 expressed on the surface membranes of T cells (15,176,177). The second signal is necessary for IL-2 production by T cells to ensure an active cellular immune response (15,177,178). The engagement of CD28 with B7 leads to multiple effects on immune responses including T cell activation and differentiation (179,180), tissue migration (181), and peripheral tolerance induction (182,183). The pleiotropic activities of the CD28/B7 pathway can thus be exploited for the potential clinical usefulness in immune intervention in such diseases as autoimmunity, transplant rejection, as well as in the elimination of tumors that evade immune surveillance (50,52,184,185).

In light of the influence of B7 expression on immune functions, alterations in B7-1 expression may have profound effects on immune responsiveness and disease progression. Therefore, understanding the mechanisms and characterization of signal transduction events regulating B7-1 expression may facilitate the design of strategies for treatment of autoimmune diseases and cancer. Very little is known about the signal transduction pathways involved in B7-1 regulation (160,161). In one study, a cell type-specific 183 bp enhancer element 3 kb upstream of the transcription start site of the human B7-1 gene was found to be responsive to stimulation with two distinct stimuli, LPS and dibutyryl cAMP, both known to regulate B7-1 expression (160). Site-directed mutagenesis of this region revealed the presence of an NFkB consensus sequence that

was consequently implicated in B7-1 transcription. Interestingly, the promoter region immediately upstream of the transcription start site was found to be inactive unless linked with its native enhancer element (160). Subsequently, Fong et al identified a positive regulatory B7 regulatory element (B7-RE), located at -60 to -47 bp upstream of the transcription start site that regulated B7-1 transcription. However, the identity of the transcription factor binding to the B7-1 RE was not established (161).

In this study, I have investigated the regulation of B7-1 expression in primary human monocytes and the promonocytic THP-1/CD14 cells in response to stimulation with LPS, a bacterial cell wall component and an important contributor to sepsis. I investigated the role of mitogen-activated protein kinases as they play a key role in cellular responses such as proliferation, differentiation and apoptosis (114). The three main families of MAPKs are the extracellular signal-regulated protein kinases (ERKs), the c-Jun N-terminal kinases (JNKs) and the p38 MAPKs (114,116). LPS is known to activate all three types of MAPKs (186,187). My results show that B7-1 expression in response to LPS stimulation is regulated by JNK MAPKs in both primary monocytes and THP-1/CD14 cells. In addition, I identified a distinct B7-1 responsive element corresponding to the IRF-7 binding site, located at -84 to -73 bp upstream of transcription start site of the B7-1 gene. The results suggest that LPS-induced B7-1 expression may be regulated by IRF-7 transcription factor through the activation of JNK MAPKs.

Results

LPS-induced B7-1 expression involves the activation of JNK MAPKs in human monocytes and THP-1/CD14 cells

Initially, it was necessary to confirm the previous observations made that LPS induces B7-1 expression on primary monocytes as determined by flow cytometry and RT-PCR analysis (Fig. 3-1) (37). To understand the signaling pathway involved in B7-1 regulation, I first investigated the role of p38 and ERK MAPKs in LPS-stimulated monocytes. Monocytes isolated from healthy individuals were stimulated with LPS for 10 min as it was determined to be the optimal time from kinetic experiments. Immunoblotting for p38 and ERKs activation was then performed by using anti-phospho-p38 and anti-phospho-p42/44 ERK specific antibodies, respectively. The same blots were stripped and reprobed with anti-p38 and anti-p42/44 antibodies to ensure equal protein loading. The results show that LPS stimulation induced the phosphorylation of p38 and p42/44 ERKs (Fig 3-2A). It was demonstrated that specific inhibitors for p38, SB202190 and for ERKs, PD98059, at concentrations of 12 μ M inhibited the phosphorylation of p38 and ERK MAPKs, respectively (Fig. 3-2A). To determine the role of p38 and ERK MAPKs in LPS-induced B7-1 expression, I analyzed B7-1 expression by flow cytometry in LPS-stimulated monocytes after 2 hr incubation with the specific inhibitors. B7-1 induction was not inhibited by either SB202190 or PD98059 at any concentration (Fig 3-2B).

I next examined the role of the JNKs, the third major member of the MAPK family, by employing its specific inhibitor, SP600125 (173), and other agents such as DXM and curcumin, which have been shown to block the activation of JNK MAPKs

FIGURE 3-1: LPS up-regulates B7-1 expression in monocytes.

(A) Purified human monocytes ($0.5 \times 10^6/\text{ml}$) were stimulated with LPS ($1 \mu\text{g}/\text{ml}$) for 24 h followed by analysis for B7-1 expression by flow cytometry.

(B) Monocytic cells were stimulated with LPS ($1 \mu\text{g}/\text{ml}$) for 0 to 12 h and the cells were harvested for mRNA isolation. B7-1 expression was determined by semiquantitative reverse transcriptase-based PCR (RT-PCR) analysis using β -actin as a standard control. The experiment shown is representative of three experiments.

A

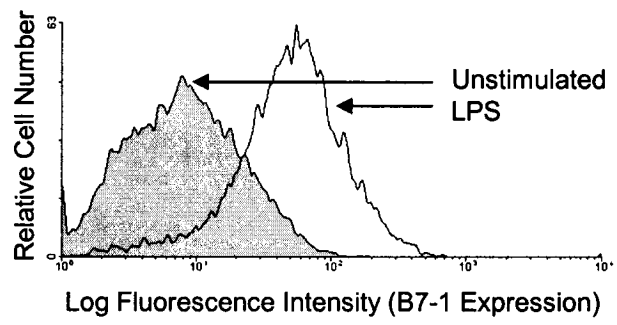

B

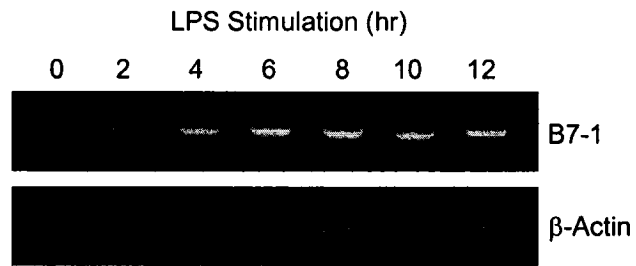
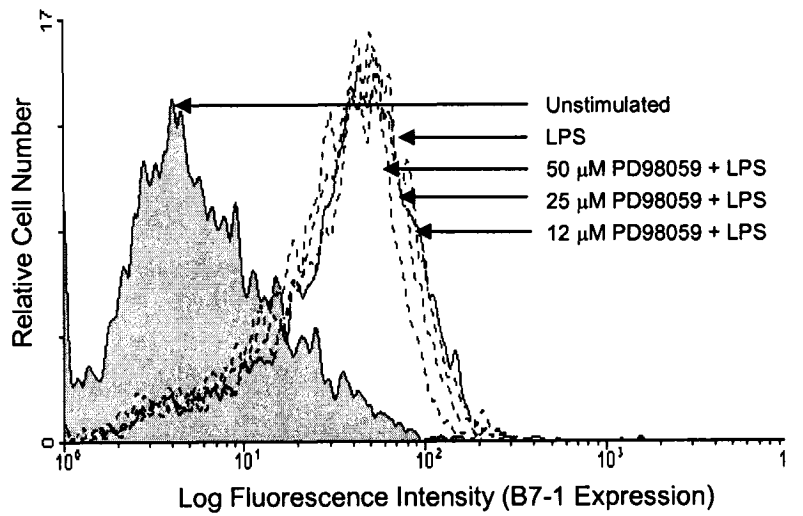
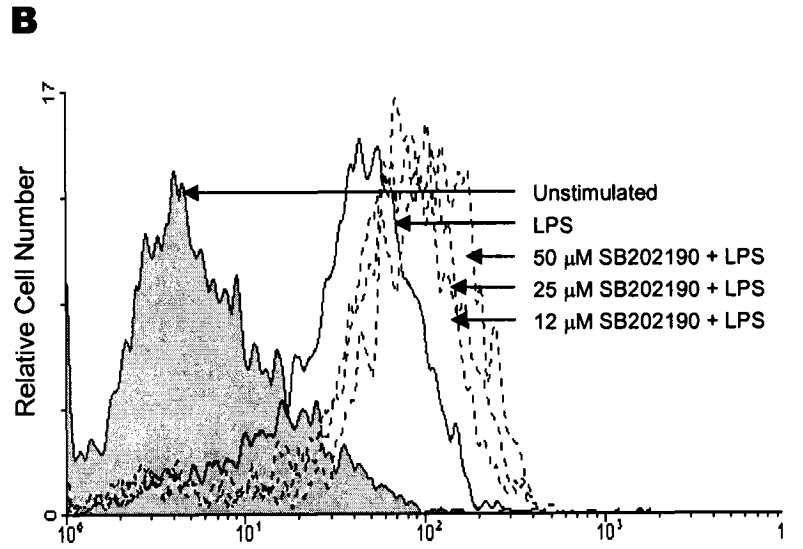
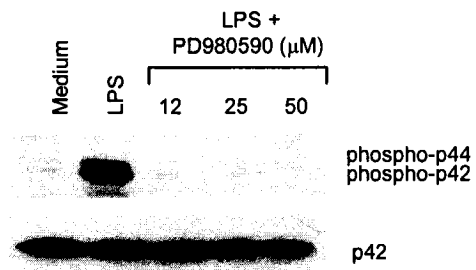
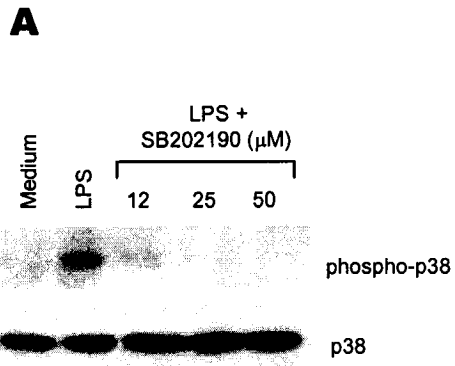

FIGURE 3-2: LPS-induced B7-1 expression in human monocytes is not regulated by p38 or ERK MAPKs.

(A) Purified monocytes (0.5×10^6 /ml) were treated with either SB202190 or PD98059 at concentrations ranging from 0 to 50 μ M for 2 h before LPS (1 μ g/ml) stimulation for 10 min. Total proteins (50 μ g) were analyzed by Western blot analysis using either anti-phospho-p38 (pp38) or anti-phospho-p42/44 (pp42/44) antibodies. To control for equal protein loading, the membranes were stripped and reprobbed with either anti-p38 or anti-p42/44 Abs, respectively.

(B) Monocytes were treated with either SB202190 or PD98059 at concentrations ranging from 0 to 50 μ M for 2 h before stimulation with LPS (1 μ g/ml) for 24 h followed by analysis of B7-1 expression by flow cytometry. The experiment shown is representative of three experiments.



(173,188). LPS induced the phosphorylation of JNK MAPKs, and its specific inhibitors, SP600125, DXM, and curcumin, inhibited JNK phosphorylation in monocytes (Fig. 3-3A). SP600125 did not affect the phosphorylation of p38 and ERK MAPKs confirming the specificity of SP600125 (data not shown). Furthermore, LPS-induced B7-1 expression in monocytes was inhibited by DXM, SP600125, and curcumin in a dose dependent manner (Fig 3-3B).

To further understand the role of JNK, I employed the promonocytic THP-1/CD14 cells which constitutively expressed the LPS-receptor, CD14, on their surface membrane (Fig. 3-4) (174). Stimulation of THP-1/CD14 cells with LPS induced B7-1 expression as determined by flow cytometry and RT-PCR analysis (Fig 3-5) and in a manner similar to that observed on LPS-stimulated monocytes (Fig. 3-1). The THP-1/CD14 cells express high levels of CD14 and are more responsive to LPS effect on B7-1 expression than the THP-1 cells. To assess the role of JNK in B7-1 expression in the THP-1/CD14 cells, I first demonstrated that LPS induced the phosphorylation of JNK, and this activation was inhibited by SP600125, DXM, and curcumin (Fig. 3-6A). LPS-induced B7-1 expression in THP-1/CD14 cells was completely inhibited by SP600125, DXM, and curcumin as determined by flow cytometry, and in a manner similar to that observed in LPS-stimulated monocytes (Fig. 3-6B and Fig. 3-3B). Experiments were repeated at least three times and in all three experiments the results were the same. To further confirm the involvement of JNK in the regulation of B7-1 expression, I used stealth siRNAs (Invitrogen Life Technologies) specific for JNK1 and JNK2 to knock down endogenous JNK expression. Briefly, according to the manufacturer's specifications, THP-1/CD14 cells were transfected with siRNA for JNK1, JNK2, or

FIGURE 3-3: LPS-induced B7-1 expression in human monocytes is regulated by JNK MAPKs.

(A) Purified monocytes ($0.5 \times 10^6/\text{ml}$) were treated with various concentrations of SP600125, DXM, and curcumin for 2 h before stimulation with LPS ($1 \mu\text{g}/\text{ml}$) for 15 min. Total cell proteins were analyzed for phosphorylation of JNK MAPK using anti-phospho-JNK Ab. To control for protein loading, the membranes were stripped and reprobed with anti-JNK Abs.

(B) Monocytes ($0.5 \times 10^6/\text{ml}$) were treated with various concentrations of SP600125, DXM, and curcumin for 2 h before stimulation with LPS ($1 \mu\text{g}/\text{ml}$) for 24 hr followed by analysis of B7-1 expression by flow cytometry. The experiment shown is representative of three experiments.

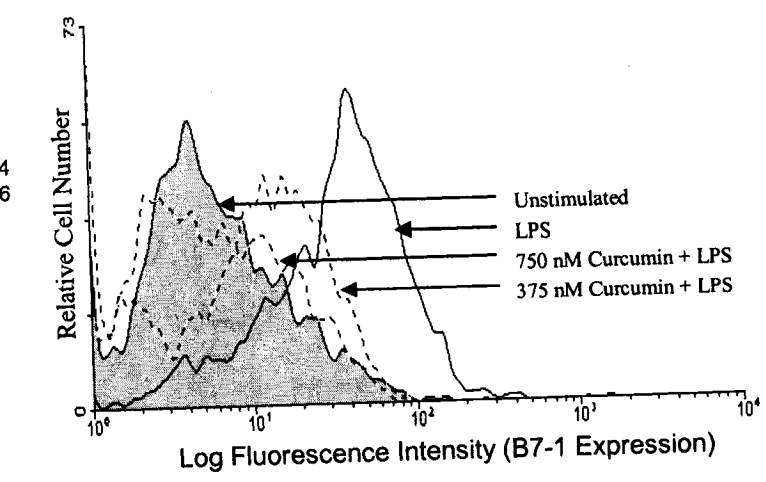
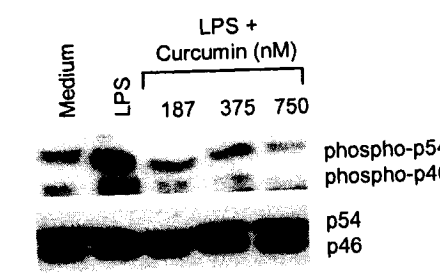
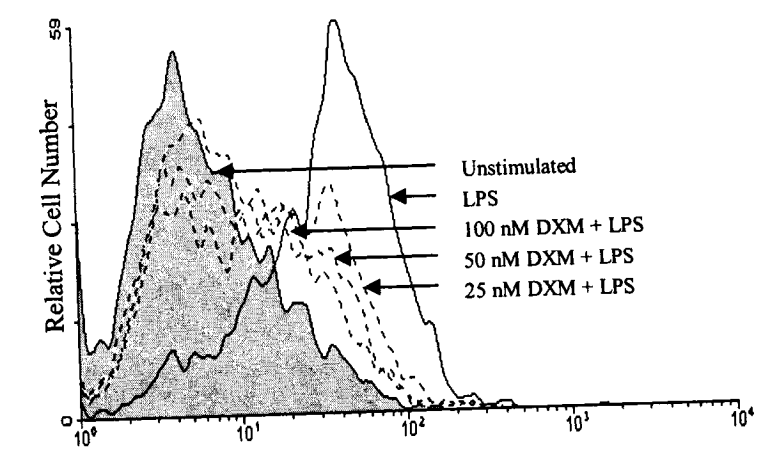
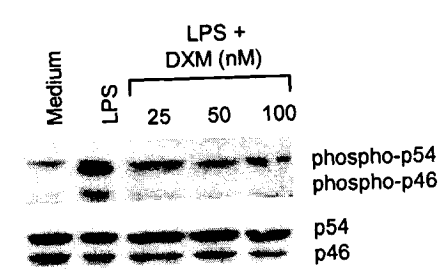
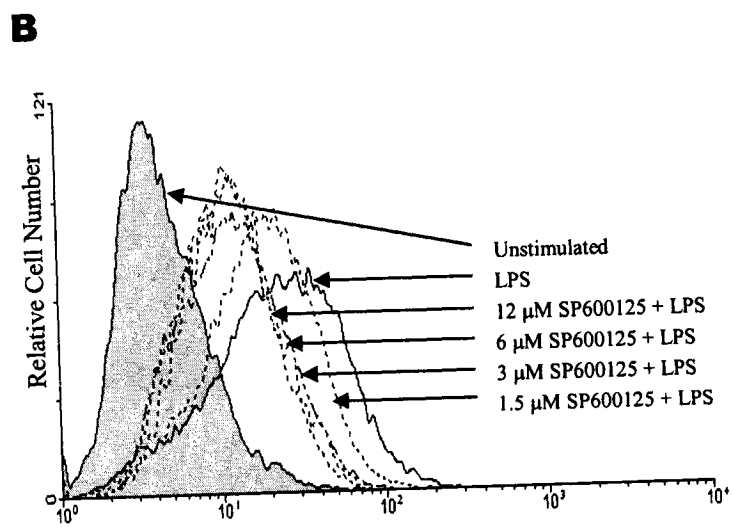
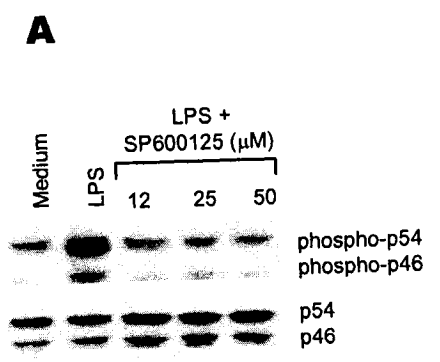

FIGURE 3-4: Flow cytometric analysis of CD14 expression on THP-1 and THP-1/CD14 cells.

THP-1 and THP-1/CD14 cells were stimulated with LPS (1 $\mu\text{g/ml}$) for 24 h and analyzed by flow cytometry for CD14 surface expression.

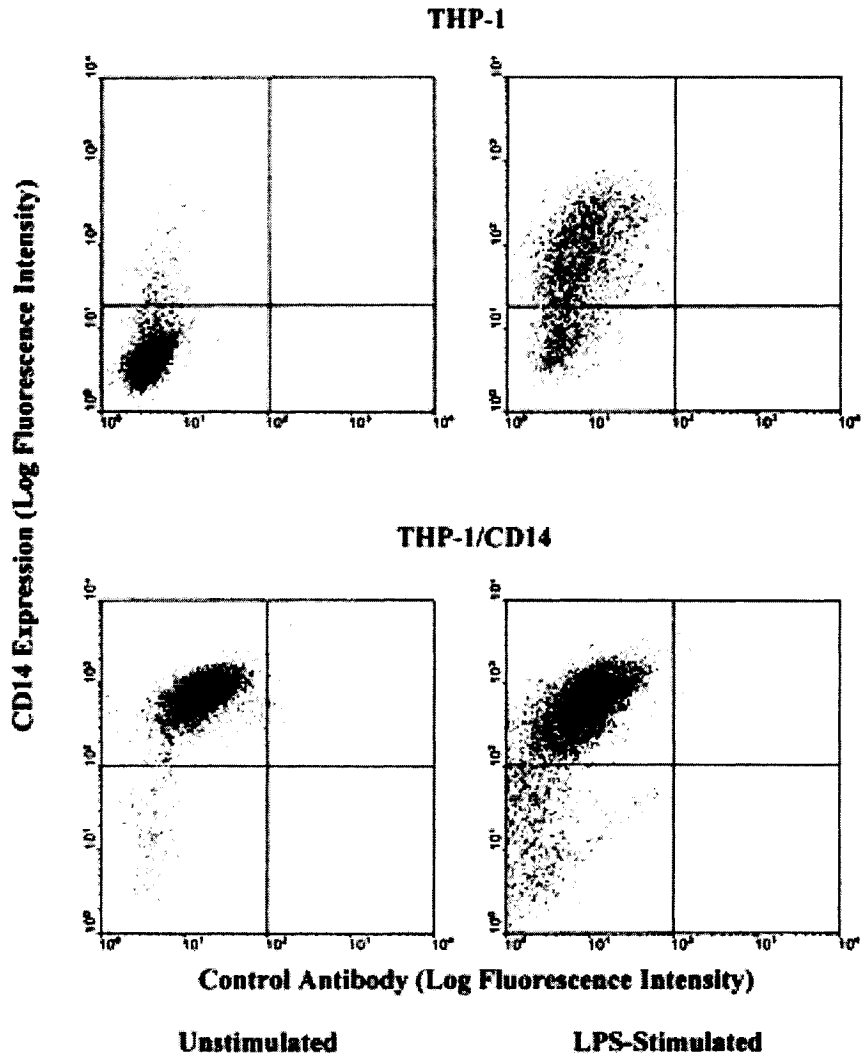
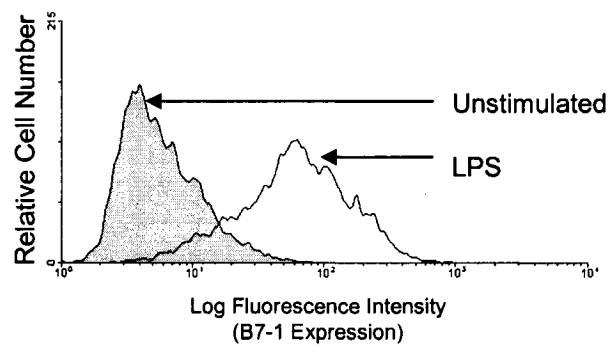

FIGURE 3-5: LPS up-regulate B7-1 expression in THP-1/CD14 cells.

(A) THP-1/CD14 cells (1×10^6 /ml) were stimulated with LPS ($1 \mu\text{g/ml}$) for 24 h followed by analysis for B7-1 expression by flow cytometry.

(B) THP-1/CD14 cells (1×10^6 /ml) were stimulated with LPS ($1 \mu\text{g/ml}$) for times ranging from 0 to 10 h following which the cells were harvested for mRNA isolation. B7-1 expression was determined by semiquantitative RT-PCR analysis using β -actin as a standard control. The experiment shown is representative of three experiments.

A



B

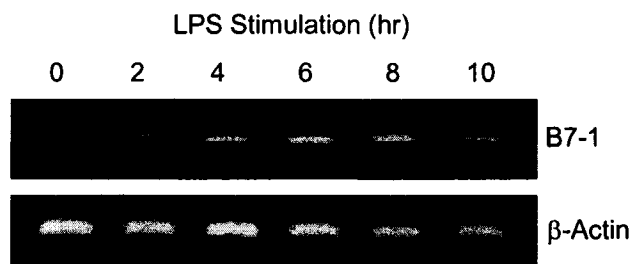
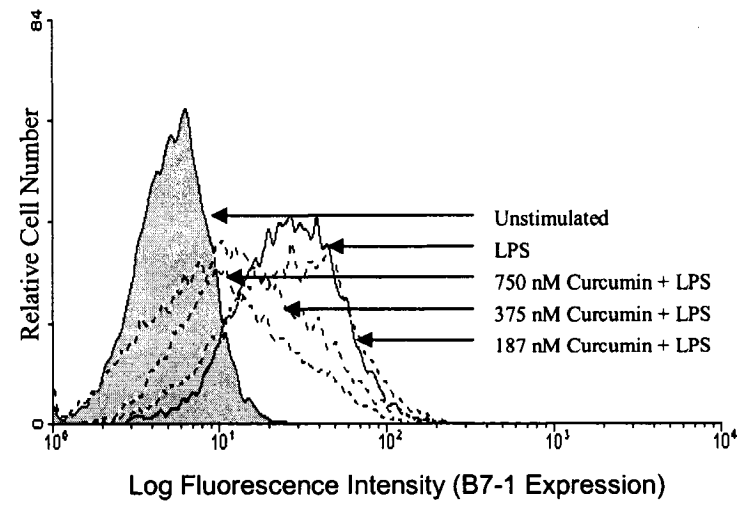
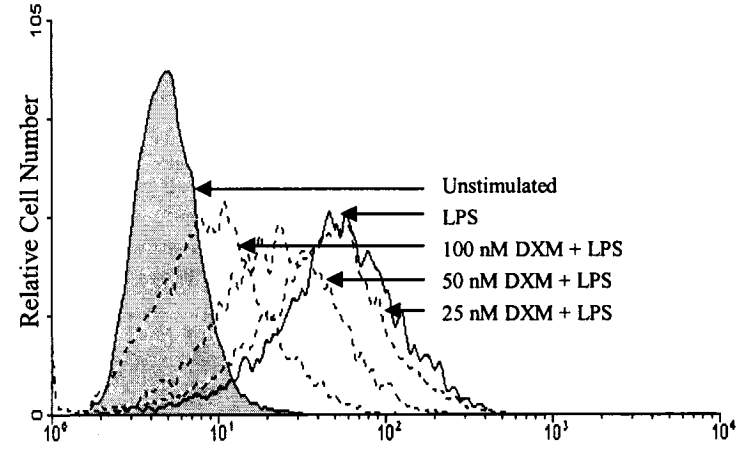
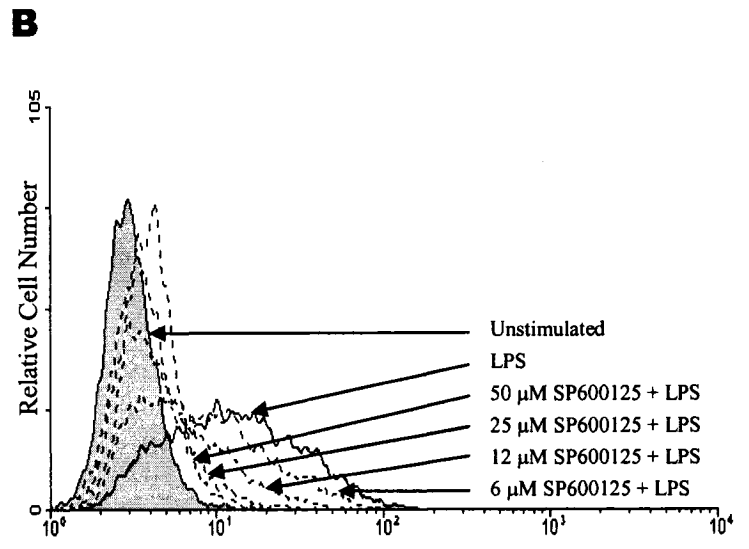
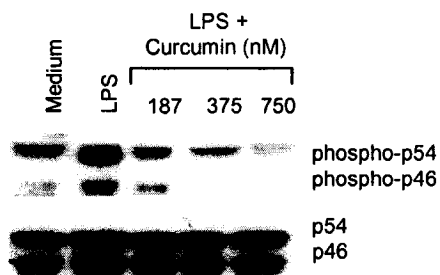
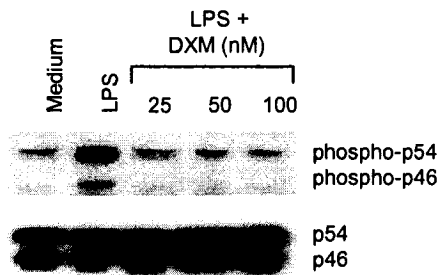
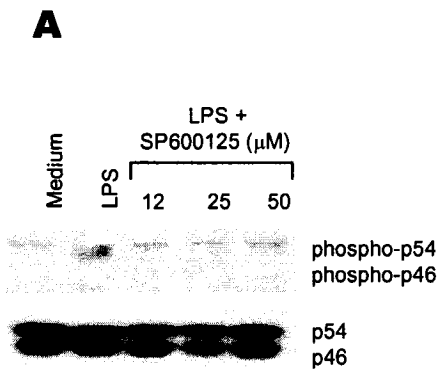

FIGURE 3-6: LPS-induced B7-1 expression in THP-1/CD14 cells is regulated by JNK MAPKs.

(A) THP-1/CD14 cells (1×10^6 /ml) were treated with various concentrations of either SP600125, DXM, or curcumin for 2 h before stimulation with LPS ($1 \mu\text{g/ml}$) for 15 min. Total proteins were analyzed for phosphorylation of JNK MAPK using anti-phospho-JNK Ab. To control for protein loading, the membranes were stripped and reprobed with anti-JNK Abs.

(B) THP-1/CD14 cells (1×10^6 /ml) were treated with either SP600125, DXM, or curcumin for 2 h before stimulation with LPS, followed by analysis of B7-1 expression by flow cytometry. The experiment shown is representative of three experiments.



Log Fluorescence Intensity (B7-1 Expression)

control siRNA for a period of 24 h, followed by LPS stimulation for 10 min. Transfection of cells with siJNK1 or siJNK2 RNAs significantly inhibited endogenous expression of JNK1 and JNK2, respectively (Fig. 3-6C, left panel). After LPS stimulation, transfection with siRNA specific for JNK2 inhibited JNK2 phosphorylation, whereas transfection with JNK1 siRNA inhibited the phosphorylation of both JNK1 and JNK2 compared with the cells transfected with control siRNA (Fig. 3-6C, lower panel). Because it is difficult to transfect a high proportion of THP-1 cells, and LPS, being a powerful mitogen, can induce B7-1 expression at very low concentrations (10 ng/ml), I stimulated cells transfected with various siRNA preparations with a lower LPS concentration (100 ng/ml) and for a short duration of 8 h, in contrast to 24 h used previously. Transfection of cells with siRNAs specific for JNK1 and JNK2 significantly inhibited LPS-induced B7-1 expression compared with cells transfected with control siRNA (Fig. 3-6C, right panel).

LPS-induced B7-1 mRNA expression in human monocytes and THP-1/CD14 cells was also completely inhibited by SP600125 and DXM, as determined by RT-PCR analysis (Fig. 3-7). The analysis for cell viability on cells pretreated with signaling inhibitors was performed by flow cytometry analysis on propidium iodide stained THP-1/CD14 cells (Table 3-1). Propidium iodide can penetrate the cell membrane of dying or dead cells and intercalate with the DNA during apoptosis or cell death. As determined by cell cycle analysis, pretreatment of signaling inhibitors SB202190, PD98059, SP600125, DXM, and curcumin at the doses employed had no toxic effect on THP-1/CD14 cells (Table 3-1).

FIGURE 3-6C: LPS-induced B7-1 expression in THP-1/CD14 cells is regulated by JNK MAPKs as determined by siRNA for JNK1 and JNK2.

(C) Stealth siRNA specific for JNK1 and JNK2 MAPK inhibits LPS-induced B7-1 expression. Stealth siRNAs for JNK1 and JNK2 block endogenous expression as well as LPS-induced JNK1 and JNK2 phosphorylation, respectively. THP-1/CD14 cells were transfected with stealth siRNA specific for JNK1, JNK2, or control RNA and cultured for 24 h, followed by LPS stimulation for 10 min. Endogenous expression of JNK1 and JNK2 in unstimulated cells (upper panel) and of phosphorylated JNK1 and JNK2 in LPS-stimulated cells (lower panel) was analyzed by Western blotting. Cells (1×10^5 /well) were transfected with stealth siRNA for JNK1 or JNK2, or control siRNA for 24 h, followed by LPS stimulation (100 ng/ml) for 8 h and analysis for B7-1 expression by flow cytometry. I would like to acknowledge and thank Dr. Katrina Gee for performing the stealth siRNA work. The experiments shown are representative of three experiments.

C

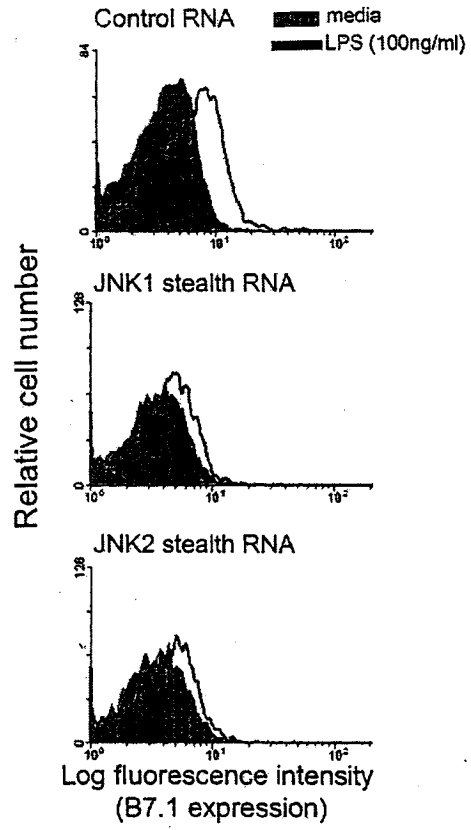
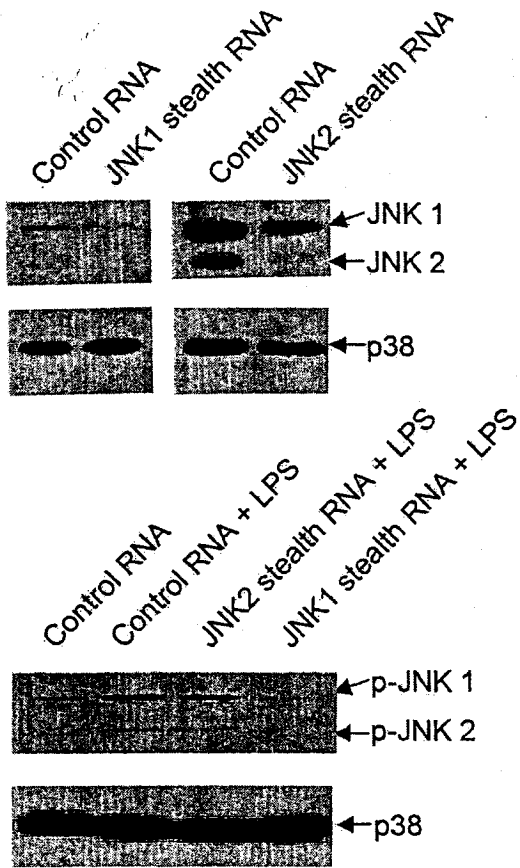
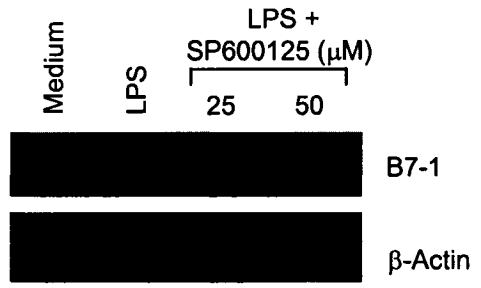
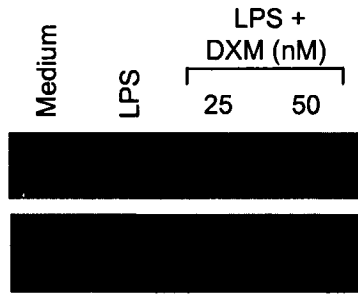

FIGURE 3-7: LPS-induced B7-1 mRNA expression in human monocytes and THP-1/CD14 are regulated by JNK MAPKs.

Monocytes ($0.5 \times 10^6/\text{ml}$) and THP-1/CD14 cells ($1 \times 10^6/\text{ml}$) were treated with various concentrations of DXM and SP600125 for 2 h before stimulation with LPS ($1 \mu\text{g}/\text{ml}$) for 6 hr followed by analysis of B7-1 expression by flow cytometry. The cells were harvested for mRNA isolation and B7-1 expression was determined by semiquantitative reverse transcriptase-based PCR (RT-PCR) analysis using β -actin as a standard control. The experiment shown is representative of three experiments.

Monocytes



THP-1/CD14

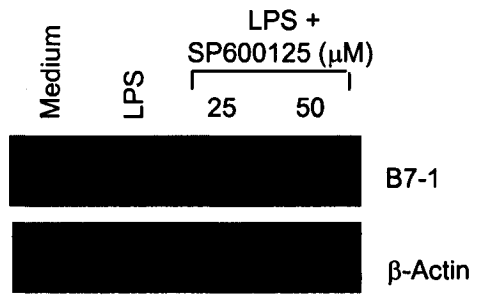
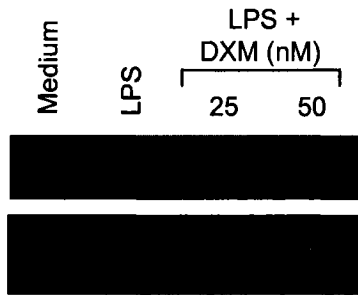

TABLE 3-1: Pretreatment of signaling inhibitors had no toxic effect on THP-1/CD14 cells.

Comparison of the magnitude of the subdiploid DNA fluorescent peak during FACS analysis and propidium iodide staining of the THP-1/CD14 cells. I would like to acknowledge and thank Sasmita Mishra for her propidium iodide staining experiments.

	% of cells in the subdiploid DNA fluorescent peak
Unstimulated	2.26%
LPS	1.50%
10 μ M SB202190 + LPS	1.03%
25 μ M SB202190 + LPS	1.27%
50 μ M SB202190 + LPS	1.48%
10 μ M PD98059 + LPS	1.47%
25 μ M PD98059 + LPS	1.97%
50 μ M PD98059 + LPS	1.85%
10 μ M SP-600125 + LPS	1.68%
25 μ M SP-600125 + LPS	1.72%
50 μ M SP-600125 + LPS	2.30%
25 nM Dexamethasone + LPS	1.21%
50 nM Dexamethasone + LPS	1.31%
100 nM Dexamethasone + LPS	1.27%
23 nM Curcumin + LPS	1.84%
46 nM Curcumin + LPS	1.75%
93 nM Curcumin + LPS	1.77%
187 nM Curcumin + LPS	1.69%
375 nM Curcumin + LPS	1.66%
750 nM Curcumin + LPS	1.35%

Role of the IRF-7 binding site within the B7-1 promoter in LPS-induced B7-1 transcription

To assay for promoter activity, a series of optimization experiments were first performed to determine the conditions required for maximal luciferase activity (Fig. 3-8). THP-1/CD14 cells were transfected with different amounts of pGL3 Control plasmid DNA by the DEAE-dextran method. The pGL3 Control plasmid contained a luciferase reporter gene, which is constitutively driven by a SV40 promoter/enhancer region. After incubation, the transfected cells were harvested and the cell lysates assayed for luciferase and β -galactosidase activity. β -galactosidase activity was determined and used to normalize all results for transfection efficiency. The optimization experiments determined that maximal luciferase activity was achieved when 5×10^6 THP-1/CD14 were transfected with 2.5 μ g of pGL3 Control plasmid and 800 μ g/ml of DEAE-dextran, and incubated for 30 min (Fig. 3-8). Therefore, I used these same conditions for transfection in all of the subsequent B7-1 promoter activity experiments

To understand the regulation of B7-1 transcription, I amplified the B7-1 promoter fragment encompassing nucleotide residues from 5' -587 to 3' +57 bp relative to the transcription start site (Fig. 3-9) and subcloned the fragment into Kpn I and Bgl II sites of the luciferase reporter plasmid, pGL3E. Cells were transiently transfected with the B7-1 promoter/luciferase reporter plasmid (pB7.1Pr-GL3E). Cells were stimulated with 1 μ g/ml LPS after 24 hr of transfection and cultured for 0-24 hr, following which relative luciferase activity was assessed. The unstimulated cells exhibited basal luciferase activity that was four fold higher than the activity observed in cells transfected with the

FIGURE 3-8: Optimization experiments for the DEAE-Dextran transfection of pGL3Control plasmid DNA into THP-1/CD14 cells.

Various concentrations of THP-1/CD14 cells were transiently cotransfected with different amounts of pGL3 Control vector and with 2.5 μ g of pSV- β -galactosidase control plasmid using the DEAE-dextran method. Cells were incubated with a range of DEAE-dextran and for various lengths of time. Luciferase activity was normalized for β -galactosidase activity to give relative luciferase units (RLU).

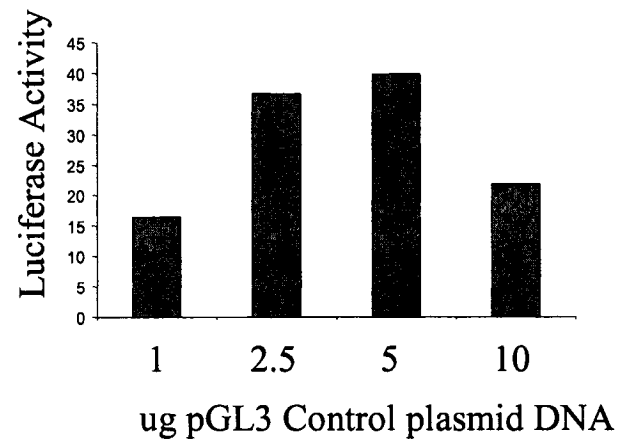
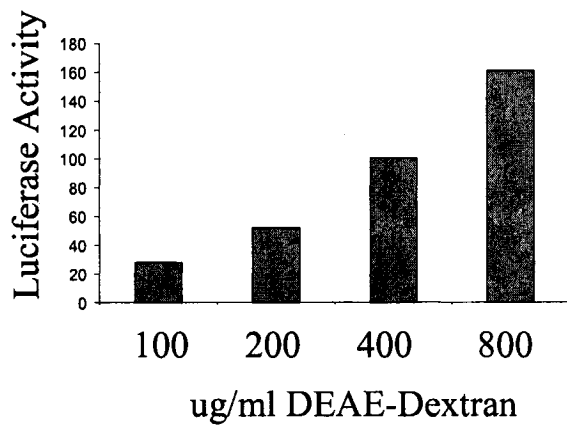
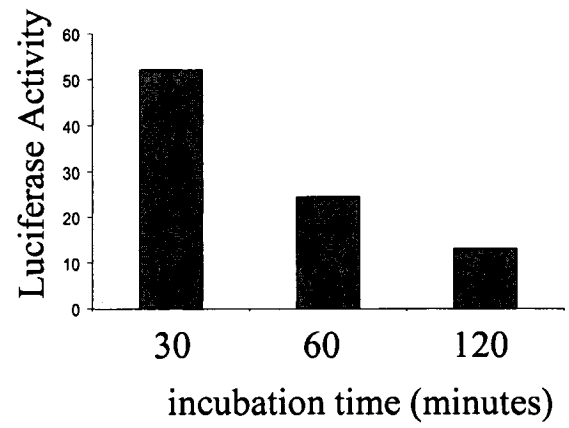
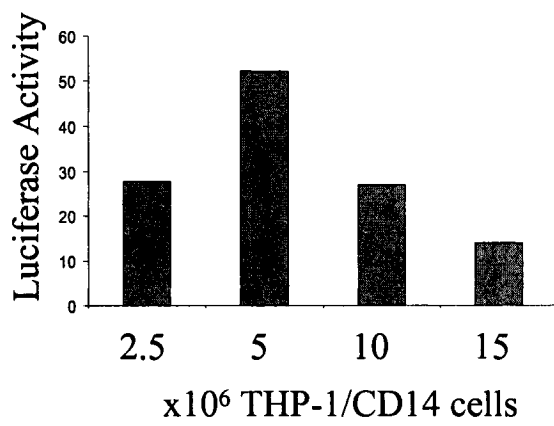
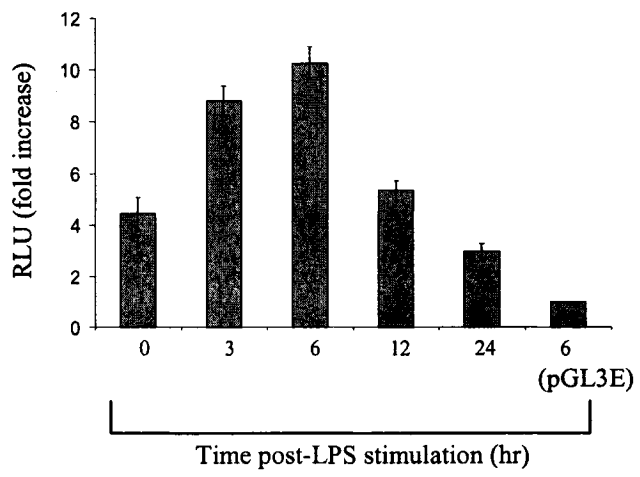

FIGURE 3-9: LPS-stimulation induces luciferase activity in THP-1/CD14 cells transfected with a B7-1 promoter/luciferase reporter gene construct.

THP-1/CD14 cells (5×10^6 cells/ml) were transiently cotransfected with 5 μ g of either B7-1 promoter/luciferase reporter gene construct or pGL3E vector control and with 2.5 μ g of pSV- β -galactosidase control plasmid. Cells were incubated for 24 h followed by treatment with 1 μ g/ml of LPS for various times. Luciferase activity was normalized for β -galactosidase activity to give relative luciferase units (RLU). The results shown are a mean \pm S.D. of three independent experiments performed in triplicate.



promoterless pGL3E control vector. The increase in luciferase activity was detected by 3 hr and peaked at 6 hr following LPS stimulation (Fig. 3-9). The maximum increase in luciferase activity ranged approximately two to three fold relative to the unstimulated cells and 10 to 12 fold relative to the cells transfected with the pGL3E control plasmid. The cells transfected with the pGL3E alone did not show any increase in luciferase activity following LPS stimulation (data not shown). In subsequent experiments, I measured luciferase activity in cells stimulated with LPS for 6 hr.

To identify the transcription factor binding sequences required for B7-1 transcription, I generated a series of deletion fragments from the B7-1 promoter (from 5' -587 to 3' +57 bp) by successive deletions starting from the 5'-end. The exact size of the amplified product and the location of consensus sequences for different transcription factors identified within the B7-1 promoter are depicted in Figs. 1-6 and 3-10A. Transfection of cells with plasmids containing various deletions of the B7-1 promoter revealed that deletion of sequences from -587 to -84 bp did not affect luciferase activity following LPS stimulation compared to the cells transfected with the entire promoter sequence. I consistently observed increased luciferase activity in cells transfected with the pB7.1Pr-GL3E fragment containing -84 to +57 bp; however, this increase was not significant when compared to cells transfected with the entire fragment (Fig 3-10A). In contrast, deletion of sequences upstream of -72 bp significantly decreased the luciferase activity (Fig. 3-10A) suggesting that DNA sequences located between -84 to -72 bp may be necessary for B7-1 gene transcription in LPS-stimulated THP-1/CD14 cells.

By employing MatInspector Professional, analysis of the B7-1 promoter sequence between -84 to -72 bp revealed the existence of a sequence similar to the IRF-7

FIGURE 3-10: Transcriptional activities of B7-1 promoter in LPS-stimulated THP-1/CD14 cells.

(A) The positions of the potential regulatory elements in the B7-1 promoter region (-587 to +57 bp relative to the start site). The line diagram represents the extent of deletions within the B7-1 promoter region. THP-1/CD14 cells were cotransfected with 5 μ g of either promoter deletion construct or vector control and with 2.5 μ g of β -galactosidase control plasmid. After 24 h of incubation, cells were stimulated with LPS (1 μ g/ml) for another 24 h. Cell lysates from LPS-stimulated cells were assayed for luciferase and β -galactosidase activities. Luciferase activity was normalized for β -galactosidase activity to give relative luciferase units (RLU). The results shown are a mean \pm S.D. of six experiments performed in triplicate.

(B) The effect of mutating the B7-1 -84 to -72 region on B7-1 promoter activity in LPS-stimulated THP-1/CD14 cells. A site-directed mutation of the B7-1 -84 to -72 sequence within the B7-1 promoter is shown in Fig. 3-10A with respect to the wild type sequence. The substituted nucleotides at positions are underlined. The amplified fragment (-84 to +57 bp) containing the mutations was cloned into a pGL3E vector. THP-1/CD14 cells were cotransfected with either 5 μ g of wild type or mutant B7-1 constructs and with 2.5 μ g of β -galactosidase control vector followed by LPS stimulation and measurement of luciferase activities (RLU) as described above. Results shown are a mean \pm S.D. of three independent experiments performed in triplicate.

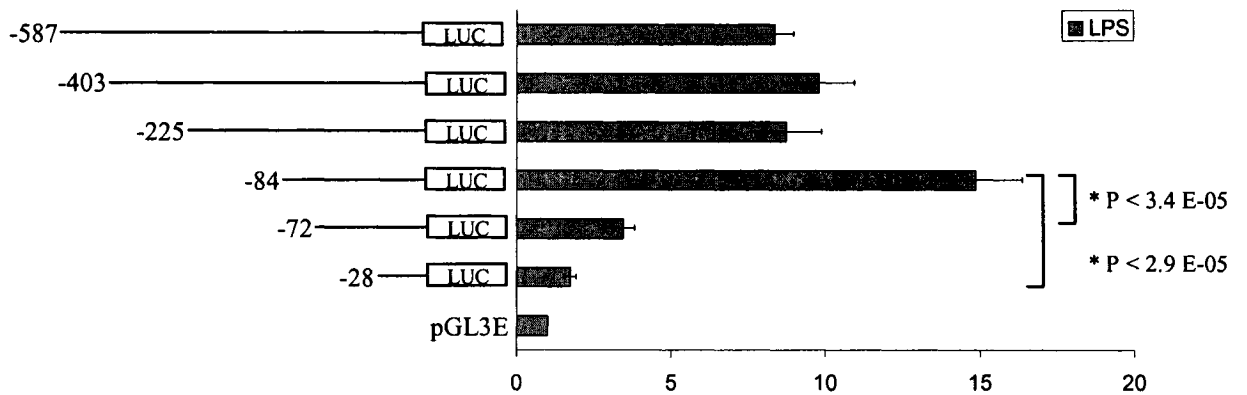
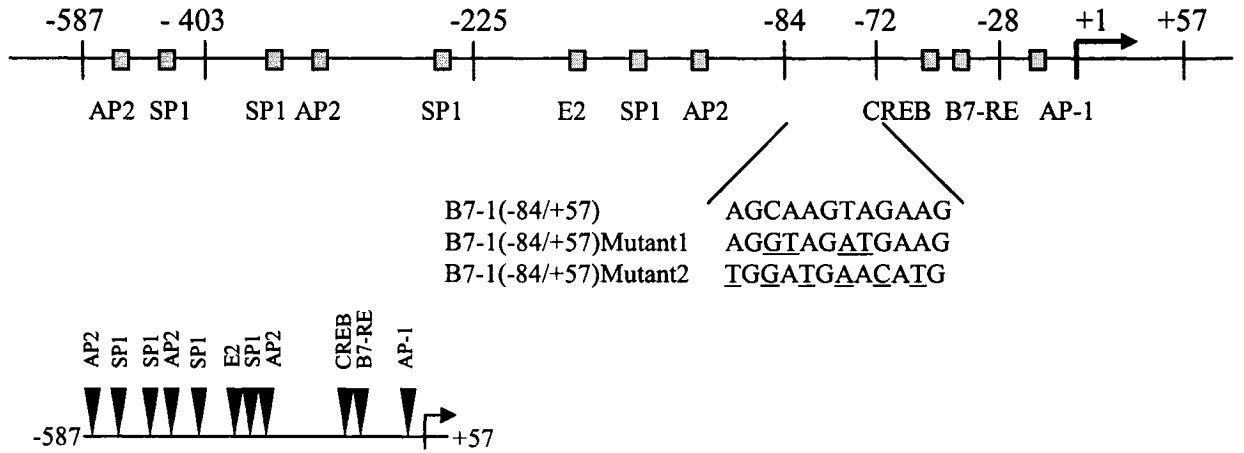
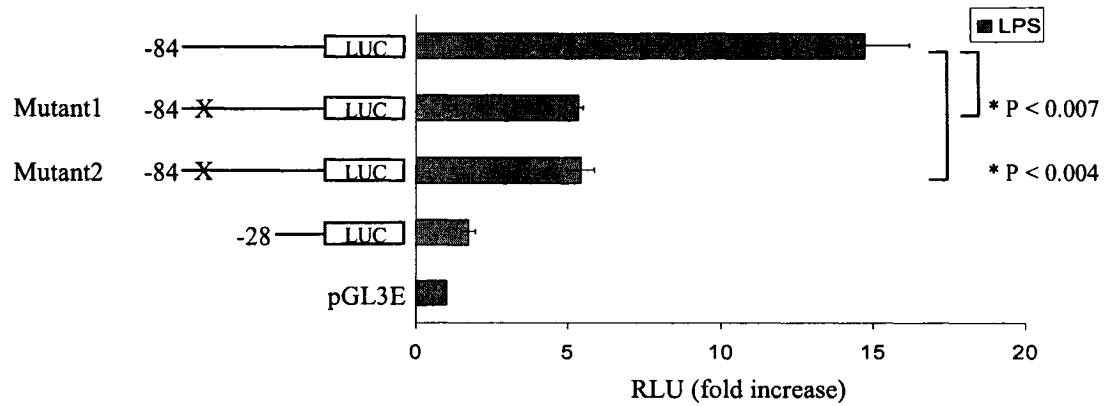
A**B**

transcription factor binding site. To examine the role of IRF-7, I introduced mutations on the IRF-7 binding site by site-directed mutagenesis (Fig 3-10A). The amplified two fragments containing the IRF-7 mutations were cloned into pGL3E. Cells transfected with the mutant plasmids showed significant reduction in luciferase activity when compared to cells transfected with the plasmid containing the un-mutated promoter (Fig. 3-10B). These results suggest that the IRF-7 sequence between -84 to -72 bp of the B7-1 promoter may play a role in the regulation of LPS-induced B7-1 transcription in monocytic cells.

SP600125 down-regulates B7-1 expression by inhibiting IRF-7 activity

The results from the previous experiments demonstrated that LPS-induced B7-1 expression is regulated by the activation of JNK MAPKs (Figs. 3-3, 3-6). To investigate whether LPS-induced B7-1 transcription is regulated by IRF-7 through JNK activation, I examined the effect of SP600125 on B7-1 promoter activity. THP-1/CD14 cells transiently transfected with pB7.1Pr-GL3E containing -84 to +57 bp sequences [pB7.1Pr(-84 to +57)GL3E] were pretreated for 2 hr with SP600125, or as a control, with calphostin C, a PKC inhibitor. As observed above, transfection of cells with pB7.1Pr(-84 to +57)GL3E revealed an approximate 15 fold increase in the luciferase activity in LPS-stimulated cells compared to the cells transfected with the control plasmid (Fig. 3-11). Pretreatment of the same cells with SP600125 significantly decreased the luciferase activity in a dose dependent manner whereas pretreatment with calphostin C did not have any effect (Fig. 3-11). As expected, transfection of cells with pB7.1Pr-GL3E containing

FIGURE 3-11: SP600125 inhibits LPS-mediated B7-1 promoter activity in THP-1/CD14 cells.

THP-1/CD14 cells were cotransfected with 5 μ g of either a promoter construct or vector control and with 2.5 μ g of β -galactosidase control plasmid. The transfected cells were untreated or pretreated with either SP600125, or calphostin C as a control for 2 h followed by stimulation with LPS for 24 hr and measurement of luciferase activity (RLU) as described above. Results shown are a mean \pm S.D. of three independent experiments performed in triplicate.

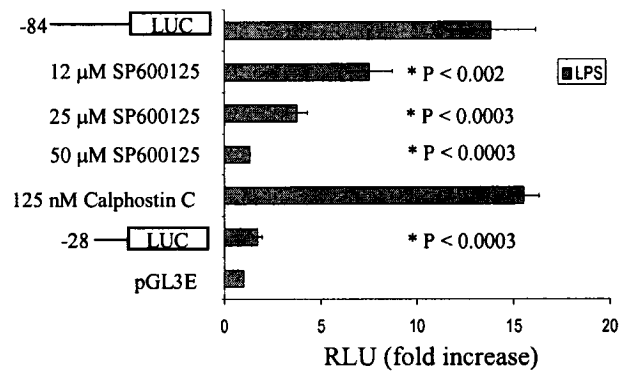

sequences from -28 to +57 bp or pGL3E did not show any increase in luciferase activity upon LPS stimulation. Taken together, the results suggest that SP600125 inhibited LPS-induced B7-1 transcription by inhibiting IRF-7 activity.

SP600125 inhibits IRF-7 binding to the B7-1 promoter in LPS-stimulated THP-1/CD14 cells

To determine the role of JNK in the regulation of B7-1 transcription through the activation of IRF-7, I investigated whether LPS stimulation of THP-1/CD14 cells induced the binding of IRF-7 to its binding site present in the B7-1 promoter by the gel shift assay. Cells were stimulated with LPS over a period of time ranging from 0 to 5 h, and the cytoplasmic and nuclear extracts were analyzed for binding of IRF-7 transcription factors to an oligonucleotide probe corresponding to the IRF-7 binding site in the B7-1 promoter. In cytoplasmic extracts from unstimulated cells, constitutive binding of IRF-7 to the probe in the form of three bands was observed. However, this binding decreased significantly when cytoplasmic extracts obtained at different times after LPS stimulation were used. In contrast, significant binding of IRF-7 to the oligonucleotide probe using nuclear extracts occurred 2–4 h after LPS stimulation (Fig. 3-12A). To determine the specificity of these three bands, cold competition experiments were performed. The binding observed with the upper two bands was completely blocked by competition with their respective cold B7-1 (IRF-7) oligonucleotides. However, the intensity of the lower third band remained unchanged, indicating its nonspecific nature (Fig. 3-12B). Furthermore, cold nonspecific NF- κ B oligonucleotides failed to compete for IRF-7 binding to its labeled oligonucleotide probe (Fig. 3-12B). To determine the specificity of

FIGURE 3-12: LPS stimulation activates an IRF-7 transcription factor which is inhibited by inhibitors of JNK.

(A) THP-1/CD14 cells were stimulated with LPS (1 $\mu\text{g/ml}$) for times ranging from 0 min to 5 h followed by centrifugation and collection of cell pellets. Gel shift assays were performed on the cytoplasmic and nuclear extracts using the IRF-7 B7-1 sequence as a labelled probe. Note: NS refers to non-specific binding.

(B) To determine the specificity of the IRF-7 binding, the nuclear extracts were incubated with cold oligonucleotides (100- to 400-fold) corresponding to the sequence for IRF-7 B7-1, or NF- κ B. Nuclear extracts were also incubated with cold IRF-7 B7-1 oligonucleotide (100- to 400-fold) for 20 minutes followed by incubation with the PRD-I ^{32}P -labeled oligonucleotide. The complexes were subjected to gel shift electrophoresis followed by autoradiography.

(C) To ascertain the effects of the JNK inhibitors on LPS-induced B7-1 activation, THP-1/CD14 cells were treated with various concentrations of SP600125 or DXM for 2 h prior to stimulation with LPS (1 $\mu\text{g/ml}$) for 4 h. Nuclear extracts were incubated for 20 min with ^{32}P -labeled oligonucleotides corresponding to the sequence for IRF-7 B7-1, and gel shift assay performed.

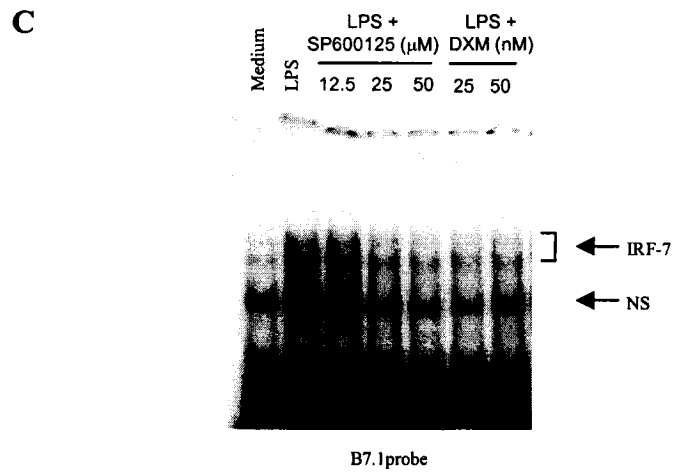
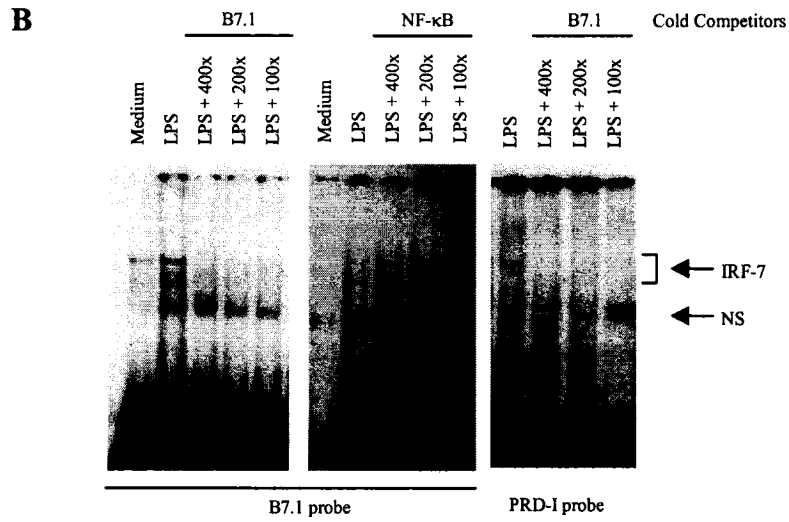
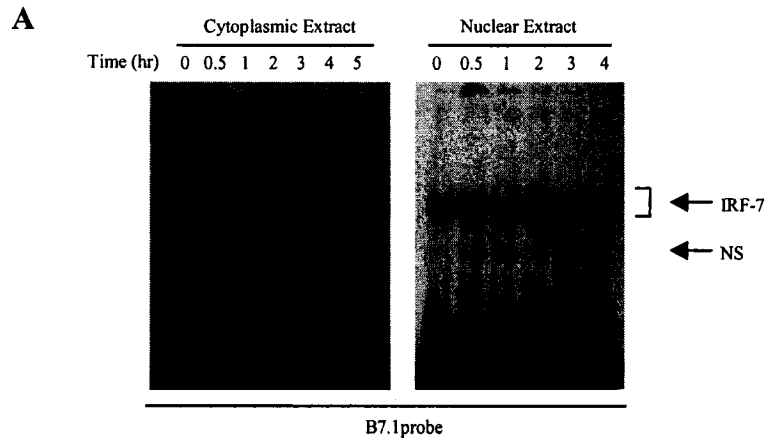

IRF-7 binding, the PRD-I oligonucleotide probe was used as a cold competitor. The PRD-1 oligonucleotide sequence, present in the IFN- β promoter region, specifically binds to IRF-7, but not to IRF-3 transcription factors. DNA gel shift competition analysis using cold B7-1 (IRF-7) oligonucleotides competed for binding with the labeled PRD-I probe (Fig. 3-12B), suggesting the specificity of the top IRF-7 bands.

To determine whether DXM and SP600125 inhibited binding of IRF-7 to its binding site in the B7-1 promoter, cells were treated with SP600125 or DXM for 2 hr prior to LPS stimulation for 4 hr followed by the analysis of IRF-7 binding to its corresponding oligonucleotide probe. The results show that both DXM and SP600125 inhibited the binding of IRF-7 to its oligonucleotide probe in LPS-stimulated THP-1/CD14 cells (Fig. 3-12C). Taken together, the results suggest that B7-1 gene transcription may be regulated by a unique IRF-7 transcription factor(s) through JNK activation.

CHAPTER 4:
STUDIES ON THE REGULATION OF B7-2 IN HUMAN MONOCYTIC CELLS

Introduction

During the past few years, significant progress has been made in elucidating the LPS signaling pathways that induce cytokine expression in monocytes. However, very little is known about the LPS-induced signal transduction pathways involved in the regulation of B7 expression. In this study, we focused on the regulation of B7-2 by the mitogen-activated protein kinases which are key players in cellular responses such as proliferation, differentiation, and apoptosis (116). As mentioned earlier, there are three main families of MAP kinases, namely the extracellular signal-regulated protein kinases (ERK1 and ERK2), the c-Jun N-terminal kinases (JNKs), and the p38 MAP/stress-activated protein kinases (p38 MAPK/SAPKs). ERKs respond to mitogens and growth factors that regulate cell proliferation and differentiation (116) whereas JNK and p38 MAP kinases are predominantly activated by stress and inflammatory cytokines (IL-1 β and TNF- α) (116). LPS has been shown to activate all three types of MAP kinases (116,125,186,187). To understand B7-2 regulation, I employed normal human monocytes and the monocytic cell line, THP-1. I demonstrated that the LPS-induced down-regulation of B7-2 in normal human monocytes is mediated, at least in part, by IL-10, a process that involves activation of p38 MAP kinase. In THP-1 cells, which are refractory to the inhibitory effects of IL-10 and hence show IL-10-independent effects on B7-2 expression, LPS stimulation enhances the expression of B7-2. I further showed that JNK MAP kinases are selectively involved in the IL-10-independent LPS-mediated regulation of B7-2 expression, suggesting a dichotomy in the LPS-induced signaling pathway that regulates B7-2 expression (189).

Results

LPS-induced down-regulation of B7-2 expression in monocytes is mediated by endogenously-produced IL-10.

Unlike the situation with B7-1, it has been previously shown that LPS and IL-10 can down-regulate the expression of B7-2 on human monocytes (25,37,90). I confirmed this by stimulating purified normal human monocytes with 1 $\mu\text{g/ml}$ LPS or 1 ng/ml IL-10 followed by analysis of B7-2 expression by flow cytometry (Fig. 4-1A). To determine whether LPS-mediated down-regulation of B7-2 is due to endogenously produced IL-10, neutralizing anti-IL-10 antibodies were added for two hr prior to LPS stimulation. The anti-IL-10 antibodies abrogated LPS-mediated B7-2 down-regulation (Fig. 4-1A) suggesting the involvement of IL-10 in LPS-induced down-regulation of B7-2 expression. LPS and IL-10 were also shown to down-regulate B7-2 mRNA expression in purified human monocytes as determined by semi-quantitative RT-PCR analysis (Fig. 4-1B).

FIGURE 4-1: LPS and IL-10 down-regulate B7-2 expression in purified human monocytes.

(A) Purified human monocytes (1×10^6 /ml) were stimulated with LPS (1 μ g/ml) or IL-10 (1 ng/ml). Cells were treated with neutralizing anti-IL-10 antibodies (10 μ g/ml) or isotype-matched control antibodies (10 μ g/ml) for 2 hr prior to stimulation with LPS (1 μ g/ml). Cells were cultured for 48 hr and analyzed by flow cytometry for B7-2 expression. Shaded area represents autofluorescence. The experiment shown is representative of three experiments.

(B) Monocytic cells were stimulated with LPS (1 μ g/ml) or IL-10 (1 ng/ml) for 0 to 10 h and the cells were harvested for mRNA isolation. B7-2 expression was determined by semiquantitative reverse transcriptase-based PCR (RT-PCR) analysis using β -actin as a standard control. The experiment shown is representative of three experiments.

A

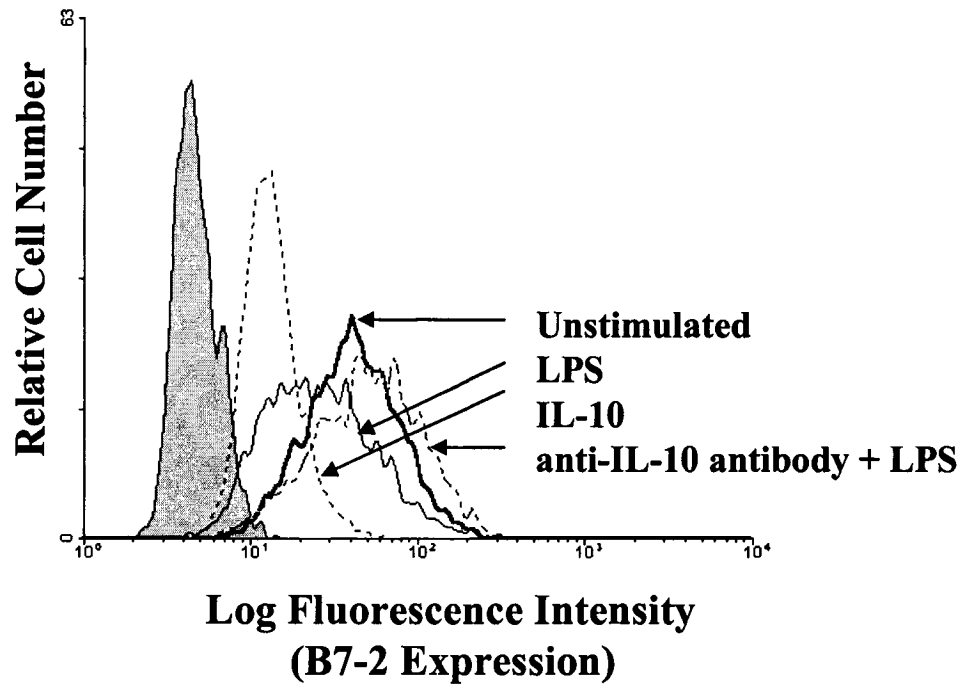

B

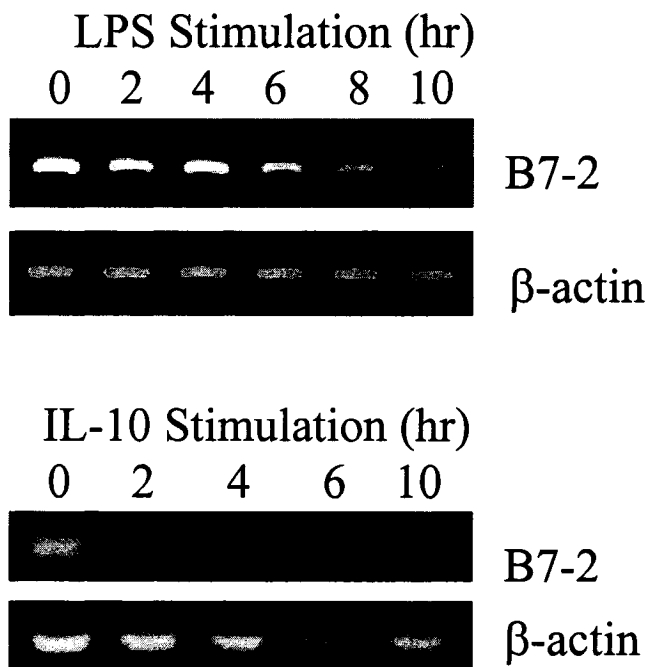

Role of p38 MAP kinase in the LPS-mediated down-regulation of B7-2 expression

To understand the molecular mechanism underlying the regulation of B7-2 expression by LPS, I investigated the role of MAP kinase family members as these have been shown to play a key role in the LPS-induced expression of several cytokines including IL-10 (125,127,190). I first addressed the involvement of p38 and p42/44 ERK kinases by examining their activation in LPS-stimulated normal human monocytes. LPS induced the phosphorylation of both p38 and ERK kinases (Fig. 4-2A). The role of p38 and p42/44 ERK kinases has been studied through the use of specific inhibitors. SB202190 is a selective and potent inhibitor of p38 MAP kinase, and has no effect on the activity of the ERK or JNK MAP kinase subgroups (116,124). Similarly, PD98059, a potent and specific inhibitor of ERKs, mediates its effects by inactivating the ERKs without affecting the activity of either p38 or JNK MAP kinases (116,172). To confirm that SB202190 and PD98059 specifically inhibited the phosphorylation of p38 and ERKs respectively in our system, freshly isolated monocytes were pretreated with these inhibitors for two hr followed by stimulation with LPS for 15 min. The results show that in LPS-induced cell lysates, SB202190 inhibited the phosphorylation of p38 MAP kinase, and that PD98059 inhibited the activation of ERKs in a dose dependent manner (Fig. 4-2A).

To determine the role of p38 and p42/44 MAP kinases in LPS-mediated down-regulation of B7-2, monocytes were treated with SB202190 or PD98059 for two hr before stimulation with LPS and analyzed for B7-2 expression. SB202190 prevented the

LPS-mediated down-regulation of B7-2 expression in a dose-dependent manner. In contrast, PD98059 did not have any effect at any of the concentrations tested (Fig. 4-2B).

Role of p38 MAP kinase in LPS-induced IL-10 production

It has been previously shown that p38 MAP kinase regulates LPS-induced IL-10 production in monocytes/macrophages (127,174). Therefore, it is likely that the down-regulation of B7-2 expression by p38 MAP kinase inhibitor SB202190 may be due to the blockade of endogenously-produced IL-10. To investigate this possibility, cells were pretreated with either SB202190 or PD98059, and IL-10 synthesis was measured by ELISA. SB202190 inhibited LPS-induced IL-10 production whereas PD98059 had no effect (Fig. 4-2C) indicating a role for the p38, but not the p42/44 ERKs, in the regulation of IL-10 expression. These results further support my previous observations that the down-regulation of B7-2 expression in LPS-stimulated monocytes may be mediated, at least in part, by endogenously-produced IL-10 (91).

FIGURE 4-2: LPS stimulation induces p38 and p42/44 MAP kinase phosphorylation in purified human monocytes.

(A) Purified human monocytes ($1 \times 10^6/\text{ml}$) were treated with various doses of SB202190 Or PD98059 for 2 hr. Cells were then stimulated with LPS ($1 \mu\text{g}/\text{ml}$) for 15 min, followed by centrifugation and lysis of cell pellets. Proteins from the cell lysates were subjected to SDS-PAGE followed by transfer of proteins onto the membranes. The membranes were blotted with anti-phospho-p38 and anti-phospho-p42/44 rabbit polyclonal antibodies. To control for protein loading, the membranes were stripped and reprobed with anti-p38 and anti-p42/44 rabbit polyclonal antibodies (left panel). To quantify the relative changes in the phosphorylation status of p38 and p42/44 MAP kinases, densitometry was performed (right panel). The experiment shown is representative of a minimum of three experiments.

p38 MAP kinase inhibitor prevents LPS-mediated down-regulation of B7-2 expression (B) and IL-10 production (C) in normal human monocytes.

Monocytes ($1 \times 10^6/\text{ml}$) were treated with various concentrations of SB202190 (0.078 to $50 \mu\text{M}$) or with various concentrations of PD98059 (5.0 to $50 \mu\text{M}$) for 2 hr prior to stimulation with LPS. After 48 hr, cells were analyzed by flow cytometry for B7-2 expression (B). Cell supernatants were also harvested and analyzed by ELISA for IL-10 production (C). The experiment shown is representative of three experiments.

A

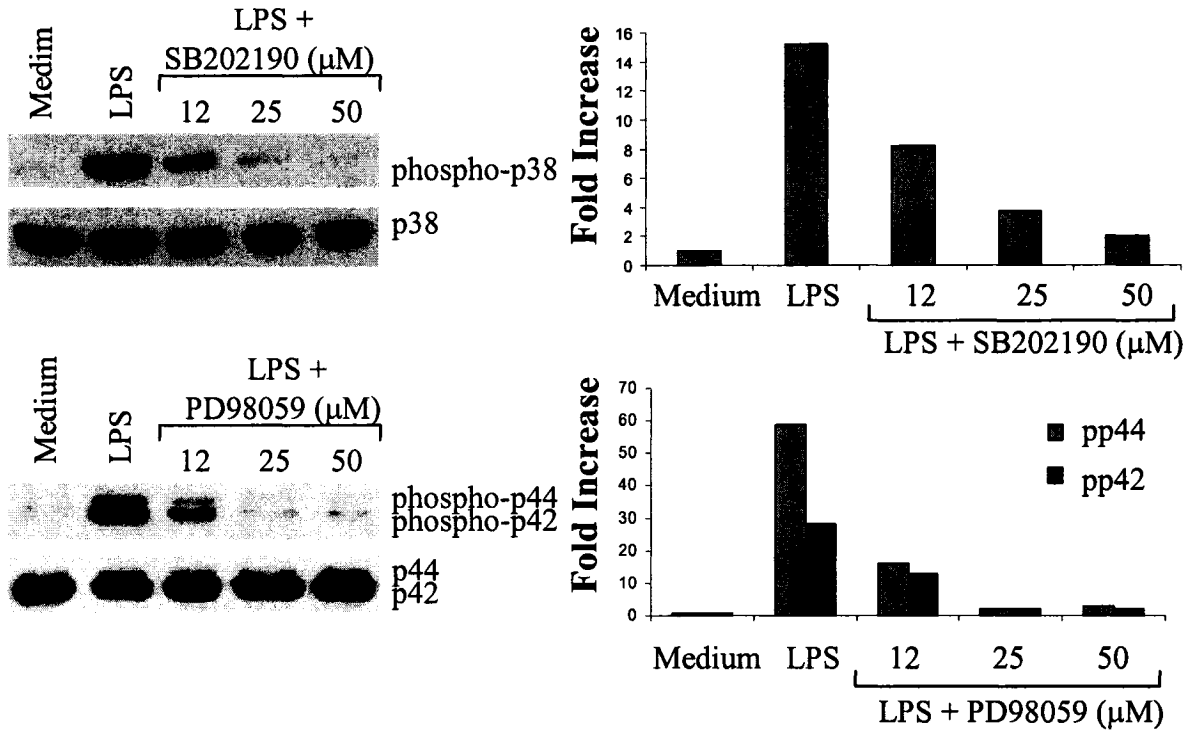

B

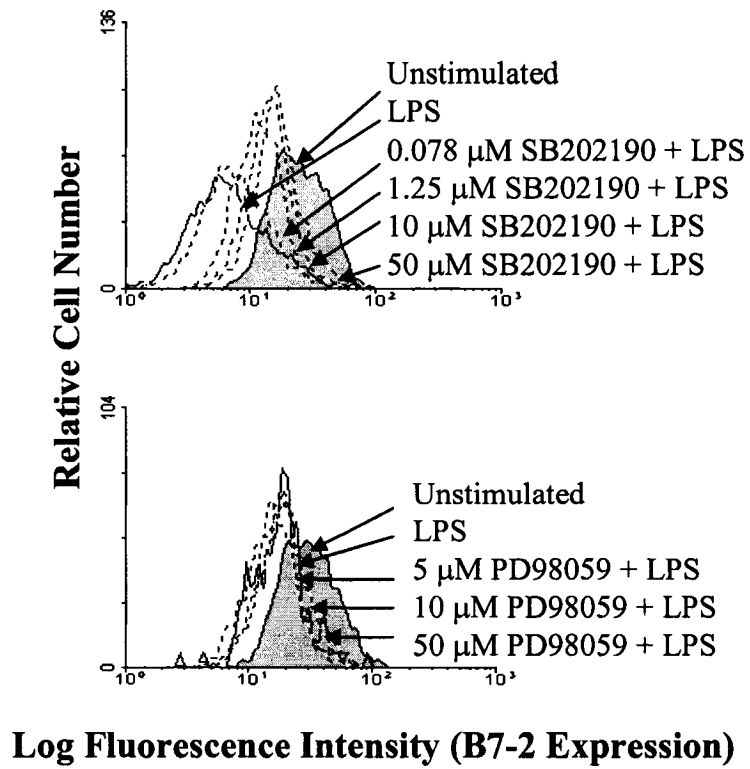

C

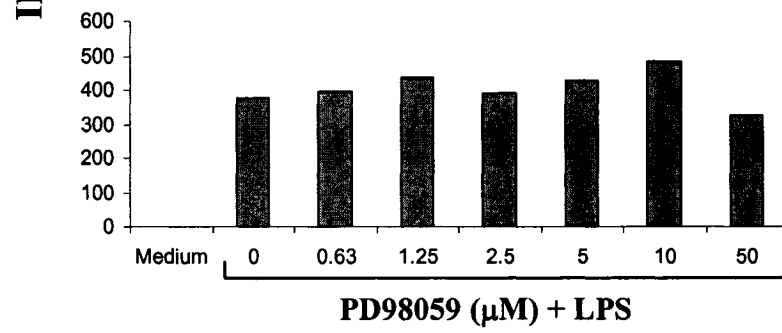
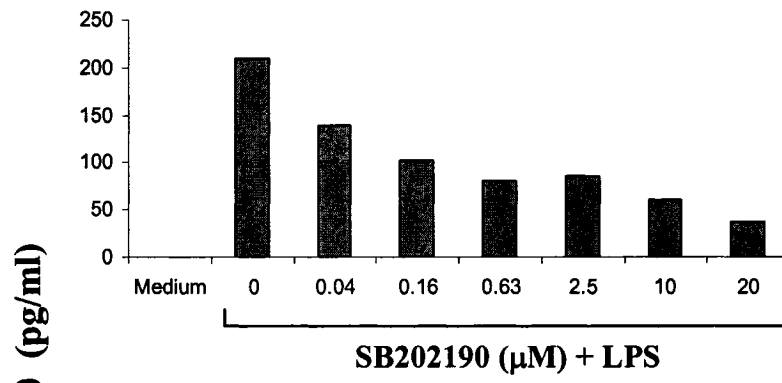

IL-10-mediated down-regulation of B7-2 expression does not involve activation of p38 or ERKs

It is likely that IL-10 induced by LPS stimulation of monocytes may also inhibit B7-2 expression by activating p38 or ERK MAP kinases. To explore this possibility, the phosphorylation of p38 or ERKs as well as the effects of their inhibitors on B7-2 expression in response to IL-10 was studied. The results show that IL-10 enhanced the phosphorylation of p42/44 ERK kinase and pretreatment of monocytes with PD98059 prior to IL-10 stimulation dramatically reduced its phosphorylation in a dose dependent manner (Fig. 4-3A). In contrast, IL-10 stimulation of monocytes did not enhance the phosphorylation of p38 MAP kinase and pretreatment with SB202190 did not significantly influence the phosphorylation of p38 MAP kinase (Fig 4-3A). To further determine if IL-10 mediated down-regulation of B7-2 in human monocytes utilized the p38 and ERK MAP kinases, cells were incubated with SB202190 or PD98059 prior to stimulation with IL-10. The results clearly show that neither SB202190 nor PD98059 inhibited IL-10-mediated down-regulation of B7-2 (Fig. 4-3B) and suggest that activation of either p38 or p42/44 MAP kinase may not be involved in IL-10-mediated down regulation of B7-2 expression.

To confirm the role of p38 MAP kinase in IL-10 dependent B7-2 regulation, I investigated whether B7-2 down regulation observed in LPS-stimulated cells is mediated by the endogenously produced IL-10 via the activation of p38 MAP kinase. This was determined by analysis of B7-2 expression in LPS-stimulated cells exhibiting blockage of IL-10 production by p38 MAP kinase inhibitor SB202190 and reconstituted with graded

FIGURE 4-3: (A) Effect of IL-10 on p38 and p42/44 MAP kinase phosphorylation in purified human monocytes.

Purified human monocytes (1×10^6 /ml) were treated with SB202190 (50 μ M) or various doses of PD98059 for 2 hr. Cells were then stimulated with IL-10 (1 ng/ml) for 15 min. Total cell proteins were analyzed for phosphorylation of p38 and p42/44 MAP kinases using anti-phospho-p38 and anti-phospho-p42/44 rabbit polyclonal antibodies. To control for protein loading, the membranes were stripped and reprobed with anti-p38 and anti-p42/44 rabbit polyclonal antibodies (left panel). To quantify the relative changes in the phosphorylation status of p38 and p42/44 MAP kinases, densitometry was performed (right panel). The experiment shown is representative of three experiments.

(B) p38 and p42/44 MAP kinase inhibitors do not prevent IL-10-mediated down regulation of B7-2 expression in normal human monocytes.

Monocytes (1×10^6 /ml) were treated with 50 μ M of either SB202190 or PD98059 for 2 hr prior to stimulation with IL-10. After 48 hr, cells were analyzed by flow cytometry for the expression of B7-2. The experiment shown is representative of three experiments.

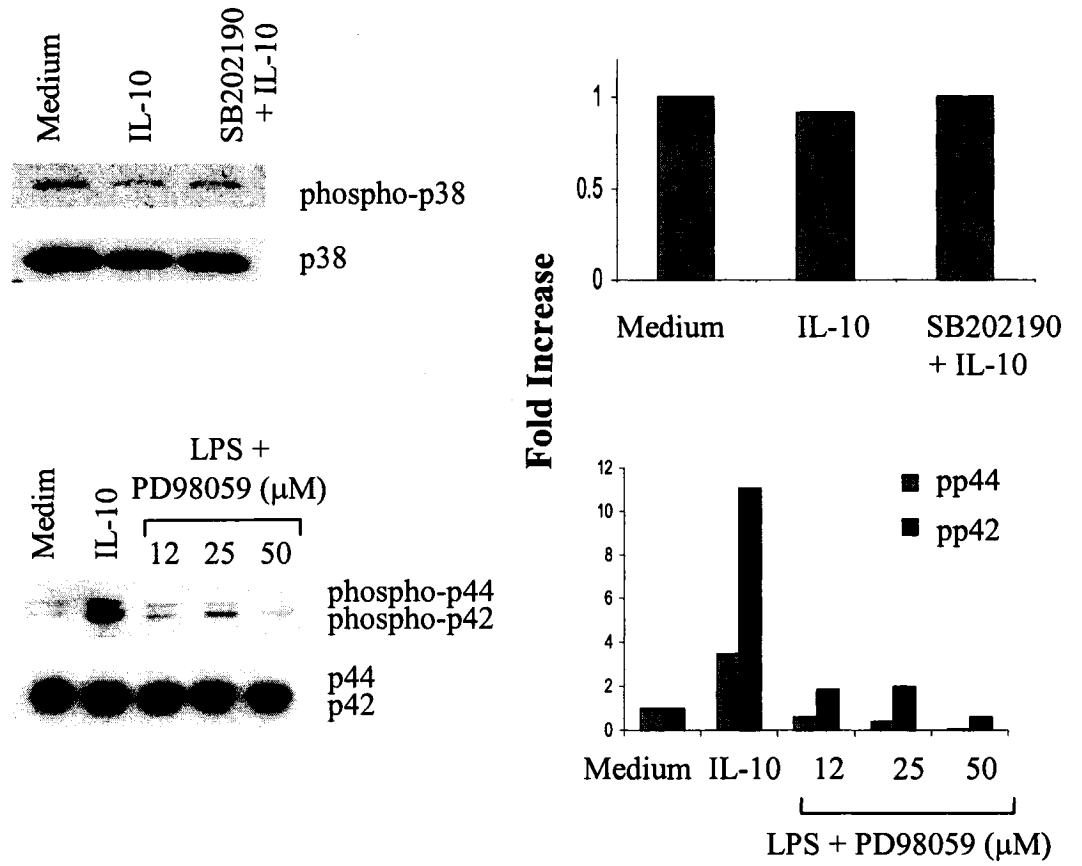
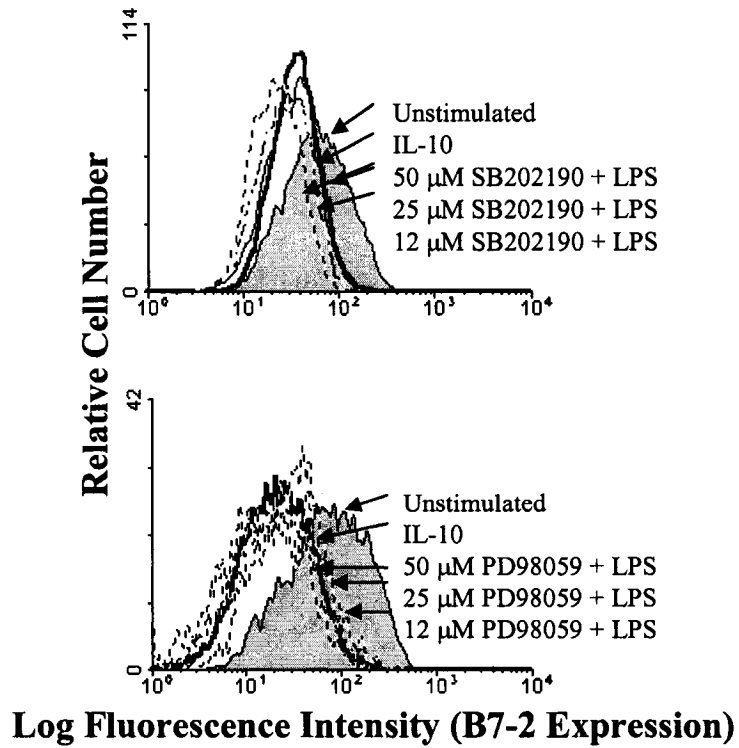
A**B**

doses of recombinant human IL-10. Monocytes were treated with SB202190 for 2 hrs prior to stimulation with LPS in the presence and in the absence of varying concentrations of IL-10 (0.1 to 5 ng/ml). After 48 hr, monocytes were analyzed for B7-2 expression by flow cytometry and the supernatants were analyzed for IL-10 production by ELISA. The results show that SB202190 inhibited IL-10 production (210 pgs/ml of IL-10 in LPS-stimulated monocytes versus 30 pg/ml in LPS-stimulated cells pretreated with 25 μ M of SB202190) as well as reversed the LPS-mediated down regulation of B7-2. Exogenous addition of IL-10 to SB202190-treated and LPS-stimulated monocytic cells reversed the SB202190-induced reconstitution of B7-2 expression in a dose dependent manner (Table 4-1; Fig. 4-4). Taken together, these results suggest that activation of p38 MAP kinase is required for the IL-10 production in response to LPS stimulation and blockade of IL-10 production by p38 MAP kinase inhibitor SB202190 reverses the inhibitory effect of endogenously produced IL-10 on B7-2 expression. On the other hand, p38 MAP kinase may not regulate the IL-10-mediated down regulation of B7-2 expression.

FIGURE 4-4: Exogenous addition of human recombinant IL-10 reverses the SB202190-induced effect of B7-2 expression in SB202190 pretreated LPS-stimulated monocytes.

Purified human monocytes (1×10^6 /ml) were pretreated with 25 μ M of SB202190 for 2 hr prior to stimulation with LPS (1 μ g/ml) in the presence and in the absence of varying concentration of recombinant human IL-10. After 48 hr, the cells were analyzed for B7-2 expression by flow cytometry and the supernatants were analyzed for IL-10 production by ELISA. SB202190 inhibited LPS-induced IL-10 production (210 pg/ml of IL-10 in LPS-stimulated monocytes versus 30 pg/ml in SB202190 treated and LPS-stimulated monocytes). The results shown are representative of three experiments performed.

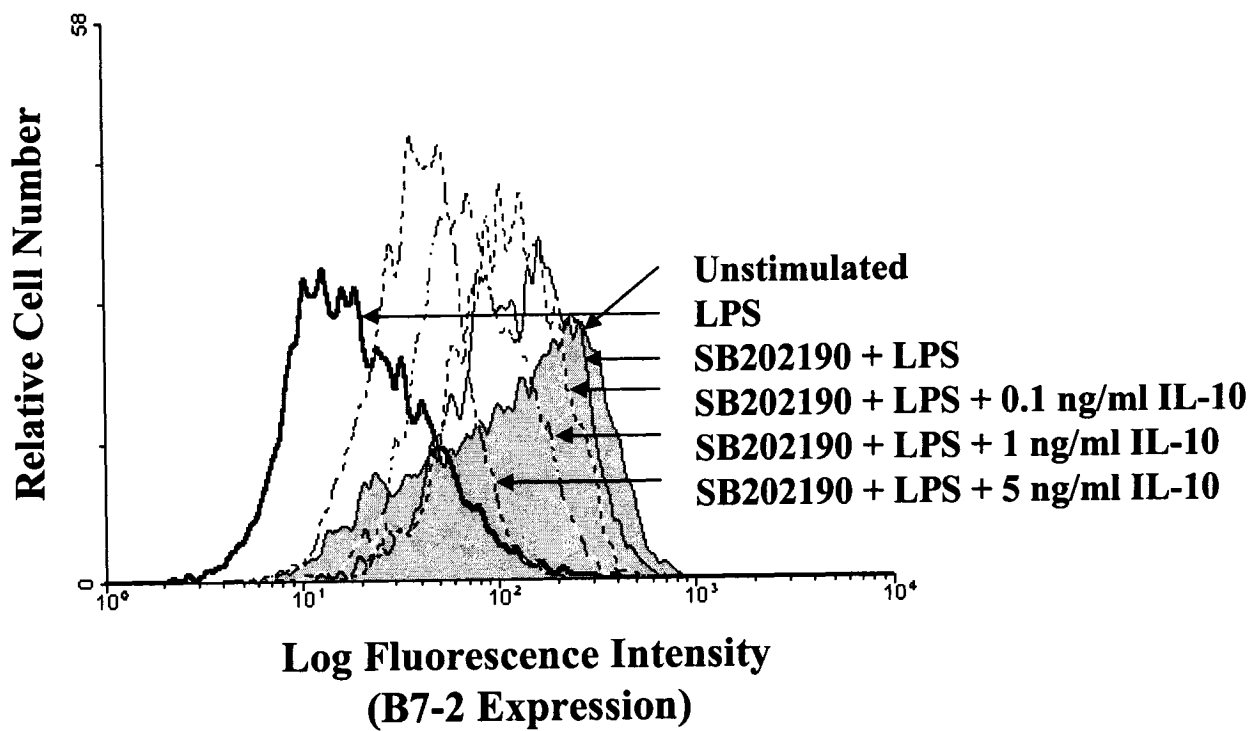

TABLE 4-1: Effect of human recombinant IL-10 on B7-2 expression in SB202190 pretreated LPS-stimulated monocytes.

Monocyte Treatment	Mean Channel Fluorescence
Unstimulated	162
LPS	24
SB202190 + LPS	157
SB202190 + LPS + 0.01 ng/ml IL-10	147
SB202190 + LPS + 0.1 ng/ml IL-10	135
SB202190 + LPS + 1 ng/ml IL-10	91
SB202190 + LPS + 2 ng/ml IL-10	68
SB202190 + LPS + 5 ng/ml IL-10	50
SB202190 + LPS + 10 ng/ml IL-10	46

Purified human monocytes (1×10^6 /ml) were pretreated with 25 μ M of SB202190 for 2 hr prior to stimulation with LPS (1 μ g/ml) in the presence and in the absence of varying concentration of recombinant human IL-10. After 48 hr, the cells were analyzed for B7-2 expression by flow cytometry and the supernatants were analyzed for IL-10 production by ELISA. SB202190 inhibited LPS-induced IL-10 production (210 pg/ml of IL-10 in LPS-stimulated monocytes versus 30 pg/ml in SB202190 treated and LPS-stimulated monocytes). The results shown are representative of three experiments performed.

LPS stimulation induces B7-2 expression in THP-1 cells

LPS-induced down-regulation of B7-2 expression in normal human monocytes is complex and is subject to regulation by signaling in response to interactions between IL-10 and its receptor, and between LPS and CD14. To determine the contribution of MAP kinases in IL-10-independent LPS-induced B7-2 expression, I employed the THP-1 promonocytic cell line since these cells did not respond to IL-10 stimulation. Five to fifteen percent of THP-1 cells express CD14, and following LPS-stimulation, the level of CD14 expression is increased to approximately fifty percent. In THP-1 cells, IL-10 did not influence B7-2 expression, whereas LPS stimulation enhanced B7-2 expression (Fig. 4-5A). These results suggest that THP-1 cells are refractory to the inhibitory effects of IL-10, and that LPS stimulation, contrary to what occurs in normal human monocytes, enhances B7-2 expression in the absence of IL-10-mediated effects. LPS was also shown to up-regulate B7-2 mRNA expression in THP-1 cells as determined by semi-quantitative RT-PCR analysis (Fig. 4-5B).

FIGURE 4-5: LPS induces B7-2 expression in THP-1 cells.

(A) THP-1 cells (1×10^6 /ml) were stimulated with LPS ($1 \mu\text{g/ml}$) or IL-10 (1 ng/ml). Cells were cultured for 48 hr followed by flow cytometric analysis of B7-2 expression. Shaded area represents autofluorescence.

(B) THP-1 cells (1×10^6 /ml) were stimulated with LPS ($1 \mu\text{g/ml}$) for times ranging from 0 to 20 h following which the cells were harvested for mRNA isolation. B7-2 expression was determined by semiquantitative RT-PCR analysis using β -actin as a standard control. The experiment shown is representative of three experiments.

A

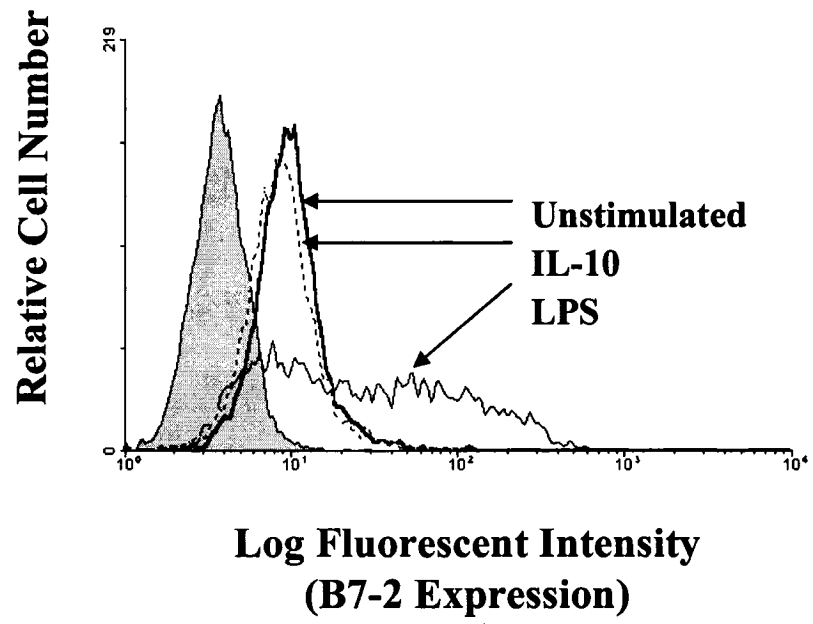

B

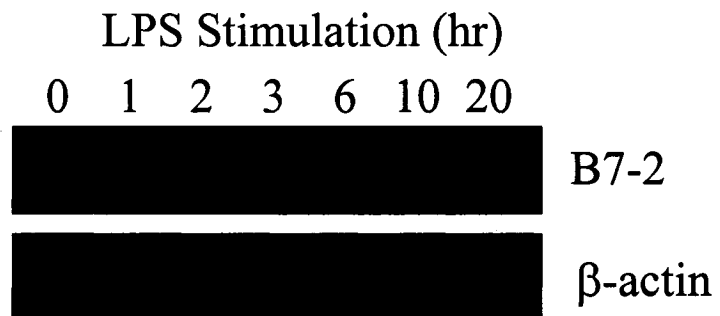

p38 and ERK MAP kinases do not influence LPS-induced IL-10-independent B7-2 expression in THP-1 cells

To investigate the role of ERK and p38 MAP kinases in the LPS-mediated upregulation of B7-2 in THP-1 cells, I first examined whether SB202190 or PD98059 specifically inhibited the phosphorylation of p38 and ERK kinases, respectively. LPS-induced phosphorylation of p38 was inhibited by SB202190 as was the LPS-induced phosphorylation of ERK kinase by PD98059 (Fig. 4-6A). To determine the role of p38 and ERK MAP kinase pathways in LPS-induced B7-2 expression, THP-1 cells were treated with SB202190 or PD98059 for two hr prior to stimulation with LPS. Neither inhibitor affected the LPS-mediated upregulation of B7-2 expression at any of the concentrations tested (Fig. 4-6B).

Role of JNK in LPS-mediated IL-10-independent expression of B7-2 in THP-1 cells

Since p38 and ERK kinases were not found to be involved in the regulation of LPS-induced B7-2 expression, I examined the role of JNK kinase, the third major member of the MAP kinase family. To determine the involvement of JNK in the regulation of B7-2 expression, I took advantage of the fact that glucocorticoids (dexamethasone) inhibit JNK MAP kinase activation (188,191). I examined whether LPS stimulation of THP-1 cells could result in tyrosine phosphorylation of JNK, and whether dexamethasone or SP600125 could inhibit its phosphorylation. LPS stimulation enhanced JNK phosphorylation that was inhibited by dexamethasone and SP600125 (Fig. 4-7A,C). To determine the effect of dexamethasone or SP600125 on LPS-induced B7-2 expression, THP-1 cells were pretreated with dexamethasone or SP-600125 for 2 hr prior

FIGURE 4-6: (A) LPS stimulation induces p38 and p42/44 MAP kinase phosphorylation in THP-1 cells.

THP-1 cells (1×10^6 /ml) were treated for 2 hr with various doses of SB202190 or PD98059. Cells were then stimulated with LPS ($1 \mu\text{g/ml}$) for 15 min. Total cell proteins were analyzed for phosphorylation of p38 MAP kinases using anti-phospho-p38 rabbit polyclonal antibodies. For analysis of p42/44 ERKs, cell lysates were immunoprecipitated with rabbit anti-p42 antibodies. The phosphorylated p42 ERK was detected by using 4G10 anti-phosphotyrosine antibodies. To control for protein loading, the membranes were stripped and reprobed with anti-p38 and anti-p42 ERK rabbit polyclonal antibodies (left panel). To quantify the relative changes in the phosphorylation status of p38 and p42/44 MAP kinases, densitometry was performed (right panel). The experiment shown is representative of three experiments.

(B) p38 and p42/44 MAP kinase inhibitors do not prevent LPS-mediated upregulation of B7-2 expression in THP-1 cells.

Cells (1×10^6 /ml) were treated with various concentrations of either SB202190 (6.25 to 50 μM) or PD98059 (12.5 to 50 μM) for 2 hr prior to stimulation with LPS. After 48 hr, cells were analyzed by flow cytometry for the expression of B7-2. The experiment shown is representative of three experiments.

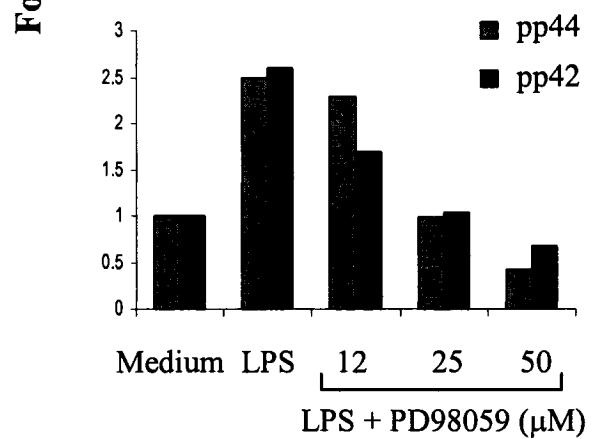
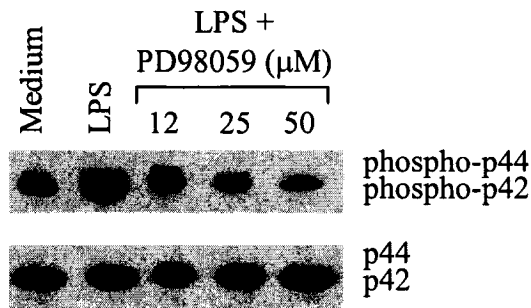
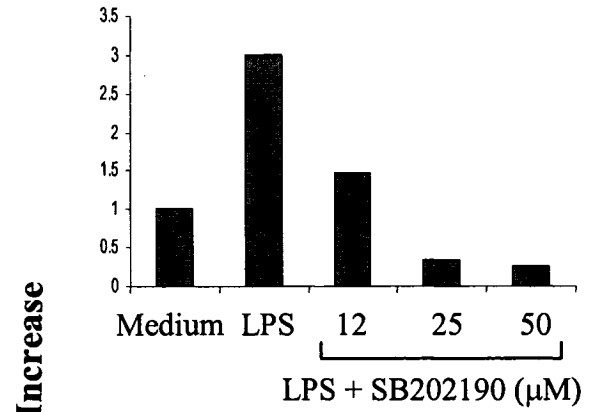
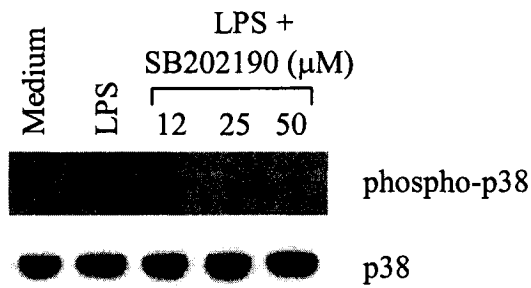
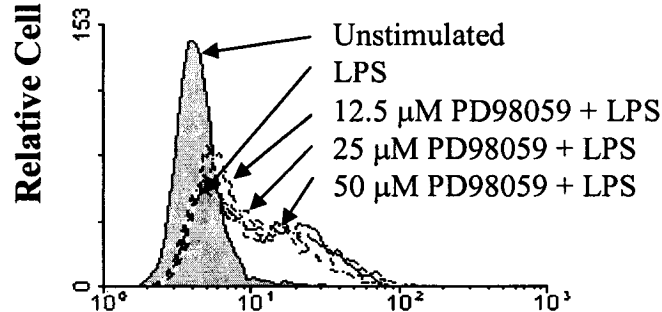
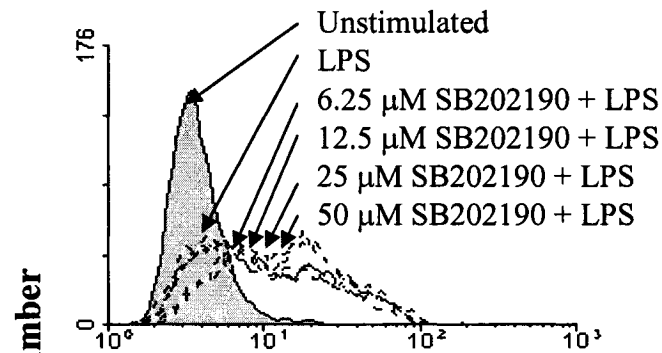
A**B****Log Fluorescence Intensity (B7-2 Expression)**

to stimulation with LPS. Dexamethasone inhibited B7-2 expression in THP-1 cells at concentrations as low as 2 nM and maximum inhibition was observed at 20 nM (Fig. 4-7B); whereas SP600125 inhibited B7-2 expression at 12 μ M (Fig. 4-7C).

Similar results with respect to the effects of dexamethasone and SP600125 on LPS-mediated B7-2 regulation were also observed in normal human monocytes. LPS stimulation induced JNK phosphorylation that was inhibited by dexamethasone and SP600125 (Fig. 4-8A,D). As was observed for THP-1 cells, dexamethasone and SP600125 inhibited LPS-mediated down-regulation of B7-2 expression in normal human monocytes in a dose-dependent manner (Fig. 4-8B,D). Furthermore, in contrast to SB202190 (Fig. 4-2), dexamethasone did not inhibit LPS-induced IL-10 production even when used at high concentrations (Fig. 4-8C). These results suggest that dexamethasone inhibited LPS-mediated down-regulation of B7-2 expression in monocytes independently of endogenously-produced IL-10 and implicates JNK in LPS-mediated B7-2 expression in monocytes as well as in THP-1 cells.

FIGURE 4-7: (A) Dexamethasone inhibits LPS-induced phosphorylation of JNK kinase in THP-1 cells.

THP-1 cells (1×10^6 /ml) were treated with dexamethasone (100 nM) for 2 hr prior to stimulation with LPS (1 μ g/ml) for 15 min. Total cell proteins were analyzed for phosphorylation of JNK MAP kinase using anti-phospho-JNK rabbit polyclonal antibody. To control for protein loading, the membranes were stripped and reprobbed with anti-JNK rabbit polyclonal antibodies (left panel). To quantify the relative changes in the phosphorylation status of JNK, densitometry was performed (right panel). The experiment shown is representative of three experiments.

(B) Dexamethasone inhibits LPS-mediated B7-2 expression in THP-1 cells.

Cells (1×10^6 /ml) were treated with various concentrations of dexamethasone ranging from 2.0 to 200 nM for 2 hr prior to stimulation with LPS followed by flow cytometric analysis of B7-2 expression. The experiment shown is representative of three experiments.

(C) SP600125 inhibits LPS-induced phosphorylation of JNK kinase and LPS-mediated B7-2 expression in THP-1 cells.

THP-1 cells (1×10^6 /ml) were treated with SP600125 for 2 hr prior to stimulation with LPS (1 μ g/ml) for 15 min for JNK immunoblot analysis; and 48 hr for flow cytometric analysis of B7-2 expression.

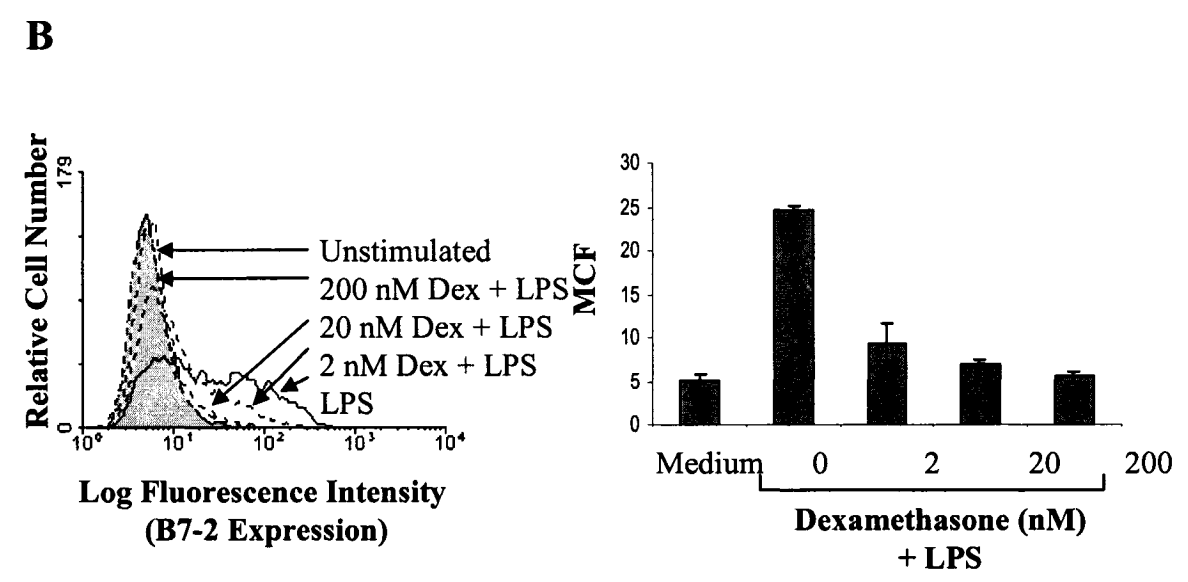
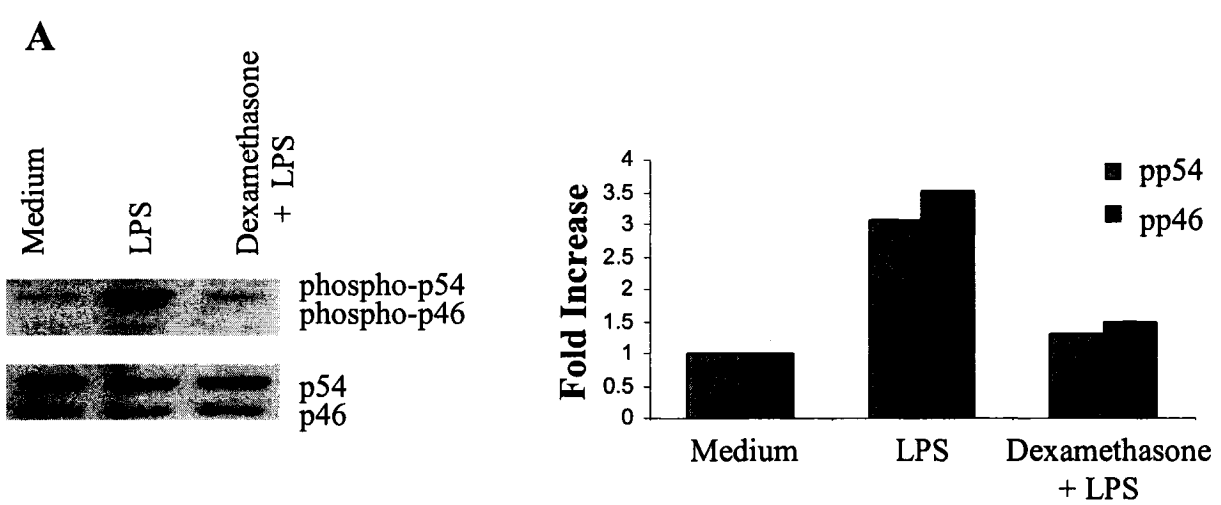

C

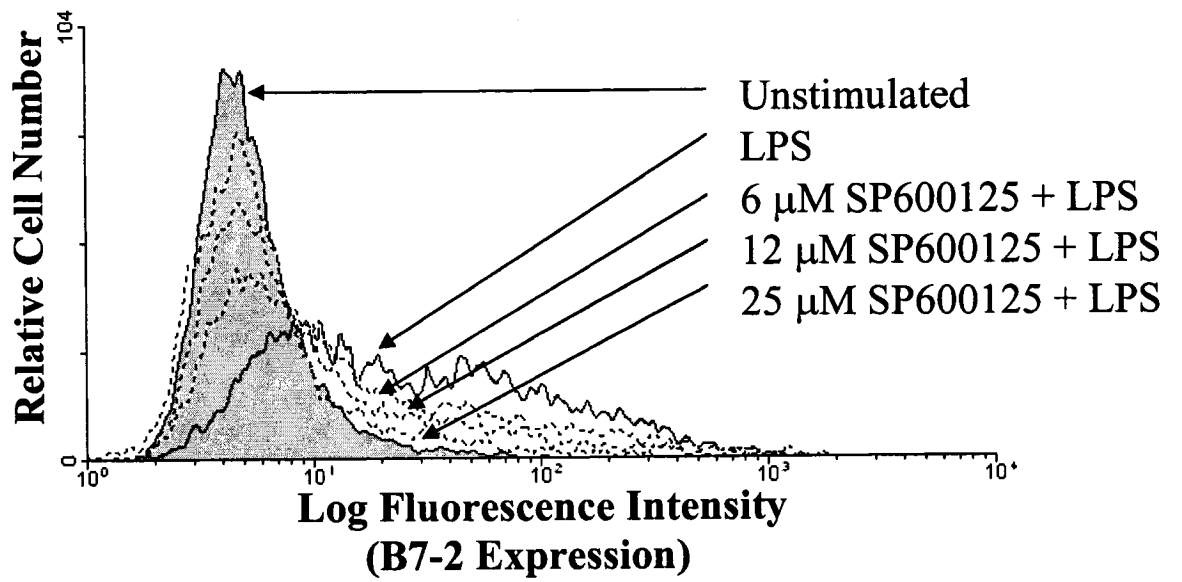
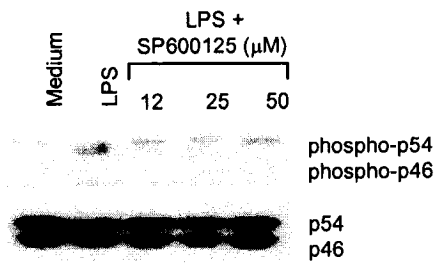

FIGURE 4-8: (A) Dexamethasone inhibits LPS-induced phosphorylation of JNK kinase in purified human monocytes.

Purified human monocytes (1×10^6 /ml) were treated with dexamethasone (100 nM) for 2 hr prior to stimulation with LPS (1 μ g/ml) for 15 min. Total cell proteins were analyzed for phosphorylation of JNK MAP kinase using anti-phospho-JNK rabbit polyclonal antibody. To control for protein loading, the membranes were stripped and reprobed with anti-JNK rabbit polyclonal antibodies (left panel). To quantify the relative changes in the phosphorylation status of JNK, densitometry was performed (right panel). The experiment shown is representative of three experiments.

(B) Dexamethasone prevents inhibition of LPS-mediated down regulation of B7-2 expression in monocytes.

Cells (1×10^6 /ml) were treated with various concentrations of dexamethasone ranging from 1.0 to 100 nM for 2 hr prior to stimulation with LPS followed by analysis of B7-2 expression by flow cytometry. The experiment shown is representative of three experiments.

(C) Dexamethasone does not inhibit LPS-induced IL-10 production in monocytes.

Cells (1×10^6 /ml) were treated with various concentrations of dexamethasone (ranging up to 1000 nM) for 2 hr prior to stimulation with LPS. After 48 hr of stimulation, IL-10 production in the supernatants was measured by ELISA. The experiment shown is representative of three experiments.

(D) SP600125 inhibits LPS-induced phosphorylation of JNK kinase and LPS-mediated down regulation of B7-2 expression in purified human monocytes.

Monocytic cells (1×10^6 /ml) were treated with SP600125 for 2 hr prior to stimulation with LPS (1 μ g/ml) for 15 min for JNK immunoblot analysis; and 48 hr for flow cytometric analysis of B7-2 expression.

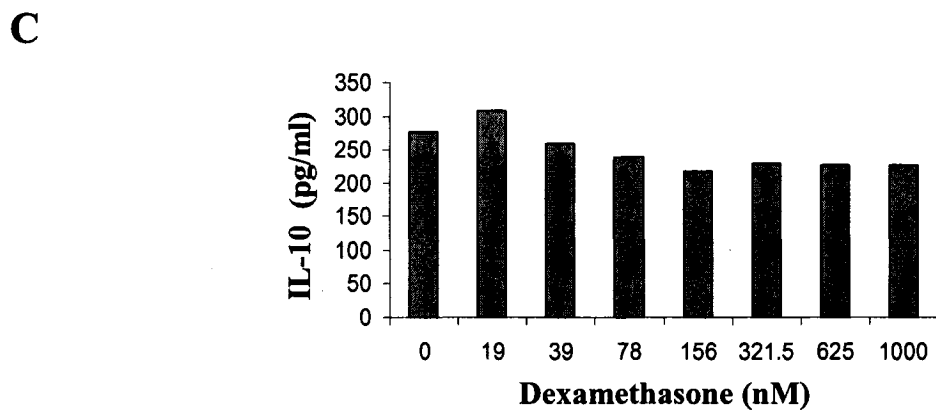
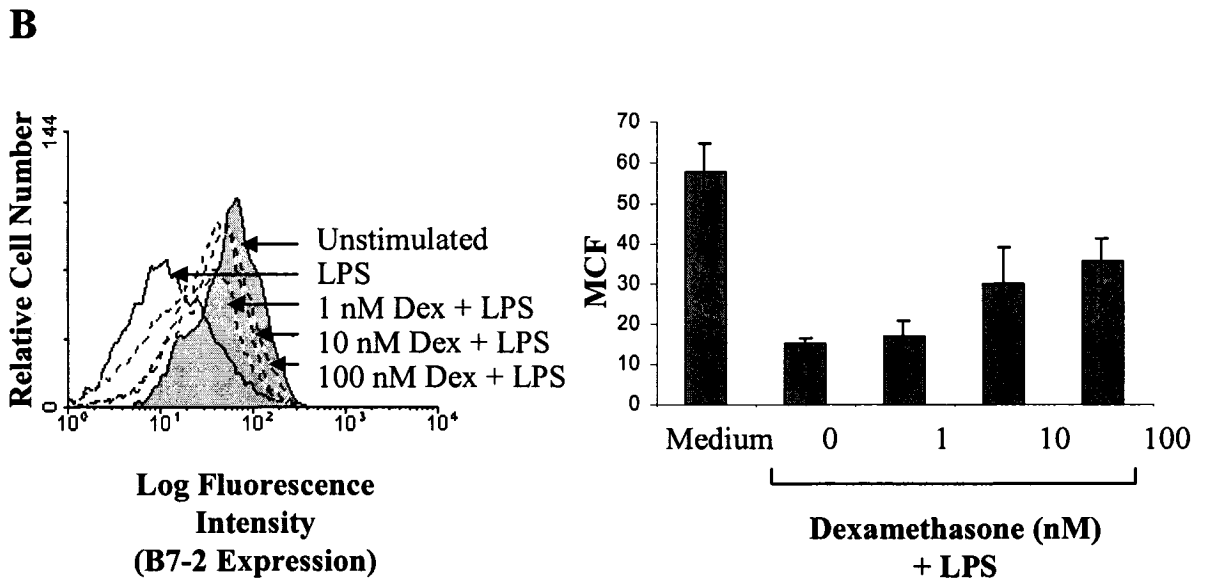
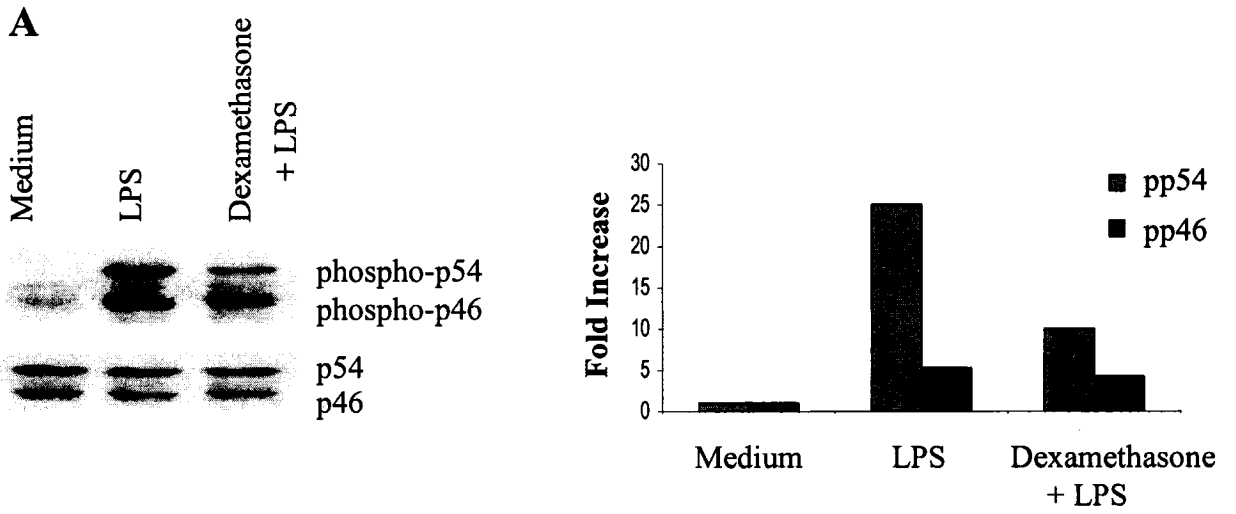

D

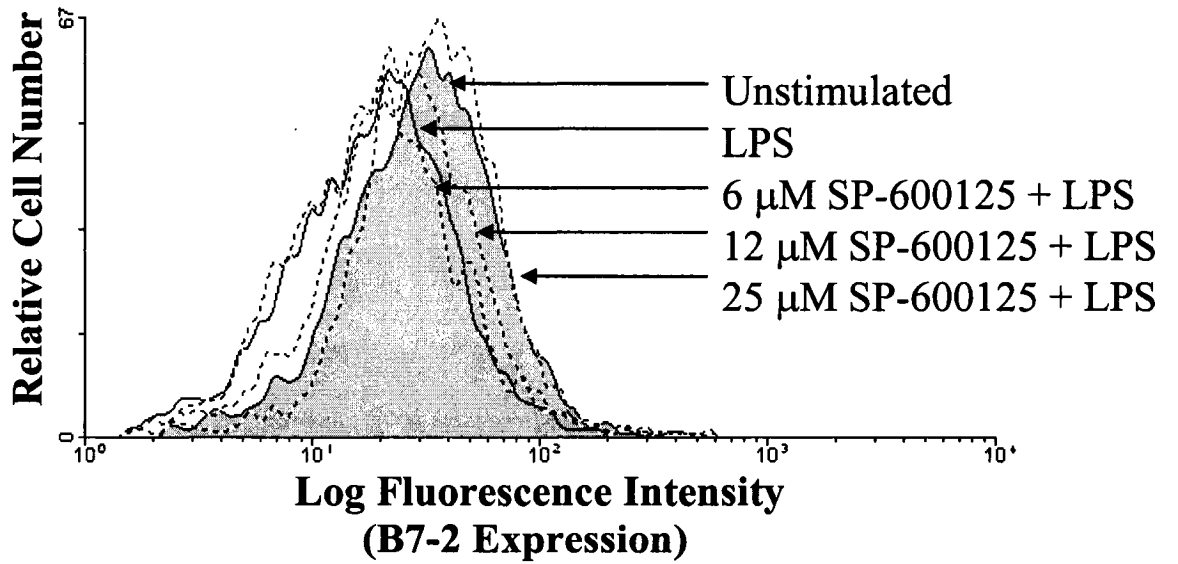
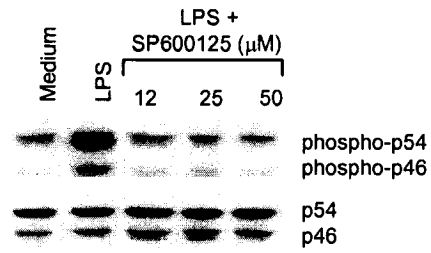

Dominant-negative SEK1 (MKK4) kinase inhibits B7-2 expression in LPS-stimulated THP-1 cells

To confirm the role of the JNK pathway in B7-2 expression, THP-1 cells were transfected with either a plasmid expressing a dominant-negative (DN) SEK1 kinase mutant or with a control plasmid (pcDNA3). JNK is a cellular target of SEK1 kinase and the expression of the DN SEK1 will interfere with the phosphorylation of JNK (192-194). LPS stimulation of THP-1 cells transfected with the DN SEK1 failed to induce the phosphorylation of JNK kinase in contrast to cells transfected with the control plasmid (Fig. 4-9A). THP-1 cells transfected for 12 hr with either the DN SEK1 or the control plasmids, were stimulated with LPS and analyzed for B7-2 expression. B7-2 expression was dramatically reduced in DN-SEK1 transfected cells compared to the cells transfected with the control plasmid (Fig. 4-9B). The effect of transfection of THP-1 cells with DN SEK1 on B7-2 expression was selective since the expression of CD14 on their surface membrane remained unaffected (Fig. 4-9B). The optimal time period of 12 hr post-transfection and prior to LPS-stimulation was chosen based on the results of a series of experiments in which cells were stimulated with LPS for 2, 4, 8, 12 or 24 hr post-transfection.

FIGURE 4-9: Dominant negative mutant of MKK-4 inhibits LPS-induced B7-2 expression in THP-1 cells.

(A) THP-1 cells (1.0×10^6 /ml) were transfected with a pcDNA-3 plasmid expressing a dominant-negative (DN) mutant of MKK-4/SEK1 or a control pcDNA-3 plasmid and cells were cultured for 12 hr. After incubation the cells were stimulated with LPS ($1 \mu\text{g/ml}$) for 15 min. Total cell proteins were analyzed for phosphorylation of JNK MAPK using anti-phospho-JNK Ab. To control for protein loading, the membranes were stripped and reprobed with anti-JNK Abs.

(B) THP-1 cells (1.5×10^6 /ml) were transfected with a pcDNA-3 plasmid expressing a dominant-negative (DN) mutant of MKK-4/SEK1 or a control pcDNA-3 plasmid and cells were cultured for 12 hr. Following incubation, cells were stimulated with $1 \mu\text{g/ml}$ of LPS for another 24 hr followed by analysis of B7-2 expression by flow cytometry.

A

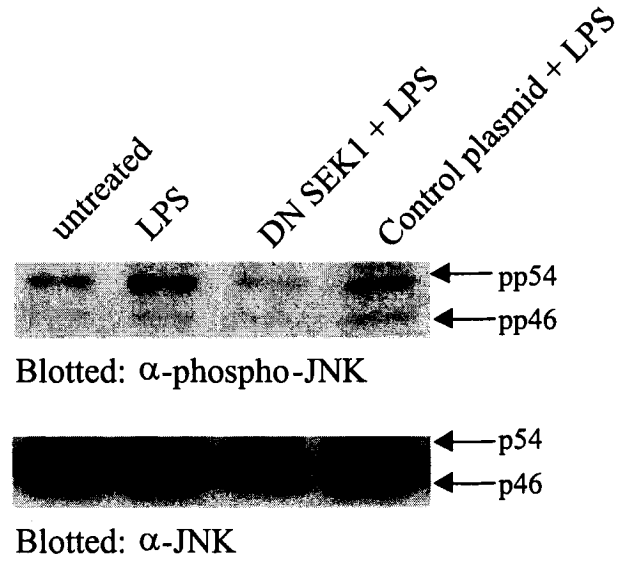

B

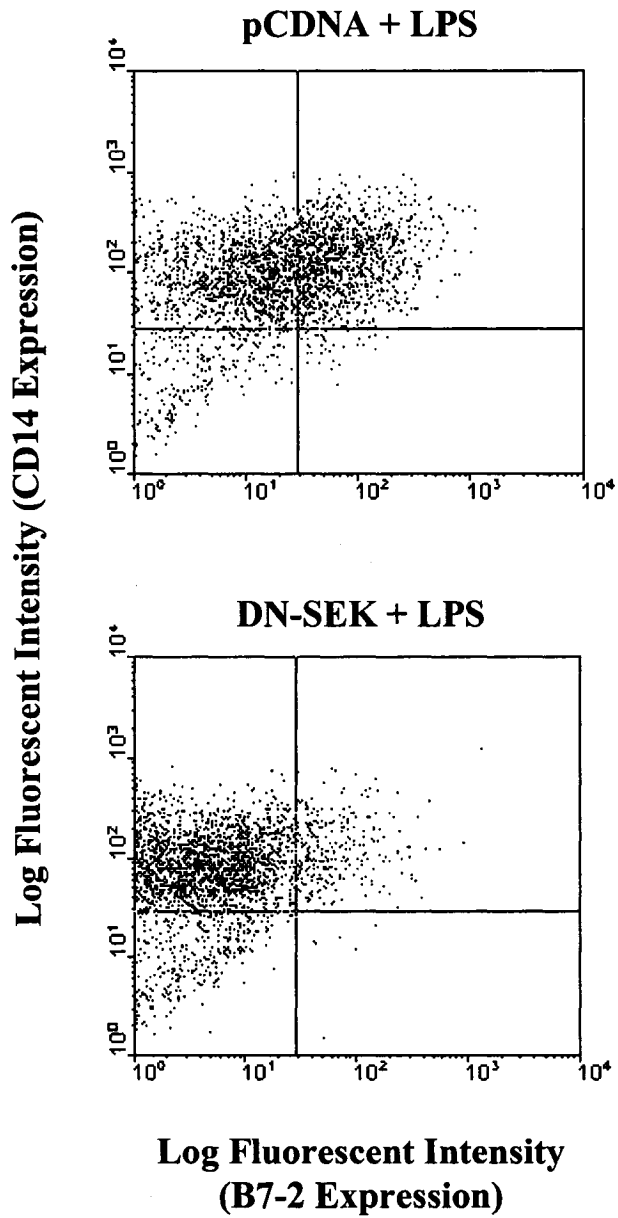

NFκB binding to the B7-2 promoter in LPS-stimulated cells is not regulated by dexamethasone

I investigated the signaling events downstream of JNK MAP kinases which might be involved in B7-2 transcription. B7-2 expression has been shown to be regulated via NFκB in normal human B cells in response to the signals delivered by T suppressor cells (170). Therefore, I investigated whether LPS stimulation of THP-1 cells induced the binding of NFκB to the NFκB binding site in the B7-2 promoter and whether this binding could be inhibited by dexamethasone. Cells were stimulated with LPS over a period of time ranging from 0 to 240 min and the nuclear extracts were analyzed for binding to NFκB oligonucleotide probe by a gel shift assay. The results revealed that the maximum binding of NFκB to the NFκB oligonucleotide sequence derived from the B7-2 promoter occurred 45 to 120 min following stimulation with LPS (Fig. 4-10A). I observed three distinct NFκB DNA-protein complexes that were blocked by competition with cold NFκB oligonucleotides, indicating their specificities. Incubation of THP-1 cells with dexamethasone for two hr prior to stimulation with LPS did not inhibit NFκB binding to the oligonucleotide containing the NFκB sequence (Fig. 4-10A).

Dexamethasone has been shown to inhibit the activation of AP-1 (195,196). Therefore, as a positive control, the same nuclear extracts were analyzed for AP-1 activity to determine the capacity of dexamethasone to inhibit LPS-induced AP-1 binding to the oligonucleotide probe. LPS stimulation induced the binding of AP-1 to the AP-1 oligonucleotide sequence in the B7-2 promoter and as expected, dexamethasone inhibited

FIGURE 4-10: Effect of dexamethasone on LPS-induced activation of NFκB (A) and AP-1 (B) transcription factors in THP-1 cells.

THP-1 cells were stimulated with LPS (1 μg/ml) for various times ranging from 15 to 180 min followed by centrifugation and collection of cell pellets. To determine the effects of dexamethasone on LPS-induced activation of NFκB and AP-1 transcription factors, were treated with dexamethasone (100 nM) for 2 hr prior to stimulation with LPS (1 μg/ml). To perform the gel shift assay, nuclear extracts were harvested from the cell pellets obtained at each time point. Nuclear extracts containing 5 μg of proteins were incubated for 1 hr with ³²P-labeled oligonucleotides corresponding to the consensus sequence for NFκB and AP-1. To determine the specificity of NFκB and AP-1 transcription factor binding, the nuclear extracts were incubated with either unlabeled oligonucleotides (100 fold) corresponding to the consensus sequence for NFκB or AP-1. The complexes were subjected to electrophoresis followed by autoradiography. Distinct NFκB and AP-1 DNA-protein complex bands were completely blocked by competition with cold NFκB and AP-1 oligonucleotides respectively indicating their specificities.

A

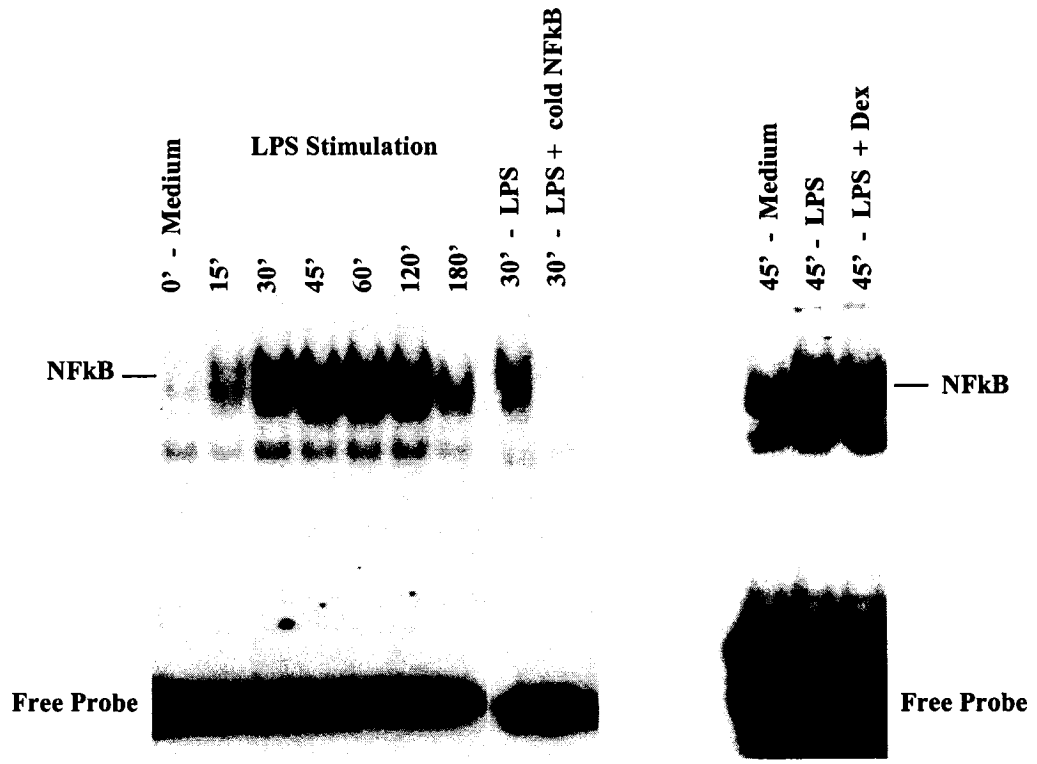

B

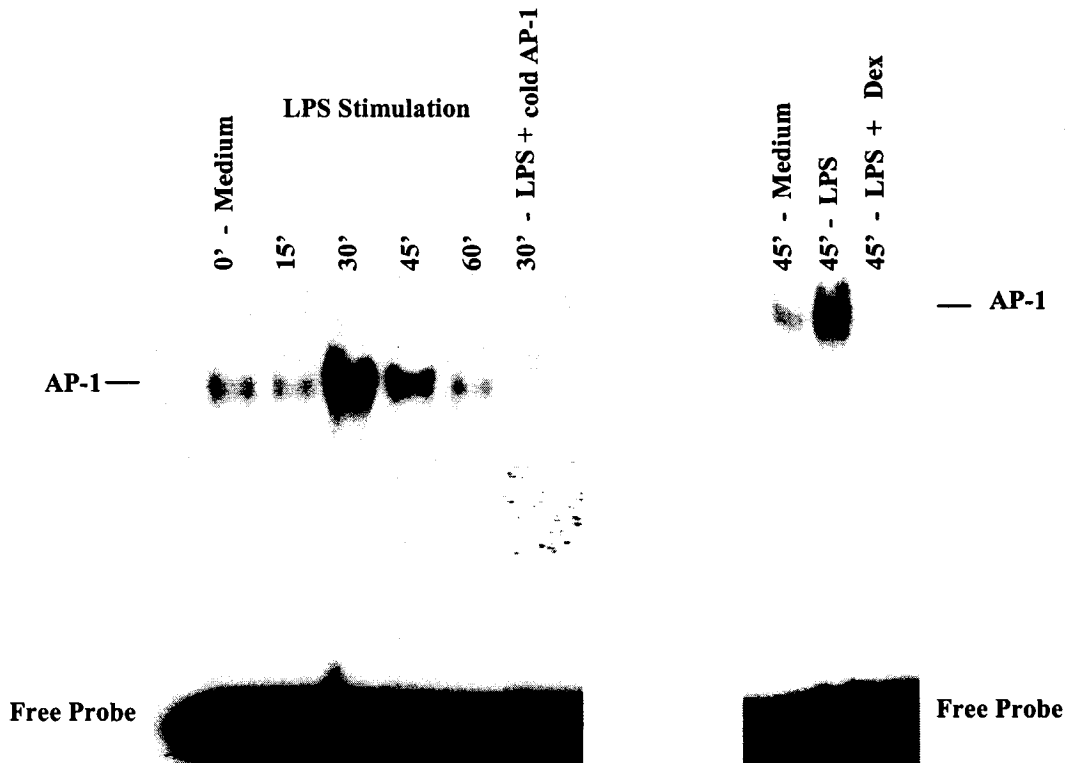

this interaction (Fig. 4-10B). These results suggest that the regulation of B7-2 expression by JNK may not involve NFκB in monocytic cells.

Role of NFκB and IRF-2 binding site within the B7-2 promoter in B7-2 transcription

Keeping in view, my initial results showing that NFκB induction is not involved in LPS-induced regulation of B7-2 expression, I initiated studies to define the transcription factors and the transcription factor binding sites on the human B7-2 promoter. Further characterization of the B7-2 promoter using the MatsInspector Professional software identified other potential transcription binding sites such as CREB and IRF-2 (Fig. 1-7). To assess the role of these transcription factors, B7-2 promoter was cloned into a pGL3B vector expressing a luciferase reporter gene.

To determine the requirements for maximal luciferase activity, optimization experiments were initially performed (Fig. 4-11). THP-1 cells were transfected with a pGL3 Control plasmid DNA by the DEAE-dextran method, followed by luciferase and β-galactosidase activity assays. The optimization experiments demonstrated that maximal luciferase activity was achieved when 15×10^6 THP-1 cells were transfected with 2.5 μg of pGL3 Control plasmid and 800 μg/ml of DEAE-dextran, following incubation for 30 min (Fig. 4-11). Subsequently, these conditions were used for all of the B7-2 promoter activity experiments.

To examine the effects of LPS on B7-2 promoter activity, and to identify the regions of the B7-2 promoter responsive to the LPS, B7-2 promoter constructs fused to a luciferase reporter were generated and transiently transfected into THP-1 cells. To assay

FIGURE 4-11: Optimization experiments for the DEAE-Dextran transfection of pGL3Control plasmid DNA into THP-1 cells.

Various concentrations of THP-1 cells were transiently cotransfected with different amounts of pGL3 Control vector and with 2.5 μ g of pSV- β -galactosidase control plasmid using the DEAE-dextran method. Cells were incubated with a range of DEAE-dextran and for various lengths of time. Luciferase activity was normalized for β -galactosidase activity to give relative luciferase units (RLU).

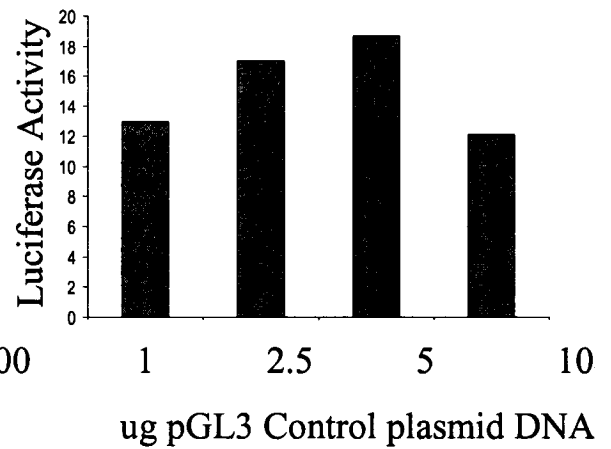
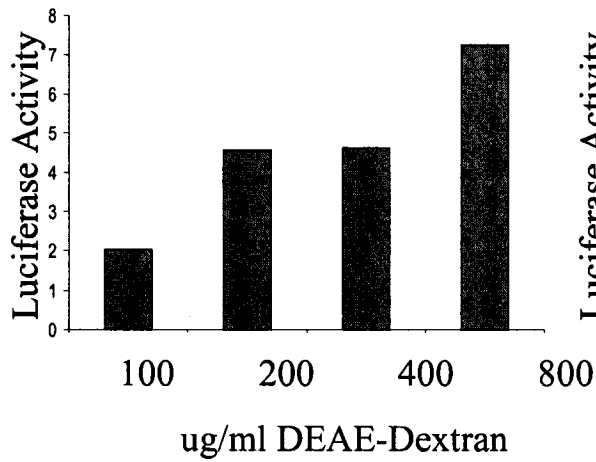
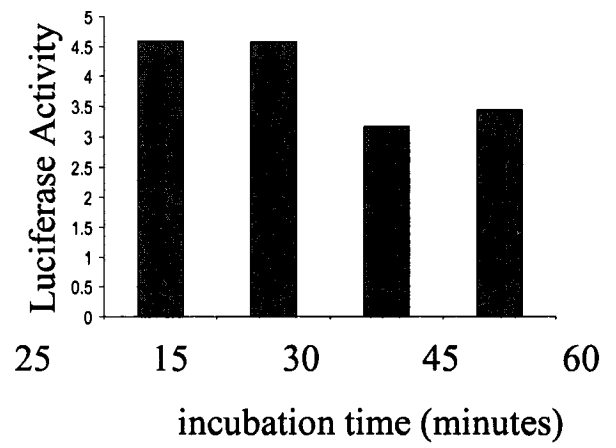
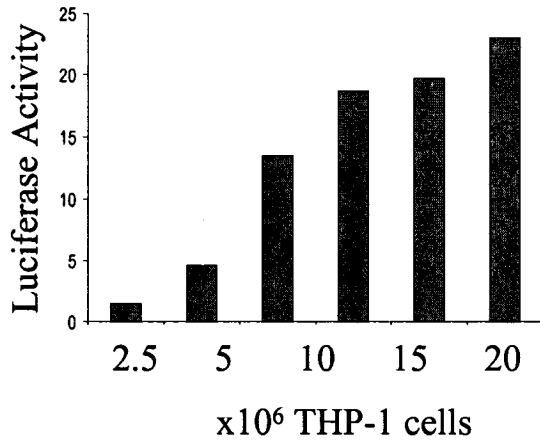

for promoter activity, luciferase activity was measured in transfected cells after stimulation with LPS. Deletion analysis were performed to map the transcription control regions of the B7-2 gene. Specific forward and reverse primers containing restriction enzyme sites were designed to isolate the B7-2 promoters by PCR (Table 2-2). The genomic DNA isolated from human peripheral blood mononuclear cells, was used to amplify the B7-2 promoter. PCR fragments were cloned into a PCRII TOPO subcloning vector and then subcloned into the pGL3B luciferase reporter gene plasmid. All of the B7-2 promoter/pGL3B luciferase reporter constructs thus generated were verified to by DNA sequence analysis.

THP-1 cells transfected with a full-length B7-2 promoter-luciferase reporter construct resulted in enhanced promoter activity over the promoterless pGL3B control vector upon stimulation with LPS for 24 h. (Fig. 4-12). To map the transcription factor binding sequences required for B7-2 transcription, a series of B7-2 promoter fragments (from 5' -622 to 3' +63 bp) were generated by successive deletions starting from the 5'-end. The location of consensus DNA binding sequences for various transcription factors identified within the B7-2 promoter are shown in Figs. 1-7 and 4-13. The results of the B7-2 deletion promoter experiments revealed maximal B7-2 promoter activities upon LPS stimulation with plasmids containing the promoter sequences from -622 and -133 bp relative to the transcription start site (Fig. 4-13). Deletion of sequences from -133 to -114 resulted in a significant three fold reduction in B7-2 promoter activity (Fig. 4-13). Using MatInspector Professional, no relevant transcription factor binding sites were found between the promoter sequences from -133 to -114. The MatInspector Professional software did reveal a CREB sequence which spanned from -150 to -130 of

FIGURE 4-12: LPS-stimulation induces luciferase activity in THP-1 cells transfected with a B7-2 promoter/luciferase reporter gene construct.

THP-1 cells (15×10^6 cells/ml) were transiently cotransfected with 2.5 μ g of either B7-2 promoter/luciferase reporter gene construct or pGL3E vector control and with 2.5 μ g of pSV- β -galactosidase control plasmid. Cells were incubated for 24 h followed by treatment with 1 μ g/ml of LPS for various times. Luciferase activity was normalized for β -galactosidase activity to give relative luciferase units (RLU). The results shown are a mean \pm S.D. of three independent experiments performed in triplicate.

B7-2(-1247/+63)/pGL3B Promoter Activity

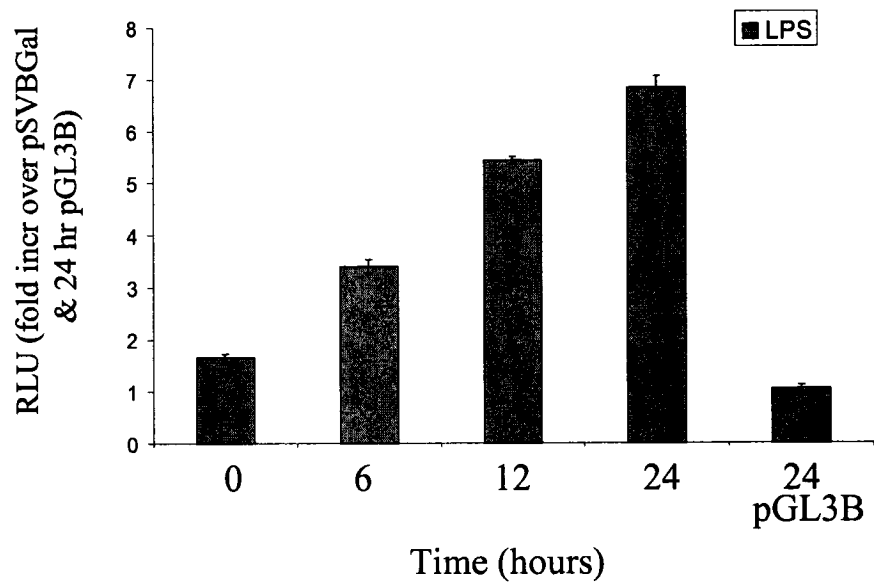
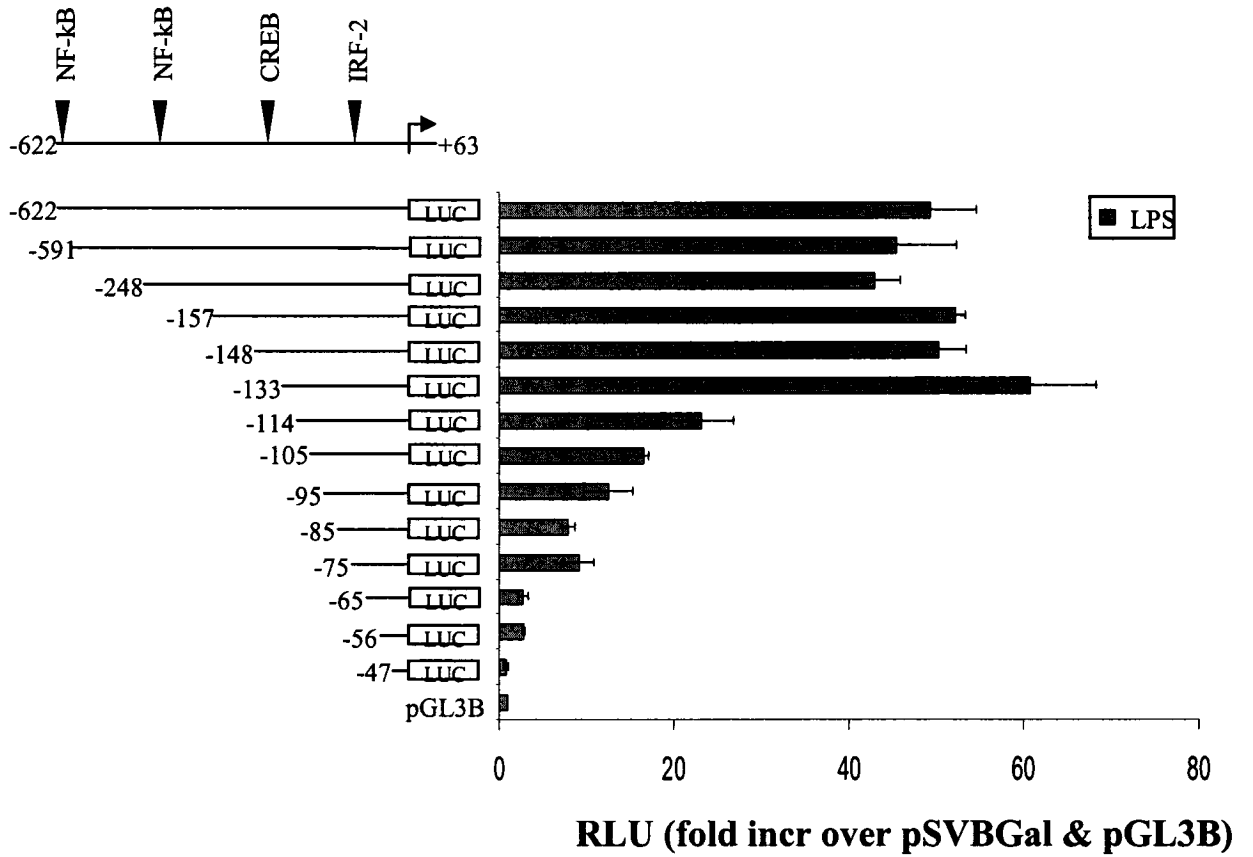
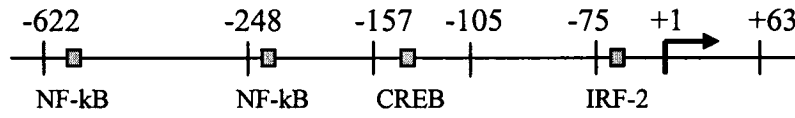

FIGURE 4-13: Transcriptional activities of B7-2 promoter in LPS-stimulated THP-1 cells.

The positions of the potential regulatory elements in the B7-2 promoter region (-622 to +63 bp relative to the start site). The line diagram represents the extent of deletions within the B7-2 promoter region. THP-1 cells were cotransfected with 2.5 μ g of either promoter deletion construct or vector control and with 2.5 μ g of β -galactosidase control plasmid. After 30 min of incubation, cells were stimulated with LPS (1 μ g/ml) for 24 h. Cell lysates from LPS-stimulated cells were assayed for luciferase and β -galactosidase activities. Luciferase activity was normalized for β -galactosidase activity to give relative luciferase units (RLU). The results shown are a mean \pm S.D. of six experiments performed in triplicate.



the B7-2 promoter. It appears that the CREB binding element may partially overlap the –133 to –114 region. Subsequent deletions of the B7-2 promoter sequences from the –114 to –47 regions in increments of 9 to 10 bases, decreased luciferase activity in a stepwise manner. Interestingly, I observed a complete loss in luciferase activity when the B7-2 promoter sequence was deleted from –75 to –65. Using MatInspector Professional to identify potential transcription binding sites, I was able to identify an IRF-2 sequence which encompassed the –73 to –61 region of the B7-2 promoter (Fig. 4-13).

To examine the role of NF- κ B, CREB, and IRF-2, I generated mutations on their binding sites by site-directed mutagenesis and cloned the fragments into the pGL3B vector. The wild-type sequences and the corresponding mutations are depicted in Figure 4-14. I wanted to determine the role of the two NF- κ B binding sequences because of the earlier findings by Li et al. on the involvement of the NF- κ B site (-614) in Th-induced transcription of B7-2. Cells transfected with the mutant plasmids containing the NF- κ B (-614) or NF- κ B (-240) mutations partially reduced luciferase activity. A more pronounced reduction was observed when the cells were transfected with a mutant plasmid containing a double mutation on both –614 and –240 NF- κ B binding sites. It appears that both NF- κ B binding sequences may act cooperatively to ensure maximal B7-2 promoter activity.

There appears to be a positive regulatory region between –133 and –114 of the B7-2 promoter, and CREB may play a role as it was the only transcription factor binding site found within this region. I generated two plasmids containing mutations on the CREB binding site and both mutations had similar luciferase activities when compared with cells transfected with a plasmid containing the wild type CREB binding sequence

(Fig. 4-14). This suggest that CREB does not play a role in the regulation of B7-2 promoter activity. As well, the positive regulatory region between -133 and -114 remains unidentified. The B7-2 promoter sequence between -73 and -61 contains an IRF-2 binding element, which may play a role in the regulation of LPS-induced B7-2 transcription. B7-2 promoter activity was abrogated when the cells were transfected with plasmids containing the IRF-2 mutation as compared with the plasmid containing the wild type IRF-2 sequence (Fig. 4-14). From the results of the B7-2 deletion and mutant promoter studies, the two NF κ B binding regions appear to play a cooperative role in maximizing B7-2 promoter activity. Also, there may be two additional positive regulatory regions on the B7-2 promoter, where one consist of an IRF-2 binding element and the other remaining undetermined. Further studies are in progress to further dissect the involvement of IRF-2 in B7-2 regulation of human monocytic cells.

FIGURE 4-14: The effect of mutating the NF- κ B, CREB, or IRF-2 regions on B7-2 promoter activity in LPS-stimulated THP-1 cells.

A site-directed mutation of the B7-2 sequences within the B7-2 promoter is shown in with respect to the wild type sequence. The substituted nucleotides at positions are underlined. THP-1 cells were cotransfected with either 2.5 μ g of wild type or mutant B7-2 constructs and with 2.5 μ g of β -galactosidase control vector followed by LPS stimulation and measurement of luciferase activities (RLU). Results shown are a mean \pm S.D. of three independent experiments performed in triplicate.

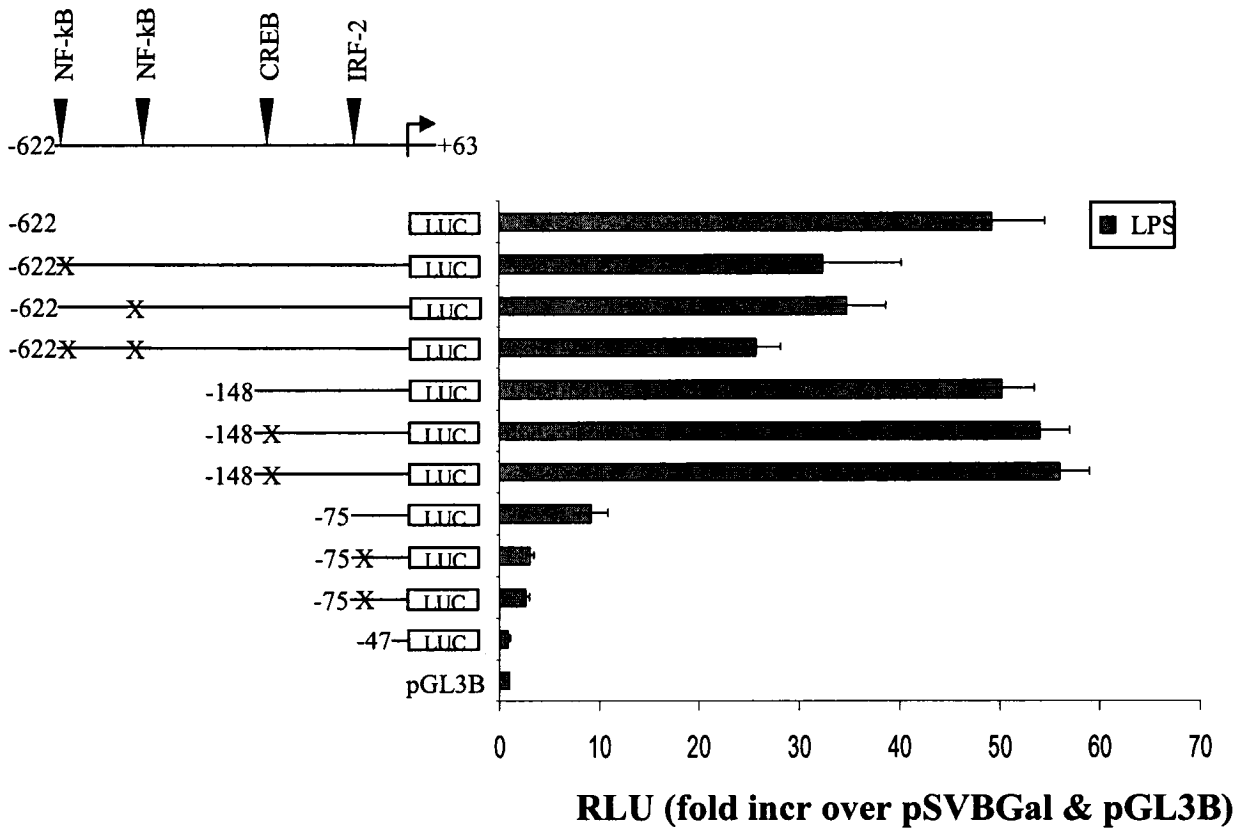
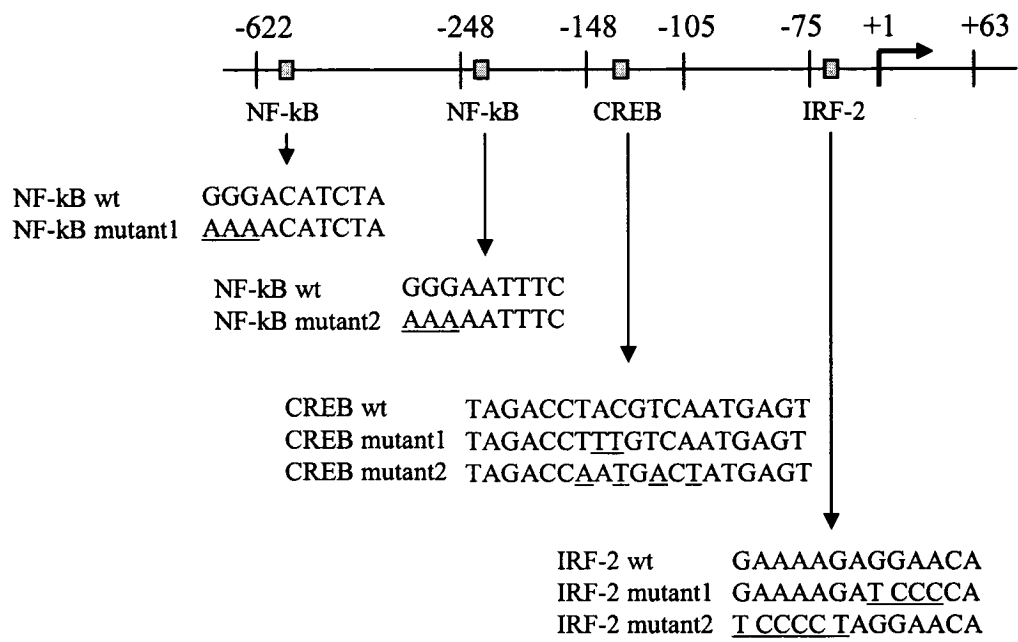

CHAPTER 5:
DISCUSSION

Bacterial endotoxin or LPS is responsible for many of the cellular responses to Gram-negative bacterial infections. These responses may be induced after the association of LPS with the plasma LPS-binding protein (197) and the binding of this complex with the CD14/TOLL receptor (TLR-4) complex (111,198). LPS stimulation of monocytic cells modulates the expression of costimulatory molecules including B7-1 and B7-2 (9,40,52,182,199) that plays a vital role in immune activation and development of T helper responses (9,40,52,182,199). Modulation of B7 expression on APCs may thus alter the development of immune responses. Since B7 play a critical role in T cell activation and differentiation (180), immunoregulatory cytokines and mitogens such as LPS that enhance B7-1 and B7-2 expression provide a mechanism for the amplification of T cell activation, and development of cellular immune responses and autoimmune disorders. Therefore, understanding B7 regulation and characterizing the signal transduction events involved may lead to the development of strategies for the treatment of inflammation, autoimmune diseases, and cancer.

The molecular mechanism, in particular, the signaling molecules and the transcription factors involved in the regulation of B7-1 and B7-2 expression is poorly understood. For my Ph.D. research project, I have examined the role of MAPKs and the transcription factors involved in LPS-induced expression of B7-1 and B7-2 in human monocytes and the promyelomonocytic THP-1 cells as a model system. The results obtained for the regulation of B7-1 and B7-2 expression in human monocytic cells are discussed in two separate sections as below:

Regulation of B7-1 expression in human monocytic cells:

My results suggest that JNK MAPK plays a critical role in the regulation of LPS-induced B7-1 expression in human monocytic cells. I have also investigated the role of PI-3K and calcium signaling as LPS is known to trigger these pathways in human monocytic cells (200-202). My results suggest that neither the PI-3K nor the calcium signaling pathway were found to be involved in the regulation of B7-1 and B7-2 expression by LPS in human monocytic cells (data not shown). In addition, I have identified for the first time, a distinct B7-1 responsive element corresponding to the IRF-7 binding sequence located between -84 to -72 bp upstream of the transcription start site of the B7-1 gene. Furthermore, LPS-induced B7-1 expression in monocytic cells may be regulated by the IRF-7 transcription factor through the activation of JNK MAPKs (203).

Very little is known regarding the signaling pathways and transcription factors involved in the regulation of B7-1 expression. In this study, I analyzed a B7-1 promoter element in order to identify the transcription factor binding sequences responsible for B7-1 gene transcription. I consistently observed a basal constitutive luciferase activity in cells transfected with the plasmid containing the B7-1 promoter linked to the luciferase reporter gene (pB7.1Pr.GL3E). The B7-1 promoter activity was inducible as LPS stimulation of cells transfected with pB7.1Pr.GL3E resulted in approximately three fold increased luciferase activity compared to the unstimulated cells. I identified a DNA sequence located between -84 to -72 bp upstream of the transcription start site and computer aided analysis revealed that this binding element has similarities with the IRF-7-binding sequence. Mutation of the IRF-7 sequence in the B7-1 promoter construct abrogated the luciferase activity suggesting the involvement of the IRF-7 in the

regulation of B7-1 gene transcription in LPS-stimulated monocytic cells. Fong et al identified a B7 regulatory element (RE) (-60 to -47 bp upstream of the transcription start site) responsible for B7-1 gene transcription in Epstein Barr Virus (EBV)-transformed Raji B cells (161). This B7-RE activity was not inducible following stimulation and was not characterized. However, in my studies, transfection of THP-1/CD14 cells with the promoter construct containing sequences -72 bp upstream of transcription start site containing B7-RE consistently failed to elicit luciferase activity in either unstimulated or LPS-stimulated cells. This discrepancy may be attributed to the use of B cells compared to the monocytic cells used in our study. B7-1 expression has also been shown to be regulated in B cells by the NF κ B binding site located in the enhancer region approximately 3 kb upstream of the B7-1 transcription start site (160). Although I analyzed the promoter region encompassing the sequences up to -587 bp relative to the transcription start site, the involvement of other transcription factors particularly NF κ B with binding sites located in the upstream enhancer region can not be ruled out. IRF-7 has been shown to cooperate physically and functionally with coactivator proteins including NF κ B, and CBP/p300 (203,204). These interactions not only stimulate the intrinsic IRF-7 transcriptional activity, but they are also indispensable for its ability to strongly synergize with other transcription factors, including c-Jun and IRF-3 (203-206). Whether IRF-7 mediates LPS-induced B7-1 expression by directly binding to the B7-1 promoter or through cooperative action with NF κ B needs to be understood.

The involvement of IRF-7 was further confirmed by competition studies in gel shift assays with cold oligonucleotides corresponding to the consensus IRF-7 sequence represented by the PRD-1 oligonucleotides. The PRD-1 oligonucleotide sequences

specifically bind IRF-7 transcription factor. The results that cold B7-1 oligonucleotides corresponding to the IRF-7 sequences inhibited the band detected following incubation of nuclear extracts with PRD-1 probe further suggested the involvement of IRF-7 in LPS-induced B7-1 transcription. However, I could not detect high molecular weight complexes in my super-shift experiments with anti-IRF-7 antibodies. This may be attributed, in part, to the unavailability of good commercially available anti-IRF-7 antibodies. Additionally, unidentified proteins present in the complexes formed following incubation of nuclear extracts with the oligonucleotide probes may have prevented the detection and formation of high molecular weight complexes in supershift experiments. This was evident by the presence of non-specific bands that could not be competed out with cold B7-1 oligonucleotides even when used at 400 fold higher concentrations relative to the labeled probe.

IRFs are a family of transcription factors comprising of nine members with multiple functions including apoptosis, oncogenesis, host defence, viral latency and immune responses (204,206). The hallmark of this family of transcription factors is its N-terminal DNA-binding domain, which has well spaced conserved five tryptophan repeat sequences to form a helix-turn-helix motif that latches onto DNA (204,207). The C-terminal region of the IRFs is variable and defines multiple biological functions (207). IRF-7, cloned and identified within the biological context of Epstein-Barr virus (EBV) latency, plays a critical role in the activation of IFN genes during viral infections to evoke anti-viral responses, and in the pathogenesis of some EBV-associated tumors (206,208,209). A number of agents including LPS, viral infections such as Sendai and EBV can induce the expression and activation of IRF-7 (206,209). Although IRF-7 is a

weak phosphoprotein normally expressed in cytoplasm, augmentation of its phosphorylation by LPS/EBV-LMP-1 may facilitate localization of IRF-7 from the cytoplasm to the nucleus (207,209,210).

The mechanism by which IRF-7 is activated and cooperates with other transcription factors is not fully elucidated, although an unknown virus activated kinase has been suggested to phosphorylate IRF-7 (211). Very little is known about the signaling pathways involved in the regulation of B7 expression in general and particularly in response to stimulation of monocytic cells with its most potent mitogen LPS. Very recently, PI-3K was suggested to upregulate B7 expression in EBV transformed human B cells following ligation with CD40/CD40 homodimers (212). In this study, I investigated the involvement of MAPKs in an attempt to elucidate the upstream signaling pathways involved in the activation of IRF-7 and induction of B7-1 in LPS-stimulated monocytic cells. My results clearly suggest that LPS-induced B7-1 expression involved the activation of JNK, but not of p38 or ERK MAPKs in human monocytic cells. This conclusion was based on results from experiments using the JNK-specific inhibitor SP600125 and other agents such as DXM and curcumin which are known to inhibit the activation of JNK MAPKs (174). Studies designed to understand the signalling events downstream of JNK MAPKs activation responsible for B7-1 gene transcription suggested that LPS-induced B7-1 expression may be regulated by IRF-7 through JNK activation. The IRF-7 activity as determined by luciferase and gel shift assays was completely inhibited by SP600125.

The JNK MAP kinase pathway includes JNK1, JNK2 and JNK3 (120). JNK1 and JNK2 are widely expressed in several tissues, whereas JNK3 is more selectively

expressed in brain, testis, and heart. JNK3 gene has been shown to be involved in neuronal cell death (213), whereas JNK1 and JNK2 have been implicated in Th1/Th2 cell differentiation (214,215). JNK1 has also been shown to regulate the development of T cell-mediated immunity against *Leishmania major* infections in an experimental mouse model (216).

My results clearly suggested that LPS-induced regulation of B7-1 expression is selectively regulated by the JNK MAPKs in human monocytic cells. The involvement of JNK MAPKs in B7-1 regulation was demonstrated by employing a number of pharmacological JNK inhibitors including SP600125, dexamethasone and curcumin. My results also suggested that neither PI3 kinase nor the calcium signaling pathways were involved in the regulation of LPS-induced B7-1 expression. This was again demonstrated by employing pharmacological inhibitors specific for PI3 kinase (LY249002 and wortmanin), and calcium signaling pathway (EGTA, SKF, APB, KN-93, W7). I recognize that the major drawback of using pharmacological inhibitors is that when used at high concentrations, these agents tend to be toxic. However, I have always used low concentrations of these inhibitors and made sure that the effects observed are dose dependent. I have also examined the effects of all pharmacological inhibitors used in the present study on the viability of cells by staining apoptotic cells with propidium iodide. In addition, the viable cells observed by FACS analysis were gated for determination of apoptotic cells following treatment with the highest concentration of inhibitors. My results clearly demonstrated that none of these inhibitors at any concentration used caused apoptosis. Furthermore, I also confirmed the above results obtained by flow cytometry by employing another technique using RT-PCR analysis. This technique of

quantifying mRNA allows much shorter incubations with inhibitors and hence lessens their toxic effects. LPS induced B7-1 mRNA expression was inhibited by DXM and SP600125 in both monocytes and THP-1/CD14 cells, clearly suggesting a key role for JNK MAPKs in B7-1 regulation.

I also recognize that whenever possible, the results obtained with the pharmacological inhibitors should be verified by using dominant negative mutants or activators. In this study, I employed stealth siRNAs (Invitrogen) specific for JNK1 and JNK2 to determine if these agents can inhibit LPS-induced B7-1 expression in THP-1 cells. THP-1/CD14 cells were transfected with either stealth RNA for JNK1 or JNK2 for a period of 24 hr followed by LPS stimulation for an additional 16 hr. Since it is difficult to transfect a high proportion of the THP-1 cells and LPS being a powerful mitogen that can induce B7-1 expression as very low concentrations (50 pg/ml), I stimulated the cells with a lower concentration of LPS (100 ng/ml) and for a shorter period of time (12 hr) than in the previous experiments. My results show that both stealth RNA for both JNK1 and JNK2 significantly inhibited LPS-induced B7-1 expression. Incomplete abrogation of the LPS-induced B7-1 expression can be explained by the relatively low transfection efficiency of the stealth RNA.

Although interaction of LPS with its receptor complex CD14/TLR-4 results in the activation of several signaling cascades including MAPKs, PI3K and the calcium signaling pathways and a host of transcription factors, it is surprising to observe that LPS-induced expression of B7-1 primarily involved the activation of JNK MAPKs and the IRF-7 transcription factor alone. B7-1 can also be induced by several other stimuli such as IFN- γ on monocytic cells and CD40 stimulation on B cells (25,37,217). However,

it remains to be determined if IFN- γ - or CD40-induced B7-1 expression involves the activation of JNK MAPK and/or IRF-7 transcription factor. IRFs are known to be activated by IFN family of cytokines especially IFN- α and IFN- β (207,218). It is also known that LPS stimulation of monocytic cells results in the induction of both IFN- α as well as IFN- β (219,220). Therefore, it was interesting to determine if LPS-mediated effects on B7-1 induction were being mediated by the endogenously produced IFN- α and/or IFN- β . Therefore, I investigated the effects of IFN- α and IFN- β on the induction of B7-1 in THP-1 cells. In the event LPS-induced B7-1 expression is dependent on endogenously produced IFN- α or IFN- β , then recombinant IFN- α or IFN- β should be able to induce B7-1 expression on these cells. My results showed that neither IFN- α nor IFN- β induced B7-1 expression (data not shown) suggesting that LPS-induced B7-1 expression is independent of endogenously produced IFN- α or IFN- β .

JNK MAPK has been suggested to play a key role in the regulation of immune responses such as CD4⁺ Th cell differentiation, production of macrophage derived Th cytokines including IL-12 (221,222), and in several autoimmune diseases including type I diabetes (223). Since B7 induction has also been suggested to play a key role in many such processes (50,52,183,184), it will be interesting to determine the overall involvement of JNK MAPK and IRF-7 in B7-1 induction and B7-1-mediated effects by employing JNK or IRF-7 null mice, respectively. In the event, JNK knock out mice are able to effectively block B7-1 induction in response to certain stimuli such as LPS, and reduced severity of some autoimmune diseases in experimental animal models, JNK may represent an alternative pharmacological target for the design of a small molecule inhibitor that could modulate B7 induction, Th responses and therefore protect against

autoimmune diseases. In the laboratory group of Kumar et al., it was determined that JNK was involved in IL-12p40 production through the activation of AP-1 and NF- κ B transcription factors in LPS-stimulated human monocytic cells (221). This further illustrates the importance of JNK as IL-12 plays a critical role in the development of cell-mediated immune responses and in the pathogenesis of inflammatory and autoimmune disorders such as multiple sclerosis and experimental autoimmune encephalomyelitis (224-226). Because of the biological significance of JNK in a wide variety of diseases, many drug discovery companies have developed small-molecule inhibitors of JNK for the treatment of inflammatory and neurodegenerative diseases (227).

The JNK pathway is implicated in stress-induced apoptosis. Therefore, it is believed that blocking the activation of JNK using JNK inhibitors may promote cell survival. In fact, recent studies have demonstrated that administration of JNK inhibitors such as SP600125 and AS601245 protected rodents from brain, heart, and renal ischemia (228-231). JNK may also play a role in the treatment of diabetes. Diabetes is a chronic disease characterized by decreased insulin production in pancreatic β cells or insulin resistance by insulin-target cells. Using cell-permeable JNK-inhibitory peptides it was shown to prevent apoptosis of islet cells during pancreatic islet transplantation (232). As well, intraperitoneal administration of JNK-inhibitory peptides have demonstrated improved insulin resistance in a diabetic mice model (233). All this demonstrates the therapeutic potential of JNK in treating inflammatory and autoimmune diseases.

In summary, to my knowledge, this is the first report demonstrating the involvement of the IRF-7 transcription factor in the regulation of B7-1 gene transcription. My results also suggest that JNK MAPK may play a critical role in IRF-7 activation and

eventually the regulation of B7-1 expression in human monocytic cells in response to stimulation with LPS. A model for the regulation of B7-1 is presented in Fig. 5-1. IRF-7, a potent inducer of IFN- γ genes, appears to function in concert with other transcription factors such as IRF-3, p300/CBP, and c-jun. Identification of factors that bind to IRF-7 in the context of B7-1 induction will facilitate further understanding the regulation of this important costimulatory molecule.

FIGURE 5-1: Model of the regulation of B7-1 costimulatory molecule by LPS in human monocytic cells.

Normal human monocytic cells do not express B7-1 ligands but respond upon stimulation with LPS. LPS-induced B7-1 transcription in human monocytic cells may be regulated by IRF-7 transcription factor through JNK MAPKs activation.

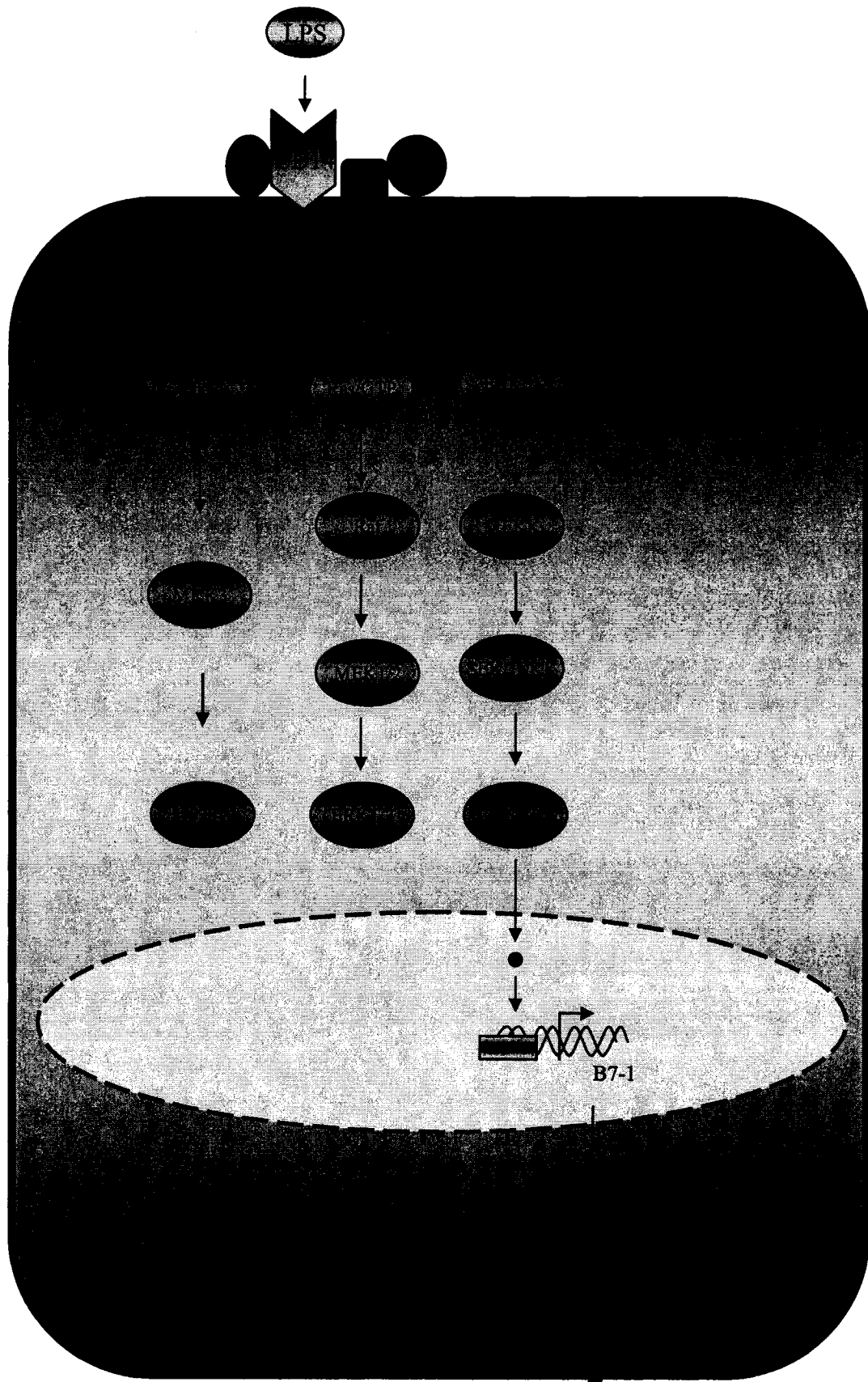

B7-1

Monocyte

Regulation of B7-2 expression in human monocytic cells:

The molecular mechanism by which B7-2 expression is regulated is also not well understood. Studies designed to understand the regulation of B7-2 expression in human monocytic cells revealed an IL-10-dependent and IL-10-independent regulation of B7-2 in LPS-stimulated human monocytic cells. My results suggest that the LPS stimulation of normal human monocytes results in the down-regulation of B7-2 that may be mediated via endogenously-produced IL-10 involving p38 MAP kinase. On the other hand, THP-1 cells that are refractory to the inhibitory effects of IL-10, and hence show IL-10-independent effects on B7-2 expression, exhibited enhanced B7-2 expression upon LPS stimulation. Studies of the molecular mechanisms involving cell signaling molecules reveal that JNK MAP kinases may mediate IL-10-independent regulation of B7-2 expression in LPS-stimulated THP-1 cells. Taken together, my results reveal the involvement of two distinct MAP kinases, p38 and JNK, in IL-10-dependent and IL-10-independent regulation of B7-2 expression, respectively, in LPS-stimulated monocytic cells. I also investigated the transcription factors involved in the regulation of B7-2 expression in human monocytic cells. My results suggest that B7-2 transcription is complex and is regulated by multiple transcription factors. Deletion and mutational promoter analysis pointed to the involvement of NF κ B, IRF-2, and an unidentified region in the regulation of B7-2 expression. It appears that these three regions may act cooperatively to regulate maximal B7-2 promoter activity in human monocytic cells.

The biological effects attributed to LPS may represent the combination of signals delivered following the interactions of LPS with CD14/TLR-4, and of endogenously-produced cytokines with their cognate receptors. One such endogenously-produced

immunoregulatory cytokine, IL-10, is known to inhibit B7-2 expression on normal human monocytic cells (25,37). My results show that IL-10 may play a key role in LPS-mediated down-regulation of B7-2 expression in human monocytes. This conclusion was derived by using neutralizing anti-IL-10 antibodies which ablated LPS-mediated B7-2 down-regulation. In addition, the p38 MAP kinase inhibitor SB202190 inhibited LPS-stimulated IL-10 production in monocytes (174,175) and prevented LPS-induced B7-2 down-regulation (Fig. 4-2).

I have previously shown that amongst the cytokines produced by activated monocytes, TNF- α and IL-10 down-regulate B7-2 expression (91). TNF- α has also been shown to induce IL-10 expression in monocytes (134,234,235). The inhibitory effect of TNF- α on B7-2 expression may thus be due to endogenously-produced IL-10. This is supported by the observations that TNF- α did not effect B7-2 expression on IL-10 refractory THP-1 cells (data not shown). Furthermore, although LPS stimulation induces the production of both IL-10 and TNF- α , neutralizing anti-IL-10 antibodies were able to prevent B7-2 down-regulation.

I investigated the role of MAP kinases in an attempt to understand the signaling pathways governing LPS-mediated B7-2 regulation. MAP kinase signaling pathways are strictly regulated during the development and differentiation of T cells (214,215,222,236,237) and play a key role in a variety of cellular responses. LPS activates all three MAP kinase pathways either individually or simultaneously, thereby suggesting their independent signaling roles (116,125,186,187). My results show that in contrast to p42/44 ERKs, p38 MAP kinase was involved in LPS-stimulated IL-10-dependent B7-2 down-regulation. B7-2 down-regulation was reversed by blocking the

endogenous IL-10 production with the p38 MAP kinase inhibitor, SB202190, which has been shown to inhibit LPS-induced IL-10 production in monocytic cells (Fig. 4-2C) (127,174). I further show that exogenous addition of IL-10 to LPS-stimulated monocytes in which endogenous IL-10 production was blocked by SB202190 treatment reversed the SB202190-induced reconstitution of B7-2 expression (Fig. 4-4 and Table 4-1).

The molecular mechanism by which IL-10 mediates its inhibitory effects is not well understood. IL-10 has been shown to mediate its inhibitory effects on proliferation in murine macrophages through the activation of Stat3. Recently, IL-10 has been shown to increase the expression of the cell cycle inhibitor, cyclin-dependent kinase inhibitor p19^{INK4D} in macrophages. IL-10-induced expression of p19^{INK4D} was later shown to be dependent on the activation of Stat3, indicating that Stat3-dependent activation of p19^{INK4D} constitute an important component of the mechanism by which IL-10 inhibits macrophage proliferation (146). In this study, I hypothesized that endogenously produced IL-10 following LPS stimulation may down regulate B7-2 expression through the activation of p38 or ERK MAP kinases. My results clearly show that IL-10 induced the activation of p42/44 ERK alone. However, neither p38 nor p42/44 ERK kinases were involved in the regulation of IL-10-induced B7-2 expression. Whether IL-10-induced regulation of B7-2 expression is also mediated by Stat3-dependent activation of cyclin-dependent kinase inhibitors p19^{INK4D} needs to be investigated.

In general, IL-10-mediated inhibitory effects on cell proliferation and synthesis of proinflammatory cytokines have been shown to be regulated through STAT-3 activation (13,14,16,17). IL-10 is also known to activate STAT-1 in monocytic cells (152). However, in contrast to STAT-3, the role of STAT-1 in regulating IL-10-mediated

biological effects is not well understood. Recently, we investigated the signaling pathways involved in the IL-10-induced stimulatory effect on CD14 expression, and in particular the role of IL-10-activated STAT-1 in human monocytic cells. We demonstrated for the first time that IL-10-induced CD14 expression is mediated by a mechanism involving STAT-1 activation independent of STAT-3 (152). Furthermore, IL-10-activated STAT-1 was found to be regulated through PI3K activation either alone or in concert with the ERK MAPKs. Whether IL-10-induced regulation of B7-2 expression is also mediated by STAT-1 through the activation of PI3 kinase either alone or in combination with ERK MAPK remains to be investigated.

IL-10-independent regulation of B7-2 expression could not be studied in normal human monocytes because of the inherent IL-10 production induced by LPS stimulation. To overcome this obstacle, I employed IL-10-refractory THP-1 cells in which LPS stimulation resulted in enhanced B7-2 expression. Studies of the role of MAP kinases in IL-10-independent regulation of B7-2 expression revealed the selective involvement of JNK. This conclusion was based on results derived from transfection of THP-1 cells with dominant-negative (DN) mutants of MKK-4/SEK1 kinase. Two MAPK kinases, MKK4 and MKK7, have been found to be the primary activators of JNK (129,238). MKK4 is an essential component of the JNK signal transduction pathway and disruption of the MKK4 gene blocks JNK activity (200). DN SEK1 has also been shown to act as a specific inhibitor of the JNK signal transduction pathway (192-194). However, it has been shown recently that MKK4 can also activate the p38 MAP kinase (129,131). Since p38 MAP kinase inhibitors did not influence B7-2 expression in THP-1 cells, abrogation of LPS-induced B7-2 expression following transfection of DN SEK1 makes p38 involvement

highly unlikely and suggests a key role for JNK kinase in the regulation of LPS-induced B7-2 expression.

The role of JNK MAP kinases in the regulation of B7-2 expression was initially studied by employing dexamethasone, a steroidal anti-inflammatory glucocorticoid. Glucocorticoids have been shown to inhibit IFN- γ -induced B7-1 expression in normal human monocytes (89). The molecular mechanism by which glucocorticoids mediate their biological effects have been investigated. Glucocorticoids inhibit cytokine production by complexing with AP-1 and thus down-regulating AP-1 activity (195,196). Furthermore, dexamethasone has been shown to inhibit AP-1 activity by interfering with JNK phosphorylation (188,191). In this study, I show for the first time that dexamethasone can reverse the LPS-induced, IL-10-independent regulation of B7-2 expression in both monocytes and THP-1 cells. These results point towards the involvement of JNK in LPS-mediated B7-2 regulation.

To understand the signaling events downstream of JNK MAP kinase activation responsible for B7-2 gene transcription, attempts were made to identify the transcription factors involved. The regulatory region for the B7-2 gene has been cloned recently (167). NF κ B has been suggested to regulate B7-2 expression in human B cells activated by the signals delivered by T suppressor cells (170). To this end, I examined whether NF κ B is activated in JNK-mediated B7-2 induction. Since dexamethasone did not inhibit LPS-induced NF κ B activation in THP-1 cells (Fig. 4-10), my results suggest that NF κ B activation is not involved in the JNK-mediated induction of B7-2 expression in monocytic cells. As my results also show inhibition of AP-1 activation by dexamethasone, it is likely that AP-1 may play a role in LPS-induced B7-2 regulation.

Further studies are needed to understand the role of transcription factors other than NF κ B in the downstream signaling events which follow JNK activation and which induce B7-2 expression.

The transcription factors involved in the regulation of B7-2 expression have not been well defined. To understand the role of transcription factors other than NF κ B in the downstream signaling events which follow JNK activation and which induce B7-2 expression, I analyzed the human B7-2 promoter. Using THP-1 cells transfected with a B7-2 promoter/luciferase reporter plasmid, a strong B7-2 promoter activity was observed upon LPS stimulation (Fig. 4-12). Deletion and mutational promoter analysis pointed to two potential positive regulatory regions, an IRF-2 region and an unidentified region (Fig. 4-13 and 4-14). IRF-1 and IRF-2 belong to the interferon regulatory factor family of transcription factors and were originally discovered as regulators of type I interferon and virus-inducible genes. IRF-1 acts as a transcriptional activator, whereas IRF-2 functions as a transcriptional repressor by inhibiting IFN and IRF-1 induced transcription. Recent studies have determined that IRF-2 can also act as a transcriptional activator for several genes, including vascular cell adhesion molecule-1, class II transactivator, IL-7, H4 histone, and gp91 (phox). Therefore, IRF-2 has both transcriptional activation and repression properties. Other studies have shown that IRF-1 and IRF-2 also function as regulators of cell growth, transformation and apoptosis. By mutating both NF κ B regions on the B7-2 promoter, there was a partial reduction in B7-2 promoter activity (Fig. 4-14). This suggested a partial involvement of NF κ B in regulating B7-2, and may explain why dexamethasone was unable to inhibit LPS-induced NF- κ B activation during the gel shift studies. My results suggest the involvement of NF κ B, IRF-2, and an unidentified region

in the regulation of B7-2 expression. It appears that these three regions may act cooperatively to regulate maximal B7-2 promoter activity in human monocytic cells. Further studies are in progress in the laboratory of Dr. Kumar to clearly identify the transcription factors involved in the regulation of B7-2 expression in human monocytic cells.

In summary, my results clearly point to a key role for endogenously-produced IL-10 in the down-regulation of B7-2 expression in LPS-stimulated human monocytes. This IL-10-dependent regulation of B7-2 expression involved the activation of p38 MAP kinase. In THP-1 cells that are refractory to the inhibitory effects of IL-10, LPS-induced B7-2 expression revealed an important role of JNK in previously unidentified IL-10-independent regulation of B7-2 expression. The differential regulation of B7-2 expression in THP-1 cells and monocytes reveals the cross-talk between the signals delivered by interactions of IL-10-IL-10R and LPS-CD14/TLR-4. Further characterization of the mechanism for regulation of IL-10 independent LPS-induced B7-2 expression will help in manipulation of immune responses. A model for the regulation of B7-2 expression in human monocytic cells is presented in Fig. 5-2.

FIGURE 5-2: Model of the regulation of B7-2 costimulatory molecule by LPS in human monocytic cells.

Normal human monocytic cells express B7-2 ligands which is down-regulated upon stimulation with LPS or IL-10. In my model, I see the distinct involvement of p38 in IL-10 dependent, and JNK in IL-10-independent regulation of B7-2 expression in LPS-stimulated monocytic cells. As well, NF κ B, an unknown binding element, and IRF-2 on the B7-2 promoter may act cooperatively to regulate maximal B7-2 transcriptional activity in human monocytic cells.

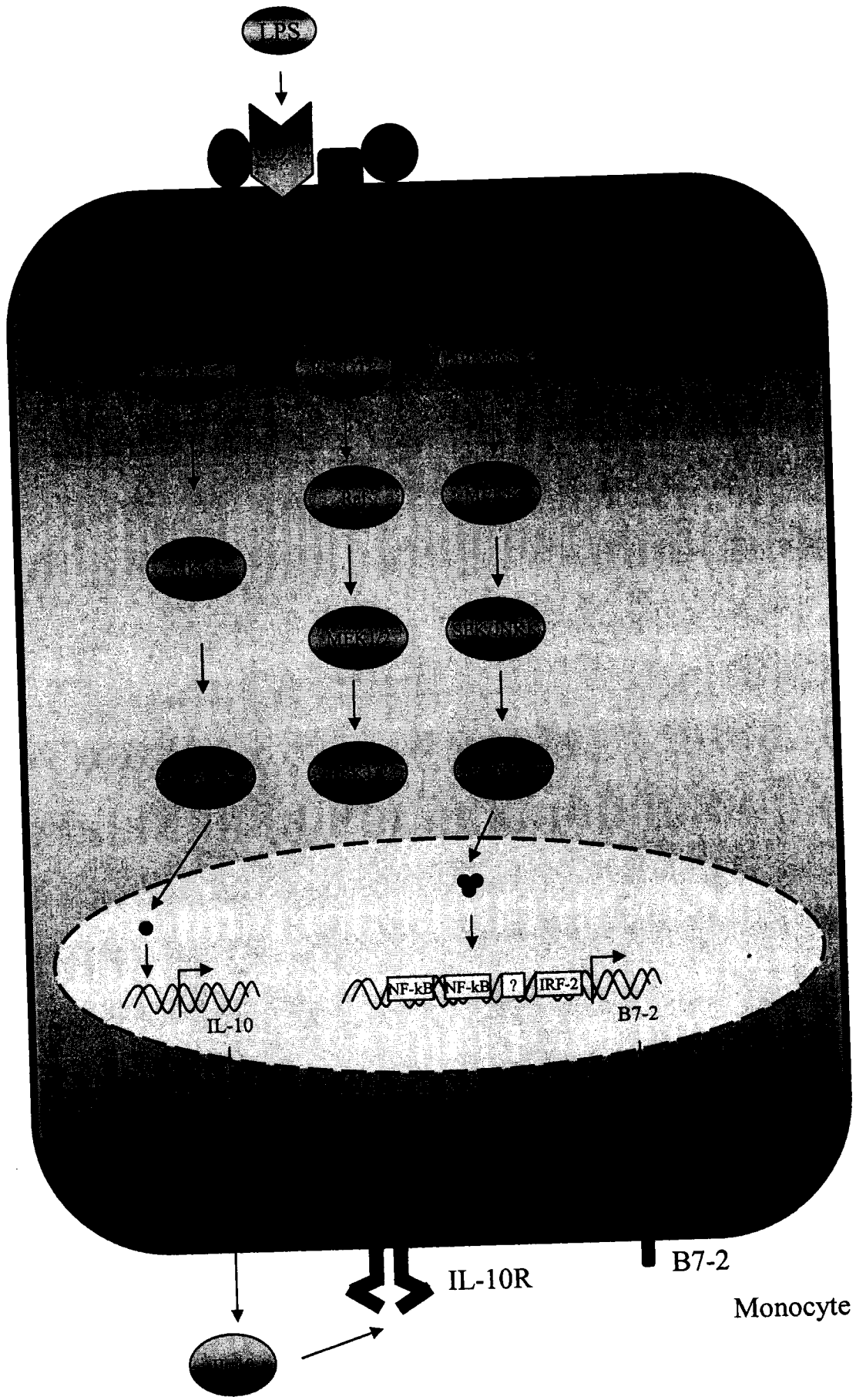

Monocyte

CHAPTER 6:
CONCLUSION, SIGNIFICANCE, AND FUTURE DIRECTIONS

The overall findings of my thesis research work demonstrated that the regulation of B7-1 and B7-2 co-stimulatory molecules by LPS in human monocytic cells occur through a shared JNK signaling pathway but through distinct transcription factors. The models are shown in Fig. 5-1 and Fig. 5-2.

I investigated the role of mitogen activated protein kinases in the regulation of B7-1 and B7-2 expression in human monocytes and the promonocytic THP-1 cells. By using SP600125, dexamethasone, curcumin, dominant negative SEK kinase, and/or siRNAs for JNK to inhibit JNK activation, I proved that LPS-induced B7-1 and B7-2 expression is regulated by JNK MAPK in human monocytic cells. The regulation of B7-2 expression is complex as anti-IL-10 antibodies can abrogate the effect of LPS on B7-2 expression. Further investigations revealed the distinct involvement of p38 in IL-10 dependent, and JNK in IL-10-independent regulation of B7-2 expression in LPS-stimulated monocytic cells. It appears that both B7-1 and B7-2 share the same signaling pathway as both are regulated by the JNK MAP kinases. This is not surprising as JNK plays a pivotal role in a wide biological setting. For instance, it is activated by stress responses such as ultraviolet light, heat shock, osmotic shock, and growth factors. In turn, JNK activation leads to the expression of a broad array of genes including IL-2, IFN- γ , and TNF- α .

To pursue the clinical relevance of JNK on B7-1 expression, one could determine if the induction of B7-1 by LPS is inhibited in JNK knockout mice or whether the severity of autoimmune diseases is reduced in experimental animal models. In the development of new drug candidates, it has always been known that there is enormous therapeutic potential in targeting kinases using inhibitors. As a result, small molecule

inhibitors of JNK could be employed to modulate B7-1 expression in the treatment of autoimmune diseases.

As for the latter part of my thesis work, I was able to identify the regulatory elements on the B7-1 and B7-2 promoters and characterize the transcription factors that are necessary for the promoter activities in human monocytic cells. It appears that the regulation of B7-1 and B7-2 occur through distinct cis elements and DNA binding proteins. This is to be expected as the regulation of gene expression is usually tightly controlled and sequence specific.

In my work, I pinpointed a distinct B7-1 responsive element corresponding to the interferon regulatory factor-7 binding site, in the B7-1 promoter responsible for the regulation of LPS-induced B7-1 transcription. Furthermore, SP600125 and dexamethasone inhibited LPS-induced IRF-7 activity. Taken together, these results suggest that LPS-induced B7-1 transcription in human monocytic cells may be regulated by JNK-mediated activation of the IRF-7 transcription factor. As for future experiments, it would be interesting to explore the importance of IRF-7 in B7-1 regulation. A strategy would be to target the B7-1 responsive element by deletion using homologous recombination. The immune responses of B7-1 responsive element knockout mice can then be characterized such as determining their sensitivity to viral infections. This will provide insight to the biological significance of the B7-1 responsive element. It would also be interesting to study the involvement of IRF-7 in the regulation of B7-1 by utilizing IRF-7 null mice.

Reporter gene analysis of the B7-2 promoter demonstrated strong B7-2 promoter activity. This corresponds to its cell surface expression pattern in monocytes, where B7-2

is constitutively expressed and is expressed at higher levels than B7-1. Sequential deletion and mutational reporter gene analysis of the constructs determined several cis-acting elements. The positive regulatory segments regions consisted of NF- κ B, an unidentified element, and IRF-2, which appear to work synergistically in the transcriptional regulation of the B7-2 gene. Further studies can be performed to confirm the cooperative role of the cis elements in regulating B7-2. An interesting avenue would be to conduct full-length B7-2 promoter analysis containing mutations for all 3 NF- κ B, IRF-2, and the unidentified binding elements. It would also be exciting to characterize the transcription factor(s) that bind to the unidentified binding site by pull-down assay and mass spectrometric analysis as it may lead to the identification of novel transcription factor(s).

To this day, it remains unclear whether B7-1 and B7-2 perform distinct or overlapping functions. It is widely believed that since B7-2 is constitutively expressed on a number of APCs, it engages the T cells earlier than B7-1. But it seems that their roles are dependent on the type of APC it encounters and the surrounding conditions they are in. This probably coincides with that of the regulation of B7-1 and B7-2. I would expect that the regulation of B7-1 and B7-2 vary, depending on the type of APC and the stimulus it encounters. There could be a shared upstream event such as the JNK signaling pathway, whereas divergence occurs at the promoter level during the control of gene expression.

In summary, I was able to characterize the signaling and transcriptional regulation of the B7-1 and B7-2 molecules in human monocytes. It appears that both B7-1 and B7-2 share the same signaling pathway as both were regulated by the JNK MAP kinases.

However, the transcriptional regulation of B7-1 and B7-2 gene expression differ considerably. The B7-1 promoter contained one critical positive regulatory region that corresponded to the IRF-7 binding element. Deletion or disruption of this IRF-7 binding element significantly decreased the promoter activity for the B7-1 gene. Conversely, transcriptional regulation of the B7-2 gene appears to be more complex. B7-2 promoter activity appears to require the interactions of several cis acting elements, namely NF- κ B, an unidentified element, and IRF-2. Keep in mind that the control of gene expression in eukaryotes not only involves promoter elements and transcription factors but other checkpoints such as chromatin structure, enhancers, transcript stability, etc. Therefore, one future avenue would be to pursue chromatin remodeling analysis in the regulation of B7-1 and B7-2.

My findings should extend our understanding of the molecular mechanisms in the regulation of B7-1 and B7-2 expression and this may pave the way in the development of therapeutic strategies by the identification of potential targets. Modulation of the CD28/B7 co-stimulatory pathway may lead to the treatment of diseases such as autoimmunity, cancer, organ transplantation, and graft-versus-host diseases.

Reference List

1. Romagnani, S. 1995. Biology of human TH1 and TH2 cells. *J.Clin.Immunol.* 15:121-129.
2. Mosmann, T. R., H. Cherwinski, M. W. Bond, M. A. Giedlin, and R. L. Coffman. 1986. Two types of murine helper T cell clone. I. Definition according to profiles of lymphokine activities and secreted proteins. *J.Immunol.* 136:2348-2357.
3. Kanagawa, O., B. A. Vaupel, S. Gayama, G. Koehler, and M. Kopf. 1993. Resistance of mice deficient in IL-4 to retrovirus-induced immunodeficiency syndrome (MAIDS). *Science* 262:240-242.
4. Bretscher, P. and M. Cohn. 1970. A theory of self-nonsel self discrimination. *Science* 169:1042-1049.
5. Peach, R. J., J. Bajorath, J. Naemura, G. Leytze, J. Greene, A. Aruffo, and P. S. Linsley. 1995. Both extracellular immunoglobulin-like domains of CD80 contain residues critical for binding T cell surface receptors CTLA-4 and CD28. *J.Biol.Chem.* 270:21181-21187.
6. Linsley, P. S., J. L. Greene, W. Brady, J. Bajorath, J. A. Ledbetter, and R. Peach. 1994. Human B7-1 (CD80) and B7-2 (CD86) bind with similar avidities but distinct kinetics to CD28 and CTLA-4 receptors. *Immunity* 1:793-801.
7. van der Merwe, P. A., D. L. Bodian, S. Daenke, P. Linsley, and S. J. Davis. 1997. CD80 (B7-1) binds both CD28 and CTLA-4 with a low affinity and very fast kinetics. *J.Exp.Med.* 185:393-403.
8. Morton, P. A., X. T. Fu, J. A. Stewart, K. S. Giacoletto, S. L. White, C. E. Leysath, R. J. Evans, J. J. Shieh, and R. W. Karr. 1996. Differential effects of CTLA-4 substitutions on the binding of human CD80 (B7-1) and CD86 (B7-2). *J.Immunol.* 156:1047-1054.
9. Greenfield, E. A., K. A. Nguyen, and V. K. Kuchroo. 1998. CD28/B7 costimulation: a review. *Crit Rev.Immunol.* 18:389-418.
10. Selvakumar, A., B. K. Mohanraj, R. L. Eddy, T. B. Shows, P. C. White, and B. Dupont. 1992. Genomic organization and chromosomal location of the human gene encoding the B-lymphocyte activation antigen B7. *Immunogenetics* 36:175-181.
11. Jellis, C. L., S. S. Wang, P. Rennert, F. Borriello, A. H. Sharpe, N. R. Green, and G. S. Gray. 1995. Genomic organization of the gene coding for the costimulatory human B-lymphocyte antigen B7-2 (CD86). *Immunogenetics* 42:85-89.

12. Ling, V., P. W. Wu, H. F. Finnerty, K. M. Bean, V. Spaulding, L. A. Fouser, J. P. Leonard, S. E. Hunter, R. Zollner, J. L. Thomas, J. S. Miyashiro, K. A. Jacobs, and M. Collins. 2000. Cutting edge: identification of GL50, a novel B7-like protein that functionally binds to ICOS receptor. *J.Immunol.* 164:1653-1657.
13. Yoshinaga, S. K., J. S. Whoriskey, S. D. Khare, U. Sarmiento, J. Guo, T. Horan, G. Shih, M. Zhang, M. A. Coccia, T. Kohno, A. Tafuri-Bladt, D. Brankow, P. Campbell, D. Chang, L. Chiu, T. Dai, G. Duncan, G. S. Elliott, A. Hui, S. M. McCabe, S. Scully, A. Shahinian, C. L. Shaklee, G. Van, T. W. Mak, and G. Senaldi. 1999. T-cell co-stimulation through B7RP-1 and ICOS. *Nature* 402:827-832.
14. Wang, S., G. Zhu, A. I. Chapoval, H. Dong, K. Tamada, J. Ni, and L. Chen. 2000. Costimulation of T cells by B7-H2, a B7-like molecule that binds ICOS. *Blood* 96:2808-2813.
15. Carreno, B. M. and M. Collins. 2002. The B7 family of ligands and its receptors: new pathways for costimulation and inhibition of immune responses. *Annu.Rev.Immunol.* 20:29-53.
16. Aicher, A., M. Hayden-Ledbetter, W. A. Brady, A. Pezzutto, G. Richter, D. Magaletti, S. Buckwalter, J. A. Ledbetter, and E. A. Clark. 2000. Characterization of human inducible costimulator ligand expression and function. *J.Immunol.* 164:4689-4696.
17. Freeman, G. J., A. J. Long, Y. Iwai, K. Bourque, T. Chernova, H. Nishimura, L. J. Fitz, N. Malenkovich, T. Okazaki, M. C. Byrne, H. F. Horton, L. Fouser, L. Carter, V. Ling, M. R. Bowman, B. M. Carreno, M. Collins, C. R. Wood, and T. Honjo. 2000. Engagement of the PD-1 immunoinhibitory receptor by a novel B7 family member leads to negative regulation of lymphocyte activation. *J.Exp.Med.* 192:1027-1034.
18. Latchman, Y., C. R. Wood, T. Chernova, D. Chaudhary, M. Borde, I. Chernova, Y. Iwai, A. J. Long, J. A. Brown, R. Nunes, E. A. Greenfield, K. Bourque, V. A. Boussiotis, L. L. Carter, B. M. Carreno, N. Malenkovich, H. Nishimura, T. Okazaki, T. Honjo, A. H. Sharpe, and G. J. Freeman. 2001. PD-L2 is a second ligand for PD-1 and inhibits T cell activation. *Nat.Immunol.* 2:261-268.
19. Yamazaki, T., H. Akiba, H. Iwai, H. Matsuda, M. Aoki, Y. Tanno, T. Shin, H. Tsuchiya, D. M. Pardoll, K. Okumura, M. Azuma, and H. Yagita. 2002. Expression of programmed death 1 ligands by murine T cells and APC. *J.Immunol.* 169:5538-5545.
20. Chen, L. 2004. Co-inhibitory molecules of the B7-CD28 family in the control of T-cell immunity. *Nat.Rev.Immunol.* 4:336-347.

21. Chapoval, A. I., J. Ni, J. S. Lau, R. A. Wilcox, D. B. Flies, D. Liu, H. Dong, G. L. Sica, G. Zhu, K. Tamada, and L. Chen. 2001. B7-H3: a costimulatory molecule for T cell activation and IFN-gamma production. *Nat.Immunol.* 2:269-274.
22. Sica, G. L., I. H. Choi, G. Zhu, K. Tamada, S. D. Wang, H. Tamura, A. I. Chapoval, D. B. Flies, J. Bajorath, and L. Chen. 2003. B7-H4, a molecule of the B7 family, negatively regulates T cell immunity. *Immunity* 18:849-861.
23. Zang, X., P. Loke, J. Kim, K. Murphy, R. Waitz, and J. P. Allison. 2003. B7x: a widely expressed B7 family member that inhibits T cell activation. *Proc.Natl.Acad.Sci.U.S.A* 100:10388-10392.
24. McLellan, A. D., G. C. Starling, L. A. Williams, B. D. Hock, and D. N. Hart. 1995. Activation of human peripheral blood dendritic cells induces the CD86 co-stimulatory molecule. *Eur.J.Immunol.* 25:2064-2068.
25. Hathcock, K. S., G. Laszlo, C. Pucillo, P. Linsley, and R. J. Hodes. 1994. Comparative analysis of B7-1 and B7-2 costimulatory ligands: expression and function. *J.Exp.Med.* 180:631-640.
26. Engel, P., J. G. Gribben, G. J. Freeman, L. J. Zhou, Y. Nozawa, M. Abe, L. M. Nadler, H. Wakasa, and T. F. Tedder. 1994. The B7-2 (B70) costimulatory molecule expressed by monocytes and activated B lymphocytes is the CD86 differentiation antigen. *Blood* 84:1402-1407.
27. Kawamura, T. and M. Furue. 1995. Comparative analysis of B7-1 and B7-2 expression in Langerhans cells: differential regulation by T helper type 1 and T helper type 2 cytokines. *Eur.J.Immunol.* 25:1913-1917.
28. Rattis, F. M., J. Peguet-Navarro, M. J. Staquet, C. Dezutter-Dambuyant, P. Courtellemont, G. Redziniak, and D. Schmitt. 1996. Expression and function of B7-1 (CD80) and B7-2 (CD86) on human epidermal Langerhans cells. *Eur.J.Immunol.* 26:449-453.
29. Fleischer, J., E. Soeth, N. Reiling, E. Grage-Griebenow, H. D. Flad, and M. Ernst. 1996. Differential expression and function of CD80 (B7-1) and CD86 (B7-2) on human peripheral blood monocytes. *Immunology* 89:592-598.
30. Schmittel, A., C. Scheibenbogen, and U. Keilholz. 1995. Lipopolysaccharide effectively up-regulates B7-1 (CD80) expression and costimulatory function of human monocytes. *Scand.J.Immunol.* 42:701-704.
31. Wyss-Coray, T., D. Mauri-Hellweg, K. Baumann, F. Bettens, R. Grunow, and W. J. Pichler. 1993. The B7 adhesion molecule is expressed on activated human T cells: functional involvement in T-T cell interactions. *Eur.J.Immunol.* 23:2175-2180.

32. Tatari-Calderone, Z., R. T. Semnani, T. B. Nutman, J. Schlom, and H. Sabzevari. 2002. Acquisition of CD80 by human T cells at early stages of activation: functional involvement of CD80 acquisition in T cell to T cell interaction. *J.Immunol.* 169:6162-6169.
33. Greenfield, E. A., E. Howard, T. Paradis, K. Nguyen, F. Benazzo, P. McLean, P. Hollsberg, G. Davis, D. A. Hafler, A. H. Sharpe, G. J. Freeman, and V. K. Kuchroo. 1997. B7.2 expressed by T cells does not induce CD28-mediated costimulatory activity but retains CTLA4 binding: implications for induction of antitumor immunity to T cell tumors. *J.Immunol.* 158:2025-2034.
34. Hollsberg, P., C. Scholz, D. E. Anderson, E. A. Greenfield, V. K. Kuchroo, G. J. Freeman, and D. A. Hafler. 1997. Expression of a hypoglycosylated form of CD86 (B7-2) on human T cells with altered binding properties to CD28 and CTLA-4. *J.Immunol.* 159:4799-4805.
35. Boussiotis, V. A., G. J. Freeman, J. G. Gribben, J. Daley, G. Gray, and L. M. Nadler. 1993. Activated human B lymphocytes express three CTLA-4 counterreceptors that costimulate T-cell activation. *Proc.Natl.Acad.Sci.U.S.A* 90:11059-11063.
36. Curiel, R. E., C. S. Garcia, S. Rottschaefer, M. C. Bosco, and I. Espinoza-Delgado. 1999. Enhanced B7-2 gene expression by interferon-gamma in human monocytic cells is controlled through transcriptional and posttranscriptional mechanisms. *Blood* 94:1782-1789.
37. Creery, W. D., F. Diaz-Mitoma, L. Fillion, and A. Kumar. 1996. Differential modulation of B7-1 and B7-2 isoform expression on human monocytes by cytokines which influence the development of T helper cell phenotype. *Eur.J.Immunol.* 26:1273-1277.
38. Mosmann, T. R. and S. Sad. 1996. The expanding universe of T-cell subsets: Th1, Th2 and more. *Immunol.Today* 17:138-146.
39. Rulifson, I. C., A. I. Sperling, P. E. Fields, F. W. Fitch, and J. A. Bluestone. 1997. CD28 costimulation promotes the production of Th2 cytokines. *J.Immunol.* 158:658-665.
40. Freeman, G. J., V. A. Boussiotis, A. Anumanthan, G. M. Bernstein, X. Y. Ke, P. D. Rennert, G. S. Gray, J. G. Gribben, and L. M. Nadler. 1995. B7-1 and B7-2 do not deliver identical costimulatory signals, since B7-2 but not B7-1 preferentially costimulates the initial production of IL-4. *Immunity* 2:523-532.
41. Brown, J. A., R. G. Titus, N. Nabavi, and L. H. Glimcher. 1996. Blockade of CD86 ameliorates Leishmania major infection by down-regulating the Th2 response. *J.Infect.Dis.* 174:1303-1308.

42. Petro, T. M., S. S. Chen, and R. B. Panther. 1995. Effect of CD80 and CD86 on T cell cytokine production. *Immunol.Invest* 24:965-976.
43. Racke, M. K., D. E. Scott, L. Quigley, G. S. Gray, R. Abe, C. H. June, and P. J. Perrin. 1995. Distinct roles for B7-1 (CD-80) and B7-2 (CD-86) in the initiation of experimental allergic encephalomyelitis. *J.Clin.Invest* 96:2195-2203.
44. Perrin, P. J., D. Scott, T. A. Davis, G. S. Gray, M. J. Doggett, R. Abe, C. H. June, and M. K. Racke. 1996. Opposing effects of CTLA4-Ig and anti-CD80 (B7-1) plus anti-CD86 (B7-2) on experimental allergic encephalomyelitis. *J.Neuroimmunol.* 65:31-39.
45. Schweitzer, A. N. and A. H. Sharpe. 1999. Mutual regulation between B7-1 (CD80) expressed on T cells and IL-4. *J.Immunol.* 163:4819-4825.
46. Flores Villanueva, P. O., H. Reiser, and M. J. Stadecker. 1994. Regulation of T helper cell responses in experimental murine schistosomiasis by IL-10. Effect on expression of B7 and B7-2 costimulatory molecules by macrophages. *J.Immunol.* 153:5190-5199.
47. Hernandez, H. J., A. H. Sharpe, and M. J. Stadecker. 1999. Experimental murine schistosomiasis in the absence of B7 costimulatory molecules: reversal of elicited T cell cytokine profile and partial inhibition of egg granuloma formation. *J.Immunol.* 162:2884-2889.
48. Ranheim, E. A. and T. J. Kipps. 1994. Elevated expression of CD80 (B7/BB1) and other accessory molecules on synovial fluid mononuclear cell subsets in rheumatoid arthritis. *Arthritis Rheum.* 37:1637-1646.
49. Wong, F. S., I. Visintin, L. Wen, J. Granata, R. Flavell, and C. A. Janeway. 1998. The role of lymphocyte subsets in accelerated diabetes in nonobese diabetic-rat insulin promoter-B7-1 (NOD-RIP-B7-1) mice. *J.Exp.Med.* 187:1985-1993.
50. Lenschow, D. J., S. C. Ho, H. Sattar, L. Rhee, G. Gray, N. Nabavi, K. C. Herold, and J. A. Bluestone. 1995. Differential effects of anti-B7-1 and anti-B7-2 monoclonal antibody treatment on the development of diabetes in the nonobese diabetic mouse. *J.Exp.Med.* 181:1145-1155.
51. Nakajima, A., M. Azuma, S. Kodera, S. Nuriya, A. Terashi, M. Abe, S. Hirose, T. Shirai, H. Yagita, and K. Okumura. 1995. Preferential dependence of autoantibody production in murine lupus on CD86 costimulatory molecule. *Eur.J.Immunol.* 25:3060-3069.
52. Kuchroo, V. K., M. P. Das, J. A. Brown, A. M. Ranger, S. S. Zamvil, R. A. Sobel, H. L. Weiner, N. Nabavi, and L. H. Glimcher. 1995. B7-1 and B7-2 costimulatory molecules activate differentially the Th1/Th2 developmental pathways: application to autoimmune disease therapy. *Cell* 80:707-718.

53. Racke, M. K., D. E. Scott, L. Quigley, G. S. Gray, R. Abe, C. H. June, and P. J. Perrin. 1995. Distinct roles for B7-1 (CD-80) and B7-2 (CD-86) in the initiation of experimental allergic encephalomyelitis. *J.Clin.Invest* 96:2195-2203.
54. Townsend, S. E. and J. P. Allison. 1993. Tumor rejection after direct costimulation of CD8+ T cells by B7-transfected melanoma cells. *Science* 259:368-370.
55. Baskar, S., S. Ostrand-Rosenberg, N. Nabavi, L. M. Nadler, G. J. Freeman, and L. H. Glimcher. 1993. Constitutive expression of B7 restores immunogenicity of tumor cells expressing truncated major histocompatibility complex class II molecules. *Proc.Natl.Acad.Sci.U.S.A* 90:5687-5690.
56. Yang, G., K. E. Hellstrom, I. Hellstrom, and L. Chen. 1995. Antitumor immunity elicited by tumor cells transfected with B7-2, a second ligand for CD28/CTLA-4 costimulatory molecules. *J.Immunol.* 154:2794-2800.
57. Matulonis, U., C. Dosiou, G. Freeman, C. Lamont, P. Mauch, L. M. Nadler, and J. D. Griffin. 1996. B7-1 is superior to B7-2 costimulation in the induction and maintenance of T cell-mediated antileukemia immunity. Further evidence that B7-1 and B7-2 are functionally distinct. *J.Immunol.* 156:1126-1131.
58. Wetzler, L. M., Y. Ho, and H. Reiser. 1996. Neisserial porins induce B lymphocytes to express costimulatory B7-2 molecules and to proliferate. *J.Exp.Med.* 183:1151-1159.
59. Kaye, P. M., N. J. Rogers, A. J. Curry, and J. C. Scott. 1994. Deficient expression of co-stimulatory molecules on Leishmania-infected macrophages. *Eur.J.Immunol.* 24:2850-2854.
60. Saha, B., G. Das, H. Vohra, N. K. Ganguly, and G. C. Mishra. 1994. Macrophage-T cell interaction in experimental mycobacterial infection. Selective regulation of co-stimulatory molecules on Mycobacterium-infected macrophages and its implication in the suppression of cell-mediated immune response. *Eur.J.Immunol.* 24:2618-2624.
61. Subauste, C. S., M. R. de Waal, and F. Fuh. 1998. Role of CD80 (B7.1) and CD86 (B7.2) in the immune response to an intracellular pathogen. *J.Immunol.* 160:1831-1840.
62. Corry, D. B., S. L. Reiner, P. S. Linsley, and R. M. Locksley. 1994. Differential effects of blockade of CD28-B7 on the development of Th1 or Th2 effector cells in experimental leishmaniasis. *J.Immunol.* 153:4142-4148.
63. Bashuda, H., K. Seino, M. Kano, K. Sato, M. Azuma, H. Yagita, and K. Okumura. 1996. Specific acceptance of cardiac allografts after treatment with antibodies to CD80 and CD86 in mice. *Transplant Proc.* 28:1039-1041.

64. Lin, H., S. F. Bolling, P. S. Linsley, R. Q. Wei, D. Gordon, C. B. Thompson, and L. A. Turka. 1993. Long-term acceptance of major histocompatibility complex mismatched cardiac allografts induced by CTLA4Ig plus donor-specific transfusion. *J.Exp.Med.* 178:1801-1806.
65. Turka, L. A., P. S. Linsley, H. Lin, W. Brady, J. M. Leiden, R. Q. Wei, M. L. Gibson, X. G. Zheng, S. Myrdal, D. Gordon, and . 1992. T-cell activation by the CD28 ligand B7 is required for cardiac allograft rejection in vivo. *Proc.Natl.Acad.Sci.U.S.A* 89:11102-11105.
66. Lenschow, D. J., Y. Zeng, J. R. Thistlethwaite, A. Montag, W. Brady, M. G. Gibson, P. S. Linsley, and J. A. Bluestone. 1992. Long-term survival of xenogeneic pancreatic islet grafts induced by CTLA4Ig. *Science* 257:789-792.
67. Freeman, G. J., A. S. Freedman, J. M. Segil, G. Lee, J. F. Whitman, and L. M. Nadler. 1989. B7, a new member of the Ig superfamily with unique expression on activated and neoplastic B cells. *J.Immunol.* 143:2714-2722.
68. Yokochi, T., R. D. Holly, and E. A. Clark. 1982. B lymphoblast antigen (BB-1) expressed on Epstein-Barr virus-activated B cell blasts, B lymphoblastoid cell lines, and Burkitt's lymphomas. *J.Immunol.* 128:823-827.
69. Nabavi, N., G. J. Freeman, A. Gault, D. Godfrey, L. M. Nadler, and L. H. Glimcher. 1992. Signalling through the MHC class II cytoplasmic domain is required for antigen presentation and induces B7 expression. *Nature* 360:266-268.
70. Freedman, A. S., G. J. Freeman, K. Rhyhart, and L. M. Nadler. 1991. Selective induction of B7/BB-1 on interferon-gamma stimulated monocytes: a potential mechanism for amplification of T cell activation through the CD28 pathway. *Cell Immunol.* 137:429-437.
71. Young, J. W., L. Koulova, S. A. Soergel, E. A. Clark, R. M. Steinman, and B. Dupont. 1992. The B7/BB1 antigen provides one of several costimulatory signals for the activation of CD4+ T lymphocytes by human blood dendritic cells in vitro. *J.Clin.Invest* 90:229-237.
72. Hart, D. N., G. C. Starling, V. L. Calder, and N. S. Fernando. 1993. B7/BB-1 is a leucocyte differentiation antigen on human dendritic cells induced by activation. *Immunology* 79:616-620.
73. Sansom, D. M. and N. D. Hall. 1993. B7/BB1, the ligand for CD28, is expressed on repeatedly activated human T cells in vitro. *Eur.J.Immunol.* 23:295-298.
74. Augustin, M., A. Dietrich, R. Niedner, A. Kapp, E. Schopf, J. A. Ledbetter, W. Brady, P. S. Linsley, and J. C. Simon. 1993. Phorbol-12-myristate-13-acetate-treated human keratinocytes express B7-like molecules that serve a costimulatory role in T-cell activation. *J.Invest Dermatol.* 100:275-281.

75. Nasir, A., B. Ferbel, and A. A. Gaspari. 1995. Human keratinocytes regulate their expression of B7/BB-1 antigen by a unique, calcium-dependent mechanism. *J.Invest Dermatol.* 104:763-767.
76. Van Gool, S. W., P. Vandenberghe, M. de Boer, and J. L. Ceuppens. 1996. CD80, CD86 and CD40 provide accessory signals in a multiple-step T-cell activation model. *Immunol.Rev.* 153:47-83.
77. Bondeson, J., K. A. Browne, F. M. Brennan, B. M. Foxwell, and M. Feldmann. 1999. Selective regulation of cytokine induction by adenoviral gene transfer of IkappaBalpha into human macrophages: lipopolysaccharide-induced, but not zymosan-induced, proinflammatory cytokines are inhibited, but IL-10 is nuclear factor-kappaB independent. *J.Immunol.* 162:2939-2945.
78. de Waal, M. R., J. Abrams, B. Bennett, C. G. Figdor, and J. E. de Vries. 1991. Interleukin 10(IL-10) inhibits cytokine synthesis by human monocytes: an autoregulatory role of IL-10 produced by monocytes. *J.Exp.Med.* 174:1209-1220.
79. Morrison, D. C. and J. L. Ryan. 1979. Bacterial endotoxins and host immune responses. *Adv.Immunol.* 28:293-450.
80. Cohen, J. 2002. The immunopathogenesis of sepsis. *Nature* 420:885-891.
81. Deitch, E. A. 1992. Multiple organ failure. Pathophysiology and potential future therapy. *Ann.Surg.* 216:117-134.
82. Azuma, M., D. Ito, H. Yagita, K. Okumura, J. H. Phillips, L. L. Lanier, and C. Somoza. 1993. B70 antigen is a second ligand for CTLA-4 and CD28. *Nature* 366:76-79.
83. Azuma, M., H. Yssel, J. H. Phillips, H. Spits, and L. L. Lanier. 1993. Functional expression of B7/BB1 on activated T lymphocytes. *J.Exp.Med.* 177:845-850.
84. Prabhu Das, M. R., S. S. Zamvil, F. Borriello, H. L. Weiner, A. H. Sharpe, and V. K. Kuchroo. 1995. Reciprocal expression of co-stimulatory molecules, B7-1 and B7-2, on murine T cells following activation. *Eur.J.Immunol.* 25:207-211.
85. Yssel, H., P. V. Schneider, and L. L. Lanier. 1993. Interleukin-7 specifically induces the B7/BB1 antigen on human cord blood and peripheral blood T cells and T cell clones. *Int.Immunol.* 5:753-759.
86. Ranheim, E. A. and T. J. Kipps. 1995. Tumor necrosis factor-alpha facilitates induction of CD80 (B7-1) and CD54 on human B cells by activated T cells: complex regulation by IL-4, IL-10, and CD40L. *Cell Immunol.* 161:226-235.
87. Stack, R. M., D. J. Lenschow, G. S. Gray, J. A. Bluestone, and F. W. Fitch. 1994. IL-4 treatment of small splenic B cells induces costimulatory molecules B7-1 and B7-2. *J.Immunol.* 152:5723-5733.

88. Larsen, C. P., S. C. Ritchie, R. Hendrix, P. S. Linsley, K. S. Hathcock, R. J. Hodes, R. P. Lowry, and T. C. Pearson. 1994. Regulation of immunostimulatory function and costimulatory molecule (B7-1 and B7-2) expression on murine dendritic cells. *J.Immunol.* 152:5208-5219.
89. Girndt, M., U. Sester, H. Kaul, F. Hunger, and H. Kohler. 1998. Glucocorticoids inhibit activation-dependent expression of costimulatory molecule B7-1 in human monocytes. *Transplantation* 66:370-375.
90. Willems, F., A. Marchant, J. P. Delville, C. Gerard, A. Delvaux, T. Velu, M. de Boer, and M. Goldman. 1994. Interleukin-10 inhibits B7 and intercellular adhesion molecule-1 expression on human monocytes. *Eur.J.Immunol.* 24:1007-1009.
91. Lim, W., W. Ma, K. Gee, S. Aucoin, D. Nandan, F. Diaz-Mitoma, M. Kozlowski, and A. Kumar. 2002. Distinct role of p38 and c-Jun N-terminal kinases in IL-10-dependent and IL-10-independent regulation of the costimulatory molecule B7.2 in lipopolysaccharide-stimulated human monocytic cells. *J.Immunol.* 168:1759-1769.
92. Cambier, J. C. and J. T. Ransom. 1987. Molecular mechanisms of transmembrane signaling in B lymphocytes. *Annu.Rev.Immunol.* 5:175-199.
93. Samelson, L. E. and R. D. Klausner. 1992. Tyrosine kinases and tyrosine-based activation motifs. Current research on activation via the T cell antigen receptor. *J.Biol.Chem.* 267:24913-24916.
94. Simon, M. I., M. P. Strathmann, and N. Gautam. 1991. Diversity of G proteins in signal transduction. *Science* 252:802-808.
95. James, S. R. and C. P. Downes. 1997. Structural and mechanistic features of phospholipases C: effectors of inositol phospholipid-mediated signal transduction. *Cell Signal.* 9:329-336.
96. Spiegel, S., D. Foster, and R. Kolesnick. 1996. Signal transduction through lipid second messengers. *Curr.Opin.Cell Biol.* 8:159-167.
97. Schorey, J. S. and A. M. Cooper. 2003. Macrophage signalling upon mycobacterial infection: the MAP kinases lead the way. *Cell Microbiol.* 5:133-142.
98. Lange-Carter, C. A., C. M. Pleiman, A. M. Gardner, K. J. Blumer, and G. L. Johnson. 1993. A divergence in the MAP kinase regulatory network defined by MEK kinase and Raf. *Science* 260:315-319.
99. Barber, S. A., P. Y. Perera, R. McNally, and S. N. Vogel. 1995. The serine/threonine phosphatase inhibitor, calyculin A, inhibits and dissociates macrophage responses to lipopolysaccharide. *J.Immunol.* 155:1404-1410.

100. Stefanova, I., M. L. Corcoran, E. M. Horak, L. M. Wahl, J. B. Bolen, and I. D. Horak. 1993. Lipopolysaccharide induces activation of CD14-associated protein tyrosine kinase p53/56lyn. *J.Biol.Chem.* 268:20725-20728.
101. Bakouche, O., J. L. Moreau, and L. B. Lachman. 1992. Secretion of IL-1: role of protein kinase C. *J.Immunol.* 148:84-91.
102. Ohmori, Y. and T. A. Hamilton. 1992. Ca²⁺ and calmodulin selectively regulate lipopolysaccharide-inducible cytokine mRNA expression in murine peritoneal macrophages. *J.Immunol.* 148:538-545.
103. Weinstein, S. L., J. S. Sanghera, K. Lemke, A. L. DeFranco, and S. L. Pelech. 1992. Bacterial lipopolysaccharide induces tyrosine phosphorylation and activation of mitogen-activated protein kinases in macrophages. *J.Biol.Chem.* 267:14955-14962.
104. Karima, R., S. Matsumoto, H. Higashi, and K. Matsushima. 1999. The molecular pathogenesis of endotoxic shock and organ failure. *Mol.Med.Today* 5:123-132.
105. Ulevitch, R. J. and P. S. Tobias. 1999. Recognition of gram-negative bacteria and endotoxin by the innate immune system. *Curr.Opin.Immunol.* 11:19-22.
106. Caroff, M., D. Karibian, J. M. Cavaillon, and N. Haeffner-Cavaillon. 2002. Structural and functional analyses of bacterial lipopolysaccharides. *Microbes Infect.* 4:915-926.
107. Aderem, A. and R. J. Ulevitch. 2000. Toll-like receptors in the induction of the innate immune response. *Nature* 406:782-787.
108. Haziot, A., E. Ferrero, F. Kontgen, N. Hijiya, S. Yamamoto, J. Silver, C. L. Stewart, and S. M. Goyert. 1996. Resistance to endotoxin shock and reduced dissemination of gram-negative bacteria in CD14-deficient mice. *Immunity* 4:407-414.
109. Bowie, A. and L. A. O'Neill. 2000. The interleukin-1 receptor/Toll-like receptor superfamily: signal generators for pro-inflammatory interleukins and microbial products. *J.Leukoc.Biol.* 67:508-514.
110. Martin, M. U. and H. Wesche. 2002. Summary and comparison of the signaling mechanisms of the Toll/interleukin-1 receptor family. *Biochim.Biophys.Acta* 1592:265-280.
111. Takeuchi, O., K. Hoshino, T. Kawai, H. Sanjo, H. Takada, T. Ogawa, K. Takeda, and S. Akira. 1999. Differential roles of TLR2 and TLR4 in recognition of gram-negative and gram-positive bacterial cell wall components. *Immunity* 11:443-451.

112. Muzio, M., N. Polentarutti, D. Bosisio, P. P. Manoj Kumar, and A. Mantovani. 2000. Toll-like receptor family and signalling pathway. *Biochem.Soc.Trans.* 28:563-566.
113. Johnson, G. L. and R. Lapadat. 2002. Mitogen-activated protein kinase pathways mediated by ERK, JNK, and p38 protein kinases. *Science* 298:1911-1912.
114. Cobb, M. H. and E. J. Goldsmith. 1995. How MAP kinases are regulated. *J.Biol.Chem.* 270:14843-14846.
115. Chen, Z., T. B. Gibson, F. Robinson, L. Silvestro, G. Pearson, B. Xu, A. Wright, C. Vanderbilt, and M. H. Cobb. 2001. MAP kinases. *Chem.Rev.* 101:2449-2476.
116. Lewis, T. S., P. S. Shapiro, and N. G. Ahn. 1998. Signal transduction through MAP kinase cascades. *Adv.Cancer Res.* 74:49-139.
117. Seger, R. and E. G. Krebs. 1995. The MAPK signaling cascade. *FASEB J.* 9:726-735.
118. Hibi, M., A. Lin, T. Smeal, A. Minden, and M. Karin. 1993. Identification of an oncoprotein- and UV-responsive protein kinase that binds and potentiates the c-Jun activation domain. *Genes Dev.* 7:2135-2148.
119. Kyriakis, J. M., P. Banerjee, E. Nikolakaki, T. Dai, E. A. Rubie, M. F. Ahmad, J. Avruch, and J. R. Woodgett. 1994. The stress-activated protein kinase subfamily of c-Jun kinases. *Nature* 369:156-160.
120. Gupta, S., T. Barrett, A. J. Whitmarsh, J. Cavanagh, H. K. Sluss, B. Derijard, and R. J. Davis. 1996. Selective interaction of JNK protein kinase isoforms with transcription factors. *EMBO J.* 15:2760-2770.
121. Teramoto, H., O. A. Coso, H. Miyata, T. Igishi, T. Miki, and J. S. Gutkind. 1996. Signaling from the small GTP-binding proteins Rac1 and Cdc42 to the c-Jun N-terminal kinase/stress-activated protein kinase pathway. A role for mixed lineage kinase 3/protein-tyrosine kinase 1, a novel member of the mixed lineage kinase family. *J.Biol.Chem.* 271:27225-27228.
122. Brown, J. L., L. Stowers, M. Baer, J. Trejo, S. Coughlin, and J. Chant. 1996. Human Ste20 homologue hPAK1 links GTPases to the JNK MAP kinase pathway. *Curr.Biol.* 6:598-605.
123. Bagrodia, S., B. Derijard, R. J. Davis, and R. A. Cerione. 1995. Cdc42 and PAK-mediated signaling leads to Jun kinase and p38 mitogen-activated protein kinase activation. *J.Biol.Chem.* 270:27995-27998.
124. Lee, J. C. and P. R. Young. 1996. Role of CSB/p38/RK stress response kinase in LPS and cytokine signaling mechanisms. *J.Leukoc.Biol.* 59:152-157.

125. Lee, J. C., J. T. Laydon, P. C. McDonnell, T. F. Gallagher, S. Kumar, D. Green, D. McNulty, M. J. Blumenthal, J. R. Heys, S. W. Landvatter, and . 1994. A protein kinase involved in the regulation of inflammatory cytokine biosynthesis. *Nature* 372:739-746.
126. Zarubin, T. and J. Han. 2005. Activation and signaling of the p38 MAP kinase pathway. *Cell Res.* 15:11-18.
127. Foey, A. D., S. L. Parry, L. M. Williams, M. Feldmann, B. M. Foxwell, and F. M. Brennan. 1998. Regulation of monocyte IL-10 synthesis by endogenous IL-1 and TNF-alpha: role of the p38 and p42/44 mitogen-activated protein kinases. *J.Immunol.* 160:920-928.
128. Ge, B., H. Gram, F. Di Padova, B. Huang, L. New, R. J. Ulevitch, Y. Luo, and J. Han. 2002. MAPKK-independent activation of p38alpha mediated by TAB1-dependent autophosphorylation of p38alpha. *Science* 295:1291-1294.
129. Derijard, B., J. Raingeaud, T. Barrett, I. H. Wu, J. Han, R. J. Ulevitch, and R. J. Davis. 1995. Independent human MAP-kinase signal transduction pathways defined by MEK and MKK isoforms. *Science* 267:682-685.
130. Raingeaud, J., A. J. Whitmarsh, T. Barrett, B. Derijard, and R. J. Davis. 1996. *Mol.Cell Biol.* 16:1247-1255.
131. Guan, Z., S. Y. Buckman, A. P. Pentland, D. J. Templeton, and A. R. Morrison. 1998. Induction of cyclooxygenase-2 by the activated MEKK1 --> SEK1/MKK4 -> p38 mitogen-activated protein kinase pathway. *J.Biol.Chem.* 273:12901-12908.
132. Rousset, F., E. Garcia, T. Defrance, C. Peronne, N. Vezzio, D. H. Hsu, R. Kastelein, K. W. Moore, and J. Banchereau. 1992. Interleukin 10 is a potent growth and differentiation factor for activated human B lymphocytes. *Proc.Natl.Acad.Sci.U.S.A* 89:1890-1893.
133. Del Prete, G., M. De Carli, F. Almerigogna, M. G. Giudizi, R. Biagiotti, and S. Romagnani. 1993. Human IL-10 is produced by both type 1 helper (Th1) and type 2 helper (Th2) T cell clones and inhibits their antigen-specific proliferation and cytokine production. *J.Immunol.* 150:353-360.
134. Daftarian, P. M., A. Kumar, M. Kryworuchko, and F. Diaz-Mitoma. 1996. IL-10 production is enhanced in human T cells by IL-12 and IL-6 and in monocytes by tumor necrosis factor-alpha. *J.Immunol.* 157:12-20.
135. Moore, K. W., M. R. de Waal, R. L. Coffman, and A. O'Garra. 2001. Interleukin-10 and the interleukin-10 receptor. *Annu.Rev.Immunol.* 19:683-765.
136. Pestka, S., C. D. Krause, D. Sarkar, M. R. Walter, Y. Shi, and P. B. Fisher. 2004. Interleukin-10 and related cytokines and receptors. *Annu.Rev.Immunol.* 22:929-979.

137. de Waal, M. R., J. Haanen, H. Spits, M. G. Roncarolo, V. A. te, C. Figdor, K. Johnson, R. Kastelein, H. Yssel, and J. E. de Vries. 1991. Interleukin 10 (IL-10) and viral IL-10 strongly reduce antigen-specific human T cell proliferation by diminishing the antigen-presenting capacity of monocytes via downregulation of class II major histocompatibility complex expression. *J.Exp.Med.* 174:915-924.
138. Fiorentino, D. F., A. Zlotnik, P. Vieira, T. R. Mosmann, M. Howard, K. W. Moore, and A. O'Garra. 1991. IL-10 acts on the antigen-presenting cell to inhibit cytokine production by Th1 cells. *J.Immunol.* 146:3444-3451.
139. Bogdan, C., Y. Vodovotz, and C. Nathan. 1991. Macrophage deactivation by interleukin 10. *J.Exp.Med.* 174:1549-1555.
140. Mocellin, S., M. C. Panelli, E. Wang, D. Nagorsen, and F. M. Marincola. 2003. The dual role of IL-10. *Trends Immunol.* 24:36-43.
141. Briere, F., C. Servet-Delprat, J. M. Bridon, J. M. Saint-Remy, and J. Banchereau. 1994. Human interleukin 10 induces naive surface immunoglobulin D+ (sIgD+) B cells to secrete IgG1 and IgG3. *J.Exp.Med.* 179:757-762.
142. Ishida, H., R. Hastings, J. Kearney, and M. Howard. 1992. Continuous anti-interleukin 10 antibody administration depletes mice of Ly-1 B cells but not conventional B cells. *J.Exp.Med.* 175:1213-1220.
143. Riley, J. K., K. Takeda, S. Akira, and R. D. Schreiber. 1999. Interleukin-10 receptor signaling through the JAK-STAT pathway. Requirement for two distinct receptor-derived signals for anti-inflammatory action. *J.Biol.Chem.* 274:16513-16521.
144. Weber-Nordt, R. M., J. K. Riley, A. C. Greenlund, K. W. Moore, J. E. Darnell, and R. D. Schreiber. 1996. Stat3 recruitment by two distinct ligand-induced, tyrosine-phosphorylated docking sites in the interleukin-10 receptor intracellular domain. *J.Biol.Chem.* 271:27954-27961.
145. Finbloom, D. S. and K. D. Winestock. 1995. IL-10 induces the tyrosine phosphorylation of tyk2 and Jak1 and the differential assembly of STAT1 alpha and STAT3 complexes in human T cells and monocytes. *J.Immunol.* 155:1079-1090.
146. O'Farrell, A. M., D. A. Parry, F. Zindy, M. F. Roussel, E. Lees, K. W. Moore, and A. L. Mui. 2000. Stat3-dependent induction of p19INK4D by IL-10 contributes to inhibition of macrophage proliferation. *J.Immunol.* 164:4607-4615.
147. O'Farrell, A. M., Y. Liu, K. W. Moore, and A. L. Mui. 1998. IL-10 inhibits macrophage activation and proliferation by distinct signaling mechanisms: evidence for Stat3-dependent and -independent pathways. *EMBO J.* 17:1006-1018.

148. Berlato, C., M. A. Cassatella, I. Kinjyo, L. Gatto, A. Yoshimura, and F. Bazzoni. 2002. Involvement of suppressor of cytokine signaling-3 as a mediator of the inhibitory effects of IL-10 on lipopolysaccharide-induced macrophage activation. *J.Immunol.* 168:6404-6411.
149. Ding, Y., D. Chen, A. Tarcsafalvi, R. Su, L. Qin, and J. S. Bromberg. 2003. Suppressor of cytokine signaling 1 inhibits IL-10-mediated immune responses. *J.Immunol.* 170:1383-1391.
150. Gatto, L., C. Berlato, V. Poli, S. Tininini, I. Kinjyo, A. Yoshimura, M. A. Cassatella, and F. Bazzoni. 2004. Analysis of SOCS-3 promoter responses to interferon gamma. *J.Biol.Chem.* 279:13746-13754.
151. Meraz, M. A., J. M. White, K. C. Sheehan, E. A. Bach, S. J. Rodig, A. S. Dighe, D. H. Kaplan, J. K. Riley, A. C. Greenlund, D. Campbell, K. Carver-Moore, R. N. DuBois, R. Clark, M. Aguet, and R. D. Schreiber. 1996. Targeted disruption of the Stat1 gene in mice reveals unexpected physiologic specificity in the JAK-STAT signaling pathway. *Cell* 84:431-442.
152. Rahimi, A. A., K. Gee, S. Mishra, W. Lim, and A. Kumar. 2005. STAT-1 mediates the stimulatory effect of IL-10 on CD14 expression in human monocytic cells. *J.Immunol.* 174:7823-7832.
153. Crawley, J. B., L. M. Williams, T. Mander, F. M. Brennan, and B. M. Foxwell. 1996. Interleukin-10 stimulation of phosphatidylinositol 3-kinase and p70 S6 kinase is required for the proliferative but not the antiinflammatory effects of the cytokine. *J.Biol.Chem.* 271:16357-16362.
154. Zhou, J. H., S. R. Broussard, K. Strle, G. G. Freund, R. W. Johnson, R. Dantzer, and K. W. Kelley. 2001. IL-10 inhibits apoptosis of promyeloid cells by activating insulin receptor substrate-2 and phosphatidylinositol 3'-kinase. *J.Immunol.* 167:4436-4442.
155. Burfoot, M. S., N. C. Rogers, D. Watling, J. M. Smith, S. Pons, G. Paonessaw, S. Pellegrini, M. F. White, and I. M. Kerr. 1997. Janus kinase-dependent activation of insulin receptor substrate 1 in response to interleukin-4, oncostatin M, and the interferons. *J.Biol.Chem.* 272:24183-24190.
156. Deane, J. A. and D. A. Fruman. 2004. Phosphoinositide 3-kinase: diverse roles in immune cell activation. *Annu.Rev.Immunol.* 22:563-598.
157. Pahan, K., M. Khan, and I. Singh. 2000. Interleukin-10 and interleukin-13 inhibit proinflammatory cytokine-induced ceramide production through the activation of phosphatidylinositol 3-kinase. *J.Neurochem.* 75:576-582.
158. Lee, T. S. and L. Y. Chau. 2002. Heme oxygenase-1 mediates the anti-inflammatory effect of interleukin-10 in mice. *Nat.Med.* 8:240-246.

159. Gee, K., W. Lim, W. Ma, D. Nandan, F. Diaz-Mitoma, M. Kozlowski, and A. Kumar. 2002. Differential regulation of CD44 expression by lipopolysaccharide (LPS) and TNF-alpha in human monocytic cells: distinct involvement of c-Jun N-terminal kinase in LPS-induced CD44 expression. *J.Immunol.* 169:5660-5672.
160. Zhao, J., G. J. Freeman, G. S. Gray, L. M. Nadler, and L. H. Glimcher. 1996. A cell type-specific enhancer in the human B7.1 gene regulated by NF-kappaB. *J.Exp.Med.* 183:777-789.
161. Fong, T. C., Y. Wu, and T. J. Kipps. 1996. Identification of a promoter element that regulates tissue-specific expression of the human CD80 (B7.1) gene. *J.Immunol.* 157:4442-4450.
162. Wakem, P., R. P. Burns, Jr., F. Ramirez, D. Zlotnick, B. Ferbel, C. G. Haidaris, and A. A. Gaspari. 2000. Allergens and irritants transcriptionally upregulate CD80 gene expression in human keratinocytes. *J.Invest Dermatol.* 114:1085-1092.
163. Selvakumar, A., P. C. White, and B. Dupont. 1993. Genomic organization of the mouse B-lymphocyte activation antigen B7. *Immunogenetics* 38:292-295.
164. Antonia, S. J., C. Finley, and T. Munoz-Antonia. 1996. Cloning and partial characterization of the mouse B7-1 promoter. *Immunogenetics* 43:234-237.
165. Jennings, R., T. Munoz-Antonia, Z. Zhu, R. Jackson, and S. Antonia. 1999. Identification of an enhancer element in the mouse B7-1 promoter. *Immunogenetics* 50:109-112.
166. Zhang, H., D. Haasch, K. B. Idler, and G. F. Okasinski. 1996. Isolation and promoter mapping of the gene encoding murine co-stimulatory factor B7-1. *Gene* 183:1-6.
167. Li, J., A. I. Colovai, R. Cortesini, and N. Suci-Foca. 2000. Cloning and functional characterization of the 5'-regulatory region of the human CD86 gene. *Hum.Immunol.* 61:486-498.
168. Liu, Z., S. Tugulea, R. Cortesini, and N. Suci-Foca. 1998. Specific suppression of T helper alloreactivity by allo-MHC class I-restricted CD8+. *Int.Immunol.* 10:775-783.
169. Liu, Z., S. Tugulea, R. Cortesini, S. Lederman, and N. Suci-Foca. 1999. Inhibition of CD40 signaling pathway in antigen presenting cells by T suppressor cells. *Hum.Immunol.* 60:568-574.
170. Li, J., Z. Liu, S. Jiang, R. Cortesini, S. Lederman, and N. Suci-Foca. 1999. T suppressor lymphocytes inhibit NF-kappa B-mediated transcription of CD86 gene in APC. *J.Immunol.* 163:6386-6392.

171. Weatherill, A. R., J. Y. Lee, L. Zhao, D. G. Lemay, H. S. Youn, and D. H. Hwang. 2005. Saturated and polyunsaturated fatty acids reciprocally modulate dendritic cell functions mediated through TLR4. *J.Immunol.* 174:5390-5397.
172. Dudley, D. T., L. Pang, S. J. Decker, A. J. Bridges, and A. R. Saltiel. 1995. A synthetic inhibitor of the mitogen-activated protein kinase cascade. *Proc.Natl.Acad.Sci.U.S.A* 92:7686-7689.
173. Bennett, B. L., D. T. Sasaki, B. W. Murray, E. C. O'Leary, S. T. Sakata, W. Xu, J. C. Leisten, A. Motiwala, S. Pierce, Y. Satoh, S. S. Bhagwat, A. M. Manning, and D. W. Anderson. 2001. SP600125, an anthrapyrazolone inhibitor of Jun N-terminal kinase. *Proc.Natl.Acad.Sci.U.S.A* 98:13681-13686.
174. Ma, W., W. Lim, K. Gee, S. Aucoin, D. Nandan, M. Kozlowski, F. Diaz-Mitoma, and A. Kumar. 2001. The p38 mitogen-activated kinase pathway regulates the human interleukin-10 promoter via the activation of Sp1 transcription factor in lipopolysaccharide-stimulated human macrophages. *J.Biol.Chem.* 276:13664-13674.
175. Kumar, A., J. B. Angel, S. Aucoin, W. D. Creery, M. P. Daftarian, D. W. Cameron, L. Filion, and F. Diaz-Mitoma. 1999. Dysregulation of B7.2 (CD86) expression on monocytes of HIV-infected individuals is associated with altered production of IL-2. *Clin.Exp.Immunol.* 117:84-91.
176. Linsley, P. S. and J. A. Ledbetter. 1993. The role of the CD28 receptor during T cell responses to antigen. *Annu.Rev.Immunol.* 11:191-212.
177. Sharpe, A. H. and G. J. Freeman. 2002. The B7-CD28 superfamily. *Nat.Rev.Immunol.* 2:116-126.
178. Fraser, J. D., B. A. Irving, G. R. Crabtree, and A. Weiss. 1991. Regulation of interleukin-2 gene enhancer activity by the T cell accessory molecule CD28. *Science* 251:313-316.
179. Wells, A. D., H. Gudmundsdottir, and L. A. Turka. 1997. Following the fate of individual T cells throughout activation and clonal expansion. Signals from T cell receptor and CD28 differentially regulate the induction and duration of a proliferative response. *J.Clin.Invest* 100:3173-3183.
180. Prilliman, K. R., E. E. Lemmens, G. Palioungas, T. G. Wolfe, J. P. Allison, A. H. Sharpe, and S. P. Schoenberger. 2002. Cutting edge: a crucial role for B7-CD28 in transmitting T help from APC to CTL. *J.Immunol.* 169:4094-4097.
181. Chang, T. T., C. Jabs, R. A. Sobel, V. K. Kuchroo, and A. H. Sharpe. 1999. Studies in B7-deficient mice reveal a critical role for B7 costimulation in both induction and effector phases of experimental autoimmune encephalomyelitis. *J.Exp.Med.* 190:733-740.

182. Guerder, S., J. Meyerhoff, and R. Flavell. 1994. The role of the T cell costimulator B7-1 in autoimmunity and the induction and maintenance of tolerance to peripheral antigen. *Immunity* 1:155-166.
183. Salomon, B. and J. A. Bluestone. 2001. Complexities of CD28/B7: CTLA-4 costimulatory pathways in autoimmunity and transplantation. *Annu.Rev.Immunol.* 19:225-252.
184. Gao, J. X., H. Zhang, X. F. Bai, J. Wen, X. Zheng, J. Liu, P. Zheng, and Y. Liu. 2002. Perinatal blockade of b7-1 and b7-2 inhibits clonal deletion of highly pathogenic autoreactive T cells. *J.Exp.Med.* 195:959-971.
185. Baskar, S., L. Glimcher, N. Nabavi, R. T. Jones, and S. Ostrand-Rosenberg. 1995. Major histocompatibility complex class II+B7-1+ tumor cells are potent vaccines for stimulating tumor rejection in tumor-bearing mice. *J.Exp.Med.* 181:619-629.
186. Hall, A. J., H. L. Vos, and R. M. Bertina. 1999. Lipopolysaccharide induction of tissue factor in THP-1 cells involves Jun protein phosphorylation and nuclear factor kappaB nuclear translocation. *J.Biol.Chem.* 274:376-383.
187. Liu, M. K., P. Herrera-Velit, R. W. Brownsey, and N. E. Reiner. 1994. CD14-dependent activation of protein kinase C and mitogen-activated protein kinases (p42 and p44) in human monocytes treated with bacterial lipopolysaccharide. *J.Immunol.* 153:2642-2652.
188. Shalom-Barak, T., J. Quach, and M. Lotz. 1998. Interleukin-17-induced gene expression in articular chondrocytes is associated with activation of mitogen-activated protein kinases and NF-kappaB. *J.Biol.Chem.* 273:27467-27473.
189. Lim, W., K. Gee, and S. K. A. Mishra. 2005. Regulation of B7.1 Co-stimulatory Molecule is Mediated by the Interferon Regulatory Factor-7 Through the Activation of c-Jun N-Terminal Kinase in Lipopolysaccharide-stimulated Human Monocytic Cells. *J.Immunol.*
190. Beyaert, R., A. Cuenda, W. Vanden Berghe, S. Plaisance, J. C. Lee, G. Haegeman, P. Cohen, and W. Fiers. 1996. The p38/RK mitogen-activated protein kinase pathway regulates interleukin-6 synthesis response to tumor necrosis factor. *EMBO J.* 15:1914-1923.
191. Hirasawa, N., Y. Sato, Y. Fujita, S. Mue, and K. Ohuchi. 1998. Inhibition by dexamethasone of antigen-induced c-Jun N-terminal kinase activation in rat basophilic leukemia cells. *J.Immunol.* 161:4939-4943.
192. Verheij, M., R. Bose, X. H. Lin, B. Yao, W. D. Jarvis, S. Grant, M. J. Birrer, E. Szabo, L. I. Zon, J. M. Kyriakis, A. Haimovitz-Friedman, Z. Fuks, and R. N. Kolesnick. 1996. Requirement for ceramide-initiated SAPK/JNK signalling in stress-induced apoptosis. *Nature* 380:75-79.

193. Zanke, B. W., K. Boudreau, E. Rubie, E. Winnett, L. A. Tibbles, L. Zon, J. Kyriakis, F. F. Liu, and J. R. Woodgett. 1996. The stress-activated protein kinase pathway mediates cell death following injury induced by cis-platinum, UV irradiation or heat. *Curr.Biol.* 6:606-613.
194. Whitmarsh, A. J., P. Shore, A. D. Sharrocks, and R. J. Davis. 1995. Integration of MAP kinase signal transduction pathways at the serum response element. *Science* 269:403-407.
195. Jonat, C., H. J. Rahmsdorf, K. K. Park, A. C. Cato, S. Gebel, H. Ponta, and P. Herrlich. 1990. Antitumor promotion and antiinflammation: down-modulation of AP-1 (Fos/Jun) activity by glucocorticoid hormone. *Cell* 62:1189-1204.
196. Schule, R., P. Rangarajan, S. Kliewer, L. J. Ransone, J. Bolado, N. Yang, I. M. Verma, and R. M. Evans. 1990. Functional antagonism between oncoprotein c-Jun and the glucocorticoid receptor. *Cell* 62:1217-1226.
197. Wright, S. D., R. A. Ramos, P. S. Tobias, R. J. Ulevitch, and J. C. Mathison. 1990. CD14, a receptor for complexes of lipopolysaccharide (LPS) and LPS binding protein. *Science* 249:1431-1433.
198. Takeuchi, O., K. Hoshino, and S. Akira. 2000. Cutting edge: TLR2-deficient and MyD88-deficient mice are highly susceptible to *Staphylococcus aureus* infection. *J.Immunol.* 165:5392-5396.
199. Thompson, C. B. 1995. Distinct roles for the costimulatory ligands B7-1 and B7-2 in T helper cell differentiation? *Cell* 81:979-982.
200. Yang, D., C. Tournier, M. Wusk, H. T. Lu, J. Xu, R. J. Davis, and R. A. Flavell. 1997. Targeted disruption of the MKK4 gene causes embryonic death, inhibition of c-Jun NH2-terminal kinase activation, and defects in AP-1 transcriptional activity. *Proc.Natl.Acad.Sci.U.S.A* 94:3004-3009.
201. Guha, M. and N. Mackman. 2001. LPS induction of gene expression in human monocytes. *Cell Signal.* 13:85-94.
202. Chow, C. W., S. Grinstein, and O. D. Rotstein. 1995. Signaling events in monocytes and macrophages. *New Horiz.* 3:342-351.
203. Yang, H., C. H. Lin, G. Ma, M. O. Baffi, and M. G. Wathélet. 2003. Interferon regulatory factor-7 synergizes with other transcription factors through multiple interactions with p300/CBP coactivators. *J.Biol.Chem.* 278:15495-15504.
204. Zhang, L. and J. S. Pagano. 2002. Structure and function of IRF-7. *J.Interferon Cytokine Res.* 22:95-101.

205. Wathélet, M. G., C. H. Lin, B. S. Parekh, L. V. Ronco, P. M. Howley, and T. Maniatis. 1998. Virus infection induces the assembly of coordinately activated transcription factors on the IFN-beta enhancer in vivo. *Mol. Cell* 1:507-518.
206. Taniguchi, T., K. Ogasawara, A. Takaoka, and N. Tanaka. 2001. IRF family of transcription factors as regulators of host defense. *Annu.Rev.Immunol.* 19:623-655.
207. Au, W. C., P. A. Moore, D. W. LaFleur, B. Tombal, and P. M. Pitha. 1998. Characterization of the interferon regulatory factor-7 and its potential role in the transcription activation of interferon A genes. *J.Biol.Chem.* 273:29210-29217.
208. Lu, R. and P. M. Pitha. 2001. Monocyte differentiation to macrophage requires interferon regulatory factor 7. *J.Biol.Chem.* 276:45491-45496.
209. Zhang, L. and J. S. Pagano. 2001. Interferon regulatory factor 7 mediates activation of Tap-2 by Epstein-Barr virus latent membrane protein 1. *J.Virol.* 75:341-350.
210. Lin, R., Y. Mamane, and J. Hiscott. 2000. Multiple regulatory domains control IRF-7 activity in response to virus infection. *J.Biol.Chem.* 275:34320-34327.
211. Smith, E. J., I. Marie, A. Prakash, A. Garcia-Sastre, and D. E. Levy. 2001. IRF3 and IRF7 phosphorylation in virus-infected cells does not require double-stranded RNA-dependent protein kinase R or Ikappa B kinase but is blocked by Vaccinia virus E3L protein. *J.Biol.Chem.* 276:8951-8957.
212. Reyes-Moreno, C., J. Girouard, R. Lapointe, A. Darveau, and W. Mourad. 2004. CD40/CD40 homodimers are required for CD40-induced phosphatidylinositol 3-kinase-dependent expression of B7.2 by human B lymphocytes. *J.Biol.Chem.* 279:7799-7806.
213. Yang, D. D., C. Y. Kuan, A. J. Whitmarsh, M. Rincon, T. S. Zheng, R. J. Davis, P. Rakic, and R. A. Flavell. 1997. Absence of excitotoxicity-induced apoptosis in the hippocampus of mice lacking the Jnk3 gene. *Nature* 389:865-870.
214. Yang, D. D., D. Conze, A. J. Whitmarsh, T. Barrett, R. J. Davis, M. Rincon, and R. A. Flavell. 1998. Differentiation of CD4+ T cells to Th1 cells requires MAP kinase JNK2. *Immunity* 9:575-585.
215. Dong, C., D. D. Yang, C. Tournier, A. J. Whitmarsh, J. Xu, R. J. Davis, and R. A. Flavell. 2000. JNK is required for effector T-cell function but not for T-cell activation. *Nature* 405:91-94.
216. Constant, S. L., C. Dong, D. D. Yang, M. Wusk, R. J. Davis, and R. A. Flavell. 2000. JNK1 is required for T cell-mediated immunity against Leishmania major infection. *J.Immunol.* 165:2671-2676.

217. Paust, S., L. Lu, N. McCarty, and H. Cantor. 2004. Engagement of B7 on effector T cells by regulatory T cells prevents autoimmune disease. *Proc.Natl.Acad.Sci.U.S.A* 101:10398-10403.
218. Barnes, B., B. Lubyova, and P. M. Pitha. 2002. On the role of IRF in host defense. *J.Interferon Cytokine Res.* 22:59-71.
219. Jacobs, A. T. and L. J. Ignarro. 2001. Lipopolysaccharide-induced expression of interferon-beta mediates the timing of inducible nitric-oxide synthase induction in RAW 264.7 macrophages. *J.Biol.Chem.* 276:47950-47957.
220. Gao, J. J., M. B. Filla, M. J. Fultz, S. N. Vogel, S. W. Russell, and W. J. Murphy. 1998. Autocrine/paracrine IFN- α mediates the lipopolysaccharide-induced activation of transcription factor Stat1 α in mouse macrophages: pivotal role of Stat1 α in induction of the inducible nitric oxide synthase gene. *J.Immunol.* 161:4803-4810.
221. Ma, W., K. Gee, W. Lim, K. Chambers, J. B. Angel, M. Kozlowski, and A. Kumar. 2004. Dexamethasone inhibits IL-12p40 production in lipopolysaccharide-stimulated human monocytic cells by down-regulating the activity of c-Jun N-terminal kinase, the activation protein-1, and NF-kappa B transcription factors. *J.Immunol.* 172:318-330.
222. Rincon, M., A. Whitmarsh, D. D. Yang, L. Weiss, B. Derijard, P. Jayaraj, R. J. Davis, and R. A. Flavell. 1998. The JNK pathway regulates the In vivo deletion of immature CD4(+)CD8(+) thymocytes. *J.Exp.Med.* 188:1817-1830.
223. Jaeschke, A., M. Rincon, B. Doran, J. Reilly, D. Neuberger, D. L. Greiner, L. D. Shultz, A. A. Rossini, R. A. Flavell, and R. J. Davis. 2005. Disruption of the Jnk2 (Mapk9) gene reduces destructive insulinitis and diabetes in a mouse model of type I diabetes. *Proc.Natl.Acad.Sci.U.S.A* 102:6931-6935.
224. Biron, C. A. and R. T. Gazzinelli. 1995. Effects of IL-12 on immune responses to microbial infections: a key mediator in regulating disease outcome. *Curr.Opin.Immunol.* 7:485-496.
225. Gately, M. K., L. M. Renzetti, J. Magram, A. S. Stern, L. Adorini, U. Gubler, and D. H. Presky. 1998. The interleukin-12/interleukin-12-receptor system: role in normal and pathologic immune responses. *Annu.Rev.Immunol.* 16:495-521.
226. Cooper, A. M., J. Magram, J. Ferrante, and I. M. Orme. 1997. Interleukin 12 (IL-12) is crucial to the development of protective immunity in mice intravenously infected with mycobacterium tuberculosis. *J.Exp.Med.* 186:39-45.
227. Manning, A. M. and R. J. Davis. 2003. Targeting JNK for therapeutic benefit: from junk to gold? *Nat.Rev.Drug Discov.* 2:554-565.

228. Guan, Q. H., D. S. Pei, Q. G. Zhang, Z. B. Hao, T. L. Xu, and G. Y. Zhang. 2005. The neuroprotective action of SP600125, a new inhibitor of JNK, on transient brain ischemia/reperfusion-induced neuronal death in rat hippocampal CA1 via nuclear and non-nuclear pathways. *Brain Res.* 1035:51-59.
229. Carboni, S., A. Hiver, C. Szyndralewicz, P. Gaillard, J. P. Gotteland, and P. A. Vitte. 2004. AS601245 (1,3-benzothiazol-2-yl (2-[[2-(3-pyridinyl) ethyl] amino]-4 pyrimidinyl) acetonitrile): a c-Jun NH2-terminal protein kinase inhibitor with neuroprotective properties. *J.Pharmacol.Exp.Ther.* 310:25-32.
230. Marderstein, E. L., B. Bucher, Z. Guo, X. Feng, K. Reid, and D. A. Geller. 2003. Protection of rat hepatocytes from apoptosis by inhibition of c-Jun N-terminal kinase. *Surgery* 134:280-284.
231. Ferrandi, C., R. Ballerio, P. Gaillard, C. Giachetti, S. Carboni, P. A. Vitte, J. P. Gotteland, and R. Cirillo. 2004. Inhibition of c-Jun N-terminal kinase decreases cardiomyocyte apoptosis and infarct size after myocardial ischemia and reperfusion in anaesthetized rats. *Br.J.Pharmacol.* 142:953-960.
232. Noguchi, H., Y. Nakai, S. Matsumoto, M. Kawaguchi, M. Ueda, T. Okitsu, Y. Iwanaga, Y. Yonekawa, H. Nagata, K. Minami, Y. Masui, S. Futaki, and K. Tanaka. 2005. Cell permeable peptide of JNK inhibitor prevents islet apoptosis immediately after isolation and improves islet graft function. *Am.J.Transplant* 5:1848-1855.
233. Kaneto, H., Y. Nakatani, T. Miyatsuka, D. Kawamori, T. A. Matsuoka, M. Matsuhisa, Y. Kajimoto, H. Ichijo, Y. Yamasaki, and M. Hori. 2004. Possible novel therapy for diabetes with cell-permeable JNK-inhibitory peptide. *Nat.Med.* 10:1128-1132.
234. Wanidworanun, C. and W. Strober. 1993. Predominant role of tumor necrosis factor-alpha in human monocyte IL-10 synthesis. *J.Immunol.* 151:6853-6861.
235. Platzer, C., C. Meisel, K. Vogt, M. Platzer, and H. D. Volk. 1995. Up-regulation of monocytic IL-10 by tumor necrosis factor-alpha and cAMP elevating drugs. *Int.Immunol.* 7:517-523.
236. Rincon, M., D. Conze, L. Weiss, N. L. Diehl, K. A. Fortner, D. Yang, R. A. Flavell, H. Enslin, A. Whitmarsh, and R. J. Davis. 2000. Conference highlight: do T cells care about the mitogen-activated protein kinase signalling pathways? *Immunol.Cell Biol.* 78:166-175.
237. Dong, C., D. D. Yang, M. Wusk, A. J. Whitmarsh, R. J. Davis, and R. A. Flavell. 1998. Defective T cell differentiation in the absence of Jnk1. *Science* 282:2092-2095.

238. Tournier, C., A. J. Whitmarsh, J. Cavanagh, T. Barrett, and R. J. Davis. 1997. Mitogen-activated protein kinase kinase 7 is an activator of the c-Jun NH2-terminal kinase. *Proc.Natl.Acad.Sci.U.S.A* 94:7337-7342.

Wilfred Tan Lim
#5 - 1678 Russell Road
Ottawa, Ontario, Canada
K1G 0M8
(613) 733 7544
wlim092@aix1.uottawa.ca

EDUCATION

*September 1999
to current* University of Ottawa
Ph.D. in Microbiology and Immunology

May 1997 University of British Columbia
B.Sc. in Biochemistry

EMPLOYMENT HISTORY

*January 2001
to current* University of Ottawa
Department of Biochemistry, Microbiology, and Immunology
Title: Biochemistry Laboratory Teaching Assistant
Proctor examiner

*February 1998
to August 1999* Children's Hospital of Eastern Ontario Research Institute
Division of Infectious Diseases and Virology (Dr. Ashok Kumar)
401 Smyth Road, Ottawa, ON K1H 8L1
Title: Research Assistant
Duties: Co-stimulatory molecules in HIV immuno-pathogenesis

*May 1997
to December 1997* Vancouver Hospital and Health Sciences Centre
Department of Medicine
Division of Infectious Diseases (Dr. Yossef Av-Gay)
Room 452, D Floor, 2733 Heather Street
Vancouver, BC V5Z 3J5
Title: Research Assistant 2
Duties: Laboratory Supervisor
Role of cholesterol oxidase in *M. tuberculosis* pathogenicity

*November 1995
to April 1997* University of British Columbia
Department of Microbiology (Dr. Julian Davies)
Title: Research Assistant
Duties: Cloning and sequencing of cholesterol oxidase gene from *M. tuberculosis*

PUBLICATIONS

1. **Lim W.**, Gee K., and Kumar A.: Role of c-Jun N-Terminal Kinase in the Molecular Regulation of the Costimulatory Molecule B7.1 in Lipopolysaccharide-Stimulated Human Monocytic Cells. *Journal of Immunology* 2005 Nov 1;175(9):5690-700.
2. Akbar A., Gee K., **Lim W.**, Mishra S., and Kumar A.: PI-3 kinase activated Stat-1 mediates the stimulatory effect of IL-10 on CD14 expression in human monocytic cells. *Journal of Immunology* 2005 Jun;174(12):7823-32.
3. Creery D., Weiss W., **Lim WT**, Aziz Z, Angel JB., and Kumar A.: Down-regulation of CXCR-4 and CCR-5 Expression by Interferon- γ is Associated with Inhibition of Chemotaxis and HIV Replication But Not HIV Entry into Human Monocytes. *Journal of Clinical Experimental Immunology* 2004 July;137(1):156-65.
4. Ma W., Gee K., **Lim W.**, Chambers K., Angel JB., Kozlowski M., and Kumar A.: Dexamethasone Inhibits IL-12p40 Production in LPS-Stimulated Human Monocytic Cells by Down-regulating the Activity of c-Jun-N-Terminal Kinase, the Activation Protein-1 and NF κ B Transcription Factors. *Journal of Immunology* 2004 Jan 1;172(1)318-30.
5. Hyde B., Turgonyi E., Kumar A., **Lim W.**, Larocque L., and Diaz-Mitoma F.: Clinical Improvement in Chronic Fatigue Syndrome is Associated with Enhanced Natural Killer Cell-Mediated Cytotoxicity: The Results of a Pilot Study with Isoprinosine. *Journal of Chronic Fatigue Syndrome* 2003;11(2):71-95
6. Gee K., **Lim W.**, Ma W., Nandan D., Diaz-Mitoma F., Kozlowski M., and Kumar A.: Differential Regulation of CD44 Expression by Lipopolysaccharide and Tumor Necrosis Factor- α in Human Monocytic Cells: Distinct Involvement of c-Jun-N-Terminal Kinase in LPS-Induced CD44 Expression. *Journal of Immunology* 2002 Nov 15;169(10):5660-72.
7. **Lim W.**, Ma W., Gee K., Aucoin S., Nandan D., Diaz-Mitoma F., Kozlowski M., and Kumar A.: Distinct role of p38 and c-Jun N-Terminal Kinases in IL-10-Dependent and IL-10-Independent Regulation of the Costimulatory Molecule B7.2 in Lipopolysaccharide-Stimulated Human Monocytic Cells. *Journal of Immunology* 2002 Feb 15;168(4):1759-69.
8. Parato KG, Kumar A, Badley AD, Sanchez-Dardon JL, Chambers KA, Young CD, **Lim W**, Kravcik S, Cameron DW, and Angel JB: Normalization of natural killer cell function and phenotype with effective anti-HIV therapy and the role of IL-10. *AIDS* 2002 Jun 14;16(9):1251-6.
9. Ma W., **Lim W.**, Gee K., Aucoin S., Nandan D., Kozlowski M., Diaz-Mitoma F., and Kumar A.: The p38 Mitogen-Activated Kinase Pathway Regulates the Human IL-10 Promoter via the Activation of Sp1 Transcription Factor in Lipopolysaccharide-Stimulated Human Macrophages. *Journal of Biological Chemistry* 2001 Apr 27;276(17):13644-74.

PATENTS

1. Av-Gay Y., **Lim W.**, Davies J.E.: Cholesterol Oxidase from *M. tuberculosis*. A novel bacterial enzyme. United States provisional patent application under 37 CFR 1.53(b)(2). Filed on July 11, 1997. Reference 07244/014001

AWARDS AND SCHOLARSHIPS

2003/2004 and 2004/2005	Ontario Graduate Scholarship
2003 and 2004	University of Ottawa Faculty of Graduate and Postdoctoral Studies Travel Grant
2001/2002 and 2002/2003	Ontario HIV Treatment Network Student Scholarship
2001/2005	University of Ottawa Excellence Scholarship
2000 and 2001	Dr. James J. Wiley Scholarship (OSOTF)
1998	BC Biotech First Job in Science and Technology Funding

CONFERENCE PRESENTATIONS

Experimental Biology

April 17-21, 2004

Washington, DC

Dexamethasone inhibits IL-12p40 production in LPS-stimulated human monocytic cells by down-regulating the activity of c-Jun-N-terminal kinase, the activation protein-1 and NFκB transcription factors. (Poster Presentation #A268 337.21)

Federation of Clinical Immunology Societies 3rd Annual Meeting

May 15-19, 2003

Paris, France

Differential Regulation of CD44 Expression by LPS and TNF-α in Human Monocytic Cells: Distinct Involvement of c-Jun N-Terminal Kinase in LPS-Induced CD44 Expression. (Poster Presentation #495)

4th Ontario HIV Treatment Network Research Day

From the Past: Looking to Future Successes

November 9 & 10, 2001

Toronto, Ontario

The Regulation of CXCR4 and CCR5 Expression on Human Monocytes by IFN-γ: Functional Implications on Cell Migration and HIV Infection. (Poster Presentation)