

Clitic combinations in Spanish: Syntax, processing and acquisition

Anahí Alba de la Fuente

Thesis submitted to the
Faculty of Graduate and Postdoctoral Studies
In partial fulfillment of the requirements
For the PhD degree in Spanish – Hispanic Linguistics

Department of Modern Languages and Literatures
Faculty of Arts
University of Ottawa

© Anahí Alba de la Fuente, Ottawa, Canada, 2012

ABSTRACT

The study of clitic clusters and the restrictions that surface when two or more clitics are combined have long intrigued linguists and, as such, clitic phenomena are at the core of an ever-growing body of research in linguistic theory. However, three aspects remain largely unexplored when it comes to clitic cluster constraints, namely the evolution of these restrictions through time, the perception and processing of different clitic combinations, both acceptable and unacceptable, by native speakers and the acquisition of such combinations by non-native speakers.

This dissertation, which focuses on 1st and 2nd person clitic clusters in Spanish, aims to shed new light on clitic phenomena with a new analysis and new data from all these perspectives. Specifically, I study the effects that case and marked features have on Spanish clitic combinations, both synchronically and diachronically. In addition, I explore the effects of clitic combination restrictions in language processing and analyze the learnability issues derived from such restrictions in three groups of speakers of Spanish as a second language whose L1s are English, French and Romanian, respectively. At a particular level, this dissertation is a study of clitic cluster constraints from different perspectives, both traditional and new, namely linguistic theory, diachrony, language processing and language acquisition. At a general level, it constitutes an attempt to explore the ways in which linguistic theory can guide applied research and, conversely, the ways in which experimental data may contribute to linguistic theory.

TABLE OF CONTENTS

ABSTRACT.....	ii
LIST OF TABLES	vi
LIST OF FIGURES.....	vii
ACKNOWLEDGMENTS.....	ix
0. INTRODUCTION.....	1
1. CLITICS, COMBINATIONS, RESTRICTIONS	6
1.1 ON THE NATURE AND STRUCTURE OF CLITICS	6
1.2. CLITIC RESTRICTIONS	13
1.2.1. MORPHOLOGICAL APPROACHES.....	14
1.2.2. SYNTACTIC APPROACHES.....	28
1.3. CASE, FEATURES AND HIERARCHIES	42
2. ACCOUNTING FOR CLITIC RESTRICTIONS IN ROMANCE.....	45
2.1. TOWARDS A UNIFIED ACCOUNT OF CLITIC RESTRICTIONS IN ROMANCE	46
2.2. A FEATURE MARKEDNESS CONSTRAINT	51
2.3. EVIDENCE FROM MODERN SPANISH	62
2.4. EVIDENCE FROM OTHER ROMANCE LANGUAGES	65
2.4.1. ROMANIAN	65
2.4.2. ITALIAN	68
2.4.3. CATALAN	71
2.5. FINAL REMARKS ON THE FMC AND INTERIM SUMMARY	73
3. THE FMC IN PREVIOUS STAGES OF SPANISH	75
3.1. A BRIEF OVERVIEW OF CLITICS IN OLD SPANISH	77
3.1.1 THE DEVELOPMENT OF THE SPANISH PRONOUN PARADIGM: FROM LATIN TO SPANISH.....	78
3.1.2. CLITIC POSITION IN THE SENTENCE.....	80
3.1.3. THE SYNTACTIC STATUS OF CLITICS IN OLD AND MODERN SPANISH.....	83
3.2 A DIACHRONIC ANALYSIS OF SPANISH CLITIC CLUSTERS	86
3.2.1 METHODOLOGY	88
3.2.2. RESULTS	89
3.3. CONCLUSIONS FROM THE DIACHRONIC DATA.....	112
4. GRAMMATICAL AND PROCESSING STATUS OF CLITIC CLUSTERS IN NATIVE SPANISH.....	115

4.1. SCALED GRAMMATICALITY JUDGMENT TASK	119
4.1.1 RESEARCH QUESTIONS.....	122
4.1.2 HYPOTHESES	122
4.1.3 EXPERIMENTAL DESIGN AND MATERIALS	122
4.1.4 PROCEDURE.....	128
4.1.5 PARTICIPANTS.....	129
4.1.6 RESULTS AND DISCUSSION	129
4.1.7 CONCLUSIONS FROM THE GRAMMATICALITY JUDGMENT TASK.....	145
4.2. ON-LINE SELF-PACED READING TASK	148
4.2.1 RESEARCH QUESTIONS.....	152
4.2.2 HYPOTHESES	152
4.2.3 EXPERIMENTAL DESIGN AND MATERIALS	153
4.2.4 PROCEDURE.....	158
4.2.5 PARTICIPANTS.....	159
4.2.6 RESULTS AND DISCUSSION	159
4.2.7 CONCLUSIONS FROM THE ON-LINE TASK.....	167
4.3. GENERAL CONCLUSIONS FROM THE NATIVE DATA	168
5. SECOND LANGUAGE ACQUISITION OF CLITIC RESTRICTIONS: REPRESENTATION, PROCESSING AND LEARNABILITY.....	171
5.1. SCALED GRAMMATICALITY JUDGMENT TASK	178
5.1.1. RESEARCH QUESTIONS.....	178
5.1.2. HYPOTHESES	179
5.1.3. EXPERIMENTAL DESIGN, MATERIALS AND PROCEDURE.....	180
5.1.4. RESULTS AND DISCUSSION	183
5.1.5. CONCLUSIONS FROM THE GRAMMATICALITY JUDGMENT TASK.....	211
5.2. ON-LINE SELF-PACED READING TASK	215
5.2.1. RESEARCH QUESTIONS.....	216
5.2.2. HYPOTHESES	217
5.2.3. EXPERIMENTAL DESIGN, MATERIALS AND PROCEDURE.....	218
5.2.4. RESULTS AND DISCUSSION	220
5.2.5. CONCLUSIONS FROM THE ON-LINE TASK.....	237
5.3. GENERAL CONCLUSIONS FROM THE NON-NATIVE DATA	240
6. CONCLUSIONS AND FURTHER RESEARCH	243

REFERENCES..... 250
APPENDIX A 263
APPENDIX B 264
APPENDIX C 269

LIST OF TABLES

Table 2.1. Accusative and dative clitics in Romanian and Spanish.....	67
Table 2.2. Distribution of 1 st and 2 nd person clitic clusters in Italian.....	69
Table 3.1. Spanish pronominal system [adapted from Penny 2002:133].....	79
Table 4.1. Acceptability judgment task results	120
Table 4.2. Scaled grammaticality judgment task item distribution	123
Table 4.3. Total mean ratings (experimental items)	130
Table 4.4. Total ratings from the native group by structure type	133
Table 4.5. Overall results for the NON-REFL and REFL conditions.....	137
Table 4.6. Distribution of responses across clusters.....	140
Table 4.7. Sample low rater (participant 101).....	143
Table 4.8. Sample high rater (participant 118)	143
Table 4.9. Average ratings for the REFL conditions per participant (left) and average overall ratings per participant (right) in ascending order	143
Table 4.10. On-line self-paced reading task item distribution	154
Table 5.1. Total mean ratings from the English group (experimental items)	184
Table 5.2. Total ratings from the English group by structure type.....	185
Table 5.3. English group results for the NON-REFL and REFL conditions	187
Table 5.4. Total mean ratings from the French group (experimental items)	192
Table 5.5. Total ratings from the French group by structure type.....	193
Table 5.6. French group results for the NON-REFL and REFL conditions.....	195
Table 5.7. Total mean ratings from the Romanian group (experimental items) ..	199
Table 5.8. Total ratings from the Romanian group by structure type.....	200
Table 5.9. Romanian group results for the NON-REFL and REFL conditions	201
Table 5.10. GJ task participant information – All groups	204
Table 5.11. Total mean ratings from all groups (experimental items).....	205
Table 5.12. Overall results for the ACC-NAD condition for all groups.....	207
Table 5.13. Overall results for the DAT-NAD condition for all groups	207
Table 5.14. Overall results for the REFL-NAD condition for all groups	207
Table 5.15. Overall results for the REFL-DAT condition for all groups.....	207
Table 5.16. Non-reflexive conditions grouped.....	209
Table 5.17. Reflexive conditions grouped	210
Table 5.18. Online task participant information – All groups	231

LIST OF FIGURES

Figure 4.1. Total average results from the native group by cluster type.....	130
Figure 4.2. Total average results from the native group by structure type.....	133
Figure 4.3. Average native group results for the NON-REFL and the REFL structures	138
Figure 4.4. Distribution of responses from the native group across cluster types	141
Figure 4.5. Native group overall results – grouped.....	161
Figure 4.6. REFL-DAT and REFL-NAD grouped (3 conditions).....	162
Figure 4.7. Native group overall results – by condition	164
Figure 4.8. REFL-DAT and REFL-NAD (5 conditions)	165
Figure 5.1. Total average results from the English group by cluster type	184
Figure 5.2. Total average results from the English group by structure type.....	186
Figure 5.3. Average English group results for the NON-REFL and the REFL structures	188
Figure 5.4. Distribution of responses from the English group across cluster types	189
Figure 5.5. Total average results from the French group by cluster type	192
Figure 5.6. Total average results from the French group by structure type	194
Figure 5.7. Average French group results for the NON-REFL and the REFL structures	195
Figure 5.8. Distribution of responses from the French group across cluster types	197
Figure 5.9. Total average results from the Romanian group by cluster type	199
Figure 5.10. Total average results from the Romanian group by structure type..	201
Figure 5.11. Average Romanian group results for the NON-REFL and the REFL structures	202
Figure 5.12. Distribution of responses from the Romanian group across cluster types	203
Figure 5.13. Total average results from all groups by cluster type.....	205
Figure 5.14. Average results for the ACC-NAD structure for all groups	208
Figure 5.15. Average results for the DAT-NAD structure for all groups	208
Figure 5.16. Average results for the REFL-NAD structure for all groups.....	208
Figure 5.17. Average results for the REFL-DAT structure for all groups	208

Figure 5.18. Average results for the non-reflexive conditions for all groups	210
Figure 5.19. Average results for the non-reflexive conditions for all groups.....	210
Figure 5.20. Totals grouped (3 conditions), English group	222
Figure 5.21. REFL-DAT and REFL-NAD grouped (3 conditions), English group.	223
Figure 5.22. Totals grouped (3 conditions), French group	226
Figure 5.23. REFL-DAT and REFL-NAD grouped (3 conditions), French group..	227
Figure 5.24. Totals grouped (3 conditions), Romanian group	229
Figure 5.25. REFL-DAT and REFL-NAD grouped (3 conditions), Romanian group	230
Figure 5.26. Totals all groups, Grammatical, Ungrammatical and *Syntactic conditions.	232
Figure 5.27. REFL-DAT structure all groups, Grammatical, Ungrammatical and *Syntactic conditions.	233
Figure 5.28. REFL-NAD structure all groups, Grammatical, Ungrammatical and *Syntactic conditions.	234

ACKNOWLEDGMENTS

I would never have been able to complete this dissertation without the help and support of quite a few people, so it is only fair that I devote a few lines here to express my gratitude to them.

Juana M. Licerias, who is so much more than a supervisor. A mentor, a colleague, a friend. Her industriousness and overwhelming generosity in every aspect of her life are both inspiring and humbling. She is so full of life and energy, it's contagious.

Raquel Fernández Fuertes, who set it all in motion. Thanks to her I am here now. I owe her so much more than I can say.

Juana and Raquel always go above and beyond what anyone could expect from them and I cannot thank them enough for everything they have done for me during these years.

María Luisa Rivero, to whom I owe the topic of this dissertation. She has been of great help throughout the years and consistently provided me with invaluable and timely feedback and assistance. She is a true professional role model.

Laura Sabourin, Andrés Salanova and Elena Valenzuela were all extremely supportive and I am very grateful to them for their encouragement, for the interest they took in my dissertation and for agreeing to be part of the examining committee.

María Cristina Cuervo was amazingly generous as an external examiner and provided me with plenty of insightful comments, suggestions and advice regarding my research.

My deepest gratitude goes to the 195 persons who volunteered to participate in the two experiments reported in this dissertation. I am also forever grateful to the institutions that opened their doors to me so that I could find participants for my “pronoun study”—The University of Valladolid, Instituto Cervantes of London, Instituto Cervantes of Paris, The University of Bucharest and Spiru Haret University— and to all the amazing people that helped me so much during the data collection. Many thanks to Pablo Martínez-Gila, whose help was truly invaluable, Ana Álvarez and the instructors at Instituto Cervantes of both in London and Paris. Many, many thanks as well to Ioana Winnicki, Sanda Ripeanu and Ileana Scipione for their incredible assistance and support during the “Romanian leg of the tour”. So much help... with such short notice!

I thank Daiana Dumbravescu from the bottom of my heart for her assistance and, just as importantly, for her kindness and wonderful hospitality. I would have not been able to do it without her support in Bucharest.

Special thanks to all my friends and colleagues at the LAR-LAB, who have taught me so much about linguistics, team work, dedication and, most importantly, about life. The “veterans” Cristina Martínez-Sanz, Rocio Pérez-Tattam, Diana Carter and Cristina Senn, and, of course, the current members (Raquel Llama, Nefalí Martín-Plaza, Nelson Méndez, Rachel Klassen, Elisa Acevedo, Luz Patricia López-Morelos, Irina Goundareva and Kristina Borg) who keep the spirit alive!

A great many thanks to Lia Walsh, for all her help in the final stages of writing the dissertation.

Big thanks to Karla and Gerardo for making this period of my life so much more fun and meaningful.

Julie and Karolina, with whom I shared the first (wonderful) moments of my Canadian adventure: My friends, it looks like it all did work out... eventually.

Danny, of course, thank you for so many things... If I had to write them all, the acknowledgments section would be longer than the dissertation itself, so I will just leave it at that.

My parents and my brother, far away but always near. Their love and unconditional support mean everything to me. They are a relentless source of motivation... and I love them to pieces.

To all of you, all I can say is thank you for making it all worthwhile, every step of the way.

This dissertation is dedicated to Danny, my parents and my brother.

0. INTRODUCTION

Clitics and clitic combinations have been subject to a great deal of research. However, the restrictions that arise when clitics are combined constitute a puzzle that continues to intrigue and challenge linguists. Furthermore, these constraints have often been associated with agreement restrictions found in a wide number of languages. Thus, in order to shed light on why and how these restrictions occur, as well as the repair strategies used by different languages, clitic constraints and agreement restrictions in general have been widely explored in recent years (Bonet 1991, 1994; Sigurðsson 2004; Nichols 2001; Haspelmath 2004; Anagnostopoulou 2003, 2005; Bianchi 2006; Adger and Harbour 2007; to name only a few).

These issues have attracted significant attention but, to this moment, the main body of research remains within the field of linguistic theory. The present study aims to contribute to the ongoing discussion of clitic and agreement restrictions by exploring a new path of research that includes both theoretical accounts and experimental data. Specifically, I analyze the ways in which linguistic theory can guide experimental research and, conversely, I explore how data from

different sources may shed new light on these theoretical issues and help further understand clitic cluster constraints and their motivations.

Many analyses have been proposed to account for the combinatorial possibilities of clitics, including linear ordering templates (Perlmutter 1971), syntactic accounts (Anagnostopoulou 2003, 2005; Ormazabal and Romero 2007; Adger and Harbour 2007), morphologic accounts (Bonet 1991; Rivero 2008; Heap 1998, 2005) and Optimality Theory accounts (Grimshaw 1997, 2001; Legendre 2000a, 2000b), among others. At the same time, a number of factors have been argued to be responsible for the restrictions that surface when two clitics are combined. Among these factors, the notions of hierarchy and feature markedness are of particular interest. Along these lines, this dissertation focuses on the effects that marked features have on clitic combinations, with special attention to case, person and, crucially, number, which has recently begun to receive more attention by researchers (Anagnostopoulou 2005; Rivero 2008; Nevins & Săvescu 2010).

Even though this study deals mainly with Spanish, novel data from Catalan and Romanian are also presented and discussed. Additionally, I explore new paths of investigation and analyze the evolution of 1st and 2nd clitic clusters in Spanish using the Diachronic Corpus of Spanish (CORDE) by the Real Academia Española.

In addition, I provide experimental data from native and non-native speakers of Spanish and analyze the grammatical and processing status of these clusters both in Spanish L1 and L2.

In sum, the ensemble of this study constitutes an attempt to present a comprehensive, multidimensional view of Spanish clitic restrictions, which, to my knowledge, has not been provided so far, and, ultimately, the presentation of these novel data and analyses, which may be of interest to scholars doing research in a

number of fields, namely linguistic theory, second language acquisition, and language processing, aims to contribute to a better understanding of clitic phenomena and agreement restrictions in general.

The dissertation is structured as follows:

Chapter 1 introduces a number of relevant studies dealing with clitics, clitic combinations and restrictions, notably the Person Case Constraint, as first proposed by Bonet (1991), proposals by Anagnostopoulou (2005) and Rivero (2008), both of which deal with 1st/2nd person clitic combinations, and Heap's (2005) Least Leafy to the Left constraint, which addresses the effects of feature markedness in the linear ordering of clitics.

Chapter 2 presents a new proposal, the Feature Markedness Constraint (FMC), based on the fact that there is an asymmetry with respect to the combination of singular and plural clitics in Spanish. This proposal assumes that case and feature markedness are responsible for the combinatorial patterns of object clitics in Romance languages. Chapter 2 also includes further evidence for the FMC in Modern Spanish and a discussion of novel data from Catalan, Romanian and Italian.

Chapter 3 presents a diachronic study of 1st/2nd person restrictions in previous stages of Spanish, which covers an analysis of such restrictions in stages in which Spanish clitics showed different properties and, in fact, were considered to belong to a different category than present day clitics (Rivero 1986, 1997; Fontana 1993, 1994, 1997). The results of the study demonstrate that, in general, the clitic combinatorial restrictions derived from the FMC are active in Modern Spanish as well as in previous stages of the language.

Chapters 4 and 5 incorporate language processing and learnability and explore the general questions of 1) how these restrictions are processed by both native and non-native speakers of Spanish, 2) whether such restrictions are learnable and 3) to what extent non-native speakers will be influenced by their L1 when confronted with clitic combinations in their L2. In order to explore these issues, I present two experiments: a scaled grammaticality judgment task and an on-line word-by-word self-paced reading task, which were administered to one group of native speakers of Peninsular Spanish and three groups of advanced non-native speakers of Spanish whose L1s were English, French and Romanian, respectively.

In Chapter 4, I report the results of the two experiments by the native group and provide an analysis of their mental representation of clitic cluster constraints, as well as the processing differences between clitic cluster constraints and purely syntactic ungrammaticalities (i.e. verb-agreement errors).

In Chapter 5, I report the results of the two experiments by the non-native groups and compare them to the native data in order to assess the learnability of these restrictions, as well as the influence from the L1 when it comes to judging and processing these constructions.

The results of the grammaticality judgment (GJ) task, both from native and non-native speakers, reveal a very strong preference for clusters that contain a reflexive. These results highlight the importance of reflexivity in the acceptance and rejection patterns of these constructions, which is an aspect that has not been explored in the available literature.

The results of the self-paced reading task suggest that, in the case of the native group, FMC violations are processed differently than ungrammaticalities such

as an agreement mismatch between a reflexive clitic and its antecedent. In turn, the results of the non-native groups suggest general processing difficulties with respect to both acceptable and unacceptable clitic clusters.

Finally, Chapter 6 provides a recapitulation of all the novel data and the general conclusions that can be extracted by bringing together theoretical analysis and experimental data from both native and non-native speakers.

1. CLITICS, COMBINATIONS, RESTRICTIONS

1.1 ON THE NATURE AND STRUCTURE OF CLITICS

Clitics have attracted a great deal of attention in the linguistic literature and they are at the core of an ever-growing body of research in areas such as phonology, morphology and syntax. This chapter presents an overview of a number of crucial aspects in the study of clitics, namely, their nature and structure, their combinatorial possibilities and the restrictions that surface when two clitics are combined.

On the nature of clitics

Clitics display a rather heterogeneous array of morphological and syntactic properties and, consequently, they are at the centre of numerous debates.¹ One of these arguments deals with the nature of clitics. Specifically, much discussion has

¹ As mentioned above, clitics have also been widely discussed in phonology. In particular, their prosodic structure has been subject to great debate. This dissertation, however, will focus on the morphological and syntactic aspects of clitic phenomena and issues such as the prosodic structure of clitics will not be discussed. For further information, studies dealing with clitics from a phonological perspective include: Nespor and Vogel (1986), Hayes (1989), Booij (1996), Selkirk (1995), Kleinhenz (1998) and Hall (1999); among others.

revolved around the issue of whether they may be classified as “words”, as “affixes” or whether they form a separate category.

Zwicky (1977) explains that in almost every language there are a number of morphemes which can neither be clearly classified as independent words, nor as affixes. These morphemes, however, are not a homogeneous category and, as such, he introduces the distinction between simple clitics, special clitics and affixes.

Simple clitics are phonologically reduced variants of full forms which “occur in the same positions in sentences as the corresponding full forms” (Zwicky and Pullum 1985:503). Examples of simple clitics include the contractions of *be* and *have* in English (e.g. *She is very nice / She's very nice*).

Affixes, on the other hand, are morphemes which are always bound and unaccented and do not have a corresponding full form. Plural morphemes in nouns constitute an example of affix (e.g. *car / cars*).

Finally, special clitics are unstressed forms that act as variants of stressed forms. Romance weak pronouns are examples of this category (e.g. *Je la connais*, ‘I know her’).

Zwicky and Pullum (1983) and (Zwicky 1985) propose a number of tests in order to determine whether an element may be classified as a “word”, an “affix”, or a “clitic”. These tests –the so-called “Zwicky criteria”–, however, are stated in terms of tendencies (Zwicky 1985:285) rather than clear-cut distinctions, and not all clitics can be easily classified in a given category. This difficulty in categorizing certain clitics is partly due to the fact that a single element may shift from one category to another and, consequently, independent words may eventually become

clitics.² In this respect, Zwicky (1977) argues that “special clitics are often the remnants of an earlier system of simple clitics” (Zwicky 1977:6).³

An alternative analysis is offered by Cardinaletti and Starke (1999) who also divide pronouns into three classes: strong pronouns, weak pronouns and clitic pronouns. However, instead of stating the differences between classes in terms of preference, Cardinaletti and Starke (1999) offer a set of morphological and syntactic criteria in order to determine the class to which an element belongs. Under this analysis, weak pronouns and clitics, which roughly correspond to Zwicky’s simple clitics and special clitics respectively, are classified as being “deficient pronouns”. More specifically, the authors explain that clitics are the most structurally deficient of all three classes since the “clitic” class is deficient with respect to the “weak pronoun” class, which is, in turn, deficient with respect to the “strong pronoun” class.

Cardinaletti and Starke argue against a two-way distinction, such as “strong pronouns” vs. “weak pronouns” because they understand that it is descriptively insufficient and defend that “pronominal systems divide into three distinct distributional patterns” (p. 165). However, the idea of having a threefold system, together with the fact that the line between clitic types is not always clear, has been criticized for reasons of economy and it has led several authors to attempt analyses of clitics that classify clitics either as words, or as affixes (Gerlach and Grijzenhout 2000:8). Thus, Monachesi (2000) argues that Romanian auxiliaries

² This has been argued to be the case for Romance languages such as French and Spanish, whose clitics have evolved from simple clitics in previous stages to special clitics in present-day language. The reader is referred to Chapter 3 of this dissertation for further details on the historical evolution of Spanish clitics.

³ In addition to the historical evolution of French and Spanish, Zwicky refers to Hale’s (1973) discussion of the pronominal system of Walbiri, an Australian language.

and the negation *nu* are words, rather than clitics, and Ortmann and Popescu (2000) defend that the Romanian article is an affix.

With respect to Spanish, it has been argued that its clitics are, in fact, verbal affixes which correspond to inflectional object agreement markers (Rivero 1986, Fontana 1993, Fernández Soriano 1999, among others)⁴. Furthermore, this view of clitics as phrasal affixes, also suggested by Anderson (1992), is now widely accepted in the literature (Gerlach and Grijzenhout 2000).

On the structure of clitics

A further aspect that has been subject to great debate is the syntactic status of clitics in the grammatical structure. In this respect, there are two main competing analyses: the movement hypothesis (Kayne 1975, Rizzi 1986) and the base-generation hypothesis (Strozer 1976, Rivas 1977, Jaeggli 1982, Borer 1984).

The movement hypothesis defends that object clitics are generated in the canonical position of verb arguments and then move out of their XP position and attach to the verb by left adjunction. This account has been argued to be problematic when it comes to accounting for phenomena such as clitic doubling, where the dative appears both as a clitic and as an argument (Franco 2000, Zagona 2002, among others).

In turn, the base-generation hypothesis defends that clitics generate in the position in which they surface as affixes that are attached to their host.

⁴ Spanish only presents object clitics, in contrast with other languages which also present subject clitics (e.g. French), determiner clitics (e.g. Romanian), etc.

It has also been argued that clitics are heads of their own phrase (Uriagereka 1995, Sportiche 1996, among others). Thus, authors such as Torrego (1995) and Uriagereka (1995) defend that Spanish clitics (and also verb agreement in Basque) are, in fact, heads of DPs. Cuervo (2003), on the other hand, defends that dative clitics are heads of an Applicative Phrase and argues that ditransitive constructions in Spanish parallel so-called Double Object Constructions (DOCs) (e.g. *I gave him the book*) in languages such as English, which have also been analyzed as Applicative constructions (Pylkkänen 2002).⁵

On the linear ordering of clitics

As we have seen, crucial issues such as the position of clitics in the structure and even the nature of clitics have been subject to intense debate. Clitics constitute a very heterogeneous group, which display notably different properties across languages, even among those belonging to the same linguistic family, and providing unified accounts with cross-linguistic validity for the mixed properties of clitics has proven to be a very challenging endeavour. A particular aspect which continues to intrigue and puzzle scholars corresponds to the relative ordering of clitic sequences, as well as the restrictions that arise when two or more clitics are combined.

In Old Romance languages, clitics displayed an ACCUSATIVE > DATIVE linear ordering (also referred to as ILLUM MIHI), although most of them shifted to the

⁵ In recent years, certain structures involving dative arguments have been analyzed under an Applicative analysis. In broad terms, this approach defends that dative arguments (indirect objects, but also other dative elements, such as the so-called ethical datives, datives of interest, etc.) are, in fact, Applicative Phrases since, rather than being direct arguments of the verb, they are licensed by a specialized head, namely the Applicative head (cf. Pylkkänen 2002, Cuervo 2003). This terminology comes from the analysis of Bantu languages, where indirect objects added to the verb structure are called “applied arguments”.

opposite order (DAT-ACC, or MIHI ILLUM) through time (Wanner 1987a, 1999; Nicol 2005; among others). Additionally, with respect to person, the 3rd > 2nd/1st order also shifted to 2nd/1st > 3rd (Wanner 1999).

However, this shift was not homogeneous in all languages and, thus, while some Romance languages currently display the shift in the ordering of both case and person (e.g. Spanish), other languages display a fixed MIHI ILLUM order (e.g. Italian), others retained the ILLUM MIHI ordering (e.g. Aragonese, Corsican), and yet other languages display mixed orderings (e.g. Modern French) (see Wanner 1999 and Nicol 2005 for a detailed analysis of several Romance languages).⁶ As we can see, the shift was neither complete, nor homogeneous in all languages, and the current linear ordering of Romance clitics is subject to important cross-linguistic variation.

Although different languages present different linear orderings, not all combinatorial possibilities of a given order are acceptable and not all sequences have the same grammaticality status across languages. As such, we find that sentences like (1) are grammatical both in French (1a) and Spanish (1b), and sentences like (2) are ungrammatical both in French (2a) and Spanish (2b). However, sentences like (3) are grammatical in Spanish (3b), but not in Spanish (3a).⁷

⁶ It is important to note that, in the case of Spanish, clusters that contain a 3rd person follow the DAT-ACC order and display the ordering shift in both case and person, as in (1b). However, combinations of 1st and 2nd person clitics tend to favour the ACC-DAT order, as we can see in (3a).

⁷ In (3), the accusative clitic *te* can also be analyzed as reflexive. In fact, as Nicol (2005) indicates, the reflexive reading seems to be the favoured one among Spanish speakers and, thus, these clitics will be labelled as reflexive in the remainder of the dissertation.

- (1) a) Il **me** **le** présentera à la fête.
 He 1.SG.DAT 3.SG.ACC introduce-FUT at the party
- b) Él **me** **lo** presentará en la fiesta.
 He 1.SG.DAT 3.SG.ACC introduce-FUT in the party
 ‘He will introduce him to me at the party’
- (2) a) *Il **me** **lui** présentera à la fête.
 He 1.SG.ACC 3.SG.DAT introduce-FUT at the party
- b) *Él **me** **le** presentará en la fiesta.
 He 1.SG.ACC 3.SG.DAT introduce-FUT in the party
 ‘He will introduce me to him at the party’
- (3) a) *Tu **te** **m’**es présenté à la fête.
 You 2.SG.ACC 1.SG.DAT-PST introduced at the party⁸
- b) Tú **te** **me** presentaste en la fiesta.
 You 2.SG.ACC 1.SG.DAT introduced at the party
 ‘You introduced yourself to me at the party’

An important aspect to note with respect to the previous ungrammatical sentences is that they are all syntactically well-formed, and that the ungrammaticality cannot be due to issues such as incorrect case assignment, agreement mismatches, etc. Consequently, these examples confront us with the fact that certain combinations of clitics are not attested or clearly ungrammatical even though they correspond to well-formed syntactic structures (Perlmutter

⁸ The French example has been assigned the ACC-DAT order in order to present parallel sentences in both Spanish and French. However, the ungrammaticality of the French sentence is not due to this, since the DAT-ACC ordering will also result in ungrammaticality in this case.

1971). Hence, the causes and motivations for the different combinatorial possibilities in different languages constitute yet another challenge for linguists.

Much work has been devoted to the search for universal accounts and generalized proposals that are valid for clitics and agreement markers in general and, in this light, some authors have searched for such explanations in the syntax, while others have turned to morphology.⁹

1.2. CLITIC RESTRICTIONS

A number of proposals have been put forward in order to account for the possible and impossible combinations of clitics in Romance languages. Some of these approaches (Perlmutter 1971 for Spanish, Wanner 1987b and Monachesi 1995 for Italian, among others) rely on templates which assign fixed slots for each clitic and which reproduce the exact linear order in which clitics surface when they are combined. These accounts assume that ungrammaticality arises when the clusters do not respect the ordering established by the template.

However, not all proposals rely on linear templates. Together with the search for an explanation of why clitics surface in the specific orders in which they do, there is an ongoing debate about whether the restrictions observed in clitic combinations are syntactic or morphological in nature. At the same time, clitic phenomena have been related to similar issues regarding agreement restrictions that have been observed in different languages, particularly within approaches that

⁹ Due to the nature and scope of this dissertation only a number of proposals are addressed in the following section, and, although representative, the selection of studies discussed here is by no means exhaustive. Nevertheless, those proposals which are particularly relevant for the dissertation are discussed with a certain amount of detail. In addition, and although they will not be discussed here, the reader is also referred to studies such as: Strozer (1976), Wanner (1999), Haspelmath (2004), Boeckx (2001), Grimshaw (1997, 2001), Legendre (2000a, 2000b), Gerlach (2002), Béjar and Rezac (2003), Nevins (2007), García (2009) and Rezac (2007, 2010), among others.

propose a syntactic analysis of clitic phenomena. Some representative examples, which will be discussed in more detail in the following sections of this chapter, include Anagnostopoulou (2003, 2005), Bianchi (2006) and Adger and Harbour (2007). Specifically, Anagnostopoulou connects clitic phenomena with Icelandic long-distance agreement in expletive constructions, Bianchi claims that animacy hierarchies are responsible for clitic phenomena and relates them with inverse agreement systems, or “animacy-based” systems, in Bianchi’s terms, and Adger and Harbour associate clitic restrictions with case syncretism observed in languages such as Kiowa.

Up to this point, it remains unclear whether clitic restrictions are morphological or syntactic in nature and scholars continue the search for theories that will provide a unified account and successfully explain clitic phenomena. The following sections present a discussion of a number of relevant proposals on the topic.

1.2.1. Morphological approaches

Perlmutter (1971)

Perlmutter’s (1971) study constitutes one of the first attempts to provide a systematized account for the order in which Spanish clitics surface when they are combined. He claims that the explanation for clitic orderings is not to be found exclusively in the syntax. Instead, he defends that clitic cluster constraints must be interpreted “as a template or filter that is applied to sentences generated by the transformational component” (Perlmutter 1971:19). Thus, he argues for a templatic approach and proposes that “(i)n all languages in which clitics move to a particular

place in the sentence, there are surface structure constraints on the relative order of clitics” (Perlmutter 1971:48). With respect to Spanish, Perlmutter proposes the following template, which arranges clitics by person:

(4) *se* > II > I > III

Perlmutter’s template reflects the strong bias towards clitic ordering by person, rather than by case, that is observed in Spanish. This is demonstrated by the fact that 1st and 2nd person clitic combinations in sentences like (5) can be ambiguous for some speakers. While the general interpretation is that the order is ACC-DAT, some speakers may also accept the DAT-ACC interpretation, thus viewing (5) as an ambiguous sentence (Harris 1995).¹⁰ Thus, for speakers who accept both readings, both (5a) and (5b) are grammatical.

(5) Ellos **te** **me** presentaron en la fiesta.
 a) They 2.SG.ACC 1.SG.DAT introduced at the party
 ‘They introduced you to me at the party’
 b) They 2.SG.DAT 1.SG.ACC introduced at the party
 ‘They introduced me to you at the party’

On the other hand, sentences like (6), also discussed in Harris (1995), are unanimously rejected, which supports an analysis that orders clitics by person, rather than by case.

(6) a) *Ellos **me** **te** presentaron en la fiesta.
 They 1.SG.DAT 2.SG.ACC introduced at the party
 ‘They introduced you to me at the party’

¹⁰ In line with the above discussed clitic shift from ACC-DAT (ILLUM MIHI) to DAT-ACC (MIHI ILLUM).

- b) *Tú **me** **te** presentaste en la fiesta.
 You 1.SG.DAT 2.SG.REFL introduced at the party
 ‘You introduced yourself to me at the party’

Another relevant contribution by Perlmutter (1971) is the so-called “*spurious se rule*” for Spanish, according to which whenever a 3rd person dative clitic and a 3rd accusative clitic are combined, the dative clitic must be spelled out as *se* in order for the sentence to be grammatical, as we can see in (7).

- (7) a) ***Le** **lo** envié a mi hermana
 3.SG.DAT 3.SG.ACC sent to my sister
- b) **Se** **lo** envié a mi hermana
 se 3.SG.ACC sent to my sister
 ‘I sent it to my sister’

Perlmutter’s (1971) proposal was a significant leap forward in the study of Spanish clitics and, in turn, it influenced much of the later work and generated a number of new proposals which attempt to explain the combinatorial patterns of clitics by different means. Here follow a number of studies which defend that clitic phenomena are morphological in nature.

Bonet (1991)

An influential proposal on clitic combinations is the so-called **me lui/I-II Constraint*, also known as the *Person Case Constraint* (henceforth PCC).

Taking an approach that aligns with Distributed Morphology (Halle and Marantz 1993), Bonet (1991) proposes the PCC, which divides languages into two

types: Strong and Weak PCC languages. On a general level, Bonet assumes that morphological features are organized hierarchically and that clitics, which are therefore organized in hierarchical structures, are mapped onto a template after all the morphological rules have been applied. In her template, which includes five to six slots, Bonet crucially makes the distinction between [Person] (1st and 2nd) and Non-[Person] clitics (3rd).¹¹ However, rather than a template based on person, as in the case of Perlmutter (1971), she proposes one based on case.

On a particular level, Bonet (1991) proposes the PCC, a restriction which she defends is universal in character although it surfaces in two versions: Strong PCC and Weak PCC. The Strong version of the constraint is reproduced in (8) and it is exhibited by languages like French. The Weak version is reproduced in (9) and it refers to languages like Spanish.

(8) Strong PCC: “In a combination of a weak direct object and an indirect object [clitic, agreement marker or weak pronoun], the direct object has to be third person.” (Bonet 1991:182)

(9) Weak PCC: “In a combination of a weak direct object and an indirect object [clitic, agreement marker or weak pronoun], if there is a third person it has to be the direct object.” (Bonet 1991:182)

This constraint in two versions implies that both Strong and Weak PCC languages allow for combinations that include only 3rd person clitics and reject combinations in which the indirect object is 3rd person and the direct object is 1st or 2nd, as we can see in (10) and (11), respectively.

¹¹ This distinction between 1st and 2nd person, on the one hand, and 3rd person on the other is also present in numerous studies (see Harley and Ritter 1998, 2001; Nevins 2006; among many others).

(10) a) Je vais **le** **lui** donner
 I go 3.SG.ACC 3.SG.DAT give
 ‘I’m going to give it to him’

b) **Se lo** voy a dar
 3.DAT¹² 3.SG.ACC go to give
 ‘I’m going to give it to him’

(11) a) *Il **me** **lui** a recommandé
 He 1.SG.ACC 3.SG.DAT has recommended
 ‘He has recommended me to him’

b) *Él **me** **le** ha recomendado¹³
 He 1.SG.ACC 3.SG.DAT has recommended
 ‘He has recommended me to him’

A crucial difference between the two groups, however, is the fact that Weak PCC languages accept combinations of 1st/2nd person clitics and Strong PCC languages reject them, as shown in (2), repeated here as (12) for convenience.

(12) a) Tú **te** **me** presentaste en la fiesta.
 You 2.SG.REFL 1.SG.DAT introduced at the party
 ‘You introduced yourself to me at the party’

b) *Tu **te** **m’**es présenté à la fête.
 You 2.SG.REFL 1.SG.DAT-PST introduced at the party
 ‘You introduced yourself to me at the party’

¹² Even though *se* is underspecified for case, instances of ‘spurious *se*’ will be labeled as DAT and instances of 3rd reflexive will be labeled as REFL for the sake of clarity.

¹³ As indicated in fn. 2, this sentence would be grammatical in *leísta* dialects of Spanish if *le* is analyzed as a DO. However, the acceptance of these sentences by *leísta* speakers is not problematic for the PCC since in those cases the 3rd person clitic is still the DO, as required by the Weak PCC.

The templatic approach, however, has been criticized by several authors (Harris, 1995; among others) and proposals which do not resort to fixed linear ordering templates have also been attempted. Such proposals include Harris (1995), Heap (2005) and Rivero (2008).

Harris (1995)

Harris (1995), like Perlmutter (1971) and Bonet (1991), also states that purely syntactic approaches are not able to completely account for the clitic combination patterns discussed in the literature. In fact, he states that “sequencing is independent of placement in that the internal organization of clitic clusters is not affected by the location of the cluster in syntactic structure” (p. 171). Consequently, he proposes a purely morphological approach along the lines of Distributed Morphology in order to explain clitic sequencing phenomena.

Harris, whose study focuses on Spanish, also defends that the impossibility to combine certain clitics, as shown in (13), cannot be phonological, since the same sound combinations exist in the language (in words such as *lotería*, *lateral*, *lelo*).¹⁴

- (13) a) *¿El libro? **Lo** **te** di ayer
 The book 3.SG.ACC 2.SG.DAT gave yesterday
 ‘The book? I gave it to you yesterday’

¹⁴ The claim that clitic cluster constraints cannot be due to phonological restrictions is shared by other authors, such as Heap (2005). On a similar note, Fernández Soriano (1999) explains that the phonological change of the clitic *le* into *se* in combinations of dative and accusative (the so-called *spurious-se* rule) is not an arbitrary phonological rule and that it reflects a morphological process (p. 1257). Specifically, Bonet (1991) and, later, authors such as Jackubowicz et al. (1998) and Rivero (2008) defend that the transformation of *le* into *se*, which is also the form of 3rd person reflexive in Spanish, is not a mere coincidence but rather a feature impoverishment strategy, since *se* is the most underspecified clitic in the inventory in terms of features.

- b) *¿La fotografía? **La** **te** di ayer
 The photograph 3.SG.ACC 2.SG.DAT gave yesterday
 ‘The photograph? I gave it to you yesterday’
- c) *El libro **le** **lo** di ayer a Manuel
 The book 3.SG.DAT 3.SG.ACC gave yesterday to Manuel
 ‘The book, I gave it to Manuel yesterday’

Moreover, even as clitics we may also find them together in grammatical sentences (14).

- (14) a) Al hablar**le** **lo** detesté
 To-the talking-3.SG.DAT 3.SG.ACC HATED
 ‘When I talked to him I hated him’
- b) Si sigues repitiéndolo**lo** **te** **lo** aprenderás
 If keep repeating-3.SG.ACC 2.SG.REFL 3.SG.ACC learn
 de memoria
 of memory
 ‘If you keep repeating it you will learn it by heart’

Harris (1995) discusses two crucial aspects in order to account for clitic clustering in Spanish, which are: 1) the fact that the Spanish clitic paradigm shows syncretism in some of its forms, and 2) the notion that morphological features are organized hierarchically, which is also present in Bonet (1991). However, in his proposal, Harris focuses on the first aspect and defends that the ordering of clitics is based on the generalization reproduced in (15) and subject to

the negative filters reproduced in (16), which constitute a set of reformulations of Perlmutter's (1971) template.¹⁵

(15) Syncretism precedes contrast

- (16) a) *X-s
b) *l-X
c) *[1 per]-[2 per]

Since, in Spanish, (16a) and (16b) are covered by the generalization in (15), Harris argues that clitic sequencing can be guaranteed by (15) and (16c).

Heap (2005)

Heap (2005) also proposes a morphological account in his study of Spanish clitic sequences, even though he defends that the most suitable approach may differ from one set of data to another. Thus, even though certain clitic phenomena may favour a syntactic analysis, other cases may be best analyzed from a morphological point of view.

With respect to previous analyses, Heap (2005) points out that Perlmutter's template, as well as all accounts that assume a fixed linear order for clitic clusters are challenged by non-standard examples, such as those represented in (17).

- (17) a) %**Me** **se** ha caído la manzana
 1.SG.DAT 3.REFL has fallen the apple
 'The apple fell down (I accidentally dropped the apple)'

¹⁵ In (16a), *s* corresponds to the clitic *se*. In (16b), *l* corresponds to clitics beginning with *l*, in other words, third person clitics *lo*, *la*, *los*, *las*, *le* and *les*.

- b) %**Te** **se** van a manchar los pantalones
 2.SG.DAT 3.REFL go to stain the pants
 ‘You are going to stain your pants’

Heap also argues against Optimality Theory (OT) accounts, such as Grimshaw’s (1997, 2001), claiming that they are too unconstrained and that they also fail to account for sentences like the ones in (17). He further discusses that neither fixed ordering templates nor OT accounts are able to accommodate the fact that singular and plural clitics behave differently, as we can see in the ungrammaticality of the sentences in (18) –in contrast with (17)–, but also in (19).¹⁶

- (18) a) ***Nos** **se** ha caído la manzana
 1.PL.DAT 3.REFL has fallen the apple
 ‘The apple fell down (We accidentally dropped the apple)’
- b) ***Os** **se** van a manchar los pantalones
 2.PL.DAT 3.REFL go to stain the pants
 ‘You (pl) are going to stain your pants’
- (19) a) No **te** **me** enfades
 NEG 2.SG.REFL 1.SG.DAT get mad
 ‘Don’t get mad (on me)’
- b) *No **os** **me** enfadéis
 NEG 2.PL.REFL 1.SG.DAT get mad
 ‘Don’t get mad (on me)’

¹⁶ These examples also contradict Bonet’s (1991) Weak PCC, since it becomes apparent that not all 1st and 2nd persons are possible. Further discussion on this issue will be provided in the following sections of this chapter, as well as in chapter 2.

Heap (2005) directly addresses these issues and proposes a constraint which predicts the lineal ordering of clitic clusters according to their structural complexity. In this respect, Heap also assumes that the morphological features of clitics are organized hierarchically and proposes a model based on Harley and Ritter (1998) which also includes elements from Bonet (1991). The Feature Geometry proposed by Heap (2005) is reproduced in (20):

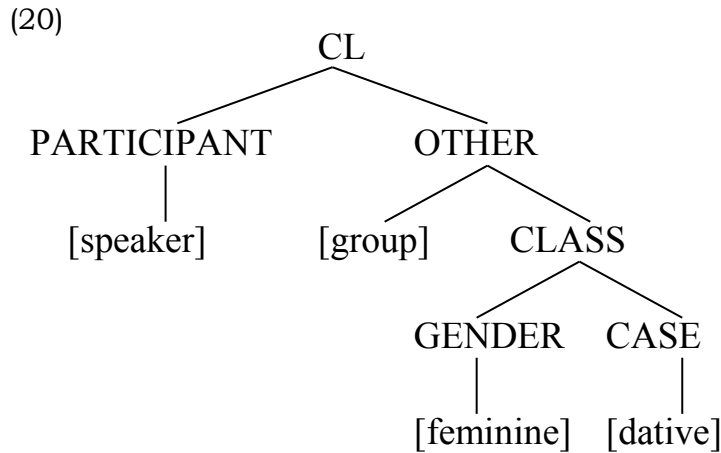

[Extracted from Heap 2005:90]

A relevant aspect of Heap's account is that, unlike most studies, he takes into consideration both non-standard clusters and the singular-plural distinction. Another noteworthy aspect of the hierarchy proposed by Heap (2005) is that, in addition to person and number, he also incorporates case in the Geometry.

Thus, by means of the Feature Geometry shown in (20), Heap proposes a constraint based on morphological structural complexity and feature markedness. This constraint, the *Least Leafy to the Left* (LLL), is reproduced in (21).

(21) Arrange clitics from the morphologically least specified to most specified.

According to this constraint, the least specified clitics must precede the most specified ones.¹⁷ Thus, *se*, which is the least specified clitic in the inventory, must precede all other clitics, as shown in (22).¹⁸

- (22) a) **Se** **los** devolvimos ayer a Pedro
 3.SG.DAT 3.PL.ACC returned yesterday to Pedro
- b) ***Los** **se** devolvimos ayer a Pedro
 3.PL.ACC 3.DAT returned yesterday to Pedro
- ‘We gave them back to Pedro yesterday’

In turn, 1st and 2nd must precede 3rd, as shown in (23) because 3rd accusative and dative –unlike 1st and 2nd, which are case syncretic– are specified by case.

- (23) a) **Te** **lo** he enviado por correo
 2.SG.DAT 3.SG.ACC have sent by mail
- b) ***Lo** **te** he enviado por correo
 3.SG.ACC 2.SG.DAT have sent by mail
- ‘I have sent it to you by mail’

Finally, plural, which contains an additional [group] node, must follow singular, as shown in (24).

¹⁷ Heap (2005:90) indicates that, with respect to the Feature Geometry, specificity –or markedness– correlates with structure and, as such, more complex structures are more marked. Consequently, a more specified clitic (e.g. 1st person clitic *me*) is more marked than a less specified one (e.g. 3rd person clitic *lo*) because it activates more nodes of the structure (in this case, the PARTICIPANT node).

¹⁸ This applies for all types of *se*, including the spurious type, given that, in either case, *se* is less specified than any other clitic in the inventory in terms of features.

- (24) a) ¿Por qué **te** **nos** pones tan triste?
 Why 2.SG.REFL 1.SG.DAT put so sad
 ‘Why are you getting so sad (on us)?’
- b) *¿Por qué **os** **me** ponéis tan tristes?
 Why 2.SG.REFL 1.SG.DAT put so sad
 ‘Why are you (pl) getting so sad (on me)?’

Rivero (2008)

Another morphological account is presented in Rivero’s (2008) discussion of Quirky Person Restrictions (QPRs). Without resorting to pronoun hierarchies, Rivero adopts a Distributed Morphology approach to account for person restrictions and focuses her analysis on phenomena arising in oblique subjects in Spanish.

Rivero notes that different constructions with the same morphology display similar patterns, regardless of their syntactic differences. In general, unaccusative constructions with psych verbs and dative subjects show no restrictions regarding person. However, we can find cases like (26b), where 1st plural and 2nd plural objects are not allowed.¹⁹

- (25) a) A Ana_i **le_i** apetecen ellos
 To Ana 3.SG.DAT yearn they
 ‘Ana yearns for them. They appeal to Ana.’
- b) A Ana_i **le_i** apetecemos nosotros
 To Ana 3.SG.DAT yearn we
 ‘Ana yearns for us. We appeal to Ana.’

¹⁹ All the examples from this section are taken from Rivero (2008). Subscripts have been added in order to identify the clitic reference.

- (26) a) A Ana_i **se_j** **le_i** antojan ellos_j
 To Ana 3.REFL 3.SG.DAT fancy they
 ‘Ana fancies them.’
- b) *A Ana_i **nos_j** **le_i** antojamos nosotros_j
 To Ana 1PL.REFL 3.SG.DAT fancy we
 ‘Ana fancies us.’

This type of restriction, labelled “Quirky Person Restriction” (QPR), recalls the limitation present in Icelandic by which nominatives can only be 3rd person in sentences with dative subjects (Sigurdsson 2004).

Other constructions that show similar patterns are psych constructions with inherent reflexives, as in (27), and inchoative constructions with datives, as in (28).

- (27) a) A Ana_i **se_j** **le_i** pasaron por la cabeza ellos_j
 To Ana 3.REFL 3.SG.DAT passed by the head they
 ‘Ana thought about them / They crossed Ana’s mind.’
- b) *A Ana_i **nos_j** **le_i** pasamos por la cabeza nosotros_j
 To Ana 1PL.REFL 3.SG.DAT passed by the head we
 ‘*Ana thought about us / We crossed Ana’s mind.’
- (28) a) A Ana_i **se_j** **le_i** quemaron ellas_j
 To Ana 3.REFL 3.SG.DAT burned they
 ‘Ana burnt them accidentally.’
- b) * A Ana_i **nos_j** **le_i** quemamos nosotros_j
 To Ana 1.PL.REFL 3.SG.DAT burned we
 ‘*Ana burnt us accidentally.’

- c) *A nosotros_i **os**_j **nos**_i quemasteis vosotros_j
 To us 2.PL.REFL 1.PL.DAT burned you.PL
 ‘*We burnt you accidentally.’
- d) *A vosotros_i **os**_i **nos**_j quemamos nosotros_j
 To you 2.PL.REFL 1.PL.DAT burned we
 ‘*You burnt us accidentally.’

Overall, we can see that all these constructions, though syntactically different, share morphology and, interestingly, they all show similar person restrictions as well.

Like Heap (2005), Rivero also takes into consideration the asymmetry between singular and plural persons, which seem to follow different combination patterns. Although Spanish has been argued to be a weak PCC language, as evidenced in (11) and also in (29a), the fact that the sentences in (28b-d) and (29b) are ungrammatical demonstrates that not all 1st and 2nd person combinations are possible. In fact, the ungrammaticality of (29b) aligns with the Strong PCC, rather than with the Weak PCC.

- (29) a) **Te**_i **me** antojaste tú_i
 2.SG.REFL 1.PL.DAT fancied you
 ‘I took a fancy to you’
- b) ***Os**_i **nos** antojasteis vosotros_i
 2.SG.REFL 1.PL.DAT fancied you.PL
 ‘We took a fancy to you (pl)’

Regarding QPRs, Rivero assumes that dative clitics in these constructions are marked [+m], which denote the participant with a mental state. In addition, 1st and 2nd persons carry a [+Participant] feature. Considering these two aspects, Rivero draws the following generalization:

- (30) The value of [Participant] in [+ m] clitics must be compatible with a value for [Participant] elsewhere in the clitic cluster.

In order to account for the seemingly mixed pattern of singulars and plurals, Rivero (2008) argues that the ungrammaticalities seen in (28b-d) and (29b) are due to morphological markedness. 1st and 2nd plural are the most marked clitics in the inventory because not only do they carry the marked feature [+Participant] but also a [+Plural] feature. Since these plural clitics have the richest combination of features in the Spanish paradigm, they become incompatible in a cluster.

1.2.2. Syntactic approaches

All the proposals discussed up to this point take a morphological approach to clitic clusters and restrictions and all of them agree with the view that syntax alone cannot account for the combinatorial patterns and restrictions observed in clitic clusters. However, there are a number of studies which defend that the explanation for clitic phenomena is to be found in the syntax.

Albizu (1997)

Albizu (1997), who deals mostly with data from Catalan and Basque, defends that the phenomena covered by the PCC may be best accounted for within

a model “under which Inflectional Morphology is derived in the Syntax” (Albizu 1997:3). Thus, he proposes his version of the PCC, reproduced in (31):

- (31) A Person-morphosyntactic feature P_1 must be less referential than, or as equally referential as, a Person-morphosyntactic feature P_2 that locally c-commands it at MC.²⁰

Like previously discussed morphological approaches (Bonet 1991, Heap 2005), Albizu assumes that clitics are organized in hierarchical structures, whereby 1st and 2nd person are more marked than 3rd person. However, and in contrast with purely morphological analyses, Albizu relies on the notions of c-command and locality to account for the phenomena observed when two clitics are combined.²¹ Specifically, the notion of c-command accounts for the asymmetries observed when two clitics are combined, given that, under Albizu’s analysis, dative (DAT) arguments c-command accusative (ACC) as well as absolutive (ABS) arguments and, in turn, ergatives (ERG) c-command both DAT and ABS.

In addition, by introducing the notion of locality (i.e. inclusion in the same minimal domain), the constraint becomes more restricted and leaves out elements such as ethical datives and inherent clitics which, according to Albizu, block the effects of the PCC.

Anagnostopoulou (2005)

A purely syntactic approach can be found in Anagnostopoulou (2005), which attempts to account for the asymmetry between 1st/2nd and 3rd person through

²⁰ MC refers to the Morphological Component.

²¹ Albizu’s definitions of locality and minimal domain stem from Chomsky (1993, 1995).

feature checking during the Agree operation of the syntactic derivation of structures containing two clitics.²² In particular, she proposes a competition analysis of the PCC. Also, she accounts for the cross-linguistic variability in the treatment of combinations of 1st and 2nd by means of Multiple Agree.

Anagnostopoulou assumes certain crucial differences between Direct Object (DO) clitics and their Indirect Object (IO) counterparts. Specifically, she assumes that all 1st and 2nd person clitics have a [Person] feature, and, with respect to 3rd person, she aligns with Adger and Harbour's (2007) proposal that, whereas 3rd person IO has a negative person specification, 3rd person DO lacks person specification altogether. Finally, she also assumes that both DO and IO check features against the same functional head: transitive ν .²³

The IO, which is in a higher position in the structure, and thus closer to the relevant functional head, moves and checks the person feature first. If DO is 3rd person, the IO checks person and the derivation is successful, since 3rd person DO does not contain the [Person] feature and, thus, there is no competition between the IO and the DO.

On the other hand, if the DO is 1st or 2nd, both the IO and the DO enter into competition for the [person] feature. The IO moves first, checking features against ν , but the DO is left without a [person] feature to check and, consequently, the derivation crashes.

In sum, the IO always checks [Person] and, whenever there is a situation in which the DO also has to check [Person] (i.e. when it is 1st or 2nd person), the

²² Béjar and Rezac (2003) take a similar approach and argue for cyclic agreement to account for PCC effects, which they also explore in other syntactic contexts, such as dative-nominative constructions.

²³ As Anagnostopoulou (2005:211) indicates, this corresponds to a 'two arguments against one head' construction (Chomsky 1995, 2000, 2001; Richards 1997).

derivation will crash. A simplified version of the movement of the IO and the DO to check features is represented in (32), below.

This competition between IO and DO is responsible for the universal ban on 3rd and 1st/2ndAcc combinations expressed by the Strong PCC.

In turn, in order to account for the acceptability of 1st and 2nd person combinations in some languages, Anagnostopoulou (2005) claims that 1st/2nd person clitic combinations are possible because Weak PCC languages allow for Multiple Agree.

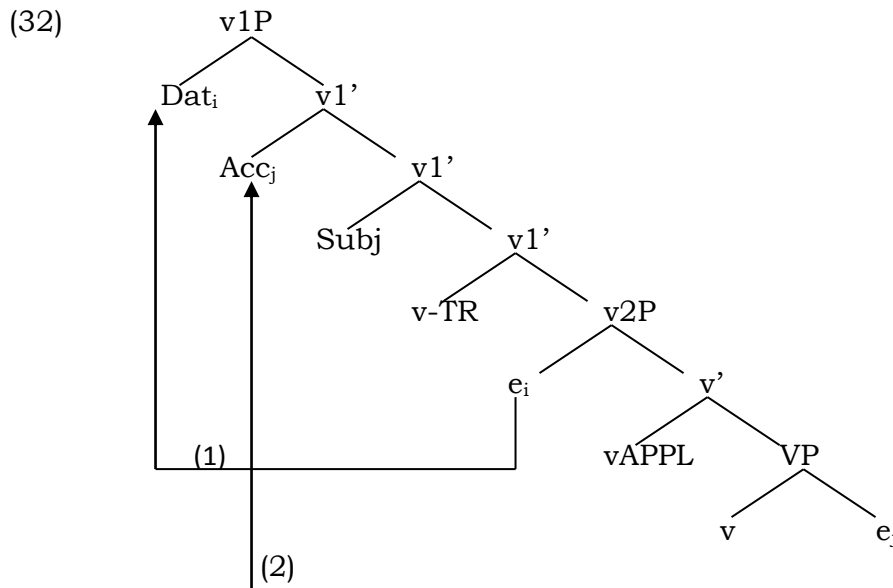

[Adapted from Anagnostopoulou (2005)]²⁴

Whereas in Strong PCC languages, 1st and 2nd clitics compete to check features against the same head, causing the derivation to crash, Weak PCC languages allow both DO and IO to check features simultaneously against transitive *v*. Thus, under Multiple Agree, the combination of 1st and 2nd person

²⁴ This tree is a combination of the trees in (26a) and (26b) in Anagnostopoulou (2005:213-214).

clitics becomes possible, which explains the grammaticality of the Spanish sentence in (2a), repeated here as (33a) (Weak PCC), and the ungrammaticality of the French sentence in (2b), repeated here as (33b) (Strong PCC).

- (33) a) Tú **te** **me** presentaste en la fiesta.
 You 2.SG.REFL 1.SG.DAT introduced at the party
 ‘You introduced yourself to me at the party’
- b) *Tu **te** **m’**es présenté à la fête.
 You 2.SG.REFL 1.SG.DAT-PST introduced at the party
 ‘You introduced yourself to me at the party’

However, as we have seen in the previous section (Heap 2005, Rivero 2008), not all combinations are possible and, in order to address this issue, Anagnostopoulou (2005) proposes that there is a condition for Multiple Agree to take place:

- (34) *A Condition on Multiple Agree:* “Multiple Agree can take place only under non-conflicting feature specifications of the agreeing elements.”

Anagnostopoulou argues that independent evidence for this condition comes from Icelandic long distance agreement in expletive constructions. In these constructions, it is impossible for the nominative and dative to enter into a Multiple Agree relation when the nominative is [+plural] and the dative is [-plural] and, consequently, the dative and the nominative elements can only agree when

they both have the same number specifications (i.e. when they are both singular and when they are both plural).^{25, 26}

The Condition on Multiple Agree successfully accounts for the grammaticality of (29a), reproduced here as (35a), as well as for the ungrammaticality of (35b).

- (35) a) **Te** **me** antojaste tú
 2.SG.REFL 1.PL.DAT fancied you
 ‘I took a fancy to you’
- b) ***Os** **me** antojasteis vosotros
 2.SG.REFL 1.PL.DAT fancied you.PL
 ‘I took a fancy to you (pl)’
- c) ***Os** **nos** antojasteis vosotros
 2.SG.REFL 1.PL.DAT fancied you.PL
 ‘We took a fancy to you (pl)’

However, it incorrectly predicts that sentences such as (29b), reproduced here as (35c), will be grammatical, thus failing to account for the asymmetry between singular and plural noted by Heap (2005) and Rivero (2008).

Ormazabal and Romero (2002, 2007)

In contrast with other recent syntactic proposals, like Anagnostopoulou (2005), who bases her analysis on the competition between IO and DO to check the

²⁵ As Anagnostopoulou (2005:223) indicates, a case in which the nominative is [-Plural] and the dative is [+Plural] cannot be tested, since these verbs surface as 3rd person singular when they do not enter long-distance Agree with the nominative.

²⁶ See Holmberg and Hróarsdóttir (2002) for further discussion on these constructions.

- (37) a) **Te** **lo** di
 2.SG.DAT 3SG.ACC gave
 'I gave it to you'
- b) ***Te** **le** di
 2.SG.DAT 3.SG.ACC gave
 'I gave him to you'

Drawing from these data from *leísta* Spanish, as well as from double object constructions (DOCs) in languages like Mohawk, Ormazabal and Romero (2002, 2007) provide an account for the PCC based on animacy. However, the authors defend that it is a broader phenomenon that covers more data than the examples traditionally assigned to PCC, and they propose a new generalization followed by an alternative constraint to the PCC, namely the Object Agreement Constraint.

(38) *Object Animacy Generalization*: Object relations, in contrast to subject and applied object relations, are sensitive to animacy.

(39) *Object Agreement Constraint (OAC)*: "If the verbal complex encodes object agreement, no other argument can be licensed through verbal agreement."

As we can see in (39), even though the authors claim that the crucial factor is animacy, they do not include it in their constraint. This is so because, according to the authors themselves, "from a theoretical perspective, it is not clear why the presence of animacy in object agreement would block agreement with the applicative object, and not the reverse" (Ormazabal and Romero 2007:339).

It is also important to note that the animacy to which they refer is syntactic, that is, it is part of the verb-object relation and it is relevant to the OAC only when it is part of object agreements. That is to say that, although the animacy feature is always related to animate nouns, verbs do not necessarily encode the feature every time the object is animate, since animate NPs do not trigger OAC by themselves. This justifies the articulation of the OAC “just in terms of presence vs. absence of agreement” (Ormazabal and Romero 2006:339).

Another relevant aspect of the OAC is that the specific roles of the other argument involved (goal, benefactive, etc) are not relevant for the constraint and, crucially, Ormazabal and Romero defend that the restriction is not linked to datives. Rather, they argue that it is independent of case specifications, thus being able to account for data which goes beyond the traditional PCC examples.

Adger and Harbour (2007)

In contrast with Ormazabal and Romero, who base their analysis on animacy, Adger and Harbour (2007) defend that the feature responsible for PCC phenomena is [Participant].²⁸

Adger and Harbour defend that the [Participant] feature is present in 1st and 2nd persons and in Romance 3rd person reflexives and IO clitics. However, it is not present in 3rd person DO.²⁹ In turn, the authors, who adopt an applicative analysis of dative arguments (Pylkannen 2002, Cuervo 2003), assume that the Appl head is defective and only carries number. Additionally, this head requires its specifier (the

²⁸ Adger and Harbour (2007) also introduce the notion of syncretism, but they argue against it.

²⁹ As mentioned above, these assumptions are shared by Anagnostopoulou (2005).

IO) to be [Participant]. Evidence for this proposal comes from Kiowa, whose IOs are always interpreted as semantically animate.³⁰

The above stated requirement implies that Appl cannot enter into an Agree relation with a [+Participant] argument and a violation of this requirement is what triggers the PCC effects seen in previous examples. An illustration of the Agree operations of these structures is reproduced in (40).

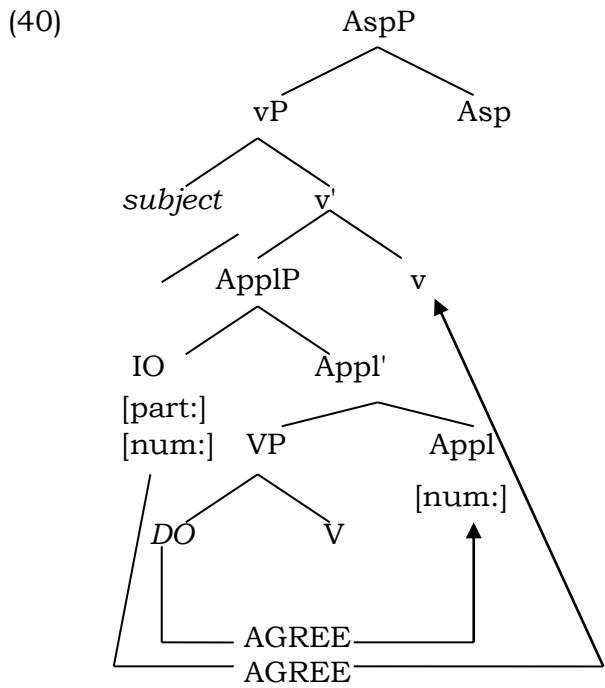

[Adapted from Adger and Harbour (2007:22)]

As shown in (40), the Appl head is in an Agree relation with the DO and, since it is a defective head, it can only enter in an agree relation with an element that does not carry the [+Participant feature]. If the DO is 1st or 2nd person, it will inevitably be [+Participant], so the Agree relation will be blocked and the derivation

³⁰ Adger and Harbour (2007) defend that this interpretation of IOs as animate is also present in Indo-European languages (p. 21).

will crash. On the other hand, when the Appl head is not present, the DO agrees with another functional head, and no restrictions apply.

Bianchi (2006)

Bianchi (2006) argues for an account of personal argument phenomena based on animacy. However, Bianchi (2006) takes a rather different approach than Ormazabal and Romero (2007), who also defend that animacy is responsible for clitic restrictions.

Bianchi defends that PCC phenomena are, in fact, an effect of an animacy hierarchy which determines the prominence of arguments. Thus, she argues that this is the case for animacy-based languages, such as Plains Cree but, crucially, non-animacy based languages, like Italian, also show effects that can be associated with an animacy hierarchy. Specifically, we can observe that Speech Act participants rank above 3rd person (Bianchi 2006:2029) or, in other words, 1st and 2nd person rank above 3rd.

Bianchi argues that, while this ranking of 1st/2nd above 3rd is universal, there is not one universally fixed animacy hierarchy and other distinctions are, in fact, language-specific (p.2026). As such, different languages make different options with respect to issues such as the relative ranking of 1st and 2nd person, on the one hand, and among 3rd person categories (animate/inanimate, proximate/obviate, etc) on the other hand.³¹

³¹ In contrast with authors such as Benveniste (1966), and, more recently Kayne (2000), Anagnostopoulou (2005) and Adger and Harbour (2007), among others, Bianchi (2006) defends that 3rd person is indeed a person and that “all pronominal arguments are intrinsically endowed with a person feature.” (p.2033)

In view of this, Bianchi (2006) defends that the PCC can actually be formulated in terms of animacy and proposes the following constraint in two parts:

- (41) Animacy hierarchy in Italian: first, second person, > third person
- (42) The DO cannot outrank the IO on the animacy hierarchy.

Bianchi agrees with Bonet's claim that this constraint is universal and explains that it allows for combinations in which the DO occurs with an equally or higher ranked IO, in other words, combinations of two 3rd persons and combinations of a 3rd person DO and a 1st/2nd IO. In turn, the constraint rules out combinations of 1st/2ndDO and 3rd person IO because in such cases, the IO has a lower degree of animacy than the DO.

This proposal shares with Heap (2005) the notion that a hierarchy is responsible for the clitic combination constraints observed in a wide range of languages. However, Heap proposes a morphological constraint and Bianchi provides a syntactic implementation of the hierarchy. In particular, Bianchi adopts a cartographic implementation in the sense of Cinque (2002) and Rizzi (2004), namely that "each distinct member of the animacy hierarchy is projected in a separate functional head of the clausal structure" (Bianchi 2006:2036).

Bianchi further assumes that "the relative ranking of the person feature is encoded in the relative syntactic order of the functional heads that license them: that is, third person is projected on a separate lower head than first and second person" (p.2036). The tree in (43) represents the structure of a well-formed cluster.³²

³² In the tree, SAP stands for Speech Act Participant, i.e. 1st and 2nd person.

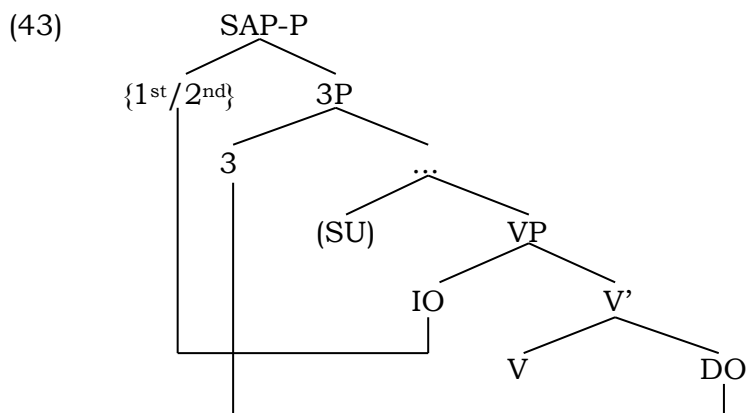

[Extracted from Bianchi (2006:28)]

In sum, under this analysis, elements with a higher degree of animacy (i.e. 1st and 2nd person) occupy a structurally higher projection than elements with a lower degree of animacy (i.e. 3rd person), as shown in (43), thus correlating animacy hierarchy and syntactic structure.³³

Săvescu (2009)

Săvescu (2009) presents a study on Romanian clitic combinations and argues against claims that the PCC is universal. Săvescu, like Heap (2005) and Rivero (2008), also discusses the asymmetry between singular and plural clitics, but, like Bianchi (2006), she takes a syntactic approach in the cartographic tradition. Specifically, Săvescu's analysis shares with Bianchi the presence of several person projections in the structure. However, Săvescu defends that case also plays a prominent role and argues for the presence of Kase in the cartography.

³³ The view that an animacy hierarchy has an effect in the syntax is also explored by Nichols (2001), who analyzes agreement restrictions in two unrelated languages: Kashmiri, which displays morphological case, and Picuris (Southern Tiwa), which does not.

Specifically, she argues for a movement analysis of clitics and defends that clitics move, first, to *K(ase)* in order to check accusative or dative case and, then, to *Person* in order to check the corresponding person features (p. 7). In both cases, each projection is rigidly ordered with respect to the rest of the structure. In the case of Romanian, Săvescu (2009) proposes the following structure (p. 190):

(44) Person1P>Person3P>Person2P>Refl3P>Person3P>TP>K-dat>K-acc>...>V

Clitic combinations in Romanian pattern very closely with Spanish. Thus, as we have seen in Rivero's (2008) Spanish examples in (29), sentences which combine two singular clitics, such as (45a), are grammatical, whereas sentences which combine two plural clitics, such as (45b), are ungrammatical.

- (45) a) **Mi** **te-ai** prezentat la petrecere.
 1.SG.DAT 2.SG.ACC-PAST introduce at the party
 'You introduced yourself to me at the party'
- b) ***Ni** **v-ați** prezentat la petrecere.
 1.PL.DAT 2.PL.ACC-PAST introduce at the party
 'You introduced yourselves to me at the party'

Crucially, 1st and 2nd person plural ACC and DAT clitics in Romanian are case syncretic in certain contexts, in contrast with their singular counterparts, which are always specified for person, number and case.^{34, 35} This leads Săvescu (and also Nevins and Săvescu 2010) to defend that the grammaticality pattern displayed in (45) is an effect of case syncretism. Thus, and in contrast with Adger

³⁴ Nevins and Săvescu (2010) (also Săvescu 2009) explain that, in order to diagnose syncretism, dative clitics must be looked at in isolation.

³⁵ See section 2.2.1 of this dissertation for further details on Romanian clitics.

and Harbour (2007), she defends that syncretism is, in fact, responsible for some of the effects that surface when clitics are combined.

1.3. CASE, FEATURES AND HIERARCHIES

Despite the ever-growing number of studies, the issue of whether clitic combinations and restrictions are governed by the rules of syntax or morphology is still unresolved and it has become apparent that finding a comprehensive explanation that successfully accounts for all the clitic phenomena is nothing short of challenging.

However, there are several aspects that are common to a number of the studies presented in the previous section, both in morphological and in syntactic approaches, which seem to be able to cover a significant amount of data.

First, several studies have pointed out that specific features are responsible for the effects found in clitic sequences. Notably, Person (Bonet 1991, Anagnostopoulou 2005, among others), Animacy (Ormazabal and Romero 2006, Bianchi 2006) and Participant (Adger and Harbour 2007) have been singled out as being responsible for the different grammaticality patterns found across languages.

Along these lines, another constant in a number of studies presented in this chapter is the notion that clitics are organized according to a feature hierarchy (Bonet, 1991, Bianchi 2006, Heap 2005, Săvescu 2009, among others) and that this hierarchy is also responsible for the ungrammaticality effects observed in certain clitic combinations.

Finally, a number of studies give special prominence to case and highlight its relevance to explain which sequences are grammatical and which ones are ungrammatical (Bonet 1991, Săvescu 2009, among others).

As we can see, regardless of the alignment with purely templatic, morphological, syntactic or mixed approaches, many of the studies on clitic sequences point in the same direction. Specifically, the idea that clitics are organized in hierarchical structures as well as the relevance of case and feature markedness are often present and discussed repeatedly in studies that attempt to account for the combinatorial possibilities of clitic combinations in different languages.

It has been argued that person, number and gender, on the one hand, and case, on the other, are not necessarily in the same natural class (Harley and Ritter 2002:507, in their discussion of Greenberg's Universals). Along these lines, Adger and Harbour (2008:2) make the distinction between phi-features (or φ -features), which are involved in predicate-argument agreement, and other features. Thus, case and φ -features (typically person, number and gender), would fall into different categories. However, the connection between case and φ -features has been widely explored and, as we have seen throughout this chapter, the interaction between the two is at the core of a number of studies that deal with clitic phenomena and the PCC. Accordingly, in Chapter 2, I further explore the interaction of case and φ -features in Spanish as well as in other Romance languages, with special focus on the notions of feature markedness and the hierarchical organization of clitic features, and argue that it is precisely this interaction that is responsible for clitic cluster effects observed in these languages.

With respect to the syntax/morphology debate, Cuervo (2002), in her analysis of clitic clusters in Spanish, defends that, although it is necessary to resort to syntax in order to successfully account for the phenomena observed when clitics are combined, purely syntactic accounts fail to provide comprehensive coverage of clitic cluster phenomena. Similarly, Adger and Harbour (2008) note that in studies dealing with ϕ -features, “the common themes that begin to emerge challenge the necessity of treating these domains of enquiry [syntax, semantics and morphology] separately” (p. 2). In line with these observations by Cuervo and Adger and Harbour, this dissertation shares the spirit that both morphology and syntax are necessary to provide a satisfactory account of clitic phenomena. Thus, the relevance and accuracy of a feature hierarchy in predicting grammaticality patterns of clitic clusters will be explored in Chapter 2, and, in light of the results of the experiments reported in Chapters 4 and 5, we will see that syntax also has an effect on the acceptability of clitic clusters. Therefore, the data presented in the following chapters of this dissertation support the idea that both modules must be taken into consideration in the analysis in order to provide a comprehensive explanation for the phenomena arising when clitics are combined.

2. ACCOUNTING FOR CLITIC RESTRICTIONS IN ROMANCE

In a number of recent studies, clitic constraints have been related to other phenomena, such as agreement restrictions and hierarchy effects found in a number of systems from different linguistic families (Bianchi 2006; Adger and Harbour 2007, among others). By establishing these links, scholars have pointed towards the idea that there is a common underlying motivation for the clitic phenomena observed in Chapter 1.

As we saw in previous sections, a number of studies that explore different ways to account for clitic phenomena in different languages have many points in common, such as the focus on specific features in order to determine which combinations are possible and which ones are not. In this chapter, I explore which issues are successfully accounted for by these proposals and which ones remain challenging. I will argue against templatic approaches and defend that both syntax and morphology need to be considered in order to fully account for clitic phenomena in different languages. I will, thus, argue that a unified account of

clitic restrictions with cross-linguistic validity needs to be addressed along the lines of what I will call the Feature Markedness Constraint, which constitutes a combination of the crucial aspects that most successfully account for clitic phenomena in Romance languages. These aspects, as suggested in section 3 of Chapter 1, are: 1) the notion that pronominal features are organized hierarchically, and 2) the effects of case and feature markedness in the acceptability of a cluster.

2.1. TOWARDS A UNIFIED ACCOUNT OF CLITIC RESTRICTIONS IN ROMANCE

As discussed in Chapter 1, Rivero (2008) notes that there is an asymmetry in Spanish with respect to combinations of singular clitics, on the one hand, and plural clitics, on the other hand.

- (1) a) Ellos **te** **me** presentaron en la fiesta.³⁶
 They 2.SG.ACC 1.SG.DAT introduced at the party
 ‘They introduced you to me at the party’
- b) *Ellos **os** **nos** presentaron en la fiesta.
 They 2.PL.ACC 1.PL.DAT introduced at the party
 ‘They introduced you (pl) to us at the party’

However, examples (2a) and (2b) show that there is yet another asymmetry with respect to 1st and 2nd person clitic combinations.

- (2) a) **Te** **nos** presentaste en la fiesta.
 2.SG.REFL 1.PL.DAT introduced at the party
 ‘You introduced yourself to me at the party’

³⁶ These examples are less readily accepted by Spanish speakers than examples containing a reflexive. Nevertheless, they are presented in order to illustrate all the different possible structures.

- b) ***Os** **me** presentasteis en la fiesta.
 2.PL.REFL 1.SG.DAT introduced-PL at the party
 ‘You introduced yourself to me at the party’

The sentences in (2) both carry the same amount of marked features and, yet, (2a) is grammatical and (2b) is ungrammatical, which indicates that the ungrammaticality found in these examples cannot be due to a mere accumulation of the marked features that make up the clitics in the cluster.

Authors such as Bianchi (2006) and Ormazábal and Romero (2007) have argued that ethical datives are not affected by the PCC, given that they are non-argumental clitics.³⁷ This, according to these authors, explains why 1st and 2nd person clitic combinations are allowed in such cases.³⁸

However, sentences with ethical datives, as the ones in (3), seem to undergo the same restrictions regarding singular/plural combinations that we saw in (1) and (2).

- (3) a) ¡Huy, que **te** **me** ensucias!
 Oops that 2.SG.REFL 1.SG.DAT stain
 ‘You are getting dirty’ (and I am affected by it)
- b) ¡Huy, que **te** **nos** ensucias!
 Oops that 2.SG.REFL 1.PL.DAT stain
 ‘You are getting dirty’ (and we are affected by it)

³⁷ Bianchi in particular argues that inherent reflexive clitics as well as ethical datives are not sensitive to the PCC and that the PCC is active only in the case of argumental clitics. She notes, however, that combinations of 1st inherent reflexives and 3rd datives are not acceptable (Bianchi 2006:2027).

³⁸ Along similar lines, Rezac (2010) suggests that only the Strong PCC is purely syntactic and that the explanation for Weak PCC effects is to be found elsewhere.

- c) *¡Huy, que **os** **nos** ensuciáis!
 Oops that 2.PL.REFL 1.PL.DAT stain
 ‘You (pl) are getting dirty’ (and we are affected by it)
- d) *¡Huy, que **os** **me** ensuciáis!
 Oops that 2.PL.REFL 1.SG.DAT stain
 ‘You (pl) are getting dirty’ (and I am affected by it)

In sum, the same restrictions surface with various structures, such as accusative-dative as in (1), reflexive-dative as in (2), and reflexive-ethical dative as in (3).³⁹ This means that, regardless of the analysis of the syntactic status of the various clitics, argumental or not, this restriction surfaces and is consistent throughout the different possible clitic combinations, including so-called “quirky person restrictions” like the ones in (4), as discussed by Rivero (2008).

- (4) a) **Te** **nos** antojaste tú
 2.SG.REFL 1.PL.DAT fancied you
 ‘We took a fancy on you’
- b) ***Os** **me** antojasteis vosotros
 2.SG.REFL 1.SG.DAT fancied you.PL
 ‘We took a fancy on you (pl)’

³⁹ The literature dealing with Spanish datives identifies several types of datives, both argumental and non-argumental (see Strozer 1976, Cuervo 2003, among others). In this dissertation, the differences between the different types of datives (benefactives, ethical datives, datives of interest, etc.) are not discussed at length and only the argument-adjunct difference is retained. Thus, argumental datives are labeled “dative” (or DAT) and the label “non-argumental dative” (or NAD) is henceforth used as a catch-all term for all types of non-argumental dative including ethical datives, benefactives, datives of interest, etc.

As defended by authors such as Harris (1995) and Heap (2005), the fact that sentences that reproduce the offending clitic sequence in different structures are grammatical, as we find in (5), shows that the pattern in (1-4) is not simply a phonological effect.⁴⁰

- (5) Al **veros** **me** alegré mucho.
To-the see-2PL.ACC 1.SG.REFL got.happy much
'When I saw you I got very happy'

As discussed in Chapter 1, Anagnostopoulou (2005) defends that the acceptance of 1st /2nd clitic combinations in the Weak PCC is due to the fact that certain languages allow for Multiple Agree. She further proposes the Condition on Multiple Agree, according to which the two pronouns of the cluster must not have conflicting feature specifications in order for Multiple Agree to take place. Crucially, this condition seems to be in place in Icelandic long distance agreement in expletive constructions, which also shows a blocking effect regarding plural. In this respect, Anagnostopoulou (2005:224) explains that “Multiple Agree in Icelandic is possible when both the dative and the nominative are [-plural] and impossible when the dative is [-plural] and the nominative [+plural].”

Thus, Icelandic provides evidence that supports Anagnostopoulou’s proposal, which also covers the mixed pattern in Spanish shown in (2). With respect to two plural clitics, as in (1b) and (3c), Anagnostopoulou’s proposal incorrectly predicts that such combinations will be grammatical, since they do not

⁴⁰ The reader is referred to Chapter 1 (p.7-8) for further details on Harris’s (1995) discussion on this matter.

have conflicting features. However, as discussed by Rivero (2008), these combinations in Spanish are not acceptable.

This incorrect prediction also arises in analyses such as the one proposed by Albizu (1997). Initially, Albizu's proposal covers the asymmetry between 1st/2nd and 3rd person, but it does not contemplate the effects of Number. However, even extending Albizu's analysis to cover Number as well, it would wrongly predict the acceptability of a cluster with two plural clitics, since it predicts the grammaticality of two clitics that are equally referential.⁴¹

Furthermore, as discussed in Chapter 1, the introduction of locality leaves out ethical datives and inherent clitics. However, we have seen in examples (1-4) that the singular-plural asymmetry also arises in clusters with ethical datives.

In Spanish, when 1st and 2nd person clitics are combined, the dative can be either singular or plural, whereas the non-dative element can only be singular when combined with a dative. In other words, there seems to be a blocking effect regarding number and the acceptance of a 1st/2nd cluster also depends on the case of the clitic carrying the [+Plural] feature. In more general terms, it seems that the acceptability of the clitic combinations presented above depends on two notions: case and feature markedness.

As we have seen in the previous chapter, Heap's (2005) proposal crucially includes a hierarchy that incorporates these two aspects and the restriction he proposes, the LLL constraint, successfully accounts for the grammatical and ungrammatical examples in Spanish that have been discussed so far.

⁴¹ The reader is referred to section 1.1.2 and section 2.2 of this dissertation for further discussion on Albizu's proposal.

Heap (2005) argues against fixed ordering constraints. However, even though the restriction he proposes does not provide fixed slots for each clitic, in practice, the LLL constraint still implies linear ordering. The wide amount of variation with respect to clitic clustering, however, seems to point toward the idea that the articulation of a restriction in terms of linear ordering, whether fixed or not, is bound to be too limiting, especially if we attempt to produce a general account that can be extended to other languages which do not necessarily arrange clitics in the same order as Spanish.

2.2. A FEATURE MARKEDNESS CONSTRAINT

To the best of my knowledge, there is yet to appear a comprehensive approach that successfully encompasses the ensemble of grammaticality patterns that arise when two clitics are combined. This is so in spite of the fact that a number of the available proposals point in the same direction and that they are, in fact, the proposals that seem to cover more ground.

Taking this into account, it becomes evident that it is necessary to formulate a restriction which combines the elements of these more successful approaches. Thus, a truly comprehensive proposal must be reformulated along these lines and reflect the effects of feature markedness and case, but without relying on linear ordering.

Additionally, given the wide diversity of acceptability patterns of clitic clusters in different languages, any generalization that is too categorical in nature is bound to encounter an important number of counterexamples. As such, I gear towards a generalization that is expressed in terms of preferences and guided by a

hierarchy which is grounded on the notions of feature markedness and case. In this sense, I agree with Haspelmath's (2004) claim that the ensemble of clitic restrictions seems to reflect preferences, rather than one fixed restriction. However, I defend in this chapter that this preference system is governed by a clear set of morphosyntactic rules and, therefore, I do not agree with Haspelmath's claim that it is a semantic-pragmatic issue and that the acceptance or rejection of a cluster merely comes as a result of the frequency in which these structures appear in the language.⁴² In my opinion, the very fact that the clitic phenomena observed here has many points in common with hierarchy effects and agreement phenomena observed in a wide number of languages from different families necessarily indicates that there must be a common underlying motivation for clitic phenomena and hierarchy effects beyond the frequency rates of these structures in a given language. Thus, I favour the proposal of a restriction that is dependent on feature markedness and case and which assumes a hierarchical organization of features. In this respect, my proposal shares the spirit of Heap (2005) and Bianchi (2006). In addition, given the fact that there is not one fixed order shared by all Romance languages and, thus, different languages display different combinatorial possibilities, I argue that the restriction cannot be expressed in terms of linear ordering. Thus, it is necessary to formulate a different type of generalization to determine which combinations are possible and which ones are not. I further argue that the specific linear/templatic ordering of clitics is necessarily language-specific, which was also suggested by authors such as Albizu (1997) and Cuervo (2002).

⁴² Similarly, Wanner (1999) defends that the reason why we only find certain clitic sequences in a given language is simply that they are the ones that are given to the speakers and that they are learned in that way during language acquisition.

Furthermore, a purely morphological analysis, such as Perlmutter (1971), but also Bonet (1991) or Heap (2005), fails to convey the fact that clitic phenomena also seem to have a distinctive syntactic motivation. As discussed in section 3 of Chapter 1, case reflects syntactic relationships and, as such, the fact that it is a main factor that affects the grammaticality patterns of clitic combinations may be taken as an indicator that these phenomena are, at least partly, syntactic in nature.⁴³ This means that a comprehensive account of clitic phenomena must combine both syntax and morphology, without relying on linear templates.

In addition, we have seen some aspects that are common to a number of proposals on clitic restrictions in Romance. These aspects may be condensed into one constraint based on two conditions:

- (6) A. In a combination of clitics, a dative clitic cannot be outranked in terms of marked features by a non-dative clitic.
- B. The acceptability of two clitics that contain equally marked features is language-specific.

Based on the discussion in Chapter 1 and section 1 of Chapter 2, this restriction, to which I will refer as the Feature Markedness Constraint, or FMC, contains the crucial elements of the approaches that seem to cover more data when it comes to clitic restrictions in Romance. Consequently, I propose that the FMC must be at the core of any successful account of clitic restrictions in Romance.

⁴³ See Chapter 1, section 3 for further discussion on the differences between case and ϕ -features (person, number and gender).

With respect to the FMC, I crucially assume that features are organized hierarchically and that the status of a feature as “marked” is determined by such hierarchy. Specifically, I assume an organization of clitic features in Romance that largely corresponds to the Feature Geometry proposed by Heap (2005) which, in turn, is an adaptation of Harley and Ritter’s (1998) Feature Geometry with elements from Bonet (1991). Heap’s Geometry, also discussed in Chapter 1 and in the previous section of this chapter, is repeated here with minor modifications as (7).⁴⁴

(7)

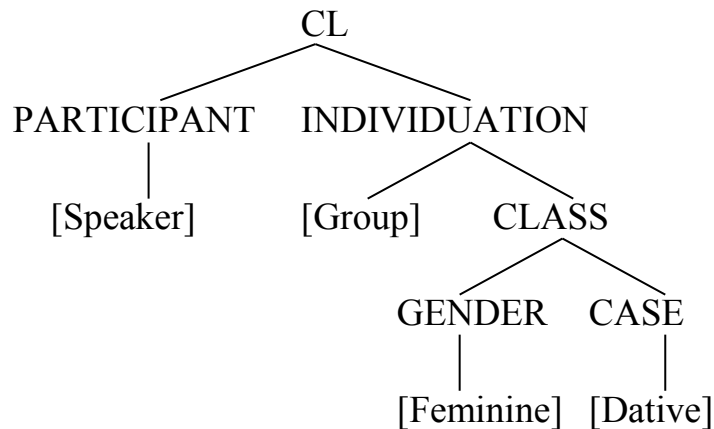

By means of a Feature Geometry like the one expressed in (7), we are able to explain why, crosslinguistically, 3rd person combinations are more acceptable than 1st and 2nd combinations, and why 1st/2nd plural are the least accepted.

First, we can observe that Person restrictions are made under the PARTICIPANT node and Number restrictions under the INDIVIDUATION node. Thus, according to the hierarchy, 3rd person clitics are the least marked of all, since they do not require the presence of the PARTICIPANT node (Harley and Ritter

⁴⁴ In order to prevent potential identifications between the node “OTHER” and 3rd person, I return to the label “INDIVIDUATION” for this node, as proposed by Harley and Ritter (2002a, 2002b), instead of retaining the label “OTHER” proposed by Heap (2005).

2002a:489). In other words, 3rd person clitics, whether singular or plural, build a less complex structure and, consequently, they are less marked than 1st/2nd. In turn, 1st and 2nd plural build a more complex structure than 1st and 2nd singular, since plural clitics also have the Group node activated and, as such, they are more marked than their singular counterparts.⁴⁵

Given the fact that the activation of the PARTICIPANT node necessarily builds a more complex structure, I crucially assume that it is the projection of this node that triggers further restrictions, which means that, in practice, Number restrictions will only be activated when Person restrictions are also activated.

With respect to clusters, the FMC predicts that some languages may accept two equally marked clitics, such as Spanish, which accepts two 1st/2nd singular clitics, whereas others will only accept combinations in which the dative clitic is more marked than the non-dative, such as French, which rejects 1st/2nd combinations altogether, as in (8a), and only accepts a 1st or 2nd clitic in the cluster when it is the dative, as in (8b).

- (8) a) *Tu **te** **m**'es présenté à la fête.
 You 2.SG.ACC 1.SG.DAT-PST introduced at the party
 'You introduced yourself to me at the party'
- b) Je **te** **l**'avais dit, n'est pas?
 I 2.SG.DAT 3.SG.ACC-had said NEG-is NEG
 'I told you, didn't I?'

⁴⁵ Also discussed by Harley and Ritter (2002a, 2002b) and Heap (2005).

Since Person and Number imply the activation of different levels of structural complexity in the Geometry, the FMC also predicts that a language that accepts two 1st/2nd singular clitics may reject two plural 1st/2nd clitics and that no language that accepts two plural 1st/2nd clitics will reject two singular 1st/2nd combinations.

Resorting to a Feature Geometry provides a structured explanation for the fact that different features trigger different acceptability patterns. Thus, the degree of markedness of a given feature will determine the acceptability of the cluster and, at the same time, each language determines which combinations of marked features are acceptable in a cluster.

However, as we have seen, is it not merely a matter of the amount of marked features in a combination and the syntactic structure must also play a role. When it comes to 1st/2nd combinations, structures with reflexives, as well as with ethical datives, are more readily accepted than structures with 1st/2nd ACC-DAT, although we still find the singular vs. plural effect in all cases, which constitutes further indication that both aspects, morphology and syntax, are interacting in these structures.⁴⁶

In fact, it is possible to integrate the observations presented throughout this discussion in a syntactic analysis. At this point, I remain uncommitted to a specific syntactic analysis of clitic combinations. Nevertheless, proposals along the lines of Albizu (1997), Anagnostopoulou (2005) or Bianchi (2006), with the incorporation of

⁴⁶ The preference for 1st/2nd REFL-DAT over 1st/2nd ACC-DAT has been hinted at in footnote 3 of Chapter 1 (p.5) and footnote 1 of this chapter (p.1) and will be discussed in more detail at the end of this section as well as in chapters 4 and 5.

the above mentioned hierarchy, might be good candidates to provide a comprehensive account of clitic phenomena in Romance languages.⁴⁷

Part A of the FMC (“in a combination of clitics, a dative clitic cannot be outranked in terms of marked features by a non-dative clitic”) may be expressed in more syntactic terms since, structurally, datives are placed in a structurally higher position than accusatives, as defended by Albizu (1997).⁴⁸ In this light, we may rephrase Part A as follows:

- (9) A. In a combination of clitics, the structurally higher clitic cannot be outranked in terms of marked features by the structurally lower clitic.

The resulting restriction is, in fact, very similar to Albizu’s (1997) GPCC, reproduced here as (10):

- (10) A Person-morphosyntactic feature P_1 must be less referential than, or as equally referential as, a Person-morphosyntactic feature P_2 that locally c-commands it at MC.

However, as discussed above and leaving aside the case of ethical datives, Albizu’s account does not cover mixed patterns such as the asymmetry between 1st/2nd singular and plural observed in Spanish since it wrongly predicts the acceptability of two equally marked clitics, so the addition of Part B in (6) is necessary in order to correctly predict such cases.

⁴⁷ The syntactic aspect of clitic restrictions will be further discussed in Chapters 4 and 5 in the light of experimental data that compare speakers’ reactions to various syntactic structures containing clitic clusters.

⁴⁸ This is the case for all the syntactic analyses discussed so far, including Applicative analyses of ditransitive constructions, such as Cuervo (2003) (see chapter 1, p.3-4), in which the Applicative Phrase is merged in a higher position than the accusative complement.

- (14) A) Combinations in which the non-dative is less specified than the dative are expected to be generally accepted
- B) Combinations in which the non-dative is as specified as the dative are expected to be accepted in some languages
- C) Combinations in which the non-dative is more specified than the dative are expected to be rejected.

The motivation for the three scenarios described above, within Anagnostopoulou's account, is the competition between the non-dative and the dative arguments for the ϕ -features in the Agree operation.⁴⁹ We have seen that Person and Number features both play a crucial role in the patterns of acceptability of different clitic combinations, but they must be considered separately in order to successfully account for the asymmetries between 1st and 2nd person on the one hand and singular and plural on the other. Crucially, and even though most of the focus of her analysis remains on the Person feature, Anagnostopoulou defends that ϕ -features are indeed checked separately. Specifically, she proposes that "in constructions where a person restriction arises, ϕ -features are not checked simultaneously. Person is checked separately from number" (Anagnostopoulou 2005:210). She further assumes that "(s)plit ϕ -feature checking takes place whenever two arguments, an indirect object and a lower argument with structural case (accusative or nominative), relate to the same functional head via Move or Agree" and that, in those competition configurations, "the indirect object checks person and the lower argument checks number" (Anagnostopoulou 2005:210). In other words, the Dative argument checks features

⁴⁹ Béjar and Rezac's (2003) argument for cyclic agreement also aligns with this view.

first and, then, the other argument checks the remaining available features. The Multiple Agree operation that allows for split-feature checking predicts A and C. With respect to B, we may argue that it also predicts it in the sense that some languages allow for Multiple Agree whereas others do not.

Thus, if we extend the analysis on Person and the notion of split feature checking to Number and assume the FMC hierarchy, we are able to account for the fact that Spanish seems to behave as a Weak PCC language when it comes to Person, but as a Strong PCC language when it comes to Number. Languages which accept two [+Person, +Plural] clitics will, consequently, behave as Weak PCC languages for both Person and Number. As mentioned above, the opposite case is not possible, since it would mean accepting more marked structures and rejecting less marked ones. This, in turn, confirms the notion that Number restrictions are only activated when Person restrictions are also activated.

In sum, and in agreement with authors such as Cuervo (2002), I argue that both syntax and morphology take part in determining which clusters are acceptable in a given language. As we can see, existing syntactic analyses may allow us to explain clitic combination patterns, but the introduction of the morphological component is crucial in order to fully account for clitic phenomena crosslinguistically. Thus, I propose that a unified account of clitic restrictions in Romance must incorporate the set of guidelines expressed in the FMC which, on the one hand, argues in favour of a hierarchy-driven syntactic derivation in the spirit of Bianchi (2006) and, on the other hand, assumes language-specific linear ordering constraints. In other words, the FMC proposes that clitic features are organized according to a hierarchy. This hierarchy has an effect on the syntactic structure and, as a result, certain combinations and certain structures will be

acceptable, whereas others will not. This will be determined by the feature markedness filter presented in Part A of the FMC. In turn, purely morphological language-specific constraints, contemplated in Part B of the constraint, will determine the actual linear order of the acceptable combinations (2nd before 1st, se before all other clitics, ACC before DAT, etc). These constraints are necessarily language-specific, given the fact that clitic ordering is not fixed across languages.

Finally, two crucial aspects regarding the relationship between the syntactic structure and the acceptance of clitic clusters still seem to elude explanation, namely the fact that not only argumental but also non-argumental datives display the same restrictions, and that there is an apparent preference of 1st/2nd REFL-DAT combinations over 1st/2nd ACC-DAT. While keeping this in mind, at this point I retain the original wording of the FMC, as expressed in (6), which will serve as the set of theoretical guidelines for the remainder of this chapter, as well as for the discussion of diachronic data on Chapters 3 and experimental data on Chapters 4 and 5.

The following sections of Chapter 2 provide support for the FMC in Modern Spanish, as well as in other Romance languages. The issues regarding the differences between syntactic structures will be discussed in greater depth in Chapters 4 and 5 with the discussion of experimental data from native and non-native speakers of Spanish.

2.3. EVIDENCE FROM MODERN SPANISH

The FMC successfully accounts for the asymmetries observed in examples (1-4). In this section, I provide additional data that serves as further support for the proposal.

As discussed in Chapter 1, a well-known issue regarding Spanish clitics is the case of the so-called spurious *se* (Perlmutter 1971). As we can see in (15), spurious *se* appears in combinations of 3rd person clitics and it implies the replacement of the dative clitic *le* or *les* by the form *se*.

- (15) a) *Los libros **les** **los** dimos a mis padres
 The books 3.PL.DAT 3.PL.ACC gave to my parents'
 The books, we gave (them) to my parents'
- b) Los libros **se los** dimos a mis padres
 The books *se* 3.PL.ACC gave to my parents'
 'The books, we gave (them) to my parents'

A number of authors, such as Jackubowicz et al. (1998) and Rivero (2008) defend that *se* is underspecified for person and, therefore, it creates no conflicts with other adjacent clitics, since it has poor feature content. In fact, *se* is the most underspecified pronoun of the entire inventory in Spanish, since it is underspecified for both number and case.⁵⁰ Along these lines, Bruhn de Garavito, Heap and Lamarche (2002), further propose that *se* is also underspecified for the feature [Reflexive] and defend that the underspecification of *se* with respect to all these features is responsible for the intriguing properties it displays.

⁵⁰ Other pronouns that are also underspecified for case, like *me* and *te*, do carry a number feature.

The behaviour of Spanish clitic *se* has been widely discussed in the literature and the vast majority of analyses correspond to structures where *se* is a 3rd person clitic. However, there is a particular context in which *se* does not correspond to a 3rd person referent, but to a 2nd person one. This is the case of formal treatment in Spanish, which implies a 2nd person referent but uses 3rd person forms.⁵¹ As such, both the agreement morphemes and the clitics used in these cases correspond to 3rd person, as shown in (16).

- (16) a) Tú no **te** tienes que enfadar por esto
 You NEG 2.SG.REFL have that get.mad for this
 ‘You don’t have to get mad for this’
- b) Usted no **se** tiene que enfadar por esto
 You.FORMAL NEG se have that get.mad for this
 ‘You (formal) don’t have to get mad for this’
- c) Él no **se** tiene que enfadar por esto
 He NEG se have that get.mad for this
 ‘You don’t have to get mad for this’

We have seen that combinations of 1st and 2nd person clitics in which the non-dative is plural are ungrammatical in Spanish. However, those corresponding to formal treatment, like the one in (17), are grammatical even though the non-dative corresponds to a 2nd person and refers to a plural entity.

⁵¹ All the forms used in formal treatment in Spanish correspond to 3rd person with the exception of the strong pronouns *usted* and *ustedes*, which are specific for 2nd person formal treatment.

- (17) Pasen ustedes, que **se nos** van a enfermar si siguen
 Pass you.PL.FORMAL that *se* 1.PL.DAT go to sicken if continue
 en la calle.
 in the street
 ‘Come in, you are going to get sick if you keep waiting out in the street’

This is the case because, even though the clitic referent is a 2nd person plural, the actual clitic used in the sentence is the underspecified clitic *se* and, therefore, the offending features are not present, so the violation of the FMC is neutralized. By contrast, the clitic in (18) is fully specified for both person and number, and, consequently, the outcome is ungrammatical.

- (18) * Pasad todos, que **os nos** vais a enfermar si siguen
 Pass all that 2.PL.REFL 1.PL.DAT go to sicken if continue
 en la calle.
 in the street
 ‘Come in, you are going to get sick if you keep waiting out in the street’

In Latin American varieties of Spanish, 2nd person plural *vosotros* and its corresponding pronouns and verbal morphology are replaced by *ustedes* and its corresponding forms. This means that the restrictions caused by the presence of *os* in a cluster do not apply, since the actual forms used in such cases correspond to 3rd person and, therefore, they are underspecified for the potentially offending features.

The fact that the absence of offending features in the cluster neutralizes the ungrammatical effects of certain clitic combinations demonstrates that such features are at the core of the clitic phenomena discussed so far.

The following section provides further discussion of clitic phenomena in a number of Romance languages, namely, Romanian, Italian and Catalan.

2.4. EVIDENCE FROM OTHER ROMANCE LANGUAGES

2.4.1. Romanian

The linear ordering of clitics in Spanish and Romanian shows some crucial differences. Specifically, in Romanian, the dative clitic must precede the accusative one. In general, this is also the case in Spanish, particularly for 3rd person combinations, which always display the DAT-ACC ordering. However, as we have seen in section 1.2.1 (Chapter 1, pp. 6-7), the preferred order in 1st/2nd combinations is ACC-DAT, even though some speakers allow readings that correspond to either ACC-DAT or DAT-ACC.

Additionally, in Romanian, 1st person clitics must always precede 2nd person ones (see Săvescu 2007, 2009; Nevins & Săvescu 2008). In Spanish, the reverse order is in place, as 2nd person must precede 1st person. This means that Spanish is an effective mirror image of Romanian with respect to the ordering of 1st/2nd clitic combinations.

However, as we can see in the Romanian examples in (19), compared with the equivalent Spanish examples in (1-3), the ungrammaticalities surface in the same contexts in both Spanish and Romanian, which suggests that the same restrictions must hold for the two languages regardless of the fact that the

offending plural clitic is in first position in Spanish and in second position in Romanian.⁵²

- (19) a) **Mi** **te-ai** prezentat la petrecere.
1.SG.DAT 2.SG. ACC-PAST introduce at the party
'You introduced yourself to me at the party'
- b) **Ni** **te-ai** prezentat la petrecere.
1.PL.DAT 2.SG. ACC-PAST introduce at the party
'You introduced yourself to us at the party'
- c) ***Ni** **v-ați** prezentat la petrecere.
1.PL.DAT 2.PL. ACC-PAST introduce at the party
'You introduced yourselves to us at the party'
- d) ***Mi** **v-ați** prezentat la petrecere.
1.SG.DAT 2.PL.ACC-PAST introduce at the party
'You introduced yourselves to me at the party'

As discussed in Chapter 1, Săvescu (2009) and Nevins and Săvescu (2010) argue that the singular/plural asymmetry found in Romanian is an effect of case syncretism. Let us recall that, in Romanian, 1st/2nd singular clitics show an accusative-dative distinction, whereas 1st/2nd plural clitics are case syncretic.

However, as we can see in Table 2.1, Spanish 1st/2nd clitics, both singular and plural, are case syncretic and, yet, the restrictions are the same in both languages.

⁵² As in the case of Spanish, the ACC may also be interpreted as a reflexive.

Table 2.1. Accusative and dative clitics in Romanian and Spanish

	ROMANIAN		SPANISH	
	ACCUSATIVE	DATIVE	ACCUSATIVE	DATIVE
1SG	mă	mi	me	me
2SG	te	ți	te	te
3SG	l/o	i	lo/la	le
1PL	ne	ne/ni	nos	nos
2PL	vă	vă/v/vi	os	os
3PL	i/le	le/li	los/las	les

Therefore, the fact that Spanish shows case syncretism both in the singular and in the plural necessarily indicates that this aspect cannot be the underlying reason for the asymmetry observed between singular and plural clitic combinations.

The fact that clitic ordering in Romanian is the mirror image of Spanish and, yet, the same restrictions hold also constitutes solid evidence that the phenomena observed in both languages cannot be accounted for in terms of mere linear ordering. This means that a restriction such as Heap's (2005) LLL constraint, though successful in accounting for clitic phenomena in Spanish, is not viable for Romanian. Case syncretism, as we have seen, does not successfully account for the phenomena arising in Romanian and in Spanish either. The FMC, however, is able to account for the ungrammaticalities identified in both languages, since it correctly predicts the right ungrammatical cases and also allows for language-specific linear orderings.

2.4.2. Italian

Italian is generally classified as a Weak PCC language in the literature (Bonet 1991; Anagnostopoulou 2005; Nicol 2005; among others).

Bonet (1991) defends that some speakers of Italian accept 1st/2nd combinations with the same ambiguities with respect to the DAT-ACC/ACC-DAT ordering as in Spanish and Catalan, although she also notes that not all speakers accept Weak PCC constructions. This variability is also defended by authors such as Nicol (2005) and Bianchi (2006).

In her discussion of Italian, Bonet provides an example of a 1st and a 2nd clitic cluster, taken from Renzi (1988). Both clitics in the example, reproduced below, are plural:

(20)	Vi	ci	manderà
	2.PL.DAT	LOC/1.PL.ACC	send-FUT
	‘S/he will send us to you’		

Bonet explicitly mentions that she ignores the fact that *ci* can also be a locative and uses this example to further justify that the Weak PCC is active in Italian too. However, the analysis of *ci* as a locative, rather than as a 2nd person plural clitic, seems to be the favoured interpretation. Similarly, the clitic *ci* in (21) would typically be considered a locative, rather than a plural object clitic, by Italian speakers.

(21)	Ti	ci	sei	donato	completamente
	2.SG.DAT	LOC /*1.PL.ACC	are	given	completely
	‘You devoted yourself to that/*us entirely’				

It is worth noting that, while (21) does not violate the FMC because the dative is not outranked by the non-dative, this example contrasts with the strong tendency displayed by Spanish and Romanian to reject clusters that contain two plural clitics.

Gerlach (2002:131) proposes the following template for Italian, taken from Monachesi (1995):⁵³

(22) 1 > 2 > 3_{IO} > ci_{Loc} > si_{RefI} > 3_{DO} > si_{Imp} > ne

In turn, Nicol (2005), in his discussion on Morphological Opacity, indicates which clitic combinations are possible in Italian and which ones are not. Table 2.2 reproduces the distribution according to Nicol (2005).

Table 2.2. Distribution of 1st and 2nd person clitic clusters in Italian

COMBINATION	POSSIBLE / NOT POSSIBLE
<u>ti mi (2SG 1SG)</u>	<u>Not possible</u>
mi ti (1SG 2SG)	Possible
<u>vi mi (2PL 1SG)</u>	<u>Not possible</u>
mi vi (1SG 2PL)	Possible
ti ci (2SG 1PL)	Possible
<u>ci ti (1PL 2SG)</u>	<u>Not Possible</u>
vi ci (2PL 1PL)	Possible
<u>ci vi (1PL 2PL)</u>	<u>Not possible</u>

In view of Table 2.2, Gerlach's template seems to accurately predict the acceptability of clitic combinations in Italian, since all the non-possible

⁵³ Wanner (1987b) presents a similar linear template for Italian.

combinations present an order that contradicts the template. Thus, in the case of *ti mi* and *vi mi*, 2nd person precedes 1st person and, in the case of *ci ti* and *ci vi*, *ci* precedes 1st and 2nd person, respectively.

With respect to *mi ti/mi vi*, Nicols defends that, while these combinations are generally not accepted, some speakers marginally accept sentences such as (23a) and (23b).

- (23) a) **Mi** **ti** presentano
 1.SG.ACC 2.SG.DAT introduced
 ‘They introduce me to you’
- b) **Mi** **ti** presento
 1.SG.REFL 2.SG.DAT introduced
 ‘I introduce myself to you’

While some authors (Evans et al. 1978; Wanner 1987b) defend that both sentences in (23) are equally acceptable, other authors (Seuren 1976) argue that, as in the case of Spanish, the only acceptable structures in these contexts are the ones that contain a reflexive, that is, sentences like (23b). In addition, Nicols explains that there is a condition, discussed by Evans et al. (1978), on the acceptability of these clusters:

- (24) If the linear ordering is direct object-indirect object in the cluster, then the indirect object is [-Reflexive]

In practice, this means that, although sentences like (23) and (25) could potentially be ambiguous with respect to whether they correspond to the ACC-DAT or the DAT-ACC ordering, the favoured analysis is that of ACC-DAT or, rather, REFL-

DAT in the cases of (23b) and (25) and, consequently, the more marked clitic in the case of *mi vi* in (25) is the dative, as required by the FMC.

- (25) **Mi** **vi** presento
 1.SG.REFL 2.PL.DAT introduce
 ‘I introduce myself to you (pl)’

Overall, given the ambiguity of the examples discussed in the literature and the lack of agreement in how to treat certain structures, it is difficult to establish clear acceptability patterns of 1st and 2nd person clitic combinations in Italian. Nevertheless, none of the acceptable combinations seem to violate the FMC, since the dative is not outranked by the non-dative in any of them.

2.4.3. Catalan

In general, Catalan behaves like Spanish and Romanian with the exception that Catalan marginally accepts the combination of two plural clitics, as in (26c).

- (26) a) Tu **te’m** vas presentar a la festa
 You 2.SG.REFL-1.SG.DAT PAST introduce at the party
 ‘You introduced yourself to me at the party’
- b) Tu **te’ns** vas presentar a la festa
 You 2.SG.REFL-1.PL.DAT PAST introduce at the party
 ‘You introduced yourself to us at the party’
- c) ??Vosaltres **us** **ens** vau presentar a la festa
 You.PL 2.PL.REFL 1.PL.DAT Past introduce at the party
 ‘You introduced yourselves to us at the party’

- d) *Vosaltres **us** **em** vau presentar a la festa
 You.PL 2.PL.REFL 1.SG.DAT Past introduce at the party
 ‘You introduced yourselves to me at the party’

This marginal acceptance of two plural clitics contrasts with the observations in Spanish and Romanian discussed above. Instead, it patterns with the acceptance of the Italian cluster *vi ci* if we follow the analysis that *ci* is an object clitic and not a locative, as defended by authors such as Bonet (1991). However, in contrast with Italian, all clitics in the Catalan clusters in (26) are unambiguously object clitics⁵⁴. It is crucial to note, though, that the only example in which the non-dative outranks the dative is rejected, as predicted by the FMC.

It is worth noting, as well, that the grammaticality pattern displayed by the Catalan examples in (26) parallels the restriction on Icelandic long distance agreement in expletive constructions which leads Anagnostopoulou (2005) to propose the Condition on Multiple Agree.⁵⁵

Thus, we can see that certain structures in some languages may accept combinations of maximally marked pronouns, but none of the languages discussed so far accept combinations in which a non-dative element outranks the dative in terms of marked features.

In sum, in view of the data presented above, we can conclude that a restriction such as the FMC is able to account for clitic phenomena occurring in languages such as Romanian, Italian, Catalan and Spanish.

⁵⁴ The locative clitic in Catalan is *hi*.

⁵⁵ See Chapter 1 (p.27) for further details on Anagnostopoulou’s (2005) analysis.

2.5. FINAL REMARKS ON THE FMC AND INTERIM SUMMARY

All the languages discussed in the previous section share the fact that combinations in which the non-dative outranks the dative are deemed less acceptable than those in which the dative is more marked than the non-dative. Some languages, such as Catalan and possibly Italian, marginally accept combinations of maximally marked features.

We have also seen that both Person and Number trigger restrictions, although they do not do so simultaneously and, as such, a language may accept combinations of two clitics that are marked for Person (i.e. combinations of 1st/2nd), but not for both Person and Number (i.e. combinations of 1st/2nd plural).

All the languages discussed so far share one version or another of these restrictions regardless of the linear ordering of their clitics. Therefore, linear ordering violations are not responsible for all clitic cluster ungrammaticalities. As we have seen in the case of Spanish and Romanian, these acceptability patterns are not due to syncretism either.

Rather, the data analyzed in this chapter point towards a restriction which is guided by a hierarchical organization of features and which is present in several structures, with both argumental and non-argumental clitic pronouns.

We have also seen that, while a number of syntactic analyses may provide grounded support for the clitic phenomena observed in the data, the inclusion of the morphological component is crucial in order to fully account for clitic combination patterns across languages.

The FMC, repeated here as (27), constitutes a combination of key elements found in a number of accounts of clitic restrictions and it relies on the notion that

clitic features are organized in a hierarchy which has an effect on the syntactic structure.

- (27) A. In a combination of clitics, a dative clitic cannot be outranked in terms of marked features by a non-dative clitic.
- B. The acceptability of two clitics that contain equally marked features is language-specific.

Part A of the FMC determines which combinations are acceptable and Part B contemplates language-specific variation in terms of both the degree of markedness accepted in a cluster and the specific linear ordering in which clitic clusters are produced in a given language.

In the case of Spanish, and also in Romanian, we have seen that there is a clear-cut distinction in the acceptance of clitic clusters in which the non-dative clitic is singular, in opposition to those in which it is plural. Furthermore, this distinction applies regardless of whether the clitics in the cluster are argumental or not. This restriction is captured by the Narrow Plural Blocking Effect (Alba de la Fuente 2010), which states that “in a combination of 1st and 2nd [person] clitics with a dative, the non-dative cannot be plural” (p. 213). In fact, the NPBE represents the specific version of Part B of the FMC that applies to Spanish.

The question that may arise now is whether this has always been the case, that is, whether the FMC has also been active in previous stages of Spanish. Chapter 3 provides a detailed analysis of diachronic data in order to provide an answer to this question.

3. THE FMC IN PREVIOUS STAGES OF SPANISH

The amount of variation with respect to clitic clusters found across languages of the same family, as seen for Romance in Chapters 1 and 2 of this dissertation, raises the question of whether there has been variation within each language as well. More specifically, we have seen that different languages display different versions of a seemingly universal set of constraints, which may lead us to inquire about the evolution of these constraints in a given language and, furthermore, whether the variation found both across languages and within a language are, in fact, indicative of language change.⁵⁶ These are largely unexplored issues, since most studies dealing with clitic restrictions make insightful cross-linguistic comparisons but leave aside the study of the evolution of these restrictions in a given language.

In turn, and with respect to Spanish, the focus of studies within the philological tradition typically deal with issues such as the evolution of all pronouns from the Latin paradigm to the Spanish paradigm with an emphasis on phonological and morphological changes (see Lapesa 1986[1942], Menéndez Pidal 1966[1904] and, more recently, Penny 2002 and Cano Aguilar 2005). These studies

⁵⁶ One example of variability within a language is the lack of uniformity in the acceptance of 1st and 2nd person clitic clusters in Italian, as discussed in Chapter 2 section 4.2.

also discuss the appearance and development of new forms such as *nosotros* (we), *vosotros* (you, plural) and *usted* (you, formal), as well as the relative position of clitics in the sentence, both with respect to the verb (i.e. whether they appear pre- or post-verbally) and to the other elements in the sentence (see Ramsden 1963; Wanner 1987a, 1999 and Nieuwenhuijsen 2006 for discussion of seminal work on clitic position in the sentence, including that of Tobler, Mussafia and Wackernagel). The evolution of the syntactic status of clitics has also been explored by authors such as Rivero (1986, 1997) and Fontana (1993, 1997). The discussion of possible and impossible clitic combinations has typically remained at the periphery of diachronic studies of Spanish and observations are often scattered throughout the analysis of other pronoun phenomena. A noteworthy exception is the discussion of the evolution of 3rd person IO and DO, which evolved from Latin *ILLI ILLUM* to Old Spanish *gelo* and, eventually, to Modern Spanish *se lo*. This discussion is directly linked to the previously discussed notion of spurious *se*.⁵⁷ Along similar lines, the study of the shift from *ILLUM MIHI* to *MIHI ILLUM* has also received attention in studies dealing with Romance languages (Wanner 1987a, 1999; Nicols 2005), as discussed in Chapter 1.

All these aspects constitute central issues in the philological tradition. However, recent formal proposals on clitic restrictions have not incorporated diachronic analyses and, as such, the historical evolution of clitic restrictions from perspectives such as the PCC (Person-Case Constraint) or the FMC (Feature Markedness Hypothesis) remains unexplored.

⁵⁷ This phenomenon has long intrigued scholars and it has been studied both from a diachronic and synchronic point of view, as discussed in the introduction of the so-called spurious *se* (Perlmutter 1971) in Chapters 1 and 2.

Contrary to this trend, the aim of this chapter is to explore the status of Spanish clitic combinations through time in light of the analysis presented in Chapter 2 and to investigate whether Modern Spanish (henceforth ModSp) restrictions such as the ban on combinations of two plural 1st/2nd clitics also hold in previous stages. Consequently, the study presented in this chapter opens a new line of investigation, as it combines recent proposals on ModSp clitic combinations with diachrony and the notion of language change.

Section 3.1 presents a brief overview of clitics in Old Spanish (henceforth OldSp) with a discussion of some of the central issues in the philological tradition, mentioned previously. Section 3.2 presents a diachronic study of the evolution of clitic clusters in Spanish which, for a more targeted and in-depth analysis, focuses on 1st and 2nd clitic combinations. The data for this section have been extracted from the Diachronic Corpus of Spanish (CORDE) by the Real Academia de la Lengua Española. Finally, section 3.3 provides the conclusions of the diachronic study presented in the previous section.

3.1. A BRIEF OVERVIEW OF CLITICS IN OLD SPANISH

Given the gradual nature of the changes that lead a language to shift from one stage to the next, it is difficult to determine with precision when such transitions occur. With respect to Spanish, it is normally assumed that the change from OldSp to ModSp takes place around the 15th century (Rivero 1986). Some of the characteristics of ModSp are visible at much earlier dates, whereas certain features of OldSp are more pervasive. Nevertheless, the differentiating characteristics of OldSp, such as the ones presented in this section, had

practically disappeared by the 16th century, hence the placement of the shift from OldSp to ModSp during the 15th century. In sum, the label OldSp roughly refers to the period between the 11th and the 15th centuries, whereas the label ModSp refers to the period between the 16th century and today.

3.1.1 The development of the Spanish pronoun paradigm: From Latin to Spanish

The Spanish pronominal system derives, for the most part, from the Latin pronominal paradigm. However, Latin only had specific pronoun forms for 1st and 2nd person and used demonstratives to refer to a 3rd person, particularly ILLE and its derivative forms, so Spanish 3rd person pronouns actually derive from this Latin demonstrative.⁵⁸ At the same time, Latin pronouns, like nouns and adjectives, had declinations which provided information about person, number, case and gender. These declinations were lost for nouns and pronouns and, in the case of pronouns, this loss gave rise to a paradigm that groups pronouns into stressed and unstressed categories. Table 3.1, adapted from Penny (2002), presents the complete paradigm of Spanish pronouns and the corresponding Latin forms from which they derive.⁵⁹

With respect to stressed pronouns, ModSp subject pronouns derive, for the most part, from the Latin nominative counterparts, with the exception of 3rd masculine plural (ILLOS), which is accusative.

⁵⁸ In order to prevent any confusion between Latin and Romance pronouns, small capitals are used for Latin and lower case is used for Romance throughout the dissertation.

⁵⁹ As discussed below Table 3.1, it is important to note that the Latin equivalent corresponds only to the actual form from which the Spanish pronoun is derived (see Penny 2002 for further discussion).

Table 3.1. Spanish pronominal system [adapted from Penny 2002:133]

		STRESSED				UNSTRESSED			
		SUBJECT		OBJECT OF A PREPOSITION		ACCUSATIVE		DATIVE	
		Latin	Spanish	Latin	Spanish	Latin	Spanish	Latin	Spanish
SINGULAR	1	EGO	yo	MIHI	mí	ME	me	ME	me
	2	TU	tú	TIBI	ti	TE	te	TE	te
	3-MASC	ILLE	él	ILLE	él	ILLUM	lo	ILLI	le
	3-FEM	ILLA	ella	ILLA(M)	ella	ILLAM	la	ILLI	le
	3-NEUT	ILLUD	ello	ILLUD	ello	ILLUD	lo	ILLI	le
PLURAL	1	NOS	nos(otros)	NOS	nos(otros)	NOS	nos	NOS	nos
	2	VOS	vos(otros)	VOS	vos(otros)	VOS	(v)os	VOS	(v)os
	3-MASC	ILLOS	ellos	ILLOS	ellos	ILLOS	los	ILLIS	les
	3-FEM	ILLAS	ellas	ILLAS	ellas	ILLAS	las	ILLIS	les
SG/PL	3-REFL			SIBI	si	SE	se	SE	se

Pronouns which follow prepositions are derived mainly from the Latin accusative forms, except from 1st and 2nd singular and 3rd reflexive, all of which derive from Latin dative forms.

With respect to the unstressed forms, all accusative forms, 1st and 2nd dative (both singular and plural) and 3rd reflexive derive from Latin accusative pronouns.

In addition to the forms that have a direct Latin counterpart, we have 1st and 2nd plural *nosotros* and *vosotros*. In Latin, *VOS* was a 2nd person plural pronoun, but it was also used for deferential address to a single person (Penny 2002). This is maintained in OldSp and is still used in other Romance languages, such as French. Thus, in OldSp, *vos* was both a plural and a singular (deferential) pronoun. In order to provide contrast between singular and plural referents, the word *otro* ('other') was combined with *vos*. In turn, *nosotros* was formed by analogy with *vosotros*.

With respect to the ModSp deferential form *usted/es*, the use of *vos* became so widespread that, by the 15th century, its deferential value was almost lost and new forms of address began to appear (Penny 2002:138). Thus, *vuestra merced* and its variants became the deferential forms of address and, after successive contractions including *vuesa merced*, *vuesarced*, *voacé*, *vuced*, etc., the form *usted* eventually became the deferential pronoun (Lapesa 1986: 392).⁶⁰

3.1.2. Clitic position in the sentence

OldSp and ModSp display different syntactic properties with respect to clitics. Among the main differences, we find the position of the clitic in the sentence with respect to the verb.⁶¹ In ModSp, a clitic must always precede finite verbs and follow non-finite verbs and imperatives, as illustrated in (1).

- (1) a) ¿Ese libro? **Lo** tengo desde hace años
 That book 3.SG.ACC have since makes years
 ‘That book? I’ve had it for years’
- b) Es imposible comprender**lo**
 is impossible understand-3.SG.ACC
 ‘It is impossible to understand it’
- c) Escúchame, por favor
 Listen-ACC.1.SG please
 ‘Listen to me, please’

⁶⁰ As indicated in Chapter 2, the agreement morphemes and pronouns associated with *usted* correspond to the 3rd person. This is due to the fact that *vuestra merced*, its originating expression, triggered 3rd person agreement.

⁶¹ For a detailed analysis of clitic position in the sentence, the reader is referred to Nieuwenhuijsen (2006).

In OldSp, however, a clitic could appear either preverbally or postverbally regardless of whether the verb was finite or non-finite.

(2) a) E él **le** dixo que **le** plazía, e fizolo así.

And he 3.SG.DAT said that 3.DAT pleased and did-3.SG.ACC thusly

‘He said that it pleased him, and he did it that way’

Sendebat (c 1253)

b) E dixole cauallero bien seades venjdo vos &

and said-3.SG.DAT sir well be come you and

vuestro conpañõ

your companion

‘And he told him: “Sir, you and your companion, be welcome”’

Cuento de don Tristán de Leonís (c 1313-c1410)

Additionally, clitics could be separated from the verb by another constituent, which is not possible in ModSp. Thus, as we can see in (3), the subject and object of the sentence could surface between the clitic and the verb. This phenomenon is known as *interpolation* (Ramsden 1963; Rivero 1986; Fontana 1993; among others).

(3) E, señor, si **le** vos esto hazedes, haredes como rrey noble...

And sir if 3.SG.DAT you this do do.FUT like king noble

‘And, Sir, if you do this to him, you will behave as a noble king...’

Gran crónica de Alfonso XI (c 1348 - 1379)

Also, in contrast with ModSp, clitics in OldSp could be attached to various lexical items, as we can see in (2b), where it is attached to a verb, and in (4), where it is attached to a complementizer.

- (4) Don Rinalt (...) tomo las cartas **quel** dio el Rey. pora
 Mr. Rinalt (...) took the letters that-3.SG.DAT gave the king for
 donna Costança
 Ms. Constança
 ‘Mr. Rinalt took the letters that the king gave him for Ms. Constança’
Gran Conquista de Ultramar (1293)

Finally, a distinctive feature of ModSp is the so-called “clitic doubling”, by which accusative and dative clitics may co-occur with their corresponding full DPs in the sentence, as shown in (5).

- (5) **Le_i** enviaron un ramo de flores a María_i
 3.SG.DAT sent a bouquet of flowers to María
 ‘They sent a bouquet of flowers to María’

Crucially, this co-occurrence is not only possible but obligatory in certain cases.⁶² By contrast, clitics and their corresponding DPs are in complementary distribution in OldSp, as shown in (6).

⁶² In Standard Spanish, accusative clitic doubling is obligatory when the corresponding DP is fronted and there is no contrastive focus, as in (i) (see Zubizarreta 1998 for a detailed analysis on this issue).

(i) Los platos_i los_i lavo yo.
 The dishes ACC.3.PL wash I
 ‘The dishes, I wash them’

In turn, dative –and accusative– clitic doubling is obligatory, among other cases, when the full DP contains a pronoun, as in (ii).

(ii) Le_i vendí mi apartamento a ella_i.
 DAT.3.SG sold my apartment to her
 ‘I sold my apartment to her’

(6) a) E enuiaron **a el** omnes buenos & sabios.

And sent to him men good and wise

‘And they sent him good and wise men’

Gran Conquista de Ultramar (1293)

b) quando se leuanto, dieron**le** vn buen cauallo,

when 3.SG.REFL stood gave-3.SG.DAT a good horse

‘When he stood up, they gave him a good horse’

La demanda del Sancto Grial (c 1470)

In sum, when it comes to clitics in Spanish, the progression from one stage to the next is marked by the loss of the OldSp characteristics and the settling of the ModSp ones (Rivero 1986; Fontana 1993; among others).

3.1.3. The syntactic status of clitics in Old and Modern Spanish

The syntactic status of clitics and their changes through the different stages of the language are discussed in detail by Rivero (1986) and, later, by Fontana (1993, 1997). Syntactically, ModSp clitics are analyzed as phrasal heads (Rivero 1986; Fontana 1993, 1994) and many authors consider that they actually are bound morphemes, or verbal affixes (Rivero 1986; Saltarelli 1987; Franco 1993; Fontana 1993, 1994; among others).⁶³ When it comes to previous stages of Spanish, however, Rivero (1986) explains that phenomena such as interpolation, and the other properties listed above, serve as evidence against the classification of OldSp clitics as bound morphemes. In fact, the author defends that, rather than bound morphemes, OldSp clitics “have the properties of heads of maximal

⁶³ See Fernández Soriano (1999) for further discussion on this issue.

projections” (1986:804). This view is shared by Fontana (1993, 1994, 1997), who argues that OldSp clitics evolved from maximal projections (X^{MAX}) to head-related categories (X^0). In turn, Fontana (1997) defends that OldSp was a language that manifested both V2 and 2P phenomena.⁶⁴ So, X^{MAX} clitics were reanalyzed into X^0 clitics as the V2 and 2P characteristics were eventually lost.

Rivero (1997) provides a different analysis. She argues that OldSp presented two alternative systems regarding clitics. On the one hand, we have *Complementizer* or C-oriented clitics, which are observed mainly in non-root clauses. They are almost always in second position (2P) and they are not adjacent to the verb. On the other hand, clitics that are adjacent to the verb, and may appear in positions other than 2P, are *Inflection* or I-oriented clitics. In the evolution from OldSp to ModSp, the C-oriented system was lost and the Spanish clitic system evolved from a mixed pattern of C-oriented and I-oriented to one that was exclusively I-oriented. As a consequence, the differentiating characteristics of OldSp clitics seen in the previous section gradually disappeared.

Clitic clusters

As we saw in Chapter 2, a number of proposals have attempted to account for the combinatorial patterns of clitic clusters in ModSp. The Feature Markedness Constraint, or FMC, which constitutes a combination of the main elements of these

⁶⁴ One of the characteristics associated to OldSp clitics is known as the second position clitic, or 2P clitic, by which clitics do not appear in first position in a matrix sentence. Instead, they typically appear after a non-clitic element which occupies the first position. Although this phenomenon was already noticed in the philological tradition (by authors such as Lapesa 1986[1942]), among others), it is further discussed and analyzed by authors such as Fontana (1993, 1997) and Rivero (1997). Another second position phenomenon that has been well developed in the literature is V2, or verb-second. The V2 phenomenon has typically been associated with Germanic languages such as German. However, Fontana (1997) defends that it can also be observed in Romance languages, such as OldSp. In his analysis he considers both phenomena to account for the behaviour of clitics in OldSp.

proposals, defends that: 1) in a cluster which includes a dative, the dative clitic cannot be outranked by the non-dative clitic, and 2) the acceptability of two clitics that contain equally marked features is language-specific.

The Plural-Blocking Effect, henceforth PBE, (Alba de la Fuente 2010) shares the spirit of the FMC and explains that there is a ban in Spanish on combinations in which the non-dative is plural. Given the fact that 2nd person must precede 1st and 3rd in a cluster, and that ACC typically precedes DAT in 1st/2nd combinations, we find that, in practice, a 2nd person plural cannot occupy the first position in the cluster. This phenomenon is also predicted by Heap's LLL constraint, which assumes that the first clitic of a cluster is never plural in ModSp.⁶⁵

As discussed at the beginning of this chapter, when it comes to the evolution of clitic combinations, as well as the combinatorial possibilities of clitics in previous stages of Spanish, studies within the philological tradition have focused more on the evolution of the 3rd person DAT-ACC combination from ILLI ILLUM to *gelo* and, eventually, to *se lo*. We have seen in the previous section that the fact that the combination of 3rd person DAT-ACC has developed into *se lo*, rather than the expected *le lo* has long intrigued scholars and, consequently, it has been discussed in a number of occasions (including Menéndez Pidal 1966[1904], Lapesa 1986[1966] and Cano Aguilar 2005, among others).

Combinations of 1st and 2nd clitics, however, have typically received less attention from a diachronic point of view. Thus, in view of the diachronic differences between clitics in OldSp and in ModSp, and also considering the synchronic differences across languages of the Romance family, a question arises

⁶⁵ See Chapter 1 (p.15-19) for further details on Heap's analysis of clitic clusters in Spanish.

on whether the FMC was also present in previous stages of Spanish, including those in which its clitics were structurally different.

In order to address this question, the following section reports the results of an analysis of 1st and 2nd clitic combinations in Spanish extracted from the Diachronic Corpus of the Real Academia Española (CORDE), which includes texts ranging from the earliest texts available to the late 20th century.

3.2 A DIACHRONIC ANALYSIS OF SPANISH CLITIC CLUSTERS

Diachronic studies confront a number of intrinsic difficulties and limitations. First, the only available source of data is the set of written texts that have survived through time. In addition, and in contrast with synchronic analyses, oral data and native speakers' intuitions and judgments are unavailable for analysis. It is also impossible to find counterexamples or ungrammatical cases in the data that will support, or challenge, a hypothesis. Thus, it is not possible to compare and contrast the data with other sources, which occasionally results in the impossibility to determine the appropriate analysis of a given structure.

In addition, the fact that we only have written language to analyze brings up issues on the differences between written and spoken language. Written language is arguably more conservative than oral language, which implies that this medium makes use of expressions, structures and vocabulary items that may no longer be used in the oral language or that belong exclusively to the written language.

However, regardless of the potential difficulties that diachronic analyses have to face, it is still possible to draw conclusions from diachronic data and the

information extracted from them may be valid to identify the usage patterns and trends of a given structure through time.⁶⁶

In the case of clitic combinations, positive evidence that contradicts the state of affairs presented in Chapter 2 is to be considered as support against the idea that the FMC holds for previous stages of Spanish. Alternatively, the absence of examples that contradict the FMC will be considered as a positive indicator for the validity of this proposal throughout the history of Spanish.

This section introduces a study on clitic clusters using diachronic data extracted from CORDE, which constitutes the largest diachronic corpus of Spanish available, with a total of 250 million forms and a wide range of texts (including chronicles, legal documents, narrative texts, poetry, theatre, etc.) from the earliest texts written in Spanish to 1974.

For this diachronic analysis, I take the restrictions that are active in ModSp as the baseline. In particular, the proposal that I retain for the description of clitic restrictions in ModSp is the Narrow Plural-Blocking Effect (Alba de la Fuente 2010), henceforth NPBE, according to which, “in a combination of 1st and 2nd [person] clitics with a dative, the non-dative cannot be plural” (p. 213).

Thus, the research questions that guide this diachronic study are the following: Is the NPBE active in previous stages of Spanish? If it is not, are the non-compliant cases still subject to the FMC (i.e. is it the case that the non-dative clitic does not outrank the dative in the cluster)?

The following sections provide the methodology and results of the diachronic analysis.

⁶⁶ See Fontana (1993), Chapter 1 for further discussion on the issues and difficulties associated with diachronic analyses.

3.2.1 Methodology

The study included data extracted from the entire corpus with no period limitation, although the majority of the tokens date between 1377 and 1650. All types of texts were considered for the analysis, although certain types, particularly poetry and lyric texts were considered with added caution.

The data from CORDE were obtained by using the search engine of the corpus. In order to extract the data, each clitic cluster that was relevant for the research questions was entered in the search engine and all the tokens found were retrieved together with their full contexts. Then, each token was analyzed and labeled. Finally, all the relevant tokens were extracted from their contexts, classified and grouped. A number of representative tokens were extracted from their contexts and listed together to form a set of examples which will be partially presented throughout this section. Additionally, Appendix A includes a table with the distribution of all the cases returned by the search engine classified by cluster.

The data and results of the analysis are presented and discussed by cluster in the *Results* section. Since the clusters analyzed are combinations of 1st and 2nd and the number feature is crucial in determining which clusters are acceptable and which ones are not in ModSp, the clusters are grouped according to whether they contain two singular clitics, two plural clitics or a mix of singular and plural clitics. In turn, each cluster is discussed separately under its corresponding sub-section.

3.2.2. Results

3.2.2.1. Combinations of singular clitics

Te me

A total of 724 tokens was found for the cluster *te me*. A large number of cases correspond to the 1500-1600 and 1600-1700 periods (253 and 110 cases, respectively), but the cluster is present in all periods and we find examples throughout the entire the corpus (roughly between 1250 and 1975).

The abundance and continued presence of *te me* in the corpus indicates that 1st and 2nd person clusters have been accepted in ModSp as well as in previous stages of the language. In this case, both clitics are singular, so all the tokens comply with both the NPBE and the FMC.

3.2.2.2. Combinations of plural clitics

In ModSp, *nos* and *os* are both plural pronouns. In OldSp, however, both *nos* and *os* may refer to either singular or plural entities. In the case of *nos*, we have the so-called majestic plural, by which persons of a high status, typically monarchs, religious authorities, etc., refer to themselves as “we”.⁶⁷

In the case of *os*, which presented the two alternative spellings *vos* and *os* in OldSp, one of its uses was as a deferential form of address with singular referents. In Latin, *VOS* was a 2nd person plural pronoun, but it was also used for deferential address of a single person (Penny, 2002). This is maintained in the evolution into Spanish and, so, in OldSp, we have *vos/os* both as plural and as singular

⁶⁷ The use of majestic *nos*, as well as other uses of *nos* as a singular pronoun such as the so-called editorial or author’s *we*, also exist in ModSp.

(deferential) pronouns. This implies that there were two *vos/os* in OldSp: one with a [+Plural] feature, and one without it.

In addition, *nos* and *vos* may be both a stressed and an unstressed pronoun and, therefore, it may function as a subject and object of a preposition (strong pronoun) as well as an object pronoun. With respect to the 2nd person pronoun, *vos* could be either a subject or an object pronoun, whereas *os* is generally associated with the object pronoun paradigm. This implies that a number of the combinations of *nos* and *vos/os* returned by the engine may not be clitic clusters but rather pronoun sequences unrelated to the FMC. Here follow the results for the search of the following combinations: *os nos*, *nos os*, *vos nos* and *nos vos*.

Os nos

The cluster *os nos* is not possible in ModSp and it violates both the NPBE and the FMC. This being said, this cluster is expected not to be found in the corpus. Accordingly, as predicted by the FMC, no examples of *os nos* were found. However, several examples of the clusters *nos os*, *vos nos* and *nos vos* were found. Let us now turn to these clusters in order to discuss them in more detail.

Nos os

In contrast with the absence of *os nos*, there are 26 cases of *nos os* in the corpus. However, none of the cases constitute a challenge to the PBE or the FMC, since none of them are clitic clusters that are subject to these restrictions.

First, there are eight cases in which *nos* is not an object clitic, but a subject, as shown in (7).

- (7) e **nos os** rogamos, por la fe que debes a todos los
 And 1.SG.NOM 2.SG.DAT beg by the faith that owe.2.SG to all the
 cavalleros, que nos lo otorgués.
 knights that 1.SG.DAT 3.SG.ACC give
 ‘And we (majest.) beg you to give it to us (majest.), by the faith that you owe
 to all the knights’

El baladro del sabio Merlín con sus profecías (1400-1498)

Similarly, in eight other cases, *nos* is the object of a preposition, as we can see in (8).

- (8) y conforme al tenor de la dicha instruccion que por **nos os**
 and according to the content of the said instruction that by 1.SG 2.SG.DAT
 fuere dada
 were given
 ‘and according to the instructions that would be given to you by us (majest.)’
Carta Real Patente aprobando y confirmando la avenencia y concierto entre el
Obispo de Calahorra y e ... (1539)

There are also three cases in which *nos os* is not a cluster either because the two clitics are actually part of an enumeration of pronouns, as illustrated in (9).

- (9) Ai otros que no rreziben se, sino me, te, i **nos, os**
 Have others that NEG receive se but me te and nos os
 ‘There are others who do not carry se, but me, te and nos os’

Correas, Gonzalo, *Arte de la lengua española castellana* (1625)

In 7 cases, *nos* may be interpreted as a negative adverb or, possibly, as an apocope of *se* after the negative adverb. In some cases, as in (10), the apocope analysis seems correct.

- (10) para sienpre xamas **nos** **os** sera quitada por mas ni por
 for always never NEG-3.IMPERS 2.SG.DAT be.fut taken for more nor for
 menos ni por el tanto ni por otra rraçon alguna en ninguna ni
 less nor for the much nor for another reason any in none nor
 alguna manera (...)
 any way

‘It will never be taken away from you, neither for more, nor for less, nor for any other reason or in any other way’

Traslado de una escritura sobre la compra de la capilla mayor del Convento de Santa Úrsula de Toledo... (1623)

However, in other cases, the presence of *se* does not seem justified and the most likely analysis is that of *nos* as a form of negation. Such is the case of (11).

- (11) Probadme que **nos** **os** burláis y yo os obedeceré
 Prove.1SG.Dat that NEG? 2.SG.REFL mock and I 2.Sg.Acc obey.FUT
 ‘Prove to me that you are not mocking me and I will obey you’

Rimas y prosas (1627)

Typically, *nos* is not considered a possible spelling for negation in Spanish, so these cases may be some sort of misspelling.⁶⁸ In these cases, whether they are

⁶⁸ I have also found cases where *nos* could be interpreted as a negation when analyzing other clusters containing *nos*, namely *vos nos* and *nos vos*, so, even if it may be a misspelling, the phenomenon seems to be somewhat widespread.

analyzed as instances of apocope or as negation, these instances of *nos os* do not constitute a violation of the FMC either, since neither structure is an FMC context.

In sum, even though we have tokens of the combination *nos os*, which seems to be incongruent with the FMC, a closer analysis shows that none of the cases actually contradicts the FMC because they are all cases in which the restriction does not apply.

Vos nos

243 cases of *vos nos* were found. In most of the cases, *vos* is a subject pronoun (142 cases), as we can see in (12).

- (12) Vimos lo que **vos** **nos** screuistes con el padre Fray Bernat Buyl
Saw.1Pl what 2.SG.NOM 1.SG.DAT wrote with the father Fray Bernat Buyl
'I saw what you, together with father Fray Bernat Buyl, wrote to me'

Don Fernando a Garcilaso de la Vega, sobre la respuesta de Buyl (1492)

In 24 other cases, mostly between the 13th and 15th centuries, we find cases of interpolation, in which *vos* is an object clitic and *nos* is the subject pronoun. We can see two examples in (13) and (14).

- (13) desta casa con so sobrado que **vos** **nos** vendemos
of-this house with *so sobrado* that 2.SG.DAT 1.SG.NOM sell
'... of this house with *so sobrado*, that we (majest.) sell you'

Carta de compra [Documentos de los archivos catedralicio y diocesano de Salamanca] (1249)

- (14) e ponemos convusco de nunca ir contra esta cesión e donación que
 and put.1.SG with.you of never go against this transfer and donation that
vos nos fazemos
 2.SG.DAT 1.SG.NOM do
 ‘and we (majest.) tell you never to go against this transfer and donation that
 we (majest.) give you’

Carta de venta [Documentos del Archivo Histórico Nacional (a1200-a1492)] (1377)

As noted by authors such as Fontana (1994), the phenomenon of interpolation disappears during the 16th century. In fact, some texts from that period argue against the appropriateness of this phenomenon. For example, Juan de Valdés, in his *Diálogo de la lengua* (1535-1536), argues that the order in which the subject is placed between the object clitic and the verb is old-fashioned and that it is no longer correct. Specifically, he writes: “Paréceme también mal aquella manera de dezir "si me vos prometéis" por "si vos me prometéis"” (p. 250).

Once again, given the fact that one of the pronouns in the pair is always a subject pronoun, none of these cases of *vos nos* correspond to the type of cluster that is subject to the NPBE and FMC, since one of the elements (i.e. the subject pronoun) is not a clitic, but a stressed pronoun. Therefore, none of the instances which include a subject pronoun, regardless of whether it is in first or second position, represent a challenge for the FMC. In consequence, these cases are not counterexamples for the FMC.

In addition to either *nos* or *vos* being a subject, in 47 cases, *vos* corresponds to an object of a preposition, as exemplified in (15). Once again, these cases do not

correspond to the type of cluster discussed in this study and, therefore, they do not represent a challenge for the FMC.

- (15) y que por **vos nos** sea embiada informacion o certifficacion de la
and that by 2.SG 1.SG.DAT be sent information or certification of the
cantidad...
quantity...
'and that the information on the quantity (...) be sent to us (majest.) by you'
*Fernando al cónsul de catalanes en Venecia con propuestas de pago a Ulisses
Salvador y Martín Bolser... (1490)*

Finally, there is only one clear case of a FMC context, which is reproduced in (16).

- (16) Amiga buena, bendita sea la ora que vos Dios aduxo a este
Friend good blessed be the hour that 2.SG.ACC god brought to this
monesterio e **vos nos** dió.
monastery and 2.SG.ACC 1.SG.DAT gave
'My/Our good friend, blessed be the hour in which God brought you to this
monastery and gave you to us (majest.)'
Cuento muy fermoso de Otas de Roma (1300-1325)

In this case, *vos* has a singular referent and, therefore, it lacks the offending [+Plural] feature, so it complies with the NPBE and the FMC.

Nos vos

481 cases of *nos vos* were found in the corpus. The overwhelming majority of the cases (392 cases) have *nos* as the subject of the sentence, as in (17).

- (17) *destas dichas casas e corral que **nos** **vos** vendemos*
of these said houses and stockyard that 1.SG.NOM 2.SG.DAT sell
'of these houses and stockard that we (majest.) sell you'

Carta de venta [Documentos del Monasterio de Santa Clara de Villalobos] (1356)

As we have seen for *vos nos*, we also have 14 cases in which *vos* is the subject of the sentence, one of which is reproduced in (18).

- (18) ***nos** **vos** por ellas diestes en bonos dineros*
1.SG.DAT 2.SG.NOM for them gave.2.SG in good money
'You gave us (majest.) good money for them'

Carta de venta [Documentos del Monasterio de Santa Clara de Villalobos] (1370)

Additionally, in 52 cases *nos* is the object of a preposition and 8 cases are actually enumerations of the pronouns in the Spanish paradigm, so none of these cases challenge the NPBE and the FMC.

In five cases we find the construction “*nos os encomendamos*” (I/we commend myself/ourselves to you), where either *nos* is a plural pronoun or the text is ambiguous about whether the referent of *nos* is a singular or a plural entity. Three out of these five examples are actually different versions of the same letter. This leaves a total of three different contexts, two of which are reproduced in (19) and (20).

(19) **nos vos** encomendamos e vos fasemos saber que pleito esta
1.PL 2.SG.DAT commend.1.PL and 2.SG.DAT make know that lawsuit is
pendiente ante nos entre partes.

pending before 1.PL between parts

‘We commend (ourselves) to you and let you know that there is an unsolved
conflict between the two parties’

*Requerimiento [Colección diplomática del archivo municipal de Salvatierra (1451-
1488)] (1452)*

(20) Señor tio el Almirante de Castilla e el Adelantado Pero Manrique

Sir uncle the Admiral of Castille and the Governor Pero Manrique

nos vos mucho encomendamos.

1.PL 2.SG.DAT much commend.1.PL

‘Uncle, Admiral of Castile and Governor Pero Manrique, I/we commend
(myself/ourselves) to you’

Carrillo de Huete, Pedro, *Crónica del halconero de Juan II* (1454)

The verb *encomendar* has two possible structures in Spanish: one as a ditransitive verb, *encomendar algo a alguien* (‘commend something to someone’), and one as a reflexive verb, *encomendarse a alguien o a algo* (‘commend oneself to someone or something’). In addition, even though the reflexive use of the verb is present since the earliest examples, there are also non-reflexive uses of this verb, as we can see in (21).

(21) "encomendamos mucho al ylustrísimo Príncipe nuestro nieto el

Commend.1.PL much to the honorable prince our grandson the

ylustre *infante* don Enrrique, nuestro primo, y al duque de Segorbe
honorable infante don Enrique our cousin and to the duke of Segorbe
su hijo, nuestro sobrino

his son our nephew

‘We very much commend the honourable Prince, our grandson the
honourable *infante* don Enrique, and the Duke of Segorbe his son, our
nephew’

Santa Cruz, Alonso de, *Crónica de los Reyes Católicos* (1491-1516)

The cases shown in (19) and (20) possibly correspond to the reflexive structure of the verb, and, consequently, *nos* should be interpreted as a reflexive. Under this analysis, in the cases in which *nos* refers to a group of persons, it does carry the offending [+Plural] feature and, as such, it poses a challenge to the NPBE because the non-dative is plural. However, in view of the example in (21), the *nos* in (19) and (20) may alternatively be analyzed as the subject of the verb, rather than as a reflexive. In addition, the fact that the same sequence is repeated in various texts of similar nature, it is also possible that “*nos os encomendamos*” is treated as a formulaic expression. In this case, these tokens may not be considered as representative of the productivity of clusters that violate the FMC. Thus, given the ambiguity of these examples and the possibility of them being tokens of a formulaic expression, they are not taken as strong evidence against the NPBE in OldSp.

In sum, the examples of *nos os*, *vos nos* and *nos vos* do not provide evidence against the NPBE and the FMC in OldSp. In most cases, the examples retrieved did not actually contain clusters that are subject to this restriction but

rather they were mostly cases of interpolation and combinations of a clitic and a stressed pronoun (both subject and object of a preposition). Very few cases are clear FMC contexts, such as (16), in which the non-dative clitic did not outrank the dative, thus complying with the restrictions. The three cases with *encomendar*, even though they may violate the NPBE and the FMC, are ambiguous and, possibly, either correspond to a fixed expression or the first clitic may be analyzed as a subject, which prevents them from being considered as strong evidence against the NPBE and FMC in this period.

3.2.2.3. Mixed combinations of singular and plural clitics

Te nos

Based on the NPBE, we would expect to find a considerable number of tokens for clitic clusters such as *te me* and *te nos*, in which the non-dative, in first position in the cluster, is singular. In section 3.2.2.1, we saw that *te me* is indeed present in the corpus, with a total of 724 tokens extracted. As was the case for *te me*, *te nos* is also present throughout the entire corpus (roughly between the years 1000 and 1974). Specifically, it appeared 72 times, with none of the occurrences constituting a violation of the NPBE.

It is interesting to note, however, that the combination *te nos* was far less common than *te me*, which points towards a preference for the cluster with two singular pronouns. However, this may not be surprising, given that both in the spoken language and in writing, singular tends to appear and be used more frequently than plural. In addition, it is worth noting that the contexts and types of texts included in the corpus may disfavour the presence of a cluster such as *te nos*. The texts from this corpus include legal documents, narrative, drama, and

poetry, amongst others. In general, when a second person is used in these documents, it tends to refer to individuals, rather than groups (e.g. a legal document consisting of a contract between two parties, a dialogue between two characters, etc.), hence the preference for singular pronouns. Thus, even though we find both types, singular pronouns outnumber plural ones in every search.

Nos te

The cluster *nos te* appeared 36 times. Again, as in the case of *nos (v)os* and *(v)os nos*, in 23 cases, *nos* is not an object pronoun but a subject pronoun. In five other cases, *nos* was the object of a preposition. Here are some examples:

- (22) **nos te** embiamos salud, honor y gloria y estado de caballero
 1.SG.NOM 2.SG.DAT send health honour and glory and status of knight
 ‘we (majest.) send you health, honour and glory, and the status of a knight’

Translation of *Tirant lo Blanch* by Joanot Martorell (1511)

- (23) Pues así de **nos te** debes servir que sienpre servir te podamos.
 This way of 1.SG 2.SG.REFL must serve that always serve 1.SG.DAT can
 ‘Thus you must make use of us (majest.), that we will always be able to help you’

Libro de los pensamientos variables (1485)

As we saw in the case of previously discussed combinations, none of the *nos te* examples belong to the type of clitic cluster that is subject to the FMC, and they do not constitute evidence against the hypothesis.

Os me

We have seen in Chapters 1 and 2 of this dissertation that the combination *os me* always corresponds to an ungrammatical sentence. Consequently, this combination would not be expected to appear in the corpus, as was the case for *os nos*. However, Andrés Bello, in his *Gramática de la lengua castellana* first published in 1847, notes that the cluster *os me* was used often until the 17th century. Indeed, *os me* appeared a total of 96 times in the corpus, the majority of which range between 1424 and 1650.

The presence of this cluster sharply contrasts with ModSp and challenges the idea that the NPBE and the FMC have been present throughout the different stages of the language. Even though there are at least five instances of *os me* that are not relevant for the study, the majority of the cases correspond to FMC contexts. Generally, these examples imply a construction with a dative of direction or an ethical dative, as is the case of (29) and (30), but there are also several cases with ditransitive verbs, as we can see in (31).

- (29) "¡Ah, don traidor!, ¿pensastes **os** **me** ir? Agora me
Ha mister traitor thought.2.SG. 2.SG.DAT 1.SG.DAT go? Now 1.SG.DAT
lo pagaréis."
3.SG.ACC pay.FUT
'Ha, Mr. Traitor, did you think you would get away from me? Now you will
pay for it.'

Villalón, Cristóbal de, *El Cróton de Cristóforo Gnofoso* (1553-1556)

(30) Marido y señor mío, ¿adónde **os** **me** llevan?

Husband and sir mine where 2.SG.DAT 1.SG.DAT take

‘My husband, and my lord, where are they taking you?’

Lazarillo de Tormes (1554)

(31) Pues porque Vos mismo **os** **me** distes en precio, ¿qué

Since because 1.Sg.Nom self 2.SG.ACC 1.SG.DAT gave in prize what

me queda para daros?

1.SG.DAT remains for give.2.SG.ACC

‘Since you gave yourself to me in payment, what do I have left to give you?’

Granada, Fray Luis de, *Manual de diversas oraciones y espirituales ejercicios* (1559)

At first sight, the presence of the combination *os me* in the corpus may seem a challenge for the FMC. A closer look at the examples shows that, in most cases, *os* is, in fact, not a plural clitic, but a singular one, since in a number of the contexts in which *os me* appears, *os* refers to a singular entity.

It is interesting to note that almost all tokens of *os me* date from the 16th century and the first half of the 17th century, with the exception of one late case by Francisco Garau in *El sabio instruido de la Gracia* (1703), reproduced below in (39).⁶⁹ This timeframe roughly corresponds to the period of competition between *tú* and *vos* as the non-deferential singular pronoun, and the eventual establishment of *tú* in this use (Penny 2002:138). In turn, the form *vosotros* gradually replaced *vos* in plural contexts and, when *tú* was retained as the non-deferential singular pronoun, the object clitic *os* remained as its plural counterpart. Finally, as we have seen in section 3.1.1, the pronouns that are retained as the deferential form of

⁶⁹ There is also a later case that dates between 1737 and 1789, but it is a reproduction of Garcilaso de la Vega’s *Soneto XIV*, which dates from 1526-1536.

address are *usted* and its plural counterpart *ustedes*, both of which derive from the deferential expression *vuestra merced/vuestras mercedes*.

This implies that, overall, *os me* was in use while *os* served as a 2nd person singular pronoun and, thus, when *os* specialized as a plural pronoun, the cluster *os me* ceased to be a valid combination and disappeared. However, there are up to 23 tokens in the corpus which may constitute a violation of the FMC. Out of these 23 cases, 5 of them were reproductions of earlier texts and 8 of them were ambiguous, either in the structure or in the possible referent for *os*. In one case, reproduced in (32), the cluster appears with the verb *dar*, in a context which is clearly subject to the FMC. In this case, the ambiguity lies in the fact that the cluster may be interpreted both as having the ACC-DAT and the DAT-ACC orders.⁷⁰ However, the context favours the ACC-DAT interpretation, in which case the example in (32) is compliant with the FMC, since the dative is not outranked by the non-dative.

- (32) a todos los hombres a quien falta la edad y experiencia (...) no
 to all the men to whom lacks the age and experience NEG
 podemos dar consejo, antes bien lo debemos recibir, pues para
 can give advice before well 3.SG.ACC must receive, since for
 esso **os** **me** ha dado mi padre.
 that 2.PL.DAT/ACC 1.SG.ACC/DAT has given my father
 ‘We cannot give advice to all those men who lack in age and experience,
 rather, we must receive it, since it is for that reason that my father gave me
 to you /you to me’

⁷⁰ The discussion of *me os*, below, includes a more detailed discussion on these two alternative orderings and their effects on FMC clusters.

*El sumario de lo que contiene la historia de la comedia del duque don Alonso y
desta cassa, y el ... (1535-1622)*

In 9 out of the 23 cases, *os* unambiguously corresponds to a non-dative plural clitic, which implies that all these examples violate the FMC. All the cases appear in texts that date between 1504 and 1657. In seven cases, reproduced below, the cluster appears with a pronominal verb (*mostrarse, volverse, detenerse, irse (x2), allegarse, llevarse*).

- (33) O dioses inmortales, (...) no **os** **me** mostréis aora contrarios
Oh gods immortal (...) NEG 2.PL.REFL 1.SG.DAT show now contrary
en esta batalla
in this battle
'Oh immortal gods, do not turn against me in this battle'

Ortúñez de Calahorra, Diego, *Espejo de príncipes y caballeros. [El caballero del Febo]* (1555)

- (34) Días cansados, duras horas tristes, (...) en años de pesar **os**
Days tired hard hours sad in years of sadness 2.PL.REF
me volvistes.
1.SG.DAT turned
'Tired days and hard, sad hours, you turned into sad years to me'

Hurtado de Mendoza, Diego, *Poesía* (c 1535 - 1575)

- (35) pues yo les digo, hermanos, (...) no **os** **me** detengáis
Then I 3.PL.DAT tell brothers NEG 2.PL.REFL 1.SG.DAT stop
'Then, I tell you (def., plural), my brothers, do not stop (on me)'

San Juan Bautista de la Concepción (Juan García Gómez), *Pláticas a los religiosos*

(c. 1603-1607)

(36) ¡Oh, benditas pajaricas, (...) no **os me** vais.

Oh holy birdies NEG 2.PL.REFL 1.SG.DAT go

‘Oh, holy little birds, (...) do not get away from me!’

López de Yanguas, Hernán, *Farsa de la concordia* (c. 1529)

(37) Con que os pueda goçar do **os me** fuistes

With that 2.PL.ACC can enjoy where 2.PL.REFL 1.SG.DAT went

‘So that I can enjoy you where you left me’

Poemas atribuidos a los Argensola [Poemas relacionados con los Argensola] (1628-

a. 1631)

(38) Venid acá, Pesares -dezia-, y no **os me** alleguéis muy cerca

Come here worries said and NEG 2.PL.REFL 1.SG.DAT come very close

‘Come here, worries -she said-, and do not get too close’

Gracián, Baltasar, *El Criticón, tercera parte. En el invierno de la vejez* (1657)

(39) Pues es bueno, replicó Micas, que **os me** llevais mis Dioses

Since is good replied Micas that 2.PL.REFL 1.SG.DAT take my gods

con el Sacerdote, y con todo

with the priest and with all

‘Since it is good -replied Micas- that you take my gods away from me, including the priest and everything’

Garau, Francisco, *El sabio instruido de la Gracia* (1703)

In the two remaining cases, the cluster *os me* appears as a result of clitic climbing, as shown in the following examples:

(40) "¡O, hijos míos, doy yo gracias al Alto Señor que en fin de mi
 Oh sons mine give I thanks to-the high lord that in end of my
 vejez **os** **me** dexó ver!
 old age 2.PL.ACC 1.SG.DAT let.PAST see
 ‘Oh, children of mine, I praise the Great Lord, who finally let me see you in
 my old years’

Silva, Feliciano de, *Lisuarte de Grecia* (1514)

(41) Mis buenos amigos, (...) a Dios doy yo muchas gracias que **os**
 My good friends to god give I many thanks that 2.PL.ACC
me dexó ver
 1.SG.DAT let see

‘My good friends, I thank God greatly because He let me see you’

Ortúñez de Calahorra, Diego, *Espejo de príncipes y caballeros*. [*El caballero del Febo*] (1555)

As we can see in the previous examples, these cases in which the non-dative outranks the dative appear with a variety of verbs and in a variety of texts of different types and from different authors. However, if we look at the syntactic structure, we can see that the majority of cases occur in a combination of a reflexive and a dative. In view of this, we may argue that the REF-DAT cluster has not always been subject to the FMC. Crucially, Bianchi (2006) argues for Italian that inherent reflexives, as well as ethical datives, are not subject to the PCC. Then, by extension, it may be argued that these constructions are not subject to

the FMC, either.⁷¹ However, there are also examples of non-reflexive and argumental dative plural clitics, such as (40) and (41), which suggest that, while there clearly seems to be a bias towards clusters containing reflexives and ethical datives, the apparent violations of the FMC in this period are not exclusive to these structures.

Me os

The cluster *me os* was present in the corpus even though this combination is not possible in ModSp. Specifically, it appeared 26 times, out of which 20 were relevant to the study. Two of these examples are presented in (42) and (43).

(42) ¿Para qué los dioses **me os** dieron por padre y a vosotros

For what the gods 1.SG.ACC 2.PL.DAT gave for father and you.DAT

a mí por hijos?

me.ACC for sons

‘Why did the gods give me to you as your father and you to me as my children?’

Baldo (1542)

(43) Amiga, ¿es éste el cavallero que **me os** embió?

Friend is this the knight that 1.SG.DAT 2.SG.ACC sent

‘My friend, is this the knight that sent you to me?’

Primaleón (1512)

Before we move on to the analysis of this cluster, it is important to note that, as was the case for previously discussed combinations, *me os* is not possible

⁷¹ As discussed in Chapter 2, this is not the case, at least for ModSp, since constructions with reflexives and ethical datives do show the combinatorial restrictions predicted by the FMC.

in ModSp. Let us recall that Perlmutter (1971) argues that clitics in ModSp are arranged by person and that the specific order in which clitics appear in Spanish is the following:

(44) $se > 2 > 1 > 3$

In general, all combinations of clitics are arranged according to this order.⁷² The combination *me os*, as we can see, does not respect the order and, consequently, it is not possible in ModSp. However, the data from the corpus seems to prove that this order did not apply in all stages of Spanish and, as such, we have found several examples of clusters in which 1st person precedes 2nd, as we can see in examples (42) and (43).⁷³

In the examples of *me os* extracted from the corpus we can see both the ACC-DAT (or ILLUM-MIHI) order, which was the standard in Old Romance languages, and the DAT-ACC (or MIHI-ILLUM) order, which corresponds to the ModSp order of 3rd person clitics, as discussed in Chapters 1 and 2. It is during the 16th and 17th centuries that the shift from ACC-DAT to DAT-ACC took place in a number of languages including Spanish (Wanner 1999: 261). After this period, Spanish sets the ordering of its clitics by person, following Perlmutter's template reproduced in (44), and, within this template, DAT-ACC is preferred over ACC-DAT in the case of 3rd person clusters.

We have also seen that the ACC-DAT order is also present in *os me* combinations, which seems to indicate that the ordering of clitics by case had

⁷² There are some cases in ModSp that follow this order and, yet, they are not acceptable. Among other cases, we find that a non-reflexive pronoun cannot precede a reflexive one (see Fernández Soriano 1999 for further discussion on this issue).

⁷³ This is also the case for examples of *nos vos* such as (19) and (20) above, where *nos vos* appears with the verb *encomendar*.

preference over the ordering by person, hence the presence in the corpus of both *me os* and *os me* in comparable structures and in the same time range, as shown in (32) and (42). The opposite situation is found in ModSp, where ordering by person takes preference and, as such, *me os* is not possible in ModSp due to both the violation of the FMC and the unacceptable 1st > 2nd sequence.

Therefore, the data presented in these sections is consistent with the idea that the fixed linear order of clitics found in ModSp, i.e. the 2nd > 1st sequence, does not apply throughout the history of Spanish. In other words, the data show that there have been diachronic changes regarding the arrangement of clitics in a sentence, both with respect to other elements in the structure, as seen in section 3.1.2, and within the cluster. Crucially, most of the *me os* examples occur between the second half of the 15th century and the first half of the 17th century, and no cases of *me os* are found after 1652. Let us recall that it is precisely around the 15th century that scholars place the change from OldSp to ModSp. Thus, it seems that the order proposed by Perlmutter is settling into the language during this period.

It is interesting to note, however, that the combination *me os* does respect the FMC for the most part. In the case of (42), for example, *os* is plural, but it does not constitute a violation of the FMC, because the order is ACC-DAT and, as such, the plural pronoun is the dative, so the cluster is in fact compliant with the restriction. The sentence in (43) is also compliant, since both clitics have a singular referent. The only case that may constitute a violation of the FMC is reproduced in (45).

(45) Llanto tengo en que **me os** bañéis,
 Crying have.1.SG in that 1.SG.DAT 2.PL.REFL bathe
 cabellos, para limpiaros
 hairs to clean.2.PL.ACC
 'I am in tears to bathe you, my hairs, to clean you'

El lego del Carmen. San Franco de Sena (1652)

This example is rather difficult to interpret, although the structure of the sentence points towards an analysis of the cluster as DAT-REF, in which case, the non-dative outranks the dative, and consequently, the sentence violates the FMC. However, the fact that this is an isolated and rather obscure example and that it appears in a theatre play written in verse may imply an artificially created structure.

In sum, with the possible exception of the sentence in (45), the cases of *me os* retrieved by the search engine did not contain examples that violated the FMC.

Vos me

The corpus contains 1675 cases of *vos me*. As was the case for *vos nos*, most of the cases are combinations of a stressed and an unstressed pronoun, which correspond to structures that are not subject to the NPBE and the FMC. Specifically, most of the cases (1174 cases) have *vos* as the subject of the sentence, or as an object of a preposition (492 cases). There are 9 ambiguous cases, one of which is possibly an FMC example. This example is reproduced in (46).

(46) Heme aquí, do **vos** **me** arrimo
 Have.1.SG.ACC here where 2.SG.DAT 1.SG.REFL come-close
 ‘Here I am, where I get close to you’

Comedia Rosabella (1550)

This example is part of a dialogue between two characters and, in this case, as well as in the other ambiguous cases, *os* refers to a singular entity, so none of the *vos me* cases constitute a violation of the FMC.

Me vos

The cluster *me vos* appeared a total of 279 times in the corpus. As in the case of *vos me*, in most instances (211 cases), *vos* was a subject pronoun, as shown in (47). As in numerous examples of *nos vos*, these are cases of interpolation and, therefore, they are not subject to the FMC.

(47) seria muy graue del dar respuesta a todas preguntas que **me**
 Be.Cond very grave of.to give answer to all questions that 1.SG.DAT
vos feziestes.
 2.SG.NOM made

‘It would be very bad to give answer to all the questions you asked me’

Manuel, Juan, *Libro del caballero y del escudero* (1326)

Me vos also appears in 68 potential FMC contexts, including 8 cases with the verb *encomendar*. Out of the 68 examples, 4 were ambiguous, although the referent for *vos* was singular in all four cases. The remaining 64 cases, including the 8 contexts with *encomendar*, are all compliant with the FMC, since they either

follow the ACC-DAT order, in which case the non-dative is always singular, or they follow the DAT-ACC order and *vos* refers to a singular entity, as shown in (48).

- (48) Esperad, que no **me vos** podréis escapar
Wait that NEG 1.SG.DAT 2.SG.REFL can.Fut escape
'Wait, because you will not be able to escape from me'

Primaleón (1512)

As in previous cases, none of the examples in *me vos* constitute a clear violation of the FMC.

3.3. CONCLUSIONS FROM THE DIACHRONIC DATA

The data from ModSp presented in Chapter 2 showed that the [Plural] feature has an effect in clitic clusters and that they are subject to the NPBE and the FMC. The diachronic data, on the contrary, are less straight-forward. The overwhelming majority of the cases extracted from CORDE do not imply a violation of the FMC, since they are not clitic clusters of the type that is subject to this restriction. These cases include tokens in which the first element is a subject pronoun or an object of a preposition, and also cases of interpolation. In addition, there are instances of clitic clusters which do not comply with the ordering rules of ModSp clitics (i.e. the cases of *me os*) but which, nevertheless, comply with the FMC.

However, there are some cases that seem to violate the FMC and their presence initially challenges the idea that this restriction has been active throughout the different stages of Spanish. All the examples appear in various types of texts, from different authors and with various constructions. However, it is

important to bear in mind that the number of cases that challenge the FMC is rather low. Out of all the analyzed cases, there are only nine clear examples of clitic combinations that challenge the FMC, all of which appear with the cluster *os me*. These cases seem to be closely, but not exclusively, related to clusters containing reflexives as well as datives of direction and ethical datives. There are also some potential violations of the constraint in three cases of *nos vos* with the verb *encomendar* and one case with *me os*. This makes a total of 11 likely violations of the FMC, all of which date between the early 16th century and mid 17th century.

Besides the presence of these challenging examples, the timeframe in which they appear, the 16th and 17th centuries, is very relevant. We have seen that many of the examples which violate Perlmutter's order also occur in this period. Thus, the two alternative forms *me os* and *os me* co-occur during the 16th and 17th centuries. Crucially, this time frame corresponds to the period immediately after the change of status of Spanish clitics.⁷⁴ At the same time, the shift from the standard Old Romance ACC-DAT to DAT-ACC has also been argued to have taken place in the 16th and 17th centuries.⁷⁵

Thus, it seems that this period is a time of readjustment in the language and, consequently, fluctuations and variability are likely to occur. In this light, the fact that the only examples that challenge the FMC appear within the specific timeframe in which all these changes are taking place seems anything but coincidental. Furthermore, we may consider that the violations of the FMC are indeed an effect of these readjustments of the language.

⁷⁴ Let us recall that this change is assumed to have taken place around the 15th century.

⁷⁵ For a brief discussion on the different ordering patterns that have resulted in Modern Romance, see Chapter 1 (pages 5-6).

As indicated above, *os me* appears between the 15th and 17th centuries and, during this time, the cluster is in competition with *me os*. In fact, this competition may be taken as evidence for the introduction of Perlmutter's order or, in more general terms, the preference to order clitics by person, rather than by case. Along these lines, we may even consider the possibility that the plural *os me* cases are actually instances of over-regularization of the new ordering of clitics that requires 1st person to follow 2nd person.⁷⁶

In a nutshell, despite the presence of some counterexamples, the diachronic data show that there is a very strong tendency in Spanish to reject the presence of a plural non-dative clitic in a cluster, and this tendency can be documented in previous stages of the language.

In the next two chapters, I present experimental data from two experiments, a scaled grammaticality judgment task and an on-line self-paced reading task, administered to four groups of speakers of Spanish: one group of native speakers of Peninsular Spanish and three groups of L2 speakers. The data from these chapters will provide valuable information on the native and non-native speakers' attitude towards clitic clusters in an attempt to contribute to a better understanding of clitic phenomena, not only from a descriptive point of view, but also with respect to their perception and processing.

⁷⁶ By over-regularization I mean the systematic placement of a 2nd person in front of a 1st person, regardless of whether the clitics are singular or plural. In other words, it seems like these examples show an attempt to systematize Perlmutter's order to the extent of producing sentences not favoured by the language, which are those cases in which the first clitic of the cluster is plural.

4. GRAMMATICAL AND PROCESSING STATUS OF CLITIC CLUSTERS IN NATIVE SPANISH

It has been discussed in previous chapters of this dissertation that the motivations and mechanisms that trigger clitic cluster restrictions have been subject to a great deal of attention in the linguistic literature. However, this discussion has focused mainly on theoretical issues and the different accounts for these phenomena have remained within linguistic theory. In other words, there is an absence of experimental studies that deal with clitic restrictions, and few experimental data are available to provide further understanding of clitic phenomena.

The evolution of clitic clusters and clitic cluster constraints through time has not previously been explored and, as such, the study presented in Chapter 3 constitutes a novel approach to the analysis of these issues. In addition to the diachronic perspective and the introduction of the notion of language change, two other aspects remain largely unexplored in the study of clitic phenomena, namely

native speakers' perception of different clitic combinations, both acceptable and unacceptable, and non-native acquisition of such combinations.

By investigating the perception of clitic combinations by different groups of speakers we may gain insight into the mental representation of these structures and, in relation to this, we may learn more about whether these clitic restrictions can be related to underlying processing constraints, given that they have been identified in a number of languages and that they seem to have a common set of characteristics, which were expressed as the Feature Markedness Constraint (FMC) in Chapter 2. In fact, the connection between clitic restrictions and language processing is yet another issue that has not been explored in the literature, so pursuing these lines of investigation may contribute to a better understanding of a number of points identified by the theory. In this spirit, and following the trend set in Chapter 3, Chapters 4 and 5 tap into these little-explored aspects and provide novel data to the study of clitic phenomena in Spanish. Specifically, these chapters present two experiments, a scaled grammaticality judgment task and an on-line self-paced reading task, administered to both native speakers (Chapter 4) and advanced learners of Spanish whose L1s are English, French and Romanian (Chapter 5). In sum, the analysis of the experimental data obtained from these experiments contributes to the study of Spanish clitic restrictions and opens new paths of investigation by providing insight on the speakers' perception and processing of these structures as well as on learnability issues that may arise during the acquisition of Spanish clitic cluster constraints by non-native speakers.

Clitic cluster constraints and experimental data

The theoretical guidelines for the experimental research presented in this dissertation are summarized in the Feature Markedness Constraint, presented in Chapter 2 and reproduced here in (1).

- (1) A. In a combination of clitics, a dative clitic cannot be outranked in terms of marked features by a non-dative clitic.
- B. The acceptability of two clitics that contain equally marked features is language-specific.

Crosslinguistically, the FMC predicts significant rejection of any clitic combination in which the non-dative outranks the dative, which is consistent with the observations presented in Chapter 2. In addition, as discussed in Chapters 2 and 3, part B of the FMC in the case of Spanish takes the form of the Narrow Plural-Blocking Effect (Alba de la Fuente, 2010), henceforth NPBE, which is reproduced here in (2):

- (2) In a combination of 1st and 2nd person clitics with a dative, the non-dative cannot be plural.

Thus, based on the predictions made by the FMC and the NPBE, combinations of 1st and 2nd person clitics in which the non-dative element is plural are expected to be strongly rejected in Spanish. This is supported by the data and findings discussed in Chapters 2 and 3.

In addition to feature markedness, several authors point out that syntax has an effect on clitic combination restrictions. However, as mentioned in Chapter 2,

despite the fact that syntax-based models such as Anagnostopoulou (2005) and Bianchi (2006) are able to account for much of the clitic phenomena discussed in the chapter, two crucial aspects regarding the relationship between the syntactic structure and the acceptance of clitic clusters still seem to elude explanation: 1) the fact that not only argumental but also non-argumental datives display the same restrictions, and 2) the apparent preference for 1st/2nd REFL-DAT combinations over 1st/2nd ACC-DAT.⁷⁷ In fact, the reasons why some structures are subject to clitic restrictions whereas others are not, as well as the distribution of clitic restrictions across different structures, is a contentious issue and there are hardly any experimental data available on clitic restrictions that may lead to a better understanding of these phenomena.

Finally, one last aspect that has not been explored in studies regarding clitic clusters in Romance is whether there is a connection between the acceptability patterns of clitic clusters and language processing or, more specifically, whether certain language processing limitations may be related to the acceptance or rejection of a given cluster.

Thus, taking all this into account, this chapter presents two experiments designed to address the following general research questions:

I. Whether the perception of clitic clusters by native speakers of Spanish patterns with the restrictions stipulated by the FMC and the NPBE or, in other words, whether the FMC and the NPBE successfully predict the acceptability patterns displayed by native speakers of Spanish.

⁷⁷ See page 70 (section 2.4.2) of this dissertation.

II. Whether experimental data will provide us with valuable information that may help us determine the effects of the syntactic structure on clitic restrictions and provide us with a better understanding of how syntax and morphology interact in these contexts.

III. Whether the restrictions expressed in clitic cluster constraints, specifically the FMC and the NBPE, can be related to processing constraints.

In order to address these general research questions, section 4.1 presents a scaled grammaticality judgment task and section 4.2 presents an on-line self-paced reading task, both administered to native speakers of peninsular Spanish.

4.1. SCALED GRAMMATICALITY JUDGMENT TASK

As discussed above, there is a significant lack of experimental studies on clitic combination restrictions. In fact, to the best of my knowledge, the only study that includes experimental data and discusses the perception of clitic clusters in Romance is Nevins and Săvescu (2010), which discusses native perception of various clitic clusters in Romanian. In their paper, the authors note that there is an asymmetry between combinations of 1st and 2nd person clitics when it comes to singular and plural in Romanian.⁷⁸ In order to further explore the effects of the [Plural] feature in these clusters, Nevins and Săvescu (2010) carried out a study on the acceptance of 1st and 2nd person combinations which included both singular and plural clitics. Specifically, they administered an acceptability judgment task to 17 native speakers of Romanian in order to determine the acceptability patterns of

⁷⁸ This asymmetry identified by Nevins and Săvescu is, in fact, parallel to the one found in Spanish and it largely corresponds to the phenomena associated with the FMC. For further details, see Chapters 1 and 2 of this dissertation.

these clusters in gerund constructions. The combinations included in the test, as reported by the authors, are reproduced in (3).

(3) Dându **mi te** (1SG/2SG)

Dându **ți mă** (2SG /1PL)

Dându **ni vă** (1PL/2PL)

Dându **vi ne** (2PL/1PL)

Dându **mi vă** (1SG/2PL)

Dându **ți ne** (2SG/1PL)

The results of the task show significantly more rejection when the Direct Object clitic (DO) is plural, which is consistent with the FMC. Table 4.1, below, includes the breakdown of the results reported by Nevins and Săvescu.⁷⁹

Table 4.1. Acceptability judgment task results

NUMBER	PERSON	MEAN RATING	ST. DEV
SG/SG	1/2	4.91	0.36
SG/SG	2/1	4.09	1.73
SG/PL	1/2	3.65	1.91
SG/PL	2/1	3.44	2.10
PL/PL	1/2	2.97	2.12
PL/PL	2/1	2.18	2.02

[Adapted from Nevins and Săvescu 2010:189]

The authors also report that the statistical analysis conducted by means of an Analysis of Variance (ANOVA) revealed a significant effect for number ($F(2,96)=9.546$, $p < 0.001$) but not for person ($F(1,96)=2.850$, $p > 0.09$) or for the number-person interaction ($F(1,96)=0.312$, $p > 0.74$). Specifically, the authors

⁷⁹ The ratings correspond to a 5-point Likert scale where 5 corresponds to “completely acceptable” and 1 corresponds to “completely unacceptable”.

explain that “the presence of plural 1st or 2nd person clitic, in particular in DO position, is the stronger factor affecting acceptability of Postverbal Clusters” (Nevins and Săvescu 2010:189). Crucially, these results are compatible with the FMC and the NBPE, since the participants show significantly higher rejection for clusters in which the non-dative clitic is plural, which is exactly what these restrictions predict.

In sum, the predictions made by the FMC and the PBE are confirmed by both the data presented in Chapters 2 and 3 and Nevins and Săvescu’s (2010) study of Romanian clusters. However, there are no available experimental studies dealing with clitic clusters in Spanish and, thus, the scaled grammaticality judgment task presented below aims to fill this gap.

This study

In order to test the perception of 1st and 2nd person clitic combinations, a scaled grammaticality judgment task was distributed to native speakers of Peninsular Spanish. The choice of speakers of Peninsular Spanish was motivated by the fact that this variant makes regular use of the form *vosotros* and *os*, in contrast with Latin American variants of Spanish, which replace the forms *vosotros* and *os* by *ustedes* and *se*, respectively. This difference is crucial because, as we have seen in Chapter 2 (section 2.3), *se* is underspecified for both person and number and, therefore, sentences using *usted/se* instead of *vosotros/os* are not affected by the FMC and the NPBE.

4.1.1 Research Questions

This experiment aims to answer the following research question: When it comes to the perception of 1st and 2nd person clitic combinations, will the judgments provided by native speakers of Spanish coincide with the predictions made by the FMC and the NPBE? In other words, will native speakers of Spanish reject clitic combinations in which the non-dative is plural and accept combinations in which the non-dative is singular?

4.1.2 Hypotheses

As we have seen at the beginning of section 4.1, the results of Nevins and Săvescu's (2010) experiment show significantly higher rejection for clusters in which the non-dative clitic is plural, as predicted by the FMC and the NPBE. In view of these results, the Spanish data are expected to show a similar trend, namely that native speakers of Spanish show acceptance and rejection patterns that align with the above mentioned clitic restrictions. Specifically, the participants of this grammaticality judgment task are expected to accept clitic combinations in which the non-dative is singular and reject those in which the non-dative is plural.

4.1.3 Experimental design and materials

There were three types of items in the experiment—experimental, control and fillers—, and there were 32 items of each type, making a total of 96 sentences in the experiment. Table 4.2 presents a breakdown of the items included in the experiment.

- c) Tú **te** **me** enfermas
 You 2.SG.REFL 1.SG.NAD get.sick
 ‘You get sick (and I’m affected by it)’
- d) Tú **te** **me** presentaste
 You 2.SG.REFL 1.SG.DAT introduced
 ‘You introduced yourself to me’

There were eight items for each of the four structures, which made a total of 32 experimental items. All experimental items contained a 1st and 2nd person cluster that was manipulated with respect to number, thus producing a total of four conditions, reproduced in (5).

- (5) A. **te me** [2SG 1SG]
 B. **te nos** [2SG 1PL]
 C. ***os nos** [2PL 1PL]
 D. ***os me** [2PL 1SG]

Based on Perlmutter’s order, these four conditions correspond to the only potentially acceptable combinations of 1st and 2nd person in Spanish, since they respect the ordering template according to which 2nd person must always precede 1st person.⁸² However, only the first two clusters are actually grammatical in Spanish. In addition to the ordering preference, combinations of 1st and 2nd person clitic clusters follow the ACC-DAT pattern in Spanish, as discussed in Chapter 1. According to this preference, conditions A and B contain a singular non-dative

⁸² For further discussion, see the discussion on Perlmutter’s ordering template of Spanish clitics in Chapters 1, 2 and 3 of this dissertation.

clitic, whereas conditions C and D both contain a non-dative clitic that is plural, which is banned by the NBPE.⁸³ Consequently, only conditions A and B are acceptable according to both linear ordering constraints and the NBPE.

In addition to the experimental items, the task also included 32 control items which contained combinations with 3rd person clitics in the four structures illustrated in (4). Sample control items are presented in (6).

- (6) a) Le preparas verduras y no **te las** come.
 3.SG.DAT prepare vegetables and NEG 2.SG.NAD 3.SG.ACC eat
 ‘You cook him vegetables and he doesn’t eat them’ [NAD-ACC]
- b) **Nos le** han robado la moto esta mañana.
 1.PL.NAD 3.SG.DAT have stolen the bike this morning
 ‘They stole his bike this morning’ [DAT-NAD]
- c) Entonces ella **se me** puso a llorar.
 Then she 3.SG.REFL 1.SG.NAD put to cry
 ‘Then she started crying on me’ [REFL-NAD]
- d) **Se nos** quemó el plato principal
 3.SG.REFL 1.PL.DAT burned the dish principal [REFL-DAT]
 ‘The main dish burned (we accidentally burned the main dish)’

These control items were added in order to assess whether the participants accepted these structure types with combinations other than 1st and 2nd person. Finally, the experiment was completed with 32 fillers, which included sentences containing clitics and other pronouns whose structures were unrelated to the

⁸³ This is true for the ACC-NAD, REFL-NAD and REFL-DAT structures. See footnote 81 with respect to the DAT-NAD structure type.

study, such as quirky subjects and regular ditransitives.⁸⁴ Sample filler items are presented in (7).

- (7) a) A él le gusta mucho el tenis [Quirky subject]
To him 3.SG.DAT like much the tennis
'He likes tennis very much'
- b) Tienes que decírselo [Ditransitive]
have that tell.3.SG.DAT.3.SG.ACC
'You have to tell (it to) him'

The four conditions and the four syntactic structures of the experimental items were distributed into four lists and randomized using a Latin Square design. Thus, each participant saw only one condition of each item and all items were seen only once. The controls and the distractors were the same in all lists. In the case of the control and filler items, there were two conditions, one grammatical and one ungrammatical, which were evenly distributed across the four lists in order to make sure that each participant saw only one condition of each item and that the number of grammatical and ungrammatical items was balanced in each list as well as across lists. All items were controlled for length and complexity of vocabulary.

All the items in the experiment had the same format and structure: first, a sentence which set up the context, then the target sentence containing the cluster and, finally, the 5-point Likert scale used to rate the target sentence. Here follows a sample experimental item set with all four conditions.^{85, 86}

⁸⁴ Filler items were included to distract the participants' attention from the experimental items. Similarly, all items (experimental, control and fillers) contained clitics in order to conceal the experimental items as much as possible.

⁸⁵ A sample set of experimental, control and filler items used in this task can be found in Appendix B.

(8) a) Vamos, entra en casa y espera a Martina en el salón...

‘Come on, get in and wait for Martina in the living room...

...que **te me** vas a enfermar si sigues esperándola ahí, en la calle.

...you are going to get sick (on me) if you keep waiting for her out there, on the street.’

1	3	5	7	9
completely unacceptable sounds strange	relatively unacceptable but not completely	uncertain cannot decide	relatively acceptable but not as good as (9)	completely acceptable

b) Vamos, entra en casa y espera a Martina en el salón...

‘Come on, get in and wait for Martina in the living room...

...que **te nos** vas a enfermar si sigues esperándola ahí, en la calle.

...you are going to get sick (on us) if you keep waiting for her out there, on the street.’

1	3	5	7	9
completely unacceptable sounds strange	relatively unacceptable but not completely	uncertain cannot decide	relatively acceptable but not as good as (9)	completely acceptable

c) Vamos, entrad en casa y esperad a Martina en el salón...

‘Come on, get in and wait for Martina in the living room...

...que **os nos** vais a enfermar si seguís esperándola ahí, en la calle.

...you are going to get sick (on us) if you keep waiting for her out there, on the street.’

1	3	5	7	9
completely unacceptable sounds strange	relatively unacceptable but not completely	uncertain cannot decide	relatively acceptable but not as good as (9)	completely acceptable

⁸⁶ Even though there were five points in the scale, the actual values were 1, 3, 5, 7 and 9, in order to increase the distance between the lowest and highest points.

d) Vamos, entrad en casa y esperad a Martina en el salón...

‘Come on, get in and wait for Martina in the living room...

...que **os me** vais a enfermar si seguís esperándola ahí, en la calle.

...you are going to get sick (on me) if you keep waiting for her out there, on the street.’

1	3	5	7	9
completely unacceptable sounds strange	relatively unacceptable but not completely	uncertain cannot decide	relatively acceptable but not as good as (9)	completely acceptable

The experiment also contained four practice items at the beginning in order to help the participants get used to the characteristics of the experiment.⁸⁷

4.1.4 Procedure

Participants were instructed to read the context sentence, then the target sentence and, finally, they were asked to rate the target sentence with one of the values of the 5-point scale provided at the end of each item. For the sentences that were judged to sound bad, participants were also asked to highlight the part which they considered was wrong. This instruction was included in order to confirm that the negative judgments were caused by the clitic cluster and not by an unrelated element in the sentence, such as a vocabulary item. Participants were not asked to provide a correction for these sentences so that they would not alter their judgments and modify their original rating to a neutral or high value if they were unable to find a satisfactory correction for the sentence. In addition to the task,

⁸⁷ Practice items included both correct and incorrect sentences such as *Por ejemplo, muchos vuelos han sido cancelados* (‘For example, many flights have been cancelled’) and **Por eso, ahora pasa mis veranos en un centro de hípica* (‘That’s why he spends my summers in a riding club’).

participants were asked to complete a language background questionnaire. The complete experiment took, on average, 45 to 50 minutes to complete.

4.1.5 Participants

A group of 24 native speakers of Peninsular Spanish participated in the experiment. All participants were adult speakers residing in Spain at the time of the experiment. In the language background questionnaire, all participants reported having some knowledge of other languages, mainly English (20) and French (13). Other languages that the participants spoke included: German (3), Catalan (3), Galician (2) and Italian (2).⁸⁸ All the participants confirmed that their dominant language was Spanish, which was also the language they used most regularly and the one with which they were most comfortable at the time of testing. The mean age for the group was 35.6 years, with ages ranging from 18 to 57, and there were 16 female and 8 male participants.

4.1.6 Results and discussion

As indicated in the *Hypotheses* section, the participants of this task were expected to show acceptance and rejection patterns of the clitic clusters consistent with the FMC and, as such, sentences in which the non-dative is plural were expected to be rejected across the board. This section presents the results of the scaled grammaticality judgment (GJ) task.⁸⁹

⁸⁸ Given the impossibility to find a representative number of pure monolingual speakers who have never been exposed to any language other than Spanish, exposure to other languages was not considered a parameter for participant exclusion as long as the native and dominant language was Spanish.

⁸⁹ Only the results of the experimental items will be reported and discussed throughout this section.

Table 4.3. Total mean ratings (experimental items)

CLUSTER	MEAN	ST. DEV.
<i>te me</i>	3.33	1.51
<i>te nos</i>	3.16	1.63
<i>os nos</i>	1.32	0.519
<i>os me</i>	1.11	0.353

Table 4.3, above, provides the mean and standard deviation values for each cluster and Figure 4.1, below, shows the overall results from the experimental items with respect to cluster type, according to the data reported on Table 4.3.

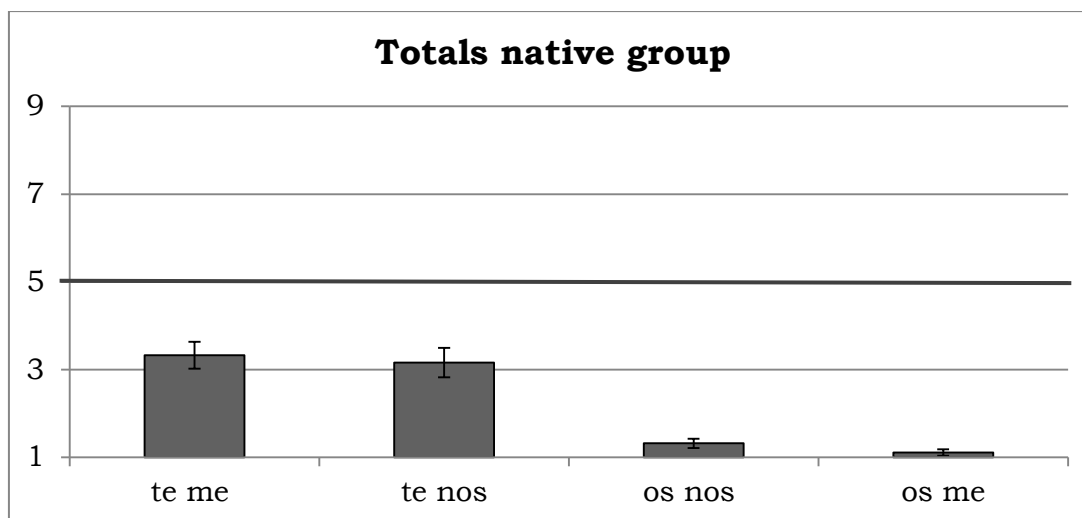

Figure 4.1. Total average results from the native group by cluster type⁹⁰

As we can see in Table 4.3 and Figure 4.1, and contrary to expected, the overall ratings for all cluster types, both grammatical and ungrammatical, were quite low.⁹¹ In fact, none of the clusters reach the midpoint value, which

⁹⁰ All the figures in this chapter include error bars calculated using standard error.

⁹¹ For the remainder of the thesis, cluster types that comply with the NPBE, i.e. those with a singular non-dative, will be referred to as grammatical clusters and those that violate the NPBE, i.e. clusters with a plural non-dative clitic, will be referred to as ungrammatical clusters.

corresponds to 5. This was expected for *os nos* and *os me*, since they are ungrammatical according to the NPBE, but not for *te me* and *te nos*, which follow the adequate linear ordering (2nd person before 1st person, ACC before DAT) and also comply with the NPBE.

In order to verify whether the differences found in the data were statistically significant, a 4x4 repeated measures Analysis of Variance (ANOVA) with Structure (ACC-NAD, DAT-NAD, REFL-NAD and REFL-DAT) and Cluster (“te me”, “te nos”, “os nos” and “os me”) as the within-subjects factors was performed on these data. The results of the ANOVA reveal a main effect for Structure ($F(3,69)=54.400$, $p<.001$), as well as a main effect for Cluster ($F(3,69)=40.463$, $p<.001$) and a significant interaction between the Structure and Cluster factors ($F(9,207)=22.175$, $p<.001$).

With respect to Cluster, the results of the ANOVA indicate that the differences between the grammatical and ungrammatical clusters are significant. In other words, despite the low overall rates for all the conditions, the rates for the ungrammatical clusters are significantly lower than those for the grammatical clusters. Specifically, pairwise comparisons using the Bonferroni correction reveal significant differences between the following pairs of clusters: *te me* and *os nos* ($p<.001$), *te me* and *os me* ($p<.001$), *te nos* and *os nos* ($p<.001$) and *te nos* and *os me* ($p<.001$).

In this respect, the results are robust in that they show a preference for clusters that are predicted to be acceptable by the NPBE and, at the same time, they show a very strong rejection for combinations that violate the restriction. This is supported by the results of the statistical analysis, since the differences between

grammatical and ungrammatical clusters are statistically significant. In consequence, and despite the low overall ratings, the hypothesis that the FMC and the NPBE are able to predict the acceptability patterns of clitic combinations in Spanish is confirmed.

With respect to the low overall ratings for the grammatical conditions, a number of possible explanations may account for these unexpected results. First, three out of the four structures included in the design contain a non-argumental dative (NAD), which is typical of oral speech. Given that it was a written task, some participants may have based their judgments on the fact that structures with NADs are uncommon, or even unnatural, in written form. In this respect, the low overall ratings may be an effect of the task itself. In addition, as the results of the ANOVA indicate, not all structure types were rated the same way, so averaging the results across structure types caused a cancelling effect in the overall results. Furthermore, averaging across participants created a similar effect, since some participants gave consistently higher rates and others gave consistently lower rates. In this respect, we have a group of “high raters” and a group of “low raters” that balance each other out in the total results. This issue will be further discussed at the end of this section.

Let us now consider the results of the different syntactic structures included in the experimental design. As indicated above, the results of the ANOVA reveal a main effect for Structure ($F(3,69)=54.400$, $p<.001$), which means that not all structures were rated the same way. Furthermore, when we break down the results by structure type, a new picture emerges with respect to the acceptability patterns of grammatical and ungrammatical clusters.

Table 4.4. Total ratings from the native group by structure type

CLUSTER	ACC-NAD		DAT-NAD		REFL-NAD		REFL-DAT	
	MEAN	ST. DEV	MEAN	ST. DEV	MEAN	ST. DEV	MEAN	ST. DEV
<i>te me</i>	1.79	1.532	1.38	0.77	4.63	2.499	5.54	2.57
<i>te nos</i>	1.75	1.391	1.42	0.929	4.33	2.697	5.12	2.643
<i>os nos</i>	1	0	1	0	1.58	1.176	1.71	1.334
<i>os me</i>	1	0	1.13	0.612	1.08	0.408	1.25	1.032

Table 4.4, above, and Figure 4.2, below, show the breakdown of the results by structure type as well as by cluster type.

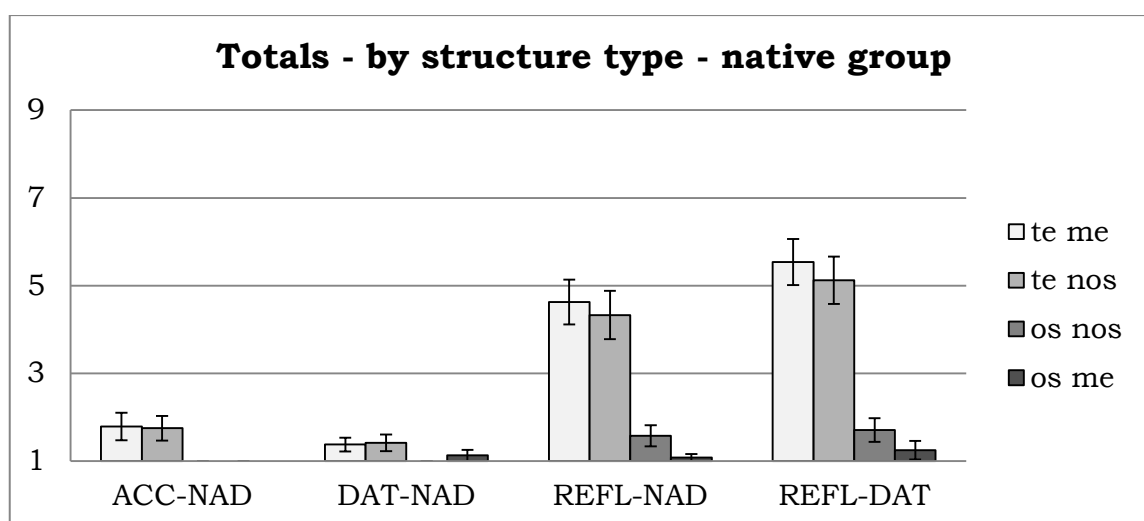

Figure 4.2. Total average results from the native group by structure type

As we can see in Figure 4.2 and Table 4.4, there are clear differences between the ACC-NAD and the DAT-NAD structures on the one hand, and the REFL-NAD and the REFL-DAT structures on the other. Specifically, the grammatical clusters received much higher rates in the two structure types that include a reflexive, whereas the rates for the ungrammatical clusters remain very low in all four structure types. These observations were supported by the statistical analysis, as pairwise comparisons using the Bonferroni correction reveal

significant differences between the following pairs of structures: ACC-NAD and REFL-NAD ($p<.001$), ACC-NAD and REFL-DAT ($p<.001$), DAT-NAD and REFL-NAD ($p<.001$), DAT-NAD and REFL-DAT ($p<.001$).

In view of these results, the pattern predicted by the NPBE is also confirmed for each structure type. As such, for all four structure types, conditions in which the non-dative was plural (ungrammatical conditions) were very strongly rejected and, in turn, conditions in which the non-dative is singular (grammatical conditions) were much more readily accepted in structures including a reflexive.

In the case of the ACC-NAD structure, reproduced in (9), the overall acceptance of this structure was very low, with all the responses grouped around the bottom of the scale.

- (9) Ellos **te** **me** empujan
 They 2.SG.ACC 1.SG.NAD push
 ‘They push you (and I’m affected by it)’

Furthermore, for this structure type, participants rated all the items containing an ungrammatical cluster (*os nos* and *os me*) with a 1, which is the lowest value of the rating scale.

With respect to the DAT-NAD structure, which contains two datives, we can see in Table 4.4 and Figure 4.2 that all conditions were rejected across the board. In the case of DAT-NAD we find even lower overall ratings for all clusters, as compared to the ACC-NAD structure. An example of this structure type is reproduced in (10).

- (10) Ellos **te** **me** pintan la cara
They 2.SG.DAT 1.SG.NAD paint the face
'They paint your face (and I'm affected by it)'

The REFL-NAD structure type, reproduced in (11), displays a rather different pattern when compared to the first two structures.

- (11) Tú **te** **me** enfermas
You 2.SG.REFL 1.SG.NAD get.sick
'You get sick (and I'm affected by it)'

In this case, the grammatical clusters in the REFL-NAD structure received much higher rates, whereas the ratings of the ungrammatical conditions remained extremely low.

Finally, the REFL-DAT structure type, reproduced in (12), also shows much higher acceptance in the case of the grammatical clusters, while the ungrammatical ratings remain very low.

- (12) Tú **te** **me** presentaste
You 2.SG.REFL 1.SG.DAT introduced
'You introduced yourself to me'

This pattern coincides with that of the REFL-NAD structure but, in this case, the overall acceptance of *te me* and *te nos* is even higher than in the case of REFL-NAD.

These results show differences in the treatment of the four structure types included in the experimental design. Whereas the ungrammatical clusters are rejected across the board, the acceptance of grammatical clusters is influenced by the type of structure. Specifically, ACC-NAD and DAT-NAD are treated differently from REFL-NAD and REFL-DAT on the one hand, and the grammatical clusters show significantly less rejection in the reflexive structures than in the non-reflexive ones. As such, the results of the ANOVA reveal a significant interaction between Structure and Cluster in these data ($F(9,207)=22.175, p<.001$).

In sum, with respect to structure type, and in addition to the singular-plural pattern predicted by the FMC and NPBE, these data indicate that structure type also has an effect on the acceptability patterns of clitic combinations.

As discussed in Chapter 2, authors such as Ormazabal and Romero (2007) and Bianchi (2006), suggest that non-argumental datives are not subject to person-case restrictions. However, contrary to this claim, the results presented in Table 4.4 and Figure 4.2 suggest that it is not the presence or absence of a non-argumental dative which determines the acceptability of the cluster but rather the presence of a reflexive pronoun. Crucially, ACC-NAD and DAT-NAD, which contain a non-argumental dative, both show a strong rejection of all clusters. In contrast, REFL-NAD, which also has a non-argumental dative, shows a completely different pattern and the results of this structure type align with those displayed by the REFL-DAT structure, even though one structure contains a non-argumental dative and the other one does not.

Given the clear-cut distinction in the treatment of clusters with and without reflexives, we now turn to analyze this factor in greater detail. As Reflexivity was

not considered a factor in the original experimental design, the following subsection presents the results of the GJ task with the four different structures collapsed into two larger groups, depending on whether the item contains a reflexive clitic or not.

Non-reflexive versus Reflexive conditions

When we group the two structure types with no reflexives and the two structure types with a reflexive, the differences become more apparent.

Table 4.5. Overall results for the NON-REFL and REFL conditions

Cluster with no reflexives			Clusters with a reflexive		
CLUSTER	MEAN	ST. DEV	CLUSTER	MEAN	ST. DEV
<i>te me</i>	1.56	1.066	<i>te me</i>	5.062	2.3605
<i>te nos</i>	1.46	.966	<i>te nos</i>	4.58	2.426
<i>os nos</i>	1.00	.000	<i>os nos</i>	1.65	1.037
<i>os me</i>	1.06	.306	<i>os me</i>	1.17	.545

Table 4.5, above, provides the mean and standard deviation values for both the non-reflexive and the reflexive types and Figure 4.3, below, shows the results according to the data reported on Table 4.5.

As discussed above, the grammatical clusters were treated very differently in the non-reflexive and reflexive conditions. In fact, the results of a 2x4 repeated measures ANOVA with Reflexivity and Cluster as the within-subjects factors reveal a main effect for Reflexivity ($F(1,23)=65.180, p<.001$) as well as a main effect for Cluster ($F(3,69)=41.545, p<.001$) and a significant interaction between Reflexivity and Cluster ($F(3,69)=43.328, p<.001$).

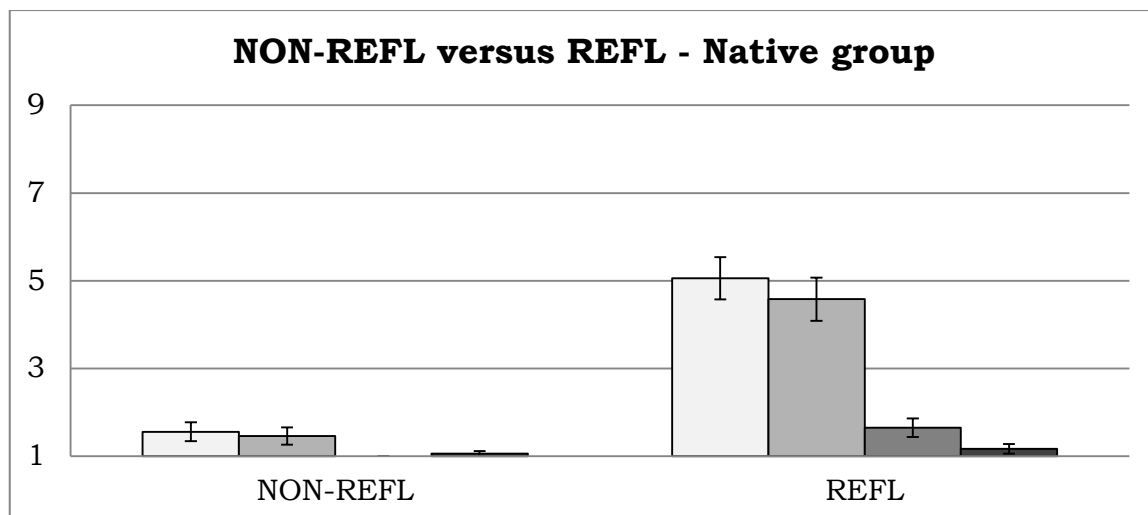

Figure 4.3. Average native group results for the NON-REFL and the REFL structures

As in the previous analysis, in the case of Cluster, pairwise comparisons using the Bonferroni correction reveal significant differences between the grammatical and the ungrammatical clusters. Specifically, we find significant differences between *te me* and *os nos* ($p < .001$), *te me* and *os me* ($p < .001$), *te nos* and *os nos* ($p < .001$) and *te nos* and *os me* ($p < .001$).

Whereas all four clusters were unanimously rejected for the non-reflexive conditions, the grammatical clusters were accepted significantly more in the reflexive conditions. The ungrammatical clusters were rejected in the non-reflexive conditions as much as in the reflexive ones and both conditions presented values around the lowest value. Only the differences between non-reflexive *os nos* and reflexive *os nos* were significant because this cluster was assigned the value 1 by all participants in all items from the non-reflexive conditions, whereas the ratings for the reflexive conditions presented a certain degree of variability.

In sum, collapsing the non-reflexive and the reflexive conditions provides a clear view of the pattern that emerges when we consider both the effects of the singular-plural asymmetry and the syntactic structure of the clitic cluster.

In view of these results, it becomes clear that the clusters that violate the NPBE (*os nos* and *os me*) are uniformly rejected by native participants and that, in this respect, the structure type does not have an influence in the way speakers treat ungrammatical clusters. However, the treatment of structures that comply with the NPBE (*te me* and *te nos*) varies across structure types. Specifically, grammatical clusters are more readily accepted in the case of structures that contain a reflexive than in structures without reflexives. Furthermore, the low grammatical rates in the non-reflexive structures are similar to those assigned to ungrammatical clusters.

This demonstrates that syntactic structure has an effect on the treatment of clitic clusters but, interestingly, this effect becomes evident not in the treatment of ungrammatical clusters, but in the treatment of grammatical ones. In addition, the determining factor for the higher rates of grammatical clusters seems to be the presence of a reflexive. Consequently, these results challenge the argument that 1st and 2nd person clusters are only possible with non-argumental datives, as defended by authors such as Ormazabal and Romero (2007) and Bianchi (2006).

Distribution of responses across clusters

We have seen in the previous subsections that, in the case of the reflexive conditions, the average responses for the grammatical clusters are grouped around 5, which corresponds to a neutral value in the scale. This may give the impression

that the speakers were uncertain as to how to treat these clusters and, as a consequence, they assigned neutral values to them. However, an analysis of the distribution of all the responses produced by the participants, shows that this is not the case. As discussed at the beginning of the results section, this average around the value 5 is an effect of collapsing data from speakers that show two different tendencies. On the one hand, some speakers tended to give low rates to all clusters and, on the other hand, other speakers tended to give high rates to the grammatical reflexive conditions. This divergence between “low raters” and “high raters” produced a cancelling effect, thus leaving the average for the group close to the neutral value 5.

Table 4.6. Distribution of responses across clusters

VALUE	<i>te me</i>	<i>te nos</i>	<i>te nos</i>	<i>os nos</i>	TOTAL
1	90	101	170	179	540
3	37	34	11	8	90
5	11	5	3	0	19
7	30	35	4	2	71
9	24	17	4	2	47

Table 4.10 above, shows the distribution of responses across cluster types and provides the number of responses for each value of the 5-point Likert scale presented to the participants. Figure 4.4 below, shows the distribution of responses according to the data reported on Table 4.6.

Figure 4.4 shows that 1 is the most prevalent rate in all clusters. However, the predominance of values 1 and 3 in the grammatical clusters is partially due to the fact that Table 4.6 and Figure 4.4 plot overall results, including responses from both the non-reflexive and the reflexive conditions. Nevertheless, we see a clear contrast between the grammatical and the ungrammatical clusters. Specifically, in

the case of grammatical clusters, we can see that ratings of 1 are not as prevalent as in the ungrammatical ones and the highest values of the scale are also present in the distribution.

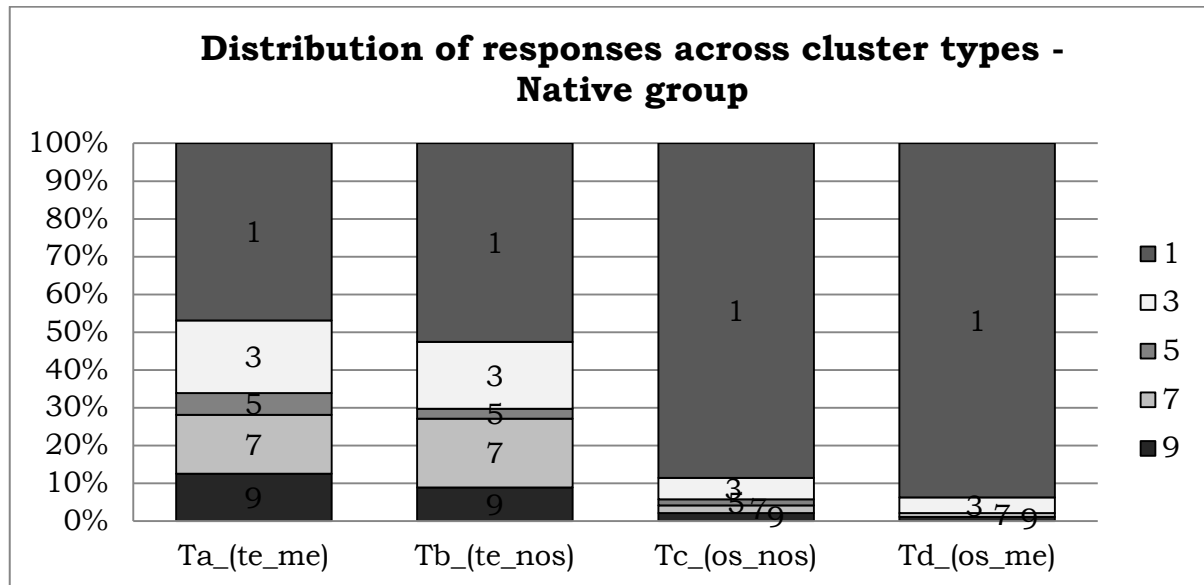

Figure 4.4. Distribution of responses from the native group across cluster types

In line with the discussion at the beginning of this section, the presence and weight of all 5 values of the scale for the grammatical clusters may look like a sign of uncertainty or random value assignment by the participants. However, a subject analysis shows a trend that may be indicative of two types of speaker: one type who rates all 1st and 2nd person combinations with the lowest rates regardless of number or structure type, and another type who is sensitive to both number and structure type and who, as such, assigns different values to the different clusters based on these two parameters. This division among high-rating and low-rating speakers is discussed in further detail in the following subsection.

High raters versus low raters

In the discussion of the overall results, at the beginning of this section, I argued that one of the reasons for the low overall ratings illustrated in Table 4.3 and Figure 4.1 is that it collapses different syntactic structures that are treated very differently by the speakers. This became evident when each structure type was analyzed separately. In addition, I pointed out that the fact that even in the reflexive grammatical clusters the values remain around the mid-point of the scale is not due to uncertainty by the speakers when judging these clusters, but to the cancelling effect of averaging the ratings from speakers who tended to give low rates across the board, henceforth low raters, and speakers who were sensitive to the singular-plural asymmetry and structure type, henceforth high raters. We can see the breakdown of responses by a sample low rater on Table 4.7 and that by a high rater on Table 4.8.

These two tables show that both participants give similar ratings to the ungrammatical conditions in all structure types and also to the grammatical conditions in the non-reflexive structures. In the case of the grammatical reflexive conditions, however, the two participants differ significantly. Thus, given the fact that all speakers uniformly rated the non-reflexive conditions with the lowest values of the scale, the difference between the high rather and the low raters becomes evident in the reflexive conditions.

If we set the boundary between the two types of speaker at the midpoint of the scale, i.e. at 5, on the reflexive conditions we obtain an approximate distribution of 13 high raters and 11 low raters.

Table 4.7. Sample low rater (participant 101)

STRUCTURE	<i>te me</i>	<i>te nos</i>	<i>te nos</i>	<i>os nos</i>
ACC-NAD	1	1	1	1
ACC-NAD	1	1	1	1
DAT-NAD	1	1	1	1
DAT-NAD	1	1	1	1
REFL-NAD	1	1	1	1
REFL-NAD	1	1	1	1
REFL-DAT	1	1	1	1
REFL-DAT	3	1	1	1
MEAN	1.25	1	1	1

Table 4.8. Sample high rater (participant 118)

STRUCTURE	<i>te me</i>	<i>te nos</i>	<i>te nos</i>	<i>os nos</i>
ACC-NAD	1	1	1	1
ACC-NAD	3	7	1	1
DAT-NAD	1	1	1	1
DAT-NAD	1	3	1	1
REFL-NAD	7	7	1	1
REFL-NAD	7	7	1	1
REFL-DAT	7	7	1	1
REFL-DAT	9	7	3	1
MEAN	4.5	5	1.25	1

Table 4.9, which shows the average ratings of all participants both overall and for the reflexive conditions, reveals a rather balanced distribution between high raters and low raters. The participants are arranged in ascending order on each section of the table and, as such, the ordering of participants according to their ratings for the reflexive conditions and their overall ratings do not have a one to one correspondence in all cases. Nevertheless, all the participants that were classified as “high” raters in the reflexive conditions are also the ones that provide higher overall ratings, so the same distribution of participants is maintained both in the reflexive conditions and overall.

Table 4.9. Average ratings for the REFL conditions per participant (left) and average overall ratings per participant (right) in ascending order

Reflexive conditions			Overall results		
PART.	REFL GRAM	REFL UNGRAM	PART.	TOTAL GRAM	TOTAL UNGRAM
107	1	1	107	1	1
101	1.25	1	101	1.125	1
110	1.25	1	110	1.125	1
111	1.25	1	111	1.125	1
103	2.5	1.25	103	2	1.125
114	3	1	114	2	1
108	3.75	1	122	2.375	1
122	3.75	1	106	2.5	1.625
106	4	2.25	115	2.5	1
115	4	1	102	2.625	1
102	4.25	1	108	2.75	1
117	5	1	113	3.125	1
113	5.25	1	120	3.25	1.125
120	5.25	1.25	109	3.375	1
109	5.5	1	104	3.875	1.875
105	6.25	1.5	112	4.125	1
104	6.5	2.75	121	4.125	2.125
121	6.5	3.25	124	4.25	1.125
116	7	1	105	4.5	1.25
112	7.25	1	118	4.75	1.125
118	7.25	1.25	116	4.875	1
124	7.25	1.25	117	4.875	1
123	8	2.5	123	5	2.125
119	8.75	2.5	119	6.625	1.75

An exploratory analysis of the participants does not reveal a clear demographic identifying feature that may account for the difference in their response patterns. There were seven females and four males in the low rating group and the nine females and four males in the high rating one. The mean age for the low rating group was 39.27 for the low rating group and 32.54 for the high rating one. The majority of speakers from both groups came from the same region (Castille and Leon) and had a university degree. All participants had some

knowledge of other languages, but they were all native speakers and their dominant language was Spanish. The distribution of speakers who came from a different region and/or had a different level of education was similar in both groups.

The existence of high raters and low raters is a clear indicator of variability within the language. This is consistent with the apparent variability in the acceptance of 1st/2nd person clusters in Italian observed by several authors (Bonet 1991; Nicol 2005; Bianchi 2006), as well as with the fact that some authors argue for the acceptability of 1st and 2nd person clusters in Spanish (e.g. Bonet 1991), whereas other authors argue against it (e.g. Ormazábal and Romero 2007).

4.1.7 Conclusions from the grammaticality judgment task

Based on the results of Nevins and Săvescu's (2010) study of clitic clusters in Romanian, the participants of this scaled grammaticality judgment task were expected to accept clitic clusters in which the non-dative is singular and reject clusters in which the non-dative is plural, in accordance with the predictions made by the FMC and the NPBE. The results of the task show that, indeed, conditions in which the non-dative was plural were very strongly rejected by all participants. In turn, conditions with a singular non-dative were more readily accepted. Consequently, the findings of this experiment align with those reported by Nevins and Săvescu (2010) and provide further support for the validity of the FMC and the NPBE as predictors of the acceptability of 1st and 2nd person clusters by native speakers.

In addition, the results of the task also provide some insight into the effects of the syntactic structure on the perception of clitic clusters in Spanish. In fact, the data, which included clusters with argumental and non-argumental datives, demonstrate that both structure type and the presence of a plural non-dative in the cluster have an effect on the native speakers' perception of clitic clusters. We have seen that having a plural non-dative clitic in a cluster is a determining factor for the acceptance or rejection of such a cluster. We have seen as well that structure type also has an effect on the acceptability patterns of clitic combinations. It is discussed in Chapters 1 and 2 that authors such as Albizu (1997), Ormazábal and Romero (2007) and Bianchi (2006) suggest that non-argumental datives are not subject to person-case restrictions. However, it is not the presence or absence of a non-argumental dative which determines the acceptability of a cluster. In fact, we have seen in the results of the grammaticality judgment task that structures with argumental and non-argumental datives display similar patterns. In other words, ACC-NAD behaved similarly to DAT-NAD and REFL-NAD behaved similarly to REFL-DAT. In contrast, the presence or absence of a reflexive proved a much better indicator of the acceptability of the cluster, since clusters containing a reflexive were accepted at much higher rates than clusters without reflexives regardless of the case assigned to the other clitic in the cluster.

These differences among structure types appeal to syntax as a key element to help account for clitic cluster restrictions in Spanish. Furthermore, these results, which highlight a manifest interaction between feature markedness and structure type, support the idea proposed in Chapter 2 that both morphology and syntax play a role in the acceptability of clitic clusters.

In addition, these results raise questions about the status of reflexives, and about what makes them more acceptable than non-reflexives in a cluster.

Binding Theory (Chomsky, 1981; see also Chomsky 1995) proposes that reflexives—or anaphors—are governed by Condition A and pronouns are governed by Condition B. The three conditions of Binding Theory, as stated by Chomsky (1991:188), are reproduced in (13).

(13) Binding Theory

(A) An anaphor is bound in its governing category

(B) A pronominal is free in its governing category

(C) An R-expression is free

This means that, unlike pronouns, reflexives require a local antecedent (Radford, 1997) or, in other words, they must be coreferential with a preceding c-commanding expression (Adger, 2003).

The results of the grammaticality judgment task suggest that coreferentiality between the subject and the reflexive, that is, the fact that both arguments share the same features, is directly linked to higher acceptance rates of clusters. This relates clitic phenomena to the notions of c-command and locality. However, available theoretical accounts, even those that rely on the notions of c-command and locality, such as Albizu's (1997), do not integrate the effects of reflexives in clitic cluster restrictions in their proposals and they often leave aside further considerations on non-argumental clitics. The findings of this experiment,

however, suggest that these two aspects must be integrated in a comprehensive account of clitic restrictions in Spanish.⁹²

4.2. ON-LINE SELF-PACED READING TASK

As mentioned at the beginning of this chapter, one aspect that has not been explored in studies regarding clitic clusters in Romance is whether there is a connection between the acceptability patterns of clitic clusters and language processing or, more specifically, whether the acceptance or rejection of a given cluster may be related to language processing limitations.

At the beginning of the chapter I proposed three general research questions, reproduced below:

I. Whether the perception of clitic clusters by native speakers of Spanish patterns with the restrictions stipulated by the FMC and the NPBE or, in other words, whether the FMC and the NPBE successfully predict the acceptability patterns displayed by native speakers of Spanish.

II. Whether experimental data will provide us with valuable information that may help us determine the effects of the syntactic structure on clitic restrictions and provide us with a better understanding of how syntax and morphology interact in these contexts.

III. Whether the restrictions expressed in clitic combination restrictions, specifically the FMC and the NBPE, can be related to processing constraints.

The data from both experiments provide resources to attempt an answer to questions I and II and, in addition, experiment 2 specifically addresses question III.

⁹² The proposal of such an account is beyond the scope of this dissertation.

As discussed in Chapter 1, a core aspect of clitic cluster restrictions lies in the fact that ungrammatical sentences due to FMC and NPBE violations are actually well-formed syntactic structures from a derivational point of view.

The sentence in (14b) is ungrammatical because there is an agreement mismatch between the subject *vosotros* and the reflexive clitic *te*. As we have seen in section 4.1.8, Principle A states that these two pronouns must be coreferential. However, in (14b), the features of the reflexive and those of its antecedent do not match, thus triggering the ungrammaticality. This mismatch does not occur in (14a) and, therefore, the sentence is grammatical because it also complies with the NPBE.

- (14) a) Tú **te** **nos** pusiste enfermo.
 You.SG 2.SG.REFL 1.PL.DAT put sick
 'You (sg) got sick (on us)'
- b) *Vosotros **te** **nos** pusisteis enfermos.
 You.PL 2.SG.REFL 1.PL.DAT put sick
 'You (pl) got sick (on us)'

In the case of (15), both sentences imply a violation of the NPBE and, consequently, they are ungrammatical. However, the basic grammatical requirements, such as agreement between the reflexive clitic and its referent, are met in both (15a) and (15b).

- (15) a) *Vosotros **os** **me** pusisteis enfermos
 You.PL 2.PL.REFL 1.PL.DAT put sick
 'You (pl) got sick (on me)'

- b) *Vosotros **os** **nos** pusisteis enfermos.
You.PL 2.PL.REFL 1.PL.DAT put sick
'You (pl) got sick (on us)'

Even though (14b) contains a grammatical error and (15b) is grammatically well-formed, we find that both sentences are ungrammatical, which poses interesting questions with respect to the nature and processing of the two types of ungrammaticality. Specifically, we may ask whether the two different types of ungrammaticality are processed differently or, in other words, whether different types of ungrammaticality may trigger differences in processing.

First, we need to find out whether there is a processing effect triggered by the NPBE ungrammaticality and, second, we need to see if the effect is also present in the syntactic ungrammaticality and whether the two effects are comparable.

It is well established that in sentence processing and production the parser does not wait until it has a complete and fully formed sentence to start processing it. Rather, processing starts immediately upon encountering speech or text (see Pickering and van Gompel, 2006 and further references therein). Furthermore, a number of studies suggest that the speaker is even able to “anticipate properties of upcoming words in the sentence” (Pickering and van Gompel, 2006:455).

This view assumes that language operates incrementally, in the sense that, rather than waiting until it reaches the end of the sentence, the parser takes an active role and computes the sentence structure as new words are encountered. In addition, the incremental model assumes that the parser takes advantage of the sequential nature of language production, combining syntactic flexibility and

lexical accessibility to determine the form of a sentence (see Bock, 1982; Kempen, 1987; Kempen and Hoenkamp, 1987; Levelt, 1989; DeSmedt, 1990; and Ferreira, 1996; among others).⁹³

Assuming the notion of incrementality in sentence processing, the two types of ungrammaticality presented in (14b) and (15b) may arguably display noticeable processing differences. On the one hand, in the case of the agreement mismatch, the parser may still be able to “oversee” the error, continue building a valid syntactic structure and, therefore, successfully process the sentence despite the syntactic violation. In the case of the NPBE violation, on the other hand, encountering a 2nd person plural clitic in first position implies that the parser will automatically eliminate the possibility of interpreting that the clitic is part of a 1st /2nd person cluster. If the plural clitic is a dative, then it can only be a cluster if the next clitic is 3rd person (let us recall that, in Spanish, the word ordering preference in 1st and 2nd clitic clusters follows the ACC-DAT pattern). If the plural is non-dative, then it cannot be part of a 1st /2nd person cluster, since it would violate the NPBE. Thus, when it reaches the second clitic, the parser is blocked at the impossibility of accommodating the input to one of the two only possible structures: 1) 2nd person plural clitic followed by a 3rd person clitic or 2) no cluster.

In order to analyze the mechanisms used by the parser when processing sentences with a clitic cluster—and their violations—, I designed an on-line self-paced reading task which contains three types of conditions: *grammatical* (a well-formed syntactic structure and compliant with the NPBE), *NPBE ungrammatical* (a well-formed syntactic structure but non-compliant with the NPBE) and

⁹³ For further discussion of incrementality in language production, the reader is referred to Ferreira and Engelhardt (2006).

syntactically ungrammatical (an ill-formed syntactic structure with a subject-reflexive agreement mismatch).

The on-line self-paced reading technique has proven useful in the analysis of parsing strategies with respect to anaphor binding constraints (Badecker and Straub, 2002; Kennison, 2003; Alba de la Fuente and Dukova-Zheleva, 2007) and structural dependencies, such as clitic left-dislocation constructions and topicalization in Spanish and Galician (Pablos, 2006).

4.2.1 Research Questions

This experiment aims to answer two main research questions. First, with respect to language processing, will the NPBE affect the processing of sentences with 1st and 2nd person clitic combinations? More specifically, will combinations that violate the NPBE show longer reading times than combinations which comply with it? Second, will different types of ungrammaticality (i.e. agreement mismatch versus NPBE violations) yield different reading times?

4.2.2 Hypotheses

The results of experiment 1 complied with the predictions made by the FMC and the NPBE and also patterned with the results of Nevins and Săvescu's (2010) study with native speakers of Romanian. In view of this, we expect the on-line task to produce similar results and show differences between the different clitic combinations. Even though both experiment 1 in this dissertation and Nevins and Săvescu's (2010) study were grammaticality judgment tasks, we expect the

significant rejection of clitic combinations with plural to be apparent in the self-paced reading task as well.

On a general level, the grammatical conditions, i.e. those that comply with both the syntactic requirements and the NPBE, are expected to show no effect and have the fastest reading times. In contrast, the ungrammatical conditions are expected to show an effect and have longer reading times. In addition, reading time differences are also expected with respect to the two types of ungrammaticality.

The previous section considered potential processing differences between the syntactic ungrammaticality and the NPBE violation. Specifically, in the case of the NPBE violation, the unexpected second clitic may block the parser, since it would make it impossible to continue building or reanalyze the structure of the sentence. In the case of the syntactic violation, however, if the parser identifies that there is an agreement error, it may still be able to build the sentence structure, since no other element contradicts the predicted syntactic structure. Based on this, we may expect to find longer reading times for the NPBE violations than for the syntactic violations.

4.2.3 Experimental design and materials

There were two types of items in the experiment: experimental items and fillers, with a total of 24 experimental items and 48 fillers, making a total of 72 sentences in the experiment. Table 4.10 presents a breakdown of the items included in the experiment.

Table 4.10. On-line self-paced reading task item distribution

ITEM	REFL-NAD	REFL-DAT	OTHER	TOTAL
Experimental	12	12	N/A	24
Fillers	N/A	N/A	48	48
TOTAL	12	12	48	72

As in the grammaticality judgment task, all the experimental items contained a 1st and 2nd person cluster that was manipulated with respect to number. In addition, two types of structure were included in order to determine whether structure type also has an effect on processing. The two structures included in the test are combinations of Reflexive and Ethical Dative (REFL-NAD), as in (4c), reproduced here as (15a) and combinations of Reflexive and Dative (REFL-DAT), as in (4d), reproduced here as (15b).

- (15) a) Tú **te** **me** enfermas
 You 2.SG.REFL 1.SG.NAD get.sick
 ‘You get sick (and I’m affected by it)’
- b) Tú **te** **me** presentaste
 You 2.SG.REFL 1.SG.DAT introduced
 ‘You introduced yourself to me’

In view of the results of the GJ task, the two non-reflexive conditions were eliminated in the on-line task for their potential confounding effect. These two conditions were significantly more rejected than their counterparts in reflexive sentences, even for the grammatical clusters. This implies that non-reflexive structures could potentially show an effect on all conditions, both grammatical and ungrammatical, which could confound any actual NPBE-driven effects. Consequently, only the two reflexive structure types were retained for the on-line

task, since differences between the grammatical and the ungrammatical conditions are expected to be more visible in clusters with reflexives.

These two structures were included to determine whether the type of structure (i.e. the case assigned to the clitics in the cluster) had differentiated processing effects that would parallel the perception differences evidenced in the scaled grammaticality judgment task.

There were 12 items for each of the two structures, which made the total of 24 experimental items reported in Table 4.14, and the 48 fillers included sentences with clusters that contained 3rd person clitics, as well as sentences with clitics and other pronouns whose structures were unrelated to the study (such as quirky subjects and regular ditransitives).⁹⁴

Each experimental item had five conditions: Condition A contained two singular clitics (*te me*), condition B contained a singular non-dative and a plural dative (*te nos*), condition C contained two plural clitics (*os nos*), condition D contained a plural non-dative and a plural dative (*os me*) and condition E contained an agreement mismatch between the reflexive clitic and its antecedent, which always corresponded to the subject of the main clause.⁹⁵

Here follows a sample experimental set with the five conditions:

- (16) A) *Contigo siempre suceden cosas inesperadas como pasó aquella vez, cuando eras más pequeño, que **te me** perdiste en el supermercado.*

‘There are always unexpected things with you (sg), like that time, when you were little, that you got lost (on me) in the supermarket’

⁹⁴ The controls and fillers were the same as in the GJ task. See (6) and (7), above, for sample items of each type.

⁹⁵ In all cases, both the cluster and the antecedent were in the main clause.

B) *Contigo siempre suceden cosas inesperadas como pasó aquella vez, cuando eras más pequeño, que **te nos** perdiste en el supermercado.*

‘There are always unexpected things with you (sg), like that time, when you were little, that you got lost (on us) in the supermarket’

C) *Con vosotros siempre suceden cosas inesperadas como pasó aquella vez, cuando erais más pequeños, que **os nos** perdisteis en el supermercado.*

‘There are always unexpected things with you (pl), like that time, when you were little, that you got lost (on us) in the supermarket’

D) *Con vosotros siempre suceden cosas inesperadas como pasó aquella vez, cuando erais más pequeños, que **os me** perdisteis en el supermercado.*

‘There are always unexpected things with you (pl), like that time, when you were little, that you got lost (on me) in the supermarket’

E) *Con vosotros siempre suceden cosas inesperadas como pasó aquella vez, cuando erais más pequeños, que **te nos** perdisteis en el supermercado.*

‘There are always unexpected things with you (pl), like that time, when you were little, that you (sg) got lost (on us) in the supermarket’

As we can see in (16), each condition was minimally altered and only in order to maintain grammatical consistency, as reflected in the example with *contigo* ‘with you (sg)’ in conditions A, B and *con vosotros* ‘with you (pl)’ in conditions C, D, E. In addition, in order to minimize any potential effect from these

minimal changes, the word immediately preceding the first clitic, usually an adverb, was the same in all five conditions.

Since there were five conditions per experimental item, all the materials were automatically distributed into five different lists, so that each participant saw all items (experimental and fillers) and only one condition for each item. Thus, each participant saw a total number of 72 sentences with their corresponding questions. The experiment also contained 3 practice trials at the beginning in order to help the participants get used to the characteristics of the experiment.

Finally, considering their grammaticality status and the different nature of the ungrammaticalities, it is possible to group the five experimental conditions into three larger conditions. First, A and B can be grouped into a *grammatical* condition since they are both well-formed syntactic structures which also comply with the NPBE; second, C and D may be grouped into an *ungrammatical* condition in terms of the NPBE, or **NPBE* condition, since they are also well-formed syntactic structures but they both violate the NPBE; and third, E remains as the “syntactically ungrammatical” condition, or **syntactic* condition, since it contains an ill-formed syntactic structure with a subject-reflexive agreement mismatch. In fact, this organization of the results will allow us to address research question 2 directly (*Will different types of ungrammaticality (i.e. agreement mismatch versus NPBE violations) yield different reading times?*).

The discussion of the results in section 4.2.7 includes an analysis considering both the results of the five conditions separately and the grouped condition results.

4.2.4 Procedure

A word-by-word self-paced reading technique using a moving window display was used for this experiment. The materials were presented to the participants using the Linger software (Doug Rohde, MIT) on a 14" PC ASUS laptop computer. The materials were automatically randomized by Linger and presented in three blocks with time for the participant to rest between blocks.

Participants were asked to read carefully a number of sentences on a computer screen. At the beginning of each trial, a string of dashes appeared, each dash corresponding to a word of the sentence. Words appeared one by one and they followed the linear order of the sentence. In order for each new word to appear, the participant had to press the space bar. Each time the space bar was pressed, the word on screen disappeared and the next word appeared. At the end of each sentence, a *yes/no* comprehension question appeared on the screen and the participant was instructed to provide an answer by pressing either the *yes* or the *no* button. The purpose of these questions was to encourage the participant to read attentively and to verify that they had read and understood the sentences presented to them.

Every word in the sentence formed a region, and reading times (measured in milliseconds) were registered for every region.⁹⁶ Accuracy was controlled through the *yes/no* questions presented at the end of each trial. The complete experiment took, on average, 30 to 35 minutes to complete.

⁹⁶ Occasionally, two words that did not belong to the critical regions and that were part of the same syntactic unit (e.g. a DP) were collapsed to ensure that the critical regions were in the same position in every item. In all cases, the manipulation was the same in all conditions, which only differed in the presence or absence of plural clitics in the cluster and in the corresponding pronouns and verbal inflections.

4.2.5 Participants

A group of 23 native speakers of Peninsular Spanish, with normal or corrected to normal vision, participated in the experiment. All participants were adult speakers residing in Spain at the time of the experiment. In the language background questionnaire, all participants reported having some knowledge of other languages, mainly English (23) and French (14). Other languages that the participants spoke included: German (8), Italian (6) and Japanese (1). All the participants confirmed that their dominant language was Spanish, which was also the language they used most regularly and the one with which they were most comfortable at the time of testing. The mean age for the group was 27.2 years, with ages ranging from 21 to 42, and there were 16 female and 7 male participants. None of the participants of this experiment participated in the scaled grammaticality judgment task.

4.2.6 Results and discussion

Only data from participants who scored 80% or above accuracy on the comprehension questions were retained for further analysis. All participants had 80% or above correct responses for the experimental items, so no data were discarded at this point. In addition, all reading times (RTs) below 100ms and over 3000ms were also excluded. This resulted in a loss of less than 1% of the total data.

When working with experiments that measure reading times, it must be taken into consideration that the words in the experiment have different lengths and, accordingly, they are likely to display different reading times. This means that

it is not possible to make direct comparisons with raw reading times. Furthermore, reading times also vary across participants due to the differences in reading speed that occur naturally in any population. Thus, mean residual RTs were obtained in order to correct for word length, as well as for individual differences between participants' RTs.⁹⁷ First, a regression analysis was performed to determine the best fit for each word length. Then, the predicted value obtained through the regression analysis was subtracted from the raw RT. The obtained value is the mean residual RT, which indicates how distant the actual value was from the predicted best fit value for that word length. All values above three standard deviations from the participant's mean residual RT were excluded from the analysis, which affected approximately 1% of the data. Further analyses of the data, including Analysis of Variance (ANOVA), are reported in the following subsections.

Overall results

Previous studies that also deal with pronouns and use self-paced reading techniques (Badecker and Straub 2002; Kennison 2003) show that effects causing variation in reading times typically appear, not on the pronoun, but on the first words immediately after the pronoun. Taking this into consideration, the critical regions for this experiment are the ones corresponding to the two clitics of the cluster, which are regions 14 and 15, respectively, as well as the words that immediately follow the cluster, which correspond to regions 16 and 17. Based on previous studies, effects are expected to show at these regions. Later regions corresponded to the last words of the sentence, so they were not analyzed in order

⁹⁷ This includes naturally occurring reading speed differences as well as potential age effects.

to avoid end-of-sentence wrap-up effects that may confound an actual cluster or structure effect.

As indicated above, two analyses were performed, namely an analysis which groups the data into Grammatical, *NPBE and *Syntactic conditions, depending on their grammaticality status (3-condition analysis) and an analysis that considered each cluster as one condition (5-condition analysis). I first report the 3-condition analysis and then compare its results with the 5-condition analysis.

3-condition analysis

Figure 4.5 presents the overall results of the experiment with the data grouped into three conditions.

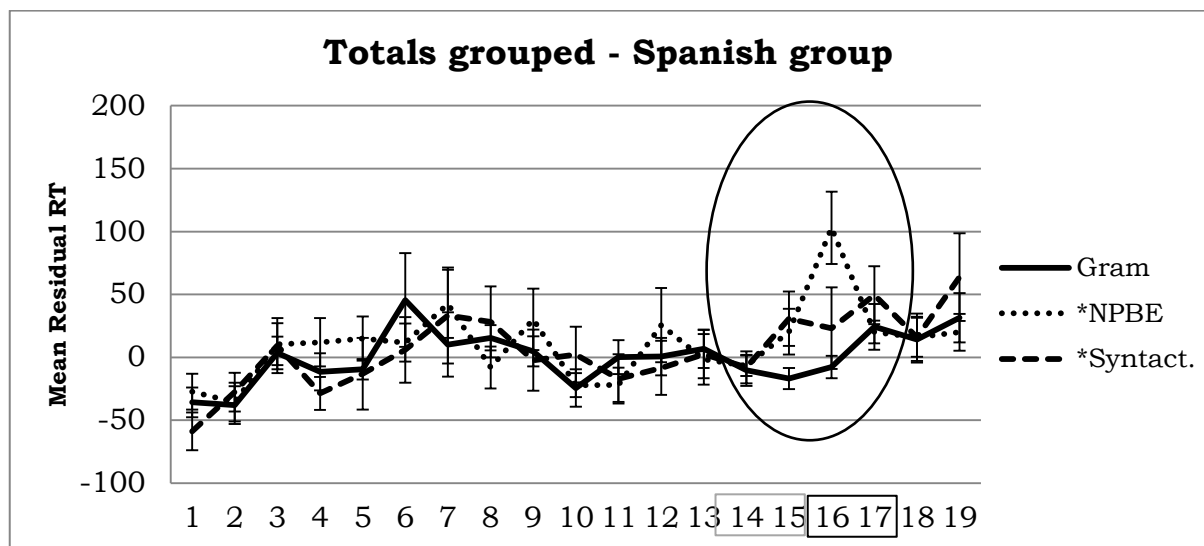

Figure 4.5. Native group overall results – grouped

As we can see, the overall results show a marked increase in the RTs of the *NPBE condition at region 16 as well as a moderate increase in the RTs of the *Syntactic condition between regions 15 and 17. In line with previous findings, the

effects of the clitic cluster are not apparent on the cluster itself (regions 14 and 15), but immediately after.

Figure 4.6, below, shows the results of the two different structure types, REFL-NAD and REFL-DAT, grouped into three conditions.

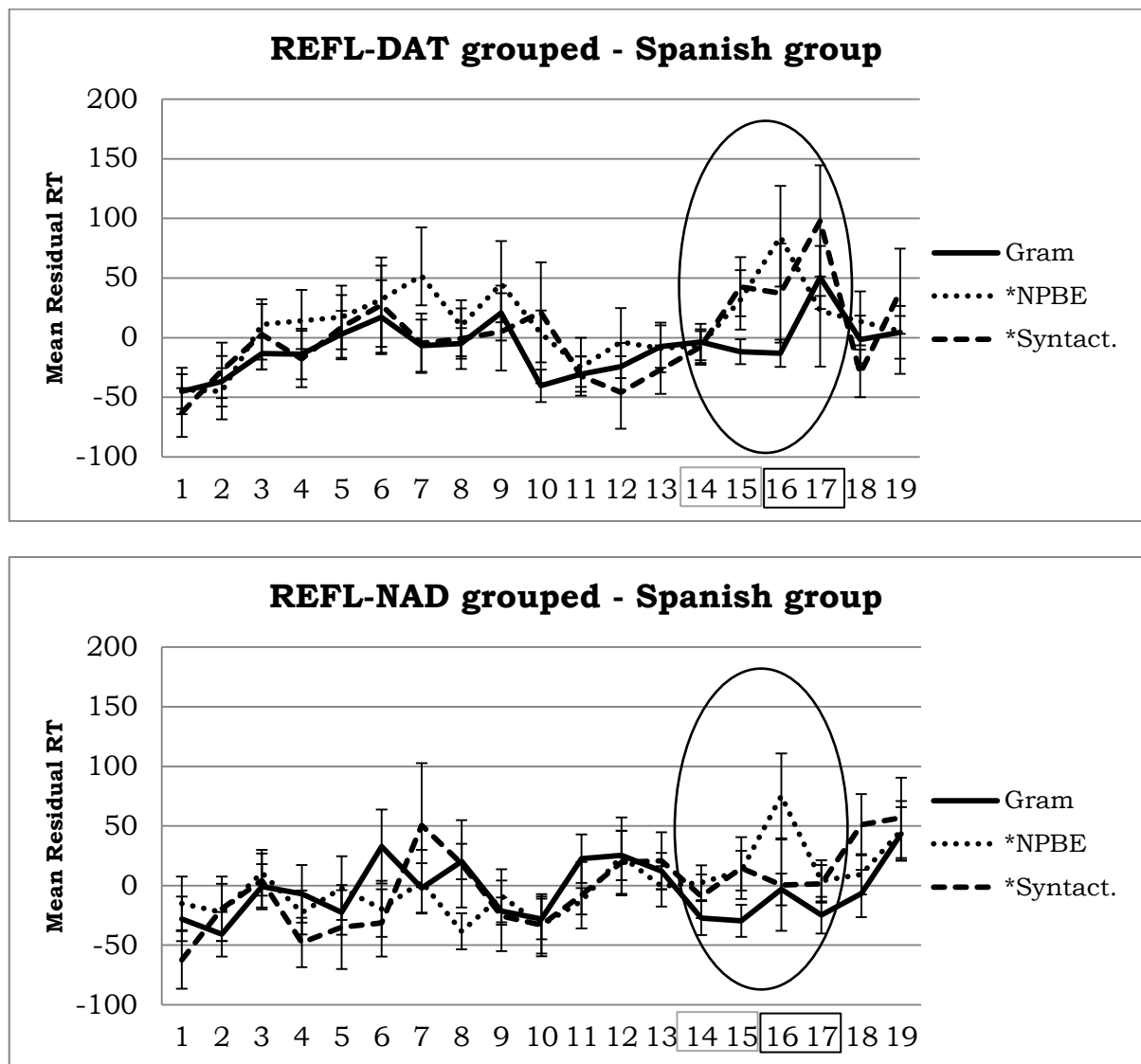

Figure 4.6. REFL-DAT and REFL-NAD grouped (3 conditions)

As shown in Figure 4.6, the two structures display a similar pattern with respect to the Grammatical and the *NPBE clusters. Specifically, there is no

increase in the RTs of the Grammatical cluster at the critical regions, whereas the opposite is true for the *NPBE condition. In both cases there is a marked increase in the RTs of the *NPBE clusters at region 16. In turn, the two structures differ in the treatment of the *Syntactic cluster. Specifically, whereas there is no effect in the case of the REFL-NAD structure for this condition, there is an increase in the RTs of the *Syntactic condition for the REFL-DAT structure that starts at region 15 and peaks at region 17.

In order to verify whether these differences were significant, a 2x3 repeated measures ANOVA for each critical region with Structure (REFL-DAT, REFL-NAD) and Cluster (Grammatical, *NPBE, *Syntactic) as the within-subject factors was performed on these data.

The results of the ANOVA reveal a main effect for Cluster at region 16 ($F(2,44) = 4.625$ $p = .015$) and a main effect for Structure at region 17 ($F(1,22) = 9.120$ $p = .006$).⁹⁸ With respect to Cluster, pairwise comparisons using the Bonferroni correction reveal significant differences between the Grammatical and the *NPBE conditions ($p = .003$).

As the results of the ANOVA indicate, the two structure types show similar patterns, but they also present some differences, which become significant at region 17. Besides an increase in the RTs of the Grammatical cluster at this region, the two differences between the two structures are particularly visible with respect to the behaviour of the *Syntactic condition in region 17. This corresponds to a lingering effect that seems to be present on the REFL-DAT data which, as discussed above, appears on the syntactic violation condition in the REFL-DAT structure, but not in the REFL-NAD one. The differences between clusters are not

⁹⁸ In this section, only statistically significant results are reported.

significant in this region because their respective RTs remain similar within each structure. In contrast, the differences with respect to Cluster are significant at region 16. Specifically, the statistical analysis reveals a significant difference between the Grammatical condition, with the shortest RTs, and the *NPBE condition, with the longest RTs.

5-condition analysis

Figure 4.7 presents the overall results of the experiment with all clusters presented separately.

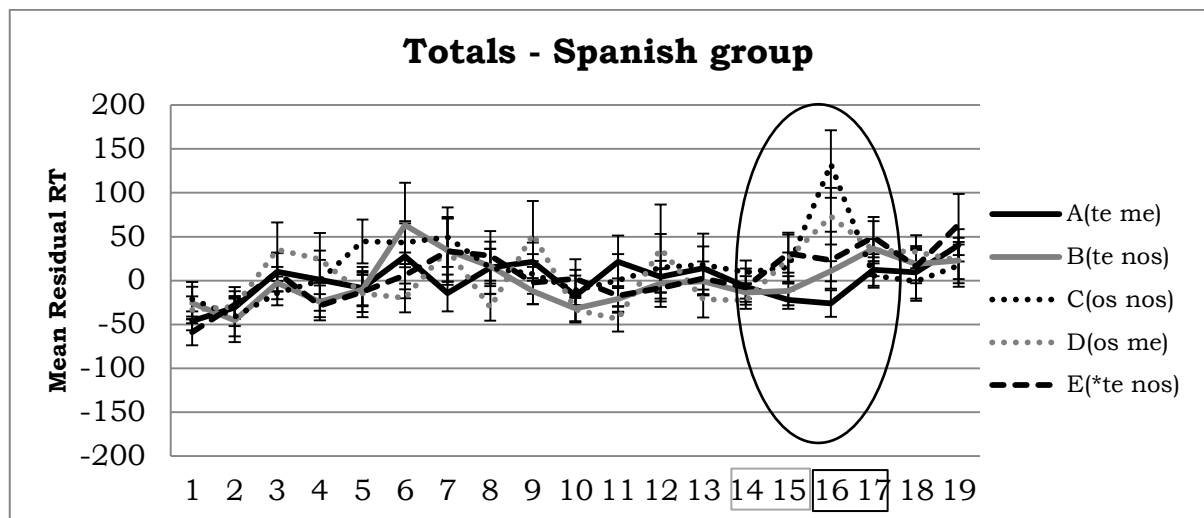

Figure 4.7. Native group overall results – by condition

As in the case of the 3-condition analysis, we observe that, in region 16, there is a spike in the RTs of the two *NPBE conditions, C (*os nos*) and D (*os me*). In turn, the shortest reading times correspond to the two grammatical conditions. Condition E (**te nos*), which corresponds to the syntactic violation, has longer reading times than the grammatical conditions, but not as long as the *NPBE ones. It is interesting to note that the longest RTs in this region correspond to C (*os nos*),

which contains two plural clitics (the highest accumulation of marked features), and the shortest RTs correspond to A (*te me*), which contains two singular clitics (the lowest accumulation of marked features).

Figure 4.8, below, shows the results of the two different structure types, REFL-NAD and REFL-DAT, with all clusters presented separately.

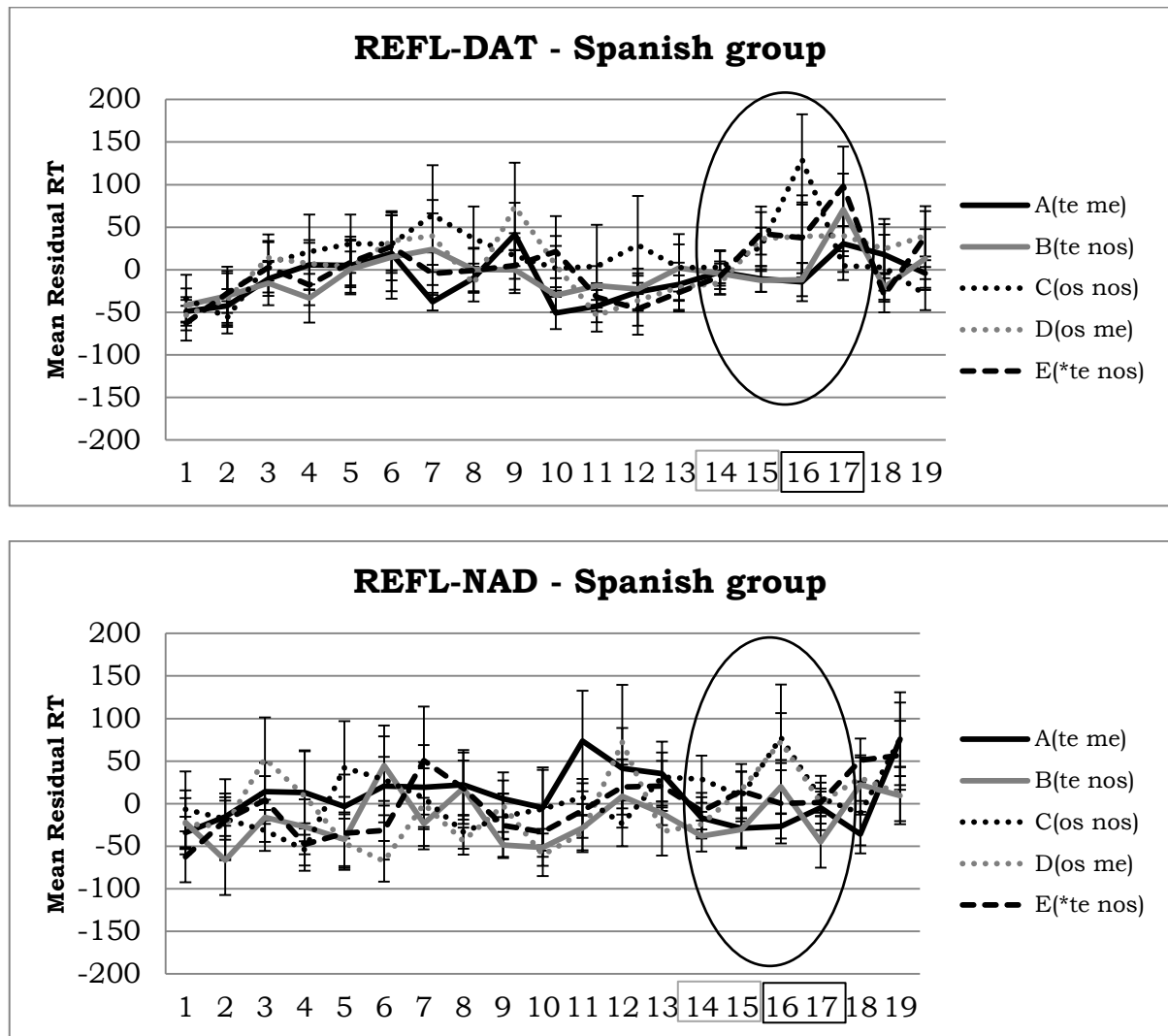

Figure 4.8. REFL-DAT and REFL-NAD (5 conditions)

As we can see in Figure 4.8, the two Ungramamtical conditions peak at region 16 in the case of the REFL-NAD structure. In the REFL-DAT structure,

condition C (*os nos*) peaks at region 16 and region E (**te nos*) peaks at region 17. We also find an increase in the RTs of the grammatical cluster B (*te nos*) at region 17.

In order to verify whether these differences are significant, a 2x5 repeated measures ANOVA for each region with structure type (REFL-DAT, REFL-NAD) and cluster type (“te me”, “te nos”, “os nos”, “os me” and “*te nos”) as the within-subject factors was performed on these data. The results of the ANOVA reveal a main effect for Cluster at region 16 ($F(4,88)=4.706$, $p=.002$) and a main effect for Structure at region 17 ($F(1,22)=10.990$, $p=.003$). With respect to cluster type, pairwise comparisons using the Bonferroni correction reveal significant differences between “te me” and “os nos” ($p=.013$) and near significant differences between “te nos” and “os nos” ($p=.058$).

As we can see, the two analyses (3-condition and 5-condition) reveal the same results, namely an effect for Cluster at region 16, where the Grammatical and the *NPBE conditions show statistically significant differences, and an effect for Structure at region 17, which is caused by longer RTs overall and a peak in the RTs of the *Syntactic condition in the REFL-DAT structure.

Overall, we can observe a strong effect guided by the NPBE. Thus, the conditions that violate the NPBE have the longest reading times. In addition, the syntactic ungrammaticality also seems to affect processing, but to a lesser extent than the NPBE violation. Finally, the grammatical conditions did not show an increase in RTs at the critical regions.

The *Syntactic condition peak found at region 17 of the REFL-DAT is unexpected and it contrasts with the results from the REFL-NAD structure. As in

previous cases, the *NPBE conditions show longer reading times in general. In the REFL-DAT structure, however, the syntactic violation seems to show a delayed peak compared to the NPBE violations. Furthermore, the increase in RTs is more pronounced for the syntactic ungrammaticality than for the NPBE violation and it spreads out through regions 15, 16 and 17. In this case, and in contrast with the REFL-NAD structure, the syntactic violation seems to linger on, whereas the NPBE violation of *os nos* causes an immediate effect right after the cluster. This delayed effect could be seen as an indicator of attempt at reanalysis or syntactic repair (i.e. trying to “save the sentence”) that is present for the *syntactic condition, but not for the NPBE violation, particularly in the case of condition C (*os nos*).

4.2.7 Conclusions from the on-line task

As expected, based on the results of experiment 1, NPBE ungrammaticalities produced significantly longer reading times than their grammatical counterparts, thus confirming that the parser is sensitive to clitic restrictions and that they affect processing.

In addition, the experiment considered two types of ungrammaticality: NPBE violations and syntactic errors by means of a subject-reflexive agreement mismatch. Based on general notions of incrementality in sentence processing, longer reading times were expected for the NPBE ungrammaticalities given the fact that an NPBE violation may block the parser’s ability to accommodate the input to a felicitous structure. As expected, reading times were, in general, longer for the *NPBE than for the *syntactic conditions, reaching significance in the overall grouped results.

The experimental design also included two syntactic structures, namely REFL-NAD and REFL-DAT. When the two structures were considered separately, the only significant differences in each case were those between the grammatical and the *NPBE conditions. In addition, the REFL-DAT structure showed a delayed effect for the *syntactic condition, but statistical analysis did not show robust significant differences. This effect was not visible in the REFL-NAD condition or in the overall results but, nevertheless, its presence suggests further processing differences between the *NPBE and the *syntactic conditions. With the exception of the delayed effect found in the *syntactic condition, the behaviour of the different clitic clusters did not differ significantly between the two structure types.

In general, the predictions were confirmed by the data, which show different reading times for all three types of condition (grammatical, *NPBE and syntactic violation). In all cases, the longest reading times corresponded to *NPBE conditions, followed by the syntactic violation. The grammatical conditions tended to have the fastest reading times. Thus, these results show that there is a difference in processing between the grammatical and *NPBE conditions, as well as between syntactic violations and NPBE violations. These differences are most apparent when the three types of condition and the two types of structure are collapsed.

4.3. GENERAL CONCLUSIONS FROM THE NATIVE DATA

Experiment 1 consisted of a scaled grammaticality judgment task (GJ). The FMC and the NPBE are supported by the GJ data, since there are significant differences in the acceptance rates of clusters with a plural non-dative and clusters without them, the latter being much more accepted than the former. The results

from the GJ also showed that structure type, as well as the presence of a plural non-dative in the cluster, has an effect in the native speakers' perception of clitic clusters. Specifically, clusters containing a reflexive are accepted at much higher rates than clusters without reflexives. The presence of a non-argumental dative is not a determining factor for the acceptance or rejections of a cluster. In fact, we have seen that structures with argumental and non-argumental datives show similar patterns (ACC-NAD behaved similarly to DAT-NAD and REFL-DAT behaved similarly to REFL-NAD), which implies that they are both subject to the same restrictions. The presence or absence of a reflexive, by contrast, proved a much better indicator of whether the cluster will be accepted or not. These findings further strengthen the proposal that both morphology and syntax play a role in clitic restrictions. In turn, they open questions on the status of reflexives and their effect on clitic cluster constraints.

Finally, the existence of high raters and low raters is a clear indicator of variability within the language. This is consistent with the apparent variability in the acceptance of 1st/2nd person clusters in Italian observed by several authors (Bonet 1991; Nicol 2005; Bianchi 2006), as well as with the fact that some authors argue for the acceptability of 1st and 2nd person clusters in Spanish (e.g. Bonet 1991) while other authors argue against it (e.g. Ormazábal and Romero 2007).

Experiment 2 consisted of an on-line self-paced reading task and the results also provide further support for the FMC and the NPBE. Overall, we saw that the fastest reading times correspond to the grammatical conditions and the slowest reading times corresponded to the *NPBE ungrammatical conditions. The experiment contained five conditions which could be grouped into three: grammatical, *NPBE (NPBE violation) and *syntactic (agreement mismatch). In

addition, the experiment also contained two types of structure: REFL-NAD and REFL-DAT. Even though the trends were visible in all comparisons, the effects of clitic cluster on reading times were more apparent when the conditions were grouped and the two structure types were collapsed. Thus, in the overall results, we found significant differences between the grammatical and the *NPBE conditions, as well as between the *NPBE conditions and the syntactic violation.

The results of experiment 2 indicate that, in Spanish, clitic cluster constraints trigger processing effects and that the parser is sensitive to violations of clitic restrictions such as the NPBE. In addition, the results also suggest that different types of ungrammaticality produce different effects and that NPBE violations seem to be more taxing for the parser, since they yielded longer reading times than any other condition.

In an attempt to better understand clitic phenomena and the mental processes associated with them, Chapter 5 explores the learnability of clitic restrictions in Spanish and the effects of the L1 when it comes to the acceptance/rejection and processing of clitic clusters in an L2. Specifically, the following chapter presents and analyzes the results of the two experiments discussed in this chapter, namely the scaled grammaticality judgment task and the on-line self-paced reading task, administered to three groups of advanced speakers of Spanish whose L1s are English, French and Romanian, respectively.

5. SECOND LANGUAGE ACQUISITION OF CLITIC RESTRICTIONS: REPRESENTATION, PROCESSING AND LEARNABILITY

As we have seen in previous chapters of the dissertation, a challenging characteristic of clitic restrictions is that they are applied differently in different languages and, as such, combinations that are acceptable in some languages are unacceptable in others. Such is the case for the sentences in example (3) of Chapter 1, repeated here as (1) for convenience.⁹⁹

- (1) a) Tú **te** **me** presentaste en la fiesta.
You 2.SG.ACC 1.SG.DAT introduced at the party
- b) *Tu **te** **m'es** présenté à la fête.
You 2.SG.ACC 1.SG.DAT-PST introduced at the party¹⁰⁰
- 'You introduced yourself to me at the party'

⁹⁹ The accusative clitic in all the sentences in (1) and (2) can also be interpreted as a reflexive, which, in fact, is the preferred interpretation by native speakers, as noted in footnote 1 of Chapter 4.

¹⁰⁰ The French example has been assigned the Acc-Dat order in order to present parallel sentences in both Spanish and French. However, the ungrammaticality of the French sentence is not due to the order of the clitics, since the Dat-Acc ordering would also result in ungrammaticality in this case.

As we can see in (1), combinations of 1st and 2nd person clitics are allowed in Spanish, but not in French. This contrast between the two languages corresponds to Bonet's (1991) distinction between Strong and Weak PCC languages.¹⁰¹

In addition, we have seen that in Spanish, as well as in Romanian, the non-dative clitic of a cluster can never be plural, as shown in (2).

- (2) a) **Te** **me** presentaste en la fiesta. [Sp]
 2.SG.ACC 1.SG.DAT introduced at the party
- Mi** **te-ai** prezentat la petrecere. [Ro]
 1.SG.DAT 2.SG. ACC-PAST introduce at the party
 ‘You introduced yourself to me at the party’
- b) **Te** **nos** presentaste en la fiesta. [Sp]
 2.SG.ACC 1.PL.DAT introduced at the party
- Ni** **te-ai** prezentat la petrecere. [Ro]
 1.PL.DAT 2.SG. ACC-PAST introduce at the party
 ‘You introduced yourself to us at the party’
- c) ***Os** **nos** presentasteis en la fiesta. [Sp]
 2.PL.ACC 1.PL.DAT introduced at the party
- *Ni** **v-ați** prezentat la petrecere. [Ro]
 1.PL.DAT 2.PL. ACC-PAST introduce at the party
 ‘You introduced yourselves to us at the party’
- d) ***Os** **me** presentasteis en la fiesta. [Sp]
 2.PL.ACC 1.SG.DAT introduced at the party
- *Mi** **v-ați** prezentat la petrecere. [Ro]
 1.SG.DAT 2.PL.ACC-PAST introduce at the party
 ‘You introduced yourselves to me at the party’

¹⁰¹ See Chapter 1 (p. 9), for further discussion on Bonet's (1991) analysis of clitic restrictions.

In terms of the Feature Markedness Constraint (FMC) proposed in Chapter 2 of this dissertation, reproduced here in (3), French does not allow for combinations of two clitics that carry the [+person] feature, whereas Spanish does.¹⁰²

- (3) A. In a combination of clitics, a dative clitic cannot be outranked in terms of marked features by a non-dative clitic.
- B. The acceptability of two clitics that contain equally marked features is language-specific.

In short, in all three languages, combinations in which the dative clitic carries more marked features than the non-dative are ungrammatical, as shown in the contrast between (2b) and (2c). In turn, despite the fact that they allow combinations of two clitics that are equally marked for [person], Spanish and Romanian reject combinations in which the two clitics carry the [+plural] feature. This corresponds to the Narrow Plural-Blocking Effect (NPBE), discussed in Chapter 3.

These cross-linguistic differences raise a number of questions regarding the learnability of the different versions of clitic cluster constraints. Specifically, we may ask to what extent they are learnable, and whether the existence of a different version of the restriction in the learner's L1 will interfere with the correct acquisition of the restriction in the L2. Furthermore, it is particularly interesting that this is not an aspect that is formally taught in the classroom so, when confronted with clitic clusters, L2 speakers will most likely have to rely on their own intuitions.

¹⁰² See Chapter 2 (p. 9) for further discussion on the FMC account of the French data.

The notion of transfer

The above-stated questions specifically address the issue of cross-linguistic influence, or transfer, which has been the subject of substantial research in the field of Second Language Acquisition (SLA). Odlin (1989) defines transfer as “the influence resulting from the similarities and differences between the target language and any other language that has been previously (and perhaps imperfectly) acquired” (p. 27).¹⁰³ Furthermore, transfer may be positive or negative. Positive transfer occurs when characteristics of the languages are similar or, in terms of Siegel (2009, p. 578), when L1 features match those of the L2, in which case we find facilitation in the acquisition of the L2. On the other hand, when the characteristics of the L1 and the L2 differ or, again following Siegel (2009), when the features do not match, we find negative transfer, which results in interference during the L2 acquisition process.¹⁰⁴

In addition, three possibilities have been proposed with respect to the degree of transfer that may occur during the acquisition of an L2. At one end of the spectrum we have no transfer, which implies no influence of the L1 on the L2 (Flynn and Martohardjiono, 1994; Epstein, Flynn and Martohardjiono, 1996). At the opposite end we have full transfer, which assumes that all aspects of the L1 are transferred onto the L2, at least at the initial stages (Schwartz and Sprouse 1994, 1996). The third possibility is partial transfer, according to which only

¹⁰³ Whereas the term transfer may be used to indicate cross-linguistic influence in either direction, this chapter focuses on the influence of the L1 on the L2. This, in fact, coincides with the terminology used by authors such as Sharwood Smith (1996), who distinguishes between cross-linguistic influence (influence in either direction) and transfer (L1 influence on the L2).

¹⁰⁴ The notions of positive, neutral and negative transfer have been widely discussed in the literature. The reader is referred to Gass and Selinker's (1994) volume on language transfer for further discussion on this matter.

certain aspects are transferred between the L1 and the L2.¹⁰⁵ Whereas it is widely accepted that there is indeed transfer during the L2 acquisition process, at least to a certain degree, Sabourin, Stowe and de Haan (2006) explain that “proponents of partial transfer are not in agreement over what part of the L1 is transferred and what is not transferred” (p. 2).

L2 studies on Spanish clitics

Studies on clitics in L2 Spanish have traditionally focused on a number of characteristics which include clitic placement (Liceras 1985), clitic raising (Bruhn de Garavito and Montrul, 1996; Duffield and White, 1999), clitic left dislocation (Valenzuela 2006), clitic doubling (Bruhn de Garavito 2006), the use of clitics with causative constructions (Duffield and White, 1999), and the acquisition of constructions associated with dative clitics (Montrul, 1999), to name only a few representative studies within the generative tradition. In all of these studies the results indicated that the acquisition of the clitic properties in Spanish was successful for the most part, but a certain degree of transfer from the L1 was also identified, often in the case of native speakers of French. For example, we have interference from the L1 in the case of Liceras (1985), and facilitation in the case of Montrul (1999).

Guijarro-Fuentes and Ortiz-López (2008) studied the L2 acquisition of Spanish clitics by L1 speakers of Haitian Creole. Specifically, using spontaneous data, they analyzed morphosyntactic properties of clitics such as agreement in the interlanguage of these speakers. The authors, who also found interference from the

¹⁰⁵ See White (2000, 2003a, 2003b) for a discussion of the literature dealing with the degrees of transfer and accessibility to Universal Grammar in second language acquisition.

L1, conclude that there is dissociation between syntax and morphology, given the fact that, whereas syntactic properties seem to be successfully acquired, morphological properties are rather problematic for the L2 speakers.¹⁰⁶

Learnability, transfer and clitic restrictions in L2 Spanish

As discussed in Chapter 4, the great interest that clitic restrictions have raised in linguistic theory has not translated into an emergence of experimental studies on the phenomenon. As such, to the best of my knowledge, the study of clitic cluster constraints from an L2 acquisition perspective remains unexplored.

The two experiments presented in this chapter, namely a scaled grammaticality judgment task and an on-line self-paced reading task, seek to fill this gap and point towards new paths of investigation that incorporate the language acquisition perspective to the ongoing research on clitic cluster phenomena. Specifically, the two experiments provide experimental data from three groups of advanced L2 speakers of Spanish whose native languages are Romanian (Weak PCC and NPBE, like in Spanish), French (strong PCC) and English (no comparable structure). In addition, the data from native speakers presented and discussed in Chapter 4 serve as the native control group.

The L2 learning process of these constructions includes, first, the incorporation of the clitic category and its properties and, second, the setting of the adequate clitic cluster restriction. In the case of L1 French and L1 Romanian, the clitic category is already present in their L1, in contrast with L1 English speakers, who have to learn this new category in their L2. The results of available studies on

¹⁰⁶ The notion of dissociation between morphology and syntax in SLA has been defended by many authors, including Lardiere (1998) and Prevost and White (1998), among others.

L2 Spanish, as discussed in the previous sub-section, indicate that the properties of Spanish clitics are acquired more or less successfully by L2 speakers.

With respect to cluster restrictions, no L2 data are available to date. If the rejection of clusters in which the non-dative is more marked than the dative, as expressed in the FMC, corresponds to a universal constraint and assuming that L2 learners have access to Universal Grammar (UG), none of the L2 groups should accept sentences that violate the FMC. In contrast, the NPBE is language-specific, which implies that access to UG is not enough to acquire the version of cluster restriction specific to Spanish.

In the case of L1 English, the acquisition of cluster restrictions, in this case the NPBE, is added to the general acquisition process of the clitic category.

In the case of L1 French, the speakers will have to reorganize the restrictions available to them in their L1 and modify them to accommodate to a different version in their L2, in this case, a less restrictive one, since Spanish accepts clusters that are not allowed in French. Along the lines of Lardiere's (2009) feature reassembly proposal, L1 French speakers have to restructure the relative acceptance of the presence of certain marked features in the cluster, since Spanish allows for structures that are not possible in French.

In the case of L1 Romanian, the same version of the restriction applies in both their L1 and their L2 regardless of the fact that Romanian and Spanish clitic clusters display different linear orders. Therefore, they do not need to learn or "reassemble" the version of the restriction that is already available to them through their L1.

In sum, besides the study of the learnability of clitic restrictions, and beyond access to UG, the use of these particular L1s allows us to explore the extent to which the L1 may influence the acceptance and processing of clitic clusters in the L2.

Section 5.1 presents the scaled grammaticality judgment task and section 5.2 presents the on-line self-paced reading task. In both sections, each L2 group is discussed individually, followed by a comparison between the native and non-native groups.

5.1. SCALED GRAMMATICALITY JUDGMENT TASK

In order to test the non-native perception of 1st and 2nd person clitic combinations, the scaled grammaticality judgment task presented in Chapter 4 was administered to three groups of L2 speakers of Spanish. Given the dialectal differences between the Peninsular and the Latin American variants of Spanish, special care was taken to ensure that all the L2 learners had been exposed to the Peninsular variant and that they were all familiar with the use of *vosotros/os*.

5.1.1. Research Questions

This experiment aims to answer three main research questions. First, are clitic restrictions, particularly the ones derived from the FMC, learnable? Can such restrictions be grasped by non-native speakers?

Second, will the judgments of 1st and 2nd person clitic combinations by L2 speakers of Spanish coincide with those provided by native speakers? Specifically, will non-native speakers reject all clusters in which the non-dative outranks the

dative, as predicted by the FMC? Will non-native speakers reject two plural 1st-2nd clitic clusters, as predicted by the NPBE, a language-specific restriction? And, finally, given the results reported in Chapter 4, will non-native speakers show higher acceptance rates in the case of clusters that contain a reflexive?

Third, will non-native speakers transfer the specific clitic restrictions of their L1 onto their L2? To what extent will the L1 influence their perception of L2 clitic combinations?

5.1.2. Hypotheses

As we have seen in Chapter 4, available data from native speakers of Spanish show very strong preferences that align with the predictions made by the FMC and the NPBE. This was also the case for the Romanian participants from Nevins and Săvescu's (2010) study. Specifically, these two groups of native speakers showed, on the one hand, a very strong tendency to reject clitic combinations in which the non-dative clitic is plural and, on the other hand, much higher acceptance of clusters in which the non-dative is singular.

As discussed above, existing studies dealing with the L2 acquisition of Spanish clitics show that non-native speakers seem to have acquired a variety of characteristics associated with these pronouns. Nevertheless, some indicators of interference from the L1 are also present in the data.

Thus, a number of predictions can be made based on the predictions made by the FMC and the NPBE, the results from native speakers of Spanish and Romanian and the available studies dealing with the L2 acquisition of clitics. First, the results should indicate a general tendency to reject clusters that are not

sanctioned by the FMC, i.e. clusters where the non-dative clitic outranks the dative one. In addition, influence from the L1 is also to be expected. As such, if L2 speakers rely on their L1 to judge clitic combinations in their L2, we expect the Romanian group to perform like native speakers. In turn, the French group will tend to reject all combinations of 1st and 2nd person clitics, including the ones that are grammatical in Spanish, since none of these combinations are acceptable in their L1. Finally, the English group will not be able to rely on their L1, since there are no clitics in English, so no predictions of L1 transfer can be provided for this group. Despite the fact that no predictions based on transfer are available for this group, L1 English speakers are nevertheless expected to reject combinations in which the non-dative outranks the dative, if we assume both the universality of this restriction and access to UG by L2 speakers.

5.1.3. *Experimental design, materials and procedure*

As indicated in the previous section, the same scaled grammaticality judgment task was distributed to both native and non-native speakers. A brief summary of the experimental design, materials and procedure is provided below.¹⁰⁷

Three groups of advanced L2 speakers of Spanish took part in the experiment. Only advanced speakers were considered because the target structure implies a level of grammatical complexity that goes beyond beginner and intermediate levels of proficiency. Their level of proficiency was assessed based on their placement in their corresponding institutional setting as well as on the results of a cloze test which was distributed to all non-native speakers as part of

¹⁰⁷ The reader is referred to sections 4.1.3, 4.1.4 and 4.1.6 of Chapter 4 for a more detailed explanation of these aspects.

the pre-test documentation. Thus, the experiment consisted of two parts: a pre-test and the experimental task. During the pre-test phase, a language background questionnaire was administered to all groups, both native (control group) and non-native. In addition, all L2 groups were asked to complete a self-assessment questionnaire, in which the participants were asked to provide information about all the languages they spoke, and the aforementioned cloze test, which provided an independent measure of their proficiency level in Spanish.

The experimental phase corresponded to the actual scaled grammaticality judgment (GJ) task. The materials and procedures used for the non-native groups were the same as those used for the native group.

The task contained 96 items in total (32 experimental, 32 controls, 32 fillers) and all items had the same structure: first, a context sentence, followed by the target sentence which the participants had to judge. Each item was accompanied by a five-point Likert scale with values ranging from 1 ('sounds bad') to 9 ('sounds good').

There were four conditions per experimental item, which corresponded to the following clitic clusters: *te me* [2SG 1SG], *te nos* [2SG 1PL], *os nos* [2PL 1PL] and *os me* [2PL 1SG].

Finally, the experiment included four structure types, namely accusative and non-argumental dative (ACC-NAD), as in (4a); dative and non-argumental dative (DAT-NAD), as in (4b); reflexive and non-argumental dative (REFL-NAD), as in (4c) and reflexive and dative (REFL-DAT), as in (4d).¹⁰⁸

¹⁰⁸ These sentences, repeated here for the reader's convenience, correspond to those in (4), in Chapter 4.

- (4) a) Ellos **te** **me** empujan
 They 2.SG.ACC 1.SG.NAD push
 ‘They push you (and I’m affected by it)’
- b) Ellos **te** **me** pintan la cara
 They 2.SG.DAT 1.SG. NAD paint the face
 ‘They paint your face (and I’m affected by it)’
- c) Tú **te** **me** enfermas
 You 2.SG.REFL 1.SG.NAD get.sick
 ‘You get sick (and I’m affected by it)’
- d) Tú **te** **me** presentaste
 You 2.SG.REFL 1.SG.DAT introduced
 ‘You introduced yourself to me’

The four conditions and the four syntactic structures of the experimental items were distributed into four lists and randomized using a Latin Square design.

Participants had to rate all the items according to the five-point scale included below each item. In the case of items rated with the lower scores of the scale, participants were instructed to highlight the part of the target sentence that sounded bad. Participants were not required to provide a correct alternative for the bad sentences in order to prevent any modifications to the original judgment if the participant was not able to come up with a better alternative to the bad sentence. The complete experiment, including both the pre-test and the GJ task, took between 75 and 90 minutes to complete.

5.1.4. Results and discussion

The following sections include the results of the non-native results followed by a comparison of the three L2 groups and the native speakers. As indicated above, each L2 group is discussed individually.

5.1.4.1. L1 English

Participants

26 persons volunteered to participate in the study. The data from five participants had to be rejected because their L1 was not English and the data from one more participant had to be rejected because the person only completed a fraction of the experimental task. This left a total number of 20 participants whose data were retained for analysis. All 20 participants were native speakers of English and seven of them only spoke English and Spanish. Other languages that the participants spoke included: French (9), Chinese (1), Arabic (1) and Latvian (1).¹⁰⁹ All the participants confirmed that their dominant language was English, which was also the language they used most regularly and the one with which they were most comfortable at the time of testing. The participants were recruited at the University of Ottawa, Canada, (N=12) and Instituto Cervantes in London, England (N=8).

The mean age for the group was 29.78, with ages ranging from 19 to 50. The mean score for the cloze test was 13.95 out of 20 and there were 17 female and 3 male participants.

¹⁰⁹ Given the impossibility to find a representative number of pure L1 English- L2 Spanish speakers, and even more so in the case of L1 French and L1 Romanian, exposure to other languages was not considered a parameter for participant exclusion as long as the native and dominant language was English, French or Romanian.

Results

The results of the grammaticality judgment task from the English group are detailed below. I first report the overall results and then I present the different structure types separately.

Table 5.1. Total mean ratings from the English group (experimental items)

CLUSTER	MEAN	ST. DEV.
<i>te me</i>	3.09	1.1741
<i>te nos</i>	3.30	1.258
<i>os nos</i>	3.57	1.767
<i>os me</i>	3.77	1.349

Table 5.1, above, provides the mean and standard deviation values for each cluster and Figure 5.1 shows the overall results from the experimental items with respect to cluster type, according to the data reported on table 5.1.

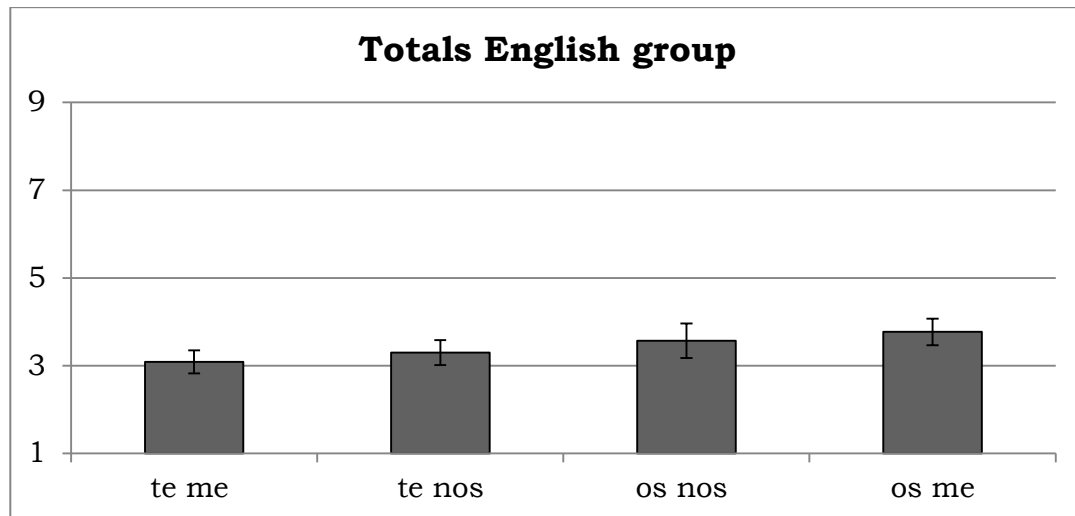

Figure 5.1. Total average results from the English group by cluster type¹¹⁰

¹¹⁰ All the figures in this chapter include error bars using standard error.

As we can see in the table and graph above, the overall acceptance of the four clusters remains rather low, with an average score between 3 and 4 for each cluster. Contrary to expected, the mean rate is actually higher for the ungrammatical clusters than for the grammatical ones. In order to verify whether these differences were statistically significant, a 4x4 repeated measures Analysis of Variance (ANOVA) with cluster type and structure type as the within-subjects factors was performed on these data.

The results of the ANOVA show no main effect for Cluster ($F(3,57)=1.980$, $p=.127$) and there was no significant interaction between Cluster and Structure ($F(9,171)=.678$, $p=.728$). There was, however, a main effect for Structure ($F(3,57)=28.560$, $p<.001$). In view of these results, we now turn to the analysis of the results by structure type.

Table 5.2. Total ratings from the English group by structure type

CLUSTER	ACC-NAD		DAT-NAD		REFL-NAD		REFL-DAT	
	MEAN	ST. DEV	MEAN	ST. DEV	MEAN	ST. DEV	MEAN	ST. DEV
<i>te me</i>	1.83	1.48	1.48	0.716	4.35	2.498	4.7	2.793
<i>te nos</i>	2.55	1.849	1.65	1.137	3.95	2.164	5.2	3.122
<i>os nos</i>	2.4	1.875	2.5	2.212	4.2	2.397	5.28	2.603
<i>os me</i>	3.05	2.064	2.58	2.008	4.1	2.532	5.25	2.673

Table 5.2, above, and Figure 5.2, below, show the breakdown of the different structure types for the English group.

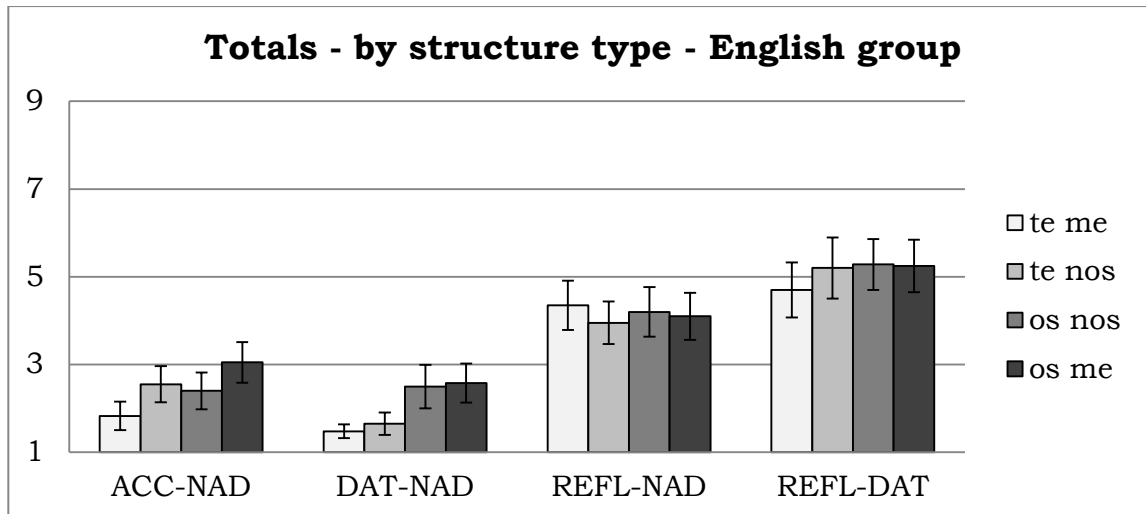

Figure 5.2. Total average results from the English group by structure type

As we saw above, there are no significant differences in the treatment of the four clusters and there was no interaction between Cluster and Structure. However, the four structures are treated differently. Specifically, those containing a reflexive clitic received much higher scores, regardless of the cluster that appeared in the sentence. In fact, pairwise comparisons reveal that the differences between ACC-NAD and DAT-NAD, as well as between REFL-NAD and REFL-DAT are not significant ($p=.963$ and $p=.196$, respectively).¹¹¹ In turn, the differences are significant between ACC-NAD and REFL-NAD on the one hand ($p<.001$), and between ACC-NAD and REFL-DAT on the other hand ($p<.001$). Similarly, the differences are significant between DAT-NAD and REFL-NAD on the one hand ($p<.001$), and between DAT-NAD and REFL-DAT on the other hand ($p<.001$).

In sum, all four clusters are treated similarly across structure types. In turn, the non-reflexive structures (ACC-NAD; DAT-NAD) received lower scores than

¹¹¹ As in Chapter 4, all pairwise comparisons were performed using the Bonferroni correction.

the reflexive structures (REFL-NAD; REFL-DAT), a difference which was statistically significant.

The English group differs from the native group in the acceptance patterns of the different clusters, since the clear-cut distinction between grammatical and ungrammatical clusters as well as the strong tendency to reject ungrammatical clusters is not found in the L1 English data. The two groups, however, display some similarities in the treatment of the different structure types. Thus, as in the case of the L1 Spanish group, reported in Chapter 4, the results of the L1 English group show a clear-cut distinction between clusters with reflexives and clusters without reflexives. As shown in Table 5.3 and Figure 5.3, below, the differences are more apparent when the results are grouped according to reflexivity.

Table 5.3. English group results for the NON-REFL and REFL conditions

CLUSTER	NON-REFL		REFL	
	MEAN	ST. DEV	MEAN	ST. DEV
<i>te me</i>	1.65	0.978	4.525	1.8812
<i>te nos</i>	2.1	1.142	4.54	2.168
<i>os nos</i>	2.45	1.813	4.69	2.19
<i>os me</i>	2.81	1.388	4.73	1.736

Table 5.3, above, provides the mean and standard deviation values for both the non-reflexive and the reflexive types and Figure 5.3, below, shows the results according to the data reported on Table 5.3.

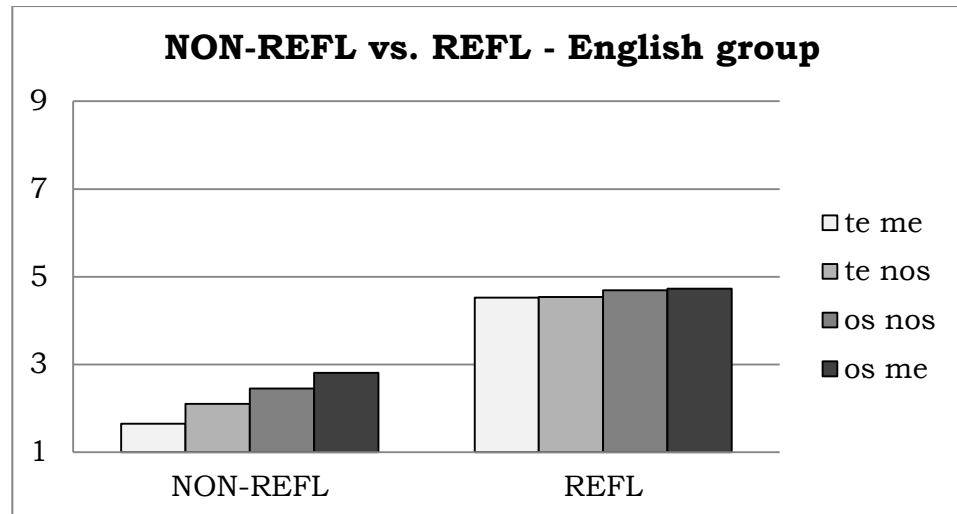

Figure 5.3. Average English group results for the NON-REFL and the REFL structures

As expected, the results of a 2x4 repeated measures ANOVA with Reflexivity and Cluster as the within-subjects factors show a main effect for Reflexivity ($F(1,19)=61.493, p<.001$). In turn, the differences between the different clusters are not significant ($F(3,57)=2.023, p=.121$) and the interaction between Reflexivity and Cluster was not significant either ($F(3,57)=1.198, p=.319$).

These results show that, as in the case of the native speakers, the English participants are sensitive to structure type, as they show a preference for clusters that contain a reflexive clitic. However, when it comes to cluster type, a different pattern emerges. Specifically, the English group seems to provide higher ratings to the ungrammatical clusters than to the grammatical ones. Even though the differences between clusters were not statistically significant, this pattern contrasts sharply with the predictions made by the FMC and the NPBE, as well as with the native results. However, the differences between the four cluster types are not significant, which suggests that the English group is not sensitive to the restrictions of the FMC and the NPBE.

It is also worth noting that the highest ratings cluster around 5, which is the value that corresponds to an “undecided” response. Nevertheless, as we can see in Figure 5.4, this does not mean that the participants responded with a 5 to most of the items. In fact, participants committed to a positive or negative rating in most cases. Specifically, 5 is the least used value in the scale and it does not reach 10% in any of the clusters. However, the distribution of positive and negative responses was somewhat similar, which caused the means to cluster around the middle point of the scale.

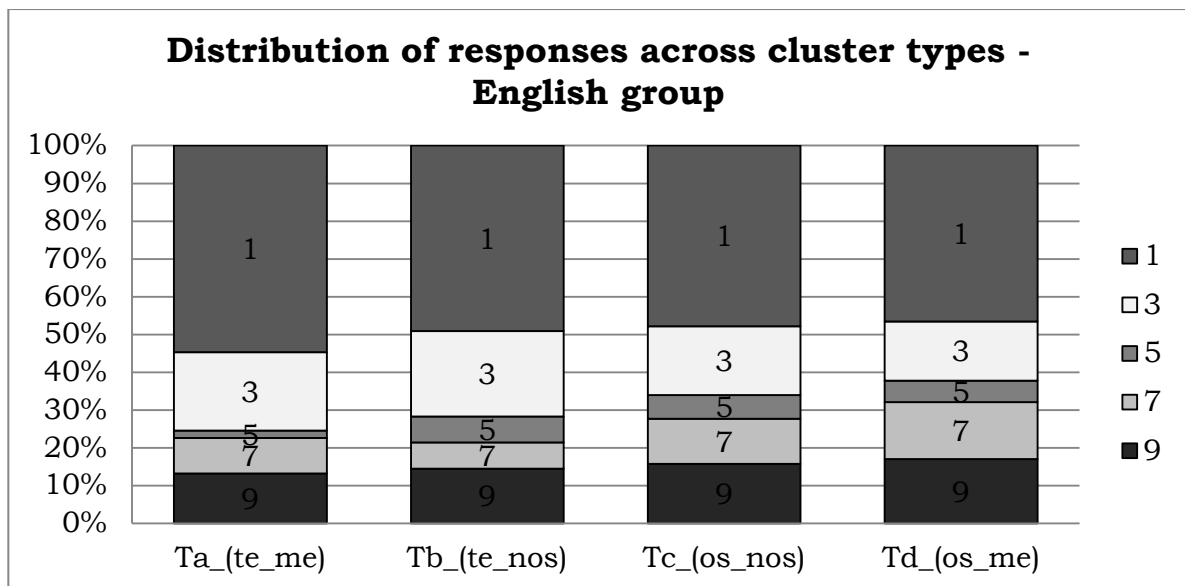

Figure 5.4. Distribution of responses from the English group across cluster types

A similar effect was found with the Spanish group and further analysis revealed two trends in the participants’ responses. Specifically, it was possible to differentiate between “high raters”, who tended to give higher scores to the grammatical clusters and “low raters”, who tended to give lower scores to all clusters. In the case of the English group, this distinction is not clear-cut and the

high and low ratings seem to be similarly distributed across participants. In other words, and as opposed to the native group, we have more variability in the overall response distribution across clusters and also across participants.

With respect to the response distribution, it is particularly noteworthy that this variability is more prominent in the case of the ungrammatical clusters, which consequently results in higher overall ratings. This seems to indicate that the responses of the English group are more likely to be the result of uncertainty in the judgments of these structures than an actual preference for ungrammatical clusters.

Preliminary analysis on the individual differences did not show a clear pattern of high raters and low raters as consistent as in the case of the native group. Thus, in order to determine whether or not there may be a connection between the level of proficiency and the results of the GJ task, a series of regression analyses were performed on the L1 English data using the cloze test score and the results of the GJ task. The results of the regression analyses do not reveal a significant correlation between the score on the cloze test and any of the cluster rates.¹¹²

To summarize the results of the English group, we can see, on the one hand, that the English group is sensitive to the different structure types. Specifically, participants show significantly more acceptance of structures with reflexives than of structures without reflexives. On the other hand, there is not a difference in the acceptance of the different clitic clusters. These results suggest that the L1English

¹¹² In the case of the regression analysis, only the *F*- and *p*-values that correspond to statistically significant differences are reported.

group is sensitive to the different structure types, but not to the restrictions associated with the FMC and the NPBE.

5.1.4.2. L1 French

Participants

23 persons volunteered to participate in the study. The data from two participants had to be rejected, in one case, because the participant's L1 was not French and, in the other case, because the participant only completed a fraction of the experimental task. This left a total number of 21 participants whose data were retained for analysis. All 21 participants were native speakers of French and all of them reported having knowledge of English. Other languages that the participants spoke included: German (3), Arabic (2), Italian (2) and Creole (1). The other participants only spoke French and Spanish. All the participants confirmed that their dominant language was French, which was also the language they used most regularly and the one with which they were most comfortable at the time of testing. The participants were recruited at the University of Ottawa, Canada, (N=3) and Instituto Cervantes in Paris, France (N=18).

The mean age for the group was 51.72, with ages ranging between 20 and 79. The mean score for the cloze test was 16.90 out of 20 and there were 14 female and 7 male participants.

Results

The GJ results from the French group are detailed below. I first report the overall results and then present the different structure types separately.

Table 5.4. Total mean ratings from the French group (experimental items)

CLUSTER	MEAN	ST. DEV.
<i>te me</i>	3.1865	1.3421
<i>te nos</i>	3.52	1.201
<i>os nos</i>	4.21	1.965
<i>os me</i>	3.99	1.779

Table 5.4, above, provides the mean and standard deviation values for each cluster and Figure 5.4 shows the overall results from the experimental items with respect to cluster type, according to the data reported in Table 5.4.

As we can see, the overall scores from the French group, while relatively low, are higher than those from the native group and the highest rated clusters are the ungrammatical ones, which also contrasts with the native group.

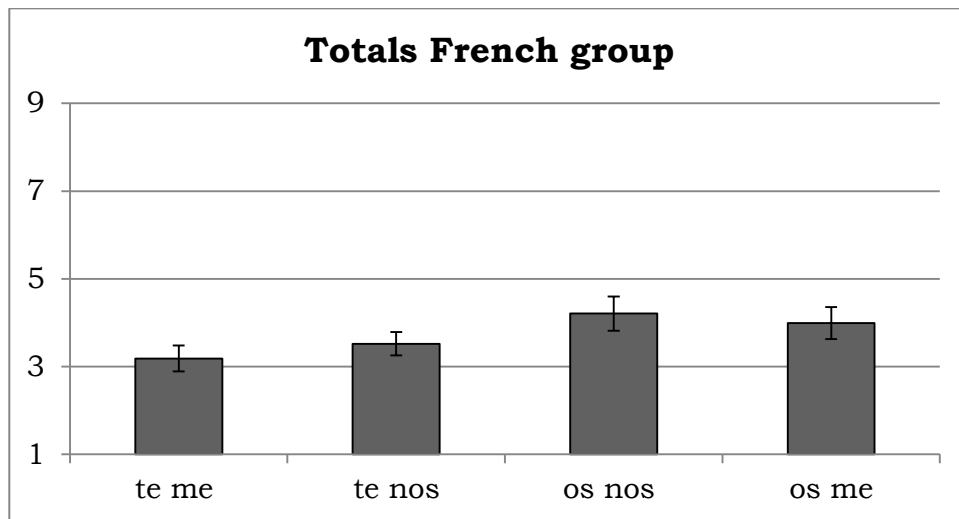

Figure 5.5. Total average results from the French group by cluster type

A 4x4 repeated measures ANOVA with cluster type and structure type as the within-subjects factors was performed on these data. The results of the ANOVA

show that there was a main effect for cluster type: $F(3,60)=34.599$, $p<.001$, which means that, in contrast with the English group, the differences between the four clusters are significant. In the case of the French group, the ungrammatical clusters received significantly higher scores than the grammatical ones. This also contrasts with the Spanish group, who assigned significantly lower scores to the ungrammatical clusters.

The ANOVA also reveals a main effect for structure type: $F(3,60)=3.317$, $p=.026$, which we have seen for the Spanish and English groups as well. There was, however, no significant interaction between the cluster and structure factors $F(9,180)=1.291$, $p=.244$.

In order to further explore the main effects revealed by the ANOVA, we now turn to the analysis by structure type.

Table 5.5. Total ratings from the French group by structure type

CLUSTER	ACC-NAD		DAT-NAD		REFL-NAD		REFL-DAT	
	MEAN	ST. DEV	MEAN	ST. DEV	MEAN	ST. DEV	MEAN	ST. DEV
<i>te me</i>	1.62	1.465	2.24	1.895	4.79	2.601	3.93	2.794
<i>te nos</i>	2.48	1.965	1.62	1.024	5.26	3.089	4.6	2.267
<i>os nos</i>	2.88	1.974	2.64	2.242	5	2.739	5.9	2.644
<i>os me</i>	2.5	1.936	2.98	2.411	4.76	2.606	5.38	2.819

Table 5.5, above, and Figure 5.6, below, show the breakdown of the different structure types for the French group.

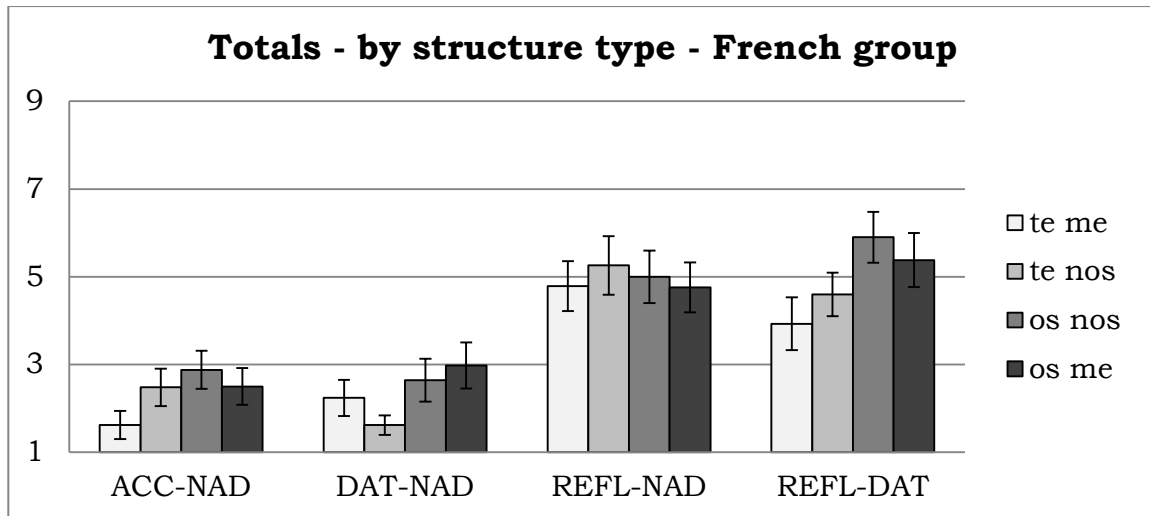

Figure 5.6. Total average results from the French group by structure type

As we can see, participants assigned higher scores to structure types that contain a reflexive. The acceptance patterns for singular and plural clusters is not consistent across structure types but, nevertheless, pairwise comparisons reveal no significant differences among the different cluster types ($p > .05$ in all cases). With respect to structure type, however, pairwise comparisons reveal significant differences between ACC-NAD and REFL-NAD, between ACC-NAD and REFL-DAT, between DAT-NAD and REFL-NAD and between DAT-NAD and REFL-DAT ($p < .001$ in all cases). As we saw with the English group, the reflexive and the non-reflexive conditions are treated differently and these differences are statistically significant.

Given the significant differences among structures, which show a clear effect of reflexivity, we now present the French results grouped into reflexive and non-reflexive structures.

Table 5.6. French group results for the NON-REFL and REFL conditions

CLUSTER	NON-REFL		REFL	
	MEAN	ST. DEV	MEAN	ST. DEV
<i>te me</i>	1.98	1.473	4.35	2.289
<i>te nos</i>	2	1.17	4.95	2.176
<i>os nos</i>	2.88	2.4	5.38	2.139
<i>os me</i>	2.65	1.639	5.08	2.214

Table 5.6, above, provides the mean and standard deviation values for both the non-reflexive and the reflexive types and Figure 5.3, below, shows the results according to the data reported on Table 5.7.

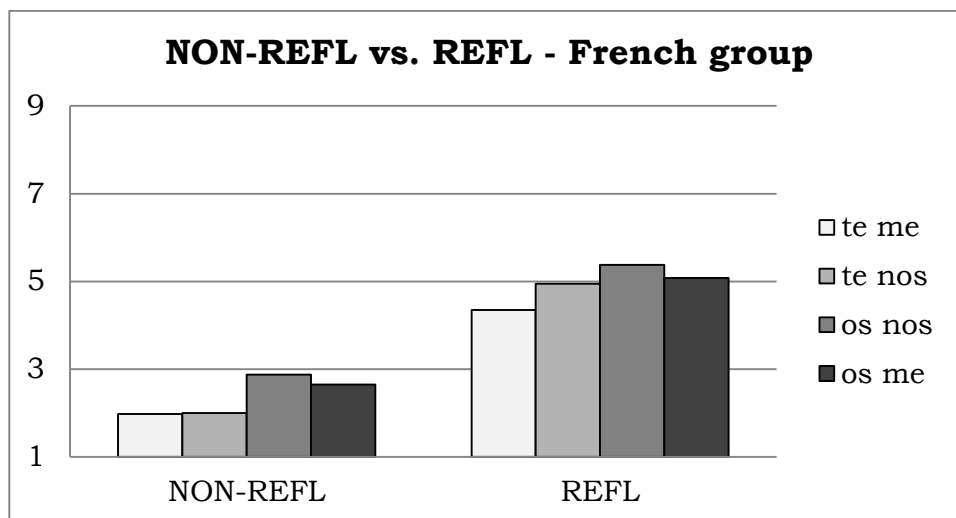

Figure 5.7. Average French group results for the NON-REFL and the REFL structures

The results of a 2x4 repeated measures ANOVA with Reflexivity and Cluster as the within-subjects factors revealed a main effect for Reflexivity ($F(1,20)=50.847$, $p<.001$) and a main effect for Cluster type ($F(3,60)=3.317$, $p=.026$). There was, however, no significant interaction between Cluster and Reflexivity ($F(3,60)=.570$, $p=.63$). These results indicate that the four clusters were treated differently

depending on whether the structure contained a reflexive or not. Specifically, higher scores were assigned to all clusters when their structure type included a reflexive pronoun. The lack of significance for the interaction between the two factors indicates that the clusters were not treated differently due to differences in the structure type.

These results, as in the case of the English group, are in contrast with the predictions made by the FMC and the NPBE and also differ from the native results. On the other hand, highest scores provided by the French participants remain around 5, which is the neutral value of the scale. However, this is an effect of averaging high and low rates, as we can see in Figure 5.8, which also shows the amount of variability in the responses, particularly in the case of the ungrammatical clusters.

As in the case of the English group, we have variability, both overall and also within participants. In order to determine whether this variability may be attributed to different levels of proficiency among the participants, a series of regression analyses were performed on the French data using the cloze test score and the results of the GJ task.

The results of the regression analyses reveal a significant correlation between the score on the cloze test and the cluster rates in the case of the ungrammatical clusters (*os nos* and *os me*) both in the reflexive and the non-reflexive structures (as well as overall). Specifically, in the case of *os nos* (overall), the results reveal a correlation of .708 ($r^2 = .501$), which is significant at $\alpha = .05$ ($F(1,19) = 19.055$, $p < .001$); slope = $-.519$ ($t(19) = -4.365$, $p < .001$). In the case of *os me* (overall) we find a correlation of .815 ($r^2 = .664$), which is significant at $\alpha = .05$

($F(1,19)=37.610, p<.001$); slope = $-.541 (t(19)=-6.133, p<.001)$. The same significant correlations were found for both the reflexive and non-reflexive structures.

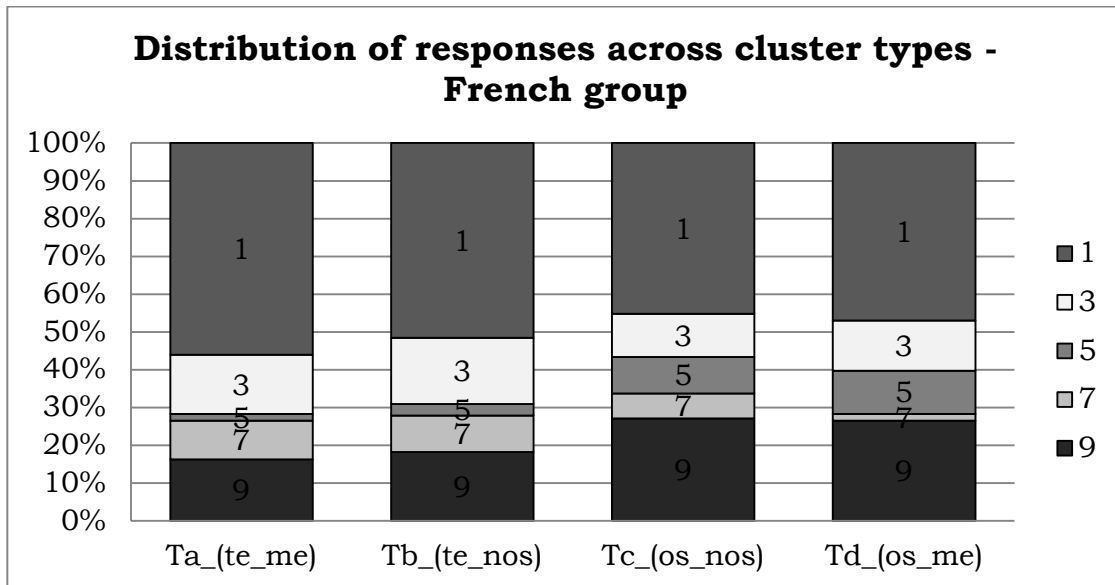

Figure 5.8. Distribution of responses from the French group across cluster types

As revealed by the regression analyses, we find a pattern of high raters and low raters that is related to the level of proficiency of the French participants, but only in the case of the ungrammatical clusters. The participants with the highest scores in the cloze test tended to assign lower values to the ungrammatical clusters than participants with lower scores in the cloze test. This trend was not found for the grammatical clusters. These results seem to indicate that participants with higher cloze test scores behave somewhat similarly to the native group, with a wide range of ratings for the grammatical clusters and a tendency to reject the ungrammatical clusters. Participants with lower cloze test scores seem to pattern with the English group with a varied distribution of ratings for both the grammatical and the ungrammatical clusters.

As in the case of L1 English, the French participants seem to be sensitive to structure type, showing a preference for structures with reflexives, but not to the FMC and the NPBE. The French group show significant differences in treatment of the four cluster types, assigning higher scores to the ungrammatical clusters. This contrasts with the two restrictions as well as with the native results. However, a closer look at the data indicates that these higher scores do not necessarily represent a preference for ungrammatical clusters but rather increased uncertainty and, consequently, more variability in the participants' responses.

5.1.4.3. L1 Romanian

Participants

28 persons volunteered to participate in the experiment. All 28 participants were native speakers of Romanian and all of them reported having knowledge of English. Other languages that the participants spoke included: French (13), Portuguese (6), German (1), Catalan (1) and Japanese (1). All the participants confirmed that their dominant language was Romanian, which was also the language they used most regularly and the one with which they were most comfortable at the time of testing. All the participants were recruited at two universities in Bucharest, Romania, namely the University of Bucharest (N=16) and University Spiru Haret (N= 12).

The mean age for the group was 22.21, with ages ranging between 19 and 31. The mean score for the cloze test was 16.46 out of 20 and there were 27 female and 1 male participants.

Results

The GJ results from the Romanian group are detailed below. I first report the overall results and, then, I present the different structure types separately.

Table 5.7. Total mean ratings from the Romanian group (experimental items)

CLUSTER	MEAN	ST. DEV.
<i>te me</i>	5.7653	2.004
<i>te nos</i>	5.27	1.862
<i>os nos</i>	4.65	1.889
<i>os me</i>	4.28	1.646

Table 5.7, above, provides the mean and standard deviation values for each cluster and Figure 5.9 shows the overall results from the experimental items with respect to cluster type, according to the data reported in Table 5.7.

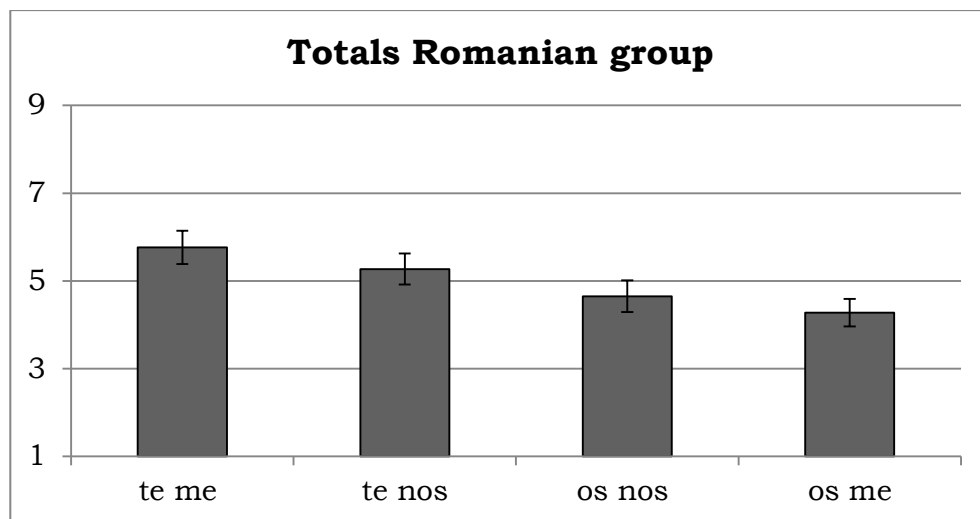

Figure 5.9. Total average results from the Romanian group by cluster type

The Romanian group displays the highest overall scores of all groups for all clusters, with values ranging between 4 and 6. In contrast with the English and the French groups, Romanian participants show higher acceptance rates for the

grammatical clusters than for the ungrammatical ones. In this respect, the Romanian group patterns with the Spanish group, who also showed higher scores for the grammatical clusters than for the ungrammatical ones.

A 4x4 repeated measures ANOVA with cluster type and structure types as the within-subjects factors was performed on the Romanian data. The results of the ANOVA reveal a main effect for Structure ($F(3,81)=20.523$, $p<.001$) as well as for Cluster ($F(3,81)=8.850$, $p<.001$). However, there was no significant interaction between the cluster and structure factors ($F(9,243)=1.534$, $p=.136$).

In order to further explore the main effects revealed by the ANOVA, we now turn to the analysis by structure type. Table 5.8 and Figure 5.10 show the breakdown of the different structure types for the Romanian group.

Table 5.8. Total ratings from the Romanian group by structure type

CLUSTER	ACC-NAD		DAT-NAD		REFL-NAD		REFL-DAT	
	MEAN	ST. DEV	MEAN	ST. DEV	MEAN	ST. DEV	MEAN	ST. DEV
<i>te me</i>	5.61	2.629	4.61	2.424	6.18	2.816	6.61	2.424
<i>te nos</i>	5.21	2.672	3.29	2.225	6.46	2.487	6.14	2.592
<i>os nos</i>	4.68	2.480	3.57	2.808	4.89	2.615	5.46	2.560
<i>os me</i>	3.57	2.456	3.50	2.186	5.04	2.202	5.11	2.558

As we have seen, the results of the 4x4 ANOVA reveal a main effect for both Cluster and Structure. With respect to Cluster, pairwise comparisons reveal significant differences between *te me* and *os nos* ($p=.021$), between *te me* and *os me* ($p=.001$) and between *te nos* and *os me* ($p=.025$). In these cases, the scores assigned to the grammatical clusters were significantly higher than those assigned to the ungrammatical clusters.

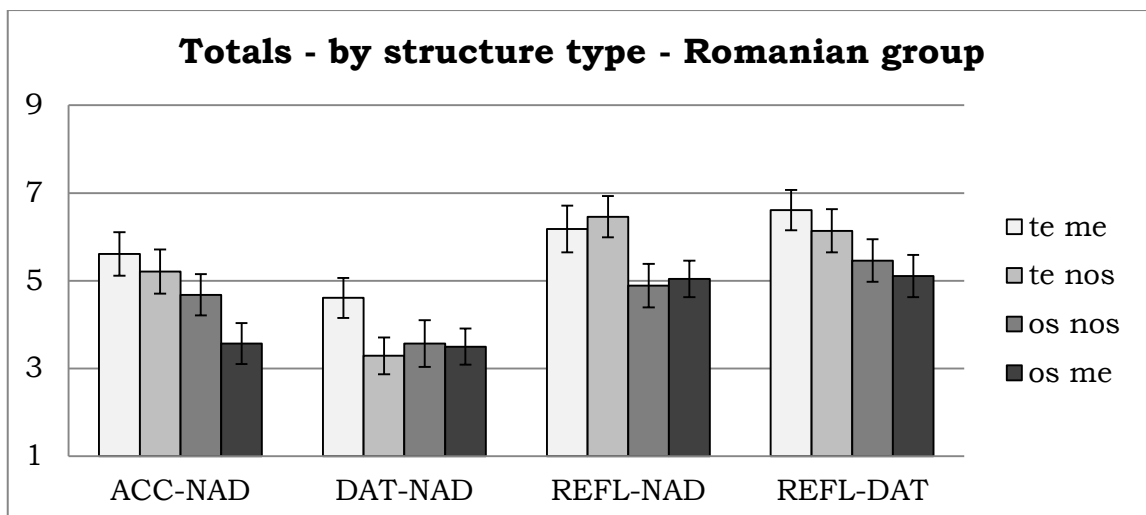

Figure 5.10. Total average results from the Romanian group by structure type

With respect to Structure, pairwise comparisons reveal significant differences between ACC-NAD and DAT-NAD ($p=.001$), between ACC-NAD and REFL-DAT ($p=.001$), between DAT-NAD and REFL-NAD ($p<.001$) and between DAT-NAD and REFL-DAT ($p<.001$).

Once again, we see that participants treated the four structures differently, assigning higher overall scores to structures with reflexives. Let us now analyze the Romanian results grouped into reflexive and non-reflexive structures.

Table 5.9. Romanian group results for the NON-REFL and REFL conditions

CLUSTER	NON-REFL		REFL	
	MEAN	ST. DEV	MEAN	ST. DEV
<i>te me</i>	5.11	2.229	6.417	2.1177
<i>te nos</i>	4.25	2.15	6.22	2.116
<i>os nos</i>	4.13	2.352	5.07	2.226
<i>os me</i>	3.53	2.062	5.05	1.951

Table 5.9, above, provides the mean and standard deviation values for both the non-reflexive and the reflexive types and Figure 5.11, below, shows the results according to the data reported in Table 5.9.

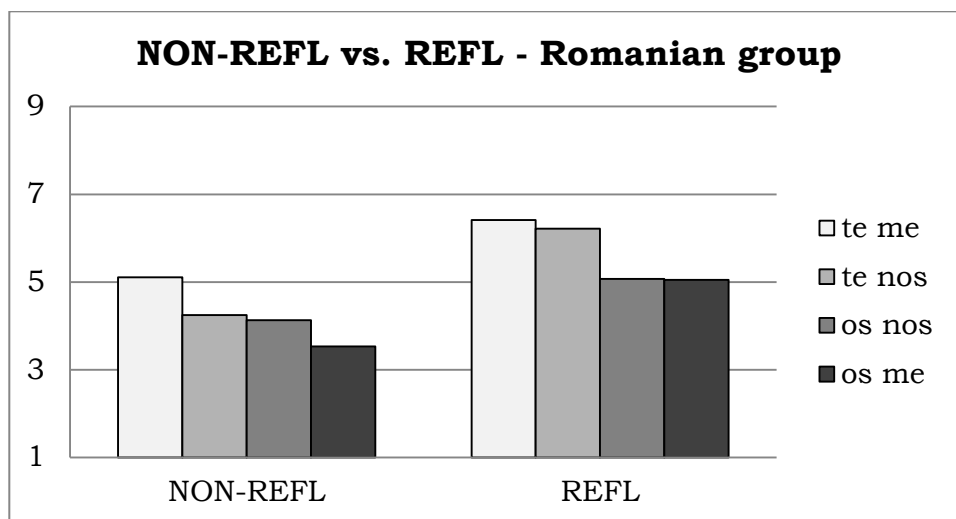

Figure 5.11. Average Romanian group results for the NON-REFL and the REFL structures

The results of a 2x4 repeated measures ANOVA with Reflexivity and Cluster as the within-subjects factors reveal a main effect for Reflexivity ($F(1,27)=29.646$, $p<.001$). The ANOVA also reveals a main effect for cluster type ($F(3,81)=9.311$, $p<.001$). Pairwise comparisons reveal significant differences between *te me* and *os nos* ($p=.013$), between *te me* and *os me* ($p=.001$) and between *te nos* and *os me* ($p=.032$). There was, however, no significant interaction between Reflexivity and Cluster ($F(3,81)=1.323$, $p=.273$).

The L1 Romanian results show a preference for structures with reflexives, which was also the case for L1 English and L1 French. However, in contrast with the other L2 groups, the Romanian group also shows a preference for grammatical clusters over ungrammatical ones, a pattern that is apparent with all structure

types. Despite the higher overall rates, these results pattern with the native results as well as with the predictions by the FMC and the NPBE.

As in the case of the two other L2 groups, we have variability, both overall and within participants. The general distribution of responses is presented in Figure 5.12.

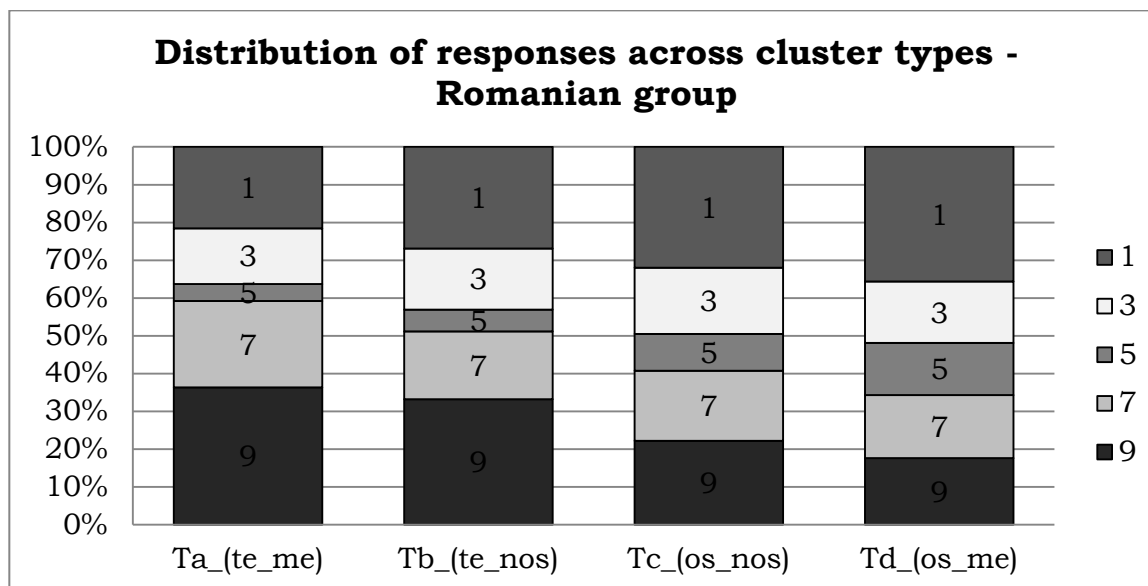

Figure 5.12. Distribution of responses from the Romanian group across cluster types

In order to determine whether this variability may be attributed to different levels of proficiency among the participants, a series of regression analyses were performed on the Romanian data using the cloze test score and the results of the GJ task. The results of the regression analyses reveal a significant correlation between the score on the cloze test and the GJ responses, but only for the grammatical clusters of the reflexive conditions. Specifically, in the case of *te me* (reflexive), the results reveal a correlation of .418 ($r^2 = .175$), which is significant at $\alpha = .05$ ($F(1,26) = 5.508$, $p = .027$); slope = .287 ($t(26) = 2.347$, $p = .027$). In the case of *te*

nos (reflexive), the results reveal a correlation of .422 ($r^2=.178$), which is significant at $\alpha=.05$ ($F(1,26)=5.626$, $p=.025$); slope =.289 ($t(26)=2.372$, $p=.025$). In these contexts, participants with the highest cloze test scores tended to give higher ratings than participants with lower scores.

As we have seen in this section, the Romanian group shares with the other three groups a statistically significant preference for structures with reflexives. However, the Romanian group provides the highest overall ratings of all four groups, including both native and non-native. In spite of this difference, both the Romanian and the Spanish groups show a similar pattern in that both groups display a statistically significant preference for grammatical clusters. This pattern is consistent with the FMC and the NPBE, despite the relatively high scores assigned to the ungrammatical clusters. This seems to indicate that the Romanian group is sensitive to both structure and cluster type.

5.1.4.4. Comparison between native and non-native data

After the analysis of each non-native group, I now compare the results of the native group, reported in Chapter 4, and the non-native groups. Table 5.10 provides a summary of the information of all the participants that were included in the study.

Table 5.10. GJ task participant information – All groups

Group (L1)	Participants	Mean age	Mean cloze test score	Females, Males
Spanish	24	35.62	N/A	16,8
English	20	29.78	13.95	17,3
French	21	51.72	16.90	14,7
Romanian	28	22.21	16.46	27,1

Table 5.11, below, includes the overall ratings for each group, including both the mean and the standard deviation.

Table 5.11. Total mean ratings from all groups (experimental items)

CLUSTER	SPANISH		ENGLISH		FRENCH		ROMANIAN	
	MEAN	ST. DEV	MEAN	ST. DEV	MEAN	ST. DEV	MEAN	ST. DEV
<i>te me</i>	3.33	1.51	3.09	1.17	3.19	1.34	5.76	2.00
<i>te nos</i>	3.16	1.63	3.30	1.26	3.52	1.20	5.27	1.86
<i>os nos</i>	1.32	.519	3.57	1.77	4.21	1.96	4.65	1.89
<i>os me</i>	1.11	.353	3.77	1.35	3.99	1.78	4.28	1.65

Figure 5.13, below, shows the overall results from the experimental items with respect to cluster type, according to the data reported in Table 5.11.

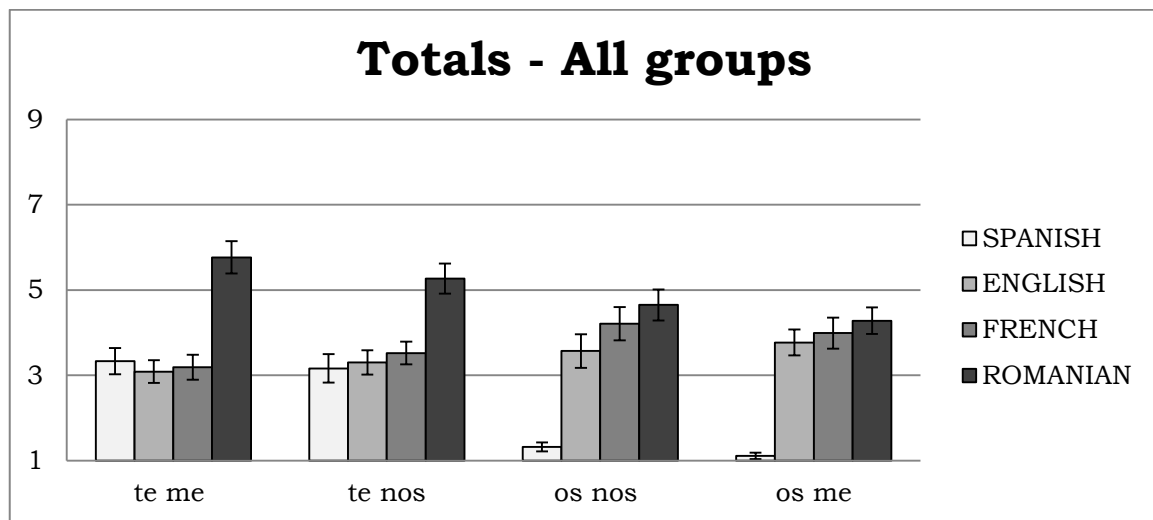

Figure 5.13. Total average results from all groups by cluster type

As we can see in Table 5.11 and Figure 5.13, the Spanish group displays the lowest overall ratings and the Romanian group displays the highest ratings of all groups in all cluster conditions. The acceptance of the grammatical clusters is similar for the Spanish, French and English groups. However, the treatment of

ungrammatical clusters is very different. In fact, the only group that rejects the ungrammatical clusters across the board is the Spanish group. The Romanian group, despite the fact that it rates the ungrammatical clusters higher than any other group, also assigns lower rates to the ungrammatical clusters than to the grammatical ones. In contrast, the English and, especially, the French groups show the reversed pattern, assigning higher rates to the ungrammatical clusters.

We now turn to the comparison between the four groups for each structure type. Tables 5.12 to 5.15 present a summary of the results from each group for each structure type. Figures 5.14 to 5.17 show the results for each structure type according to the data reported in Tables 5.12 to 5.15, respectively.

The results of a 3-way mixed ANOVA with Cluster and Structure as the within-subjects factors and group (L1) as the between-subject factor reveal a main effect for both Cluster ($F(3,267)=6.896$, $p<.001$) and Structure ($F(3,267)=120.800$, $p<.001$). The ANOVA also reveals a main effect for Group ($F(3,89)=21.324$, $p<.001$). All the interactions were also significant.

With respect to Cluster, pairwise comparisons reveal significant differences between *te me* and *os me* ($p=.005$) as well as between *te nos* and *os me* ($p=.005$). Regarding Structure, pairwise comparisons reveal significant differences between all four structures ($p<.05$ in all cases). Finally, in the case of Group, pairwise comparisons reveal significant differences between the native Spanish group and all the L2 groups ($p=.011$ for L1English, $p=.001$ for L1French and $p<.001$ for L1Romanian). As well, the differences between Romanian and the other two L2 groups were also significant ($p<.001$ for English and $p=.001$ for French). The differences between L1 English and L1 French were the only non-significant ones ($p=1.000$).

Table 5.12. Overall results for the ACC-NAD condition for all groups

CLUSTER	SPANISH		ENGLISH		FRENCH		ROMANIAN	
	MEAN	ST. DEV	MEAN	ST. DEV	MEAN	ST. DEV	MEAN	ST. DEV
<i>te me</i>	1.79	1.53	1.83	1.48	1.62	1.46	5.61	2.63
<i>te nos</i>	1.75	1.39	2.55	1.85	2.48	1.96	5.21	2.67
<i>os nos</i>	1.00	.000	2.40	1.87	2.88	1.97	4.68	2.48
<i>os me</i>	1.00	.000	3.05	2.06	2.50	1.94	3.57	2.46

Table 5.13. Overall results for the DAT-NAD condition for all groups

CLUSTER	SPANISH		ENGLISH		FRENCH		ROMANIAN	
	MEAN	ST. DEV	MEAN	ST. DEV	MEAN	ST. DEV	MEAN	ST. DEV
<i>te me</i>	1.38	.770	1.48	.716	2.24	1.89	4.61	2.42
<i>te nos</i>	1.42	.929	1.65	1.14	1.62	1.02	3.29	2.22
<i>os nos</i>	1.00	.000	2.50	2.21	2.64	2.24	3.57	2.81
<i>os me</i>	1.13	.612	2.58	2.01	2.98	2.41	3.50	2.19

Table 5.14. Overall results for the REFL-NAD condition for all groups

CLUSTER	SPANISH		ENGLISH		FRENCH		ROMANIAN	
	MEAN	ST. DEV	MEAN	ST. DEV	MEAN	ST. DEV	MEAN	ST. DEV
<i>te me</i>	4.63	2.50	4.35	2.50	4.79	2.60	6.18	2.82
<i>te nos</i>	4.33	2.70	3.95	2.16	5.26	3.09	6.46	2.49
<i>os nos</i>	1.58	1.18	4.20	2.40	5.00	2.74	4.89	2.61
<i>os me</i>	1.08	.408	4.10	2.53	4.76	2.61	5.04	2.20

Table 5.15. Overall results for the REFL-DAT condition for all groups

CLUSTER	SPANISH		ENGLISH		FRENCH		ROMANIAN	
	MEAN	ST. DEV	MEAN	ST. DEV	MEAN	ST. DEV	MEAN	ST. DEV
<i>te me</i>	5.54	2.57	4.70	2.79	3.93	2.79	6.61	2.42
<i>te nos</i>	5.12	2.64	5.20	3.12	4.60	2.27	6.14	2.59
<i>os nos</i>	1.71	1.33	5.28	2.60	5.90	2.64	5.46	2.56
<i>os me</i>	1.25	1.03	5.25	2.67	5.38	2.819	5.11	2.56

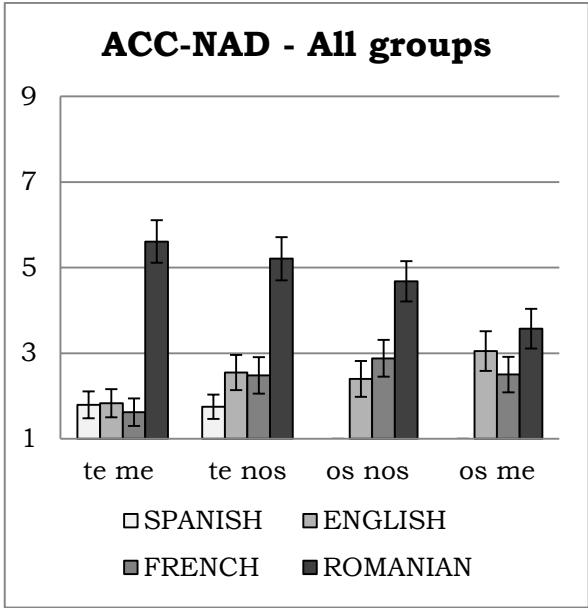

Figure 5.14. Average results for the ACC-NAD structure for all groups

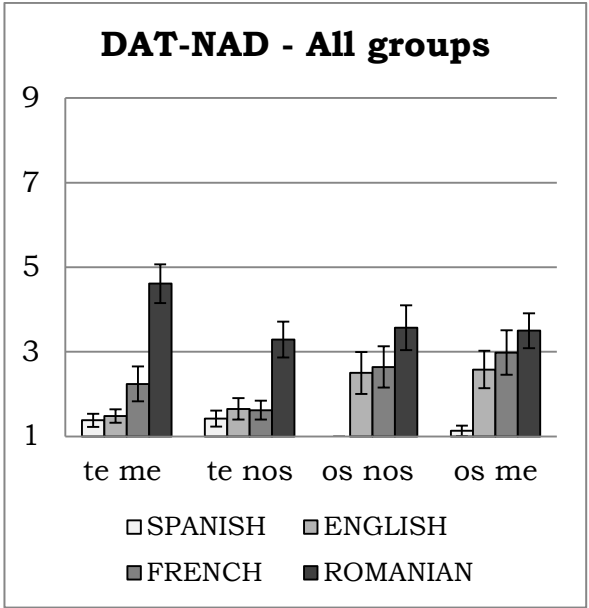

Figure 5.15. Average results for the DAT-NAD structure for all groups

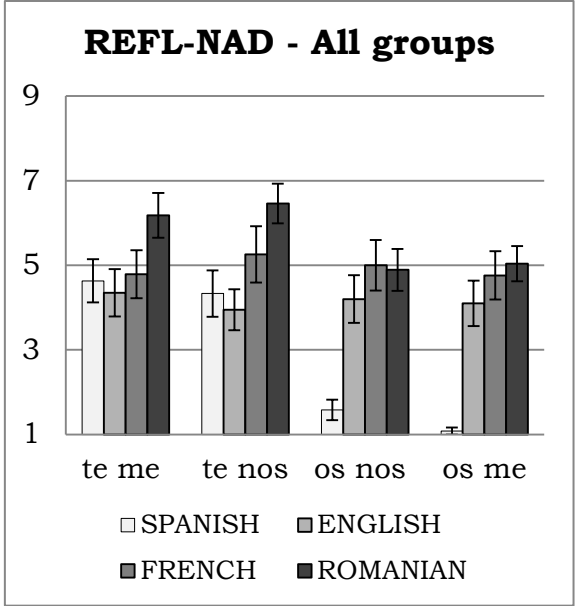

Figure 5.16. Average results for the REFL-NAD structure for all groups

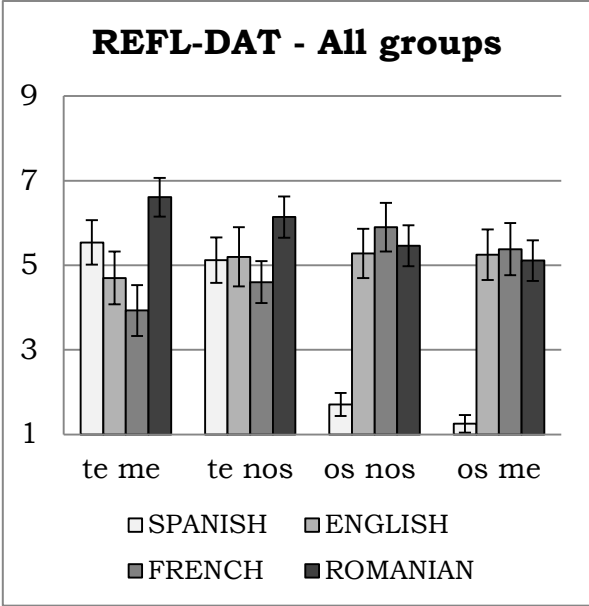

Figure 5.17. Average results for the REFL-DAT structure for all groups

As we can see in Figures 5.14 to 5.17, the Spanish group behaves differently from the L2 groups in all structure types, a difference which is particularly evident in the treatment of ungrammatical clusters in the two structures with reflexives. Also, the Romanian group assigns significantly higher scores to the grammatical conditions in all structure types. These differences between the Romanian group and the other three groups are especially apparent in the case of the structures without reflexives, where the values assigned to the ungrammatical clusters are the highest of all groups.

However, we also find similarities between the native and the non-native participants when it comes to reflexivity, since all groups provide higher ratings for the structures with a reflexive. In the case of the Spanish group, this only applies to the grammatical structures, which sets it apart from the other groups. Nevertheless, this clear-cut difference in the treatment of clusters with and without reflexives shows that reflexivity is a relevant factor for all groups. Thus, I now present the results from all groups grouped into reflexive and non-reflexive structures.

Table 5.16. Non-reflexive conditions grouped

CLUSTER	SPANISH		ENGLISH		FRENCH		ROMANIAN	
	MEAN	ST. DEV	MEAN	ST. DEV	MEAN	ST. DEV	MEAN	ST. DEV
<i>te me</i>	1.56	1.07	1.65	.978	1.98	1.47	5.11	2.23
<i>te nos</i>	1.46	.966	2.10	1.14	2.00	1.17	4.25	2.15
<i>os nos</i>	1.00	.000	2.45	1.81	2.88	2.40	4.13	2.35
<i>os me</i>	1.06	.306	2.81	1.39	2.65	1.64	3.53	2.06

Table 5.17. Reflexive conditions grouped

CLUSTER	SPANISH		ENGLISH		FRENCH		ROMANIAN	
	MEAN	ST. DEV	MEAN	ST. DEV	MEAN	ST. DEV	MEAN	ST. DEV
<i>te me</i>	5.06	2.36	4.52	1.88	4.35	2.29	6.42	2.12
<i>te nos</i>	4.58	2.43	4.54	2.17	4.95	2.18	6.22	2.12
<i>os nos</i>	1.65	1.04	4.69	2.19	5.38	2.14	5.07	2.23
<i>os me</i>	1.17	.545	4.73	1.74	5.08	2.21	5.05	1.95

Tables 5.16 and 5.17, above, provide the mean and standard deviation values for both the non-reflexive and the reflexive types and Figures 5.18 and 5.19, below, show the results according to the data reported in Tables 5.16 and 5.17, respectively.

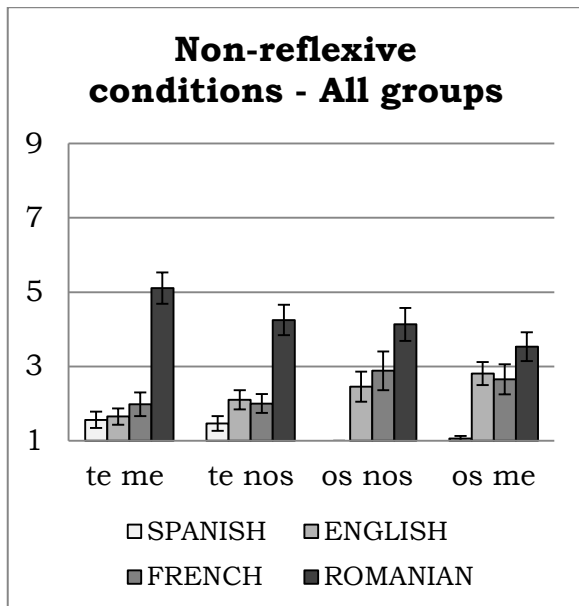

Figure 5.18. Average results for the non-reflexive conditions for all groups

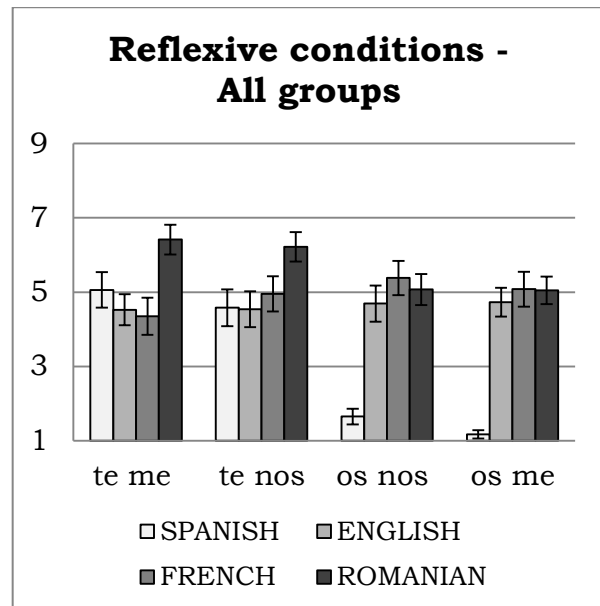

Figure 5.19. Average results for the reflexive conditions for all groups

As in the case of the previous statistical analysis, the results of a 3-way mixed ANOVA with cluster type and reflexivity as the within-subjects factors and

group (L1) as the between-subjects factor reveal a main effect for Reflexivity ($F(1,89)=201.217$, $p<.001$), as well as for Cluster ($F(3,267)=6.373$, $p<.001$) and for Group ($F(3,89)=21.424$, $p<.001$). All the interactions between the three factors are also significant.

With respect to Cluster, pairwise comparisons reveal significant differences between *te me* and *os me* ($p=.005$) as well as between *te nos* and *os me* ($p=.011$). With respect to Group, pairwise comparisons reveal significant differences between the native group and all the L2 groups ($p=.009$ for L1English, $p=.001$ for L1French and $p<.001$ for L1Romanian). In addition, the differences between Romanian and the other two L2 groups were also significant ($p<.001$ for English and $p=.006$ for French). The differences between L1 English and L1 French, however, were not significant ($p=1.000$).

5.1.5. Conclusions from the grammaticality judgment task

As shown in previous sections, all L2 groups differ from the Spanish group in terms of the overall acceptance of 1st and 2nd person clitic clusters. Specifically, the L2 groups accept ungrammatical clusters significantly more than the L1 group. The English and French groups display a similar pattern that strongly diverges from the native speakers in that the ungrammatical clusters are given higher ratings than the grammatical ones. Furthermore, in the case of the French group, the differences between clusters were significant. The Romanian group, however, departs from other L2 groups in that it assigns higher ratings to the grammatical clusters. Nevertheless, it is true that the ungrammatical ratings provided by the Romanian group are indeed rather high and that there is a considerable amount of

variability in the responses. These results pose a challenge to the view of the FMC as a universal constraint. However, given the rating distribution in all L2 groups and besides the fact that the question of the universality of the FMC remains open, it is worth noting that the high ungrammatical ratings, as compared to those provided by the Spanish group, are probably not due to high acceptance of these clusters but rather to variability and uncertainty in the judgment. Under this assumption, it may be this uncertainty that leads the participants to judge the same cluster as acceptable in some cases and as unacceptable in others, which gives an average rating that is close to the neutral value.

This apparent acceptability of ungrammatical clusters by the L2 groups contrasts with the predictions of the FMC and the NPBE. In fact, it seems to point toward the idea that the restriction has not been acquired by these speakers, with the exception perhaps of the Romanian group, who does show a preference for grammatical clusters despite the high ratings assigned to ungrammatical clusters.

A possible external influencing factor for the higher acceptance of ungrammatical clusters may be related to classroom instruction. The two ungrammatical clusters contain *os* and, even though the use of *vosotros/os* and the corresponding verbal forms are only productive in Peninsular Spanish, all students are taught this person and form and they are regularly tested on it. As a result, it is possible that learners tend to categorize *vosotros/os* as a “formal” pronoun, so seeing it on a written task may have biased them to assign higher scores to the items that contained *os*.

In general, the differences between the three L2 groups in the treatment of 1st and 2nd person clusters do not seem to be attributed to competence, or at least

not exclusively. In the case of French and Romanian the cloze test score averages are quite similar (16.71 and 16.46, respectively) and, yet, their behaviour is very different. Furthermore, the highest-scoring group (French) and the lowest-scoring group (English, with 13.95) show very similar patterns. However, it is interesting to note that the results of a regression analysis indicated that, in the case of French, higher proficiency was correlated with lower ratings for the ungrammatical clusters.

Both French and Romanian are Romance languages with object clitics like Spanish and, yet, the three groups behave very differently from one another. On the one hand, French patterns with English, which does not have clitics. On the other hand, Romanian shows much higher overall ratings than any of the other groups. However, despite the differences in the actual rating values, which are statistically significant, both the Spanish and the Romanian groups display a pattern of higher acceptance of grammatical clusters. Crucially, Romanian is the only one of the three languages that has the same version of the FMC (i.e. the PBE). In view of all this we can conclude that the effects observed in these results are quite possibly due to the effect of the L1 on the L2.

With respect to structure type, we have seen that clusters with and without reflexives are treated differently and that all groups tend to give higher ratings to clusters containing a reflexive. In fact, it is interesting to note that the reflexive vs. non-reflexive distinction was significant in all groups, despite the radical differences with respect to the acceptance of singular and plural clusters. These results indicate that all groups, both native and non-native, are sensitive to structure type and that all of them prefer clusters with a reflexive.

To conclude, I provide answers to the three research questions proposed in section 5.1.1. The first research question was: *Are clitic restrictions, particularly the ones derived from the FMC, learnable? Can such restrictions be grasped by non-native speakers?* In view of the results, we may argue that Spanish clitic cluster restrictions have not yet been acquired by the L1 English and the L1 French group. The results are not so clear-cut for the L1 Romanian group, since this group patterns with the native control, but the differences are significant for all clusters, as the Romanian participants systematically assigned higher ratings to both the grammatical and the ungrammatical clusters.

The second research question was: *Will the judgments of 1st and 2nd person clitic combinations by L2 speakers of Spanish coincide with those provided by native speakers? Specifically, will non-native speakers reject all clusters in which the non-dative outranks the dative, as predicted by the FMC? Will non-native speakers reject two plural 1st-2nd clitic clusters, as predicted by the NPBE, a language-specific restriction? And, finally, given the results reported in Chapter 4, will non-native speakers show higher acceptance rates in the case of clusters that contain a reflexive?* With respect to structure type, all groups show similarities in that they all showed significantly more acceptance for structure containing a reflexive. This implies that both the native and the non-native speakers are sensitive to the structure type of the cluster. However, the native group and the L2 groups differed significantly in the treatment of the different types of cluster. Specifically, whereas the Spanish group showed a very strong tendency to reject all ungrammatical clusters, the three L2 groups assigned significantly higher scores to these clusters than the native group.

Finally, the third research question was: *Will non-native speakers transfer the specific clitic restrictions of their L1 onto their L2? To what extent will the L1 influence their perception of L2 clitic combinations?* The results of the GJ indicate that the L1 seems to influence the acceptance and rejection patterns of clitic combinations in the L2, but only partially and only in the pair of languages that share the same restrictions. On the one hand, French speakers do not seem to resort to their L1, since they accept clusters that are not allowed in their L1. Furthermore, both French and English behave similarly despite the fact that the pronominal systems of the two L1s are very different. On the other hand, Romanian has the same restriction as Spanish and, indeed, the Romanian group patterns with the Spanish group. However, the Romanian group's acceptance ratio for each cluster is much higher than that of the Spanish group and the differences are significant. In this respect, it is worth noting that, although the data from the two experiments are not directly comparable, the native Romanian results from Nevins and Săvescu's (2010) study were also relatively high in comparison with native Spanish results.

5.2. ON-LINE SELF-PACED READING TASK

As discussed in Chapters 1 and 4, a striking fact about a sentence like (5b) is that it is ungrammatical despite being grammatically well-formed from a derivational point of view.

- (5) a) Tú **te** **me** pusiste enfermo
 You 2.PL.REFL 1.PL.DAT put sick
 'You (pl) got sick (on me)'

- b) *Vosotros **os me** pusisteis enfermos
 You.Pl 2.PL.REFL 1.PL.DAT put sick
 'You (pl) got sick (on me)'
- c) *Vosotros **te nos** pusisteis enfermos
 You.Pl 2.SG.REFL 1.PL.DAT put sick
 'You (pl) got sick (on us)'

As we have seen, the ungrammaticality of (5b) is due to a violation of the NPBE. In turn, the ungrammaticality of (5c) is due to an agreement mismatch between the reflexive pronoun and its referent. Chapter 4 (section 4.2.) explored the processing differences between these two different types of ungrammaticality. The results of an on-line-self-paced reading task distributed to native speakers of Spanish revealed that the two ungrammaticalities were indeed processed differently and that the NPBE violation, as in (5b), was more costly to the parser than the “syntactic” violation, as in (5c).

In view of the results of the native speakers, the experiment presented in the following sections explored whether non-native speakers are also sensitive to different types of ungrammaticalities.

5.2.1. Research Questions

This experiment aims to answer three research questions. First, will non-native speakers show processing differences between grammatical and ungrammatical clusters? Will the two different types of ungrammaticality (i.e. agreement mismatch vs. NPBE violations) yield different reading times? Second,

will there be processing differences between native and non-native speakers with respect to the two types of ungrammaticality? Third, will the speakers' L1 have an influence in the way structures with clitic clusters are processed?

5.2.2. Hypotheses

The native group showed significantly longer RTs in the case of the *NPBE condition, which indicated that the parser is very sensitive to NPBE violations. This was also confirmed with the GJ results. However, the results of the GJ task from the non-native groups did not show the same clear-cut rejection of the two *NPBE clusters (*os nos* and *os me*). In the case of the English and the French groups, the ratings for the *NPBE clusters were even higher than for the grammatical ones. Thus, it is unclear whether an effect will be found for the *NPBE condition, with the exception, perhaps, of the Romanian group, who showed significantly more acceptance of grammatical clusters, despite the high overall ratings.

With respect to the two types of ungrammaticality, participants are expected to be aware of the “purely syntactic” violation produced by an agreement mismatch between the reflexive and its antecedent. This was also expected for the native group. However, no effect was found for the *Syntactic condition. In spite of this, and given the fact that language processing in the L2 is more costly than in the L1, L2 participants are expected to show an increase in RTs, at least, in the *Syntactic condition.

5.2.3. *Experimental design, materials and procedure*

The same self-paced reading task was distributed to both native and non-native speakers of Spanish. Thus, the experimental design, materials and procedure were the same as described in Chapter 4 for the native speakers. A brief summary of the experimental design, materials and procedure is provided below.¹¹³

The on-line self-paced reading task contained a total of 72 items, of which 24 were experimental items and 48 were fillers.

The experiment included two types of structures, namely combinations of Reflexive and Ethical Dative (REFL-NAD), as in (6a), and combinations of Reflexive and Dative (REFL-DAT), as in (6b).

- (6) a) Tú **te** **me** enfermas
 You 2.SG.REFL 1.SG.NAD get.sick
 ‘You get sick (on me)’
- b) Tú **te** **me** presentaste
 You 2.SG.REFL 1.SG.DAT introduced
 ‘You introduced yourself to me’

All the experimental items contained five conditions, which included the four clusters of the GJ task, and an additional condition which contained a syntactic ungrammaticality caused by an agreement mismatch between the cluster’s reflexive and its antecedent which, in all cases, was the subject of the main clause. A shortened version of the sample experimental set presented in (14), in Chapter 4, is reproduced here in (7).

¹¹³ The reader is referred to sections 4.2.3, 4.2.4 and 4.2.6 of Chapter 4 for a more detailed presentation of these aspects.

- (7) A) (...) *tú te me perdiste en el supermercado.*
 You 2.SG.REFL 1.SG.NAD got.lost in the supermarket
 ‘(...) you got lost (on me) in the supermarket’
- B) (...) *tú te nos perdiste en el supermercado.*
 You 2.SG.REFL 1.PL.NAD got.lost in the supermarket
 ‘(...) you got lost (on us) in the supermarket’
- C) (...) *vosotros os nos perdisteis en el supermercado.*
 You.PL 2.PL.REFL 1.PL.NAD got.lost in the supermarket
 ‘(...) you got lost (on us) in the supermarket’
- D) (...) *vosotros os me perdisteis en el supermercado.*
 You.PL 2.PL.REFL 1.SG.NAD got.lost in the supermarket
 ‘(...) you got lost (on me) in the supermarket’
- E) **(...) vosotros te nos perdisteis en el supermercado.*
 You.PL 2.SG.REFL 1.PL.NAD got.lost in the supermarket
 ‘(...) you got lost (on us) in the supermarket’

As discussed in chapter 4, these five conditions can be grouped into three conditions, namely Grammatical (i.e. conditions including clusters *te me* and *te nos*), *NPBE (i.e. conditions including clusters *os nos* and *os me*), and *Syntactic, which corresponds to the “purely syntactic” ungrammaticality (i.e. conditions including a mismatch between the reflexive and its antecedent). The experiment also contained 3 practice trials at the beginning in order to help the participants get used to the characteristics of the experiment.

For this experiment, a word-by-word self-paced reading technique using a moving windows display was used. The materials were presented using Linger (Doug Rohde, MIT) on a 14" PC ASUS laptop computer.

Participants were asked to read carefully a number of sentences on a computer screen and answer a yes/no question that followed each sentence. At the beginning of each trial, the sentence was masked by a string of dashes. A new word of the sentence appeared every time the participant pressed the space bar. All words appeared following the linear order of the sentence and the visible word disappeared when the following word appeared. Every word in a sentence formed a region and reaction times were measured for every region. Accuracy was controlled through the yes/no questions presented after each trial. The complete experiment, including both the pre-test and the on-line self-paced reading task, took between 50 to 70 minutes to complete.

5.2.4. Results and discussion

As in the GJ task, all participants were adult speakers with an advanced level of proficiency in Spanish. They had all learned the language in an institutional setting and were living in a non-Spanish speaking country at the time of testing. All participants had normal or corrected-to-normal vision.¹¹⁴

Statistical analyses were performed on the data both collapsed into three conditions (grammatical, *NPBE and *Syntactic) and divided into five conditions (one for each individual cluster: *te me*, *te nos*, *os nos*, *os me* and **te nos*). Overall, the results of the two analyses yielded minimal differences in all L2 groups and,

¹¹⁴ The requirement to have participants with normal or corrected to normal vision was due to the fact that the stimuli were presented visually.

thus, in order to avoid excessive redundancy in the presentation of the results, only the 3-condition analyses are reported in the following subsections. Whenever there is a discrepancy between the 3-condition and the 5-condition analysis, the results of the 5-condition analysis are also reported and discussed. The graphs and complete statistical analysis for the 5-condition results are available in Appendix C.

In all cases, statistical analyses were performed on regions 14 to 17, which corresponded to the two clitics (regions 14 and 15) and the words that immediately followed the cluster, which correspond to the critical regions where effects are expected to appear (regions 16 and 17). Later regions were not analyzed in order to avoid end-of-sentence wrap-up effects that may confound an actual cluster or structure effect.

5.2.4.1. L1 English

Participants

27 persons volunteered to participate. The data from six participants had to be rejected because their L1 was not English, thus leaving a total number of 21 participants for the English group. All 21 participants were native speakers of English and six of them only spoke English and Spanish. Other languages that the participants spoke included: French (13), Farsi (2), German (1), Hebrew (1), Norwegian (1) and Portuguese (1). All the participants confirmed that their dominant language was English, which was also the language they used most regularly and the one with which they were most comfortable at the time of testing.

The participants were recruited at the University of Ottawa, Canada, (N=14) and Instituto Cervantes in London, England (N=7).

The mean age for the group was 29.55, with ages ranging between 19 and 69. The mean score for the cloze test was 14.11 out of 20 and there were 12 female and 9 male participants. None of the participants of the on-line task had participated in the GJ task.

Results

Out of the 21 participants, two of them answered correctly less than 70% of the comprehension questions that followed the target items, so their data had to be discarded. In addition, all data points under 100ms and over 3000ms were discarded, resulting in a total loss of less than 0.5% of the remaining data.

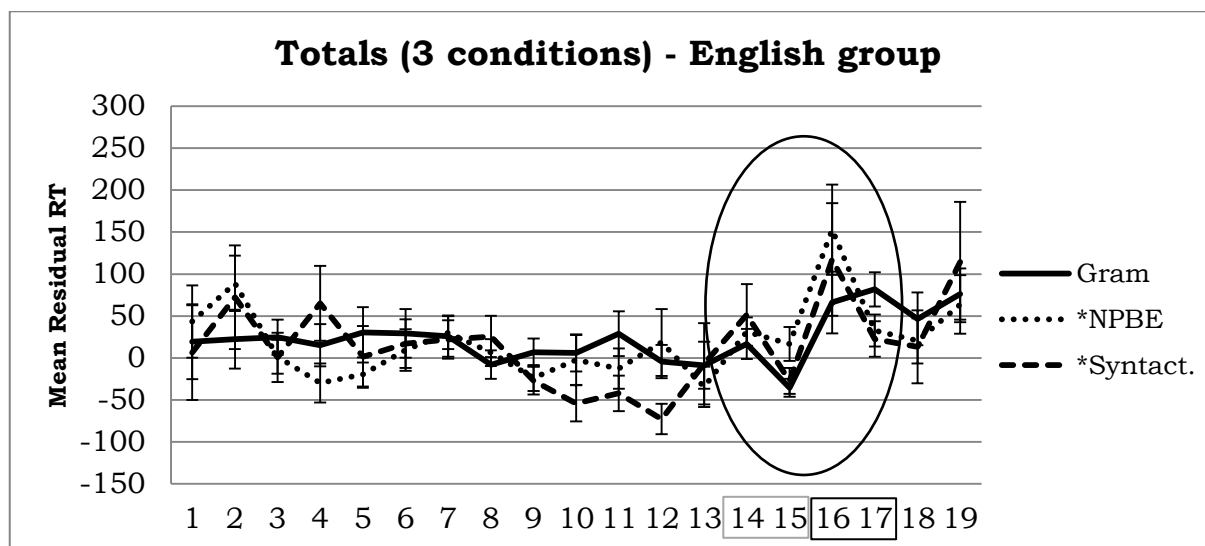

Figure 5.20. Totals grouped (3 conditions), English group

Figure 5.20, above, shows the overall grouped results of the online task. In the figure, we can see that all three conditions display longer RTs in region 16, which immediately follows the cluster (regions 14 and 15).

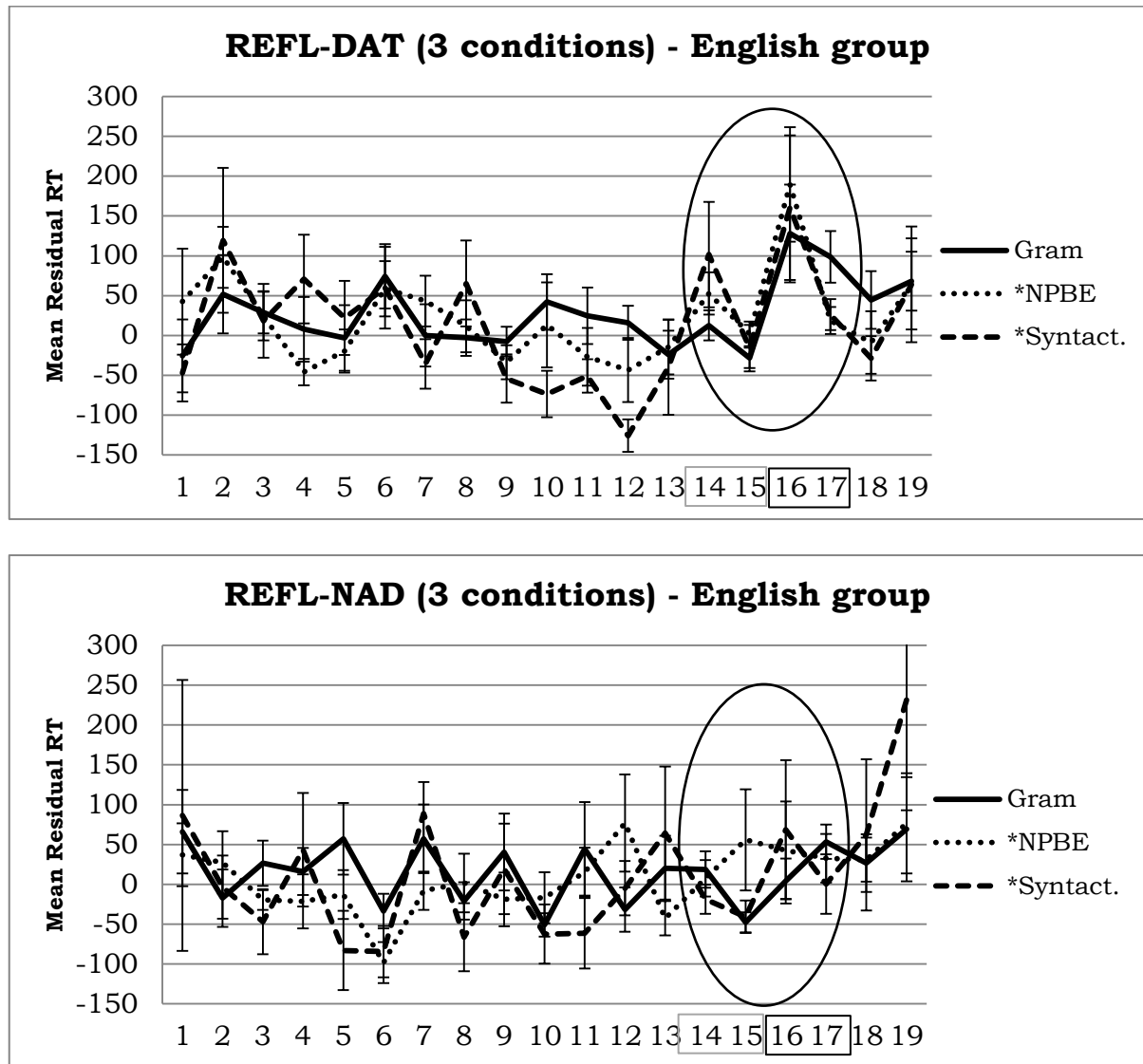

Figure 5.21. REFL-DAT and REFL-NAD grouped (3 conditions), English group

When we consider the data from each structure, as shown in Figure 5.21, we see that this pattern is also apparent in the case of the REFL-DAT structure. In

the case of the REFL-NAD, however, the RT differences in the critical regions are not as pronounced.

The results of a 2x3 repeated measures ANOVA for each critical region with Structure (REFL-DAT, REFL-NAD) and Cluster (Grammatical, *NPBE, *Syntactic) as the within-subject factors reveals no main effect for either Structure or Cluster and there was no significant interaction between the two factors for any of the critical regions ($p > .05$ in all cases).¹¹⁵ So, despite the apparent differences between the two structures, the differences between the two are not statistically significant.

With respect to cluster type, the two ungrammatical conditions display the longest RTs in the critical regions. Furthermore, and contrary to expected, the grammatical condition also displays longer RTs in the regions that immediately follow the cluster. According to the results of the ANOVA, the differences between the three conditions are not significant, which means that the participants from the English group treated all three conditions similarly. Rather than showing differentiated effects, the longer RTs seem to indicate a general difficulty in the processing of clitic clusters in their L2, regardless of whether the combination of clusters is grammatical or not.

5.2.4.2. L1 French

Participants

25 persons volunteered to participate. However, two participants had to be rejected because their L1 was not French, which left a total number of 23 participants for the French group. The 23 remaining participants were native

¹¹⁵ As in previous analyses, only the F - and p -values that correspond to statistically significant differences are reported in this section.

speakers of French and all of them reported having knowledge of English. Other languages that the participants spoke included: German (3), Arabic (2), Russian (2), Catalan (1), Farsi (1), Hebrew (1), Italian (1), Serbo-Croatian (1) and Turkish (1). All the participants confirmed that their dominant language was French, which was also the language they used most regularly and the one with which they were most comfortable at the time of testing.

The participants were recruited at the University of Ottawa, Canada, (N=3) and Instituto Cervantes in Paris, France (N=20). The mean age for the group was 51.04, with ages ranging between 19 and 78.

The mean score for the cloze test was 17.21 out of 20 and there were 19 female and 4 male participants. None of the participants of the on-line task had participated in the GJ task.

Results

Out of the 23 participants, two of them answered correctly less than 70% of the comprehension questions that followed the target items, so their data had to be discarded. In addition, all data points under 100ms and over 3000ms were discarded, resulting in a total loss of approximately 0.8% of the remaining data. Figure 5.22, below, shows the overall grouped results of the online task.

As in the case of the English group, we have longer RTs in the regions that immediately follow the cluster. However, in contrast with the English group, the ungrammatical clusters display longer RTs than the grammatical ones, a pattern that is reproduced both in the REFL-DAT structure and in the REFL-NAD structure.

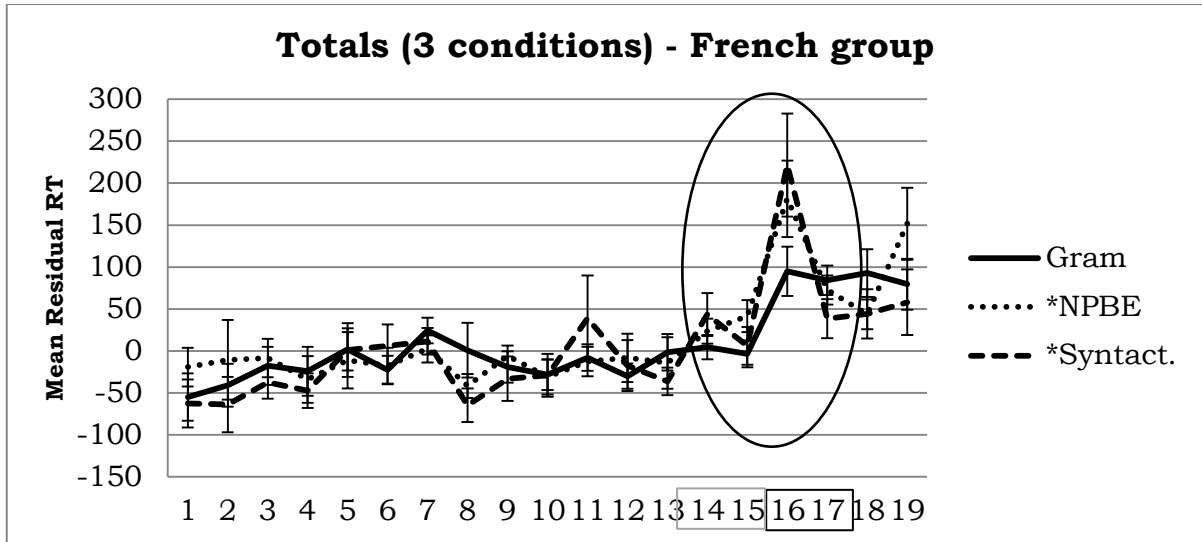

Figure 5.22. Totals grouped (3 conditions), French group

The results of a 2x3 repeated measures ANOVA for each critical region with Structure (REFL-DAT, REFL-NAD) and Cluster (Grammatical, *NPBE, *Syntactic) as the within-subject factors reveal no main effects for either Structure or Cluster for regions 14, 15 and 17. In addition, there were no significant interactions between the two factors for any of the critical regions (14 through 17). For region 16, the ANOVA reveals a main effect for Structure ($F(1,20)=8.004$ $p=.010$) and for Cluster ($F(2,40)=4.598$ $p=.016$). Pairwise comparisons using the Bonferroni correction reveal significant differences between the Grammatical and *Syntactic clusters ($p=.045$).

As we can see in Figure 5.23, the *Syntactic condition shows the longest RTs in both structure types. All three conditions display a marked increase in RTs at region 16 In the REFL-DAT structure. With respect to the REFL-NAD, the Grammatical and *NPBE conditions do not show such a marked spike, in contrast with the *Syntactic condition. Also in the REFL-NAD structure, we have an

increase in the RTs of the *NPBE condition in region 19. However, it is unclear whether this may be related to the processing of this particular condition or whether it is due to end of sentence wrap-up effects.

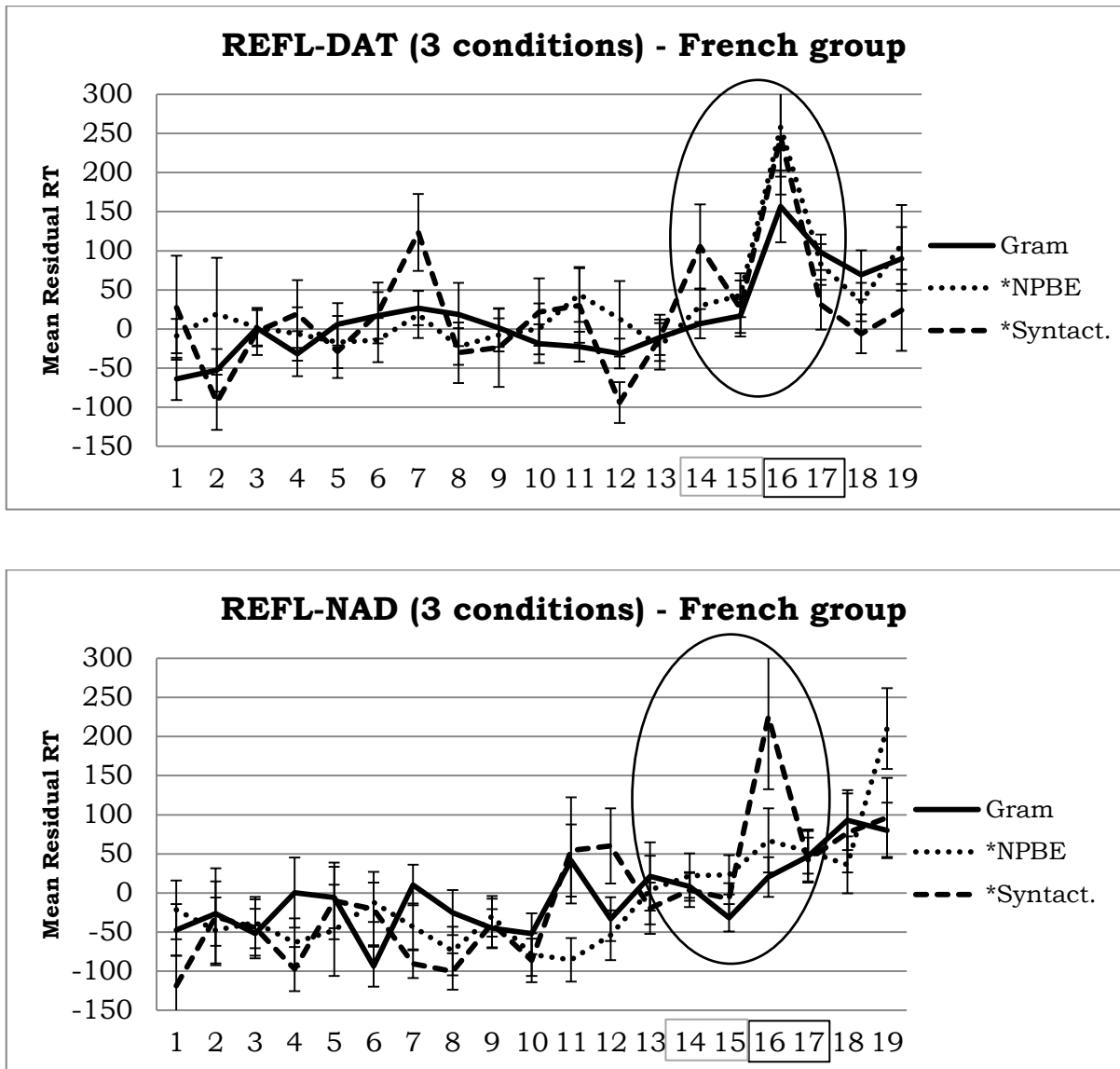

Figure 5.23. REFL-DAT and REFL-NAD grouped (3 conditions), French group

Finally, for region 17, the 5-condition analysis reveals a main effect for structure type ($F(1,19)=13.105$, $p=.002$), which reflects the fact that, whereas all clusters converge at around 50ms in the case of the REFL-DAT structure, they remain dispersed for REFL-NAD.

5.2.4.3. L1 Romanian

Participants

22 persons volunteered to participate. All 22 participants were native speakers of Romanian and all of them reported having knowledge of English. Other languages that the participants spoke included: French (12), Portuguese (2), Russian (2), German (1), Catalan (1), Italian (1) and Galician (1). All the participants confirmed that their dominant language was Romanian, which was also the language they used most regularly and the one with which they were most comfortable at the time of testing.

The participants were recruited at the University of Bucharest (N=8) and University Spiru Haret (N=14), both in Bucharest, Romania.

The mean age for the group was 24.04, with ages ranging from 21 to 34. The mean score for the cloze test was 15.14 out of 20 and there were 21 female participants and 1 male participant. None of the participants of the on-line task had participated in the GJ task.

Results

All 22 participants had at least 70% accuracy on the comprehension questions for the target items, so the data from all participants were retained for

analysis. As in the case of the other groups, all data points under 100ms and over 3000ms were discarded, resulting in a total loss of approximately 2.8% of the total data.

Figure 5.24 shows the overall grouped results of the online task and Figure 5.25 displays the results for each structure type.

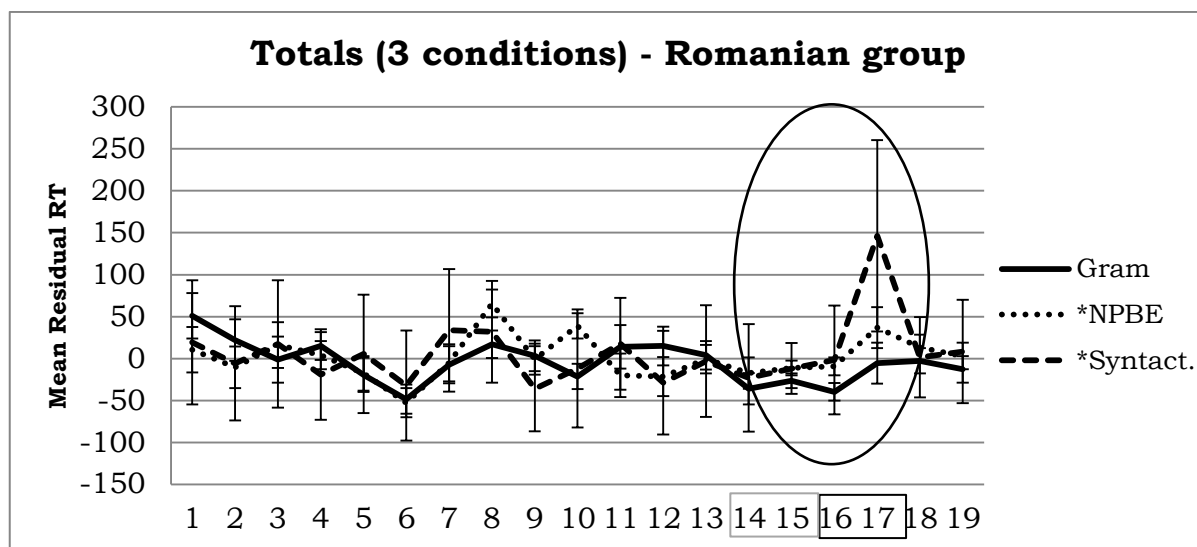

Figure 5.24. Totals grouped (3 conditions), Romanian group

The longest RTs, as in the case of the English and the French groups, correspond to the regions immediately following the cluster. The condition with the longest RTs, both overall and in each of the two structure types, is the *Syntactic one, which was also the case for the French group. The peak in RTs, however, does not occur at region 16 but at region 17. This delay in the effect is apparent in both structure types and it contrasts with both the native control and the two previous non-native groups, whose longest RTs appeared at region 16.

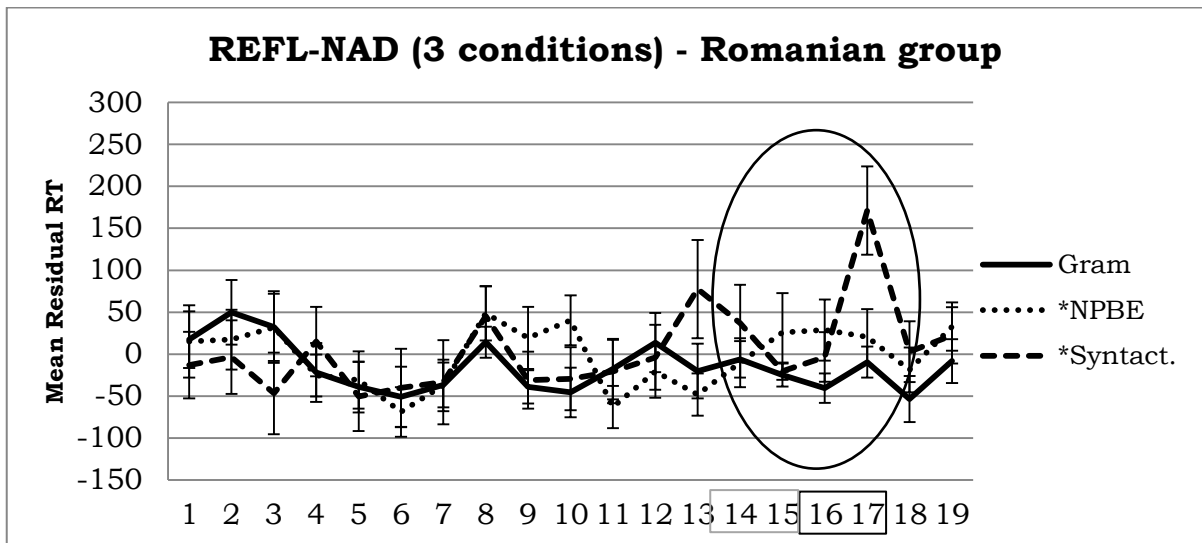
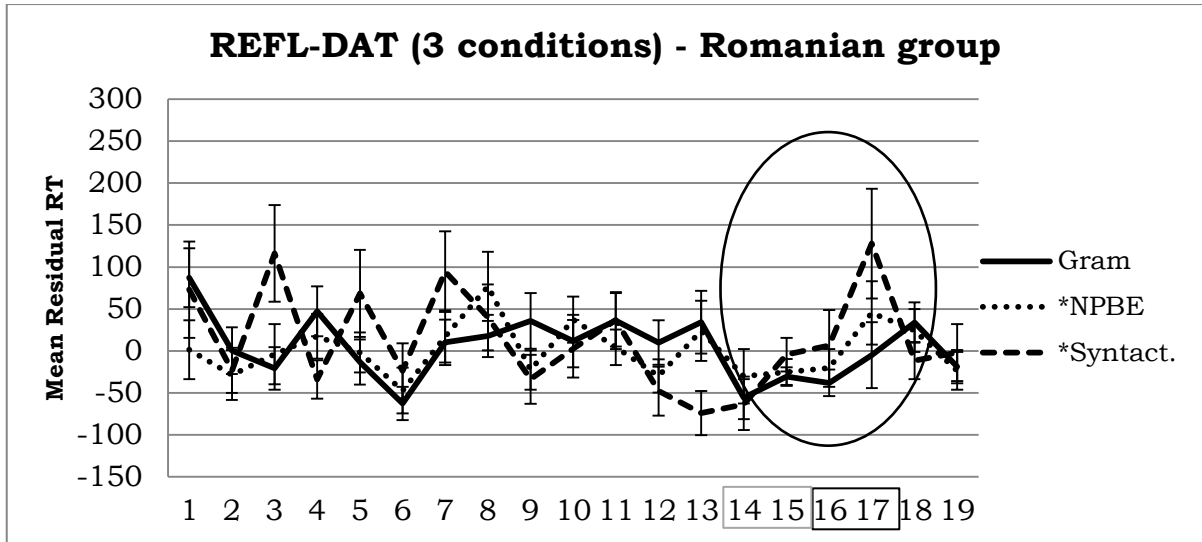

Figure 5.25. REFL-DAT and REFL-NAD grouped (3 conditions), Romanian group

For region 17, the ANOVA reveals a main effect for Cluster ($F(2,42)=7.636$ $p=.001$). Pairwise comparisons using the Bonferroni correction reveal significant differences between the Grammatical and the *Syntactic conditions ($p=.006$) and near-significant differences between the *NPBE and *Syntactic conditions ($p=.053$).

5.2.4.4. Comparison between native and non-native data

This section compares the results of the three non-native groups and the native control, whose results were presented in Chapter 4 (section 4.2). Table 5.18 provides a summary of the participants' information for each group.

Table 5.18. On-line task participant information – All groups

Group (L1)	Participants	Mean age	Mean cloze test score	Females, Males
Spanish	23	27.22	N/A	16,7
English	21	29.55	14.11	12,9
French	23	51.04	17.21	19,4
Romanian	22	23.14	15.14	21, 1

As in the previous sections, only the 3-condition analysis is reported, except when the two analyses differ, in which case, both results are reported and discussed. Figure 5.26, below, provides the overall results for all four groups. For clarity purposes, each cluster type is presented separately.

As we can see, all groups display longer RTs at the critical regions for the *NPBE condition. In addition, the Spanish group did not show a marked increase in the RTs of the Grammatical or the *Syntactic conditions, which contrasts with the non-native groups. Both the English and the French groups display an increase of RTs in all three conditions and the Romanian group also shows an increase in the RTs for the *Syntactic condition, even though the effect seems to be delayed with respect to the other groups, as it appears at region 17.

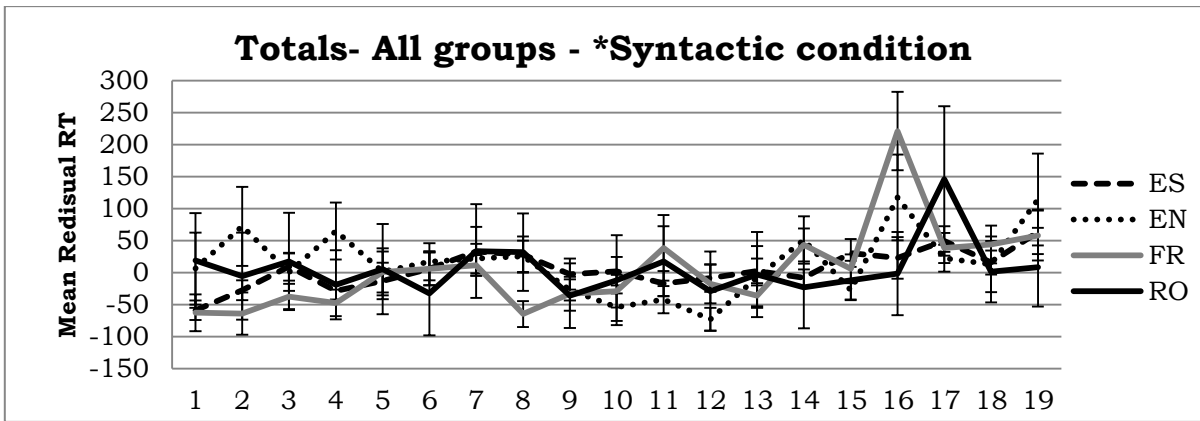
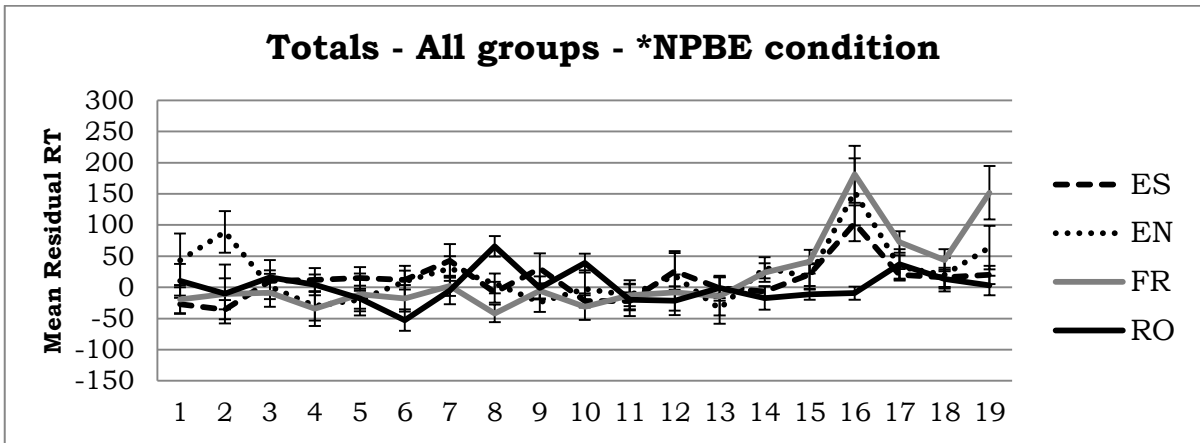
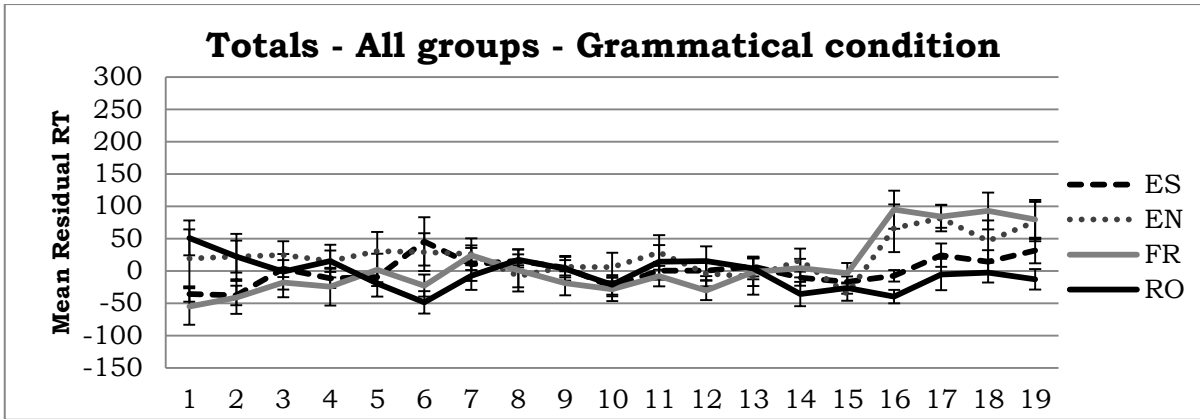

Figure 5.26. Totals all groups, Grammatical, *NPBE and *Syntactic conditions.

Figures 5.27 and 5.28 present the results of all groups by structure type. As in the case of Figure 5.26, each cluster type is presented separately for clarity purposes.

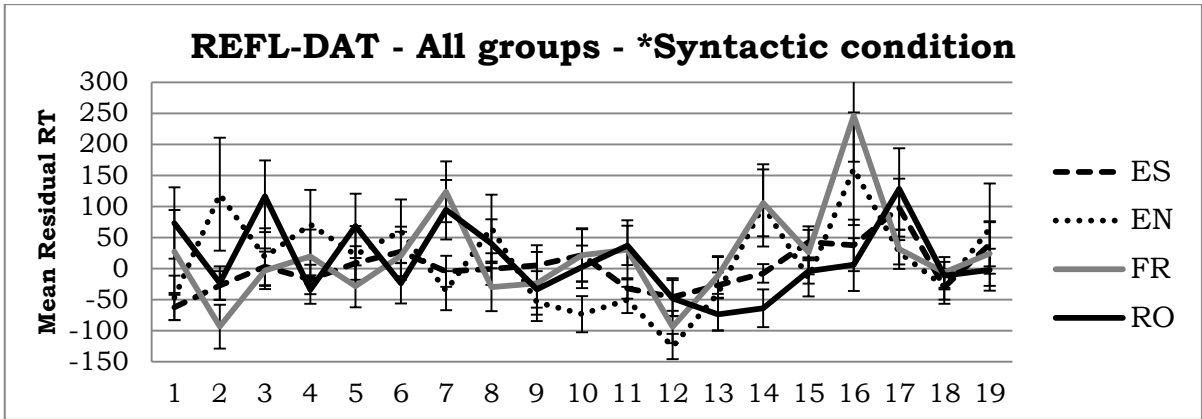
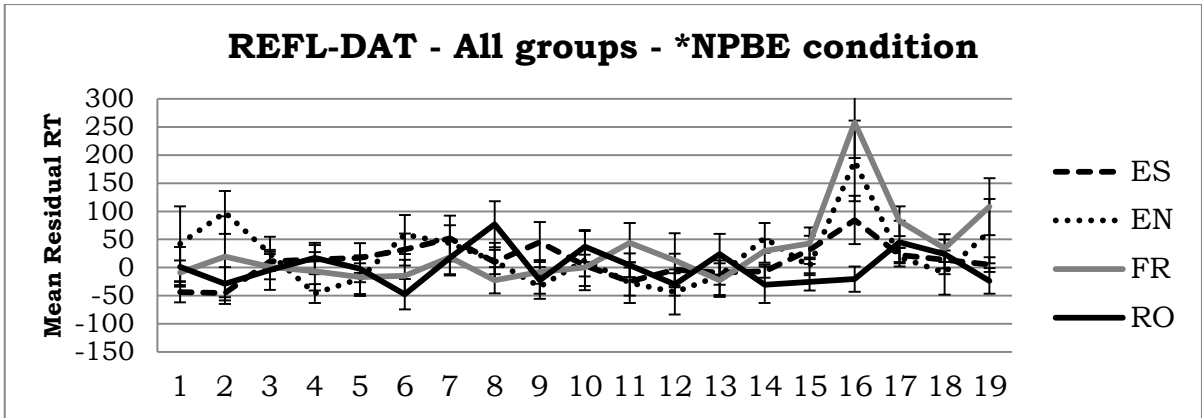
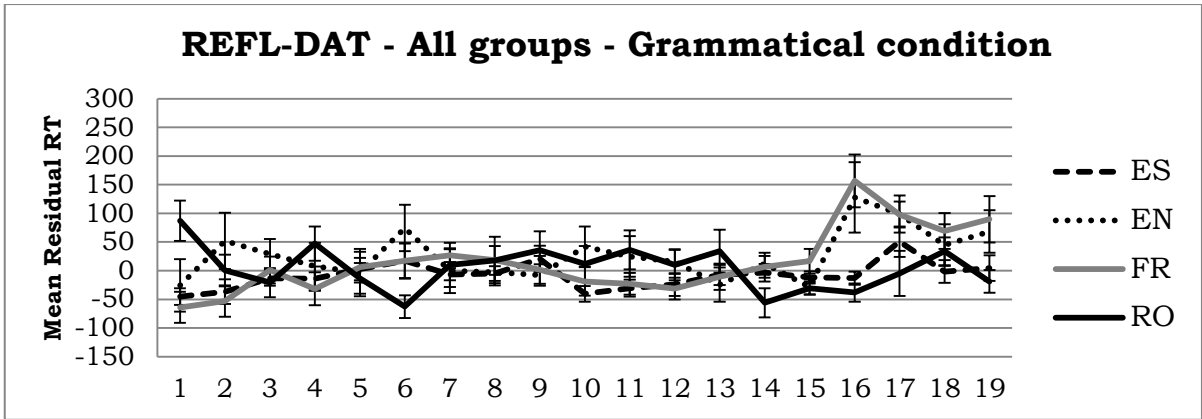

Figure 5.27. REFL-DAT structure all groups, Grammatical, *NPBE and *Syntactic conditions.

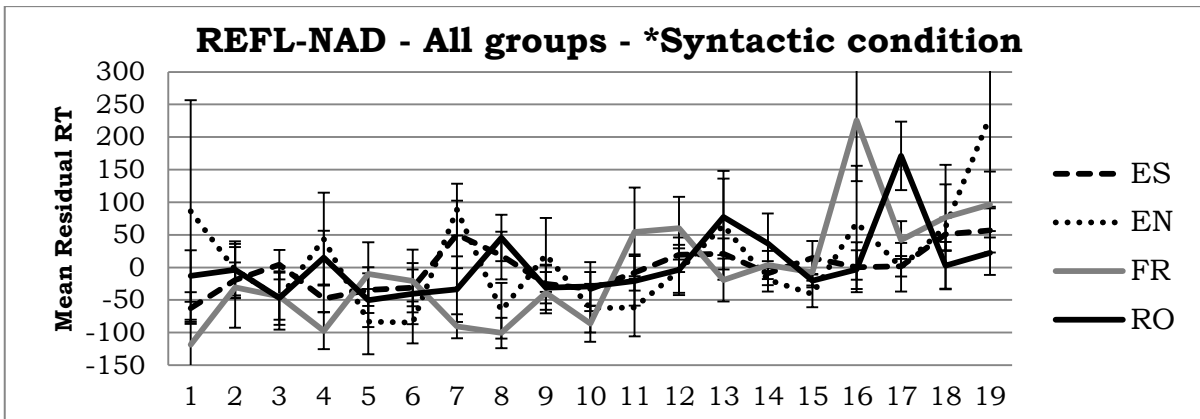
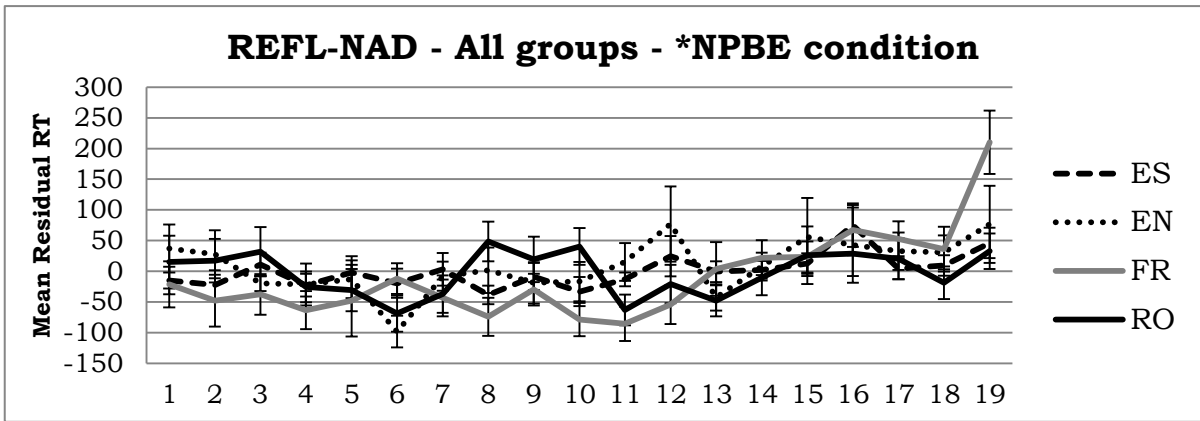
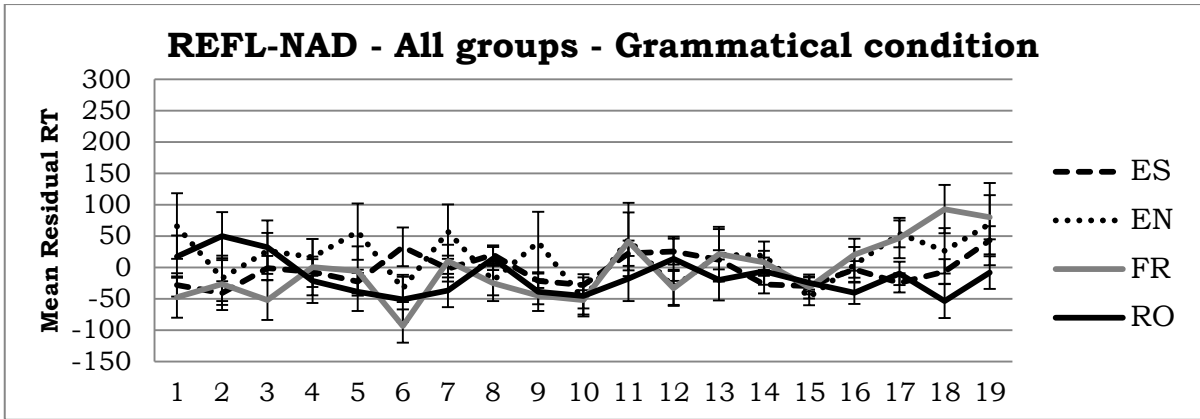

Figure 5.28. REFL-NAD structure all groups, Grammatical, *NPBE and *Syntactic conditions.

The results of a 3-way mixed ANOVA for each region with structure type (REFL-DAT, REFL-NAD) and cluster type (Grammatical, *NPBE, *Syntactic) as the

within-subject factors and group as the between-subject factor reveal significant differences for all the critical regions.

For region 14, the results of the ANOVA reveal a main effect for group ($F(3,81)=4.443$ $p=.006$). Pairwise comparisons reveal significant differences between Romanian and English ($p=.033$), as well as between Romanian and French ($p=.027$). In Figure 5.27, these differences are visible in the *Syntactic condition, where we find significantly shorter reading times for the Romanian group than for the English and the French groups. As such, the results of the ANOVA also reveal a significant interaction between the Structure and Group factors ($F(3,81)=3.872$ $p=.012$). With respect to Cluster, the 3-condition analysis reveals no main effects. There is, however, a main effect for this factor in the 5-condition analysis ($F(4,252)=2.553$, $p=.040$), but no further significant differences appear in the pairwise comparisons. Finally, the 5-condition analysis, but not the 3-condition one, reveals a significant interaction between the Structure, Cluster and Group factors ($F(12,252)=2.198$ $p=.012$).

With respect to region 15, we have a main effect for Cluster ($F(2,162)=6.295$ $p=.002$), but no main effect for Group or Structure and no significant interactions between any of the factors ($p>.05$ in all cases). Pairwise comparisons for the Cluster factor reveal significant differences between the grammatical and the *NPBE clusters ($p=.002$).

For region 16, we have a number of effects. First, we have a main effect for Group ($F(3,81)=8.002$ $p<.001$). Pairwise comparisons reveal significant differences between the Spanish and French groups ($p=.005$), between the French and the Romanian groups ($p<.001$), and between the Romanian and the English groups

($p=.037$). Indeed, as we can see in Figures 5.27 and 5.28, the French group has the longest RTs at region 16 for all conditions, except for the *NPBE condition of the REFL-NAD structure, followed by the English group. In contrast, the Romanian group has the fastest RTs at this region. The results of the ANOVA also reveal a main effect for Structure ($F(1,81)=9.717$ $p=.003$) and a significant interaction between the Structure and Group factors ($F(3,81)=3.306$ $p=.024$) (not significant in the 5-condition analysis). The ANOVA further reveals a main effect for Cluster ($F(2,162)=6.283$ $p=.002$) and pairwise comparisons reveal significant differences between the Grammatical and *NPBE conditions ($p=.001$), as well as between the Grammatical and the *Syntactic conditions ($p=.034$).

Finally, for region 17, we have a main effect for Structure ($F(1,81)=7.657$ $p=.007$) and a significant interaction between the Cluster and Group factors ($F(6,162)=4.874$ $p<.001$). There is no main effect for group, despite the longer RTs of the Romanian group for the *Syntactic condition of the REFL-NAD structure.

In sum, the results of the on-line self-paced reading task show that the native and non-native groups behave differently with respect to Cluster. First, the Spanish group shows longer RTs for the *NPBE condition and no effects for the Grammatical or the *Syntactic structures. The English and French groups show longer RTs for the *NPBE condition as well, but they also show effects for the other two conditions. In turn, the Romanian group displays the shortest RTs of all groups for the *NPBE condition. The Romanian group shares with the other L2 groups an increase in RTs for the *Syntactic condition, in contrast with the native group. However, this effect is slightly delayed and it surfaces in region 17, rather than in region 16.

The results also show a number of differences between the two structure types. In general, in all groups, the effects are more marked in the structure with an argumental dative (REFL-DAT) than in the structure with a non-argumental dative (REFL-NAD), even though the differences are not always significant within each group.

5.2.5. Conclusions from the on-line task

As we have seen in previous sections, the four groups show a number of processing differences. First, the native group showed longer RTs for the *NPBE condition, whereas the non-native groups showed longer RTs for the *Syntactic condition, even though the differences in the RTs were not statistically significant in all cases. In turn, the French and the English groups behave similarly for the most part, showing longer RTs in the critical regions for all conditions. In fact, the longest RTs for the Grammatical condition correspond to these two groups. The differences between the Grammatical and the *Syntactic conditions are significant in the case of French, but not in the case of English.

With respect to Romanian, we also find significant differences between the Grammatical and *Syntactic conditions, although the effect appears at region 17, which contrasts with the fact that all effects appear at region 16 in the other three groups.

With respect to structure type, all groups share the fact that the effects are more marked in the REFL-DAT structure than in the REFL-NAD structure.

The results show significant differences between the RTs of the three conditions, which suggests that there are indeed processing differences between

the two types of ungrammaticality. In the case of the native group, the most costly type of ungrammaticality seems to be the NPBE violation, whereas non-native speakers seem to have more difficulties processing the *Syntactic condition. This suggests that the non-native speakers are sensitive to agreement errors, but not to NPBE type violations. Furthermore, the fact that an effect was found for the grammatical condition for two of the non-native groups suggests increased processing costs for clitic clusters in general, whether they are grammatical or ungrammatical.

To conclude, I provide answers to the three research questions proposed in Section 5.2.1 as follows. The first research question was: *Will non-native speakers show processing differences between grammatical and ungrammatical clusters? Will the two different types of ungrammaticality (i.e. agreement mismatch vs. NPBE violations) yield different reading times?* In the case of the L1 English group, all three conditions showed an increase in RTs at the critical regions, but there were no significant differences between them. In other words, the results indicate an effect for all clusters, which points to general difficulties processing clitic combinations. Thus, the answer to the first research question is “no” for the English group. The French and the Romanian groups, however, did show significant differences between the Grammatical and *Syntactic conditions. In the case of Romanian, the differences between the *NPBE and *Syntactic conditions were significant. In both cases, the longest RTs corresponded to the *Syntactic condition. These differences indicate that these two groups showed processing differences between grammatical and ungrammatical clusters, so the answer to the first research question is “yes” for the French and the Romanian groups.

The second research question was: *Will there be processing differences between native and non-native speakers with respect to the two types of ungrammaticality?* As we have seen, the longest reading times belong to the *Syntactic condition in the case of French and Romanian, whereas the Spanish group displayed significantly longer RTs in the *NPBE condition and showed no effect for the *Syntactic condition. Thus, the answer to the second research question is “yes”.

Finally, the third research question was: *Will the speakers' L1 have an influence in the way structures with clitic clusters are processed?* The results of the experiment indicate that at least French and Romanian are sensitive to syntactic violations and that they trigger processing effects that are identifiable in a self-paced reading technique, since they both show significant differences between the Grammatical and the *Syntactic groups. The case of English is less clear-cut, since it treats all three conditions similarly. The fact that there are no clitic clusters in English may be a contributing factor to these results. In general, we have seen that there are clear differences between the native and the non-native groups, but also among the non-native groups. In this respect, the L1 seems to have an influence on the processing of clitic clusters in the L2. Furthermore, it is worth noting that the two groups that showed significant differences are the ones whose L1s have clitics like Spanish. This may reinforce the idea that there is influence of the L1 in the processing of the L2. However, let us recall that, in the group comparisons, the differences between Romanian and the other L2 groups were significant, but the differences between French and English were not. On the other hand, the increase in RTs for all conditions in the case of French may reflect the fact that neither of them is possible in French and, as such, the French results would also show an

effect of the L1. In sum, the results of the experiment seem to indicate L1 influence, but the data are not clear-cut enough and they do not provide sufficient information to determine the extent of L1 influence in the processing of clitic clusters in L2 Spanish.

5.3. GENERAL CONCLUSIONS FROM THE NON-NATIVE DATA

The results of the GJ task indicate that all groups, both native and non-native, seem to be sensitive to structure type, since structures with reflexives were more accepted than those without reflexives in all cases. However, in contrast with the L1 Spanish results, the L2 speakers did not reject the ungrammatical clusters across the board. In fact, in the case of L1 English and L1 French, the ungrammatical clusters received higher rates than the grammatical ones. This is most likely an indicator of uncertain ratings, rather than a preference for ungrammatical clusters. Nevertheless, the results of the GJ point to the idea that the PBE has not yet been acquired by these two groups of L2 speakers. In the case of Romanian, grammatical clusters are assigned higher scores than ungrammatical ones, which patterns with the predictions by the FMC and the NPBE. Still, the ratings of the ungrammatical clusters were much higher than expected.

In addition, the L1 seems to influence the acceptance and rejection patterns of clitic combinations in the L2. Thus, Romanian, which has the same restrictions as Spanish, patterns with the native group. However, this influence from the L1 seems to be partial—as the acceptance ratios for each cluster are much higher in the Romanian group than in the Spanish group—and it only seems to apply to the pair of languages that share the same restrictions (positive transfer). Despite the

differences in the pronominal systems of the respective L1s, the English and the French groups behave similarly and French speakers accept clusters that are not allowed in their L1.

The results of the on-line self-paced reading task show significant differences between the RTs for all groups except for English. This suggests that there are processing differences between the two types of ungrammaticality. However, in the case of the native group, we find the longest RTs in the *NPBE condition and, in the non-native groups, the longest RTs correspond to the *Syntactic condition. Thus, the parser of the native speakers proved to be very sensitive to NPBE violations, which does not seem to be the case for the L2 groups. In sum, these results suggest that the non-native speakers are sensitive to syntactic violations, such as an agreement mismatch between a reflexive and its antecedent, but not to NPBE-type violations. In addition, an effect was also found for the grammatical condition in the English and French groups, which further suggests increased processing costs for clitic clusters in general.

Finally, the differences among the non-native groups seem to indicate that there is L1 influence in the L2 processing of Spanish clitic clusters. In the case of English, the increased RTs in all three conditions may be an effect to the fact that clitic clusters do not exist in English. In the case of French, the increased RTs in all three conditions may be an effect of the fact that all conditions would be ungrammatical in French, even the grammatical one, since French rejects any combination of 1st and 2nd person clitics. In the case of the Romanian group, the influence of the L1 in the on-line task is less straightforward. The higher acceptance of both the grammatical and the ungrammatical sentences in the GJ finds a parallel in the absence of an effect in the RTs of the Grammatical and

*NPBE conditions. However, a larger effect for the *NPBE condition would be expected based on the Spanish results and on the fact that both Spanish and Romanian have the same version of the clitic restriction.

6. CONCLUSIONS AND FURTHER RESEARCH

The general goal of this dissertation was to explore the ways in which linguistic theory can account for experimental data and, conversely, the ways in which experimental data can contribute to linguistic theory. More specifically, this dissertation presented a multidimensional view of Spanish clitic restrictions that aims to contribute to a better understanding of clitic phenomena and agreement restrictions in general. As such, Spanish clitic clusters were analyzed from different perspectives, including linguistic theory, diachronic change, language processing and second language acquisition. The following subsections provide the conclusions from the different approaches to Spanish clitic clusters that were explored in this dissertation and include suggestions for further research.

Theoretical accounts

Scholars have proposed different approaches to explain the combinatorial possibilities of clitic clusters and their restrictions. Among the different proposals, we have linear ordering templates (Perlmutter 1971), morphologic accounts (Bonet 1991; Heap 1998, 2005; Rivero 2008), syntactic accounts (Anagnostopoulou 2003,

2005; Ormazabal and Romero 2007; Adger and Harbour 2007) and Optimality Theory accounts (Grimshaw 1997, 2001). As discussed in Chapters 1 and 2, a number of aspects appear as a constant in many of these studies, namely the effects of case (Bonet, 1991; Săvescu 2009; among others), the relevance of morphosyntactic features such as person (Bonet, 1991; Anagnostopoulou, 2005; Heap, 2005; among others) and the notion that clitics are organized according to a feature hierarchy that is responsible for certain ungrammaticalities associated with clitic combinations (Bonet, 1991; Bianchi 2006; Heap 2005; Săvescu 2009; among others). In line with these key points, I proposed the Feature Markedness Constraint, presented in Chapter 2 and reproduced here in (1).

- (1) A. In a combination of clitics, a dative clitic cannot be outranked in terms of marked features by a non-dative clitic.
- B. The acceptability of two clitics that contain equally marked features is language-specific.

In addition, I defended that the realization of Part B of the FMC in Spanish corresponds to the so-called Plural-Blocking Effect (Alba de la Fuente 2010), according to which “in a combination of clitics, a dative clitic cannot be outranked in terms of marked features by a non-dative clitic”.

These two restrictions were able to successfully account for the examples presented in Chapters 1 and 2. Chapters 3, 4 and 5 tested the validity of the FMC and the NPBE through different types of data.

Diachronic data

Chapter 3 presented a diachronic analysis of 1st and 2nd person clusters in Spanish based on the FMC and the NPBE. The diachronic study was performed

using data from the Diachronic Corpus of Spanish (CORDE) of the Real Academia Española. All possible combinations of 1st and 2nd clitic sequences were considered in the study and the analysis included all tokens returned by the search engine. The search covered all types of text since the earliest available texts written in Spanish, from the 11th and 12th centuries, to 1975.

A large number of the combinations analyzed corresponded to cases that were not actually subject to the FMC. In most cases, the first element was a subject pronoun or an object of a preposition. Cases of interpolation were also present in the data. Most of the cases that were subject to the FMC were compliant with the restriction, even in cases in which the linear order did not respect the rules of Modern Spanish (ModSp). There were, however, up to 9 cases that seemed to violate the FMC, all of which corresponded to the cluster *os me*.

It is particularly relevant that all these potential FMC violations appeared within a very specific timeframe, namely, in the 16th and 17th centuries. It is precisely during this timeframe that we also find combinations that do not comply with the ordering rules of ModSp and, as such, we have several examples of *me os*. Crucially, the shift from the standard Old Romance DAT-ACC to DAT-ACC has also been argued to take place in the 16th and 17th centuries. Furthermore, this timeframe corresponds to the period immediately after the change of status of the Spanish clitics, which has been argued to take place around the 15th century.

In view of this, the presence of these cases that challenge the FMC may be attributed to the fact that it seems to be an effect of these readjustments in the language.

In addition, between the 15th and 17th centuries the cluster *os me* is in competition with *me os*, which indicates that this is also a period of readjustment

of the linear ordering of clitics towards the current preference to order clitics by person, rather than by case. Along these lines, we may even consider the possibility that the offending *os me* cases may actually be instances of over-regularization of the new ordering template that requires 1st person to follow 2nd person.

In sum, a limited number of examples that challenge the FMC appear during a very specific timeframe that corresponds to a period of readjustment in the language. In contrast, most cases analyzed in the diachronic study are consistent with the FMC and demonstrate that there is a very strong tendency in Spanish to reject clitic clusters in which the non-dative outranks the dative in terms of [Number]. In this respect, the FMC works as an accurate predictor of acceptable and unacceptable combinations, both in ModSp and in previous stages of the language. In addition, the diachronic data provided relevant data on the evolution of linear ordering constraints, such as Perlmutter's order, according to which 2nd person clitics must precede 1st person and 3rd person must follow 2nd and 1st person in a cluster. Further research including 3rd person clitics would be necessary in order to have a clearer picture of the evolution of these ordering constraints.

Native versus non-native experimental data.

In order to explore the grammatical and processing status of 1st and 2nd clitic clusters in the grammars of native and non-native speakers of Spanish, two experimental tasks were distributed to different groups of speakers. The participants were one group of native speakers of Peninsular Spanish and three

groups of advanced L2 learners whose L1s were English, French and Spanish, respectively.

The first experiment consisted of a scaled grammaticality judgment (GJ) task, whose main goal was to obtain a clearer picture of speaker's perception and intuitions about 1st and 2nd person clitic restrictions. In addition, an on-line self-paced reading task was also distributed to native and non-native speakers of Spanish in order to gain insight on how these constructions are processed and to explore the possibility of clitic restrictions being linked to processing constraints.

Despite the low overall ratings provided by the native group, the results of the GJ task are robust and show a very clear tendency to reject clusters that do not comply with the FMC and the NPBE. However, the results of the L2 groups were not as clear-cut. In general, the ratings that the L2 speakers assigned to the ungrammatical clusters were much higher than expected. These results are in contrast with the predictions made by the theory and are in sharp contrast with the native results. Nevertheless, these relatively high ratings seem to be caused by uncertainty, rather than by an actual preference for ungrammatical clusters. Specifically, the non-native groups showed much more variability in their ratings of the ungrammatical clusters than the natives. Furthermore, L1 English and L1 French did not show significant differences between the grammatical and ungrammatical clusters. Only L1 Romanian shows significant differences between the two grammatical clusters (*te me* and *te nos*) and the ungrammatical cluster *os me*. Considering that both Spanish and Romanian share the same restrictions, these results seem to indicate that there is some degree of positive transfer from the L1 in the case of the Romanian group.

In addition to the different clitic combinations, the experiment included sentences with and without reflexives. Crucially, all groups were much more prone to accept a cluster if it contained a reflexive. In the case of the native group, the grammatical clusters with reflexives received much higher rates than any other cluster. This was also true for the L2 groups, which indicates that, whereas these non-native speakers do not seem to be sensitive to restrictions such as the FMC and the NPBE, they were sensitive to structure type.

With respect to the native group, we saw that there was a division between “high raters”, who assigned higher scores the grammatical clusters with reflexives, and “low raters”, who tended to assign low ratings overall. This variability in the acceptance of grammatical clitic clusters by native speakers is somewhat remnant of the variability found in the diachronic data, specifically those from the 15th and 16th centuries. However, further investigation would be required to determine to what extent these two phenomena are related. Along these lines, further research may be able to pinpoint whether this variability is indicative of a change in progress by which Spanish will go from a Weak PCC language (i.e. one that accepts combinations of 1st and 2nd person clitic combinations) to a Strong PCC language (i.e. one that bans all combinations of 1st and 2nd person clitic clusters).

The results of the on-line task also showed differences between the native and non-native groups. This task contained grammatical clusters and two types of ungrammaticality, namely NPBE violations, as in the GJ task, and syntactic violations caused by an agreement mismatch between the reflexive pronoun and its antecedent.

The native speakers displayed the longest reading times (RTs) in the case of the NPBE violation, which seems to indicate that this type of ungrammaticality is

more taxing for the parser than the syntactic violation. The non-native groups, however, showed increased RTs in the case of the *syntactic condition, although the French group and, particularly, the English group showed increased RTs in all conditions, even the grammatical one. These results show that the L2 speakers are sensitive to this type of syntactic violation and that they have difficulties processing clusters, regardless of whether they are grammatical or not.

In view of these results, two main conclusions can be drawn from the experimental data: 1) the presence of a reflexive is crucial for the acceptability of 1st and 2nd person clitic clusters and 2) FMC ungrammaticalities seem to have a different status than other types of ungrammaticality.

It is obvious from these data that the presence of a reflexive clitic in a cluster is a determining factor for its acceptance. However, the effect of reflexives and reflexivity on clitic clusters constraints had not yet been explored in depth. Thus, the results of the GJ task invite a reconsideration of theoretical accounts to include reflexivity as a determining factor of the acceptability patterns of clitic clusters and the results of the on-line task open the door to further investigation about the link between sentence processing and clitic cluster constraints.

REFERENCES

- Academia Română, Institutul de lingvistică „Iorgu Iordan - Al. Rosetti” (2005). *Gramatica limbii române I, Cuvântul*. Bucurest: Editura Academiei Române.
- Adger, D. (2003). *Core Syntax*. Oxford: Oxford University Press.
- Adger, D. and Harbour, D. (2007). Syntax and Syncretisms of the Person Case Constraint. *Syntax* 10 (1), 2-37.
- Adger, D. and Harbour, D. (2008). Why Phi? In Adger, D., Harbour, D. and Béjar, S. (eds.). *Phi Theory: Phi-Features across Domains and Interfaces* (pp.1-34). Oxford: Oxford University Press.
- Alba de la Fuente, A. (2010). More on the clitic combination puzzle: Evidence from Spanish, Catalan and Romanian. In Colina, S., Olarrea, A. and Carvalho, A. M. (eds.). *Romance Linguistics 2009. Selected papers from the 39th Linguistics Symposium on Romance Languages (LSRL), Tuscon, Arizona, March 2009* (pp. 203-215). Amsterdam: John Benjamins.
- Alba de la Fuente, A. and Dukova-Zheleva, G. (2007). Anaphor processing in Spanish or Why a policeman can fine himself. In Alba de la Fuente, A., Barajas-Garrido, G., Pérez-Tattam, R., Pifano, D. and Zúñiga-Cortés, K. (eds.). *Proceedings of the II Jornadas de Investigación de Estudios Hispánicos* (pp. 66-76). University of Ottawa.
- Albizu, P. (1997). Generalized Person-Case Constraint: A case for a syntax-driven inflectional morphology. In Uribe-Etxebarria, M. and Mendikoetxea, A. (eds.). *Theoretical issues on the morphology-syntax interface*. (pp. 1-33). Donostia: Gipuzkoako Foru Aldundia/EHU.
- Anagnostopoulou, E. (2003). *The Syntax of Ditransitives: Evidence from Clitics*. Berlin: Mouton de Gruyter.
- Anagnostopoulou, E. (2005). Strong and Weak Person Restrictions: a Feature Checking Analysis. In Heggie, L. and Ordóñez, F. (eds.). *Clitic and Affix Combinations* (pp.199-235). Amsterdam: John Benjamins.
- Anderson, S. R. (1992). *A-Morphous morphology*. Cambridge: Cambridge University Press.

- Badecker, W. and Straub, K. (2002). The Processing Role of Structural Constraints on the Interpretation of Pronouns and Anaphors. *Journal of Experimental Psychology: Learning, Memory and Cognition* 28 (4), 748-769.
- Béjar, S. and Rezac, M. (2003). Person licensing and the derivation of PCC effects. In Pérez-Leroux, A. T. and Roberge, Y. (eds.). *Romance linguistics: Theory and acquisition. Selected papers from the 32nd Linguistic Symposium on Romance Languages (LSRL), Toronto, April 2002* (pp.49-62). Amsterdam: John Benjamins.
- Bello A. (1990 [1847]). *Gramática de la lengua castellana*. Madrid: Edaf.
- Benveniste, É. (1966). *Problèmes de linguistique générale*. Paris: Gallimard.
- Bianchi, V. (2006). On the syntax of personal arguments. *Lingua* 116, 2023-2067.
- Bock, J. K. (1982). Toward a cognitive psychology of syntax: Information processing contributions to sentence formulation. *Psychological Review* 89, 1-47.
- Boeckx, C. (2001). *Mechanisms of chain formation*. PhD dissertation. University of Connecticut, Storrs.
- Bonet, E. (1991). *Morphology after Syntax: Pronominal Clitics in Romance Languages*. PhD Dissertation. MIT.
- Bonet, E. (1994). The Person-Case Constraint: A Morphological Approach. *MIT Working Papers in Linguistics* 22. *The Morphology-Syntax Connection*, 33-52.
- Bonet, E. (2008). The Person-Case Constraint and repair strategies. In D'Alessandro, R., Fischer, S. and Hrafnbjargarson, G. (eds.). *Agreement Restrictions* (pp. 103-128). Berlin: De Gruyter.
- Booij, G. (1996). Cliticization as prosodic integration. *The Linguistic Review* 13, 219-242.
- Borer, H. (1984). *Parametric Syntax: Case Studies in Semitic and Romance Languages*. Dordrecht: Foris.
- Bruhn de Garavito, J. (2006). Knowledge of clitic doubling in Spanish: Evidence against pattern learning. In *Inquiries in language development: Studies*

in honor of Lydia White (pp.305-33). Amsterdam: John Benjamins.

Bruhn de Garavito, J. and Montrul, S. (1996). Verb movement and clitic placement in French and Spanish as a second language. In Stringfellow, A., Cahana-Amitay, D., Hughes, E. and Zukowski, A. (eds.). *Proceedings of the 20th Annual Boston University Conference on Language Development* (pp.123-134). Somerville: Cascadilla Press.

Bruhn de Garavito, J., Heap, D. and Lamarche, J. (2002). French and Spanish se: underspecified, not reflexive. In S. Burrelle and S. Somesfalean (eds.). *Proceedings of the 2002 Annual Conference of the Canadian Linguistics Association* (pp.42-54). Montreal: Canadian Linguistic Association.

Camacho, V. (2005). Cambio lingüístico y los pronombres átonos. *Lengua. Revista de la Academia Nicaragüense* 30, 195-208.

Cano Aguilar, R. (ed.) (2005). *Historia de la lengua española*. Barcelona: Ariel.

Cardinaletti, A. & Starke, M. (1996). Deficient pronouns: A view from Germanic. In Thrainsson, H., Epstein, D. and Peter, S. (eds.). *Studies in Comparative Germanic Syntax, Vol. 2* (pp. 21-65). Dordrecht: Kluwer.

Cardinaletti, A. and Starke, M. (1999). The typology of structural deficiency: A case study of the three classes of pronouns. In van Riemsdijk, H. C. (ed.). *Clitics in the Languages of Europe* (pp.145-233). Berlin: Mouton de Gruyter

Chomsky, N. (1981). *Lectures on Government and Binding*. Dordrecht: Foris.

Chomsky, N. (1993). A Minimalist Program for Linguistic Theory. In Hale, K. and Keyser, S. J. (eds.). *The view from Building 20. Essays in Linguistics in Honor of Sylvain Bromberger* (pp. 1-52). Cambridge, Mass.: MIT Press.

Chomsky, N. (1995). *The minimalist program*. Cambridge, Mass.: MIT Press

Chomsky, N. (2000). Minimalist inquiries: The framework. In Martin, R., Michaels, D. and Uriagereka, J. (eds.). *Step by step: Essays on minimalist syntax in honor of Howard Lasnik* (pp. 89-156). Cambridge, Mass.: MIT Press.

Chomsky, N. (2001). Derivation by phase. In Kenstowicz, M. (ed.). *Ken Hale: A life in language* (pp. 1-52). Cambridge, Mass.: MIT Press.

- Cinque, G. (2002). *The Functional Structure of DP and IP. The Cartography of Syntactic Structures*. New York: Oxford University Press.
- Cuervo, M. C. (2002). *Spanish clitics: Three of a perfect pair*. Ms. MIT.
- Cuervo, M. C. (2003). *Datives at large*. PhD dissertation. MIT
- DeSmedt, K. (1990). *Incremental sentence generation: A Computer Model of Grammatical Encoding*. PhD dissertation. Katholieke Universiteit Nijmegen.
- Duffield, N. and White, L. (1999). Assessing L2 knowledge of Spanish clitic placement: Convergent methodologies. *Second Language Research* 15, 133–160.
- Eberenz, R. (2005). 'Cambios morfosintácticos en la Baja Edad Media'. In Cano, R. (coord.) *Historia de la lengua española* (2nd ed.) (pp. 613-656). Barcelona: Ariel.
- Epstein, S., Flynn, S. and Martohardjono, G. (1996). Second language acquisition: theoretical and experimental issues in contemporary research. *Brain and Behavioral Sciences* 19, 677-758.
- Evans, K. J., Lepschy, G. C., Morris, S. C., Newman, J. and D. Watson, D. (1978). Italian clitic clusters. *Studi italiani di linguistica teorica ed applicata* 7, 153-168.
- Fernández Soriano (1999). El pronombre personal. Formas y distribuciones. Pronombres átonos y tónicos. In Bosque, I. and Demonte, V. (Dirs.) *Gramática descriptiva de la lengua española, Vol. 1* (pp. 1209-1273). Madrid: Espasa.
- Ferreira F. and Engelhardt, P. E. (2006). Syntax and Production. In Traxler, M. and Gernsbacher, M. A. (eds.). *Handbook of Psycholinguistics* (pp. 61-91). Oxford: Elsevier.
- Ferreira, V. (1996). Is It Better to Give Than to Donate? Syntactic Flexibility in Language Production. *Journal of Memory and Language* 35, 724-755.
- Flynn, S. & Martohardjono, G. (1994). Mapping from the initial state to the final state: the separation of universal principles and language-specific principles. In B. Lust, B., Suñer, M. and Whitman, J. (eds.). *Syntactic theory and first*

language acquisition: crosslinguistic perspectives. Vol. 1: Heads, projections and learnability (pp. 319-335). Hillsdale: Lawrence Erlbaum.

Fontana, J. (1993). *Phase structure and the syntax of clitics in the history of Spanish*. PhD Dissertation. University of Pennsylvania.

Fontana, J. (1994). A variationist account of the development of the Spanish clitic system. In Beals, K. (ed.). *Papers from the 13th regional Meeting of the Chicago Linguistic Society, Vol. 2: The parasession on variation in linguistic theory* (pp. 87-100). Chicago: Chicago Linguistic Society.

Fontana, J. (1997). On the integration of second position phenomena. In Kemenade, A. and Vincent, N. (eds.). *Parameters of Morphosyntactic Change* (pp. 207-249). Cambridge: Cambridge University Press.

Franco, J. (1993). *On Object Agreement in Spanish*. Ph.D. dissertation. University of Southern California, Los Angeles.

Franco, J. (2000). Agreement as a Continuum, the Case of Spanish Pronominal Clitics. In Beukema, F. and den Dikken, M. (eds.). *Clitic Phenomena in European Languages* (pp. 147-190). Amsterdam: John Benjamins.

García, E. (2009). *The Motivated Syntax of Arbitrary Signs: cognitive constraints on Spanish clitic clustering*. Amsterdam: John Benjamins.

Gass, S. and Selinker, L. (eds.) (1994). *Language transfer in language learning*. Amsterdam: John Benjamins.

Gerlach, B. (2002). *Clitics between syntax and lexicon*. Amsterdam: John Benjamins.

Gerlach, B. and Grijzenhout, J. (eds.) (2000). *Clitics in Phonology, Morphology and Syntax*. Amsterdam: John Benjamins.

Grimshaw, J. (1997). The Best Clitic: Constraint Conflict in Morphosyntax. In Haegeman, L. (ed.). *Elements of Grammar* (pp. 169-196). Dordrecht: Kluwer.

Grimshaw, J. (2001). Optimal Clitic Position and the Lexicon in Romance Clitic Systems. In Legendre, G., Grimshaw, J. and Vikner, S. (eds.). *Optimality Theoretical Syntax* (pp.105-240). Cambridge, Mass: MIT Press.

- Guijarro-Fuentes, P. and Ortiz-López, L. (2008). Creole/Spanish contact and the acquisition of clitics on the Dominican-Haitian border. *International Journal of Bilingualism* 12 (4), 231-262.
- Hall, T. A. (1999). Phonotactics and the prosodic structure of German function words. In Hall, T. A. and Kleinhenz, U. (eds.). *Studies on the phonological word* (pp.99-131). Amsterdam: John Benjamins.
- Halle, K. (1973). Person marking in Walbiri. In Anderson, S. R. and Kiparsky, P. (eds.). *A Festschrift for Morris Hale* (pp. 308-344). New York: Holt, Rinehart and Wintson.
- Halle, M. and Marantz, A. (1993). Distributed Morphology and the Pieces of Inflection. In Hale, K. and Keyser, S. J. (eds.). *The View From Building 20* (pp.111-176). Cambridge, Mass.: MIT Press.
- Harley, H. and Ritter, E. (2002a). A feature-geometric analysis of person and number. *Language*, 78 (3), 482-526.
- Harley, H. and Ritter, E. (2002b). Structuring the bundle: A universal morphosyntactic feature geometry. In Simon, H. J. and Wiese, H. (eds.). *Pronouns: Grammar and Representation* (pp.23-39). Amsterdam: John Benjamins.
- Harley, H. and Ritter, E. (1998). *Meaning in morphology: Motivating a Feature-Geometric Analysis*. Ms. University of Calgary and University of Pennsylvania.
- Harris, J. (1995). The morphology of Spanish clitics. In Campos, H. and Kempchinsky, P. (eds.). *Evolution and revolution in linguistic theory* (pp. 168-198). Washington: Georgetown University Press.
- Haspelmath, M. (2004). Explaining the Ditransitive Person-Role Constraint: a usage-based account. *Constructions*, 2/2004. Retrieved August 20th, 2008, from <http://email.eva.mpg.de/~haspelmt/2004dpr.pdf>
- Hayes, B. (1989). The prosodic hierarchy in meter. In Kiparsky, P. and Youmans, G. (eds.). *Phonetics and Phonology, Volume 1: Rhythm and Meter* (pp. 201-260). San Diego: Academic Press.

- Heap, D. (1998). Optimizing Iberian Clitic Sequences. In Lema, J. and Treviño, E. (eds.). *Theoretical Advances in Romance Linguistics* (pp. 227-248). Amsterdam: John Benjamins.
- Heap, D. (2005). 'Constraining Optimality: Clitic sequences and Feature Geometry'. In Heggie, L. and Ordóñez, F. (eds.). *Clitic and Affix Combinations* (pp. 81-102). Amsterdam: John Benjamins.
- Holmberg, A. and Hróarsdóttir, T. (2002). Agreement and Movement in Icelandic raising constructions. *Working Papers in Scandinavian Syntax* 69, 147-168.
- Jaeggli, O. (1982). *Topics in Romance Syntax*. Dordrecht: Foris.
- Jakubowicz, C., Nash, L., Rigaut, C. and Gérard, C. L. (1998). Determiners and clitic pronouns in French-speaking children with SLI. *Language Acquisition* 7, 113-160.
- Kayne, R. (1975). *French Syntax. The Transformational Cycle*. Cambridge, Mass.: MIT Press.
- Kayne, R. (2000). *Parameters and Universals*. Oxford: Oxford University Press.
- Kempen, G. (1987). A framework for incremental syntactic tree formation. *Proceedings of the 10th international joint conference on artificial intelligence*, (pp. 655-660). San Francisco: Morgan Kaufmann.
- Kempen, G. and Hoenkamp, E. (1987). An incremental procedural grammar for sentence formulation. *Cognitive Science* 11(2), 201-258.
- Kennison, S. M. (2003). Comprehending the pronouns *her*, *him* and *his*: Implications for theories of referential processing. *Journal of Memory and Language* 49, 335-352.
- Kleinhenz, U. (1998). *On words and phrases in phonology: A comparative study with focus on German*. PhD dissertation. Universität Tübingen.
- Lapesa R. (1986 [1942]). *Historia de la Lengua Española* (9th ed). Madrid: Gredos.
- Lardiere, D. (1998). Dissociating syntax from morphology in a divergent L2 end-state grammar. *Second Language Research* 14 (4), 359-375.

- Lardiere, D. (2009). Some thoughts on a contrastive analysis of features in second language acquisition. *Second Language Research* 25 (2), 173–227.
- Legendre, G. (2000a). Morphological and Prosodic Alignment of Bulgarian Clitics. In Dekkers, J., van der Leeuw, F. and van de Weijer, J. (eds.). *Optimality Theory: Syntax, Phonology, and Acquisition* (pp. 423-462). Oxford: Oxford University Press.
- Legendre, G. (2000b). Optimal Romanian Clitics: A Cross-linguistic Perspective. In Motapanyane, V. (ed.). *Comparative Studies in Romanian Syntax* (pp. 227-26). Oxford: Elsevier.
- Levelt, W. J. M. (1989). *Speaking: From intention to articulation*. Cambridge, Mass.: MIT Press.
- Liceras, J. M. (1985). The value of clitics in non-native Spanish. *Second Language Research*, 1, 151–168.
- Menéndez Pidal, R. (1966 [1904]). *Manual de gramática histórica española* (12th ed). Madrid: Espasa-Calpe.
- Monachesi, P. (2000). Clitic placement in the Romanian verbal complex. In Gerlach, B. and Grijzenhout, J. (eds.). *Clitics in Phonology, Morphology and Syntax*. Amsterdam: John Benjamins.
- Monachesi, P. (1995). *A grammar of Italian clitics*. PhD dissertation. Tilburg University.
- Montrul, S. (1999). Activating AgrIOP in second language acquisition. In Klein, E. & Martohardjono, G. (eds.). *The development of second language grammars. A generative approach* (pp.81–108). Amsterdam: John Benjamins.
- Montrul, S. (2004). *The acquisition of Spanish. The morphosyntactic development in monolingual and bilingual L1 acquisition and adult L2 acquisition*. Amsterdam: John Benjamins.
- Nespor, M. and Vogel, I. (1986). *Prosodic phonology*. Dordrecht: Foris.
- Nevins, A. (2007). The representation of third person and its consequences for Person-Case effects. *Natural Language and Linguistic Theory* 25, 273-313.

- Nevins, A. and Săvescu, O. (2010). 'An Apparent Number Case Constraint in Romanian: The Role of Syncretism'. In Arregi, K, Fagyal, Z., Montrul, S. and Tremblay, A. (eds.). *Romance Linguistics 2008. Selected papers from the 38th Linguistic Symposium on Romance Languages (LSRL), Urbana-Champaign, April 2008* (pp. 185-200). Amsterdam: John Benjamins.
- Nichols, L. (2001). The syntactic basis of referential hierarchy phenomena: clues from languages with and without morphological case. *Lingua*, 111, 515-537.
- Nicol, F. (2005). Romance Clitic Clusters: On diachronic changes and cross-linguistic contrasts. In Heggie, L. and Ordóñez, F. (eds.). *Clitic and Affix Combinations* (pp.141-197). Amsterdam: John Benjamins.
- Nieuwenhuijsen, D. (2006). Cambios en la colocación de los pronombres átonos. In Company Company, C. (dir.) *Sintaxis histórica de la lengua española, Primera parte: La frase verbal, Vol. 2* (pp.1337-1404). Mexico D.F.: Universidad Nacional Autónoma de México/Fondo de Cultura Económica.
- Odlin, T. (1989). *Language Transfer*. Cambridge: Cambridge University Press.
- Odlin, T. (2008). Cross-Linguistic Influence. In Doughty, C. J. and Long, M. H. (eds.). *The Handbook of Second Language Acquisition*. Oxford: Blackwell.
- Ormazabal, J. and Romero, J. (2002). Some Clitic Combinations in the Syntax of Romance. *Catalan Journal of Linguistics* 1, 201-224.
- Ormazabal, J. and Romero, J. (2007). The Object Agreement Constraint. *Natural Language and Linguistic Theory* 25, 315-347.
- Ortmann, A. and Popescu, A. (2000). Romanian definite articles are not articles. In Gerlach, B. and Grijzenhout, J. (eds.) *Clitics in Phonology, Morphology and Syntax* (pp.295-324). Amsterdam: John Benjamins.
- Pablos, L. (2006). *Pre-verbal Structure Building in Romance Languages and Basque*. Ph.D. dissertation. University of Maryland.
- Penny, R. (2002). *A History of the Spanish Language* (2nd ed). Cambridge: Cambridge University Press.
- Perlmutter, D. (1971). *Deep and Surface Structure Constraints in Syntax*. New York: Holt, Rinehart and Winston.

- Pickering, M. J., and van Gompel, R.P.G. (2006). Sentence processing. In Gernsbacher, M. A. and Traxler, M. J. (eds.). *Handbook of Psycholinguistics* (pp. 455-503). San Diego: Academic Press.
- Prevost, P. and White, L. (2000). Missing surface inflection or impairment in second language acquisition? Evidence from tense and agreement. *Second Language Research*. 16 (2), 103-133.
- Pylkkänen, L. (2002). *Introducing arguments*. PhD dissertation. MIT.
- Radford, A. (1997). *Syntactic theory and the structure of English: a minimalist approach*. Cambridge: Cambridge University Press.
- Ramsden, H. (1963). *Weak Pronouns in the Early Romance Languages*. Manchester: Manchester University Press.
- Real Academia Española, Asociación de Academias de la Lengua Española. (2009). *Nueva gramática de la lengua española*. Madrid: Espasa.
- Real Academia Española. Banco de datos (CORDE) [online]. Corpus diacrónico del español. (n. d). Retrieved January 15, 2011, from <http://www.rae.es>
- Real Academia Española. Banco de datos (CREA) [online]. Corpus de referencia del español actual. (n. d). Retrieved April 10, 2007, from <http://www.rae.es>
- Renzi, L. (ed.) (1988). *Grande grammatica italiana di consultazione*. Il Mulino.
- Rezac, M. (2007). The Syntax of Eccentric Agreement: the Person Case Constraint and Absolute Displacement in Basque. *Natural Language and Linguistic Theory* 26, 61-106.
- Rezac, M. (2010). *Phi-features and the Modular Architecture of Language*. New York: Springer.
- Richards, N. (1997). *What moves when where in which language?* PhD dissertation. MIT.
- Rivas, A. (1977). *A theory of clitics*. PhD dissertation. MIT.
- Rivero, M. L. (1986). Parameters in the typology of clitics in Romance and Old Spanish. *Language* 62 (4), 774-807.

- Rivero, M. L. (1997). On two locations for complement clitic pronouns: Serbo-Croatian, Bulgarian and Old Spanish. In Kemenade, A. and Vincent, N. (eds.). *Parameters of Morphosyntactic Change* (pp. 170-206). Cambridge: Cambridge University Press.
- Rivero, M. L. (2004). Spanish Quirky Subjects, Person Restrictions and the person-Case Constraint. *Linguistic Inquiry* 35 (3), 494-502.
- Rivero, M. L. (2008). Oblique subjects and person restrictions in Spanish: A morphological approach. In D'Alessandro, R., Fischer, S. and Hrafnbjargarson, G. (eds.). *Agreement Restrictions* (pp. 215-250). Berlin: De Gruyter.
- Rivero, M. L. and Geber, D. (2003). Quirky Subjects and Person Restrictions in Romance: Romanian and Spanish. *Cahiers Linguistiques d'Ottawa* 31, 20 - 53.
- Rizzi, L. (1986). Null Objects in Italian and the Theory of pro. *Linguistic Inquiry* 17, 501-557.
- Rizzi, L. (ed). (2004). *The Structure of CP and IP: The Cartography of Syntactic Structures, Volume 2*. Oxford: Oxford University Press.
- Rohde, D. LINGER software. MIT [available at <http://tedlab.mit.edu/~dr/>]
- Sabourin, L., Stowe, L. A. and de Haan, G. J. (2006). Transfer effects in learning a second language grammatical gender system. *Second Language Research* 22 (1), 1-29.
- Saltarelli, M. (1987). The acquisition of agreement. In Bahner, W., Schildt, J. and Viehweger, D. (eds.). *Proceedings of the 14th International Congress of Linguistics*. Berlin: Akademie-Verlag.
- Săvescu, O. (2007). Challenging the Person Case Constraint: Evidence from Romanian. In Camacho, J., Flores-Ferrán, N., Sánchez, L., Déprez, V. and Cabrera M. J. (eds.). *Romance Linguistics 2006. Selected Papers from the 36th Linguistic Symposium on Romance Languages (LSRL), New Brunswick*, (pp 255-269). Amsterdam: John Benjamins.

- Săvescu, O. (2009). *A Syntactic Analysis of Pronominal Clitic Clusters in Romance: The view from Romanian*. PhD Dissertation. New York University, NY.
- Schwartz, B. and Sprouse, R. (1994). Word order and nominative case in non-native language acquisition: a longitudinal study of (L1 Turkish) German interlanguage. In T. Hoekstra & B. Schwartz (eds.). *Language acquisition studies in generative grammar* (pp. 317-368). Amsterdam: John Benjamins.
- Schwartz, B. and Sprouse, R. (1996). L2 cognitive states and the full transfer/full access model. *Second Language Research* 12, 40-72.
- Selkirk, E. (1995). The prosodic structure of function words. In Beckman, J., Walsh Dickey, L and Urbanczyk, S. (eds.). *Papers in Optimality Theory* (pp. 439-470). Amherst, Mass.: GLSA Publications.
- Seuren, P. (1976). Clitic pronoun clusters. *Italian linguistics* 2, 17-36.
- Sharwood Smith, M. (1996). Crosslinguistic influence with special reference to the acquisition of grammar. In Jordens, P. and Lalleman, J. (eds.). *Investigating second language acquisition* (pp. 71-83). Berlin: Mouton de Gruyter.
- Siegel, J. (2009). Language contact and second language acquisition. In Ritchie, W. C. and Bhatia, T. K. *The New Handbook of Second Language Acquisition* (pp.569-589). Bingley: Emerald Group Publishing.
- Sigurdsson, H. Á. (2004). The Syntax of Person, Tense and Speech Features. *Rivista di Linguistica/Italian Journal of linguistics* 16/1, 219-251.
- Sportiche (1996). Clitic Constructions. In Zaring, L. and Rooryck, J. (eds.). *Phrase Structure and the Lexicon* (pp. 213-276). Dordrecht: Kluwer.
- Strozer, J. (1976). *Clitics in Spanish*. PhD dissertation. University of California, Los Angeles.
- Torrego, E. (1995). From argumental to non-argumental pronouns: Spanish doubled reflexives. *Probus* 7(2), 221-241.
- Trueswell, J. C. (1996). The role of lexical frequency in syntactic ambiguity resolution. *Journal of Memory and Language* 35, 566-585.
- Uriagereka, J. (1995). Aspects of Clitic Placement in Western Romance. *Linguistic Inquiry* 26 (1), 79-123.

- Valenzuela, E. (2006). L2 end state grammars and incomplete acquisition of Spanish CLLD constructions. In Slabakova, R., Montrul, S. and Prévost, P. (eds.). *Special Volume in honour of Lydia White*. Amsterdam: John Benjamins.
- Wanner, D. (1987a). *The Development of Romance Clitic Pronouns: from Latin to Old Romance*. Berlin: Mouton de Gruyter.
- Wanner, D. L. (1987b). Clitic Pronouns in Italian: A Linguistic Guide. *Italica* 64 (3), 410-442.
- Wanner, D. (1999). Clitic clusters in Romance: A modest account. In Franco, J., Landa, A. and Martín, M. *Grammatical Analyses in Basque and Romance Linguistics. Papers in honor of Mario Saltarelli* (pp 257-277). Amsterdam: John Benjamins.
- White, L. (2000). Second language acquisition: from initial to final state. In John Archibald (ed.). *Second language acquisition and linguistic theory* (pp. 130-155). Oxford: Blackwell.
- White, L. (2003a). *Second language acquisition and Universal Grammar*. Cambridge: Cambridge University Press.
- White, L. (2003b). On the nature of interlanguage representation: Universal Grammar in the second language. In C. Doughty and M. Long (eds.). *Handbook of second language acquisition* (pp. 19-42). Blackwell.
- White, L. (2007). Linguistic theory, Universal Grammar and second language acquisition. In van Patten, B. and Williams, J. (eds.). *Theories in second language acquisition: an introduction* (pp. 37-55). New Jersey: Lawrence Erlbaum.
- Zagona, K. (2002). *The Syntax of Spanish*. Cambridge: Cambridge University Press.
- Zubizarreta, M. L. (1998). *Prosody, Focus, and Word Order*. Cambridge, Mass.: MIT Press.
- Zwicky, A. (1977). *On clitics*. Bloomington, IN: Indiana University Linguistics Club.
- Zwicky, A. (1985). Clitics and particles. *Language* 61 (2), 283-305.
- Zwicky, A. and Pullum, G. K. (1983). Cliticization vs. Inflection: English N'T. *Language* 59 (3), 502-513.

APPENDIX A – DIACHRONIC DATA.

CLUSTER DISTRIBUTION – CORDE

CLUSTER	1ST CLITIC: SUBJECT	2ND CLITIC: SUBJECT	1ST CLITIC: PREPOSITION	NPBE COMPLIANT	NPBE VIOLATION	AMBIGUOUS /UNCLEAR	NO CLUSTER	OTHER¹¹⁶	TOTAL
TE ME	-	-	-	724	-	-	-	-	724
OS NOS	-	-	-	-	-	-	-	-	0
NOS OS	8	-	8	-	-	-	3	7	26
VOS NOS	142	24	47	1	-	-	5	24	243
NOS VOS	392	14	52	-	-	5	8	15	486
TE NOS	-	-	-	72	-	-	-	-	72
NOS TE	23	-	-	-	-	-	-	13	36
OS ME	-	-	-	69	9	8	-	10	96
ME OS	-	-	-	19	-	1	-	6	26
VOS ME	1174	-	492	-	-	9	-	-	1675
ME VOS	-	211	-	64	-	4	-	-	279

¹¹⁶ This category includes enumerations, sentences in languages other than Spanish (e.g. Latin, Galician), cases in which the two clitics belong to different sentences, etc.

APPENDIX B

1) GRAMMATICALITY JUDGMENT TASK – EXPERIMENTAL ITEMS

Combinations of accusative and non-argumental dative (ACC-NAD)

- a) Federico, hijo, no te enfades con Paco y Marcelo...
...ya sé que te empujaron y **te me** tiraron al suelo, pero fue sin querer.
Federico, son, don't get mad at Paco and Marcelo...
... I know they pushed you and threw you to the floor, but it was not on purpose.
- b) Federico, hijo, no te enfades con Paco y Marcelo...
...ya sabemos que te empujaron y **te nos** tiraron al suelo, pero fue sin querer.
Federico, son, don't get mad at Paco and Marcelo...
... we know they pushed you and threw you to the floor, but it was not on purpose.
- c) Hijos, no os enfadéis con Paco y Marcelo...
...ya sabemos que os empujaron y **os nos** tiraron al suelo, pero fue sin querer.
Kids, don't get mad at Paco and Marcelo...
... we know they pushed you and threw you (pl) to the floor, but it was not on purpose.
- d) Hijos, no os enfadéis con Paco y Marcelo...
...ya sé que os empujaron y **os me** tiraron al suelo, pero fue sin querer.
Kids, don't get mad at Paco and Marcelo...
... I know they pushed you and threw you (pl) to the floor, but it was not on purpose.

Combinations of dative and non-argumental dative (DAT-NAD)

- a) Esta prima que tienes es incorregible...
...otra vez **te me** ha pintado la cara de payaso.
This cousin of yours is impossible...
... she painted a clown face on you again.
- b) Esta prima que tienes es incorregible...
...otra vez **te nos** ha pintado la cara de payaso.
This cousin of yours is impossible...
... she painted a clown face on you again.
- c) Estas primas que tenéis son incorregibles...
...otra vez **os nos** han pintado la cara de payaso.
These cousins of yours are impossible...
... they painted a clown face on you (pl) again.
- d) Estas primas que tenéis son incorregibles...
...otra vez **os me** han pintado la cara de payaso.
These cousins of yours are impossible...
... they painted a clown face on you (pl) again.

Combinations of reflexive and non-argumental dative (REFL-NAD)

- a) Hijo, siempre insisto en que lleves gorro, bufanda y guantes en cuanto baja la temperatura.
... porque **te me** vas a resfriar si no vas bien abrigado.
Son, I always say that you have to wear a hat, scarf and mittens as soon as the temperature drops...
... because you are going to catch a cold if you don't dress warm.

- b) Hijo, papá y yo insistimos en que lleves gorro, bufanda y guantes en cuanto baja la temperatura.
 ... porque **te nos** vas a resfriar si no vas bien abrigado.
Son, Dad and I always say that you have to wear a hat, scarf and mittens as soon as the temperature drops...
... because you are going to catch a cold if you don't dress warm.
- c) Hijos, papá y yo insistimos en que llevéis gorro, bufanda y guantes en cuanto baja la temperatura...
 ... porque **os nos** vais a resfriar si no vais bien abrigados.
Kids, Dad and I always say that you have to wear a hat, scarf and mittens as soon as the temperature drops...
... because you (pl) are going to catch a cold if you (pl) don't dress warm.
- d) Hijos, siempre insisto en que llevéis gorro, bufanda y guantes en cuanto baja la temperatura...
 ... porque **os me** vais a resfriar si no vais bien abrigados.
Kids, I always say that you have to wear a hat, scarf and mittens as soon as the temperature drops...
... because you (pl) are going to catch a cold if you (pl) don't dress warm.

Combinations of reflexive and dative (REFL-DAT)

- a) Iba a comprar la última copia de esa película que me gusta tanto...
 ... pero **te me** adelantaste y la compraste tú primero.
I was going to buy the last copy of that movie I like so much...
... but you got ahead of me and bought it first.
- b) Íbamos a comprar la última copia de esa película que nos gusta tanto...
 ... pero **te nos** adelantaste y la compraste tú primero.

*We were going to buy the last copy of that movie we like so much...
... but you got ahead of us and bought it first.*

- c) Íbamos a comprar la última copia de esa película que nos gusta tanto...
... pero **os nos** adelantasteis y la comprasteis vosotros primero
*We were going to buy the last copy of that movie we like so much...
... but you (pl) got ahead of us and bought it first.*

- d) Iba a comprar la última copia de esa película que me gusta tanto...
... pero **os me** adelantasteis y la comprasteis vosotros primero.
*I was going to buy the last copy of that movie I like so much...
... but you (pl) got ahead of me and bought it first.*

2) GRAMMATICALITY JUDGMENT TASK – CONTROL ITEMS

Combinations of non-argumental dative and accusative (NAD-ACC)

Parecía que Pepón no iba a encontrar trabajo y, al final...
... **nos lo** han contratado en una de las empresas más importantes del país.
*It looked as if Pepón was not going to find a job and now...
...he got hired at one of the most important companies in the country.*

Combinations of dative and non-argumental dative (DAT-NAD)

El pobre Simón está muy decepcionado...
... porque **nos le** han robado la moto esta mañana.
*Poor Simon is very disappointed...
...because his motorbike got stolen this morning.*

Combinations of reflexive and non-argumental dative (REFL-NAD)

Vaya, parece que el abono nuevo que usáis en el jardín funciona muy bien...
... porque las plantas **se os** han puesto hermosas en sólo tres semanas.
*Well, it looks like the fertilizer you use in the garden Works very well...
... because your plants got beautiful in just three weeks.*

Combinations of reflexive and dative (REFL-DAT)

No notaste que Marina estaba a tu lado porque...

... **se te** acercó sin que la vieras.

You didn't notice that Marina was by your side...

... because she got close to you without you seeing her.

3) GRAMMATICALITY JUDGMENT TASK – FILLER ITEMS

SAMPLE ITEM 1

Deja de molestarme cuando estoy trabajando...

...no **te lo** voy a repetir más veces.

Stop bothering me while I'm working...

...I won't tell you again.

SAMPLE ITEM 2

Es imposible que Alicia tenga esos testimonios...

...porque **me** entregaron **a mí** todos los documentos relacionados con el caso.

It's imposible that Alicia has those statements...

... because they gave me all the documents related to that case.

SAMPLE ITEM 3

Ya sé que estás muy preocupado porque nuestro edificio no tiene cafetería...

... pero, si quieres café, puedes prepararlo **en** la cocina del trabajo.

I know you are very worried that our building doesn't have a cafeteria...

... but if you want coffee, you can make some in the office's kitchen.

SAMPLE ITEM 4

Ramón y Ramona están organizando un coloquio sobre el cine de Akira Kurosawa...

... porque siempre **les** ha fascinado el cine japonés.

Ramón and Ramona are organizing a colloquium about Akira Kurosawa's filmography

... because Japanese cinema has always fascinated them.

APPENDIX C

SPANISH L2 – SELF-PACED READING EXPERIMENT –5-CONDITION ANALYSIS

ENGLISH GROUP

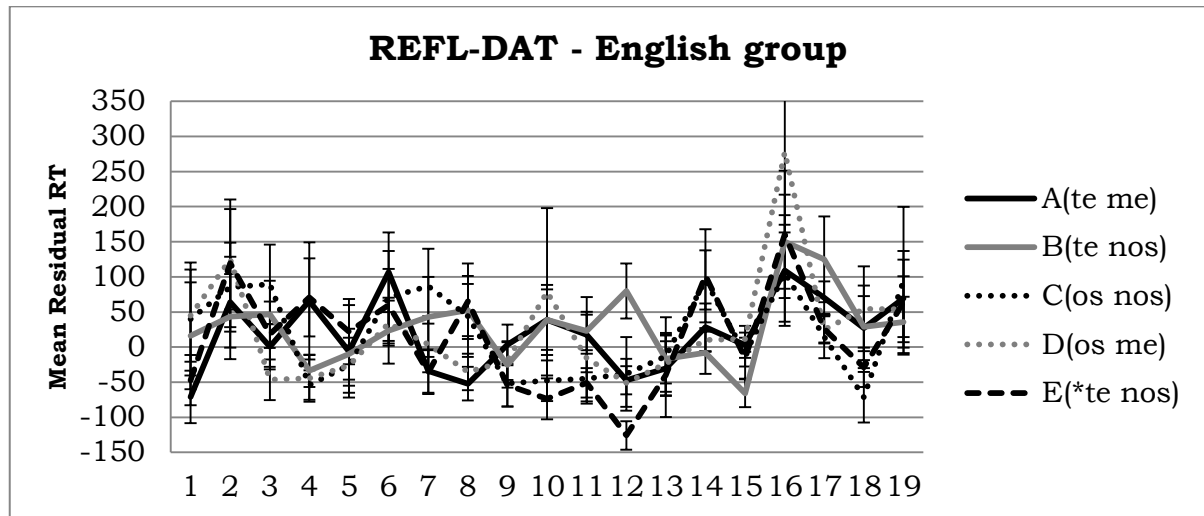

Figure AP 1. REFL-DAT grouped (5 conditions). English group

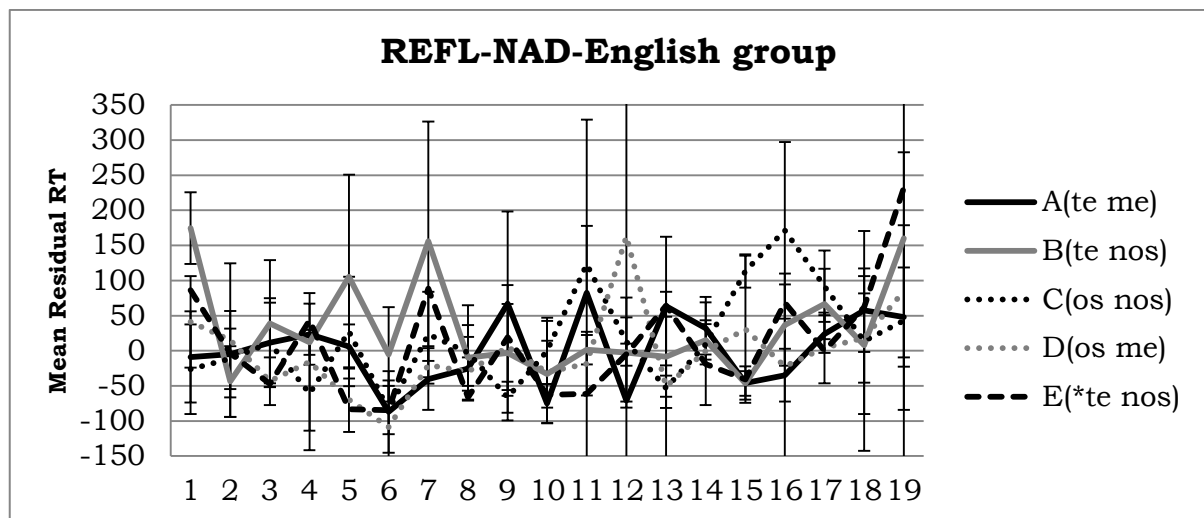

Figure AP 2. REFL-NAD grouped (5 conditions). English group

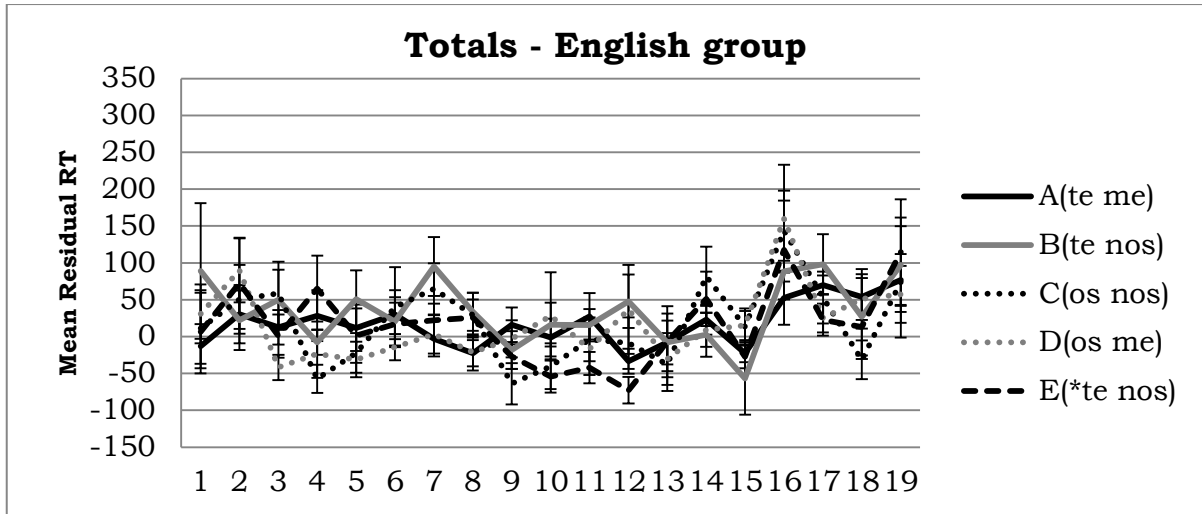

Figure AP 3. Totals grouped (5 conditions). English group

2x5 repeated measures ANOVA for each region. Summary of results for critical regions:

Region 14:

- No main effect for structure type ($F(1,16)=3.070, p=.099$)
- No main effect for cluster type ($F(4,64)=1.210, p=.315$)
- No significant interaction between the structure and cluster factors ($F(4,64)=1.399, p=.244$)

Region 15:

- No main effect for structure type ($F(1,18)=.472, p=.502$)
- No main effect for cluster type ($F(4,64)=2.150, p=.085$)
- No significant interaction structure-cluster ($F(4,64)=1.600, p=.185$)

Region 16:

- No main effect for structure type ($F(1,16)=2.328, p=.147$)
- No main effect for cluster type ($F(4,64)=.540, p=.707$)
- No significant interaction structure-cluster ($F(4,64)=1.732, p=.707$)

Region 17:

- No main effect for structure type ($F(1,16)=1.279, p=.275$)
- No main effect for cluster type ($F(4,64)=.956, p=.438$)
- No significant interaction structure-cluster ($F(4,64)=1.030, p=.398$)

FRENCH GROUP

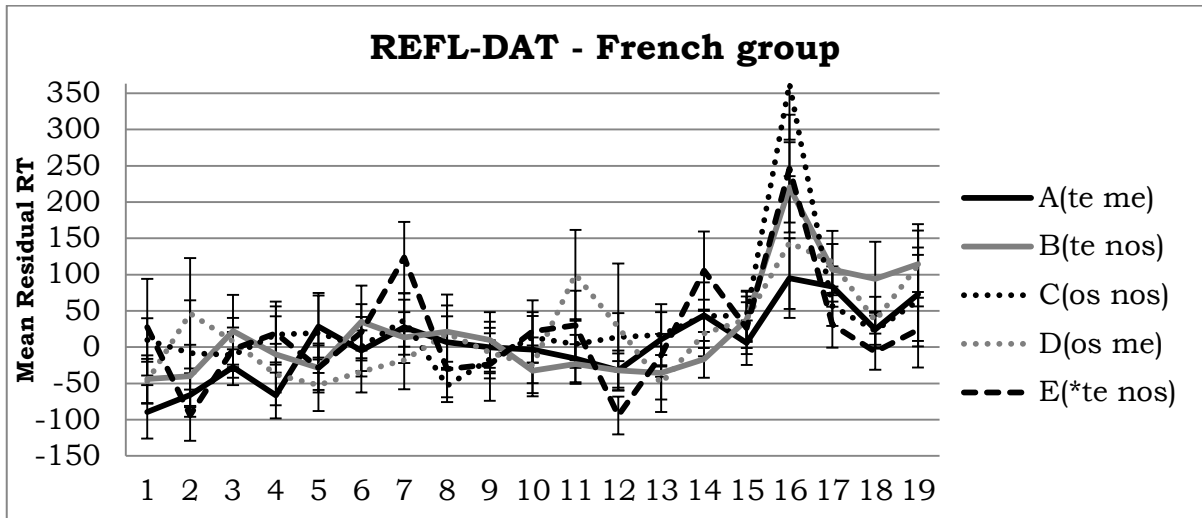

Figure AP 4. REFL-DAT grouped (5 conditions). French group

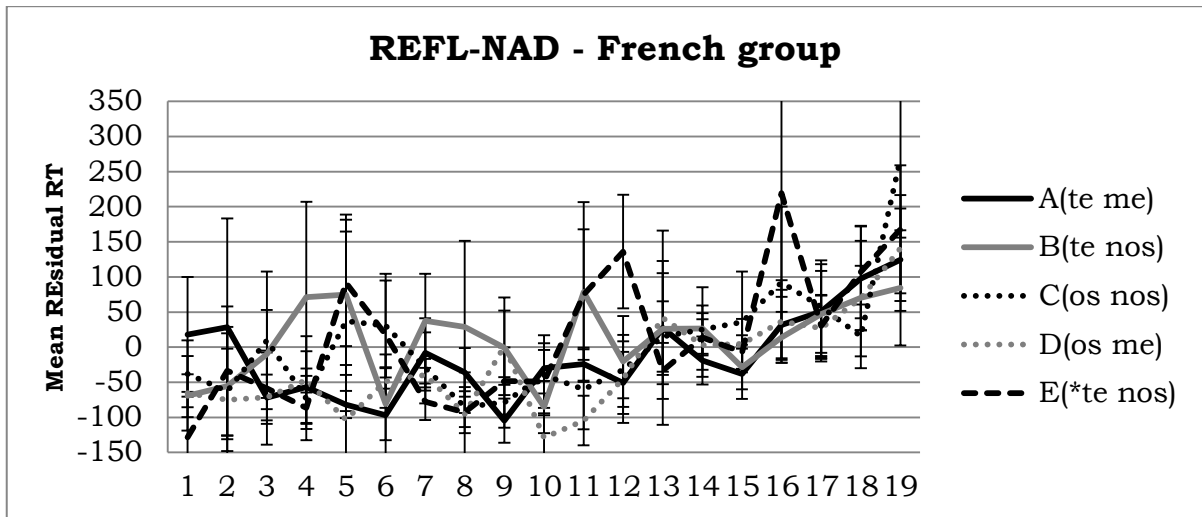

Figure AP 5. REFL-NAD grouped (5 conditions). French group

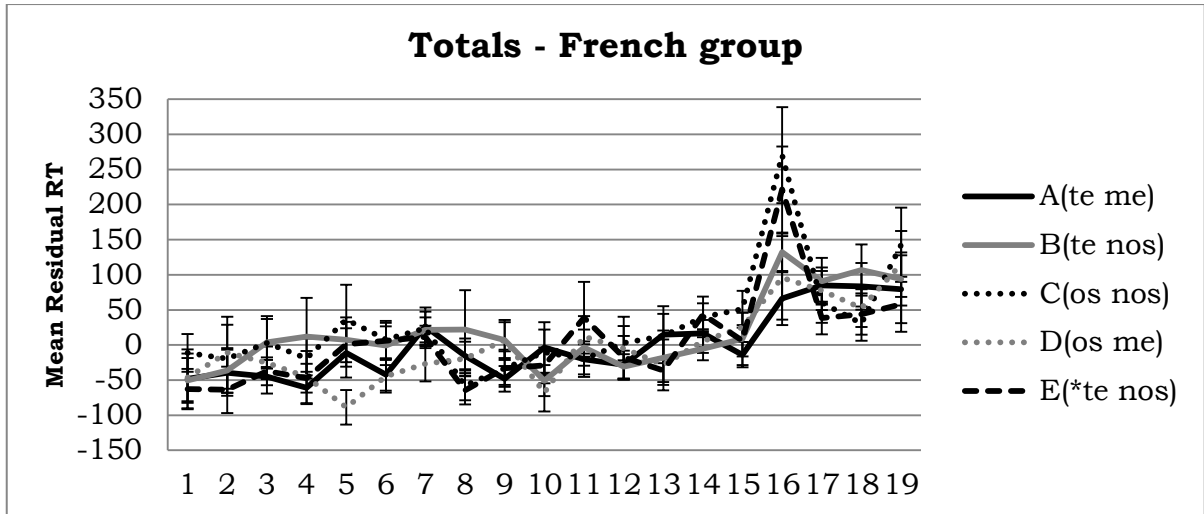

Figure AP 6. Totals grouped (5 conditions). French group

2x5 repeated measures ANOVA for each region. Summary of results for critical regions:

Region 14:

- No main effect for structure type ($F(1,19)=2.123$ $p=.161$)
- No main effect for cluster type ($F(4,76)=1.356$ $p=.257$)
- No significant interaction structure-cluster ($F(4,76)=1.094$ $p=.366$)

Region 15:

- No main effect for structure type ($F(1,19)=2.687$ $p=.118$)
- No main effect for cluster type ($F(4,76)=.969$ $p=.430$)
- No significant interaction structure-cluster ($F(4,76)=.345$ $p=.847$)

Region 16:

- A main effect for structure type ($F(1,19)=7.832$ $p=.011$)
- A main effect for cluster type ($F(4,76)=2.689$ $p=.037$)
 - Pairwise comparisons¹¹⁷ reveal no further significant differences
- No significant interaction structure-cluster ($F(4,76)= 1.424$ $p=.234$)

Region 17:

- A main effect for structure type ($F(1,19)=13.105$ $p=.002$)
- No main effect for cluster type ($F(4,76)=.417$ $p=.796$)
- No significant interaction structure-cluster ($F(4,76)=.517$ $p=.723$)

¹¹⁷ All pairwise comparisons were performed using the Bonferroni correction.

ROMANIAN GROUP

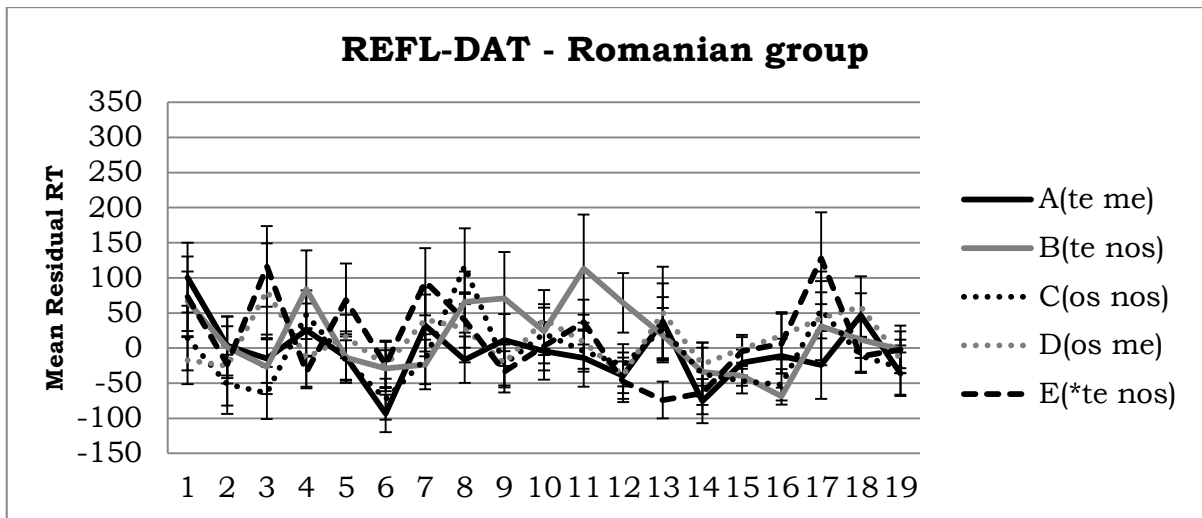

Figure AP 7. REFL-DAT grouped (5 conditions). Romanian group

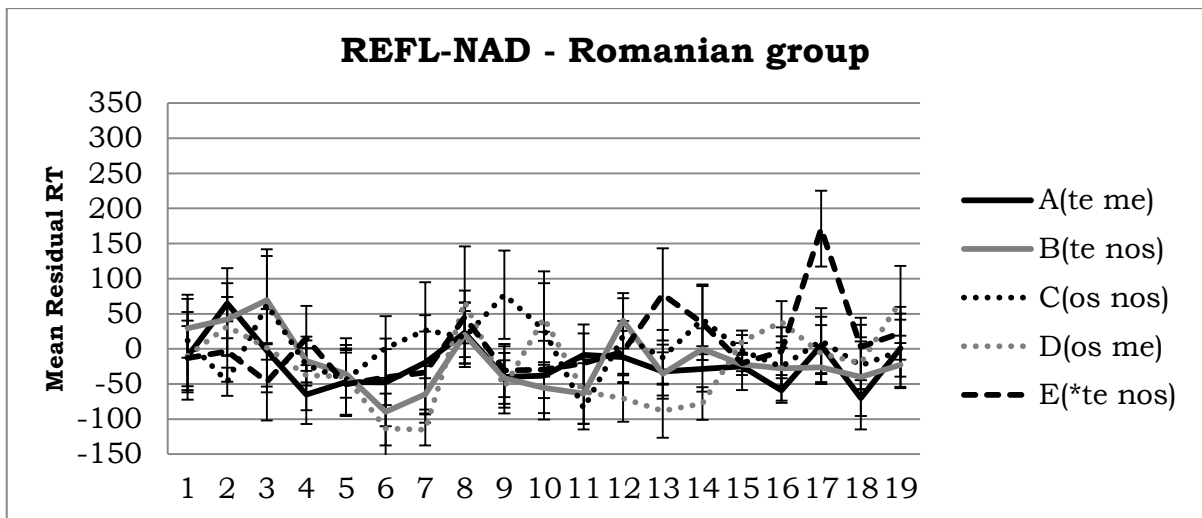

Figure AP 8. REFL-NAD grouped (5 conditions). Romanian group

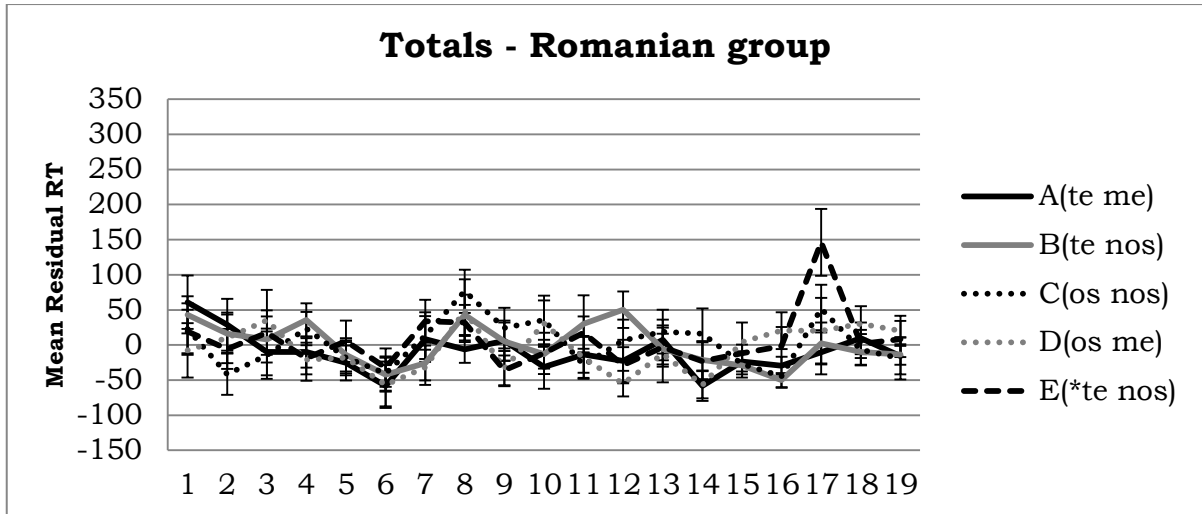

Figure AP 9. Totals grouped (5 conditions). Romanian group

2x5 repeated measures ANOVA for each region. Summary of results for critical regions:

Region 14:

- A main effect for structure type ($F(1,20)=4.066$ $p=.057$)
- No main effect for cluster type ($F(4,80)=1.193$ $p=.320$)
- No significant interaction structure-cluster ($F(4,80)=2.135$ $p=.084$)

Region 15:

- No main effect for structure type ($F(1,20)=.903$ $p=.353$)
- No main effect for cluster type ($F(4,80)=1.112$ $p=.357$)
- No significant interaction structure-cluster ($F(4,80)=.516$ $p=.724$)

Region 16:

- No main effect for structure type ($F(1,20)=.061$ $p=.808$)
- No main effect for cluster type ($F(4,80)=2.437$ $p=.054$)
- No significant interaction structure-cluster ($F(4,80)=2.437$ $p=.725$)

Region 17:

- No main effect for structure type ($F(1,20)=.262$ $p=.614$)
- A main effect for cluster type ($F(4,80)=4.178$ $p=.004$)
 - Pairwise comparisons reveal significant differences between: “te me” and “*te nos” ($p=.017$), “te nos” and “*te nos” ($p=.026$)
- No significant interaction structure-cluster ($F(4,80)=.811$ $p=.522$)

ALL GROUPS

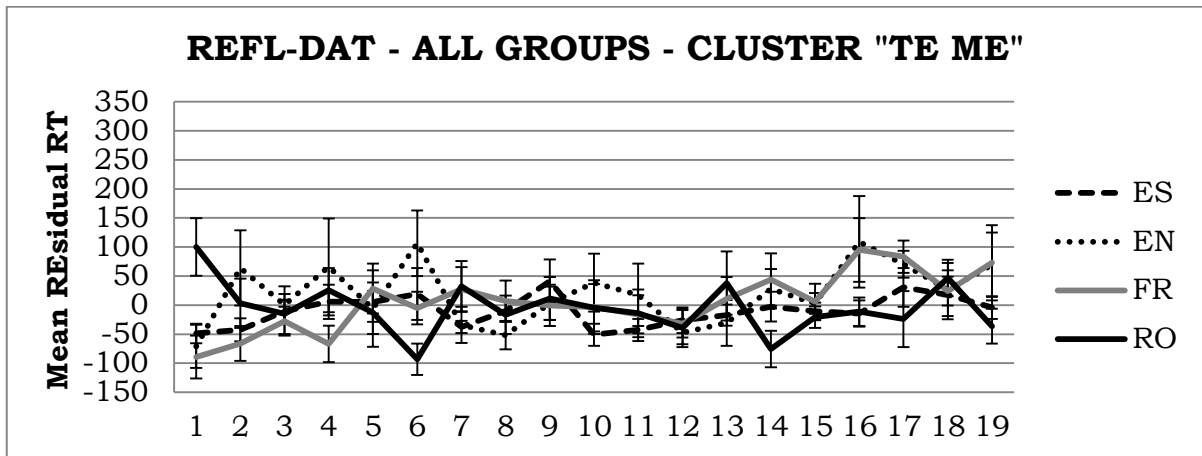

Figure AP 10. Totals all groups, cluster "te me"

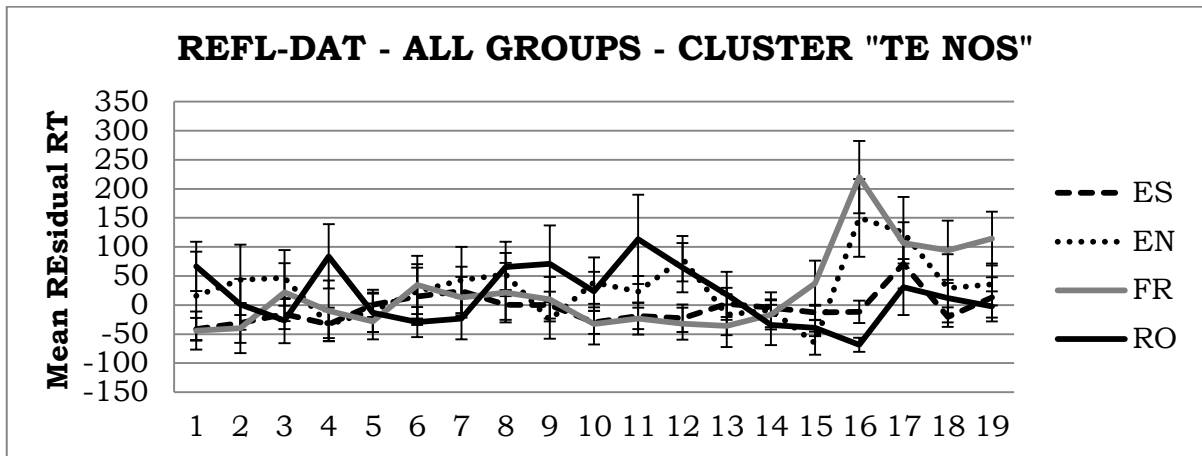

Figure AP 11. Totals all groups, cluster "te nos"

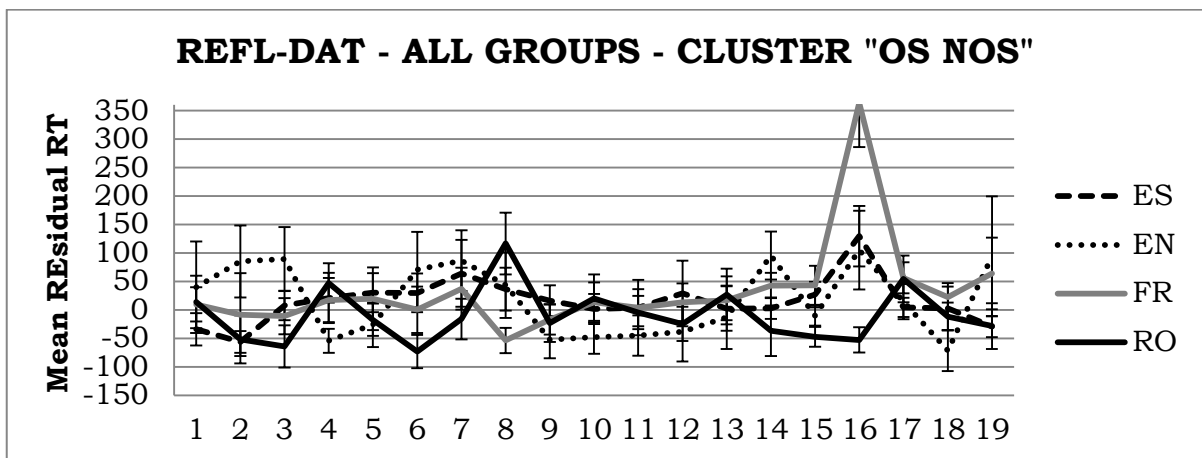

Figure AP 12. Totals all groups, cluster "os nos"

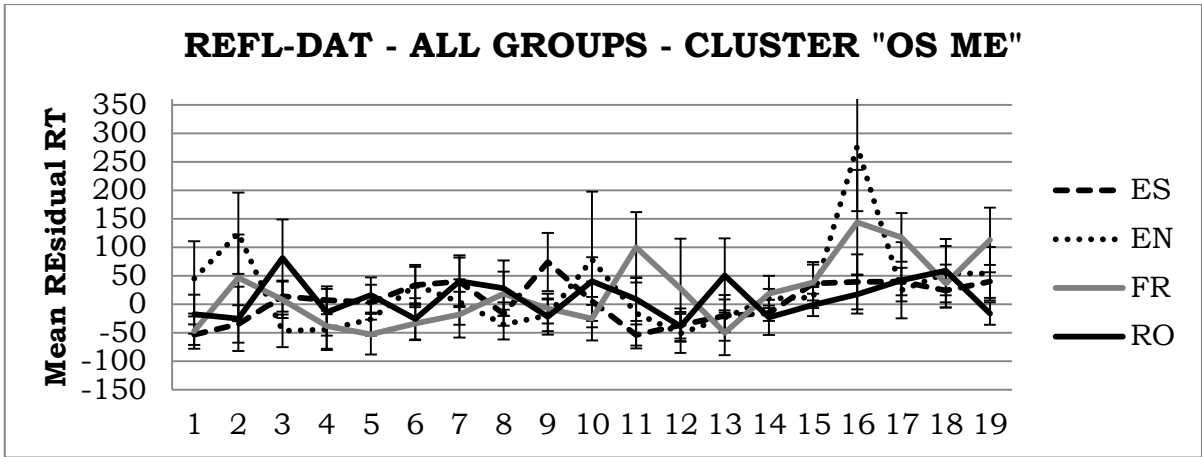

Figure AP 13. Totals all groups, cluster "os me"

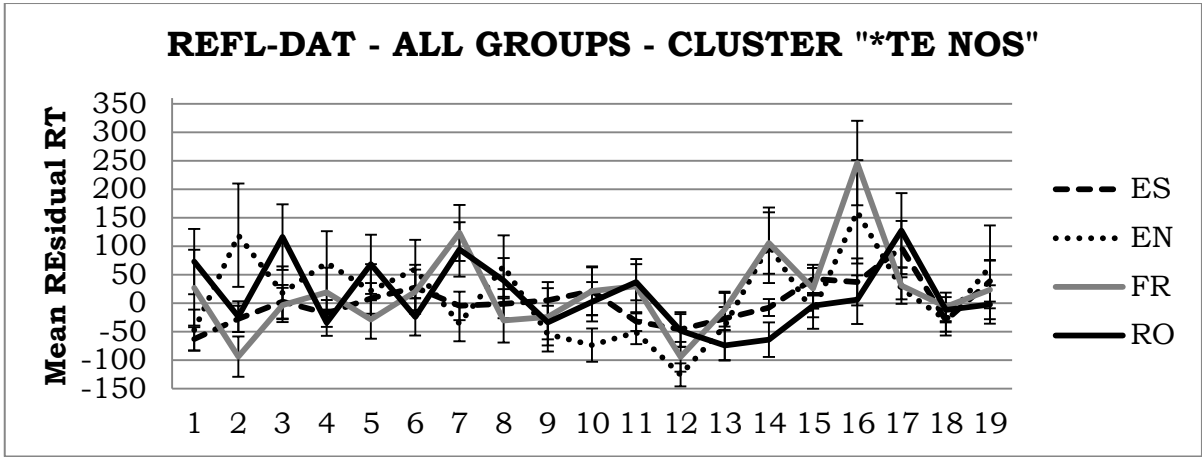

Figure AP 14. Totals all groups, cluster "*te nos"

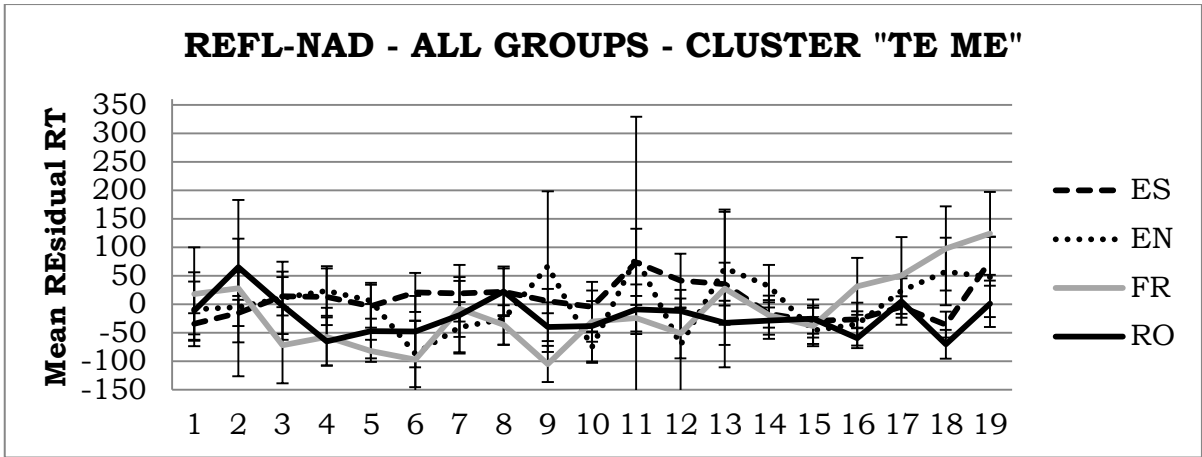

Figure AP 15. REFL-NAD all groups, cluster “te me”

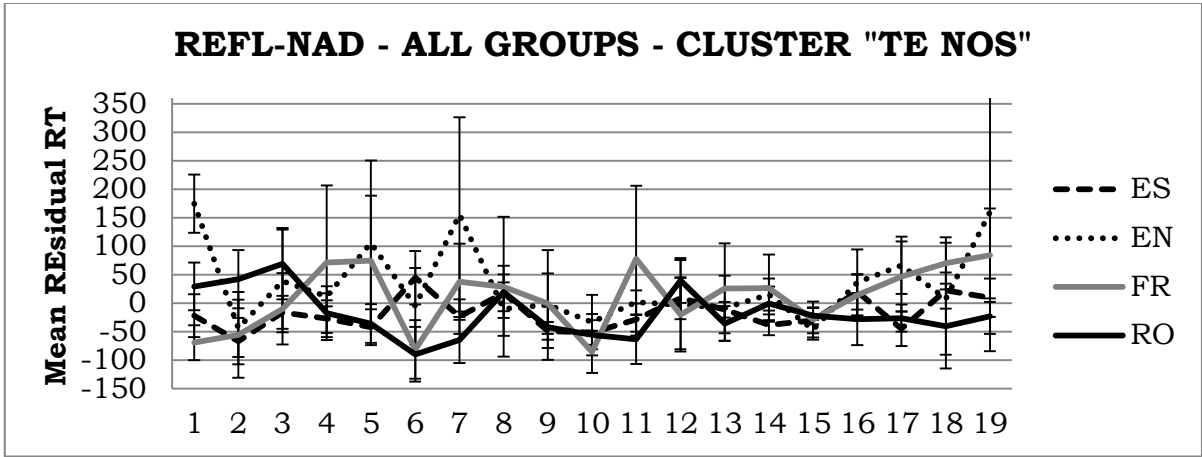

Figure AP 16. REFL-NAD all groups, cluster “te nos”

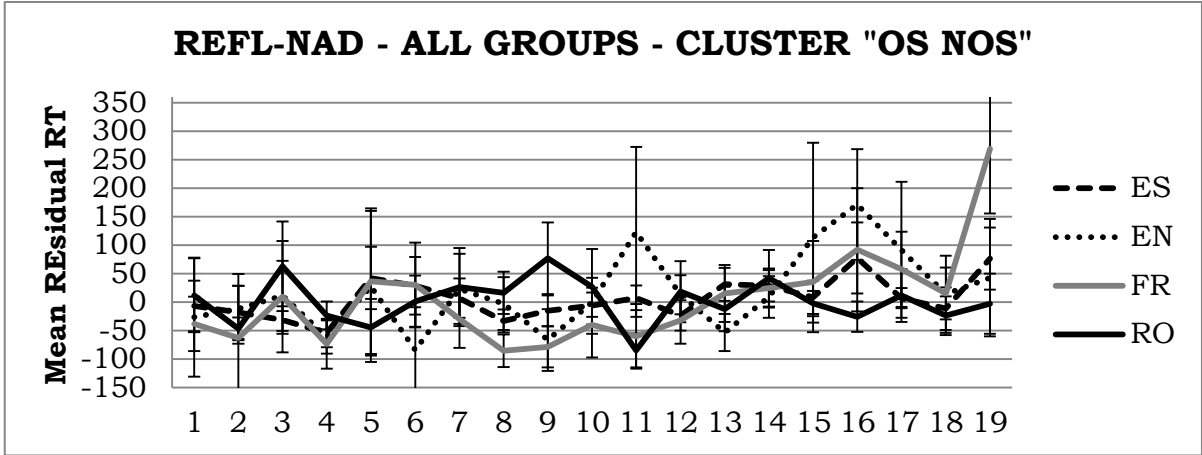

Figure AP 17. REFL-NAD all groups, cluster “os nos”

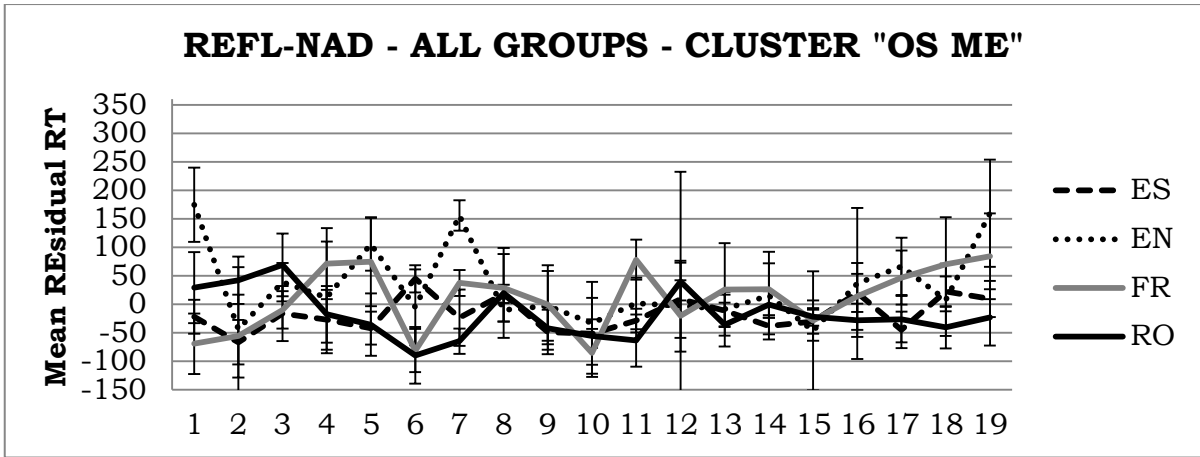

Figure AP 18. REFL-NAD all groups, cluster "os me"

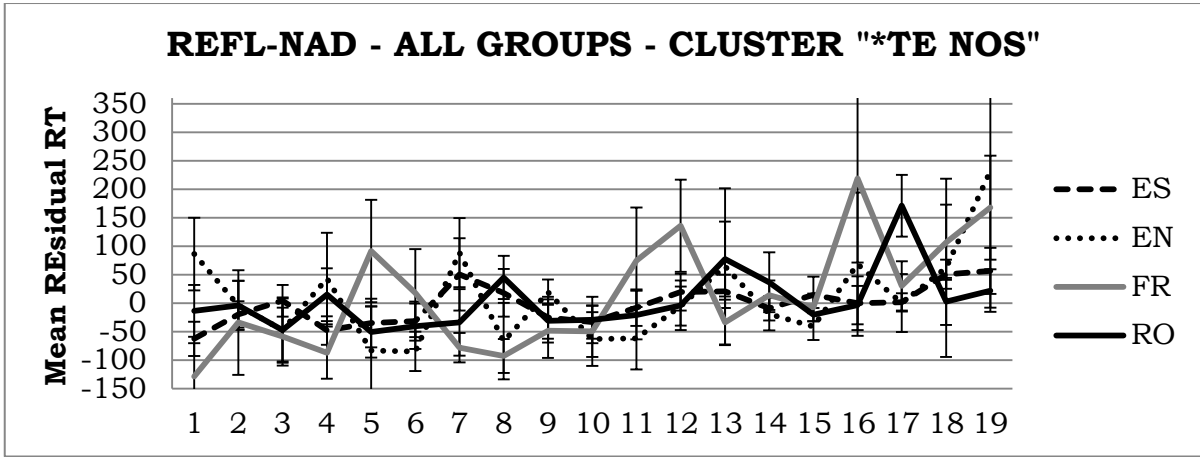

Figure AP 19. REFL-NAD all groups, cluster "*te nos"

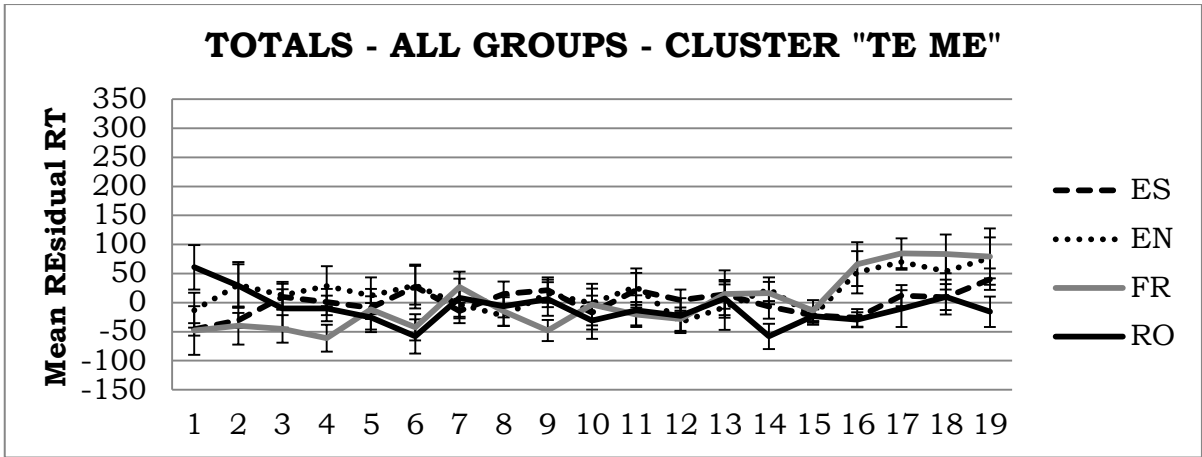

Figure AP 20. REFL-DAT all groups, cluster "te me"

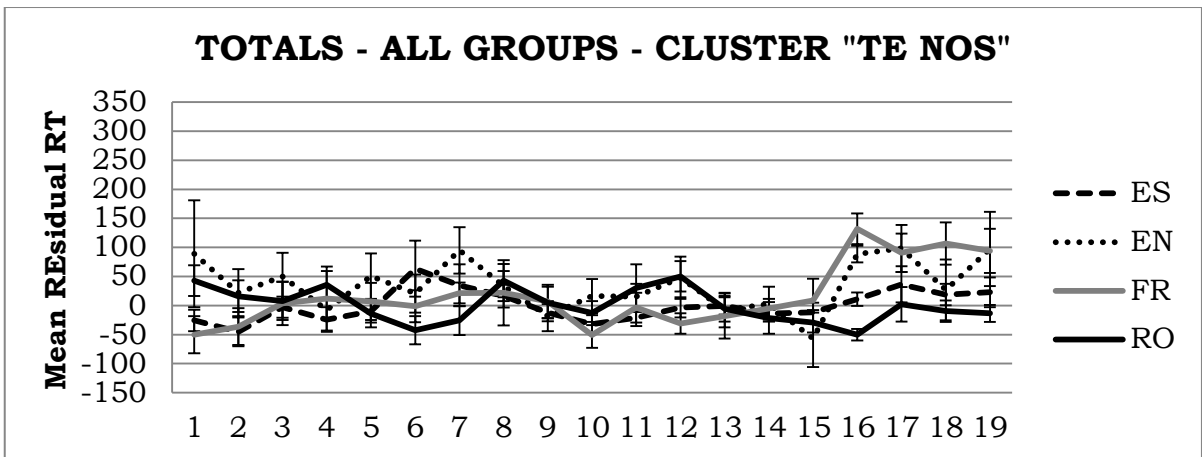

Figure AP 21. REFL-DAT all groups, cluster "te nos"

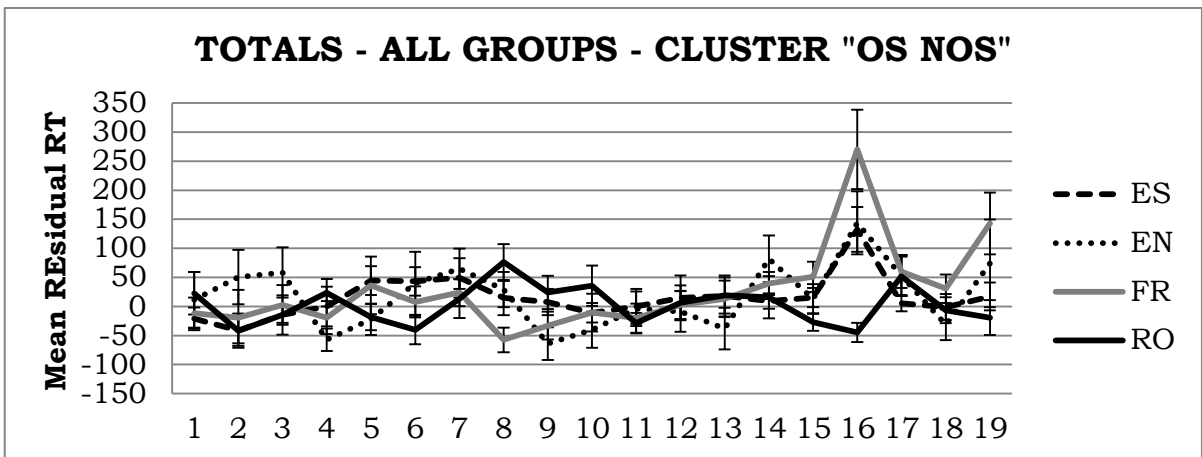

Figure AP 22. REFL-DAT all groups, cluster "os nos"

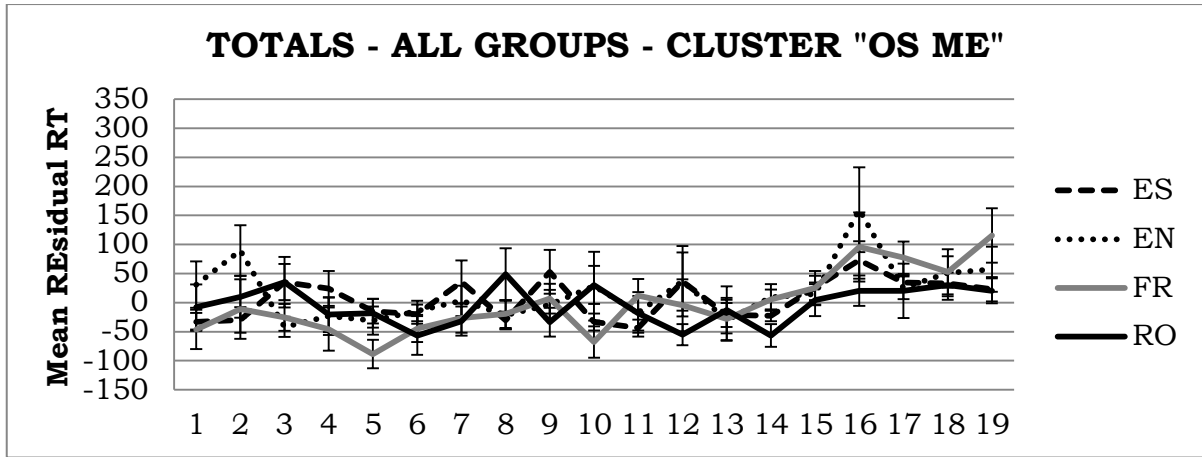

Figure AP 23. REFL-DAT all groups, cluster “os me”

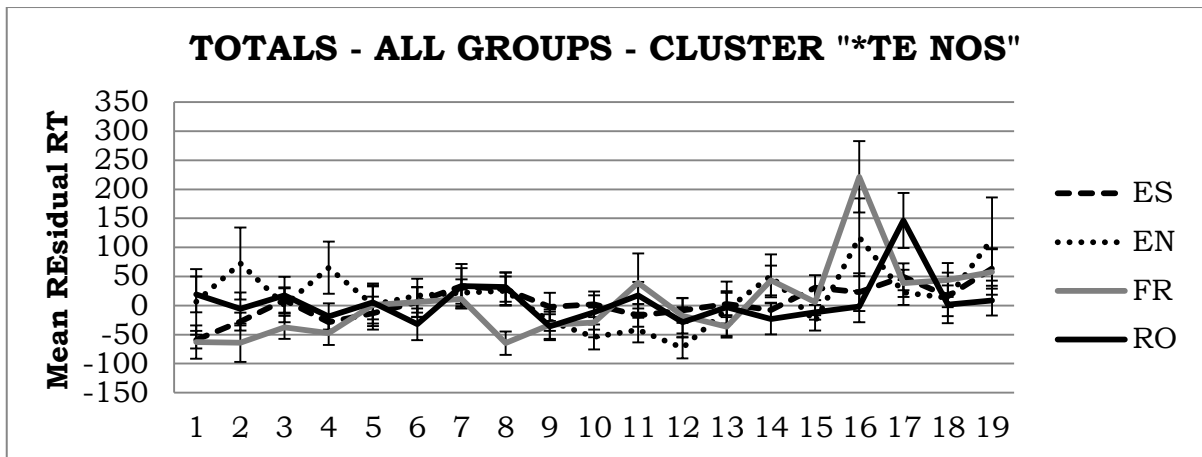

Figure AP 24. REFL-DAT all groups, cluster “*te nos”

3-way mixed ANOVA for each region (structure type and cluster type as the within-subject factors; group as the between-subject factor). Summary of results for critical regions:

Region 14:

- No main effect for structure type ($F(1,63)=.439$ $p=.510$)
- No significant interaction between the structure and group factors ($F(3,63)=2.741$ $p=.051$).
- A main effect for cluster type ($F(4,252)=2.553$ $p=.040$)
 - Pairwise comparisons reveal no further significant differences
- No significant interaction between the cluster and group factors ($F(12,252)=.522$ $p=.899$)

- No significant interaction between the structure and cluster factors ($F(4,252)=1.035$ $p=.389$)
- Significant interaction between the structure, cluster and group factors ($F(12,252)=2.198$ $p=.012$)
- Test of between-subjects effects: A main effect for group ($F(3,63)=4.436$ $p=.007$).
 - Pairwise comparisons reveal significant differences between the French and Romanian groups ($p=.008$)

Region 15:

- No main effect for structure type ($F(1,63)=.241$ $p=.626$)
- No significant interaction structure-group ($F(3,63)=1.395$ $p=.253$)
- A main effect for cluster type ($F(4,252)=3.380$ $p=.010$)
 - Pairwise comparisons reveal no further significant differences
- No significant interaction cluster-group ($F(12,252)=.938$ $p=.509$)
- No significant interaction structure-cluster ($F(4,252)=2.319$ $p=.058$)
- No significant interaction structure-cluster-group ($F(12,252)=.780$ $p=.671$)
- Test of between-subjects effects: No main effect for group ($F(3,63)=1.182$ $p=.324$).

Region 16:

- A main effect for structure type ($F(1,63)=6.983$ $p=.010$)
- No significant interaction structure-group ($F(3,63)=1.931$ $p=.134$)
- A main effect for cluster type ($F(4,252)=5.140$ $p=.001$)
 - Pairwise comparisons reveal significant differences between: “te me” and “os nos” ($p=.019$), “te me” and “*te nos” ($p=.042$), “te nos” and “os nos” ($p=.046$).
- No significant interaction cluster-group ($F(12,252)=1.481$ $p=.132$)
- No significant interaction structure-cluster ($F(4,252)=.469$ $p=.758$)
- A significant interaction structure-cluster-group ($F(12,252)=1.958$ $p=.029$)
- Test of between-subjects effects: a main effect for group ($F(3,63)=6.839$ $p<.001$)
 - Pairwise comparisons reveal significant differences between: Spanish and French g ($p=.011$), French and Romanian ($p=.001$), English and Romanian ($p=.046$)

Region 17:

- A main effect for structure type ($F(1,63)=11.305$ $p=.001$)
- No significant interaction structure-group ($F(3,63)=.675$ $p=.570$)
- No main effect for cluster type ($F(4,252)=.664$ $p=.617$)
- A significant interaction cluster-group ($F(12,252)=1.932$ $p=.031$)
- No significant interaction structure-cluster ($F(4,252)=1.932$ $p=.123$)
- No significant interaction structure-cluster-group ($F(12,252)=.972$ $p=.476$)
- Test of between-subjects effects: no main effect for group ($F(3,63)=1.323$ $p=.275$)