

ACKNOWLEDGEMENTS

The author wishes to express his gratitude to Professor L. P. Dugal for his advice and criticisms in the matter of detail and of general organization.

To Dr. H. N. MacFarland* of the Department of National Health and Welfare, Ottawa, the author is deeply indebted for his invaluable guidance in both the theoretical and practical aspects of this research project.

Sincere thanks are extended to Mr. G. F. Dowd for designing the electronic devices and to Mrs. K. J. Leong for her skilful technical assistance.

* Present Address: Hasleton Laboratories, Inc., Falls Church, Va., U.S.A.

STATEMENT OF THE PROBLEM

The limitation of using Ct (the product of concentration and exposure time) as a measure of dosage of gaseous substances is well recognized. On the other hand, with the dosimetric method, which has the merit of taking various relevant respiratory parameters into consideration, difficulties are encountered in measuring the ventilatory volumes without imposing severe strain on the experimental animal, and in collecting a sample of expired air containing a sufficient amount of toxicant for analysis. In this latter technique it is generally considered the percent retention (α) of a given gas by the pulmonary system of a given species of animal is constant. The present investigation is to test the validity of this assumption and to study the inter-relationship between various ventilatory parameters. The programme of research envisaged requires the development of instrumentation for displaying the respiratory dynamics of small animals under relatively normal and physiological conditions. In addition, the measurement of α requires an analytical system which will permit detection of the difference in concentration of the agent in the inspired and expired air of the animal. Finally, it is considered desirable to obtain tracings of various measurements continuously and simultaneously so that the percent retention can be calculated and compared with respect to time and at different levels of the agent.

ABSTRACT

An open-circuit, valveless, continuous air-flow respirographic technique has been developed for measuring the tidal volume, minute volume, respiratory rate and respiratory air-flow pattern simultaneously and continuously. Several electronic devices have been designed to provide the necessary resolving power in this measuring system. The various respiratory parameters of unanaesthetized young adult rats have been measured under experimental conditions which approach normal physiological conditions more nearly than in any earlier techniques. The correlation between tidal volume, minute volume and body weight, as expressed in various mathematical functions, has been re-examined and discussed.

In addition, an analytical system capable of recording continuously and practically instantaneously changes in sulphur dioxide concentration in air has been developed. The method requires a relatively small volume of gas sample for analysis. Contaminated air reacts with acidified hydrogen peroxide solution in a specially designed counter-current absorber to form sulphuric acid. The impedance of the effluent bears an inverse relationship to the amount of sulphur dioxide being absorbed in the range 0-500 p.p.m.

Finally, these techniques have been adapted for determining simultaneously the pulmonary dynamics and retention of sulphur dioxide gas by unanaesthetized rats. The effects of concentration of the agent and the duration of the exposure upon the percent

retention, respiratory rate, tidal volume and minute volume of the experimental animal have been examined. The inter-relationships between these parameters have been discussed with some references to histo-pathological studies. The most striking finding is the inverse relationship between percent retention and the concentrations of sulphur dioxide, and the duration of the inhalation exposure. Consequently, these results contribute to a better concept of dose-response phenomena in the field of inhalation toxicology.

retention, respiratory rate, tidal volume and minute volume of the experimental animal have been examined. The inter-relationships between these parameters have been discussed with some references to histo-pathological studies. The most striking finding is the inverse relationship between percent retention and the concentrations of sulphur dioxide, and the duration of the inhalation exposure. Consequently, these results contribute to a better concept of dose-response phenomena in the field of inhalation toxicology.

TABLE OF CONTENTS

CHAPTER ONE

A NEW TECHNIQUE FOR TIDAL VOLUME MEASUREMENT IN UNANESTHETIZED
SMALL ANIMALS

PART I. LITERATURE SURVEY

I. Introduction.....	1
II. Review of Methods.....	1
A. Indirect Methods.....	1
(i) Oxygen Consumption Method.....	1
(ii) Electrical Impedance Spirometer.....	2
(iii) Magnetic Field Device.....	2
(iv) Barometric Method.....	2
(v) Body Plethysmograph Techniques.....	3
B. Direct Methods.....	3
(i) Valve Methods.....	3
(ii) Respirograph Methods.....	4
(iii) Air Flow Methods.....	4
III. Comments on Various Techniques.....	5
IV. Objective of Present Studies.....	6

PART II. EXPERIMENTAL RESEARCH

I. Materials and Methods.....	7
A. Electrical System.....	7
B. Tidal Volume Measurement System.....	10
C. Calibration.....	12
D. Animal Holding Device.....	14
E. Choice of Animals.....	14

II. Experimental Procedures.....	14
III. Results.....	16
IV. Discussion and Conclusions.....	18

CHAPTER TWO

A NEW ANALYTICAL TECHNIQUE FOR SULFUR DIOXIDE IN AIR

PART I. LITERATURE SURVEY

I. Introduction.....	24
II. Review of Methods.....	24
A. Wet Chemical Methods.....	24
(i) Iodimetric Methods.....	24
(ii) Acidometric Methods.....	25
(iii) Colorimetric Methods.....	25
(iv) Conductometric Method.....	26
B. Automatic Instruments.....	26
(i) Semi-Automatic Analyzers.....	26
(ii) Automatic Analyzers.....	26
III. Comments on Various Techniques.....	28
IV. Objective of Present Studies.....	28

PART II. EXPERIMENTAL RESEARCH

I. Materials and Methods.....	30
A. Analytical System.....	30
B. Electrical System.....	33
II. Experimental Procedures.....	35
III. Results and Discussion.....	38
A. Efficiency.....	38
B. Sensitivity and Range.....	38

C. Rate of Response.....	39
D. Interference.....	39
E. Applicability.....	41

CHAPTER THREE

PULMONARY RETENTION OF SULPHUR DIOXIDE BY THE RAT

PART I. LITERATURE SURVEY

I. Introduction.....	43
II. Sulphur Dioxide.....	45
III. Reviews on Sulphur Dioxide Studies.....	45
A. Symptomatic and Pathological Aspect.....	45
B. Percent Retention Studies.....	46
IV. Comments on Percent Retention Studies.....	47

PART II. EXPERIMENTAL RESEARCH

I. Materials and Methods.....	49
A. Percent Retention System.....	49
B. Gas Supply System.....	51
C. Method of Analysis.....	51
D. Statistical Method.....	54
E. Choice and Care of Animals.....	56
F. Histological Method.....	56
II. Experimental Procedure.....	57
III. Observations.....	58
IV. Results.....	59
V. Histological Studies.....	73
VI. Discussion and Conclusions.....	75
BIBLIOGRAPHY.....	86

LIST OF TABLES

	<u>Page Number</u>
Table 1.1. The mean and standard deviation of various physiological parameters of groups of rats...	21
1.2. The t-test of significance of differences in the mean tidal volumes, initial and observed respiratory rates.....	22
1.3. Correlation between tidal volume, minute volume and body weight.....	23
Table 2.1. Efficiency of the absorber at different sulphur dioxide concentration levels.....	42
2.2. Effect of carbon dioxide on sulphur dioxide determination by the analyzer.....	42
Table 3.1. The values of mean percent retention (<i>a</i>) with standard deviations of groups of rats exposed to different concentrations of sulphur dioxide.....	61
3.2. Analysis of Variance and Duncan's Test of the relationship between concentrations of sulphur dioxide, duration of exposure and the value of percent retention.....	63
3.3. The values of mean respiratory rate with standard deviations of groups of rats exposed to different concentrations of sulphur dioxide.....	64
3.4. Analysis of Variance and Duncan's Test of the relationship between concentrations of sulphur dioxide, duration of exposure and respiratory rate.....	66
3.5. The values of mean tidal volume with standard deviations of groups of rats exposed to different concentrations of sulphur dioxide.....	67
3.6. Analysis of Variance and Duncan's Test of the relationship between concentrations of sulphur dioxide, duration of exposure and tidal volume.....	69

Table 3.7. The values of mean minute volume with standard deviations of groups of rats exposed to different concentrations of sulphur dioxide.....	70
3.8. Analysis of Variance and Duncan's Test of the relationship between concentrations of sulphur dioxide, duration of exposure and minute volume.....	72

LIST OF FIGURES

	<u>Page Number</u>
Figure 1.1. Schematic diagram of the electrical system.....	9
1.2. Block diagram of the tidal volume measurement system.....	11
1.3. Calibration curves for the sensing system.....	13
1.4. Rat in holding device.....	15
1.5. Typical respiratory patterns of rats in four different weight ranges. Recorded at chart speeds of 5 mm. and 50 mm. per second respectively.....	17
Figure 2.1. Schematic diagram of the analytical system.....	31
2.2. Photograph of the glass absorber and detector cell.....	32
2.3. Schematic diagram of the electrical system.....	34
2.4. The frequency-response curve for sulphur dioxide.....	36
2.5. Calibration curves for the analytical system.....	37
2.6. Rate of response of the analytical system.....	40
Figure 3.1. Photograph of the tap system.....	50
3.2. Photograph of the gas supply system.....	52
3.3(1). Typical respiratory patterns of rats exposed to 42 p.p.m. of sulphur dioxide..	55
3.3(2). Equivalent minute volume.....	55
3.3(3). Alterations of the concentrations of sulphur dioxide before and during inhalation exposure.....	55

Figure 3.4.	Effect of concentration of sulphur dioxide in inspired air on the retention by the respiratory system.....	62
3.5.	Effect of concentration of sulphur dioxide in inspired air on the respiratory rate.....	65
3.6.	Effect of concentration of sulphur dioxide in inspired air on the tidal volume.....	68
3.7.	Effect of concentration of sulphur dioxide in inspired air on the respiratory minute volume.....	71
3.8.	Photomicrograph (X125) of lung of a rat that survived 120 minutes of exposure to 426 p.p.m. of sulphur dioxide.....	74
3.9.	Photomicrograph (X125) of lung of a rat that died after 30 minutes of exposure to 751 p.p.m. of sulphur dioxide.....	74
3.10.	Percent retention of sulphur dioxide by rats during the first minute of inhalation exposure to various concentrations of the agent.....	76
3.11.	Exponential percent retention of sulphur dioxide by rats during the first minute inhalation exposure to various concentrations of the agent.....	76

CHAPTER ONE

**A NEW TECHNIQUE FOR TIDAL VOLUME MEASUREMENT IN
UNANAESTHETIZED SMALL ANIMALS**

PART I. LITERATURE SURVEY

I. Introduction.

In the critical evaluation of the effect of a gas or vapour on an animal, the use of the dosimetric method is recommended⁽¹⁾. This procedure requires the measurements of tidal volume, respiratory rate or minute volume of the test animal as well as a knowledge of the concentrations of gas or vapour in the inspired and expired air in order to calculate the dose of the agent being retained.

II. Review of Methods.

Various techniques for determining the required physiological parameters have been developed and can be classified into two categories.

A. Indirect Methods.

These procedures deduce the tidal volume through its relationships with parameters such as oxygen consumption, chamber barometric pressure, body electrical impedance or the applied electromagnetic field strength.

(1) Oxygen Consumption Method.

In this method, it is assumed that animals use up approximately 5 percent of oxygen from the air, as man does. The oxygen consumption in 24 hours in a small animal can therefore be estimated from the heat production and subsequently the average tidal volume of the animal over a period of 24 hours can be calculated from the observed metabolic rate^(2,3).

(ii) Electrical Impedance Spirometer.

The effect of respiratory motion on the capacity of a condenser in which the body acts either as one of the plates or as the dielectric was noted as early as 1937⁽⁴⁾. Recording of the respiratory function of both animals and man was achieved by measuring impedance changes between electrodes embedded in the subcutaneous tissue of the chest⁽⁵⁾. Recently, improvements have also been made in the technique by eliminating the interference of the cardiac action on the impedance and have permitted the separation of a relatively undistorted and accurate respiratory wave form⁽⁶⁾.

(iii) Magnetic Field Device.

This technique was originally developed for recording tremors in small animals⁽⁷⁾. It was later adopted for the studies of respiratory function in small mammals⁽⁸⁾. In experiments where anaesthetized animals were used, a small bar magnet was placed subcutaneously on the lateral-ventral side of the thorax and abdomen of the animal at an angle of about 30° off the long axis. For experiments using unanaesthetized mice the magnet was located so that a good apposition with the pick-up coil was obtained. The voltage output of the pick-up coil bore a direct relationship with the excursion of the respiratory movements and provided an estimate of the tidal volume of the experimental animal.

(iv) Barometric Method.

The chamber barometric method was based upon the assumption that the pressure in a closed chamber increased

when heat and moisture were added to the system from each expiratory tidal air of the experimental animal. Furthermore, both the pressure and the temperature effects are equilibrated to pre-existing conditions after each expiration and before another inspiration. Consequently, the observed chamber pressure variations would be the measures of the ventilation of the animal (9).

(v) Body Plethysmograph Techniques.

The plethysmograph consisted essentially of a glass or plastic cylinder in which the animal would sit comfortably enough to remain quiet. An airtight seal around the neck was achieved by the use of rubber dam or inflatable cuffs together with collodion or certain resins. As the animal breathes, the pressure variation within the system was detected by means of a sensitive pressure transducer (10,11) or inductive, electro-mechanical transducer (12,13). The magnitude of the generated signal is usually directly proportional to that of the tidal volume. Consequently an estimate of the respiratory ventilation of the experimental animal may be obtained.

B. Direct Methods.

These procedures estimate the tidal volume and respiratory rate either by direct measurement of the volume of gas respired or by the changes of pressure in the air-supplying system due to the variation of the respiratory air-flow pattern of the animal.

(1) Valve Methods.

This technique has been perhaps the most frequently

used procedure. The apparatus consisted essentially of a low resistance one-way valve system delicately constructed with thin rubber or plastic discs or glass beads resting over the tips of polished inlet and outlet tubes. The valve system was then connected directly to a tight-fitting head piece, a face-mask or tracheal cannulation. The amount of air respired per unit time was measured directly by means of some type of gas volume measuring device such as a spirometer or water displacement arrangement or soap-film flow meter (6,14,15,16).

(ii) Respirograph Methods.

The measurement of the tidal volume was accomplished by allowing the experimental animal to breathe into a closed tube with a rubber diaphragm sealing the distal end. A small mirror was attached to the diaphragm and reflected a beam of light onto a moving film strip. The excursion of the beam was calibrated to allow the estimation of tidal volume while the respiratory rate was also recorded simultaneously (17,18).

(iii) Air-flow Methods.

A notable advance was made when a closed system, valveless, air-flow respirographic technique was introduced (15). The apparatus consisted of a closed air supply circuit in which air was passed through the head piece at a rate such that the volume was at least five times as great as that required for the normal respiration of the animal. This arrangement provided fresh air at all times and the animal breathed against a negligible resistance which was many times less than that

caused by the valves. A third tube led from the head piece to a pressure sensitive electrical condenser. Variation in the electrical capacity of the condenser was calibrated for the estimation of the tidal volume.

III. Comments on Various Techniques.

In the first category of methods, the oxygen consumption method is obviously difficult to apply simultaneously with inhalation studies. The removal of expired carbon dioxide together with the possible alteration of the pulmonary function of the animal by toxic gases or vapours may cause problems in the accurate determination of the various respiratory parameters. Other methods such as the impedance spirometer and the magnetic device may involve anaesthesia or surgical procedures. The plethysmographic technique, on the other hand, imposes a severe restraint on the animal and provides a tracing of the sum of the thoracic and abdominal components of the respiratory movements rather than the actual air-flow pattern of the respiratory system. The barometric technique, together with some of the above methods, requires that considerable attention be paid to temperature regulation. Finally, the recordings of the respiratory movements of the animal in most of the procedures suffer from interference due to adverse body movements caused by struggling.

In the second category, the valve method necessitates the use of tight-fitting face-mask or tracheal cannulation. In addition the test animals have to breathe against considerable resistance in order to operate the one-way valve system and the attached gas volume measuring devices. The air-flow methods, on the other hand, have a limited air supply and requires that the animal be subjected to considerable restraint.

IV. Objective of Present Studies.

The objective of the present studies is to develop a method for the continuous and simultaneous determination of tidal volume, respiratory rate, minute volume and air-flow pattern of rats under normal, physiological conditions. A new method must overcome the limitations of earlier techniques and possess the following requirements:

- (1) The system should permit the determination of the respiratory parameters of small animals continuously over a period of several hours.
- (2) There should be no resistance of any kind within the system that may affect the normal respiratory function of the animal.
- (3) The pressure sensing system should respond almost instantaneously with no appreciable lag or inertia.
- (4) The response should be as nearly linear as possible and should be accurate to within 5%.
- (5) The apparatus should be readily adaptable for direct recording.
- (6) Small changes in environmental temperature not exceeding $\pm 3^{\circ}\text{C}$, and normal variation in atmospheric humidity should have no significant effect on its functioning.

With the above requirements in mind, a unique, open-circuit, valveless, air-flow respirographic technique has been developed.

PART II. EXPERIMENTAL RESEARCH

I. Materials and Methods.

A. Electrical System.

The electrical system (Fig. 1.1) employed in this technique consisted essentially of a Wheatstone Bridge Circuit. Two of the arms were shared by the electromagnetic transducer section. The transducer (Northram DP7), which has a frequency response of 250 c.p.s., was energized by 7.5 volts from a beat frequency audio generator (General Radio Model 1304B) at 2000 c.p.s. The output voltage of the oscillator was monitored by a commercial voltmeter (Fisher Recordall). The other two arms of the bridge were occupied by a standard 10,000 ohm resistor and a bank of decade resistors (General Radio) respectively. The bridge was balanced to 0.01% of the ratio arm load by adjusting the resistance and capacitance. It was then offset 50 millivolts at the oscillograph (Grass Polygraph) and finally rebalanced to null by a 0.2% change in pure resistance at the bridge level. Thus, any variation in pressure between the mask and the main air tube would cause the developed voltage to add or subtract from this 50 millivolt offset. However, this A.C. signal had to be amplified before detection. A special three-stage cathode follower with high stability with regard to phase shift and amplification was therefore designed. This amplifier changed the impedance of the A.C. voltage from a high level to a low level in each of the first two stages and then amplified the voltage in the interstage audio transformer (Hammond 800 series). This device was peaked at 2,000 c.p.s. and

drew only 10 milliamperes from the highly filtered, regulated power supply of 200 volts having a 60-cycle content of 20 microvolts. The amplified signal was then rectified by a diode (IN34) and passed into a suitable resistance impedance network filter, having an attenuation of 50 db., to match the amplifier and the oscillograph. From the oscillograph a recording of pressure variation on a time base was obtained. The area circumscribed by the pressure curve and the baseline may be used to provide an estimate of the tidal volume. Simultaneously, voltages were drawn from the oscillograph to be rectified and summated on a time base of 4 seconds. The total voltage output was read numerically on a microvoltmeter (Millivac MB27D) and recorded on a time base on a DC millivolt recorder (Varian). The magnitude of this summated voltage furnished an estimate of the volume of air delivered in 4 seconds and hence the equivalent minute volume, as will be discussed below in the section on calibration. Finally, the frequency response of the system as a whole was determined by the step function technique (13) and found to be better than 40 cycles per second at the upper limit whereas the lower limit was essentially zero. Consequently a pulse contour detail up to the 15th harmonic of the respiratory rate of a normal rat could easily be obtained.

Fig. 1.1. Schematic diagram of the electrical system.

E. 2000 c.p.s. source.

T. Transducer.

I. Integrator.

O. Oscillograph.

B. Offset voltage.

V. Microvolt meter.

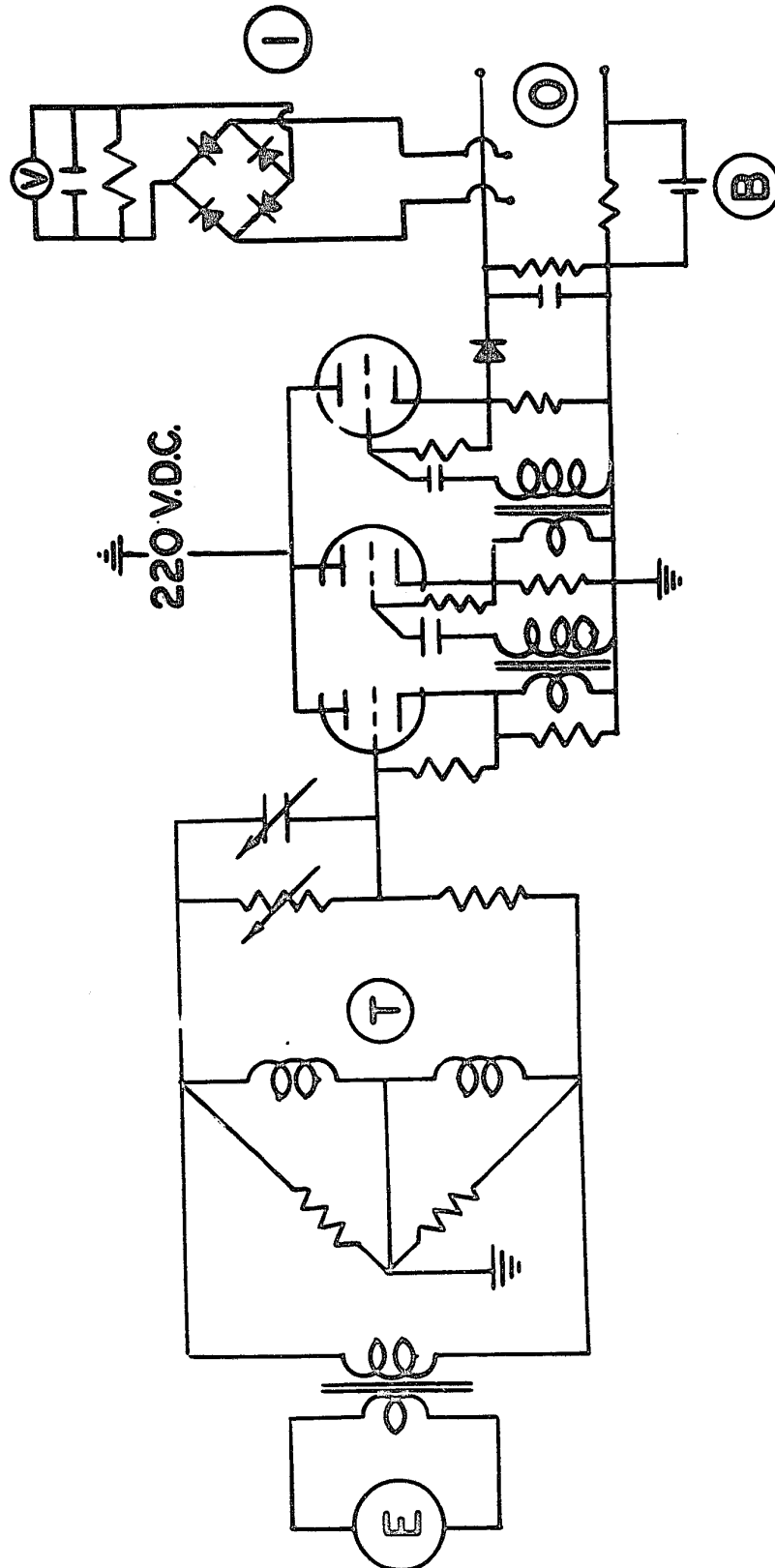

Fig. 1.1

B. Tidal Volume Measurement System.

The system (Fig. 1.2) consisted of a gas supplying tube, A, being fed at a constant air flow of approximately 400 ml. per minute from a compressed source. This volume of air is approximately 1.5-2 times as great as the normal respiratory requirements of a 200-300 gm. rat. A second tube, B, located opposite to the outlet of the face-mask attachment tube, C, led to the sensitive pressure transducer for sensing the minute pressure changes produced in this open-circuit system by the inspiration and expiration of the rat. The length of this tube, B, was found to be not critical and could vary from a fraction of an inch to several inches without affecting the measurement of the changes in pressure. On the other hand, it was observed that maximal response from the pressure transducer was only obtained when a slight resistance to air-flow was introduced on the discharge side of the air line. A 10-inch length of plastic tubing, D, having an inside diameter of 0.125 inch provided a suitable resistance for this purpose. Under these conditions, the building of pressure within the face mask E, was found to be practically nil (0.3 mm. of water).

Fig. 1.2. Block diagram of the tidal volume measurement system.

- A. Gas supplying tube.
- B. Transducer connecting tube.
- C. Face-mask attachment tube.
- D. Discharge side of air line.
- E. Face-mask.

- 1. Transducer.
- 2. Oscillator.
- 3. Voltmeter.
- 4. Bridge.
- 5. Amplifier.
- 6. Power supply.
- 7. Filter.
- 8. Oscillograph.
- 9. Integrator.
- 10. Microvoltmeter.
- 11. DC Millivolt Recorder.

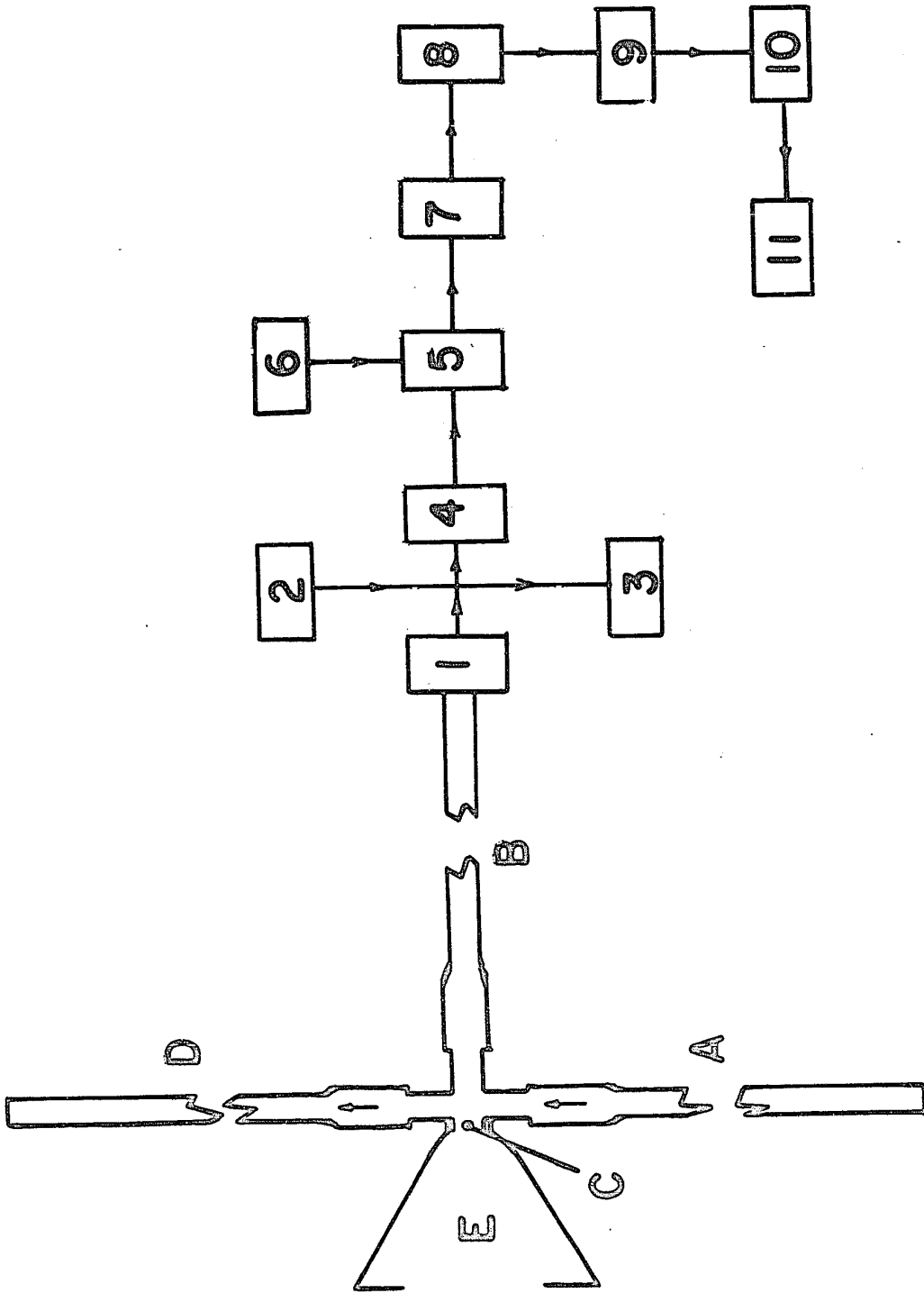

Fig. 1.2

C. Calibration.

The response of the transducer in the open-circuit tidal volume measurement system was calibrated by coupling a syringe onto the face-mask attachment tube. The plunger of the syringe was connected to a rotational-to-horizontal reciprocating motion translator which produced simple harmonic motion simulating the normal respiratory pattern of mammals. This mechanical system was driven by a variable speed motor having a frequency range from 30 to 180 strokes per minute and was capable of providing a stroke volume variable from 0.5 to 2.5 ml. By adjusting the stroke volume and frequency, the volume output per minute could be adjusted over the range from 40 ml. to 380 ml., corresponding to the range of interest when determining the minute volume of rats. The calibration curves (Fig. 1.3) were constructed by plotting the calculated volume of air delivered per minute against the voltage output as observed in the DC millivolt recorder at four different sensitivities in the oscillograph level. As will be seen from Fig. 1.3, the response is linear for volume outputs of 40 to 90, 90 to 175, 175 to 260 and 260 to 380 ml. per minute, at the decreasing sensitivities 2, 5, 10 and 20 mv./cm., respectively. It was found that, for any given stroke volume, regardless of the rate at which it was discharged, the developed voltage was constant. This formed the basis for relating the observed developed voltage produced by the air movements from a rat under test to volume output per minute as determined from the calibration curves. The day-to-day variations in response of the whole system in measuring a given stroke volume of

Fig. 1.3. Calibration curves for the sensing system.

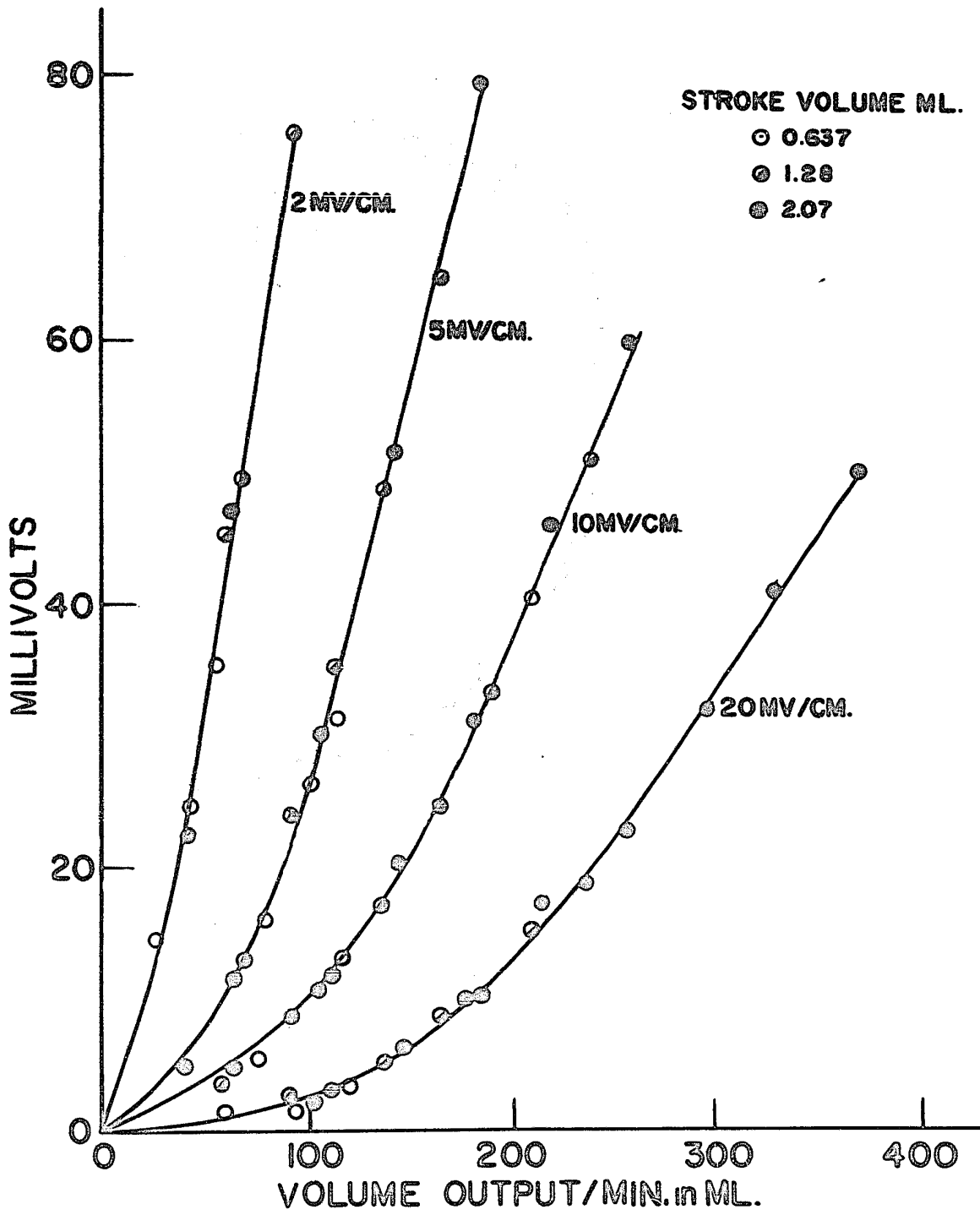

Fig. 1.3

air was found to be within 4%. However, frequent recalibration of the system at the beginning of each experiment reduced the variations in volume measurement to less than 1%.

D. Animal Holding Device.

The body of the rat was inserted in a tubular plastic tube holder (Fig. 1.4). A collar and a face-mask were mounted on the front of the cage in such a manner that each could be adjusted fore and aft, up and down, and at any inclination. The face-mask was machined from plastic into the form of a cone which closely fitted the muzzle of the rat. A reasonably leak-proof air-seal was achieved by use of a ring of rubber dental dam. The face-mask was coupled perpendicularly onto the main gas tube of the tidal volume measuring system. In addition, an opening was located on top of the cage permitting the administration of subcutaneous injections, while the head and tail of the animal in the holder were available for other experimental procedures.

E. Choice of Animals.

Male rats of the Wistar strain were selected. The animals were divided into four groups of ten and were in the restricted weight ranges 50-60 gm., 100-120 gm., 200-220 gm., and 290-310 gm., corresponding to approximately 5, 7, 10 and 18 weeks of age respectively.

II. Experimental Procedures.

At the beginning of each tidal volume measurement, the rat was placed in an individual cage. The average respiratory rate of the animal at resting condition was determined with a stopwatch. The rat was then transferred into the holder in which it was permitted

Fig. 2. Rat in holding device.



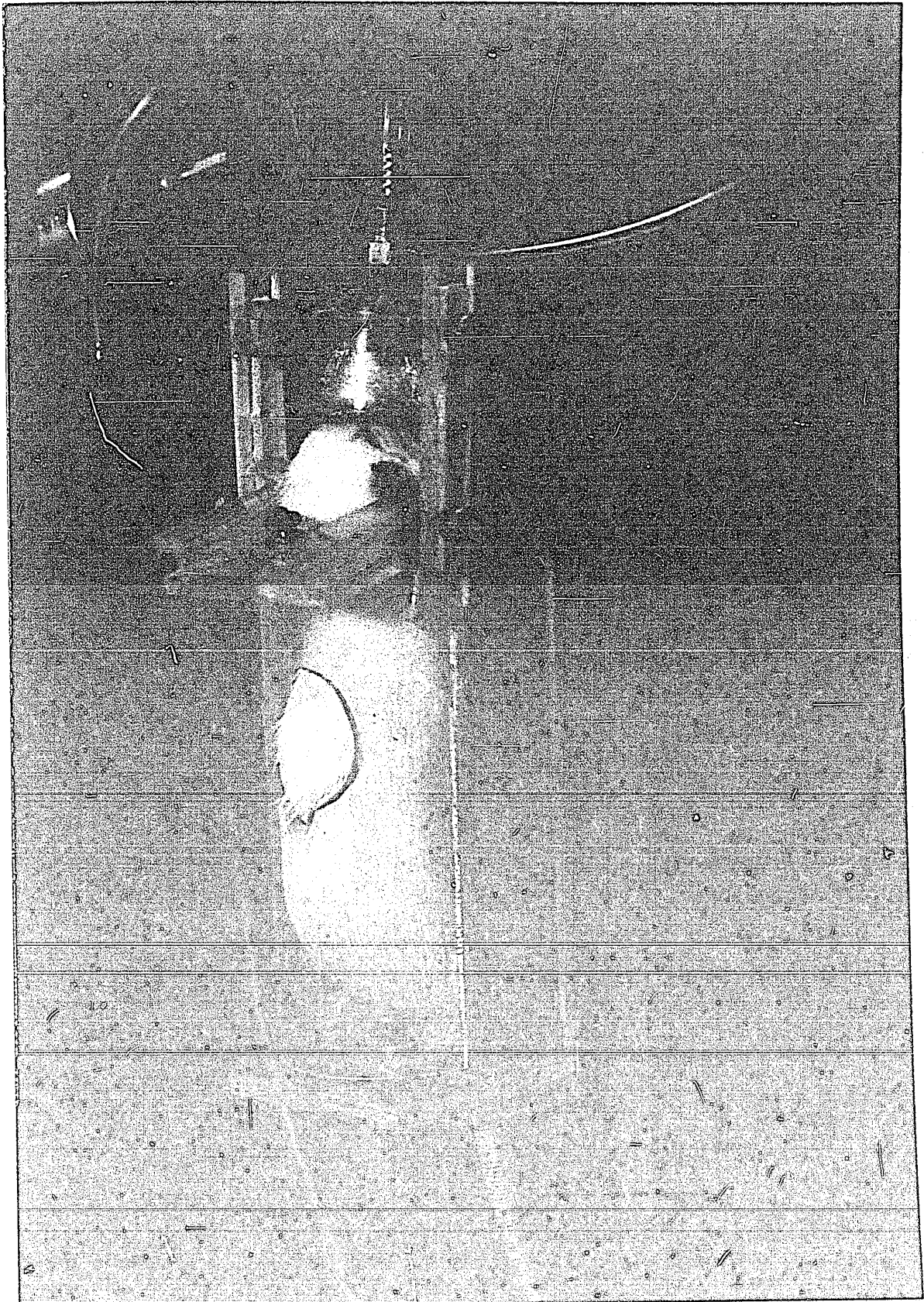
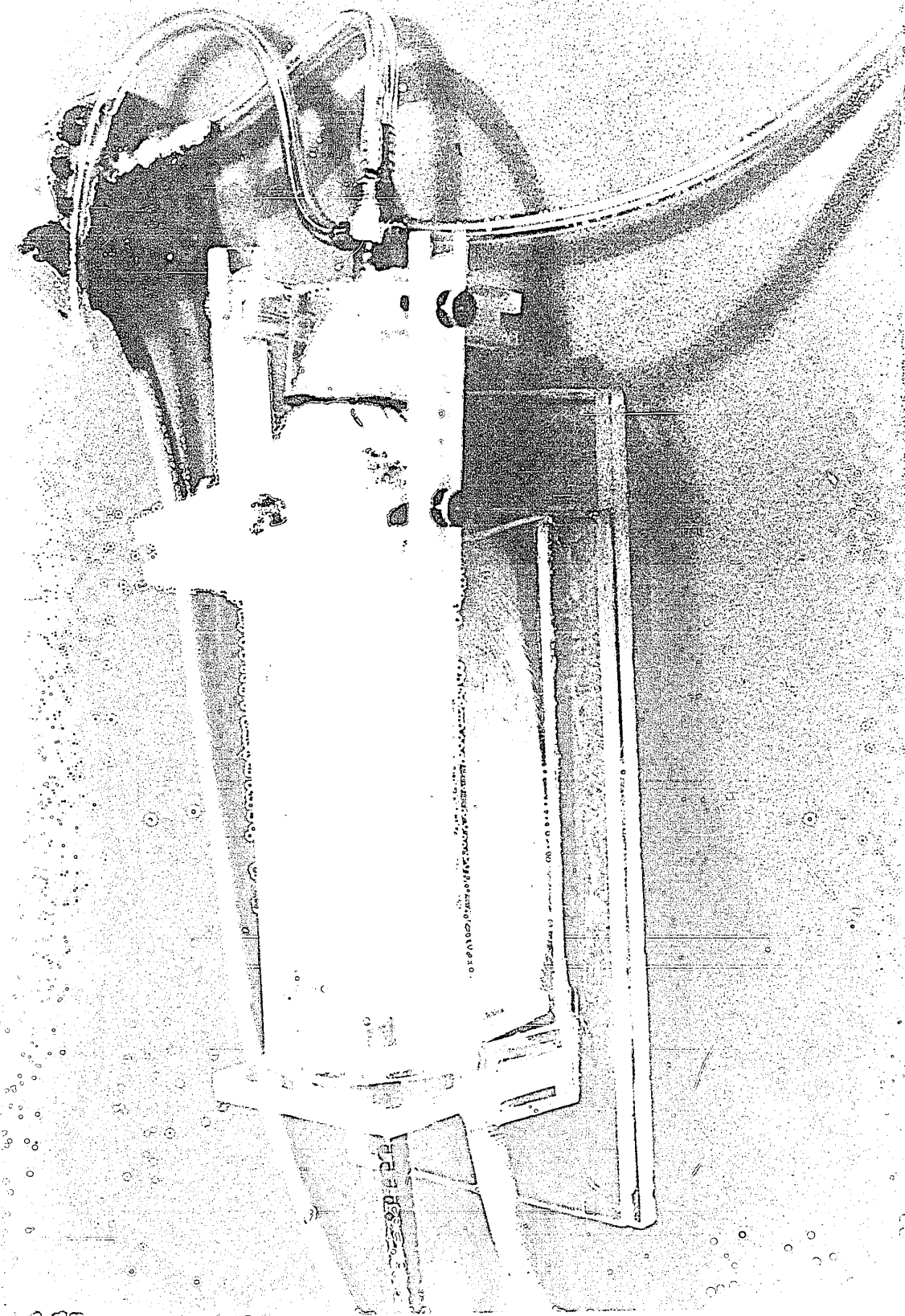

Fig. 1.4



to rest comfortably after proper adjustment of the collar piece and face-mask. The gas supply tube of the tidal volume measurement system was then coupled onto the mask. When the animal settled quietly and breathed evenly within a narrow margin of rhythmic variation, recording of the respiratory function began. The chart speed of the direct-writing oscillograph was set at 5 mm. per second for recording the respiratory rate and 50 mm. per second for detailed recording of the air-flow pattern of the respiration of the animal. The tidal volume of the animal at any period was computed by dividing the observed minute volume by the corresponding respiratory rate. The air-flow pattern (Fig. 1.5) could also be analyzed in terms of the relationship between respiratory air-flow and time.

III. Results.

The ventilatory data obtained from the four groups of ten animals are presented in Table 1.1.

The values in the table indicate explicitly that the mean tidal volume and minute volume become higher as the body weight of the animals increase whereas the respiratory rates remain approximately the same. The t-test for significance of the difference between the means of tidal volume, and among the initial and observed respiratory rates was performed. The t-values obtained for the various comparisons are entered in the last column in Table 1.1 and in Table 1.2.

The comparisons show that the mean tidal volume for 298.5 gm. (A), 211.3 gm. (B), 109.8 gm. (C) and 52.3 gm. (D) groups are significantly different from one another. The mean respiratory rates of the smaller animals are also significantly higher than those of the larger animals.

Fig. 1.5. Typical respiratory patterns of rats in four different weight ranges: 298.5 gm. (A), 211.3 gm. (B), 109.8 gm. (C) and 52.3 gm. (D). Recorded at chart speeds of 5 mm. (first section) and 50 mm. (second section) per second respectively.

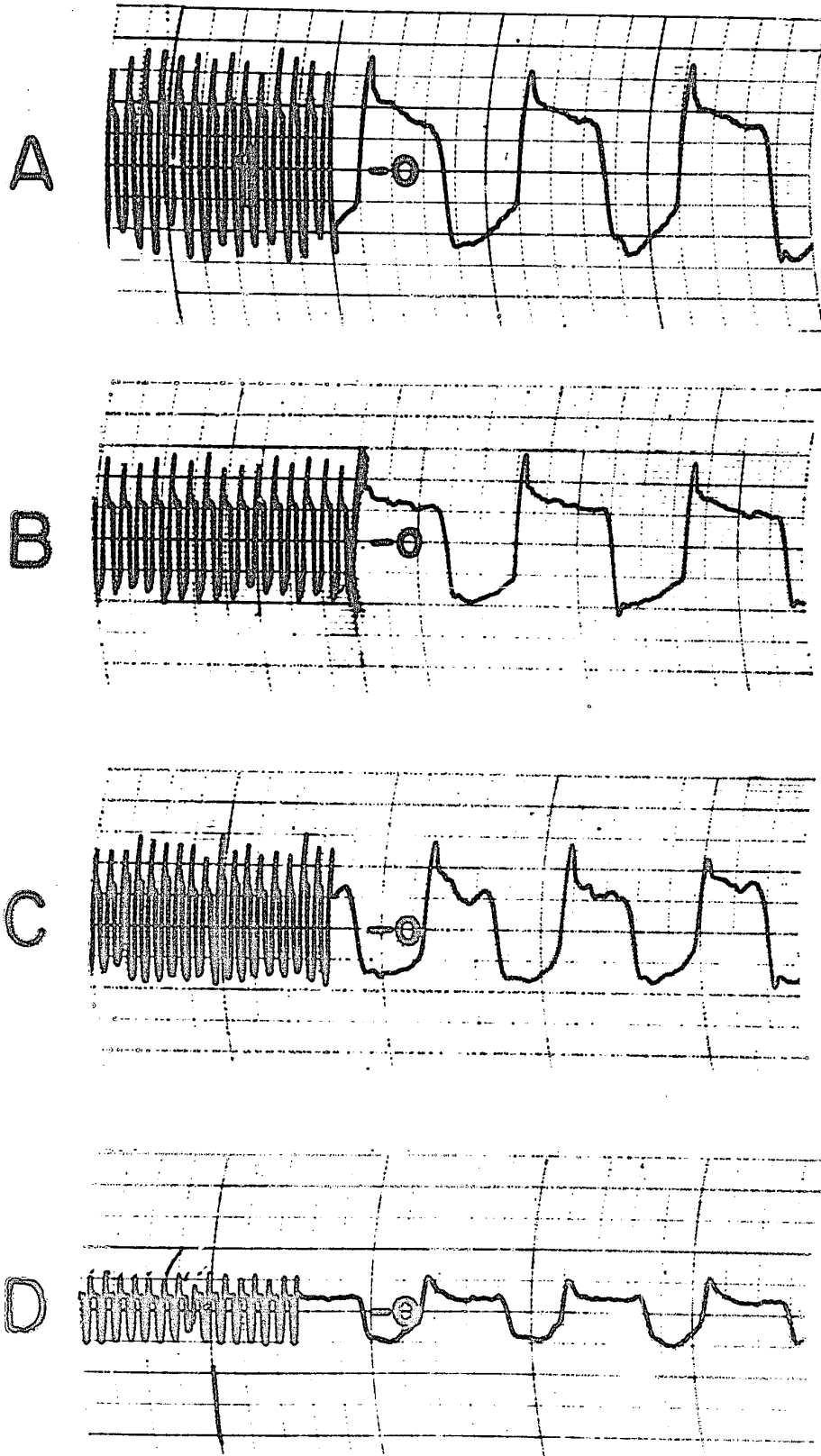

Fig. 1.5

However, the initial and observed respiratory rates within these small animal groups do not differ significantly. (See Table 1.1). Similarly there is no significant difference between the initial respiratory rates of the 52.3 gm. and 109.8 gm. groups. Furthermore, there is no significant difference in respiratory rates among all three larger animal groups.

IV. Discussion and Conclusions.

The versatility of this new technique and instrumentation for the determination of the respiratory volume of small animals is well demonstrated by the data presented. This open-circuit, valveless, continuous air-flow respirographic technique is unique in that animals tested under such experimental conditions approach normal physiological conditions more nearly than in any other methods. The animal could breathe a constant supply of air or a mixture of gases in certain pharmacological or toxicological studies. The dead space within the face-mask is practically nil and consequently causes no errors or complications in densitometric studies. In addition, the animal breathes against no resistance and thus an inherent difficulty in most of the direct methods, especially in the valve methods, is avoided. Furthermore, the virtual absence of back-pressure within the mask eliminates the need for a perfectly air-tight seal around the muzzle of the animal. Consequently, the experimental animal is subjected to less restraint. The whole experimental system permits the simultaneous, continuous and direct determination of the tidal volume, minute volume, respiratory rate and air-flow pattern over a period of several hours if necessary.

The ability of the instrument to faithfully reproduce respiratory parameters is revealed by its performance in differentiating the minute variations in tidal volumes in small animals of different weight ranges.

It is interesting to observe that the mean respiratory rate for the youngest animal group was significantly higher than that of the older animal groups whereas there was no significant difference in respiratory rate among rats heavier than 100 grams. Although it is generally recognized that there is an inverse relationship between resting respiratory frequency and body size⁽¹⁴⁾, the limited amount of data derived from the study of so few animals is insufficient to establish this relationship within this one species.

The correlation between tidal volume, minute volume and body weight at various mathematical functions have been re-examined. The results are shown in Table 1.3. The tidal volume divided by the weight of the animal shows a decline in value as the animal becomes larger. However, when the tidal volume is divided by the 0.67 power of their weight, the values remain more constant. Since the surface area of mammals is proportional to the 0.67 power of their weight⁽¹⁵⁾, the tidal volume may therefore be considered to vary closely with the body surface in these experiments rather than with the body weight⁽¹⁶⁾. On the other hand, the ventilation varies accordingly to the 0.73 power of the body weight. The ventilation of lungs in infant rats were found to be 1.27, 1.43 and 1.48 ml./gm. min. for rats having an age of 1-3, 6-9 and 16-26 days respectively⁽³⁾. Combining this data with our findings (Table 1.3, column 5), it is noted that the ventilation of the lung reaches a peak at the age of 4-5 weeks,

corresponding to the period of most rapid growth in the rat. The ventilation then declines to about 50% of that value when rats reach maturity and remains almost constant thereafter.

It is also interesting to note that the ratio between lung weight and body weight in rats follows a similar trend⁽¹⁷⁾. Based upon this finding, the lung weights of the animals used in this study have been estimated, and the tidal volume was found to vary approximately as the 0.75 power of the estimated lung weight. Determination of the exact relationship, however, requires further investigation.

Table 1.1. The mean and standard deviation of various physiological parameters of groups of rats

No. of Animals	Body Wt. (gm.)	Tidal Vol. (ml.)	Minute Volume (ml./min.)	(IR) Initial Resp. Rate (Resp./min.)	(CR) Observed Resp. Rate (Resp./min.)	t-tests between IR and CR
10	298.5 ± 7.6	1.84 ± 0.21	224.9 ± 27.9	113.7 ± 10.9	121.4 ± 7.7	1.82 [*]
10	211.3 ± 6.7	1.46 ± 0.19	161.5 ± 41.7	106.5 ± 12.1	110.2 ± 22.5	6.459 [*]
10	109.8 ± 5.1	0.98 ± 0.14	112.9 ± 16.6	115.6 ± 16.5	116.1 ± 12.6	0.076 [*]
10	52.3 ± 1.3	0.62 ± 0.04	86.9 ± 9.1	128.0 ± 13.8	139.3 ± 15.8	1.70 [*]

* significant at 98% level of probability.
 - not significant at 95% level of probability.

Table 1.2. The t-test of significance of differences in the mean tidal volumes, initial and observed respiratory rates.

Comparisons (Groups as indicated by weight range)	Tidal Volume (ml.)	Initial Resp. Rate	Observed Resp. Rate
298.5 vs. 211.3	4.71**	1.39 ^o	2.71 ^o
" vs. 109.8		0.31 ^o	1.13 ^o
" vs. 52.3		2.57*	3.22**
211.3 vs. 109.8	7.41*	1.41 ^o	1.14 ^o
" vs. 52.3		3.72**	3.35**
109.8 vs. 52.3	7.77**	1.82 ^o	3.62**

Degrees of freedom = 18
^o = not significant at 95% level of probability.
^{*} = significant " " 98%
^{**} = significant " " 99%

Table 1.3. Correlation between tidal volume, minute volume and body weight.

Approximate Age of Animals	Mean Body Wt. (gm.)	Tidal Vol./ Body Weight (ml./gm.)	Tidal Vol./ Body Weight (0.67)	Ventilation	
				Minute Vol./ Body Weight (ml./gm. min.)	Minute Vol. (0.73)
4-5 wks.	52.3 ± 1.3	0.0174	0.0437	1.62	4.84
6-7 wks.	109.8 ± 5.1	0.0089	0.0422	1.03	3.67
9-10 wks.	211.3 ± 6.7	0.0031	0.0414	0.763	3.25
16-18 wks.	298.5 ± 7.6	0.0006	0.0413	0.754	3.51

CHAPTER TWO

A NEW ANALYTICAL TECHNIQUE

FOR

SULPHUR DIOXIDE IN AIR

CHAPTER TWO

A NEW ANALYTICAL TECHNIQUE

FOR

SULPHUR DIOXIDE IN AIR

PART I. LITERATURE SURVEY

I. Introduction.

Sulphur dioxide is one of the most important irritant gases contributing to atmospheric pollution in large cities and industrial districts. Various wet chemical procedures or instrumental detectors have been developed for determining the concentration of this contaminant in air.

II. Review of Methods.

The various analytical methods employed are based on the reducing properties and acidic nature of the gas or the acidic character of its oxidation product.

A. Wet Chemical Methods.

The analytical procedures consist generally of trapping a known volume of gas sample in a given quantity of aqueous absorbent of certain chemical composition. Depending on the nature of the absorbent and the subsequent chemical reaction, the resultant solutions are analysed with appropriate reagents or certain physical means in order to determine the concentration of sulphur dioxide.

(1) Iodimetric Methods.

This chemical reaction was the earliest one employed for analysis of sulphur dioxide in air pollution surveys⁽²⁴⁾.

Sulphur dioxide in the gas sample was absorbed and oxidised by a standard iodine solution. The amount of iodine which had been consumed was determined by means of back titration with standardized thiosulphate solution. Starch solution was used as indicator. The equivalent quantity of sulphur dioxide could thus be calculated. Because of the volatility of the

iodine solution, various modifications of this absorbent were made by adding stabiliser such as iodide solution⁽²⁵⁾, or by totally replacing iodine solution with potassium permanganate solution⁽²⁶⁾.

(ii) Acidimetric Methods.

In this technique, sulphur dioxide was trapped in distilled water or alkali solution containing one of the many stabilisers such as stannous chloride^(27,28), benzyl alcohol⁽²⁹⁾, glycerol⁽³⁰⁾ or isopropyl alcohol⁽³¹⁾. Hydrogen peroxide was perhaps the most commonly used absorbent and sulphuric acid was the final product. These acidic or sulphate solutions were titrated with standardized alkali or analyzed by other physical means.

(iii) Colorimetric Methods.

Most of the previously described procedures can be used in conjunction with colorimetric or spectrophotometric techniques. Colour reagents such as the blue starch iodine-iodide solution can be reduced by sulphur dioxide to colourless solutions^(32,33). On the other hand, reagents such as the different types of basic fuchsin-formaldehyde dye solutions^(34,35,36) or sodium tetrachloromercurate⁽³⁷⁾ would produce colour in presence of the gas. The change in colour density was dependent on the concentration of the gas and the transmittance of light of certain wave length in these solutions was determined photoelectrically.

(iv) Conductometric Method.

This electrochemical technique has been perhaps the most frequently employed procedure for the determination of atmospheric sulphur dioxide. The contaminated gas sample was allowed to react with standard hydrogen peroxide solution to form sulphuric acid. The electrical conductivity of the solution bore a direct relationship with the hydrogen ion concentration and thus provided an estimate of sulphur dioxide concentration in the gas sample (38,39,40,41).

B. Automatic Instruments.

Various automatic and continuous analytical instruments based upon different chemical or electrochemical principles have been developed for the determination of sulphur dioxide in air.

(i) Semi-Automatic Analyzers.

Earlier semi-automatic instruments were usually based on iodimetric reactions. These devices consisted essentially of a cam-operated poppet valve system which permitted alternately the sampling of air and the discharging of the final solution from the absorber (42). Others employed a motor-driven impinger unit to serve a similar purpose (43). The discharged absorbent solutions were then titrated manually with appropriate reagents in order to obtain the equivalent concentration of sulphur dioxide.

(ii) Automatic Analyzers.

These semi-automatic devices were rendered completely automatic when they were modified for colorimetric or

conductometric procedures and employed in conjunction with suitable continuous recording potentiometers.

The automatic, continuous colorimetric analytical techniques which involved the colour reactions of starch-iodine solution^(44,45,46) or different types of fuchsin dyes^(47,48), and some of the conductometric procedures^(49,50,51) belonged to the "accumulating" type. This type of analyzer operated by drawing a steady air stream through a measured volume of absorbing solution for a definite period. At the end of the designated interval, the solution was discharged and replaced with a fresh solution. The change in transmittance or conductivity of the solution was detected continuously by means of a photoelectric cell or a potentiometer. The tracing produced by the recorder were saw-toothed in appearance and showed the total change of transmittance or conductivity during each sampling period of 30 minutes, and the average sulphur dioxide concentration for that interval of time. The "instantaneous" type of conductometric analyzers consisted of various types of counter current absorbers. The conductivity of the effluent was continuously measured and the record represented a 1-2 minute average concentration of the gas^(46,52,53,54). Finally, the recently developed automatic, continuous coulometric titration^(55,56,57) could also be included in this category. The principle of operation is based upon the oxidation of sulphur dioxide in the incoming gas stream by the electrically-generated bromine in the coulometric

cell. The magnitude of the electric current required for the production of an equivalent amount of bromine is recorded continuously and indicates the change in sulphur dioxide concentration.

III. Comments on Various Techniques.

All of the described procedures suffer from the disadvantage of requiring a relatively large volume of gas for analysis. In case of the colorimetric methods, the average sampling rate of gas is approximately 250 ml. per minute. That of the conductometric technique may be as high as 12-15 litres per minute and that of the coulometric is around 100 ml. per minute. Furthermore, the recordings from the colorimetric and conductometric techniques are primarily the average value of short intervals (20-30 minutes) rather than measures of the continuous changes in gas concentration. In the coulometric method, the continuous recording is merely the net titration level and the actual concentration of the gas is obtained only by multiplying the observed value by an instrumental factor which must be separately determined under identical experimental conditions.

IV. Objective of Present Studies.

The objective of the present studies is the development of a sulphur dioxide analytical method which can be adapted to certain toxicological investigations such as dosimetric inhalation studies. This procedure requires a chemical analytical system which will permit detection of the difference in concentration of the agent in the inspired and expired air of an animal. It is also considered desirable to record this difference continuously and instantaneously. The

shortcomings of the described techniques, when considered in relation to the present problem, precludes their use.

PART II. EXPERIMENTAL RESEARCH

I. Materials and Methods.

A. Analytical System.

The arrangement of the analytical system is shown schematically in Fig. 2.1. Air containing sulphur dioxide is drawn through the absorber by means of the syphon bottle arrangement. The rate of flow is regulated to 35 ml. per minute with the aid of a Teflon^R needle valve and a rotameter. Absorbent solution ($4 \times 10^{-3}M H_2O_2$, $5 \times 10^{-5}M H_2SO_4$) is fed by gravity and regulated also by a Teflon^R needle valve to flow at the rate of 5 ml. per minute into the absorber. A constant pressure head is maintained by continuously pumping the electrolyte to the over-flow constant head pressure device. In the absorber, the solution reacts with sulphur dioxide from the air and then drains down the capillary side tube into the detector cell where the impedance of the electrolyte is detected. Fig. 2.2 is a photograph of the glass absorber and the detector cell which are built into one unit. This counter-current absorber has a gas capacity of approximately 5 ml. A medium coarse fritted finger, which is prepared so that the absorbent solution oozes slowly from the side only, is ring-sealed within the cylindrical body. This arrangement provides a very efficient absorptive surface of approximately 9.5 square centimeters in area. Air enters the absorber through the lower side, flows against the down-dripping absorbent and leaves through the upper orit on the opposite side. The reacted solution is then drained through the bottom capillary tube to the detector portion of the cell. This bottom capillary

Fig. 2.1. Schematic diagram of the analytical system.

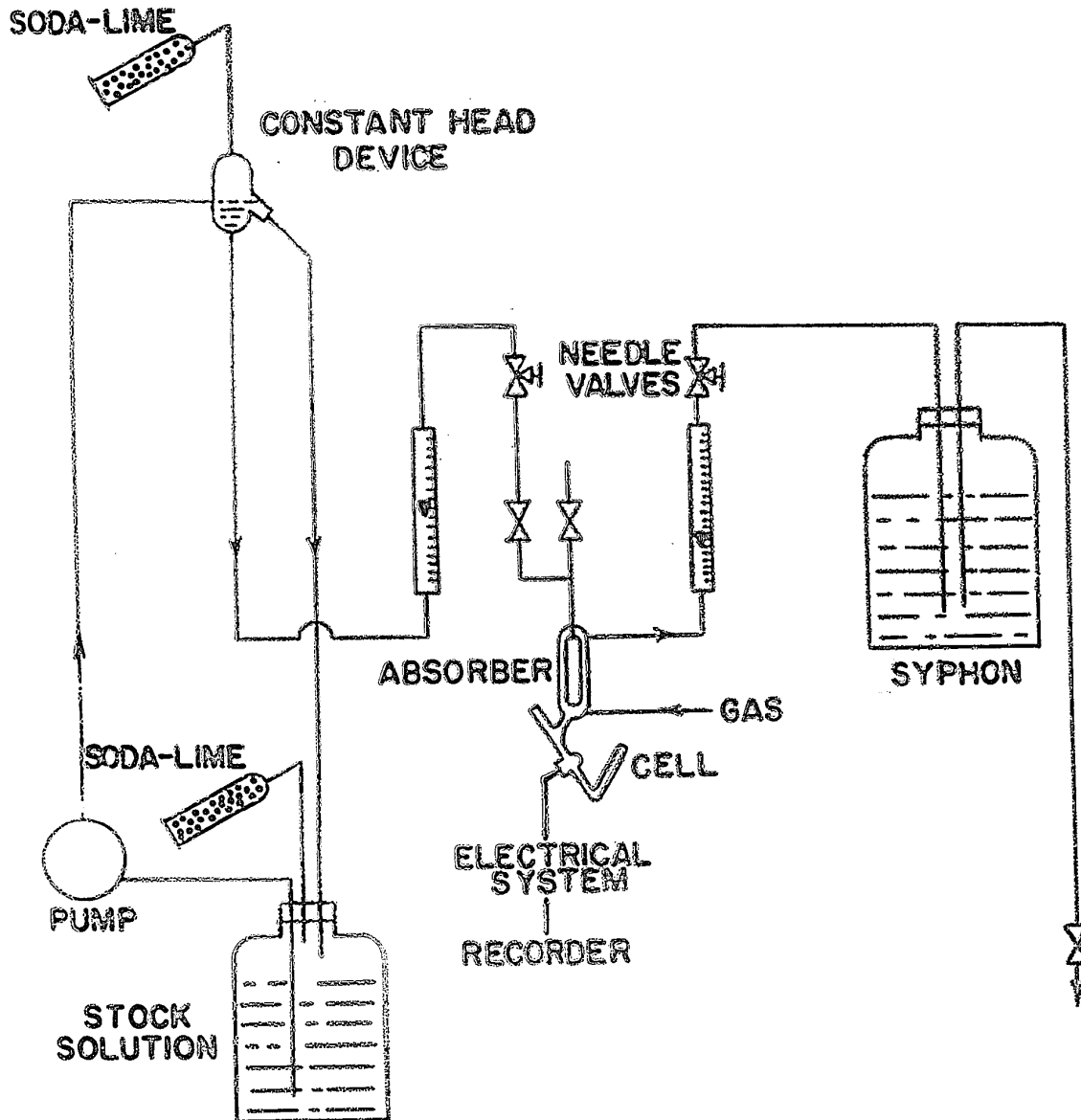

Fig. 2.1

Fig. 2.2. Photograph of the glass absorber and detector cell.

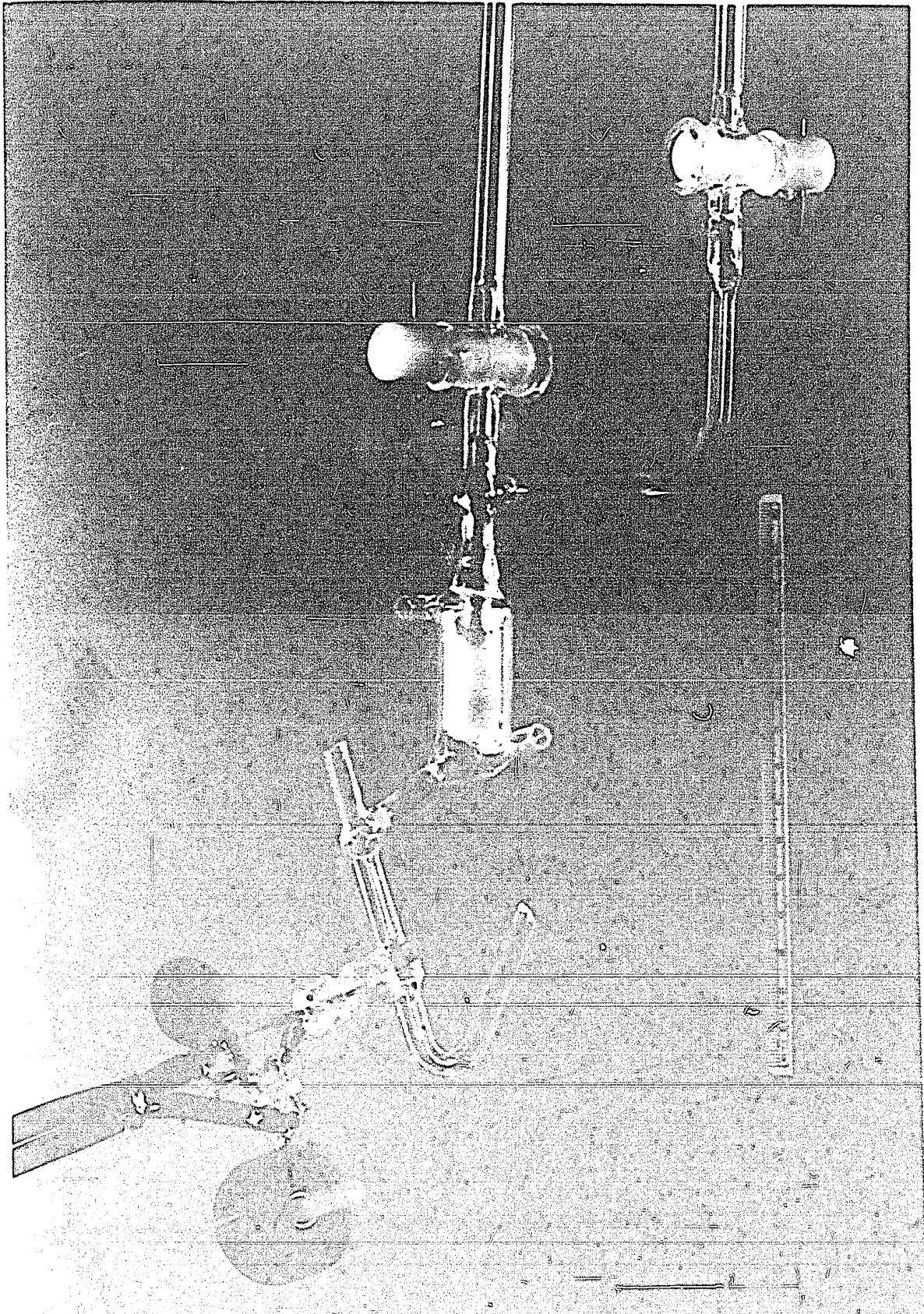
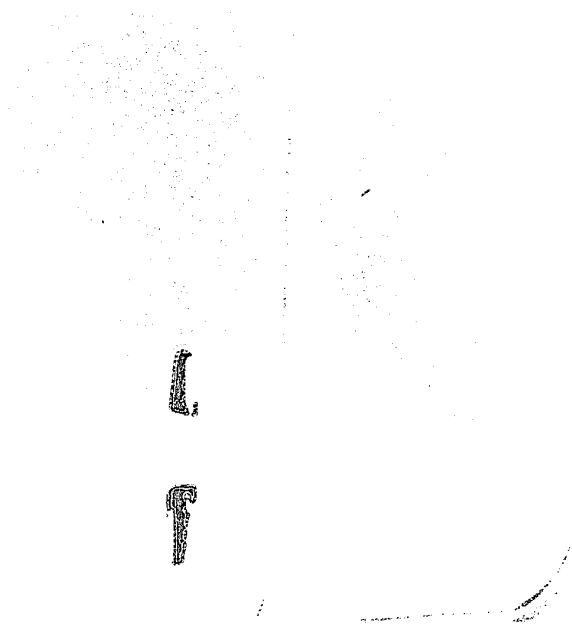
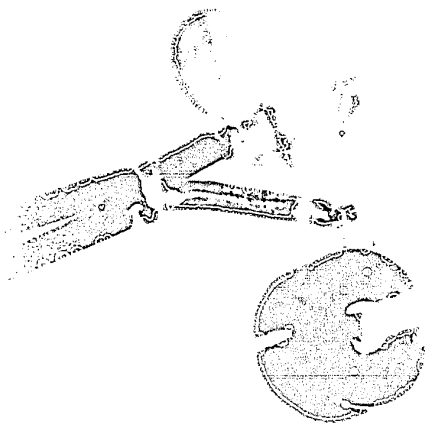

Fig. 2.2



tube serves not only as drain tube but also as the external air seal and pressure equalizing vent. The effluent flows continuously by gravity through the V-shaped detector section where, at any moment, a constant volume of effluent is held. The changes in impedance of the solution are detected by two parallel platinum electrodes (0.25" long, 0.040" diameter) mounted 0.25" apart through a plastic plug at the bulb-like portion of the capillary tube.

8. Electrical System.

The electrical system employed in this sulphur dioxide analytical instrument is essentially a comparison circuit (Fig. 2.3) in which the developed voltage from the detector cell is continuously compared with a pre-determined reference voltage. The primary voltage is generated by a standard power supply employing full-wave rectification, capacity resistance filtering and mercury voltage regulation techniques. It is then reduced by series resistance to 0.25 volts in the reference side of the circuit. This magnitude of voltage has been selected after performing a series of power dissipation efficiency tests on the absorbent electrolyte, and was found to provide a very stable and favorable sensitivity-to-noise ratio over a period of several hours. From the same power supply, current is drawn to operate two vacuum tube triodes (6C4) in the dynamic side of the circuit. The first tube serves in a crystal-controlled oscillator in a conventional Pierce's circuit to produce a 500 kilo-cycle-per-second (keps) voltage while the second one performs as a cathode follower to separate the

Fig. 2.3. Schematic diagram of the electrical system.

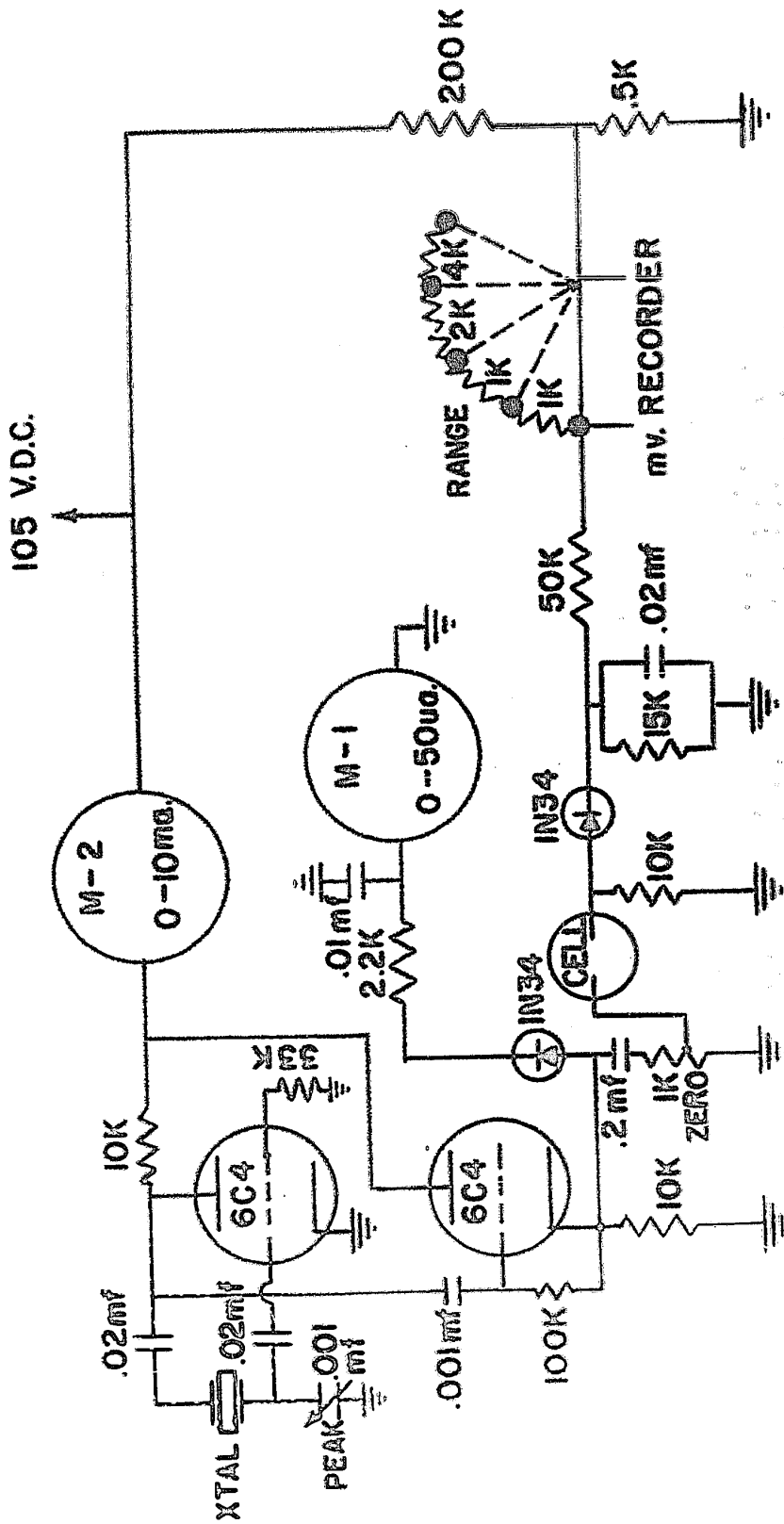

Fig. 2.3

oscillator from the detector cell. This high frequency voltage has been selected by performing frequency-response analysis on absorbent solution containing an equivalent of 1,000 p.p.m. of sulphur dioxide as sulphuric acid. After scanning through the frequency spectrum from zero to 5 megacycles per second, it has been observed that at the region of 500 kcps, the response is maximum (Fig. 2.4). By means of a potentiometer, this 500 kcps voltage is applied across the detector cell and a 10 k ohm resistor in series. It is further adjusted while the absorbent flows continuously through the detector cell, so that the voltage across the 10 k ohm resistor compares with the 0.25 volt reference after rectification and integration. Changes in impedance of the electrolyte resulting from the formation of sulphuric acid from the reaction of sulphur dioxide and hydrogen peroxide disturb the voltage balance. The voltage alteration bears a direct relationship to the amount of sulphur dioxide being absorbed. By recording the differential voltages in a millivolt recorder (Brown), the concentration of sulphur dioxide in the air sample can thus be estimated.

II. Experimental Procedures.

The analytical system was calibrated by drawing sulphur dioxide-air mixtures of known composition through the absorber. The rates of flow for gas and absorbing solution were at operational conditions (35 ml. and 5 ml. per minute respectively). Three calibration curves (Fig. 2.5) were obtained by plotting the concentration of sulphur dioxide in parts per million against the voltage output as observed in the millivolt-meter at three sensitivities, A, B and C. The results were confirmed

Fig. 2.4. The frequency-response curve for sulphur dioxide.

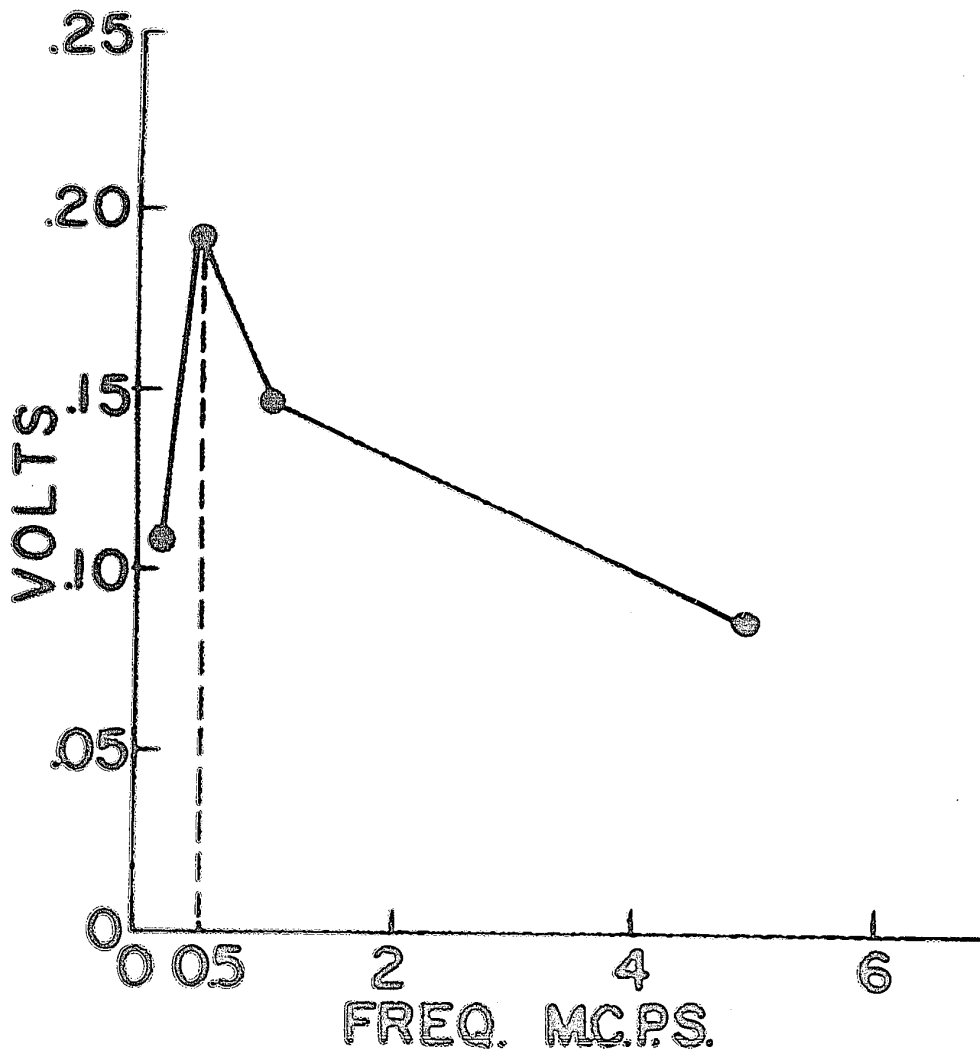

Fig. 2.4

Fig. 2.5. Calibration curves for the analytical system.

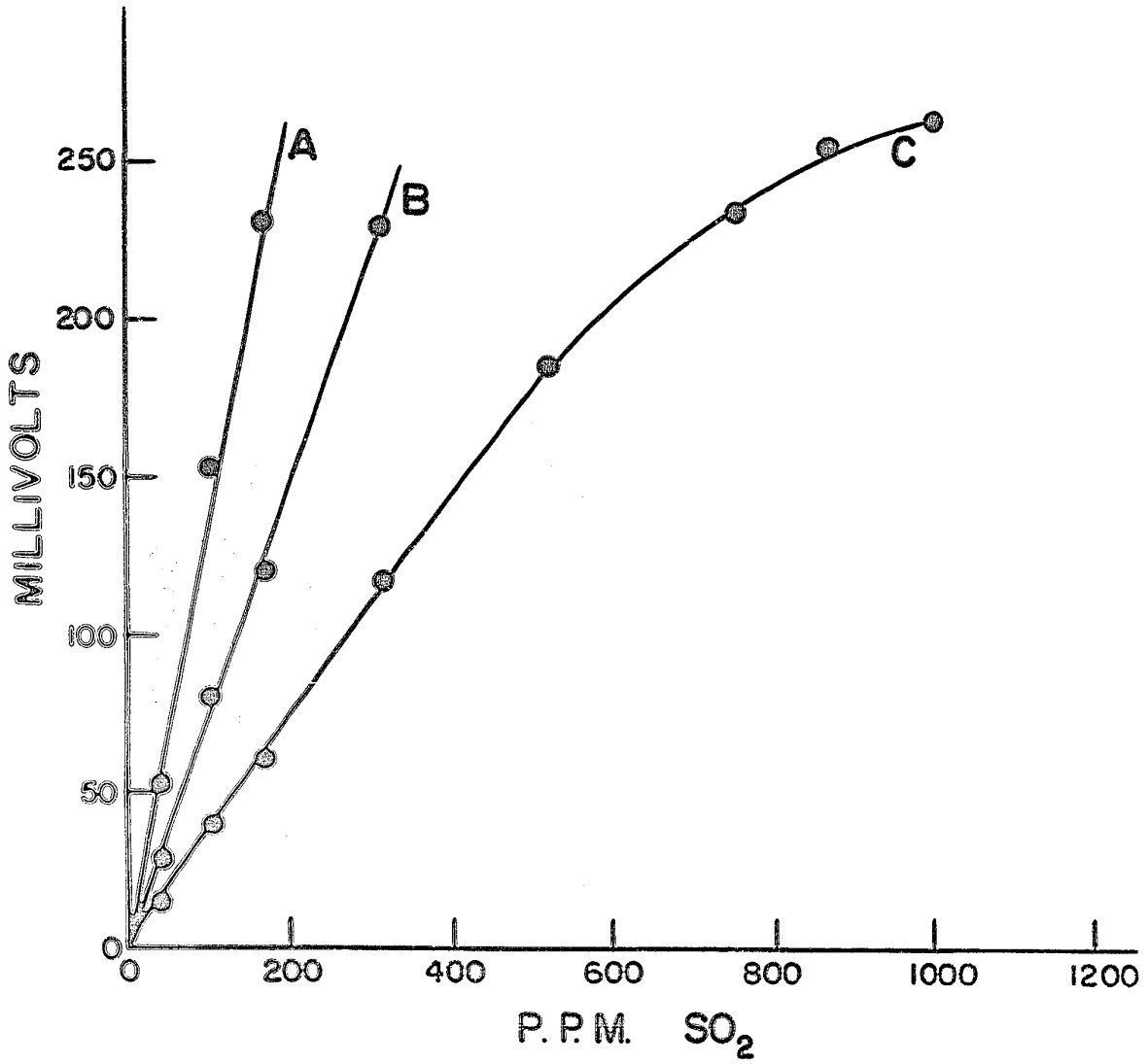

Fig. 2.5

by using a series of hydrogen peroxide-sulphuric acid solutions containing an equivalent of 5, 50, 100, 200, 300, 500, 750 and 1000 p.p.m. of sulphur dioxide. All procedures were carried out at room temperature which varied to an extent of $\pm 3^{\circ}\text{F}$.

III. Results and Discussion.

A. Efficiency.

The efficiency of the absorber for sulphur dioxide has been determined by analyzing simultaneously the equivalent amount of the gas in the supplying stream and in the effluent stream by a titrimetric technique. The following efficiencies were observed under operational conditions: 42 p.p.m., 100%; 167 p.p.m., 98.8%; 520 p.p.m., 98.4%; 866 p.p.m., 98.2%. (Table 2.1). It was also interesting to note that the presence of carbon dioxide in the effluent would change the titratable acidity enormously and yet the electrical response was amazingly small. This interference is discussed below.

B. Sensitivity and Range.

The sensitivity of the instrument at the three sensitivity levels is 1.38, 0.74 and 0.38 millivolt of output per 1 p.p.m. change in sulphur dioxide concentration in the range of 0-500 p.p.m. Beyond this range, the response becomes non-linear and at 600 p.p.m. the sensitivity falls to half of the initial value. The full scale deflection for each sensitivity level corresponds to 160, 320 and 800 p.p.m. respectively. The range of interest lies between 5 to 500 p.p.m. and the measurement of sulphur dioxide concentration within this span has been found

to be accurate to $\pm 5\%$. Theoretically, the limit of detection may be lowered or elevated many fold by altering the ratio of air and liquid volume appropriately. Since this instrument is designed for dosimetric inhalation studies in small animals, it was deemed undesirable to increase the sampling rate. On the other hand, the rate of flow of solution (5 ml. per minute) cannot be lowered without introducing a lag in the response.

C. Rate of Response.

The factor governing the rate of response of the system to changes in sulphur dioxide concentration in the air is the rate of solution displacement or exchange in the V-shaped detector cell. It was found that the insertion of a glass (or platinum) wire through the cell between the electrodes resulted in a reduction of equilibration time. This improvement has been shown to be associated with a change in liquid flow pattern in the cell resulting in a more rapid conduction of electrolyte to the vicinity of the electrodes. Empirical tests for the rate of response of the system were carried out in which a suddenly interrupted on-and-off supply of gas was made through a three-way stopcock at the sample inlet. It was observed that the response occurred almost instantaneously and reached 95% of the change in 30 seconds and 100% in 1-2 minutes, regardless of the sulphur dioxide concentration levels employed (Fig. 2.6).

D. Interference.

The analytical system was specifically designed for biological studies. The only interfering substance which might be present in

Fig. 2.6. Rate of response of the analytical system.

A.	14 p.p.m.	at sensitivity A.		
B.	66 p.p.m.	"	"	B.
C ₁	252 p.p.m.	"	"	C.
C ₂	516 p.p.m.	"	"	C.

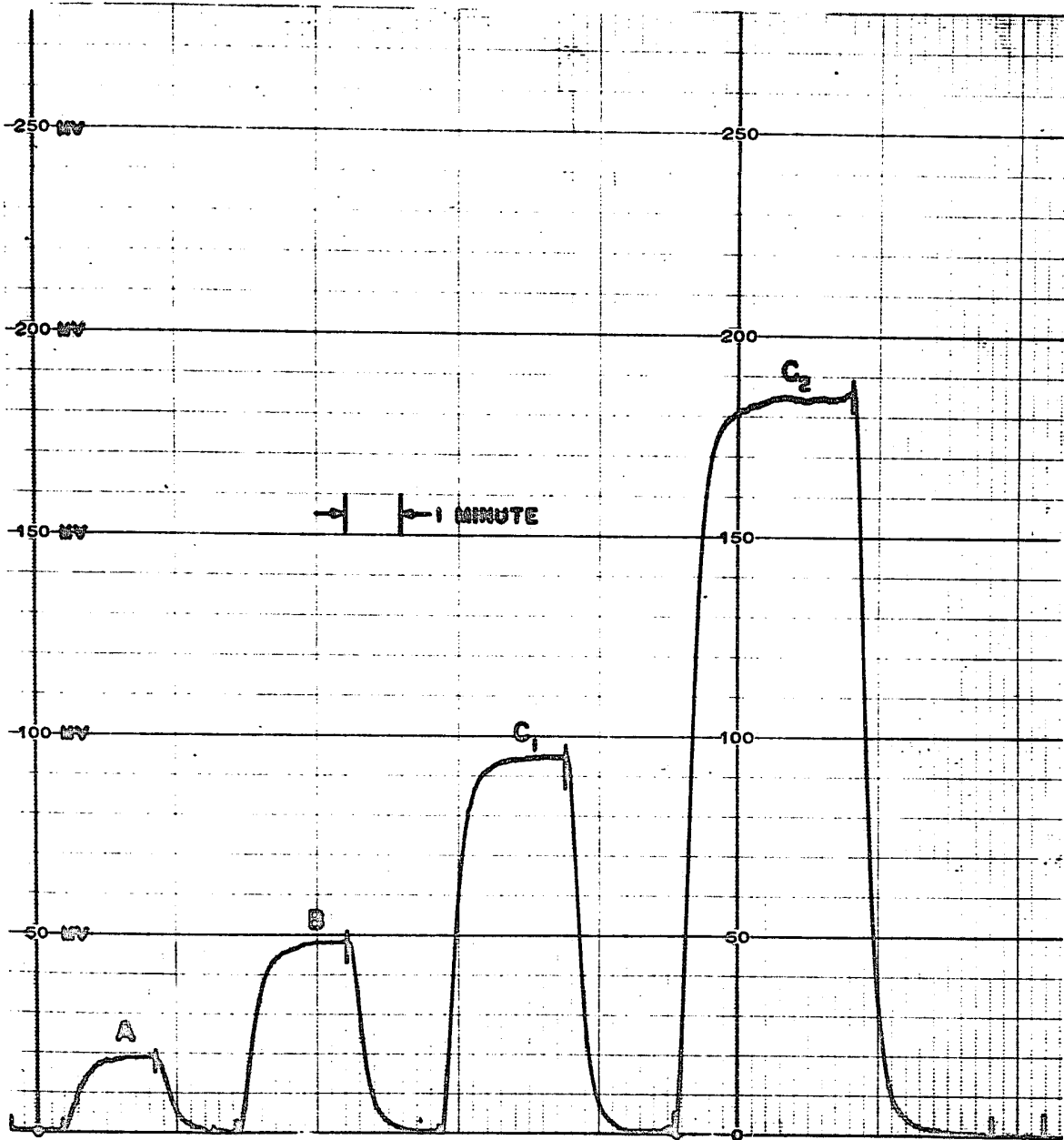

Fig. 2.6

the gas stream would be carbon dioxide. It was noted that, at all sulphur dioxide concentrations, the effect of the presence of 2% carbon dioxide was negligible. However, the presence of 5% carbon dioxide altered the recordings by 8% at 42 p.p.m., 4% at 167 p.p.m. and 1% at 520 p.p.m. of sulphur dioxide (Table 2.2).

E. Applicability.

Any gases which react with a suitable fluid medium to produce an electrolyte will be detectable. It is anticipated that the instrument may be adapted for the analysis of gases such as hydrogen sulphide, nitrogen dioxide or ammonia provided they are measured at suitable frequency voltages.

Table 2.1. Efficiency of the absorber at different sulphur dioxide concentration levels.

Number of Determinations	SO ₂ Concentration-p.p.m.		Percent Absorption
	Impinger	Absorber	
6	42 ± 8	42 ± 7	100.7
9	166 ± 7	164 ± 3	98.8
9	312 ± 7	306 ± 5	98.1
8	521 ± 10	513 ± 9	98.4
8	866 ± 20	851 ± 12	98.2

Table 2.2 Effect of CO₂ on SO₂ determination by the analyzer.

Number of Determinations	Observed SO ₂ Concentration-p.p.m.			
	CO ₂ Concentration in Air Stream			
	0% (Air)	2%	5%	10%
6	36 ± 4	39	39	45
9	157 ± 5	165	168	168
9	291 ± 2	310	315	321
8	489 ± 20	492	496	514
8	673 ± 20	924	910	910

* Two determinations in each trail.

CHAPTER THREE
PULMONARY RETENTION
OF
SULPHUR DIOXIDE BY THE RAT

PART I. LITERATURE SURVEY

I. Introduction.

The classical method of describing quantitatively the magnitude of an exposure of an animal to a gaseous toxicant is to state the product of the concentration of the agent times the duration of the exposure⁽⁵⁸⁾. The concentration, C , is usually given in mg./cu.m. and the time, t , in minutes. Thus, the exposure is characterized by some Ct , in the units mg. min./cu.m. The product, Ct , has been used extensively to describe gas exposures with the assumption that the same quantitative response of the organism might be expected for various values of C or t , provided (Ct) is equal to a constant, K . It is now known that this assumption is in general, incorrect and may serve only as an approximation of the effect of a given Ct over restricted ranges of C and t ⁽⁵⁹⁾. It must further be emphasized that the product, Ct , is not the actual dose of agent retained by the animal. It may be proportional to the dose only if the fraction of agent retained in each inspiration remains constant and the various physiological parameters that constitute the minute volume also remain unchanged throughout the exposure. However, several experimental studies have revealed that individual animals of the same species respond differently to various gaseous toxicants depending on the mode of action of the agent. The inhibition⁽⁶⁰⁾ or stimulation⁽⁶¹⁾ of respiration by the agent may result in wide discrepancies between concentration-time products (Ct) and the dose actually retained. Thus, the use of Ct as a measure of dose in the determination of

individual and species susceptibility to inhaled agent has been proven unsatisfactory. Attempts have been made in larger animals to obtain an estimate of the actual dose. The procedure employed is called the dosimetric method. The amount of agent retained per unit body weight during an inhalation exposure is given by the expression:

$$D = \frac{A(Ct) V}{W}$$

where
D = dose
W = body weight in gram
V = minute volume (tidal volume x respiratory rate)
A = percentage retention (the quotient of the amount of agent retained by the animal divided by the total amount to which the animal was exposed).

Thus the true dose of the agent may be determined provided estimates of A and V are obtained in addition to the conventional measurements of C and t. In effect this equation still requires the assumption that the average minute volume, V, and the fraction of the inhaled agent are constant for a given species. It is now recognized that the percent retention, A, of a given agent may vary among animal species as well as among members of a given species. Conversely, different agents may be absorbed in variable quantity by the same species. This variation may be due to physiological or anatomical factors or the route of inhalation (62,63,64). Furthermore, the physical or chemical properties such as solubility (65,66) or reactivity (67) of an agent may also affect the degree of retention. Although some information on A has been obtained from in vitro and short term in vivo experiments, very little is known regarding the changes in A with respect to concentrations of the agent and the

duration of the inhalation exposure. Consequently, the present studies are designed to examine the possible alteration of α with respect to concentration levels and duration when rats are exposed to one of the most prominent air pollutants--sulphur dioxide.

II. Sulphur Dioxide.

Sulphur dioxide is one of the most prominent atmospheric contaminants in large cities and industrial towns^(68,69,70). Although it is not as chemically active as ozone and fluorine compounds, yet it is emitted in much greater quantity and may reach a high enough concentration to constitute a health hazard^(70,71,72). Consequently, the rise and fall of the level of the gas has been chosen as an index of gaseous pollutant. The recommended threshold limit value for sulphur dioxide is 5 p.p.m. (13 mg. per cubic meter)⁽⁷³⁾. Physiologically, sulphur dioxide is classified as an upper respiratory irritant gas which exerts the common property of inducing inflammation in the membrane of respiratory tract⁽⁷⁴⁾.

III. Reviews on Sulphur Dioxide Studies.

A. Symptomatic and Pathological Aspect.

Many studies have been published in which the responses and pathological changes associated with exposure to sulphur dioxide have been related to the irritating and corrosive properties of the gas. Chronic, intermittent inhalation of sulphur dioxide below the concentration of 5 p.p.m. in animals and man is believed to present no appreciable danger to health^(75,76). However, chronic, continuous exposure to similar low level of the gas have been shown to cause disturbances of the conditioned

reflexes in rats⁽⁷⁷⁾. Furthermore, when animals were exposed to a moderate level of the gas under similar prolonged conditions, general damage to the pulmonary, circulatory and central nervous systems⁽⁷⁸⁾ as well as effects on carbohydrate and protein metabolism and alkali reserve⁽⁷⁹⁾ occurred. The sum of these reactions would subsequently shorten the life span of the animals⁽⁸⁰⁾. In short term experiments, acute poisoning of normal^(81,82,83,84) or "sensitized"⁽⁸⁵⁾ animals by high concentration of sulphur dioxide led to severe pulmonary damage and failure.

Recently, attention has been centred on the investigation of the effects of sulphur dioxide upon various physiological parameters such as tracheobronchial reflexes^(86,87,88), pulmonary compliance and air-flow resistance in animals^(89,90) and man^(91,92,93). It has been concluded that at very low concentrations the primary action of sulphur dioxide is to cause broncho-constriction and an increase of the pulmonary flow resistance. However, the experimental animals or subjects can usually recover within a few hours.

Since all body reactions to adverse conditions may ultimately be traced down to the cellular level, the effects of sulphur dioxide upon established cell lines cultivated in vitro have also been the subject of investigation⁽⁹⁴⁾.

B. Percent Retention Studies.

Attempts to measure the percent retention, α , of an inhaled toxicant are few in number and are deemed to be

difficult because of the problems involved in the collection of a sample of expired air containing a sufficient amount of toxic agent for chemical analysis. Most of the investigations have dealt with war gases such as phosgene⁽⁶⁰⁾ and sarin⁽⁹⁵⁾ on larger animals. There is practically no experiment designed specially for the determination of the percent retention of sulphur dioxide, except a few reports^(88,96,97) with a limited amount of data on this important entity along with pulmonary dynamic studies in anaesthetized dogs. The method employed in all cases involved the use of a one-way valve system in conjunction with a face-mask or tracheal cannulation. Ventilation of the animal was maintained by means of a respiration pump which supplied a constant stroke volume of sulphur dioxide-air mixture. The inhaled gas was then actively drawn out or passively exhaled against atmospheric pressure and delivered into a Mylar bag or other types of gas collecting systems. The volumes of gas inspired and exhaled over the experimental period were measured. Gas samples from both sources were analyzed for sulphur dioxide concentration by means of wet chemical methods or appropriate detectors. The average percent retention over a period of several minutes or an hour could thus be calculated.

IV. Comments on Percent Retention Studies.

Review of the reported studies in which estimates were obtained of the percent retention reveals a number of drawbacks in the experimental procedures. In the first place, the animals have been

subjected to anaesthesia and surgical procedures. The application of artificial pulmonary ventilation is apt to interfere with normal physiological responses and the protective mechanisms such as alteration of respiratory pattern or mild bronchio-constriction. The variation of these parameters may, as has been discussed, affect the percent retention of a gas by the pulmonary system of an animal. Secondly, the estimates of percent retention of sulphur dioxide for those animals were merely the average values measured over a period of several minutes or as long as an hour. Therefore, any possible alteration in retention with respect to the duration of exposure would be masked. Thirdly, most of the experiments have been carried out within a narrow range of sulphur dioxide concentrations, making it difficult to detect any possible change in percent retention due to differences in concentration. Finally, the use of valve systems adds to the problems of gas analysis under these circumstances.

From the above comments, it is evident that there is a need for a method capable of measuring various respiratory parameters under conditions as nearly natural as possible. Moreover, an electrochemical analytical system, which will permit detection of the minute differences in concentration of the agent in the inspired and expired air of small animals, must be employed. It is also considered desirable to record all these parameters instantaneously and continuously so that the percent retention of the gas by the animal can be calculated for both limited periods and the entire course of the experiment.

PART III. EXPERIMENTAL RESEARCH

I. Materials and Methods.

A. Percent Retention System.

This system is made up of the tidal volume measurement and sulphur dioxide analytical components. Both of these two new developments have been described in detail respectively in chapters one and two, and in publications^(98,99). Figure 3.1 is a photograph of a simple tap-system which unites the two systems and synchronizes their functions to provide the necessary data for the calculation of the instantaneous percent retention of the gas by an experimental animal. This tap system, is constructed by soldering two No. 18 B.D. hypodermic needles onto the two opposite arms of a three-way stopcock. The tips of the needles are smoothed and embedded into the upstream and downstream sides of the main air supplying tube. A small screw of 1/8" diameter is threaded into a tapped hole in the collar of the hypodermic needle on the upstream side. By adjusting the depth of the screw, the air-flow pressure in the upstream sampling inlet is thus equalized to that of the downstream. This arrangement ensures that equal volumes of gas are drawn for analysis. The third arm of the tap leads to the sampling part of the counter-current absorber. Thus, the concentrations of sulphur dioxide in the inspired air and downstream air (a mixture of expired and uninhaled air) can readily be analyzed alternately.

The ventilatory parameters are measured in the same manner

Fig. 3.1. Photograph of the tap system.

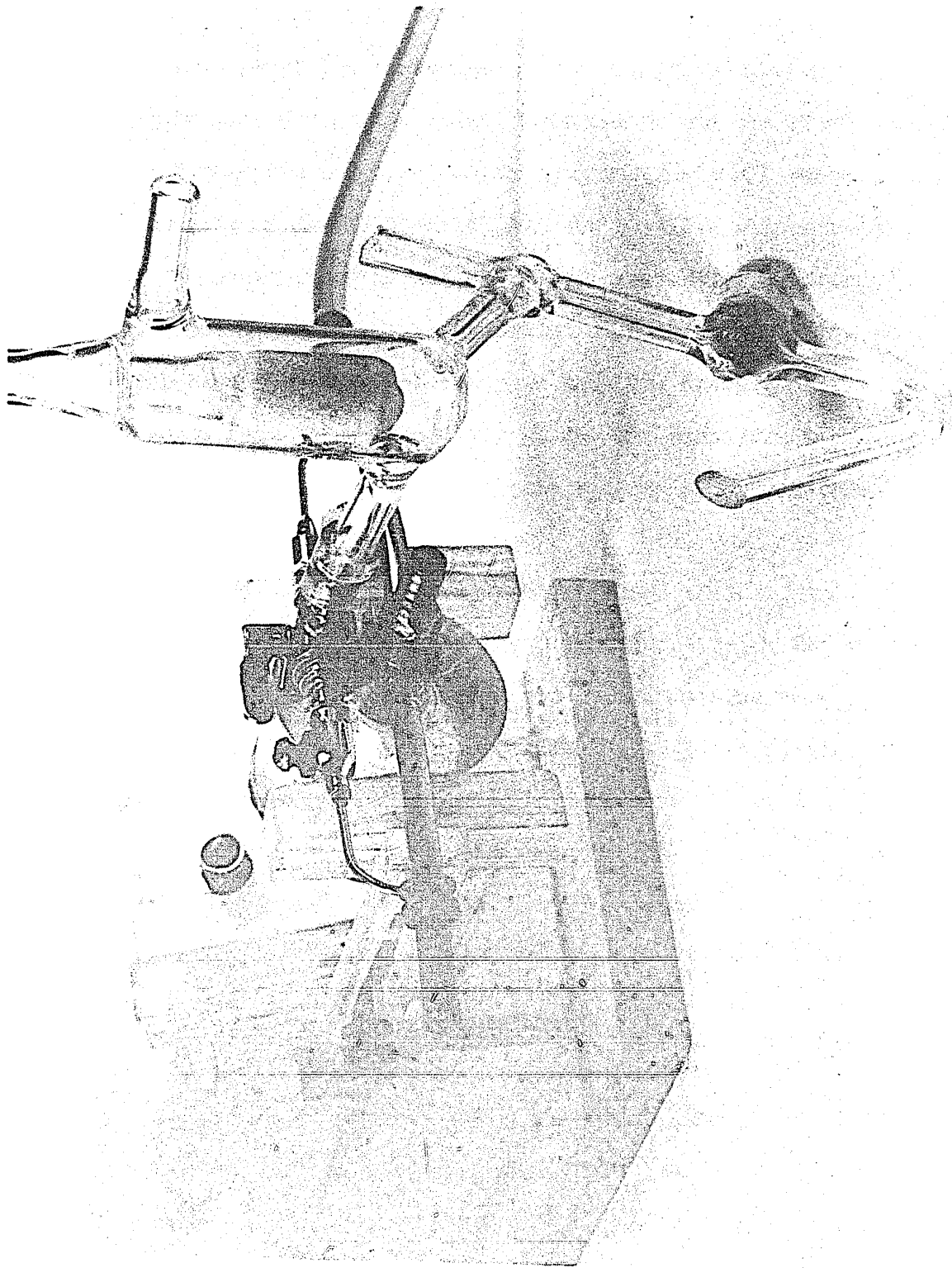

FIG. 3.1

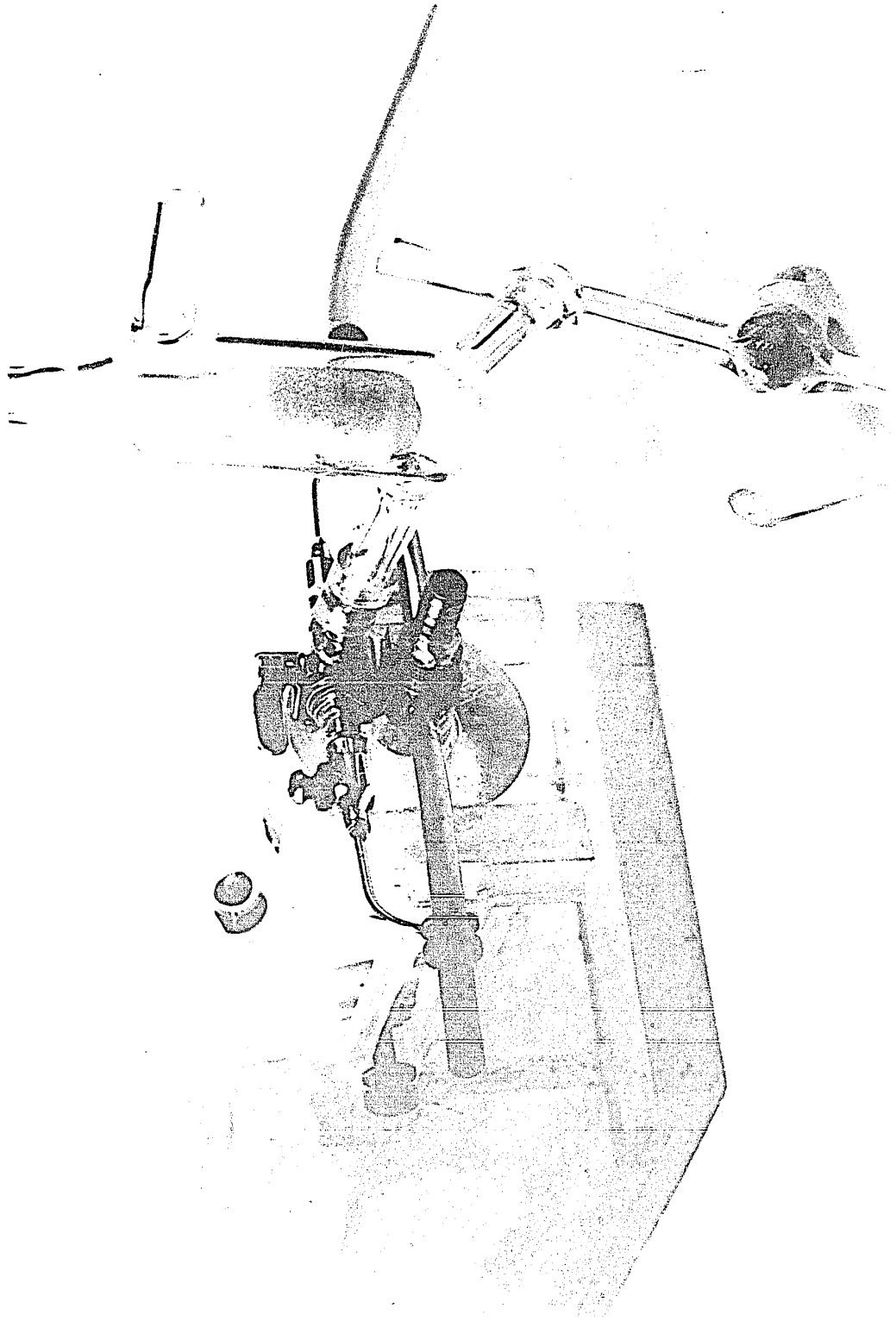

Fig. 3.1

as previously described in chapter one. The opening, B, located opposite the outlet of the face-mask leads to the pressure sensitive transducer. The changes of pressure within the tube as the animal breathes in and out of the system are integrated with respect to time to give tidal volume. The frequency of fluctuation of pressure provides also a measure of the respiratory rate. The minute volume is, however, obtained by simultaneous summation of each tidal volume on a time base. It has been observed that the drawing of air samples from either locations on the air supplying tube does not affect the measurement of the respiratory parameters.

B. Gas Supply System.

The main tube of the apparatus is fed at a constant rate with air containing a known concentration of the toxicant. For sulphur dioxide, pure air and air containing about 8000 p.p.m. of sulphur dioxide are proportioned through two by-pass flow regulators and the final mixture is metered by means of a third regulator directly into the main gas tube. In this manner, a steady, pulseless flow of sulphur dioxide in air in the concentration range 0-1000 p.p.m. is readily obtained (Fig. 3.2).

C. Method of Analysis.

Earlier techniques for the determination of the percent retention, Q , of a gas or vapour by an experimental animal required the use of a valve system. Calculation of this

Fig. 3.2. Gas supply system.

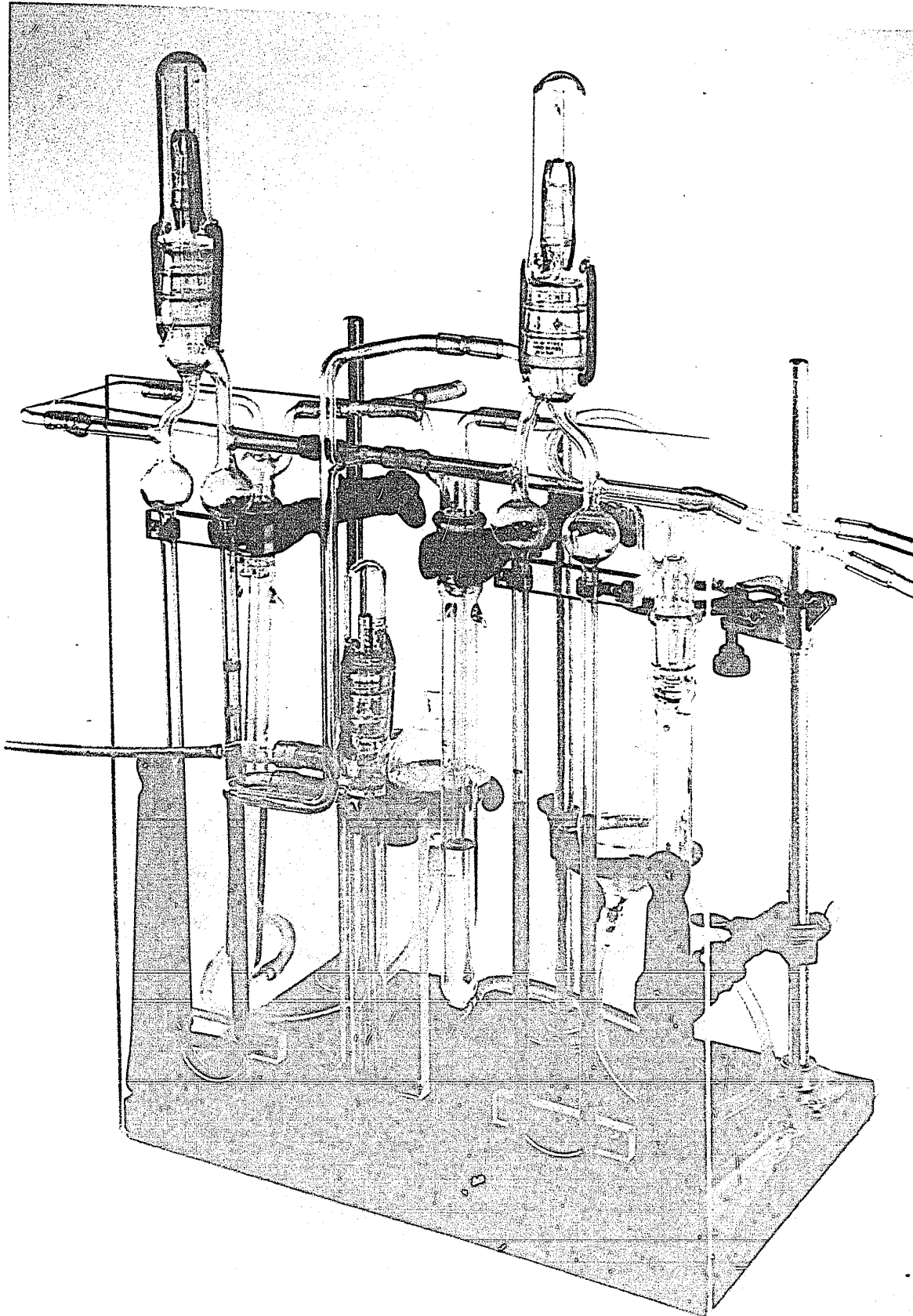

Fig. 3.2

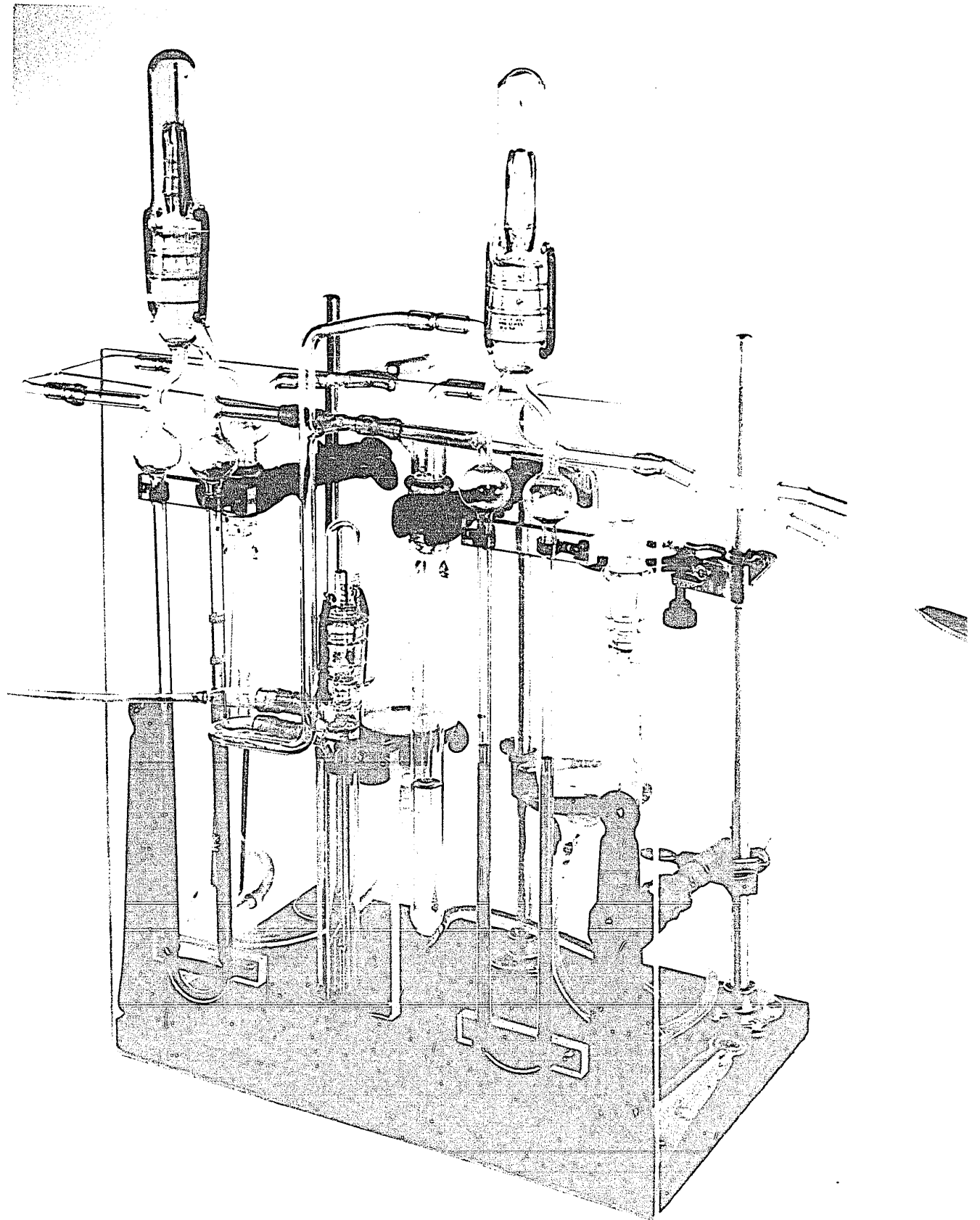

Fig. 3.2

parameter was made by using the following equation (100).

$$d = 100 \frac{D(V_t b - D a) + a (V_t - D) - V_t \frac{(V_t b - D a)}{(V_t - D)}}{D(V_t b - D a) + a (V_t - D)}$$

- where D = Apparatus dead space (l)
V_t = Mean tidal volume (l)
a = Vapour concentration entering the inhalation apparatus (µg/l)
b = Vapour concentration leaving the inhalation apparatus (µg/l)

This equation is complex in form because of the necessity of including terms for the dead space correction.

The development of the present valveless, open circuit, air-flow respirographic technique simplifies the whole equation to the following:

$$d = 100 \left[\frac{a - b}{a} \right]$$

Although in the measurement of b, account must be taken of the fact that there is mixing of uninhaled gas with exhaled gas. However, the final equation can easily be derived as follows:

Let a be the initial concentration of the sulphur dioxide-air mixture which is supplied at a constant rate of V ml. per minute and let V_m be the volume of gas inhaled by the animal per minute. This V_m must also be equal to the volume of gas exhaled by the animal per minute. Let b be the gas concentration leaving the respiratory system of the rat. Then, the final concentration (C_F), which one would detect at the downstream of the apparatus would be

$$C_F V = a (V - V_M) + b V_M$$

$$= a V - a V_M + b V_M$$

$$\frac{C_F V - a V + a V_M}{V_M} = b$$

$$\alpha = 100 \left[a - \frac{(C_F V - a V + a V_M)}{V_M} \right]$$

$$= 100 \left[\frac{a V_M - C_F V + a V - a V_M}{a V_M} \right]$$

$$= 100 \left[\frac{a V - C_F V}{a V_M} \right]$$

$$= 100 \left[\frac{V}{V_M} \cdot \frac{a - C_F}{a} \right]$$

Since V, the gas supply, is a known quantity, while V_M and C_F are measurable parameters, α can therefore be readily calculated. Fig. 3.3 is a sample of the type of tracings obtained for calculation. Fig. 3.3(1) shows the respiratory pattern of the animal undergoing an inhalation exposure to sulphur dioxide and Fig. 3.3(2) shows the equivalent minute volume. Fig. 3.3(3) shows the initial concentration of sulphur dioxide in the air stream and the corresponding fluctuations in concentration as the animal breathes in different respiratory patterns. Confirmation of the upstream concentration is obtained by the restoration of the curve to the initial value.

D. Statistical Method.

Determination of the mean value of percent retention of sulphur dioxide by rats undergoing inhalation exposure to

Fig. 3.3(1). Typical respiratory patterns of rats exposed to 42 p.p.m. of sulphur dioxide.

(2). Equivalent minute volume.

(3). Alterations of the concentrations of sulphur dioxide before and during inhalation exposure.

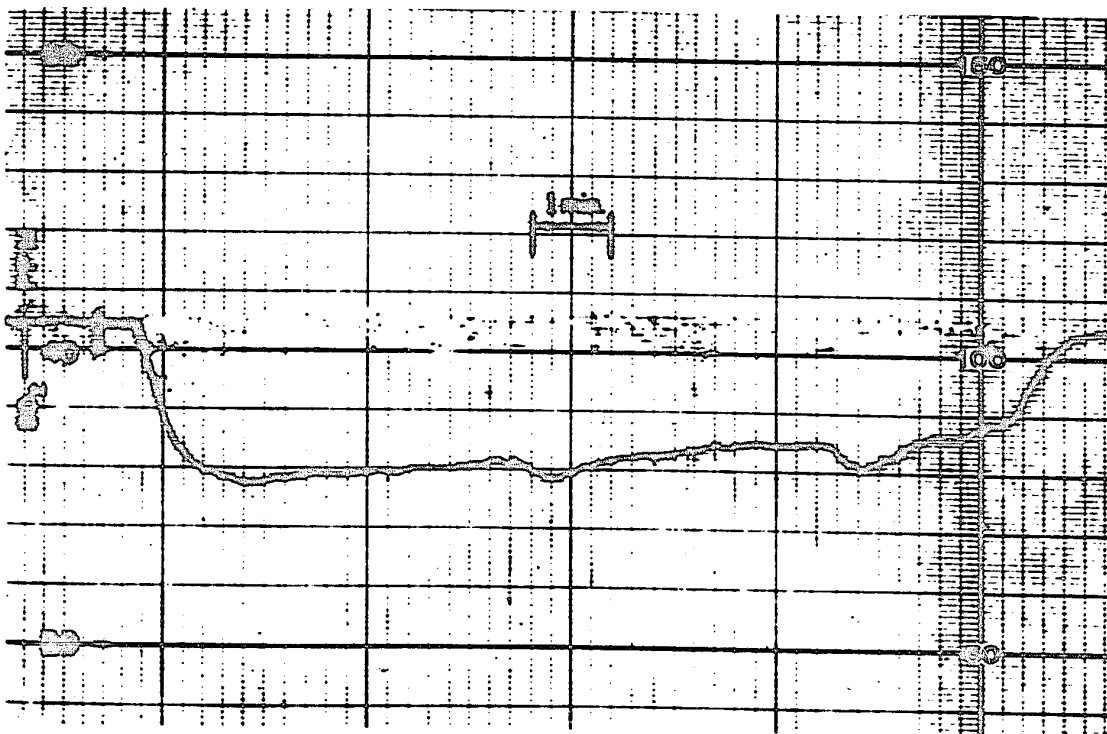
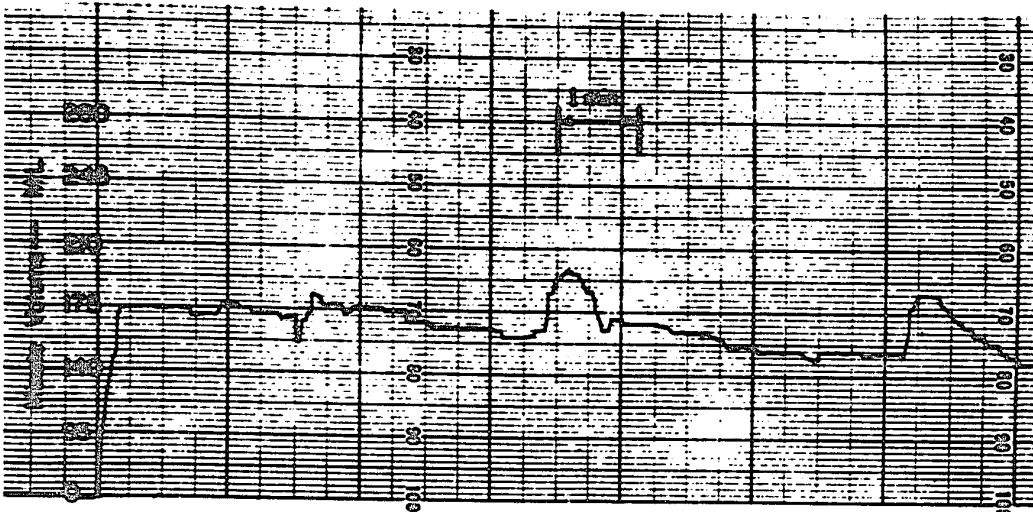
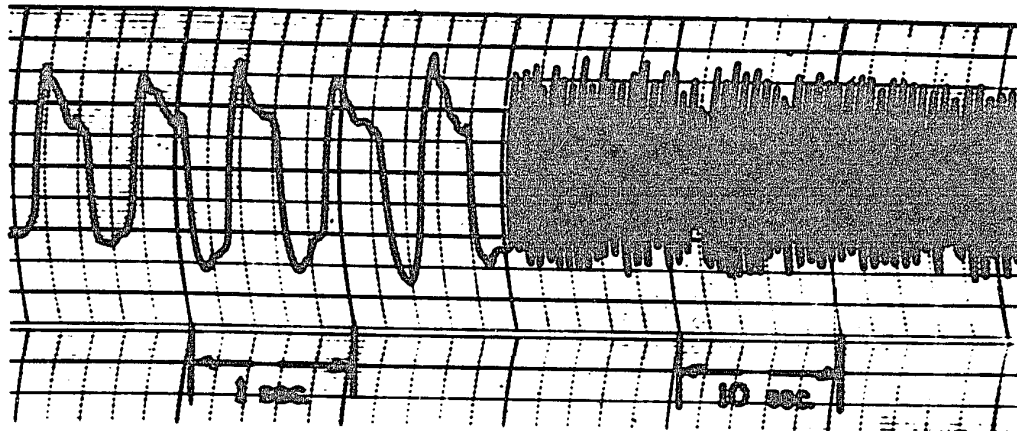

Fig. 3.3

different concentrations of the gas was the form of experimentation employed. Seven groups of 10 animals each were exposed to different concentrations of the gas ranging from 40-750 p.p.m. The values for percent retention of sulphur dioxide by individual rats at different designated time points were calculated according to the derived formula. These values together with the minute volume, respiratory rate and the calculated tidal volume (minute volume divided by respiratory rate) at the corresponding time points were then subjected to a multiway analysis of variance and Duncan's multiple range test for significant differences between treatments and time effect⁽¹⁰¹⁾.

E. Choice and Care of Animals.

Male albino rats of the Wistar strain were used throughout the experiments. They were young adult rats weighing from 200 to 220 grams. These animals were supplied by the Environmental Health Centre Laboratory in Ottawa. Immediately after the arrival of the animals, they were housed in standard cages and provided with water and Purina chow. Three to six days of acclimatization to laboratory conditions were given before they were used in the experiments.

F. Histological Method.

Lungs from all animals in each trial were prepared as follows⁽¹⁰²⁾: the anterior portion of the trachea was tied off and the lungs distended to normal size by injection of Bouin's fixative. The trachea was then tied again below the point of injection. After embedding and cutting, the sections

were stained with Harris' hematoxylin and eosin, and mounted slides were prepared according to standard procedures.

II. Experimental Procedures.

At the beginning of each experiment, the ventilatory measuring system was calibrated by the method previously described (page 12). The sulphur dioxide analytical system was calibrated by supplying the counter-current absorber-detector with sulphur dioxide-air mixtures of known compositions. Gas samples were drawn first from the upstream tap and then from the downstream tap. This procedure was carried out to ensure that the sampling rates through both taps were identical. Discrepancy in analytical concentrations between upstream and downstream samples could be corrected by turning the screw, in the collar of the hypodermic needle in the upstream side, to decrease or increase the sampling rate. When all instruments were calibrated, the experimental animal was then inserted into the holder with its muzzle projecting through a gas tight face-mask. The animal was allowed to rest for a short period before the mask outlet was coupled onto the main transverse gas supplying tube. During the course of each experiment, the sulphur dioxide concentration in the gas circuit was checked at 10-minute intervals by drawing gas samples from the upstream tap. Immediately after this inspection, the sampling mechanism was again switched back to the downstream tap. Recordings of various physiological and analytical data proceeded simultaneously and continuously for a period of two hours. The readings from the various tracings were transposed into their exact values by interpolation of the appropriate calibration curve. The values for percent retention of sulphur dioxide for each

concentration level were calculated according to the formula. At the end of the two-hour exposure, the experimental animal was anaesthetized with mumbatal and the lungs were removed for histological examination.

III. Observations.

The immediate response of the control animals to a sudden change of air supply was in general a decrease in respiratory rate followed by a rapid recovery to the normal respiratory pattern. On the other hand, the first response of the experimental animals to a sudden change of atmospheric constituents was the holding of breath for a period of ten to fifteen seconds. As breathing resumed, evidence of irritation was indicated by sneezing, coughing and lachrymation, together with considerable struggling. These signs of irritation continued for 4 to 5 minutes and the animals appeared to adapt themselves to the new situation. They became progressively inactive and lethargic. Respiratory function in those animals which were exposed to the intermediate levels of sulphur dioxide, from 40-400 p.p.m., recovered quite rapidly. However, the respiration of animals undergoing an inhalation exposure to the high concentration, 750 p.p.m., of the irritant gas became erratic and laboured. The respiratory pattern was an intermittent burst of quick and deep inspiration and expiration. Consequently, the time required for each respiration became shorter even though the number of respirations per unit time was small. Respiratory failure in this group of animals occurred frequently during the

experimental period. Finally, most of the animals undergoing inhalation exposure to sulphur dioxide salivated profusely while the control animals remained quite normal.

IV. Results.

The percent retention of each of the ten animals was calculated at one-minute intervals for the first ten minutes and then at ten-minute intervals throughout the rest of the experiment (120 minutes). The physiological and analytical parameters at the corresponding time points were likewise recorded or calculated. However, after a preliminary examination of the data, it was concluded that the original 21 time-points for each curve could be reduced to seven points and still provide a full picture of the whole experiment. This simplifying process greatly facilitated the graphical presentation of the data and statistical analysis.

Table 3.1, 3.3, 3.5 and 3.7 show the mean values of percent retention, respiratory rate, tidal volume, minute volume and their respective standard deviations. Horizontal rows of values provide the comparison of each parameter measured at different time-points while the animals were exposed to a single concentration of the irritant gas. Vertical columns of entries give the comparison of the values obtained at the same time-points but at different levels of sulphur dioxide. Figures 3.4, 3.5, 3.6 and 3.7 are the respective graphical presentation of the tables.

Tables 3.2, 3.4, 3.6 and 3.8 are the results of statistical analysis of the data of Tables 3.1, 3.3, 3.5 and 3.7, employing the methods of variance analysis and the Duncan's multiple-range test.

In general, percent retention, respiratory rate and minute volume varied inversely to the concentration of sulphur dioxide, whereas tidal volume varied directly. On the other hand, the duration of an exposure affected solely the percent retention.

Table 3.1. The values of mean percent retention (O) with standard deviations of groups of rats exposed to different concentrations of sulphur dioxide.

Sulphur Dioxide Concn.	Time in Minutes							
	1	6	10	30	60	90	120	
A - 41	60.18 ± 6.17	52.67 ± 14.21	57.79 ± 11.53	52.24 ± 8.67	53.42 ± 7.75	54.48 ± 8.60	51.87 ± 11.62	
B - 64	55.79 ± 11.79	52.06 ± 11.05	53.28 ± 12.21	52.47 ± 9.11	47.63 ± 12.61	45.97 ± 15.47	45.30 ± 19.42	
C - 83	51.90 ± 7.77	47.78 ± 10.96	48.94 ± 8.19	45.31 ± 7.87	47.70 ± 8.61	39.96 ± 10.43	37.48 ± 12.61	
D - 145	44.14 ± 7.28	38.95 ± 8.82	39.56 ± 7.71	37.86 ± 14.70	38.91 ± 13.00	37.95 ± 11.45	38.34 ± 8.43	
E - 231	39.48 ± 16.39	39.66 ± 12.61	39.97 ± 12.00	40.77 ± 13.25	33.22 ± 13.27	35.49 ± 6.32	36.65 ± 7.28	
F - 426	36.42 ± 12.29	37.71 ± 8.71	33.32 ± 8.66	37.41 ± 12.13	29.17 ± 12.25	33.43 ± 11.09	27.92 ± 7.49	
G - 751	34.60 ± 9.85 ⁽⁸⁾	33.36 ± 11.02 ⁽⁸⁾	30.98 ± 10.21 ⁽⁸⁾	27.51 ± 9.65 ⁽⁸⁾	25.00 ± 9.71 ⁽⁸⁾	27.19 ± 11.63 ⁽⁵⁾	27.22 ± 11.76 ⁽⁴⁾	

(): Number of animals.
Not indicated: 10 Animals.

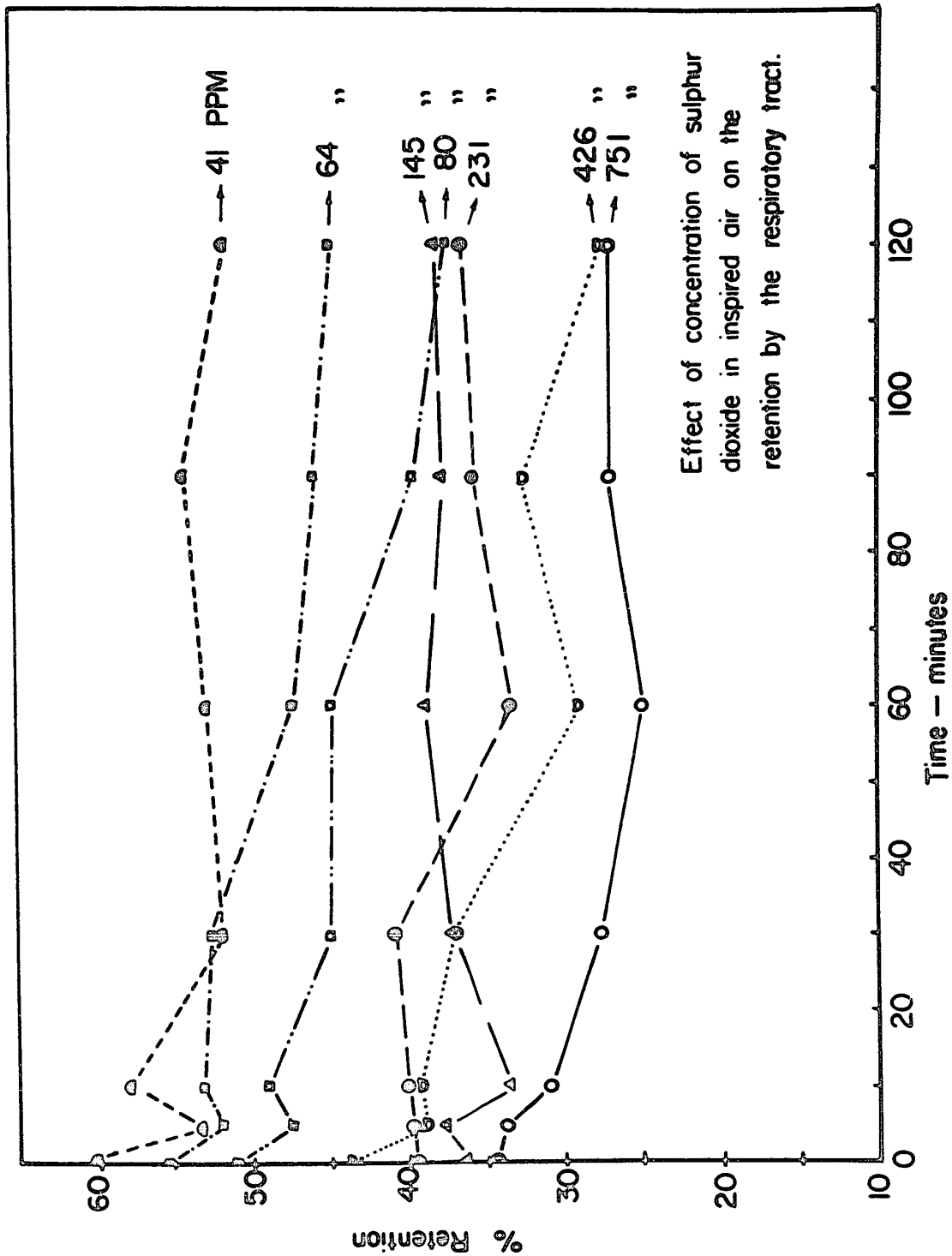

Effect of concentration of sulphur dioxide in inspired air on the retention by the respiratory tract.

Fig. 3.4

Table 3.2. Analysis of Variance and Duncan's Test of the relationship between concentrations of sulphur dioxide, duration of exposure and the value of percent retention.

Source of Variation	Sum of Squares	Degrees of Freedom	Mean Square	F. Value
Total	680461	468	-	
Treatment	30925	6	5154.2	68.8**
Blocks	293786	6	489.6	6.5**
Residual	34184	456	74.9	

Duncan's Test

(I) Concentration effect. A B C D E F G

(II) Time effect. 120 60 90 30 5 10 1

Any two means underscored by the same line are not significantly different.

95%

99%

Table 3.3. The values of mean respiratory rate with standard deviations of groups of rats exposed to different concentrations of sulphur dioxide

Sulphur Dioxide Concn.	Time in Minutes							
	1	6	10	30	60	90	120	
0	102 ± 15	97 ± 15	93 ± 15	95 ± 18	96 ± 27	93 ± 16	90 = 13	
A - 41	79 ± 25	71 ± 19	80 ± 14	85 ± 13	91 ± 14	93 ± 11	89 = 14	
B - 64	92 ± 14	86 ± 14	72 ± 16	87 ± 6	87 ± 8	83 ± 5	82 = 14	
C - 83	89 ± 17	75 ± 17	75 ± 15	83 ± 14	82 ± 12	83 ± 10	86 = 14	
D - 145	96 ± 23	73 ± 28	81 ± 23	78 ± 7	77 ± 9	68 ± 24	80 = 5	
E - 231	82 ± 14	70 ± 13	72 ± 18	70 ± 5	70 ± 16	74 ± 13	69 = 19	
F - 426	65 ± 17	59 ± 20	62 ± 8	79 ± 23	67 ± 13	67 ± 20	62 = 23	
G - 751	54 ± 21 (8)	42 ± 11 (8)	44 ± 17 (8)	45 ± 24 (6)	52 ± 21 (8)	52 ± 23 (5)	50 = 25 (4)	

(): Number of animals.
 Not indicated: 10 Animals.

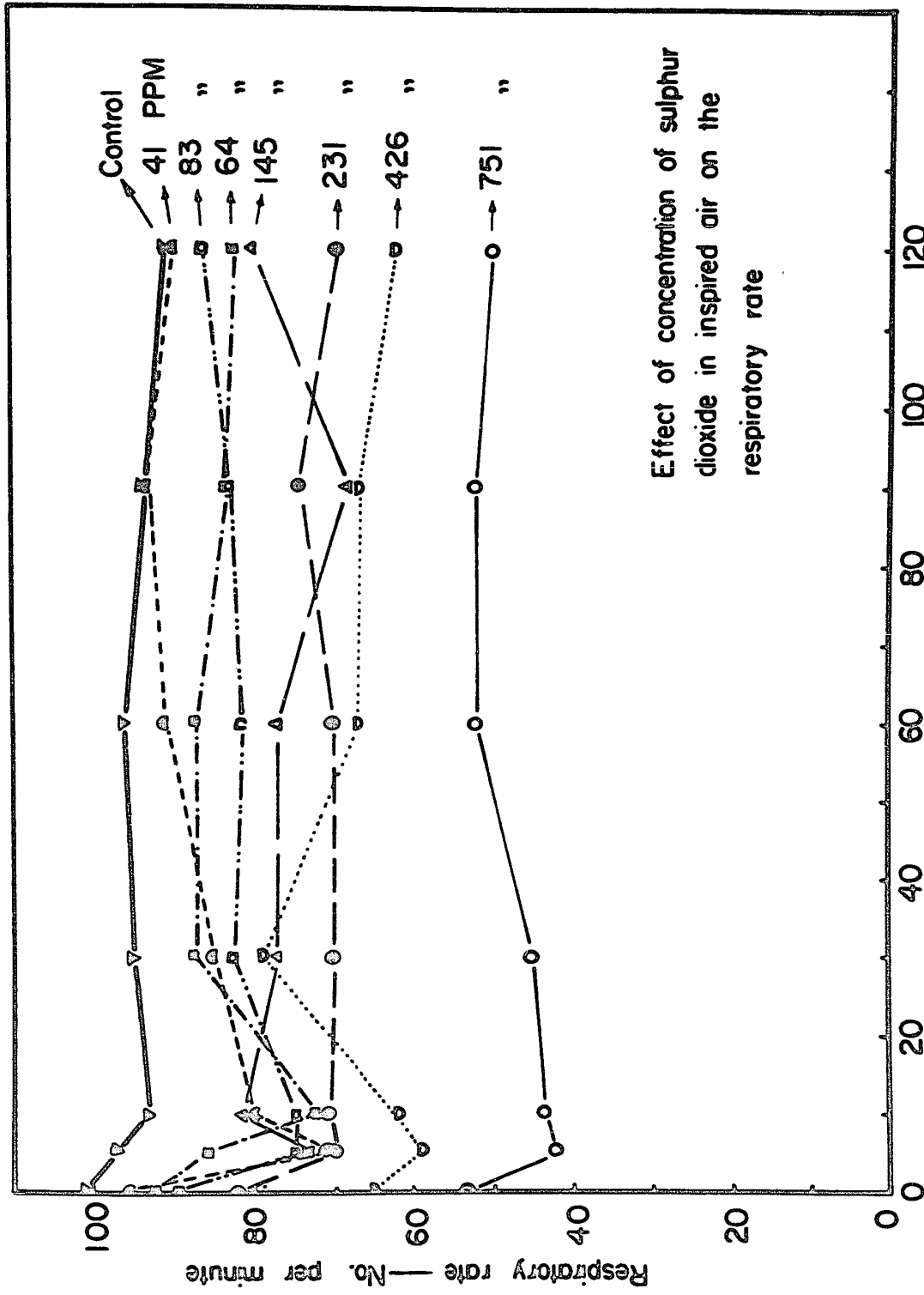

Time — minutes

Fig. 3.5

Table 3.4. Analysis of Variance and Duncan's Test of the relationship between concentrations of sulphur dioxide, duration of exposure and respiratory rate.

Source of Variation	Sum of Squares	Degrees of Freedom	Mean Square	F. Value
Total	236835	539	-	
Treatment	70292	7	10042	9.6**
Blocks	6259	6	1403.2	3.4**
Residual	160282	526	305	

Duncan's Test

(I) Concentration effect. 0 B A C D E F G

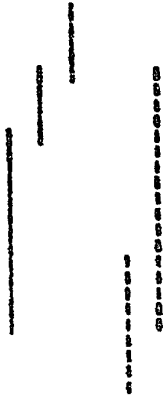

(II) Time effect. 5 10 120 90 60 30 1

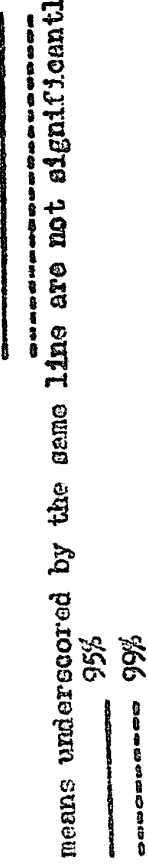

Any two means underscored by the same line are not significantly different.

95%

99%



Table 3.5. The values of mean tidal volume with standard deviations of groups of rats exposed to different concentrations of sulphur dioxide.

Sulphur Dioxide Concn.	Time in Minutes						
	1	5	10	30	60	90	120
0	1.80 ± 0.32	1.86 ± 0.32	1.86 ± 0.21	1.89 ± 0.26	1.83 ± 0.35	1.95 ± 0.33	1.91 ± 0.26
A - 41	2.12 ± 0.38	1.96 ± 0.41	2.09 ± 0.35	1.88 ± 0.23	1.84 ± 0.25	2.01 ± 0.28	1.98 ± 0.33
B - 64	1.84 ± 0.43	1.82 ± 0.48	2.09 ± 0.33	1.85 ± 0.25	1.81 ± 0.17	1.83 ± 0.25	1.94 ± 0.27
C - 83	1.66 ± 0.11	2.02 ± 0.75	1.98 ± 0.33	1.93 ± 0.27	1.76 ± 0.32	1.73 ± 0.33	1.84 ± 0.24
D - 145	1.78 ± 0.32	2.06 ± 0.48	1.89 ± 0.34	1.85 ± 0.37	1.89 ± 0.45	1.85 ± 0.32	1.78 ± 0.48
E - 231	2.0 ± 0.31	2.00 ± 0.55	2.17 ± 0.35	2.05 ± 0.20	2.09 ± 0.45	2.00 ± 0.31	2.16 ± 0.38
F - 426	1.92 ± 0.51	2.19 ± 0.24	1.97 ± 0.54	1.71 ± 0.49	1.81 ± 0.27	2.04 ± 0.58	1.97 ± 0.39
G - 751	2.26 ± 0.60(8)	2.98 ± .96(8)	3.18 ± 1.05(8)	3.57 ± 1.95(8)	3.04 ± 1.96(8)	3.19 ± 1.67(5)	3.07 ± 1.91(4)

(): Number of animals.
 Not indicated: 10 Animals.

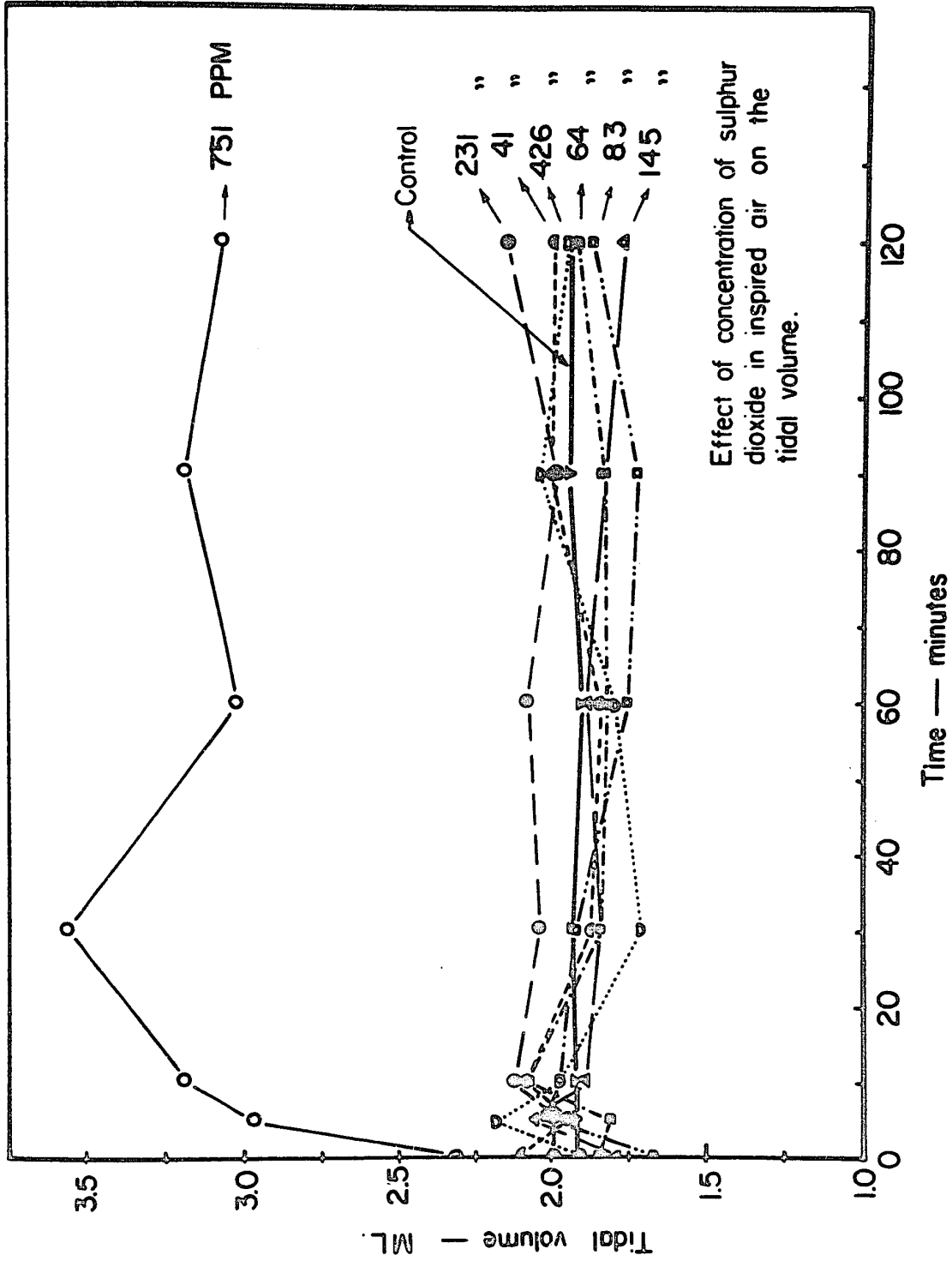

Effect of concentration of sulphur dioxide in inspired air on the tidal volume.

Fig. 3.6

Table 3.6. Analysis of Variance and Duncan's Test of the relationship between concentrations of sulphur dioxide, duration of exposure and tidal volume.

Source of Variation	Sum of Squares	Degrees of Freedom	Mean Square	F. Value
Total	2229	539		
Treatment	66.2	7	9.46	32.6**
Blocks	3.23	6	0.54	1.86
Residual	153.5	526	0.29	

Duncan's Test

(I) Concentration effect. G E A F B D O C

Any two means underscored by the same line are not significantly different.

----- 95%

----- 99%

Table 3.7. The values of mean minute volume with standard deviations of groups of rats exposed to different concentrations of sulphur dioxide.

Sulphur Dioxide Concn.	Time in Minutes						
	1	5	10	30	60	90	120
0	184.9 ± 45.8	182.3 ± 34.7	171.6 ± 24.3	176.9 ± 21.7	170.6 ± 28.8	177.7 ± 24.4	169.3 ± 28.9
A - 41	163.5 ± 40.0	135.0 ± 30.6	168.8 ± 46.9	159.9 ± 22.7	167.7 ± 33.7	187.5 ± 34.3	157.8 ± 34.4
B - 64	167.9 ± 42.5	159.6 ± 45.2	149.1 ± 23.8	263.1 ± 28.5	158.5 ± 25.4	152.2 ± 20.6	161.1 ± 31.5
C - 83	150.7 ± 39.4	144.3 ± 32.6	145.7 ± 22.8	160.9 ± 38.0	149.7 ± 27.0	144.8 ± 34.1	158.1 ± 28.6
D - 145	169.8 ± 43.8	146.3 ± 56.4	152.0 ± 44.6	145.2 ± 40.2	147.6 ± 44.2	137.1 ± 31.1	143.7 ± 43.1
E - 221	136.8 ± 38.0	146.0 ± 12.0	154.3 ± 11.9	132.9 ± 43.8	141.0 ± 28.3	150.0 ± 44.8	146.9 ± 32.1
F - 426	119.0 ± 29.9	125.8 ± 32.0	120.6 ± 35.9	130.9 ± 39.0	121.9 ± 26.5	133.1 ± 46.9	118.6 ± 41.4
G - 751	113.3 ± 76.8 ⁽⁸⁾	117.1 ± 12.2 ⁽⁸⁾	127.0 ± 17.9 ⁽⁸⁾	128.2 ± 38.4 ⁽⁸⁾	127.8 ± 29.7 ⁽⁸⁾	137.4 ± 20.4 ⁽⁵⁾	123.3 ± 15.9 ⁽⁴⁾

(): Number of animals.
 Note indicated: 10 Animals.

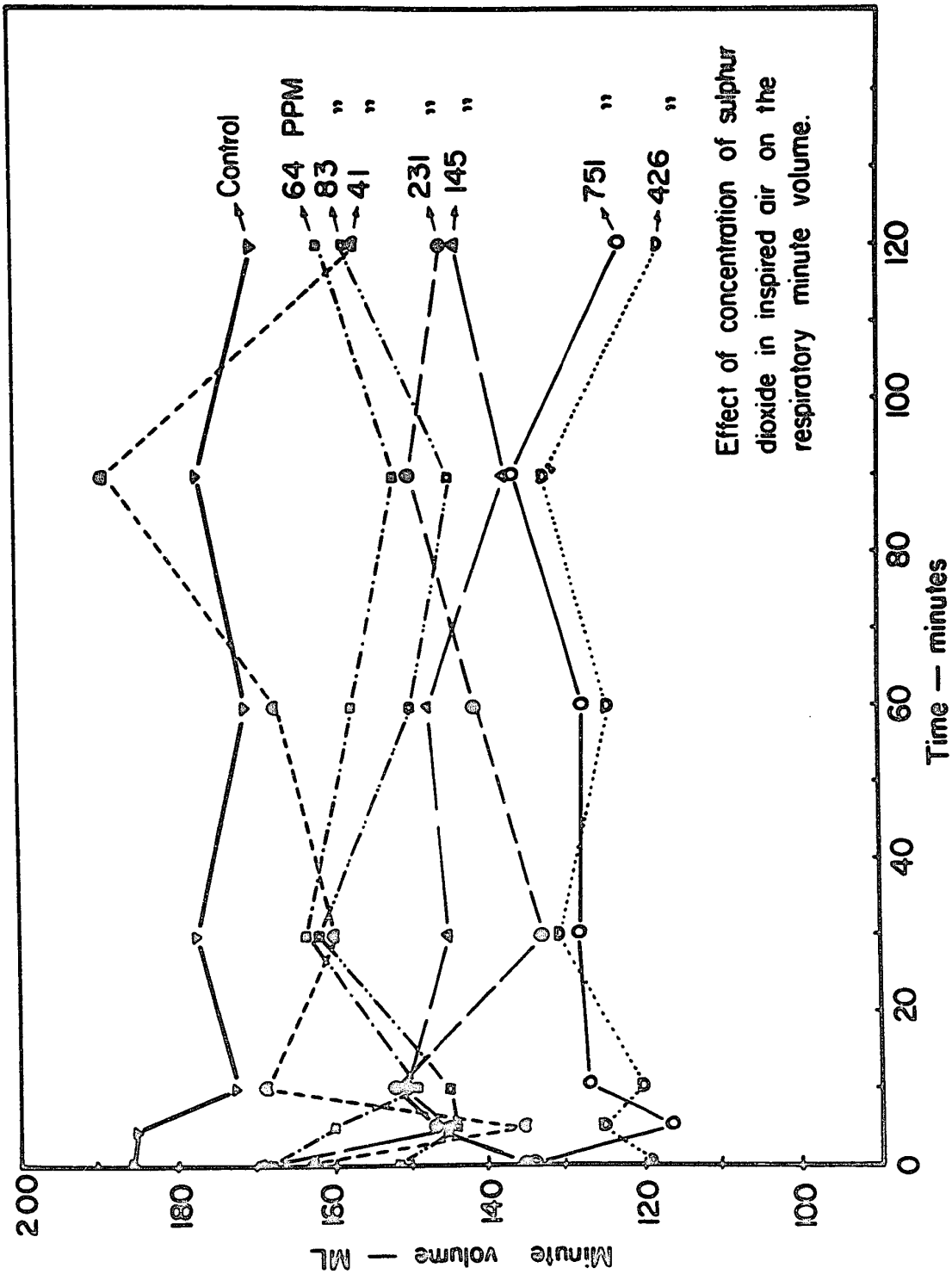

Effect of concentration of sulphur dioxide in inspired air on the respiratory minute volume.

Fig. 3.7

Table 3.8. Analysis of Variance and Duncan's Test of the relationship between concentrations of sulphur dioxide, duration of exposure and minute volume.

Source of Variation	Sum of Squares	Degrees of Freedom	Mean Square	F. Value
Total	770600	529		
Treatment	146538	7	20934	
Blocks	3100	6	5166	40.8**
Residual	620962	526	1181	

Duncan's Test

(I) Concentration effect. O A B C D E F G

Any two means underscored by the same line are not significantly different.

----- 95%

----- 99%

V. Histological Studies.

The most striking low power microscopic finding in the histological preparations was the positive correlation between the frequency of occurrence of pulmonary damage and the concentration of sulphur dioxide. For example, 70-80% of the lungs of rats exposed respectively to 426 and 751 p.p.m. of sulphur dioxide showed various degrees of pulmonary edema, whereas only 10-30% of the specimens from groups of animals exposed to the lower levels (60-200 p.p.m.) of the agent demonstrated similar types of lesion. On the other hand none of the lungs of the animals from the 40 p.p.m. and the control groups had observable adverse histological changes.

More detailed microscopic study (Fig. 3.8) showed that there was no correlation between severity of the injuries and sulphur dioxide concentration. The common pathological feature was the existence of moderate amounts of fluid in patches of alveoli. The walls of the alveoli were intact. The bronchioles were quite patent and the intact walls were occasionally covered with a thin layer of fluid. The mucosa of the bronchi were intact but they were frequently over-laid with mucous material. The blood vessels in the lungs of all groups of animals were normal. Finally, the lungs of the few animals that died during the inhalation exposure to 751 p.p.m. of sulphur dioxide were also examined. The pathological alteration in the alveoli, bronchioles and bronchi were essentially the same as those of the other groups except that the pulmonary vessels appeared to be slightly congested in some cases (Fig. 3.9).

Fig. 3.8. Photomicrograph (X125) of lung of a rat that survived 120 minutes of exposure to 426 p.p.m. of sulphur dioxide.

Fig. 3.9. Photomicrograph (X125) of lung of a rat that died after 30 minutes of exposure to 751 p.p.m. of sulphur dioxide.

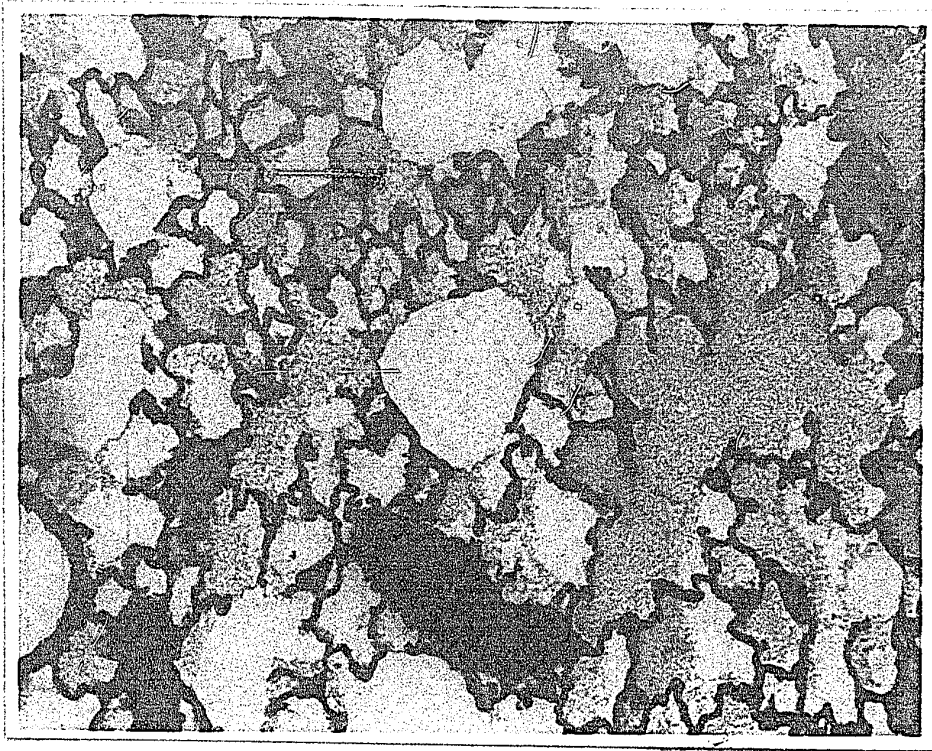

Fig. 3.8

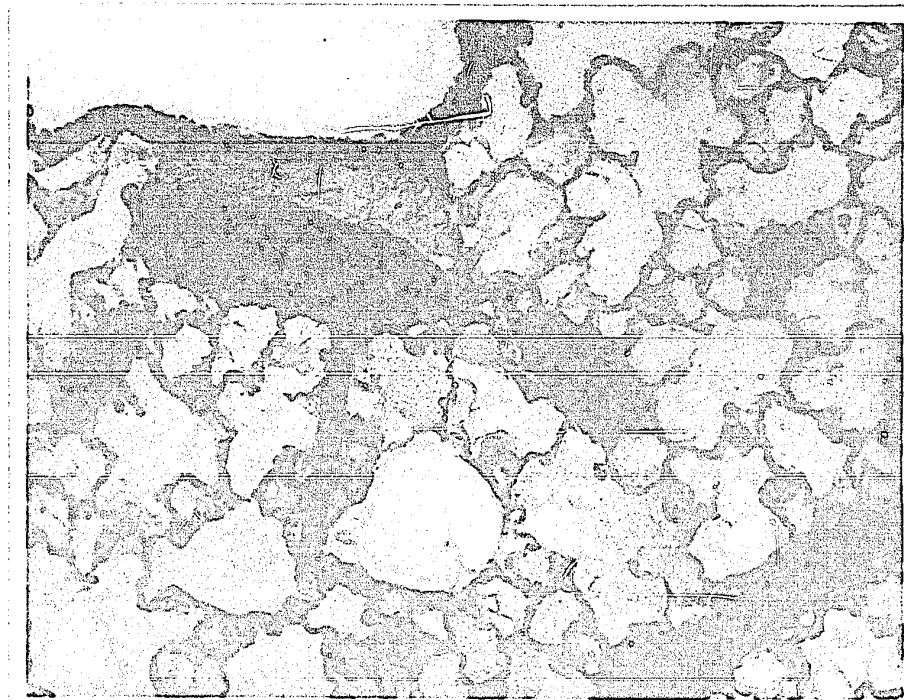

Fig. 3.9

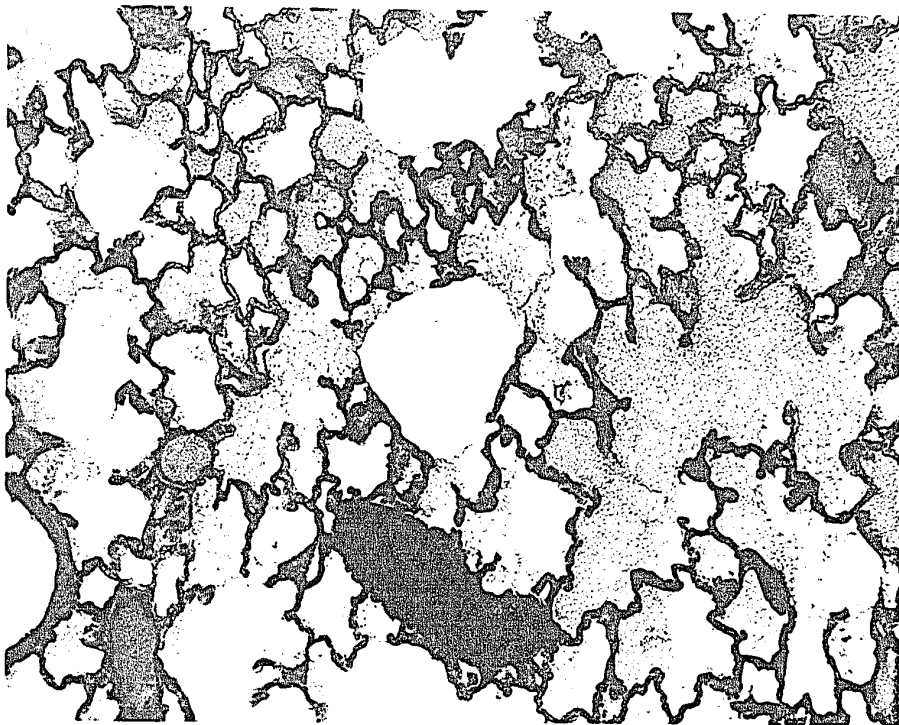

Fig. 3.8

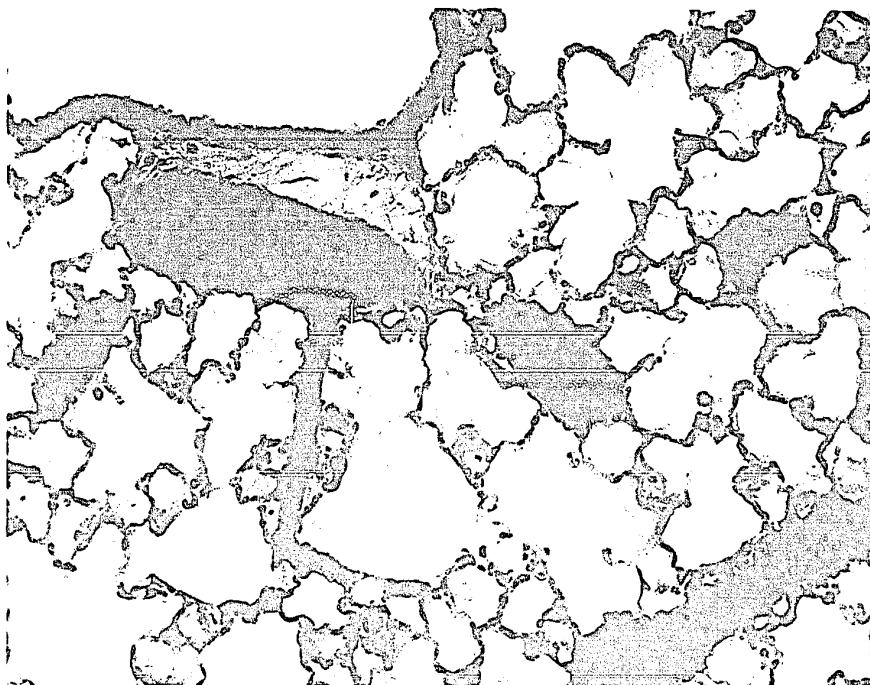

Fig. 3.9

VI. Discussion and Conclusions.

The respiratory system serves as the principal avenue for absorption into the body of gaseous agents from the atmosphere. The rate of respiratory uptake is one of the most important factors that determines the toxicity of an agent. It is necessary, therefore, to have an understanding of some of the factors such as concentration levels of the gas and respiratory dynamics which may influence the rate of uptake.

The results of the studies described above indicated that the concentration levels of sulphur dioxide in the inspired air influenced, to various degrees, the percent retention of the gas by the respiratory system and also affected the pulmonary dynamics.

Examination of the percent retention, α , (data in Table 3.1) revealed that the capacity of retaining sulphur dioxide by the respiratory tract of the experimental animal was inversely related to the concentration of the agent. When the values of the initial percent retention for all seven concentration levels (41 p.p.m. to 751 p.p.m.) were examined, the forms of concentration-retention curve (Fig. 3.10) suggested the existence of an exponential relationship. Assuming that the pulmonary response of the animals would follow the same mathematical function, attempts have been made to construct a theoretical retention-concentration curve extending further into the low gas concentration region. From the experimental data, a non-linear regression line of the following mathematical expression was obtained: $Y = 93.4 - 215 \log X$. This theoretical curve closely approximated the best experimental curve. Thus, the values for percent retention, α , in low

Fig. 3.10. Percent retention of sulphur dioxide by rats during the first minute of inhalation exposure to various concentrations of the agent.

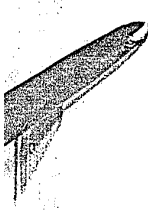

Fig. 3.11. Exponential percent retention of sulphur dioxide by rats during the first minute inhalation exposure to various concentrations of the agent.

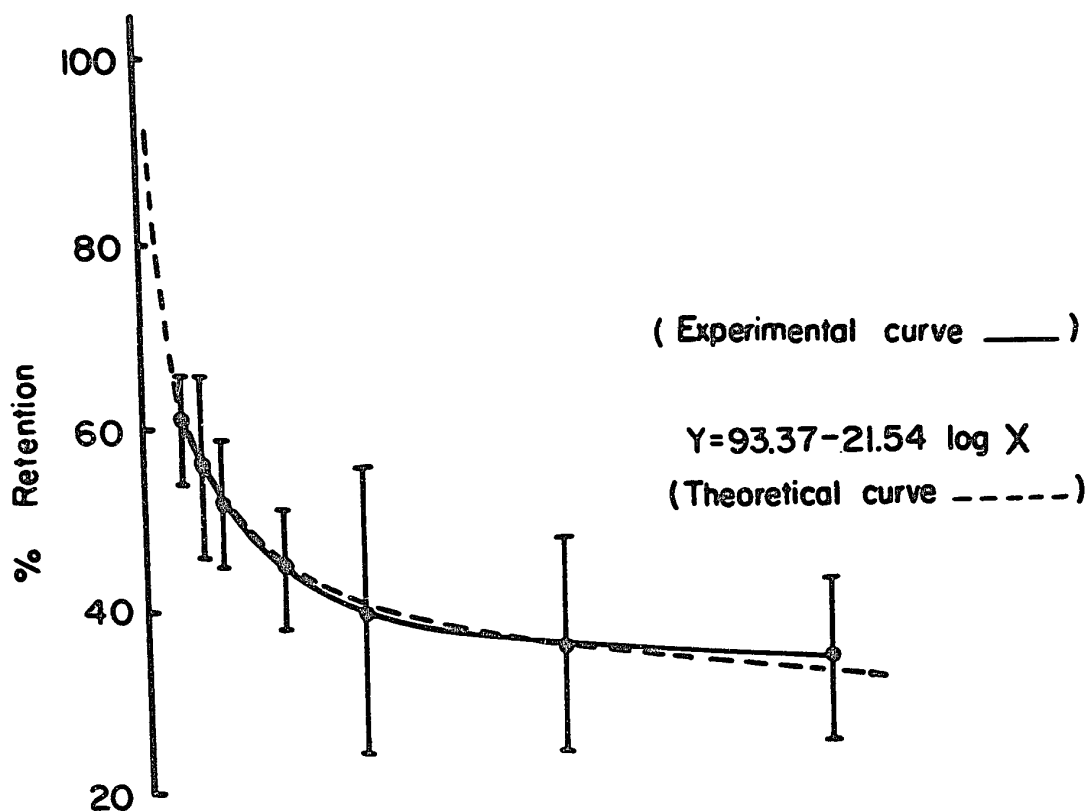

Fig. 3.10

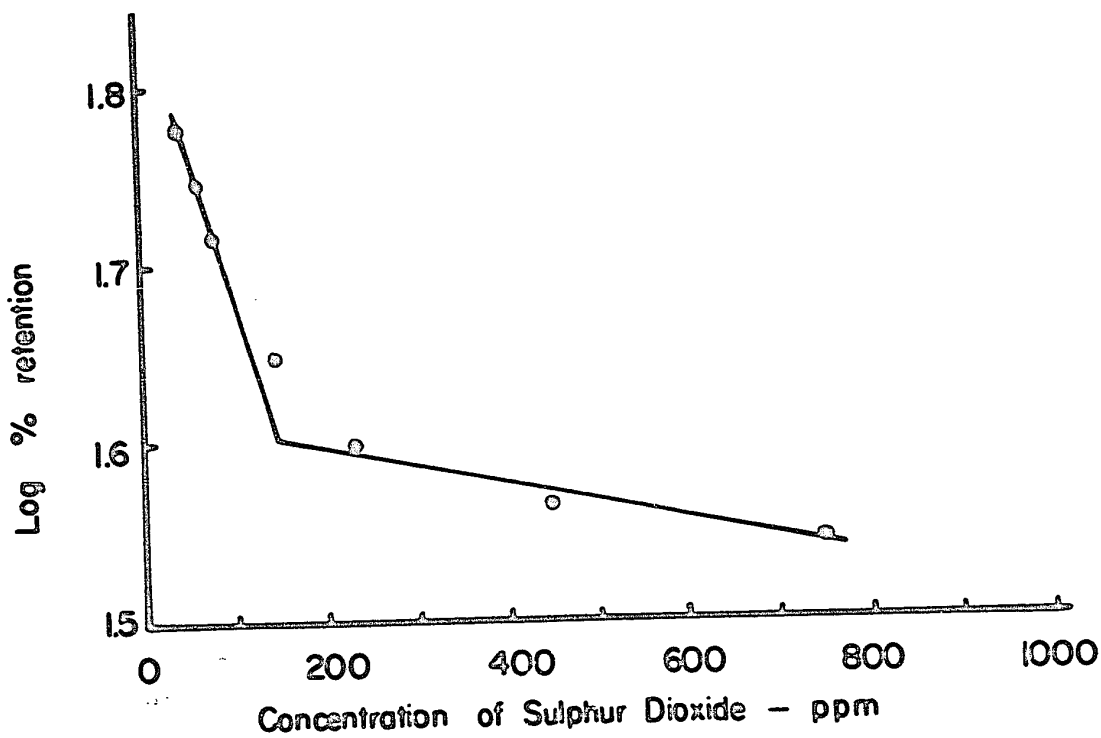

Fig. 3.11

concentrations could reasonable be estimated. The pulmonary retention of sulphur dioxide at near zero concentration was found, by this extrapolation, to be approximately equal to 94%. This estimate agreed closely with those reported by others who ventilated artificially the anaesthetized or surgically operated dog with low concentrations of sulphur dioxide. The range of sulphur dioxide concentration in those experiments was 6 - 150 p.p.m. and the values of α were found to vary between 82.5 to 98.5%. (88, 96, 97). However, each α value was obtained by analyzing the differences in sulphur dioxide level in an exhaled gas sample collected over a period of 40-60 minutes, while the method described in this presentation is capable of determining α continuously and practically instantaneously in a much smaller animal. The reason why the percent retention is not 100% even at the lowest sulphur dioxide concentration was obvious when respiration is visualized as a reciprocating process. The gas-laden air enters the respiratory tract through the nose and mouth and traverses the air passages into the lungs. In consequence of the intimate contact in the airway, a soluble gas such as sulphur dioxide should be extracted almost completely by the tissues in the upper respiratory tract. Thus, the gas concentration in the air arriving in the lungs would be much lower in relation to the inspired concentration. In the lungs the gas concentration would be further lowered by diffusion and absorption. On expiration, a reverse extraction of dissolved gas from the upper respiratory tract would occur. The total expired air would have an average gas concentration weighted according to

the relative air volumes from the lungs and from the respiratory tract, their respective gas concentrations and the amount of gas washed out.

Further examination of the α -concentration curve revealed the existence of more than one phase of pulmonary response to the inhalation of different concentrations of sulphur dioxide. The initial percent retention was observed to be as high as 60% at a concentration of 41 p.p.m. However, this retention dropped rapidly to 44% when the gas concentration was elevated to 145 p.p.m. On the other hand, α decreased slightly to 39% when the level of the agent was increased to 231 p.p.m. Further increase of sulphur dioxide concentration to 751 p.p.m. brought the value of α down merely to 34%. Statistical analysis (Table 3.1) indicated that the values of α for low (41, 64 and 83 p.p.m.) and high (145, 231, 426 and 751 p.p.m.) concentrations were significantly different at the 99% level of probability (Table 3.2). Since the general form of the retention-concentration curve suggested an exponential function, the data were replotted on semi-logarithmic co-ordinates, on which exponential functions should be linear. By a process of successive approximation the curve was separated into two components (Fig. 3.11). This suggested the existence of two distinct mechanisms in the pulmonary system concerning the alteration of percent retention with respect to sulphur dioxide concentration in the inspired air.

The first mechanism operated only at low sulphur dioxide level (0.80 p.p.m.), and could be described as a fast, physiological

reflex response. It has been well established that the immediate responses of the pulmonary system to an irritant gas were an increase of non-elastic pulmonary resistance and a decrease in the compliance of the lungs⁽¹⁰³⁾. The causes were considered to be either a direct, local effect on the bronchiolar smooth muscle or a stimulation of afferent nerve endings with consequent reflex broncho-constriction. Since the magnitude of retention of a gas depends considerably on the area of the absorptive surface and the efficiency of the mixing of gas in the air spaces within the respiratory tract, it was, therefore, reasonable to say that the initial rapid decrease in \bar{C} was a result of a rapid modification of the absorptive condition within the respiratory tract. In addition, it was reported that the magnitude of modification of pulmonary air-flow resistance and compliance was generally associated with the concentration of sulphur dioxide (96,97,103). Careful examination of the data revealed that the alteration of pulmonary air flow resistance with respect to the gas concentrations followed a similar trend of response, as indicated by an initial rapid phase and a subsequent slow phase. This speculation implied that the modification of \bar{C} may indeed be a result of the changes in the respiratory tract.

The second mechanism, which was operative at high concentration of sulphur dioxide, could be ascribed to a slow pathological response. At this stage, in addition to the maximum physiological response, the intervention of pathological changes became more prominent⁽¹⁰⁴⁾. As the broncho-secretion and pulmonary edema

progressed as sulphur dioxide concentration and duration of exposure increased, the absorptive processes of gases would be interfered with to an increasing extent. Consequently, the percent retention of the gas would be lowered correspondingly.

Histological studies provided pertinent support to the above suggestions. It was observed that over 80% of the lung specimens from rats undergoing inhalation exposure to high concentrations (426 to 751 p.p.m.) of the irritant showed various degrees of pulmonary edema (Fig. 3.8). On the other hand, there was no pathological condition seen in the lungs of rats exposed to 40 p.p.m. of the gas.

These processes also provide an explanation for the gradual diminution of Q with respect to the duration of inhalation exposure to a single level of sulphur dioxide. Statistical analysis indicated that Q values for the time intervals zero to one minute, 10 to 30 minutes and 90-120 minutes were significantly different from one another at the 99% level of probability (page 63).

The recognition of the alteration of Q when the concentration of the agent or the duration of the exposure is changed renders it necessary to re-examine the use of the Ct product or dosimetric expressions in describing the results of inhalation trials. Determination of the relationship between Ct and mortality constitutes a basic procedure when comparing the relative toxicities of gaseous agents. However, there is a considerable difference between Ct (mean concentration X time) and the actual dose retained because of the modifications which have been shown to occur in

various physiological parameters. Consequently, the dosimetric technique was developed to include a respiratory term V (the minute volume) and a factor α (percent retention). This factor α has been shown to vary in accordance with the physical and chemical properties of the agent^(65,66,67) and among various animal species^(62,63,64). However, it has been considered to be constant for a given chemical and for a given species⁽⁶⁰⁾. The observations of the present investigation indicate that correction factors for concentration levels and duration of exposure must be considered when a wide range of concentration of an agent is employed in an experiment.

The effect of sulphur dioxide on the respiratory rate of the experimental animals was examined (Table 3.3). It was noted that the respiratory rates of the experimental animals at all concentration levels were lower than that of the control animal. At zero p.p.m., the average respiratory rate was 102 \pm 5 respiration per minute. This value dropped progressively to approximately 50% of the initial value when the gas concentration was increased to 751 p.p.m. Statistical analysis showed that the respiratory rate of control animals, animals exposed to medium (40-426 p.p.m.) and high (751 p.p.m.) levels of sulphur dioxide were significantly different at the 99% level of probability (Table 3.4). In addition, the gas seemed to exert a depressing influence on the respiratory rate of all groups of animals during the first ten minutes of the exposure. Beyond this critical period, the respiratory rates resumed their respective initial levels and remained there until the termination of the experiments. However, when each experimental

group was examined individually, the analysis showed that the modifications in respiratory rates were significantly different only in rats exposed to low levels of the irritant (41-63 p.p.m.). The slight reduction in respiratory rate in control animals was not significant because such response was merely an adaptation reaction of the animal to the new atmosphere of air supply. On the other hand, the significant depression of this parameter, which resulted from exposure to low concentrations of sulphur dioxide, was probably caused synergistically by the sudden change of atmosphere and the reflex response of the relatively undamaged pulmonary tissues to the highly irritating gas. However, when animals were exposed to higher concentrations, they tended to breathe more slowly according to their individual tolerances. Consequently, the depressing effect on the already reduced respiratory rate became relatively insignificant.

While changes in the concentration of sulphur dioxide influenced both percent retention and respiratory rate, the respiratory tidal volume was relatively unaffected (Table 3.5). The respiratory tidal volume of groups of animals exposed to 40-426 p.p.m. of sulphur dioxide did not differ significantly from that of the control animals, except when animals were subjected to very high levels (751 p.p.m.) of the agent did the increase in tidal air become highly significant (Table 3.6). This increase in tidal air was accompanied by a significant reduction in respiratory rate, as has been previously described. At this stage the respiration of a few of the animals was obviously becoming very difficult. Several experimental animals died, probably as a result of respiratory

failure. Histological examination of the lung tissues revealed that the two animals which succumbed early in this trial showed no pathological lesion, while the remaining four of the six rats which died later exhibited various degrees of pulmonary edema, in no case severe enough to account for the death of the animals (Fig. 3.9). On the other hand, the presence of mild pulmonary vascular congestion suggested that cardiac insufficiency might also be a factor contributing to the death of the animals. Based upon our previous experience⁽⁸⁵⁾, these few exceptional animals might be considered as "sensitive" individuals.

Respiratory minute volume is one of the parameters which must be employed in the calculation of \bar{A} , the percent retention. There was some evidence of modification of minute volumes by different concentrations of sulphur dioxide (Fig. 3.7). The average value for control animals was approximately 170 millilitres per minute which was not significantly higher than those of the experimental animals (Table 3.8) at the 99% level of probability. However, at the 95% level of probability, there were significant differences between the minute volumes of low (0-291 p.p.m.) and high (426-751 p.p.m.) gas concentration groups. When respiratory minute volume, respiratory rate and tidal volume were examined together, it was evident that the depression of minute volume was caused primarily by a depression of respiratory rate in spite of an observable elevation of tidal volume. Further statistical analysis of the minute volume data confirmed that duration of exposure did not exert an appreciable influence on this parameter in all cases.

Finally, comparison of the ventilatory data of the control animals in the earlier studies (page 21) and the present investigation was made. It was interesting to note that the value of mean respiratory rate of the second group of animals was not significantly lower than that of the former group, whereas the mean tidal volume, on the contrary, was significantly higher. The result of the changes in the relationship between these two respiratory parameters in the second group of animals was an increase in the minute volume. However, the increase was not significant at the 95% level of probability. The explanation for these discrepancies lies in the fact that the ventilatory data of the second group were obtained at specified time-points irrespective of the state of the animals, whereas the same data for the former control animals were taken only when the animals were in a state of relaxation.

Thus far, we have shown the intimate relationship between the concentration of sulphur dioxide and the percent retention, α , and the pulmonary dynamics of experimental animals. The alteration of α is caused primarily by changes induced in the condition of the pulmonary system. We have distinguished two mechanisms of alteration of the pulmonary responses to different concentrations of sulphur dioxide. The first mechanism, which operates at low sulphur dioxide concentrations, is a fast, physiological reflex response of the pulmonary tissues to the irritant; the second mechanism assumes importance at high levels of the agent and it is a combination of the first response and a slowly developing pathological change. In regard to pulmonary dynamics, we have

also observed two stages of response: the primary reaction of animals exposed to increasing concentrations of sulphur dioxide is a progressive depression of respiratory rate with a relatively constant tidal volume and a consequently lowered minute volume; the second stage is an elevation of the tidal volume while the respiratory rate remains depressed.

In conclusion, new techniques have been developed which permit the estimation of the retained dose of an inhaled toxicant and the characterization of the respiratory responses of the animal during the course of exposure. In this manner, a more accurate determination of the relationship between dose and biological response has been rendered possible.

BIBLIOGRAPHY

1. Oberst, F. W.
Factors Affecting Inhalation and Retention of Toxic Vapours
in Inhaled Particles and Vapours, edited by Davis, C. N.
Symposium Publication Division, Pergamon Press, page 252, 1961.
2. Kleiber, M.
University of California Publications in Physiology 8, 207, 1943.
3. The Personnel of U. S. Navy Medical Research Unit No. 1 and
Kleiber, M.
Science, 99, 542, 1944.
4. Fenning, C. F.
Lab. and Clin. Med. 22, 1279, 1937.
5. Schaefer, H., E. Bleicher, and F. Eckervogt, F.
Arch. Ges. Physiol. 251, 491, 1949.
6. Goldenschn, E. S. and L. Zablou.
J. Appl. Physiol. 14, 463, 1959.
7. Moore, R., E. B. Sigg and J. A. Schneider.
J. Appl. Physiol. 11, 488, 1957.
8. Ekberg, D. R. and H. E. Hance.
J. Appl. Physiol. 15, 321, 1960.
9. Chapin, J. L.
Am. J. Physiol. 179, 146, 1954.
10. Andur, M. O. and J. Mead.
Am. J. Physiol. 192, 364, 1958.
11. Adolph, E. F. and A. P. Hoy,
J. Appl. Physiol. 15, 6, 1960.
12. Gottlieb, S. F., and R. V. Jagodzinski.
Federation Proc. 20, 420, 1961.
13. Gottlieb, S. F. and R. V. Jagodzinski.
J. Appl. Physiol. 17, 576, 1962.
14. Jackson, D. E.
Experimental Pharmacology and Materia Medica, page 201.
The C. V. Mosby Company, St. Louis, 1939.

15. Guyton, A. C.
Am. J. Physiol. 150, 70, 1957.
16. Ainsworth, M. and T. W. N. Truckle.
Porton Technical Paper No. 244, 1951.
17. Leosli, C. G., O. H. Robertson and T. T. Fack.
J. Inf. Dis. 72, 142, 1943.
18. Reichert, P. and H. Roth.
J. Lab. and Clin. Med. 25, 1091, 1940.
19. Vacuum Tube Amplifiers, page 80.
Edited by Vallet, G. E. Jr., and H. Wallman McGraw, 1948.
20. Bert, P.
Respiration, Paris. Baillere, 1870.
21. Handbook of Biological Data, page 175.
Edited by Spector, W. S., Saunders, 1956.
22. Adolph, E. F.
Science 109, 579, 1949.
23. Jackson, C. M.
Am. J. Anat. 15, 61, 1913-14.
24. Holmes, J. A., E. C. Franklin and R. A. Gould.
U. S. Bur. Mines Bull. 98, 1915.
25. Jacobs, H. B.
Analytical Chemistry of Industrial Poisons, Hazards and Solvents.
2nd. ed. page 758, 1949.
Interscience, New York.
26. Sweeney, O. R., H. E. Outcault and J. R. Withrow.
Ind. Eng. Chem. 9, 949, 1917.
27. Berl, E.
Chem. Ztg. 45, 693, 1921.
28. Ries, E. F. and L. E. Clark.
Ind. Eng. Chem. 18, 747, 1926.
29. Johnstone, H. F.
Ind. Eng. Chem. 23, 620, 1931.
30. Anford, D. W. E. and Sugchen, T. M.
J. Chem. Soc. 3, 901, 1946.

31. Flint, D. J.
J. Soc. Chem. Ind. (London) 67, 2, 1948.
32. Monnett, O., G. St. J. Perrott and H. W. Clark.
U. S. Bur. Mines Bull. 254, 1, 1926.
33. McKay, R. J. and D. E. Ackerman.
Ind. Eng. Chem. 20, 538, 1928.
34. Kozlyaeva, T. N.
Zhur. Anal. Khim. 4, 75, 1949.
35. Atkin, S.
Anal. Chem. 22, 947, 1950.
36. Urone, P. E. and W. E. Boggs.
Anal. Chem. 23, 1517, 1951.
37. West, P. W. and G. C. Gaeke.
Anal. Chem. 28, 1816, 1956.
38. Coste, J. H. and G. B. Courtier.
Trans. Faraday Soc. 22, 1198, 1936.
39. Francis, W., M. C. Morley and E. W. Gillham.
J. Soc. Chem. Ind. (London) 57, 419, 1938.
40. Greenwood, H. D.
Ind. Chemist 15, 113, 1939.
41. Gillham, E. W. F.
J. Soc. Chem. Ind. 65, 370, 1946.
42. Thomas, M. D. and R. J. Cross.
Ind. Eng. Chem. 20, 645, 1928.
43. Smith, R. B. and B. S. T. Fris.
J. Ind. Hyg. 18, 338, 1931.
44. Katz, M.
Anal. Chem. 22, 1040, 1950.
45. Adams, D. F., H. J. Dana and E. K. Koppe, Bulletin 907,
Community Air Pollution Program, U. S. Public Health Service,
Cincinnati, Ohio, Sept. 1957.
46. Cummings, W. G. and M. W. Redfearn.
J. Inst. of Fuel 30, 628, 1957.
47. Helwig, H. L. and C. L. Gordon.
Anal. Chem. 30, 1810, 1958.

48. Welch, A. F. and J. P. Terry.
J. Ind. Hyg. 21, 316, 1960.
49. Thomas, M. D. and J. N. Abersold.
Ind. Eng. Chem. 1, 14, 1929.
50. Thomas, M. D.
Ind. Eng. Chem. 4, 253, 1932.
51. Thomas, M. D., J. O. Ivie, J. N. Abersold and R. H. Hendricks.
Ind. Eng. Chem. 15, 287, 1943.
52. Thomas, M. D. and J. O. Ivie.
Ind. Eng. Chem. 18, 383, 1946.
53. Perley, G. A. and B. F. T. Langsdorf.
Air Pollution, page 556.
McGraw-Hill Book Company, Inc., New York, 1952.
54. Nash, T.
J. Scient. Instr. 38, 48, 1961.
55. Washburn, H. W. and R. R. Austin.
Air Pollution, page 596.
McGraw-Hill Book Company, Inc., New York, 1952.
56. Carpenter, S. B. and R. E. Sparkman.
J. Air Pollution, Control Assoc. 5, 195, 1956.
57. McKee, H. G. and W. L. Rolliwitz.
J. Air Pollution, Control Assoc. 8, 338, 1959.
58. Haber, R.
Fünf Vortrage Ausden Jahran, 920-23 No. 3, Die Chemie in
Kriege H. 5 Zur Geschichte des Gaskampfes. Julius Springer,
Berlin, 1924.
59. Jacobson, K. H., F. W. Oberst, M. K. Christensen, Jr.,
J. A. Dearmon.
Arch. Ind. Hlth. 19, 5, 1959.
60. Weston, R. E. and L. Karel.
J. Pharm. Exp. Therap. 88, 195, 1946.
61. Oberst, F. W., R. S. Ross, M. K. Christensen, J. W. Crook,
P. Cresthull and C. W. Umland.
Military Med. 119, 377, 1956.
62. Carneron, G. R., J. H. Gaddum and R. D. H. Short.
J. Path. Bact. 58, 449, 1946.

63. Lanchahl, H. E. and R. G. Herrmann.
Arch. Ind. Hyg. Occup. Med. 1, 36, 1950.
64. Ainsworth, M. and R. Shephard.
Inhaled Particles and Vapours, page 233, edited by Davis, C. N.
Pergamon Press, Inc., 1961.
65. Cander, L.
J. Appl. Physiol. 14, 538, 1959.
66. Cander, L. and R. E. Forster.
J. Appl. Physiol. 14, 541, 1959.
67. Hatch, T. F. and H. Swan.
Inhaled Particles and Vapours, page 267, edited by Davis, C. N.
Pergamon Press, Inc., 1961.
68. Pincus, S. and A. C. Stern.
Am. J. Pub. Hlth. 27, 321, 1937.
69. Katz, M.
Publ. Hlth. Report (U.S.) 67, 664, 1952.
70. Air Pollution in Donora, Pa.
Publ. Hlth. Bull. No. 306, Federal Security Agency, Public
Health Service, 1949.
71. Logan, W. F. D.
Lancet 264, 336, 1953.
72. Drinker, P.
Arch. Ind. Hyg. Occup. Med. 9, 247, 1954.
73. Committee on Threshold Limits.
American Conference of Governmental Industrial Hygienists:
Threshold Limit Values for 1958.
Arch. Env. Hlth. 7, 592, 1963.
74. Henderson, Y. and H. W. Haggard.
Noxious Gases and the Principle of Respiration Influencing
their Action, page 130, Reinhold Publishing Corp., 1949.
75. Kehoe, R. A. W. F. Machle, K. Kitzmiller and T. J. LeBlanc.
J. Ind. Hyg. 14, 159, 1932.
76. Greenwald, I.
Arch. Ind. Hyg. Occup. Med. 10, 455, 1954.
77. Volkova, N. V.
Tr. Leningradsk. Sanit. gig. Med. Inst. 26, 59, 1956.

78. Prokhorav, Y. D., A. A. Rogov.
Gigiena i Sanitarila 24, 22, 1959.
79. Sugawara, K.
Igaku Kenkyu 28, 1225, 1958.
80. Ball, C. O. T., R. M. Heyszel, O. J. Balchum, G. O. Elliott
and G. R. Menseely.
Physiologist 2, 15 (Aug.) 1960.
81. Weedon, F. R., A. Hartzell and C. Setterstrom.
Contrib. Boyce Thompson Inst. 10, 281, 1939.
82. Weedon, F. R., A. Hartzell and C. Setterstrom.
Contrib. Boyce Thompson Inst. 11, 365, 1940.
83. Pottle, R. B. and H. Cullumbine.
Brit. Med. J. 2, 913, 1956.
84. Salem, H. and H. Cullumbine.
Arch. Env. Hlth. 2, 641, 1961.
85. Leong, K. J., H. N. MacFarland, E. A. Sellers.
Arch. Env. Hlth. 3, 668, 1961.
86. Widdicombe, J. G.
Am. J. Physiol. 123, 55, 1954.
87. Widdicombe, J. G.
Am. J. Physiol. 123, 71, 1954.
88. Salem, H. and D. M. Aviado.
Arch. Env. Hlth. 2, 656, 1961.
89. Amdur, M. O.
Am. Ind. Hyg. Assoc. Quart. 18, 149, 1957.
90. Amdur, M. O.
Int. J. Air Poll. 1, 170, 1959.
91. Balchum, O. J., J. Dybicki and G. Menseely.
Fed. Prov. 18, 6, 1959.
92. Amdur, M. O., H. W. Melvin and F. Drinker.
Lancet 265, 758, 1953.
93. Lawther, F. J.
Lancet 262, 745, 1955.
94. Frank, H. R., M. O. Amdur, J. Forchester and J. L. Whittenberger.
J. Appl. Physiol. 17, 252, 1962.

78. Prokhorov, Y. D., A. A. Rogov.
Gigiena i Sanitarila 24, 22, 1959.
79. Sugawara, K.
Igaku Kenkyu 28, 1225, 1958.
80. Ball, C. O. T., R. M. Heyssel, O. J. Balchum, G. O. Elliott
and G. R. Menseely.
Physiologist 2, 15 (Aug.) 1960.
81. Weedon, F. R., A. Hartzell and C. Setterstrom.
Contrib. Boyce Thompson Inst. 10, 281, 1939.
82. Weedon, F. R., A. Hartzell and C. Setterstrom.
Contrib. Boyce Thompson Inst. 11, 365, 1940.
83. Pottle, R. B. and H. Cullumbine.
Brit. Med. J. 2, 913, 1956.
84. Salem, H. and H. Cullumbine.
Arch. Env. Hlth. 2, 641, 1961.
85. Leong, K. J., H. N. MacFarland, E. A. Sellers.
Arch. Env. Hlth. 2, 668, 1961.
86. Widdicombe, J. G.
Am. J. Physiol. 123, 55, 1954.
87. Widdicombe, J. G.
Am. J. Physiol. 123, 71, 1954.
88. Salem, H. and D. M. Aviado.
Arch. Env. Hlth. 2, 656, 1961.
89. Amdur, M. O.
Am. Ind. Hyg. Assoc. Quart. 18, 149, 1957.
90. Amdur, M. O.
Int. J. Air Poll. 1, 170, 1959.
91. Balchum, O. J., J. Dybicki and G. Menseely.
Fed. Prov. 18, 6, 1959.
92. Amdur, M. O., M. W. Melvin and F. Drinker.
Lancet 265, 758, 1953.
93. Leather, F. J.
Lancet 269, 745, 1955.
94. Frank, M. R., M. O. Amdur, J. Worchester and J. L. Whittenberger.
J. Appl. Physiol. 17, 252, 1962.

95. Thompson, J. R. and D. M. Pace.
Can. J. Biochem. and Physiol. 40, 207, 1962.
96. Balchum, O. J., J. Dybicki and G. R. Meneely.
Am. J. Physiol. 197, 1417, 1959.
97. Balchum, O. J., J. Dybicki and G. R. Meneely.
Am. J. Physiol. 15, 62, 1960.
98. Leong, K. J., G. F. Dowd, H. N. MacFarland.
Can. J. Physiol. & Pharmacol. 42, 189, 1964.
99. Leong, K. J., G. F. Dowd, H. N. MacFarland.
Am. Ind. Hyg. 1964 (in press).
100. Oberst, F. W.
Inhaled Particles and Vapours, Page 249, edited Davis, C. N.
Pergamon Press, Inc., 1961.
101. Steel, R. G. D. and J. H. Torrie.
Principle and Procedures of Statistics, page 132,
McGraw-Hill Book Company Inc., New York, 1960.
102. MacFarland, H. N. and K. J. Leong.
Arch. Env. Hlth. 4, 591, 1962.
103. Andur, M. O.
Inhaled Particles and Vapours, page 281, edited by Davis, C. N.
Pergamon Press, Inc., 1961.
104. Henderson, Y. and H. W. Haggard.
Noxious Gases and the Principle of Respiration Influencing
their Action, page 117, Reinhold Publishing Corp., 1943.