



National Library of Canada

Cataloguing Branch
Canadian Theses Division

Ottawa, Canada
K1A 0N4

Bibliothèque nationale du Canada

Direction du catalogage
Division des thèses canadiennes

NOTICE

The quality of this microfiche is heavily dependent upon the quality of the original thesis submitted for microfilming. Every effort has been made to ensure the highest quality of reproduction possible.

If pages are missing, contact the university which granted the degree.

Some pages may have indistinct print especially if the original pages were typed with a poor typewriter ribbon or if the university sent us a poor photocopy.

Previously copyrighted materials (journal articles, published tests, etc.) are not filmed.

Reproduction in full or in part of this film is governed by the Canadian Copyright Act, R.S.C. 1970, c. C-30. Please read the authorization forms which accompany this thesis.

**THIS DISSERTATION
HAS BEEN MICROFILMED
EXACTLY AS RECEIVED**

AVIS

La qualité de cette microfiche dépend grandement de la qualité de la thèse soumise au microfilmage. Nous avons tout fait pour assurer une qualité supérieure de reproduction.

S'il manque des pages, veuillez communiquer avec l'université qui a conféré le grade.

La qualité d'impression de certaines pages peut laisser à désirer, surtout si les pages originales ont été dactylographiées à l'aide d'un ruban usé ou si l'université nous a fait parvenir une photocopie de mauvaise qualité.

Les documents qui font déjà l'objet d'un droit d'auteur (articles de revue, examens publiés, etc.) ne sont pas microfilmés.

La reproduction, même partielle, de ce microfilm est soumise à la Loi canadienne sur le droit d'auteur, SRC 1970, c. C-30. Veuillez prendre connaissance des formules d'autorisation qui accompagnent cette thèse.

**LA THÈSE A ÉTÉ
MICROFILMÉE TELLE QUE
NOUS L'AVONS REÇUE**



UNIVERSITÉ D'OTTAWA
UNIVERSITY OF OTTAWA

EARTH PRESSURE CELLS TO MEASURE THE DISTRIBUTION

OF SHEAR AND NORMAL FORCES ON A FOOTING

by

J.P. Doohan

Submitted in partial fulfillment
of the requirements for the degree of
Master of Applied Science

Department of Civil Engineering

School of Graduate Studies

University of Ottawa

Ottawa, Canada

1975

PREFACE

A major project has been undertaken to determine the bearing capacity of strip footings on sand. As a part of this project the measurement of the distribution of shear and normal forces on the base of a footing is required. A footing has been constructed which incorporates earth pressure cells which can measure these forces.

An assessment was made of the types of earth pressure cells, all capable of measuring shear and normal forces or stresses. Cambridge cells were chosen for this application. These cells also allow the eccentricity of the normal force to be measured. A modified cambridge cell was manufactured for use in the footing. Six cambridge type cells were manufactured, calibrated and installed in a footing.

Successful measurements of shear and normal forces were made.

ACKNOWLEDGEMENTS

The author would like to express his gratitude to Professor D.H. Shields, under whose guidance this project was completed.

Financial assistance was provided by the N.R.C. under Grant No. A-7376, and is gratefully acknowledged.

Thanks are also due to Dr. G.E. Bauer and Dr. J.D. Scott of the University of Ottawa for their helpful suggestions and interest as well as other members of the university staff in particular, Mr. C. Lavigne and Mr. F. Argue. Mr. L. Weatherstone of the N.R.C. provided needed technical assistance and his help is acknowledged. Finally author wishes to thank Mrs. T.M. Fitzsimmons for her care and attention in typing.

TABLE OF CONTENTS

	<u>PAGE</u>
I INTRODUCTION	1
1.1 General	1
1.2 Requirements of the Present Study	1
II PRINCIPLES OF EARTH PRESSURE CELLS	2
2.1 General	2
2.2 Cell Types	2
(a) Diaphragm Cells	2
(i) Direct Acting	3
(ii) Indirect Acting	3
(iii) Counter Acting	4
(b) Rigid Face Plate Cells	5
2.3 Gauging Systems	6
(a) Mechanical Gauging Systems	6
(b) Hydraulic Gauging Systems	6
(c) Accoustic Gauging Systems	7
(d) Electrical Gauging Systems	7
III SHEAR AND NORMAL FORCE MEASUREMENT USING EARTH PRESSURE CELLS	8
3.1 General	8
3.2 Types of Combined Cells	9
3.2.1 Agarwal and Venkatesan	9
3.2.2 Telemetric Cells	10
3.2.3 Muhs Cell	11
3.2.4 Cambridge Cell	12
3.2.5 Other Scale Model Footings	13

	<u>PAGE</u>
3.3 Comments and Assessment	14
IV CAMBRIDGE TYPE CELLS	15
4.1 Principles of the Cambridge Cell	15
4.2 Design Requirements	16
4.3 Modifications to the Cambridge Cell	17
(a) Location of Shear Webs	17
(b) Number of Strain Gauges	18
4.4 Principle of Operation	18
4.5 Cell Material	19
4.6 Choice of Web Dimensions	20
4.6.1 Shear Web Thickness	21
4.6.2 Normal Web Dimensions	22
4.7 Gauging and Bridge Circuits	23
4.8 Output Voltages and Power Supplies	24
4.9 Recording Devices	26
4.10 Calibration Apparatus	27
4.11 Calibration Tests and Load Cell Constants	27
V INSTALLATION OF THE LOAD CELLS	32
5.1 Footing Description	32
5.2 Cell Mounting	33
5.3 Cell Face Plate Coating	34
VI TESTING OF FOOTING	35
6.1 Testing Apparatus	35
6.2 Test Procedure	36
6.3 Reduction of Observations	36
6.4 Results of Load Test	41
6.5 Conclusions	41

VII DISCUSSION AND CONCLUSIONS

7.1 Discussion

7.2 Conclusions

7.3 Suggestions for Further Research

PAGE

42

42

43

45

DESCRIPTION OF FIGURES AND TABLES

<u>FIGURE</u>	<u>DESCRIPTION</u>	<u>PAGE</u>
1	Schematic Agarwal and Venkatesan Cell	50
2	Translation of Active Face	51
3	Telemetric Pressure Cell Measuring Webs	52
4	Telemetric Cell Schematic	53
5	Schematic of Muhs Cell	54
6	Strain Gauges on Original Cambridge Cell	55
7	Strain Webs	56
8	Comparison of Cambridge and Modified Cell	57
9	Shear Bridge Circuit Wiring Diagram	58
10	Normal Bridge Circuit Wiring Diagram	59
11	Cell Terminal	60
12	Calibration Mount	61
13 to 17	Calibration Curves Cell Number 1	62 to 66
18 to 22	Calibration Curves Cell Number 2	67 to 71
23 to 27	Calibration Curves Cell Number 3	72 to 76
28 to 32	Calibration Curves Cell Number 4	77 to 81
33 to 37	Calibration Curves Cell Number 5	82 to 86
38 to 42	Calibration Curves Cell Number 6	87 to 91
43	Cell in Footing	92
44	Footing Base	93
45	Shear Versus Normal Stress Epoxy-Sand	94
46	Grain Size Curve	95
47	Normal Stress Versus Shear Angle	96

		<u>PAGE</u>
48	Calibration of Loading Jack	97
49 to 54	Load Test Results	98 to 103
55	Load Settlement Curve	104
56	Stress Distribution Across Footing	105

I INTRODUCTION

1.1 General

A large project has been undertaken at the University of Ottawa to examine the bearing capacity of strip footings on sand. As part of this project, the magnitude and the distribution of the contact stresses under the strip footing will be measured.

1.2 Requirements of the Present Study

The requirements of the present study include the design, fabrication and testing of a footing capable of measuring the reaction forces between the footing and the soil. These reaction forces are the shear and normal forces which act on the footing. These forces must be measured at a sufficient number of points so that their distribution over the face of the footing may be determined.

In the case of a strip footing, these requirements may be met by installing earth pressure cells across the breadth of the footing. The design and calibration of these cells forms the major part of the present study.

II PRINCIPLES OF EARTH PRESSURE CELLS

2.1 General

Earth pressure cells were used as long ago as 1916, as reported by Goldbeck and Smith (4), to measure lateral earth pressures on retaining walls. Since that time cells have been developed to measure pressures on walls, footings, and tunnel linings as well as pressures within an earth mass. Although there are hundreds of different pressure cell designs, all cells operate on one of a few basic principles. These principles will be described in the sections which follow.

2.2 Cell Types

There are two basic types of earth pressure cells. These are cells with a flexible surface or diaphragm in contact with the soil, and cells with a rigid face plate.

a. Diaphragm Cells:

Peattie and Sparrow (9) describe three basic diaphragm soil pressure cells.

(i) Direct Acting

In this type of cell the soil acts directly on a diaphragm which carries the gauging system. These cells require a sensitive gauging system since deflections of the diaphragm must be limited to $1/2000$ of the diameter (11) of the cell. Even so, shear forces acting in the plane of the diaphragm can affect reading of the normal forces. No successful way has been observed to utilize the diaphragm gauging system to measure the surface shear force. An auxillary measuring system is required to do this.

(ii) Indirect Acting

In a cell of this type the soil acts on a diaphragm which controls a fluid filled chamber. The fluid in the chamber acts in turn on a second pressure sensitive measuring diaphragm. Cells of this type have been known to give erroneous readings, particularly when the normal load does not act at the

centre of the cell face. These cells do, however, overcome the shear force problem outlined for type (i) cells but at the expense of making it impossible to measure the shear force without an auxillary system.

(iii) Counter Acting

In counter acting cells a fluid pressure is applied to the back of the diaphragm which is in contact with the soil to balance any soil pressure. Cells of this type require the pressure diaphragm to be moved a small distance against the soil mass thus measuring a passive pressure rather than the original active pressure acting on the cell. In general this countermovement will have a serious effect only in dense granular soils (11). Again, an auxillary measuring system is required if the surface shear force is to be measured.

b. Rigid Face Plate Cells

To overcome some of the problems associated with diaphragm pressure cells, for example arching the soil over the deflected surface of the diaphragm and the extreme sensitivity of the gauging required for a stiff diaphragm, rigid plate cells are sometimes used. The forces on the plate are measured usually by gauging small cross-section pillars which support the plate. As the rigid plate yields due to compression of the pillars, there will be relative movement of the edges of the plate with respect to the non yielding boundary. This may cause localized arching around the perimeter of the cell. This error will decrease in importance with increasing cell size. The error will also be minimized by keeping the pillars as stiff as possible.

Rigid face plate cells can also be instrumented to measure shear forces at the soil boundary. The distribution of shear stress over the surface of the face plate cannot be determined, however, at the present time.

2.3 Gauging Systems

It is possible at the present time to equip pressure cells with up to four basic gauging systems. These are:

a. Mechanical Gauging Systems

Mechanical gauging systems employ levers, extensometers, friction tapes and/or dial gauges. These gauging systems are crude and present difficulties in maintaining consistent results.

b. Hydraulic Gauging Systems

Hydraulic gauging systems include manometers and bourdon gauges, and have been used with all three basic types of diaphragm pressure cells to measure normal forces. A criticism of hydraulic systems is that relatively large volume changes are sometimes required to activate these systems. This implies either excessive diaphragm movements or excessive cell size. A modern solution to this problem is to use a sensitive pressure transducer which does not require much in the way of volume changes.

c. Accoustic Gauging Systems

The vibrating wire gauging system has been used widely with diaphragm gauges to measure normal forces. Earth pressures are transmitted to a diaphragm on the back of which are mounted two posts. A wire is stretched between the two posts so that diaphragm deflections result in changes in tension of the wire. These changes in tension can be detected if the wire is caused to vibrate by means of a plucking device. Temperature change effects can be overcome by matching the coefficients of thermal expansion of the wire and the diaphragm. Corrosion of the wire has been a problem in long term use of the system but has been overcome by the use of dried air or nitrogen in the cells.

d. Electrical Gauging Systems

Electrical resistance gauging systems are most popular when used with direct acting

diaphragm cells to measure normal forces and with rigid face plate cells to measure both normal and shear forces. Very small diaphragm deflections can be detected for example as they cause measurable changes in resistance in the strain gauge. Strain gauges can have long term reliability and are easily temperature compensated. Other electrical gauging systems that measure changes in capacitance or reluctance are in use.

III SHEAR AND NORMAL FORCE MEASUREMENT USING EARTH PRESSURE CELLS

3.1 General

It is conceivable that two types of cells could be used for any particular project; one to measure shear forces and the other to measure normal forces. However, this would mean that these forces would be measured at different locations. Relationships of shear to normal forces would have to be interpolated and would be influenced by variations in the homogeneity of the soil. Work by Muhs (8) has shown the necessity of using cells capable of measuring the shear and normal forces at the same point.

3.2 Types of Combined Cells

3.2.1 Agarwal and Venkatesan

Agarwal and Venkatesan (1) developed a simple cell to measure the shear and normal forces on deep foundations. This cell used a strain gauge equipped diaphragm to measure normal forces and a strain gauged cantilever arm to measure shear forces. A diagram of the basic operating principle is shown in figure 1, page 50.

Drawbacks of the cell developed by Agarwal and Venkatesan are:

- a. As the cantilever deflects while measuring shear forces the top plate translates, causing the normal force to act at a slight angle, producing and eccentricity of load (figure 2, page 51).
- b. The cell is also subject to what the inventors call "simultaneous action", where the normal force governs the zero reading on the gauge used to measure shear forces.

The cell was installed in a pile to measure the shear and normal forces as the pile was being driven. According to Agarwal and Venkatesan, the working principle is sound, and good performance should be expected in actual use.

3.2.2 Telemetric Cells

In a report on the state of telemetry in soil mechanics, Prange (10) states that a cell has been developed which will measure six load components on a single face. These loads are:

1. Normal force
2. Shear force in the X - direction
3. Shear force in the Y - direction
4. The moment about the x - axis caused by the eccentricity of the normal force.
5. The moment about the Y - axis caused by the eccentricity of the normal force.

6. The moment about the Z - axis caused by the eccentricity of the resultant shear forces. *

The telemetric cells employ strain gauges cemented to shear and normal stress webs as shown in figure 3 and 4 pages 52 and 53.

Output voltages are sent to a miniature coder and transmitter in the cells where the voltage is coded to a frequency and transmitted to the recording equipment.

The telemetric cells are intended to be used as embedded pressure cells but could possibly be used at a soil-structure boundary.

Telemetric cells are still in the development stage and further reduction in the size of the electronic parts is expected. The main disadvantage is the high cost associated with purchasing or manufacturing telemetric cells.

3.2.3 Muhs Cell .

Muhs (8) reports on the development of a cell to measure three components of a force. The cell uses a

complex system of ball bearings to separate any force into its three X, Y and Z components, which are then measured using strain gauges.

The cell consists of a thin walled inner cylinder equipped with strain gauges to measure the normal component of the force. The cylinder is mounted on a ball bearing platform which allows shear forces to be transmitted to shear measuring beams mounted around the cylinder. Ball bearings are also used between the cylinder and the beams to prevent the normal force affecting the shear force measurement figure 5, page 54, is a schematic diagram of the cell.

The cell was reported to have worked well for Muhs, both in a dry state and when submerged. However, the influence of the normal load acting eccentrically was not reported. It would appear to be difficult if not impossible to distinguish an eccentric normal force from the shear forces.

3.2.4 Cambridge Cell

The Cambridge cell was developed by Arthur and Roscoe (2) to measure normal and shear forces and the eccentricity of

the normal force in the direction of the shear force. The cell uses twenty foil strain gauges arranged into three full bridge circuits. The strain gauges are cemented to thin webs as shown in figure 6 page 55. A normal load causes strain in the normal webs and a shear load causes strain in the shear webs figure 7, page 56.

Eccentricity is calculated from the proportion of the normal load carried by each normal web.

The cell is fitted with a rigid top plate which can have a roughness, the same as the overall roughness of the boundary material in which it is to be installed. The range and sensitivity of the cell is determined by the thickness of the webs and by the area of the top plate.

3.2.5 Other Scale Model Footings

Hartikainen (6) reports that vertical and horizontal contact pressure distributions were measured using a 30 cm x 30 cm cell or footing. The footing contained 36 rigid face plates attached to strain gauged pillars for the measurement of vertical contact pressure. The eccentricity of the vertical pressure on the face plates could not be measured.

Shear or horizontal stresses were measured using 120 strain gauges cemented to a thin plate. Stresses in the plate were measured on a relative basis only, since the footing contained just one shear measuring plate. Hartikainen's footing was able to measure the horizontal and vertical contact pressures at a great number of points on the face of the footing, enabling a more comprehensive look at the stress distribution. Perimeter effects on a 30 cm x 30 cm footing should be a concern in this case as movement of the soil is not confined to one plane.

Hartikainen refers to the results of other model scale and some natural scale experiments. The earth pressure cells used in the other reported experiments were not capable of the simultaneous measurement of shear and normal forces, with exception of tests performed by Muhs using a cell described in subsection 3.2.3.

3.3 Comments and Assessment

While the four foregoing cells can measure shear and normal forces, it is felt that the Cambridge cell is best suited for the particular needs of the footing project.

The telemetric cells must be eliminated from consideration because of the high costs involved.

The Muhs cell was not adopted because of the complex moving parts and ball bearing arrangements.

In his recent book Hanna (1973) (5), compares the telemetric, Agarwal and Venkatesan, and Cambridge Cells. Hanna refers to the Cambridge Cell as the "ultimate in shear and normal force measurement".

Considering these factors it was decided to manufacture Cambridge type cells for use in the instrumentation of the footing.

IV CAMBRIDGE TYPE CELLS

4.1 Principles of the Cambridge Cell

The Cambridge cell is a rigid face plate cell supported by pillars or webs. It is usually made of aluminium. Strains are measured by means of electrical resistance gauges cemented to the webs.

4.2 Design Requirements

A footing 6 feet long by 1 foot wide will be used in the bearing capacity tests. The footing will stretch across the full width of the test facility - essentially a large sand box. The walls of the box will prevent movement of the soil in the direction parallel to the long direction of the footing. Thus the sand will be free to move only on a plane at right angles to the footing, simulating the infinitely long, strip footing case. Friction between the sand and the walls of the box will be minimized in a number of ways, but there will still be a discontinuity where the ends of the footing meet the walls of the box.

These end effects due to the tank walls will be eliminated for all intents and purposes by building the footing in three, 2 foot sections. Only the middle section, which will be well away from the sides of the box, will be instrumented with Cambridge cells.

To further ensure that the end effects will be eliminated, the cells will be located in a line across the middle of the centre section of the footing. The cells will also be kept narrow. This conflicts with the desire to have as

large a face plate on the cells as possible to minimize the edge effects discussed in Section 2.2. Therefore a reasonable compromise had to be made with the requirements for narrow cells and a necessity of having a reasonable number of cells across the width of the footing. It was decided that 6 cells would be used, each cell to have a face plate 1.5 by 2.0 inches (38.1 mm x 50.8 mm).

To minimize edge effects it was decided to limit deflection of the rigid face plate to less than 0.001 inches, as recommended by the United States Waterways Experimental Station (11).

It should also be realized that the full perimeter effect will be found only along the sides of the cells adjacent to the non-yielding surface of the footing. The other edges will be adjacent to the other cells which will also deflect. Only partial edge effects will arise in this case.

4.3 Modifications to the Cambridge Cell

a. Location of Shear Webs

The cell being used has four shear webs. The cell was machined to allow the shear webs to be as close as possible to the active face of the

cell. This differs from the original cell which has the shear forces transmitted through a shear pillar to only two shear webs. A comparison of the two cell types is shown in figure 8, page 57.

b. Number of Strain Gauges }

The modified cell uses twelve strain gauges, four in the shear circuit and four in each of the two normal circuits. The shear circuit is a full bridge circuit using four active gauges, two in tension and two in compression at any given time. The normal circuits are half bridge circuits using two active gauges and two dummy gauges.

4.4 Principle of Operation

The cell will measure a shear force S , a normal force N , and the eccentricity of the normal force e , in the plane of the shear force. As the force N is applied at a distance e , from the centre of the cell, it can be replaced by a force $N' = N$ at the centre and a moment $N \times e$. The force N' is balanced by reactions of $N'/4$ in each of the normal webs. The moment Ne results in forces in each pair of

normal webs, of equal magnitude but opposite sign and a force in the shear webs.

Similarly a shear force S can be replaced by a force S' in the shear webs and a moment caused by the fact that the actual force S acts slightly above the level of the shear webs. This moment is balanced by forces in each pair of normal webs which are equal but opposite in sign.

4.5 Cell Material

The cell was machined from a solid piece of aluminium alloy HS 15 W. Aluminium was used since it is easier to machine, and has a low modulus of elasticity. The modulus of elasticity was taken from the manufacturers specifications as being 107 pounds per square inch. A material with a low modulus of elasticity was chosen to provide that strians under load would be sufficiently large to be easily measured.

After machining the cells were boiled for about 15 minutes and then allowed to cool as recommended by Arthur and Roscoe (2). Boiling helps to clean the cells and reduce thermal stresses in the material which may have resulted from the machining process.

4.6 Choice of Web Dimensions

The dimensions of the web govern the range and sensitivity of the load cell. It should be noted that the minimum web thickness would be about 0.015 inches (0.381 mm) since machining thinner than this would be difficult. The webs were made 0.50 inches long and 0.25 inches wide (12.7 mm x 6.35 mm).

4.6.1 Shear Web Thickness

The maximum design shear stress was expected to be 10 tons/ ft.². If this load were distributed evenly over the cell face plate of area 3 in² the shear load per cell would be 416 pounds or 104 pounds for each of the 4 shear webs. The thickness, t of the webs would be found by:

$$t = \frac{104}{f_A \times b} \frac{lb}{lb/in^2 \times in} \quad 4.1$$

where f_A = allowable strength of aluminium
= 20,000 psi
b = width of web
= 0.25 in.

$$t = \frac{104}{20,000 \times 0.25} \quad 4.2$$
$$= 0.0208 \text{ in}$$

To check the web against buckling Euler's buckling formula was used.

$$P_{cr} = \frac{\pi^2 E b t^3}{3L^2} \frac{\frac{lb}{in^2} \times in \times in^3}{in^2} \quad 4.3$$

$$\text{or } t^3 = \frac{3 P_{cr} L^2}{\pi^2 E b} \quad 4.4$$

where E = modulus of elasticity 10⁷ psi

P_{cr} = critical buckling load

L = length of web

B = width of web

$$t^3 = \frac{3 \times 10^4 \times (.5)^2}{\pi^2 \times 10 \times .25} \quad 4.5$$

$$t = 0.0147 \text{ inches}$$

Therefore the thickness of the shear webs should be 0.0208 inches or .021 inches.

4.6.2 Normal Web Dimensions

As in the case of the shear webs, the normal webs have been designed for a load of 10 tons/ft² or 416 pounds per cell. However, due to eccentricity of the normal load it was felt that up to 75 percent of the total normal load could act on a pair of normal webs at any one time. It was therefore decided to allow the load per normal web to be 156 pounds which according to eqn 4.1 gives a thickness of:

$$t = \frac{156}{20,000 \times 0.25}$$

$$= 0.0312 \text{ inches}$$

Checking for buckling using eqn 4.4

$$t^3 = \frac{3 \times 156 \times (15)^2}{\pi^2 \times 107 \times 0.25}$$

$$= 0.0168 \text{ inches}$$

Therefore a thickness of 0.032 inches was chosen for the normal webs.

4.7 Gauging and Bridge Circuits

Each cell contains twelve SR-4 phenolic-glass foil strain gauges, temperature compensated for aluminium. The gauges were 0.5 x 0.25 inches. Gauges in cell number 1 had a gauge factor of 2.08 while all other gauges had a gauge factor of 2.10. The gauges were equipped with solder dots on the ends of the leads. It was thought that the solder dots would make wiring the circuits easier but this was not the case. It would not be recommended to order gauges equipped with solder dots again. The gauges were purchased from Balwin-Lima-Hamilton Electronics.

The strain gauges were placed on only one side of each of the shear and normal webs as compared with the original Cambridge cell which had strain gauges on both sides of the webs. Gauging of both sides was not necessary as the desired sensitivity was obtained using only one gauge per web. Eastman 910 adhesive was used and was found to be satisfactory. Great difficulty was encountered in soldering leads to the solder terminals on the gauges. It was found that only a single strand of small diameter wire could be attached to a dot. The

single strand was lead to a terminal to which standard size lead wires could be attached. The small diameter wire was a single strand of seven strand 30 gage copper wire.

The 12 strain gauges were arranged into three Wheatstone bridge circuits of four gauges each. The shear circuit used four active gauges, two in compression and two in tension wired as shown in figure 9, page 58. The two normal circuits contained four gauges each, two active gauges and two dummy gauges wired as shown in figure 10, page 59.

4.8 Output Voltages and Power Supplies

The strain gauges have a resistance of 120 ohms and a gauge factor of 2.10 or 2.08 and a maximum allowable current of 50 ma. The maximum voltage, V, that could be applied to the configuration shown in figure 9 is;

$$\begin{aligned} V &= 2 \times 120 \text{ ohms} \times 50 \text{ ma} \\ &= 12 \text{ volts} \end{aligned}$$

In order to work below the maximum allowable current of 50 ma, it was decided to use a 6 volt power supply. The supply used was made up of three 2.0 volt batteries each with a 40 amp - hr rating.

The expected output voltage can be estimated from

$$V_{out} = V_{in} \times G.F. \times \frac{L}{L} \times 10^3 \quad (4.6)$$

where V_{out} = output voltage in millivolts

V_{in} = input voltage in volts

G.F. = gauge factor

$\frac{L}{L}$ = strain

The maximum strain in the webs in shear was computed to be;

$$e = \frac{P}{EA} \quad (4.7)$$

where e = strain, in/in

P = force, pounds

E = modulus of Elasticity psi

$$= 10^7 \text{ psi}$$

A = area of web

$$E = \frac{104}{10^7 \times 0.25 \times 0.022}$$
$$= 1.89 \times 10^3 \text{ in/in}$$

Therefore, the maximum output shear voltage would be

$$V_{out} = 6.0 \times 1.89 \times 10^{-3} \times 2.1$$
$$= 23.8 \text{ millivolts}$$

The expected output voltage from the normal web circuits is governed by the expected strain. According to equation 4-7.

$$\begin{aligned} e &= \frac{P}{EA} \\ &= \frac{156}{10^7 \times 0.25 \times 0.032} \quad \frac{1b}{\frac{16}{in^2} \times in^2} \\ &= 1.95 \times 10^{-3} \text{ in/in} \end{aligned}$$

Giving an output voltage of

$$\begin{aligned} V_{out} &= 6.0 \times 1.95 \times 10^3 \times 2.1 \text{ volts} \times \frac{in}{in} \\ &= 24.5 \text{ millivolts} \end{aligned}$$

The bridge circuits in the cells will be supplied continuously with a 6 volt power source to stabilize the heating effects of the current through the gauges.

4.9

Recording Devices

Each cell is fitted with an eight lead terminal cemented to the base of the cell as shown in figure 11, page 60. Terminals one and two are the 6 volt supply voltage to the three bridge circuits. The other terminals are the outputs of the three bridge circuits. The output will be measured using a Kiethley Instruments Model 155 null detector microvoltmeter. The output is channelled through a switch and balance unit where a resistance is added to zero the output voltage at the no-load condition.

4.10 Calibration Apparatus

The cells were calibrated in a direct shear apparatus. Details of the stand are shown in figure 12, page 61. A shear load was applied manually and was measured on a 400 lb capacity load ring. The normal load was applied by means of a hanger and weights. Normal loads were applied at various eccentricities through a ball bearing which rested on a washer. The washer was used so that the ball bearing would not bend or dent the cell face plate. Arthur and Roscoe (2) showed that the load cell recorded the same load whether it was applied at a point through a steel ball or uniformly over the whole face of the cell.

4.11 Calibration Tests and Load Cell Constants

A method of calibrating the load cell was outlined by Arthur and Roscoe (2), where the applied load can be found from output voltages by a process of interaction. This method assumes that the sum of the outputs of the normal bridge circuits is directly proportional to the normal load. This assumption ~~is~~ probably slightly inaccurate due to differences, in the stiffnesses of the four webs, and gauge factors.

Another method of calibration was developed by Bozozuk (3) which assumes that the output voltages are linearly dependant on the three applied loads, i.e. the normal load, the shear load, and the moment due to eccentricity of the normal load. This assumption increases the accuracy over the method of interaction, and gives a matrix of coefficients or load cell constants as follows:

$$\begin{bmatrix} V + \\ V - \\ V_x \end{bmatrix} = \begin{bmatrix} n + & s + & e + \\ n - & s - & e - \\ n_s & s_s & e_s \end{bmatrix} \begin{bmatrix} N \\ S \\ Ne \end{bmatrix} \quad 4.8$$

or $V = A.F.$

or $F = A^{-1}V$

where

- $V +$ = output voltage from + normal circuit
- $V -$ = output voltage from - normal circuit
- V_s = output voltage from the shear circuit
- N = normal load
- S = shear load
- Ne = moment, normal load x eccentricity
- A = matrix of load cell constants

If the first row of eqn 4.8 is considered:

$$V + = N (n +) + S (s +) + Ne (e +) \quad 4.9$$

and the derivative with respect to S is

$$\frac{d V +}{d s} = 0 + (s +) + 0$$

Physically this could be accomplished by setting N=e=0 and varying S. The slope of a plot of V + vs S would be the load cell constant S + .

Similarly considering the second and third rows of eqn 4.8 the cell constants s- and ss can be determined, as in figure 13 page 62 .

Now again considering eqn 4.9, if S=0 and e is constant, the derivative with respect to N is:

$$\frac{d V +}{d N} = n + 0 + e (e +) \quad 4.10$$

Calibration tests were performed with S=0 and various values of e, allowing a plot to be made of $\frac{d V+}{d N}$ vs e

This plot would have an $e=0$ intercept equal to $n +$ and a slope of $e +$, as shown in figure 17, page 66.

Similarly considering again the second and third rows of eqn 4.8 it is possible to determine load cell constants $n -$, $e -$, n_s and e_s .

In order to determine the load cell constants a series of calibration tests were performed as follows:

Calibration Tests:

- (a) Fix $N = e = 0$, and vary S from 0 to 400 lbs in 50 lb increments and then from 400 pounds to 0, the results are plotted on figure 13, page 62 for cell number 1.
- (b) Fix $S = 0$; and $e = 0$, varying N from 0 to 400 pounds in 50 pound increments and return to zero. Plot the results as in figures 14, 15, 16, pages 63, 64, 65, for cell number 1.
- (c) Fix $S = 0$ and $e = 0.75$ inch from the centre, of the cell face plat, vary N from 0 to 400 pounds in 50 pound increments, plotting the results as in figures 14, 15, 16 pages 63, 64, 65 for cell number 1.

(d) Fix $s = 0$ and $e = 0.5$ inch and vary N from 0 to 400 pounds in 50 pounds increments plotting the results as in figures 14, 15, 16, pages 63, 64, 65, for cell number 1.

(e) Fix $s = 0$ and $e = 0.25$ inch and vary N from 0 to 400 pounds in 50 pounds increments plotting the results as in figures 14, 15, 16 page 63, 64, 65, for cell number 1.

(f) Fix $s = 0$ and $e = 0.5$ inch and vary N from 0 to 400 pounds in 50 pound increments plotting the results as in figures, 14, 15, 16, pages 63, 64, 65, for cell number 1.

The calibration curves of load cells 2, 3, 4, 5 and 6 are contained on figures 18 to 42 pages 67 to 91.

Load cell constants for each cell were determined as outlined above, and are substituted into equation 4.8.

$$\begin{array}{l} \text{N Cell Cell No. 1} \\ \begin{array}{l} V_+ \\ V_- \\ V_3 \end{array} \end{array} = 10^{-4} \begin{bmatrix} 190 & -45 & 196 \\ 190 & 100 & -239 \\ 13 & 525 & -12 \end{bmatrix} \begin{array}{l} N \\ S \\ Ne \end{array}$$

$$\begin{array}{l} \text{Cell No. 2} \\ \begin{array}{l} V_+ \\ V_- \\ V_s \end{array} \end{array} = 10^{-4} \begin{bmatrix} 184 & -85 & 232 \\ 198 & 95 & -246 \\ 13 & 553 & -8 \end{bmatrix} \begin{array}{l} N \\ S \\ Ne \end{array}$$

$$\text{Cell No. 3} \quad \begin{bmatrix} V+ \\ V- \\ V_s \end{bmatrix} = 10^{-4} \begin{bmatrix} 191 & -65 & 230 \\ 204 & 65 & -242 \\ 8 & 450 & 0 \end{bmatrix} \begin{bmatrix} N \\ S \\ Ne \end{bmatrix}$$

$$\text{Cell No. 4} \quad \begin{bmatrix} V+ \\ V- \\ V_s \end{bmatrix} = 10^{-4} \begin{bmatrix} 192 & -78 & 242 \\ 186 & 73 & -234 \\ 7 & 510 & 0 \end{bmatrix} \begin{bmatrix} N \\ S \\ Ne \end{bmatrix}$$

$$\text{Cell No. 5} \quad \begin{bmatrix} V+ \\ V- \\ V_s \end{bmatrix} = 10^{-4} \begin{bmatrix} 188 & -59 & 224 \\ 198 & 85 & -246 \\ 12 & 413 & 0 \end{bmatrix} \begin{bmatrix} N \\ S \\ Ne \end{bmatrix}$$

$$\text{Cell No. 6} \quad \begin{bmatrix} V+ \\ V- \\ V_s \end{bmatrix} = 10^{-4} \begin{bmatrix} 183 & -40 & 232 \\ 189 & 58 & 234 \\ 8 & 425 & 0 \end{bmatrix} \begin{bmatrix} N \\ S \\ Ne \end{bmatrix}$$

V INSTALLATION OF THE LOAD CELLS

5.1 Footing Description

The cells were installed in a footing constructed from three steel plates which were mounted on an 8 inch x 8 inch I - beam. The cells were fixed to a 5/8 inch plate and lay located between two 1 1/2 inch plates as shown in figure 43,

page 92. The plates were bolted together and then bolted to the I - beam. The assembled footing is two feet long and one foot wide and weighs 228 pounds.

5.2 Cell Mounting

The cells were bolted to the 5/8 inch steel plate by four counter sunk bolts. A portion of this plate was drilled out to allow the wires from the cells to pass out of the top of the footing. The cells were mounted with a clearance of 0.003 inches between cells and 0.002 inches between the cells and the neighboring steel plates. The even numbered cells were placed on one side of the footing causing the final order of the cells to be 6,4,2,1,3,5 as shown in figure 44 , page 93. The cells were installed and the mounting bolts were tightened with a uniform torque of 5 foot pounds. During calibration it was found that the torque on the mounting bolts affect the zero reading on the cells but not the actual calibration. The cells were mounted such that the direction of positive shear forces for cells 2,4,6 and 1,3,5 were to the nearest edge of the footing. The direction of positive shear force was determined during calibration by the calibration set up as the direction from the + normal webs to the - normal

webs to the + normal webs. The cells were each engraved with a plus and minus sign for this purpose. The direction of positive eccentricity is from the - normal web to the + normal web.

5.3 Cell Face Plate Coating

The face plate of the cell is made from aluminum and is 1.5 inches by 2.0 inches. The surface of the face plate was prepared to have a roughness similar to the sand to be used in footing tests. This was accomplished by the use of an EPY 150 epoxy coating on the face plate to which a liberal amount of sand was pressed into place. The epoxyed face plates were baked in a 150° oven for 2 hours and then removed and allowed to cool. The excess sand was brushed off the face plates. The footing surface was prepared in the same manner. Direct shear tests were performed on a portion of aluminium with the epoxy-sand preparation. These tests were performed to determine the angle of friction between the prepared plate and a sand mass. Tests were run for different values of relative density of the sand mass. The results of the tests are contained on figure 45, page 94, which indicates a maximum friction angle of 37.3 degrees. A grain size distribution is enclosed as figure 46 along with the relationship be-

tween normal stress and angle of shearing resistance, figure 47, according to Hasanin (7), as compared to tests conducted on the epoxied sand surface.

VI TESTING OF FOOTING

6.1 Testing Apparatus

The instrumented footing was load tested in a sand box on a prepared bed of sand. The sand bed was approximately five feet deep and was placed using the sand spreading apparatus that was available. Attempts were made to place the sand in as uniform a condition as possible to aid in interruption of test results. The sand was placed quickly and in a loose condition. The sand bed was not uniform after placement and was levelled prior to placement of the footing. It is believed that support conditions of the sand were not uniform for the test. The instrumented footing was positioned on the sand surface using an overhead crane. Loads were applied to the footing using a 10 ton capacity jack which acted through a ball joint mounted on the top of the footing. A calibration curve for the jack is shown on Figure 48 page 97.

An 8 by 8 WF section was mounted across the top of the

sand box for use as a reaction. Settlement of the footing was recorded using a two dial gauges mounted on a channel section and recording the settlements at each end of the footing.

6.2 Test Procedure

Loads were applied to the footing in increments of 1000 pounds from zero to 21,000 pounds. Measurements were taken of output voltage from all 3 bridge circuits and of settlement from the two dial gauges. The readings are contained on Table 6.1, and on figures 49 to 54 pages 98 to 103.

6.3 Reduction of Observations

In section 4.11, the load cell constants were determined and substituted into equation 4.8, which can be written in the form:

$$V = A, F \quad 6.1$$

where V are the output voltages of the bridge circuits

A is the matrix of load cell constants

F are the forces of acting on the load cell

In order to determine these forces we must write eqn

6.1 in the form :

$$F = A^{-1} \times V$$

where A^{-1} is the inverse of A

TABLE 6-1

cell no.	1			2			3			4			5			6		
channel	1	2	3	4	5	6	7	8	9	10	11	12	13	14	15	16	17	18
load lbs	output voltage (millivolts)																	
zero load	0.0	0.0	0.0	-1.5	0.0	0.0	0.0	0.0	0.0	0.0	0.0	3.0	0.0	0.0	0.0	0.0	0.0	0.0
footing weight	0.0	0.0	0.0	-1.1	0.0	0.0	0.1	0.3	0.2	0.1	0.1	3.0	-0.1	0.1	0.2	0.1	0.1	0.1
1000	0.1	0.1	0.1	-1.1	0.1	-0.1	0.2	0.4	0.3	0.2	0.3	3.1	0.1	0.2	0.2	0.3	0.2	0.1
2000	0.2	0.3	0.2	-1.0	0.2	-0.1	0.4	0.6	0.3	0.4	0.5	3.1	0.2	0.3	0.3	0.5	0.4	0.2
3000	0.3	0.4	0.2	-0.9	0.3	-0.1	0.6	0.8	0.3	0.6	0.7	3.2	0.4	0.4	0.3	0.8	0.6	0.3
4000	0.4	0.5	0.3	-0.8	0.4	-0.1	0.9	0.9	0.4	0.7	0.9	3.2	0.5	0.5	0.4	1.0	0.8	0.4
5000	0.6	0.6	0.4	-0.7	0.5	-0.2	0.9	1.2	0.4	0.9	1.2	3.2	0.6	0.6	0.4	1.2	1.0	0.5
6000	0.7	0.7	0.4	-0.6	0.6	-0.2	1.1	1.4	0.5	1.1	1.4	3.2	0.8	0.7	0.5	1.4	1.2	0.6
7000	0.8	0.8	0.5	-0.5	0.7	-0.2	1.3	1.5	0.5	1.2	1.6	3.2	0.9	0.8	0.6	1.7	1.4	0.6
8000	0.9	1.0	0.5	-0.4	0.8	-0.2	1.5	1.7	0.6	1.4	1.8	3.2	1.1	1.0	0.6	1.9	1.5	0.7
9000	1.0	1.1	0.6	-0.3	0.9	-0.3	1.6	1.8	0.6	1.6	2.0	3.2	1.2	1.1	0.7	2.1	1.7	0.8
10,000	1.2	1.2	0.7	-0.2	1.0	-0.3	1.8	2.0	0.6	1.7	2.2	3.2	1.4	1.2	0.8	2.3	1.9	0.9
11,000	1.3	1.3	0.7	-0.1	1.1	-0.3	1.9	2.2	0.7	1.8	2.4	3.2	1.5	1.3	0.8	2.5	2.1	0.9
12,000	1.4	1.4	0.8	0.0	1.2	-0.3	2.0	2.3	0.7	2.0	2.5	3.2	1.6	1.4	0.9	2.7	2.2	1.0
13,000	1.5	1.6	0.9	0.1	1.4	-0.4	2.3	2.6	0.8	2.2	2.8	3.2	1.9	1.6	1.0	3.0	2.4	1.2
14,000	1.6	1.7	0.9	0.2	1.4	-0.4	2.5	2.8	0.8	2.4	3.0	3.2	2.0	1.7	1.1	3.2	2.6	1.2
15,000	1.7	1.8	0.9	0.3	1.5	-0.4	2.5	2.8	0.8	2.4	3.0	3.2	2.1	1.8	1.1	3.3	2.6	1.2
16,000	1.8	1.9	1.0	0.4	1.6	-0.4	2.7	3.0	0.9	2.6	3.3	3.2	2.3	1.9	1.2	3.6	2.8	1.4
17,000	2.0	2.0	1.1	0.5	1.7	-0.4	2.9	3.2	0.9	2.8	3.5	3.2	2.5	2.0	1.2	3.8	2.9	1.4
18,000	2.1	2.1	1.1	0.6	1.8	-0.5	3.0	3.4	1.0	2.9	3.8	3.2	2.6	2.1	1.3	4.0	3.0	1.6
19,000	2.2	2.2	1.2	0.7	1.9	-0.5	3.2	3.5	1.0	3.1	4.0	3.1	2.8	2.2	1.3	4.2	3.2	1.6
20,000	2.3	2.3	1.2	0.7	2.0	-0.5	3.3	3.7	1.1	3.2	4.1	3.1	2.9	2.3	1.4	4.4	3.3	1.7
21,000	2.4	2.4	1.3	0.8	2.1	-0.5	3.5	3.9	1.1	3.4	4.4	3.1	3.1	2.4	1.4	4.6	3.5	1.8

The inverses of the matrices of load cell constants determined in section 4.11 are as follows:

Cell No. 1	A_1^{-1}	=	28.9	23.8	- 2.1
			- 0.2	- 1.1	19.2
			22.9	-23.4	6.4
Cell No. 2	A_2^{-1}	=	27.0	25.4	- 0.2
			- 0.3	- 0.9	18.2
			21.6	-20.5	6.8
Cell No. 3	A_3^{-1}	=	26.0	24.7	0.2
			- 0.5	- 0.4	22.2
			21.8	-20.6	6.1
Cell No. 4	A_4^{-1}	=	26.0	26.9	0.1
			- 0.4	- 0.4	19.6
			20.6	-21.5	6.2
Cell No. 5	A_5^{-1}	=	27.2	24.8	- 1.2
			- 0.8	- 0.7	24.2
			21.6	-20.9	7.4

		27.0	26.8	- 1.1
Cell No. 6	A_6^{-1}	= - 0.5	- 0.5	23.6
		21.7	-21.2	4.9

The three load components may now be calculated from the output voltages from the following equation :

$$\begin{aligned} N &= A^{-1} V^{+'} \\ S &= A^{-1} V^{-'} \\ Ne &= V_s \end{aligned}$$

- where
- N = normal load in pounds
 - S = shear load in pounds
 - Ne = normal load times the eccentricity of the normal load
 - V+ = output voltage of the '+' normal circuit
 - V- = output voltage of the '-' normal circuit
 - S = output voltage of the shear circuit

For example if we consider the output voltages from the three bridge circuits, for cell No. 1, at a load of 21,000 pounds, from Table I, $V^{+'} = 2.4$ mv, $V^{-'} = 2.4$ mv, $V_s = 1.3$ mv, we can determine the three load components as follows:

$$F = V A,^{-1}$$

$$\text{or } \begin{bmatrix} N \\ S \\ Ne \end{bmatrix} = \begin{bmatrix} 28.9 & 23.8 & -2.1 \\ -0.2 & -1.1 & 19.2 \\ 22.9 & -23.4 & 6.4 \end{bmatrix} \begin{bmatrix} 2.4 \\ 2.4 \\ 1.3 \end{bmatrix}$$

$$= \begin{matrix} 28.9 \times 2.4 & + & 23.8 \times 2.4 & - & 2.1 \times 1.3 \\ -0.2 \times 2.4 & - & 1.1 \times 2.4 & + & 19.2 \times 1.3 \\ 22.9 \times 2.4 & - & 23.4 \times 2.4 & + & 6.4 \times 1.3 \end{matrix}$$

$$\begin{matrix} N & 69.4 & + & 57.1 & - & 2.7 \\ S & = & -0.5 & - & 2.6 & + & 25.0 \\ Ne & 55.0 & - & 56.2 & + & 8.3 \end{matrix}$$

N = 123.8 = normal load in pounds

S = 21.9 = shear load in pounds

Ne = 7.1 = moment caused by the eccentricity
of the normal load

$$\text{and } e = \frac{7.1}{123.8} = + .058 \text{ inches}$$

From this we can see that cell number 1 has a normal force of 123.8 pounds acting at an eccentricity of .058 inches from the centre, and a shear force of 21.9 pounds. In a

similar manner the load components of the other cells can be determined from their output voltages.

6.4 Results of Load Test

A plot of load versus settlement for the footing test is enclosed as figure 55, page 104. This curve indicates a uniform settlement occurs at each end of the footing, and that the ultimate bearing capacity of the foundation material has been realized as excessively large settlements are produced by small load increments. Figure 56, page 105, shows the distribution of shear and normal forces for various increments of load. All tests were carried out at room temperature.

6.5 Conclusions

Results of the footing test indicate that the objectives as outlined in subsection 1.2 have been met. Earth pressure cells have been manufactured, have been installed in a footing and measurements of the shear and normal force distribution across the footing have been made.

VII DISCUSSIONS AND CONCLUSIONS

7.1 Discussion

Ideally, to determine the distribution of the normal and shear stresses over the surface of a spread footing, large numbers of very small pressure cells would be used. However, this is impracticable since the forces required on the small cell area would be too small to measure with any degree of accuracy. The larger the cell, the easier it is to measure the forces involved and the greater is the accuracy of this measurement. Also, the larger the cell the less it is influenced by arching of the soil over the cell force. The upper limit to the size of the cell is, of course, the surface area of the device into which it is mounted, in this case the spread footing.

For the one foot wide strip footing that was the subject of the present work, a compromise was arrived at. Six 2 inch by 1.5 inch cells were installed side by side across the width of the footing. This size of cell allowed the forces to be measured with reasonable accuracy while limiting the deflection of the rigid surface of the cell to a tolerable amount.

A wider footing, say 18 inches wide, would allow 9 cells to be placed across the width. It is thought that this number would give a more meaningful picture of the stress distributions.

Figure 56 indicates that the total average normal stress measured was 4.0 tons per square foot, while the applied stress was 5.0 tons per square foot. The major reason for this discrepancy is believed to be the non uniform nature of the sand bed on which the test was performed.

The direct shear tests performed on the epoxy-sand surface indicate that the angle of shearing resistance is lower than those values obtained during triaxial tests performed by Hasnain (7), particularly at lower normal stresses. The maximum angle of shear resistance for the epoxy-sand surface was found to be 37.3 degrees. The angle may indicate the point where the epoxy-sand surface breaks down.

7.2 Conclusions

A survey of existing methods measuring normal and shear stresses at the boundary of a soil mass led to the

adoption of Cambridge cells for the spread footing. This is a rigid face plate cell with electrical resistance strain gauges to measure the forces which act on the cell.

With the 6 cells across the width of the footing, an impression can be gained of the normal and shear stress determination, Figure 56, page 105, shows both the normal and shear forces measured at each cell at several different load levels; the normal forces are located at their points of action. One thing is immediately apparent, the force levels are higher towards the edge of the footing than towards the middle. Secondly, the measured, shear forces do not add up to zero.

According to Figure 56, there is a net force of some 50 pounds at the highest load level in one direction so the footing should be sliding across the surface of the sand - which it was not doing. This may mean that the footing was kept from sliding by the passive resistance of the sand along the side of the footing, by net shear forces in the opposite direction at their locations along the footing by a certain amount of fixity in the loading system or by an inclined load on the footing giving the necessary horizontal component of force. To produce the net shear force the footing would have to be at an angle of about 2.2 degrees which would not be easily apparent.

The rigid face plate integrates the shear and normal stresses which act over the surface of the plate. In the case of normal stresses, the portion of the resultant of these stresses may be determined.

A sufficient quantity of earth pressure cells were produced and installed in a footing to make it possible to measure the distribution of shear and normal forces over the face of the footing.

It is anticipated that the Cambridge cells will provide the information that is sought on the project outlined in section 2.1 concerning the distribution of stresses under a spread footing.

7.3 Suggestions For Further Work

The Cambridge cells themselves appeared to work very well. They were easy to calibrate and give constant calibration factors on repeat tests. One difficulty was with the recording devices which were used. They were found to be cumbersome and time consuming. For future use, it is recommended that an electronic readout system be used with electronic rather than mechanical switching from one bridge circuit to the next. These two electronic features will

reduce the time lag between circuit readings and make the readings more nearly simultaneous. Reducing the time lag can be important at footing loads which approach the ultimate when continual creep can alter the force levels quite quickly.

Further work should include stricter control of the sand bed. This will eliminate many of the problems which are associated with interpretation of test results.

A few words of caution. Direct shear tests on the epoxy-sand surface of the cell faces indicated that the surface should be inspected periodically to assess wear. It may prove necessary to renew the surface from time to time, or develop a surface with more durability. The calibration of these individual cells should be checked from time to time since the long term stability of the cells was not checked during the course of the present work.

LIST OF REFERENCES

1. Agarwal S.L. and Venkatesen "An Instrument to Measure Skin Friction and Normal Earth Pressures on Deep Foundations" Instruments and Apparatus for Soil and Rock Mechanics, ASTM STP 392, Am. Soc. Test. Mats., pp 152-169, 1965.
2. Arthur J.R.F. and Roscoe K.H. "An Earth Pressure Cell for the Measurement of Normal and Shear Stresses" Civil Engineering and Public Works Review, Vol. 56 No. 659, pp 765-770, 1961.
3. Bozozuk M. "The Gloucester Test Fill "PhD Theses, Purdue University, Dept. of Civil Engineering, Lafayette, Indiana 1972, pp 49-60.
4. Goldbeck A.T. and Smith E.B. "An Apparatus for Determining Soil Pressures" Proceeding, Am. Soc. for Test. Mat. Vol. 16, No. 2, pp 310-319, 1916.
5. Hanna T.H. "Foundation Instrumentation" Trans Teck Publications, 1973.

6. Hartikainen J. "On The Distribution and Direction of Contact Pressure Under a Rigid Foundation Civil Engineering and Building Construction, Series No. 74, Helsinki, 1972.
7. Hasnain M. "Shear Strength Characteristics of a Crushed Quartz Sand". M.A.Sc. Thesis, University of Ottawa, 1974.
8. Muhs H. Discussion, Sixth International Conference on Soil Mechanics and Foundation Engineering, Canada, 1965, Vol. 3, pp 436-439.
9. Peattie K.R. and Sparrow R.W. "A Review of the Design of Earth Pressure Cells" Civil Engineering and Public Works Review, Vol. 50, No. 590, pp 872-874, 1955.
10. Prange B. "Stress Strain Behaviour of Soils" Proceedings of the Roscoe Memorial Symposium, Cambridge University, March 1971, pp 484-488.
11. U.S. Waterways Experimental Station "Soil Pressure Cell Investigation" Technical Memorandum, No. 21D-1, 1944.

FIGURES

2



2

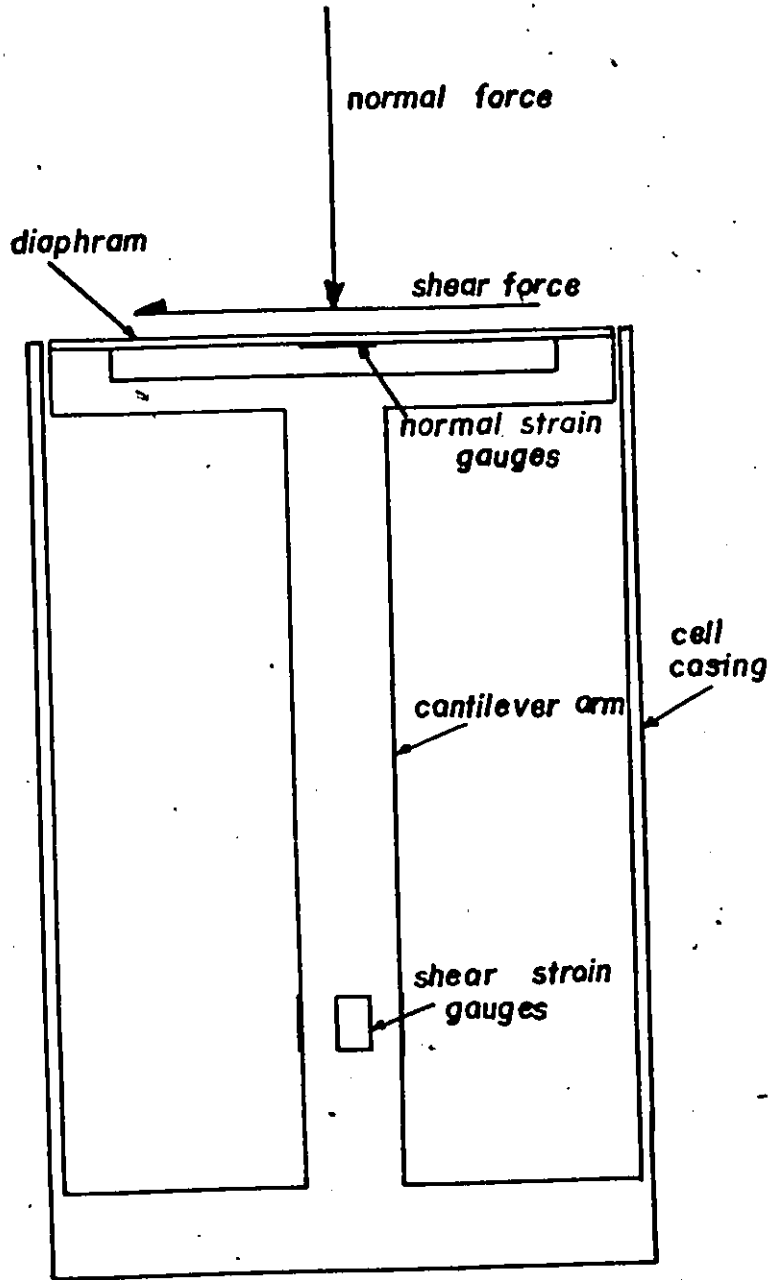

SCHMATIC AGARWAL and VENKATESAN CELL

figure 1

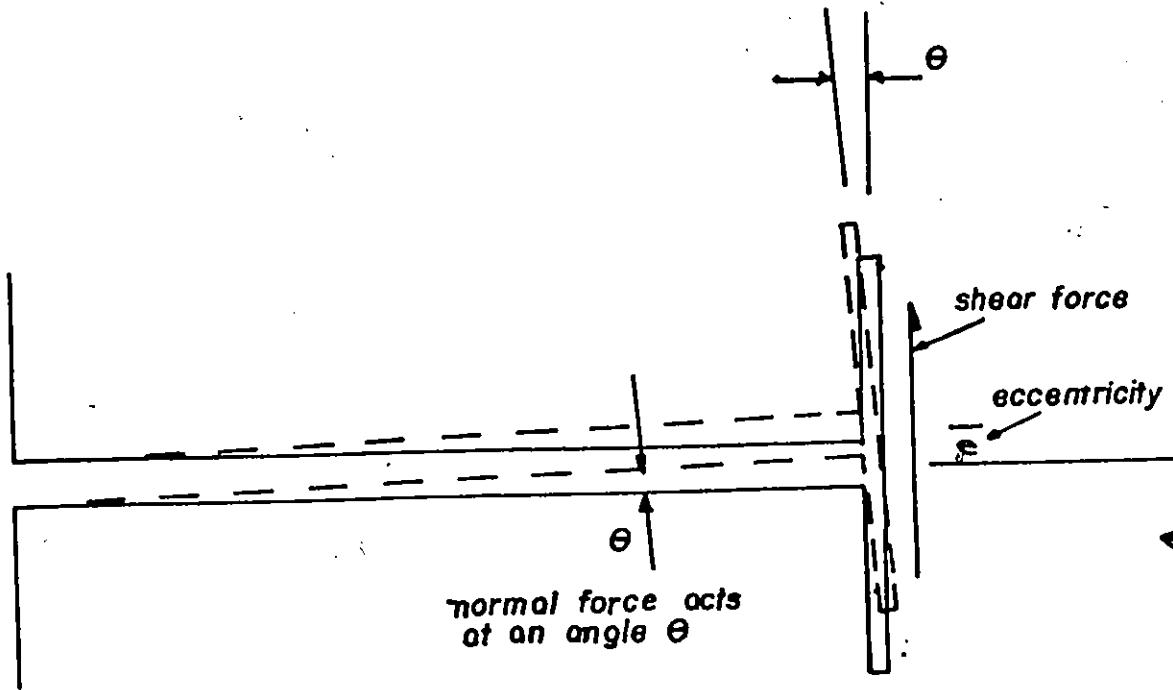

TRANSLATION of ACTIVE FACE

figure 2

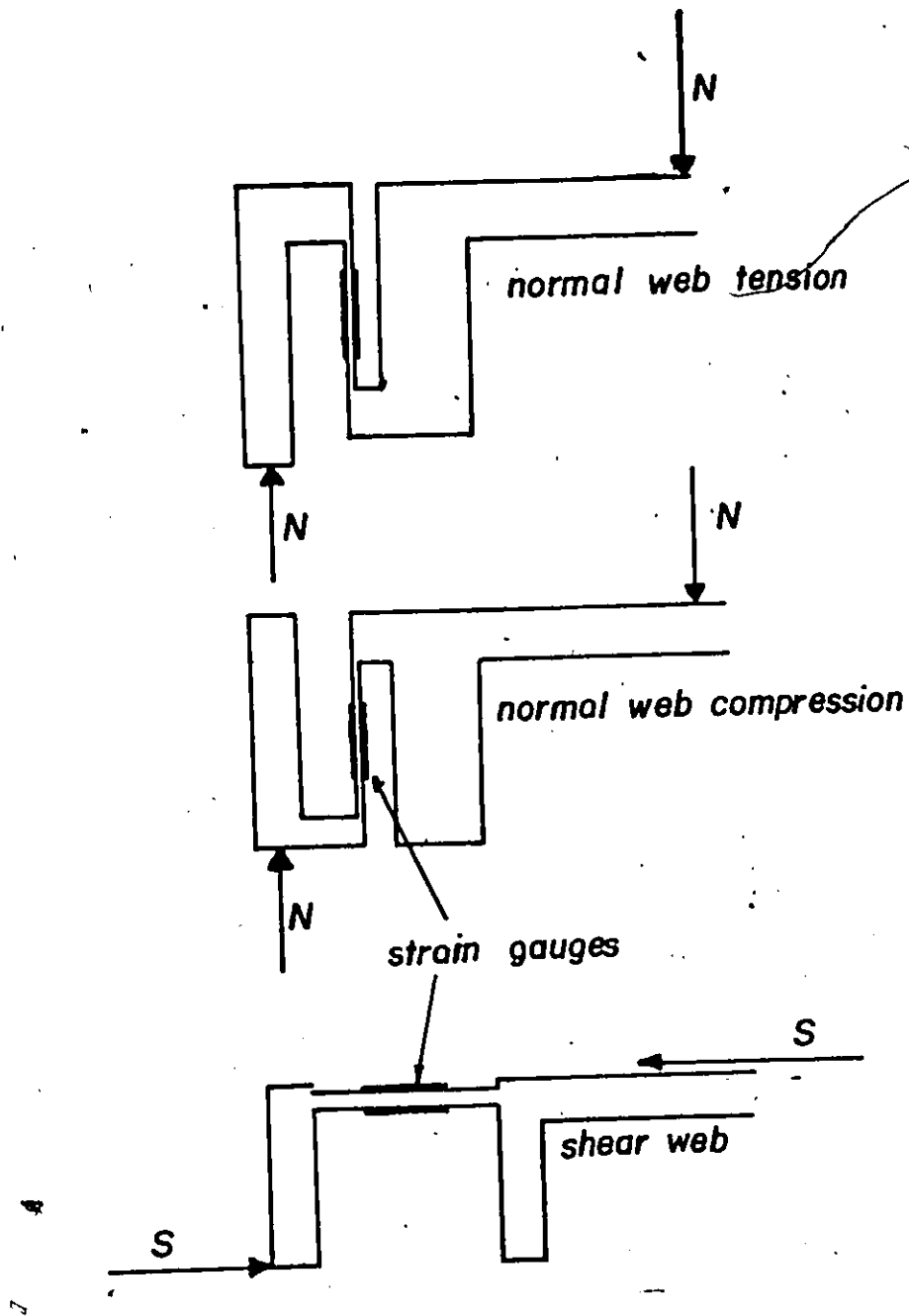

TELEMETRIC PRESSURE CELL
MEASURING WEBS

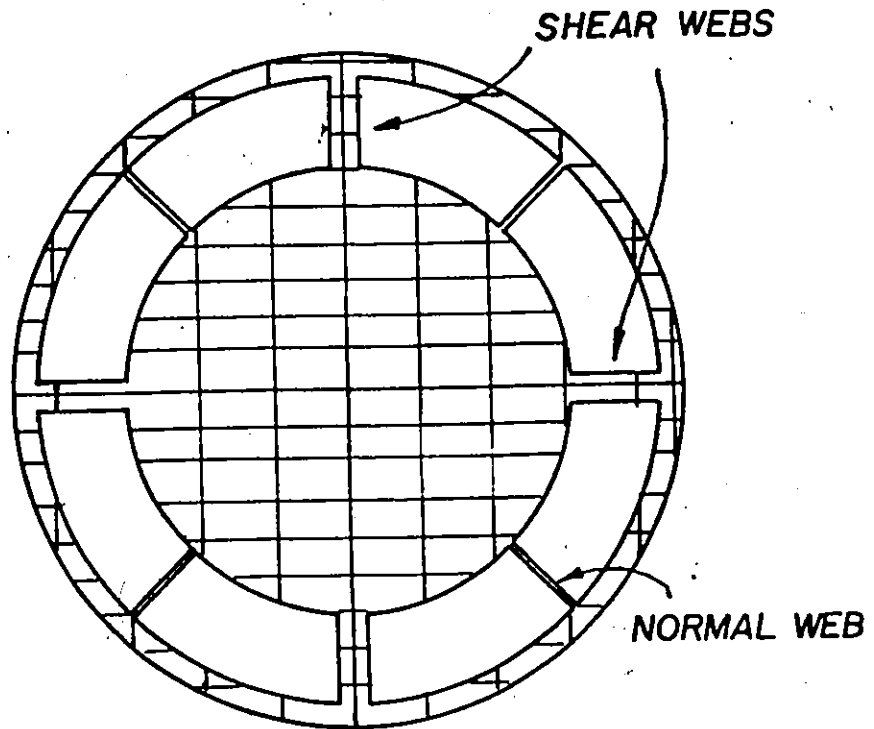

TELEMETRIC CELL SCHEMATIC

figure 4

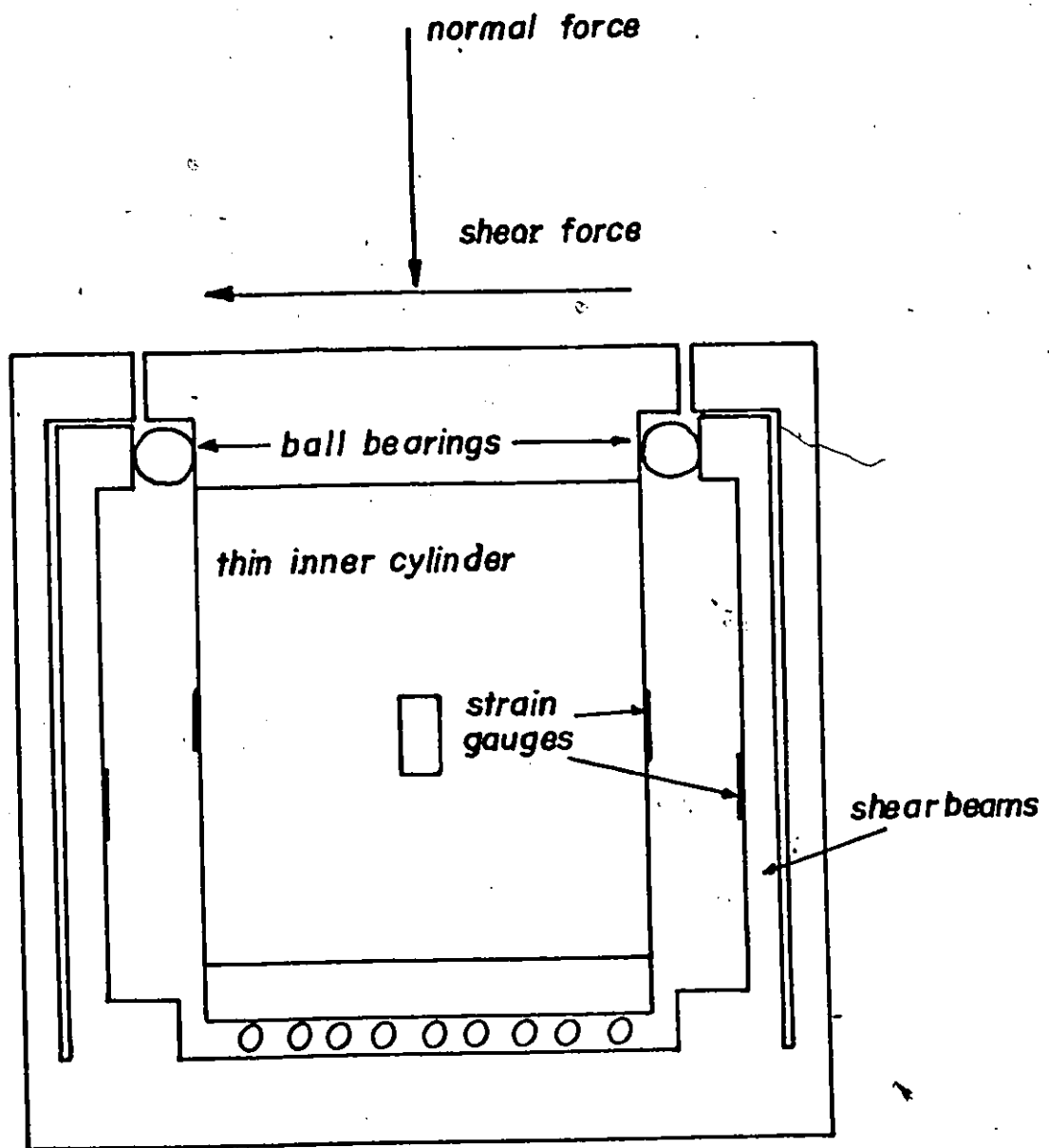

SCHEMATIC of MUHS CELL

figure 5

dummy normal gauges (total 8)

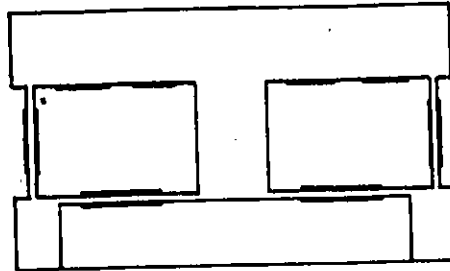

active normal gauges
(total 8)

shear gauges
(total 4)

STRAIN GAUGES ON ORIGINAL
CAMBRIDGE CELL

figure 6

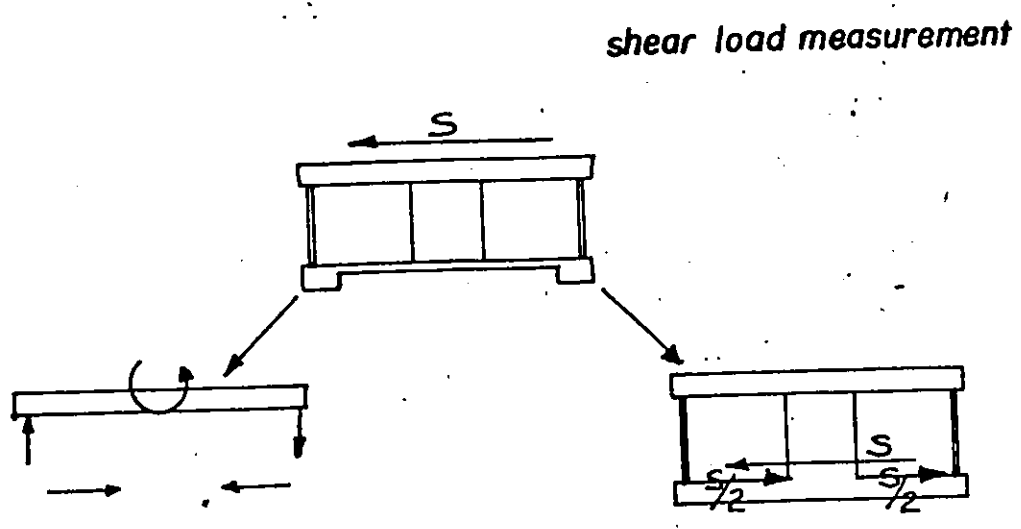
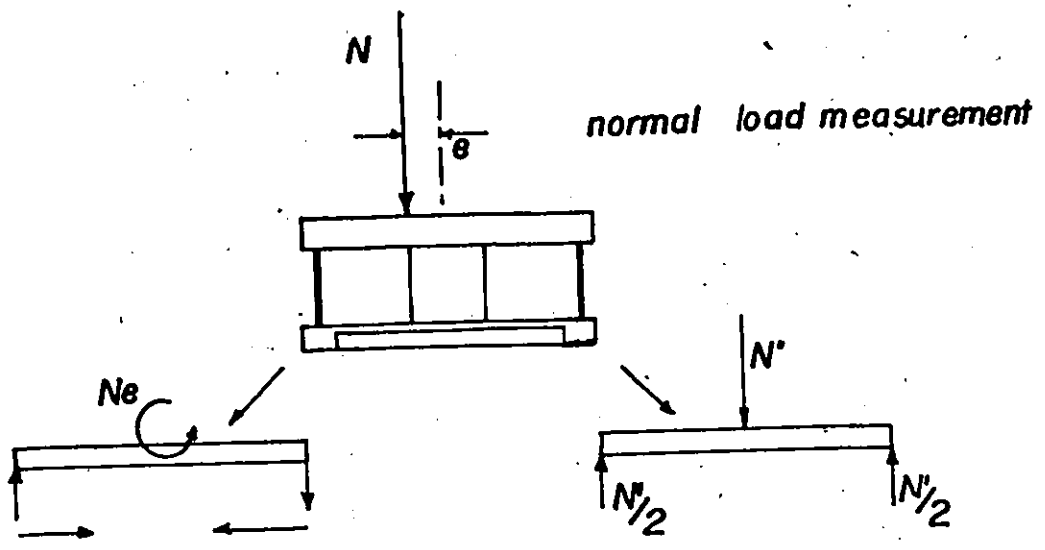

STRAIN IN WEBS

figure 7

MODIFIED CAMBRIDGE CELL

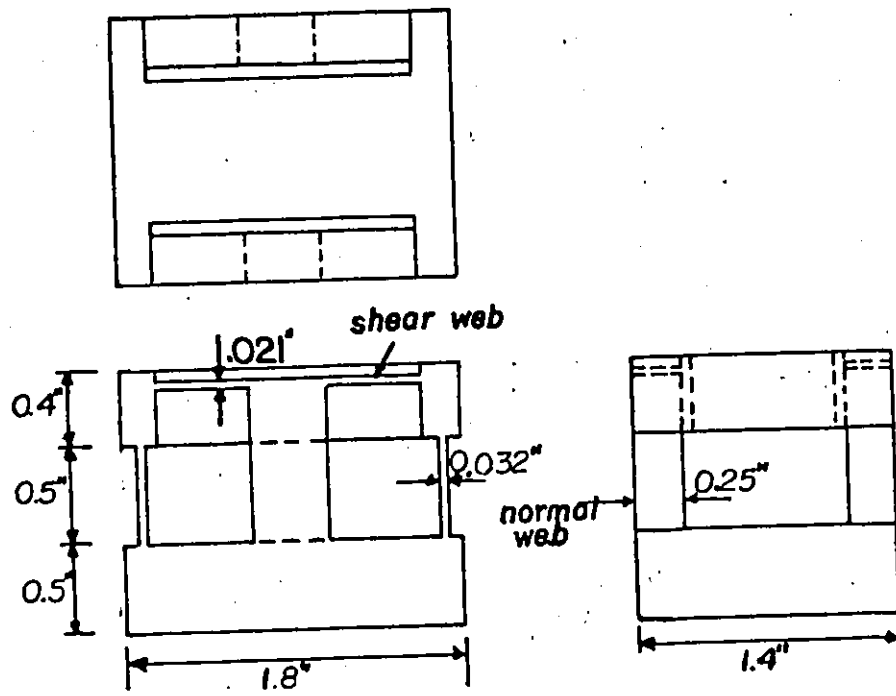

ORIGINAL CAMBRIDGE CELL

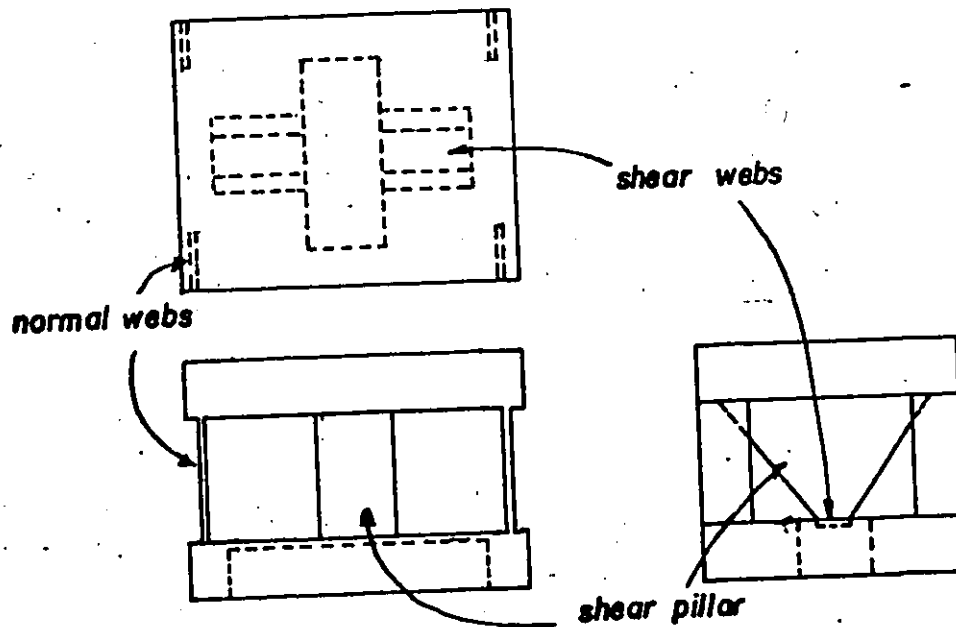
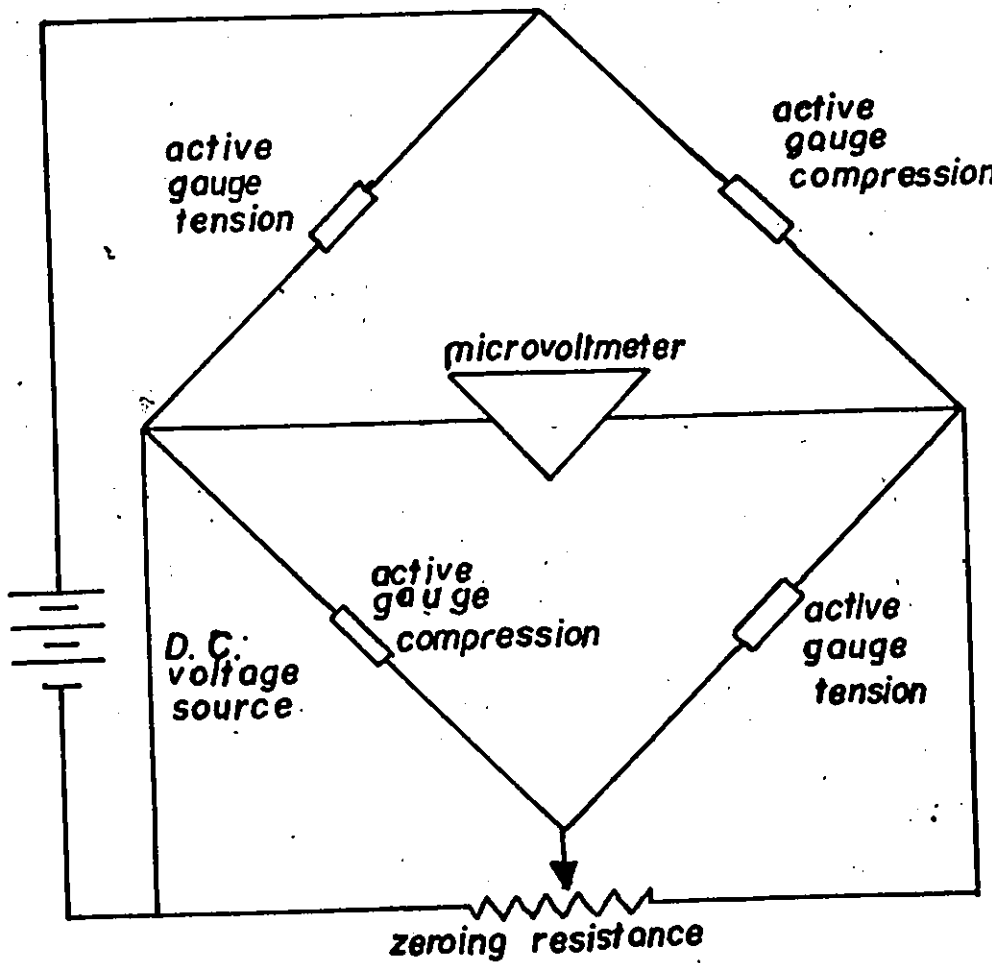
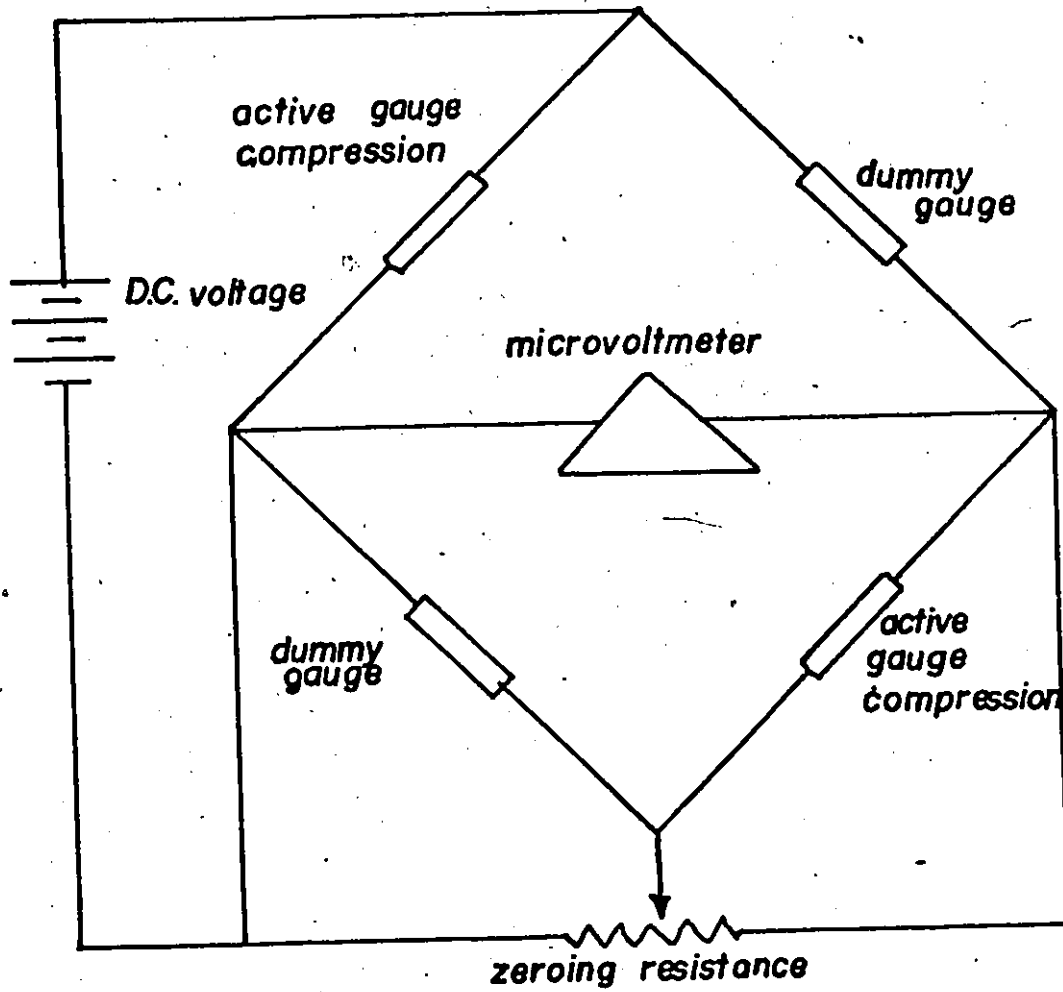

figure 8



**SHEAR BRIDGE CIRCUIT
WIRING DIAGRAM**



**NORMAL BRIDGE CIRCUIT
WIRING DIAGRAM**

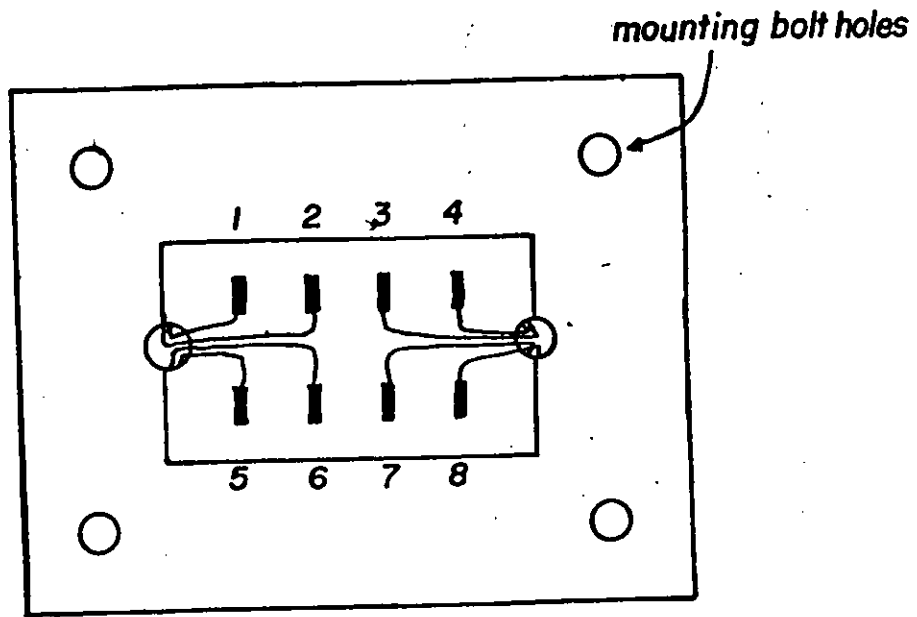

- 1,2 - 6 volts D.C.
- 3,4 - output - normal bridge circuit
- 5,6 - " + " " "
- 7,8 - " shear " "

resistance circuit checks

- 1-2 , 40 ohms
- 3-4 , 120 ohms
- 5-6 , 120 ohms
- 7-8 , 120 ohms

CELL TERMINAL

figure 11

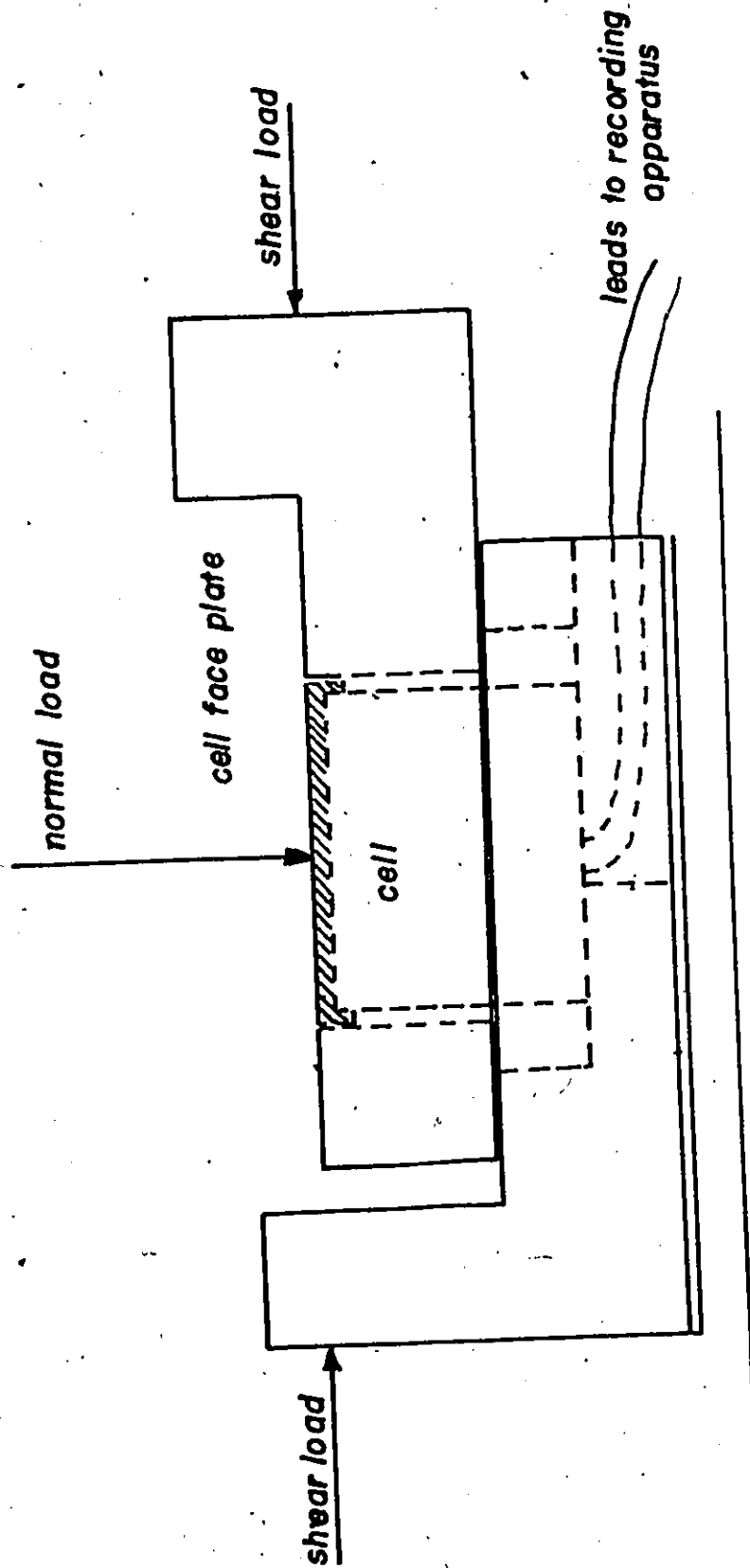

CALIBRATION MOUNT

figure 12

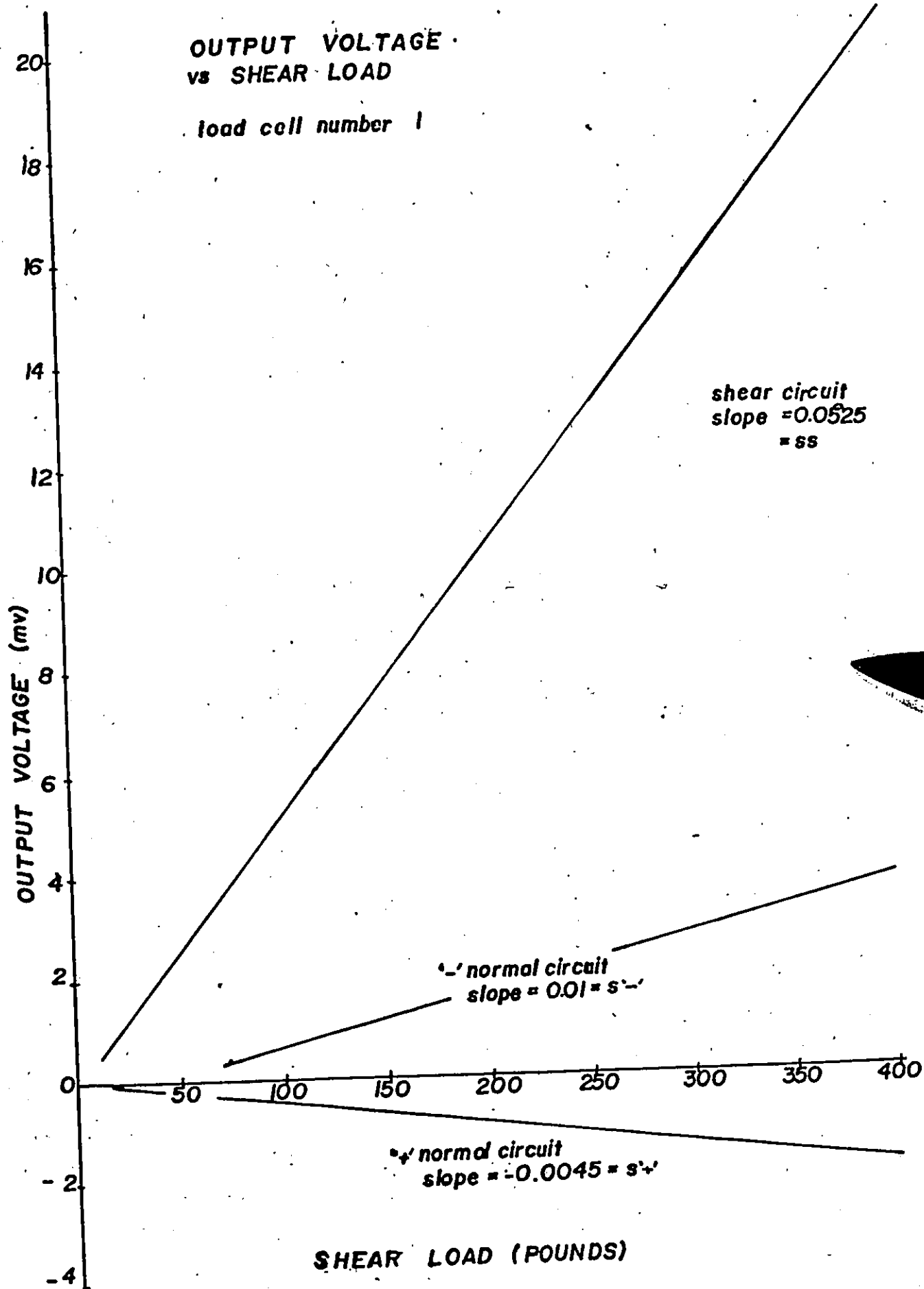

figure 13

**OUTPUT VOLTAGE
vs NORMAL LOAD**

load cell number 1

eccentricity e (inches)

figure 14

OUTPUT VOLTAGE
vs NORMAL LOAD

load cell number 1

eccentricity e (inches)

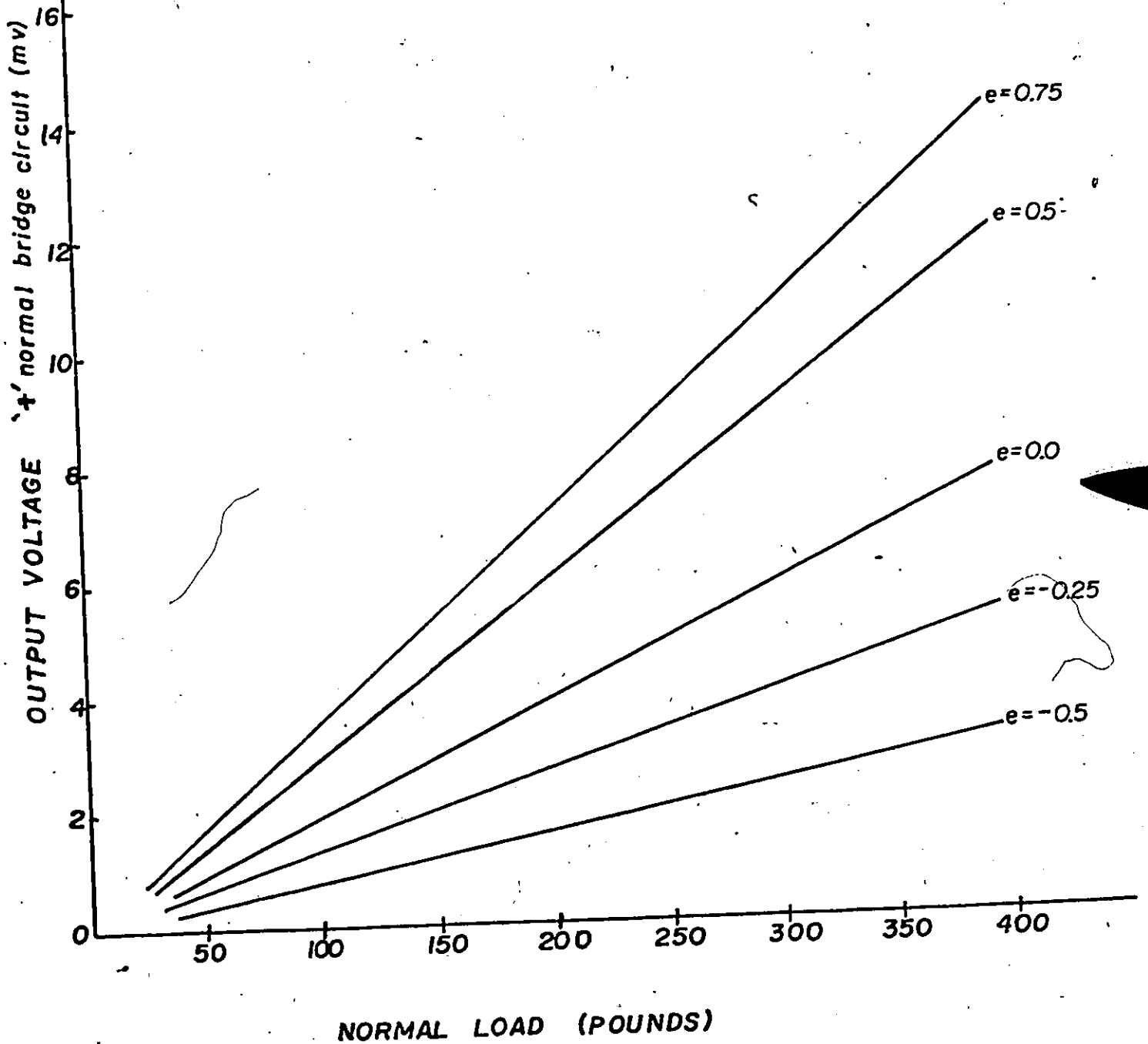
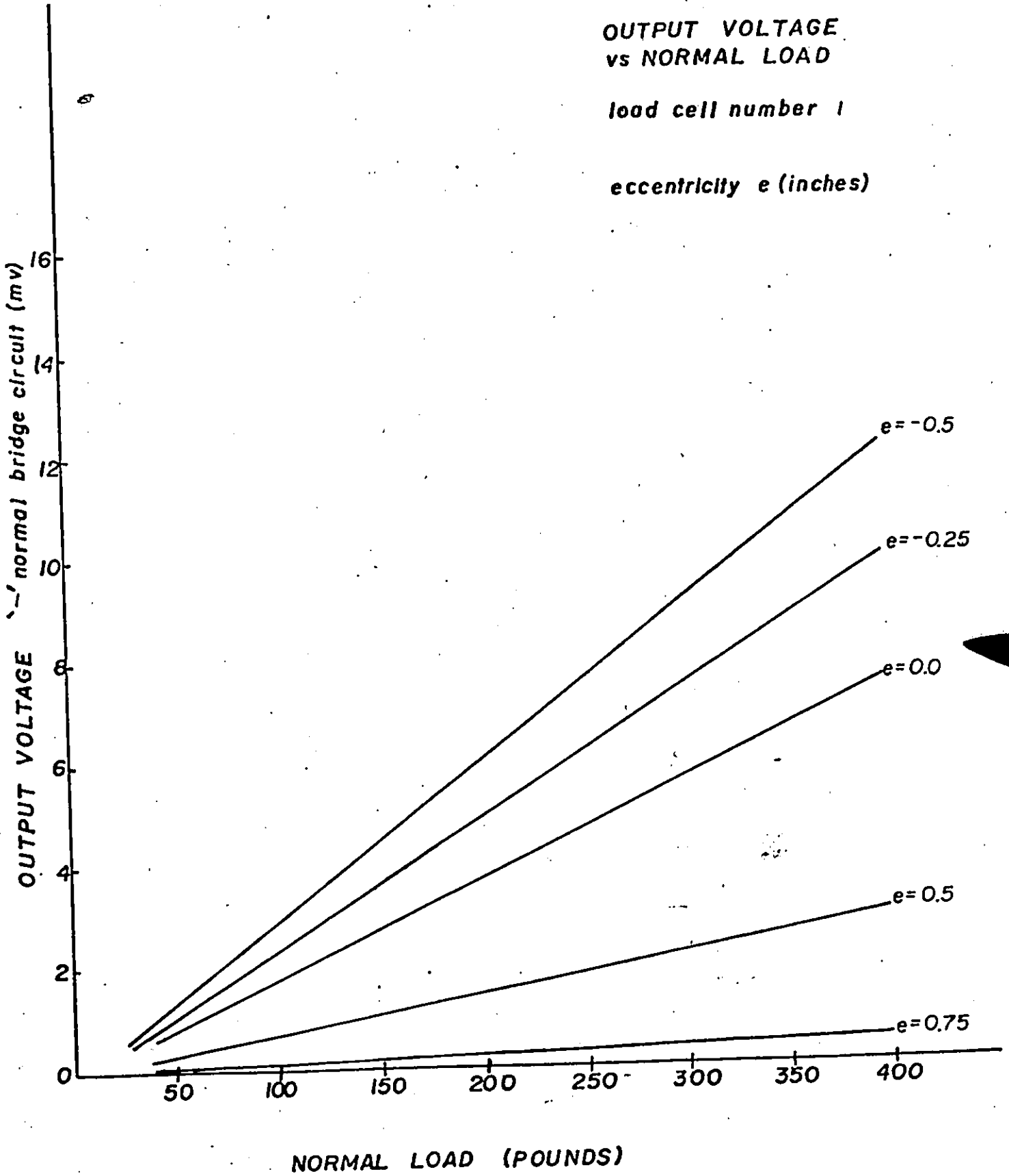

figure 15

**OUTPUT VOLTAGE
vs NORMAL LOAD**

load cell number 1

eccentricity e (inches)

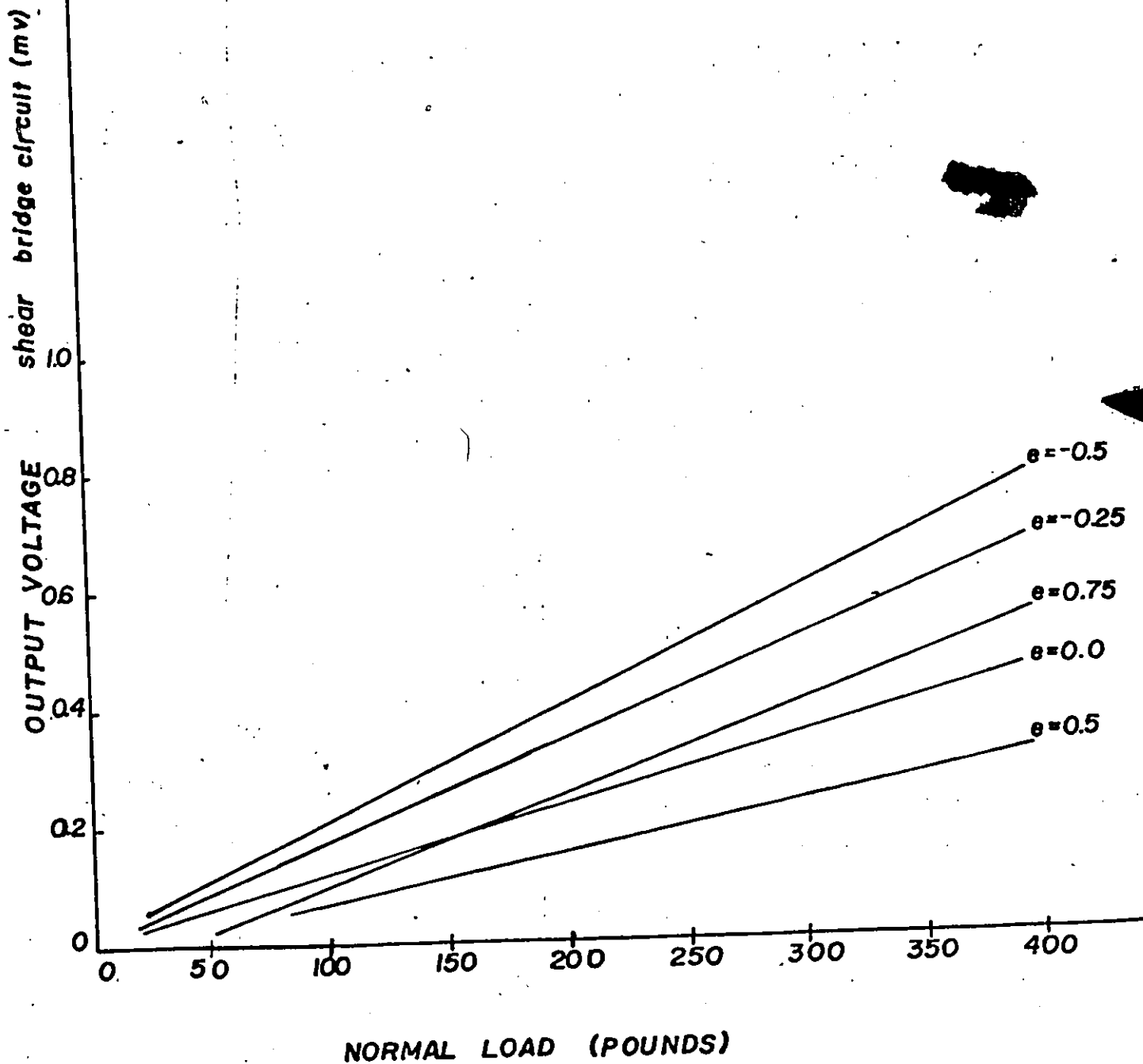

figure 16

DERIVATIVE of OUTPUT VOLTAGE
w.r.t. NORMAL LOAD
vs ECCENTRICITY

load cell number 1

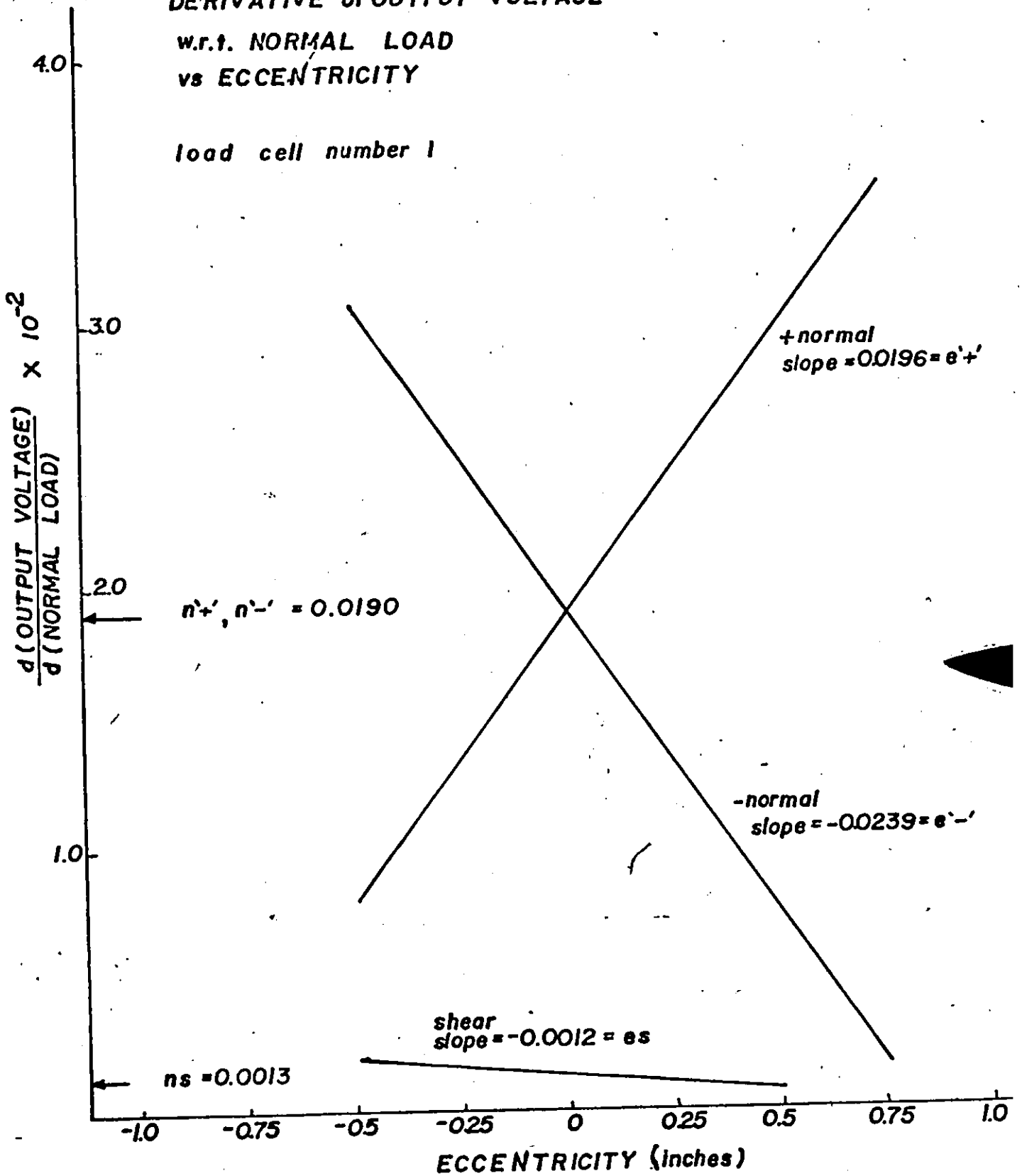

figure 17

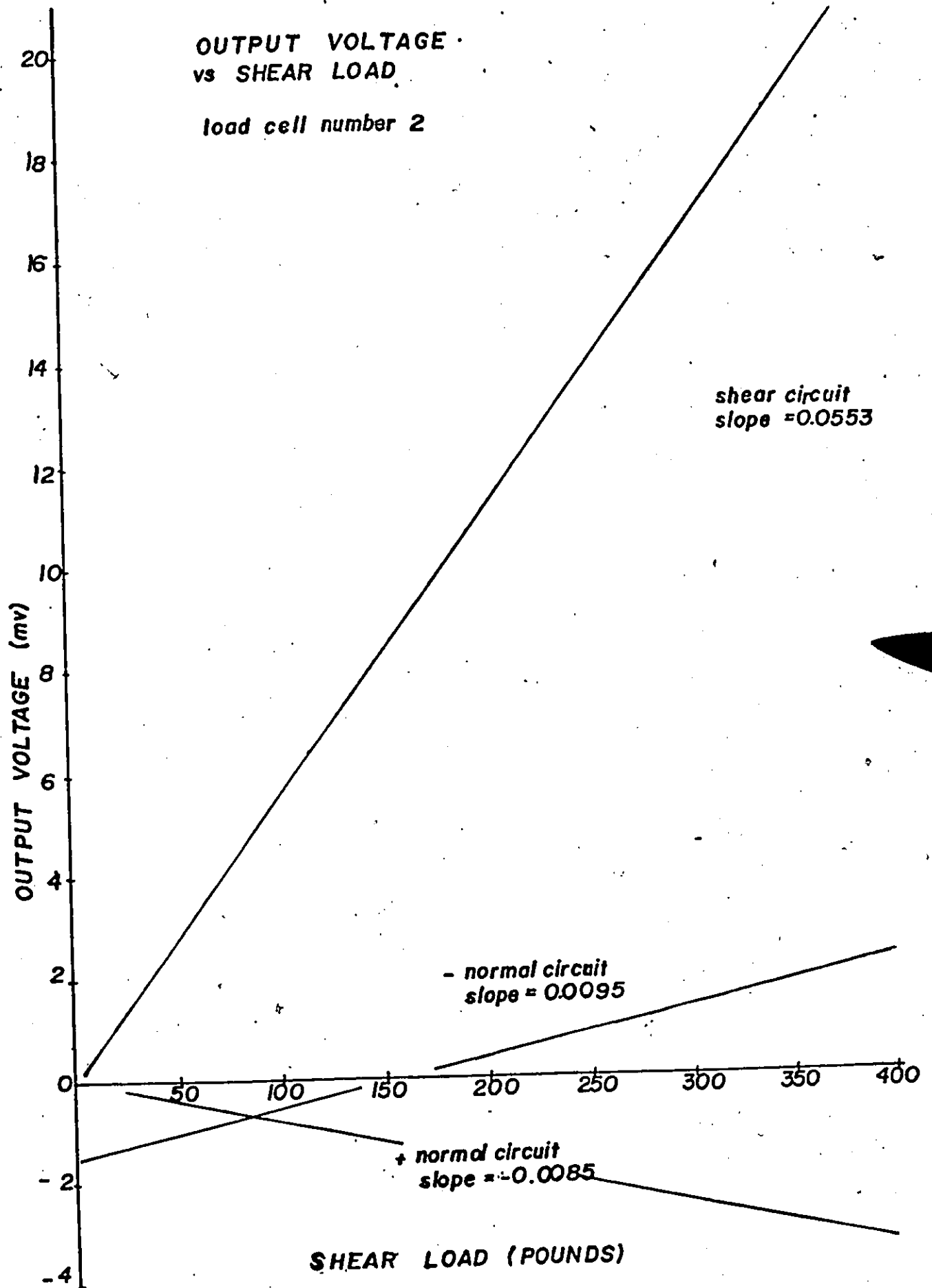

figure 18

OUTPUT VOLTAGE
vs NORMAL LOAD

load cell number 2

eccentricity e (inches)

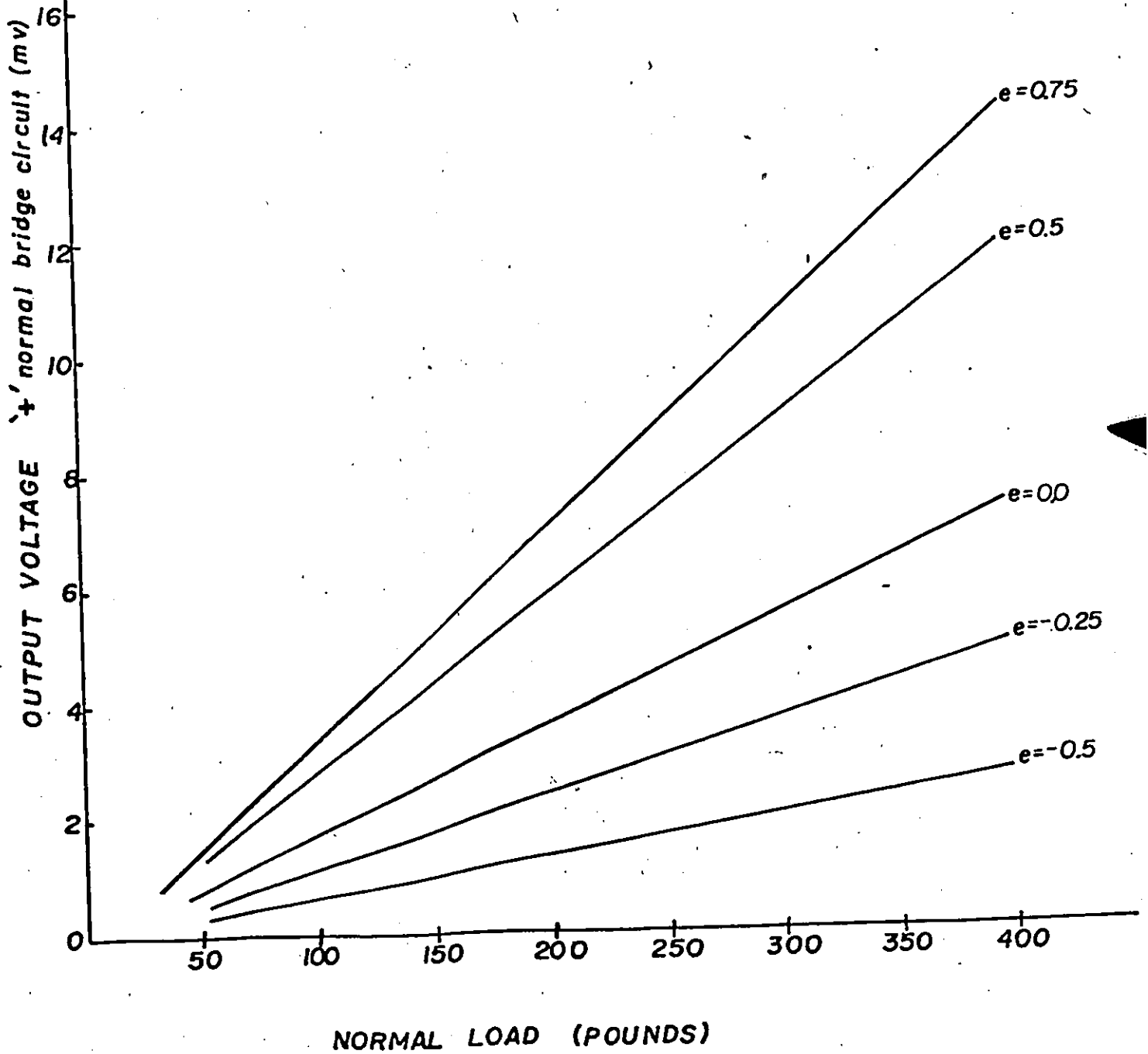

figure 19

OUTPUT VOLTAGE
vs NORMAL LOAD

load cell number 2

eccentricity e (inches)

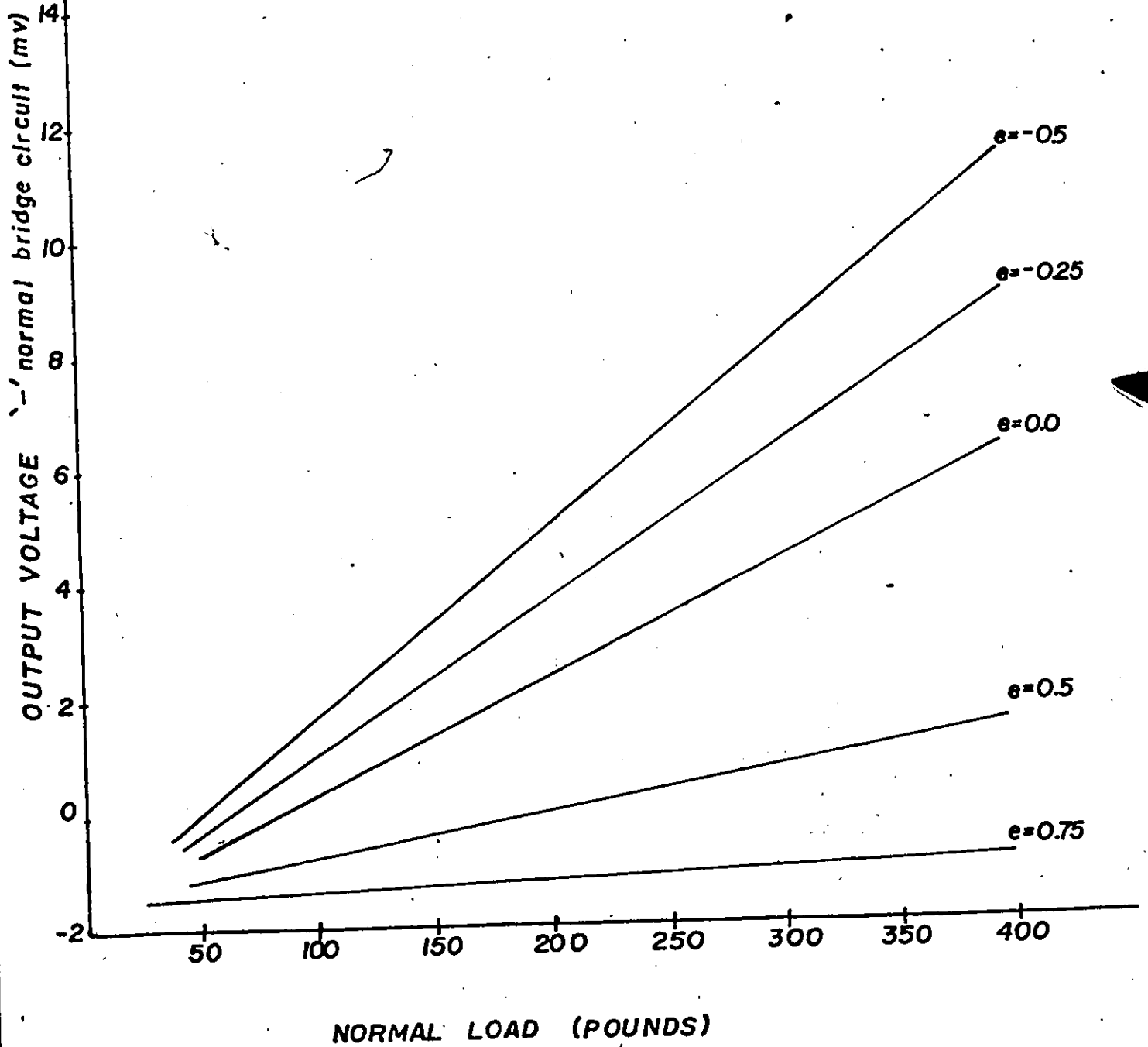

figure 20

**OUTPUT VOLTAGE
vs NORMAL LOAD**

load cell number 2

eccentricity e (inches)

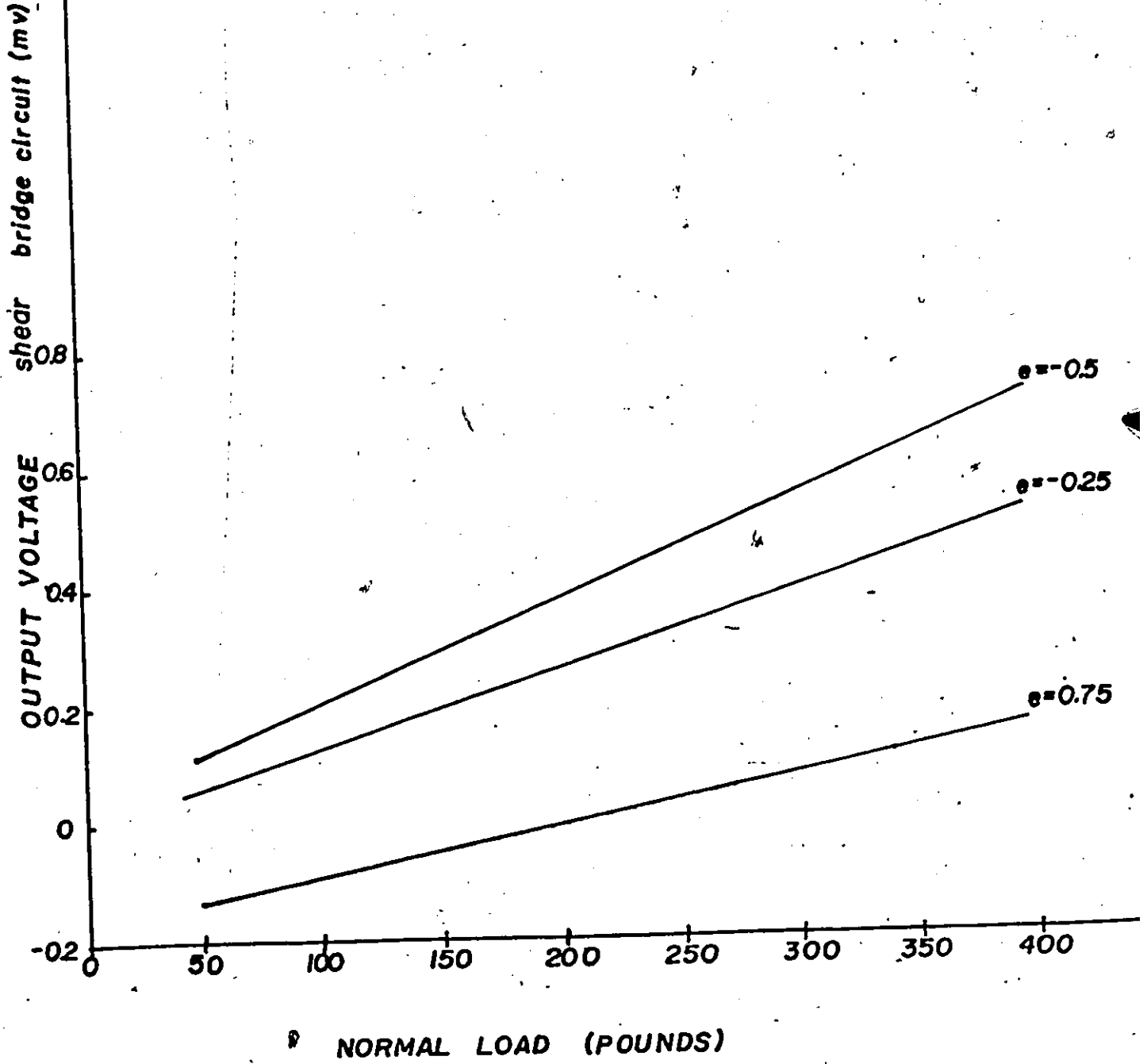

figure 21

DERIVATIVE of OUTPUT VOLTAGE
w.r.t. NORMAL LOAD
vs ECCENTRICITY

load cell number 2

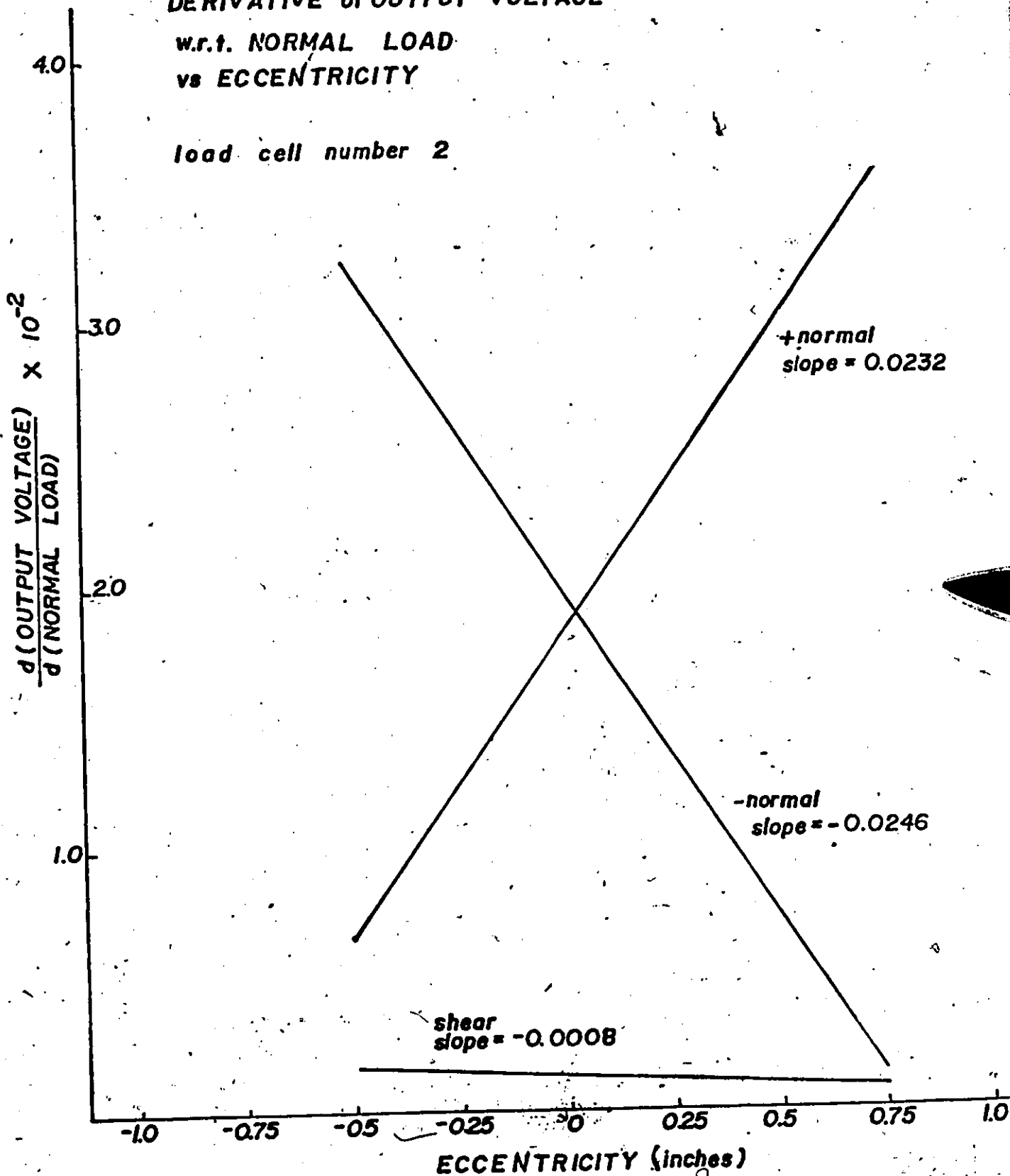

figure 22

OUTPUT VOLTAGE vs SHEAR LOAD

load cell number 3

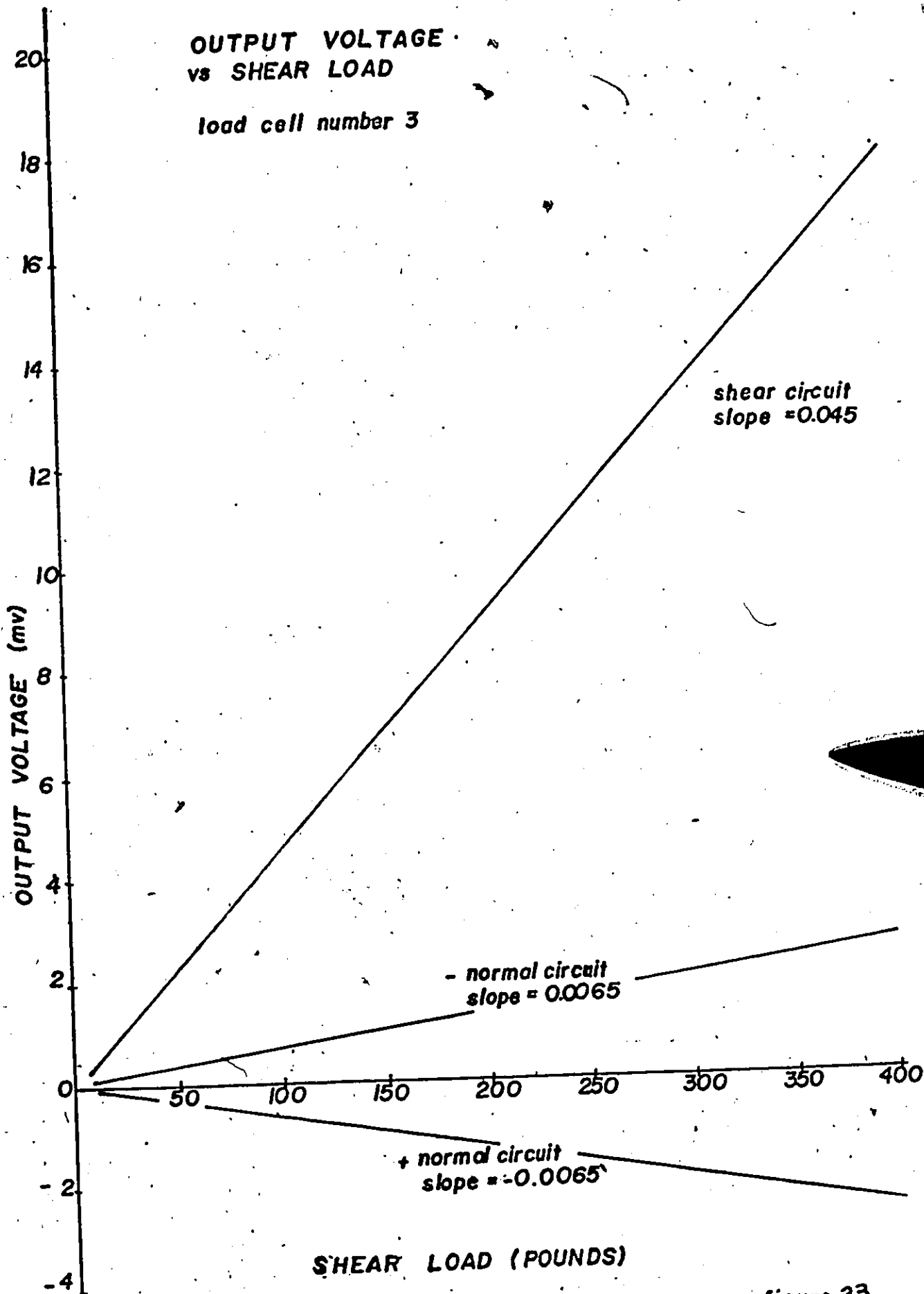

figure 23

**OUTPUT VOLTAGE
vs NORMAL LOAD**

load cell number 3

eccentricity e (inches)

figure 24

OUTPUT VOLTAGE
vs NORMAL LOAD

load cell number 3

eccentricity e (inches)

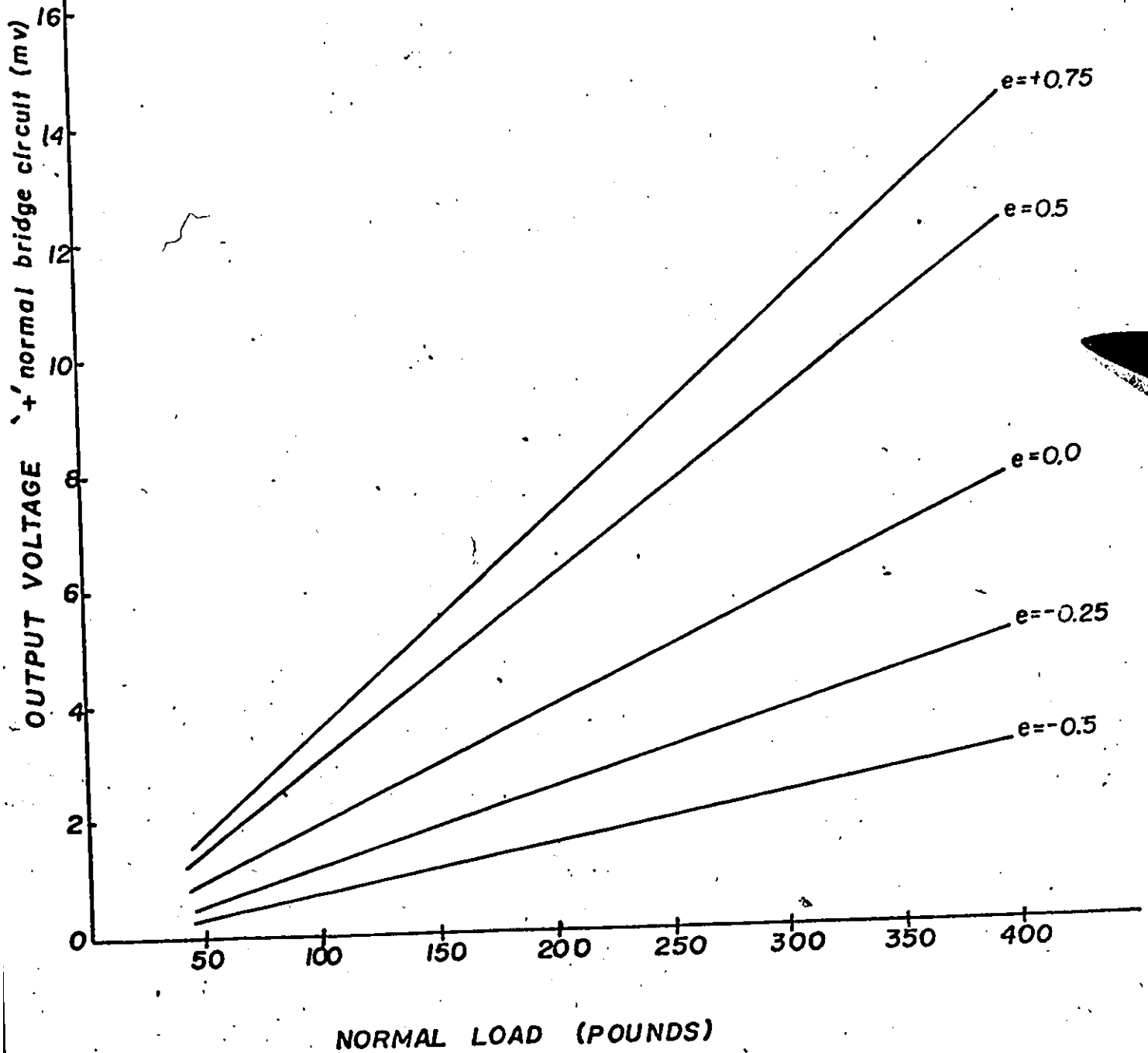
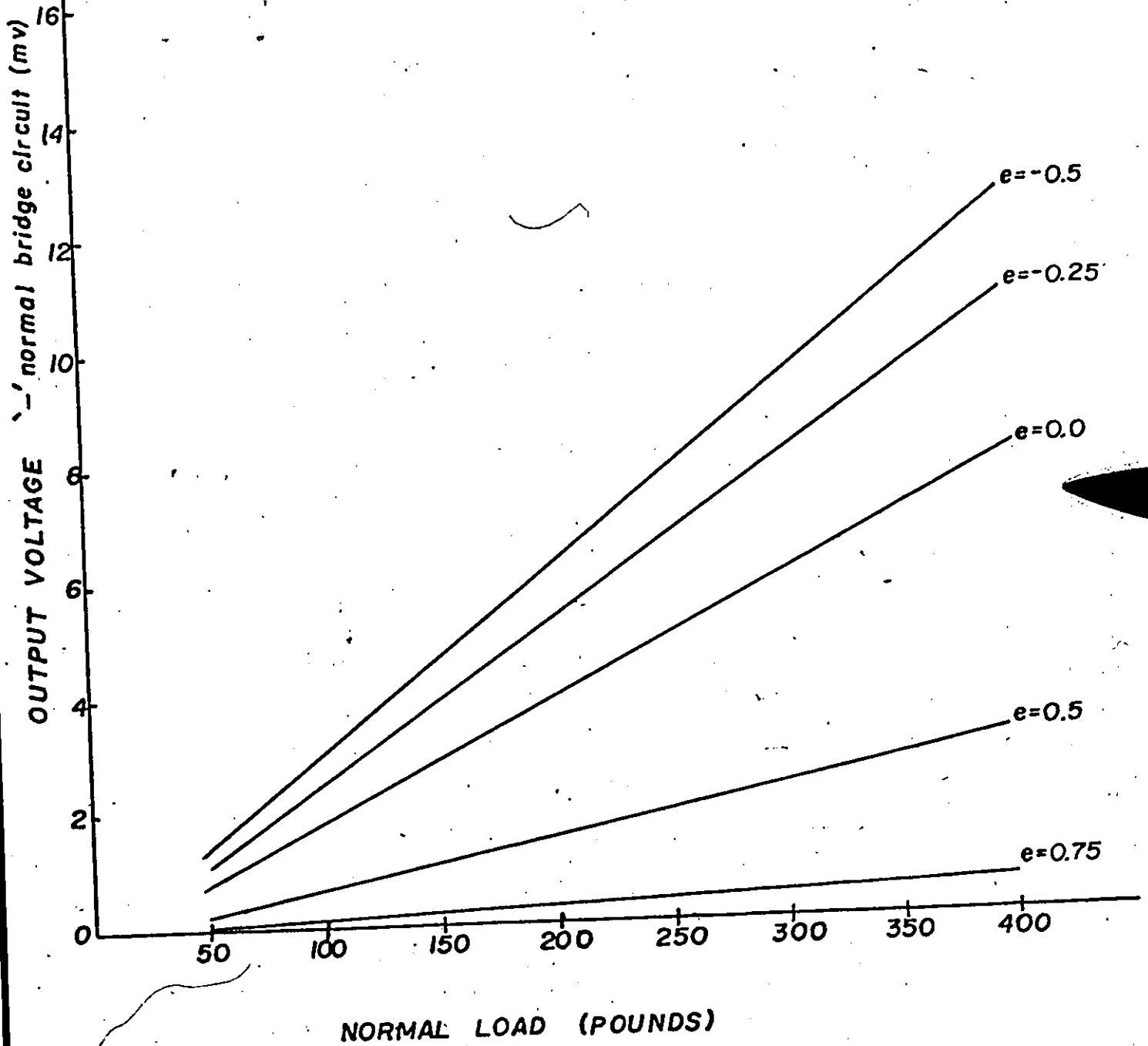

figure 25

OUTPUT VOLTAGE
vs NORMAL LOAD

load cell number 3

eccentricity e (inches)

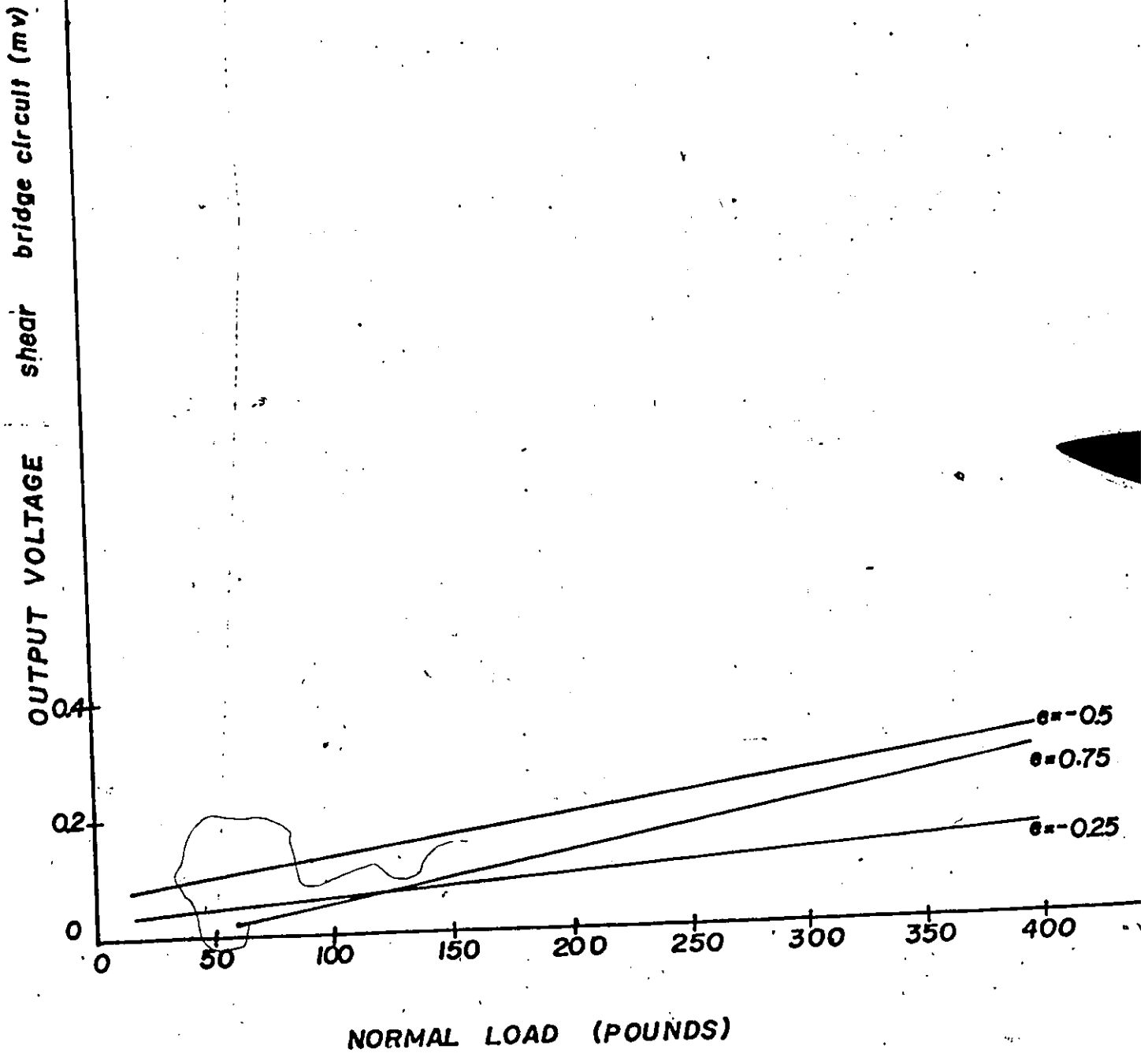

figure 26

DERIVATIVE of OUTPUT VOLTAGE
w.r.t. NORMAL LOAD
vs ECCENTRICITY

load cell number 3

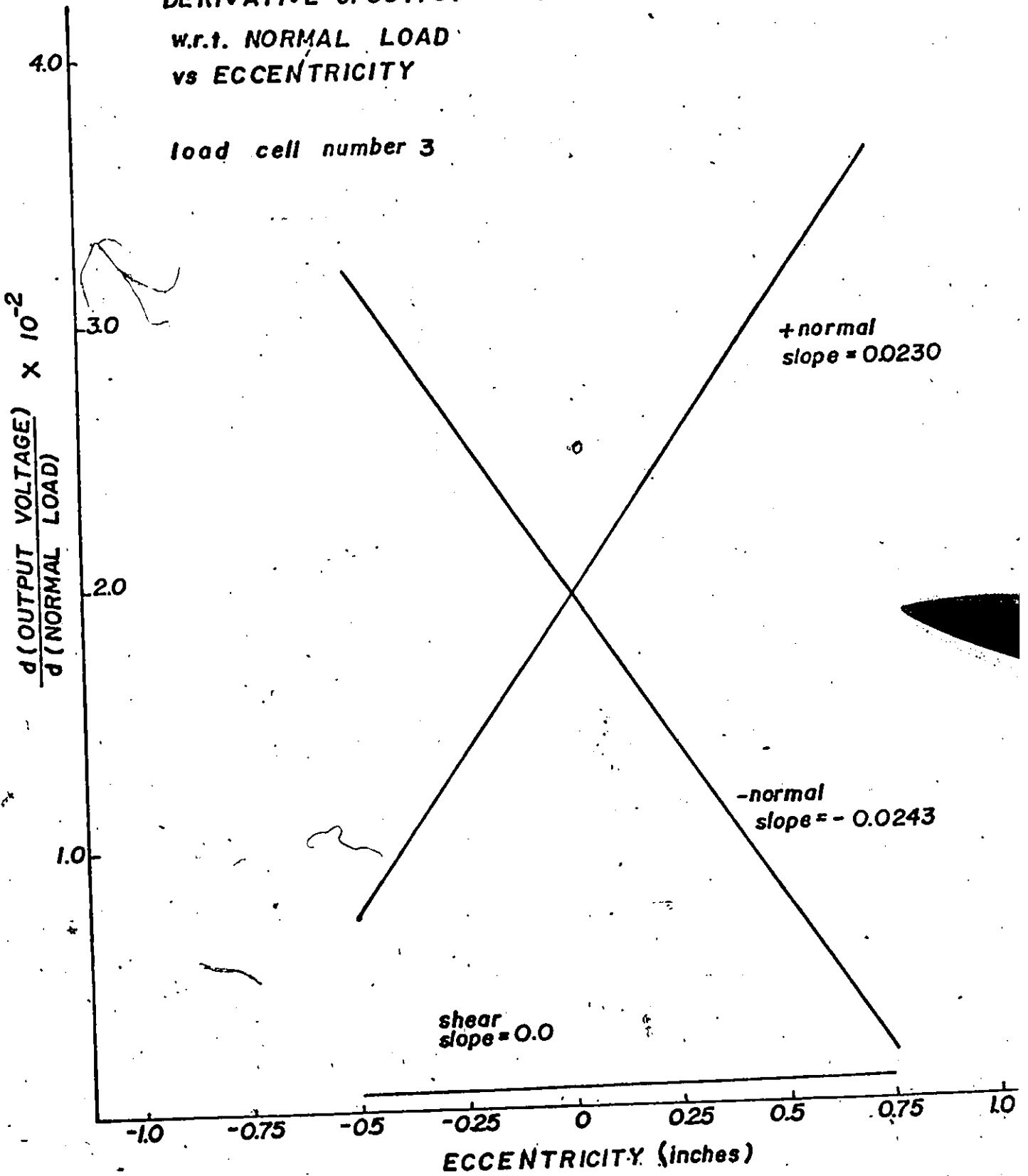

figure 27

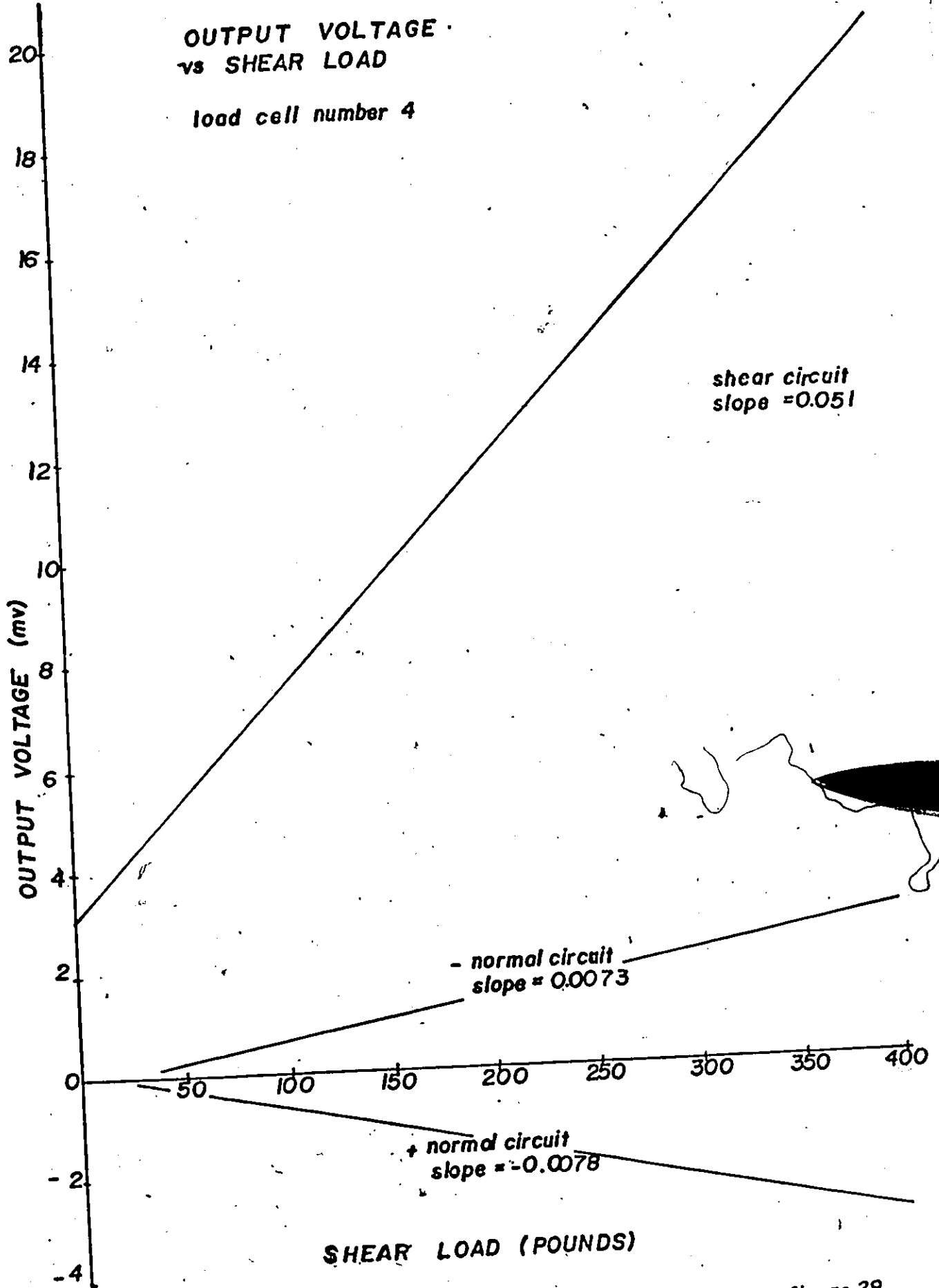

figure 28

OUTPUT VOLTAGE
vs NORMAL LOAD

load cell number 4

eccentricity e (inches)

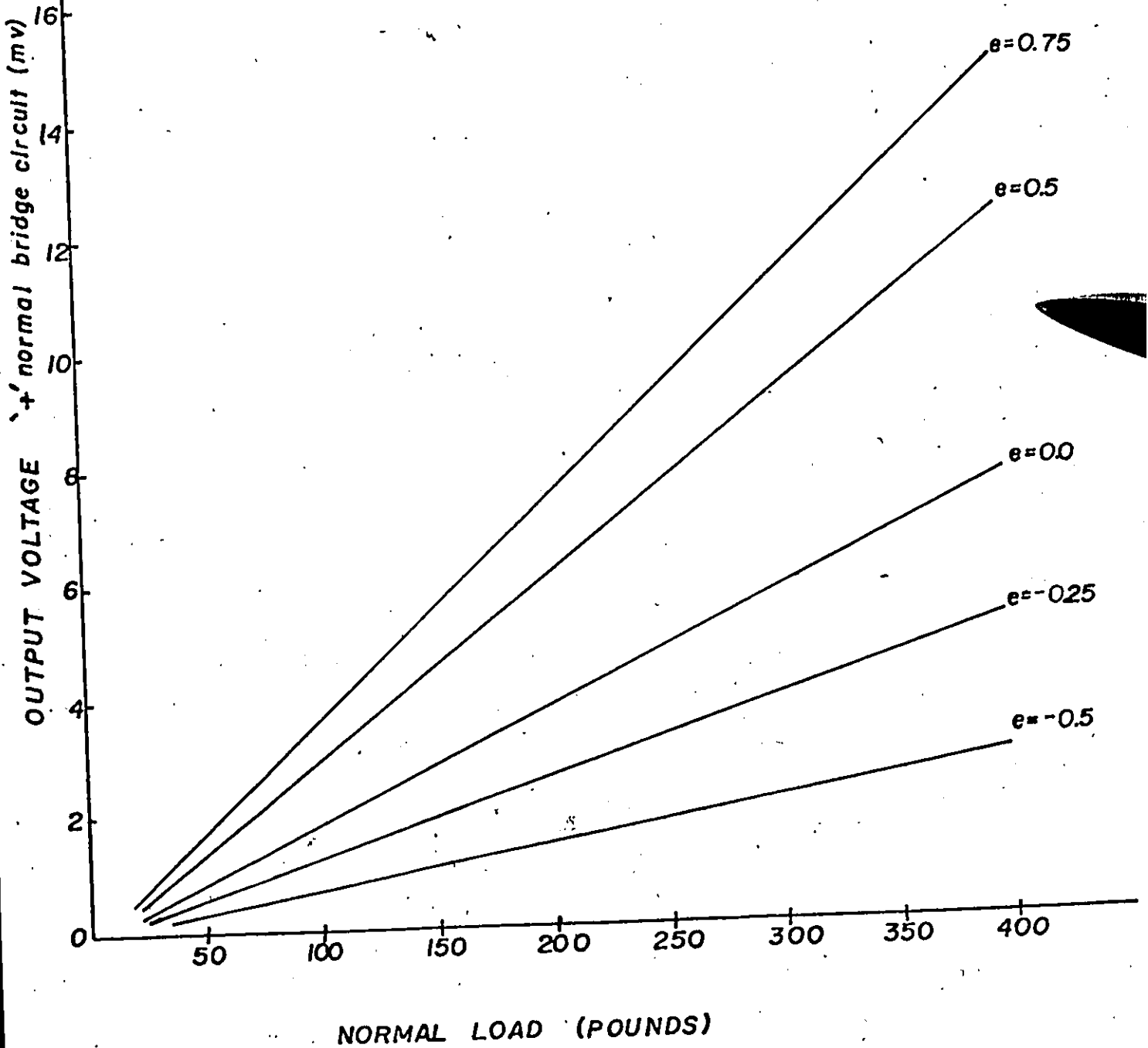

figure 29

**OUTPUT VOLTAGE
vs NORMAL LOAD**

load cell number 4

eccentricity e (inches)

figure 30

**OUTPUT VOLTAGE
vs NORMAL LOAD**

load cell number 4

eccentricity e (inches)

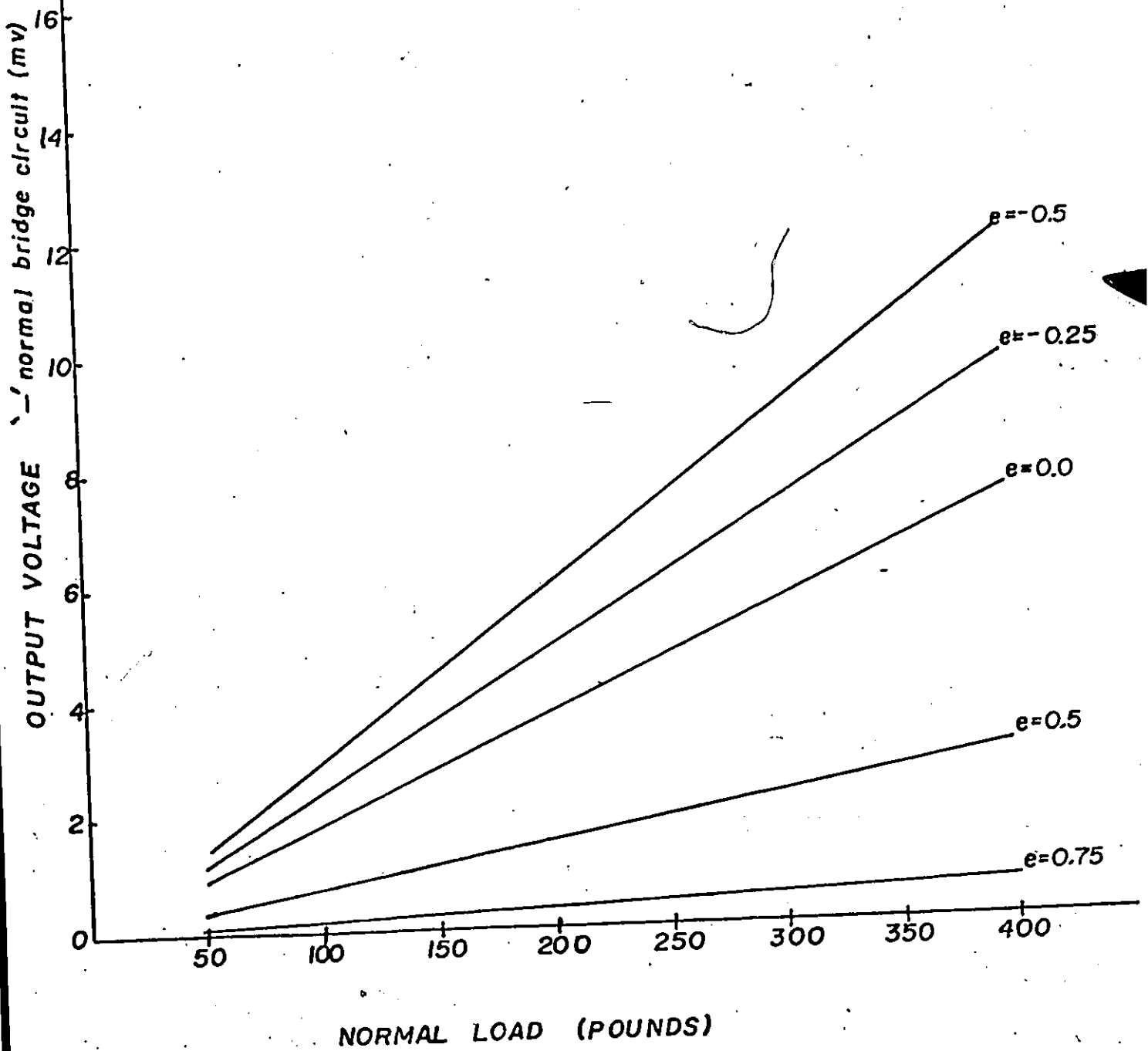
shear bridge circuit (mv)

OUTPUT VOLTAGE

36
34
32
30

0 50 100 150 200 250 300 350 400

NORMAL LOAD (POUNDS)

$e=0.75$

$e=-0.5$

$e=0.5$

figure 31

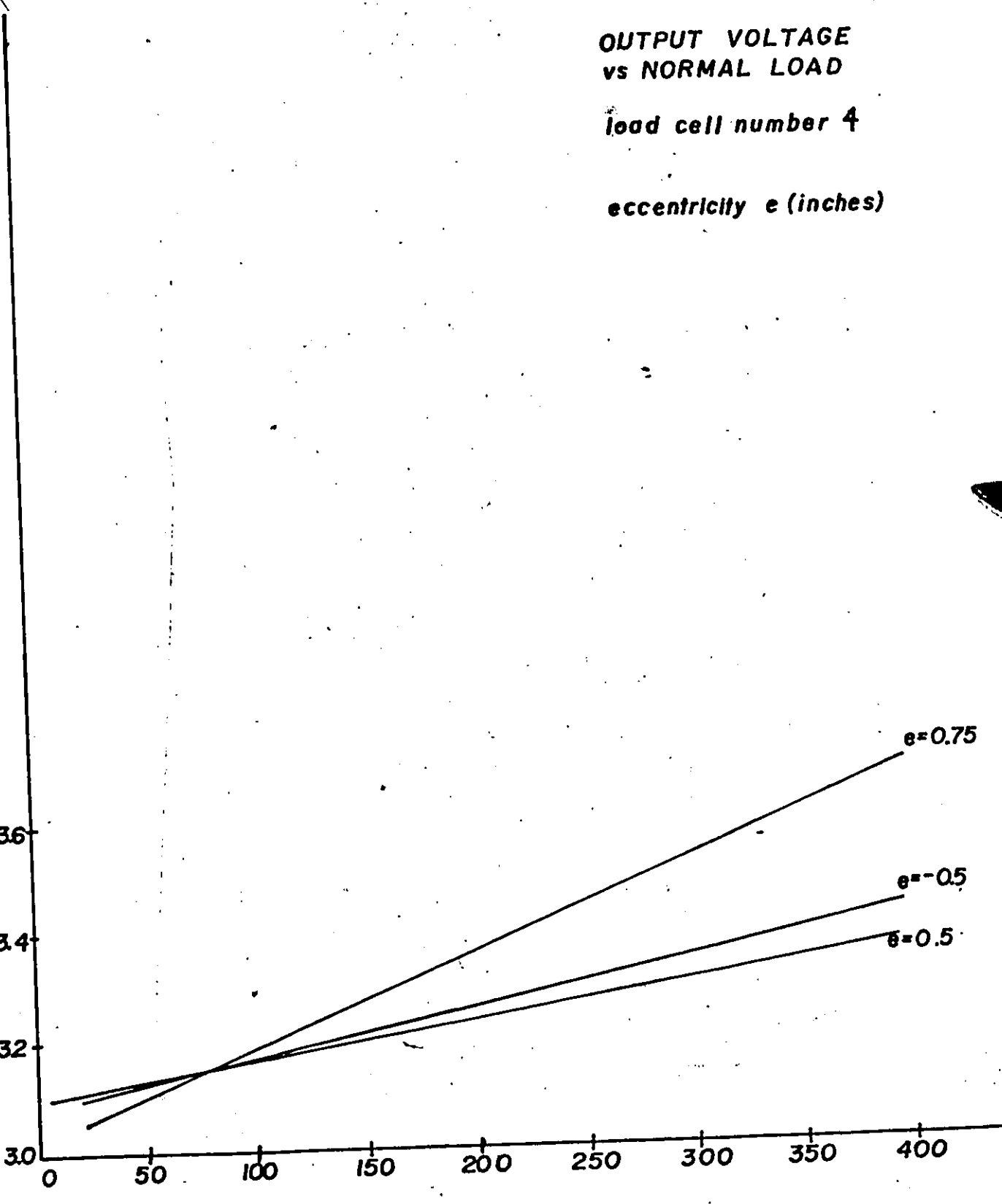

DERIVATIVE of OUTPUT VOLTAGE
w.r.t. NORMAL LOAD
vs ECCENTRICITY

load cell number 4

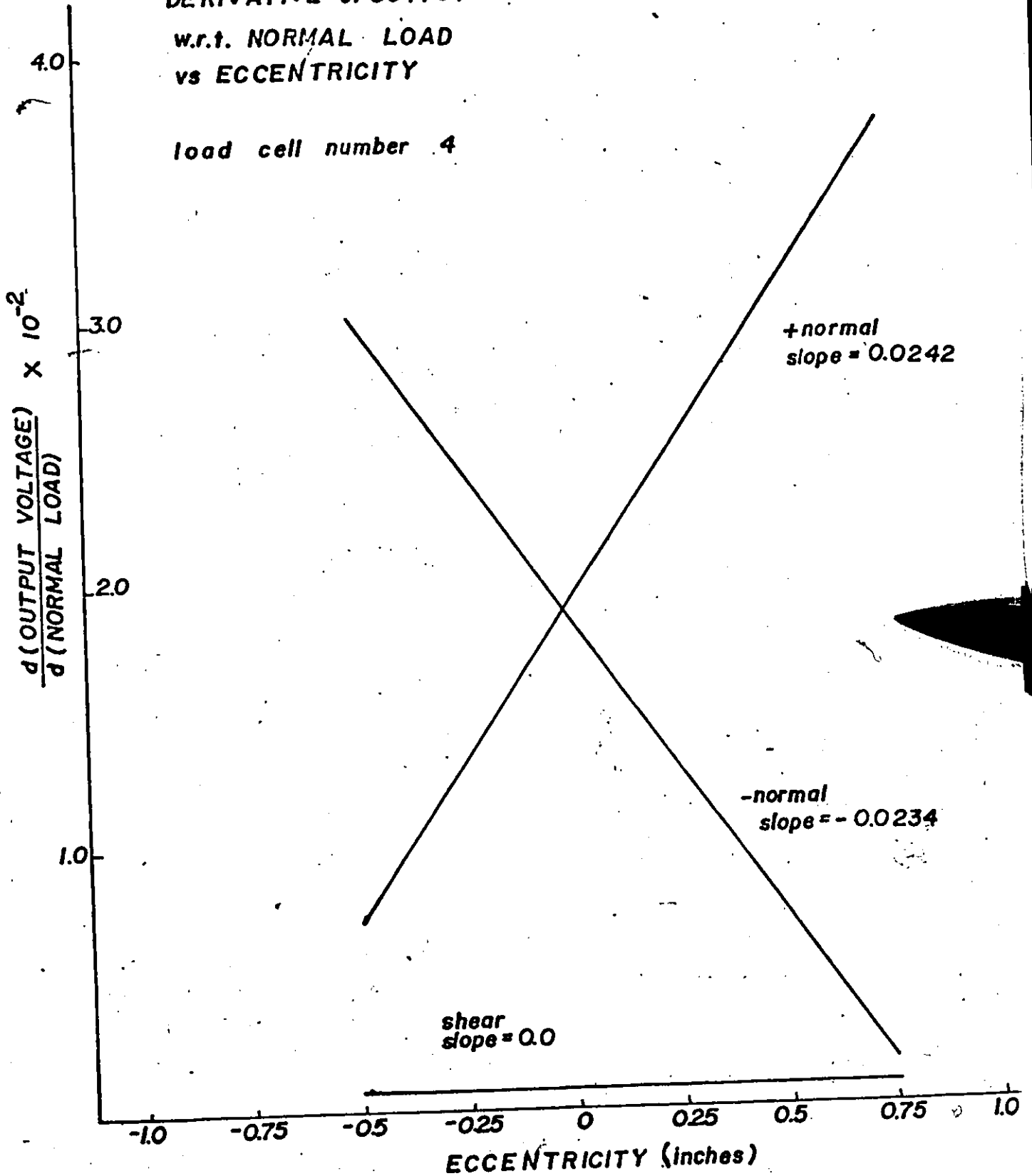

figure 32

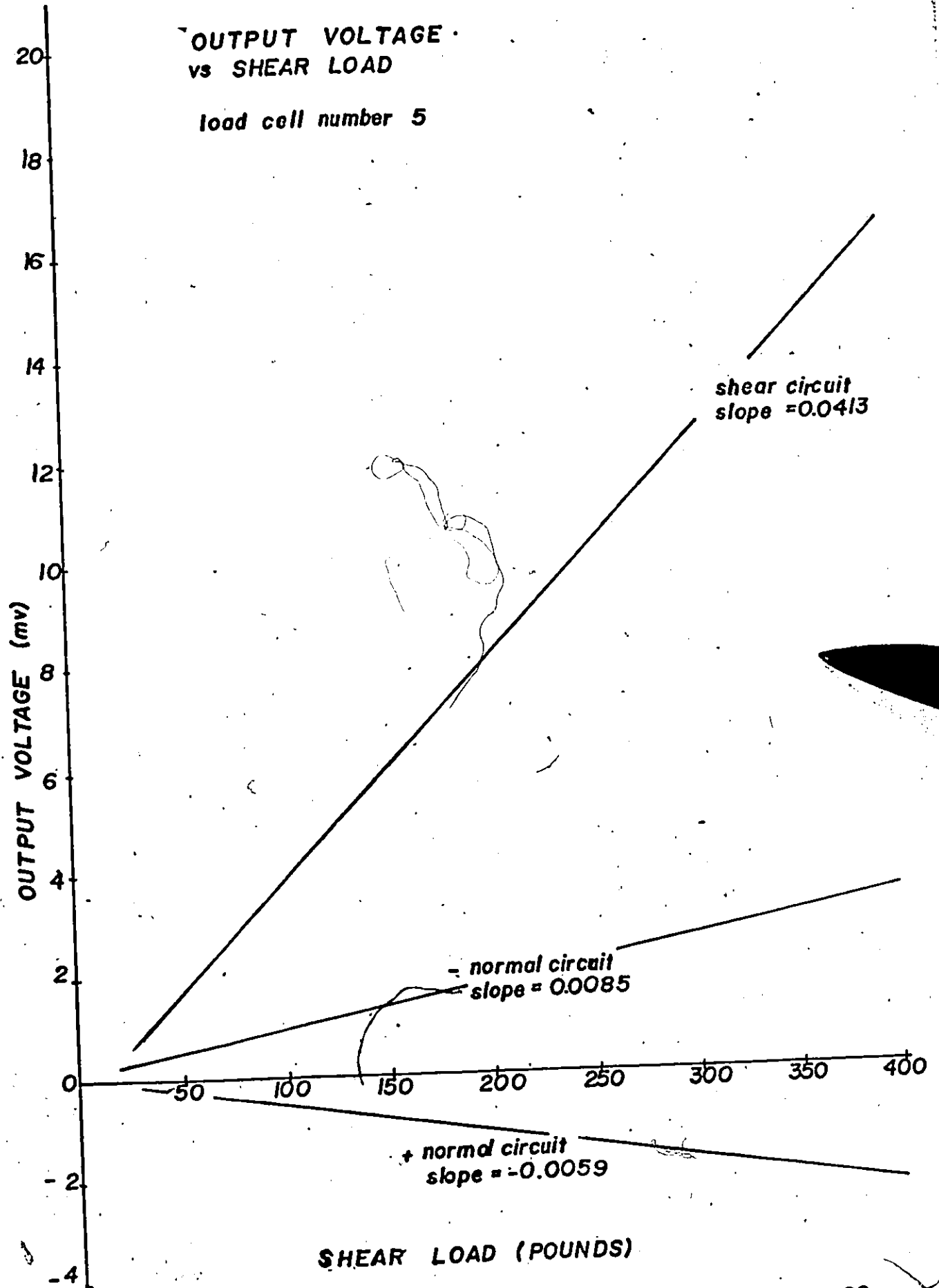

figure 33

OUTPUT VOLTAGE
vs NORMAL LOAD

load cell number 5

eccentricity e (inches)

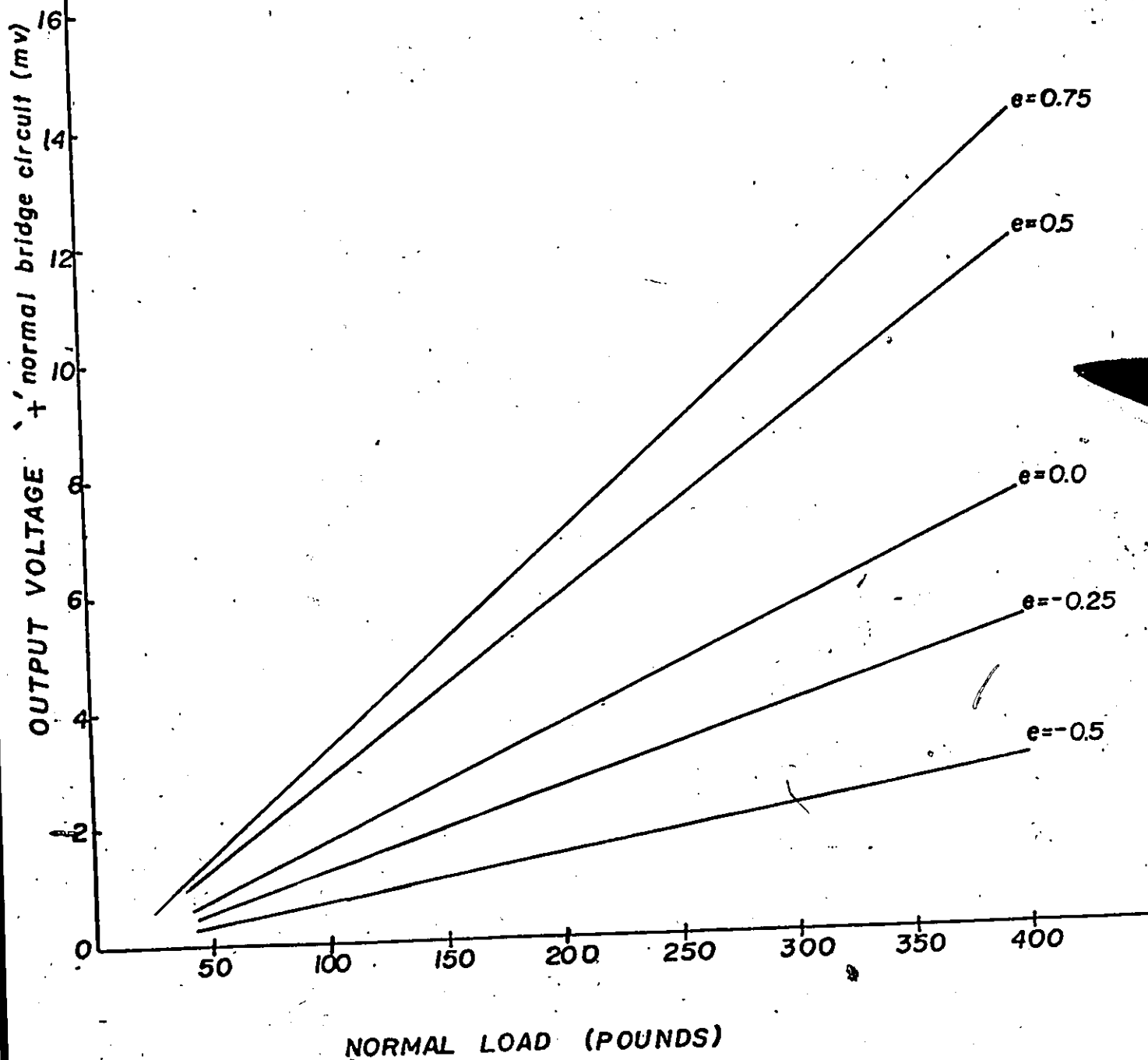

figure 3f

OUTPUT VOLTAGE
vs NORMAL LOAD

load cell number 5

eccentricity e (inches)

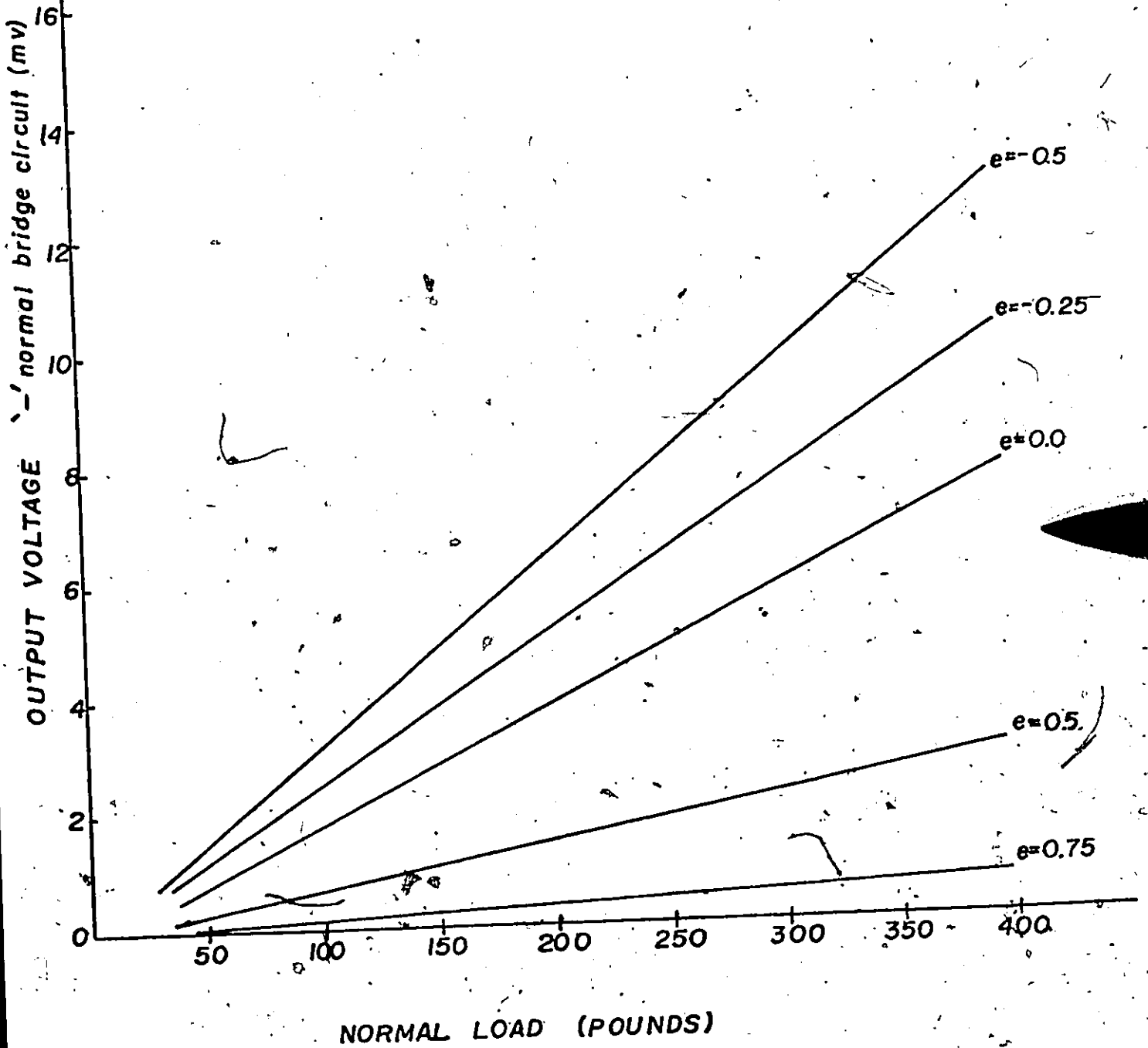

figure 35

OUTPUT VOLTAGE
vs NORMAL LOAD

load cell number 5

eccentricity e (inches)

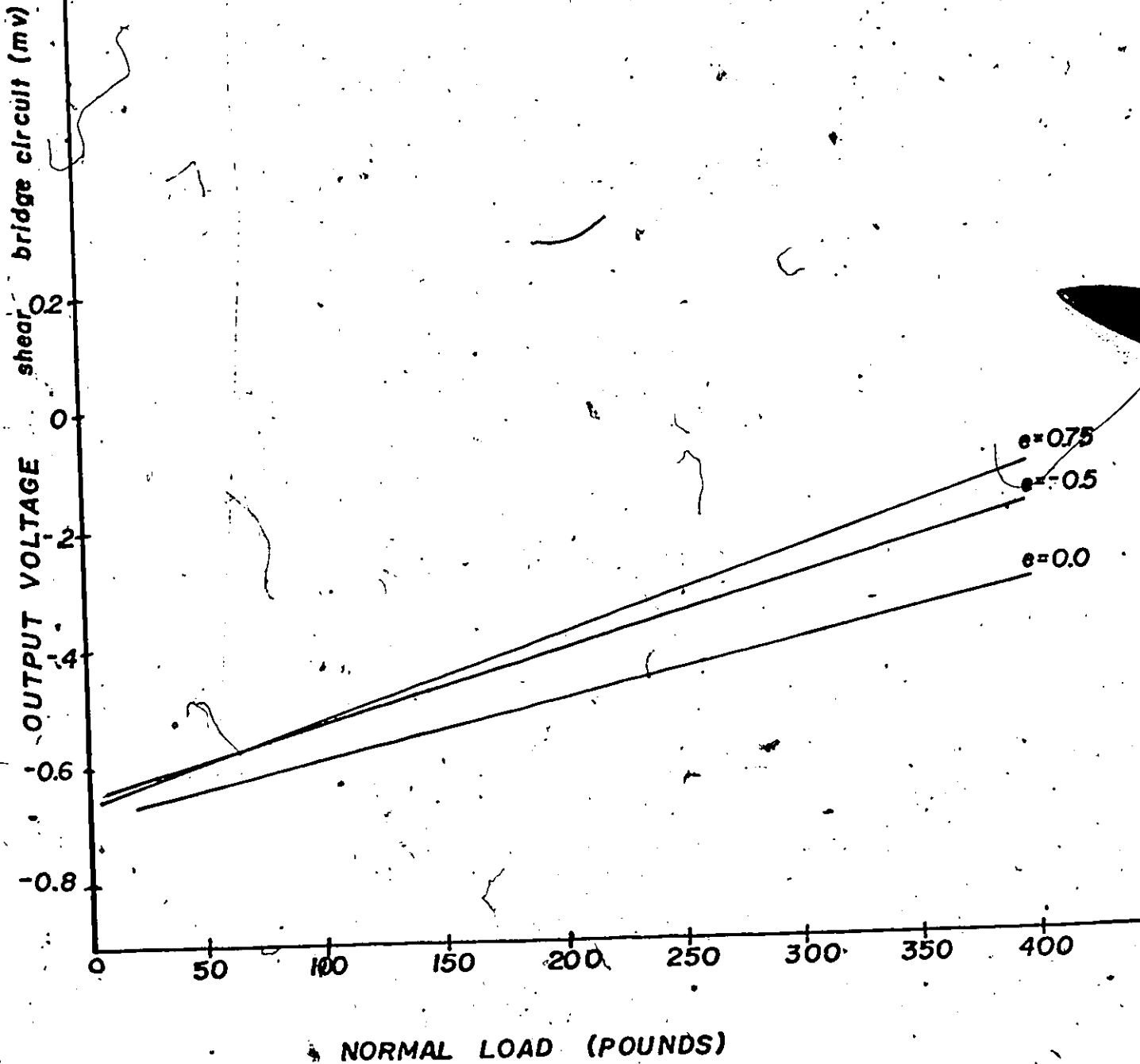

figure 36

DERIVATIVE of OUTPUT VOLTAGE
w.r.t. NORMAL LOAD
vs ECCENTRICITY

load cell number 5

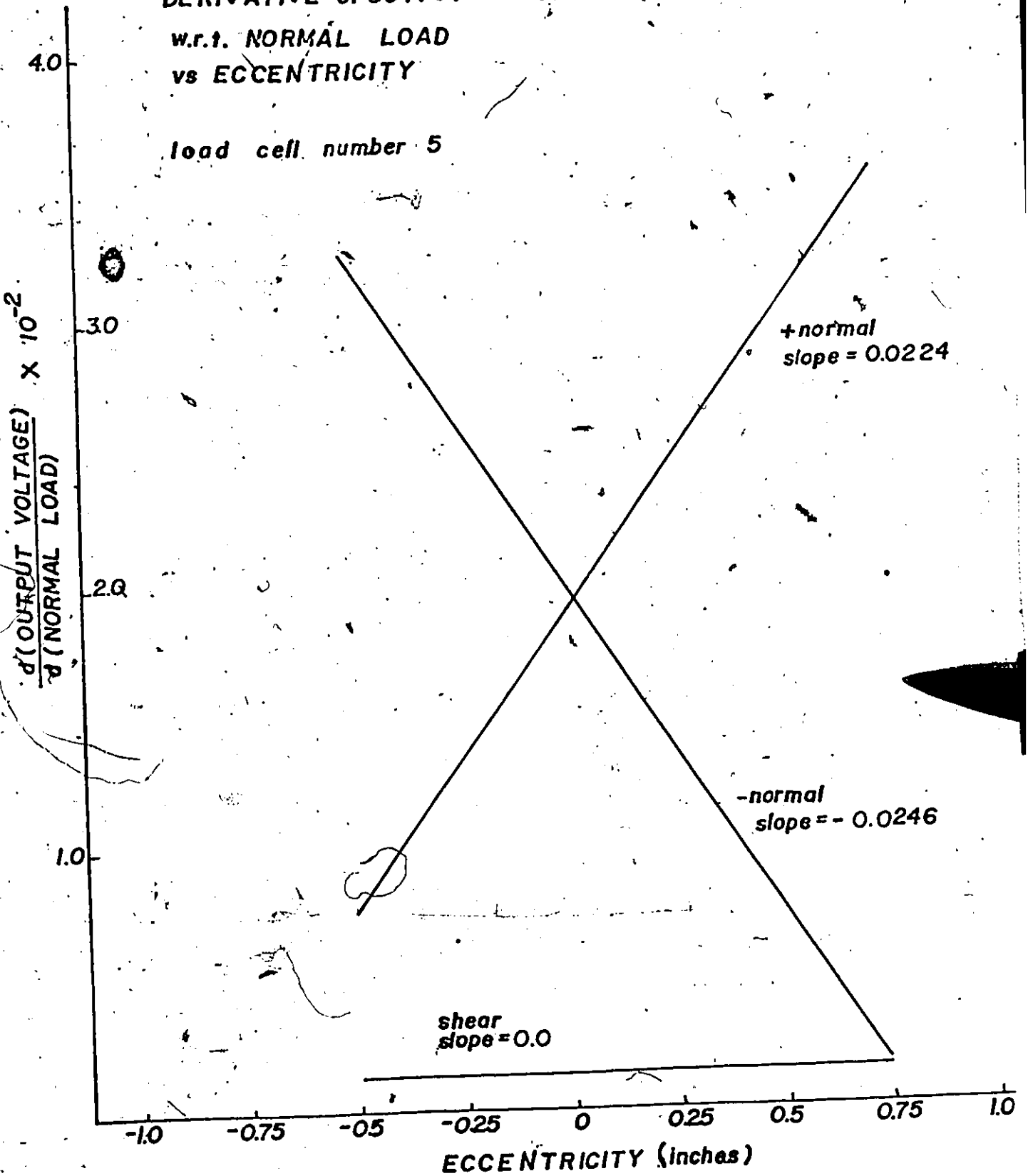

figure 37

OUTPUT VOLTAGE
vs SHEAR LOAD

load cell number 6

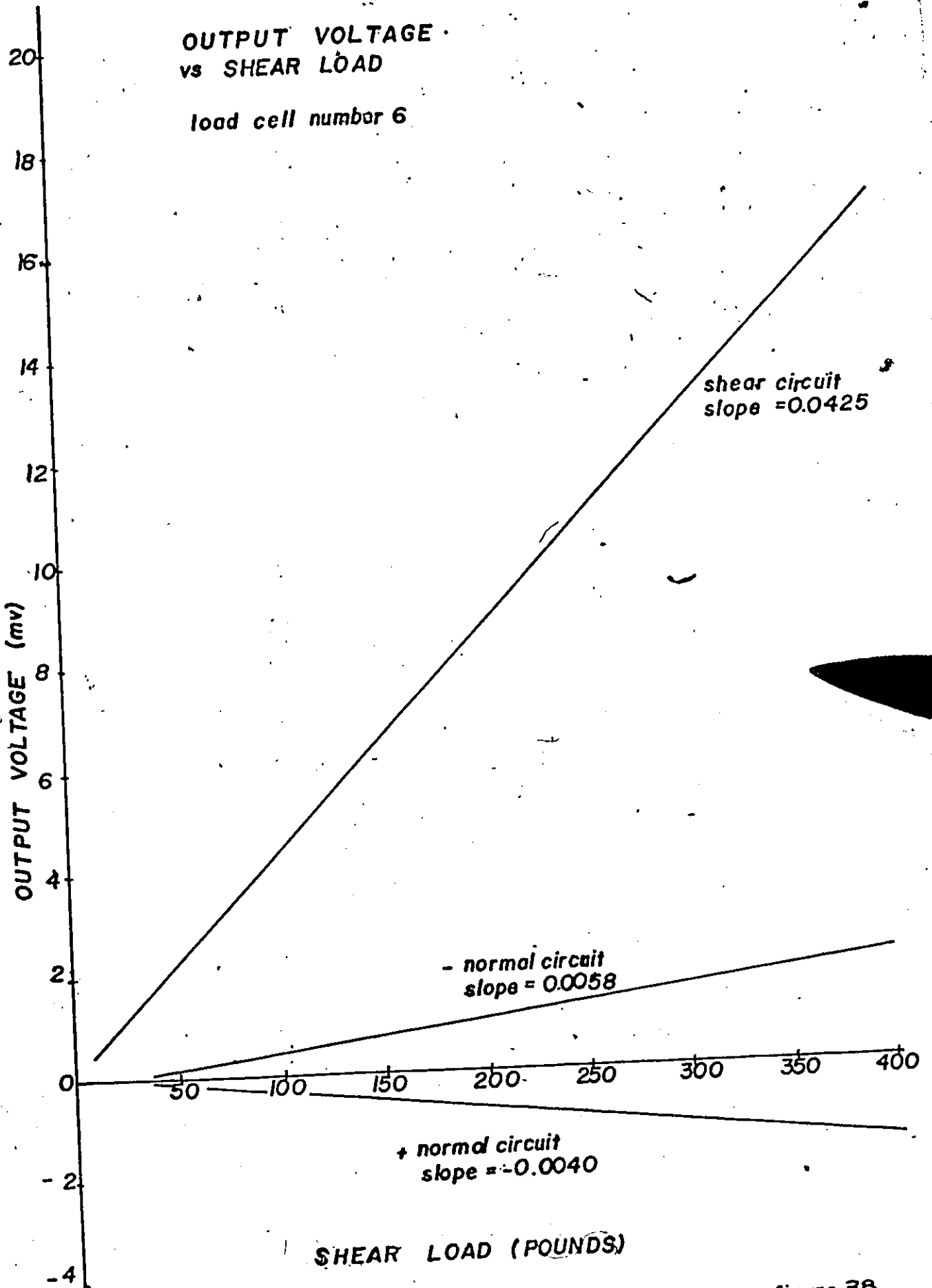

figure 38

OUTPUT VOLTAGE vs NORMAL LOAD

load cell number 6

eccentricity e (inches)

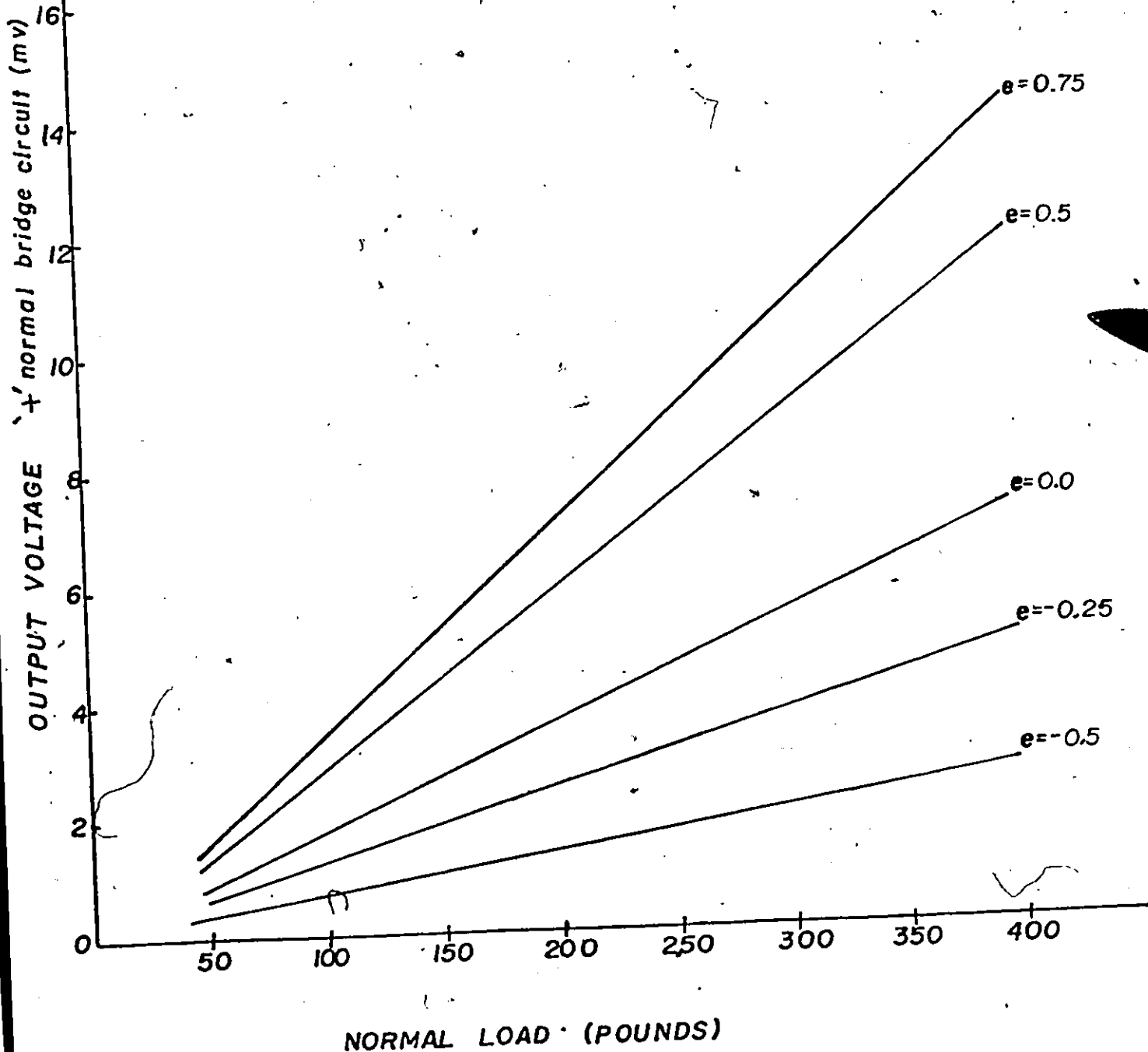

figure 39

OUTPUT VOLTAGE
vs NORMAL LOAD

load cell number 6

eccentricity e (inches)

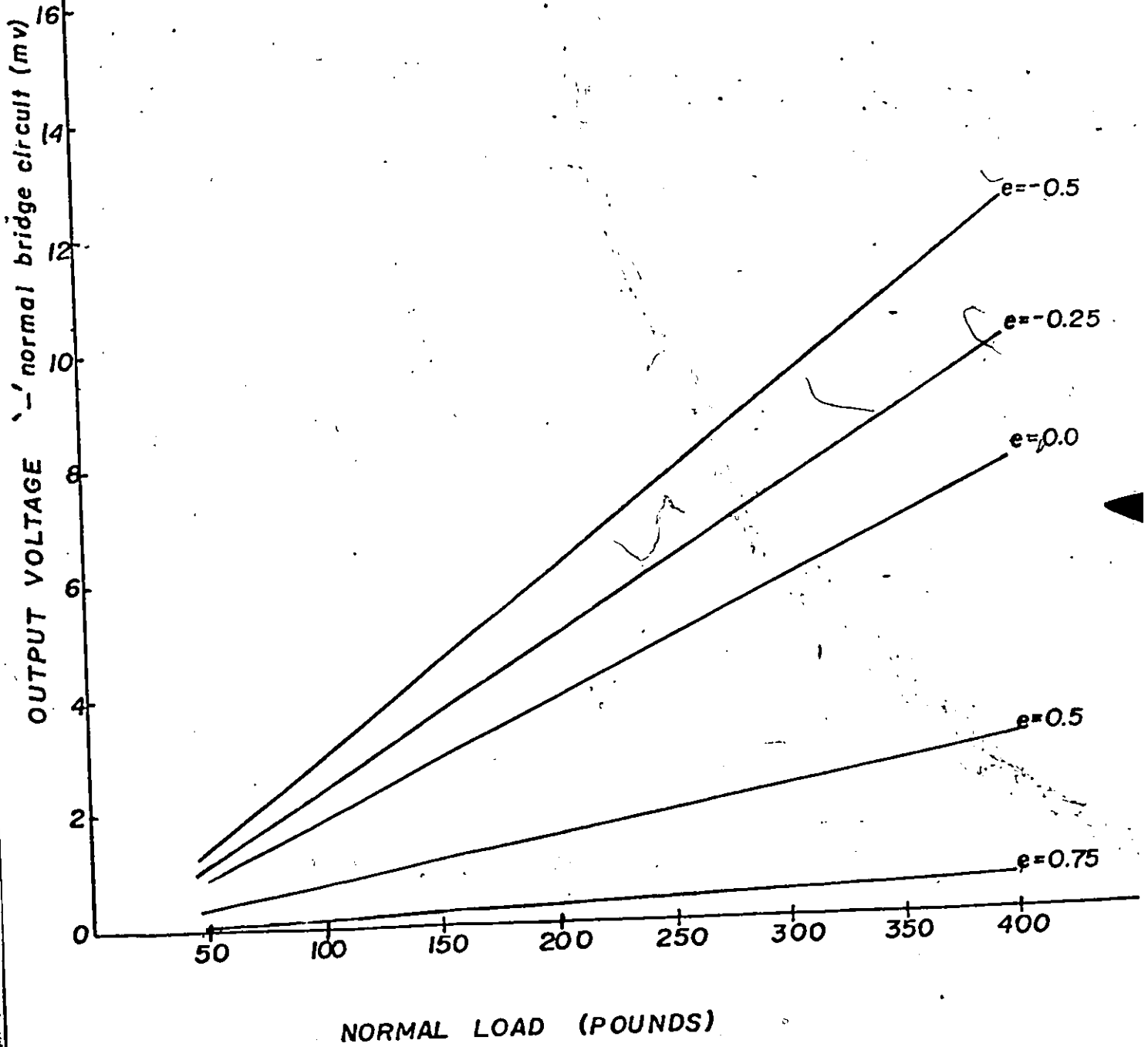

figure 40

OUTPUT VOLTAGE
vs NORMAL LOAD

load cell number 6

eccentricity e (inches)

shear bridge circuit (mv)

OUTPUT VOLTAGE

0.4
0.2
0
-0.2

50 100 150 200 250 300 350 400

NORMAL LOAD (POUNDS)

$e=0.75$

$e=-0.5$

$e=0.5$

figure 41

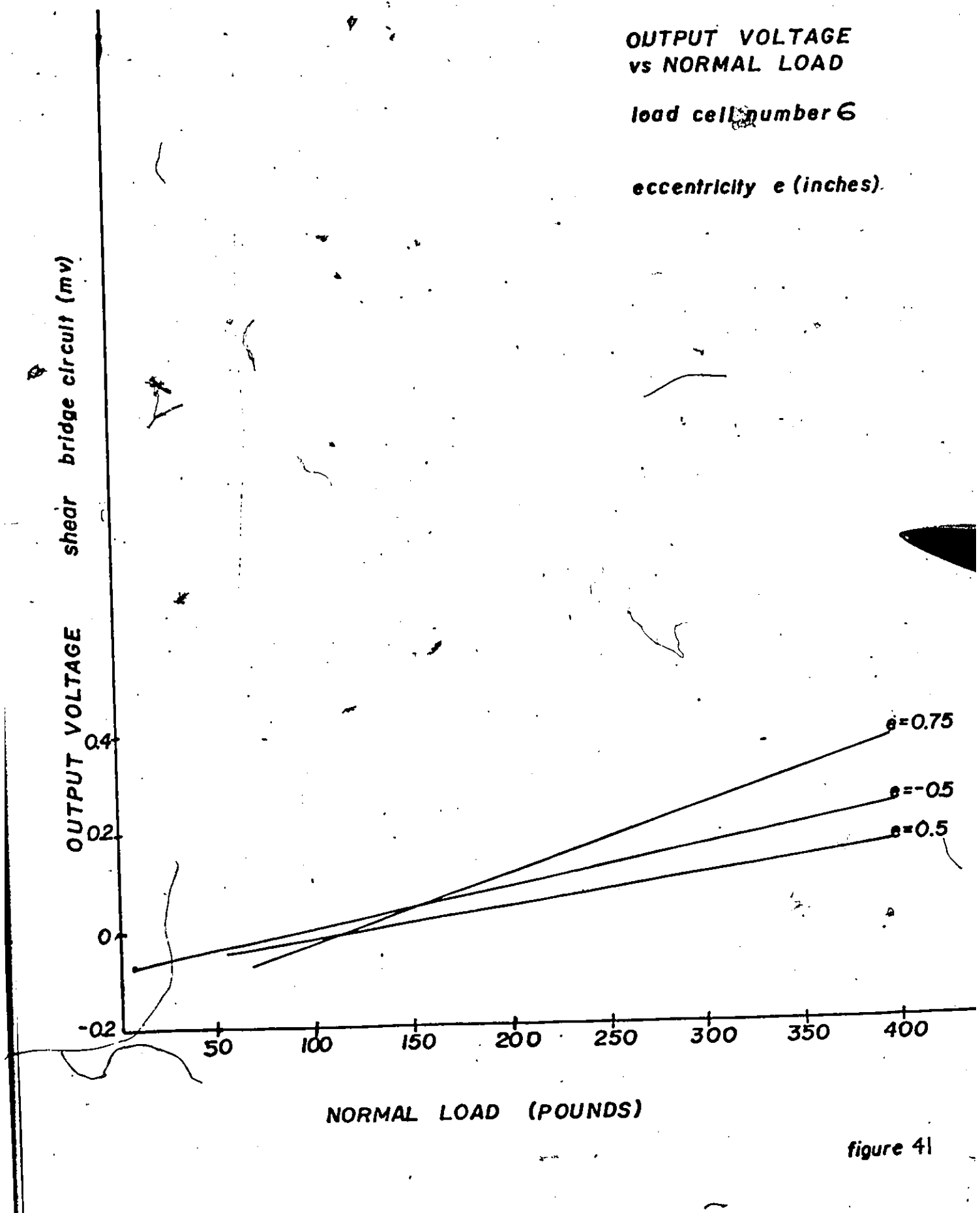

DERIVATIVE of OUTPUT VOLTAGE
w.r.t. NORMAL LOAD
vs ECCENTRICITY

load cell number 6

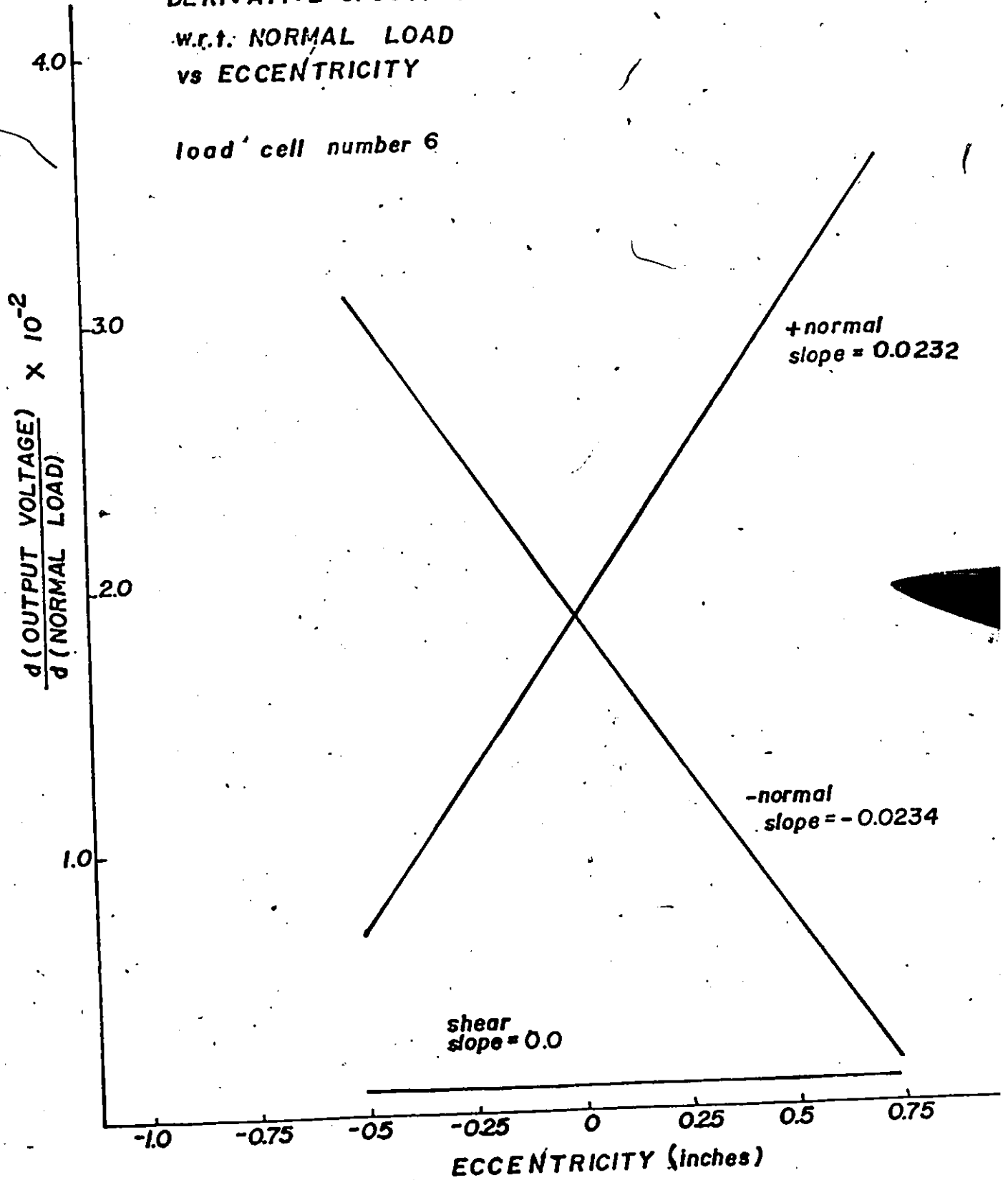
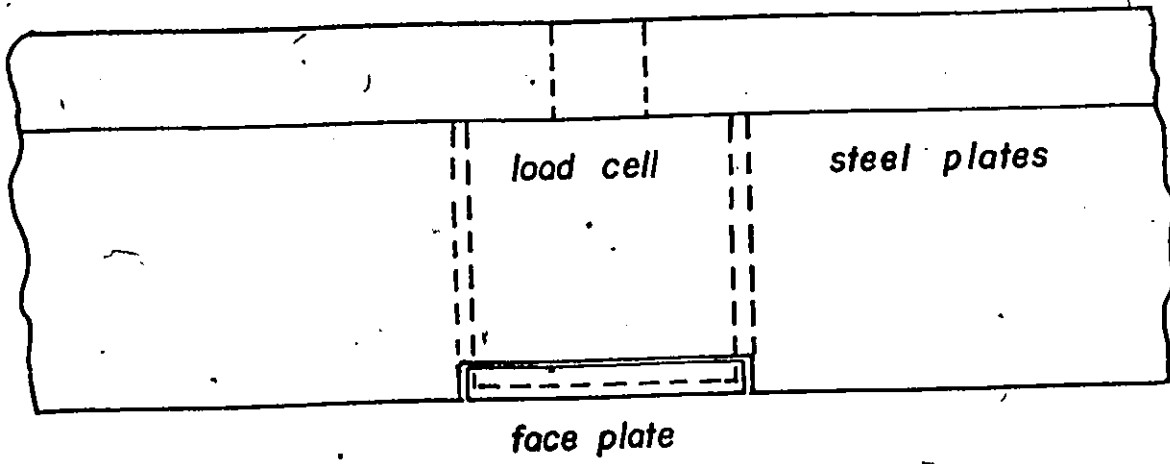
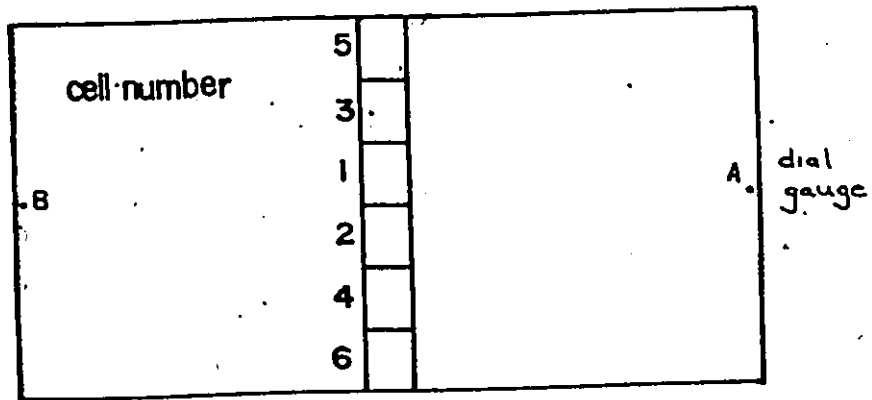

figure 42



CELL in FOOTING (side view)

figure 43



FOOTING BASE SHOWING CELL POSITIONING

figure 44

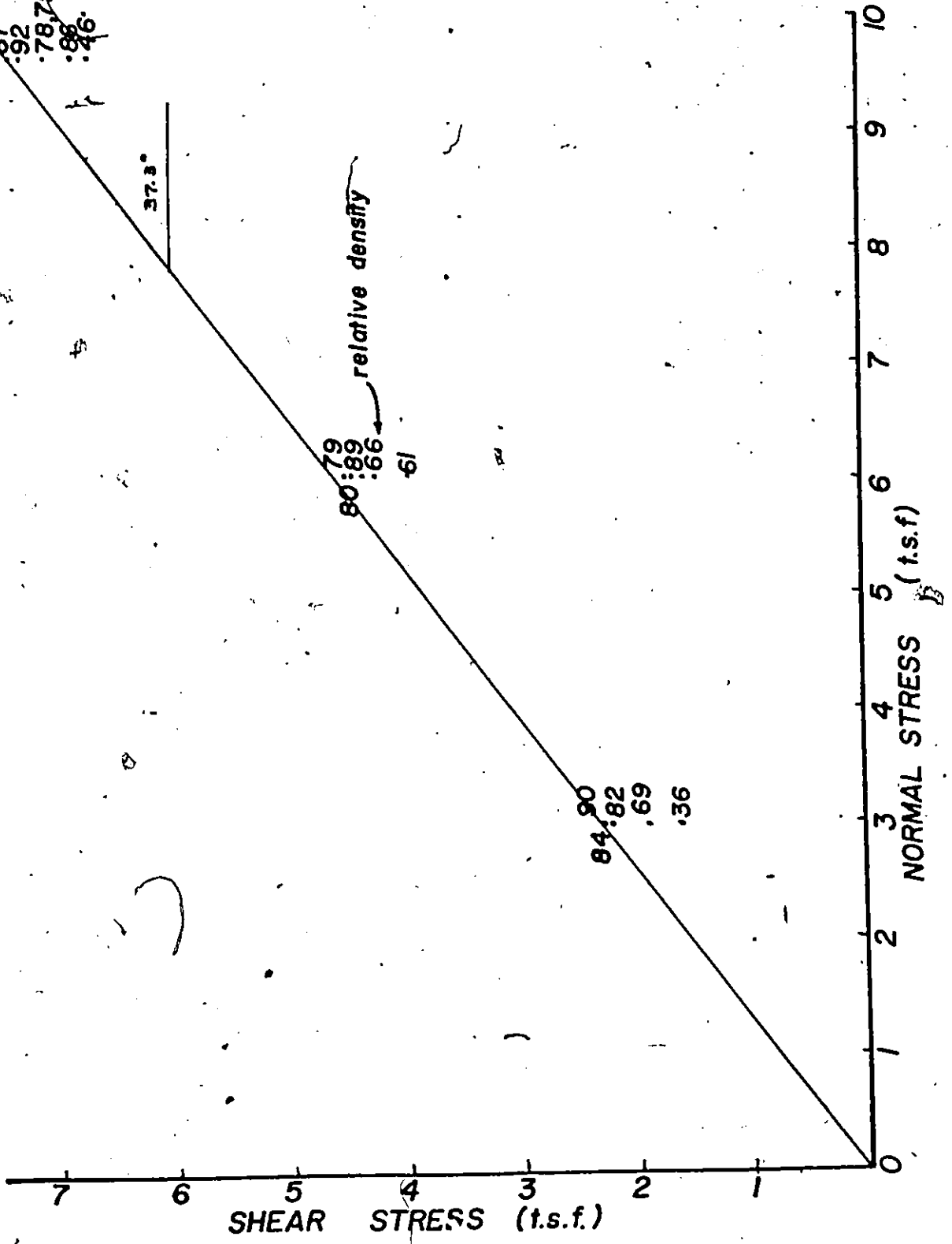

SHEAR vs NORMAL STRESS (epoxy-sand surface)

figure 45

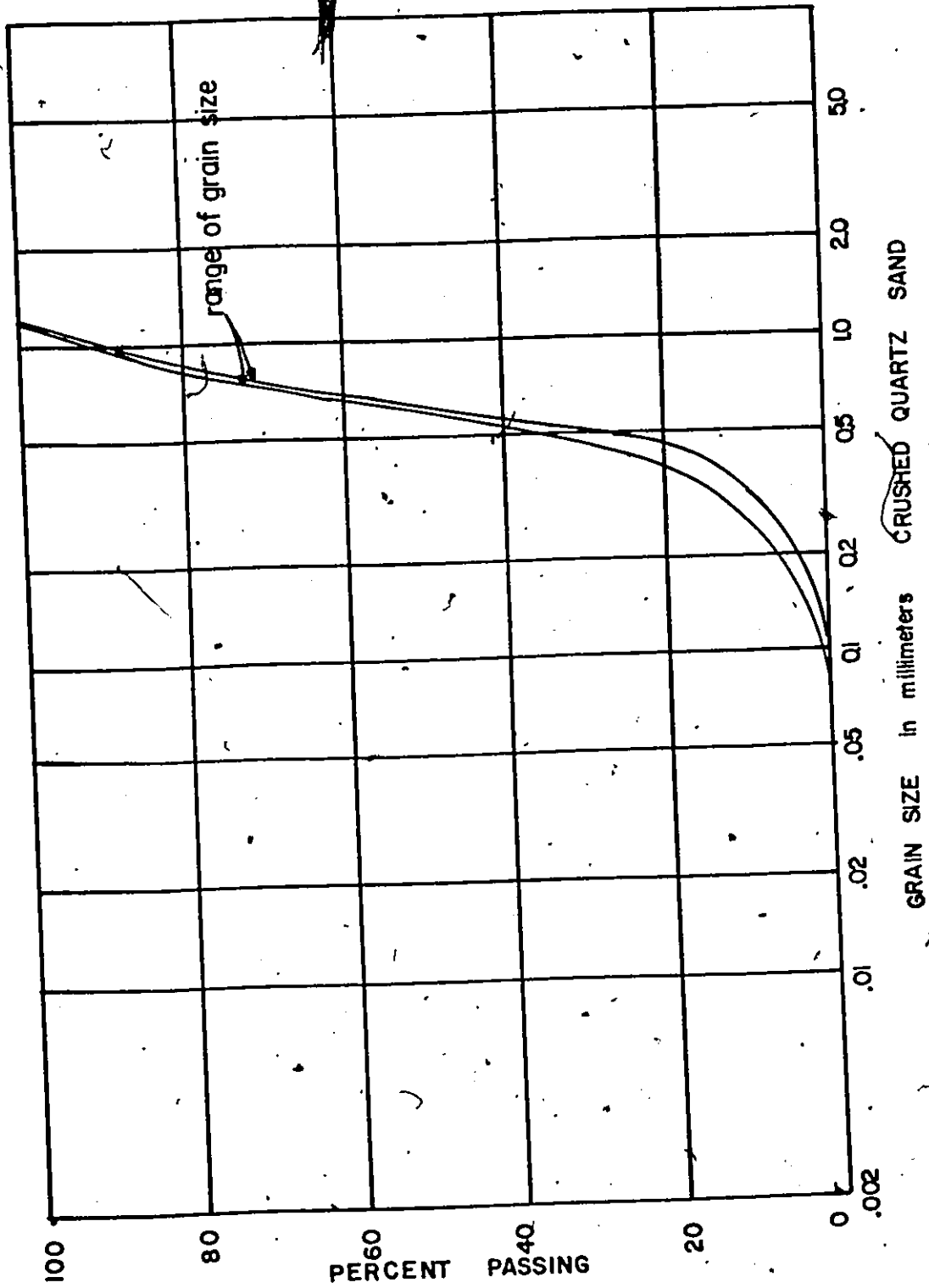
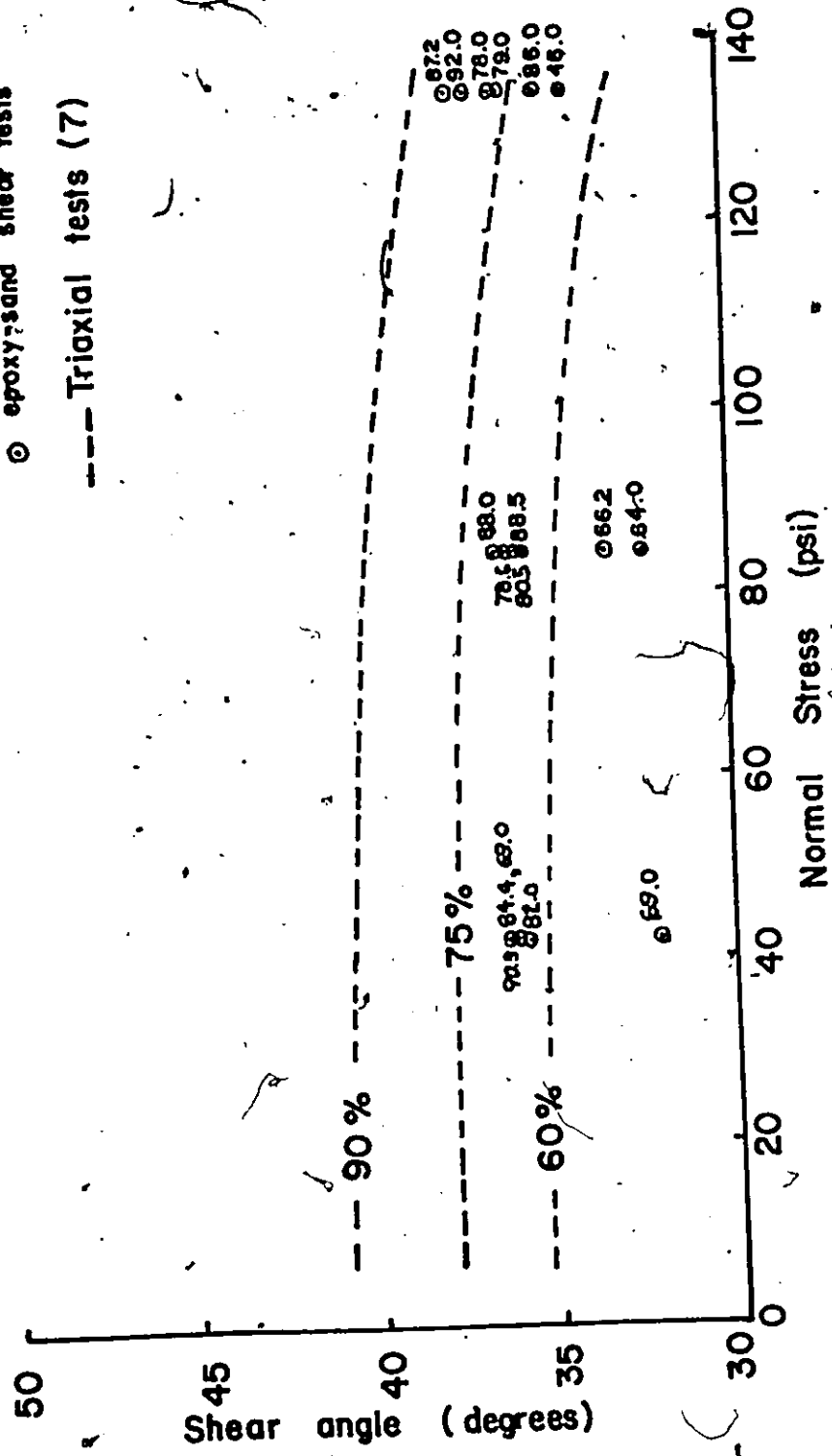

figure 46

○ epoxy-sand shear tests
 --- Triaxial tests (7)



Normal Stress vs Shear Angle

figure 47

CALIBRATION OF
LOADING JACK

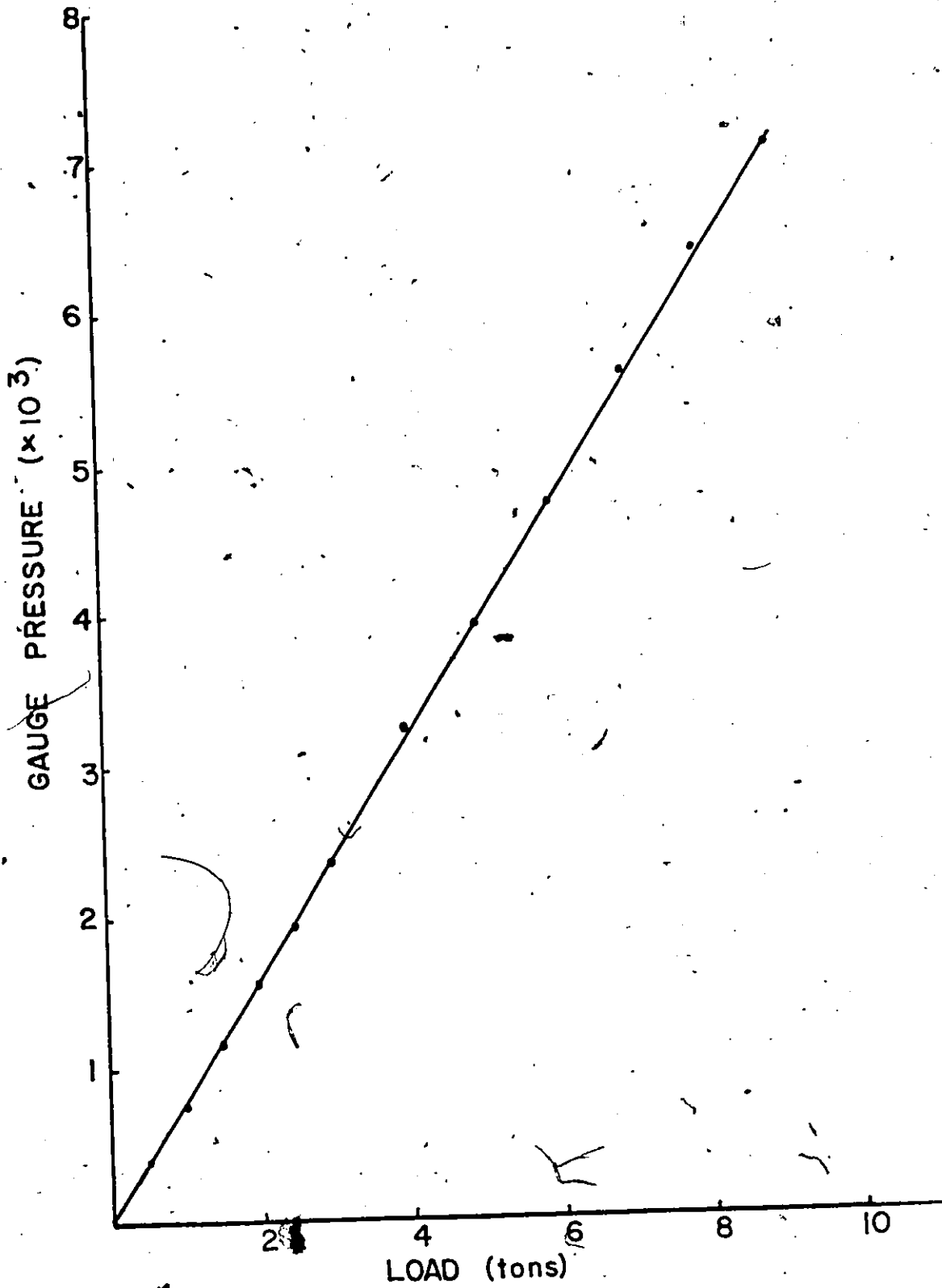

figure 48

NORMAL LOAD vs
OUTPUT VOLTAGE

cell number 1

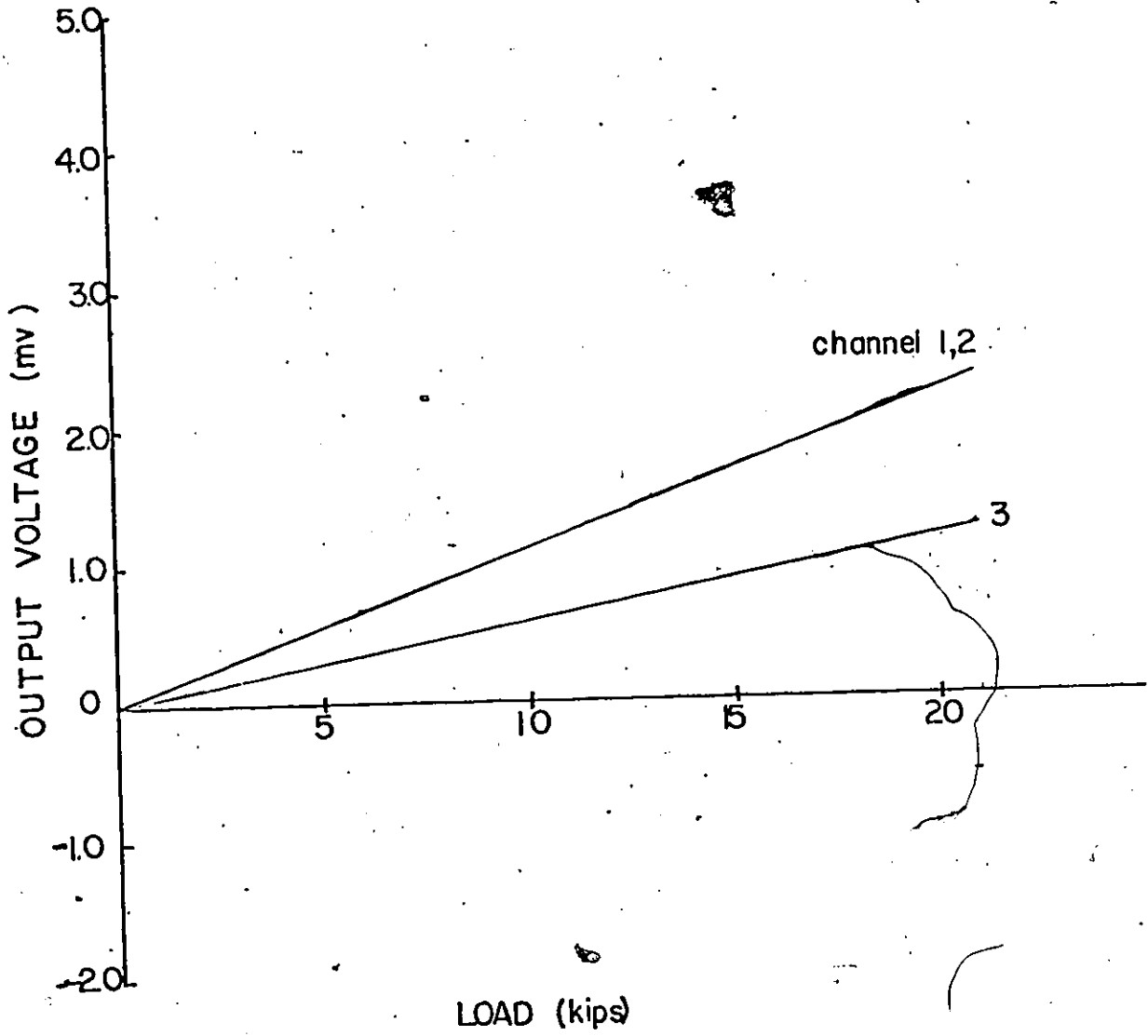

figure 49

NORMAL LOAD vs
OUTPUT VOLTAGE
cell number 2

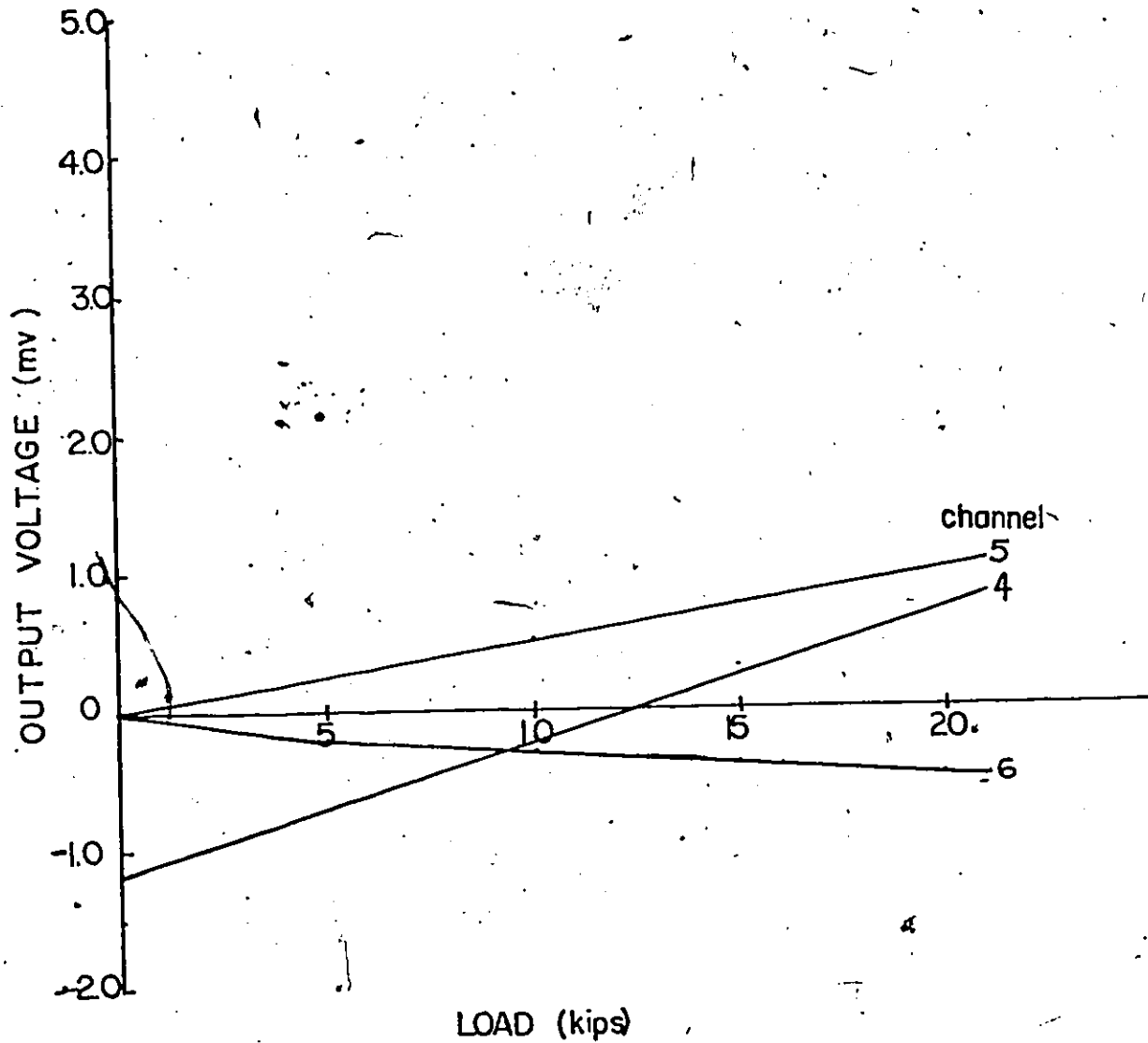

figure 50

NORMAL LOAD vs
OUTPUT VOLTAGE

cell number 3

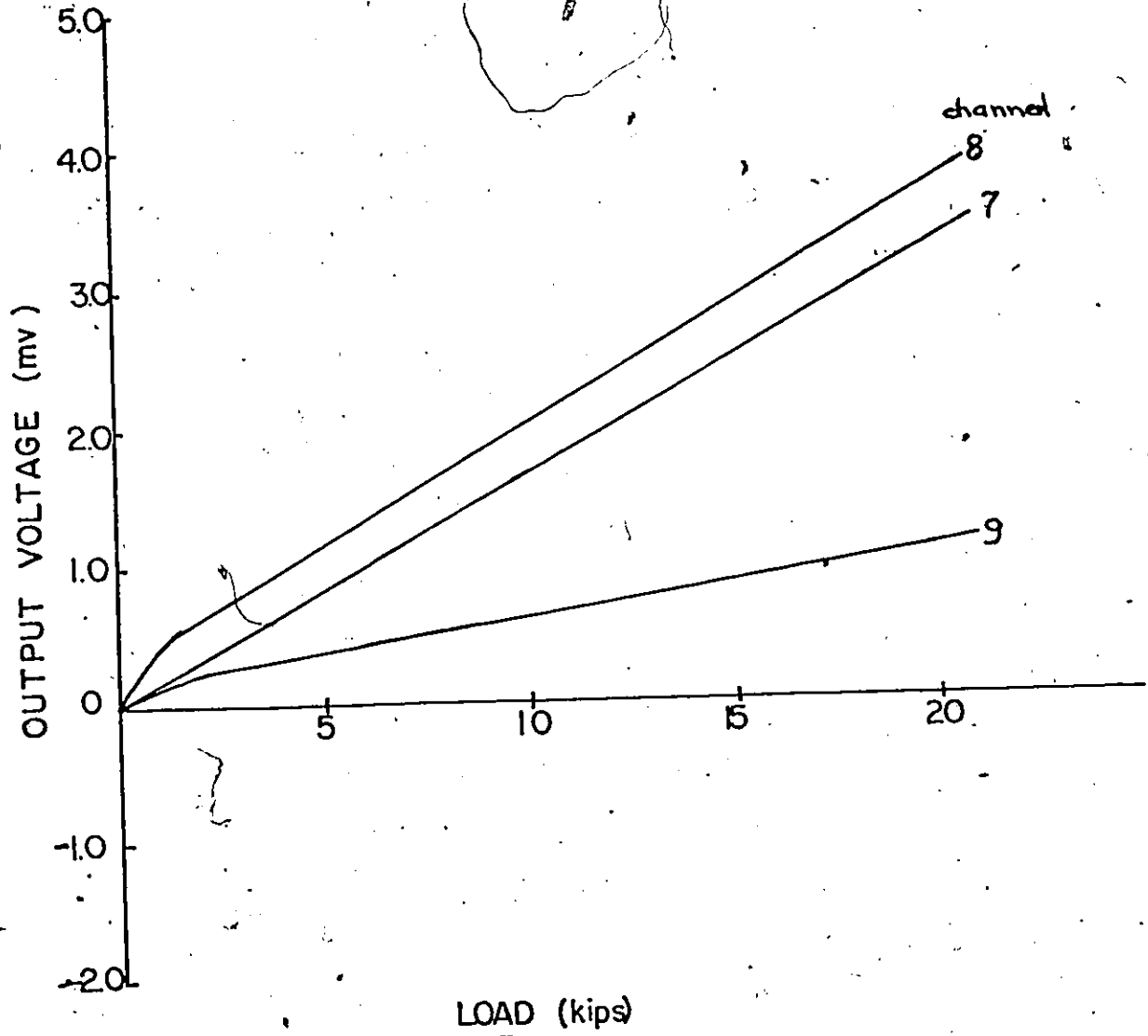

figure 5/

NORMAL LOAD vs
OUTPUT VOLTAGE

cell number 4

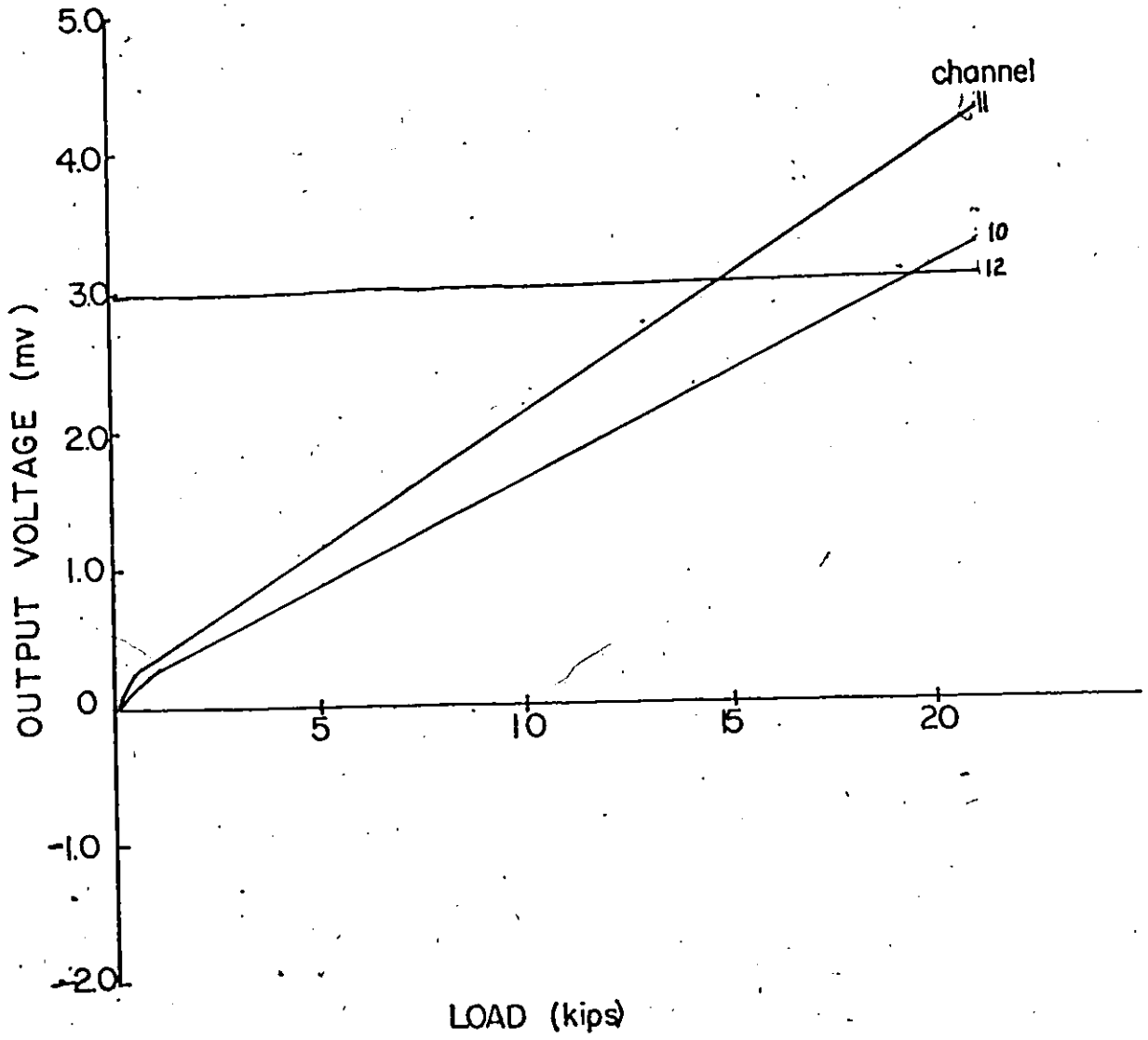

figure 52

NORMAL LOAD vs
OUTPUT VOLTAGE

cell number 5

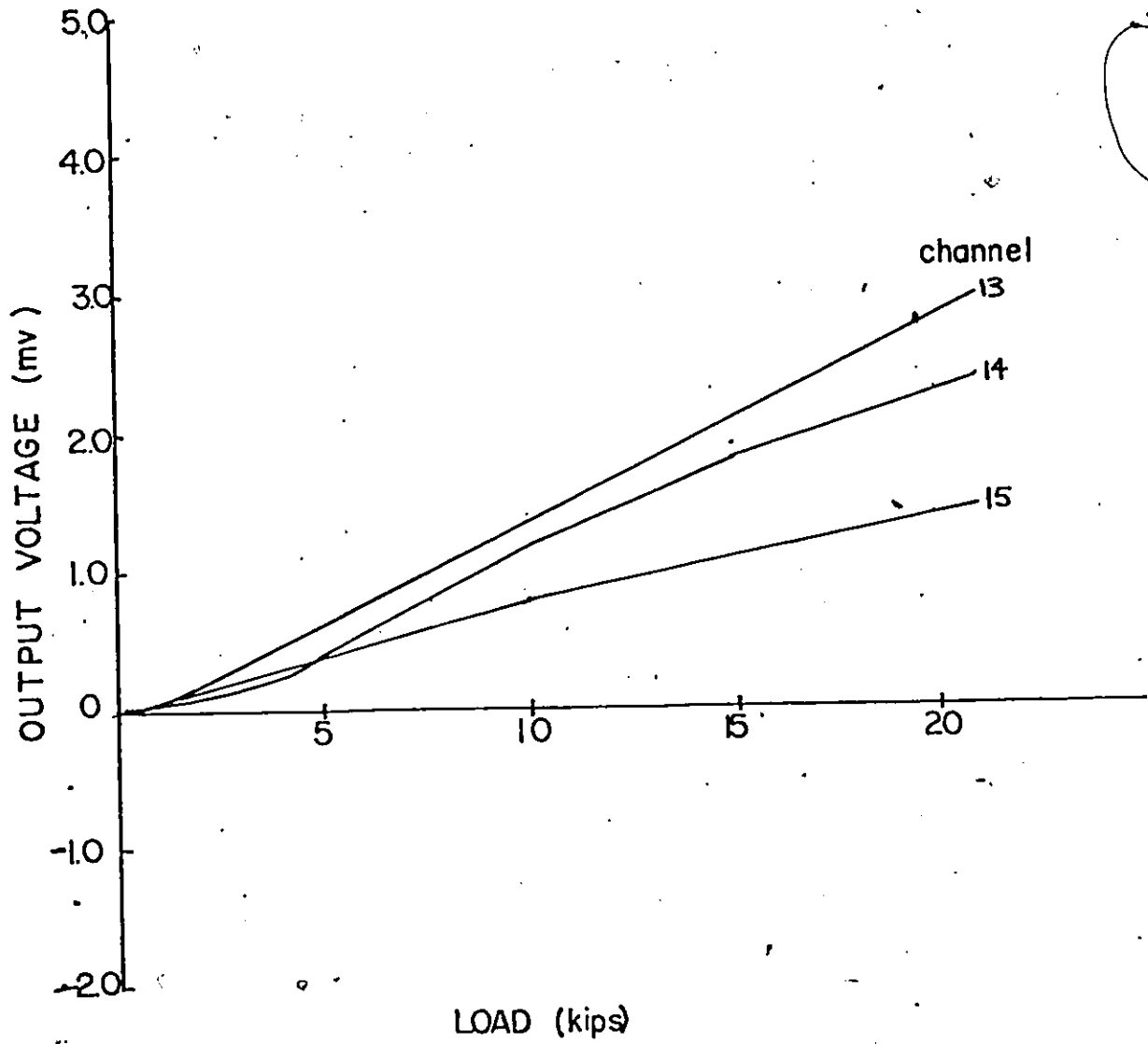

figure 53

NORMAL LOAD vs
OUTPUT VOLTAGE
cell number 6

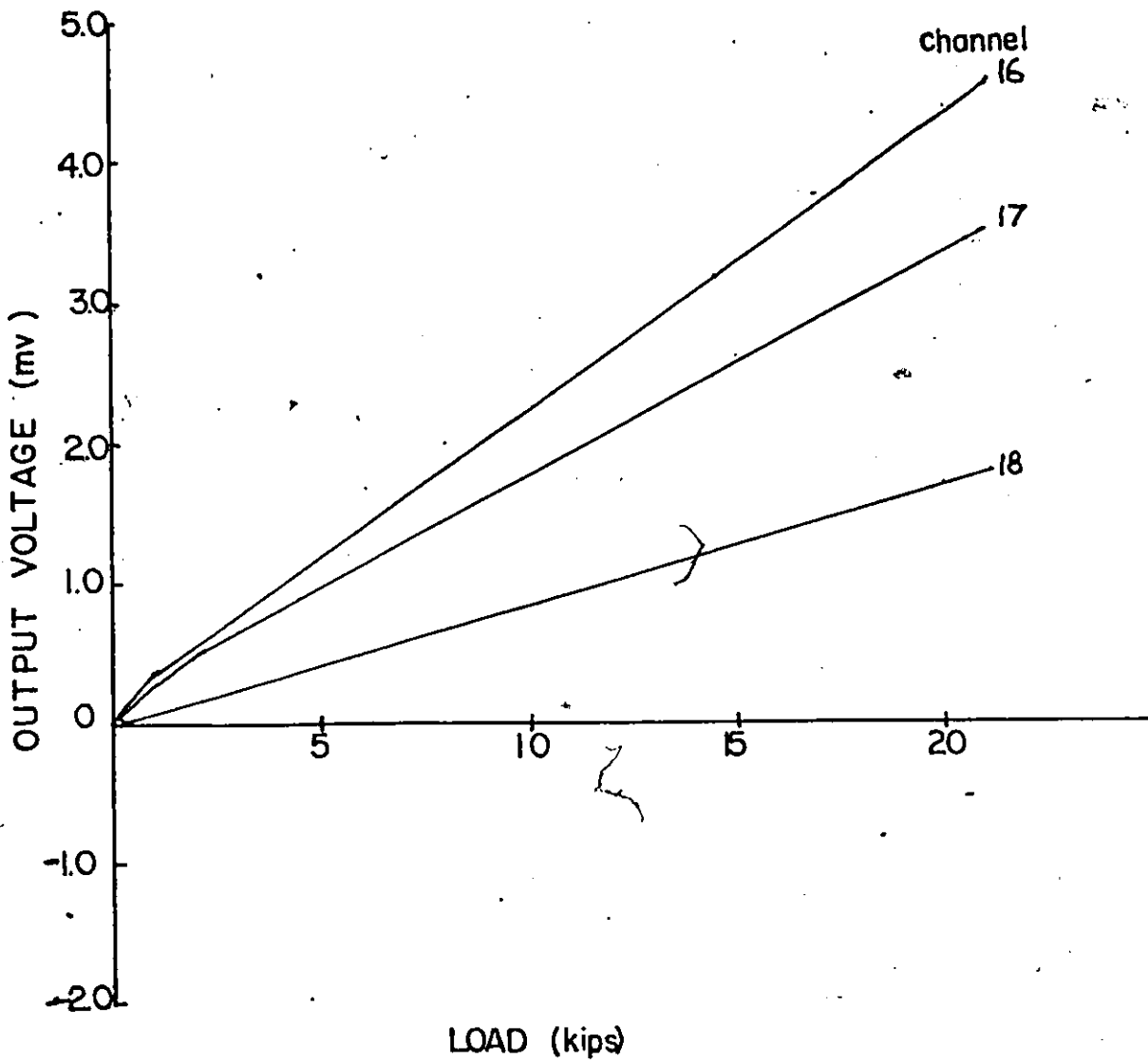

figure 54

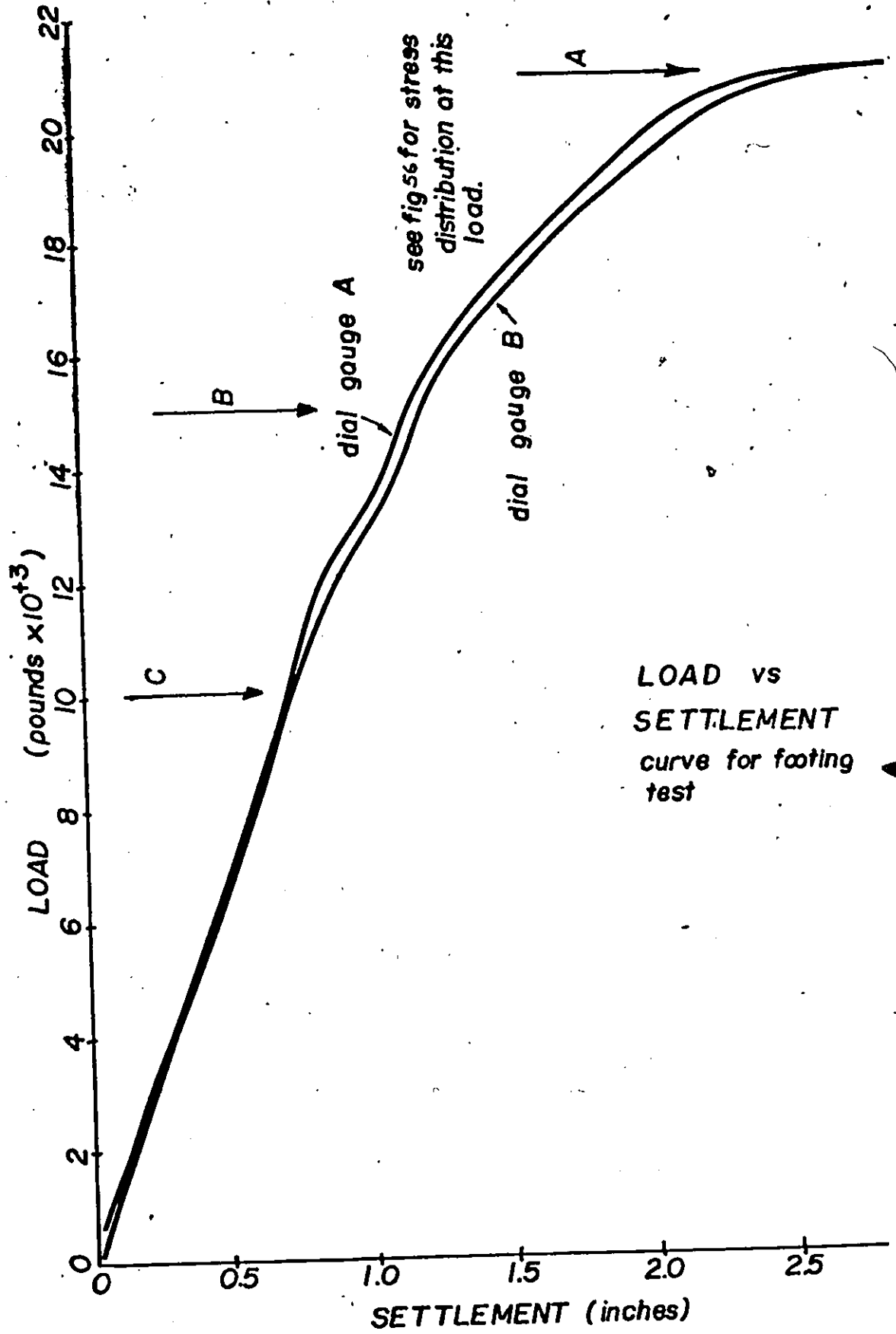
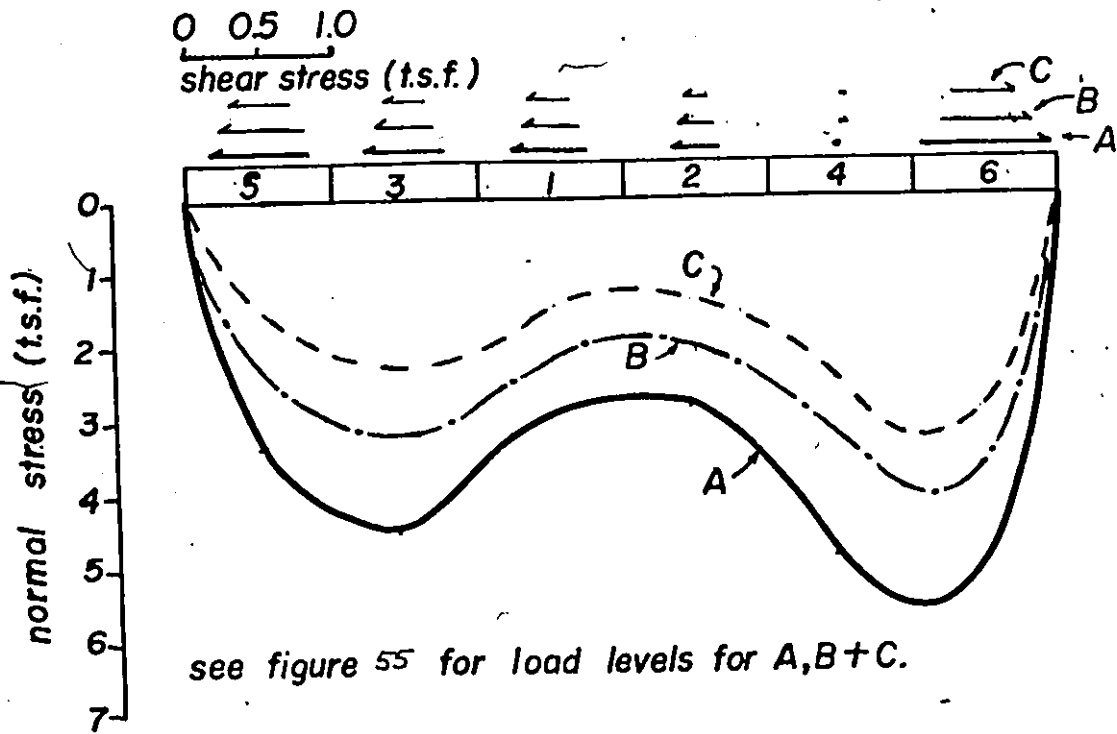

figure 55



STRESS DISTRIBUTION ACROSS FOOTING

figure 56