

Feasibility of Reuse in the Concrete Industry

Zaineb Al-Faesly

Thesis submitted to the
University of Ottawa
In partial fulfillment of the requirements for the degree of
Master of Applied Science in Civil Engineering

Academic Advisor: Dr. Martin Noël



uOttawa

Department of Civil Engineering
Faculty of Engineering
University of Ottawa

Abstract

The construction and demolition (C&D) waste produced by the Canadian construction industry accounts for 27% of the total municipal solid waste disposed in landfills. However, more than 75% of C&D waste has residual value and, consequently, could be salvaged, recycled, and/or reused. The need for comprehensive and integrated waste management mechanisms, technologies, rating systems, and policies is widely recognized. A waste management hierarchy tool exists for reducing and managing waste that follows this order: preventing, minimizing, reusing, recycling, energy recovering, and finally, disposing of the waste. It appears that the highest level attained by the concrete industry in Canada is recycling (e.g., crushing concrete and using it as base aggregate). This study aims to explore the opportunities and barriers to advance to the next level in the waste management hierarchy by reclaiming concrete from decommissioned structures for reuse with minimal reprocessing.

A survey was distributed to members of the Canadian concrete industry to answer two main sets of questions: 1) to what degree, if any, is the Canadian construction industry currently reclaiming waste concrete by recycling and/or reusing it? and 2) what is the perception of industry professionals on concrete reuse? What are the perceived benefits and challenges of such a practice? A total of 125 participants responded to the survey. Although the environmental advantages of concrete reuse were clear to all, views on the financial benefits were mixed. Many participants highlighted that a successful approach to concrete reuse should involve all parties and stakeholders. Overall, there is positive interest in the concept of concrete reuse; however, there is apparent uncertainty on how to approach it and, thus, there is a need for practical guidance to address various technical, logistical, and liability concerns in a comprehensive and holistic manner. Two cases studies – one for a bridge and one for a building – were developed to address some of the technical challenges associated with reusing concrete in structural applications. The case studies were based on local existing structures that were hypothetically disassembled then repurposed in conceptual redesigns. The design of connections to effectively recouple the deconstructed structural components was a focal, and challenging, aspect of the case studies; in support of shifting towards a circular economy, the connection designs were engineered to be reversible to facilitate future adaptation and/or further dismantlement. It is important to highlight

that a desirable reuse project starts in the initial design phase, where the ultimate disassembly and repurposing of the structure is considered from the start (i.e., cradle to cradle design). However, since this is presently not mainstream practice, these case studies focus on the more complex task of deconstructing existing structures that were not designed with the intention of reuse. Although several challenges were encountered, this approach is an essential first step in the present framework to move the discussion forward in the context of reuse of structural concrete members.

Keywords: Concrete reuse, building disassembly, building repurposing, reversible design, cradle-to-cradle design, sustainable design, circular economy, industrial ecosystem, construction & demolition waste, waste management.

Acknowledgements

To Dr. Martin Noël, thank you! You have been my professor, my advisor, my supervisor, my mentor, and my champion! Thank you for wearing many hats and supporting me on this journey – you have been an exemplary thesis advisor and for that, I’m grateful.

My sincere thanks go to Ahmad Shahroodi from EFI Global and Reza Fathifazl from the National Research Council Canada for their invaluable help with my survey. My thanks also extend to the 125 respondents who participated in that survey and provided insights for my research. From the City of Ottawa, Sajjad Haque and Kosta Karadakis, and from the University of Ottawa, Alvaro Perez Martinez, many thanks to you all for providing me with the structural plans necessary for my case studies and being extremely supportive of this research. I would also like to acknowledge the assistance of Dr. Mark Gorgolewski from Ryerson University. Moreover, I’m grateful to the Government of Ontario and the University of Ottawa for granting me the Ontario Graduate Scholarship and the Excellence Scholarship, respectively. Their financial support was key in completing this thesis.

To my engineering community at the University of Ottawa, my gratitude goes to you for making my studies meaningful and enjoyable. I’m very thankful to Dean Jacques Beauvais, Vice-Dean Graduate Studies Liam Peyton, and the Faculty of Engineering for providing me with growth opportunities, financial support, and an inclusive environment to pursue my dreams.

Special thanks go to Professor Hanan Anis, from the Centre for Entrepreneurship and Engineering Design, for being my first mentor as I embarked graduate studies; Rewa Mourad, a dear friend, for her editorial work in polishing my writing; Adnan Sharaf, another dear friend, for providing digital art for this thesis where needed; Mark Patton, from Student Academic Success Services, for his counselling support when the road was difficult; and Dawn Stewart, from Movati Athletic, whose vigorous cycling classes were a retreat from the thesis-writing frenzy.

I would also like to extend many, many thanks to the friends who have been alongside me throughout this journey. Thank you for the smiles, cheers, and constant positive energy – I deeply appreciate you all.

I wish to thank my siblings, Arrwa, Mohammed, Ali, and Qassim for being my source of joy while writing this thesis amid a global pandemic. Enormous thanks go to my parents, Isra'a Al-Ebady and Taofiq Al-Faesly, for their endless love and continuous support. To them, this thesis is dedicated.



أود أن أشكر إخوتي، أروى، ومحمد، وعلي، وقاسم على كونهم مصدر سعادتي أثناء كتابة هذه الأطروحة في ظرف جائحة كورونا. شكراً جزيلاً لوالدي إيسراء العبادي وتوفيق الفيصلي على حبهما اللامتناهي ودعمهما المستمر. هذه الأطروحة مخصصة لهما.

Table of Contents

Abstract.....	ii
Acknowledgements	iv
Table of Contents	vi
List of Figures.....	xi
List of Tables	xvi
List of Symbols	xix
List of Abbreviations	xxiv
1 Chapter 1: Introduction	1
1.1 Research Background.....	1
1.2 Research Objectives	2
1.3 Scope of Research	2
1.4 Novelty and Contribution of the Research.....	3
1.5 Thesis Structure.....	3
2 Chapter 2: Literature Review.....	5
2.1 Introduction	5
2.2 Environmental Impacts of Concrete.....	6
2.2.1 Impact of Production.....	6
2.2.2 Impact of Construction and Demolition Waste.....	9
2.3 Hierarchy of Waste Management.....	10

2.3.1	Reuse versus Recycle.....	11
2.4	Sustainability Efforts.....	13
2.5	Linear and Circular Economies.....	14
2.5.1	Defining a Linear Economy	14
2.5.2	Defining a Circular Economy	15
2.6	Reuse in the Steel Industry.....	16
2.7	Previous Work.....	17
2.7.1	Global Research	17
2.7.2	Existing Guidelines	24
2.8	Challenges	30
2.9	Opportunity in Canada	30
2.10	Research Needs	33
3	Chapter 3: Survey	35
3.1	Background	35
3.2	Objective	35
3.3	Methodology	36
3.4	Results	37
3.4.1	Identification of Polled Participants.....	37
3.4.2	Concrete Professional Stream: Results & Analysis	39
3.4.3	Concrete Structure Owner Stream: Results & Analysis	57
3.4.4	Concrete Supplier Stream: Results & Analysis	62

3.4.5	Concrete Contractor Stream: Results & Analysis.....	65
3.4.6	Additional Comments and Feedback.....	70
3.5	Key Findings.....	71
4	Chapter 4: City of Ottawa Bridge Case Study.....	73
4.1	Background.....	73
4.2	Bridge Description.....	74
4.2.1	Location.....	74
4.2.2	Year Built and Usage.....	75
4.3	Existing Bridge.....	75
4.3.1	View of Existing Bridge.....	75
4.3.2	Disassembly Plan of Existing Bridge.....	76
4.3.3	Inventory of Reusable Bridge Components.....	81
4.4	Repurposed Bridge.....	82
4.4.1	Proposed Geometry.....	82
4.4.2	Load Calculations.....	88
4.4.3	Capacity Calculations.....	98
4.4.4	Reassembly Plan of Repurposed Bridge.....	110
4.5	Discussion.....	113
5	Chapter 5: University of Ottawa Building Case Study.....	115
5.1	Background.....	115
5.2	Building Description.....	116

5.2.1	Location.....	116
5.2.2	Year Built.....	116
5.2.3	Use and Occupancy.....	117
5.3	Existing Building.....	117
5.3.1	View of Existing Building	117
5.3.2	Disassembly Plan of Existing Building.....	126
5.3.3	Inventory of Reusable Building Components	128
5.4	Repurposed Building.....	132
5.4.1	Proposed Geometry	132
5.4.2	Load Calculations.....	136
5.4.3	Capacity Calculations.....	143
5.4.4	Reassembly Plan of Repurposed Building.....	151
5.5	Discussion	159
6	Chapter 6: Conclusions and Recommendations for Future Work	162
6.1	Summary	162
6.2	Conclusions	162
6.3	Recommendations for Further Research and Future Action	165
	Bibliography	168
	Appendix A: Survey Content.....	173
	Introduction	173
	Welcome Remarks.....	173

Reuse in the Concrete Industry	173
Implied Consent Form.....	174
Certificate of Ethics Approval.....	176
Terminology	178
Questions	179
Stream Identifier	179
Questions for the Concrete Professional Stream.....	180
Questions for the Concrete Structure Owners Stream.....	185
Questions for the Concrete Suppliers Stream.....	189
Questions for the Concrete Contractors	192
Additional Comments and Feedback	195
Contact Information	195
Appendix B: Supplementary Bridge Content	197
Bridge Pictures	197
Bridge Calculations	199
quickBridge Full Analysis.....	199
Prestressing Steel Contribution Calculation.....	207
Appendix C: Supplementary Building Content.....	209
Building Pictures.....	209
Building Plans	215

List of Figures

Figure 1.1 Thesis Organization.....	4
Figure 2.1 Cement Production Process.....	7
Figure 2.2 Last Stages of Cement Production (Yang, 2020).....	8
Figure 2.3 Cement Production and Emissions from 2010-2015 (Chatham House Report, 2018)..	8
Figure 2.4 Canadian Construction and Demolition Waste Totalling 11.87 Metric Tonnes (Gorgolewski, 2006).....	9
Figure 2.5 Waste Management Hierarchy (Giroux Environmental Consulting, 2014).....	10
Figure 2.6 Example of Concrete Reuse.....	12
Figure 2.7 Example of Concrete Recycling.....	12
Figure 2.8 Model of Linear Economy (Polytechnique Montréal, 2019).....	15
Figure 2.9 Model of Circular Economy (Polytechnique Montréal, 2019).....	16
Figure 2.10 List of the 14 Awarded Circular Projects (Maerckx, 2019).....	18
Figure 2.11 Analysed Circular Building Projects in Taiwan (van Bueren et al., 2019).....	19
Figure 2.12 Typical Finnish Large-Panel Construction Used from the 1960s to 1975 (Mäkiö, et al., 1994).....	21
Figure 2.13 A Steel-Concrete Composite Beam with High-Strength Friction Grip Bolts (Brambilla, 2019).....	24
Figure 2.14 Core Infrastructure Asset Condition Summary (BluePlan Engineering, 2019).....	31
Figure 3.1 Breakdown of Survey Content.....	35

Figure 3.2 Breakdown of Questions	38
Figure 3.3 Breakdown of Polled Participants	38
Figure 3.4 Distribution of Responses of Projects That Incorporated Reclaimed Concrete	40
Figure 3.5 Breakdown of Reclaimed Concrete	41
Figure 3.6 Willingness of Participants to Using Reclaimed Concrete on a Future Project	44
Figure 3.7 Willingness of Participants to Using Reused Concrete on a Future Project	46
Figure 3.8 Breakdown of Participants' Perception on the Feasibility of Concrete Reuse	49
Figure 3.9 Breakdown of Reasons That Would Lead Professional to Reuse Concrete	52
Figure 3.10 Distribution of Respondents' Estimates of Price Increases When Designing for Disassembly	54
Figure 3.11 Ranking of Obstacles to Concrete Reuse	55
Figure 3.12 Breakdown of Advantages to Concrete Reuse	56
Figure 3.13 Ranking of Suitability of Structural Applications of Concrete Reuse	57
Figure 3.14 Breakdown of Reclaimed Concrete	58
Figure 3.15 Distribution of Respondents' Estimates of Structures Demolished Before Obsolescence	60
Figure 3.16 Ranking of Obstacles to Concrete Reuse	61
Figure 3.17 Perception of Quality and Performance of Reused Structural Concrete Components	62
Figure 3.18 Breakdown of Reclaimed Concrete	63
Figure 3.19 Ranking of Obstacles to Concrete Reuse	64

Figure 3.20 Distribution of Respondents’ Concrete Reclamation Efforts	66
Figure 3.21 Breakdown of Concrete Recovered.....	66
Figure 3.22 Customers of Contracting Companies.....	68
Figure 3.23 Dismantling Versus Demolition Cost.....	68
Figure 4.1 Tenth Line Road Overpass (Google Maps).....	74
Figure 4.2 Distant Underside View of Overpass Showing Full Width (Google Maps)	75
Figure 4.3 Plan View of Bridge	77
Figure 4.4 Elevation View of Bridge	78
Figure 4.5 Cross-Sectional View of Bridge	79
Figure 4.6 (a) Cut option 1 (b) Cut option 2 and (c) Cut option 3	80
Figure 4.7 Cross-Sectional View of the Proposed Bridge	84
Figure 4.8 Plan View of the Proposed Bridge	85
Figure 4.9 CL-625-ONT Truck Live Loading (CSA S6:19)	88
Figure 4.10 CL-625-ONT Lane Load (CSA S6:19)	89
Figure 4.11 CPCI 1600 Girder Dimension from Bridge Plans	100
Figure 4.12 Tendon Profile	103
Figure 4.13 Proposed Girder-Slab Connection	111
Figure 5.1 The Faculty of Social Sciences Seen from the Outside (University of Ottawa, 2021)	116
Figure 5.2 Closer View of the FSS Building (Canadian Architect, 2014)	117

Figure 5.3 West Building Elevation.....	118
Figure 5.4 North Building Elevation	119
Figure 5.5 East Building Elevation.....	120
Figure 5.6 South Building Elevation	121
Figure 5.7 Ground Floor Framing Plan.....	122
Figure 5.8 Eighth Floor Framing Plan	123
Figure 5.9 Ninth Floor Framing Plan.....	124
Figure 5.10 Twelfth Floor Framing Plan	125
Figure 5.11 Strip of Slab ‘Pieces’ Retained from the Second Floor Framing Plan	126
Figure 5.12 Typical Concrete Column Transition	127
Figure 5.13 Typical Tie Arrangements for Concrete Columns in the FSS Building.....	128
Figure 5.14 FSS Building from the Inside Showing the Floor Openings.....	131
Figure 5.15 First Floor Plan of the Proposed Building.....	133
Figure 5.16 Second Floor Plan of the Proposed Building	134
Figure 5.17 Elevation View of the Proposed Building.....	135
Figure 5.18 Yield Line Pattern for Option 1	140
Figure 5.19 Yield Line Pattern for Option 2.....	142
Figure 5.20 Table 7.13.7 Circular Tied or Spiral Columns	145
Figure 5.21 Column-Foundation Connection Options.....	152
Figure 5.22 Proposed Column-Foundation Connection	153

Figure 5.23 Column-Foundation Connection Design Configuration	155
Figure 5.24 Column-Slab Connection Options.....	156
Figure 5.25 Proposed Column-Slab Connection	157
Figure 5.26 Slab-Slab Connection Options	159
Figure 5.27 Proposed Slab-Slab Connection	159

List of Tables

Table 2.1 Analysis of Relevant Specifications	26
Table 3.1 Location of Polled Participants	36
Table 3.2 Breakdown of Usage of Reclaimed Concrete	41
Table 3.3 Sources of Reclaimed Concrete Specified	42
Table 3.4 Analysis of Commentary on Consideration of Using Reclaimed Concrete	45
Table 3.5 Analysis of Commentary on Consideration of Using Reused Concrete on a Future Project	47
Table 3.6 Analysis of Commentary on Feasibility of Using Reused Structural Concrete for New Construction	50
Table 3.7 Outline of Other Reasons to Support Reuse of Concrete	53
Table 3.8 Summary of Other Obstacles to Reuse of Concrete	55
Table 3.9 Breakdown of Advantages of Including Reused Concrete for the Concrete Structure Owner Stream	61
Table 3.10 Breakdown of Advantages of Including Reused Concrete for the Supplier Stream ..	65
Table 3.11 Purposes or Applications of Reused Concrete	67
Table 3.12 Challenges Association of Disassembly of Concrete Structures	69
Table 3.13 Breakdown of Advantages of Including Reused Concrete for the Contractor Stream	70
Table 4.1 Summary of Advantages and Disadvantages Associated with Each Option	80
Table 4.2 Superstructure Elements of Bridge	83

Table 4.3 Component Changes After Redesign	87
Table 4.4 Component Percentage Reused	87
Table 4.5 Governing Values for Moment and Shear	90
Table 4.6 Governing Shear and Moment Envelopes from the CL-625-ONT Truck for All Spans With quickBridge	91
Table 4.7 Conditions Check for the Use of the Beam Analogy Method	92
Table 4.8 Live Moment and Shear Per Girder Results	96
Table 4.9 Dead Load Per Girder Results	97
Table 4.10 Concrete Material Properties	99
Table 4.11 Girder Section Properties	100
Table 4.12 Prestressing Tendons Properties	101
Table 4.13 Compression Steel Properties	102
Table 4.14 Material Resistance Factors	102
Table 4.15 Prestressing Steel Shear Contribution in Girder B	103
Table 5.1 Column Inventory	129
Table 5.2 Column Inventory Quick Summary	131
Table 5.3 Slab Inventory	131
Table 5.4 Component Percentage Reused	136
Table 5.5 Design Live Loads	137
Table 5.6 Design Dead Loads	137

Table 5.7 Gravity Load on Ground Floor Interior Columns.....	137
Table 5.8 Gravity Load on Ground Floor Edge Columns	138
Table 5.9 Gravity Load on Ground Floor Corner Columns.....	138
Table 5.10 Factored Loads using Ultimate Limit State Load Combinations	138
Table 5.11 Column Eccentricities.....	139
Table 5.12 Column Bending Moments.....	140
Table 5.13 Summary of Factored Axial Load and Resultant Moment.....	145
Table 5.14 Moment Capacity Check for all Column Location.....	146
Table 5.15 Column-Foundation Connection Design Forces.....	153
Table 5.16 Column-Slab Connection Design Forces.....	157

List of Symbols

Symbol Description

English Symbols

a	Depth of equivalent rectangular stress block
A	Cross-sectional area of material with area parallel to the applied force vector
A	Area of element
A_g	Gross area of section
A_p	Area of prestressing tendons
A_{ps}	Prestressing tendons area
A'_s	Compression reinforcement area
A_s	Area of longitudinal reinforcement on the flexural tension side of the member
A_{st}	Area of reinforcement in tension tie
A_t	Area of one leg of closed transverse torsion reinforcement
A_v	Area of transverse shear reinforcement perpendicular to the axis of a member within a distance s
A_{Trib}	Tributary area
b	Width of member
b_o	Perimeter of critical section for shear in slabs
b_w	Minimum effective web width
B	Bridge width
C_c	Compression force in concrete
d	Effective depth

d'	Distance from extreme compression fibre to centroid of the top reinforcement
d_b	Diameter of bar, wire, or prestressing strand
d_c	Distance from extreme tension fibre to centre of the longitudinal bar or wire located closest to it
d_p	Distance from extreme compression fibre to centroid of the prestressing tendons
d_v	Effective shear depth, taken as the greater of $0.9d$ or $0.72h$
D_T	Truck load distribution width
E_c	Modulus of elasticity of concrete
E_p	Modulus of elasticity of tendons
E_s	Modulus of elasticity of reinforcing bars
f'_c	Specified compressive strength of concrete
f_{cr}	Cracking strength of concrete
f_{po}	Stress in prestressed reinforcement when stress in the surrounding concrete is zero
f_{pr}	Stress in prestressing tendons at factored resistance
f_{pu}	Specified tensile strength of prestressing steel
f_{py}	Yield strength of prestressing steel
f_y	Specified yield strength of non-prestressed reinforcement or anchor steel
F	Force applied
F_{pe}	Effective stress in prestressing tendons after allowance for all prestress losses
F_s	Skew factor
F_T	Truck load fraction
F_y	Specified yield strength of structural steel section
h	Girder height

h	Wall thickness or the minimum column dimension
h_f	Flange height
k_p	Factor dependent on the type of prestressing steel
l	Length of member
l	Length of the yield line
l_{db}	Basic development length
L_e	The equivalent span length specified for the uses of the beam analogy method
m_b	Bending moment per unit length of yield line
M_D	Longitudinal moment due to the dead load
M_f	Moment due to factored loads
M_r	Factored flexural resistance of a section in bending
M_L	Longitudinal moment per girder due to the CL-W loading for girder-type bridges
M_T	Longitudinal moment generated by one lane of CL-W loading
n	Number of design lanes on a bridge
N	Number of longitudinal girders in the bridge deck width B
N_f	Factored axial load normal to the cross-section occurring simultaneously with V_f , including the effects of tension due to creep and shrinkage
$P_{r,max}$	Maximum axial load resistance calculated
P_{r0}	Factored axial load resistance at zero eccentricity
R_L	Modification factor for multi-lane loading
s	Spacing of stirrups measured parallel to the longitudinal axis of a component
s_{ze}	Equivalent value of s_z that accounts for influence of aggregate size
S	Centre-to-centre spacing of longitudinal girders of a deck-on-girder bridge

S_c	Transverse distance from the free edge of the cantilever overhang slab to the centreline of the web of the exterior girder
T_p	Tension force in prestressed tendons
v_c	Factored shear stress resistance provided by the concrete
v_f	Factored shear stress
V_c	Shear resistance attributed to the concrete factored by ϕ_c
V_f	Factored shear force
V_p	Factored shear resistance provided by prestressed tendons
V_r	Factored shear resistance
V_s	Factored shear resistance provided by shear reinforcement
V_D	Longitudinal shear due to the dead load
V_L	Longitudinal shear per girder due to the CL-W loading for girder-type bridges
V_T	Longitudinal shear generated by one lane of CL-W loading
w	Uniformly distributed load on an element of area
w_f	Factored load per unit area of slab
W	Total load of a plate segment
W_c	Deck width
W_e	Width of a design lane

Greek Symbols

α	Vector sum of angular changes in elevation and plan of a prestressing tendon profile from the jacking end to any point x
α_1	Ratio of average stress in rectangular compression block to the specified concrete strength
α_s	Factor that adjusts v_c for support dimensions

β	Factor accounting for shear resistance of cracked concrete
β_1	Ratio of depth of rectangular compression block to depth to the neutral axis
γ	Density of concrete
γ_c	Truck load modification factor for slab-on-girder bridges
δ	Deflection of element
ε_x	Longitudinal strain
θ	Angle of inclination of the principal diagonal compressive stresses to the longitudinal axis of a member
θ	Angle change at the yield line corresponding to the virtual displacement δ
λ	Lane width parameter
μ	Lane width modification factor
ρ	Ratio of non-prestressed tension reinforcement
σ	Normal stress
τ	Shear stress
ϕ_a	Resistance factor for structural steel
ϕ_c	Resistance factor for concrete
ϕ_p	Resistance factor for reinforcing tendons
ϕ_s	Resistance factor for non-prestressed reinforcing bars

List of Abbreviations

Abbreviation Description

<i>CCPIS</i>	Canadian Core Public Infrastructure Survey
<i>CHBDC</i>	Canadian Highway Bridge Design Code
<i>CIRC</i>	Canadian Infrastructure Report Card
<i>C&D</i>	Construction and Demolition
<i>MTO</i>	Ministry of Transportation
<i>NBC</i>	National Building Code of Canada
<i>NBL</i>	North bound lane
<i>OBC</i>	Ontario Building Coode
<i>OHBDC</i>	Ontario Highway Bridge Design Code
<i>OPS</i>	Ontario Provincial Standards for Roads and Public Works
<i>OPSD</i>	Ontario Provincial Standard Drawings
<i>OPSS</i>	Ontario Provincial Standard Specifications
<i>SBL</i>	South bound lane
<i>UHPC</i>	Ultrahigh-Performance Concrete
<i>ULS</i>	Ultimate Limit State
<i>UO</i>	University of Ottawa

1 Chapter 1: Introduction

1.1 Research Background

The construction and demolition waste produced by the Canadian construction industry is responsible for 27% of the total municipal solid waste sent to landfills (Yeheyis et al., 2013). However, it is apparent that over 75% of what the construction industry proclaims as waste has a residual value, and therefore could be salvaged, recycled, and/or reused (Yeheyis et al., 2013). Around 70% of the environmental impacts of the average new construction product arise from the energy needed to produce it. Concrete production, in particular, has a significant carbon footprint, with cement manufacturing accounting for 5-10% of global greenhouse gas emissions (Huntzinger & Eatmon, 2009). Reusing a product saves that energy which justifies the outcome of waste-reuse being placed above recycling in the waste management hierarchy. Reuse of materials from decommissioned structures diverts waste from landfills, increases resource recovery, reduces environmental impacts of disposal, and saves energy which results in a reduction of emissions, in particular carbon emissions (Kay & Essex, 2009).

Currently, concrete is occasionally being recycled (in fact, down-cycled since the crushed concrete is generally used for road base material rather than for new structural applications); recycling also reduces waste to landfill and consumption of raw materials but at a higher environmental cost, creating more carbon emissions than reuse. Furthermore, the down-cycled concrete material does not substantially reduce the cement demand and embodied energy of new concrete structures. As such, there is a need to explore the feasibility of advancing the concrete industry to a higher level in the waste management hierarchy by reusing structural concrete components extracted from decommissioned structures that, in many cases, are still in relatively good condition. However, there is very limited research on concrete reuse practices in Canada; there are no clear policies or incentives driving this change and the perception of industry practitioners related to this practice is currently unknown. From an engineering perspective, there is a lack of technical support in the forms of guidelines, codes, and standards available to those considering the reuse of concrete in their design practices, and only limited guidance on protocols for assessing the quality and integrity of existing structural members. Additional challenges include solutions for dismantling and

reassembly, the logistics of supply and demand for reused components, liability concerns, and the development of life cycle assessment models to understand the overall impact of reuse compared to conventional practice. Addressing these challenges requires a holistic and multidisciplinary approach, much of which is outside the scope of this thesis; nevertheless, this study presents a necessary first step in this direction.

1.2 Research Objectives

The primary aim of this study is to explore the feasibility of reuse in the concrete industry. In order to achieve this goal, specific objectives are summarized as follows:

1. To complete a comprehensive literature review on reuse in the concrete industry to assess the current state of the art.
2. To conduct a survey that is geared towards concrete industry professionals to:
 - a. Understand if the construction and demolition industry is doing any reclamation work, and, more specifically, how much concrete is being recycled or reused; and,
 - b. Examine what the perception of professionals is regarding concrete reuse and note what advantages and disadvantages they associate with this practice.
3. To develop two case studies using existing concrete structures in a hypothetical reuse scenario requiring disassembly and reconstruction to demonstrate, at a conceptual level, how the practice of concrete reuse could be achieved and to identify additional opportunities and challenges. The cases studies will be based on:
 - a. A bridge in the City of Ottawa, and
 - b. A building at the University of Ottawa.

1.3 Scope of Research

The research study presented herein focuses on reuse strictly in the concrete industry. While brief discussions on reuse in the steel industry are offered, they are primarily intended to contrast the progress made in the steel sector with that of the concrete sector. For the survey on concrete reuse, it was concentrated on the Canadian construction and demolition industry; therefore, it was mainly advertised for those working in the Canadian context. This survey was divided into four streams:

the Concrete Professional (e.g., design engineer, consultant, and/or quality control); the Concrete Structure Owner (e.g., municipality, provincial or federal agency, and/or private owner); the Concrete Supplier (e.g., precast, ready-mix), and the Concrete Contractor (e.g., builders, demolishers). With regards to the case studies, for the bridge, only the superstructure elements were considered as part of the disassembly and redesign process, whereas for the building, it was the primary gravity load resisting system. Note that the main aim of the case studies is to uncover the possibilities and constraints relating to technical design elements and are therefore developed to a conceptual level only. The deconstruction plans and structural designs are hypothetical and are not meant to account for all possible construction details or loading situations, which are outside the scope of this thesis. Other issues such as economic considerations, logistics, life cycle evaluations, and liability concerns are also not studied; however, these topics should be pursued in the future. Instead, these case studies are meant to be a first step in exploring the feasibility of structural concrete reuse from an engineering standpoint and to stimulate further discussion in this regard.

1.4 Novelty and Contribution of the Research

While previous surveys have queried members of the steel industry regarding the concept of reuse, to the author's knowledge this has never before been done in the context of concrete structures. The initial part of this research aims to address this gap by conducting a survey geared towards professionals in companies and organizations involved in the concrete industry. This part of the study intends to uncover the amount of reclamation, specifically relating to reuse, being done for concrete while also understanding the benefits and impediments to such a practice. Most of the existing literature provided insights on reuse of non-structural components for non-structural applications or advised on how to design future concrete structures for disassembly and adaptability. The case studies presented herein serve as the first examples exploring the reuse concept for structural concrete components from existing structures not intentionally designed for disassembly and constructed monolithically which is representative of current practice.

1.5 Thesis Structure

This thesis contains six chapters as shown in Figure 1.1, and is divided as follows:

Chapter 1 – Introduction: introduces the significance of this thesis, presents the research objectives, and defines the scope.

Chapter 2 – Literature Review: provides background information regarding the thesis topic, summarizes previous research on the reuse of concrete, and the outlines the existing guidelines.

Chapter 3 – Survey: shares results of a survey sent to professionals working with and in the concrete industry to understand their perception of concrete reuse and gauge their reclamation efforts – if any.

Chapter 4 – City of Ottawa Bridge Case Study: presents a hypothetical repurposed bridge design based on an existing bridge to demonstrate the concept of concrete reuse.

Chapter 5 – University of Ottawa Building Case Study: presents a hypothetical repurposed building design based on an existing building to demonstrate the concept of concrete reuse.

Chapter 6 – Conclusions and Recommendations for Future Work: summarizes the conclusions from this thesis and proposes recommendations for further research.

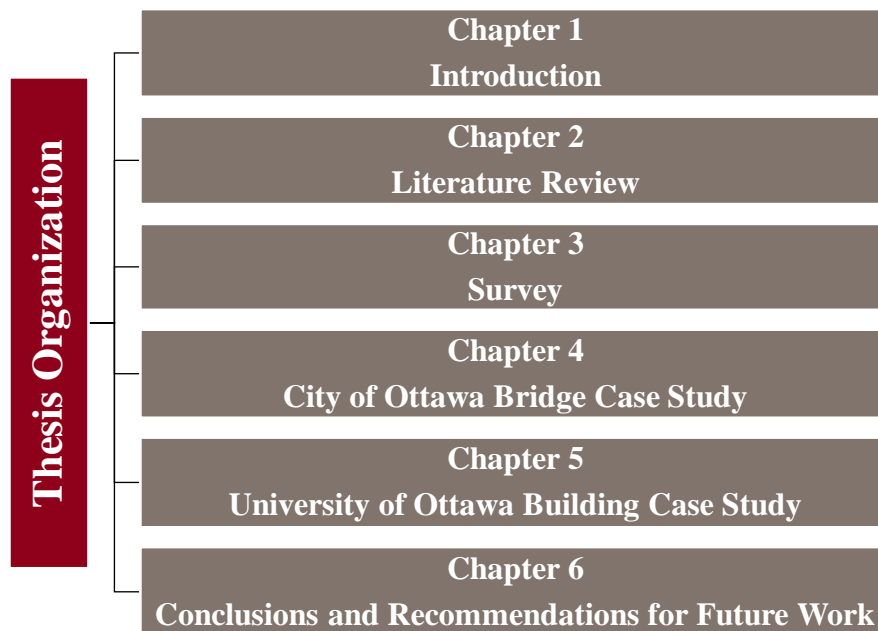

Figure 1.1 Thesis Organization

2 Chapter 2: Literature Review

2.1 Introduction

Every man-made structure eventually and inevitably reaches the end of its useful life. This can occasionally result from wear-and-tear that causes gradual functional obsolescence of structural components leading to poor performance of structures. However, structures are also frequently decommissioned for other reasons which may include the need for functional improvements or changes in land use, a trend which will likely accelerate in the future with the emergence of autonomous vehicles, smart cities, and more remote workforces. Therefore, the construction industry faces an increased need for ensuring the future adaptability of its buildings and infrastructure. This can be done by adopting strategies during the initial design phase that will more easily facilitate future deconstruction of the building elements, which allows for maximum recovery of material resources for a second useful life (Antonini et al., 2010). This novel approach is often known as cradle-to-cradle design, where waste from one project becomes a resource for the next – as opposed to the traditional cradle-to-grave design, where decommissioned structures are viewed as waste to be discarded. Consequently, an industrial ecosystem is needed in which construction materials flow in continuous cycles.

Concrete is the most widely used building material worldwide yet is among the least practical for deconstruction and reuse. There are several barriers to concrete reuse that can be put under three main categories: technical, logistical, and legislative (Nordby, 2019). Technical challenges include the lack of guidelines, codes, and/or standards to facilitate reuse. This lack of support leads to uncertainties on how to implement the concept and as such, many do not. Logistically, there is an undeveloped market for concrete reuse because it lacks the economic driving forces to promote widespread adoption. This leads to third barrier: legislative. Policies in place today are not driving reuse; in Canada, no policies exist to push the construction and demolition industry to prioritize reuse in their work. It is important to state that those three categories of barriers are interlinked and must be solved in parallel to propel the reuse industry forward.

Most of the infrastructure that exists in the built environment today was implicitly designed to be demolished at its end of life; as such, considerations for demountable construction are rarely taken into account. This prevents the industry from pushing forward with reuse. Therefore, there needs to be a paradigm shift in the standard construction practices to move towards reversible and adaptable design that facilitates change and disassembly. This approach helps extend the life and use of structures, since changes can be incorporated during the life cycle of structures without having to resort to complete demolitions or grand transformations (Maerckx et al., 2019). Moreover, these existing components can easily be disassembled and reused in other construction with minimal need to break components apart mechanically and destructively.

It is critical that awareness is raised about the positive impacts of reuse. This can be done by creating a roadmap for a shift to a circular economy by involving large public corporations and private sector establishments in workshops and/or dialogue meetings (Nordby, 2019). This process must also be incentivized economically with the potential introduction of new tax structures and financial aid from the public innovation government division. Furthermore, the development of pilot projects and written guidelines are needed to provide examples of what this process can look like in the real world.

2.2 Environmental Impacts of Concrete

2.2.1 Impact of Production

Concrete is a fundamental building block of built structures; in fact, it is the most-used construction material worldwide. It is a water demanding material, consuming close to a tenth of the world's industrial water use. It is anticipated that in 2050, 75% of the water demand for concrete production will likely occur in areas that are expected to experience water insecurity (Miller et al., 2018). As such, the current level of concrete production is not sustainable. In addition to the high consumption of water, there is also the high generation of CO₂ emissions associated with concrete production. Every cubic meter of concrete produced is linked to approximately 0.2 tons of CO₂ emissions (Gartner, 2004).

Cement, a critical ingredient of the creation of concrete, is not a natural occurring organic material. It is manufactured through the mixture of eight main chemical ingredients during the cement production process. Those ingredients are lime (calcium oxide or calcium hydroxide) at 60-65%, silica (silicon dioxide) at 17-25%, alumina (aluminium oxide) at 3-8%, magnesia (magnesium oxide) at 1-3%, iron oxide at 0.5-6%, calcium sulphate at 0.1-0.5%, sulfur trioxide at 1-3%, and alkalis at 0-1% (Howden, 2020). The extensive cement production process can be summarized in six key steps illustrated in Figure 2.1.

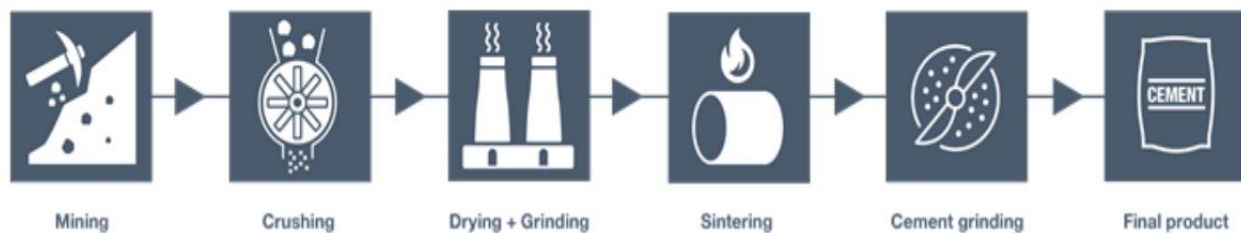

Figure 2.1 Cement Production Process

The process begins by mining for raw materials, primarily limestone and clay, often extracted by blasting or drilling using heavy mining machinery. This raw material is then transported to crushers to reduce its particle size. In the third step, the raw mix as well as the additives needed are sent to the raw mill for drying – first chamber – and grinding – second chamber. This results in fine raw meal materials that are then sintered. Through the extreme heat in sintering that is produced from the burning of fuel where coal, natural gas, fuel oil, and petroleum coke are often used for firing, a new extremely hot substance called clinker comes out. The clinker is then cooled from 1350-1450 Celsius to approximately 120 Celsius through the use of various cooling methods. Lastly, at the cement mills the clinker is mixed with other additives required for the production of specific types of cement. The mill then grinds it into fine powder creating the final product: cement (Howden, 2020). These last stages of cement production are illustrated in Figure 2.2 where it can be seen that this process releases considerable amounts of carbon dioxide into the atmosphere.

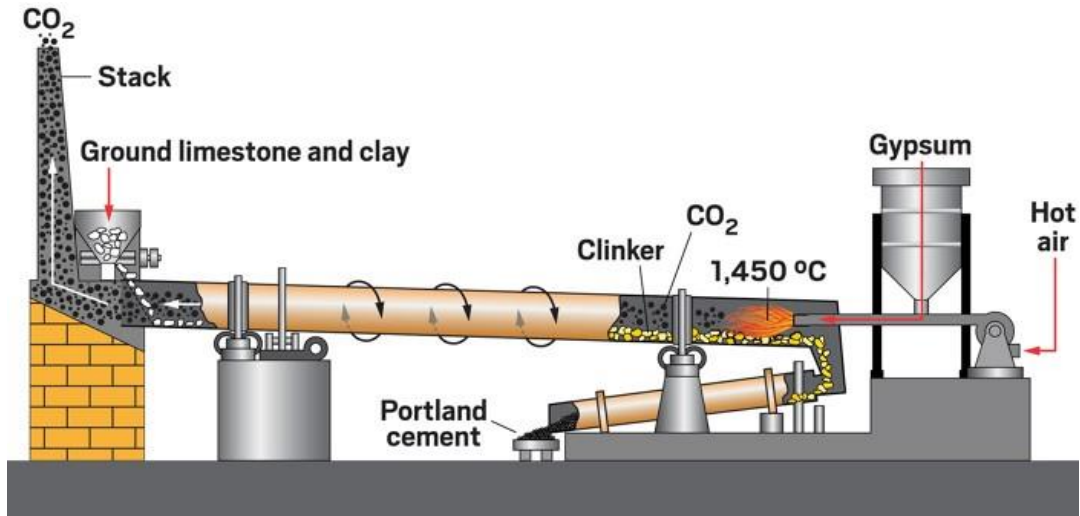

Figure 2.2 Last Stages of Cement Production (Yang, 2020)

The process of producing cement is extremely taxing to the environment. This is mainly due to the clinker manufacturing process that produces a lot of carbon emissions due to the chemical and thermal combustion process. Each year, more than 4 billion tons of cement are produced, accounting for approximately 8% of all carbon emissions worldwide, contributing substantially to climate change (Chatham House Report, 2018). Worse yet, it is estimated that the global cement production is set to rise to over 5 billion tons per year over the coming three decades. Figure 2.3 shows the cement production and its emissions from 2010-2015 around the world.

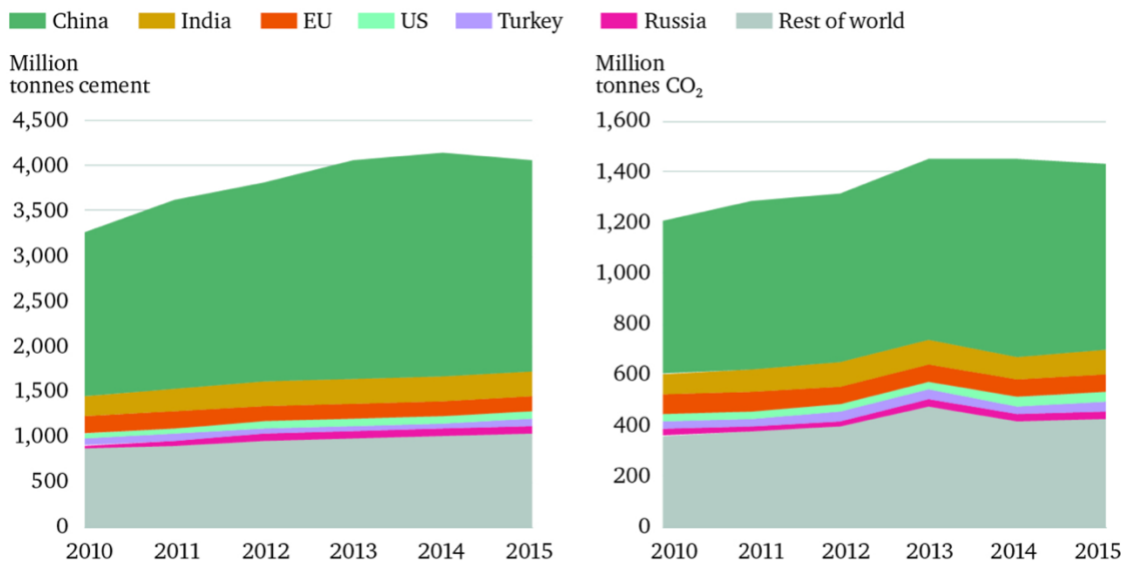

Figure 2.3 Cement Production and Emissions from 2010-2015 (Chatham House Report, 2018)

2.2.2 Impact of Construction and Demolition Waste

Construction and demolition waste has contributed to increasingly serious problems in environmental, social, and economic contexts. Figure 2.4 shows the Canadian construction and demolition waste with concrete in second place at 21%. There is no established framework for utilization of these waste materials which are disposed both legally and illegally. This harms the environment, contributes to the increase of energy consumption, and slowly exhausts finite landfill resources (Marzouk & Azab, 2014). The research findings show that recycling construction and demolition waste leads to significant reductions in emissions, energy use, global warming potential, and conserves landfill space when compared to disposal of wastes in landfills. Furthermore, the cost of mitigating the impact of disposal is extremely high. Therefore, it is necessary to recycle construction and demolition waste (Marzouk & Azab, 2014).

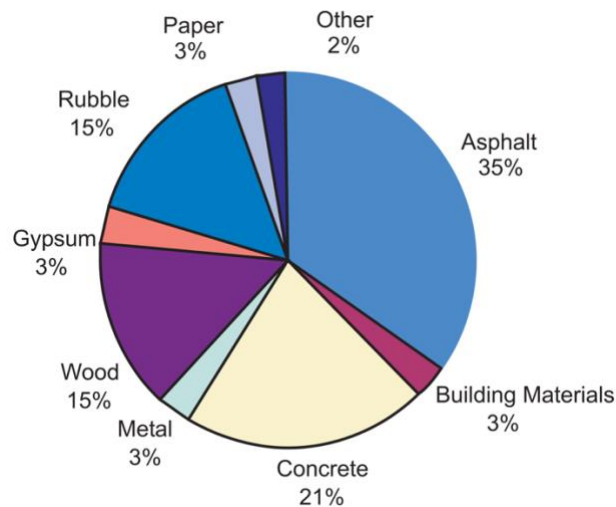

Figure 2.4 Canadian Construction and Demolition Waste Totalling 11.87 Metric Tonnes (Gorgolewski, 2006)

To meet the need of concrete demand globally, over 10 billion tons of sand and natural rocks are sourced to produce it. This is contrasted by the over 11 billion tons of waste that is made from demolition and construction (Mehta, 2002). Note that approximately 50% of the quantities stated above are considered concrete wastes (Tam, 2008). These significant quantities of demolished concrete, and several other solid wastes, play a part not only to environmental deterioration but also to solid waste contamination (Addis, 2012). The act of destruction has been determined to consume up to 25% of the building's total construction and operational energy, especially for

buildings with a limited lifespan (Crowther, 1999). The present paradigm of the life cycle of construction materials and components, characterised by Crowther as "cradle-to-grave," leads to concrete elements ending up as unusable waste. Crowther demonstrated that if the alternative cyclic model "cradle-to-cradle" is used on concrete elements, it will not only save energy used in materials manufacturing, but it will also save CO₂ emissions, solid waste, and air pollution caused by demolition operations.

2.3 Hierarchy of Waste Management

The waste management hierarchy is a guideline to prioritize the methods of using resources to lower negative environmental impacts. The hierarchy provides the priorities of dealing with waste and presents the following actions in order of significance (Cooper, 1994):

1. Reduce the material quantity and waste generation
2. Reuse existing components
3. Recycle materials by adapting waste into reusable secondary materials
4. Generate energy from the waste if permitted
5. Dispose of waste in the most environmentally favourable option

In Figure 2.5, a schematic of the waste management hierarchy is presented.

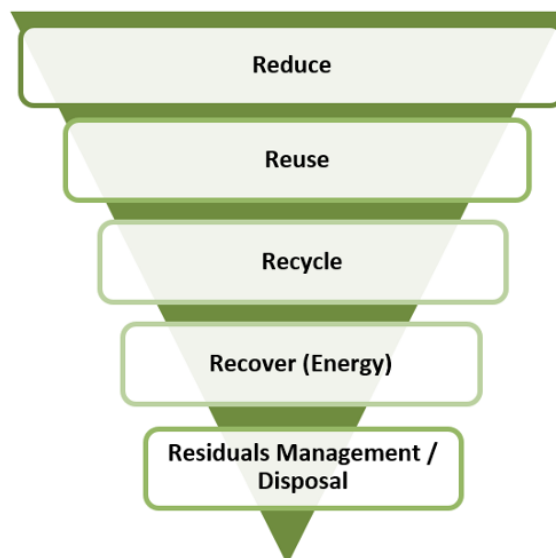

Figure 2.5 Waste Management Hierarchy (Giroux Environmental Consulting, 2014)

When dealing with material and waste, the first priority is reduction. This can be done by using, where possible, a different material that is more environmentally sustainable like wood, designing more efficiently to use less concrete, and/or implementing more rigorous methodology to waste less concrete on- and off-site. If this is not possible, one proceeds to step 2 where the guideline encourages reuse. This can be done by taking existing components from previous decommissioned structures to reuse in new structures; for example, reusing columns from an old office building in the design of a new residential building. Following reuse, the recycling of material is tried. This can be done by crushing old concrete components into coarse aggregates to use, for example, as base for roads, parking lots, and/or driveways. In this hierarchy, disposal is considered only as a last resort when no other options are available.

While recycling concrete is a helpful measure, as discussed in Section 2.2.2, since it diverts waste from being sent to landfills, it is imperative to highlight that with the action of recycling, component disassembly, material separation, transportation, storage, and processing are involved, all of which produce additional costs and environmental impacts. This makes material reuse preferable over recycling (Gorgolewski et al., 2006). As it stands, the highest level the concrete industry reaches in Canada on a semi-regular basis is recycling (e.g., crushing concrete and using it as base aggregate). Contrarily, the reuse of steel is not a novel practice in the steel industry and is primarily limited by economic factors. By conducting this research, the aim is to identify opportunities and challenges in order to advance to the next level in the waste management hierarchy by salvaging concrete members from decommissioned structures and subsequently reusing them in new construction.

2.3.1 Reuse versus Recycle

In the literature, the terms reuse and recycle are sometimes used interchangeably as synonyms of each other. However, as outlined in subsection 2.3, the two are inherently different with one – reuse – trumping the other – recycle – with regards to its environmental benefits. In this thesis, reclaimed materials are those that have been diverted from the waste stream and not disposed in landfills (i.e., either reused or recycled). These can be further classified as follows:

Reused materials are any materials taken from the waste stream and reused in their original form, with minimal reprocessing. They may be cut to size, adapted, cleaned up, or refinished, but they are fundamentally retaining their original form.

- *An example of reuse: A retaining wall built with concrete blocks is carefully disassembled and the old components are cleaned and stacked on pallets ready for reuse as reclaimed material to create a new concrete wall. Reference Figure 2.6 below.*

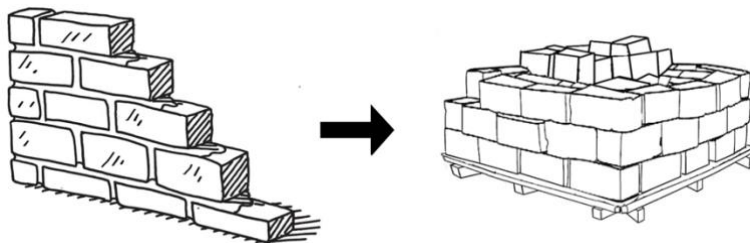

Figure 2.6 Example of Concrete Reuse

Recycled materials are any materials taken from the waste stream and reprocessed and remanufactured (i.e., downcycled) to form part of a new product (e.g., aggregates).

- *An example of recycling: An old concrete block wall is knocked down to ground level using a machine, with the broken concrete pieces then being crushed and screened in a mechanical crusher to create an aggregate substitute. Reference Figure 2.7 below.*

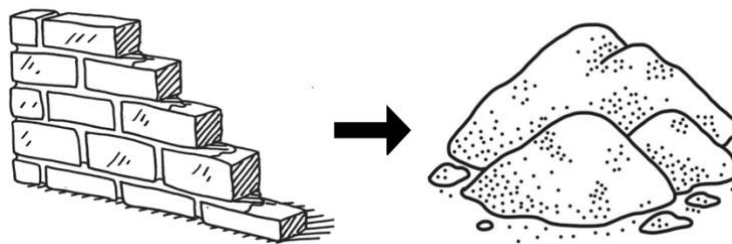

Figure 2.7 Example of Concrete Recycling

Reusing materials in their original form has the following benefits:

- Reduces the need for new virgin materials

- Reduces the energy demand for manufacturing new products
- Retains the embodied energy of the material (the energy required to extract, process, manufacture and deliver it)

This cuts carbon emissions, offers significant environmental savings, and can save a significant amount of money (BioRegional Development Group, 2007). While some of these benefits can also be obtained through the recycling of materials, more energy is generally required to reprocess and remanufacture those recycled materials. Moreover, the recycling of concrete a) produces a material that is often viewed as lower quality and mainly used for low value applications, and b) when it is used as a replacement for natural aggregate in concrete, it still requires new cement to be produced to bind them together, this being the main contributor to CO₂ emissions and energy use. Therefore, it is a worthwhile goal to develop a pathway towards a future industrial ecosystem where all waste is treated as a resource. The material – in this case concrete - reaching the end of its lifetime in one generation of structures will be viewed holistically as a resource to be used for future applications.

2.4 Sustainability Efforts

Society is becoming increasingly conscious of the negative environmental impacts associated with concrete and as such, the construction industry has been introducing various measures to quell some of these adverse drawbacks discussed in previous sections. One solution involves absorbing carbon dioxide during the manufacturing process. The manufacturing of one kilogram of cement typically leads to the emission of 1.5 kilograms of carbon dioxide into the environment. Carbon capture and sequestration, on the other hand, can keep CO₂ from entering the atmosphere. Another measure is changing the chemistry of cement by using a synthetic version of mineral wollastonite instead of lime. Since cement production is the main issue in concrete's carbon footprint, using less cement in concrete will automatically improve its environmental effect. By changing the quantities of the other component materials such as pulverised fly ash, silica fume, and ground granulated blast-furnace slag to become partial replacements of cement, it becomes more sustainable. Another approach is to use renewable energy sources such as biomass during production instead of coal or gas (Master Builders Solutions, 2019).

Despite these advances, it is important to highlight that around 70% of the environmental impacts of the average new construction product arise from the energy needed to produce it (Huntzinger & Eatmon, 2009). Therefore, while optimizing the production process has the potential to subdue the current 8% of anthropogenic carbon dioxide associated with cement production, it is only tackling the future production of concrete but not addressing what to do with the concrete that exists today in the built environment, whose fate is generally demolition.

2.5 Linear and Circular Economies

The shift towards an industrial ecosystem with regards to the construction industry requires a change to the economic model. The current linear economic model and the preferred circular economic model are discussed below.

2.5.1 Defining a Linear Economy

For a long time, the world's economy has remained "linear." This means that raw resources are used to create a product, and any waste (such as packaging) is discarded once it is used. In a recycling-based economy, trash is transformed back into useable material. Waste glass, for example, is recycled to produce new glass, and wastepaper is recycled to generate new paper. The economy must become circular in order to assure that there will be adequate raw materials for food, shelter, heating, and other requirements in the future. This entails reducing waste by improving the efficiency of products and materials and repurposing them. If additional raw materials are required, they must be procured in a sustainable manner to avoid harming the natural and human environment (Government of the Netherlands, 2020). Figure 2.8 illustrates what a linear economy looks like in the construction sector. It starts at the left and shows how virgin material is extracted from natural sites (yellow), then it moves to transforming this raw material into usable components in factories (blue), followed by the consumption of material in construction sites to build infrastructure (red), and lastly, it ends in the disposal of material at the end of its intended use (green).

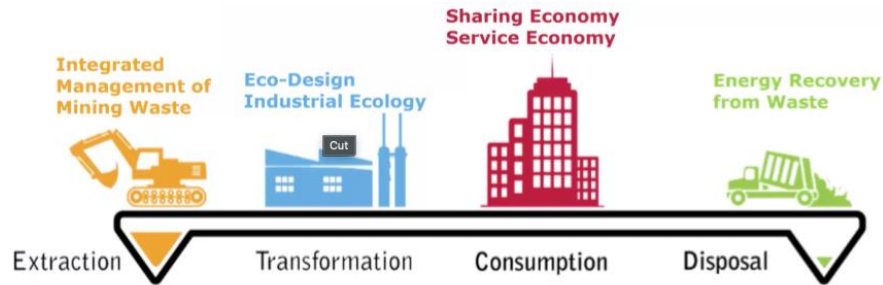

Figure 2.8 Model of Linear Economy (Polytechnique Montréal, 2019)

2.5.2 Defining a Circular Economy

Manufacturers develop items to be reused in a circular economy. Electrical gadgets, for example, can be built in such a way that they are easy to fix. Because the items are produced from raw materials, sold, consumed, and then disposed of as garbage, the process is referred to as "take-make-dispose." Products and raw materials are reused to the greatest extent feasible. Recycling plastic into pellets, for example, may be used to create new plastic items. A circular economy also requires that the environment is handled responsibly. For example, littering on the streets or in the natural environment should be avoided (Government of the Netherlands, 2020). Figure 2.9 shows how a circular economy would operate in the construction sector. Instead of moving linearly from extraction to disposal, circularity is introduced where prior to disposal, the material has the opportunity to be reused/repared in the first loop, re-machined/recycled in the second loop, and composted in the last loop. In the context of C&D waste, 'compost' refers to recovering energy from the waste. Since the material is reintroduced back into use stream and is not disposed of, all of the aforementioned loops are considered part of a circular economy. However, not all loops are equal, as there is an emphasis on smaller loops since they generate the most value with the least amount of inputted work. The ultimate objective is to shift away from a linear economy by enhancing the consumption of resources at every stage of the commodities and services' life cycle.

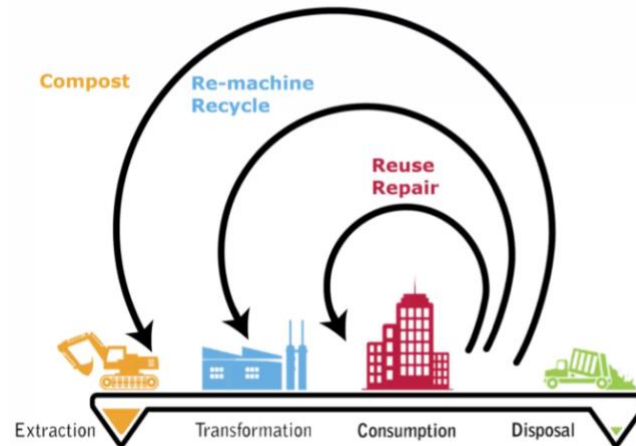

Figure 2.9 Model of Circular Economy (Polytechnique Montréal, 2019)

2.6 Reuse in the Steel Industry

The steel industry is not new to reuse. In 2006, a project report titled *Facilitating Greater Reuse and Recycling of Structural Steel in the Construction and Demolition Process* was conducted by Ryerson University. The project was supported by the Canadian Institute of Steel Construction and the Canada Action Plan 2000. The goal of the research was to investigate the material flows and mechanisms in the steel construction industry in order to better understand the possibilities for steel component reuse. Steel services centres, demolition contractors, salvage yards, designers, and steel fabricators were among the companies contacted and surveyed. In conclusion, the findings of that study show that steel component reuse occurs, although mostly informally and for secondary purposes.

Because they may adjust their needs to fit availability, the shoring sector is a significant consumer of larger reused pieces. Matching demand for certain components with what is available at any one moment is a challenge for other construction purposes. Furthermore, operational difficulties may limit the amount of reuse. Buildings that have been pre-engineered, primarily for industrial and storage purposes, are frequently demolished and reused. The value of scrap steel, health and safety laws, and construction economic activity are all important elements that influence steel reuse. Steel component reuse has been disincentivized economically due to the current high value of scrap steel on global markets. The cost of fresh steel determines the value of repurposed steel components. Since demolition contractors and salvage yards may earn a good price for scrap steel

that goes to steel mills for recycling, they are unwilling to devote to the extra work and expense of extracting the components in a way that they can be reused. Due to the more rigorous deconstruction methods required for steel components to be removed intact for reuse, health and safety requirements is frequently considered to add expense (Gorgolewski, 2006).

It is difficult to acquire precise numbers for the amount of steel recycled and reused during deconstruction. However, based on the study's discussions with the industry, it is estimated that approximately 90% of steel arising from demolition is recycled, about 10% is reused in some form, and only a small percentage, perhaps less than 1%, is disposed of in landfill because it is difficult to extract from the waste stream (Gorgolewski, 2006).

2.7 Previous Work

In this subsection, previous work in concrete reuse is explored. A summary of global research is provided, and existing guidelines are analyzed.

2.7.1 Global Research

In 2016, Brussels, Germany, introduced a few support measures to support circularity in their construction sector. The measures included financial and technical support for contractors transitioning to a circular economy; stimulating the construction sector and leading by example, so that the sector can move towards new standards; collecting data on material flows, so that the region can take advantage of economic development opportunities; and collecting input on the problems faced by the contractors in order to remove the roadblocks (Maerckx et al., 2019). As part of their "leading by example" mandate, they awarded 14 diverse circular construction projects to 14 contracting companies of various size (e.g., freelance, very small companies, small and medium size companies, and large companies). Figure 2.10 showcases the list of projects in order of their project size.

Project number	Project name	Main contractor	Type of work	Building type	Project size (approx.)
1	Petite Suisse	Max Stockmans	Extension	Housing	50 m ²
2	Clos Dupont	Eco Construct Groupe	Extension	Housing	55m ²
3	VLA	VLA-Architecture	Renovation	Offices	120 m ²
4	CoPost	Max Stockmans	Renovation	Housing	135 m ²
5	Warland	Global Art Concept	Renovation	Housing	150 m ²
6	Dethy	Bruno Duheym	Renovation	Housing and offices	270 m ²
7	Dépôt Leemans	DRTB	Extension	Housing and offices	300 m ²
8	Mouchérons	Florian Girault	Renovation	Housing	325 m ²
9	Boondaël	Ilyne Iliya	Renovation	Housing and shops	1000 m ²
10	Deswaef	Gillion Construct	Renovation	Culture	1000 m ²
11	Tivoli	BPC	Renovation & extension	Housing	1800 m ²
12	Tour à Plomb	Jacques Delens	Renovation	Culture	3000 m ²
13	Debatty	Gillion Construct	Renovation	Housing & kindergarten	5000 m ²
14	Horta-ONSS	Louis De Waele	Renovation	Offices	43000 m ²

Figure 2.10 List of the 14 Awarded Circular Projects (Maerckx, 2019)

The interpretation of circular economy as per the call for projects of ‘Be circular – Be Brussels’ is divided into two streams: management of human resources and management of material resources. Some of the circular measures under management of human resources were integrated team management from the initial phase of the project, focusing on the local workforce, and incorporating businesses that have a social purpose. Some of the circular measures under management of material resources included preserving existing buildings by promoting renovations, designing for change and disassembly, and giving a second life to construction materials with reuse. Not all 14 projects incorporated all the circular measures outlined, however, they state that all projects had the reuse measure applied.

Upon closer review of the reuse that was entailed in these projects, it was found that all were non-structural components. This makes some sense since several of the projects were renovations; however, even for the extension projects, no components were reused for their structural capacity. Examples of the components reused in the 14 projects included wooden flooring, marble panels, insulation, and partitions. The reason for this is not addressed in the overview study, although it can be construed that since implementing many of these measures is quite explorative in nature, contractors are more comfortable starting with lower risk (i.e., lower liability) reuse measures by opting for non-structural applications. This highlights a gap in the efforts towards a circular

economy since structural components are a key part of any infrastructure and are of substantial size, making them an ideal candidate for change.

In Taiwan, the introduction of circular economy strategies is slowly entering the country. Three circular building projects are the center of a 2019 study presented in Figure 2.11. To find trends in the collected data, this study used a comparative case study approach, as defined by Eisenhardt in 1989. Data was gathered over a 1.5-year period through interviews, stakeholder observations, and document analysis. Thirty people were questioned at different stages of the construction process, including the start, procurement, design, construction, and completion. Half of these stakeholders were questioned twice or three times to gain insight into the different stages of the process. The study does not divulge into the technical details of the projects, rather, it aims to define what the effective route and potential roadblocks for introducing circular buildings to a region that is new to the circular economy approach. In addition to the lack of technical input, this study is strictly focused on buildings and does not discuss other infrastructure that should also be part of the shift to a circular economy.

	Holland Pavilion	TaiSugar Circular Village	CE Social Housing Taipei
Location	World Flora Exposition, Taichung	High Speed Rail development area, Tainan	Nangang, Taipei
Function	Expo pavilion	429 households	1.545 households
Size	100m ² building + 600m ² plot	14.000m ²	77.800m ² (9 milliard ntd)
Client	The Netherlands Trade and Investment Office (NTIO),	Taiwan Sugar Corporation	Taipei City Government
Architect	JCS Architects (et al)	Bio-architecture Formosana	EcoLand & DeltaDevelopment
Procurement	January 2018	November 2017	February 2018
Opening	November 2018	July 2020 ^a	2022 ^a
End of first cycle	January 2019 ^a	2035 ^a	Not set

^a Expected date

Figure 2.11 Analysed Circular Building Projects in Taiwan (van Bueren et al., 2019)

In 2017, the Institute for Civil Engineering and Environment at the University of Luxembourg entered collaboration with the Suisse Federal Laboratories of Materials Science and Technology to conduct research on energy efficiency in the construction industry. Their first joint project, dubbed "Eco-Construction for Sustainable Creation," will focus on the development of innovative components and design models for resource and energy efficient structures made of concrete, steel,

and wood. The research, which appears to be still ongoing with not many details released, has diverged into seven work packages that are focused into different, yet interrelated, areas. The first work package is focused on the development of flexible architecture that facilitates deconstruction. This work packages closely connects with work packages 2 and 3 which looks at the development of new structural composite flooring systems based on the three main construction materials: concrete, timber, and steel. This is focused on new designs – not existing – therefore, it does not tackle how to deal with deconstructing and reconstructing existing flooring systems. Work package 4 aims to provide predictive modeling and integrated simulation of 3D concrete degradation. This could be extremely helpful as it allows professionals to anticipate the behaviour of concrete structures under different external circumstances and forecast their structural integrity over the course of their life. Work package 5 aims to shed light on an unexplored territory as it researches the energy efficiency and life cycle optimization of building elements in reusable modular building architecture. Work package 6 has the goal of developing building information modelling for buildings with one of the objectives being to simulate and optimize the construction and deconstruction procedures. This could be a very helpful measure for engineers interested in deconstructing existing structures or designing new construction with disassembly in mind. Work package 7 intends to offer a holistic interpretation of all previous work packages' contributions, as well as the creation of a material and component bank that will lead to the development of a pilot virtual building. A life cycle analysis on the level of this pilot building will be performed. This would be the culmination of the project and would likely be the most valuable portion for this research. However, since these studies are still in their infancy, not much has been made available online other than a few released journal and conference papers whose relevant results have been shared above.

In Finland, a project emerged in 2015 specifically looking into reusing prefabricated concrete panels from mass housing projects developed in the 1960s and 1970s. It notes that many of the housing that was built in that time period is now being either demolished or its demolition is in discussion in many countries, with sweeping demolitions occurring across Europe, particularly in the United Kingdom, Germany, France, and the Netherlands, as a result of vacancies caused by urban contraction and an attempt to reduce social division (Deilmann et al., 2009). As such, this pattern may result in an unexpectedly large volume of concrete waste. The conduct of this research

led to the discovery of a panel inventory typical of Finnish precast concrete construction (Figure 2.12). The panels are concluded to be still in a usable form for the architectural design of detached houses, which account for one-third of Finland's annual residential construction. This demonstrates how the mass housing of that time period constitutes a notable supply of building components that should not be overlooked. What is particularly noteworthy is the fact that the researchers did not anticipate such uniformities to emerge when inventorying the concrete panels from the mass housing projects. This is encouraging as it reveals that there could be more potential opportunities for reuse lurking elsewhere in unexpected places, especially noting that only 0.5% of the panels were incompatible with current room width guidelines (Huuhka et al., 2015). Because most floors were cast in situ, there were fewer slabs available than wall panels. This highlights how in situ casting can make the disassembly process more challenging. In fact, this is further highlighted by another study from Germany released in 2017 that concluded that it is feasible to convert a linear life-cycle model to a cyclic one by using design for disassembly criteria on precast concrete systems and elements (Salama, 2017).

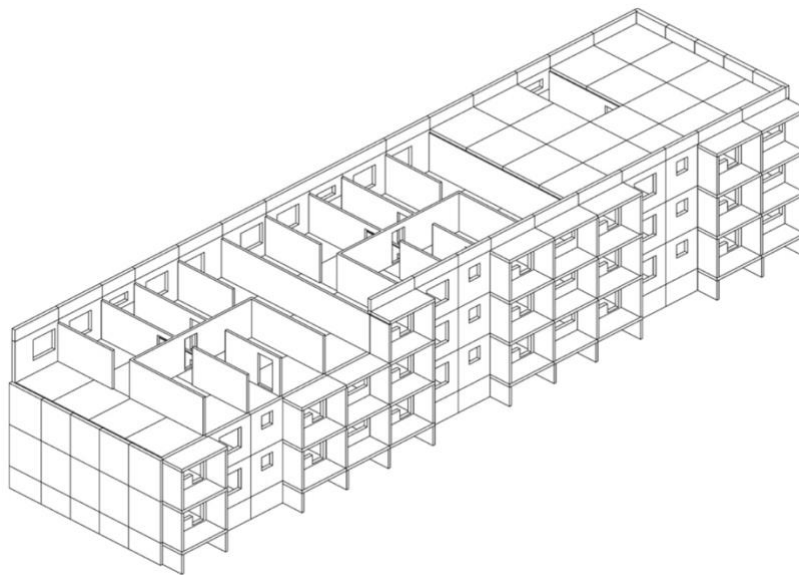

Figure 2.12 Typical Finnish Large-Panel Construction Used from the 1960s to 1975 (Mäkiö, et al., 1994)

The explorative review further discusses the reuse of elements for the same purpose and contrasts that with the reuse of elements for similar purposes. It notes that the most effective option for ensuring a cyclic loop is to reuse elements for the same purpose. As long as concrete elements are

classified as reusable, they can still be used for the same purpose for which they were designed. For example, load bearing elements such as columns, beams, and slabs could be reused in other projects for the same purpose. Concrete elements might potentially be utilised for purposes comparable to those for which they were developed. For example, wall panels might be utilised as sound barriers and fences along roadways near residential areas. They may also be utilised for landscape purposes such as walkways, platforms, and other structures. Concrete slabs might be utilised for highway sound barriers, fences, and other structures. Beams and columns could also be used for landscaping and fencing. Retaining walls, dams, and water barriers might all benefit from the reuse of suitable size footings (Salama, 2017). While this encourages retaining the structural elements to the same usage to maximize benefits, it also demonstrates that reuse can be flexible as the structural elements initial usage is not bound to determine its secondary life. Designing concrete elements and components for disassembly not only enhances their reuse prospects, but also expands the possibilities for their reuse.

The VTAA Technical Research Centre of Finland in collaboration with Tampere University of Technology released a document titled *Re-use of Structural Elements: Environmentally Efficient Recover of Building Components* in 2014. The goal of the study was to reduce building environmental impacts by encouraging the reuse of building components. The size and complexity of the part or structure being reused affects the reuse process, according to the researchers, who identified five categories:

- a) Buildings,
- b) Structures,
- c) Structural members,
- d) Basic structural components, and
- e) Building blocks

According to the research, higher-category building elements can be divided into many lower-category building elements. However, because higher category items are more valuable than the sum of their parts, separation is acceptable when finding a suitable application for higher category elements is challenging (Hradil et al., 2014). This makes sense since if smaller building elements are needed, more disassembly efforts are required which can be both time-consuming and costly.

With concerns surrounding the structural integrity of reused elements, a Polish study aimed to address those concerns by conducting laboratory tests for reinforced concrete hollow-core roof slabs that were 45 years old and pre-tensioned concrete I-girders that were 40 years old. The study assumed that only local loading was applied to the girders, whereas uniformly distributed, linear, and local loading was applied to the slabs. All tests conducted show that, despite their previous life in service, these elements are in acceptable shape and may be reused in other construction projects (Ajdukiewicz et al., 2013).

A United States study published in 2018 researched the life cycle energy and environmental benefits of a novel design-for-deconstruction structural system in steel buildings. The study concluded that their newly introduced flooring system designed for disassembly will still have lower environmental impacts than a traditional design even if no reuse occurs (Eckelman, et al., 2018). This demonstrates that reaping the benefits of design for disassembly is not necessarily delayed until the end of the first life cycle of a product and the start of its second, rather, the gains happen from the beginning. This is reassuring since if the components cannot be reused in the future due to damage or lack of financial incentives, environmental benefits are still observed. This is further reinforced by a different study from Italy released in 2019, that researched the environmental benefits arising from demountable steel-concrete composite floor systems in buildings. A demountable composite flooring system was compared against three conventional composite floor systems. The demountable designs opted for pretensioned high-strength friction grip bolts as shear connectors (illustrated in Figure 2.13) while the conventional designs used welded shear studs as shear connectors. The first kind encourages the end-of-life scenario of structural disassembly and reuse, whereas conventional systems are linked to current waste management techniques for building materials, such as demolition and recycling. As such, using demountable connections in structural design, like the one seen here, help pave the way for future reuse (Brambilla et al., 2019).

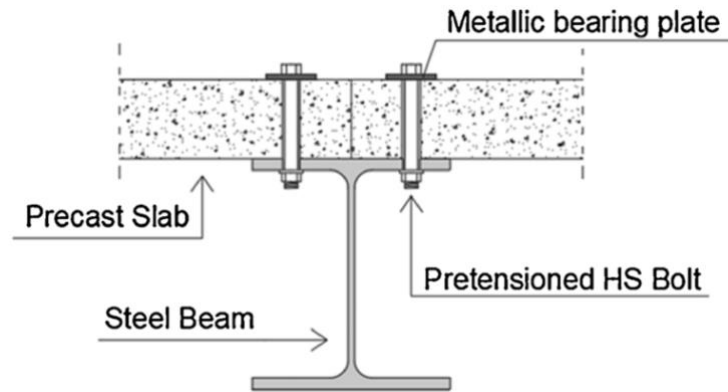

Figure 2.13 A Steel-Concrete Composite Beam with High-Strength Friction Grip Bolts (Brambilla, 2019)

A comparative Life Cycle Assessment of two full life cycles of the materials was designed to analyse these distinct structural systems. The building with a demountable composite floor system is recognized as the best environmentally friendly option among all the examined structural systems (Brambilla et al., 2019).

2.7.2 Existing Guidelines

2.7.2.1 Ontario Provincial Standard Specifications

The Ontario Provincial Standards for Roads and Public Works (OPS) organization produces a comprehensive set of standards for use by road and public works owners, contractors, and consultants in Ontario. Ontario Provincial Standard Specifications (OPSSs) and Drawings (OPSDs) are updated twice a year, in April and November. The Ministry of Transportation of Ontario (MTO) manages the publishing and electronic distribution of the OPS standards via this website, on behalf of the OPS. There are three specifications that are of interest to this research:

- OPSS.MUNI 180 General Specification for the Management of Excess Materials (Ontario Provincial Standard Specifications, 2016)
- OPSS.MUNI 510 Construction Specification for Removal (Ontario Provincial Standard Specifications, 2018)
- OPSS.MUNI 928 Construction Specification for Structure Rehabilitation – Concrete Removal (Ontario Provincial Standard Specifications, 2019)

Chapter 2: Literature Review

Table 2.1 highlights the scope of each specification and a commentary on its limitations. With regards to specification significance and use, all the specifications discussed above state that they are “written as a municipal-oriented specification” (Ontario Provincial Standard Specifications, 2019). Municipal-oriented specifications are developed to reflect the administration, testing, and payment policies, procedures, and practices of many municipalities in Ontario. The use of such specifications or any other specifications shall be according to the contract documents set out by the involved parties. Therefore, they are quite open ended in nature and do not offer guidance to interested parties on concrete reuse if that is something they wish to pursue for their project.

Table 2.1 Analysis of Relevant Specifications

Specification	Scope	Commentary
OPSS.MUNI 180	This specification covers requirements for the management of excess materials.	Section 180.07.02 details the Conditions on Management by Re-use. Part c) of the section states “re-use of concrete as aggregate in bituminous pavement” where the term reuse is actually referring to recycling. In Section 180.03, Definitions, it defines reuse as “using, processing, re-processing, or recycling of excess material into a construction material or other useful product.”
OPSS.MUNI 510	This specification covers the requirements for demolition, salvage, removal, and in-place abandonment, either completely or partially, of those materials and structures so designated, including the requirements for backfilling resulting excavations, trenches, holes, and pits.	Section 510.04.02.01 details the Removal of Bridge Structures. The section provides general guidelines on the sequence of removals for bridge demolition with no details on reclamation. Section 510.07.01.03 on Salvage states that materials indicated as salvage are the property of the owner and should be maintained in a practical condition and stockpiled in a way that is acceptable to the contract administrator. The standard does not provide ways to salvage material.
OPSS.MUNI 928	This specification covers the requirements for the removal of concrete from existing structures, except by means of pressurized water, hydro demolition, in order to facilitate structure rehabilitation.	This document has several sections details general guidelines on concrete removal of various components (e.g., deck soffit, abutments, pier columns etc.), however, the guideline does not specify the handling of those materials.

2.7.2.2 Canadian Standards Association Group

The Canadian Standards Association (CSA) Group is a standards development organization in Canada that conducts research and develops standards for a broad range of technologies and functional areas. It has developed standards in 57 areas and is accredited by the Standards Council of Canada. In 2006, they released Z782, Guideline for Design for Disassembly and Adaptability in Building (Canadian Standards Association Group, 2006). The short 22-page document was originally published in November 2006 and was later updated – very minimally – in August 2007 and September 2012. The guideline provides a framework for reducing building construction waste through design for disassembly and adaptability principles.

The guidelines notes that in addition to economic factors, the public is becoming increasingly aware of the importance of considering the environmental and social impacts in the design and operations of buildings. Therefore, there is mounting pressure on architects, developers, financiers, and owners to consider these metrics in their buildings. They stress that there is an increasing need for designers to consider design for disassembly and adaptability during the design phase of a building to allow for economic opportunities to deconstruct a building at the end of its life, or to adapt it to another potential use. Adding that project owners need to be attentive in overseeing these novel design methods being properly implemented by the contracts onsite.

The guideline pushes for the use of its design for disassembly and adaptability concept, the “DfD/A concept” in the design of new structures. While it recognizes that the details of disassembly and adaptability can vary from one building to the next, as well as between the various components present within a building, it argues that some principles do apply to all design choices related to adaptability and disassembly. The principles fall into two groups: those linked to adaptability and those linked to disassembly. Generally, adaptability principles “deal with functional use of space”, while disassembly principles “deal with the material base” (Canadian Standards Association Group, 2006). The details of those principles are explained below.

Adaptability Principles:

These design principles are noted to generally impact the long-term utility of a building from a functional standpoint, they include:

- a) Versatility: ability of a design to accommodate different functions with minimal changes
- b) Convertibility: ability of a design to accommodate substantial change in needs and use within the building by making modifications
- c) Expandability: ability of a design to accommodate substantial change (e.g., major renovation or new construction to add floors or expand space) (Canadian Standards Association Group, 2006)

Disassembly Principles:

These design principles apply to the assemblies and systems that are inside a building and that can be disassembled at the end of its life cycle, they include:

- a) Accessibility: ability to permit easy access to components for disassembly, refurbishment, replacement, or upgrade
- b) Documentation of disassembly information: practice of recording and making available important information, including labelling ingredients and compositions, construction sequences, disassembly instructions, and upgradability features that can ensure the success of disassembly and adaptability
- c) Durability: ability of a building or any of its components to perform its designed functions in its service life over a period without unforeseen cost for repair or maintenance
- d) Exposed and/or reversible connections: building connections that are left accessible for disassembly or modification and, in some instances, can even be disconnected for easy alterations and additions to structures
- e) Independence: quality that allows parts to be removed or upgraded without affecting the performance of connected or adjacent systems
- f) Inherent finishes: condition of material left in its most basic state without contamination by an applied finish that can prevent reuse or recycling activity

- g) **Recyclability:** characteristic materials that are separated and reprocessed from products and systems and subsequently used as material input into manufacturing processes for the same or different products
- h) **Refurbishability:** characteristic of a product designed to allow the consumer to renew the aesthetic and functional characteristics of the product to a condition suitable for continued use in its original form and function
- i) **Remanufacturability:** characteristic of a product that can be diverted from the waste stream at the end of its useful life, disassembled, repaired, and refabricated in a manner that provides a complete restoration to a condition suitable for resale by the original manufacturer or a second party
- j) **Reusability:** the quality of a material, product, or system that will allow use in its original form more than once and maintain its value and functional qualities during recovery to accommodate reapplication for the same purpose
- k) **Simplicity:** quality of an assembly or system to have as few components as possible and simple assembly steps and maintenance requirements, removing barriers to disassembly (Canadian Standards Association Group, 2006)

In its annex, the guideline provides an example of a feasibility assessment of design for disassembly options. The example shows how the design for disassembly and adaptability approach detailed by the guideline can be used in a mechanical system that includes ducting, diffusers, pipes, flexible tubing, and connectors. While this demonstration is specific to a mechanical system, the guideline encourages for similar assessments to be done on other elements present in the building. It advises that the tabular format can be used to evaluate early outline specifications to ensure that the design for disassembly and adaptability concepts are being addressed and to detect any prospects for enhancements.

While this guideline can apply to any type of building, be it commercial, industrial, institutional, and residential, it is important to highlight that this guideline only applies to buildings and does not divulge into other types of infrastructure, such as bridges. Consequently, while it is still a helpful measure that will propel the push for deconstruct-able and adaptable design in the industry, it will be limited to a single domain; therefore, it should be expanded to other infrastructure areas

to create a larger impact. Lastly, it is important to note that this guideline is a guidance document only, and it is not intended to be used for certification or registration purposes.

2.8 Challenges

With his extensive research on steel reuse, Gorgolewski states that when reused components are incorporated, the greatest environmental benefits are realised. He notes that by specifying them, greenhouse gas emissions and embodied energy are reduced significantly. However, because of the supply chain's variability, there is a price to be paid for reused resources. This is related to current supply fluctuations, and it implies that the greater environmental advantages achieved by reusing components may come at a cost (Gorgolewski, 2006). The same can be said for concrete.

Gorgolewski is shedding light on two important issues: logistics and finances. For concrete, these issues are further exacerbated by the lack of comprehensive research available on this material. Unlike steel, the reuse of concrete members is still in its very early stages of development for many countries around the world. Therefore, it is not clear how much of an expense or how complex the logistics would be when reusing concrete. It is obvious, however, that concrete will be more demanding as it is significantly heavier than steel. More studies are needed to understand the impacts of reusing concrete both financially and logistically in construction projects.

From a technical standpoint, there is not much research available on dealing with existing structures and attempting to deconstruct their components and later connecting them effectively. Most of the existing research focuses on reuse of non-structural components for non-structural applications. The industry seems to be apprehensive about reusing concrete components for structural applications likely due to liability issues and a concern about the structural integrity of those members as they enter a second usage life.

2.9 Opportunity in Canada

Canadian Infrastructure periodically releases the Canadian Infrastructure Report Card (CIRC) that monitors the state of Canada's core public infrastructure. The report card focuses on seven different categories of infrastructure: potable water; wastewater; stormwater; roads and bridges; solid waste; culture, recreation, and sports facilities; and public transit. It reports that "the state of

our infrastructure is at risk”, and that this “should be cause for concern for all Canadians” concluding that to adapt, Canadian public infrastructure “will require significant attention in the coming decades” (BluePlan Engineering, 2019). As observed in Figure 2.14, nearly 40% of Canada’s bridges are in fair, poor, or very poor conditions – this is circled with a red dashed line.

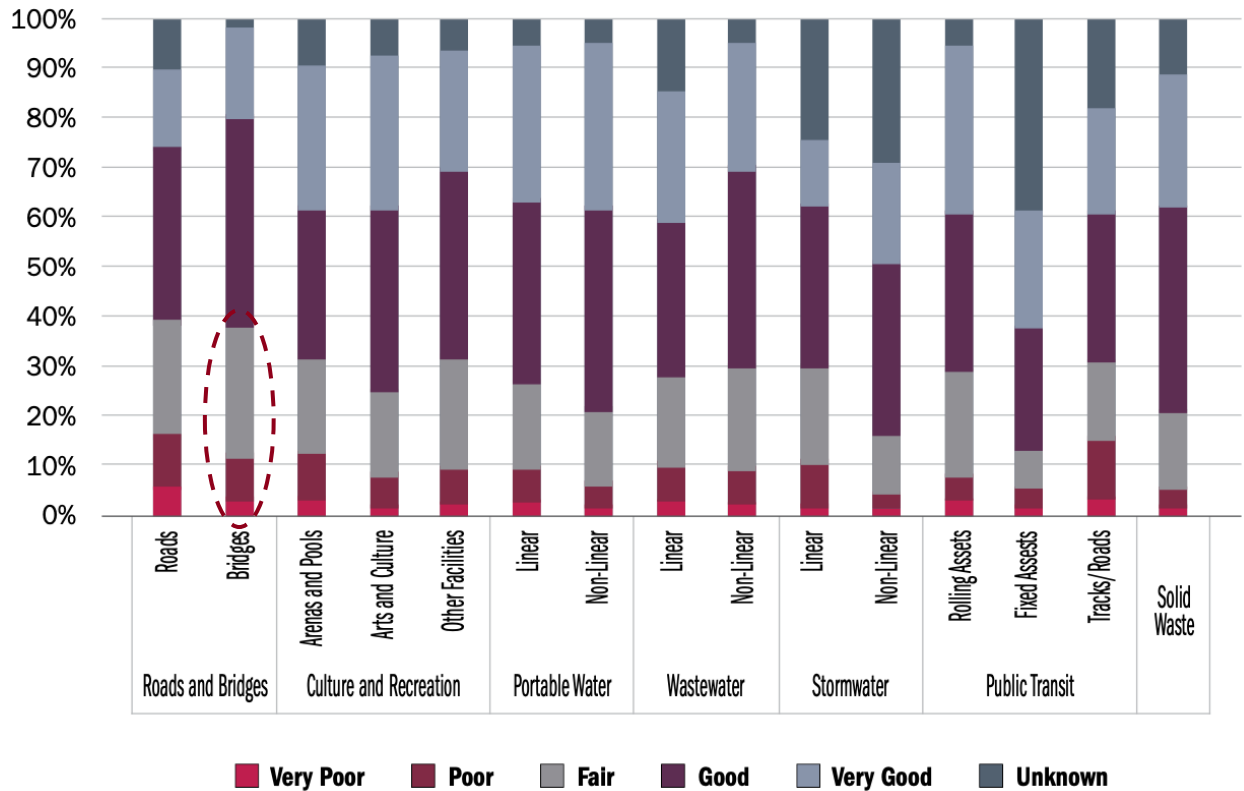

Figure 2.14 Core Infrastructure Asset Condition Summary (BluePlan Engineering, 2019)

To collect its data, the CIRC releases its Canadian Core Public Infrastructure Survey (CCPIS) to municipalities to assess the status of their infrastructure. The methodology used in this survey consists of a condition rating scale with five different conditions that are explained below (BluePlan Engineering, 2019)

- **Very poor:** The asset is unfit for sustained service. It is near or beyond its expected service life and shows widespread signs of advanced deterioration. Some assets may be unusable.
- **Poor:** There is an increasing potential for its condition to affect the service it provides. The asset is approaching the end of its service life, the condition is below the standard and a large portion of the system exhibits significant deterioration.

- **Fair:** The asset requires attention. The asset shows signs of deterioration and some elements exhibit deficiencies.
- **Good:** The asset is adequate. It is acceptable and generally within the mid-stage of its expected service life.
- **Very Good:** The asset is fit for the future. It is well maintained, in good condition, new or recently rehabilitated.
- **Unknown:** Not enough data exists to respond.

With these definitions in hand, it might not be suitable to reuse infrastructure that is labeled as very poor or poor as its condition is substandard and demonstrates serious signs of deterioration. However, it is important to note that even a structure in poor condition overall may have many structural components that are in good condition. Infrastructure that is in fair condition may present more components to be reused. Bridges in this condition make up 26.3%, which is a considerable sum (BluePlan Engineering, 2019). It worth noting that not all decommissioned bridges are in fact decommissioned due to poor condition. In the United States, a common finding in previous studies was that a substantial portion – approximately 15-30% – of decommissioning could not be linked with any specific reason. Although poor condition is an important factor, the main driver of bridge decommissioning is functional improvement, and this explains the majority of the unexplained cases. Structures changed due to functional motives tend to be changed at a younger age, causing a reduction in the total decommissioning age (Bektas & Albughdadi, 2019). Therefore, this presents an opportunity to reuse bridge structure components that were decommissioned early in their service life due to functional changes. Elements of these bridges could start a second life in new construction.

In 2004, the results of a demolition survey of buildings that were demolished between 2000 and 2003 in a major North American city were published. The study collected data for a total of 227 buildings that were demolished during that three-year period. Over 50% of all the demolished concrete buildings were only 26-50 years old (O'Connor, 2004). The study concludes that “most buildings are demolished for reasons that have nothing to do with the physical state of the structural system” with only 8 buildings out of the 227 buildings in the study being demolished due to structural failure – this accounts for a mere 3.5%. As is the case with bridges, reasons of demolishing were rarely related to actual useful life of the building. Instead, they were related to

changes in land prices, the building's suitability for modern demands, and the lack of upkeep of different non-structural components present in the building (O'Connor, 2004). This presents itself as major opportunity for reuse.

Lastly, it is important to recognize that anytime a structure is being designed and constructed today, it is potentially a huge resource for materials that can be salvaged in future construction projects to be recycled, or better yet, reused. The key is to integrate disassembly and adaptable design into the initial phases of a project when it is still cost-effective to do so.

2.10 Research Needs

While there have been survey studies done on steel reuse and its perception in the Canadian construction industry, this not been done for concrete. It is not clear if there is concrete reclamation happening in Canada and to what degree. It is important to differentiate the reclaimed concrete being recycled and reused to understand how much, if any, of the concrete is being reused. Moreover, it is critical to understand current perceptions of concrete reuse in the industry to see what challenges they face and what benefits they perceive from such a practice.

Modern infrastructure is typically not designed with the intention for it to be disassembled or adapted later in its life. While there is now a slight shift towards incorporating design for disassembly concepts early in the planning and design phase, as highlighted in the global research shared earlier, much of the infrastructure in the existing built environment has not been designed or constructed in a way that promotes easy dismantling of its building components. As such, a need for conceptual case studies to address how to deconstruct infrastructure that has not been designed for disassembly and later assembled effectively emerges. This presents itself as the second objective of this thesis, which is to take existing structures that have not been designed with disassembly in mind and explore how to deconstruct those structures and then reconstruct them in hypothetical – ‘new’ – redesigns.

There is a lack of guidelines available to support reuse of concrete. If designers are interested in incorporating these design practices into their projects, they do not have sufficient technical support available to them. Moreover, there is a lack of extensive experimental testing on reused concrete components and their connection strategies. This is required to promote confidence in the

Chapter 2: Literature Review

structural integrity of those reused components. Beyond those basic guidelines, there is also a demand to have comprehensive design codes to facilitate design for disassembly and reused component design. The present research intends to take a first step towards this long-term goal.

3 Chapter 3: Survey

3.1 Background

To better understand current perceptions regarding the feasibility of concrete reuse and associated challenges, a survey was created and dispatched to several key groups within the concrete industry. The content of the survey was essentially broken down into five different components as shown in Figure 3.1. The *Introduction* component included welcoming remarks, an overview of the research, background of the researchers, and links to the Certificate of Ethics Approval and Implied Consent Form. This was followed by a *Terminology* section, where important vocabulary was defined to differentiate between key concepts—such as recycling and reuse—and schematic drawings were added for additional clarity. Participants were then invited to provide responses in the *Questions* section, followed by an opportunity to share additional thoughts and suggestions (*Comments and Feedback* component). Finally, in the *Contact Information* component, the participants were given the option to share their name and personal or professional contact information. The full content of each component of the survey is detailed in Appendix A.



Figure 3.1 Breakdown of Survey Content

3.2 Objective

The survey was created primarily to answer three overarching questions:

1. Is the concrete industry currently doing any reclamation (recycling and/or reuse)?
2. If yes to the previous question, then to what degree? And if not, why is that?
3. What is the perception of professionals on concrete reuse? What are the perceived benefits and challenges of such a practice?

3.3 Methodology

Based on the three objectives outlined in the previous subsection, the survey questions were drafted. Some of the questions in the survey were inspired by the *Facilitating Greater Reuse and Recycling of Structural Steel in the Construction and Demolition Process* study published in 2006 by Dr. Mark Gorgolewski from Ryerson University. These questions, originally written for steel, were adapted to the concrete industry and modified to the research objectives of this study. Ahead of release, the survey questions were reviewed by concrete industry professionals for feedback to maximize effectiveness of the gathered data. SurveyMonkey, an online survey development cloud-based software service, was used as the platform to launch the survey. Various social media platforms were used to disseminate the survey to participants. Email invitations were also sent to relevant individuals, companies, and agencies. LinkedIn proved to be a very useful avenue to reach concrete professionals active in the industry. A \$50 e-gift card draw was put into place to incentivize participants to complete the survey.

The survey was open Canada-wide. Out of 125 total participants only 56 (45%) provided location information with 46 entries noted to be in Ontario. Another 8 were from other Canadian provinces including Quebec (3), Alberta (3), and British Columbia (2). Moreover, since the survey was shared online, there were a few responses from outside of Canada. Of the 56 individuals who provided location information, 2 were outside of Canada, specifically in India and United Arab Emirates. The remaining 69 participants opted not to share their location information. Table 3.1 provides a summary of the geographic distribution of participants.

Table 3.1 Location of Polled Participants

Ontario		Other Canadian Provinces		International		Unknown	
Number	Percentage	Number	Percentage	Number	Percentage	Number	Percentage
46	36.8	8	6.4	2	1.6	69	55.2

3.4 Results

3.4.1 Identification of Polled Participants

With concrete reuse being a relatively novel concept, it is critical to have a holistic and comprehensive understanding of the benefits and barriers perceived by the various stakeholders in the industry. Therefore, the survey design was divided into four streams corresponding to the following categories of the respondents:

- Concrete Professional (e.g., design engineer, consultant, and/or quality control)
- Concrete Structure Owner (e.g., municipality, provincial or federal agency, and/or private owner)
- Concrete Supplier (e.g., precast, ready-mix)
- Concrete Contractor (e.g., builders, demolishers)

The first question in the survey asked each respondent to self-identify with one of the above groups that best described their primary responsibilities. Each stream had its own set of personalized questions, while some common questions were asked to multiple groups. Participants from the first two streams, Concrete Professional and Concrete Structure Owner, were further divided into two sub-groups based on whether their company or agency had any experience incorporating reclaimed concrete on a previous project. If they answered “Yes”, they were questioned further about their experience of concrete reclamation. If they answered “No”, they were questioned on their thoughts, perceptions, and considerations of the possibility of reusing reclaimed concrete in future projects. The questions later converged for both the “Yes” and “No” participants to inquire further about their views on the obstacles of concrete reuse, the perceived benefits of concrete reuse, and the potential structural applications of reused concrete. The overall survey design is outlined in Figure 3.2.

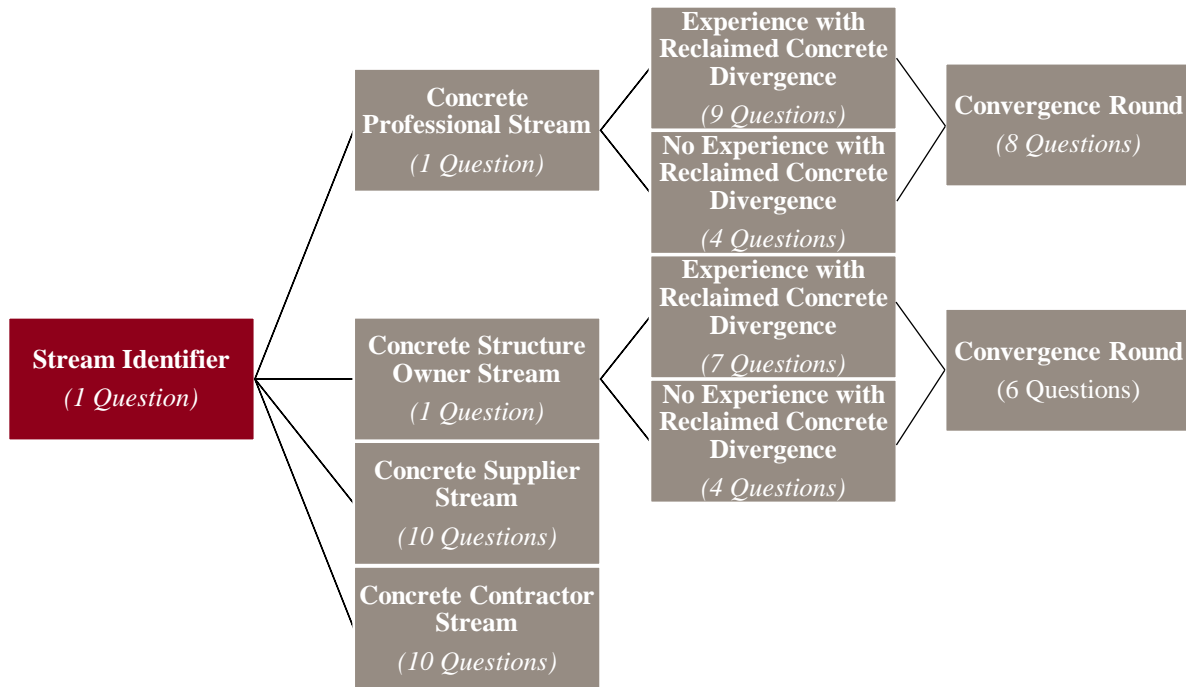

Figure 3.2 Breakdown of Questions

The results of the *Identification* question are shown in Figure 3.3. Most of the respondents (78%) identified with the Concrete Professional category as this was the broadest category whereas the others were rather specific. Moreover, connecting to professionals in that category tended to be more accessible due to a stronger LinkedIn presence.

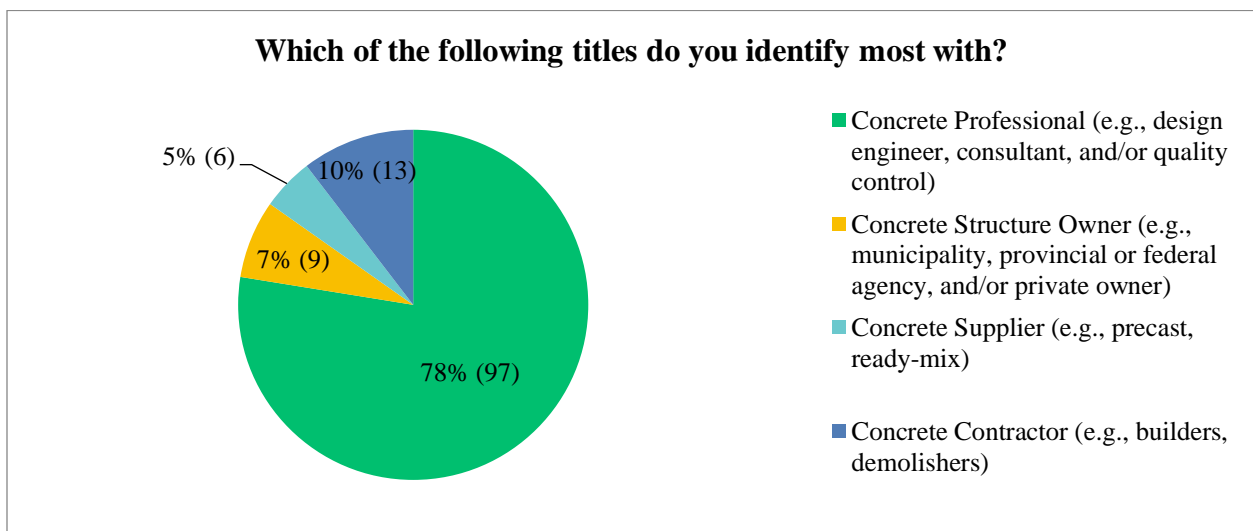

Figure 3.3 Breakdown of Polled Participants

A total of 125 individuals attempted the survey, of which 80 (64%) participants completed every question. All data from responses, including incomplete entries, are presented; in cases where questions received a small number of responses the results may not be representative of the broader industry in a quantitative sense, but they do provide anecdotal evidence of current perceptions. For example, results for the Concrete Supplier may not be conclusive due to smaller numbers.

3.4.2 Concrete Professional Stream: Results & Analysis

The Concrete Professional stream includes those who identify as, for example, design engineers, consultants, or quality control engineers. The first question in this stream divided the participants into subgroups based on whether their company had any experience incorporating reclaimed concrete on a previous project. Eighty-three participants answered this question with 20 (24%) having some previous experience and 63 (76%) having no experience, demonstrating that most are unfamiliar with reclaimed concrete since their companies likely do not incorporate reclaimed materials.

3.4.2.1 Experience with Reclaimed Concrete Subgroup

In this divergence of the Concrete Professional stream, participants with previous experience using reclaimed concrete were asked specific questions relating to their experience. When asked approximately what percentage of the projects undertaken last year incorporated reclaimed concrete in some form, the average answer from 13 participants was 27%, with 0-9% being the most frequent response. The distribution of their responses can be observed in Figure 3.4.

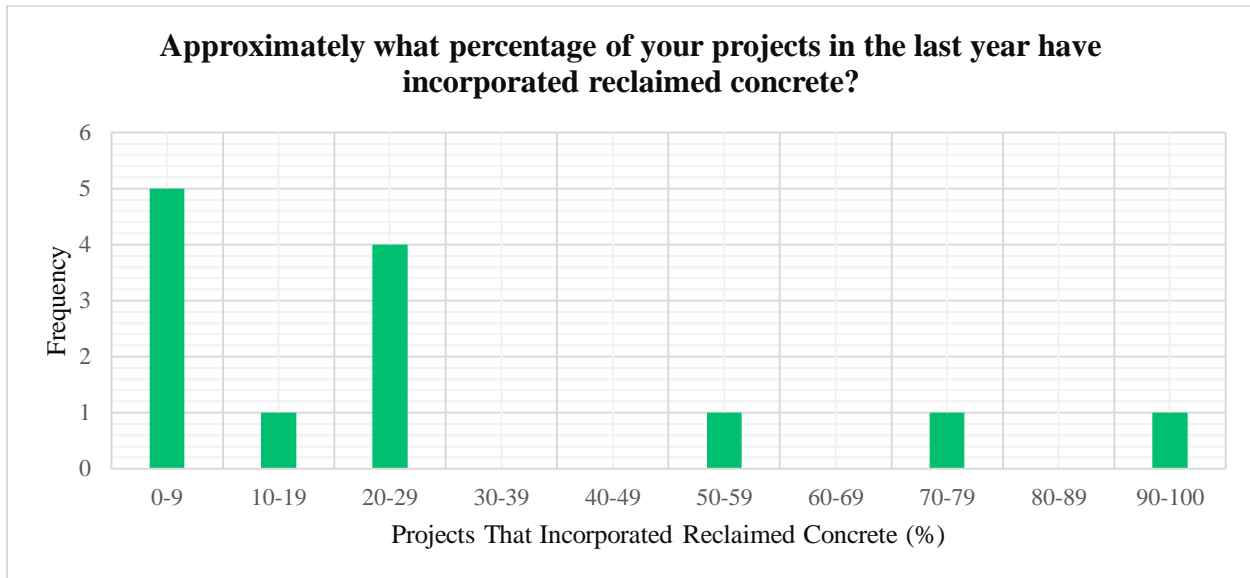

Figure 3.4 Distribution of Responses of Projects That Incorporated Reclaimed Concrete

The participants were also asked to distinguish whether the reclaimed concrete was reused (in its original form) or recycled (i.e., crushed for aggregate or base material) and at what percentage. Figure 3.5 summarizes the breakdown of reclaimed concrete. The proportions of reclaimed concrete that were either reused or downcycled were quite low; only 21% of participants claiming to have experience with reclaimed concrete reused 60% or more, and only 7% recycled more than 60% of their material. Most participants reused or recycled less than 20% of the reclaimed concrete. This suggests that even among industry leaders that strive to reduce waste and are conscientious about the environmental impact of their concrete use, most of it still ends up being disposed as waste in landfills. It also is a bit surprising that, according to these results, a slightly greater proportion of concrete was reused than recycled. It is possible that due to the survey's name, *Reuse in the Concrete Industry*, it attracted more professionals who are familiar with the reuse of concrete and as such, had more experience with it. It is also worth mentioning that the applications in which the reclaimed concrete was used were not specified in this question; it is considered unlikely, in the context of the following question, that the reused concrete was used for structural applications.

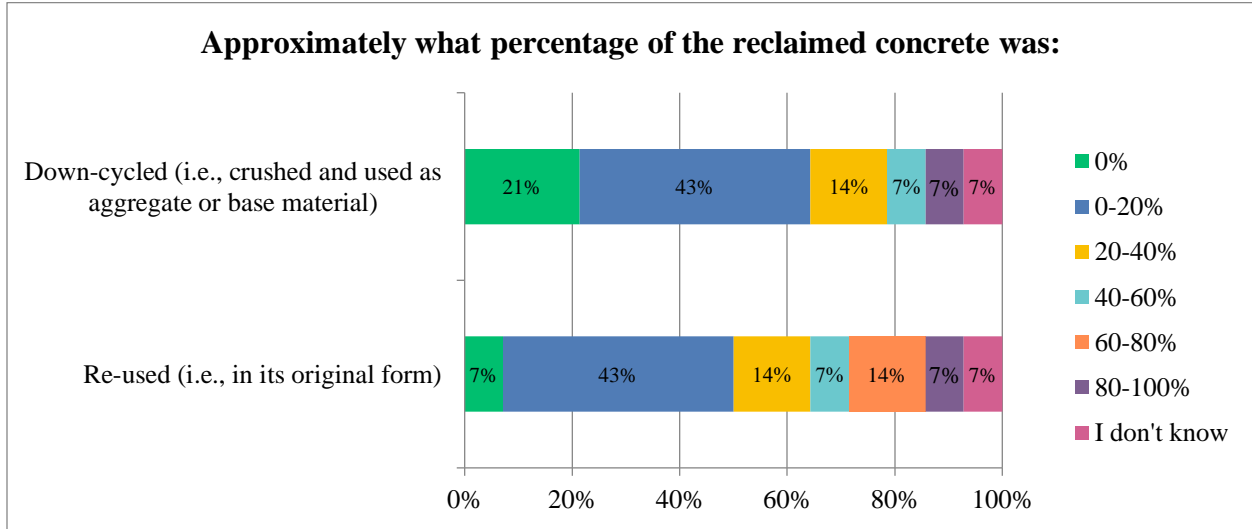

Figure 3.5 Breakdown of Reclaimed Concrete

Participants were then asked about the purpose or application of the concrete that they reclaimed. The data collected from this question is presented in Table 3.2. For “Other”, one response was received which was specified to be for a research project. The top three responses were *Base material* and *Non-structural applications*, followed by *Aggregate in concrete* and *Public infrastructure*. This demonstrates that reclaimed materials are not fully trusted to provide adequate structural performance in practice.

Table 3.2 Breakdown of Usage of Reclaimed Concrete

For what purpose(s) or application(s) did you use reclaimed concrete?		
Check all that apply:		
Answer Choices	Responses	
Base material	43%	6
Non-structural applications (e.g., drainage)	36%	5
Aggregate in concrete	29%	4
Public infrastructure	29%	4
Commercial construction (e.g., office space or warehouse)	21%	3
Residential construction (e.g., apartment building)	7%	1
I don't know	7%	1
Other (please specify)	7%	1
	Answered	14

The professionals were then further asked if they knew the sources of the reclaimed concrete used in their projects. Eight answered “Yes”, 2 stated “No”, and 4 stated “I don’t know”. Those who answered “Yes” were then asked to specify the source of the reclaimed concrete; as summarized in Table 3.3, the concrete mostly came from demolished, dismantled, or deficient existing structures or components.

Table 3.3 Sources of Reclaimed Concrete Specified

Respondents	Responses
1	Crushed concrete from demolished structure
2	AAC block and dismantled concrete
3	From a supplier
4	Deficient precast structures
5	Existing RISI wall units (retaining walls)
6	Demolished buildings foundation used as fill in the hole left behind
7	Existing structure
8	Curbs and gutters being replaced

The participants were later asked if they would consider using reused concrete (i.e., in its original form, not downcycled) in future projects; 10 responded “Yes”, 0 said “No”, and 4 said “Maybe”. These results are promising as they show a general willingness and openness to the concept of reuse among concrete professionals that have at least some previous experiences with reclaimed concrete. When further asked why, why not, or why maybe, all 10 participants elaborated. The statements “save cost”, “cost effective”, and “more economical” appeared, demonstrating that there is a perceived financial benefit. Practicality was highlighted on two occasions, with one respondent stating that it would be useful in northern communities where it is otherwise difficult to deliver bulk materials like aggregates. However, there does seem to be low confidence in reused concrete with participants stating that it would be useful for barriers and temporary uses and another stating that they would limit its use to non-structural applications such as boulevards, planters, paver stones, etc. One respondent stated that they need to know more about the concrete before deciding.

The following question asked participants if they were aware of any technical documents (i.e., standards, codes, guidelines, etc.) related to the reuse of concrete. Four participants answered “Yes”, 7 answered “No”, and 2 answered “I don’t know”; this translates to 29% having knowledge of available resources and 71% lacking that knowledge. When the 4 participants with awareness of technical documents were asked to share the titles of those documents, one could not recall from memory, and another stated the Ontario Provincial Standard Specifications municipal standards. The other two respondents did not specify which resources they were familiar with. As noted in the previous chapter, the Ontario Provincial Standard Specifications were found to have limited relevance or helpfulness as technical guidance for concrete reuse. Hence, there is a clear lack of technical guidelines to aid engineers that are interested in incorporating reused concrete in future projects.

3.4.2.2 No Experience with Reclaimed Concrete Subgroup

In this divergence of the Concrete Professional stream, participants having no experience with reclaimed concrete were asked questions on their thoughts, perceptions, and considerations of the possibility of reusing reclaimed concrete in future projects. The first question asked if they would consider using reclaimed concrete (either reused or recycled) on a future project: 27 (48%) said “Yes”, 3 (5%) said “No”, and 26 (46%) said “Maybe”. While the results are promising in that only a small proportion of respondents were firmly opposed to using reclaimed concrete, it is worth noting the approximately 50%-50% split between “Yes” and “Maybe”. This is visually illustrated in Figure 3.6 and highlights the uncertainty that professionals face in this regard.

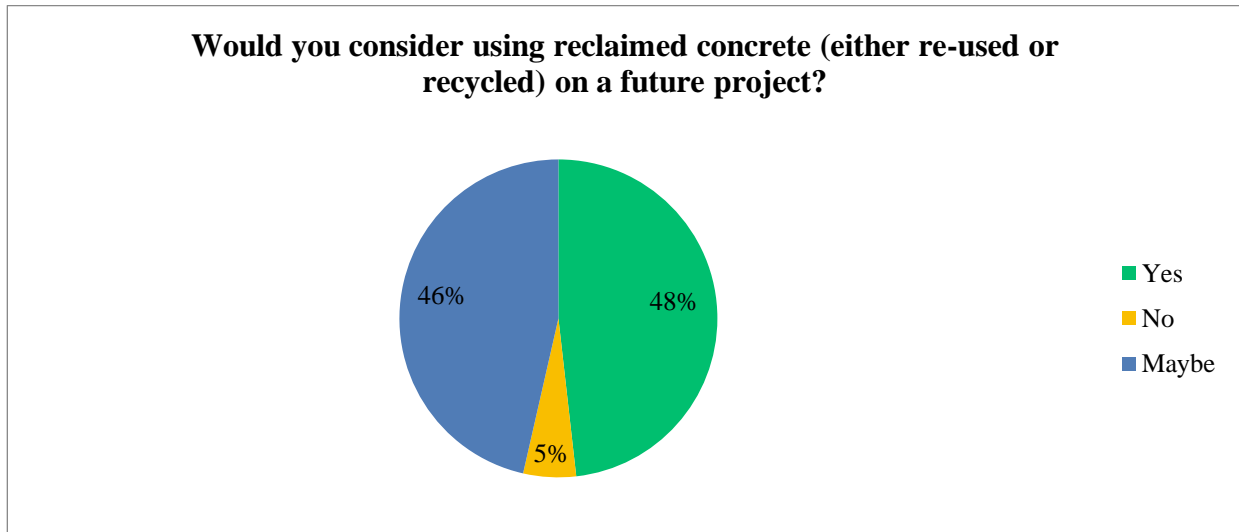

Figure 3.6 Willingness of Participants to Using Reclaimed Concrete on a Future Project

The follow up question asked participants to share their reasoning, asking “Why, why not, or why maybe?” Forty-eight participants elaborated; the highlights of their answers are outlined in Table 3.4. The comments were organized into five different key concepts seen in column 1: Structural Integrity, Environmental Sustainability, Financial Considerations, Design Constraints, and Other Limitations. In the second column, the Number of Appearances is provided. The count gives insight into how many unique participants flagged this concept in their comments and ranks the concept in order of its relevance based on the commentary. In the last column, Context of the various comments is given. They are subdivided into positive comments, neutral comments, and negative comments. The positive comments express support to and/or benefits of the concept, neutral comments present impartial feedback or conditional considerations, and negative comments offer opposition and/or challenges to the concept. Each comment in the various subdivisions is ranked based on how many participants mentioned it. The number of times it appears in the submitted responses is written in parentheses at the end of the comment.

Table 3.4 Analysis of Commentary on Consideration of Using Reclaimed Concrete

Key Concept	Number of Appearances	Context
Structural Integrity	26	✓ Openness to the possibility of using reclaimed concrete for non-structural applications (2)
		✗ Concerns of reclaimed concrete meeting strength requirements (8)
		✗ Challenges in ensuring the structural integrity of reclaimed concrete (6)
		✗ Questions about the performance levels of reclaimed concrete (4)
		✗ Worries about quality of reclaimed concrete (3)
		✗ Concerns about deterioration of reclaimed concrete (3)
Environmental Sustainability	21	✓ Environmental benefits when reclaiming concrete (11)
		✓ Reducing embodied carbon and greenhouse gas contribution (3)
		✓ Support of sustainability when reclaiming concrete (4)
		✓ Importance of sustainability in work or at company (3)
		✓ Reduction of waste using reclaimed concrete (2)
		✓ Satisfaction of LEED requirements of some institutional clients, for example government, municipal, or large corporations (1)
Financial Considerations	15	✓ More environmentally efficient (1)
		✗ Difficulties for clients to value reduction in greenhouse gas emissions (1)
		✓ Perception of economic benefits of saving money using reclaimed materials (6)
		- Citing client budget as the deciding factor when moving towards concrete reclamation (5)
		- Citing that price of reclaimed material need to be competitive (5)
		- Citing questions about cost effects of concrete reclamation (3)
Design Constraints	13	✗ Concerns about premiums in cost when using reclaimed concrete (3)
		✗ Concerns of price fluctuation of reclaimed materials (1)
		- Need to meet company policies when using reclaimed materials (1)
		- Need client approval and confidence in the design when using reclaimed materials (1)
		✗ Citing the need to meet code standards before using reclaimed concrete (4)
		✗ Need to meet strict material requirements (1)
		✗ Might not meet all industry requirements (in the nuclear industry there are stringent and robust requirements for concrete material that recycled material might not adhere to) (1)
		✗ Design challenges associated when using reclaimed materials (4)
		✗ Unique geometry of new construction (1)
		✗ Unclear load path (1)
		✗ Unknown additional considerations to regard (1)
		✗ Limitations with software to support reclaimed concrete applications (1)
		✗ Lack of knowledge of reclaimed material behaviour (1)
✗ Lack of first-hand experience in engineers and contractors to use reclaimed concrete (1)		
✗ Knowledge limited to recycled concrete only (1)		
Other Limitation	4	✗ Concerns about scheduling, citing that time is very important in this sector of work and that there are uncertainties of delay when reclaiming concrete (1)
		✗ Concerns about logistics: citing uncertainties of material's availability and reliability (1)
		✗ Concerns about gaining support from client to move towards concrete reclamation: citing that lack of experience in this field would be difficult for the consultant and contractor (1)
		✗ Concerns about additional liability assumed by consultant and/or contractor when using reclaimed concrete (1)
		✗ Questions about additional considerations the contractor needs to be aware of when dealing with reclaimed materials (1)
		✗ Citing the need for guidance of the parties involved in concrete reclamation to facilitate the process and allow the engineers and contractors to gain confidence in this novel application (1)

- ✓ Positive comments
- Neutral comments
- ✗ Negative comments

The next question further elaborated on the type of reclaimed materials by asking if the professional would consider using concrete in its original form – not down-cycled as crushed aggregate or base material – for future projects. 56 participants answered this question with 34 saying “Yes” and 22 saying “No”; the percentages are depicted in Figure 3.7.

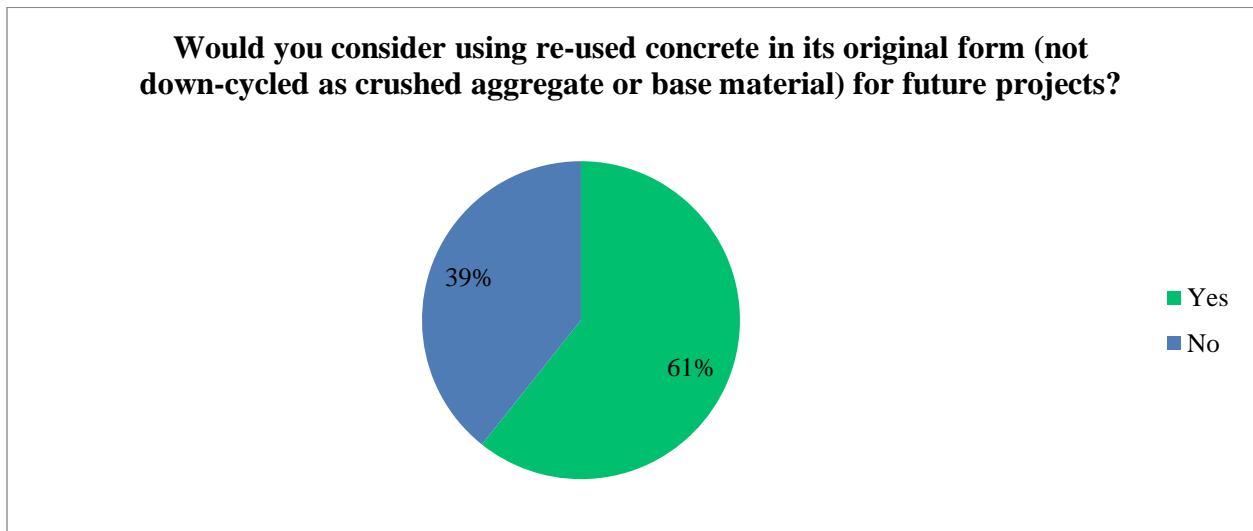

Figure 3.7 Willingness of Participants to Using Reused Concrete on a Future Project

The follow up question asked participants to share their reasoning, asking “Why, why not, or why maybe?” Forty-two participants elaborated; the highlights of their answers are outlined in Table 3.5. Five participants cited that they felt the same about reused concrete as they did with reclaimed concrete in general.

Table 3.5 Analysis of Commentary on Consideration of Using Reused Concrete on a Future Project

Key Concept	Number of Appearances	Context
Design Constraints	21	<ul style="list-style-type: none"> ✓ Openness to consider alternative solutions when reusing concrete (1) ✓ Stating that reused concrete can be used in masonry structures (1) ✓ Citing that abutments, piers, and piles are often reused for bridge replacements (if adequate) and only the super structure is replaced (1)
		<ul style="list-style-type: none"> - Openness to reused concrete depending on the suitability of application or project (4) - Openness to reused concrete for non-structural applications or structures with small loads (1) - Openness to reused concrete if it were industry wide standardized practice (supported by data) for proper removal, transport, and re-installation (1) - Openness to reused concrete for temporary usage during construction (1) - Openness to reusing concrete if it meets code requirements (1) - Openness to reusing concrete if it provides aesthetic value (1)
		<ul style="list-style-type: none"> * Design challenges associated when using reused concrete (5) <ul style="list-style-type: none"> * Unique geometry of new construction, limitation in shapes (2) * Original form may not be used on all occasions (1) * Citing it does not fit for building design (1) * Original form would not be as versatile (1) * Lack of knowledge of viable and practical applications (2) * Citing the need to meet material requirements before using reused concrete (1) * Citing that reused concrete would be used likely only for non-critical zones (3) <ul style="list-style-type: none"> * Likely not used for primarily load bearing structural elements (1) * Likely used in non-structural elements or for secondary elements (1)
Structural Integrity	9	<ul style="list-style-type: none"> - Openness to concrete reuse if it meets requirements (3) <ul style="list-style-type: none"> - Meets strength and property requirements (1) - Has adequate capacity (1) - Openness to concrete reuse if data about existing material can be obtained (1)
		<ul style="list-style-type: none"> * Citing that reusing concrete would be less efficient (3) <ul style="list-style-type: none"> * Stating that it is easier to incorporate crushed concrete as aggregate into the production of concrete to control performance of new structures (1) * Stating that if the materials can be broken down, it would be more effective in production of concrete (1) * Concerns of reused concrete meeting capacity requirements (2) <ul style="list-style-type: none"> * Need for significant capacity reductions of reused concrete to meet code * Concerns about deterioration of reused concrete (1) <ul style="list-style-type: none"> * Stating that reuse of reinforced concrete would pose an issue for service life (1) * Uncertainties of the durability of reused concrete (1) * Challenges of reusing concrete without impacting its strength (1)
Environmental Sustainability	8	<ul style="list-style-type: none"> ✓ Environmental benefits when reusing concrete (5) <ul style="list-style-type: none"> ✓ Reducing embodied carbon and greenhouse gas contribution (1) ✓ Reducing energy usage and emissions released (1) ✓ Support of sustainability development when reusing concrete (1) ✓ Contribution to LEED credits (1) ✓ Citing that reuse is a better alternative than wasting it (1)

Table 3.5 Continued

Financial Considerations	5	✓ Perception of economic benefits of saving money using reused materials (3)
		<ul style="list-style-type: none"> - Openness to reusing concrete provided it saves costs (1) - Citing that price of reclaimed material need to be comparable or better than new (1)
Other Limitations	5	<ul style="list-style-type: none"> ✗ Lack of expertise (1) ✗ Need to settle the culture of concrete reuse among the contractors (1) ✗ Involves too much risk (1) ✗ Need for client to be fully on board (1) ✗ Citing that reusing concrete is an additional liability that is not necessary (1)

- ✓ Positive comments
- Neutral comments
- ✗ Negative comments

3.4.2.3 Questions for Both Subgroups

In this set of questions, both divergences of participants, those with experience with reclaimed concrete and those without experience with reclaimed concrete, were presented with the same questions. The questions focused on their overall perceptions of the concept of concrete reclamation, and more specifically, concrete reuse.

When the participants were asked if they consider reuse of structural concrete components in an acceptable condition for new construction projects to be feasible, 65 participants answered; the breakdown of responses is outlined in Figure 3.8.

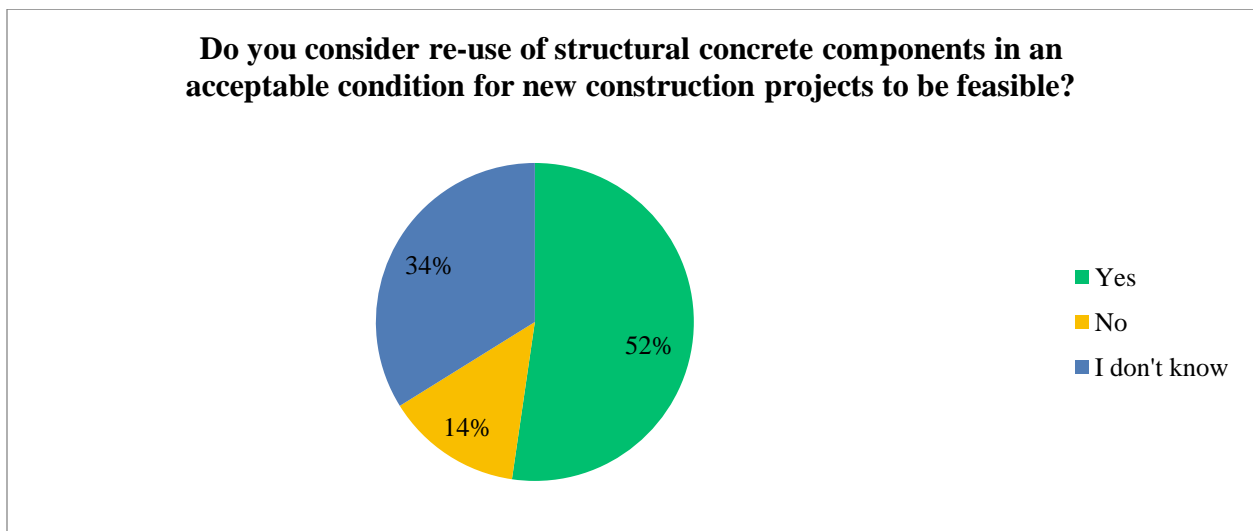

Figure 3.8 Breakdown of Participants' Perception on the Feasibility of Concrete Reuse

The follow up question inquired that the participants share their reasoning, asking “Why, why not, or why maybe?”. Forty-eight participants elaborated; the highlights of their answers are outlined in Table 3.6.

Table 3.6 Analysis of Commentary on Feasibility of Using Reused Structural Concrete for New Construction

Key Concept	Number of Appearances	Context
Structural Integrity	28	<ul style="list-style-type: none"> ✓ Citing perception that feasibility seems possible (2) ✓ Stating that existing concrete components on the same site can be easily reused (e.g., abutments and piers) (1) ✓ Citing perception that it is possible to ensure quality (1) ✓ Citing that reused concrete may be stronger as concrete continues to strengthen year over year (1)
		<ul style="list-style-type: none"> - Openness to reusing concrete for new construction if it is structurally sound (9) <ul style="list-style-type: none"> - Free from chemical or other degradation (1) - "Acceptable condition" must be determined by Engineer with confidence and within a reasonable amount of time (1) - Openness to reusing concrete for new construction if has all the properties (4) - Openness if it meets the structural material requirements (2) - Openness if it meets long-term performance standards (2) - Openness if quality can be verified and approved (2) - Openness if it is determined to be structurally adequate (2) - Openness depending on age of reused concrete material (1) - Openness provided that original condition is well documented (1) - Openness if it meets durability requirements (1) - Openness if reused concrete can be easily disassembled, transportable, and worth reuse in a lifecycle perspective (1) - Citing the need to match surrounding materials (1) - Citing that it depends on in-situ conditions (1) - Citing that there may be more adoption if it is being "down-cycled" to another use that takes on less structural load (1)
		<ul style="list-style-type: none"> ✗ Concerns about deficiencies and capacity (2) ✗ Strength issues. May be used after compression check ✗ Concerns about limitations on determining capacities (1) ✗ Concerns about the existence of unknown deterioration (1) ✗ Citing that elements would be too deteriorated (e.g., bridges) (1) ✗ Citing that structures that are no longer required for service are too degraded to be used elsewhere ✗ Citing belief that reused concrete elements do not provide appropriate structural performance (1)
Design Constraints	12	<ul style="list-style-type: none"> - Openness to reusing concrete for new construction depending on the application and/or its suitability (5) <ul style="list-style-type: none"> - Citing that if they are used as blocks, they will have higher strength compared to regular concrete blocks - Citing that it may be possible for concrete masonry units - Openness to reusing concrete for new construction if it is the correct size (1) <ul style="list-style-type: none"> - Beneficial for some small sized projects (1) - Openness to reusing concrete for new construction depending on what type/form of reuse is used and how it will be incorporated into the design (1) <ul style="list-style-type: none"> - Adding that size of the project will have an impact on the feasibility of using reused concrete (1)
		<ul style="list-style-type: none"> ✗ Design challenges associated when using reused concrete in new construction (2) <ul style="list-style-type: none"> ✗ Record drawings unavailable (1) ✗ Scanning not thorough (1) ✗ Detailing for post fixed connections is difficult (1) ✗ Very rare to find suitable components (1) ✗ Experience of concrete reuse on retrofits of existing buildings but no openness to taking reused elements for new construction (1) ✗ Difficulties in implementation for high-rise buildings since the structure can have some shear critical zones (1)

Table 3.6 Continued

Other Limitations	10	<ul style="list-style-type: none"> ✗ Unfamiliarity with the requirements or concept of reusing concrete (3) ✗ Citing client limitation (2) <ul style="list-style-type: none"> ✗ Client may demand all new materials (1) ✗ Client's opinion on the feasibility of using reused concrete (1) ✗ Citing risk limitations (2) <ul style="list-style-type: none"> ✗ Discomfort with the risk of taking reused elements, would prefer designing new elements (1) ✗ Sensing too much risk involved with reusing concrete (1) ✗ Need for extensive quality control (1) ✗ Lack of knowledge (1) ✗ No access to proper information regarding the reuse of concrete except as a paving material (1) ✗ Expressing general uncertainties (1) ✗ Experience with reused structural steel but never with reused concrete (1)
Financial Considerations	8	<ul style="list-style-type: none"> ✓ Perception of economic benefits of saving money using reused materials (4) - Openness to concept if the cost of reused concrete is competitive (1) - Citing that the cost of the project will also have an impact on the feasibility of using reused concrete (1) ✗ Perception that it is likely not cost efficient (1) ✗ Perception that it is economically not feasible (1) ✗ Citing that there is added cost of processing the concrete which may or may not make it prohibitively expensive to reuse concrete as opposed to obtaining a new batch (1)
Environmental Sustainability	2	<ul style="list-style-type: none"> ✓ Stating that sustainability may be a selling feature for some clients (1) - Stating that environment should always be the second priority, after safety (1)

- ✓ Positive comments
- Neutral comments
- ✗ Negative comments

In the next question, the participants were asked to select possible reasons that would lead them to incorporate reused concrete components. Sixty-five professionals participated in this question. Figure 3.9 provides a summary of the breakdown of their reasons. Table 3.7 specifies responses from the “Other” category. From Figure 3.9, it is noted that 75% stated that the *Approval of an engineer* would lead them to make use of reused concrete, which is a substantial percentage of the professionals. This suggests that the verification from a trusted professional plays a critical role in the confidence of the reused concrete components. This is demonstrated further by the 58% who selected *Certificate of conformance*, suggesting that having a standardized approach to checking the condition of the components and providing certification is needed to support reuse of concrete. Also at 58% was *Financial discount*, implying that monetary gains are also fundamental in the decision-making process. Lastly, at 45%, *LEED credit* was in fourth place and with its score making up close to half of the survey participants from this group it also proves to be an important element to professionals in the industry.

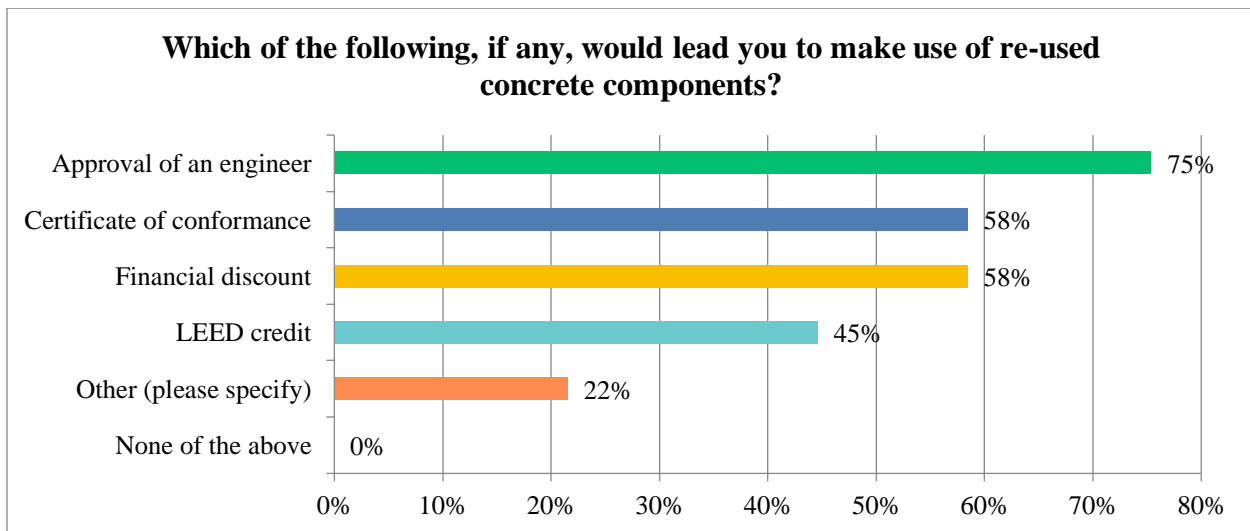

Figure 3.9 Breakdown of Reasons That Would Lead Professional to Reuse Concrete

In Table 3.7, the seventeen “Other” reasons specified by survey respondents are summarized. Many highlighted the need for technical specifications and design provisions to guide them in reusing concrete. Several noted the need for significant research findings, previous successful projects, and testing reports that would support the concept of reuse and establish it in the industry. Others emphasized the need for code approval and client approval to move forward with reuse.

Table 3.7 Outline of Other Reasons to Support Reuse of Concrete

Other
Approval by code
Significant research findings and research papers
Testing reports (such as strength test results and other tests to confirm that the properties are in line with contract requirements)
Existence of a standard
Benefits of using reused concrete must be measurable, consistent, and reliable
Advantages of reused concrete must significantly exceed corresponding metrics for conventional alternatives in order to offset any associated risks and the general unfamiliarity
Technical specifications should be convenient enough that concrete experts can trust the newly made samples and it should be economical compared to regular concrete products to attract potential business in market
Codes (such as CSA-S6 and NBC) establish clauses and chapters dedicated to reusable material and design provision to achieve such a level of reusable material
Sites may use it at their own discretion for non-structural applications
Client approval
Schedule allowance
Previous projects showing successful reuse of concrete
Designer has good understanding of the existing material/structure. There should be existing records. If not, ND tests will have to be done
Availability and contractor willingness to use a substitute to new concrete
Marketing it as a green solution
Precedent project. If the reused concrete was used somewhere already, having the ability to pay that site a visit to observe
Ability to show that the components are feasible when considering a lifecycle analysis of the structure

Participants were then asked to estimate how much the total design and construction cost of a reinforced concrete structure would increase, on average, if it were intentionally designed for disassembly so that its components could be reused in the future. Sixty responses were recorded; the average perceived overall price increase was estimated to be 35%. The distribution of their responses can see in Figure 3.10.

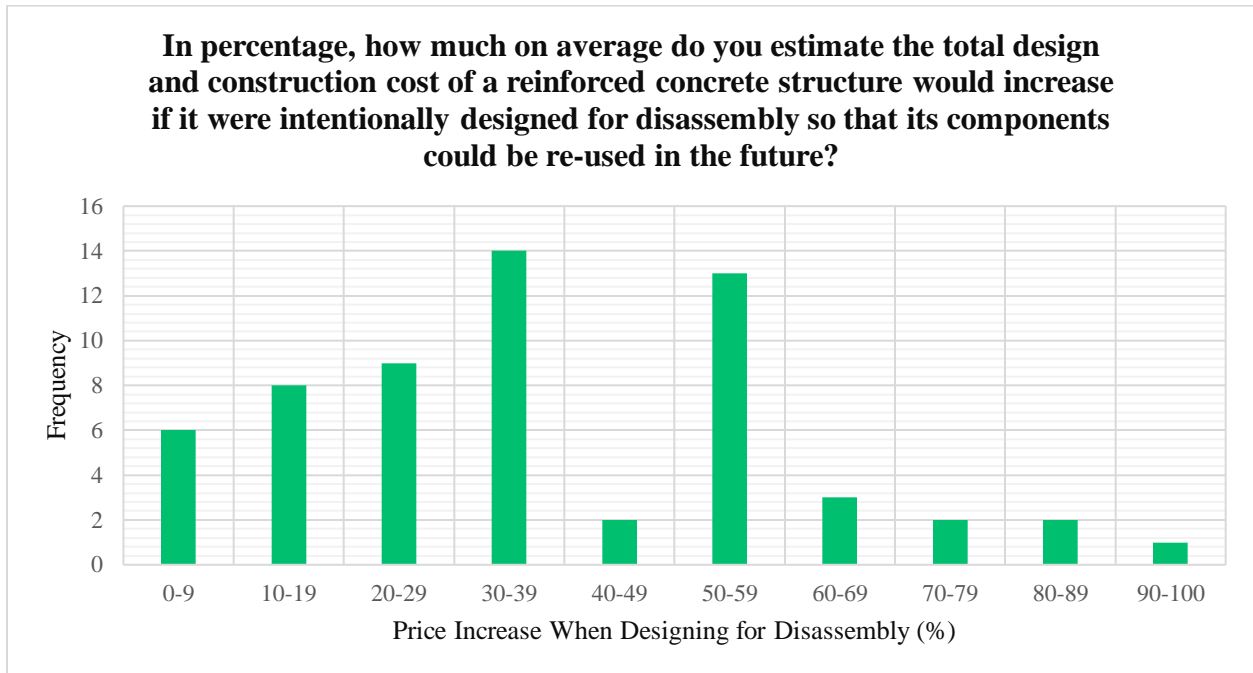

Figure 3.10 Distribution of Respondents' Estimates of Price Increases When Designing for Disassembly

Afterward, participants were asked a ranking question regarding the main obstacles preventing the reuse of concrete. Sixty responses were recorded and are summarized in Figure 3.11. *Technical challenges* was the top-ranked category with a score of 4.5. This was anticipated because as design engineers, consultants, and/or quality control engineers, the technical aspect is the heart of the work and as such, it would be a critical challenge. Tying for second/third place at a score of 4.2 were *Liability challenges* and *Logistical challenges*. The liability concerns were also expected as approving work that contains reused concrete components and taking professional responsibility for it will be daunting for professionals in this category. Logistical obstacles were also predicted as working with existing components will present new constraints for availability and quantity of materials.

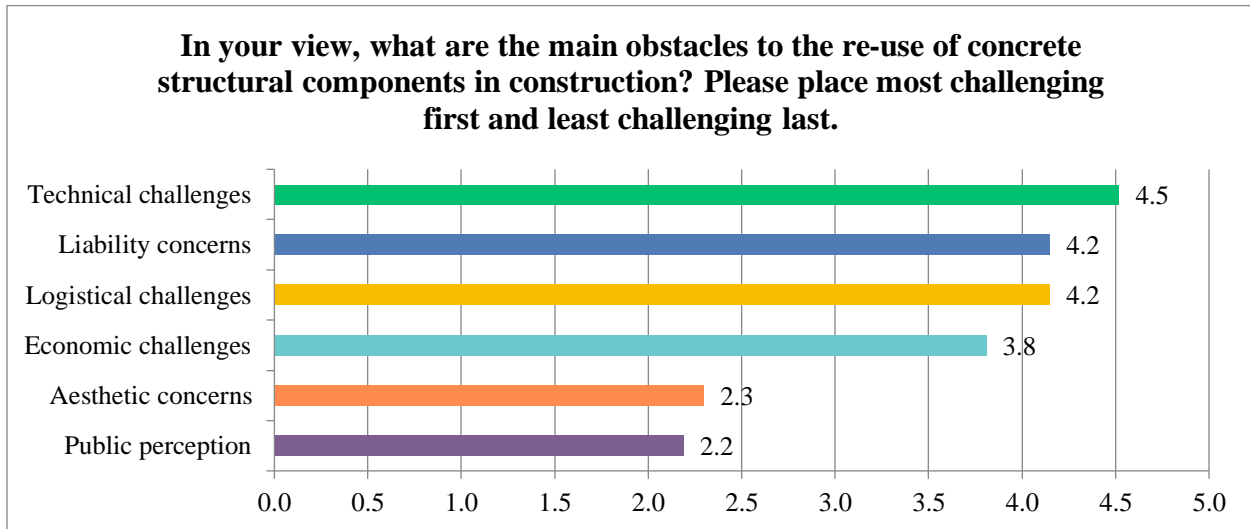

Figure 3.11 Ranking of Obstacles to Concrete Reuse

In the following question, respondents were invited to share any obstacles that were not highlighted in the previous question. Several participants shared their input as summarized in Table 3.8.

Table 3.8 Summary of Other Obstacles to Reuse of Concrete

Obstacles
How much does it cost financially and economically to take down concrete and prep it for reuse
Schedule. Reuse of concrete would require much more design time for investigation. Design schedules are already too short.
Testing reports (such as strength test results and other tests to confirm that the properties are in line with contract requirements)
To arrange enough machinery if crushing, pulverizing is required
Industry acceptance, from my brief experience within the construction industry it seems that new ideas take a long time to become normalized
Getting owner/client approval and whether the concrete is impacted or not (petrol stains, etc.)
Durability, can this component be expected to last 25, 50, 75 etc. and is it worth it in a lifecycle perspective if it needs earlier rehab/replacement

The next question asked participants to select perceived advantages of incorporating reused concrete components in construction projects. Sixty-five responses were received as summarized in Figure 3.12. The environmental benefits seem to be clear for the concrete professionals, with

the following three categories: *Reduced consumption of non-renewable resources*, *reduced greenhouse gases*, and *less burden on landfills* selected by 92%, 86%, and 86% of all respondents, respectively. No one selected that *There are no benefits* which is a positive sign that all the professionals polled believe that there is definitely something to gain from reusing concrete. One professional selected *Other* and specified that there might be a positive public outlook, particularly for culturally significant structures.

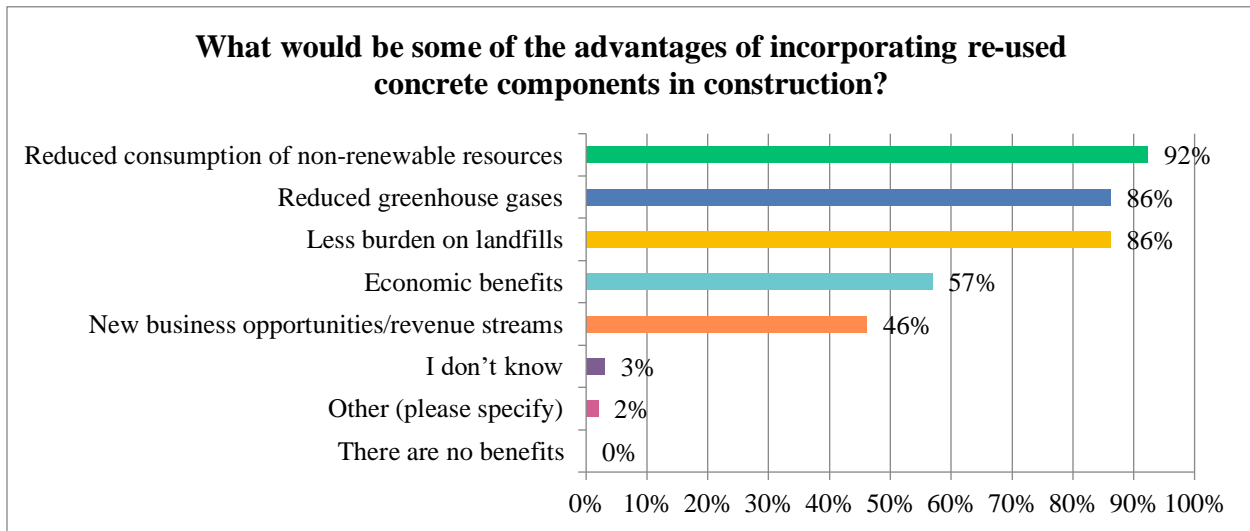

Figure 3.12 Breakdown of Advantages to Concrete Reuse

In the last question for this stream, the Concrete Professionals were asked what type, if any, of structural concrete applications would be most suitable for reuse. Sixty-five professionals ranked their answers from the most suitable to the least suitable. Figure 3.13 demonstrates the results. *Hydro poles and utilities* resulted in the highest suitability score of 3.5 while *Bridge infrastructure* had the lowest suitability score of 2.2. Meanwhile, *Concrete pipes and culverts* and *Building construction* tied with a score of 3.3 for structural application suitability.

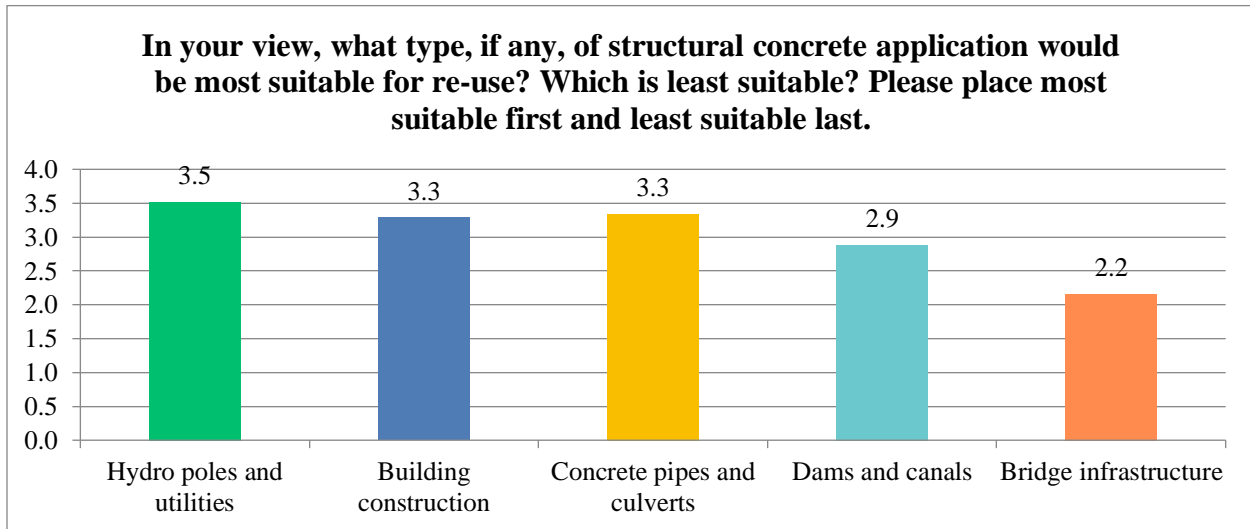

Figure 3.13 Ranking of Suitability of Structural Applications of Concrete Reuse

3.4.3 Concrete Structure Owner Stream: Results & Analysis

The Concrete Structure Owner stream includes those who identify as, for example, municipality, provincial or federal agency, and/or private owner. The first question in this stream divides the participants based on whether their establishment had any experience incorporating reclaimed concrete on a previous project. Eight participants answered this question with 3 (37%) having experience and 5 (63%) having no experience.

3.4.3.1 Experience with Reclaimed Concrete Subgroup

In this divergence of the Concrete Structure Owner stream, participants with experience incorporating reclaimed concrete were asked specific questions relating to their experience. When asked approximately what percentage of the projects undertaken last year incorporated reclaimed concrete, the average answer from 3 participants was 28%. Since the pool is limited, it is difficult to draw conclusive inferences; consequently, a qualitative approach is taken. The question follows up asking the participants to distinguish if the reclaimed concrete was reused or recycled and at what percentage. Figure 3.14 summarizes the breakdown of reclaimed concrete. Overall, there is a skew to the recycling category which is expected since recycling is more prevalent; however, that variation is small.

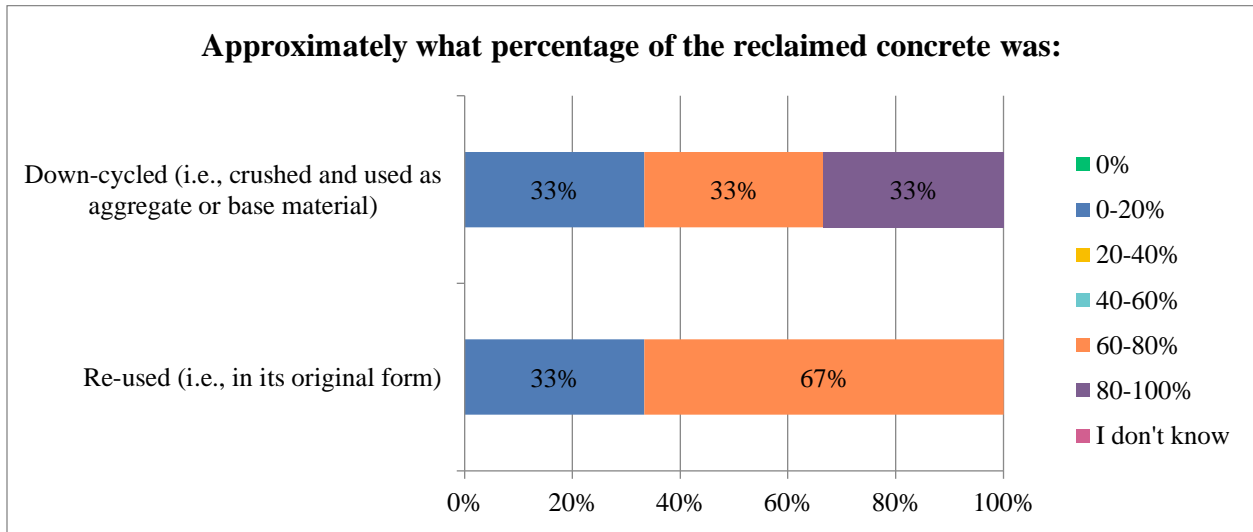

Figure 3.14 Breakdown of Reclaimed Concrete

When the 3 participants were asked what purpose(s) or application(s) they used their reclaimed concrete for, *Base material* and *Non-structural applications* each received 2 selections. *Commercial construction* received 1 selection. Similar to the previous stream, it appears that the reclaimed concrete does not play a critical structural role in its second life. The participants were then asked if they knew the original source of the reclaimed concrete. Two selected “Yes” and 1 selected “I don’t know”. One person further elaborated that the reclaimed material came from reused concrete capping components of a retaining wall.

In the next question, participants were asked if they would consider using reused concrete in its original form (not down-cycled as crushed aggregate or base material) for future projects. One respondent said “Yes” and 2 said “Maybe”. When asked on their reasoning, 2 responses were collected, both citing the cost savings. However, 1 participant did go on to say that in some cases it is more costly to clean and salvage than to purchase new.

3.4.3.2 No Experience with Reclaimed Concrete Subgroup

In this divergence of the Concrete Structure Owner stream, participants having no experience with reclaimed concrete were asked questions on their thoughts, perceptions, and considerations of the possibility of reusing reclaimed concrete in future projects. The first question asked if they would consider using reclaimed concrete (either reused or recycled) on a future project; 3 (75%) said

“Yes” and 1 (25%) said “Maybe”. This demonstrates a positive outlook to the concept of reusing concrete. When the participants were further asked about their reasoning, 3 offered comments. One owner said they would consider it but would have to familiarize themselves with case studies, pros/cons, etc. A second owner voiced that code compliance would be a key issue but as long as it meets applicable standards and specifications, they see no issue. The last respondent stated that they are supportive of the concept because it reduces construction waste from demolitions and the extensive use of natural aggregates.

The next question specifically asked about reclaimed concrete that is to be reused. Participants were asked if they would consider using reused concrete in its original form (not down-cycled as crushed aggregate or base material) for future projects. Interestingly, the percentages reversed with 1 (25%) saying “Yes” and 3 (75%) saying “Maybe”. This portrays a significant level of uncertainty in the concept of reused concrete from an owner’s perspective. Three participants offered input when asked why, why not, or why maybe. One participant repeated their previous point, that they would consider it but would have to familiarize themselves with cases studies, pros/cons, etc. Another stated that it would depend on the age of the material and its intended use. They said that some material in their assets are over 100 years old, making them less ideal for reuse/recycling. The last professional echoed this stating that it depends entirely on the state of the concrete and what they will be using it for.

3.4.3.3 Questions for Both

In this set of questions, both divergences of participants, those with experience with reclaimed concrete and those without experience with reclaimed concrete, were presented with the same questions. The questions focused on their perception of the concept of concrete reclamation, and more specifically, concrete reuse.

The next question asked participants to estimate how often a concrete structure is demolished before it is obsolete (i.e., before the end of its functional or structural service life). Seven owners answered this question with an average response of 54%. This suggests that those 54% of decommissioned structures can still offer value. The distribution of their responses is shown in Figure 3.15.

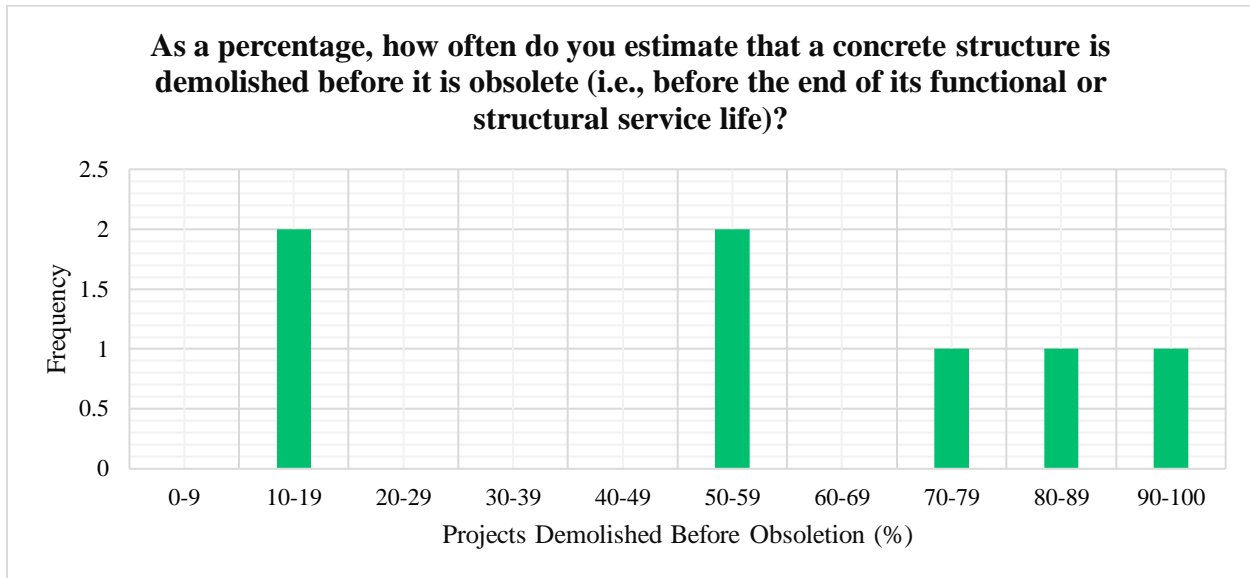

Figure 3.15 Distribution of Respondents’ Estimates of Structures Demolished Before Obsolescence

Participants were then asked if they consider reuse of structural concrete components for new construction projects to be feasible. There was a 50%-50% split with 3 saying “Yes” and 3 saying “No” – 1 person said “I don’t know”. Participants were then asked to rank what they viewed as the main obstacles to the reuse of concrete structural components in construction. The same top three challenges that the Concrete Professionals signaled also emerged as the top three challenges that the Concrete Structure Owners highlighted. However, the ranking of those three challenges was slightly different. Concrete structure Owners ranked *Liability* as their top obstacle with a score of 4.7 points. This makes sense since as owners do face potential legal risks and need to consider implications for insurance. *Technical challenges* came in second place with 4.3 points and *Logistical challenges* at third place with 4.1 points. Figure 3.16 below shows all the rankings. When asked further if there were other obstacles that they wished to include, participants stated awareness, quality assurance/quality control, and lack of specifications and governing body support as additional obstacles to consider.

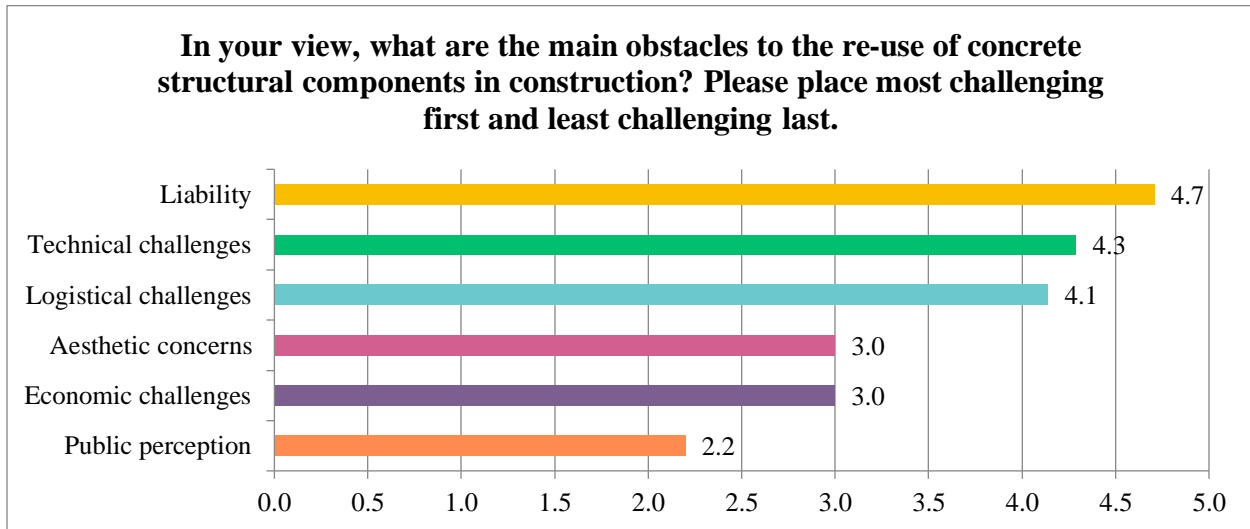

Figure 3.16 Ranking of Obstacles to Concrete Reuse

The participants were then asked to select from a list of potential advantages of incorporating reused concrete components in construction. Table 3.9 summarizes their perceptions. No one believed that that *There are no benefits* as this option had 0 checkmarks. The owners perceive a positive environmental impact with *Reduced consumption of non-renewable resources* receiving 6 votes as the top advantage and *Less burden on landfills* receiving 5 votes as the second-place advantage. They also see a financial gain as the *Economic benefits* box received 4 checkmarks putting it as the third-place advantage.

Table 3.9 Breakdown of Advantages of Including Reused Concrete for the Concrete Structure Owner Stream

What would be some of the advantages of incorporating re-used concrete components in construction?		
Answer Choices	Responses	
Reduced consumption of non-renewable resources	86%	6
Less burden on landfills	71%	5
Economic benefits	57%	4
Reduced greenhouse gases	43%	3
New business opportunities/revenue streams	29%	2
I don't know	14%	1
Other (please specify)	14%	1
There are no benefits	0%	0
	Answered	7

The last question for the Concrete Structure Owner stream was a multiple-choice question on their perception of the quality and performance of reused structural concrete components. Five options were presented; two had zero responses as no structure owner believed that reused concrete's quality and performance *cannot be determined* or that it is *likely to be similar to newly constructed components*. Two respondents believed that it *can be determined, but highly variable*. Another two believed that it is likely to be *marginally inferior to newly constructed components*. However, three structure owners believed that it would *likely be significantly inferior to newly constructed components*. The results are outlined in Figure 3.17.

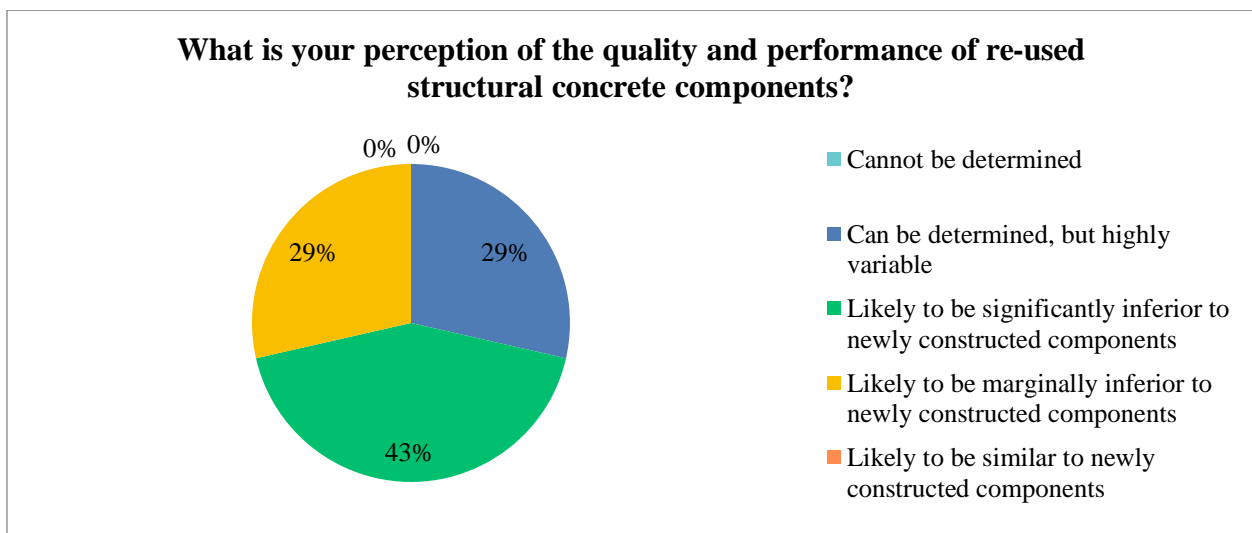

Figure 3.17 Perception of Quality and Performance of Reused Structural Concrete Components

3.4.4 Concrete Supplier Stream: Results & Analysis

The Concrete Supplier stream includes those who identify as, for example, precast or ready-mix suppliers. There were 10 questions for this stream and there were no divergences – all suppliers were asked to complete the same set of 10 questions. Six participants identified as a supplier with only two respondents providing answers to all 10 questions. A qualitative analysis of their responses is outlined below.

The first question asked the suppliers approximately how much concrete they deal with per year in metric tons. Three respondents answered this question giving an average of 78 metric tons (2 stated 100 metric tons and 1 stated 35 metric tons). When asked if they currently provide any

products or services that incorporate reclaimed concrete, 4 suppliers answered. Half said they have *No experience with reclaimed concrete*, one said they have *Experience with recycled concrete aggregates only*, and one said they have *Experience with both recycled and re-used concrete*. None had *Experience with re-used concrete only*. In the following question, suppliers were asked to specify how much of the concrete was reused and how much of it was downcycled. Three suppliers provided answers with none of them reusing or recycling concrete beyond 20%. This demonstrates a significant opportunity to do more in the areas of reuse and recycling. Figure 3.18 portrays the responses.

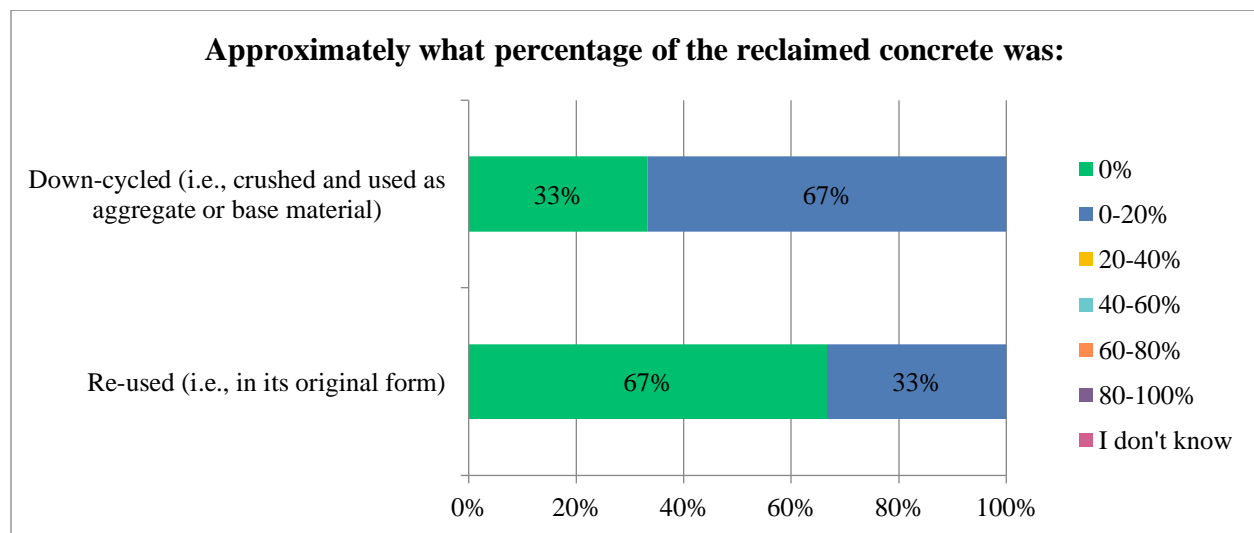

Figure 3.18 Breakdown of Reclaimed Concrete

Suppliers were then asked whether they would consider supplying reused concrete products if there was market interest from their clients and an accessible inventory. Three participants answered “Yes” and one said “No”. When they were asked to estimate what the average markdown in price would be for reused materials, three suppliers provided an answer and all said *No, there are no discounts provided*. When asked about their reasoning, two cited processing costs, explaining that the cost of reclaiming, inspecting, and storing reused product would not lower the cost over making it new, and one stated the fact that using environmentally friendly recycled materials could be marketed as a possible value-added product.

The following question asked participants to rank the main obstacles to the reuse of concrete structural components in construction. Like the Concrete Professionals and Concrete Structure

Owners, the Concrete Suppliers also had *Logistical challenges*, *Liability*, and *Technical challenges* as the top obstacles. However, the ranking of the top three differed. Undoubtedly for a supply company, *Logistical challenges* came in as the number one obstacle with 4.7 points. *Liability* and *Technical challenges* tied at 4.3 points for the number two main obstacles. Figure 3.19 provides the scores of other obstacles highlighted. When inquired further if there were other obstacles they wished to share, one person stated the challenges of reclaiming product without damage, and another cited the difficulty of maintaining a consistent source of the products to ensure quality and availability.

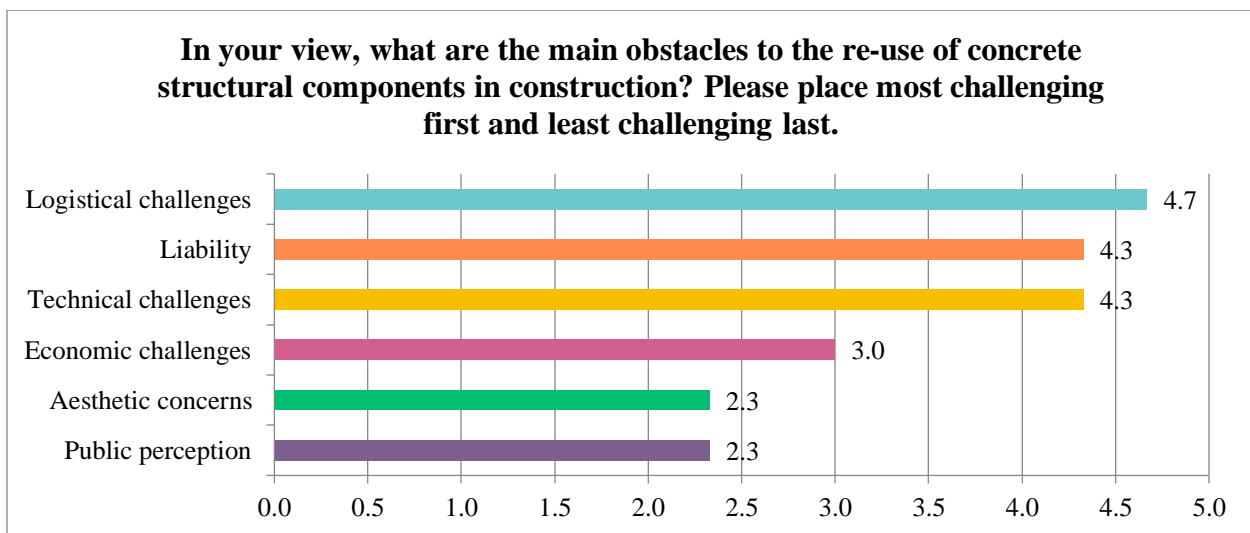

Figure 3.19 Ranking of Obstacles to Concrete Reuse

The next question asked suppliers about some of the advantages of incorporating reused concrete components in construction. Table 3.10 summarizes their responses. Looking at the data, it is clear that the suppliers are all well aware of the environmental advantages the reuse of concrete provides. 25% also see some financial and business benefits.

Table 3.10 Breakdown of Advantages of Including Reused Concrete for the Supplier Stream

What would be some of the advantages of incorporating re-used concrete components in construction?		
Answer Choices	Responses	
Reduced consumption of non-renewable resources	100%	4
Reduced greenhouse gases	75%	3
Less burden on landfills	50%	2
Economic benefits	25%	1
New business opportunities/revenue streams	25%	1
There are no benefits	0%	0
Other (please specify)	0%	0
	Answered	4

The last question the suppliers were asked was regarding their perception of the quality and performance of reused structural concrete components. Three (75%) stated that it *Can be determined, but highly variable* and one (25%) stated that they are *Likely to be significantly inferior to newly constructed components*.

3.4.5 Concrete Contractor Stream: Results & Analysis

The Concrete Contractor stream includes those who identify as, for example, builders or demolishers. There were 10 questions for this stream and there were no divergences – all contractors were asked to complete the same set of 10 questions. Thirteen participants self-identified as a contractor with seven providing answers to all 10 questions. A qualitative analysis of their responses is outlined below.

The first question asked the contractors to quantify how much concrete is reclaimed by their company per year in metric tons. The average value from seven participants was 36 metric tons of reclaimed concrete per company. The distribution of their responses is outlined in Figure 3.20.

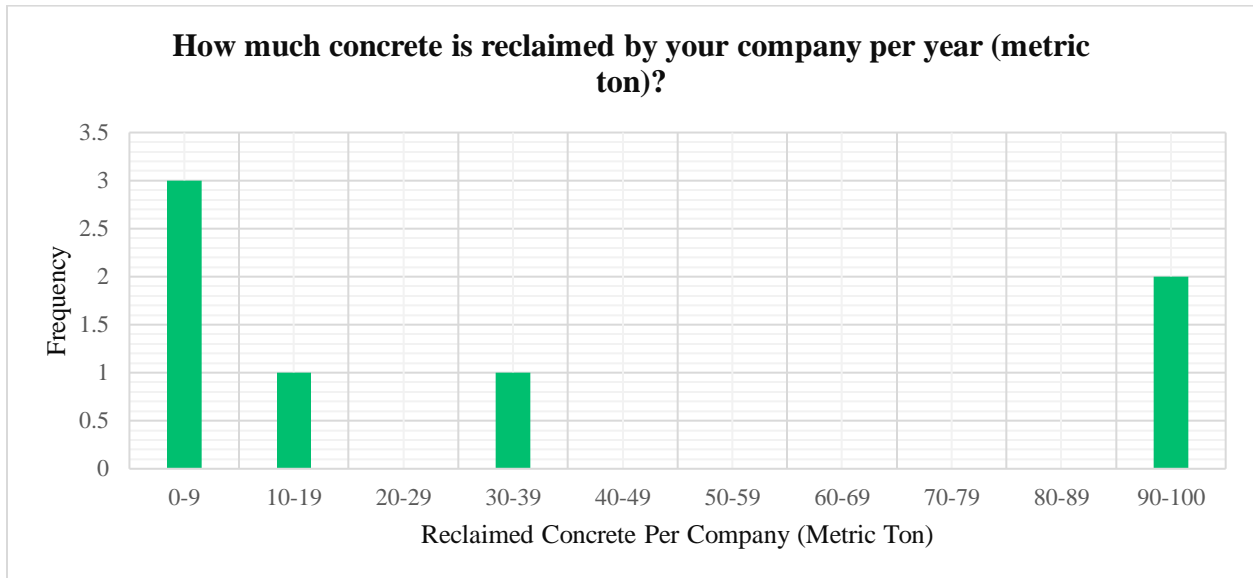

Figure 3.20 Distribution of Respondents' Concrete Reclamation Efforts

This question was followed by asking the participants to provide a breakdown of the end use of the concrete recovered from their job sites. The responses are summarized in Figure 3.21. Only one participant elaborated on their “Other” entry for which they stated, “Waste Disposal”. None of the respondents indicated a reuse level above 20%, while 28% of respondents recycled more than 20% of the recovered concrete. All of the respondents also indicated that at least some of their recovered concrete ends up in landfills.

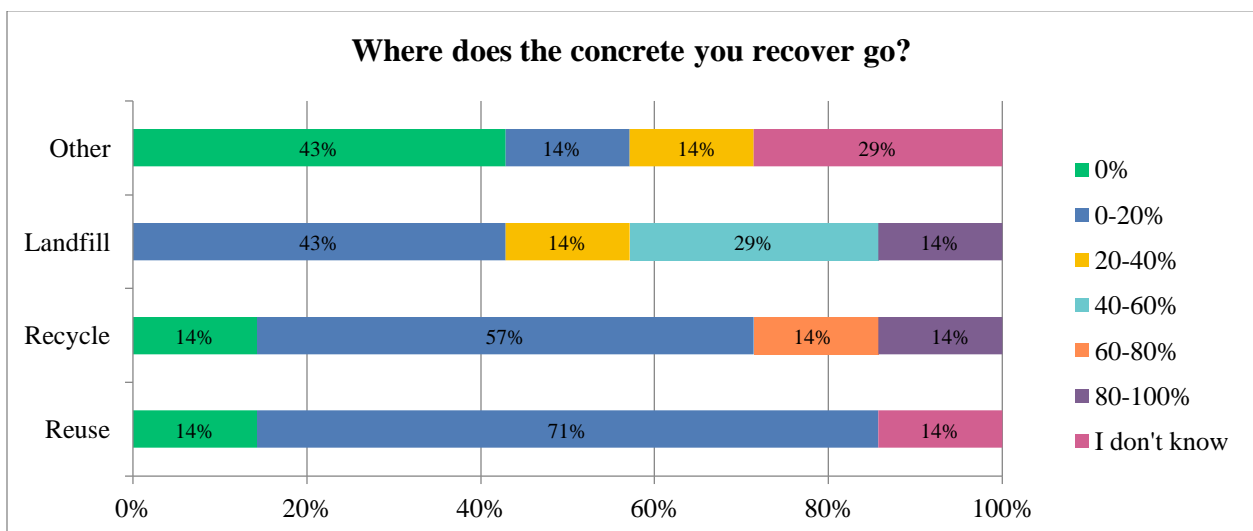

Figure 3.21 Breakdown of Concrete Recovered

Subsequently, the contractors were asked about the purpose(s) or application(s) of concrete that was reclaimed for other uses. Their answers are outlined in Figure 3.12. As noted in the results from previous streams, it appears that the reclaimed concrete materials take a non-structural role post-recovery. *Base material* was the most common response and *Non-structural applications* came in second place. The *Other* category was not specified by the participant.

Table 3.11 Purposes or Applications of Reused Concrete

For what purpose(s) or application(s) did you use reclaimed concrete? Check all that apply:		
Answer Choices	Responses	
Base material	57%	4
Non-structural applications (e.g., drainage)	43%	3
Public infrastructure	29%	2
Aggregate in concrete	14%	1
Commercial construction (e.g., office space or warehouse)	14%	1
Residential construction (e.g., apartment building)	14%	1
Other (please specify)	14%	1
I don't know	0%	0
	Answered	7

The ensuing question aimed to gain insight into the customers that the contractors served. The question asked the contractors to rank their most frequent first and their least frequent customers last. Figure 3.22 shows the results of the responses from seven contractors. The most popular consumer was *Government establishments* with a score of 4.5. In second place was *Large-scale projects* at 3.5 followed by *Private sector companies* at 3.4. The *Other* category was not specified by those who selected it.

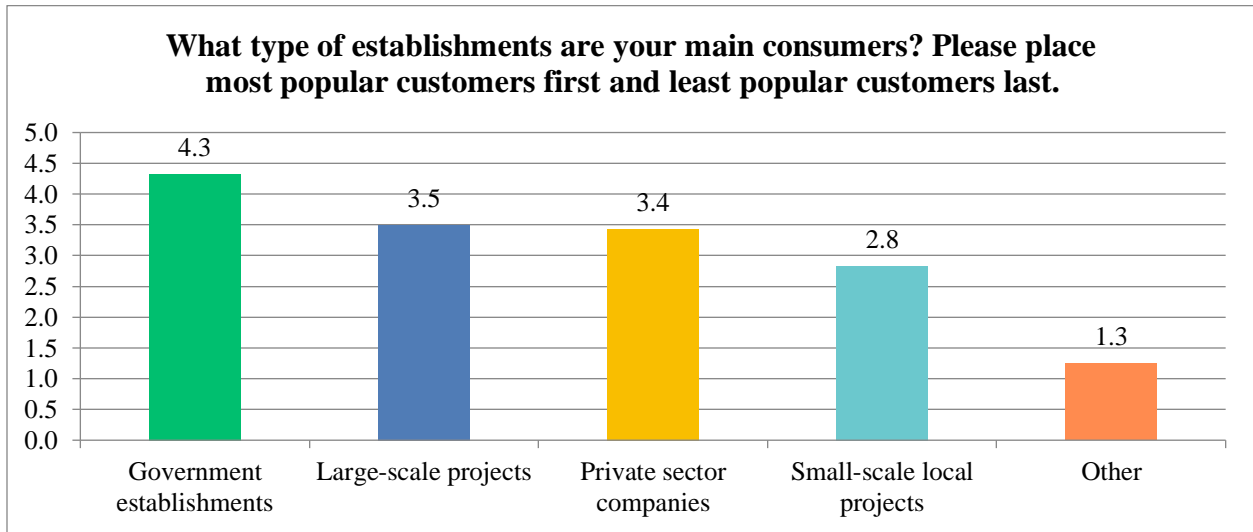

Figure 3.22 Customers of Contracting Companies

The participants were then asked what percentage of concrete components in a decommissioned structure are likely to be salvageable with minimal processing. Three contractors said 0-20%, two contractors said 20-40%, one contractor said 60-80%, and one said “I don’t know”. Afterwards, contractors were asked if there would be an additional cost associated with dismantling (i.e., disassembling) versus demolishing (i.e., destroying). Figure 3.23 shows the responses received with a clear consensus that there is certainly an additional cost to be expected with taking apart infrastructure as opposed to destroying it.

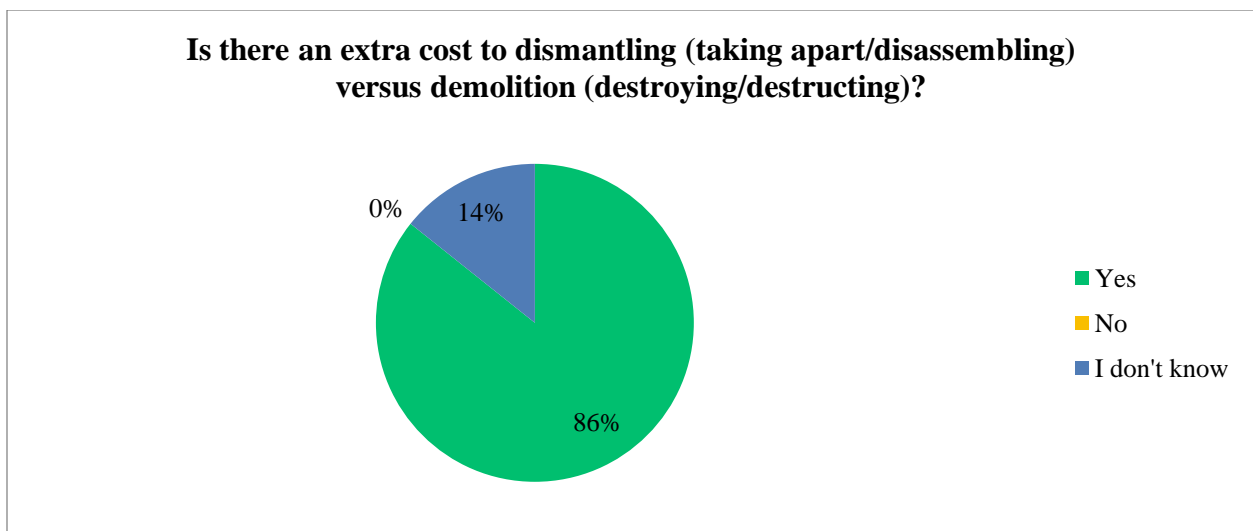

Figure 3.23 Dismantling Versus Demolition Cost

The following question asked the contractors to provide additional comments on the challenges associated with dismantling versus demolition of concrete structures. The six comments received are outlined in Table 3.12. Three common challenges emerge from their responses regarding dismantling:

- More time consuming (mentioned in 4/6 responses)
- More costly (mentioned in 4/6 responses)
- More labour intensive (mentioned in 3/6 responses)

Table 3.12 Challenges Association of Disassembly of Concrete Structures

What challenges are associated with dismantling versus demolition of concrete structures?
Labour intensive, must replace some of what is being dismantled as not all materials will be reclaimable
The additional time to ensure the material is not damaged during the dismantling. Also, additional costs to determine if the dismantled concrete material is suitable for re-use and provides the same strengths characteristics as new concrete
Cost
Dismantling requires design analysis, and it is more time consuming than demolition
It takes a lot more man hours and is costly. Demolition/destruction is all done with heavy equipment. Dismantling is generally done with smaller equipment and more men
Dismantling of existing concrete will also require re-testing to ensure conformance of specs. Dismantling will also require additional labour hours and equipment rather than demolition. (i.e., extra cost, and longer time required). The dismantled concrete may turn out to be unsuitable and not conform to stringent project specifications. However, the dismantled concrete can be graded to be used as fill (save on back-fill material cost)

Then, the contractors were asked about some of their perceived advantages of incorporating reused concrete components in construction (Table 3.13). The participants seem to be clear on the environmental benefits of reuse, however, the financial benefits are less pronounced. The answers were unanimous in that there do exist benefits to the reuse of concrete.

Table 3.13 Breakdown of Advantages of Including Reused Concrete for the Contractor Stream

What would be some of the advantages of incorporating re-used concrete components in construction?		
Answer Choices	Responses	
Less burden on landfills	86%	6
Reduced consumption of non-renewable resources	71%	5
Reduced greenhouse gases	71%	5
Economic benefits	57%	4
New business opportunities/revenue streams	29%	2
There are no benefits	0%	0
I don't know	0%	0
	Answered	7

Next, the contractors were asked if they know of any projects which feature reuse of concrete components. Two answered “Yes” and five stated “No”. One person who stated “Yes” shared that the current project they are working on “re-uses crushed concrete as granular B type 1 materials for road base as it meets the B1 gradation specifications” which is really an example of recycling – and not reuse – of concrete.

3.4.6 Additional Comments and Feedback

In this component of the survey, participants from all streams were presented with the optional opportunity to provide additional comments and feedback for the research. Twenty-three responses were gathered. Most of the commentators sent their good wishes for the future of this research with some stating that this topic should be addressed at a larger scale and that they believe the future of construction materials needs to stem from reclaimed materials. There were several who provided further insight. One person working in the concrete pipe industry explained that work is often done with little care and incurs lots of damage hinting that material recovery is unlikely. Another person said that some articles or a subsection in the NBCC (and CHBDC), as well as corresponding provincial building codes, should be added to introduce the idea, make recommendations, and pave the way for future use of the reclaimed building components.

One comment emphasized that while reusable concrete might be a very good option, this will not be the case before it becomes a clear science. They echoed the liability concerns stating that no contractors nor engineers would want to take on the risk of using old, recycled concrete on their projects. They further explained that insurance is expensive in the construction and design practice, hence, everyone is afraid to go wrong. Another professional stated the need for proper procedures to be prepared and submitted to the engineering and construction crews about concrete reclamation explaining that often when concrete is poured on site, any excess is simply put into waste disposal bins for hauling off site. Therefore, reuse of existing concrete can be an economic and environmental benefit only if proper knowledge is shared with those that actually make the calls on site (i.e., site superintendents).

Another comment expressed positivity by stating that they think structurally speaking, it is not difficult to assess recycled/reused components. However, it is the durability and life cycle side that matters and that can be ambiguous, explaining that if it is demonstrated that reused components can be financially superior over a 75-year design life when considering rehabilitation, maintenance, and eventual replacement, then it would be a very interesting prospect to consider. The participant later expressed questions about the availability of components and where they would be stored, as well as whether there will be a need to increase warranties or guarantees on these products, and whether there would be enough of them to meet the needs of the project. Lastly, for design purposes, it was asked whether the geometry of the components must suit the site, or whether the site can potentially be modified to suit the geometry of the components.

3.5 Key Findings

This survey study presented several significant outcomes that should be highlighted. They are expressed below:

- Unanimously across all four streams, all of the participants agreed that there are important benefits to incorporating reused concrete components in construction
- The environmental advantages of concrete reuse appear very clear to all four streams; however, financial benefits, while perceived by some, are less pronounced

- The same three main obstacles to concrete reuse always emerged across the three streams where this question was asked: technical challenges, logistical challenges, and liability challenges. However, the order was different depending on the stream:
 - For the Concrete Professional stream, technical challenges were most important
 - For the Concrete Owner stream, liability concerns were most important
 - For the Suppliers stream, logistical challenges were most important
- There is a significant opportunity to do more in the areas of reclaiming concrete to be reused and/or recycled as recovered concrete generally ends up in landfills
- Reclaimed materials are often recycled – not reused – and are not currently fully trusted by Concrete Professionals to be used for structural applications
- All contractors screened – except those who stated they don't know – assert that there is an extra cost to dismantling versus demolishing as it more time consuming and labour intensive
- There is positive interest in the concept of concrete reuse; however, there is clear uncertainty on how to approach it and thus there is a need for guidance and pilot studies
- There needs to be incentives to promote concrete reuse in the industry. This could be financial in the form of discounts and/or governmental support. Another would be through providing LEED credits and/or credits through other sustainability metrics
- A comprehensive supply chain for reused concrete needs to exist before reuse can be considered at scale. It would be extremely helpful if the reused concrete components have an engineer's approval and come with a Certificate of Conformance
- A successful approach to concrete reuse is one that involves all parties involved on- and off-site, including engineers, consultants, contractors, suppliers, site administrators, and of course, the client
- The future of construction materials may need to stem from reclaimed materials as natural resources become limited; as such, more awareness on the importance of sustainability in construction needs to be shared to those in the industry and beyond.

4 Chapter 4: City of Ottawa Bridge Case Study

4.1 Background

To further explore some of the challenges associated with the reuse of concrete structural components, two case studies are presented in this thesis. Two existing Ottawa structures—one bridge and one building—were selected and hypothetical scenarios for deconstruction and reuse are introduced. The main purpose of this exercise is to identify opportunities and challenges related to technical design aspects; hence, other issues related to cost, logistics, life cycle assessment, and liability concerns are not addressed in this research and are recommended for future work. Furthermore, it is important to mention that the following deconstruction plans, and structural designs are conceptual only and are not intended to consider all potential construction details and load cases which are outside the scope of this thesis. Rather, these case studies are intended to serve as a preliminary step towards evaluating the feasibility of structural concrete reuse from an engineering perspective. It is also worth noting that an ideal reuse scenario begins at the design (or pre-design) stage so that the eventual disassembly and repurposing of the structure are considered from the outset (i.e., cradle to cradle design); since this is not currently common practice, the following case studies consider the more daunting task of deconstructing existing structures that were not designed for reuse and were constructed monolithically. This process is much less efficient but is a necessary starting point in the current paradigm.

The first case study is based on the bridge structures comprising the Ottawa Regional Road 47 Overpass over the Ottawa Regional Road 174. Ottawa Regional Road 47 is also known as Tenth Line Road whereas Ottawa Regional Road 174 is also commonly referred to as Highway 174 or the Queensway. The five-span prestressed concrete bridge supports three northbound lanes and two southbound lanes. The twin-bridge structure is comprised of a continuous concrete deck supported by 70 CPCI 1600 girders. Only the main superstructure components are considered in this case study, although it is worth mentioning that reuse of bridge substructures and foundation elements present significant cost savings and environmental benefits and has received increased attention in recent years (Agrawal et al., 2018). The bridge is managed by the Asset Managing

Branch of the Planning, Infrastructure and Economic Development Department at the City of Ottawa. Drawings were obtained from the city's Information Centre.

This Ottawa Road 47 overpass was selected primarily due to two reasons. It is an I-girder bridge with regular geometry; consequently, it is simpler to work with and facilitates the demonstration of the reuse concept. The bridge is also multi-spanned, thus providing a bigger inventory of members to reuse. This is important as it not only allows for flexibility in the new design, but it also permits the selection of the best elements of the existing bridge to be reused from the inventory bank in the case that some components are deteriorating or damaged.

4.2 Bridge Description

4.2.1 Location

The overpass is located in Ottawa's east end district (Orléans). It is approximately two kilometres from the Place d'Orléans Shopping Centre, the suburb's main shopping mall, and approximately 20 km from the city's downtown core. Figure 4.1 shows the view of the overpass from Google Maps.



Figure 4.1 Tenth Line Road Overpass (Google Maps)

4.2.2 Year Built and Usage

The drawing records were dated in November 1992. The design standards were based on the Ontario Highway Bridge Design Code (OHBDC) 1983 with a Class A designation. Although recent inspection documents are not available, the bridge appears to be in good condition with no evident signs of damage or deterioration. Figure 4.2 shows the underside view of the bridge; more pictures can be found in Appendix B.



Figure 4.2 Distant Underside View of Overpass Showing Full Width (Google Maps)

4.3 Existing Bridge

4.3.1 View of Existing Bridge

Figure 4.3, Figure 4.4, and Figure 4.5 present the plan view, elevation view, and cross-sectional view of the current bridge. In Figure 4.3, the plan view of the bridge shows its south bound lanes (SBL) and north bound lanes (NBL). In Figure 4.4, the elevation view of the bridge shows the bridge's five spans with a total length of 189.5 metres; the three middle spans are 36 metres each and the end spans are 33 metres each. In Figure 4.5, the cross-sectional view of the bridge shows a set of 14 CPCI 1600 girders with a centre-to-centre spacing of 2.1 m where each set of seven girders is supported by the concrete piers. There are a total of eight piers for the five-span bridge

with four supporting SBL girders and four supporting NBL girders. The 70 prestressed precast girders – with 14 per span – are supported by bearings at each pier with cast-in-place end diaphragms to provide continuity between spans. There is an island that runs down the middle of the bridge and two pedestrian sidewalks on opposite ends of the bridge roadway. Barrier walls with railings are installed at either side of the bridge.

4.3.2 Disassembly Plan of Existing Bridge

The deconstruction process is one of the most critical aspects of this case study. The objective is to carefully disassemble the superstructure elements of the bridge without significantly infringing on their structural integrity, while also limiting labour and processing requirements. This is imperative since these components are intended to be reused for the design of a new hypothetical bridge presented in the next sections. As noted earlier, in accordance with current practice the bridge under consideration was not designed for disassembly, and hence the deconstruction process is evidently more difficult and less efficient than desired; ideally, by promoting reuse of concrete in practice and designing new structures with disassembly in mind, more optimal approaches can be developed.

4.3.2.1 Girders

The cast-in-place deck slab and precast prestressed girders were designed and built as a composite section. As a result, saw cutting is required to separate the individual girders from the deck. Three potential cutting schemes are demonstrated in Figure 4.6 (a), (b), and (c). In Figure 4.6 (a), the girder is fully separated from the bridge deck by cutting horizontally through the slab-girder interface, a process which is impractical and potentially not feasible. In Figure 4.6 (b), the girder is extracted by making vertical saw cuts through the deck slab adjacent to the top girder flange, leaving a portion of the deck slab connected to the girder. In Figure 4.6 (c), the girder along with an extended portion of the deck is extracted using vertical saw cuts to effectively form a modified bulb-tee section geometry. A summary of the advantages and disadvantages associated with each option is presented in Table 4.1. Upon careful consideration, Option 2 (presented in Figure 4.6 (b)) was selected as the most practical choice for transportation and storage with the highest potential in terms of reassembly (i.e., connection).

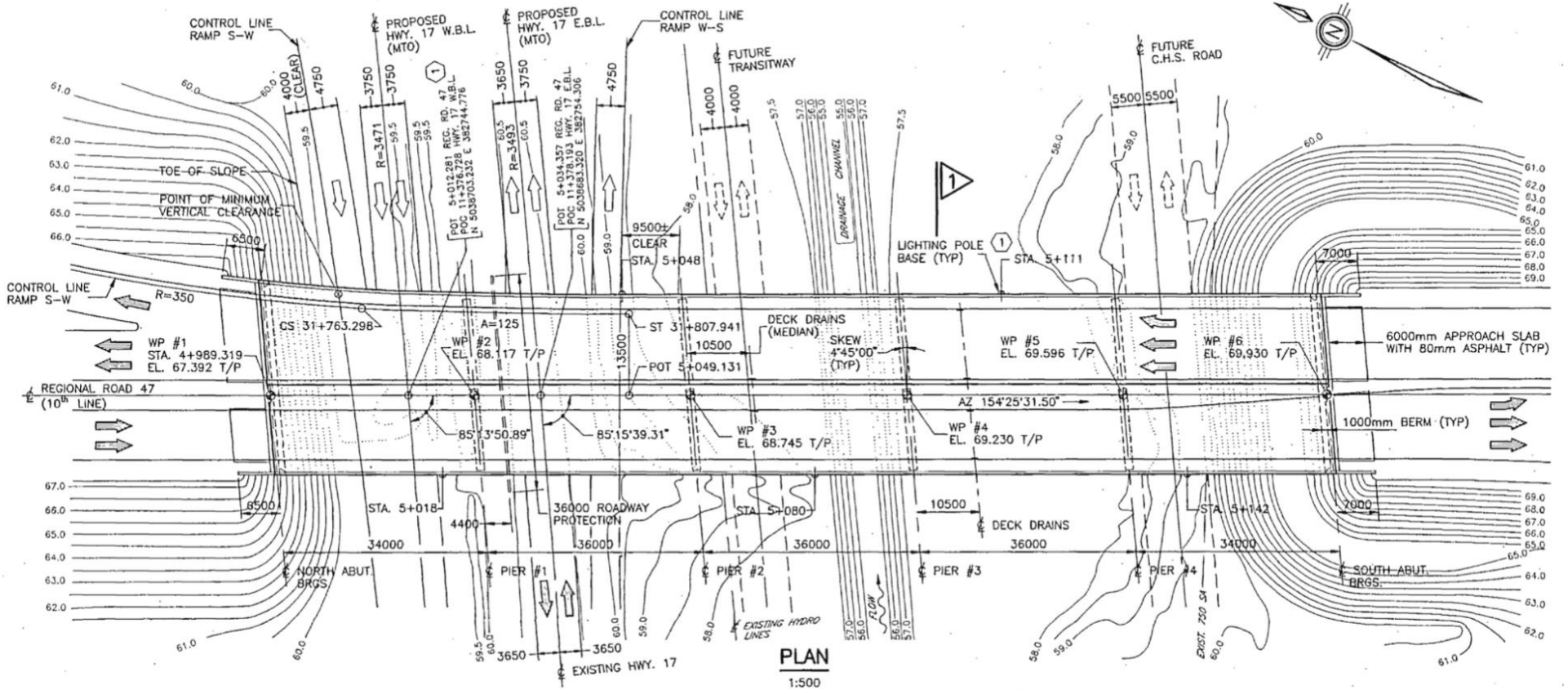

Figure 4.3 Plan View of Bridge

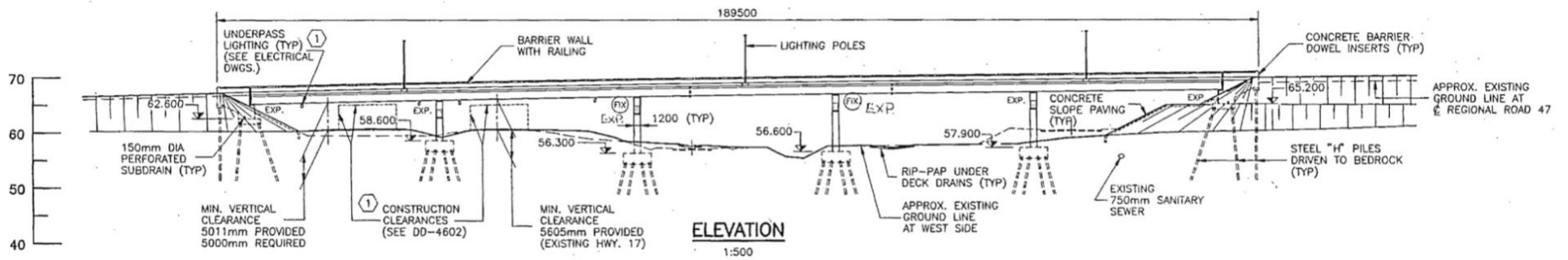

Figure 4.4 Elevation View of Bridge

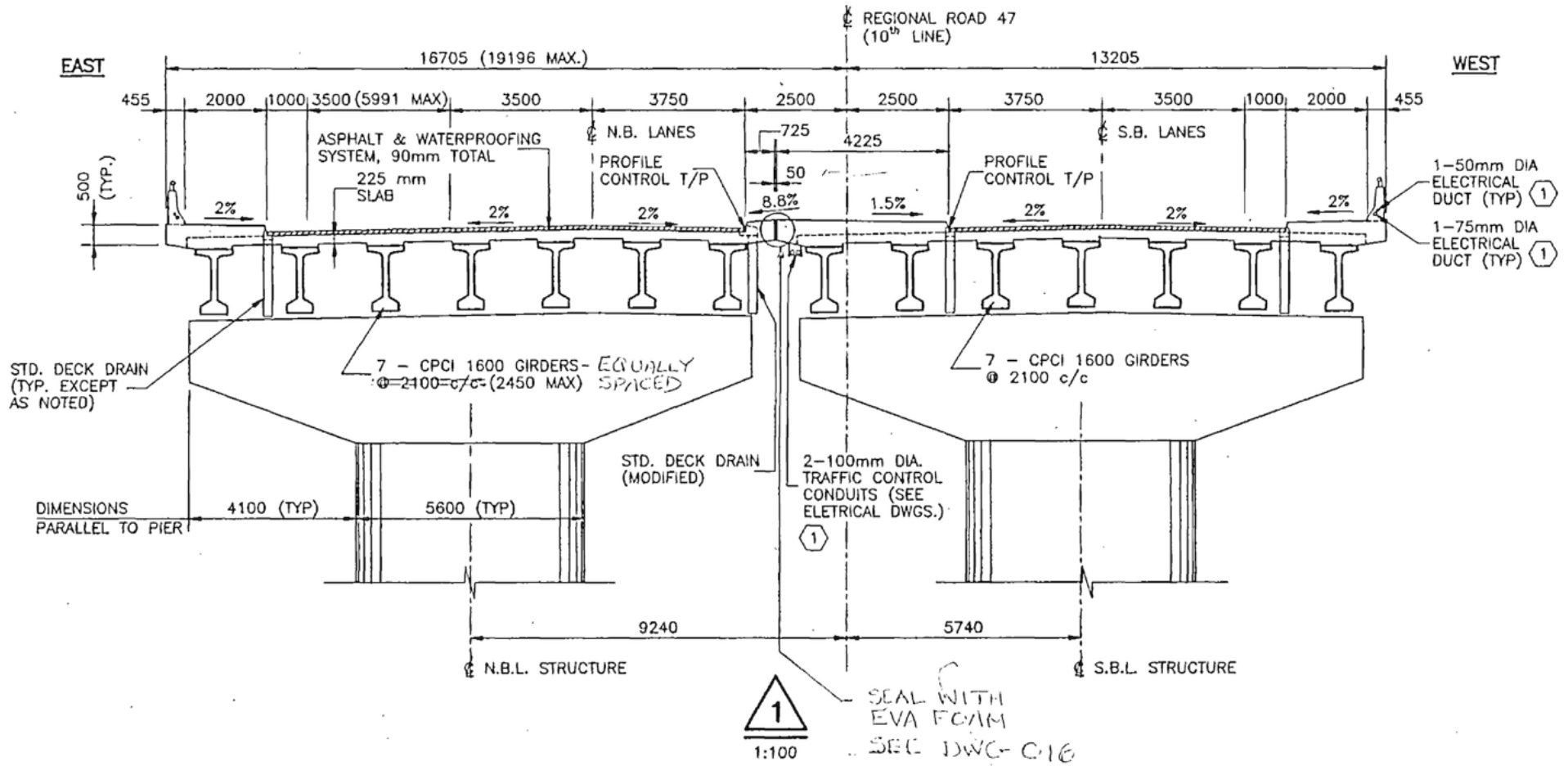

Figure 4.5 Cross-Sectional View of Bridge

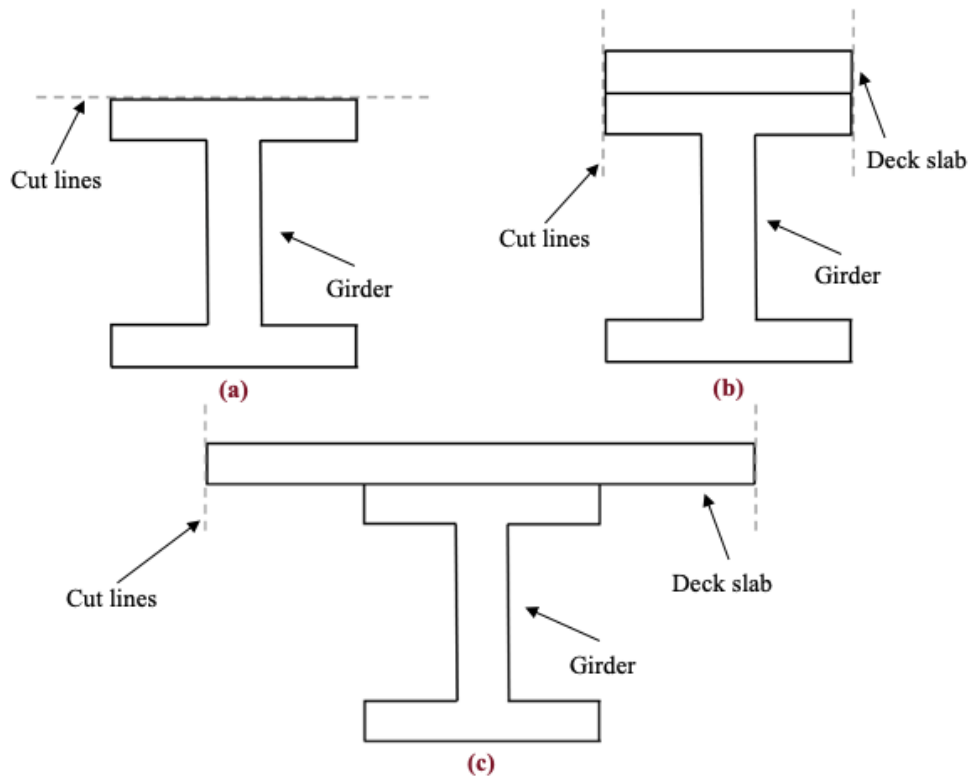

Figure 4.6 (a) Cut option 1 (b) Cut option 2 and (c) Cut option 3

Table 4.1 Summary of Advantages and Disadvantages Associated with Each Option

Advantages	Disadvantages
Cut Option 1	
<ul style="list-style-type: none"> • Easiest to transport • Maintains original section geometry of slab and girder 	<ul style="list-style-type: none"> • Difficult or impossible to perform the cut on site; must completely separate slab from girder
Cut Option 2	
<ul style="list-style-type: none"> • Easy to transport • Easy to perform the cut 	<ul style="list-style-type: none"> • Modifies geometry of slab and girder • Requires more complex connection for reassembly

Table 4.1 Continued

Cut Option 3	
<ul style="list-style-type: none"> • Easy to perform the cut • Placing the bulb-tee sections side by side can approximately reproduce the original bridge cross-section 	<ul style="list-style-type: none"> • Connection during reassembly will be at or near the slab midspan (in the transverse direction) • Hardest to transport due to the slab extension on either side

4.3.2.2 Deck Slab

One of the most important considerations when working with the deck slab is sawing it into manageable pieces that a) will minimally impact the structural integrity of each new piece and b) can be conveniently transported to the new site of construction. Since each girder extracted will take with it the portion of slab directly on top of it (Section 4.3.2.1), the remaining slab span length will be equal to the clear distance between adjacent girder flanges. The cross-sectional view of the bridge, as seen in Figure 4.5, shows a total bridge width of 29.0 m with the railing widths removed. Considering that the CPCI 1600 girders have a top flange width of 0.9 m and are spaced 2.1 m centre-to-centre, the clear span of the slabs is 1.2 m. Therefore, there will be 13 slab strips between the 14 girders, however, only 12 will be usable since the middle section connecting the SBL and NBL is linked using foam joint seal. In total, with 12 slab strips per span and five spans, 60 rectangular slab sections are potentially available for reuse. Each slab section is 1.2 m wide but will vary in length depending on the bridge span length which ranges from 33 m to 36 m. These can be cut further into shorter rectangular segments to make them more manageable for lifting and transportation if necessary.

4.3.3 Inventory of Reusable Bridge Components

For this case study, only the superstructure components were considered. Those include the girders, deck slab, and barrier walls with railings; as previously noted, reuse of bridge foundations is increasingly being considered and practiced in various jurisdictions but is not the focus of this study. Table 4.2 below shows the summary of available inventory following the deconstruction process. As such, the geometry of certain components has been modified to show what the



components will be post disassembly. The extracted girders now include a portion of the deck slab above it which becomes part of the top flange in the modified geometry. Each girder contains 46 prestressing strands made from low-relaxation seven wire strand, size designation 13, and grade 1860. The class of concrete for the bridge is 30 MPa, except for the prestressed girders where it is 40 MPa. The reinforcing steel is grade 400.

4.4 Repurposed Bridge

4.4.1 Proposed Geometry

For the purpose of this case study, it is assumed that the components of the decommissioned bridge are intended to be reused for a hypothetical three-span bridge structure having similar span lengths as the original bridge. The geometry of the reconstructed bridge has been determined arbitrarily in order to conceptually demonstrate the flexibility of the proposed methodology, as well as potential challenges and limitations. The proposed design consists of twin bridges that are identical in design with their girders simply supported. One bridge shall serve the northbound traffic while the other serves the southbound traffic. Each bridge will be 106 m long with the end spans being 36 m each and the central span being 34 m. The width of each bridge structure will be 13.91 m with two traffic lanes, a bike lane, and two sidewalks. The cross-sectional view and the plan view of the proposed bridge can be seen in Figure 4.7 and Figure 4.8. Note that these figures showcase one of the twin bridges as the other will be identical.

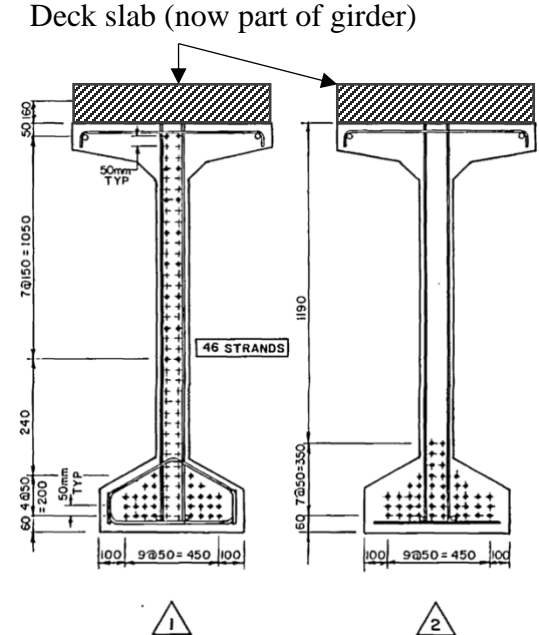
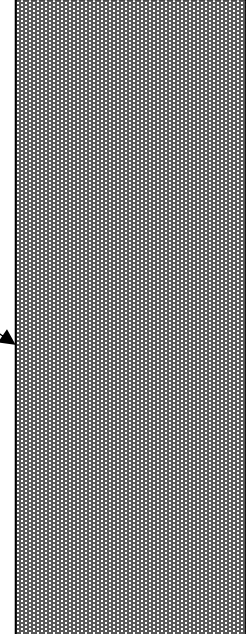
Table 4.2 Superstructure Elements of Bridge

Element	Quantity	Details
<p>Girders</p>	<p>70 CPCI 1600</p> <p>42 at 35.8 m length 28 are 34.225 m to 34.464 m length</p>	<p>Deck slab (now part of girder)</p>  <p>1: endspan 2: midspan</p>
<p>Deck Slabs</p>	<p>60 sections</p> <p>0.225 m depth 1.2 m width 24 at 33 m length 36 at 36 m length</p>	<p>Slab section</p> 
<p>Barrier Walls with Railings</p>	<p>10 segments</p> <p>6 at 36 m length 4 at 33 m length</p>	

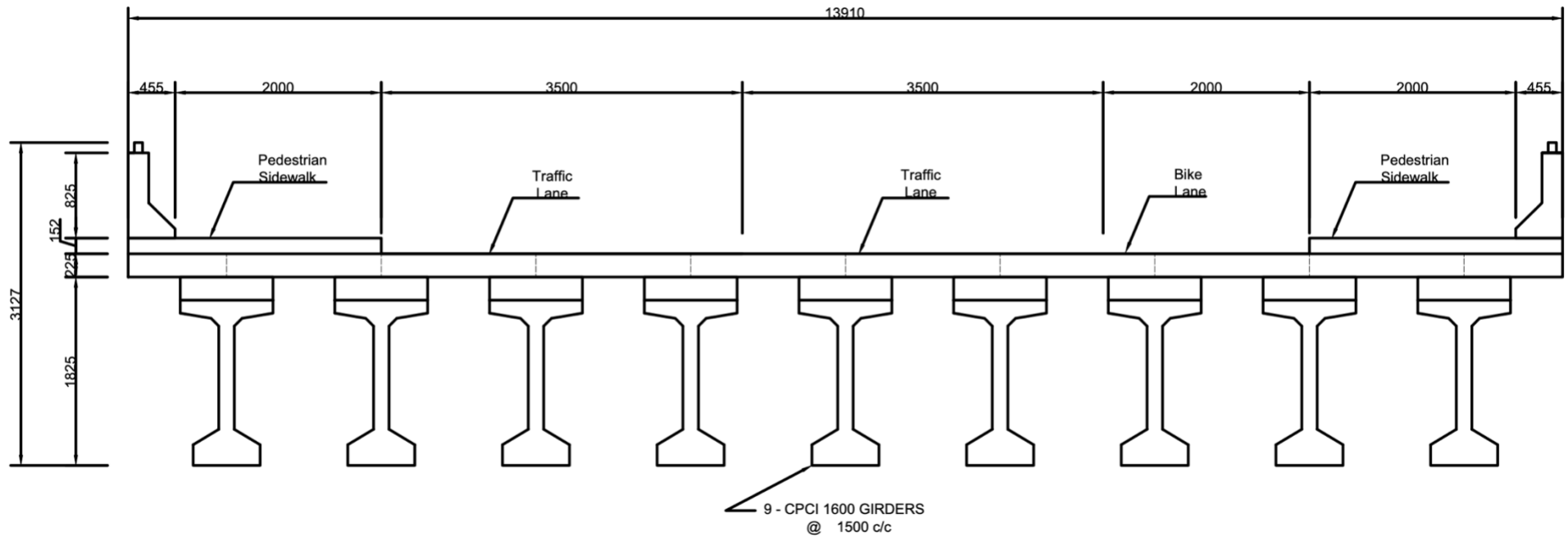

Figure 4.7 Cross-Sectional View of the Proposed Bridge

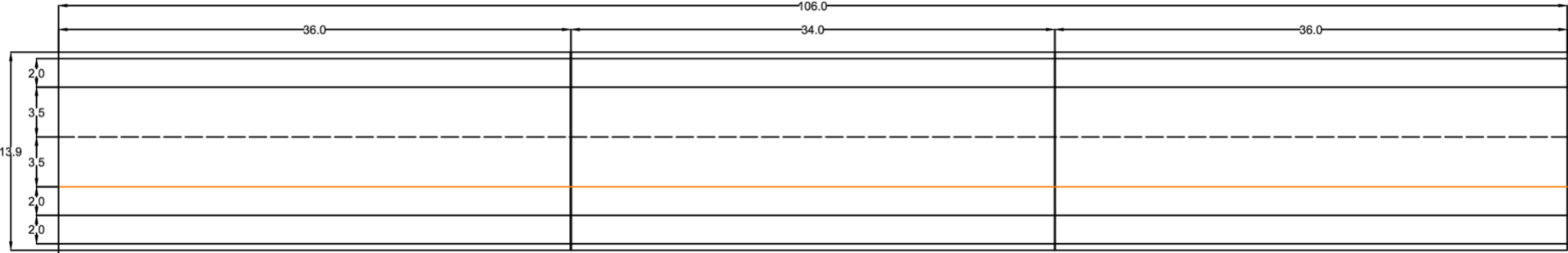

Figure 4.8 Plan View of the Proposed Bridge

4.4.1.1 Widths of Traffic Lanes, Bike Lanes, and Pedestrian Sidewalks

To design the widths of the traffic lanes, bike lanes, and sidewalks, the City of Ottawa Design Guidelines for Corridor Components (City of Ottawa, 2018) was consulted. It is the municipal guideline followed in Ottawa where the bridge is to be reassembled. For traffic lanes, the guideline states that the design widths are to be based on the road design speed, traffic volume, number and type of trucks and buses, and the available right-of-way. This translates to traffic lane widths of 3.5 to 3.75 m for higher-speed roads and 3.25 to 3.5 m for lower-speed roads. The original bridge had a posted speed limit of 60 km/hr with traffic lane widths of 3.5 to 3.75 m. For the redesigned bridge, the speed limit will be the same, however, the width will be 3.5 m for all lanes. With regards to sidewalks, the guidelines state that it must be at least 2 m wide to allow for the simultaneous passage of a pedestrian and a wheelchair. Therefore, the sidewalk width will be 2 m. For bike lanes, it states that dedicated cycling lanes are to be 1.5 to 2.5 m in width and that the measurements include a 0.25 m offset when located adjacent to a curb. Therefore, the bike lane for this redesigned bridge will be 2.0 m (1.75 m plus a 0.25 m offset due to the sidewalk curb). Note that a new wearing surface will be added to provide a smooth riding surface and it will be sloped to provide adequate drainage.

4.4.1.2 Other Design Considerations

The design changes between the existing bridge and the new bridge are outlined in Table 4.3. Note that for this analysis, one direction of traffic of the existing bridge and one of the twin bridges of the new bridge were compared against each other. Since this bridge is made with reused components, a conservative design approach was followed which was largely dictated by the width of the slab strips extracted from the original bridge. The total deck width for the reconstructed bridge is approximately one metre smaller than the original structure. The girder spacing was reduced by approximately 30%, thus requiring more girders to be required per span. Lastly, the free edge overhang was lowered by 660 mm.

Table 4.3 Component Changes After Redesign

Component	Existing Design	New Redesign
Deck Width	14 930 mm	13 910 mm
Girder Spacing	7 at 2100 mm c/c	9 at 1500 mm c/c
Lane Width	3500-3750 mm	3500 mm
Median Width	5000 mm	N/A
Shoulder Width	1000 mm	N/A
Cycling Lane Width	N/A	2000 mm
Sidewalk Width	2000 mm	2000 mm
Barrier Wall Width	455 mm	455 mm
Free Edge	1165 mm	505 mm

In Table 4.4, a summary of the percentage of reuse for each superstructure element type is showcased. The girders had the lowest reuse proportion with 77% of girders from the original bridge used in the reconstructed bridge. Conversely, since the redesigned geometry incorporates a twin bridge design, more barrier walls with railings will be needed than are available from the original structure. More barrier walls with railings would therefore need to be fabricated to accommodate the new design.

Table 4.4 Component Percentage Reused

Component	Original	Reused	Percentage Reused
Girders	70	54	77%
Deck Slabs	5046 m ²	4223 m ²	84%
Barrier Walls with Railings	348 m	424 m	122%*

*Implies that existing inventory is not sufficient. In these scenarios, additional barrier walls and railings will be fabricated.

4.4.2 Load Calculations

4.4.2.1 Live Load Calculations

4.4.2.1.1 quickBridge Analysis

A simple tool called quickBridge was used to obtain moment and shear envelopes for the reconstructed bridge. quickBridge is a programmed Excel file that generates moment and shear envelopes for bridges developed by Dr. Noyan Turkkan from the Université de Moncton. The data provided below under “CL-625-ONT Truck Analysis” and “CL-625-ONT Lane Load Analysis” were used as inputs for the redesigned bridge. Two analyses were conducted, one for the CL-625-ONT Truck and one for the CL-625-ONT Lane Load to establish which case governs. Note that since the bridge girders are simply supported (and not continuous), the bridge was reviewed one span at a time. Since spans 1 and 3 are the same length of 36 m, they were grouped together. For span 2 of 34 m, a separate review was done. Only the governing case data is shared here, however, the other cases can be found in Appendix B.

CL-625-ONT Truck Analysis

In Ontario, the CL-625-ONT Truck shown in Figure 4.9 is used to compute the live loading. For the Excel sheet titled “Truck Definition” in the software, the truck’s number of axles, and their respective coordinate and weights were entered. For the Excel sheet titled “Bridge Geometry”, the bridge’s number of spans, their lengths, the applied uniform loads, and number of divisions for analysis is inputted. In this analysis, there is no uniform load and as such, 0 is entered.

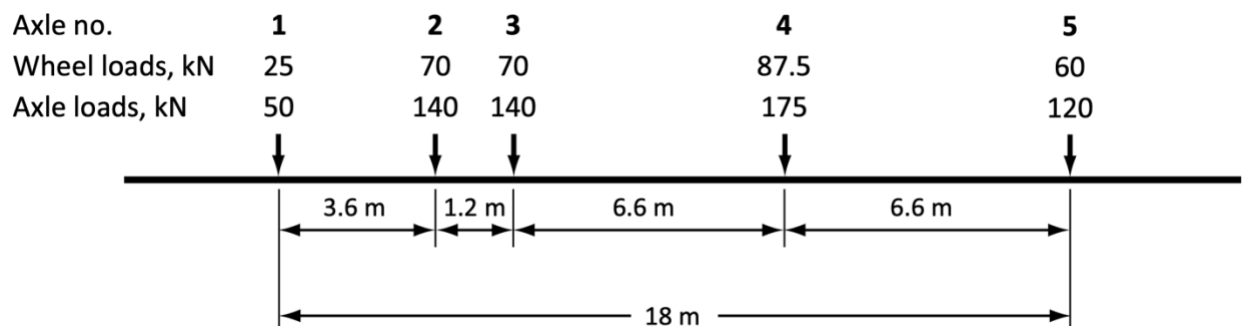

Figure 4.9 CL-625-ONT Truck Live Loading (CSA S6:19)

CL-625-ONT Lane Load Analysis

In Ontario, the CL-625-ONT Lane Load shown in Figure 4.10 is used to compute the live loading. Similarly, like in the CL-625-ONT Truck analysis, for the Excel sheet titled “Truck Definition” in the software, the truck’s number of axles, and their respective coordinate and weights were entered. For the Excel sheet titled “Bridge Geometry”, the bridge’s number of spans, their lengths, the applied uniform loads, and number of divisions for analysis is inputted. Unlike the previous section, in this analysis, there is a 9 kN/m uniformly distributed load.

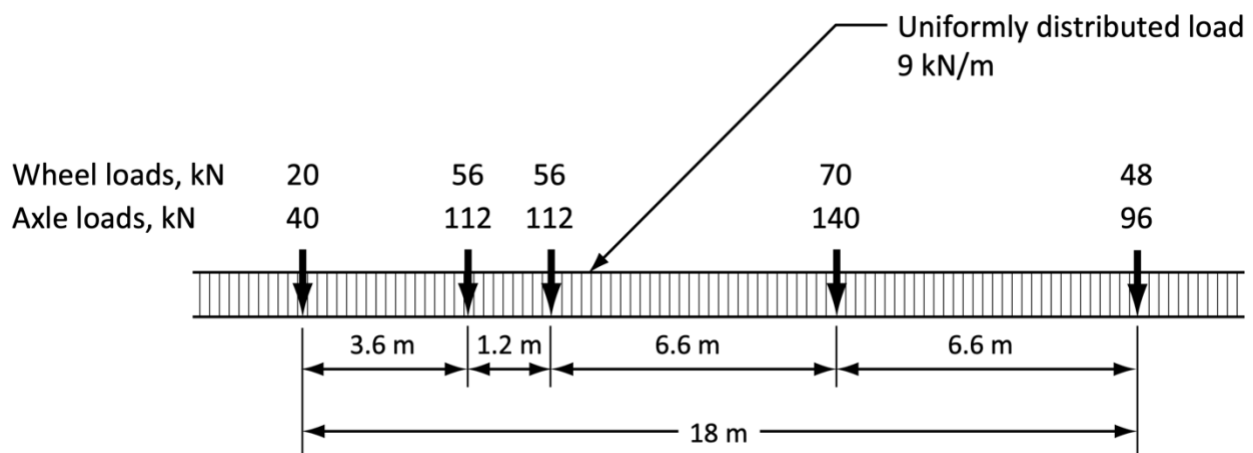

Figure 4.10 CL-625-ONT Lane Load (CSA S6:19)

Summary

Using the shear and moment envelope graphs collected from computing the CL-625-ONT Truck and the CL-625-ONT Lane Load analyses, the maximum shear and moment values were extracted. The governing case was found to be the CL-625-ONT Truck without lane load. The shear and moment envelopes obtained from the software for this case are shown in Table 4.5 and Table 4.6 demonstrates those governing values for shear and moment per span. These will be the live load design values for the bridge.

Table 4.5 Governing Values for Moment and Shear

Component	Spans 1 & 3	Span 2
$M_{T_{max}}$ (kNm)	5126.1	4748.8
$V_{T_{max}}$ (kN)	605.5	594.6

Note that the values in the table above have been increased from the maximum values shown in the graphs to account for the dynamic load allowance factor of 0.25 as per the provisions of CSA S6:19.

4.4.2.1.2 Beam Analogy Method Analysis

The beam analogy method is used here to find the longitudinal load effects for the girders. The equations below are obtained from section 5.6 in CSA S6:19 titled Simplified Method of Analysis for Longitudinal Load Effects. Subsection 5.6.2 details the conditions for use of the method for the analysis of dead and traffic loads, summarized in Table 4.7. Note that calculations here are only done for the girders, not the slab. Since the slab design meets the requirements of the Empirical Design Method specified by CSA S6:19, detailed design calculations are not necessary since the slab capacity will be dominated by arching action.

Table 4.6 Governing Shear and Moment Envelopes from the CL-625-ONT Truck for All Spans With quickBridge

Span	Direction	Shear Envelope	Moment Envelope
1 & 3	Left to Right		
2	Left to Right		

Table 4.7 Conditions Check for the Use of the Beam Analogy Method

Condition	Check
Width of the bridge is constant	✓
Deck is continuous along the entire bridge width	✓
Span between the centreline of supports or bearing units is constant throughout the width of the bridge	✓
Support conditions are closely equivalent to line support in all cases	✓
Limited curvature	✓
Proper bracing systems or diaphragms	✓
For slab-on-girder bridges: <ul style="list-style-type: none"> ▪ There are at least three longitudinal girders supporting the deck; ▪ Girders have the same flexural rigidity ▪ Girders are equally spaced ▪ Minimum girder spacing is 0.6 m; ▪ Maximum girder spacing is 4.0 m; ▪ Slab thickness is 175 mm or more; ▪ Girder spacing to the slab depth ratio is 18 or less; ▪ Overhang length S_C does not exceed the smaller of 1.80 m or 60% of the mean spacing between the longitudinal girders; and ▪ Limited skew effect 	✓

Longitudinal effects due to the CL-W loading shall be obtained by treating the bridge as a group of parallel beams. The longitudinal moment M_L and the longitudinal vertical shear V_L , to be determined per girder for slab-on-girder bridges, shall be calculated as follows:

$$M_L = F_T M_T$$

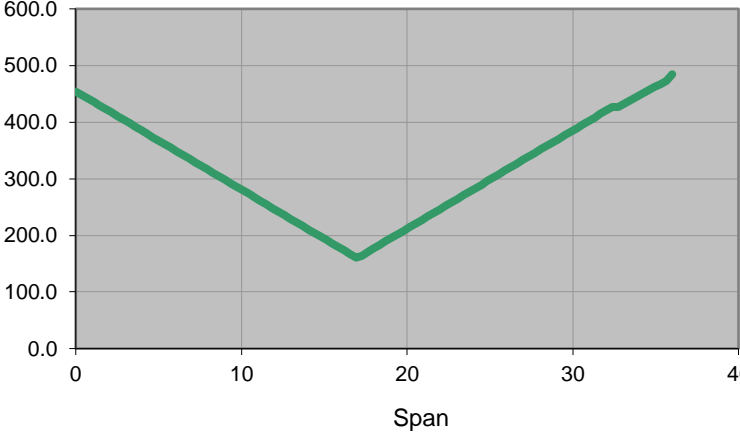
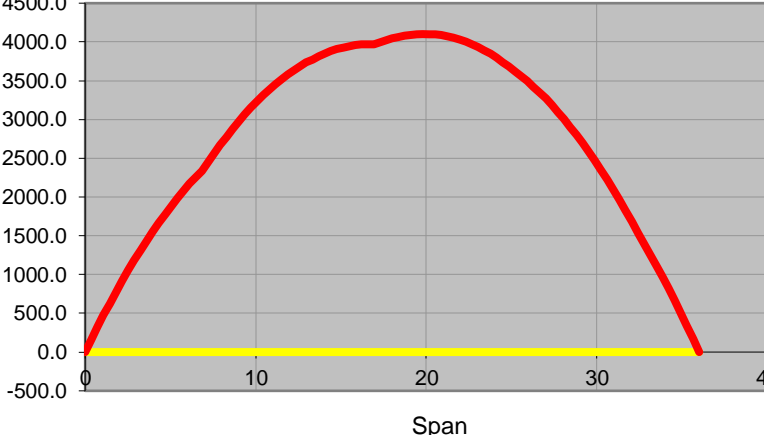
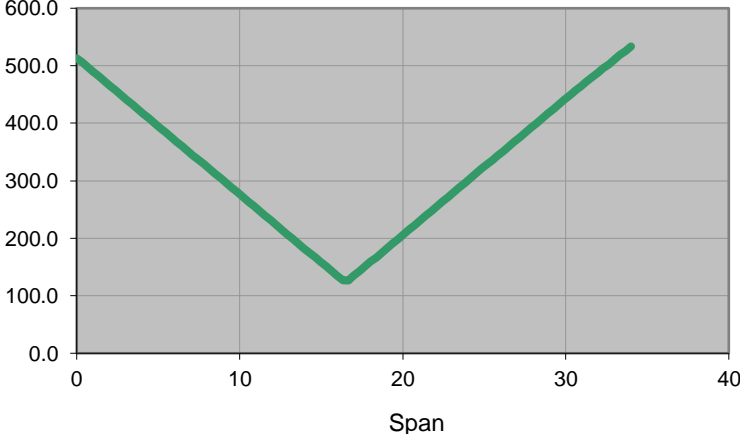
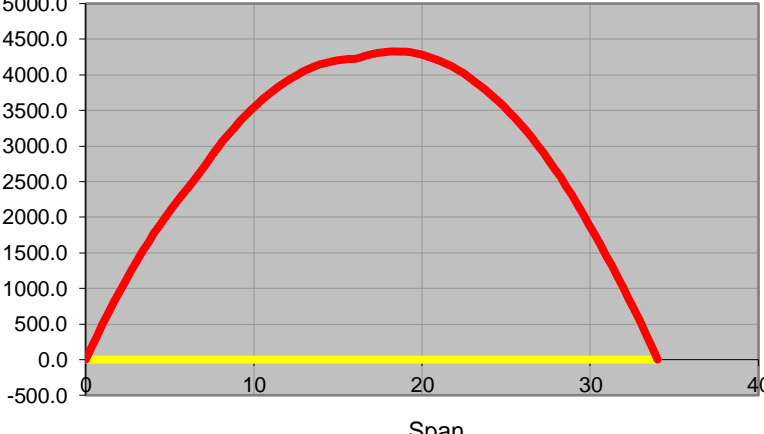
Equation 4.1

M_L : Longitudinal moment per girder due to the CL-W loading for girder-type bridges

F_T : Truck load fraction

M_T : Longitudinal moment generated by one lane of CL-W loading

$$V_L = F_T F_S V_T \quad \text{Equation 4.2}$$

V_L : Longitudinal shear per girder due to the CL-W loading for girder-type bridges

F_S : Skew factor

V_T : Longitudinal shear generated by one lane of CL-W loading

With M_T and V_T previously found and outlined in Table 4.5, only F_S , the skew factor, and F_T , the truck load fraction, need to be computed. Since the redesigned bridge is non-skewed, then as per clause 5.6.4.6, the value of the skew factor F_S shall be equal to 1.0. Meanwhile, the truck load fraction shall be calculated as per clause 5.6.4.3 with the following equation for ULS:

$$F_T = \frac{S}{D_T \gamma_c (1 + \mu \lambda)} \geq 1.05 \frac{n R_L}{N} \quad \text{Equation 4.3}$$

S : Centre-to-centre spacing of longitudinal girders of a deck-on-girder bridge

D_T : Truck load distribution width

γ_c : Truck load modification factor for slab-on-girder bridges

μ : Lane width modification factor

λ : Lane width parameter

n : Number of design lanes on a bridge

R_L : Modification factor for multi-lane loading

N : Number of longitudinal girders in the bridge deck width B

The deck width, W_c , measured from curb to curb yields 8.75 m. Using Table 3.5 in CSA S6:19, this yields 2 design lanes ($n = 2$) of 3.5 m width ($W_e = 4.375$ m). The lane width modification factor, μ , shall be calculated as follows with clause 5.6.4.4:

$$\mu = \frac{W_e - 3.3}{0.6} \leq 1.0 \quad \text{Equation 4.4}$$

W_e : Width of a design lane

Following clause 5.6.4.6 (a), for simply supported spans, L_e shall be equal to the span length. As per Table 5.3 in CSA S6:19, factors D_T , λ , and γ_c for slab-on-girder bridges for Class A and B highway in the ULS condition and for 2 design lanes (i.e., $n = 2$) are calculated as follows:

1. Load Effect: Moment Interior

$$D_T = 4.60 - \frac{5.30}{\sqrt{L_e + 5}} \geq 2.80 \quad \text{Equation 4.5}$$

L_e : The equivalent span length specified for the uses of the beam analogy method

$$\lambda = 0.10 - \frac{0.25}{L_e} \quad \text{Equation 4.6}$$

$$\gamma_c = 1.0 \quad \text{Equation 4.7}$$

2. Load Effect: Moment Exterior

$$D_T = 3.40 + \frac{L_e}{500} \quad \text{Equation 4.8}$$

$$\lambda = 0.10 - \frac{0.25}{L_e} \quad \text{Equation 4.9}$$

$$\gamma_c = 1.25 - 0.50S_c/S \leq 1.0 \quad \text{Equation 4.10}$$

S_c : Transverse distance from the free edge of the cantilever overhang slab to the centreline of the web of the exterior girder

Note that γ_c equation for moment exterior was obtained from Table 5.5 in CSA S6:19 as advised in Table 5.3.

3. Load Effect: Shear

$$D_T = 3.40 \quad \text{Equation 4.11}$$

$$\lambda = 0.0 \quad \text{Equation 4.12}$$

$$\gamma_c = \left(\frac{S}{2.0}\right)^{0.25} \leq 1.0 \quad \text{Equation 4.13}$$

Note that γ_c equation for shear was obtained from Table 5.6 in CSA S6:19 as advised in Table 5.3. Table 4.8 on the following page summarizes the findings for the live moment and shear per girder with the last three columns being the final values used for design (in **bold**).

Table 4.8 Live Moment and Shear Per Girder Results

Component		Symbol	Spans 1 & 3	Span 2	Checks
Live Load Factor		ULS	1.70	1.70	
Deck Width		W_c (m)	8.75	8.75	
Number of Design Lanes		n	2.00	2.00	
Design Lane Width		W_e (m)	4.375	4.375	
Lane Width Modification Factor		μ	1.00	1.00	≤ 1.00 Cap
Skew Factor		F_S	1.00	1.00	
Span Length		L_e (m)	36.00	34.00	
Number of Girders		N	9.00	9.00	
Girder Spacing		S	1.50	1.50	
Free Edge		S_c (m)	0.83	0.83	
Modification Factor for Multi-Lane Loading		R_L	0.90	0.90	
For Moment Interior	Truck Load Distribution Width	D_T	3.77	3.75	≥ 2.80 OK
	Lane Width Parameter	λ	0.09	0.09	
	Truck Load Modification Factor	γ_c	1.00	1.00	
For Moment Exterior	Truck Load Distribution Width	D_T	3.47	3.47	
	Lane Width Parameter	λ	0.00	0.00	
	Truck Load Modification Factor	γ_c	0.97	0.97	≤ 1.00 OK
For Shear	Truck Load Distribution Width	D_T	3.40	3.40	
	Lane Width Parameter	λ	0.00	0.00	
	Truck Load Modification Factor	γ_c	0.93	0.93	≤ 1.00 OK
For Moment Interior	Truck Load Fraction	F_T	0.36	0.37	≥ 0.21 OK
For Moment Exterior	Truck Load Fraction	F_T	0.44	0.44	≥ 0.21 OK
For Shear	Truck Load Fraction	F_T	0.47	0.47	≥ 0.21 OK
Unfactored	Moment from Loading	M_T (kNm)	5126.1	4748.8	
	Shear from Loading	V_T (kN)	605.5	594.6	
Factored	Moment from Loading	M_T (kNm)	8714.4	8073.0	
	Shear from Loading	V_T (kN)	1029.4	1010.8	
For Moment Interior	Moment Per Girder	M_L (kNm)	3170.2	2954.3	
For Moment Exterior	Moment Per Girder	M_L (kNm)	3868.0	3587.4	
For Shear	Shear Per Girder	V_L (kN)	488.0	479.2	

4.4.2.2 Dead Load Calculations

In this subsection, the dead load sustained by each girder is calculated. To find that value, the girder self-weight is found first, comprising the girder weight obtained from the CPCI manual and the deck slab component that is now on top of the girder. Next, the deck slab self-weight is calculated (the values diverge for interior girders and exterior girders). Lastly, the barrier wall self-weight is found for the exterior girders only as it will solely be sustained by them. The appropriate values are then summed for the interior girder and exterior girder and later factored using the load factor for dead load, α_D , of 1.20 from Table 3.3 in CSA S6:19. Those values are found for spans 1 & 3 and span 2. Their results are outlined in Table 4.9. Note that normal density concrete is used, therefore, γ equalling 24 kN/m^3 is taken.

Table 4.9 Dead Load Per Girder Results

Component		Weight (kN/m)
Girder Self-Weight	Girder	11.8
	Deck Slab	4.9
	Total	16.7
Deck Slab Self-Weight	Interior Girder	8.1
	Exterior Girder	13.6
Barrier Wall Self-Weight	Exterior Girder	5.0
Unfactored Total for Interior Girder		24.8
Unfactored Total for Exterior Girder		35.3
Factored Total for Interior Girder		29.7
Factored Total for Exterior Girder		42.3

Since the dead load effects carried by the girder will be uniformly distributed, the moment at the midspan due to dead load will be calculated using Equation 4.14 and the shear will be calculated using Equation 4.15. Since the total factored dead load of the exterior girder and the length of spans 1 and 3 will provide more critical results, they were used to compute the values below.

$$V_D = \frac{w_f l}{2}$$

Equation 4.14

V_D : Factored shear due to dead load per girder

w_f : Total dead factored load carried by girder

l : Span length

$$V_D = \frac{\left(42.3 \frac{kN}{m}\right) (36 m)}{2} = 761.4 kN$$

$$M_D = \frac{w_f l^2}{8}$$

Equation 4.15

M_D : Factored moment due to dead load per girder

$$V_D = \frac{\left(42.3 \frac{kN}{m}\right) (36 m)^2}{8} = 5152.6 kN \cdot m$$

4.4.2.3 Total Load Calculations

The factored shear force and factored moment can be found by adding the values found prior.

$$V_f = V_L + V_D = 488.0 kN + 761.4 kN = 1204.4 kN$$

$$M_f = M_L + M_D = 3868.0 kN \cdot m + 5152.6 kN \cdot m = 9020.6 kN \cdot m$$

4.4.3 Capacity Calculations

4.4.3.1 Preliminary Inputs

In this subsection, preliminary properties needed to compute the capacity calculations are established. Table 4.10, Table 4.11, Table 4.12, Table 4.13, and Table 4.14 provide the summary

of the concrete material properties, girder section properties, prestressing tendons properties, reinforcing steel properties, and material resistance factors, respectively. Some of the data presented in these tables have been obtained from the drawings, while others were calculated using equations taken from Canadian Highway Bridge Design Code and the Concrete Design Handbook. Therefore, some of the tables below will be preceded by equations and calculations used to find certain properties seen in the tables.

Table 4.10 presents the concrete material properties. To obtain the value for the cracking strength of concrete, Equation 4.16 for normal density concrete is used. The modulus of elasticity of concrete is obtained using Equation 4.17.

$$f_{cr} = 0.4\sqrt{f'_c} \text{ for normal density concrete} \quad \text{Equation 4.16}$$

f_{cr} : Cracking strength of concrete

f'_c : Specified compressive strength of concrete

$$f_{cr} = 0.4\sqrt{40 \text{ MPa}} = 2.53 \text{ MPa} \leq 3.2 \text{ MPa} \therefore \text{OK}$$

$$E_c = 4500\sqrt{f'_c} \quad \text{Equation 4.17}$$

E_c : Modulus of elasticity of concrete

$$E_c = 4500\sqrt{40 \text{ MPa}} = 28460 \text{ MPa}$$

Table 4.10 Concrete Material Properties

Property	Value
Concrete unit weight, γ	24 kN/m ³
Concrete compressive strength, f'_c	40 MPa
Concrete cracking strength, f_{cr}	2.53 MPa
Concrete modulus of elasticity, E_c	28460 MPa

Table 4.11 provides the girder section properties. In Figure 4.11, the measurements for the CPCI 1600 girder are shown, as retained from the drawings. Note that the girder height for the repurposed bridge is adjusted in the table from 1600 mm to 1825 mm to account for the composite deck slab that will be part of the ‘new’ girder.

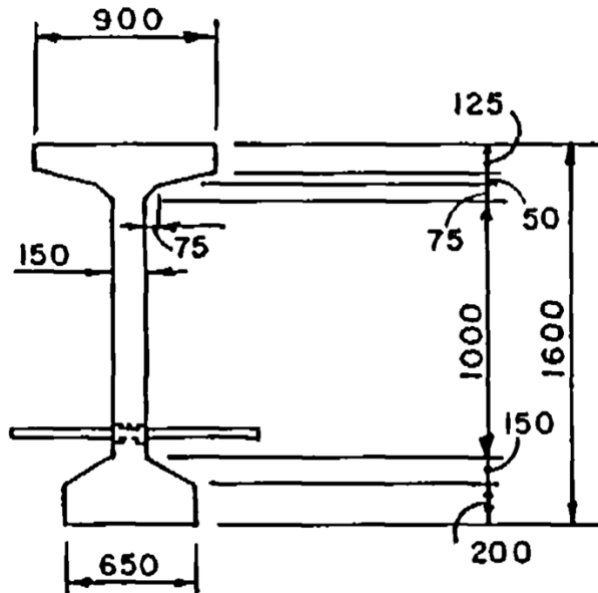

Figure 4.11 CPCI 1600 Girder Dimension from Bridge Plans

Table 4.11 Girder Section Properties

Property	Value
Height, h	1825 mm
Upper flange width, b	900 mm
Flange height, h_f	375 mm
Web width, b_w	150 mm
Lower flange width, b	650 mm

Table 4.12 shows the prestressing tendon properties. The stress in the prestressed reinforcement when the stress in the surrounding concrete is zero, f_{po} , is found using Equation 4.17 as per CSA S6:19. The distance from the extreme compression fibre to the centroid of the prestressing tendons was calculated twice, once at the end of the girder with only 30 prestressing tendons in the tension zone, and again at the midpoint of the girder with all 46 prestressing tendons in the tension zone.

$$f_{po} = 0.7f_{pu} \text{ for bonded tendons}$$

Equation 4.18

f_{po} : Stress in prestressed reinforcement when stress in the surrounding concrete is zero

f_{pu} : Specified tensile strength of prestressing steel

$$f_{po} = 0.7(1860 \text{ MPa}) = 1302 \text{ MPa}$$

Table 4.12 Prestressing Tendons Properties

Property	Value
Strand diameter	13 mm
Area of strand	99 mm ²
Number of tendons	46
Prestressing tendons area, A_{ps}	4554 mm ²
Force in tendon after losses	105.9 kN
Distance from extreme compression fibre to centroid of the prestressing tendons, d_p (mid)	1656 mm
Distance from extreme compression fibre to centroid of the prestressing tendons, d_p (end)	1692 mm
Prestressing tendons specified tensile strength, f_{pu}	1860 MPa
Stress in prestressing tendons when strain in the surrounding concrete is zero, f_{po}	1302 MPa
Prestressing tendons modulus of elasticity, E_p	200000 MPa

Table 4.13 provides the reinforcing steel properties in the compression zone of the girder. There are two 10M steel bars in the upper flange of the girder giving a compression reinforcement area of 400 mm².

Table 4.13 Compression Steel Properties

Property	Value
Compression reinforcement area, A'_s	400 mm ²
Steel yield strength, f_y	400 MPa
Distance from extreme compression fibre to centroid of the top reinforcement, d'	275 mm

Table 8.1 Material Resistance Factors in CSA S6:19 provides resistance factors for Concrete, Reinforcement, and Anchor Rods and Studs. Table 4.14 shows the material resistance factors that are taken from the reference manual to be used in the capacity calculations.

Table 4.14 Material Resistance Factors

Material	Material Resistance Factor
Concrete, ϕ_c	0.75
Reinforcing bars, ϕ_s	0.90
Prestressing strands, ϕ_p	0.95

4.4.3.2 Shear Resistance

To find the factored shear resistance of the girder, three sub elements must be calculated first: the factored shear resistance provided by prestressed tendons, the factored shear resistance provided by the concrete, and the factored shear resistance provided by shear reinforcement.

To obtain the prestressing tendons contribution to shear, Equation 4.19 is used. Figure 4.12 from the construction drawings shows the tendon profile inside the girders. The profile is used to calculate alpha in the equation. The girder has 16 inclined tendons contributing to the shear strength, they are low relaxation, 7-wire strand, size 13, and grade 1860. The force per strand after losses is 105.9 kN as stated from the construction notes. Girder B is the longer than girder A, as such, it is the critical case and will be governing. The calculation for girder A is presented in the Appendix B.

$$V_p = \phi_p F_{pe} \sin \alpha$$

Equation 4.19

V_p : Factored shear resistance provided by prestressed tendons

ϕ_p : Resistance factor for reinforcing tendons

F_{pe} : Effective stress in prestressing tendons after allowance for all prestress losses

α : Vector sum of angular changes in elevation and plan of a prestressing tendon profile from the jacking end to any point x

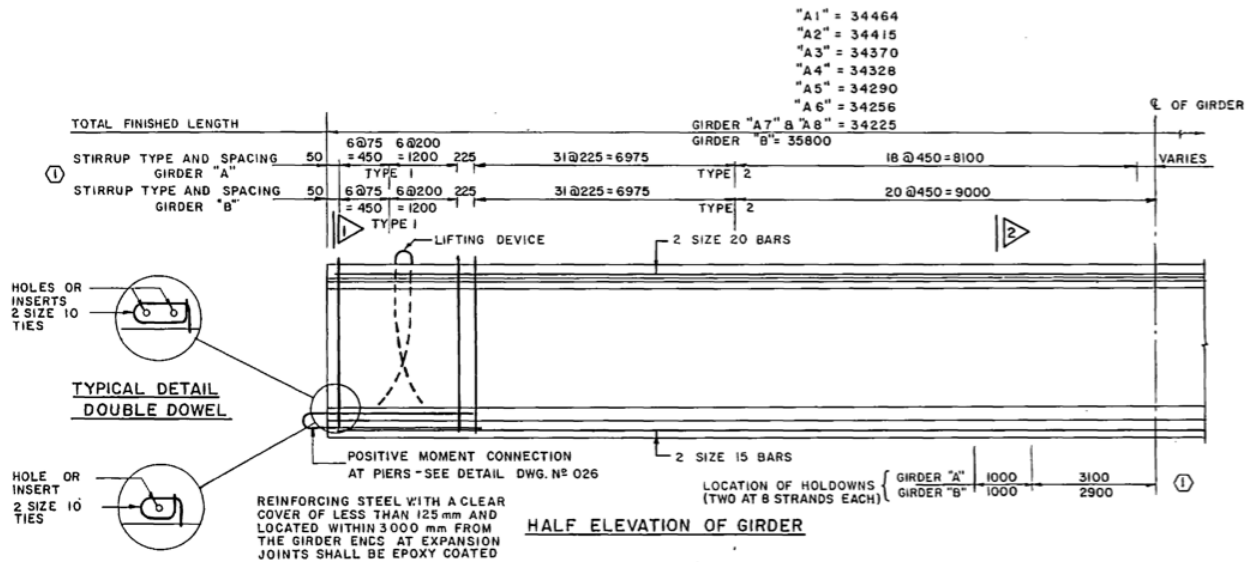

Figure 4.12 Tendon Profile

Table 4.15 Prestressing Steel Shear Contribution in Girder B

Number of Strands	Adjacent Distance (m)	Opposite Distance (m)	α (°)	F_{pe} (kN)	$\phi_p F_{pe} \sin \alpha$ (kN)
2	14	0.4400	1.80	211.80	6.32
2	14	0.5900	2.41	211.80	8.47
2	14	0.7400	3.03	211.80	10.62
2	14	0.8900	3.64	211.80	12.77

Table 4.15 Continued

2	15	1.0400	3.97	211.80	13.92
2	15	1.1900	4.54	211.80	15.91
2	15	1.3400	5.10	211.80	17.90
2	15	1.4900	5.67	211.80	19.89
				$V_p =$	105.80

The longitudinal strain in the girder is found using Equation 4.20.

$$\varepsilon_x = \frac{M_f/d_v + V_f - V_p + 0.5N_f - A_{ps}f_{po}}{2(E_sA_s + E_pA_{ps})} \quad \text{Equation 4.20}$$

ε_x : Longitudinal strain

M_f : Factored moment at section

d_v : Effective shear depth

V_f : Factored shear force at a section

N_f : Factored axial load normal to the cross-section occurring simultaneously with V_f , including the effects of tension due to creep and shrinkage

A_{ps} : Area of the tendons on the flexural tension side of a member

E_s : Modulus of elasticity of reinforcing bars

A_s : Area of reinforcing bars on the flexural tension side of a member

E_p : Modulus of elasticity of tendons

$$\varepsilon_x = \frac{15.7 \times 10^6 \text{ Nmm} \div 1522.8 \text{ mm} + 1204.4 \times 10^3 \text{ N} - 105.8 \times 10^3 \text{ N} - 4554 \text{ mm}^2 \times 1302 \text{ MPa}}{2(200,000 \text{ MPa} \times 400 \text{ mm}^2 + 200,000 \text{ MPa} \times 4554 \text{ mm}^2)}$$

$$= -2.43 \times 10^{-3}$$

Negative values, therefore, taken as zero.

The simplified method for the determination of β and θ cannot be used since it is reserved for non-prestressed components. As such, the general method outlined in clause 8.9.3.7 is followed with Equation 4.21 and Equation 4.24 being used to calculate β and θ respectively.

$$\beta = \left[\frac{0.4}{1 + 1500\varepsilon_x} \right] \left[\frac{1300}{1000 + s_{ze}} \right] \quad \text{Equation 4.21}$$

β : Factor used to account for the shear resistance of cracked concrete

s_{ze} : Equivalent value of s_z that accounts for influence of aggregate size

$$\beta = \left[\frac{0.4}{1 + 1500(0)} \right] \left[\frac{1300}{1000 + 300 \text{ mm}} \right] = 0.400$$

$$d_v = \text{Greater of } 0.72h \text{ or } 0.9d \quad \text{Equation 4.22}$$

d_v : Effective shear depth

d : Distance from the extreme compression fibre to the centroid of the longitudinal tension reinforcement in the half-depth of the section containing the flexural tension zone

$$d_v = \text{Greater of } 0.72(1825 \text{ mm}) \text{ or } 0.9(1692 \text{ mm}) = 1522.8 \text{ mm}$$

Equation 4.23 below is used to calculate the factored shear resistance provided by the tensile stresses in the concrete. The contribution is found to be 433.40 kN.

$$V_c = 2.5\beta\phi_c f_{cr} b_w d_v \quad \text{Equation 4.23}$$

V_c : Factored shear resistance provided by tensile stresses in concrete

b_w : Web width

ϕ_c : Resistance factor for concrete

$$V_c = 2.5(0.400)(0.75)(2.53 \text{ MPa})(150 \text{ mm})(1522.8 \text{ mm}) = 433.40 \text{ kN}$$

$$\theta = 29 + 7000\varepsilon_x \quad \text{Equation 4.24}$$

θ : angle of inclination of the principal diagonal compressive stresses to the longitudinal axis of a member

$$\theta = 29 + 7000(0) = 29^\circ$$

Equation 4.25 below is used to calculate the factored shear resistance provided by shear reinforcement. The contribution is found to be 1977.99 kN.

$$V_s = \frac{\phi_s f_y A_v d_v \cot \theta}{s} \quad \text{Equation 4.25}$$

V_s : Factored shear resistance provided by shear reinforcement

ϕ_s : Resistance factor for reinforcing bars

A_v : Area of transverse shear reinforcement perpendicular to the axis of a member within a distance s

s : Spacing of stirrups measured parallel to the longitudinal axis of a component

$$V_s = \frac{(0.90)(400 \text{ MPa})(400 \text{ mm}^2)(1522.8 \text{ mm})(\cot 29^\circ)}{200 \text{ mm}} = 1977.99 \text{ kN}$$

Lastly, the factored shear resistance in the girder can now be found with all the sub elements being established using Equation 4.19, Equation 4.23, and Equation 4.25. With Equation 4.26, the factored shear resistance is found to be 2837.85 kN, however, clause 8.9.3.3 in CSA S6:19 states that the shear reinforcement and prestressing tendons shear contributions shall not exceed

$0.25\phi_c f'_c b_v d_v$. Since their contribution will be 2411.39 kN and the limit is 1713.15 kN, then the contribution value will be taken as 1713.15 kN. With this adjustment, the factored shear resistance is now 1818.95 kN. Lastly, this value is further modified by the introduction of a reduction factor brought in as an additional safety measure in acknowledgement of the reduced ability to provide quality assurance for reused components. Since conducting a reliability study to calibrate risk is outside the scope of this thesis, a conservative reduction of 25% is used. This sets the factored shear resistance at 1364.21 kN.

$$V_r = V_c + V_s + V_p$$

Equation 4.26

V_r : Factored shear resistance

$$V_r = 433.40 \text{ kN} + 1977.99 \text{ kN} + 105.80 \text{ kN} = 2837.85 \text{ kN}$$

However, $V_c + V_s$ must be $< 0.25\phi_c f'_c b_v d_v$

$$433.40 \text{ kN} + 1977.99 \text{ kN} > 0.25(0.75)(40 \text{ MPa})(150 \text{ mm})(1522.8 \text{ mm})$$

$2411.39 \text{ kN} > 1713.15 \text{ kN} \therefore$ Contribution of $V_c + V_s$ will be taken as 1713.15 kN

$$V_r = 1713.15 \text{ kN} + 105.80 \text{ kN} = 1818.95 \text{ kN}$$

$$V_r = (0.75)(1818.95 \text{ kN}) = 1364.21 \text{ kN} > V_f \therefore \text{Safe}$$

4.4.3.3 Moment Resistance

In this subsection, the moment resistance of the girder is calculated. Prior to calculating the moment resistance, a few values must be found first. Two ratios, α_1 and β_1 , of the average stress in a rectangular compression block to the specified concrete strength and of the depth of rectangular compression block to depth to the neutral axis respectively, are found using Equation 4.27 and Equation 4.28. k_p , the factor dependent on the type of prestressing steel is calculated using Equation 4.29.

$$\alpha_1 = 0.85 - 0.0015f'_c \geq 0.67 \quad \text{Equation 4.27}$$

α_1 : Ratio of average stress in a rectangular compression block to the specified concrete strength

$$\alpha_1 = 0.85 - 0.0015(40 \text{ MPa}) = 0.79 > 0.67$$

$$\beta_1 = 0.97 - 0.0025f'_c \geq 0.67 \quad \text{Equation 4.28}$$

β_1 : Ratio of depth of rectangular compression block to depth to the neutral axis

$$\beta_1 = 0.97 - 0.0025(40 \text{ MPa}) = 0.87 > 0.67$$

$$k_p = 2 \left(1.04 - \frac{f_{py}}{f_{pu}} \right), \frac{f_{py}}{f_{pu}} = 0.9 \text{ for prestressing strand} \quad \text{Equation 4.29}$$

k_p : Factor dependent on the type of prestressing steel

f_{py} : Yield strength of prestressing steel

$$k_p = 2(1.04 - 0.9) = 0.28$$

$\frac{c}{d_p}$, calculated using Equation 4.30, is found to be 0.17 which is less than 0.5. This means that the simplified method using Equation 4.31 can be used to find the stress in the prestressing tendons at factored resistance. a is calculated using Equation 4.32.

$$\frac{c}{d_p} = \phi_p A_{ps} f_{pu} - \phi_s A'_s f_y - \frac{\alpha_1 \phi_c f'_c h_f (b - b_w)}{\alpha_1 \phi_c \beta_1 f'_c b_w d_p} + \phi_p k_p A_{ps} f_{pu} \quad \text{Equation 4.30}$$

h_f : Height of flange

$$\begin{aligned} \frac{c}{d_p} &= (0.95)(4554 \text{ mm}^2)(1860 \text{ MPa}) - (0.900)(400 \text{ mm}^2)(400 \text{ MPa}) \\ &\quad - \frac{(0.79)(0.75)(40 \text{ MPa})(375 \text{ mm})(900 \text{ mm} - 150 \text{ mm})}{(0.79)(0.75)(0.87)(40 \text{ MPa})(150 \text{ mm})(1656 \text{ mm})} \\ &\quad + (0.95)(0.28)(4554 \text{ mm}^2)(1860 \text{ MPa}) \\ &= 0.17 < 0.5 \therefore \text{Simplified method can be used} \end{aligned}$$

$$c = \frac{c}{d_p} \times d_p = 0.17 \times 1656 \text{ mm} = 277.8 \text{ mm}$$

$$f_{pr} = f_{pu} \left(1 - k_p \frac{c}{d_p} \right), \text{ if } \frac{c}{d_p} \leq 0.5$$

Equation 4.31

f_{pr} : Stress in prestressing tendons at factored resistance

$$f_{pr} = 1860 \text{ MPa}(1 - 0.28 \times 0.15) = 1780 \text{ MPa}$$

$$a = \beta_1 c$$

Equation 4.32

a : Depth of an equivalent rectangular stress block

$$a = (0.87)(277.8 \text{ mm}) = 241.7 \text{ mm}$$

Finally, with the values found above, the factored flexural resistance of the girder can now be computed using Equation 4.33. M_r is found to be 12366.8 kN·m, however, with the reduction factor introduced earlier, M_r is reduced by 25% to 9825.1 kN·m.

$$\begin{aligned} M_r &= \phi_s A_s f_y \left(d_p - \frac{a}{2} \right) + \phi_p A_{ps} f_{pr} \left(d_p - \frac{a}{2} \right) - \phi_s A'_s f_y \left(d' - \frac{a}{2} \right) \\ &\quad - \alpha_1 \phi_c f'_c h_f (b - b_w) \left(\frac{h_f}{2} - \frac{a}{2} \right) \end{aligned}$$

Equation 4.33

M_r : Factored flexural resistance of a section in bending

$$\begin{aligned}
 M_r = & (0.95)(4554 \text{ mm}^2)(1780 \text{ MPa}) \left(1656 \text{ mm} - \frac{241.7 \text{ mm}}{2} \right) \\
 & - (0.90)(400 \text{ mm}^2)(400 \text{ MPa}) \left(275 \text{ mm} - \frac{241.7 \text{ mm}}{2} \right) \\
 & - (0.79)(0.75)(40 \text{ MPa})(375 \text{ mm})(900 \text{ mm} \\
 & - 150 \text{ mm}) \left(\frac{375 \text{ mm}}{2} - \frac{241.7 \text{ mm}}{2} \right)
 \end{aligned}$$

$$M_r = 12366.8 \text{ kN} \cdot \text{m}$$

$$M_r = (0.75)(12366.8 \text{ kN} \cdot \text{m}) = 9825.1 \text{ kN} \cdot \text{m} > M_f \therefore \text{Safe}$$

4.4.4 Reassembly Plan of Repurposed Bridge

4.4.4.1 Proposed Connection

In a previous subsection, a plan for deconstruction of the girders was presented. Here, a proposed connection design for reassembly is shown in Figure 4.13 to demonstrate how the girder and slab will be reassembled. It is worth noting that a truly reconfigurable design should avoid the use of “wet” connections (i.e., adding new concrete or epoxy) that would interfere with future disassembly. For a fully circular economy where each component could potentially have multiple service lives, new demountable connection types should be developed; nevertheless, such designs require extensive testing and are thus considered outside the scope of this thesis. This presents an opportunity for future work.

Upon installation of the girders, two different slab strips will be placed on top of each girder. To ensure a strong connection between the two slab strips is formed, 1-inch diameter headed steel dowel bars (25M shear connectors) are to be installed vertically to connect the slab strips to the girder. For the transverse joint – the slab-to-slab joint – 15M stainless steel or FRP reinforcing bars will be placed in grooves near the surface to prevent corrosion. The grooves, dowel cavities, and gaps in-between slabs will be filled with ultrahigh-performance concrete (UHPC) to provide continuity between the various components. Cast-in-place diaphragms will also be installed over

the pier supports. Finally, a new wearing surface will be placed over the entire assembly. Additional design details and calculations are presented in the following subsection.

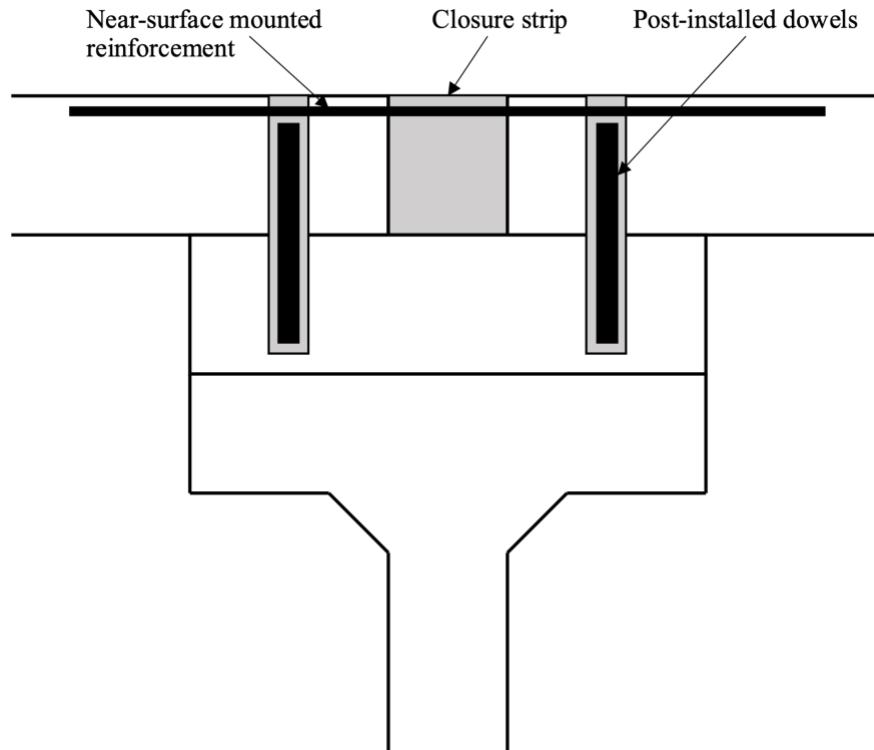

Figure 4.13 Proposed Girder-Slab Connection

4.4.4.2 Connection Design

In this subsection, the calculations for the connection design are done. Equation 4.34 is used to find the shear force to be resisted by the post-installed dowels using the conservative assumption that the maximum tension or compression force resultant is fully transferred across the horizontal shear plane. Holes will be drilled and then the dowels will be embedded, and it will be filled with non-shrink high-strength grout. The middle span, span 2 of 34 m, was used for the design as it is the shorter span and thus more critical than spans 1 and 3 with respect to the critical shear plane for composite deck action. It is calculated that using one pair of 30M bars placed every 50 cm and embedded 550 mm as per the calculation derived using Equation 4.35. The near-surface mounted reinforcement is designed to match the original reinforcement ratio from the City of Ottawa bridge for this hypothetical bridge. Therefore, the design will use 400 MPa steel grade, 15M bar size, and be spaced 150 mm centre-to-centre.

$$C_c = T_p = \phi_p A_{ps} f_{pr}$$

Equation 4.34

C_c : Compression force in concrete

T_p : Tension force in prestressed tendons

$$C_c = 0.95 \times 4554 \text{ mm}^2 \times 1780 \text{ MPa}$$

$$C_c = 7701 \text{ kN}$$

Using span 2 of 34 m for design as it is more critical than spans 1 and 3 of 36 m,

and assuming a uniformly distributed shear force along the span length:

$$\frac{C}{L} = \frac{7701 \text{ kN}}{17 \text{ m}} = 453 \text{ kN/m}$$

Using 30M bars placed in pairs:

$$\frac{453 \text{ kN}}{2} = 227 \text{ kN/pair}$$

$$0.6f_y = (0.6)(400 \text{ MPa}) = 240 \text{ MPa}$$

$$240 \text{ MPa} \times 700 \text{ mm}^2 = 168 \text{ kN}$$

\therefore Use 1 pair of 30M bars placed every 50 cm.

$$l_{db} = \frac{0.24d_b f_y}{\sqrt{f'_c}} \quad \text{but not less than } 0.044d_b f_y$$

Equation 4.35

l_{db} : Basic development length

$$l_{db} = \frac{0.24(30 \text{ mm})(400 \text{ MPa})}{\sqrt{40 \text{ MPa}}} = 455.4 \text{ mm}$$

$$0.044d_b f_y = 0.044(30 \text{ mm})(400 \text{ MPa}) = 528.0 \text{ mm governs} \rightarrow \text{use } 550 \text{ mm}$$

4.5 Discussion

This case study focused on the deconstruction and repurposing of a five-span I-girder bridge located in Ottawa's east end. A disassembly plan for the superstructure elements of this existing bridge was proposed, and an inventory of the reusable bridge components was developed. To build on the current work, it is recommended that experimental research and numerical modelling be conducted in the future to verify the conceptual strategies proposed in this chapter, and to develop and optimize demountable connection types.

When the hypothetical new bridge was designed, its geometry was somewhat constrained to the old design. The twin bridge design required more barrier walls with railings to be fabricated to cover the edges of both bridges. Not all of the superstructure components available in the inventory were reused; this was a natural result of the distinct geometry of the redesigned bridge, but also allows for some elements to remain as backup resources in the case of accidental damage whilst elements are being cut or transported. Since the structural elements of a bridge are external and are exposed to harsh weather, a conservative 0.75 reduction factor was introduced to account for potential owner hesitancy and challenges associated with quality assurance of reused components. However, it is advised that reliability studies be conducted to calibrate the risk of reused concrete components, and that classification and rating systems be developed together with rapid non-destructive testing technologies to increase confidence in their use.

The reassembly plan focused on the connection design of the girder-slab. The connection proposed is reconfigurable, however, extensive testing of this connection and other potential alternative connections will be needed in the future to provide flexibility in the design. The bridge in question was not designed with reuse in mind, as such, impeding the deconstruction and reconstruction processes. To facilitate concrete reuse – and reuse in general – infrastructure would ideally be designed with its future dismantlement taken into consideration. Only the reuse of superstructure elements was undertaken in this study; as previously noted, research on reuse of substructure bridge components is available but is typically only applicable to cases when a new structure is being built in the same location as the original allowing the foundations to be left in place.

One of the biggest challenges observed in this process was conceiving several modes of cutting the structural elements, and then selecting the most favourable option as part of the overarching disassembly plan. Conceptualizing those ideas requires creative thinking and engineering expertise. Having field experience is also extremely helpful for designers as their understanding of how engineering projects develop on site will aid them in being more imaginative yet remaining practical. Selecting the final mode of deconstruction is a balancing act as some options will be favourable in one area (e.g., logistically) and unfavourable in another (e.g., technically). This was noted when selecting a cut option for the girder as some options were easier to transport but more challenging to reconnect later. Therefore, it is important to understanding the constraints of the project (e.g., time, money, or transport) and select a deconstruction plan that is appropriate for the project in question.

While the objective of this case study has been achieved, it has certainly uncovered questions that need to be addressed. For instance, regarding the structural behaviour of the girder-slab composite action, is any surface preparation required to enhance the friction and/or bond at their interface? Experimental testing would certainly be needed to bring clarity to this and related issues. Another question, related to the limitation of this approach, are there components that cannot be reused and need to be recycled? If so, how can that be optimally decided? Certainly, some limitations do exist, however, to fully understand the confines, real life case reuse scenarios are needed to arrive at a conclusive answer. It is also important to highlight that this will be dependent on the structure in question as the answer to that question might vary from structure to structure. In conclusion, the feasibility of reusing concrete bridge components seems plausible, however, more research – especially experimentally and using finite element models – needs to emerge prior to this being implemented on site and becoming common practice long term.

5 Chapter 5: University of Ottawa Building Case Study

5.1 Background

This chapter presents a second conceptual case study developed for the Faculty of Social Sciences (FSS) Building at the University of Ottawa (UO) built in 2012. In contrast to the bridge example, the FSS Building was intentionally selected because of its irregular form which adds considerable complexity that inhibits its adaptability and potential for reuse. Whereas a simpler building type would facilitate the reuse process and likely represents a more realistic use case, the inherent complexity of the FSS Building allows for the identification of more of the challenges and limitations of the reuse concept for concrete structures. Moreover, by focusing on a relatively recently constructed building it was possible to avoid the difficulties that can arise when attempting to retain drawings and building information of older structures as their full availability is not always guaranteed.

One of the obvious challenges associated with the FSS Building is its irregular layout. There are three ‘sub’ buildings in the structure with different heights and asymmetrical floor plans. As a result, there are many variations between structural members of the same type. For example, a circular concrete column on one floor continues as a square on another floor and is rectangular on another, thus introducing many different designs; there is also little to no uniformity in the individual column designs. Since the FSS Building is designed as a mostly flat slab structure, there are few beams present in the structure. However, amongst the beams that exist only the elevator beam remains the same throughout all the floors while all the others are designed differently. Due to the irregular shape of the floor plans, retaining slab pieces for reuse was also not straightforward. In consequence, significant proportions of the concrete slab will not be salvaged as they are deemed impractical for reuse.

It is important to mention that there are no current plans to replace this building as it is in full use and is relatively new. The scenarios presented in the case study are all hypothetical, meant to demonstrate the application of the concept in a potential real-life example.

The structural and architectural drawings were obtained from Facilities at the University of Ottawa campus. Information gathered in this report was obtained from various sources: the structural drawings, site visits to the building, Concrete Design Handbook, Handbook of Steel Construction, and the National Building Code of Canada.

5.2 Building Description

5.2.1 Location

The University of Ottawa's FSS Building is located centrally on its campus. The campus is located in the capital's downtown core at 120 University Private. Figure 5.1 shows the building from outside (reference the blue building); more images of the building from the outside and the inside can be found in Appendix C1.



Figure 5.1 The Faculty of Social Sciences Seen from the Outside (University of Ottawa, 2021)

5.2.2 Year Built

The FSS Building opened in October 2012. Construction spanned three years starting in 2009 and ending in 2012. The structural drawings, issued in 2008, show that the building was built as per Ontario Building Code 2006 (OBC 2006) which is based on the National Building Code of Canada 2005 (NBC 2005).

5.2.3 Use and Occupancy

The 15-storey building has a surface area of 25299 square metres, and it includes new and updated classrooms, a large multipurpose room, and an atrium with an iconic six-story living wall. The building is also connected to Vanier Hall, where the School of Psychology is located, by several walkways, bringing together the Faculty of Social Sciences' nine academic units (departments, schools, and an institute) as well as six research centres. The building houses the faculty's 10000 students, 260 professors, and 100 staff members under its roof.

5.3 Existing Building

5.3.1 View of Existing Building

The FSS Building structural drawings list consists of 53 files. In Figures 5.2 to 5.10, certain relevant screenshots of those drawings are shared to showcase the design of the existing building. In addition to the 15 floor plans provided in the files, there were also the basement and penthouse plans that were not considered as they are out of the scope of this chapter. The FSS Building is considered an irregular structure due to vertical stiffness, vertical geometric, and torsional irregularities as per OBC 2006 clause 4.1.8.6. This can be observed in the floor plans where floors 1-7, 8, 9-11, and 12-15 all have different floor layouts. In Figure 5.2, this variance can be seen from the outside as the sub-buildings can be noted to have different heights and designs. The building is mostly designed as a flat slab structure with the ground floor slab thickness being 275 mm while the rest of the slabs are 250 mm.

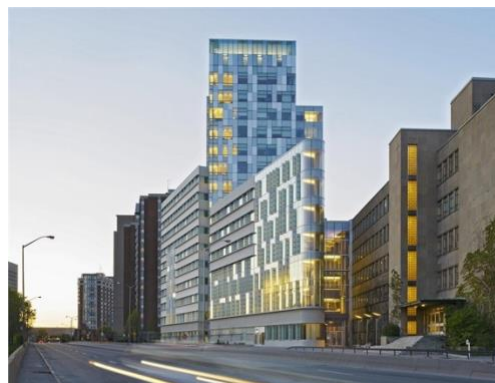

Figure 5.2 Closer View of the FSS Building (Canadian Architect, 2014)

Chapter 5: University of Ottawa Building Case Study

Figure 5.3, Figure 5.4, Figure 5.5, and Figure 5.6 show the west, north, east, and south building elevations respectively. The ground floor boasting the lobby can be observed to be taller than other floors with a storey-to-storey height of 5.25 m while floors 2-15 are 3.81 m each.

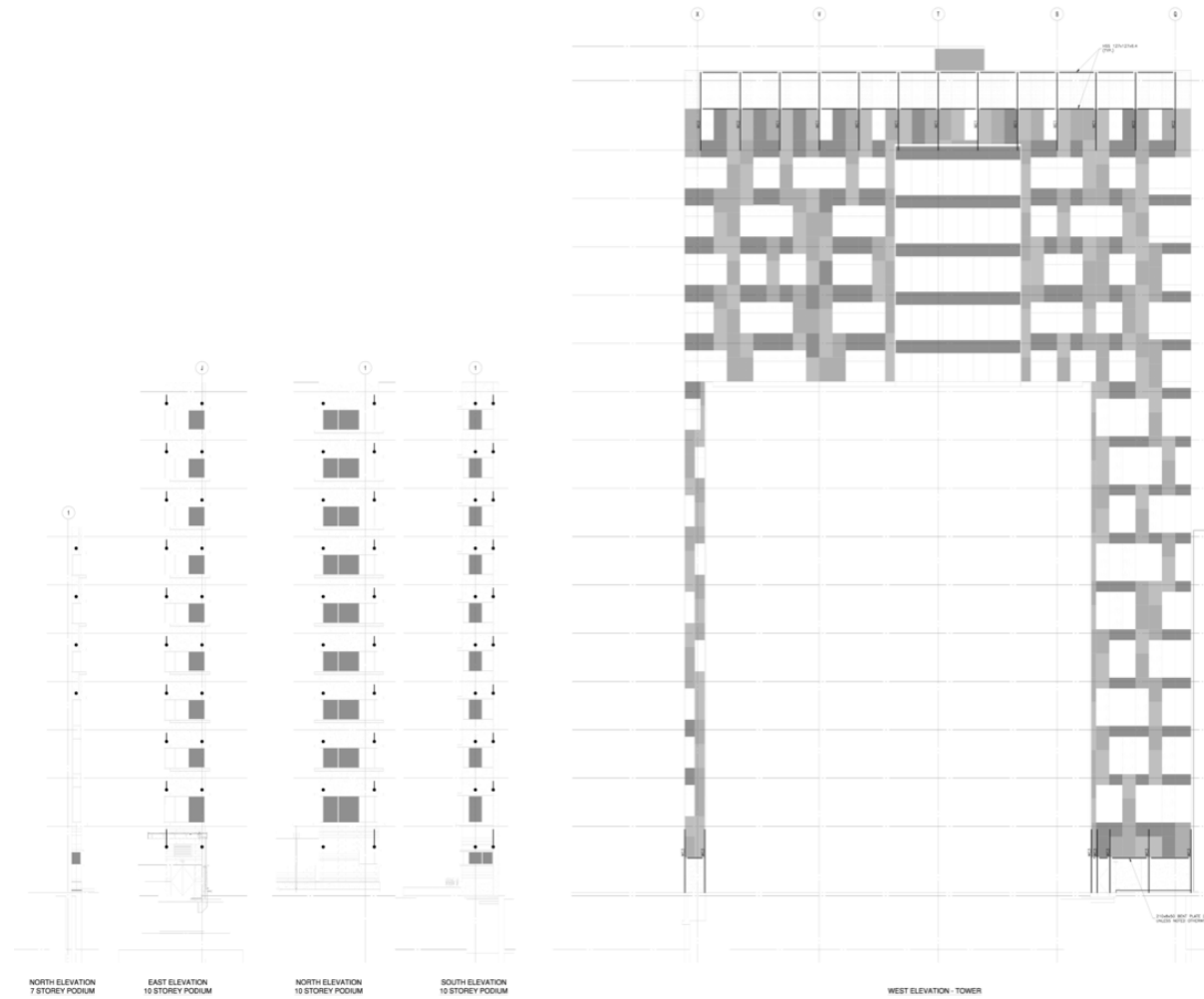

Figure 5.3 West Building Elevation



Figure 5.4 North Building Elevation

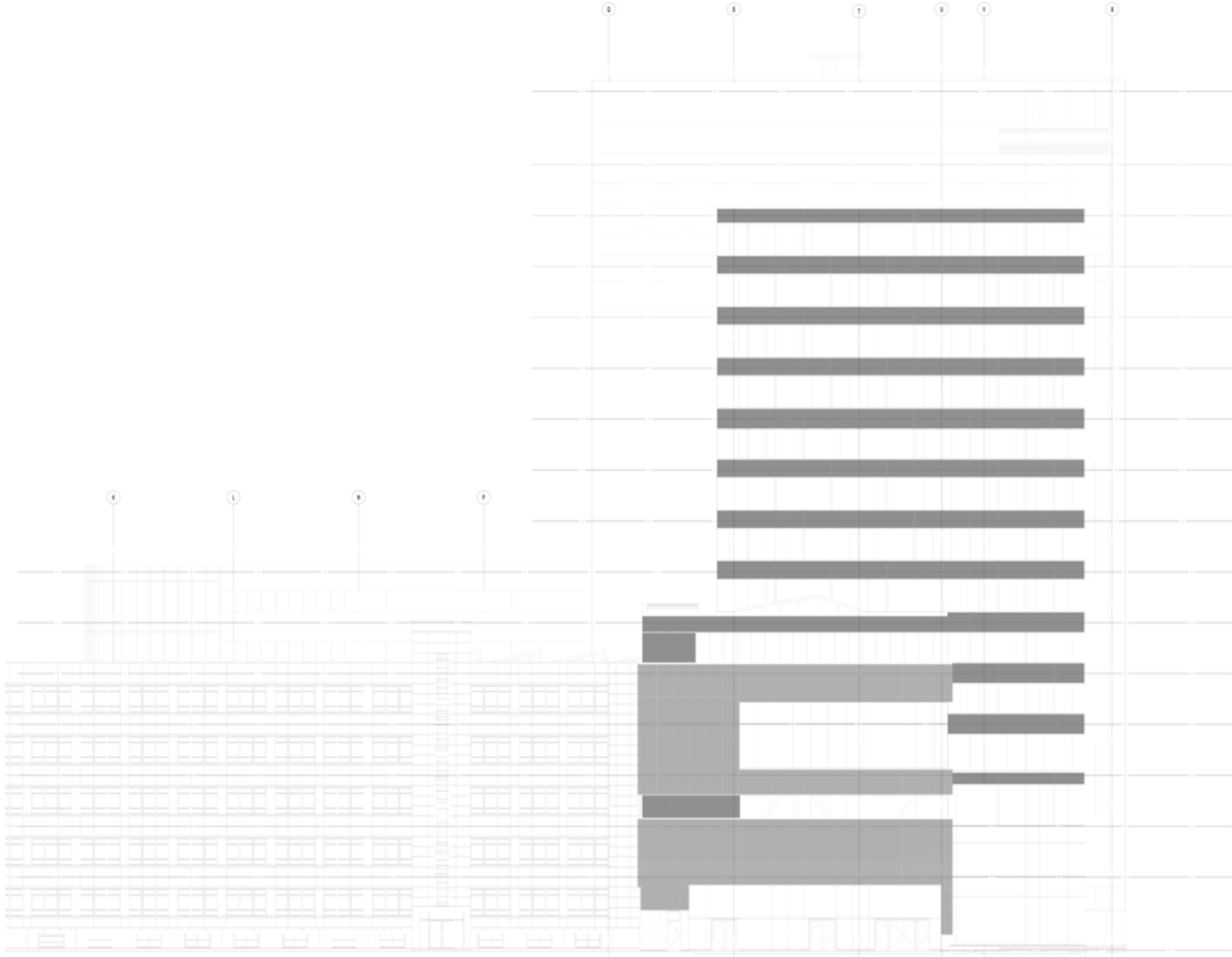

Figure 5.5 East Building Elevation

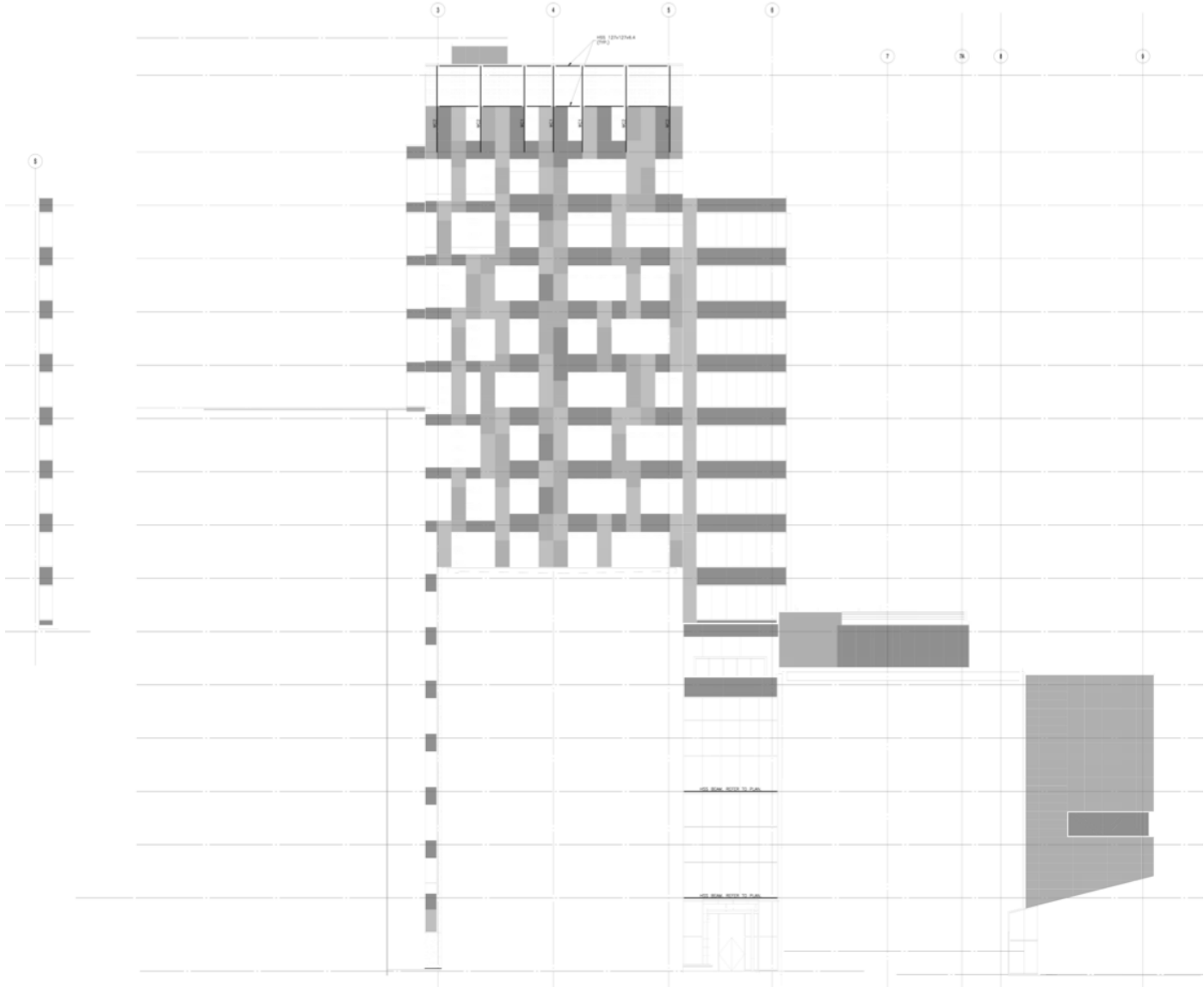

Figure 5.6 South Building Elevation

Figure 5.7, Figure 5.8, Figure 5.9, and Figure 5.10 show the ground, eighth, ninth, and twelfth floor framing plans, respectively. These floor plans are considered to be representative of the typical floor layouts throughout the building. The rest of the floor plans can be found in Appendix C2. Since there are many details present on the drawings that can be difficult to read, highlights were added to indicate the main features of the structure. The colour red is used to show the columns, blue is used to show the beams, green is used to show the staircases, and purple is used to show the elevators.



Figure 5.7 Ground Floor Framing Plan

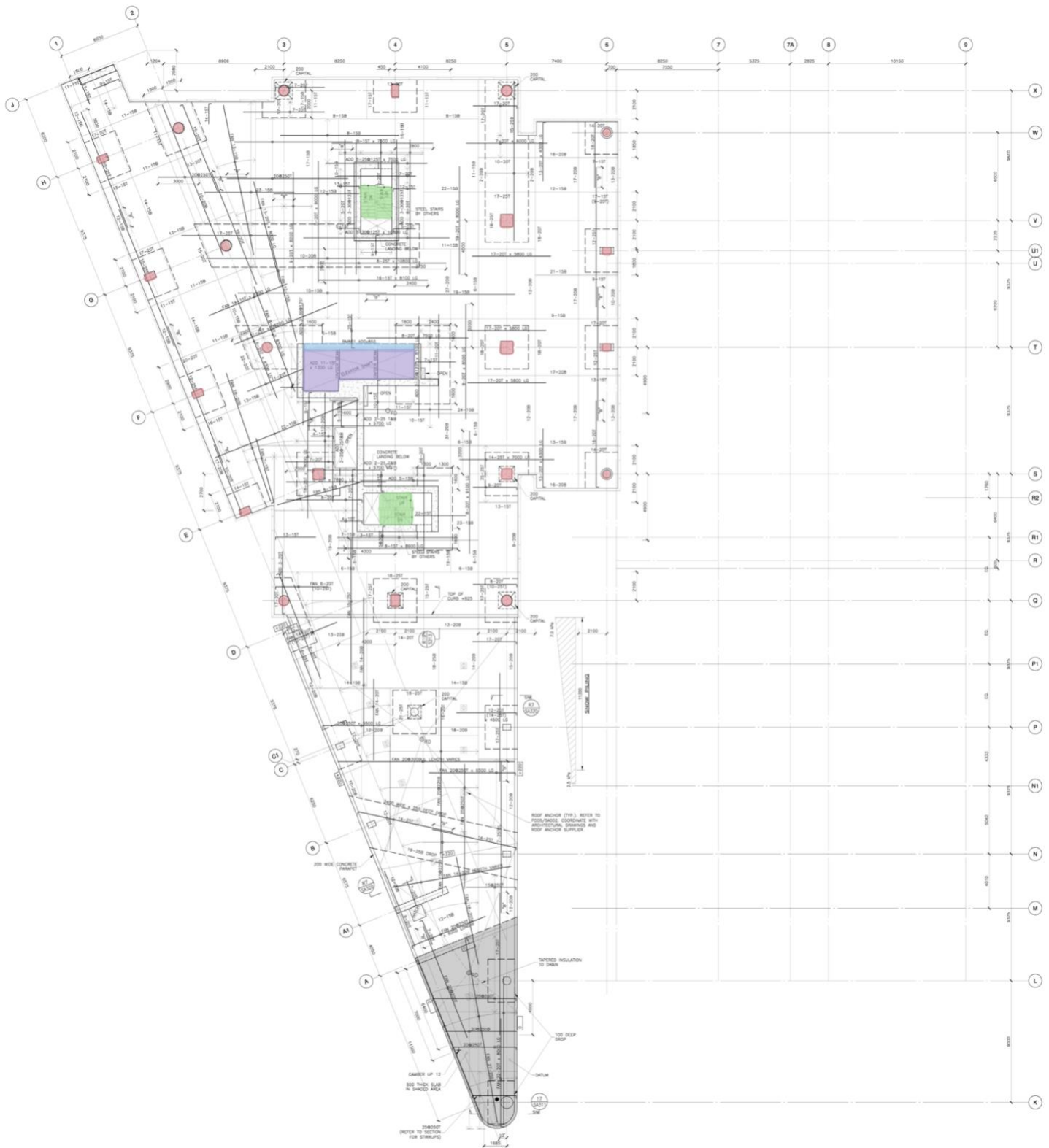

Figure 5.8 Eighth Floor Framing Plan

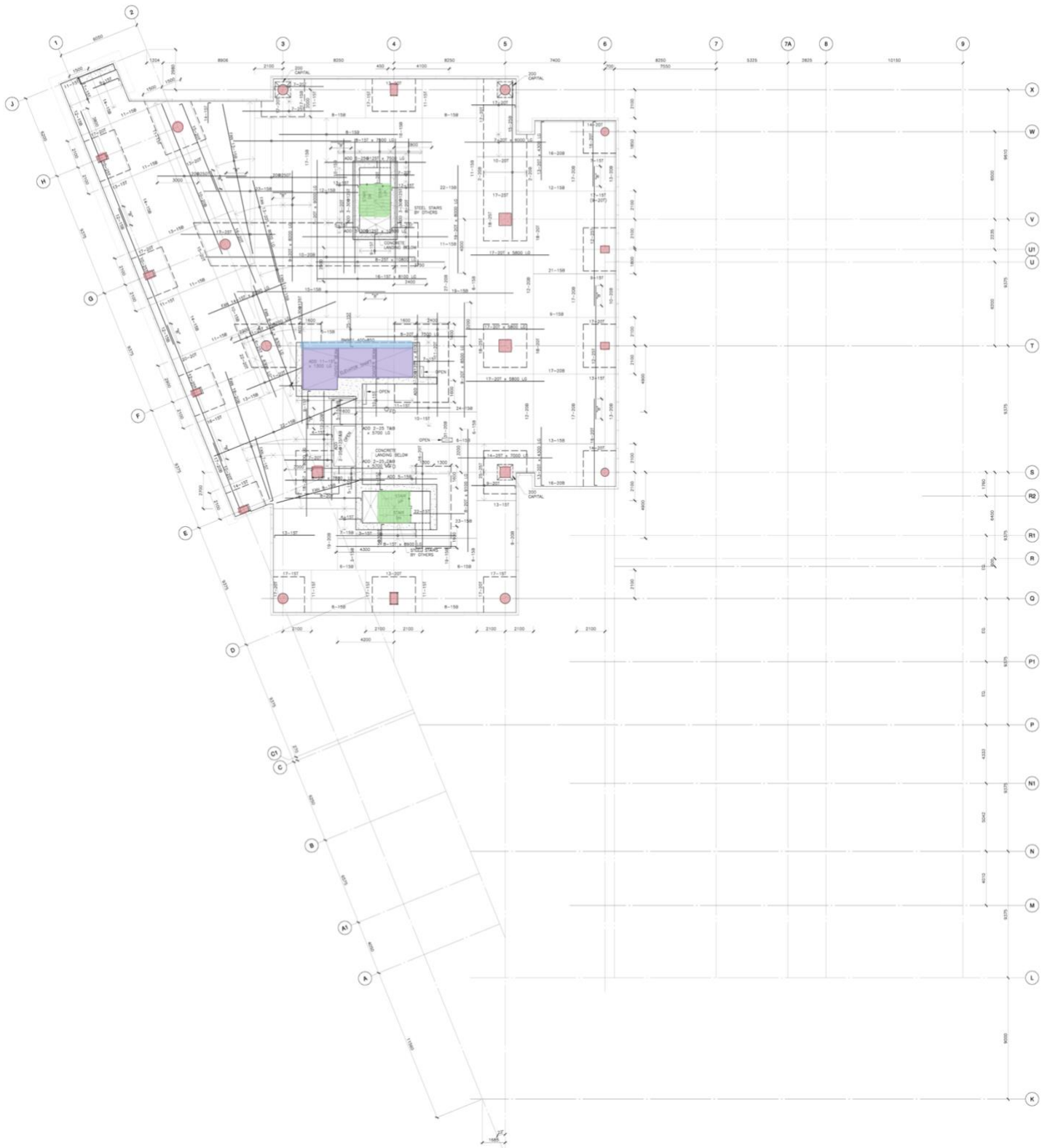

Figure 5.9 Ninth Floor Framing Plan

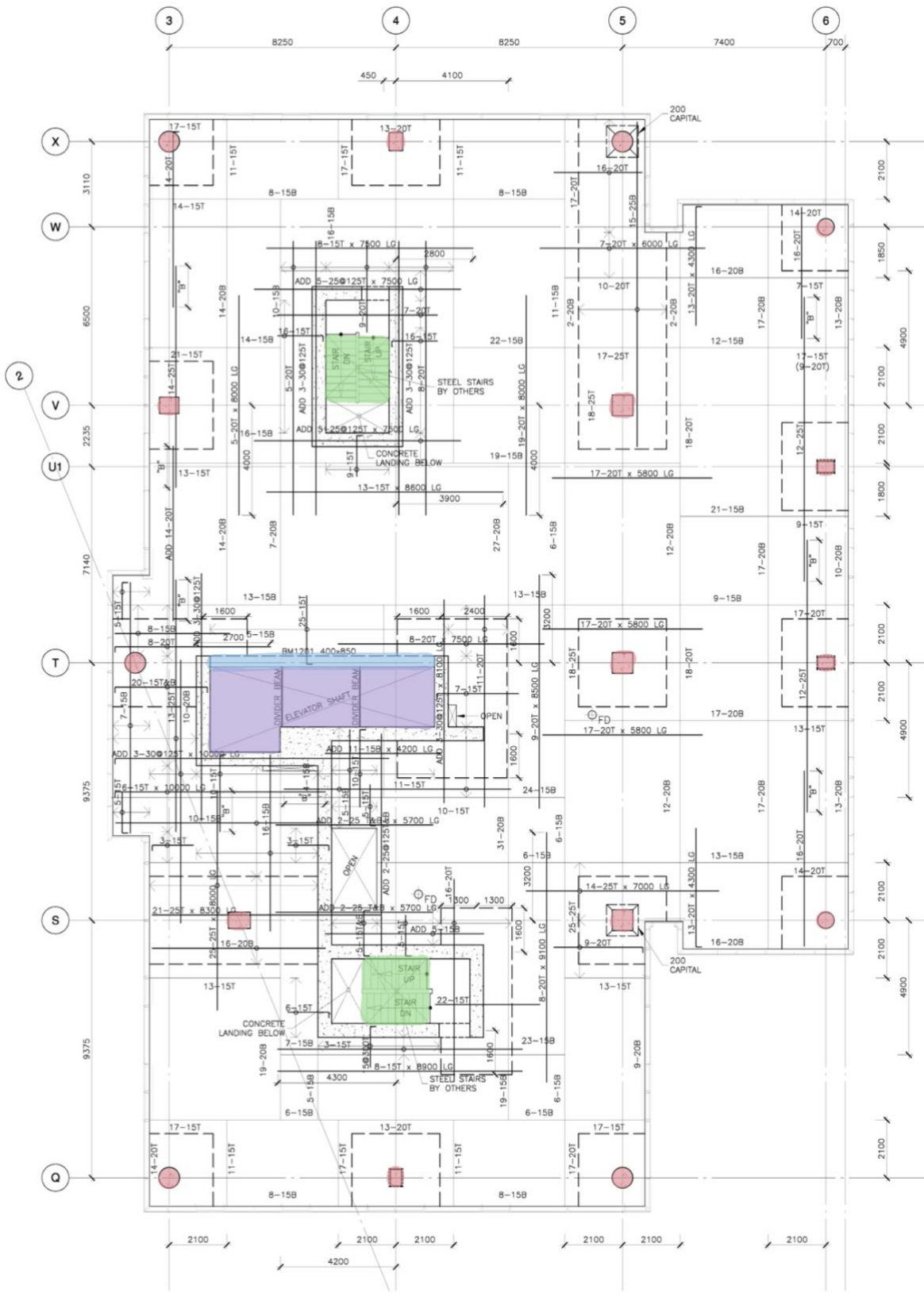

Figure 5.10 Twelfth Floor Framing Plan

5.3.2 Disassembly Plan of Existing Building

It is important to highlight that the scope of this case study solely covers the primary gravity load resisting frame (i.e., columns and slabs) and it will not address the lateral load resisting system. It is acknowledged that the integrity of the repurposed building and load path for lateral forces (e.g. wind or earthquake) is critical for design and will need to be addressed in future research. Beams – although part of the primary gravity load resisting frame – were not considered since this structure was mostly designed as a flat slab structure with minimal use of beams that were almost always varying in size and design, thus, not lending themselves to be very practical for reuse. Moreover, since the original structure is mainly a flat slab structure, the same approach will be used when designing the repurposed building.

As observed from the previous subsection, the building’s irregular shape and several openings makes it challenging to collect slab ‘pieces’ with regular or repeated geometry. However, certain areas in the various floor framing plans were observed to contain strips of slab ‘pieces’ that can be accessibly collected by mechanical cutting. A sample can be seen in Figure 5.11 showing a portion of the second-floor framing plan. The rectangles in red are the slab ‘pieces’ defined by parallel lines of columns. Note that the slabs will be cut near the face of the columns, leaving small “cut outs” at each of the four corners.



Figure 5.11 Strip of Slab ‘Pieces’ Retained from the Second Floor Framing Plan

Where possible, it was preferred to extract columns at lengths equivalent to at least two storeys (approximately 7.6 m tall). These column lengths are short enough to be easily transported and erected, while reducing the need to splice columns together in multistorey buildings. This also minimizes variations along the height of a single column in terms of reinforcement ratio and form factor. Figure 5.12 shows the design of a typical concrete column transition in the FSS Building. In addition to the changes in shape, the size, the reinforcement, the factored axial load, and/or the compressive strength of the concrete changed as well.

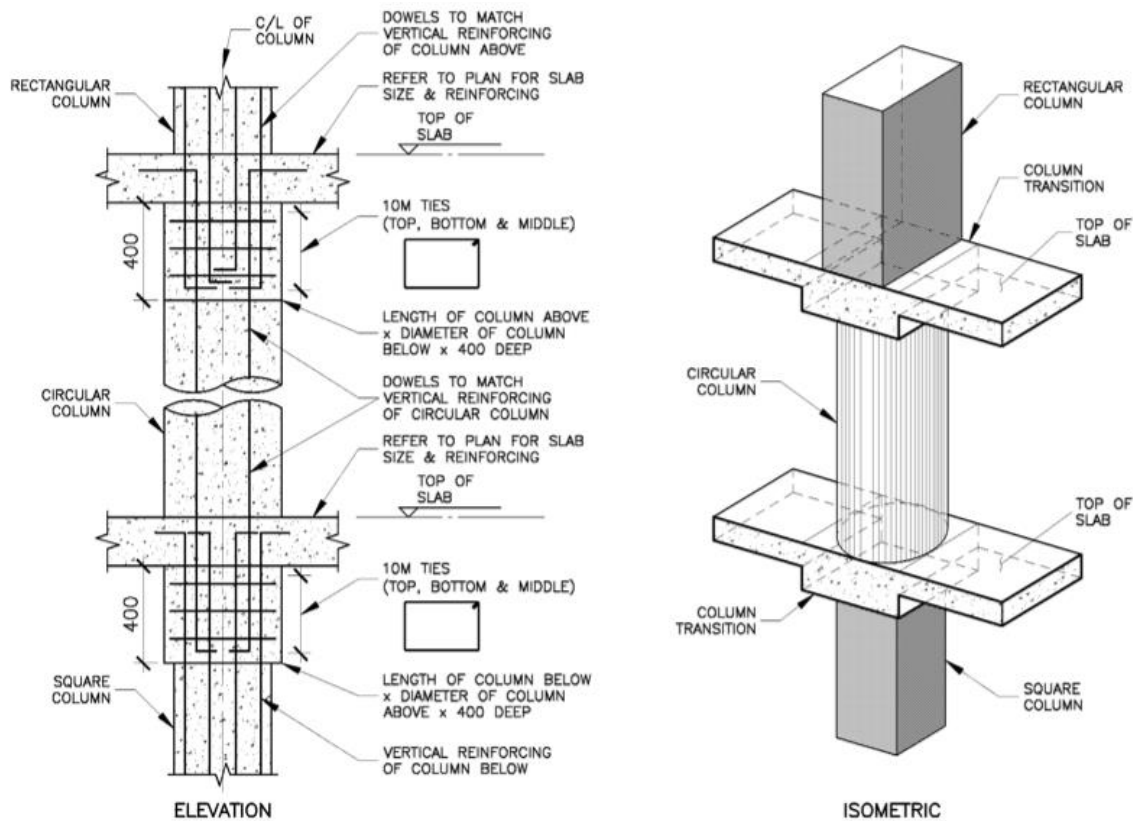

Figure 5.12 Typical Concrete Column Transition

The optimal column length depends on the intended application; for this case study, a hypothetical two-story structure will be considered. Hence, columns extending more than two storeys will be assumed to be cut cross-sectionally at every second floor.

5.3.3 Inventory of Reusable Building Components

In Table 5.1, an inventory of the concrete columns present in the structure is presented for circular, square, and rectangular columns. The building also makes use of some steel columns; however, since this study is focused on concrete reuse, they will not be considered. As observed in the table, there are many different column designs within the structure. They vary by type (e.g., circle, square, and rectangle), by size (e.g., for circular columns, they range from 600 mm to 1000 mm in diameter; for square columns, they range from 750x750 mm to 975x975 mm; and for rectangular columns, they generally range from 400x600 mm to 1100x500 mm), by reinforcement (e.g., from ten 20M bars to sixteen 30M bars, and a tie spacing ranging from 300 mm to 475 mm), by capacity (e.g., 2974 kN to 22000 kN), and by concrete compressive strength (e.g., from 25 MPa to 60 MPa).

Note that for circular columns, size denotes the diameter; for square and rectangular columns, size denotes the base and height. The steel reinforcement is described using a nomenclature system with four values (e.g., 10-20V 10@300). The first value denotes the number of longitudinal reinforcing bars, the second value denotes the nominal rebar diameter in millimeters, the third value denotes the nominal size of shear ties, and the fourth value denotes the spacing of the ties in millimetres. Hence, 10-20V 10@300 refers to a column with ten 20M vertical bars and 10M ties at a 300 mm spacing. Figure 5.13 shows the typical tie arrangements for concrete columns in the FSS Building.

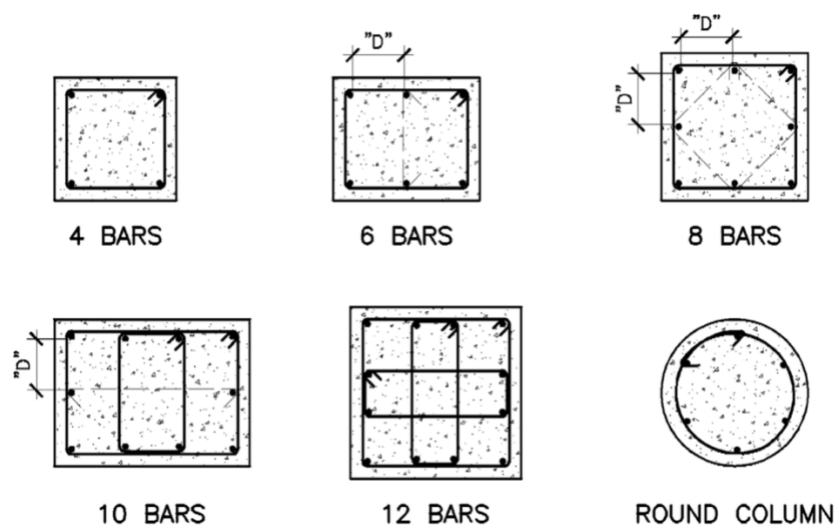

Figure 5.13 Typical Tie Arrangements for Concrete Columns in the FSS Building

Table 5.1 Column Inventory

Size (mm)	Reinforcement	Factored Axial Capacity (kN)	f'_c (MPa)	Length (m)	Quantity
600	10-20V 10@300	2974	25	3.81	2
600	10-20V 10@300	2974	25	7.62	2
600	12-25V 10@400	3116	30	3.81	2
600	12-25V 10@400	3116	30	7.62	4
600	12-25V 10@400	1394	35	7.62	2
600	12-20V 10@300	3849	35	7.62	2
750	12-25V 10@400	3976	25	7.62	10
750	12-25V 10@400	6900	30	7.62	12
750	12-25V 10@400	7493	35	3.81	1
750	12-25V 10@400	7493	35	7.62	2
750	12-25V 10@400	8923	45	7.62	1
850	12-25V 10@400	9808	35	3.81	7
850	12-25V 10@400	9808	35	7.62	14
900	12-30V 10@475	10934	35	3.81	5
900	12-30V 10@400	3445	35	7.62	2
900	12-30V 10@475	10934	35	7.62	4
900	12-30V 10@475	12433	45	5.25	13
900	12-30V 10@475	12433	45	7.62	17
900	12-30V 10@350	17028	60	5.25	1
900	12-30V 10@350	17028	60	7.62	3
900	12-30V 10@475	14100	60	7.62	2
1000	12-30V 10@475	12952	45	5.25	1
1000	12-30V 10@350	20377	60	7.62	1
750x750	12-30V 10@475	6259	25	7.62	3
750x750	12-30V 10@475	8863	30	7.62	5
750x750	12-30V 10@475	9346	35	3.81	1
750x750	12-30V 10@475	9346	35	7.62	1
800x800	12-30V 10@475	9707	30	3.81	1
800x800	12-30V 10@475	11345	35	3.81	1
800x800	12-30V 10@475	11345	35	7.62	1
800x800	12-30V 10@475	12847	45	5.25	2
900x900	16-30V 10@475	11779	30	7.62	2
900x900	16-30V 10@475	13156	35	3.81	3
900x900	16-30V 10@475	13156	35	7.62	1
900x900	16-30V 10@475	16130	45	5.25	1

Table 5.1 Continued

900x900	16-30V 10@475	16130	45	7.62	2
900x900	16-30V 10@475	14533	60	3.81	1
975x975	16-30V 10@350	21923	60	5.25	3
400x600	8-25V 10@400	2766	25	3.81	2
400x600	8-25V 10@400	2766	25	7.62	2
400x600	10-25V 10@400	2225	30	7.62	4
400x600	10-25V 10@400	2159	35	7.62	4
500x650	10-25V 10@400	5595	30	7.62	3
500x800	10-25V 10@400	3049	30	3.81	4
500x800	10-25V 10@400	5493	35	3.81	7
500x800	10-25V 10@400	5493	35	7.62	5
500x900	10-25V 10@400	6304	35	3.81	5
500x1000	10-30V 10@475	6328	35	3.81	1
500x1000	10-30V 10@475	6328	35	7.62	1
500x1000	10-30V 10@475	9179	45	5.25	5
500x1000	10-30V 10@475	9179	45	7.62	5
600x400	8-25V 10@400	2949	25	7.62	2
650x500	12-25V 10@400	3173	25	7.62	2
650x500	12-25V 10@400	3745	30	3.81	2
600x700	12-25V 10@400	3485	25	7.62	5
600x700	12-25V 10@400	3379	30	3.81	1
600x800	12-25V 10@400	5253	25	7.62	2
600x800	12-25V 10@400	6267	30	3.81	1
800x500	10-25V 10@400	4883	30	7.62	2
800x3500	56-25V 10@400	22000	45	5.25	1
900x500	10-25V 10@400	5451	30	3.81	1
900x600	10-30V 10@475	5227	30	3.81	1
1000x500	10-30V 10@475	7717	35	7.62	2
1000x500	10-30V 10@475	8432	45	3.81	1
1100x500	10-30V 10@475	9862	45	3.81	1
1100x500	10-30V 10@475	9862	45	5.25	1

In total, there are 132 columns extracted with a length of 7.62 m (spanning two floors), 28 columns at 5.25 m (spanning one ground floor), and 51 columns at 3.81 m (spanning one floor). This summary can be observed in Table 5.2. Note that ‘regular’ denotes floors above ground (i.e., floors 2-15 that are 3.81 m in elevation).

Table 5.2 Column Inventory Quick Summary

Description	Length (m)	Quantity
2 Floors (regular)	7.62	132
1 Floor (ground)	5.25	28
1 Floor (regular)	3.81	51

Table 5.3 shows the slab inventory retained from the structure. The FSS Building is irregularly shaped and contains many openings as shown in Figure 5.14. The irregular shape of the building makes it more challenging to cut uniform slab pieces and the many openings present in the building allow for less slab to be needed. As such, only 69 rectangular slab pieces are considered to be salvageable, as summarized in Table 5.3.

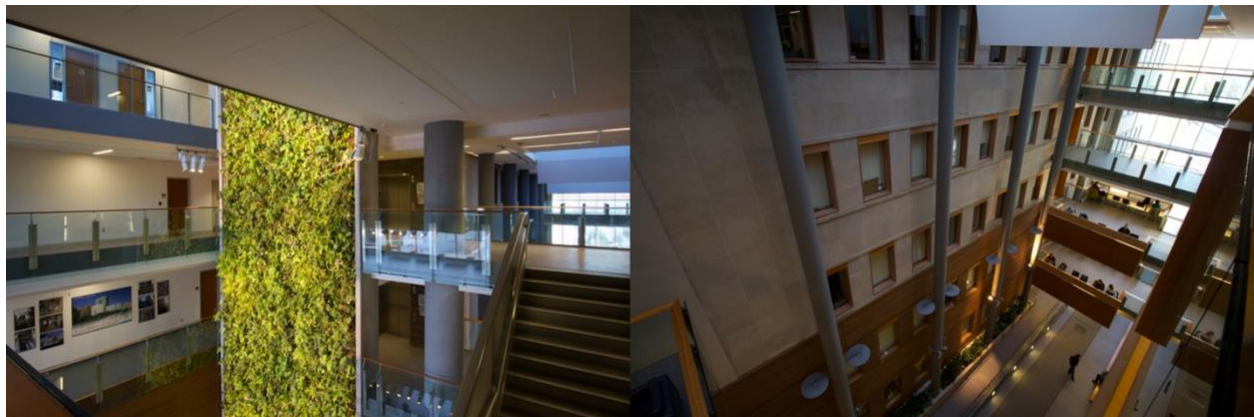

Figure 5.14 FSS Building from the Inside Showing the Floor Openings

Table 5.3 Slab Inventory

Length (m)	Width (m)	Thickness (mm)	f'_c (MPa)	Quantity
9.375	6.05	250	30	41
9.375	7.4	250	30	28

5.4 Repurposed Building

5.4.1 Proposed Geometry

Using the inventory presented in the previous section, a hypothetical building is proposed using the salvaged concrete structural components. Only a conceptual design of the primary gravity load resisting system is presented within the scope of this thesis. Detailing of connections, lateral load resisting system, and other features (e.g., foundation design, staircases, elevators, building enclosure, mechanical HVAC systems, etc.) are not considered. While the original building was designed as an assembly area to primarily contain offices and lecture halls, the redesigned building is proposed as a residential space for apartments. This is a conservative measure to lower the uniformly distributed live loading that will be experienced by the building. This significantly reduces the demand on the connections in the reassembled structure, which simplifies the design and construction process and introduces considerable cost savings.

The redesigned low-rise apartment complex will be two storeys high with a front lobby that is one-storey only. Figure 5.15 and Figure 5.16 show the first and second storey floor plans respectively. The elevation of the apartment complex will be 7.87 m while the elevation of the lobby will be approximately half of that at 4.06 m as seen in Figure 5.17 Elevation View of the Proposed Building. The length of the apartment complex will be 46.875 m and the width will be 26.9 m, while the lobby will be 28.125 m in length and 12.1 m in width. The building is expected to use 26 rectangular slab portions measuring 9.375 x 6.05 m and 20 slab portions measuring 9.375 x 7.4 m, for a total of 46 slab panels. With regards to columns, a total of 38 columns are needed, with 30 columns spanning two floors for the apartment complex and 8 columns spanning a single floor for the lobby. The 7.62 m long circular columns of diameters 850 mm and 900 mm were selected from the inventory for the 30 columns that need to be two-storey high. There are 42 of these columns available so this will allow for flexibility in selecting the final count of columns to be used in the redesign. The 3.81 m long circular columns also of diameters 850 mm and 900 mm were selected from the inventory for the 8 columns that need to be one-storey high in the lobby. There are 12 available from the inventory so there is also some flexibility in selection.

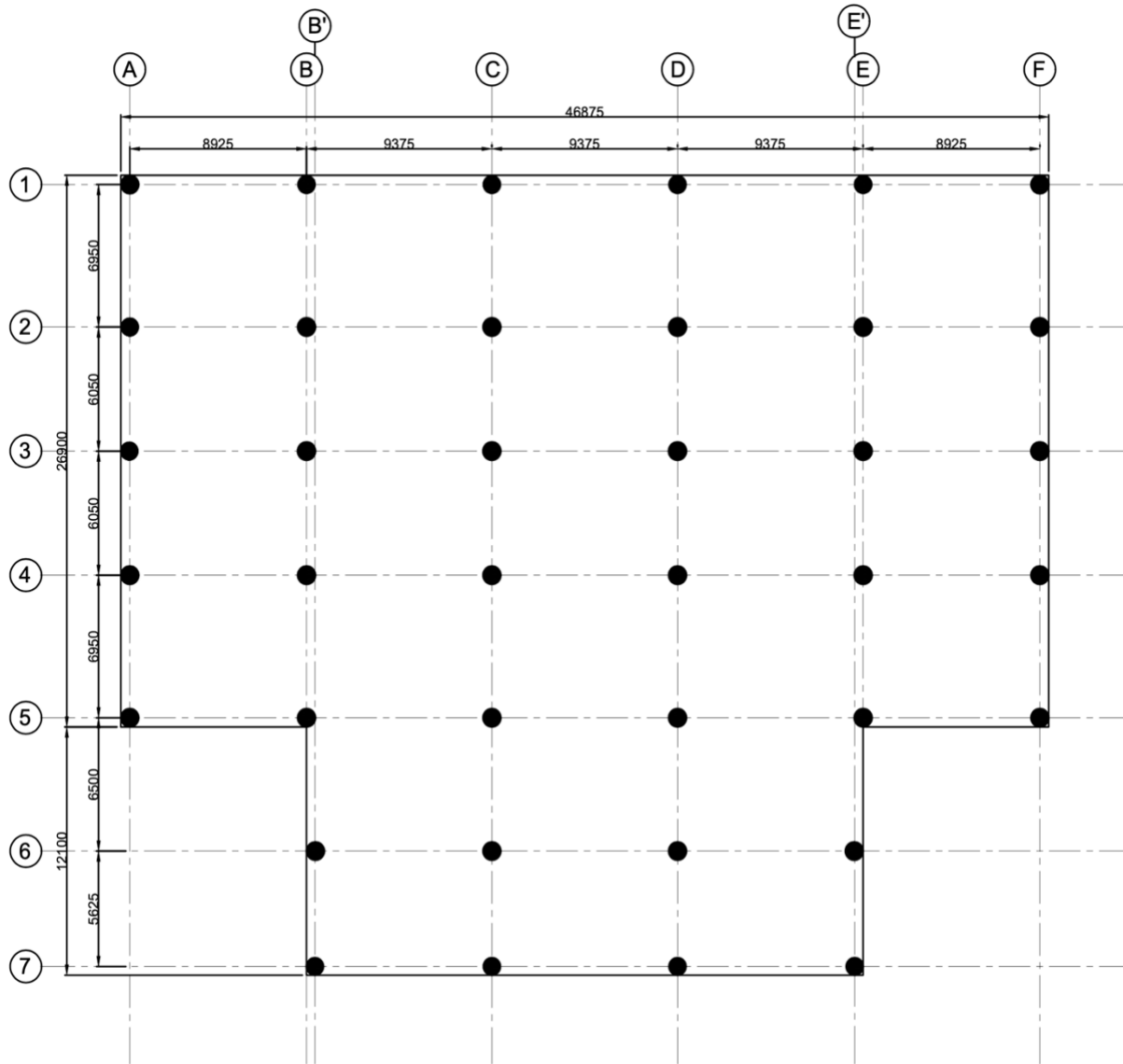

Figure 5.15 First Floor Plan of the Proposed Building

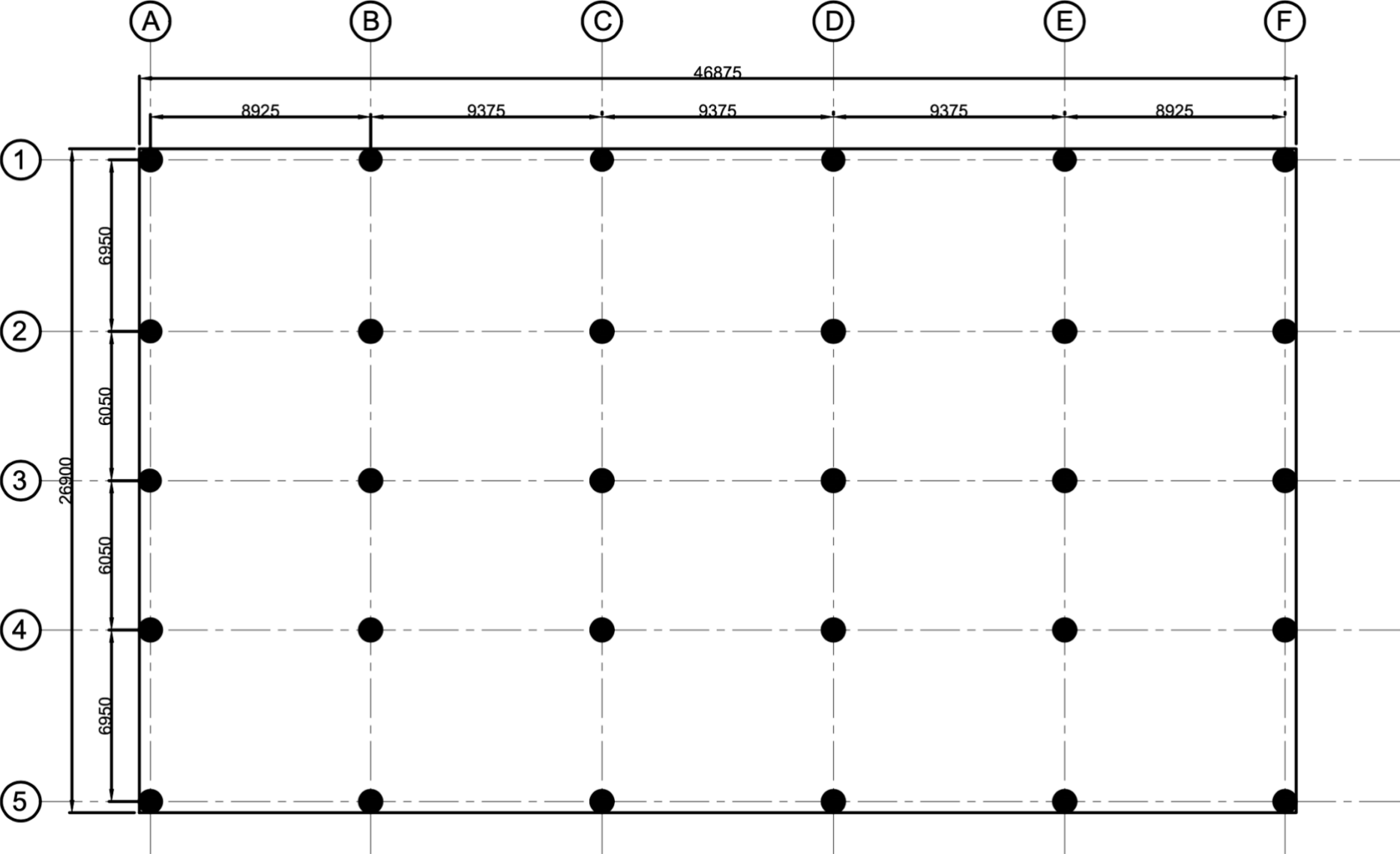

Figure 5.16 Second Floor Plan of the Proposed Building

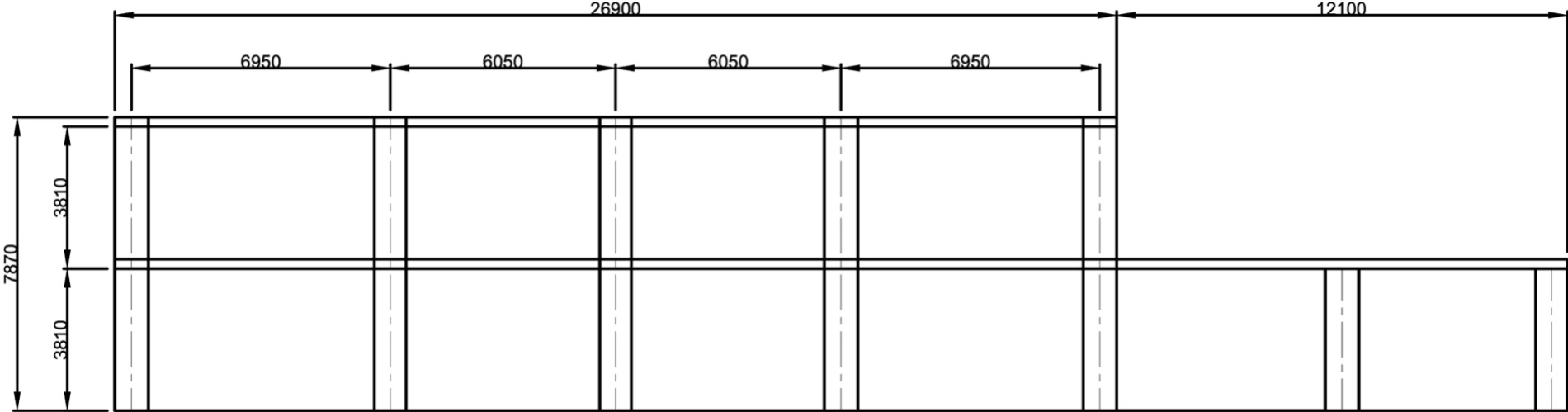

Figure 5.17 Elevation View of the Proposed Building

In Table 5.4, a summary of the percentage of reuse for each structural element type is showcased. Unlike the bridge where there were higher percentages of reuse achieved, the building had much lower proportion of reused structural components. This is mainly due to the complexity of the building plans in comparison to the bridge, as well as the reduced size of the repurposed building. The complexity of the building plans arises from its irregular floor layout that had a significant effect on the column and slab design, resulting in a relatively high degree of variation between individual components making it more challenging for reuse. As summarized below, 23% of the columns at 7.62 m length and 16% of the columns at 3.81 m length were used. This is in part due to the design of the new building which does not require as many columns but also due to the lack of slab pieces retained. With regards to the slab, the percentage reuse of the retained pieces was high at 71% and 63%. While it could be possible to make the redesigned structure slightly larger to reuse more columns and the rest of the slab pieces available, this was not done because it is a safer option to have some inventory remaining in case of any incurred damage that may require a replacement. The floor area of the repurposed building is 2862 m^2 while for the FSS Building it is 25299 m^2 , as mentioned earlier in 5.2.3. This means that the degree of reuse in terms of floor area is approximately 11.3%.

Table 5.4 Component Percentage Reused

Component	Measurements (m)	Quantity	Reused	Percentage Reused
Columns	7.62	132	30	23%
	5.25	28	0	0%
	3.81	51	8	16%
Slab	9.375x7.4	28	20	71%
	9.375x6.05	41	26	63%

5.4.2 Load Calculations

The uniformly distributed live load for a residential area is 1.9 kPa as specified in Table 4.1.5.3 of the NBC 2015. Self-weight load of the slabs is taken as 6 kPa using a thickness of 250 mm while the self-weight of a 900 mm diameter column is 58.2 kN per storey. An assumed superimposed dead load of 0.5 kPa is applied for partition walls and 1.0 kPa is applied for the flooring and

mechanical, thus, bringing the total superimposed dead load sustained to 1.5 kPa. Note that normal density concrete is used with a γ value equal to 24 kN/m³. Table 5.5 and Table 5.6 show the summary of these design loads for live and dead respectively. Environmental loads (e.g., snow and rain) are neglected for this simplified example.

Table 5.5 Design Live Loads

Load Type	Load (kPa)
Lobby + all living spaces	1.9

Table 5.6 Design Dead Loads

Load Type	Load
Column self-weight	58.3 kN
Slab self-weight	6 kPa
Partitions	0.5 kPa
Flooring + Mechanical	1.0 kPa

*Adjusted to include column self-weight.

Table 5.9 presents the total axial load due to live and dead loads on the ground floor interior, edge, and corner columns. Tributary areas for the interior, edge, and corner columns were calculated as 69.4 m², 34.7 m², and 17.3 m², respectively. Note that since there are two different slab piece sizes, the tributary areas were calculated based on the larger slab size. This was done to facilitate the design process for the more critical case which governed the design. The sum of dead loads in kN includes the self-weight of columns for two storeys (indicated with an asterisk).

Table 5.7 Gravity Load on Ground Floor Interior Columns

	Live Loads		Dead Loads	
	KPa	kN	KPa	kN
Storey 2	1.9	131.9	7.5	520.5
Storey 1	1.9	131.9	7.5	520.5
Σ	3.8	263.7	15.0	1157.6*

*Adjusted to include column self-weight.

Table 5.8 Gravity Load on Ground Floor Edge Columns

	Live Loads		Dead Loads	
	KPa	kN	KPa	kN
Storey 2	1.9	65.9	7.5	260.3
Storey 1	1.9	65.9	7.5	260.3
Σ	3.8	131.9	15.0	639.9*

*Adjusted to include column self-weight.

Table 5.9 Gravity Load on Ground Floor Corner Columns

	Live Loads		Dead Loads	
	KPa	kN	KPa	kN
Storey 2	1.9	32.9	7.5	129.8
Storey 1	1.9	32.9	7.5	129.8
Σ	3.8	65.7	15.0	375.9*

*Adjusted to include column self-weight.

In Table 5.10, the factored axial loads are calculated for interior, edge, and corner columns. Load combinations from cases 1 and 2 presented in Table 4.1.3.2.-A in NBC 2015 were used to find the governing factored load. For all three varying column locations, case 2 was the governing case.

Table 5.10 Factored Loads using Ultimate Limit State Load Combinations

Column Location	Case	Load Combination	Factored Load (kN)	Governing Case
Interior	1	1.4D	1620.4	
	2	1.25D + 1.5L	2066.0	✓
Edge	1	1.4D	895.9	
	2	1.25D + 1.5L	1124.7	✓
Corner	1	1.4D	526.3	
	2	1.25D + 1.5L	646.0	✓

To facilitate design and construction, the flat slabs will be simply supported on post-installed steel corbels connected to the columns. Therefore, the gravity loads are applied eccentrically with respect to the centroidal axis of the columns. In Table 5.11, the eccentricities of the columns depending on their location in the building are calculated. To calculate the value of the eccentricity, the radius of the larger column ($r = 450 \text{ mm}$) is added to the edge distance of the bearing seat dimension where the slab is supported (taken as 100 mm). Since there are edge columns about the north, south, east, and west sides of the building, they will experience eccentricity about different axes, with the north and south edge columns experiencing eccentricity about the y-axis while the east and west edge columns experiencing eccentricity about the x-axis. For the interior column, it is noted that the slabs are symmetrical about the x-axis, but they are not symmetrical about the y-axis; as such, the interior column will some experience some eccentricity about the y-axis due to this variation.

Table 5.11 Column Eccentricities

Column Location	Eccentricity about x-axis (m)	Eccentricity about y-axis (m)
Interior	0	0.05
Edge (N & S)*	0	0.55
Edge (E & W)*	0.55	0
Corner	0.55	0.55

“N & S” denote north and south

“E & W” denote east and west

In Table 5.12, column bending moments are shown. The values were calculated by multiplying the governing factored loads from Table 5.10 by the eccentricities from Table 5.11. As observed, the interior column experiences axial bending about the y-axis while the edge column experiences axial bending about the x-axis or y-axis depending on which edge it is located. The corner column experiences biaxial bending about both the x and y axes. In the final table column, the resultant moments for the three circular columns are calculated.

Table 5.12 Column Bending Moments

Column Location	Moment about x-axis (kN·m)	Moment about y-axis (kN·m)	Resultant Moment (kN·m)
Interior	0.0	103.3	103.3
Edge (N & S)*	0.0	618.6	618.6
Edge (E & W)*	618.6	0.0	618.6
Corner	355.3	355.3	502.5

“N & S” denote north and south

“E & W” denote east and west

The slabs have aspect ratios of approximately 1.5 and can be considered to be two-way slabs. In the initial analysis, it was assumed that the slabs are not continuous or supported along their edges; hence, code-based procedures for calculating critical design moments are not applicable. Instead, the yield line method was used. In this scenario denoted as ‘Option 1’ below, the larger slab piece of 7.4x9.375 m will govern the calculation as it will provide a more critical response. Note that the slab is simply supported in four corners, hence it only experiences positive moment. Although the slab is being examined as a potential two-way slab, the governing failure mechanism is actually a one-way failure mechanism with the positive yield line running vertically down the center, as illustrated in Figure 5.18. Equation 5.1 provides the equation for internal work while Equation 5.2 provides the equation for external work.

Option 1

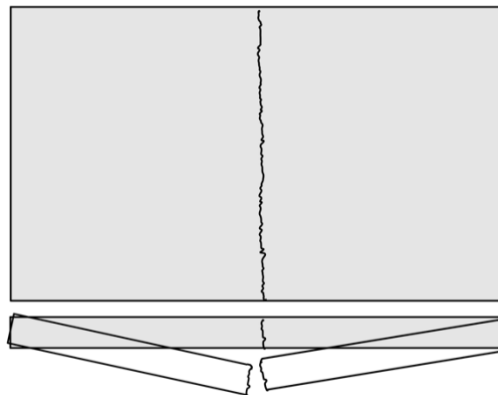

Figure 5.18 Yield Line Pattern for Option 1

$$Internal\ Work = \sum m_b l \theta \quad \text{Equation 5.1}$$

m_b : Bending moment per unit length of yield line

l : Length of the yield line

θ : Angle change at that yield line corresponding to the virtual displacement δ

$$Internal\ Work = M_n \times 7.4\ m \times \frac{1}{4.7\ m} = 1.57\ M_n$$

$$External\ Work = \sum \iint w \delta\ dx\ dy = \sum W \delta A \quad \text{Equation 5.2}$$

w : Uniformly distributed load on an element of area

δ : Deflection of that element

W : Total load of a plate segment

A : Area of that element

The principal of virtual work states that for conservation of energy, external work will be equal to internal work as observed in Equation 5.3.

$$\sum m_b l \theta = \sum W \delta A \quad \text{Equation 5.3}$$

$$External\ Work = (12.04\ KPa)(4.7\ m \times 7.4\ m) \left(\frac{1}{2}\right) = 209.37\ kN \cdot m/m$$

$$1.57\ M_n = 209.37\ kN \cdot m/m$$

$$M_n = 133.36\ kN \cdot m/m$$

Since the moment resistance of the slab (calculated in the following section) is not able to sustain this moment demand, another option has to be developed that allows for the development of negative moments around the slab edges. Therefore, the adjacent slab segments must be made continuous through moment connections along their edges that will be discussed later. The modified yield line pattern for this option is illustrated in Figure 5.19.

Option 2

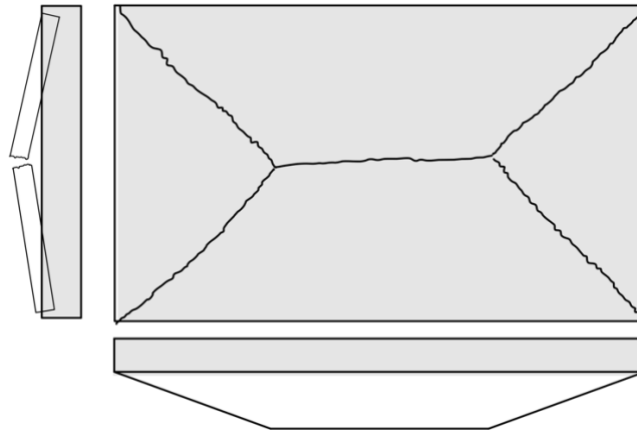

Figure 5.19 Yield Line Pattern for Option 2

In this option, the gaps in between adjacent slab panels will be filled with grout and an FRP layer will be placed on top to achieve a continuous slab failure mechanism (developing negative bending moment at the connection). It should be mentioned that FRP materials do not exhibit a defined yield plateau and hence the yield line method, based on plasticity theory, is technically invalid; however, studies have suggested that an equivalent plastic moment capacity based on the energy method can provide an analogous response to the conventional yield line approach (Gar et al. 2014).

$$Internal\ Work = \left(M_n \times 9.375 \times \frac{1}{3.7} \right) \times 2 + \left(M_n \times 7.4 \times \frac{1}{3.7} \right) \times 2 = 13.4 M_n$$

$$External\ Work = 12.04 \left(\frac{3.7 \times 3.7}{2} \times \frac{1}{3} \times 4 + 1.975 \times \frac{1}{2} \times 2 + \frac{3.7 \times 7.4}{2} \times \frac{1}{3} \times 2 \right)$$

$$= 243.5\ kN \cdot m/m$$

$$13.4 M_n = 243.5 \text{ kN} \cdot \text{m}/\text{m}$$

$$M_n = 18.2 \text{ kN} \cdot \text{m}/\text{m}$$

5.4.3 Capacity Calculations

Two concrete structural components are being reused in this redesign, namely columns and slabs. Both were more heavily loaded in their original configuration in the FSS Building; nevertheless, their capacities are checked here to compare with the applied factored loads. In the following subsections, the capacities for the smaller column diameter of 850 mm and slab size of 9.375x6.05 m are calculated.

5.4.3.1 Column Capacity

The maximum factored axial load resistance, $P_{r,max}$, of compression members is found using Equation 5.4 and Equation 5.5 below. These two equations originate from CSA A23.3-19 Design of Concrete Structures, section 10.10.4, equations 10.11 and 10.9 respectively.

$$P_{ro} = \alpha_1 \phi_c f'_c (A_g - A_{st} - A_t - A_p) + \phi_s f_y A_{st} + \phi_s F_y A_{st} - \phi_a F_y A_t - f_{pr} A_p \quad \text{Equation 5.4}$$

P_{ro} : Factored axial load resistance at zero eccentricity

α_1 : Ratio of average stress in rectangular compression block to the specified concrete strength

ϕ_c : Resistance factor for concrete

f'_c : Specified compressive strength of concrete

A_g : Gross area of section

A_{st} : Area of reinforcement in tension tie

A_t : Area of one leg of closed transverse torsion reinforcement

A_p : Area of prestressing tendons

ϕ_s : Resistance factor for non-prestressed reinforcing bars

f_y : Specified yield strength of non-prestressed reinforcement or anchor steel

F_y : Specified yield strength of structural steel section

ϕ_a : Resistance factor for structural steel

f_{pr} : Stress in prestressing tendons at factored resistance

$$P_{ro} = (0.80)(0.65)(35 \text{ MPa})(5.67 \times 10^5 \text{ mm}^2 - 6000 \text{ mm}^2) \\ + (0.85)(400 \text{ MPa})(6000 \text{ mm}^2)$$

$$P_{ro} = 12258 \text{ kN}$$

$$P_{r,max} = (0.2 + 0.002h)P_{ro} \leq 0.80P_{ro}$$

Equation 5.5

$P_{r,max}$: Maximum axial load resistance calculated

h : Wall thickness or the minimum column dimension

$$P_{r,max} = 0.80(12258 \text{ kN})$$

$$P_{r,max} = 9807 \text{ kN}$$

The maximum axial load resistance of the 850 mm diameter circular concrete column is 9807 kN. This value matches what was provided in the concrete column schedule in the drawing which can be found in Table 5.1.

Another important metric to check with regards to column capacity is the moment resistance. This was done using the interaction diagrams in Chapter 7: Additional Design Aid from the Concrete Design Handbook. Again, the column diameter of 850 mm was used for the calculation as it was

the smaller column. With an actual γ value of 0.85, the interaction diagram corresponding to $\gamma = 0.80$ shown in Figure 5.20 will provide a conservative approximation.

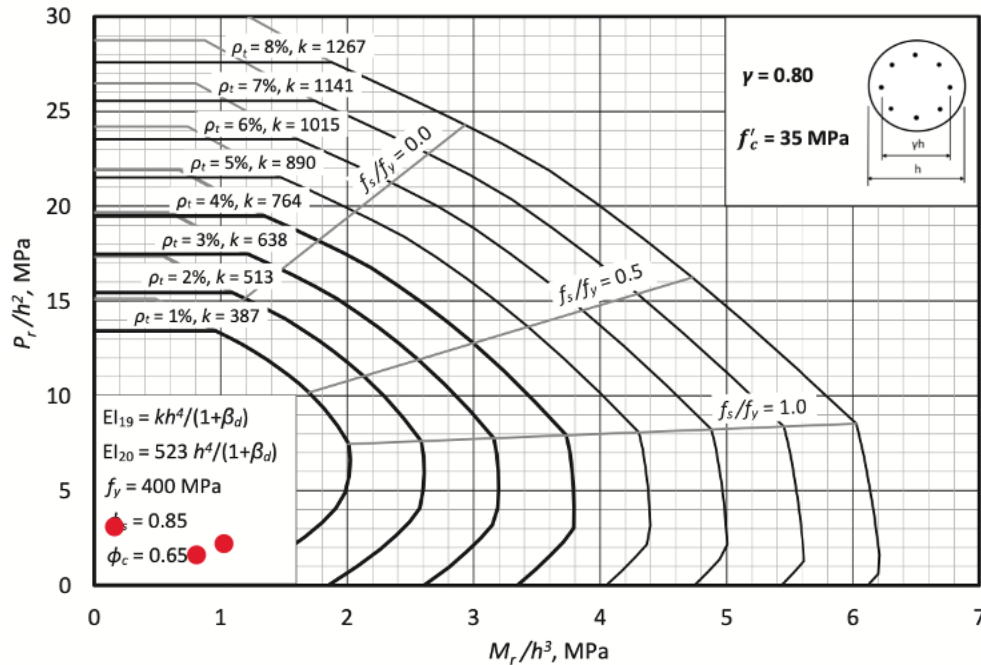

Figure 5.20 Table 7.13.7 Circular Tied or Spiral Columns

Table 5.13 provides the summary of the factored axial load and the resultant moment for all column locations. The reinforcement ratio for the column is found using Equation 5.6 based on the 850 mm column size.

Table 5.13 Summary of Factored Axial Load and Resultant Moment

Column Location	Factored Axial Load (kN)	Resultant Moment (kN·m)
Interior	2066.0	103.3
Edge	1124.7	618.6
Corner	646.0	502.5

$$\rho = \frac{A_s}{A_g}$$

Equation 5.6

ρ : Ratio of non-prestressed reinforcement

$$\rho = \frac{(6000 \text{ mm})^2}{\pi \times (425 \text{ mm})^2} = 1.01\%$$

$$\frac{P_r}{h^2} = \frac{1124.7 \times 10^3 \text{ N}}{(850 \text{ mm})^2} = 1.56$$

$$\frac{M_r}{h^3} = \frac{618.6 \times 10^6 \text{ kN} \cdot \text{m}}{(850 \text{ mm})^3} = 1.01$$

Using the coordinates of 1.56 and 0.96 in Figure 5.20 for $\gamma = 0.80$, it is observed that the point they produce is well within the interaction diagram for the 1% reinforcement ratio. The points can be seen plotted in red on the diagram. A summary for the checks is done below in Table 5.14 for all column locations.

Table 5.14 Moment Capacity Check for all Column Location

Column Location	$\frac{P_r}{h^2}$	$\frac{M_r}{h^3}$	Check within Curve
Interior	2.86	0.17	✓
Edge	1.56	1.01	✓
Corner	0.89	0.82	✓

5.4.3.2 Slab Capacity

With regards to the slab, shear and moment capacity checks were conducted. Equation 5.7 is used to compute the shear perimeter for punching shear near the column supports. Then, the shear area is calculated with Equation 5.8. Equation 5.9 is used to find the total shear force which is then inputted in Equation 5.10 to calculate the shear stress. Equation 5.11 and Equation 5.12 are used to find the critical punching shear resistance. Equation 5.13 is used to find the cracking force, Equation 5.14 is used to find effective shear depth, and Equation 5.15 is used to find the factor accounting for shear resistance of cracked concrete. Finally, with Equation 5.16 the shear resistance of the slab is calculated, which proves to be safe upon comparison to the factored shear force.

$$b_o = \left(d_c + \frac{d}{2} + \frac{d}{2} \right) \pi \quad \text{Equation 5.7}$$

b_o : Perimeter of critical section for shear in slabs

d_c : Distance from extreme tension fibre to centre of the longitudinal bar or wire located closest to it

$$b_o = \left(850 \text{ mm} + \frac{215}{2} + \frac{215}{2} \right) \pi = 3346 \text{ mm}$$

$$A_v = b_o d \quad \text{Equation 5.8}$$

$$A_v = (3346 \text{ mm})(215 \text{ mm}) = 720 \times 10^3 \text{ mm}^2$$

$$V_f = w_f A_{Trib} \quad \text{Equation 5.9}$$

A_{Trib} : Tributary area

$$V_f = (12.04 \text{ kPa}) \left((9.375 \times 7.4) - \frac{\pi(1.065)^2}{4} \right) = 824.5 \text{ kN}$$

$$v_f = \frac{V_f}{A_v} \quad \text{Equation 5.10}$$

v_f : Factored shear stress

$$v_f = \frac{824.5 \times 10^3 \text{ N}}{720 \times 10^3 \text{ mm}^2} = 1.15 \text{ MPa}$$

$$v_r = v_c = \left(\frac{\alpha_s d}{b_o} + 0.19 \right) \phi_c \sqrt{f'_c} \quad \text{Equation 5.11}$$

v_c : Factored shear stress resistance provided by the concrete

α_s : Factor that adjusts v_c for support dimensions

$$v_r = v_c = \left(\frac{2(215 \text{ mm})}{3346 \text{ mm}} + 0.19 \right) (0.65) \sqrt{30 \text{ MPa}} = 1.27 \text{ MPa}$$

$$v_r = v_c = 0.38 \phi_c \sqrt{f'_c} \quad \text{Equation 5.12}$$

$$v_r = v_c = 0.38(0.65) \sqrt{30 \text{ MPa}} = 1.35 \text{ MPa}$$

$$v_r = v_c = 1.27 \text{ MPa (governs)}$$

$$v_r > v_f = 1.15 \text{ MPa} \therefore \text{Safe}$$

$$f_{cr} = 0.4 \sqrt{f'_c} \quad \text{Equation 5.13}$$

f_{cr} : Cracking strength of concrete

$$f_{cr} = 0.4 \sqrt{30 \text{ MPa}} = 2.2 \text{ MPa}$$

$$d_v = \text{larger of } 0.9d \text{ and } 0.72h \quad \text{Equation 5.14}$$

d_v : Effective shear depth, taken as the greater of 0.9d or 0.72h

$$d_v = 0.9(212.4 \text{ mm}) \text{ or } 0.72(250 \text{ mm}) = 191.2 \text{ mm}$$

$$\beta = \frac{230}{1000 + d_v} \quad \text{Equation 5.15}$$

β : Factor accounting for shear resistance of cracked concrete

$$\beta = \frac{230}{1000 + 191.2 \text{ mm}} = 0.193$$

$$V_c = 2.5\beta\phi_c f_{cr} b_w d_v \quad \text{Equation 5.16}$$

V_c : Shear resistance attributed to the concrete factored by ϕ_c

b_w : Minimum effective web width

d_v : Effective shear depth, taken as the greater of $0.9d$ or $0.72h$

$$V_c = 2.5(0.193)(0.65)(2.2 \text{ MPa})(1000 \text{ mm})(191.2 \text{ mm}) = 131.9 \text{ kN/m}$$

$$V_f = (12.04 \text{ kPa}) \left(\frac{9.375 \times 7.4}{2(7.4)} \right) = 56.4 \text{ kN/m} < V_c \therefore \text{Safe}$$

Shear due to factored loads is less than the shear resistance, as such, the slab is safe.

To find the moment resistance in the slab, d , α_1 , and a are computed first using Equation 5.17, Equation 5.18, and Equation 5.19 respectively. Then, Equation 5.20 is used to calculate the moment resistance of the slab.

$$d = h - \text{cover} - \frac{d_b}{2} \quad \text{Equation 5.17}$$

d_b : Diameter of bar, wire, or prestressing strand

$$d = 250 \text{ mm} - 25 \text{ mm} - \frac{25.2 \text{ mm}}{2} = 212.4 \text{ mm}$$

$$\alpha_1 = 0.85 - 0.0015f'_c \quad \text{Equation 5.18}$$

$$\alpha_1 = 0.85 - 0.0015f'_c = 0.85 - 0.0015(30 \text{ MPa}) = 0.81$$

$$a = \frac{A_s \phi_s f_y}{\alpha_1 \phi_c f'_c b} \quad \text{Equation 5.19}$$

a: Depth of the equivalent rectangular stress blocks

b: Width of member

$$a = \frac{(800 \text{ mm}^2)(0.85)(400 \text{ MPa})}{(0.81)(0.65)(30 \text{ MPa})(1000 \text{ mm})} = 17.2$$

$$M_r = A_s \phi_s f_y \left(d - \frac{a}{2} \right) \quad \text{Equation 5.20}$$

A_s: Area of longitudinal reinforcement on the flexural tension side of the member

d: Effective depth

$$M_r = (800 \text{ mm}^2)(0.85)(400 \text{ MPa}) \left(212.4 \text{ mm} - \frac{17.2}{2} \right) = 55.4 \text{ kN} \cdot \text{m/m} > M_f \therefore \text{Safe}$$

Moment due to factored loads is less than the moment resistance presented in option 2, as such, the slab is safe.

In the previous chapter, where a bridge was the subject of the case study, a 25% reduction factor was placed on the capacity of the structural members being reused. In this case study, no reduction factor is introduced. This in part because many conservative approaches were taken in the calculations of the factored moment and shear resistance, but it is also due to the fact that since this is a building, its structural members being reused are located internally where they are not exposed to environments that promote deterioration in their current life and in their reused life.

Therefore, there is less need for a reduction factor for the enclosed building components. In contrast, the bridge elements, being external, are exposed to potentially harsh environments that can stimulate corrosion and faster degradation.

5.4.4 Reassembly Plan of Repurposed Building

With the repurposed building plans defined in 5.4.1, this section will be focused on exploring the design of connections. The following questions were pondered:

1. How will the columns be fixed to the foundation?
2. How will the slabs be connected to the column?
3. How will the slabs be made continuous with each other?

Thus, the need for three different connection design categories emerged: a column-foundation connection, column-slab connection, and slab-slab connection. Note that designing the column-column splice connection is not necessary since the columns used in the redesigned building span two floors which simplifies the design process.

In the subsections below, these design categories are discussed in detail.

5.4.4.1 Column-Foundation Connection Design

For the column-foundation connection, five different design approaches were considered. Option 1 details drilling in dowels into the bottom of the column that would be inserted into the foundation block (i.e., into the footing). Option 2 involves chipping away at the concrete that is at the bottom of the column to reach the steel so that it is possible to splice the reinforcing steel in the column to the steel coming up from the support. Then, new concrete could be cast around it to seal it in. Option 3 requires drilling horizontal dowels in the bottom of the column from each side and then tying that in the reinforcement of the footing and casting concrete around it (i.e., anchoring the dowels in the footing reinforcement). Option 4 is embedding a substantial portion of the column into the footing and essentially casting the footing around it. Option 5 requires using a steel bracket that would be bolted down into the foundation. Figure 5.21 (a), (b), (c), and (d), showcase options 1, 2, 3, and 4, respectively, while Figure 5.22 shows option 5.

Considering these various approaches, option 5 was selected as the preferred option. While this option is easier from a constructability perspective, it will use some floor space and potentially impede the users. However, the design can be encapsulated with drywall to make it more aesthetically and architecturally pleasing. Using a threaded rod with a nut that is tightened and can be untightened along with a steel bracket that can be removed and disassembled is one of the goals of this case study. There is a need for adaptable and reconfigurable approaches and this design lends itself to that. One of the drawbacks of options 2, 3, and 4, is losing height from the column by chipping away at the column or embedding the column in the foundation. The design connection in option 4 will be a connection that is difficult to disconnect and disassemble, thus being an unfavourable option. The same can be noted for connection options 1, 2, and 3 although they are not as problematic in terms of dismantlement.

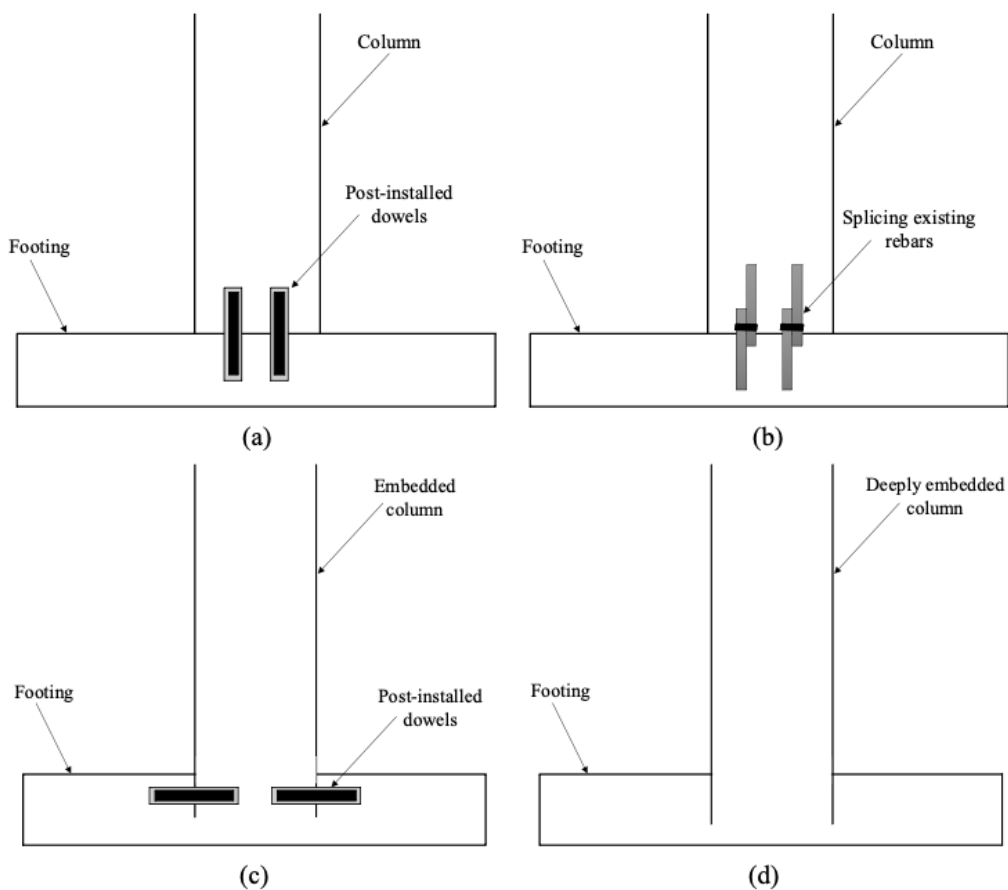

Figure 5.21 Column-Foundation Connection Options

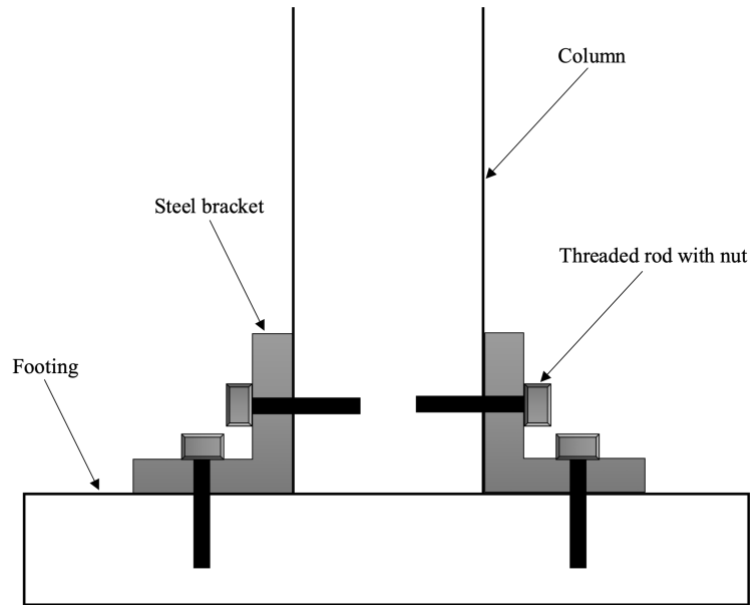

Figure 5.22 Proposed Column-Foundation Connection

In Table 5.15, the simplified connection design forces are calculated for the interior, edge, and corner columns. The forces are found by dividing the resultant moments, obtained from subsection 5.4.2, Table 5.12, by the critical column diameter of 850 mm.

Table 5.15 Column-Foundation Connection Design Forces

Column Location	Resultant Moment (kN·m)	Force (kN)
Interior	103.3	121.5
Edge	618.6	727.8
Corner	502.5	591.1

To facilitate the design and constructability of this connection, the most critical case of the edge column is used to form the basis of the connection design. For the maximum force of 727.8 kN and for a steel yield strength of 400 MPa, two 1.5-inch (38 mm) diameter rods of an area of 1000 mm² will need to be installed vertically on the side of the column following Equation 5.21. A schematic showing the configuration is illustrated in Figure 5.23 (a). The calculation for embedment can be noted below.

$$A = \frac{F}{\sigma}$$

Equation 5.21

σ : Normal stress

F : Force applied

A : Cross-sectional area of material with area parallel to the applied force vector

$$A = \frac{F}{\sigma} = \frac{727.8 \times 10^3 \text{ kN}}{400 \text{ MPa}} = 1819.5 \text{ mm}^2$$

∴ Need two → use two 1.5 – inch rods one single row vertically

Following Equation 5.22, three 1.5-inch rods of an area of 1000 mm² will need to be installed horizontally on each side of the column, therefore, the goal is to use four in 2x2 configuration. This is to accommodate the critical force of 727.8 kN and 0.6 of the 400 MPa steel yield strength. A schematic showing the configuration is illustrated in Figure 5.23 (b).

$$A = \frac{F}{\tau}$$

Equation 5.22

τ : Shear stress

$$A = \frac{F}{\tau} = \frac{727.8 \times 10^3 \text{ kN}}{0.6(400 \text{ MPa})} = 3032.5 \text{ mm}^2$$

∴ Need four → use four 1.5 – inch rods in 2x2 configuration horizontally

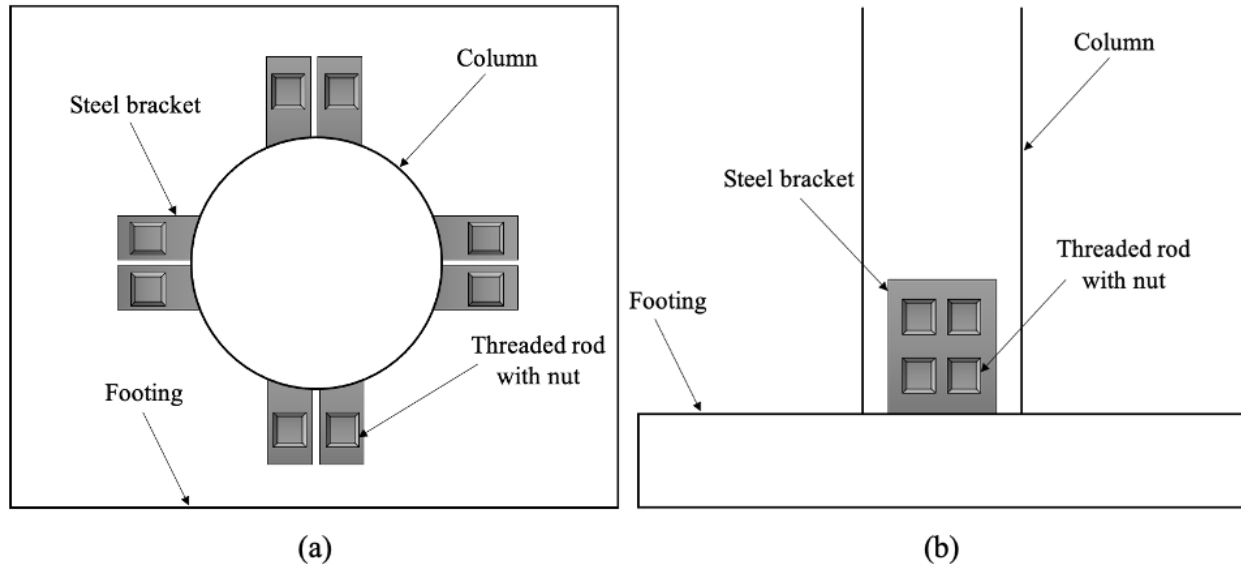

Figure 5.23 Column-Foundation Connection Design Configuration

These dowels will be embedded in the concrete using epoxy or grout to secure them in the column and foundation. As this is a round column, four L-brackets are to be installed in the north, south, east, and west direction. Note that designing the foundation itself is outside the scope of this thesis. To check the required development length for the proper connection between the two structural interfaces, the following equation according to 12.3.2 in A23.3-19 is used.

$$l_{db} = \frac{0.24d_b f_y}{\sqrt{f'_c}} \quad \text{but not less than} \quad 0.044d_b f_y \quad \text{Equation 5.23}$$

$$l_{db} = \frac{0.24(38 \text{ mm})(400 \text{ MPa})}{\sqrt{40 \text{ MPa}}} = 576.8 \text{ mm}$$

$$0.044d_b f_y = 0.044(38 \text{ mm})(400 \text{ MPa}) = 668.8 \text{ mm governs} \rightarrow \text{use } 675 \text{ mm}$$

5.4.4.2 Column-Slab Connection Design

For the column-slab connection, three design approaches were considered. Option 1 employs a post-installed concrete corbel or collar with a drop panel design to act as additional support. Option 2 involves cutting the pre-existing slab approximately 150 mm from the face of the column leaving

a natural corbel on the column where the slabs could then rest on top. Option 3 involves steel brackets that are to be drilled into the columns using threaded rods with a nut along with steel jacketing. The approach of encasing a reinforced concrete column in a steel jacket is often used as a cost-effective retrofit strategy for columns that are part of seismically deficient structures (Fouché et al., 2016). Figure 5.24 (a) and (b) demonstrates what options 1 and 2 will look like respectively and Figure 5.25 shows design connection option 3.

Like the previous subsection, the ideal options are those that will be easier to deconstruct. As such, option 1 was ruled out since it will require mechanical cutting to disassemble the design. Between options 2 and 3, option 3 was selected as it is more superior in its constructability since it will have demountable screws.

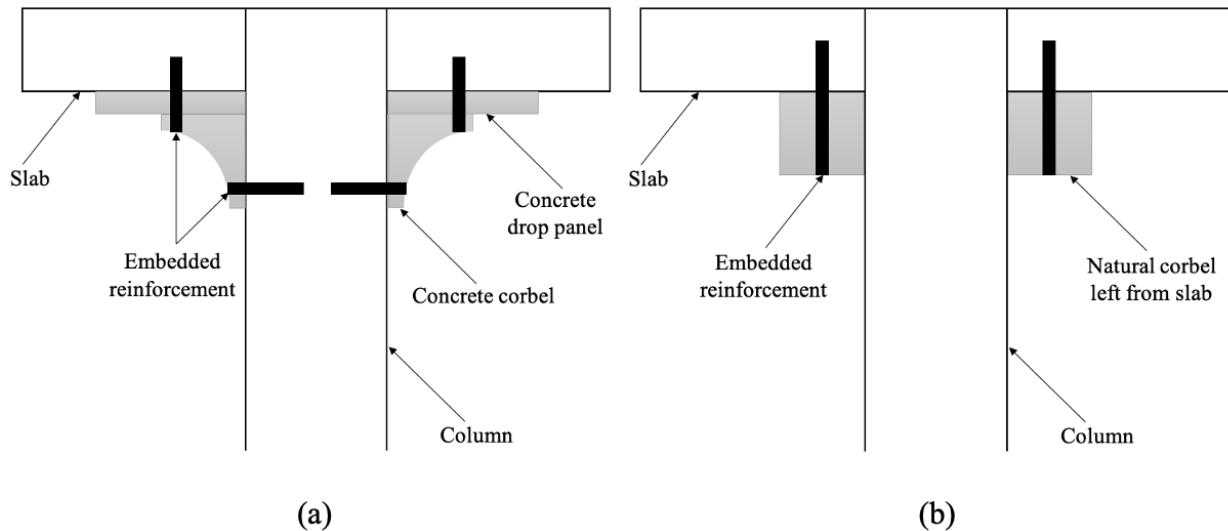

Figure 5.24 Column-Slab Connection Options

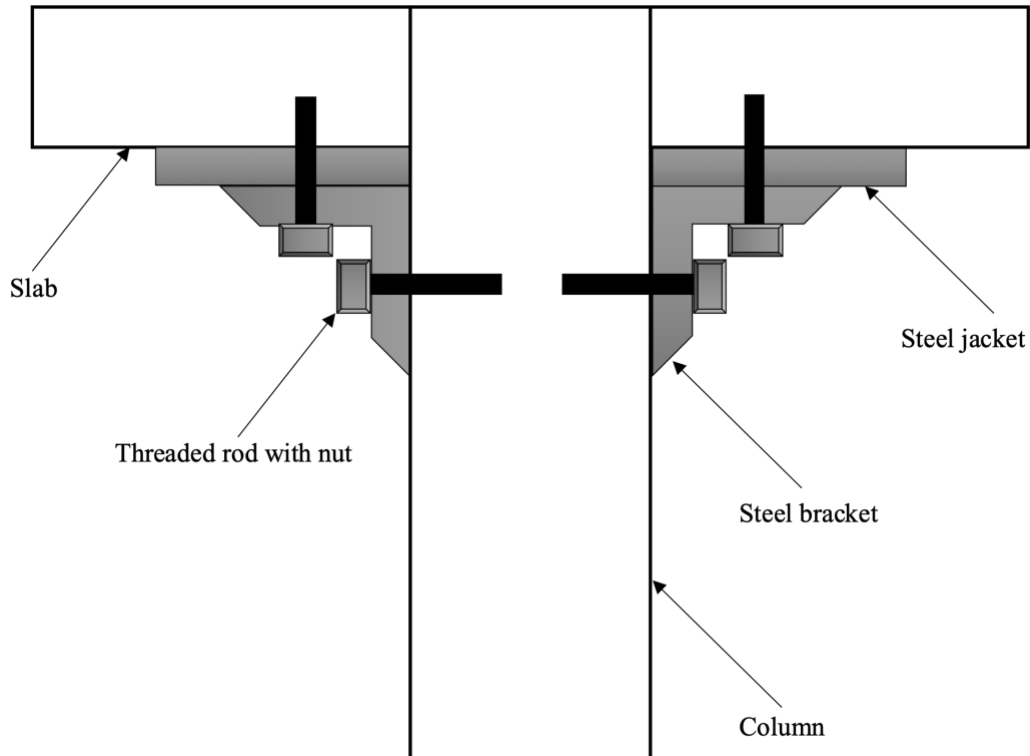

Figure 5.25 Proposed Column-Slab Connection

In Table 5.16, the design forces for the column-slab connection are outlined. They are extracted from Table 5.7, Table 5.8, and Table 5.9 for one storey then factored using the critical load combination of $1.25D + 1.4L$. Using Equation 5.22, the area of the reinforcement needed is calculated.

Table 5.16 Column-Slab Connection Design Forces

Column Location	Factored Load (kN)
Interior	835.2
Edge	417.6
Corner	208.2

$$A = \frac{F}{\tau} = \frac{(835.2 \times 10^3 \text{ kN})}{0.6(400 \text{ MPa})} = 3479.2 \text{ mm}^2$$

\therefore Need four \rightarrow use four 1.5

– inch rods distributed around the perimeter of the column

Similarly, to the previous connection design, these dowels will be epoxied to secure them in the column. As this is a round column, the four 1.5-inch will be distributed evenly around the perimeter of the column in the north, south, east, and west direction and be embedded 675 mm.

5.4.4.3 Slab-Slab Connection Design

For the slab-slab connection, two design approaches were considered. The first option, illustrated in Figure 5.26 (a), involved using a steel I-beam and fasteners. The ends of the slab sit in the nook of a W310-60 I-beam on either side, the slabs are then secured to the I-beam using fasteners to ensure that they don't slip out; a flooring material is then applied over the top. However, the clear distance between the top and bottom flanges is 277 mm, and with the slab being 250 mm, this means that there will be a 27 mm gap. While this gap can be grouted, it will require a substantial amount, and further, it will create a big bump in the floor. An alternative could be to get a customized beam made; however, this will increase the cost and labour which is not favourable. A second alternative, illustrated in Figure 5.26 (b), uses a rubber seal that is flexible and could be installed to connect the slab components. It is noted that there will very minor discontinuities in deflection between adjacent slabs in option 2; however, slab deflections are expected to be small due to the slabs being thicker than typically used for residential structures. Initially, this connection was not being relied on as a structural connection, so this approach was viewed as acceptable. However, due to the high positive moment demand noted in the first yield line calculation option, it was concluded that this approach could no longer be used. Therefore, a third alternative was developed and selected. This proposed connection, illustrated in Figure 5.27, uses grout to fill the gaps between the slabs and adds an FRP layer applied on the top surface to enable transfer of negative moments along the column lines (i.e., between adjacent slab edges). Considering the relatively low moment demand of 18.2 kN·m/m, a thin layer of CFRP material (1 mm thick with tensile strength of 1500 MPa) can easily achieve the required capacity, and should extend at least 300 mm on either side of the joint to avoid premature debonding failure. FRP sheets also have the distinct advantage of having a negligible weight and thickness, and are easily installed on site.

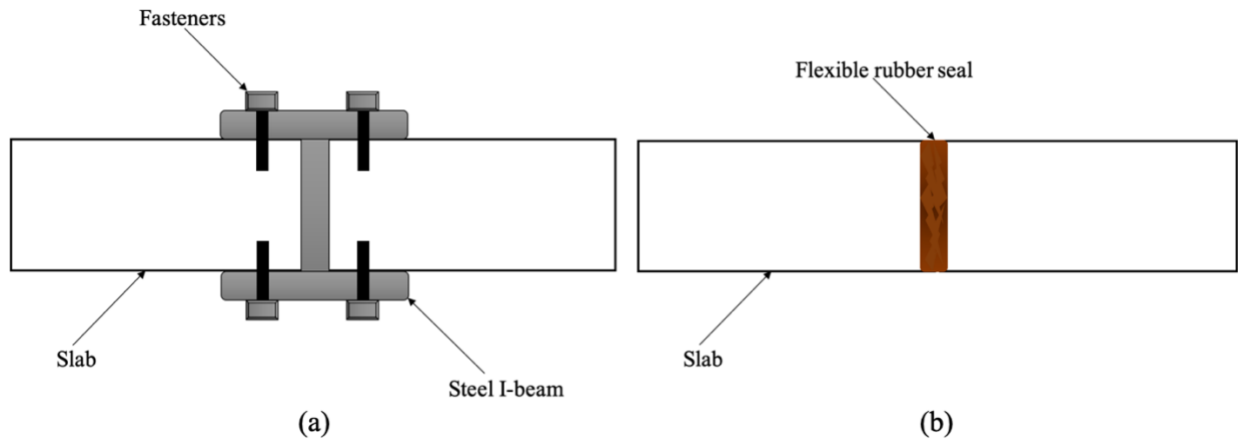

Figure 5.26 Slab-Slab Connection Options

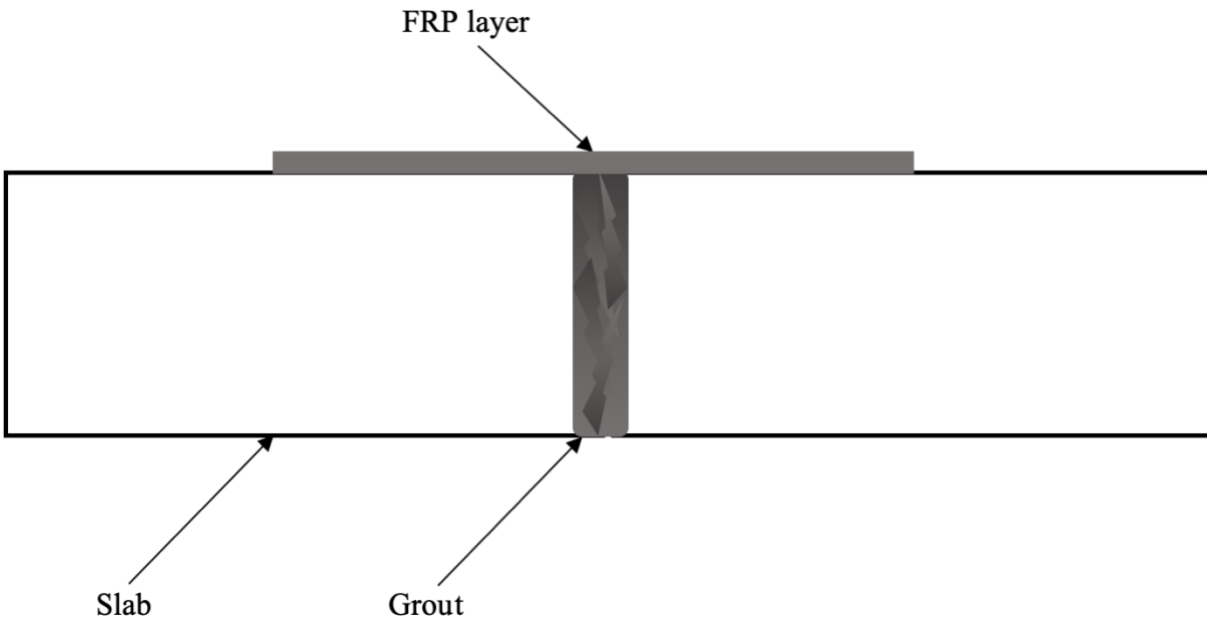

Figure 5.27 Proposed Slab-Slab Connection

5.5 Discussion

In this chapter, the FSS Building at the UO campus was used as the subject of study. The 15-storey reinforced concrete structure's gravity load resisting members were disassembled and then inventoried. As is the case with the bridge case study, the mechanical cutting schemes proposed are hypothetical and will require experimental testing to evaluate their feasibility. Due to this building's irregular geometry, it was more challenging to retain uniform structural elements –

mainly slabs – as the cut shapes would be very uneven. The columns present in the building regularly changed shapes as a circular column in one floor can transition to a rectangular or square column on another floor. Therefore, the maximum length where the columns were mechanically cut was limited at two-floor lengths. When the hypothetical proposed building plan was developed using reused building elements, a couple of different column designs had to be used to accommodate the repurposed building thus constraining the redesign. The connection design for the building had to consider three categories of connections: the column-foundation, the column-slab, and the slab-slab. It is important to highlight that no beams were integrated in this design following the original design of the FSS Building being a mostly flat slab structure. As such, no beam-slab or beam-column connection designs were considered; however, this is an area worth researching in the future. Moreover, the connection designs should undergo comprehensive experimental testing. However, it is important to note that connecting reused concrete components is somewhat similar to connecting precast concrete components. As such, this could provide helpful conceptual guidelines for connection details for common cases.

One of the difficulties noted in these case studies is having to reverse engineer the design process – something most designers do not regularly do and are not particularly trained in. Often, designs begin with a clean slate, whereas the process is inverted when reuse is implemented. This also raises the challenge of having to interpret other professionals' designs and construction drawings. Sometimes, the drawings are not fully clear or are not completely available as they can be retained from older structures. Moreover, some assumptions have to be made since sometimes the drawings do not provide every detail needed for redesign as they were not intended for that purpose. As such, it is recommended that structures being built today have a comprehensive record of the construction drawings so that it can facilitate future deconstruction and reconstruction of structures.

The objective of this case study has been realised; however, it has also raised several points for future areas of research. The focus of the case study has been on the gravity load resisting members; as such, studies incorporating a lateral load resisting system will need to be done to complement the research done here. The same should also be done for the foundation to explore potential reuse opportunities. Lastly, as concluded in the bridge case study, structures designed today should be developed with disassembly and adaptability design concepts applied. This will

Chapter 5: University of Ottawa Building Case Study

significantly ease the process of material reuse – in this case, concrete – and allow for maximum recovery.

6 Chapter 6: Conclusions and Recommendations for Future Work

6.1 Summary

A total of 125 professionals, grouped into four streams, participated in the Reuse in the Concrete Industry survey. Their quantitative and qualitative responses were analyzed to determine the degree of concrete reuse being done by the C&D industry in the Canadian context. Furthermore, their opinions on the practice of reusing concrete were collected to understand the industry's position on the practice and elicit the obstacles and benefits they perceive with the concept. Based on some of the technical challenges noted in the responses, two case studies were developed to address the engineering difficulties faced when reusing concrete for structural applications. One case was for a campus building located at the University of Ottawa while the other was for a local bridge in the City of Ottawa. The case studies began with a disassembly plan, where these existing structures were hypothetically deconstructed, followed by an inventory of the retained structural components. Then, new conceptual plans of the repurposed structures were created where those previously retained structural elements were repurposed. Load and capacity calculations followed to assess the design loads of the new designs and compare them to the capacity of the reused structural components for safety. Lastly, a reassembly plan with a focus on connection design concluded each case study.

6.2 Conclusions

The conduct of this research led to several key findings; a summary of the conclusions that can be drawn out from the survey and case studies is given below:

- The attentiveness of the stakeholders to the challenge of reuse is a significant component in the effective implementation of reuse in construction projects. A development project must begin with the completion of a pre-demolition inventory. This inventory, when combined with a reuse strategy, allows the project to be centered around reuse (Maerckx et al., 2019).

- The reuse approach should be tailored to the structure in question. When working with a building, it is evident that its structural members are located internally where they are not exposed to environments that promote deterioration in their current life and in their reused life. However, for a bridge, all its elements are external and as such, they are exposed to likely harsh environments that can potentially stimulate corrosion and faster degradation. Although a detailed condition assessment of existing members was outside the scope of this research, a reduction factor on bridge elements was imposed to account for this variance. The development of a rating system could facilitate a reliability-based approach to design with reused components.
- ‘Regular’ structures with simple geometries proved to be more optimal for reuse, whereas irregular structures were more challenging to work with. In the case study of the FSS Building, a visibly irregular structure, it had minimal use of beams that were almost always varying in size and design thus, they were not lending themselves to be very practical for reuse. The same can be noted for the slabs, where due to the awkward shape of the building only a fraction of the slab was retained.
- In the redesign process, where the structural components from the inventory of the existing design are repurposed, the new design is generally constrained by the geometry of available components. This was the case with the bridge, where I-girders with a slab design were implemented, and with the building, where the mostly flat-slab approach was used. This approach requires design flexibility and intuitive databases of local inventories, thus placing significantly more emphasis on the pre-design phase of a project.
- When reusing elements from existing structures, some limitations are observed on architectural creativity. In the instance of the building case study, there are a certain number of circular, square, and rectangular columns available that govern any future design. However, in a way, the reuse approach also promotes creativity as designers – engineers and architects alike – are expected to optimize their designs to make the maximum use of the available resources while effectively meeting new design needs.
- An ideal reuse construction project starts at the initial design stage so that the eventual disassembly and repurposing of the structure is considered from the structure’s inception (i.e., cradle to cradle design). Therefore, infrastructure projects being designed today should involve considerations of the disassembly and adaptability concepts outlined in

2.7.2.2. to not only facilitate the reuse process but to also maximize the amount of reuse done. This early intervention will also be more cost effective in the long term.

- When working with older structures, it can be difficult to obtain all the drawings because they might not be available in full. While this is less of an issue in today's highly digitized world, this does present some challenges when attempting to implement the concept on older structures.
- Older structures are built based on older design codes and sometimes that could mean the redesign would be insufficient in certain areas by today's accepted code. Designers should be aware of this and remediate by retrofitting their designs to meet current code requirements if necessary.
- To make reuse in the construction industry more accessible, having a systematic approach to the process would not only facilitate it but provide more confidence in it. As such, there is a need for standardized structural evaluations for quality control and assurance – this is especially important when working with older decommissioned structures. Moreover, the development of protocols and compliance checks will be necessary to ensure safety.
- Following the previous point, having systematic characterization of structures – specifically buildings – by grouping them with respect to geometry, code, etc. and evaluating their reuse potential would be very helpful for asset managers when prioritizing several potential reuse projects.
- Designers should have a clear understanding of the time constraints and budget allowance to make the appropriate decisions for their projects. Careful disassembly can be a time-consuming and expensive process compared to conventional demolition, and new connections may require customized design solutions. The use of standardized or modular structural components can facilitate this process.
- For a fully circular economy where each component could potentially have multiple service lives, new demountable connection types should be developed; nevertheless, such designs require extensive testing and are thus considered outside the scope of this thesis.
- There is a significant opportunity in Canada to do more in the areas of reclaiming concrete to be reused as recovered concrete generally ends up in landfills, and at best, downcycled to base aggregates. The work presented in this thesis suggests that while there are significant challenges ahead, the technical challenges associated with the reuse of structural

concrete members can be overcome with sufficient buy-in from all stakeholders as well as supportive policies and incentives.

6.3 Recommendations for Further Research and Future Action

The main goal of this research was to explore the feasibility of reuse in the concrete industry. In pursuit of this goal, a survey was created and dispatched to key concrete industry groups, and two theoretical case studies were developed based on existing infrastructure in the city. This goal has been achieved, as demonstrated in the in the previous chapters. However, the conclusion of this research has also led to the following recommendations of future research in the field of concrete reuse that should be addressed to further propel the concept forward:

- **Deeper exploration of industry groups' perceptions**

While the survey results were more individualistic, there is a need for focus groups and interviews with industry leaders and large companies to obtain deeper insights of the current concrete practices in the C&D industry.

- **Integration of experimental case studies**

Several survey respondents noted the need for significant research findings, previous successful projects, and testing reports that would support the concept of reuse and establish it in the industry. Having real-life scenarios of concrete reuse where important metrics are collected prior, during, and after the project would present an example that can be followed.

- **Additional research to study various technical, logistical, and liability concerns**

Since issues related to cost, logistics, life cycle assessment, and liability concerns are not addressed in this research as they fall outside its scope, there is a need to address them in a comprehensive and holistic manner in future research. The development and testing of demountable connections for structural elements will be a focal research point. Introducing reliability studies to calibrate the risk of reused structural components would be helpful as developing clear protocols and specifications for classification and quality assurance of reused components. This would increase

the confidence in the structural integrity of these members. Moreover, a supply chain for reused concrete needs to exist before reuse can be considered at a large scale.

- **Increase of awareness of concrete's adverse impacts while growing the resources and trainings on how to apply the concept of reuse efficiently**

While all survey participants across all four streams unanimously agreed that there are important benefits to incorporating reused concrete components in construction, most are not fully aware of the negative environmental impacts associated with concrete production and demolition. This is especially true of clients, who often lack the understanding of what the industry entails. As such, ensuring that professionals and the public is knowledgeable about the environmental footprint of concrete production is important so that they remain conscious of their development practices. Furthermore, providing tools and resources for designers, skilled labourers, and other professionals involved in the concrete industry about proper reuse practices will be critical in making reuse a mainstream practice in the C&D industry.

- **Development of guidelines, codes, and standards to support reuse practice**

Articles or subsections in the NBCC (and CHBDC), as well as corresponding provincial building codes, should be added to introduce the idea, make recommendations, and pave the way for future use of the reclaimed building components. One of the survey comments emphasized that while reusable concrete might be a very good option, this will not be the case before it becomes a clear science.

- **Introduction of incentives to promote reuse practices**

There needs to be incentives to promote the practice of reusing concrete in the C&D industry. This could be financial in the form of discounts and/or governmental support. Another would be through providing LEED credits and/or credits through other sustainability metrics.

- **Creation of governmental policies, bills, and/or laws to mandate reuse practices**

As more research is done on concrete reuse and more resources become available, governments should consider implementing policies, bill, and/or laws to push the practice of reuse in the C&D

Chapter 6: Conclusions and Recommendations for Future Work

industry. An example of this would be capping the percentage of waste disposed in landfills by C&D companies and introducing fines to further enforce such rules.

Bibliography

- Addis, B. (2012). *Building with reclaimed components and materials: a design handbook for reuse and recycling*. Routledge.
- Agrawal, A. K., Jalinoos, F., Davis, N., Hoomaan, E., & Sanayei, M. (2018). *Foundation reuse for highway bridges*. United States: Federal Highway Administration.
- Ajdukiewicz, A., Brol, J., Dawczyński, S., & Adamczyk, K. (2013). Reuse of RC and PC precast members as contribution to sustainable construction. *Proceedings of fib Symposium*, (pp. 483-486). Tel-Aviv.
- Antonini, E., Giurdanella, V., & Zanelli, A. (2010). *Reversible Design: Strategies to Allow Building Deconstruction and a Second Life for Salvaged Materials*. Coventry University and The University of Wisconsin Milwaukee Centre for By-products Utilization.
- Bektas, B. A., & Albughdadi, A. J. (2019). *Drivers of Bridge Decommissioning in the United States*. Transportation Research Record.
- BioRegional Development Group. (2007). *Reclamation Led Approach to Demolition*.
- BluePlan Engineering. (2019). *Canadian Infrastructure Report Card 2019*. Canadian Infrastructure.
- Brambilla, G., Lavagna, M., Vasdravellis, G., & Andrea Castiglioni, C. (2019). Environmental benefits arising from demountable steel-concrete composite T floor systems in buildings. *Resources, Conservation & Recycling*, 133-142.
- Canadian Architect. (2014, December 17). *University of Ottawa Social Sciences Building wins multiple awards*. Retrieved from Canadian Architect:
<https://www.canadianarchitect.com/university-of-ottawa-social-sciences-building-wins-multiple-awards/1003395783-1003395785/>

Bibliography

- Canadian Standards Association Group. (2006). *Z782-06*. Mississauga: Canadian Standards Association.
- Chatham House Report. (2018, June 18). *Making Concrete Change: Innovation in Low-carbon Cement and Concrete Making Concrete Change: Innovation in Low-carbon Cement and Concrete*.
- City of Ottawa. (2018, April 5). *Design Guidelines For Corridor Components*. Retrieved from City of Ottawa: <https://ottawa.ca/en/city-hall/planning-and-development/community-plans-and-design-guidelines/design-and-planning-0-1-8>
- Cooper, T. (1994). *Beyond Recycling: The longer Life Option*. London: The New Economics Foundation.
- Crowther, P. (1999). Design for disassembly: An architectural strategy. *Queensland University of Technology Winter Colloquium*, (pp. 22-33).
- Deilmann, C., Effenberger, K.-H., & Banse, J. (2009). Housing stock shrinkage: vacancy and demolition trends in Germany. *Building Research & Information*, 660-668.
- Eckelman, M. J., Brown, C., Troup, L. N., Wang, L., Webster, M. D., & Hajjar, J. F. (2018). Life cycle energy and environmental benefits of novel design-for- T deconstruction structural systems in steel buildings. *Building and Environment*, 421-430.
- Fouché, P., Bruneau, M., & Chiarito, V. P. (2016). Modified steel-jacketed columns for combined blast and seismic retrofit of existing bridge columns. *ournal of Bridge Engineering*, 21(7).
- Gar, P., Mander, J., Head, M., & Hurlbauss, S. (2014). FRP slab capacity using yield line theory. *Journal of Composites for Construction*.
- Gartner, E. (2004). Industrially interesting approaches to “low-CO₂” cements. *Cement and Concrete Research*, 34(9), 1489-1498.

Bibliography

- Giroux Environmental Consulting. (2014). *State of Waste Management in Canada*. Kanata: Canadian Council of Ministers of Environment.
- Gorgolewski, M. (2006). The implications of reuse and recycling for the design of steel buildings. *Canadian Journal of Civil Engineering*, 33, 489-496.
- Gorgolewski, M., Straka, V., Edmonds, J., & Sergio, C. (2006). *Facilitating Greater Reuse and Recycling of Structural Steel in the Construction and Demolition Process*. Toronto: Ryerson University, Canadian Institute of Steel Construction.
- Government of the Netherlands. (2020, May). *From a Linear to a Circular Economy*. Retrieved from Government of Netherlands: <https://www.government.nl/topics/circular-economy/from-a-linear-to-a-circular-economy>
- Howden. (2020, January 10). *Concrete vs Cement: What's The Difference?* Retrieved September 2021, from Howden: <https://www.howden.com/en-us/articles/cement/how-is-cement-made>
- Hradil, P., Talja, A., Wahlström, M., Huuhka, S., Lahdensivu, J., & Pikkuvirta, J. (2014). *Re-use of Structural Elements: Environmentally Efficient Recover of Building Components*. Tampere.
- Huntzinger, D., & Eatmon, T. (2009). A life-cycle assessment of Portland cement manufacturing: comparing the traditional process with alternative technologies. *Journal of Cleaner Production*, 668-675.
- Huuhka, S., Kaasalainen, T., Hakanen, J., & Lahdensivu, J. (2015). Reusing concrete panels from buildings for building: Potential in Finnish 1970s mass housing. *Resources, Conservation and Recycling*, 105-121.
- Kay, T., & Essex, J. (2009). *Pushing Re-use: towards a low-carbon construction industry*. Retrieved from <http://www.bioregional.com/files/publications/pushingreuse.pdf>
- Mäkiö, E., Malinen, M., Neuvonen, P., Vikström, K., Mäenpää, A., Saarenpää, J., & Tähti, E. (1994). In *Blocks of Flats 1960–1975*. Helsinki.

Bibliography

- Maerckx, A.-L., d'Otreppe, Y., & Scherrier, N. (2019). Building circular in Brussels: an overview through 14 inspiring projects. *IOP Conference Series: Earth and Environmental Science*. Vol. 225, No. 1, p. 012059. IOP Publishing.
- Marzouk, M., & Azab, S. (2014). Environmental and economic impact assessment of construction and demolition waste disposal using system dynamics. *Resources, Conservation and Recycling*, 41-49.
- Master Builders Solutions. (2019, December 20). *7 Innovative Solutions to Reduce Concrete's Carbon Footprint*. Retrieved from Master Builders Solutions: <https://www.watertightconcrete.master-builders-solutions.com/latest-news/7-innovative-solutions-to-reduce-concretes-carbon-footprint>
- Mehta, P. K. (2002). Greening of the concrete industry for sustainable development. *Concrete international*, 24(7), 23-28.
- Miller, S., Horvath, A., & Monteiro, P. (2018). Impacts of booming concrete production on water resources worldwide. *Nature Sustainability*, 69-76.
- Nordby, A. S. (2019). Barriers and opportunities to reuse of building materials in the Norwegian construction sector. *IOP Conference Series: Earth and Environmental Science*. Vol. 225, No. 1, p. 012061. IOP Publishing.
- O'Connor, J. (2004). Survey on actual service lives for North American buildings. *Woodframe Housing Durability and Disaster Issues*. Las Vegas.
- Ontario Provincial Standard Specifications. (2016). *Ministry of Transportation Technical Publications*. Retrieved from Government of Ontario: [http://www.raqsb.mto.gov.on.ca/techpubs/ops.nsf/0/3674be1315e7013e85258082006291b8/\\$FILE/OPSS.MUNI%20180%20Nov16.pdf](http://www.raqsb.mto.gov.on.ca/techpubs/ops.nsf/0/3674be1315e7013e85258082006291b8/$FILE/OPSS.MUNI%20180%20Nov16.pdf)
- Ontario Provincial Standard Specifications. (2018). *Ministry of Transportation Technical Publications*. Retrieved from Government of Ontario:

Bibliography

- [http://www.raqsb.mto.gov.on.ca/techpubs/ops.nsf/0/5ad2267df782ea2d85258082006290fa/\\$FILE/OPSS.MUNI%20510%20Nov18.pdf](http://www.raqsb.mto.gov.on.ca/techpubs/ops.nsf/0/5ad2267df782ea2d85258082006290fa/$FILE/OPSS.MUNI%20510%20Nov18.pdf)
- Ontario Provincial Standard Specifications. (2019). *Ministry of Transportation Technical Publications*. Retrieved from Government of Ontario:
[http://www.raqsb.mto.gov.on.ca/techpubs/ops.nsf/0/eefb9f2df9e490178525808200629092/\\$FILE/OPSS.MUNI%20928%20Apr19.pdf](http://www.raqsb.mto.gov.on.ca/techpubs/ops.nsf/0/eefb9f2df9e490178525808200629092/$FILE/OPSS.MUNI%20928%20Apr19.pdf)
- Polytechnique Montréal. (2019). *Engineers Canada – Sustainability in Practice*. EDUlib.
- Salama, W. (2017). Design of concrete buildings for disassembly: An explorative review. *International Journal of Sustainable Built Environment*.
- Tam, V. W. (2008). Economic comparison of concrete recycling: A case study approach. *Resources, conservation and recycling*, 52(5), 821-828.
- University of Ottawa. (2021, 09 14). *Social Sciences Building*. Retrieved from uOttawa.ca:
<https://socialsciences.uottawa.ca/about-faculty/fss-building>
- van Bueren, B., Leenders, M., & Nordling, T. (2019). Case Study: Taiwan's pathway into a circular future for buildings. *IOP Conference Series: Earth and Environmental Science*. 225. IOP Publishing.
- Yang, H. K. (2020, November 23). Alternative materials could shrink concrete's giant carbon footprint. *Chemical & Engineering News*, 98(45).
- Yeheyis, M., Hewage, K., Alam, M., Eskiicioglu, C., & Sadiq, R. (2013). An overview of construction and demolition waste management in Canada: a lifecycle analysis approach to sustainability. *Clean Technologies and Environmental Policy*, 81-91. Retrieved from <https://doi.org/10.1007/s10098-012-0481-6>

Appendix A: Survey Content

Introduction

Welcome Remarks

Reuse in the Concrete Industry

Thank you for taking a few minutes to answer some questions! If you complete the survey, you will be entered to a \$50 Amazon eGift Card draw!*

We value your time as an industry professional and have developed the survey to be completed in 5-8 minutes or less. We thank you in advance for completing the survey in full. This survey will help guide the work of this research and your input is invaluable to us.

Who are we?

Based at the University of Ottawa's Department of Civil Engineering, we are researchers who are looking into the feasibility of reuse of concrete in the Ontario industry. To find out more about our department, please click [HERE](#).

Why you?

We believe your work has an impact in the Ontario concrete industry. By sharing your experiences in your profession, you will influence the path of this research and render it more useful to the industry itself in the future.

What would we like to know?

We are hoping to find out about the perception of concrete reuse as well as the action of concrete reclamation performed by your company or agency. If you are not the right person to answer the questions below, please forward this survey to someone else at your work community.

This master's research project is being carried by Zaineb Al-Faesly (MAsc candidate) and is supervised by Dr. Martin Noël (supervisor). If you have any questions, please connect with us. Please note that not participating in this survey will not have a negative impact on the relationship between you and the person who shared the recruitment text with you.

Please click at the following link to find the survey: <https://www.surveymonkey.ca/r/Reuse-in-the-Concrete-Industry>

Thank you for your support!

*The winner will be selected at random. Please note that in order to enter the draw you must provide your contact information as directed in the last optional section of the survey so we can contact you if you win.

Implied Consent Form

Title of the Study: Feasibility of Reuse in the Concrete Industry

Supervisor: Dr. Martin Noël
Associate Professor
Department of Civil Engineering
University of Ottawa
Ottawa, ON
(613) 562-5800 ext. 2307

Principal Investigator: Zaineb Al-Faesly

You are invited to participate in the abovementioned master's thesis project conducted by Zaineb Al-Faesly, MASc candidate, who is being supervised by Dr. Martin Noël.

If you wish to participate in this study, please complete the linked survey. Your decision to complete and return this survey will be interpreted as an indication of your consent to participate. The survey should take you approximately 5-8 minutes to complete. If you don't know the answer to any of the questions, you can simply select "I don't know". Once you have completed the survey, please click done.

From this research, we wish to learn about the perception of concrete reuse as well as the action of concrete reclamation performed by your company or agency.

The information that you will share will remain strictly confidential and will be used solely for the purposes of this research. The only people who will have access to the research data are the Principal Investigator and Supervisor. Your answers to open-ended questions may be used verbatim in presentations and publications but neither you nor your organization will be identified. In order to minimize the risk of security breaches and to help ensure your confidentiality, we recommend that you use standard safety measures such as signing out of your account, closing your browser, and locking your screen or device when you are no longer using them/when you have completed the study.

The survey data will be kept in a secure password protected account on the computers of the investigators. The data collected will be stored indefinitely on the survey platform account.

Faculté de génie
Faculty of Engineering
☎ 613-562-5682
📠 613-562-5174
🖱 genie.uOttawa.ca
🖱 engineering.uOttawa.ca
📍 161 Louis Pasteur
Ottawa ON K1N 6N5
Canada



Appendix A: Survey Content

You are under no obligation to participate and if you choose to participate, you may bypass questions that you cannot answer by selecting “I don’t know” if you don’t know the response. Completing and returning of the questionnaire by you implies consent. If, however, at any point upon the completion of the survey you wish to withdraw your responses, please connect with the Principal Investigator to arrange the withdrawal of your data.

To thank you for your contribution to the research project, you will be given the option to enter your name in a draw to win an Amazon eGift Card valued at \$50. The draw is open to all research participants who enter their name in the draw, regardless of whether they decide to not continue further participating in the research project.

Upon completion of the study in the fall, a name will be randomly selected amongst those who have entered and the person whose name is drawn will be informed by email and/or phone. If the person cannot be reached within 14 days from the date of the draw, the prize will be awarded to the second name that is randomly selected and so on until the prize has been awarded. The odds of winning a prize will depend on the number of eligible entries received.

Your contact information that you provide when you enter the draw is collected for the purposes of contacting you if your name is selected in the draw and if you give permission to contact you for additional information for this research study. Your name and the contact information you have provided will be kept confidential and then destroyed once the prizes have been awarded and the research has been completed.

We reserve the right to cancel the draw or cancel the awarding of the prize if the integrity of the draw or the research or the confidentiality of participants is compromised. The draw is governed by the applicable laws of Canada.

If you have any questions or require more information about the study itself, you may contact the researcher or her supervisor at the numbers or emails mentioned herein.

If you have any questions with regards to the ethical conduct of this study, you may contact the Protocol Officer for Ethics in Research, University of Ottawa, Tabaret Hall, 550 Cumberland Street, Room 154, Ottawa, ON K1N 6N5, tel.: (613) 562-5387 or ethics@uOttawa.ca.

Please keep this form for your records.

Thank you for your time and consideration.

Sincerely,

Zaineb Al-Faesly, MASC Candidate
Principal Investigator

Faculté de génie
Faculty of Engineering
☎ 613-562-5682
☎ 613-562-5174
📧 genie.uOttawa.ca
📧 engineering.uOttawa.ca
📍 161 Louis Pasteur
Ottawa ON K1N 6N5
Canada



Certificate of Ethics Approval

27/10/2019

Université d'Ottawa

Bureau d'éthique et d'intégrité de la recherche

University of Ottawa

Office of Research Ethics and Integrity

CERTIFICAT D'APPROBATION ÉTHIQUE | CERTIFICATE OF ETHICS APPROVAL

Numéro du dossier / Ethics File Number	H-08-19-4861
Titre du projet / Project Title	Feasibility of Reuse in the Concrete Industry
Type de projet / Project Type	Thèse de maîtrise / Master's thesis
Statut du projet / Project Status	Approuvé / Approved
Date d'approbation (jj/mm/aaaa) / Approval Date (dd/mm/yyyy)	27/10/2019
Date d'expiration (jj/mm/aaaa) / Expiry Date (dd/mm/yyyy)	26/10/2020

Équipe de recherche / Research Team

Chercheur / Researcher	Affiliation	Role
Zaineb AL-FAESLY	Département de génie civil / Department of Civil Engineering	Chercheur Principal / Principal Investigator
Martin NOËL	Département de génie civil / Department of Civil Engineering	Superviseur / Supervisor

Conditions spéciales ou commentaires / Special conditions or comments

550, rue Cumberland, pièce 154 Ottawa (Ontario) K1N 6N5 Canada 550 Cumberland Street, Room 154 Ottawa, Ontario K1N 6N5 Canada

613-562-5387 • 613-562-5338 • ethique@uOttawa.ca / ethics@uOttawa.ca
www.recherche.uottawa.ca/deontologie | www.recherche.uottawa.ca/ethics

Université d'Ottawa

Bureau d'éthique et d'intégrité de la recherche

Le Comité d'éthique de la recherche (CÉR) de l'Université d'Ottawa, opérant conformément à l'*Énoncé de politique des Trois conseils* (2014) et toutes autres lois et tous règlements applicables, a examiné et approuvé la demande d'éthique du projet de recherche ci-nommé.

L'approbation est valide pour la durée indiquée plus haut et est sujette aux conditions énumérées dans la section intitulée "Conditions Spéciales ou Commentaires". Le formulaire « Renouvellement ou Fermeture de Projet » doit être complété quatre semaines avant la date d'échéance indiquée ci-haut afin de demander un renouvellement de cette approbation éthique ou afin de fermer le dossier.

Toutes modifications apportées au projet doivent être approuvées par le CÉR avant leur mise en place, sauf si le participant doit être retiré en raison d'un danger immédiat ou s'il s'agit d'un changement ayant trait à des éléments administratifs ou logistiques du projet. Les chercheurs doivent aviser le CÉR dans les plus brefs délais de tout changement pouvant augmenter le niveau de risque aux participants ou pouvant affecter considérablement le déroulement du projet, rapporter tout événement imprévu ou indésirable et soumettre toute nouvelle information pouvant nuire à la conduite du projet ou à la sécurité des participants.

University of Ottawa

Office of Research Ethics and Integrity

The University of Ottawa Research Ethics Board, which operates in accordance with the *Tri-Council Policy Statement* (2014) and other applicable laws and regulations, has examined and approved the ethics application for the above-named research project.

Ethics approval is valid for the period indicated above and is subject to the conditions listed in the section entitled "Special Conditions or Comments". The "Renewal/Project Closure" form must be completed four weeks before the above-referenced expiry date to request a renewal of this ethics approval or closure of the file.

Any changes made to the project must be approved by the REB before being implemented, except when necessary to remove participants from immediate endangerment or when the modification(s) only pertain to administrative or logistical components of the project. Investigators must also promptly alert the REB of any changes that increase the risk to participant(s), any changes that considerably affect the conduct of the project, all unanticipated and harmful events that occur, and new information that may negatively affect the conduct of the project or the safety of the participant(s).

Germain ZONGO

Responsable d'éthique en recherche / Protocol Officer

Pour/For **Daniel LAGAREC** Président(e) du/ Chair of the **Comité d'éthique de la recherche en sciences de la santé et sciences / Health Sciences and Sciences Research Ethics Board**

550, rue Cumberland, pièce 154 Ottawa (Ontario) K1N 6N5 Canada

550 Cumberland Street, Room 154
Ottawa, Ontario K1N 6N5 Canada

613-562-5387 • 613-562-5338 • ethique@uOttawa.ca / ethics@uOttawa.ca
www.recherche.uottawa.ca/deontologie | www.recherche.uottawa.ca/ethics

Terminology

To help you answer the questions accurately, we have identified and defined some key terms: **Reclaimed** materials are those that have been diverted from the waste stream and not disposed in landfills, rather, they are reused or recycled:

1. **Reused** materials are considered to be any materials taken from the waste stream and **reused in their original form, with minimal reprocessing**. They may be cut to size, adapted, cleaned up, or refinished, but they are fundamentally retaining their original form.

- *An example of reuse: A retaining wall built with concrete blocks is carefully disassembled and the old components are cleaned and stacked on pallets ready for reuse as reclaimed material to create a new concrete wall.*

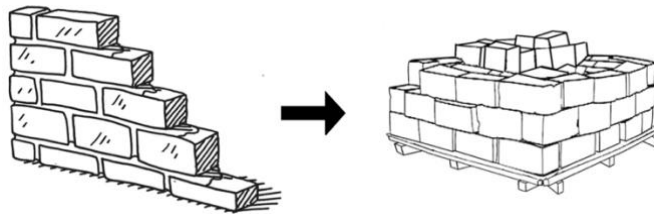

2. **Recycled** materials are considered to be any materials taken from the waste stream and **reprocessed and remanufactured** (i.e., downcycled) to form part of a new product (e.g., aggregates).

- *An example of recycling: An old concrete block wall is knocked down to ground level using a machine, with the broken concrete pieces then being crushed and screened in a mechanical crusher to create an aggregate substitute.*

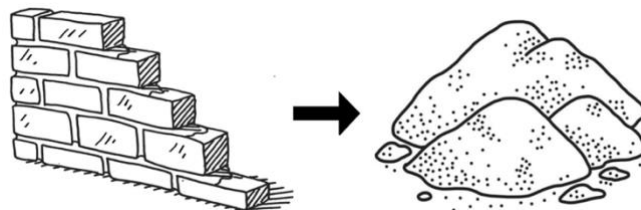

Please note that questions marked by an asterisk (*) are mandatory questions.

Questions

Stream Identifier

***Question:** Which of the following titles do you identify most with?

[Multiple Choice:

-Concrete Professional (e.g., design engineer, consultant, and/or quality control)

-Concrete Structure Owner (e.g., municipality, provincial or federal agency, and/or private owner)

-Concrete Supplier (e.g., precast, ready-mix)

-Concrete Contractor (e.g., builders, demolishers)]

Questions for the Concrete Professional Stream

***Question:** Has your company had any experience incorporating reclaimed concrete on a previous project?

[Multiple choice: Yes/No]

If “Yes”:

Question: Approximately what percentage of your projects in the last year have incorporated reclaimed concrete?

[Slider: 0-100%]

***Question:** Approximately what percentage of the reclaimed concrete was:

- Re-used (i.e., in its original form)
- Down-cycled (i.e., crushed and used as aggregate or base material)

[Dropdown menu: 0%, 0-20%, 20-40%, 40-60%, 60-80%, 80-100%, or I don't know]

***Question:** For what purpose(s) or application(s) did you use reclaimed concrete? Check all that apply:

[Checkboxes:

-Base material

-Aggregate in concrete

-Non-structural applications (e.g., drainage)

-Residential construction (e.g., apartment building)

-Commercial construction (e.g., office space or warehouse)

-Public infrastructure

Appendix A: Survey Content

-I don't know

-Other (please specify)

***Question:** Was the original source of the reclaimed concrete known?

[Multiple choice: Yes/No/I don't know]

Question: If answered "yes" to the previous question, please specify:

[Single text box]

***Question:** Would you consider using reused concrete (i.e., in its original form, not down-cycled) in future projects?

[Multiple choice: Yes/No/Maybe]

Question: Why, why not, or why maybe?

[Comment box]

***Question:** Are you aware of any technical documents (i.e., standards, codes, guidelines etc.) related to the re-use of concrete?

[Multiple choice: Yes/No/I don't know]

Question: If yes, please share the document title(s) below:

[Comment box]

If "No":

***Question:** Would you consider using reclaimed concrete (either re-used or recycled) on a future project?

[Multiple choice: Yes/No/Maybe]

Question: Why, why not, or why maybe?

Appendix A: Survey Content

[Comment box]

***Question:** Would you consider using re-used concrete in its **original form** (not down-cycled as crushed aggregate or base material) for future projects?

[Multiple choice: Yes/No/Maybe]

Question: Why, why not, or why maybe?

[Comment box]

Questions continued for both “Yes” or “No” responses:

***Question:** Do you consider re-use of structural concrete components in an acceptable condition for new construction projects to be feasible?

[Multiple choice: Yes/No/I don't know]

Question: Why or why not?

[Comment box]

***Question:** Which of the following, if any, would lead you to make use of re-used concrete components?

[Checkboxes:

-Approval of an engineer

-Financial discount

-Certificate of conformance

-LEED credit

-None of the above

-Other (please specify)]

Appendix A: Survey Content

Question: In percentage, how much on average do you estimate the total design and construction cost of a reinforced concrete structure would increase if it were intentionally designed for disassembly so that its components could be re-used in the future?

[Slider: 0-100%]

***Question:** In your view, what are the main obstacles to the re-use of concrete structural components in construction? Please place **most challenging first** and **least challenging last**.

[Ranking:

-Technical challenges

-Logistical challenges

-Economic challenges

-Aesthetic concerns

-Liability concerns

-Public perception

*Optional N/A tick box available]

Question: Is there another obstacle(s) you believe we didn't include in the previous question? If so, please write below:

[Text box]

***Question:** What would be some of the advantages of incorporating re-used concrete components in construction?

[Checkboxes:

-There are no benefits

Appendix A: Survey Content

-Reduced consumption of non-renewable resources

-Reduced greenhouse gases

-Economic benefits

-New business opportunities/revenue streams

-Less burden on landfills

-I don't know

-Other (please specify)]

***Question:** In your view, what type, if any, of structural concrete application would be most suitable for re-use? Which is least suitable? Please place **most suitable first** and **least suitable last**.

[Ranking:

-Building construction

-Dams and canals

-Bridge infrastructure

-Concrete pipes and culverts

-Hydro poles and utilities

*Optional N/A tick box available]

Questions for the Concrete Structure Owners Stream

***Question:** Has your agency had any experience incorporating reclaimed concrete on a previous project?

[Multiple choice: Yes/No]

If “Yes”:

Question: Approximately what percentage of your projects in the last year have incorporated reclaimed concrete?

[Slider: 0-100%]

***Question:** Approximately what percentage of the reclaimed concrete was:

- Re-used (i.e., in its original form)
- Down-cycled (i.e., crushed and used as aggregate or base material)

[Dropdown menu: 0%, 0-20%, 20-40%, 40-60%, 60-80%, 80-100%, or I don't know]

***Question:** For what purpose(s) or application(s) did you use reclaimed concrete? Check all that apply:

[Checkboxes:

-Base material

-Aggregate in concrete

-Non-structural applications (e.g., drainage)

-Residential construction (e.g., apartment building)

-Commercial construction (e.g., office space or warehouse)

-Public infrastructure

Appendix A: Survey Content

-I don't know

-Other (please specify)

***Question:** Was the original source of the reclaimed concrete known?

[Multiple choice: Yes/No/I don't know]

Question: If answered "yes" to the previous question, please specify:

[Single text box]

***Question:** Would you consider using reused concrete (i.e., in its original form, not down-cycled) in future projects?

[Multiple choice: Yes/No/Maybe]

Question: Why, why not, or why maybe?

[Comment box]

If "No":

***Question:** Would you consider using reclaimed concrete (either re-used or recycled) on a future project?

[Multiple choice: Yes/No/Maybe]

Question: Why, why not, or why maybe?

[Comment box]

***Question:** Would you consider using re-used concrete in its **original form** (not down-cycled as crushed aggregate or base material) for future projects?

[Multiple choice: Yes/No/Maybe]

***Question:** Why, why not, or why maybe?

Appendix A: Survey Content

[Comment box]

Questions continued for both “Yes” or “No” responses:

Question: As a percentage, how often do you estimate that a concrete structure is demolished before it is obsolete (i.e., before the end of its functional or structural service life)?

[Slider: 0-100%]

***Question:** Do you consider re-use of structural concrete components for new construction projects to be feasible?

[Multiple choice: Yes/No/I don't know]

***Question:** In your view, what are the main obstacles to the re-use of concrete structural components in construction? Please place **most challenging first** and **least challenging last**.

[Ranking:

-Technical challenges

-Logistical challenges

-Economic challenges

-Aesthetic concerns

-Liability concerns

-Public perception

*Optional N/A tick box available]

Question: Is there another obstacle(s) you believe we didn't include in the previous question? If so, please write below:

[Text box]

Appendix A: Survey Content

***Question:** What would be some of the advantages of incorporating re-used concrete components in construction?

[Checkboxes:

- There are no benefits
- Reduced consumption of non-renewable resources
- Reduced greenhouse gases
- Economic benefits
- New business opportunities/revenue streams
- Less burden on landfills
- I don't know
- Other (please specify)]

***Question:** What is your perception of the quality and performance of re-used structural concrete components?

[Multiple choice:

- Cannot be determined
- Can be determined, but highly variable
- Likely to be significantly inferior to newly constructed components
- Likely to be marginally inferior to newly constructed components
- Likely to be similar to newly constructed components]

Questions for the Concrete Suppliers Stream

Question: How much concrete approximately do you deal with per year (metric ton)?

[Slider 1-1,000,000]

***Question:** Do you currently provide any products or services that incorporate reclaimed concrete?

[Multiple choice:

- No experience with reclaimed concrete
- Experience with recycled concrete aggregates only
- Experience with re-used concrete only
- Experience with both recycled and re-used concrete]

Question: If yes to the previous question, approximately what percentage of the reclaimed concrete was:

- Re-used (i.e., in its original form)
- Down-cycled (i.e., crushed and used as aggregate or base material)

[Dropdown menu: 0%, 0-20%, 20-40%, 40-60%, 60-80%, 80-100%, or I don't know]

***Question:** If there was market interest from your clients and an accessible inventory, would you consider supplying re-used concrete products?

[Multiple choice: Yes/No]

Question: If yes, what do you estimate the average markdown in price would be (if any)?

[Multiple choice:

- No, there are no discounts provided

Appendix A: Survey Content

-Yes, at an average discount of 10% or less

-Yes, at an average discount of 10-30%

-Yes, at an average discount of 30-50%

-Yes, at an average discount of more than 50%]

Question: If not, why so?

[Comment box]

***Question:** In your view, what are the main obstacles to the re-use of concrete structural components in construction? Please place **most challenging first** and **least challenging last**.

[Ranking:

-Technical challenges

-Logistical challenges

-Economic challenges

-Aesthetic concerns

-Liability concerns

-Public perception

*Optional N/A tick box available]

Question: Is there another obstacle(s) you believe we didn't include in the previous question? If so, please write below:

[Text box]

***Question:** What would be some of the advantages of incorporating re-used concrete components in construction?

Appendix A: Survey Content

[Checkboxes:

- There are no benefits
- Reduced consumption of non-renewable resources
- Reduced greenhouse gases
- Economic benefits
- New business opportunities/revenue streams
- Less burden on landfills
- I don't know
- Other (please specify)]

***Question:** What is your perception of the quality and performance of re-used structural concrete components?

[Multiple choice:

- Cannot be determined
- Can be determined, but highly variable
- Likely to be significantly inferior to newly constructed components
- Likely to be marginally inferior to newly constructed components
- Likely to be similar to newly constructed components]

Questions for the Concrete Contractors

Question: How much concrete is reclaimed by your company per year (metric ton)?

[Slider 1-1,000,000]

***Question:** Where does the concrete you recover go?

- Reuse
- Recycle
- Landfill
- Other (please specify)

[Dropdown menu: 0%, 0-20%, 20-40%, 40-60%, 60-80%, 80-100%, or I don't know]

***Question:** For what purpose(s) or application(s) did you use reclaimed concrete? Check all that apply:

[Checkboxes:

-Base material

-Aggregate in concrete

-Non-structural applications

-Residential construction

-Commercial construction

-Public infrastructure

-I don't know

-Other (please specify)

Appendix A: Survey Content

***Question:** What type of establishments are your main customers? Please place **most popular customers first** and **least popular customers last**.

[Ranking:

-Private sector companies

-Government establishments

-Small-scale local projects

-Large-scale projects

-Other

*Optional N/A tick box available]

***Question:** What percentage of concrete components in a decommissioned structure are likely to be salvageable with minimal processing?

[Dropdown menu: 0%, 0-20%, 20-40%, 40-60%, 60-80%, 80-100%, or I don't know]

***Question:** Is there an extra cost to dismantling (taking apart/disassembling) versus demolition (destroying/destructing)?

[Yes/No/I don't know]

***Question:** What challenges are associated with dismantling versus demolition of concrete structures?

[Comment box]

***Question:** What would be some of the advantages of incorporating re-used concrete components in construction?

[Checkboxes:

Appendix A: Survey Content

-There are no benefits

-Reduced consumption of non-renewable resources

-Reduced greenhouse gases

-Economic benefits

-New business opportunities/revenue streams

-Less burden on landfills

-I don't know]

***Question:** Do you know of any projects which featured reuse of concrete components?

[Multiple choice: Yes/No]

Question: If yes, please share below:

[Comment box]

Additional Comments and Feedback

Question: Is there someone else or another institution whom you think we should contact?

Please list below:

[Comment box]

Question: Please place any comments you wish to share with us below:

[Comment box]

Contact Information

***Question:** Do you wish to enter the draw? (Note: if you are interested in being entered to the draw, please fill in your contact information next)

[Multiple choice: Yes/No]

Question: Contact Information (OPTIONAL):

[Fillable Boxes]

Name

Company

Address

City/Town

Province

Postal Code

Country

Email Address

Phone Number

Appendix A: Survey Content

***Question:** If you provided your contact information above, do you give us permission to contact you for additional information for this research study, if necessary?

[Multiple choice: Yes/No]

Appendix B: Supplementary Bridge Content

Bridge Pictures

Pictures presented here are courtesy of Google Maps.



Figure B.1 Tenth Line Road Overpass – Satellite View (Google Maps)



Figure B.2 View on Overpass Showing Five Lanes (Google Maps)

Appendix B: Supplementary Bridge Content



Figure B.3 Side View of Overpass Showing Five Spans (Google Maps)



Figure B.4 Closeup Underside View of Overpass Showing Seven Girders Resting on One Pier (Google Maps)

Bridge Calculations

quickBridge Full Analysis

In Ontario, the CL-625-ONT Truck is used to compute the live loading. For the Excel sheet titled “Truck Definition” in the software, the truck’s number of axles, and their respective coordinate and weights were entered. For the Excel sheet titled “Bridge Geometry”, the bridge’s number of spans, their lengths, the applied uniform loads, and number of divisions for analysis is inputted. In this analysis, there is no uniform load and as such, 0 is entered. As mentioned previously, this analysis is computed four times as follows:

- Spans 1 and 3 in the left to right direction: data from Table B.1 and Table B.3.
- Spans 1 and 3 in the right to left direction: data from Table B.2 and Table B.3.
- Span 2 in the left to right direction: data from Table B.1 and Table B.4.
- Span 2 in the right to left direction: data from Table B.2 and Table B.4.

Table B.1 Truck Definition in the Left to Right Direction for CL-625-ONT Truck for Any Span

Number of Axles	Coordinate (m)	Weight of Axles (kN)
1	0.0	50.0
2	3.6	140.0
3	4.8	140.0
4	11.4	175.0
5	18.0	120.0

Table B.2 Truck Definition in the Right to Left Direction for CL-625-ONT Truck for Any Span

Number of Axles	Coordinate (m)	Weight of Axles (kN)
1	0.0	120.0
2	6.6	175.0
3	13.2	140.0
4	14.4	140.0
5	18.0	50.0

Appendix B: Supplementary Bridge Content

Table B.3 Bridge Geometry for CL-625-ONT Truck for Spans 1 and 3 in Any Direction

Number of Spans	Length (m)	Uniform Load (kN/m)	Number of Divisions
1	36	0	100

Table B.4 Bridge Geometry for CL-625-ONT Lane Load for Span 2 in Any Direction

Number of Spans	Length (m)	Uniform Load (kN/m)	Number of Divisions
1	34	0	100

The shear and moment envelopes obtained from the software are collected in Table B.5. The table contains the envelopes for all spans in both directions of traffic.

Table B.5 Shear and Moment Envelopes for the CL-625-ONT Truck in Both Directions for All Spans With quickBridge

Span	Direction	Shear Envelope	Moment Envelope
1 & 3	Left to Right		
	Right to Left		

Appendix B: Supplementary Bridge Content

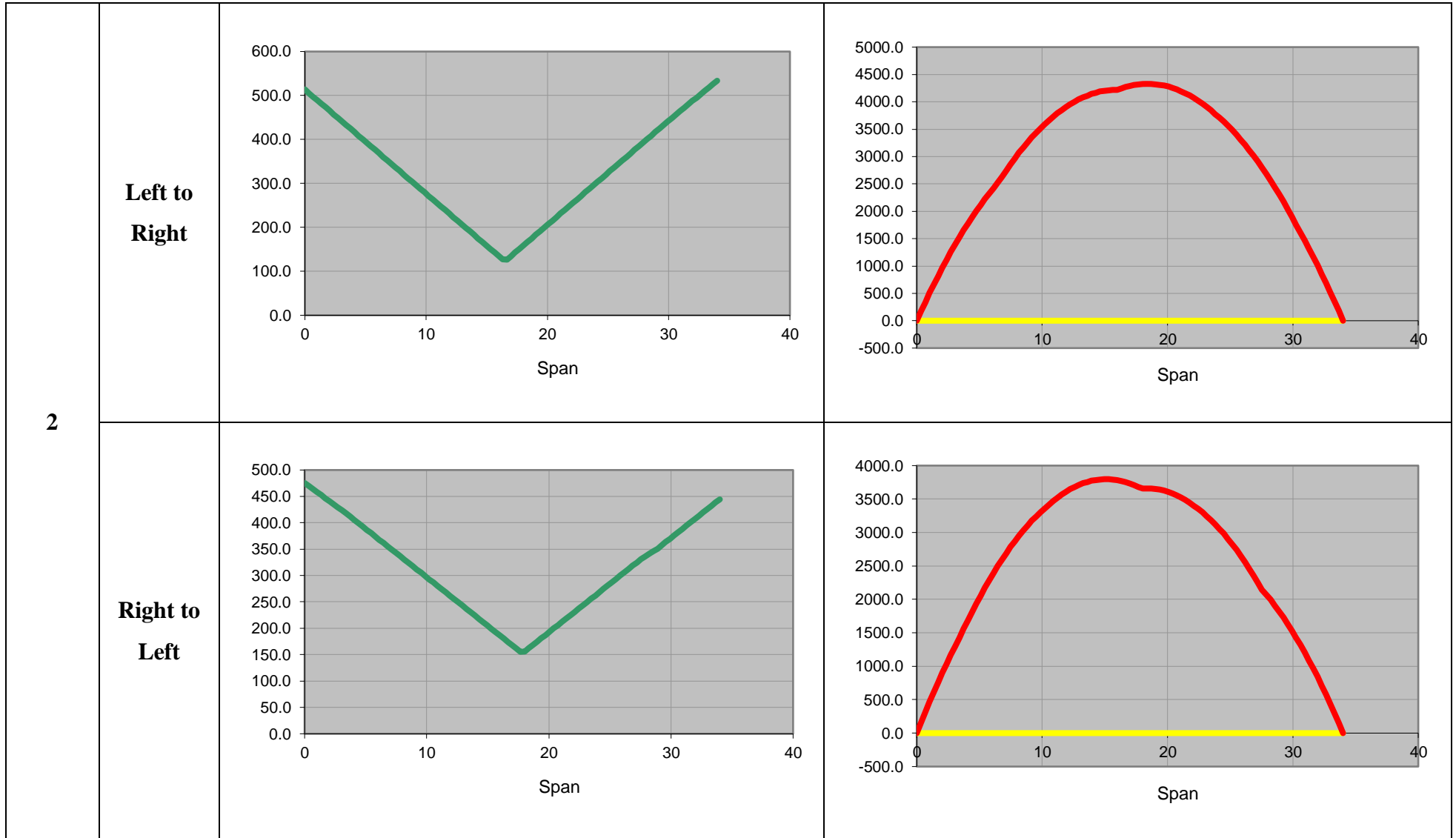

Appendix B: Supplementary Bridge Content

In Ontario, the CL-625-ONT Lane Load is used to compute the live loading. Similarly, like in the previous calculation, for the Excel sheet titled “Truck Definition” in the software, the truck’s number of axles, and their respective coordinate and weights were entered. For the Excel sheet titled “Bridge Geometry”, the bridge’s number of spans, their lengths, the applied uniform loads, and number of divisions for analysis is inputted. Unlike the previous section, in this analysis, there is a 9 kN/m uniformly distributed load. This analysis is also computed four times as follows:

- Spans 1 and 3 in the left to right direction: data from Table B.6 and Table B.8.
- Spans 1 and 3 in the right to left direction: data from Table B.7 and Table B.8.
- Span 2 in the left to right direction: data from Table B.6 and Table B.9.
- Span 2 in the right to left direction: data from Table B.7 and Table B.9.

Table B.6 Truck Definition in the Left to Right Direction for CL-625-ONT Lane Load for Any Span

Number of Axles	Coordinate (m)	Weight of Axles (kN)
1	0.0	40.0
2	3.6	112.0
3	4.8	112.0
4	11.4	140.0
5	18.0	96.0

Table B.7 Truck Definition in the Right to Left Direction for CL-625-ONT Lane Load for Any Span

Number of Axles	Coordinate (m)	Weight of Axles (kN)
1	0.0	96.0
2	6.6	140.0
3	13.2	112.0
4	14.4	112.0
5	18.0	40.0

Table B.8 Bridge Geometry for CL-625-ONT Lane Load for Spans 1 and 3 in Any Direction

Number of Spans	Length (m)	Uniform Load (kN/m)	Number of Divisions
1	36	9	100

Table B.9 Bridge Geometry for CL-625-ONT Lane Load for Spans 2 in Any Direction

Number of Spans	Length (m)	Uniform Load (kN/m)	Number of Divisions
1	34	9	100

The shear and moment envelopes obtained from the software are collected in Table B.10. The table contains the envelopes for all spans in both directions of traffic.

Table B.10 Shear and Moment Envelopes for the CL-625-ONT Lane Load in Both Directions for All Spans With quickBridge

Span	Direction	Shear Envelope	Moment Envelope
1 & 3	Left to Right		
	Right to Left		

Appendix B: Supplementary Bridge Content

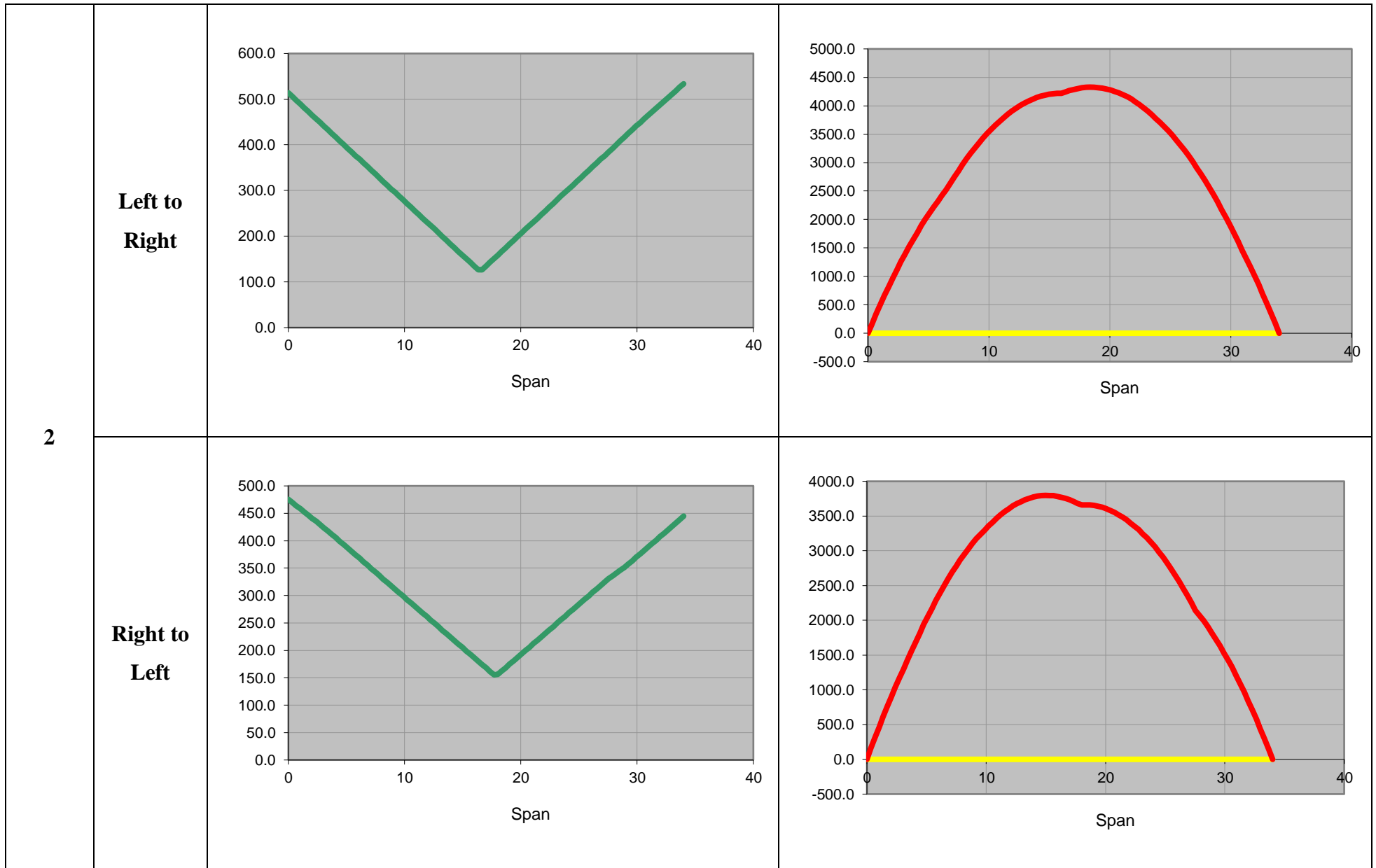

Appendix B: Supplementary Bridge Content

Using the shear and moment envelope graphs collected in Table B.5 and Table B.10, the maximum shear and moment values are extracted. The values are summarized in Table B.11 below. Note that the values in the two sub-columns of the CL-625-ONT Truck column have been increased to account for the dynamic load allowance factor of 0.25 according to the provisions of CSA S6:19. The values in **bold** are the governing values that were used.

Table B.11 Summary Table

		CL-625-ONT Truck*		CL-625-ONT Lane Load	
Direction	Component	Spans 1 & 3	Span 2	Spans 1 & 3	Span 2
Left to	$M_{T_{max}}$ (kNm)	5126.1	4748.8	4727.5	4327.6
Right	$V_{T_{max}}$ (kN)	605.5	594.6	549.5	533.6
Right to	$M_{T_{max}}$ (kNm)	5126.1	4746.6	4727.5	4326.1
Left	$V_{T_{max}}$ (kN)	598.4	594.3	544.9	533.3

*Values adjusted.

Prestressing Steel Contribution Calculation

In Table B.12, the prestressing steel shear contribution for girder A, the shorter non-governing girder, are shared. As noted by the value of V_p , it is smaller than that of girder B presented in Table 4.15.

Table B.12 Prestressing Steel Shear Contribution in Girder A

Number of Strands	Adjacent Distance (m)	Opposite Distance (m)	α (°)	F_{pe} (kN)	$\phi_s F_{pe} \sin \alpha$ (kN)
2	13.15	0.4400	1.92	211.80	6.73
2	13.15	0.5900	2.57	211.80	9.02
2	13.15	0.7400	3.22	211.80	11.30
2	13.15	0.8900	3.87	211.80	13.59
2	14.15	1.0400	4.20	211.80	14.75
2	14.15	1.1900	4.81	211.80	16.86
2	14.15	1.3400	5.41	211.80	18.97
2	14.15	1.4900	6.01	211.80	21.07
				$V_p =$	112.29

Appendix C: Supplementary Building Content

Building Pictures

Pictures presented in Appendix from C are taken during site visit.



Figure C.1 FSS Building from the Front

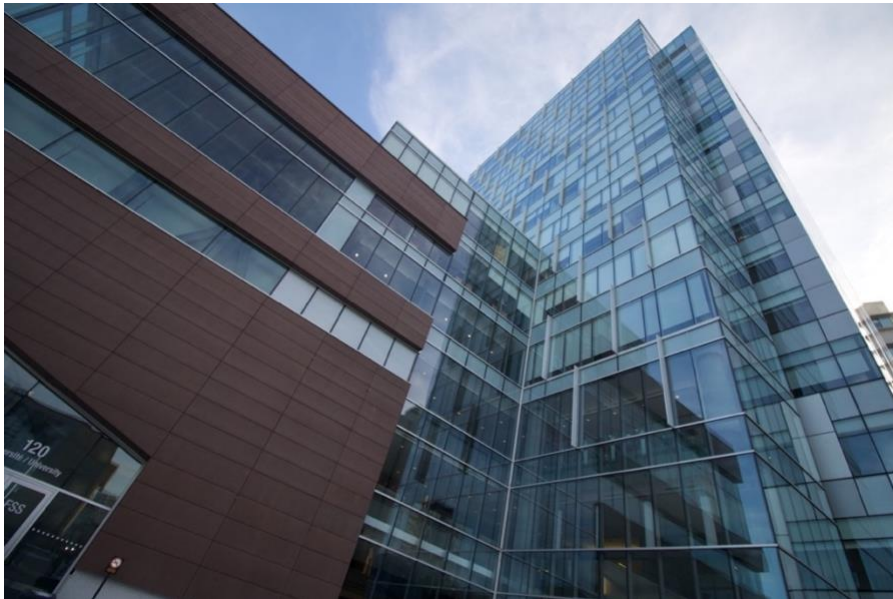

Figure C.2 FSS Building from Side



Figure C.3 FSS Building from Back (Connection to Vanier Hall)



Figure C.4 FSS Building from Inside (Green Wall)

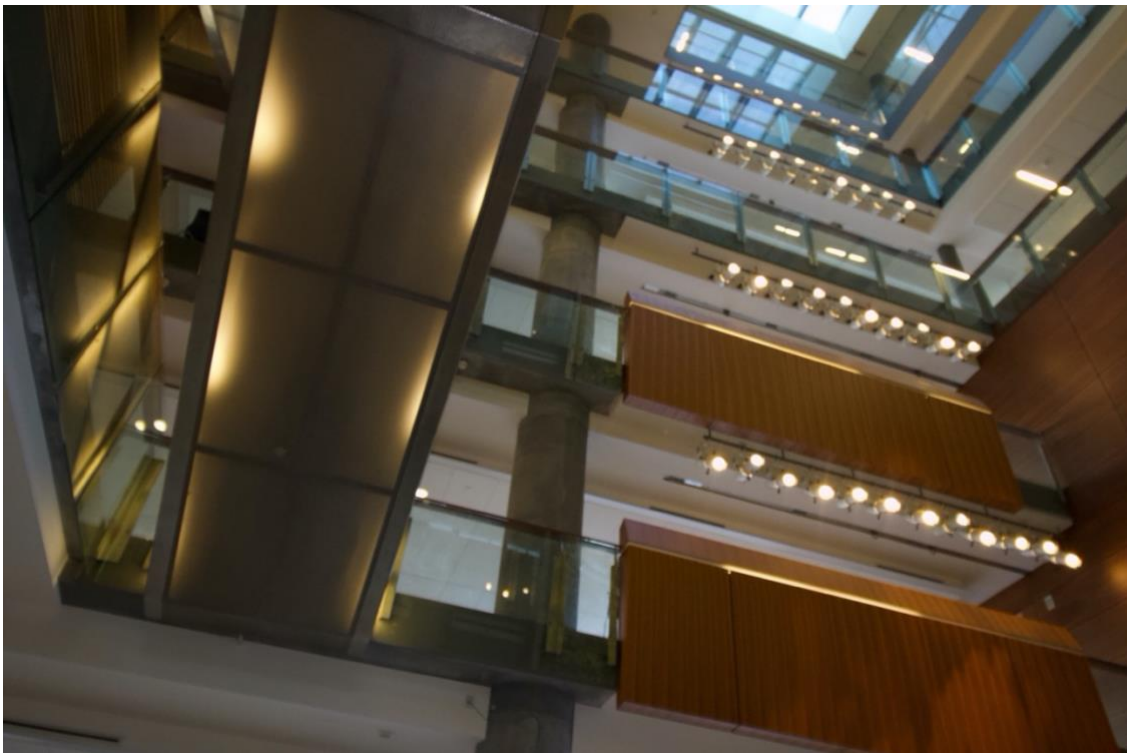

Figure C.5 FSS Building from Inside (Multi-Floor View)



Figure C.6 FSS Building from Inside (Staircase)



Figure C.7 FSS Building from Inside (First Floor)



Figure C.8 FSS Building from Inside (Third Floor)



Figure C.9 FSS Building from Inside



Figure C.10 FSS Building from Inside

Building Plans



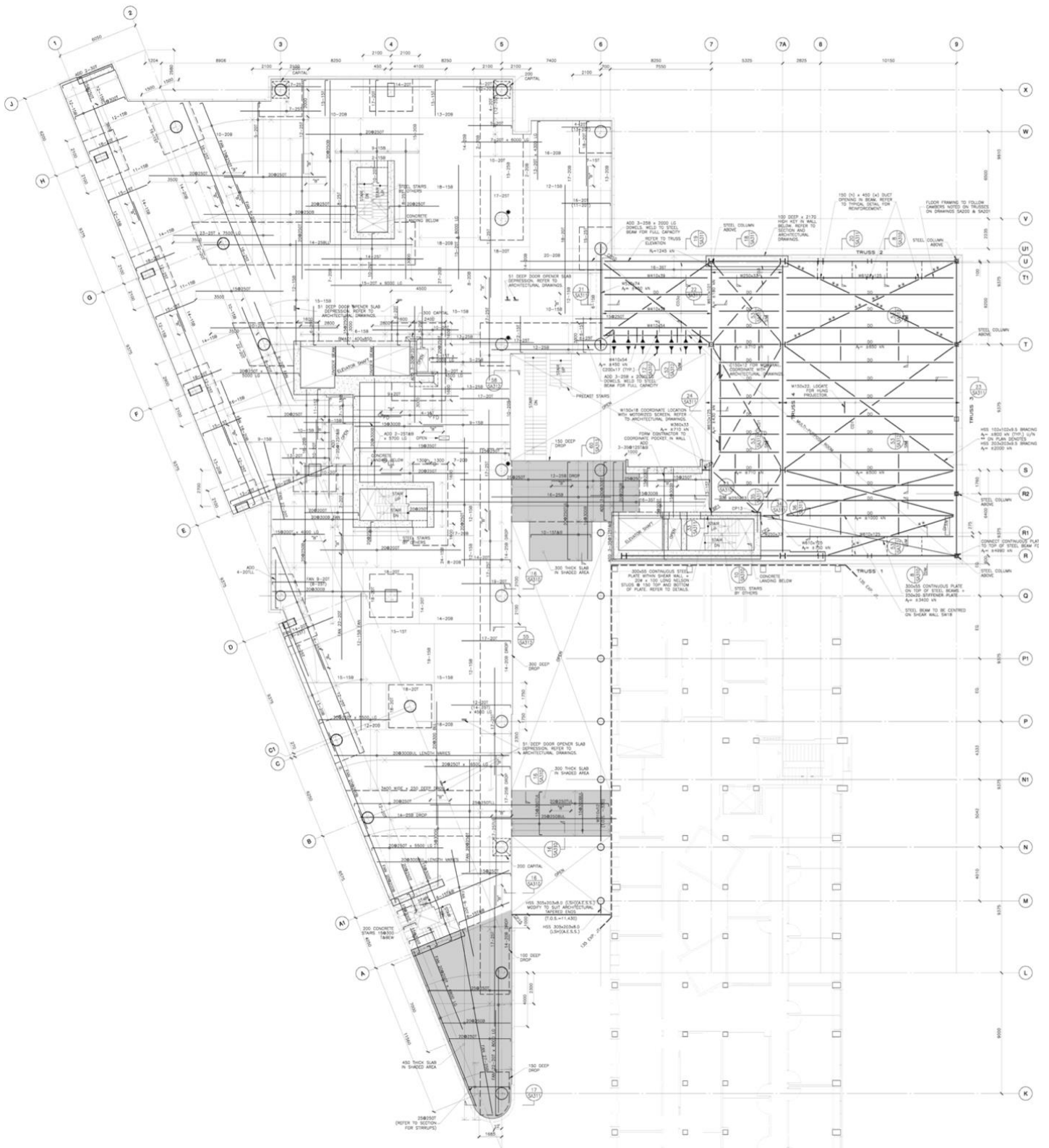

Figure C.13 Fourth Floor Framing Plan

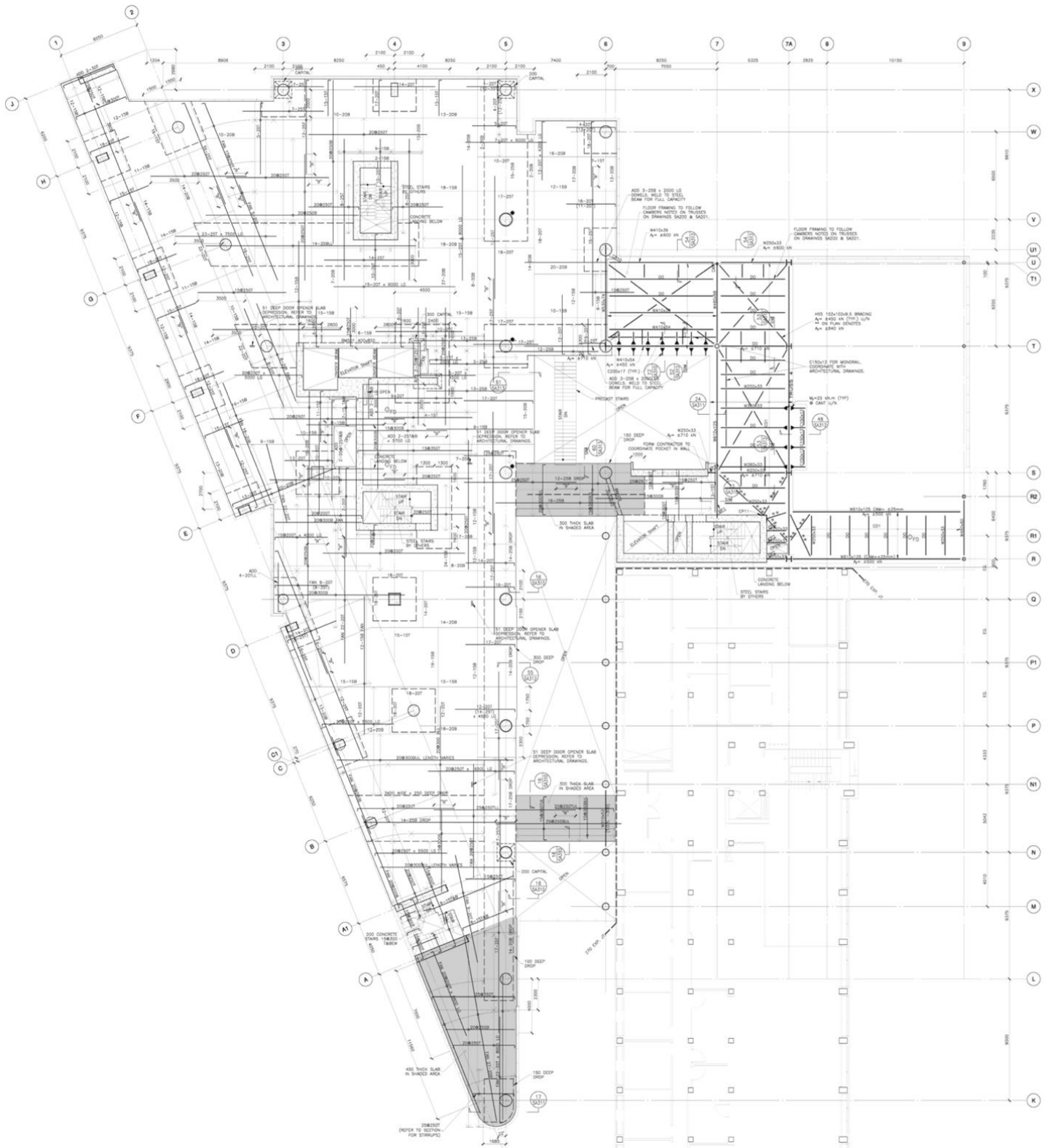

Figure C.14 Fifth Floor Framing Plan

Appendix C: Supplementary Building Content

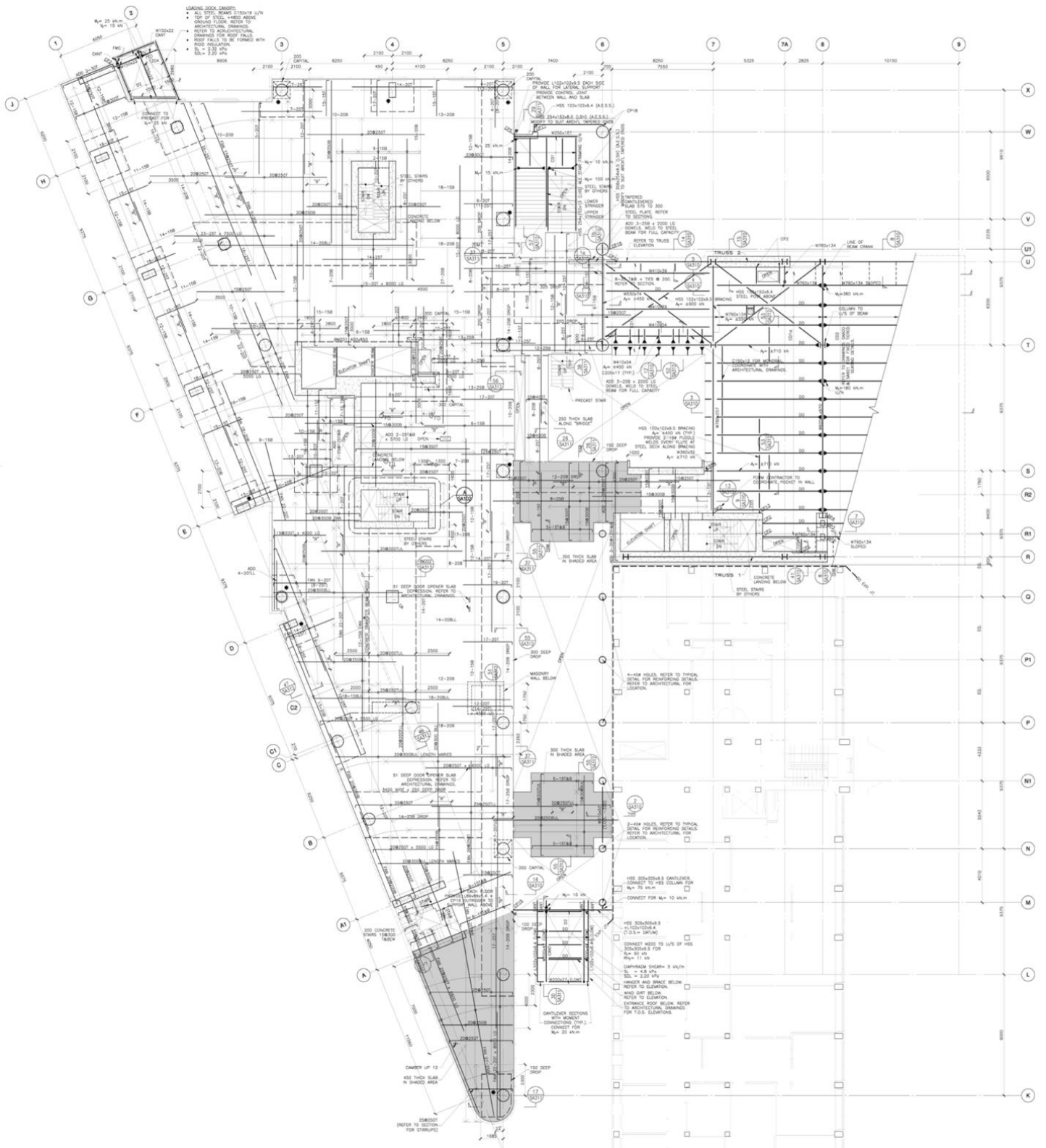

Figure C.16 Seventh Floor Framing Plan

Appendix C: Supplementary Building Content

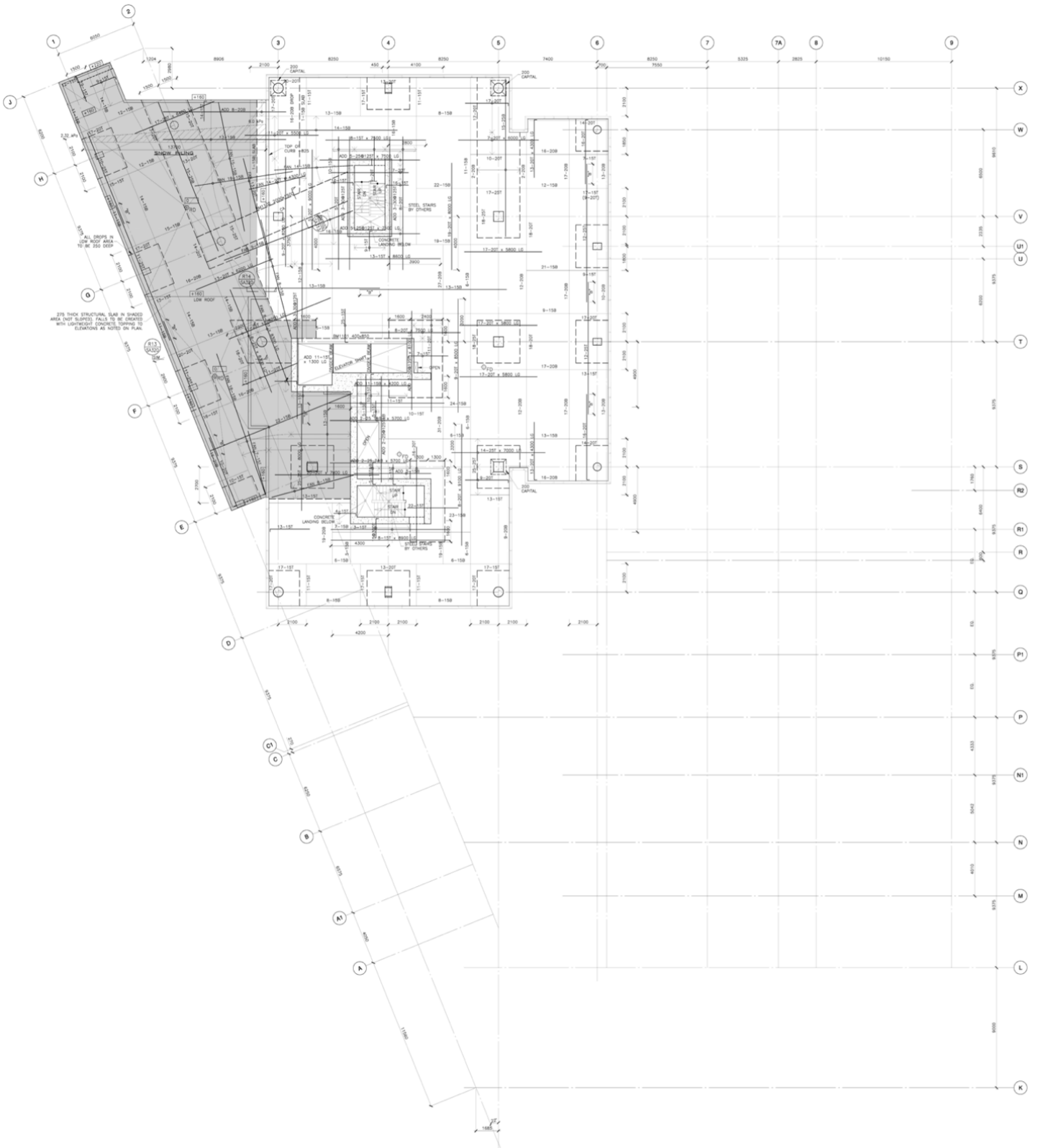

Figure C.18 Eleventh Floor Framing Plan

Appendix C: Supplementary Building Content

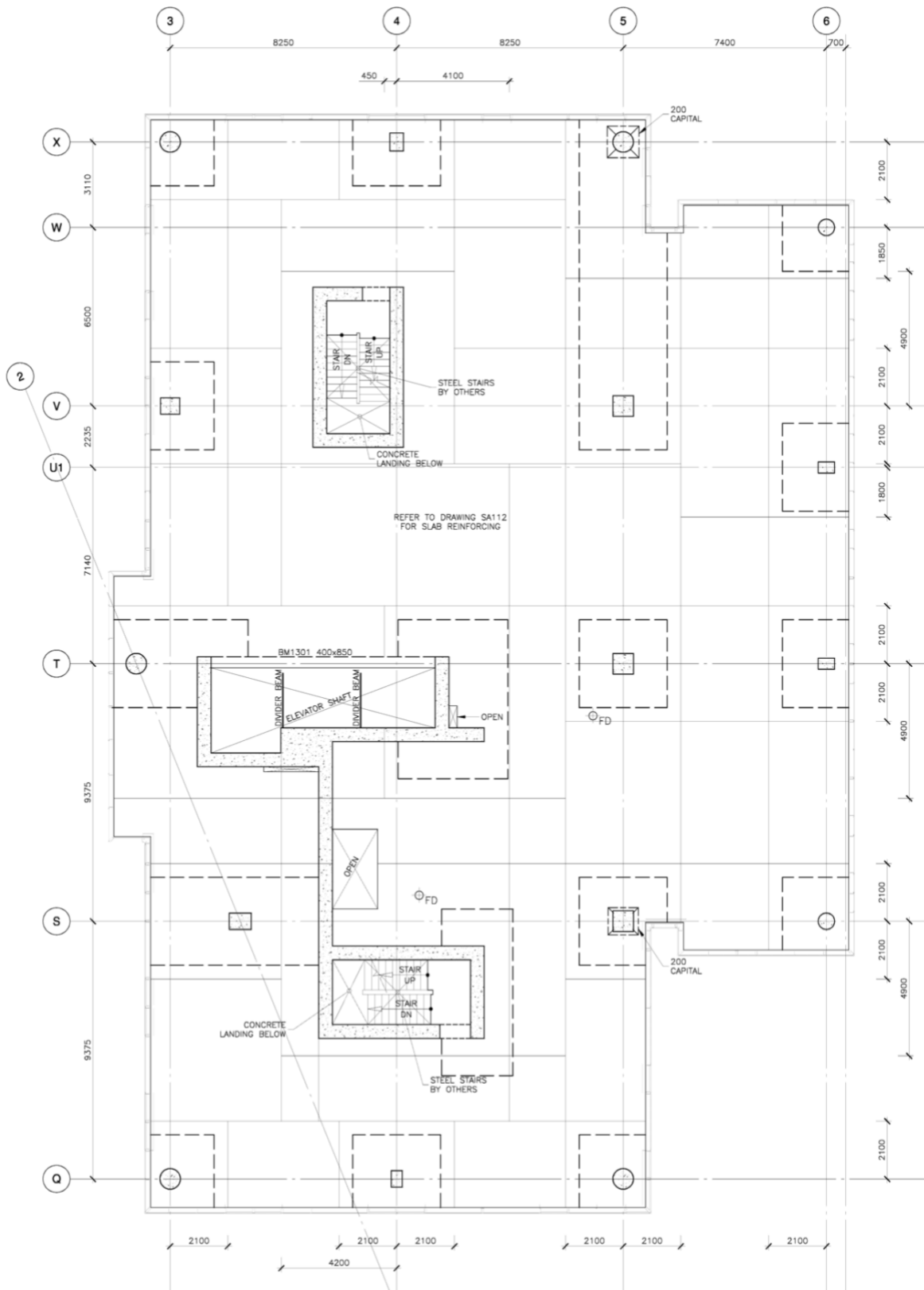

Figure C.19 Thirteenth Floor Framing Plan

Appendix C: Supplementary Building Content

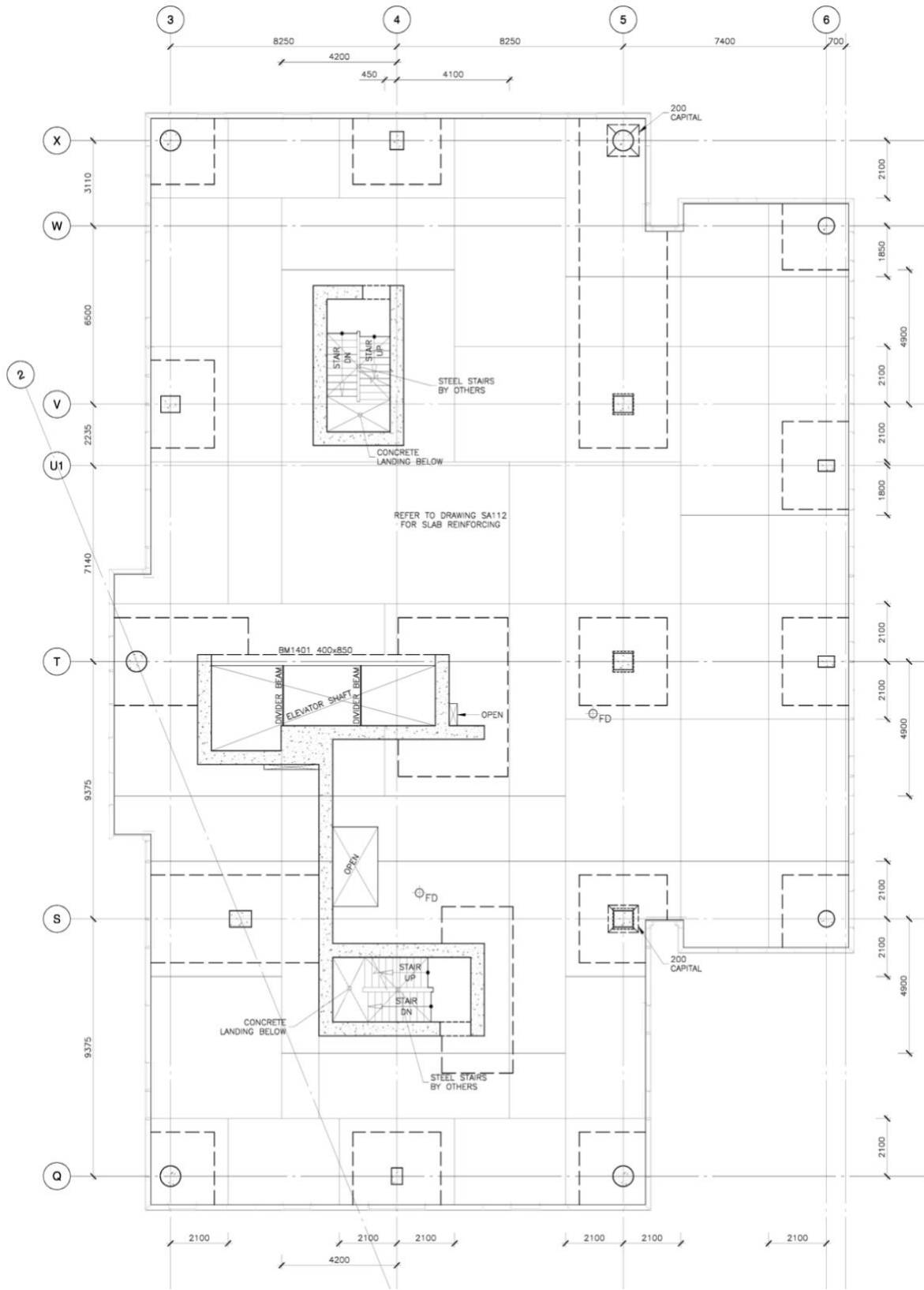

Figure C.20 Fourteenth Floor Framing Plan

Appendix C: Supplementary Building Content

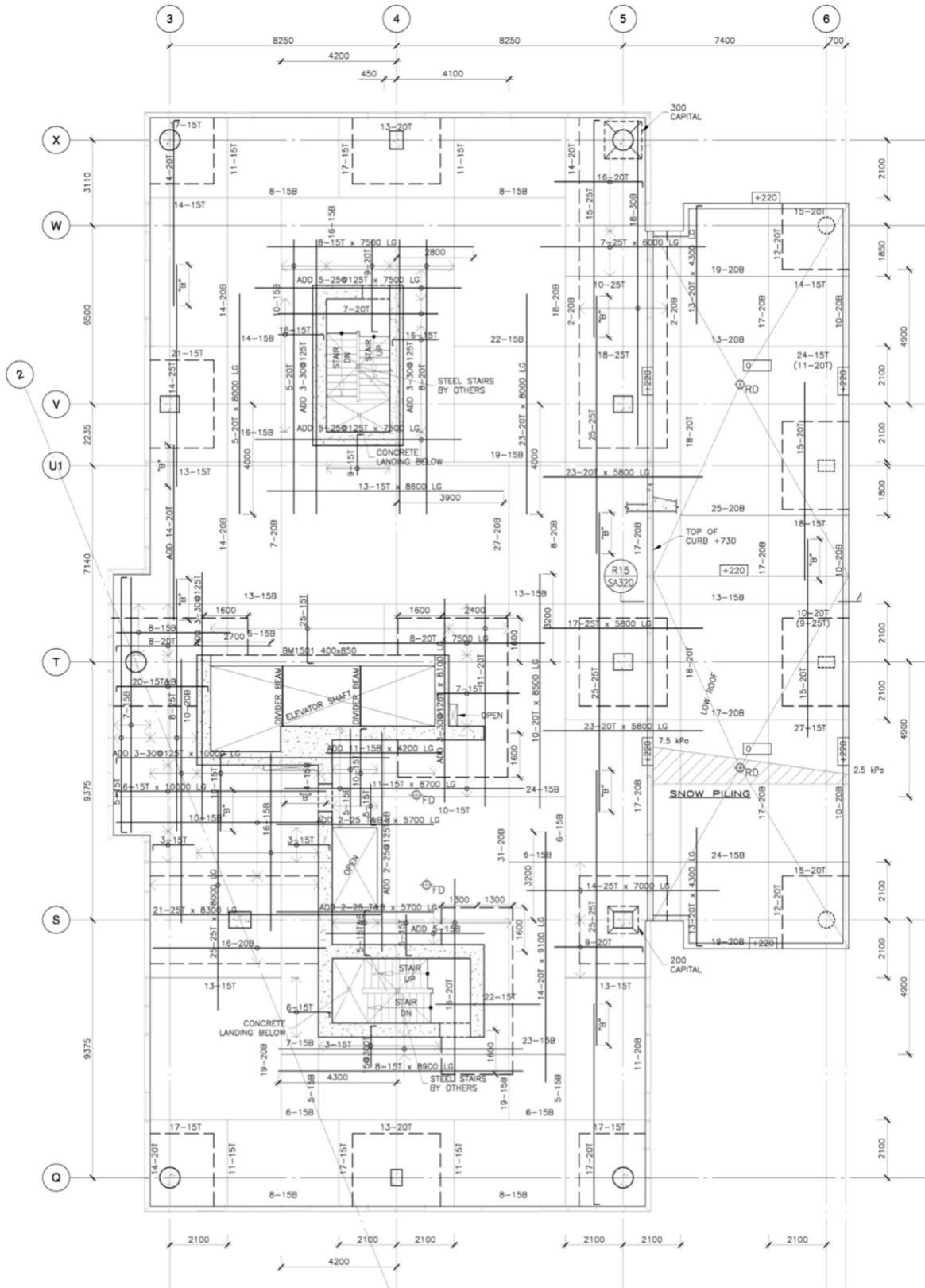

Figure C.21 Fifteenth Floor Framing Plan