

**THE EFFECT AND THE MODE OF ACTION
OF DOWANOL AND A SERIES OF THE NON-IONIC
TRITON ADJUVANTS ON LEMNA MINOR L.**

BY

PIERRE-YVES CAUX

A thesis submitted to the School of Graduate Studies
in partial fulfillment of the requirements for the degree of

Doctor of Philosophy

Department of Biology
Faculty of Science
University of Ottawa
Ottawa, Canada



UMI Number: DC53840

INFORMATION TO USERS

The quality of this reproduction is dependent upon the quality of the copy submitted. Broken or indistinct print, colored or poor quality illustrations and photographs, print bleed-through, substandard margins, and improper alignment can adversely affect reproduction.

In the unlikely event that the author did not send a complete manuscript and there are missing pages, these will be noted. Also, if unauthorized copyright material had to be removed, a note will indicate the deletion.

UMI[®]

UMI Microform DC53840
Copyright 2011 by ProQuest LLC
All rights reserved. This microform edition is protected against
unauthorized copying under Title 17, United States Code.

ProQuest LLC
789 East Eisenhower Parkway
P.O. Box 1346
Ann Arbor, MI 48106-1346

ACKNOWLEDGMENT

The author would like to express his gratitude to Dr. Pearl Weinberger, thesis supervisor, for her patient guidance and helpful advice and encouragement during the course of these investigations.

Special thanks are extended to Dr. David Carlisle, Dr. Roy Greenhalgh, and Dr. Morris Kates who have made up the supervisory committee. The helpful discussions, the extra time and support given by the individual committee members, is gratefully acknowledged. Gratitude is also expressed to Dr. Paul Keddy, Dr. Donald Mortimer, Dr. Art Szabo, Dr. John Sinclair, and Dr. Duncan McLeod, for their helpful suggestions and technical assistance in the different aspects of the study.

Thanks are also extended to the people of the laboratory in which I worked, namely, N. Bertrand, J-F. Gauthier, M-F. Ladouceur, Z. Galehdar, C. Barns, S. Murthy, M. Rea, C. DeChacin, R. Moody, D. Yee and guests, L. Reid, S. Séguin, I. Wisheu and F. Duval. Special thanks are due to Sesh Iyengar, Terry Caunter, Dwayne Moore, Rob Kent, Tom Edge and Al Good. The author acknowledges the technical help provided by André Richer, Jacques Helie, Ben Tchavtchadze and Paul Brunon, in preparing this manuscript, and all indirect help from the support staff.

Acknowledgement is made to NSERC (Grant A1737) for the partial financial support provided during my studies.

The author dedicates this thesis to his family and wife, whose support, understanding and love have made the difference.

ABSTRACT

Adjuvants significantly contribute to many commercial herbicide/pesticide formulations and are often present at concentrations approaching those of the active ingredient. The Canadian Forestry Service¹ is currently testing the adjuvants Dowanol (tripropylene glycol methyl ether), Tritons X-100 and X-114 (alkyl aryl polyether alcohols) as "acceptable" replacement surfactants in the fenitrothion formulation used to curtail the predation of the spruce budworm, Choristoneura fumiferana. This study reports the effects of these compounds and two other more lipophilic Triton adjuvants (Tritons X-15 and X-35) on a common and widespread aquatic vascular plant, Lemna minor L., under laboratory conditions. Also, the perturbant effects of the four Triton adjuvants, namely Tritons X-15, X-35, X-100 and X-114 on total membrane lipids, lipid composition and viscosity was determined to provide biochemical and biophysical determinants of adjuvant effects on membrane integrity.

The parameters monitored during the 14 days exposure included growth (biomass), frond fluorescence and chlorophyll content, ATP content, adenylate charge, conductivity of the test media and specific ion leakage.

Reported concentrations of Dowanol in forest pools after spraying are of the order of 1 $\mu\text{g ml}^{-1}$. Concentrations were

¹ 351 blvd. St-Joseph PVM, Hull, Quebec, Canada, K1A 0C5.

tested up to $965 \mu\text{g ml}^{-1}$ to obtain the threshold concentration. The highest concentration produced significant functional impairment in the plants, which, however, recovered within 2 days in freshwater. Lower concentrations had no measurable effects. The threshold concentration for Dowanol toxicity to Lemna is thus about three orders of magnitude higher than observed field concentrations, and it is concluded that it can be judged to be a relatively environmentally safe adjuvant.

At one $\mu\text{g ml}^{-1}$ Triton (in $500 \mu\text{g ml}^{-1}$ Dowanol carrier solvent), no response on any of the monitored parameters was observed for any of the Tritons and $10 \mu\text{g ml}^{-1}$, yielded no response for X-114. Exposure to $10 \mu\text{g ml}^{-1}$ of the other tested Tritons, however, led to toxic effects such that frond development was depressed 25 to 50%. Exposure to $50 \mu\text{g ml}^{-1}$ of the lower ethoxylates, Tritons (X-15 and X-35), elicited approximately 2-fold greater depression of the parameters assessed than treatments with comparable concentrations of the higher ethoxylate, Tritons (X-100 and X-114). A positive correlation was obtained for the degree of phytotoxicity and the hydrophilic-lipophilic balance (HLB), and partition coefficients of the Triton surfactants. Radiolabelled investigations with two Triton isotopes (^{14}C ring labelled X-15 and X-100) showed X-15 and X-100 to have a bioconcentration factor of 156 and 39, respectively.

In an analysis of the membranes of whole Lemna plants exposed to 40 μM (10-25 $\mu\text{g ml}^{-1}$) Triton adjuvant (in 500 $\mu\text{g ml}^{-1}$ Dowanol), no change was observed in the total lipid content. A decrease in the content of the total phospholipids and a concomitant increase in the content of the galactolipids, however, were observed. Further, a desaturation occurred in the fatty acids of the total lipids, phospholipids and monogalactosyldiglycerides following exposure to all the adjuvants. This accounted for a significant decrease in palmitic and stearic acids and a concomitant increase in oleic, linoleic and linolenic acids when these are compared to the fatty acids in the non treated sets. The fatty acid profile of the digalactosyldiacylglycerols, however, did not differ from controls.

A differential Triton effect was apparent only on phosphatidyl ethanolamine when comparing the fatty acid mole percent of the principal phospholipids of Lemna (PC, PE, PG and PI¹). The hydrophobic adjuvants (Tritons X-15 and X-35) induced a greater unsaturation than the hydrophilic adjuvants (Tritons X-114 and X-100). Membrane dynamics were also perturbed as the anisotropic microviscosity of chloroplast membranes isolated both prior to and after adjuvant treatment decreased.

¹ Abbreviations: PC - Phosphatidyl choline. PE- Phosphatidyl ethanolamine. PG - Phosphatidyl glycerol. PI- Phosphatidyl inositol.

RESUME

On retrouve les adjuvants dans plusieurs formules commerciales d'herbicide et de pesticide. Leur concentration dans ces produits peut facilement atteindre celle de la matière active. Le Service Canadien des Forêts teste présentement les adjuvants Dowanol (éther méthylique du tripropylène glycol) et Triton X-100 et X-114 (alcools alkylaryl de polyéther) afin de les intégrer à la formule du fénitrothion, un insecticide servant au contrôle de la prédation de la tordeuse des bourgeons de l'épinette, Choristoneura fumiferana. Cette étude, effectuée dans le laboratoire, se rapporte aux effets que ces adjuvants et deux autres adjuvants plus lipophiliques (Triton X-15 et X-35) ont sur les plantules aquatiques Lemna minor L. De plus, les effets néfastes que les Tritons ont sur les lipides totaux, la composition lipidique et sur la viscosité des membranes ont été déterminés afin d'avoir un aperçu biochimique et biophysique de l'intégrité des membranes de Lemna.

Les paramètres ou bioessais qui ont été utilisés lors des expériences d'une durée de 14 jours comprenaient: la croissance des frondes, leur fluorescence, leur contenu en chlorophylle et en ATP, la conductivité de la solution minérale et la fuite des ions électropositifs.

La concentration du Dowanol retrouvée sur le terrain après qu'il ait été répandu est d'environ $1 \mu\text{g ml}^{-1}$. De la gamme de

concentrations utilisées (0 - 965 $\mu\text{g ml}^{-1}$), ce ne fut que la plus haute, celle de 965 $\mu\text{g ml}^{-1}$, qui eut un effet néfaste significatif sur les frondes. Cependant, celles-ci ont récupéré rapidement (2 jours) quand elles furent placées dans une solution minérale saine. Le seuil de la concentration du Dowanol requis pour affecter de façon détrimentale les plantules de Lemna est au moins de trois ordres de grandeur plus élevé que la concentration retrouvée sur le terrain. Nous concluons, alors, que le Dowanol est un adjuvant à effet relativement bénin dans l'environnement.

A une concentration de 1 $\mu\text{g ml}^{-1}$ de Triton (dans une solution finale contenant 500 $\mu\text{g ml}^{-1}$ de Dowanol comme transporteur), aucune réponse ne fut observée dans aucun des bioessais. Ce fut le même cas pour le Triton X-114 à une concentration de 10 $\mu\text{g ml}^{-1}$. Par contre, les autres Tritons, à cette dernière concentration, eurent l'effet de diminuer la croissance des frondes de 25 à 50%. Avec une concentration de 50 $\mu\text{g ml}^{-1}$, l'on observait que les Tritons avec une teneur en oxide éthylénique (OE) moindre (X-15 et X-35), accentuaient les effets dépressifs plus que les Tritons avec une teneur en OE plus élevée (X-100 et X-114). Une corrélation fut obtenue pour le degré de phytotoxicité et la balance hydrophilique-lipophilique (BHL), et les coefficients de partage des adjuvants. Le facteur de concentration biologique fut établi pour ^{14}C Triton X-35 et X-100 à 156 et 39, respectivement.

Une analyse des membranes des plantules de Lemna exposées à une concentration de 40 μM (10-25 $\mu\text{g ml}^{-1}$) de Triton (dans 500 μg

ml⁻¹ Dowanol), n'a démontré aucun changement dans la teneur lipidique totale. Une diminution dans la teneur des phospholipides totaux fut accompagnée par une augmentation dans la teneur des galactolipides. De plus, une désaturation des acides gras des lipides totaux, des phospholipides et du diacylmonogalactosylglycerol fut observée dans tout les cas. Ceci a donné lieu à une diminution significative des quantités d'acides palmitique et stéarique et à une augmentation des quantités d'acides oléique, linoléique et linoléique quand ceux-ci furent comparés aux quantités d'acides des plantes témoins. Les acides du diacyldigalactosylglycerol n'ont pas semblé être affectés.

Le pourcentage molaire des acides gras des phospholipides principaux (PC, PE, PG and PI¹), démontrait un effet différentiel sur le phosphatidyléthanolamine. Les adjuvants hydrophobiques (Triton X-15 et X-35) ont induit un plus grand degré de désaturation que les adjuvants hydrophiliques (Triton X-114 et X-100). La dynamique des membranes fut aussi perturbée car l'on a constaté une diminution dans la microviscosité anisotropique des membranes des chloroplastes isolés avant et après la présence des adjuvants.

¹ Abréviations: PC - Phosphatidylcholine. PE- Phosphatidyléthanolamine. PG - Phosphatidylglycérol. PI- Phosphatidylinositol.

TABLE OF CONTENTS

CHAPTER I	1
INTRODUCTION	1
Test organism:	4
Ecotoxicology of xenobiotics:	7
Adjuvant structure and chemico-physical determinants:	8
Hydrophilic-lipophilic balance (HLB) of nonionic surfactants:	11
Octanol/Water partition coefficient (K_{OW}) and solubility:	12
Adjuvants of the fenitrothion formulation:	13
Adjuvant effects:	15
1) Membrane solubilization:	18
2) Cell permeability changes:	20
3) Protein denaturation:	20
4) Effects on photosynthesis:	21
Surfactants and extracellular barriers:	23
1) Cuticles and cell walls:	23
2) Cell membranes:	24
Membrane physiology and fluidity:	26
1) Membrane physiology:	26
2) Membrane fluidity:	29
Desaturase enzyme and model:	31

CHAPTER II	35
<u>MATERIALS AND METHODS</u>	35
Chemicals:	35
Instrumentation:	36
Test organism:	38
Growth conditions:	38
DOWANOL EXPERIMENTS	39
Experimental design:	39
Growth studies:	39
Hemicycle and generation studies:	39
Chlorophyll analyses and change in adenylate charge:	41
Biosorption:	41
TRITON EXPERIMENTS	44
Experimental design:	44
Fronnd numerical counts and biomass:	44
Photosynthetic dysfunction:	45
Ion potential:	45
Octanol water partition coefficients:	45
Separation of total lipids, phospholipids, MGDG and DGDG and the analysis of their fatty acid content:	46
Anisotropy measurements:	48
¹⁴ C Triton uptake:	48
Data evaluation:	49

CHAPTER III	50
<u>RESULTS</u>	50
DOWANOL EXPERIMENTS	50
Growth studies:	50
Hemicycle and generation studies:	50
Total frond chlorophyll:	52
Photosynthetic dysfunction:	52
Ion potential:	53
Adenylate charge:	53
Depuration:	53
Accumulation:	54
TRITON EXPERIMENTS	54
Frond numerical counts and biomass:	54
Physiological toxicity:	55
Total lipid, total phospholipids, MGDG and DGDG analysis:	57
Individual phospholipid analyses:	58
Fatty acid analyses of lipid classes:	59
Anisotropy:	69
¹⁴ C Triton incorporation:	69
CHAPTER IV	90
<u>DISCUSSION</u>	90
DOWANOL EXPERIMENTS	90
TRITON EXPERIMENTS	96
Structure activity relationships:	96
1) Physico-chemical properties:	96

A) HLB:	96
B) K_{ow} :	100
2) Predictive models:	102
General effects on plant physiology:	104
Effects on membrane physiology and fluidity:	106
1) Lipid analysis:	106
2) Membrane fluidity:	111
CONCLUSIONS	114
Suggestions for future research	116
REFERENCES	141

LIST OF TABLES

TABLE 1:	Hydrophilic-lipophilic balance values	12
TABLE 2:	Dowanol growth studies, 10 days after treatment: 96.5, 482.4 and 965 $\mu\text{g ml}^{-1}$ Dowanol; effects compared as % of control	51
TABLE 3:	The effect of 965 $\mu\text{g ml}^{-1}$ Dowanol on R-3 colonies of daughter generations (P - T) transient photosynthetic effects, % of control	52
TABLE 4:	K_{OW} , solubilities and BCF of the adjuvants	56
TABLE 5:	Lipid class concentration in $\mu\text{g/g dw}$ in <u>L. minor</u> following a two week treatment with 40 μM adjuvant	58
TABLE 6:	The effect of Triton adjuvant treatment at a concentration of 40 μM on the fatty acids of the total lipid content of <u>L. minor</u> fronds after 14 days of exposure. Numbers are given as fatty acid mole % of total lipids.	60
TABLE 7:	The effect of Triton adjuvant treatment at a concentration of 40 μM on the fatty acids of the total phospholipid content of <u>L. minor</u> fronds after 14 days of exposure. Numbers are given as fatty acid mole % of total phospholipids.	61
TABLE 8:	The effect of Triton adjuvant treatment at a concentration of 40 μM on the fatty acids of the monogalactosyl diacylglyceride lipid content of <u>L. minor</u> fronds after 14 days of exposure. Numbers are given as fatty acid mole % of monogalactosyl	

diacylglyceride.	63
TABLE 9: The effect of Triton adjuvant treatment at a concentration of 40 μ M on the fatty acids of the digalactosyl diacylglyceride lipid content of <u>L. minor</u> fronds after 14 days of exposure. Numbers are given as fatty acid mole % of digalactosyl diacylglycerides. . .	64
TABLE 10: The effect of Triton adjuvant treatment at a concentration of 40 μ M on the fatty acids of the phosphatidyl ethanolamine lipid content of <u>L. minor</u> fronds after 14 days of exposure. Numbers are given as fatty acid mole % of phosphatidyl ethanolamine.	65
TABLE 11: The effect of Triton adjuvant treatment at a concentration of 40 μ M on the fatty acids of the phosphatidyl inositol lipid content of <u>L. minor</u> fronds after 14 days of exposure. Numbers are given as fatty acid mole % of phosphatidyl inositol.	66
TABLE 12: The effect of Triton adjuvant treatment at a concentration of 40 μ M on the fatty acids of the phosphotidyl choline lipid content of <u>L. minor</u> fronds after 14 days of exposure. Numbers are given as fatty acid mole % of phosphatidyl choline.	67
TABLE 13: The effect of Triton adjuvant treatment at a concentration of 40 μ M on the fatty acids of the phosphatidyl glycerol lipid content of <u>L. minor</u> fronds after 14 days of exposure. Numbers are given as fatty acid mole % of phosphatidyl glycerol.	68

LIST OF FIGURES

FIGURE 1: VEGETATIVE GROWTH CYCLE (<u>Lemna paucicostata</u>) . . .	5
FIGURE 2: DOWANOL STRUCTURE	16
FIGURE 3: TRITON STRUCTURES	17
FIGURE 4: MOTHER GENERATION. Pictoral representation of a mother generation in <u>Lemna minor</u> fronds used for fluorometric analysis.	42
FIGURE 5: DAUGHTER GENERATION. Pictoral representation of a daughter generation in <u>Lemna minor</u> fronds used for fluorometric analysis.	43
FIGURE 6. Chlorophyll content as % control in <u>Lemna minor</u> plants exposed to $965 \mu\text{g ml}^{-1}$ Dowanol	71
FIGURE 7. The effect of $965 \mu\text{g ml}^{-1}$ Dowanol on aggregate generations of <u>Lemna minor</u> (P - T) transient photosynthetic effects as % control	72
FIGURE 8. Leakage of K^+ into the bathing media by <u>Lemna</u> <u>minor</u> plants exposed to $965 \mu\text{g ml}^{-1}$ Dowanol	73
FIGURE 9. Leakage of Mg^{2+} into the bathing media by <u>Lemna</u> <u>minor</u> plants exposed to $965 \mu\text{g ml}^{-1}$ Dowanol	74
FIGURE 10. ATP content as % control in <u>Lemna minor</u> plants exposed to $965 \mu\text{g ml}^{-1}$ Dowanol	75
FIGURE 11. The effect of $965 \mu\text{g ml}^{-1}$ Dowanol on aggregate generations of <u>Lemna minor</u> . (P - T) transient photosynthetic effects as % control, following depuration	76
FIGURE 12. The effects of $965 \mu\text{g ml}^{-1}$ Dowanol on aggregate	

generations accumulation by <u>Lemna minor</u> plants	77
FIGURE 13. <u>L. minor</u> frond number, % control <u>vs</u> adjuvant log concentration in $\mu\text{g ml}^{-1}$, 14 days after treatment . . .	78
FIGURE 14 A). Graph of phytotoxicity parameter as % control <u>vs</u> the hydrophilic lipophilic balance of the Triton adjuvants. Phytotoxicity at $10 \mu\text{g ml}^{-1}$ of the Triton series towards <u>L. minor</u> 14 days after treatment	79
FIGURE 14 B). Graph of conductivity as % control <u>vs</u> the hydrophilic lipophilic balance of the Triton adjuvants. Phytotoxicity at $10 \mu\text{g ml}^{-1}$ of the Triton series towards <u>L. minor</u> 14 days after treatment	80
FIGURE 15. Leakage of Na^+ , Ca^{2+} , K^+ and Mg^{2+} into the bathing media from <u>L. minor</u> plants exposed to $10 \mu\text{g ml}^{-1}$ of the Triton series	81
FIGURE 16. Effects of adjuvants ($10 \mu\text{g ml}^{-1}$) of the fenitrothion formulation on <u>L. minor</u>	82
FIGURE 17 a). Lipid class concentration and total lipid concentration in $\mu\text{g/g dw}$ <u>vs</u> treatment, 14 days after treatment	83
FIGURE 17 b). Lipid class concentration and total lipid concentration in $\mu\text{g/g dw}$ <u>vs</u> treatment as % control, 14 days after treatment	84
FIGURE 18 a). Individual phospholipid concentration in $\mu\text{g/g dw}$ <u>vs</u> treatment, 14 days after treatment	85
FIGURE 18 b). Individual phospholipid concentration in $\mu\text{g/g dw}$ <u>vs</u> treatment as % control, 14 days after treatment .	86

FIGURE 19. Individual phospholipid concentration as % total vs
treatment, 14 days after treatment 87

FIGURE 20. Anisotropy vs treatment, 14 days after treatment
for previously treated and not previously treated
fronds 88

FIGURE 21. ¹⁴C X-35 and ¹⁴C X-100 uptake in μM/g dw vs
cellular fraction, after 14 days 89

APPENDICES

APPENDIX A:	Dowanol molecular formula determination . . .	119
APPENDIX B:	Triton structure determination	131
APPENDIX C:	Extraction efficiencies for Dowanol	136
APPENDIX D:	Triton spectra	137
APPENDIX E:	Triton incorporation in chloroplast	138
APPENDIX F:	Fluorescence Transients	139
APPENDIX G:	Amino acid analysis	140

CHAPTER I

INTRODUCTION

The increase in world technologies has brought to society a heavy dependence on such chemical products as detergents, paints, paint thinners, cosmetics and a range of other household and industrial goods. Man and his environment are regularly exposed to the emulsifying agents and solvents which are added as adjuvants to the major ingredients in these items. Therefore they are subjected to the potential health risk that is created for every new chemical synthesized, or for new adjuvants in chemical formulations.

Adjuvants are added to many commercial herbicide/pesticide formulations to enhance their activity by imparting properties which for example increase the uniformity of application and the penetration rate of the formulations. Adjuvants are often present at approximately the same concentration as that of the xenobiotics (substances artificially introduced into ecosystems which are toxic to the biota of such systems) [1].

Without adjuvants the pure "active" component of a formulation would exhibit only a fraction of its potential activity. Approximately 30-40% of the toxic effects induced by pesticides cannot be attributed to the known specific effects of the

pesticide and consequently may be due to the action of adjuvants or to the synergistic effects with the active ingredients [2]. Generally, formulation experts and manufacturers consider adjuvants to be inert substances and only limited data on possible ecotoxicity are available.

As the exact concentration of the adjuvants in herbicide/pesticide chemical formulations is not revealed by many of the manufacturers, surfactant adjuvants have often been used needlessly at concentrations greater than those required to obtain their maximum efficiency as surface tension (S.T.) reducers [3,1]. Hence in many cases their high concentration has generated ecotoxicological effects on a wide range of aquatic [4,5,6] and terrestrial organisms [7,8]. As these are non-target biota, frequently at the base of many food chains, the importance of evaluating adjuvant toxicity in ecologically sensitive areas should be addressed.

According to the regulations of the Canadian Pest Control Products Act [9], the Governor in Council may make regulations prescribing the form, composition and other standards for control products. The standards require that every control product shall have the chemical and physical composition and uniformity of mix necessary for it to be effective for the purposes for which it is intended. The label of the control product, however, excludes any additional ingredients unless they may affect the treatment of

persons who are poisoned, intoxicated or injured by the control product. In Canada, registration of adjuvants marketed as such is required [10]. In the United States (US), the Environmental Protection Agency (EPA) must approve of the adjuvant if applied to food or feed source. "Registration of surfactants or other products offered as adjuvants in pesticides application is not required under US federal law. Adjuvant must be identified to the EPA and need not be described on the product label. Only six states have identified adjuvants as pesticide products and these are thus subject to registration. Japan and major western European countries will generally require information on the composition and toxicity of products sold for pesticide adjuvants" [10].

Investigations of adjuvants must include several key criteria which are not presently required: They must 1) show clearly whether adjuvants in given pesticide formulations are active or inert, 2) expand knowledge on the chemistry and the biochemical mode(s) of action of adjuvants, and 3) make precise statements relative to specific chemicals. In turn these will lay the basis for a more in depth study of adjuvant effects on biological systems which will ultimately influence the design of future pesticide formulations.

The Canadian Forestry Service is presently testing Triton X-100, Triton X-114 and Dowanol for future use as alternatives to

Atlox and Aerotex. These latter are now banned or in restricted use due to their hazardous environmental side-effects, in the fenitrothion and Bacillus thuringiensis insecticide formulations. To date, tests have primarily been on the search for improved efficiency of pesticide spraying [11].

The present study was undertaken to address the above criteria by:

- 1) Assessing the phytotoxicological behaviour of these adjuvants and two more lipophilic Tritons (X-15 and X-35) at exposure concentrations on Lemna minor L., by looking at a number of different physiological parameters. These include growth (biomass), frond chlorophyll content, ATP content, frond fluorescence, conductivity and electrolyte leakage;
- 2) Following potential ontogenic and chronic effects of these adjuvants;
- 3) Attempting to relate the chemical and physical properties of adjuvants to their biological activities;
- 4) Elucidating targets and modes of action by probing into membrane lipid composition and membrane fluidity.

Test organism:

The test organism, Lemna minor, ("duckweed"), is an aquatic angiosperm from the subclass monocotolidonaceae, order spatiflora and family Lemnaceae. The Lemnaceae are surface dwellers of ponds

lakes and slow flowing streams. They are found world wide in tropical and temperate regions. Reproduction is mostly vegetative. The lack of nutrients is a major inducer of the sexual flowering process [12]. The life cycle and characterization of the colony types in a population of Lemna paucicostata Hegelm 6746, was first described by Datko et al., [13]. A diagram of the vegetative growth cycle of Lemna paucicostata is illustrated in Figure 1 below. For an extensive review of the Lemnaceae, the reader is referred to Hillman [12,14].

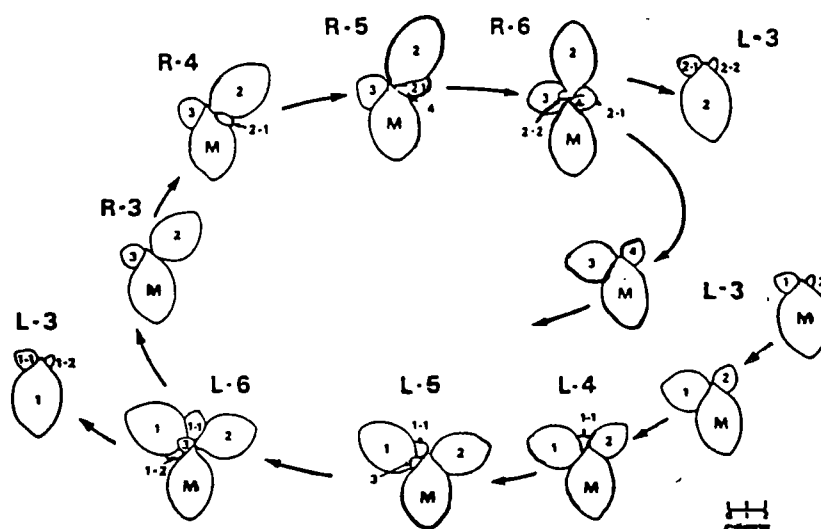

FIGURE 1: VEGETATIVE GROWTH CYCLE (Lemna paucicostata) (from Datko et al. [13])

The R and L represent right and left handedness, respectively. The M represents the mother frond. The numbers define the physiological stage the plant is traversing.

The Lemnaceae support a whole range of organisms including both facultative and obligate insects, hydras, flatworms, snails, water birds, fish (mainly carp) and muskrats. Other plants which associate with the Lemnaceae, are Azolla, Riccia, Eichbornia and Nymphaea. The roots of L. minor serve to anchor the plant to other submerged plant species.

The use of Lemnaceae as an experimental tool for ecological, biological and physiological studies has been recognized since 1961 [12,15]. Important features which have made the organism experimentally valuable are its cloning possibilities, its rapid growth (having a short life cycle open to manipulation), and its ease of maintenance in axenic cultures. These give users of Lemnaceae all the advantages of working with algae and bacteria, together with the relevance of extrapolation to multicellular organisms growing at an air/water interface. Such factors make these multicellular organisms, which are true higher plants, accessible to the many experimental manipulations to which lower organisms are subjected.

Lemna minor like other lemnaceae, fulfill the following requisite criteria for use as an indicator species for pollution [16]: Among these are its sensitivity to a low dosage of a wide range of environmental pollutants, such as heavy metals [16,17], sugars [18] and pesticides [19,20,21]. It is capable of

bioaccumulating the pollutants and shows rapid visual symptomatic pollutant induced effects such as bleaching and loss of buoyancy. In spite of these physiological dysfunctions the plant did not senesce. Further, since it inhabits the air/water interface, it can simultaneously act as a monitor of pollution in both these phases and at their interface. Presently it is being used to test water quality [14].

As the Lemnaceae are rich in protein [12], their use as food for livestock and man has been suggested by growing them on waste or manure stands [22]. It would seem that Lemna may be able to compete with traditional protein crops like alfalfa and soybean [23]. Lemna minor is suggested for use in the biological treatment of sewage and animal feedlots [24].

Ecotoxicology of xenobiotics:

Ecotoxicology is the study of stress responses of organisms to pollutants in the environment [25]. It includes the toxicological behaviour of xenobiotics. The simple introduction of a compound into an ecosystem may evoke a vast array of chemical and biological changes, both in the biota and in their microhabitat. The range of responses depends on the phenotypic plasticity of the organisms, interacting between and among themselves and with their environment. Nutrient limitation, competition and predation are factors included in these interactions. Realistically,

toxicological and ecological information are required to predict the risk factor involved in a particular ecosystem from xenobiotic exposure. Because of the lack of understanding of the physiological and biochemical responses induced by xenobiotics, emphasis in the toxicological assessment has been placed on the whole organism, once the damage is evident (eg. morphological aberrations, growth and reproduction and survival rates). In order to evaluate the biological and chemical toxicological information better, there is a need for increased knowledge of chemical behavior and biological mode of action. Once this detailed knowledge is available, warning and prevention measures become possible.

One way to isolate single chemical effects is to control all the climatic and environmental parameters and use test organisms in their exponential growing phase. These organisms show healthy and vigorous growth before they are exposed to the stress of the test chemical(s).

Adjuvant structure and chemico-physical determinants:

Adjuvants are mostly surface active agents with a wide range of applications as wetting agents, detergents, emulsifiers/dispersants spreading agents, foam reducers, solubilizers and penetrants. They can also increase the efficiency of storage and facilitate the dilutions of formulations into their final aqueous

spray mixtures [26]. They may be used to increase droplet spreading on foliar surfaces, to reduce solvent evaporation rates [27], to increase residence time of herbicide on foliage and increase the specificity of herbicide sites of action [26]. These adjuvant applications have the effect of optimizing the physical properties of the main ingredient in formulations.

The composition and properties of surfactants are quite varied. Chemically they are grouped into four classes or ionogenic groups, anionic, cationic, nonionic and amphoteric (having both an anionic and a cationic character) [28]. Anionic surfactants are characterised by a hydrophobic moiety such as an aliphatic chain and/or an aromatic group (a substituted benzene or a naphthalene). The hydrophilic moiety is negatively charged and is commonly a carboxyl, a sulfate, a sulfonate or a phosphate. Cationic surfactants share a similar hydrophobic group with the anionic surfactants and are characterized by a positively charged hydrophilic group such as quaternary ammonium, sulfonium, arsonium, phosphonium or iodonium. Nonionic surfactants have a hydrophobic group, such as an alkylphenol together with an uncharged hydrophilic group which may be a polymerized ethylene oxide, a polyhydric alcohol, an ester of polyhydric alcohol or a polyether alcohol. An amphoteric or ampholytic surfactant may take both an anionic or a cationic character depending on the medium in which it is present. If the medium is acidic it takes a cationic character, if it is basic,

an anionic one.

Of the four classes of surfactants, the non-ionic surfactants are the most extensively used [26]. The Triton adjuvants used in this study, are non-ionic surfactants. Dowanol has surfactant properties and is a non-ionized hygroscopic solvent used as a stabilizer in an emulsion.

Because of the impact which chemicals can have on the environment, there is an increasing reliance on physical and chemical properties in predicting their potential behavior in the environment [29,30]. The movement and metabolism of adjuvants in plant systems are closely related to their hydrophilic-lipophilic balance (HLB), their octanol/water partition coefficient (K_{ow}) and their ability to modify interfacial tension [31]. The maximum potential of surfactant for lowering the surface tension and the interfacial tension of an aqueous system is reached at the critical micellar concentration (CMC) range. As the concentration of a surfactant increases, it forms micellar aggregates in which the hydrophilic groups are oriented towards the outside and the hydrophobic towards the inside. Thus, most of the surfactant damage is effected above their CMC (often above $100 \mu\text{g ml}^{-1}$). Surfactant molecules added in excess of the CMC greatly affect the osmotic characteristics of membranes [32]. Effects where concentrations are below the CMC are more subtle [32] and not well documented.

Hydrophilic-lipophilic balance (HLB) of nonionic surfactants:

The hydrophilic-lipophilic balance (HLB) is an indication of the weight given to or the chemical and physical relative effects of the polar and non-polar groups of the surfactant molecule. The HLB is an arbitrary value proposed by Griffin [33] and today it is usually commonly used in the identification of nonionic surfactants. It is an empirical value and not an absolute one. It is used in the selection of emulsifiers for pesticidal formulations to approximate the desired physical properties of non-ionic surfactants (Table 1) [26]. The HLBs for non-ionics range from 1 to 20. A value of 1 corresponds to oleic acid and a value of 20 to potassium oleate. With the molecular weights (M_w) of the moieties one can readily calculate the HLB for non-ionics:

$$HLB = 20 M_H / [M_H + M_L] \quad \text{Griffin [33].}$$

M_H = M_w of hydrophilic segment

M_L = M_w of lipophilic segment

TABLE 1: Hydrophilic-lipophilic balance values and surfactant usefulness [34]

HLB range	Area of general surfactant use
4 to 6	Water in oil emulsifiers
7 to 9	Wetting agents
8 to 18	Oil in water emulsifiers
13 to 15	Detergents
10 to 18	Solubilizers

Octanol/Water partition coefficient (K_{ow}) and solubility:

The octanol/water partition coefficient has been used in a number of useful models to predict the chemical behavior of xenobiotics [35,37]. The partition coefficient gives the equilibrium concentration ratio of an organic chemical, partitioned between an organic liquid (eg. n-octanol) and water [35]. There is thus a negative correlation between the solubility of a compound in aqueous media and its octanol/water partition coefficient.

The concept that physiological toxicity could be inversely correlated with water solubility was first postulated by Crum Brown and Fraser in 1868 [36]. More recently (1980), Zitko and Mcleese [37] stated that the toxicity of chemicals generally

increases with increasing $\log K_{OW}$, but there are many exceptions when a highly specific toxic action is involved. Partition coefficients and bioconcentrations have also often been correlated [35,38,39,40].

Adjuvants of the fenitrothion formulation:

Pesticides are largely applied as water emulsions made from emulsifiable concentrates [41]. A pesticide formulation comprises the pesticide together with an emulsifier and a solvent or carrier. As an example, fenitrothion, O,O-dimethyl O-(4-nitro-m-tolyl)phosphorothioate, is a pesticide that has been used extensively in Canadian forests for the control of the spruce budworm, Choristoneura fumiferana (Clemens). This is the pesticide on which this study concentrates. Several formulations have been used since its introduction in 1969.

Dowanol (a propylene glycol methyl ether) (Figure 2) is presently being used experimentally in aerial application of fenitrothion formulations to Canadian forests. Dowanol is used in the fenitrothion formulation as a cosolvent and its formulation concentration is of the order of $1 \mu\text{g ml}^{-1}$. Other uses of this glycol ether are mostly in cosmetics, all purpose domestic detergents and coupling agents for herbicides and insecticides [42].

Isolated toxicity studies with Dowanol using an alga [43,44], aquatic macrophytes and tree seeds [44] or rabbits, dogs and humans [42] have not indicated any overt toxic effects attributable to Dowanol. The studies, however, were not designed to follow potential developmental/ontogenic effects on the non-target test organism using a range of concentrations and chronic exposures.

One of the previously employed formulations with fenitrothion consisted of: Fenitrothion, Atlox (an anionic detergent) and Aerotex (a high boiling point fuel oil) in a ratio of 12:2:2 w/w/w; in others, the ratio of the adjuvants to pesticide was considerably greater. Currently, the formulations are undergoing modification because of the ban on Aerotex [45] (due to its deleterious environmental side effects) and restrictions on the use of Atlox 3409F [46] (for its viral enhancement coinciding with Reye's syndrome [45]).

Triton X-100 and Triton X-114 (large alkyl aryl polyether alcohols) (Figure 3), are currently being used experimentally as alternative components in the fenitrothion formulation [46,47]. In the present study, investigations on the phytotoxicity of Dowanol and these latter adjuvants (Triton X-100 and X-114) as well as two more Tritons of lower HLB (Triton X-15 and X-35) (Figure 3) were undertaken.

Adjuvant effects:

To date the adjuvants in formulations have simply been considered as inert ingredients. Because of this, government regulatory bodies have not set appropriate guidelines for the use of adjuvants in pesticide formulations. Consequently the exact concentration of adjuvants is not revealed by many manufacturers and adjuvants are often used at concentrations far exceeding their maximal efficacy [28]. Weinberger and Greenhalgh [44], emphasized the need for getting registration procedures adopted for all major adjuvants.

FIGURE 2: DOWANOL STRUCTURE. Tripropylene glycol methyl ether.

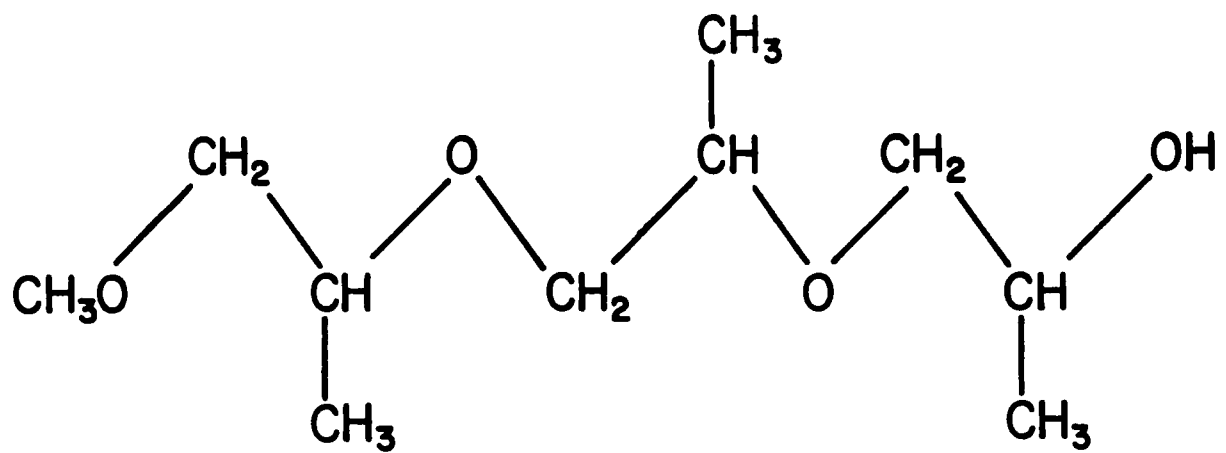
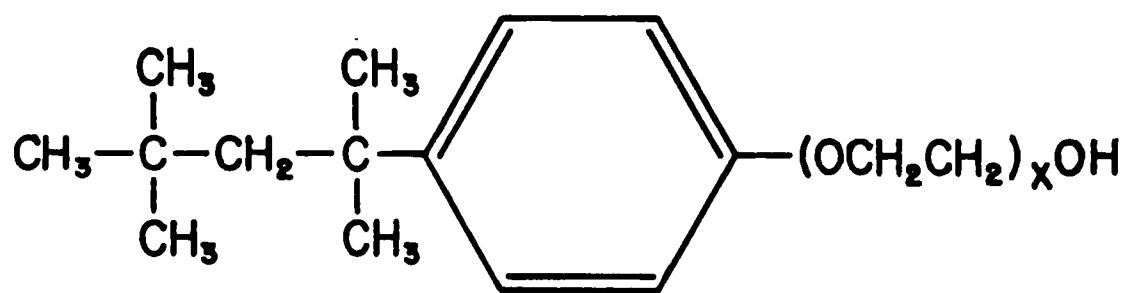

FIGURE 3: TRITON STRUCTURES: x = number of ethylene oxide groups. For Tritons X-15, X-35, X-114 and X-100, $x = 1, 3, 7-8$ and $9-10$, respectively.



The effects of surfactants on plant growth cannot be generalized as these have varying effects on different plants [48]. At the cellular level, high surfactant concentrations are known generally to do one or more of the following: Solubilize membranes and alter cell permeability [49], denature proteins and inactivate enzymes [50], and inhibit photosynthetic activity [51]. Low surfactant concentrations activate enzymes [52], promote the action of auxins [53], and increase growth responses [54], respiration and electron transport [34].

1) Membrane solubilization:

Helenius and Simons [32] extensively reviewed the solubilization of membranes by detergents and stressed that the phenomenon involves a series of modifying factors due to the special structural features of biological membranes. Solubilization of membranes is obtained at high detergent concentrations of Triton X-100 and sodium dodecyl sulphate (SDS) (greater than 5%) and involves the formation of mixed micelles of membrane lipid and mixed micellar structures containing both lipid and protein. At detergent concentrations above the CMC, the separation of lipid from protein is obtained. These concentrations increase the permeability of charged and neutral molecules and this is one sign of membrane lysis [32]. The lysis of red blood cells is described as taking place in five stages. The surfactant monomers 1) adsorb to the membrane, 2) they

penetrate into the membrane, where 3) they induce a change in molecular organization which 4) leads to an alteration in permeability and the osmotic equilibrium, and finally 5) causes the leakage of haemoglobin [32].

Low surfactant concentration effects are more subtle than the gross morphological aberrations evidenced at high surfactant concentrations. Detergents (eg. Triton X-100), may bind to membranes at low concentrations and affect an array of membrane properties, most of which are still not clearly elucidated [32]. Very low concentrations of non-ionic detergents (eg. Triton X-100), seem to stabilize membranes against osmotic, mechanical and acid shock. This may be due to an increase in membrane area [32]. According to Helenius and Simons [32], high affinity binding of anaesthetics to erythrocyte membranes increases the membrane area up to 7%, a result whose causation remains unclear.

Other extensive studies have examined the ability of Triton X-100 and other detergents such as SDS in affecting the solubilization of biological material [32,55] and the isolation of proteins [50,56,57] (eg. receptor proteins, antigens, membrane glycoproteins and other membrane enzymes). These studies were not used to study the potential perturbant/toxicological effects of these surfactants but rather to assess their efficiency as experimental tools in molecular biology.

2) Cell permeability changes:

Adjuvant effects on membranes have often been associated with membrane leakage [58,59,60,61,62,63]. Leakage induced by surfactants is the first indication of membrane perturbation [63]. Detergents of the non-ionic polyethoxy type were found to perturb membrane K^+ pumps in terrestrial non-target plants, as leakage of K^+ was found at the root/soil interface [44]. Concentrations of Triton X-100 below the CMC were found to increase the retention/uptake of solutes in beet disks and above the CMC, to cause a definite leakage of electrolytes and cessation of protoplasmic streaming [62]. Ions and amino acids from the roots of sorghum plants, leaked into the ambient solution after exposure to non-ionic surfactants [59]. The release of amino acids indicates a greater membrane perturbation [59].

3) Protein denaturation:

Detergents at relatively high concentrations generally denature proteins [32,48], selectively reducing enzyme activities [31,50,64]. It has been shown, however, that low concentrations of non-ionic surfactants of the polyethoxy type increase the activity of horseradish peroxidase [52] and fungal glucan synthetase [65]. In the latter, an apparent increase in substrate

accessibility to the enzyme is suggested [65]. Together with this increased accessibility, it has been suggested that movements of cytochromes or other electron transporters might also be facilitated within mitochondrial membranes [66].

4) Effects on photosynthesis:

Triton X-100 (abbreviated in future as X-100) has been used in some studies on photosynthesis [51,67,68]. At low concentrations, 100 μM (0.007% or 50 $\mu\text{g/ml}$), X-100 stimulates the electron transport chain (ETC) and uncouples photophosphorylation in spinach chloroplasts, this being the main cause for the stimulation [51]. Vernon and Shaw [51] speculated that some structural modification of the chloroplast was also involved. At concentrations of 0.01 to 0.02%, the ETC is inhibited because of an irreversible disruption in the oxygen evolving system along with interference of the electron transfer complex [51]. The removal of plastocyanin was also demonstrated. Higher concentrations of X-100 (ie. above .02%), greatly changed chloroplast component positioning. The chloroplast was broken down into smaller active fragments in systems where donor molecules such as TMQH_2 , DPIP_2 ¹ and reduced cytochrome c were added [51].

¹ TMQH_2 : Reduced trimethyl-p-benzoquinone; DPIP_2 : Reduced 2,6-dichlorophenolindophenol.

X-100 at a concentration of 0.005 to 0.02%, when added to aqueous spinach quantosomes (small pigmented lamellar fragments), increased the fluorescence emission. Higher concentration (0.02 to 1%) induced absorption shifts and effective inhibition of the Hill reaction [67]. The increase in fluorescence yields was attributed to detergent interaction with a normally non-fluorescent chlorophyll(a) moiety [67]. Such a phenomenon can only be explained by an uncoupling of photophosphorylation as reported by Vernon and Shaw [51], where part of the energy of the electrons would stimulate the ETC and the rest would be lost as fluorescence.

Low concentrations (0.007%, 0.014%) of X-100, tripled the chloroplast volume in spinach chloroplast suspensions [68,69]. Light-dependent hydrogen ion transport and photophosphorylation were also completely inhibited at these concentrations [68]. Deamer and Crofts [68] suggest that X-100 equilibrates between the medium and membrane phases but does not bind strongly and irreversibly to the membrane as had been suggested by Vernon and Shaw [51]. Further, the authors suggested that the chloroplast swelling which was observed was due either to Triton molecules physically occupying space within the membrane and expanding the total area of the membrane, or by an osmotic phenomenon where the Triton molecules may produce pores allowing the passage of ions into the interior of the chloroplasts. Pore formation was also

suggested by Newman and Jagendorf [69] as an explanation to these experimental results. The swelling led to an inability of the chloroplast to maintain a pH gradient. This would explain the previously observed inhibition of photophosphorylation, hydrogen ion transport and conformational changes [68]. These authors have shown that the loss of all granal structures and the production of closed loop formations from the lamellar membranes take place following exposure to concentrations of 0.014% of Triton X-100. The production of more osmiophilic granules and the swelling of the outer chloroplast membrane, compensating for inner chloroplast swelling, were also noted.

Surfactants and extracellular barriers:

1) Cuticles and cell walls:

Surfactants belonging to the same ionogenic group, vary greatly in their chemistry and have different modes and sites of action [59]. The mechanism by which adjuvants wet plant surfaces or impart their action on plant surfaces has been well documented [70,71]. McWhorter [34] states that although there is increasing evidence for the entry of adjuvants in plant systems, the mechanisms and mode of entry are unknown.

In a terrestrial plant, surfactants have to modify the properties of two lipophilic barriers in order for a systemic

herbicide to penetrate the plant. As a result, the cuticular components and the membrane integrity of the plasmalemma will be altered [72]. The epicuticular wax is perhaps the most important leaf structure in the retention and penetration of herbicidal sprays [71]. Lipophilic adjuvants have been known to alter the composition of epicuticular waxes [73]. Scanning electron microscopy studies, however, have shown epicuticular waxes from seedlings of winter-wheat to be unimpaired after the application of a nonionic surfactant of the polyethoxy type [72]. Shafer and Bukovac [74], demonstrated that Triton X-100 is rapidly sorbed by plant cuticles. This sorption by isolated tomato fruit cuticles was related to various solution characteristics and the presence of waxes in the cuticle. Smith *et al.* [75] refer to "hydrophilic channels" formed by monolayers of surfactants which with the imperfection of the leaf cuticular surface, have fabricated hydrophilic domains which have channel-like properties.

The pectin and cellulose which are part of the epidermal wall are for the most part hydrophilic and facilitate the penetration of water soluble substances. The cell wall, however, offers some resistance to lipophilic molecules [71].

2) Cell membranes:

Deamer and Crofts [68] refer to uncharged pores and not true holes, as probably accounting for the membrane permeability

changes towards small ions. They suggested that these pores likely represent points at which adsorbed X-100 molecules have displaced normal membrane constituents.

According to Schlieper and DeRobertis [76], X-100 conforms to certain requirements for channel formation: 1) completely elongated, the molecule is long enough to span the bilayer, 2) at one end it has a hydrophilic anchor group that could attach to the lipid water interface and 3) it has a hydrophobic portion that could interact with lipid hydrocarbons. A slope of $4.5 \text{ Sm}^{-2} \text{ mM}$ was found for a conductivity versus concentration plot for X-100 and this conductance showed no selectivity between cations and anions [77]. Channel-like properties of X-100 have a relatively sharp cutoff (approx. 40,000 daltons) for leakage of macromolecules through Triton permeabilized red cell ghosts [78].

Fluorescent probes and anaesthetics are hydrophobes that have been subject to membrane studies [79,80,81]. The former of these, generally interacts with the hydrophobic domains of membranes, making them an indispensable tool in membrane work as will be discussed later.

Ecotoxicological studies on the direct implication of surfactants at the molecular level in membrane systems of whole organisms are scarce. Nyberg and Koskimies-Soininen [82,83] studied non-ionic detergents with a view to establish whether

these had an influence on the fatty acid composition of chloroplast membranes, which would ultimately affect growth. Their study with the red algae Porphyridium purpureum, demonstrated that Triton X-100 and sodium desoxycholate increased the saturation grade of the fatty acids of phospholipids, monogalactosyl diacylglycerides (MGDG) and digalactosyl diacylglycerides (DGDG) at a low concentration of 5-15 $\mu\text{g ml}^{-1}$. A slightly higher concentration (20 $\mu\text{g ml}^{-1}$) reversed this effect. The authors suggested that even the slightest amount of detergent pollution in natural waters is a matter which cannot be ignored.

Membrane physiology and fluidity:

In order to examine the possible mechanisms by which detergents may intercalate in the lipids of membranes and have an effect on the membranes of whole organisms, the following section will briefly look at membrane physiology and fluidity.

1) Membrane physiology:

Living cells expend a great deal of energy maintaining the functioning characteristics of membranes, transport mechanisms, ionic balance and membrane potentials, to mention only a few physiological and biophysical functions mediated by external (plasmalemma) and internal membrane systems.

The plasmalemma is the first living barrier around plant cells. Once this is breached or perturbed, consequences of this may affect cellular integrity of normal cell functioning. It is therefore important to examine membrane structures and to determine their active role in the cell in order to perceive possible perturbances induced by an outside stress.

The current dominant theory on the structural organization of membranes is the fluid mosaic model. The model implies a dynamic structure composed of intrinsic proteins, lipoprotein complexes and lipids [84]. Although it is recognized that proteins play a major metabolic role in membranes, emphasis will here be placed on a brief description of the lipid component of membranes as these are the substratum to membrane structure or "mechanical support" to membrane proteins. Further, ourselves and other researchers [32,85] have suggested that lipids are affected by the presence of adjuvants. Adjuvant protein interactions are, however, not excluded.

Membrane lipids are polar lipids. The hydrophobic and hydrophilic moieties of membrane lipids are bridged by or within 1) glycerol, 2) sphinganine derivatives and 3) sterols. When their hydrophilic head is a phosphate, they are either phospho- or sphingolipids. When it is a sugar, these are referred to as glycolipids. The hydrophobic moieties of lipids are saturated or unsaturated fatty acids such as myristic (14:0) and arachidonic

(20:4) acid, respectively. The structure of phospholipids and glycolipids are shown below:

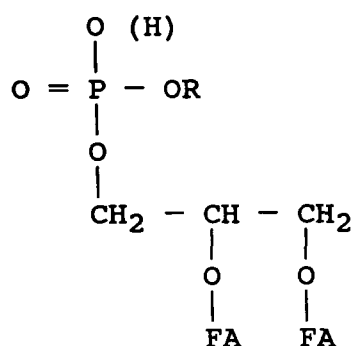

PHOSPHOLIPIDS

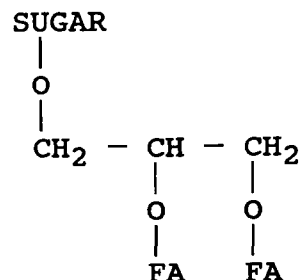

GLYCOLIPIDS

Phospholipids

R = -H	phosphatidic acid	PA
R = -CH ₂ CH ₂ N ⁺ (CH ₃) ₃	phosphatidyl choline	PC
R = -CH ₂ CH ₂ NH ₂	phosphatidyl ethanolamine	PE
R = -CH ₂ CHNH ₂ COOH	phosphatidyl serine	PS
R = - <u>sn</u> -1- <u>myo</u> -inositol	phosphatidyl inositol	PI
R = -CH ₂ CHOHCH ₂ OH	phosphatidyl glycerol	PG

Glycolipids

sugar = monogalactosyl diacylglycerol	MGDG
sugar = digalactosyl diacylglycerol	DGDG
sugar = sulfoquinovosyl diacylglycerol	SL

Lemna minor membranes are mainly composed of phospholipids (63%), together with MGDG (18%), DGDG (13%) and neutral lipids (6%) [86]. The principal phospholipids of L. minor are PC, PE, PG and PI [87] and the minor ones are LPC, LPE (L for lyso), PA and PS. The phospholipids PC and PE of L. minor are rich in linoleic and linolenic acid, whereas the phospholipid PG contains palmitic acid [87]. The principal lipids of chloroplasts are DGDG, MGDG, sulpholipids (SL) and the phospholipid PG [88]. PC, PE and PI are

phospholipids of lamellar systems other than chloroplasts [89]. The MGDG and DGDG of L. minor are very rich in α -linolenic acid which makes up 93% and 82% of their content, respectively [86].

2) Membrane fluidity:

Membrane fluidity is a general term referring to the overall physical state of the membrane lipids [90]. The term has also been used loosely, to encompass a number of parameters, the most important of which are, diffusion, order, packing and permeability [91]. Some scientists [91] describe membrane fluidity at a macroscopic level where the properties studied relate to thermodynamic and geometric changes occurring during membrane phase transitions. Others [91] describe it at a microscopic level, looking at the dynamic or static properties of the individual membrane components. Alois [79,92] gives a detailed review on the concept of membrane fluidity.

The degree of unsaturation of fatty acids (FA) in lipids ie. the number and position of double bonds, the fatty acid length, and the composition of the polar head group are determinants of some intrinsic factors that affect membrane fluidity. This fluidity can be modulated by molecules which penetrate the lipid bilayer such as cholesterol [92]. The phospholipids are responsible for determining the phase separation of membrane lipids [93]. An increase in the chain length of FA will increase

the Van der Waals' attractions between chains and stabilize the ordered gel phase as compared to the disordered liquid crystalline phase [92]. Proteins also play a major role as "changes in lipid composition or phase state can modulate the conformation, activity, and antigenicity of membrane proteins; concomitantly, proteins can control lipid composition by causing phase separation as do divalent cations, and may control the phase state of the lipid by altering its state of ionization. This allows numerous opportunities for control of membrane functions through alterations in both lipid fluidity and organization and protein conformation" [94].

Membrane fluidity is measured by a number of techniques such as: Electron spin resonance, nuclear magnetic resonance, fluorescence polarization, differential scanning microcalorimetry and diffusivity [79,92].

A very useful technique to measure the physical state of the membrane i.e. the order of the fatty acyl chains together with their rate of motion is the fluorescence polarization technique [90]. Even though the Singer-Nicholson model for the structure of a membrane is not fully accepted, one can regard membranes as being substantially two-dimensional with two principal viscosity vectors, one perpendicular, the other parallel to the plane of the bilayer [95,84]. Hence, membrane viscosity is essentially anisotropic, i.e. its physical properties are dependent on the

direction from which these are being measured. The most recent techniques for measuring this microviscosity is with the use of fluorescent probes such as diphenylhexatriene inserted in a ratio of 100:1 (lipid to probe) deep in the lipid bilayer. The anisotropic microviscosity measured in this way can be associated with lipid order and dynamics which together can be thought of as fluidity [90,91].

Desaturase enzyme and model:

The phospholipid desaturase is a membrane bound enzyme consisting of three proteins [161]. A cytochrome b_5 reductase (a flavoprotein, F_p) a cytochrome b_5 and a terminal desaturase. In plants the reaction is as follows:

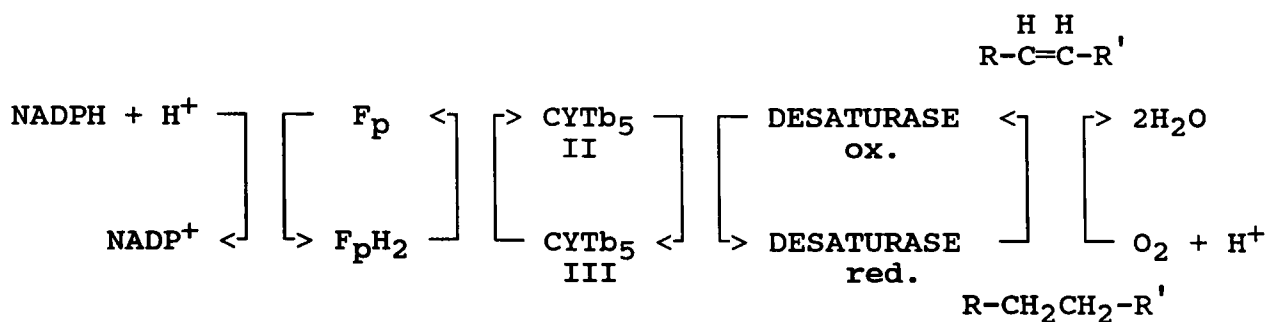

The desaturase enzyme is chain length specific as well as specific for the position in the chain that is desaturated. Examples of these are stearoyl-coa desaturase which is specific for stearic acid and desaturates at position 9,10 to form oleic acid and oleoyl-coa desaturase, specific for oleic acid and desaturates at position 12,13 to form α -linoleic acid. These

enzymes are Δ^9 and Δ^{12} desaturases respectively [161].

The regulation of this enzyme is done by the fluidity of the membrane. Normal membrane activity requires that membranes be fluid. The desaturase enzyme will ensure that a particular fluidity is maintained for an efficient cellular metabolism to take place.

It is hypothesized that the Tritons would intercalate in the phospholipid bilayers of membranes and would have the overall effect of increasing membrane fluidity. By perturbing/compressing and increasing the packing of normal membrane constituent, an enzyme system such as the desaturase enzyme system, would now be in close proximity to all its functional elements and hence would be activated. The hypothesis does not exclude the possibility of surfactant interactions with other enzyme systems. These include enzyme systems regulating the de novo synthesis for glycerophospholipids and glycolipids and other chain modification mechanisms such as the acyl chain exchange mechanisms.

The model shown below was used as the working hypothesis for this research. In this model, non-ionic surfactants at low concentrations are assumed to intercalate into membrane systems.

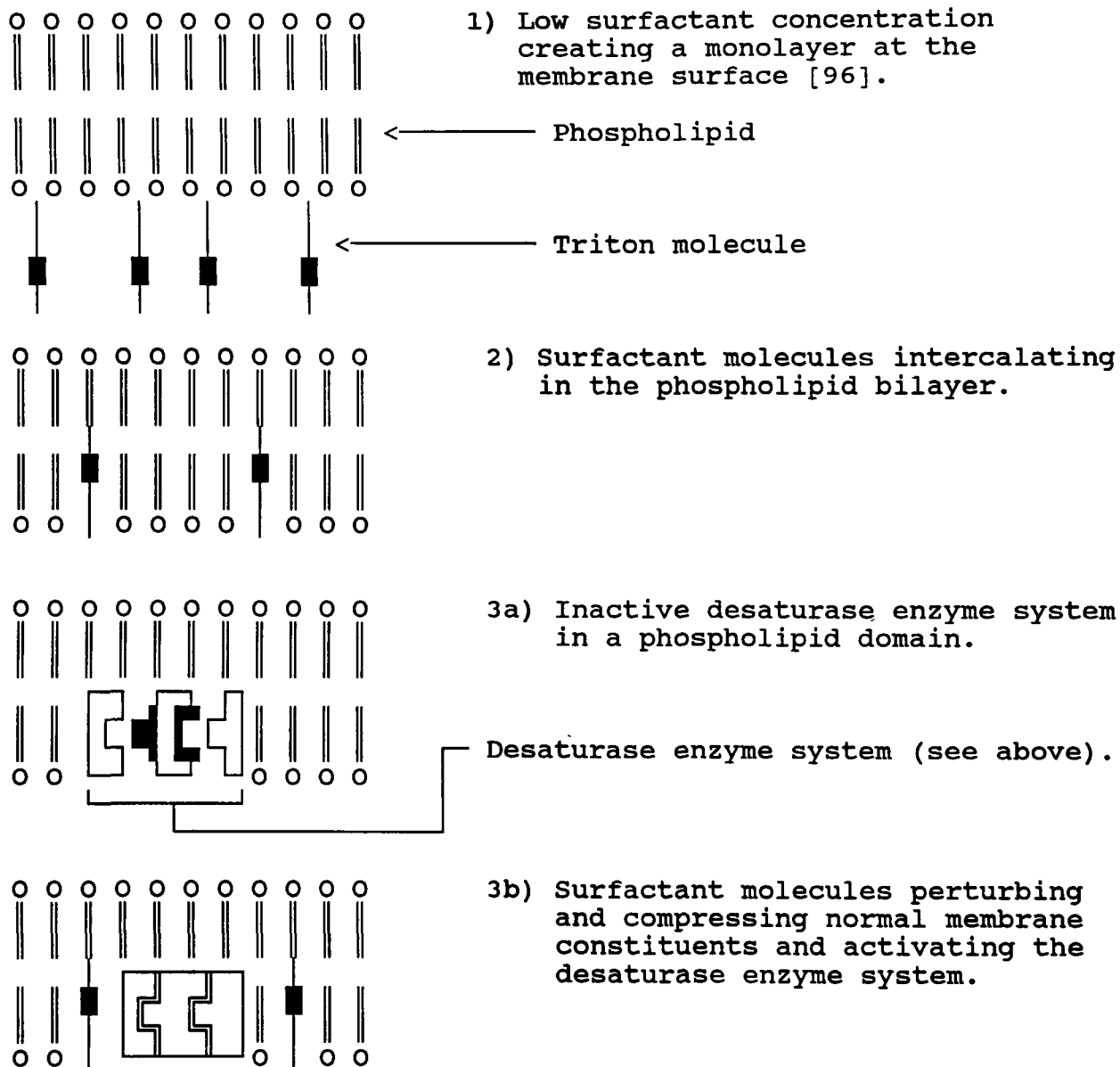

This study was initiated to obtain the essential information required to assess the phytotoxicological behaviour of the Triton series and Dowanol adjuvants on Lemna minor. It was important to obtain plants of identical physiology for a more representative interpretation of this behaviour as well as in the evaluation of the potential ontogenetic and chronic effects. In particular, the following investigations have attempted to relate the biological activities of the selected adjuvants to their chemical and physical properties. Further, the study bears on a mechanistic viewpoint which begins to elucidate targets and modes of action.

The approach the research portion of the thesis takes follows the above context. The framework for the subsequent three sections is set by the materials and methods.

CHAPTER II

MATERIALS AND METHODSChemicals:

Dowanol (a propylene glycol methyl ether), (Appendix A for chemical analysis) was donated by Dow Chemical Co. NJ, U.S.A. Triton X-15, X-35, X-100 and X-114 (alkyl aryl polyether alcohols) (Appendix B for chemical analysis) were obtained from Sigma Chemical Co., St. Louis MO. U.S.A. ^{14}C labelled X-15 and X-100 were donated by the Rohm and Haas Chemical Co., Philadelphia, PA. U.S.A. Aerotex 3470 (a mixture of low boiling point aromatic hydrocarbons) and Atlox 3409F (an ionic detergent) were gifts from Texaco Oil and the Texas Chemical Co., respectively. Luciferin-luciferase substrate-enzyme system (50 mg firefly lantern freeze dried extract in magnesium arsenate buffer) and adenosine 5 triphosphate (FF ATP) were obtained from the Sigma Chemical Co. Stock solutions of potassium, magnesium, calcium and sodium chloride used for atomic spectroscopy were obtained from the Fisher Scientific Co. Toronto, Ontario, Canada. Liquid paper was obtained from the Liquid Paper Co., Toronto, Ontario, Canada. Methylheptadecanoate was bought from the Analabs Chemical Co. North Haven, CT. U.S.A. Lipid standards were purchased from the Supelco Chemical Co. Oakville, Ontario, Canada. Rhodamine 6 G. (R6G) was purchased from the BDH Chemical Co. Toronto, Ontario, Canada. Diphenylhexatriene (DPH) was obtained from the Aldrich

Chemical Co., Milwaukee, WS. U.S.A.

Instrumentation:

A Plant Productivity Fluorometer (Branker model SF-20) from Branker Research. Ltd. Ottawa, Ontario, Canada, was used to monitor the fluorescence emitted by the leaf tissues. The fluorometer was used at a maximum light intensity of 10^4 ergs cm^{-2} and set at a light exposure of 50 s and a gain of 0.8. The L.E.D.² emitted near monochromatic light with a peak wavelength of 670 nm at a current of 50 mA. A conductivity meter (Back Simpson Ltd model No. CND2 11R116N32) served to monitor changes in the ion charge content of the bathing media. A Fisher (model 300) sonicator (35% power, 10 s) served to lyse plant membranes. A Unicam SP 1800 Ultraviolet Spectrophotometer set at a wavelength of 652 nm, was used to measure the chlorophyll content of the fronds. The spectrophotometer (set at 280 nm) was also used to assay the partition coefficient (K_{OW}) for Tritons X-100 and X-114. A Beckman L.S. 3133P liquid scintillation counter, set with an open window of 0-1000 and a gain of 52, was used to monitor luciferase catalyzed ATP-luciferin luminescence. A Packard liquid scintillation counter (model 2000 CA) set for ^{14}C counts (region B) was used to monitor Triton radioisotope incorporation. The determination of the partition coefficient (K_{OW}) for Triton X-15 and X-35, Atlox and Aerotex required the use of a high pressure

²L.E.D. Light emitting device.

liquid chromatograph (HPLC) (Beckman model 324) equipped with a variable wavelength detector operated at 254 nm. High pressure liquid chromatography was performed on an ODS (Atlex) column, 25 cm in length and having an internal diameter of 4.6 mm. The particle size of the stationary phase was 5 μm . The mobile phase consisted of isocratic methanol-water mixture (i.e. 70% methanol, 30% water) for elution. Both the mobile phase and the column were operated at room temperature. The compounds were dissolved in methanol. The injection volume was 20 μl and the flow rate was 1 ml min^{-1} . A Varian AA-175 series atomic absorption spectrophotometer was used for sodium, potassium, calcium and magnesium analyses [97]. Lipid analysis was carried out by thin layer chromatography (TLC) on 200 μm , 20 X 20 glass silica plates purchased from the Fisher Scientific Co. Toronto, Ontario, Canada.

Extraction efficiencies with dichloromethane are given in Appendix C. Gas chromatographic (GC) analysis for Dowanol was performed on a Hewlett Packard model 5880 gas chromatograph equipped with a flame ionization detector (FID). A 2-mm i.d. glass column, packed with 10% Carbowax on 80/100 mesh support, was maintained at an operating temperature of 150°C with 30 ml min^{-1} flow of nitrogen used as the carrier. The injection port and detector were kept at 150°C and 300°C, respectively. For the fatty acid methyl-ester analysis the glass column was packed with Supelco GP SP-2330 on 100/120 Chromosorb WAW and was maintained at 175°C. The injection port and detector were kept at 210°C and

250°C, respectively.

A Varian DMS 200 spectrophotometer set at 650 nm was used to obtain a constant chloroplast concentration at an optical density of 0.375. Anisotropy measurements were made on a Perkin Elmer MPF 44A fluorescence spectrophotometer with excitation and emission wavelengths of 350 nm and 430 nm respectively and slit widths of 5 nm.

Test organism:

We obtained specimens of the test organism, Lemna minor L. (duckweed) from local ponds in the Outaouais region and identified them according to Hillman [12] and Landlot [98]. Axenic stock cultures were obtained following the sterile growth procedure by Bowker et al. [99]. Stocks were axenically subcultured and maintained in 1 L Erlenmeyer flasks.

Growth conditions:

Axenic cultures of Lemna minor L. plants were obtained and grown in 500 ml Erlenmeyer flasks in 200 ml of Bowker's medium [99]. Clonal populations were developed by vegetative multiplication of a single frond inoculum [100]. Plants were grown at 25°C under a constant illumination of 14 watts m⁻² produced by a band of Westinghouse cool white fluorescent lights in a Convicon incubator (model S10h).

DOWANOL EXPERIMENTS

Experimental design:

A stock Dowanol solution of 965 mg ml^{-1} was added to 200 ml of Bowker's medium in volumes of 20, 100 and 200 μl to yield final concentrations of 96.5, 482.5 and $965 \mu\text{g ml}^{-1}$. Ten fronds each were inoculated into 12 flasks, three of which served as controls and nine were exposed to Dowanol, three at each of the concentrations stated above.

Growth studies:

Following treatment with Dowanol, the fronds in each flask were counted on alternate days for a period of 10 days. During this time period fluorometric determinations were made [43], as well as conductivity measurements and the specific ion leakage (as measured by ion uptake) of potassium and magnesium into the bathing media was determined following the method of Garret [97]. In addition, fresh and dry weights of each individual plant in each treatment set were obtained at the end of the study.

Hemicycle and generation studies:

Six mother fronds with no apparent directional growth (neither left nor right side), were separately inoculated into six 3-L

flasks containing 1 L of medium. Following equilibrium distribution of colony types [13], the fronds in each flask were harvested and sorted into either a left (L) side (undergoing the left hand hemicycle of the growth cycle) or right (R) side (undergoing the right hand hemicycle of the growth cycle).

Twelve flasks were then inoculated with one R-3 colony³. Of these, eight were control and four were treatment sets (965 $\mu\text{g ml}^{-1}$ Dowanol). In each set, the mother frond was colour coded with a tiny, barely visible spot of liquid paper at the distal end of the frond, away from the meristematic centers. Four of the controls were left unmarked to test marking effects.

As daughters emerged from the right hand pocket of a meristematic center and reached the R-3 stage, they were excised from the mother fronds and their fluorometric capacity assayed. Mother fronds were returned to the bathing media till the next right handed daughter emerged. The mother generation is illustrated in Figure 4.

Physiological homogeneity of the test plants was obtained by monitoring physiological changes in the fronds of R-3 plants alone. To this end, three R-3 mother colonies marked with a white spot were inoculated into each of 16 flasks. Of these, eight

³ An R-3 colony is undergoing the right hand hemicycle of the growth cycle (see Figure 1). This hemicycle was found to be the predominant cycle as will be discussed later.

provided treated sets containing $965 \mu\text{g ml}^{-1}$ Dowanol and eight untreated controls. As daughters became prominent and reached the R-3 stage, they were colour coded and fluorometric determinations were made on them. The daughter generations are illustrated in Figure 5.

Chlorophyll analyses and change in adenylate charge:

Chlorophyll content was determined using the standard methods of Arnon [101] and Vernon [102] and the change in adenylate charge was determined by the methods of Gower [103] and Patterson *et al.* [104].

Biosorption:

At each time interval (0-240 h), all the plants in each treatment set were harvested separately and the Dowanol content in their tissues extracted with 5 ml 100% methanol and stored overnight at -10°C . Following this the volume of solvent was reduced to 0.5 ml under N_2 gas. The extracts were then centrifuged ($500 \times g$) for 5 min, and the supernatants separately decanted. The debris pellets were re-extracted with 2 ml methanol and centrifuged. The volume of the combined supernatants was reduced to 0.5 ml under N_2 gas for GC analysis.

FIGURE 4: MOTHER GENERATION. Pictoral representation of a mother generation in Lemna minor fronds used for fluorometric analysis.

M is the mother frond
D₁ is the first daughter
D₂ is the second daughter...

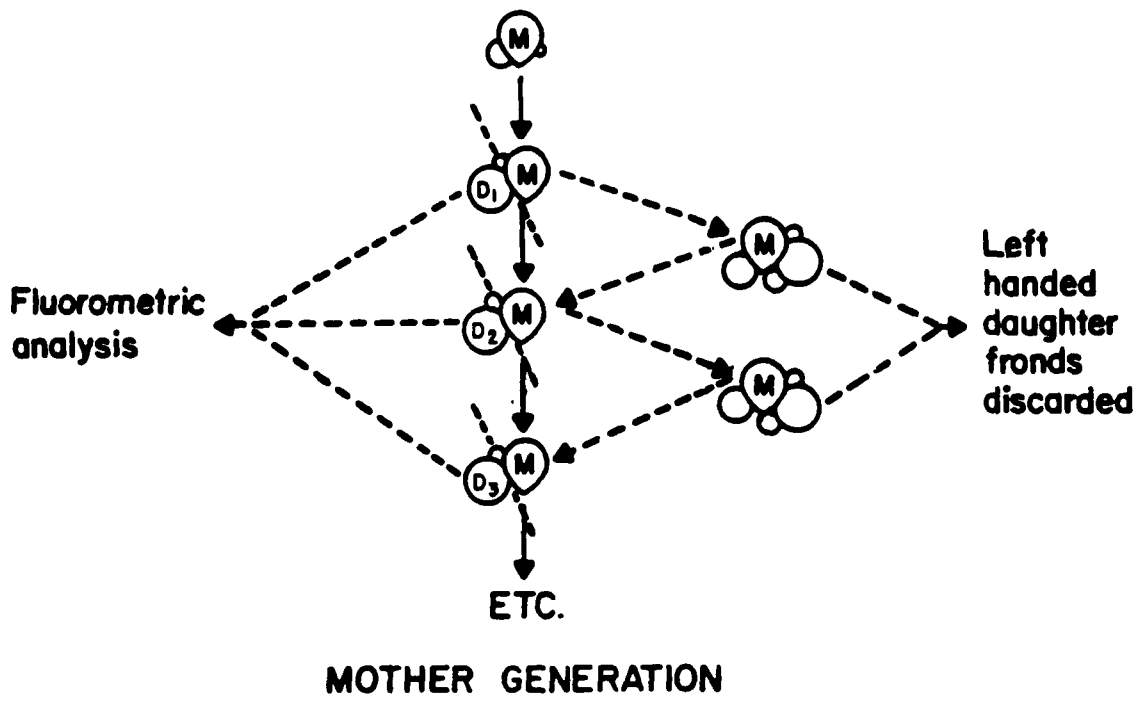
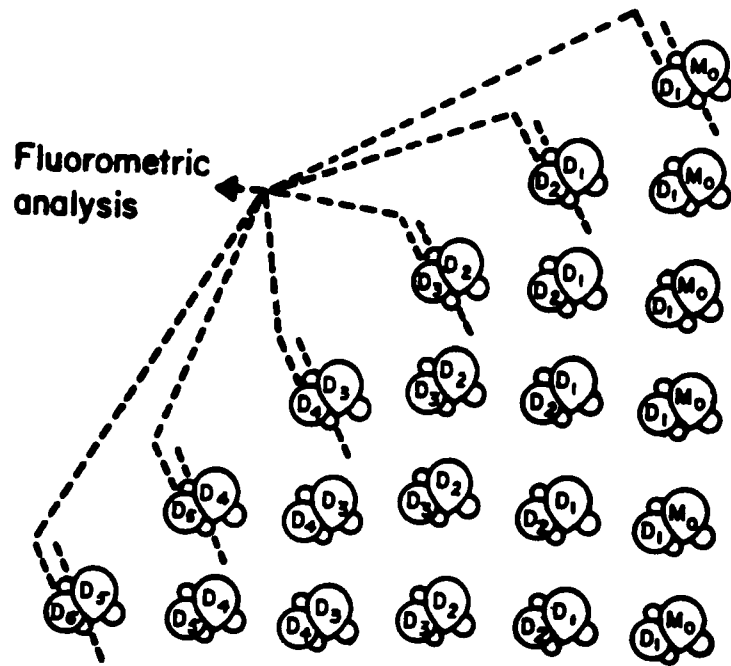

FIGURE 5: DAUGHTER GENERATION. Pictoral representation of a daughter generation in Lemna minor fronds used for fluorometric analysis.

Mo is the mother frond
D₁ is the first daughter
D₂ is the second daughter...



DAUGHTER GENERATION

TRITON EXPERIMENTS

Experimental design:

These experiments were designed to test the effect of the Triton series (X-15, X-35, X-114 and X-100) in the presence of Dowanol. Each Triton adjuvant was separately added to an experimental set for a final concentration of 1.0, 10.0 or 50.0 $\mu\text{g ml}^{-1}$ (in 500 $\mu\text{g ml}^{-1}$ Dowanol), representative of exposure concentrations. 30 fronds were inoculated into each of 20 flasks, four of which served as the control set, four as the Dowanol control set with the remaining twelve exposed to Triton treatments at each of the three concentrations stated above. In concurrent experiments, 8 flasks were used for Aerotex and Atlox treatment sets at a concentration of 10 $\mu\text{g ml}^{-1}$. The data obtained from these latter experiments were to be used in the relation between the phytotoxicity and the K_{OW} .

FronD numerical counts and biomass:

The increase in biomass of the fronds during a 14 day treatment period was monitored by counting the number of fronds and subsequently obtaining their fresh and dry weights (80°C for 24 h to constant weight).

Photosynthetic dysfunction:

Fluorescent response of the fronds from each Triton treatment set was determined in parallel experiments [105] as described previously. Total frond chlorophyll from each Triton treatment set was also assayed using the methods mentioned above.

Ion potential:

The test media of all Triton treatment sets were retained and within 1 h the conductivity and changes in specific ion content (K^+ , Na^+ , Ca^{2+} , Mg^{2+}) were determined following the method of Garret [97].

Octanol water partition coefficients:

One percent (1:99/Triton:H₂O) standard solutions of Tritons X-114 and X-100 were prepared and their absorption spectra scanned (Appendix D) and their absorbance determined at 300 and 296 nm respectively. Increasing Triton solution concentrations were then used to obtain the saturation points, and from this the K_{OW} of each Triton was calculated according to Chiou *et al.* [35].

Separation of total lipids, phospholipids, MGDG and DGDG and the analysis of their fatty acid content:

200 Lemna fronds were utilized in a modified Bligh and Dyer procedure [106,107,108]. Procedures for inoculation and treatment were followed as above. In all there were 72 flasks, 48 of which served as treatment sets, 12 Dowanol control sets and 12 as controls (untreated). Treated sets were separately treated with 40 $\mu\text{mol L}^{-1}$ (10-25 $\mu\text{g ml}^{-1}$) of each of the adjuvants from the Triton series. After a two week period, the fronds from all sets were harvested from the Erlenmeyer flasks and blotted dry. The treated fronds were washed 3 times with deionised distilled water to remove surface contaminants. The fronds were then macerated in a methanol-chloroform-hydrochloric acid solution $\text{CH}_3\text{OH}:\text{CHCl}_3:0.2\text{N HCl}$ (7.6 ml) (2:1:0.8 v/v/v) for total lipid extraction. The 0.2N HCl was added to enhance the extraction of phospholipids [108]. The solution was stirred vortically for 15 sec and left undisturbed for 1 h at room temperature (22°C). The solution was then centrifuged (700g, 15 min). The above procedure was repeated once for the debris pellet and the two supernatants were combined. A two phase system was obtained by adding chloroform and water to obtain a methanol:chloroform:water ratio of 1:1:0.9 (v/v/v). The mixture was gently mixed and centrifuged (700g, 10 min). The chloroform phase (bottom) was separated from the methanol water phase (top) with a pasteur pipette. The chloroform phase was neutralized (pH 7) with 0.3N NH_4OH in methanol.

The lipid classes were first separated from each other by thin layer chromatography (TLC), using a solvent system acetone:acetic acid:water, (100:2:1 v/v/v). The polar phospholipids remained at the origin with the MGDG⁴ and the DGDG⁵ separating thereafter (R_f , 0.36 and 0.25 respectively). Phospholipids at the origin were scraped off and eluted 3 times with a solvent mix chloroform:methanol:acetic acid:water, (50:40:10:1 v/v/v/v). The MGDG and DGDG were scraped off the TLC plates following their localization with referral to standard R_f values obtained through the H₂SO₄ sugar detection method [108].

The principal phospholipids (PC, PE, PG, and PI) were separated by TLC in a solvent system of chloroform: methanol:ammonia, (65:25:5 v/v/v). The phospholipids were identified by co-chromatography with reference standards. The phospholipids were detected on the TLC plates with the help of Rhodamine 6 G (R6G) (aq. solution 0.02%) under near UV light [87]. Immediately following this, the fatty acids were transesterified and methylated [109] as were the fatty acids of the total lipids and total phospholipids, MGDG and DGDG. All lipid classes were quantified by gas chromatography with the use of an internal standard, methylheptadecanoate [86].

⁴MGDGs: Monogalactosyldiacylglyceride

⁵DGDGs: Digalactosyldiacylglyceride

Anisotropy measurements:

Following a two week treatment period with $100 \mu\text{mol L}^{-1}$ media solution of each separate Triton adjuvant, chloroplasts from treated and untreated plants were isolated according to the method of Thomson and Moeller [110] (Absorption spectrum Appendix E). The fronds were homogenized in an isolation medium [10 mM sodium pyrophosphate, 0.33 M sorbitol, 5mM MgCl_2 (pH 6.5) and 2mM L-ascorbic acid], filtered through cheese cloth and the filtered homogenate was centrifuged ($5,900 \times g$) and the pellet redissolved in a resuspension buffer [50 mM HEPES, 0.33M sorbitol, 1 mM MgCl_2 and 2 mM Na_2EDTA (pH 7.6)]. The chloroplast concentration of each mixture was standardized by spectrophotometry. A membrane fluorescent probe, diphenylhexatriene (DPH, 1mM in ethanol), was added in a 100:1 lipid to probe ratio. After a 1 h incubation, anisotropic measurements were taken using a fluorescence spectrophotometer according to the method of Martin and Thompson [111].

^{14}C Triton uptake:

Labelled (phenyl ring labelled) and unlabelled Tritons X-35 and X-100 were added separately to an experimental set to a final total concentration of $100 \mu\text{mol L}^{-1}$ of adjuvant. All fronds from treated and untreated plants were harvested 14 days after treatment and their chloroplasts isolated [110]. The radioactivity

at each step of the fractionation procedure was counted by liquid scintillation.

Data evaluation:

All experiments were rerun at least twice at two different time periods. Homogeneity of variance was determined using Bartlett's test [112]. The data was subjected to a one way analysis of variance and a comparison of the main effects [113] at the 0.05 significance level was made. A VM/370 main frame computer and a Commodore PC10-II were used for the statistical analyses. The statistical packages, SAS (statistical analyses system) and SPSS (statistical packages for the social sciences) were used for the analyses of variance (ANOVA). Sigmaplot (Jandel Scientific) was used for the regression analyses.

CHAPTER III

RESULTS

DOWANOL EXPERIMENTS

Growth studies:

The two lower concentrations of Dowanol, namely 96.5 and 482.5 $\mu\text{g ml}^{-1}$, did not affect any of the parameters assayed (Table 2). Exposure to 965 $\mu\text{g ml}^{-1}$ alone provoked significant perturbant effects; the growth rate was significantly reduced by 16% while fresh weights, dry weights and fluorescence were all reduced by approximately 40%. Conductivity remained unaffected.

Hemicycle and generation studies:

The predominant colony type used in this study were initiated in the right hand pocket of the mother frond. Since most of the colonies were traversing their first two growth cycles it was fairly simple to obtain representative samples of constant right handed "R-3" colony type. This describes the stage in development of a mother frond at which two daughter fronds are produced, each in a right hand pocket of the subtending frond (see Figure 1).

The tiny spots of liquid paper (approx. 0.2 mm), used as generation markers, did not affect photosynthetic activity as

measured by fluorometry and no aberrant photosynthetic effects were detected when following the mother generations of control, untreated plants. Following 12 days treatment with $965 \mu\text{g ml}^{-1}$ Dowanol, however, daughter generations experienced a significant 42% decrease in photosynthetic activity (Table 3).

TABLE 2: Dowanol growth studies, 10 days after treatment: 96.5, 482.4 and $965 \mu\text{g ml}^{-1}$ Dowanol; effects compared as % of control

Dowanol ($\mu\text{g ml}^{-1}$)	965	482.5	96.5
	%control	%control	%control
1) Log growth rate	84 s	91 ns	102 ns
2) Fresh weight	62 s	80 ns	102 ns
3) Dry weight	64 s	83 ns	107 ns
4) Fluorometry	55 s	91 ns	105 ns
5) Conductivity	107 ns	109 ns	106 ns

ns- Not significant.

s - Significant at the 0.05 level (t test); degrees of freedom = 4.

In view of the non-significant responses at the lower Dowanol concentrations, the detailed investigations of the following parameters were only carried out at $965 \mu\text{g ml}^{-1}$.

TABLE 3: The effect of $965 \mu\text{g ml}^{-1}$ Dowanol on R-3 colonies of daughter generations (P - T)¹ transient photosynthetic effects, % of control, n = 3 replicates, standard deviations given

Day	3	6	9	12	15	18
P-T	80 ±11	86 ±13	92 ±18	59 ±13	109 ±9	115 ±6

Total frond chlorophyll:

A 35% decrease in chlorophyll content was observed 24 h after treatment. This was followed by a compensation-type transitory increase 10 days after treatment, above that obtained at 0 day (Figure 6).

Photosynthetic dysfunction:

Significant inhibition of photosynthetic activity in Lemna (aggregate of colony types) was evidenced following treatment, (Figure 7). Maximum inhibition (55%) was obtained following 9 days treatment. Following this, full recovery was obtained and was maintained throughout the course of the 28 day experimental period.

¹(P - T): Indicates the difference between the fluorescence value obtained at P and that obtained at T. For a description of the fluorescence transients see Appendix F.

Ion potential:

The data for the potassium (K^+) concentration in the bathing media (Figure 8), indicates a significant leakage (t test, $p < 0.05$) of K^+ ions 14 and 16 days after treatment. The leakage of magnesium (Mg^{2+}) into the bathing media was evidenced 11 to 18 days after treatment but this was not significant at the 0.05 level (Figure 9).

Given these changes in electrolytes, changes in media conductivity were not apparent during the 0 to 28 days experimental period.

Adenylate charge:

Total frond ATP was significantly depressed by 25% following 24 h treatment. Two to eight days after treatment, however, a transitory increase above control levels was obtained (Figure 10).

Depuration:

Following 2 days exposure to $965 \mu\text{g ml}^{-1}$ Dowanol the fronds that were placed in fresh untreated media underwent a prompt recovery (within 2 days) (Figure 11) from the depressed

photosynthetic efficiency obtained previously at this time period (Figure 7).

Accumulation:

Accumulation of Dowanol (22 $\mu\text{g}/10$ fronds), was obtained following 24 to 48 h exposure to 965 $\mu\text{g ml}^{-1}$ (Figure 12). Following this, clearance of tissue-sequestered Dowanol was evidenced at a rate of $-0.035 \mu\text{g}/10$ fronds/h to 14 $\mu\text{g}/10$ fronds after 10 days.

TRITON EXPERIMENTS

FronD numerical counts and biomass:

After a treatment period of 14 days, neither the Dowanol control at a concentration of 500 $\mu\text{g ml}^{-1}$ nor any of the Tritons at concentrations of 1 $\mu\text{g ml}^{-1}$ caused phytotoxic effects in any of the parameters assessed (Figure 13). When the fronds were exposed to the Tritons at a concentration of 10 $\mu\text{g ml}^{-1}$, however, a range of phytotoxic effects was observed. Three of the four tested adjuvants depressed frond multiplication by approximately 25% (Triton X-100) to 50% (Tritons X-15 and X-35) when these were compared to control ($p < 0.05$). Exposure to 10 $\mu\text{g ml}^{-1}$ of the higher ethoxylate, Triton X-114, invoked no apparent depressant

effect on frond number and dry weights (Figure 14a). Exposure to $10 \mu\text{g ml}^{-1}$ of the lower ethoxylates, Tritons X-15 and X-35, depressed dry weights by 40% and 20%, respectively. Following exposure to $50 \mu\text{g ml}^{-1}$, however, all Tritons significantly depressed frond multiplication (Figure 13). The lower ethoxylates (Tritons X-15 and X-35) depressed frond multiplication to a greater extent (85% vs 65%) ($p < 0.05$) than did the higher ethoxylates (Tritons X-100 and X-114).

Physiological toxicity:

Phytotoxicity, as determined by frond multiplication, dry weights, frond chlorophyll content, frond fluorescence, conductivity (Figure 14a & 14b) and electrolyte leakage (Figure 15), decreased with an increase in the hydrophilic lipophilic balance¹ [33] (HLB) of the surfactants. Conductivity and fluorescence responses were the most sensitive indicators of early stress. The lower ethoxylates (Tritons X-15 and X-35) depressed these latter responses significantly, more than did the higher ethoxylates (Tritons X-100 and X-114). Two weeks of exposure to any one of the Triton series led to leakage of K^+ , Ca^{2+} , Mg^{2+} and possibly Na^+ into the test media (Figure 15). The sequence of decreasing effects was Triton X-15 > X-35 > X-100 > X-114. This sequence is the same as that shown by the

¹ The H.L.B. is an arbitrary scale for non-ionic surfactants (from 1-20), 1 is equal to oleic acid and 20 to potassium oleate [33].

phytotoxicity parameters in Figure 14a.

The octanol/water partition coefficients (K_{OW}) for Tritons X-100 and X-114 used in the present study were determined to be 13 and 29, respectively. These, together with the K_{OW} for other adjuvants in some of the fenitrothion formulations are given in Table 4. Phytotoxicity of these adjuvants at $10 \mu\text{g ml}^{-1}$ confirmed the hypothesis that toxicity effects, presently noted, could be positively correlated with the $\log K_{OW}$ of the adjuvant (Figure 16). The higher the $\log K_{OW}$ the greater the phytotoxicity.

TABLE 4: K_{OW} , solubilities and BCF of the adjuvants

COMPOUNDS	K_{OW}	LOG K_{OW}	WATER SOLUBILITY ($\mu\text{MOL L}^{-1}$)	BCF ¹
Dowanol	0.33	-0.48	1.5×10^8	0.66
TRITON X-15	5.5×10^4	4.74	2.44	242
TRITON X-35	1.6×10^3	3.2	4.7×10^2	42
TRITON X-114	29	1.46	1.9×10^5	5.9
TRITON X-100	13	1.11	6.3×10^5	4.0
NONYLPHENOL	9.1×10^4	4.96	1.15	310
AEROTEX	4.0×10^3	3.6	1.23×10^2	67
ATLOX	5.0×10^2	2.7	2.71×10^3	21

¹ BCF: Bioconcentration factor. The ratio between the adjuvant concentration found in the plants and that found in the media. BCF data derived from Lockhart *et al.* [39].

Total lipid, total phospholipids, MGDG and DGDG analysis:

The statistical analyses were performed on the transformed data (arcsine) and are significant at $p < 0.05$ ¹. The data for the lipid composition of L. minor control plants following the 14 days time period has been compared to that of Grenier et al. [86] and reflects a similar lipid profile. These authors obtained, however, a higher percentage of phospholipids, 63% as compared to 53% obtained in this study. In their study, sulfoquinovosyl diglyceride was not identified and hence was not analysed in the present study. The total lipid content in control and Triton treated fronds did not significantly change following a two week treatment period (Figure 17a & 17b, Table 5). The predominating lipid classes in control fronds were the phospholipids (53%), followed by the MGDG (30%) and the DGDG (17%). Following Triton treatment, although not all values showed a significant difference from control, the trend was for a decrease in phospholipid content and an increase in MGDG and DGDG content (Figure 17a & 17b, Table 5). These changes can be related directly to the change in the number of ethoxyl units in the Triton surfactants. The lower ethoxylate Tritons reduce the concentrations of phospholipids present while the higher ethoxylates tend to stimulate the production of MGDG.

¹An ANOVA was performed on the derived data of all treatments, on each of the fatty acids in each of the lipid classes analyzed. A comparison of the means between treatments was included (Tukey multiple range test [111]).

TABLE 5: Lipid class concentration in $\mu\text{g/g dw}$ in L. minor following a two week treatment with 40 μM adjuvant. Standard deviations shown.

LIPID CLASS ¹	-----Treatment-----					
	CONTROL	Dowanol	X-15	X-35	X-114	X-100
TOT. LIP.	213.8 \pm 14	214.1 \pm 1	216.5 \pm 3	219.3 \pm 7	214.7 \pm 3	218.0 \pm 6
PL	48.0 \pm 1	49.2 \pm 3	45.3 \pm 4	47.4 \pm 1	42.6 \pm 4	40.3 \pm 4
MGDG	26.8 \pm 1	24.8 \pm 4	32.1 \pm 2	29.4 \pm 3	31.4 \pm 3	31.7 \pm 1
DGDG	15.8 \pm .2	15.5 \pm .4	18.9 \pm 3	19.8 \pm .4	18.0 \pm 3	18.9 \pm 1

¹Lipid class. Tot. Lip.: Total lipid. PL: Phospholipids. MGDG: Monogalactosyldiacylglycerides. DGDG: Digalactosyldiacylglycerides.

Individual phospholipid analyses:

The lipid profile for the individual principal phospholipids (PC, PE, PG, PI) in Lemna membranes for control and treated fronds are given in Figures 18a, 18b and 19. PC and PE are the two most abundant phospholipids followed by PG and PI respectively. PC and PE increase with adjuvant treatment whereas PG and PI decrease both in absolute values and as percentages of total phospholipids. Again these changes can be related directly to the change in the number of ethoxyl units in the Triton surfactants. In this case, the lower ethoxylate Tritons or less soluble adjuvants, reduce the concentrations of PG and PI present while the higher ethoxylates (more soluble) tend to stimulate the production of PC and PE.

Fatty acid analyses of lipid classes:

For all experimental sets, the fatty acid content was determined in terms of mole%. These data were compared to that of Grenier et al. [86] for L. minor and reflected similar fatty acid composition.

Table 6 tabulates the fatty acid mole% of total lipids. It was clearly evident that all the adjuvants disturbed the % fatty acid distribution of the total fatty acid content of Lemna. A desaturation occurred in Lemna plant membranes exposed to 40 μ M adjuvant and this accounted for the decrease in the content of palmitic (16:0)¹ and stearic (18:0) acids and a concomitant increase in the amounts of oleic (18:1), linoleic (18:2) and linolenic acids (18:3) (Table 6).

A similar pattern was observed for the fatty acids of the phospholipids. Notable reductions between control and treated fronds were observed for the saturated fatty acid stearic acid. The increase in linoleic acid found in treated fronds possibly accounted for the decrease in stearic and palmitic acids (Table 7).

¹ The first numeral is the number of carbon atoms contained in the fatty acid chain and the second numeral is the number of double bonds in the chain.

TABLE 6: The effect of Triton adjuvant treatment at a concentration of 40 μ M on the fatty acids of the total lipid content of L. minor fronds after 14 days of exposure. Numbers are given as fatty acid mole % of total lipids.

FATTY ACID	-----Treatment-----					
	CONTROL	Dowanol	X-15	X-35	X-114	X-100
¹ 16:0	23.8a	17.5b	18.6b	17.4b	17.3b	18.3b
18:0	1.0a	0.4c	0.5cb	0.6b	0.6b	0.5b
18:1	1.7a	1.7a	3.5b	3.4b	2.9b	2.7b
18:2	16.7a	20.0b	18.8b	19.1b	19.0b	19.1b
18:3	56.8a	59.2a	58.7a	60.0a	60.3a	59.4a

¹16:0 - palmitic acid, 18:0 - stearic acid, 18:1 - oleic acid, 18:2 - linoleic acid, 18:3 - linolenic acid. The letters following the numbers represent a comparison about the means using the Tukey multiple range test. Two means with the same letter are not significantly different at the 0.05 level of significance.

TABLE 7: The effect of Triton adjuvant treatment at a concentration of 40 μ M on the fatty acids of the total phospholipid content of L. minor fronds after 14 days of exposure. Numbers are given as fatty acid mole % of total phospholipids.

FATTY ACID	-----Treatment-----					
	CONTROL	Dowanol	X-15	X-35	X-114	X-100
¹ 16:0	40.5ab	30.5c	42.5a	33.7b	32.4b	38.1ab
18:0	5.3a	1.6c	2.1b	1.5c	1.5c	2.0b
18:1	5.7a	6.9a	7.1a	7.6ab	6.8a	9.4b
18:2	29.2a	35.0a	31.0a	33.8a	34.3a	31.6a
18:3	19.3ab	26.1ab	17.8b	23.9ab	25.0a	19.0ab

¹16:0 - palmitic acid, 18:0 - stearic acid, 18:1 - oleic acid, 18:2 - linoleic acid, 18:3 - linolenic acid. The letters following the numbers represent a comparison about the means using the Tukey multiple range test. Two means with the same letter are not significantly different at the 0.05 level of significance.

The fatty acids of the MGDG show a similar desaturation in treated fronds to that observed in total lipids and phospholipids. It is noted that the levels of linolenic acid (18:3) for control and Dowanol are comparable whereas clearly the Triton treated plants have a greater percentage of this acid (Table 8).

The variation in the fatty acid profile of the DGDG of the treated fronds from control fronds (Table 9) was not as apparent as in the other lipid classes. It is suggested that this class of lipids, of all the classes analyzed, was the least affected by adjuvant treatment when determining the lipid saturation grade.

Tables 10-13 tabulate the fatty acid mole% of the individual principal phospholipids. The fatty acids of the individual phospholipids in the treated groups showed a reduction in the amounts of saturated fatty acid and an increase in the amounts of unsaturated fatty acids. Generally, in all treatment sets, palmitic and stearic acid decreased while oleic, linoleic and linolenic acid increased when these were compared with control sets (Tables 10-13). A differential effect was observed with phosphatidyl ethanolamine, the lower ethoxylates, Tritons X-15 and X-35, invoked a greater desaturation than the higher ethoxylates, Tritons X-100 and X-114 (Table 10).

TABLE 8: The effect of Triton adjuvant treatment at a concentration of 40 μ M on the fatty acids of the monogalactosyl diacylglyceride lipid content of L. minor fronds after 14 days of exposure. Numbers are given as fatty acid mole % of monogalactosyl diacylglyceride.

FATTY ACID	-----Treatment-----					
	CONTROL	Dowanol	X-15	X-35	X-114	X-100
¹ 16:0	19.4a	15.8b	5.1c	4.9c	0.8d	5.1c
18:0	2.7a	0.7b	0.3b	0.3b	0.1b	0.2b
18:1	3.8a	1.7b	0.6b	0.8b	0.2b	0.5b
18:2	5.4a	7.7b	4.3a	4.0a	3.1a	4.6a
18:3	68.7a	74.2a	89.8b	89.9b	95.8b	89.7b

¹16:0 - palmitic acid, 18:0 - stearic acid, 18:1 - oleic acid, 18:2 - linoleic acid, 18:3 - linolenic acid. The letters following the numbers represent a comparison about the means using the Tukey multiple range test. Two means with the same letter are not significantly different at the 0.05 level of significance.

TABLE 9: The effect of Triton adjuvant treatment at a concentration of 40 μ M on the fatty acids of the digalactosyl diacylglyceride lipid content of *L. minor* fronds after 14 days of exposure. Numbers are given as fatty acid mole % of digalactosyl diacylglycerides.

FATTY ACID	-----Treatment-----					
	CONTROL	Dowanol	X-15	X-35	X-114	X-100
¹ 16:0	7.8a	8.0a	5.9a	7.6a	12.5b	4.5a
18:0	1.4ab	2.9a	0.5b	0.7b	0.5b	0.4b
18:1	0.8a	2.8b	1.0ab	1.3ab	1.4ab	0.3a
18:2	6.2ab	12.8a	3.7b	4.9b	6.2ab	4.5b
18:3	84.7a	74.9a	89.2a	85.4a	79.4a	90.3a

¹16:0 - palmitic acid, 18:0 - stearic acid, 18:1 - oleic acid, 18:2 - linoleic acid, 18:3 - linolenic acid. The letters following the numbers represent a comparison about the means using the Tukey multiple range test. Two means with the same letter are not significantly different at the 0.05 level of significance.

TABLE 10: The effect of Triton adjuvant treatment at a concentration of 40 μ M on the fatty acids of the phosphatidyl ethanolamine lipid content of L. minor fronds after 14 days of exposure. Numbers are given as fatty acid mole % of phosphatidyl ethanolamine.

FATTY ACID	-----Treatment-----					
	CONTROL	Dowanol	X-15	X-35	X-114	X-100
¹ 16:0	46.5a	42.6a	27.9c	26.2c	44.1a	35.5b
18:0	6.4a	2.7b	2.7b	2.7b	1.3bc	0.6c
18:1	4.8a	7.1ab	10.0c	7.8ab	5.3a	3.9a
18:2	24.7a	22.0a	30.0b	35.5b	28.9b	32.4bc
18:3	17.6a	25.6b	29.7c	27.6c	20.4ab	27.8c

¹16:0 - palmitic acid, 18:0 - stearic acid, 18:1 - oleic acid, 18:2 - linoleic acid, 18:3 - linolenic acid. The letters following the numbers represent a comparison about the means using the Tukey multiple range test. Two means with the same letter are not significantly different at the 0.05 level of significance.

TABLE 11: The effect of Triton adjuvant treatment at a concentration of 40 μ M on the fatty acids of the phosphatidyl inositol lipid content of L. minor fronds after 14 days of exposure. Numbers are given as fatty acid mole % of phosphatidyl inositol.

FATTY ACID	-----Treatment-----					
	CONTROL	Dowanol	X-15	X-35	X-114	X-100
¹ 16:0	59.6a	52.8a	29.7c	44.1b	38.6b	31.8c
18:0	8.1a	1.1c	1.2c	2.0c	5.2b	2.3c
18:1	4.7a	3.4a	1.8c	4.4a	6.6a	7.9b
18:2	18.4a	26.2b	27.5b	20.8a	28.5b	29.9b
18:3	9.3a	16.6b	39.7e	28.7d	21.0c	27.8d

¹16:0 - palmitic acid, 18:0 - stearic acid, 18:1 - oleic acid, 18:2 - linoleic acid, 18:3 - linolenic acid. The letters following the numbers represent a comparison about the means using the Tukey multiple range test. Two means with the same letter are not significantly different at the 0.05 level of significance.

TABLE 12: The effect of Triton adjuvant treatment at a concentration of 40 μ M on the fatty acids of the phosphatidyl choline lipid content of L. minor fronds after 14 days of exposure. Numbers are given as fatty acid mole % of phosphatidyl choline.

FATTY ACID	-----Treatment-----					
	CONTROL	Dowanol	X-15	X-35	X-114	X-100
¹ 16:0	48.0a	65.5c	18.7b	22.2b	23.1b	20.9b
18:0	5.8a	3.1b	1.1c	1.1c	1.7c	0.8c
18:1	5.1a	4.3a	3.4a	3.1a	4.2a	3.7a
18:2	26.3a	16.0b	37.5c	35.0c	21.3a	33.1c
18:3	19.6a	23.3a	21.8a	17.3a	26.5b	23.9a

¹16:0 - palmitic acid, 18:0 - stearic acid, 18:1 - oleic acid, 18:2 - linoleic acid, 18:3 - linolenic acid. The letters following the numbers represent a comparison about the means using the Tukey multiple range test. Two means with the same letter are not significantly different at the 0.05 level of significance.

TABLE 13: The effect of Triton adjuvant treatment at a concentration of 40 μ M on the fatty acids of the phosphatidyl glycerol lipid content of *L. minor* fronds after 14 days of exposure. Numbers are given as fatty acid mole % of phosphatidyl glycerol.

FATTY ACID	-----Treatment-----					
	CONTROL	Dowanol	X-15	X-35	X-114	X-100
¹ 16:0	45.5a	41.0a	30.3b	34.9b	31.1b	27.1b
18:0	8.5a	9.9a	3.9c	6.0b	8.1ab	8.2ab
18:1	4.2a	9.8b	6.5a	6.7a	13.1b	7.7ab
18:2	22.1a	16.0c	37.5d	35.0d	21.3a	33.1d
18:3	19.6a	23.3ab	21.8a	17.3a	26.5b	23.9ab

¹16:0 - palmitic acid, 18:0 - stearic acid, 18:1 - oleic acid, 18:2 - linoleic acid, 18:3 - linolenic acid. The letters following the numbers represent a comparison about the means using the Tukey multiple range test. Two means with the same letter are not significantly different at the 0.05 level of significance.

Anisotropy:

The microviscosity¹ of chloroplast membranes isolated from Lemna fronds which had been treated with 100 μM Triton for a two week period is shown in Figure 20 (these fronds are referred to as "previously treated"). Also shown, is the microviscosity of chloroplast membranes whose isolation medium was treated with 100 μM Triton (not previously treated). In the previously treated fronds, the lower ethoxylate Tritons (X-15 and X-35) showed a significant decrease in membrane microviscosity. Thus, apart from Dowanol, a differential effect towards the individual Tritons was apparent. In fronds treated following chloroplast isolation (ie. not previously treated, Figure 20), however, the decrease in membrane microviscosity for all treatments was four to five times greater than control levels. It is noted that the standard deviation shown are the deviations from the combination of three separate experiments (Figure 20).

¹⁴C Triton incorporation:

Results for the incorporation of ¹⁴C X-15 and X-100 after a two week treatment period are given in Figure 21. The bioconcentration factor (BCF) for X-35 and X-100 were found to be 156 and 39,

¹Microviscosity was measured as the degree of diphenylhexatriene (DPH) polarization (p), a measurement dependent on parallel and perpendicular emission polarizer intensities, where: $p = (I_{\text{par}} - I_{\text{per}}) / (I_{\text{par}} + I_{\text{per}})$ [109].

respectively. X-35 accumulates in all Lemna tissues a factor of 4 times greater than X-100. Following a two week treatment period, membrane lipid to adjuvant ratio in chloroplasts were calculated at 100:4 for X-35 and 100:2 for X-100. Accumulation of both X-100 and X-35 was found in the tissues of Lemna in the following order of increasing incorporation: Chloroplast < cytoplasm and organelles < cellular debris.

FIGURE 6. Chlorophyll content as % control in Lemna minor plants exposed to $965 \mu\text{g ml}^{-1}$ Dowanol, $n = 3$ replicates, standard deviations shown. (100% = 6.1 mg Chl/g dw)

AGGREGATE GENERATIONS
Chl/g dw as % control

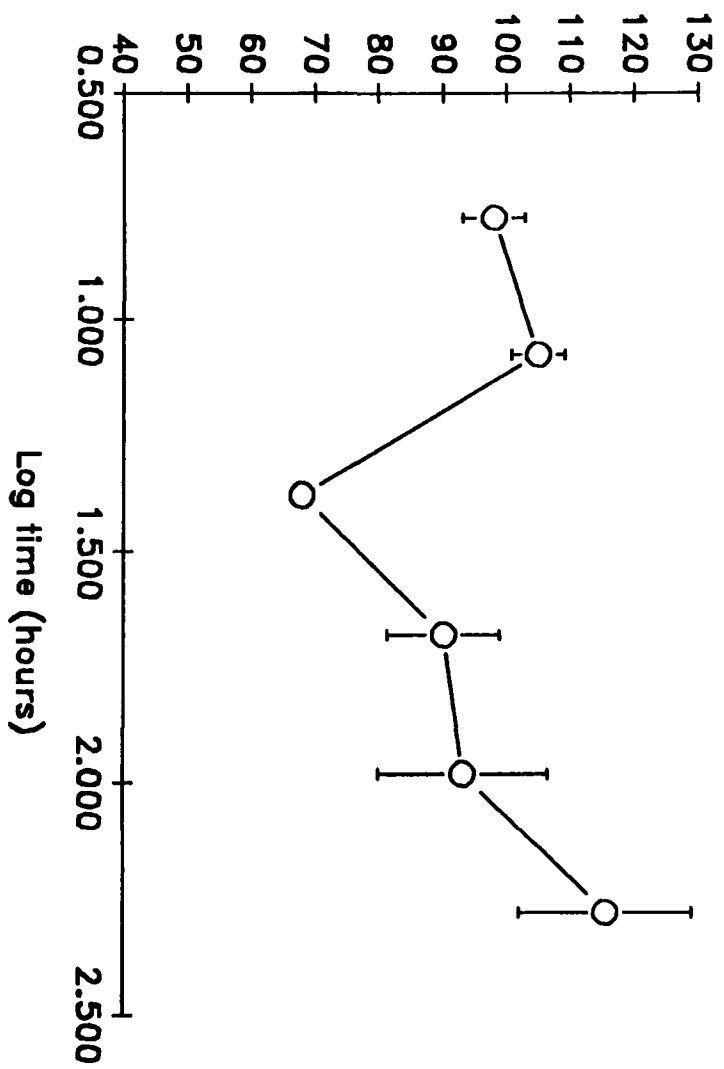

FIGURE 7. The effect of $965 \mu\text{g ml}^{-1}$ Dowanol on aggregate generations of Lemna minor (P - T) transient photosynthetic effects as % control, n = 4 replicates, standard deviations shown, 8th order regression, $r = 0.95$, (100% = 24.4).

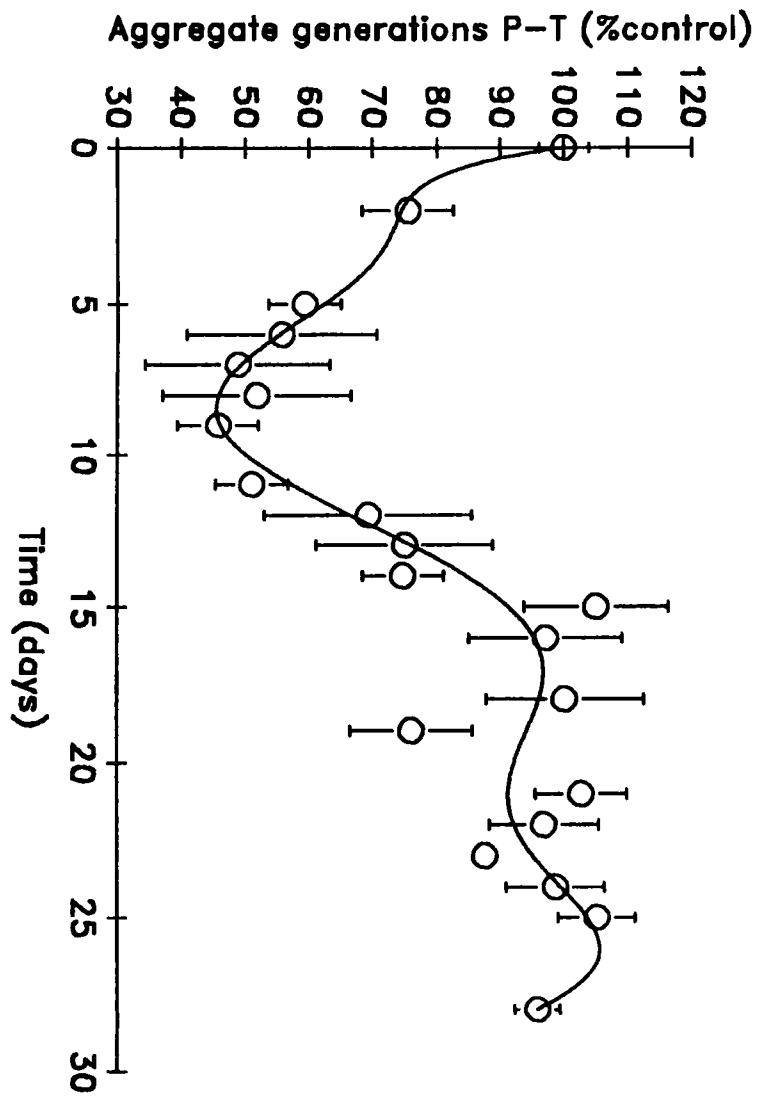

FIGURE 8. Leakage of K^+ into the bathing media by Lemna minor plants exposed to $965 \mu\text{g ml}^{-1}$ Dowanol, $n = 3$ replicates, 95% confidence intervals shown.

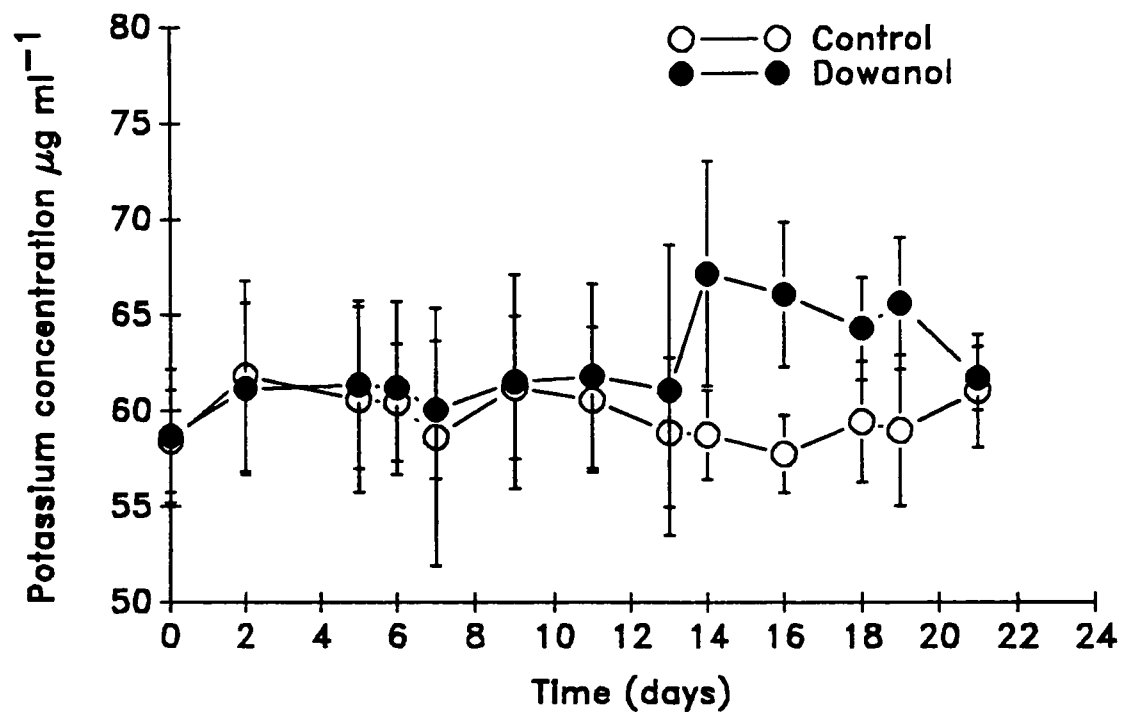

FIGURE 9. Leakage of Mg^{2+} into the bathing media by Lemna
minor plants exposed to $965 \mu g \text{ ml}^{-1}$ Dowanol, $n = 3$
replicates.

No significant difference observed.

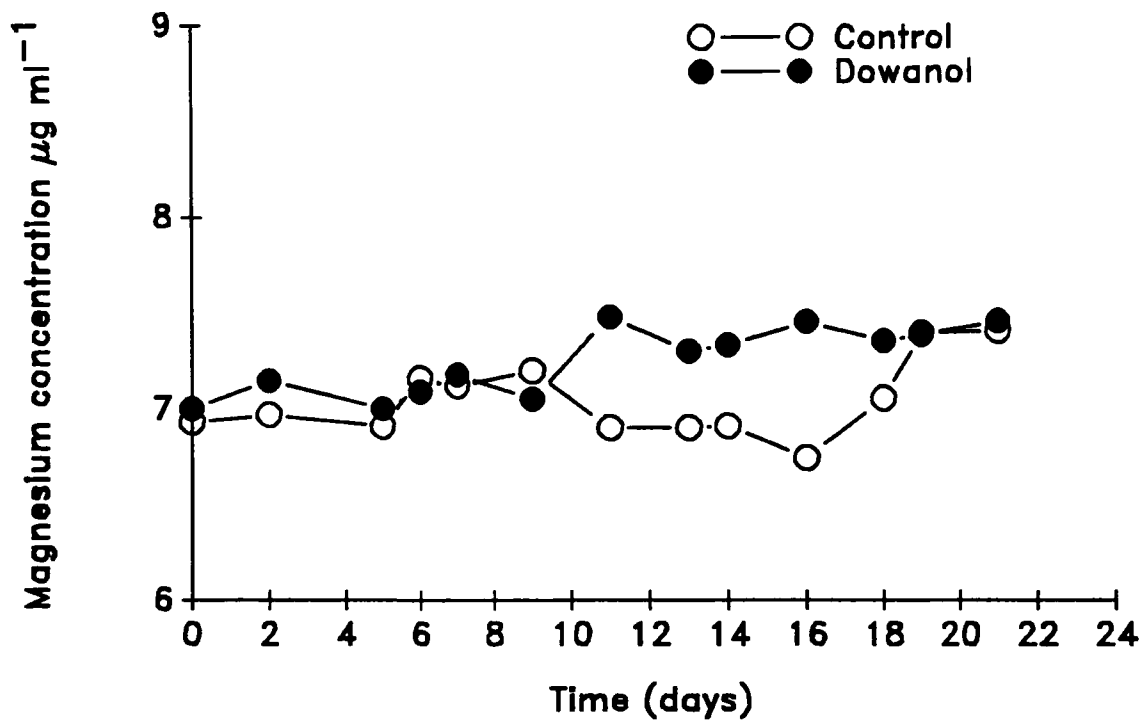

FIGURE 10. ATP content as % control in Lemna minor plants exposed to $965 \mu\text{g ml}^{-1}$ Dowanol, $n = 3$ replicates, standard deviations shown. (100% = $468 \mu\text{g/g dw}$)

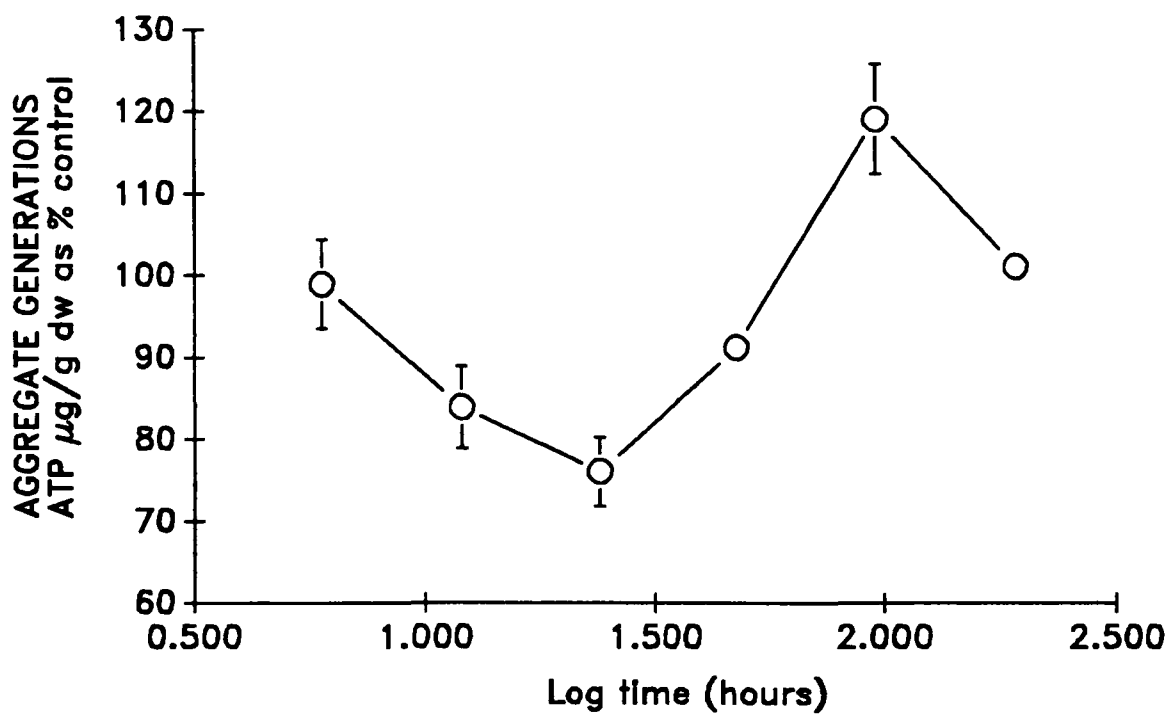

FIGURE 11. The effect of $965 \mu\text{g ml}^{-1}$ Dowanol on aggregate generations of Lemna minor. (P - T) transient photosynthetic effects as % control, following depuration, n = 3 replicates, standard deviations shown, 5th order regression, r = 0.96, (100% = 24.4).

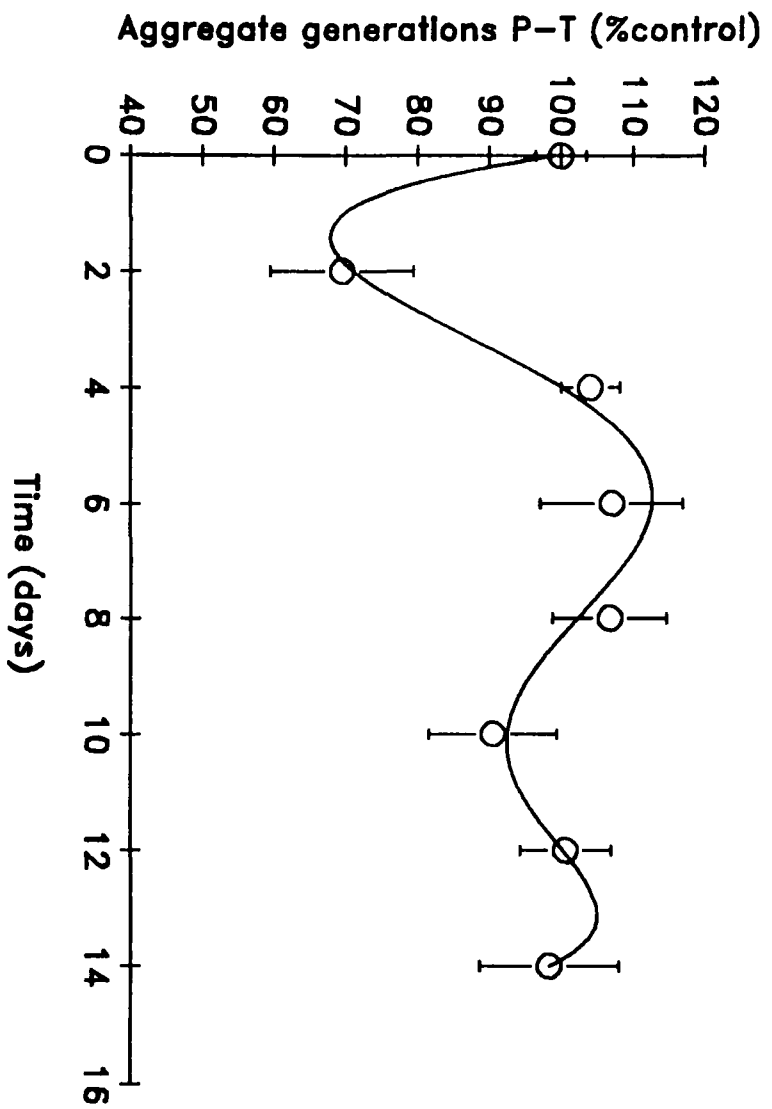

FIGURE 12. The effects of $965 \mu\text{g ml}^{-1}$ Dowanol on aggregate generations accumulation by Lemna minor plants, $n = 3$ replicates, standard deviations shown, 6th order regression, $r = 0.91$.

AGGREGATE GENERATIONS ACCUMULATION
OF DOWANOL/10 FRONDS ($\mu\text{g}/10$ fronds)

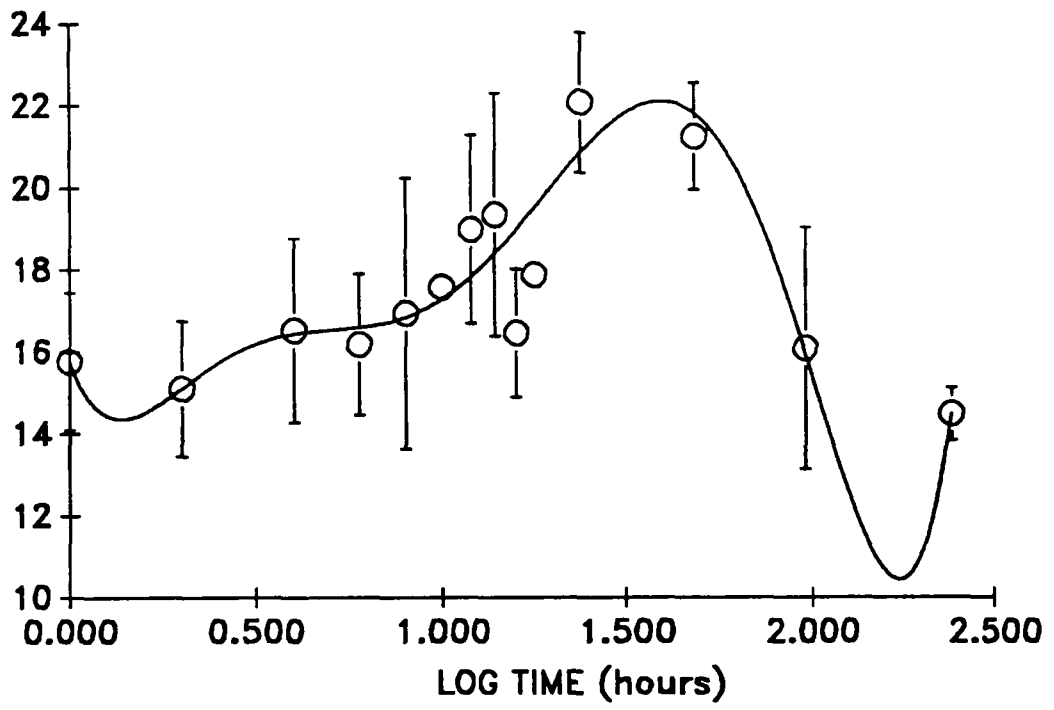

FIGURE 13. L. minor frond number, % control vs adjuvant log concentration in $\mu\text{g ml}^{-1}$, 14 days after treatment, n = 4 replicates, standard deviations shown. (100% = 422)

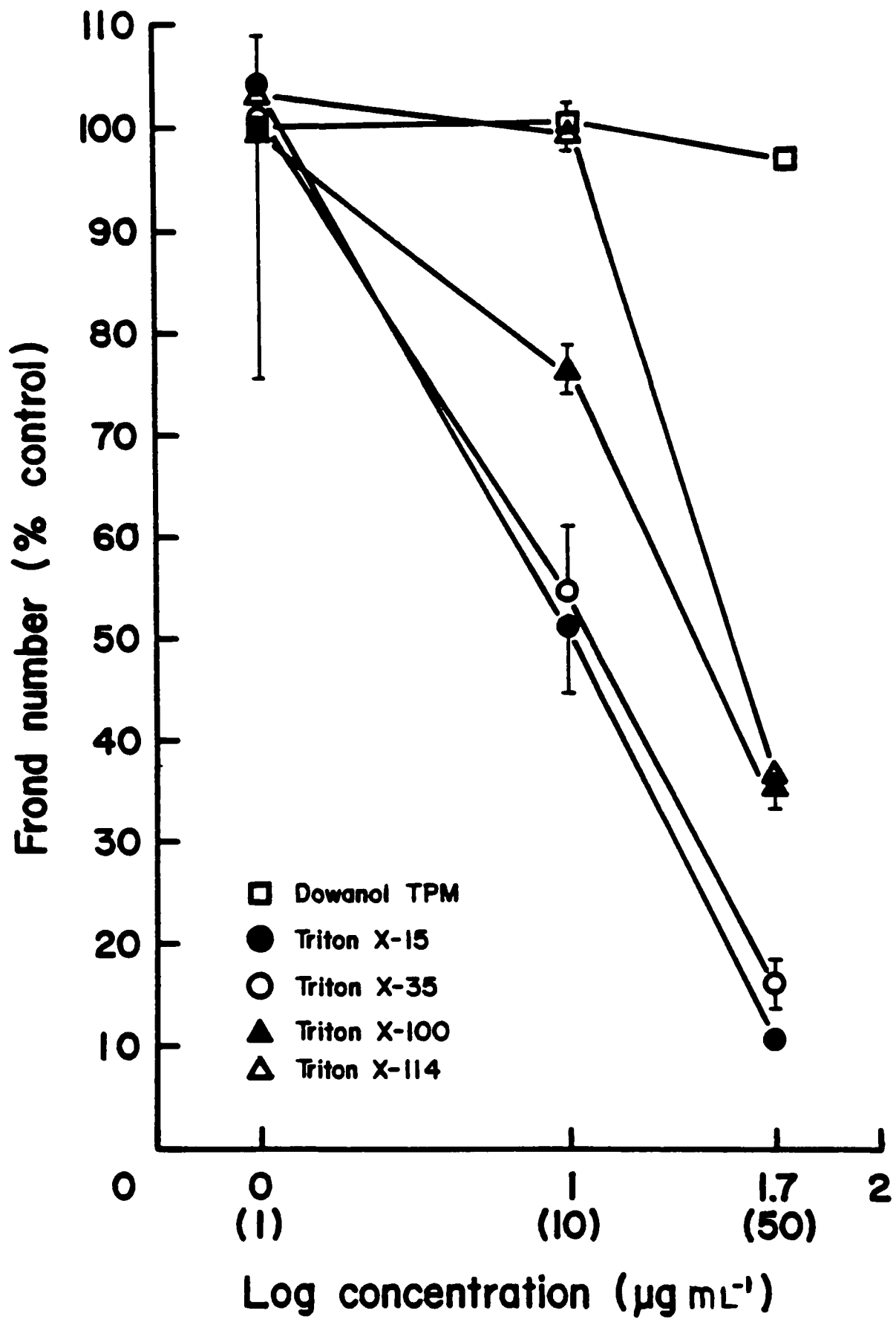

FIGURE 14 A). Graph of phytotoxicity parameter as % control vs the hydrophilic lipophilic balance of the Triton adjuvants. Phytotoxicity at $10 \mu\text{g ml}^{-1}$ of the Triton series towards L. minor 14 days after treatment, $n = 4$ replicates, standard deviations shown. (100% = 6.1 mg chl/g dw, 1.19 mg/10 frond, 422 and 24.4 for chlorophyll content, dry weight, frond number and fluorescence, respectively)

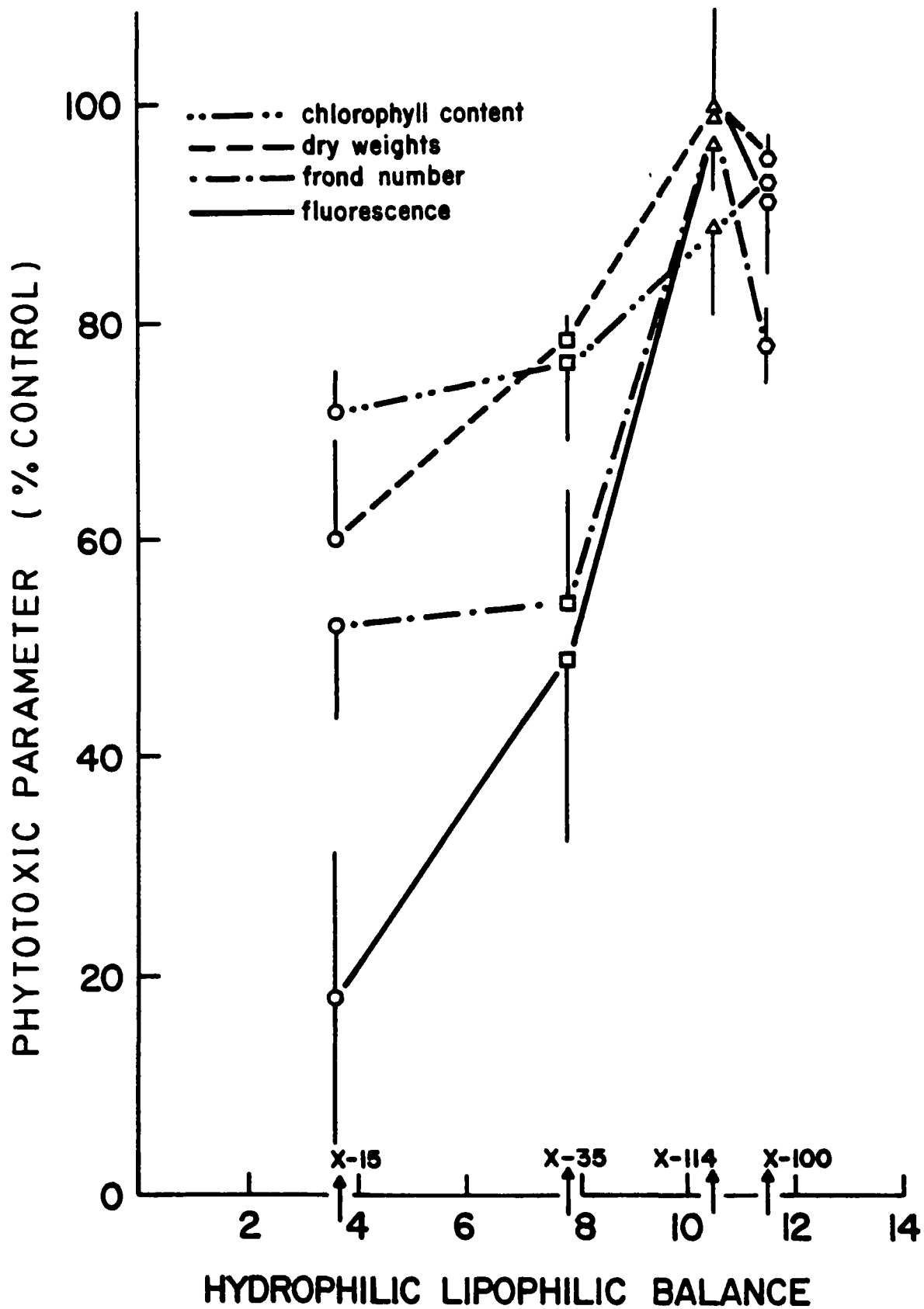

FIGURE 14 B). Graph of conductivity as % control vs the hydrophilic lipophilic balance of the Triton aduvants. Phytotoxicity at $10 \mu\text{g ml}^{-1}$ of the Triton series towards L. minor 14 days after treatment, n = 4 replicates, standard deviations shown. (100% = $3.58 \mu\text{siemens}/10$ fronds)

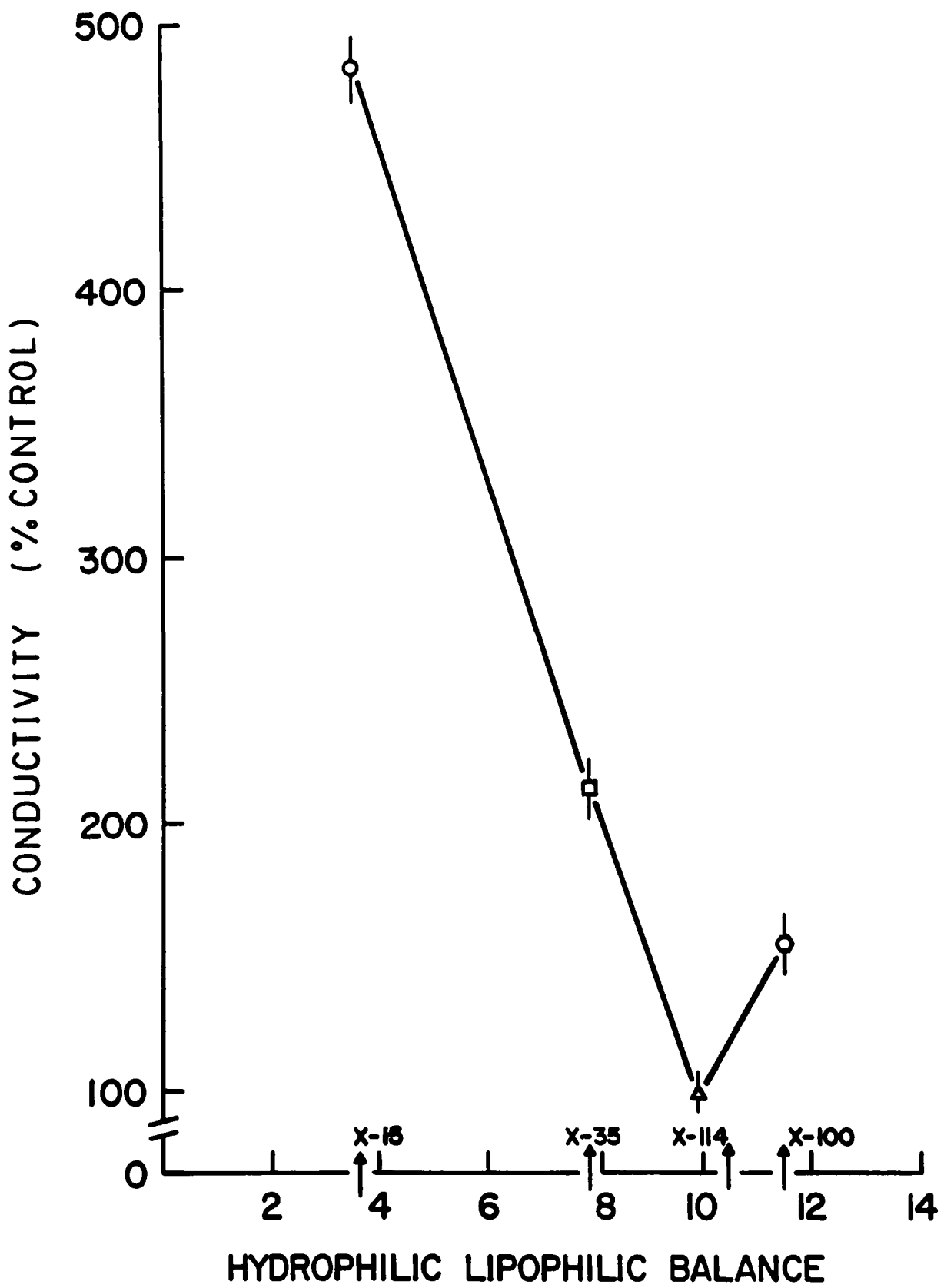
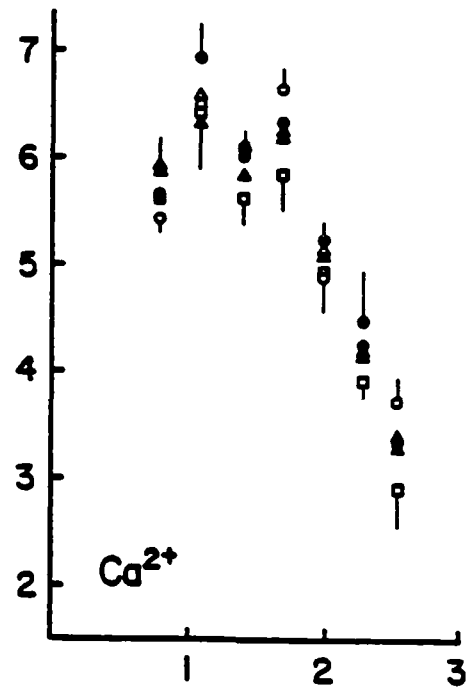
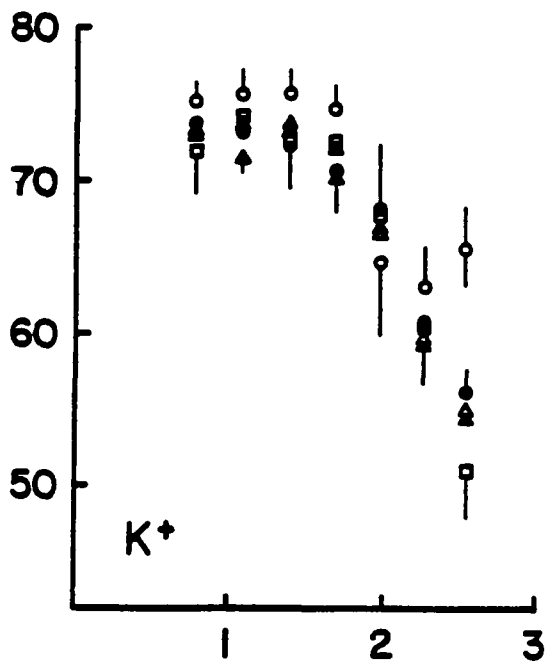
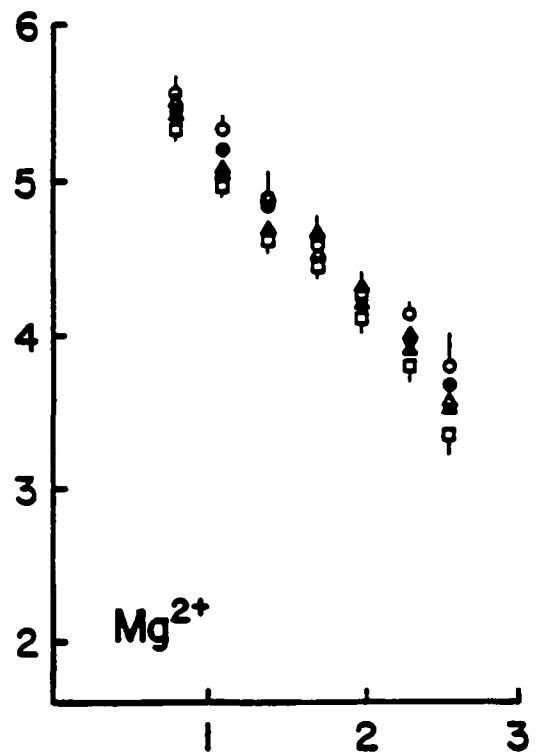
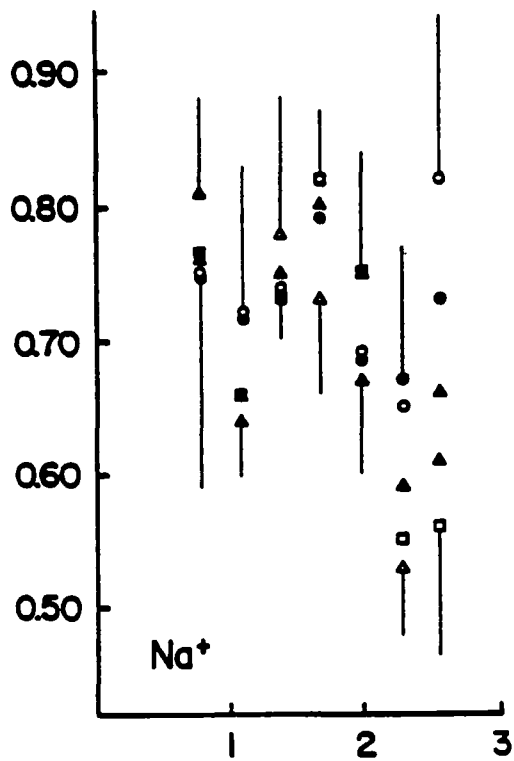

FIGURE 15. Leakage of Na^+ , Ca^{2+} , K^+ and Mg^{2+} into the bathing media from L. minor plants exposed to $10 \mu\text{g ml}^{-1}$ of the Triton series. \square - controls, \blacktriangle - Triton X-114, \blacktriangle - Triton X-100, \bullet - Triton X-35, \circ - Triton X-15, $n = 4$ replicates, some standard deviations shown.

ELECTROLYTE CONCENTRATION $\mu\text{g/ml}$



LOG TIME (hrs)

FIGURE 16. Effects of adjuvants ($10 \mu\text{g ml}^{-1}$) of the fenitrothion formulation on L. minor. $Y = 99 - 9.6X$, $r^2 = 0.75$, $n = 4$ replicates, standard deviations shown. (100% = 422)

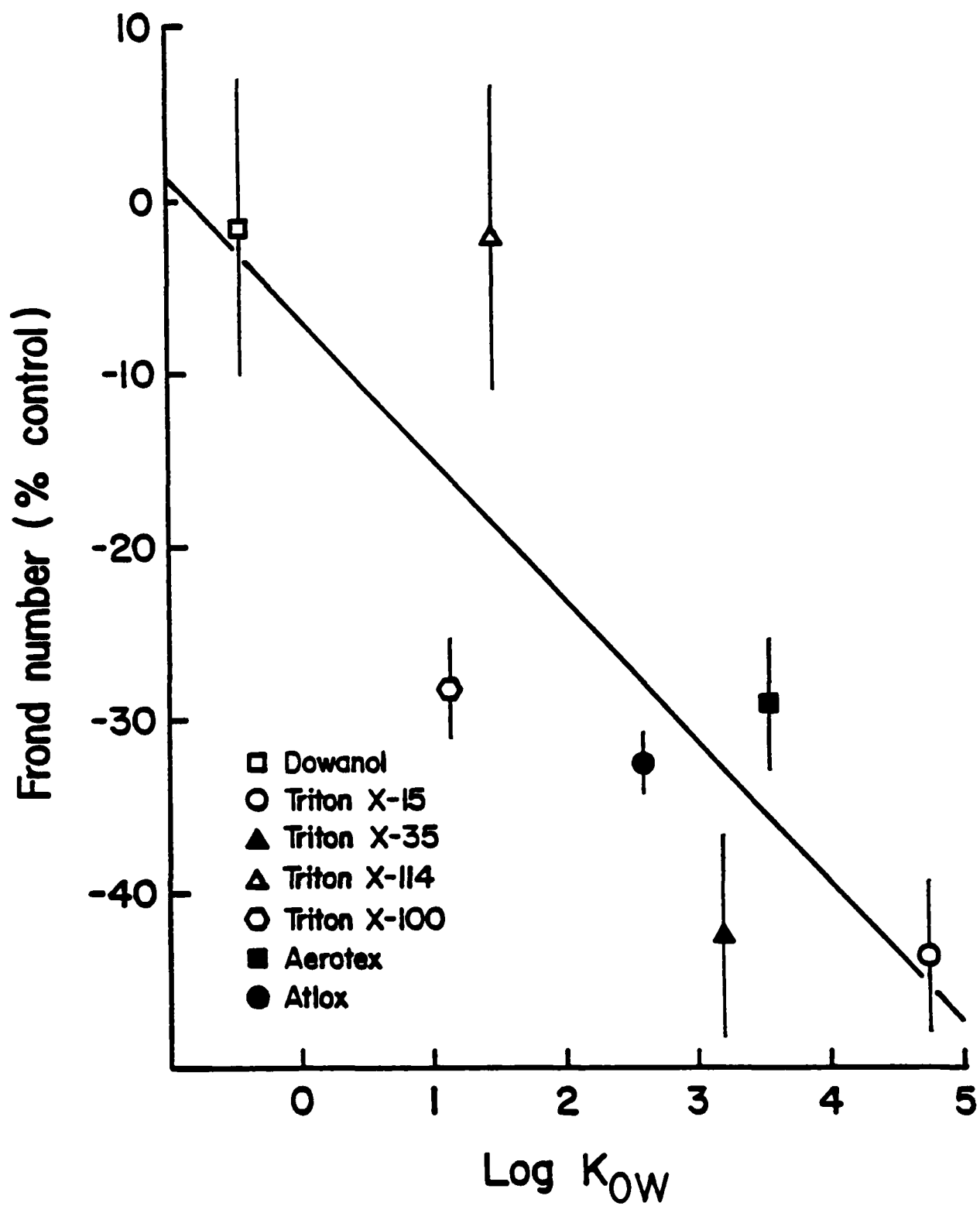

FIGURE 17 a). Lipid class concentration and total lipid concentration in $\mu\text{g/g dw}$ vs treatment, 14 days after treatment, n = 3 replicates, standard deviations shown.

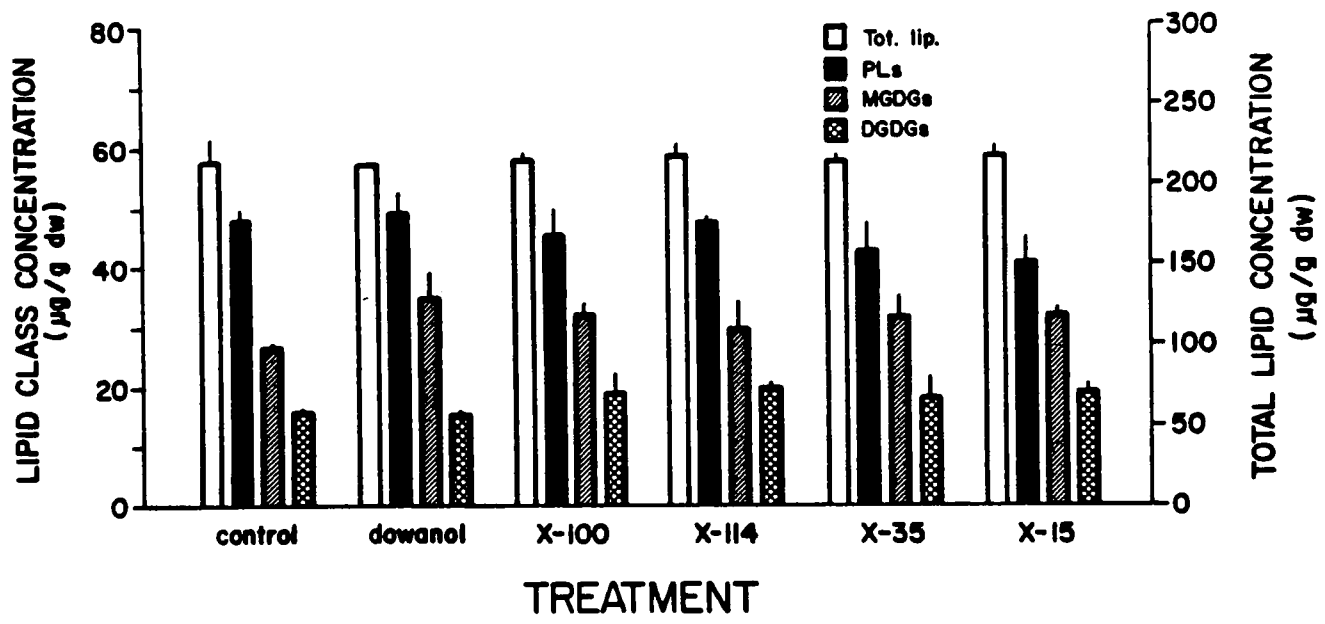

FIGURE 17 b). Lipid class concentration and total lipid concentration in $\mu\text{g/g dw}$ vs treatment as % control, 14 days after treatment, n = 3 replicates, standard deviations shown.

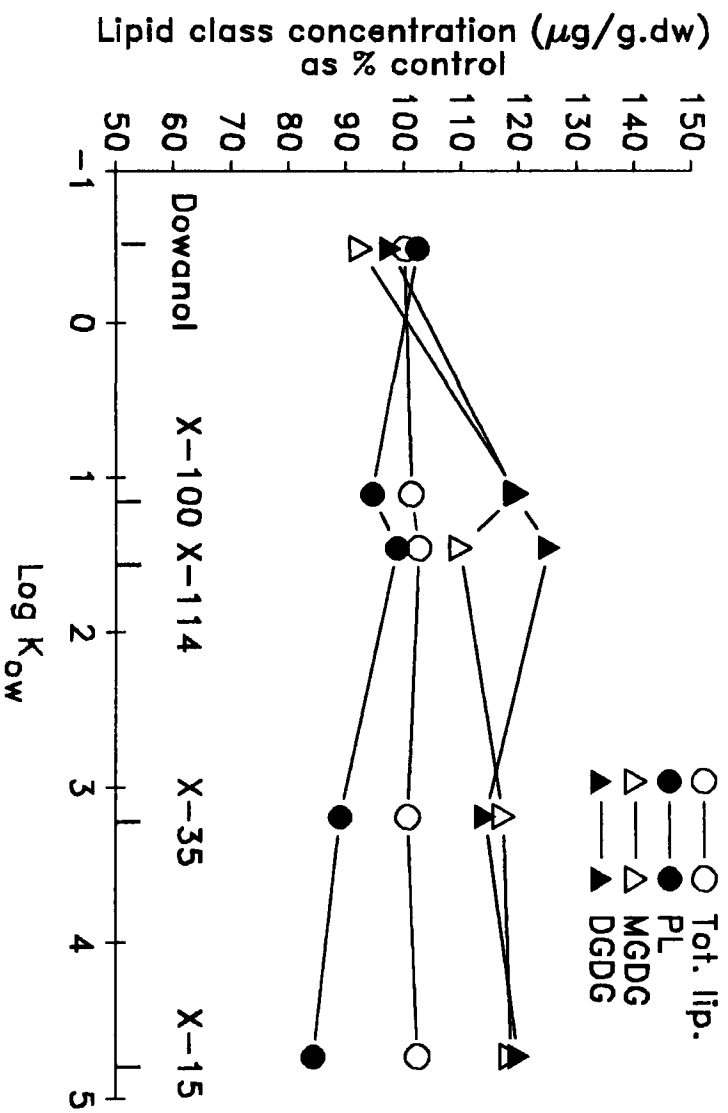

FIGURE 18 a). Individual phospholipid concentration in $\mu\text{g/g}$ dw vs treatment, 14 days after treatment, n = 3 replicates, standard deviations shown.

PC - Phosphatidyl choline. PE - Phosphatidyl ethanolamine. PG
- Phosphatidyl glycerol. PI - Phosphatidyl inositol.

FIGURE 18 b). Individual phospholipid concentration in $\mu\text{g/g}$ dw vs treatment as % control, 14 days after treatment, n = 3 replicates, standard deviations shown.

PC - Phosphatidyl choline. PE - Phosphatidyl ethanolamine. PG
- Phosphatidyl glycerol. PI - Phosphatidyl inositol.

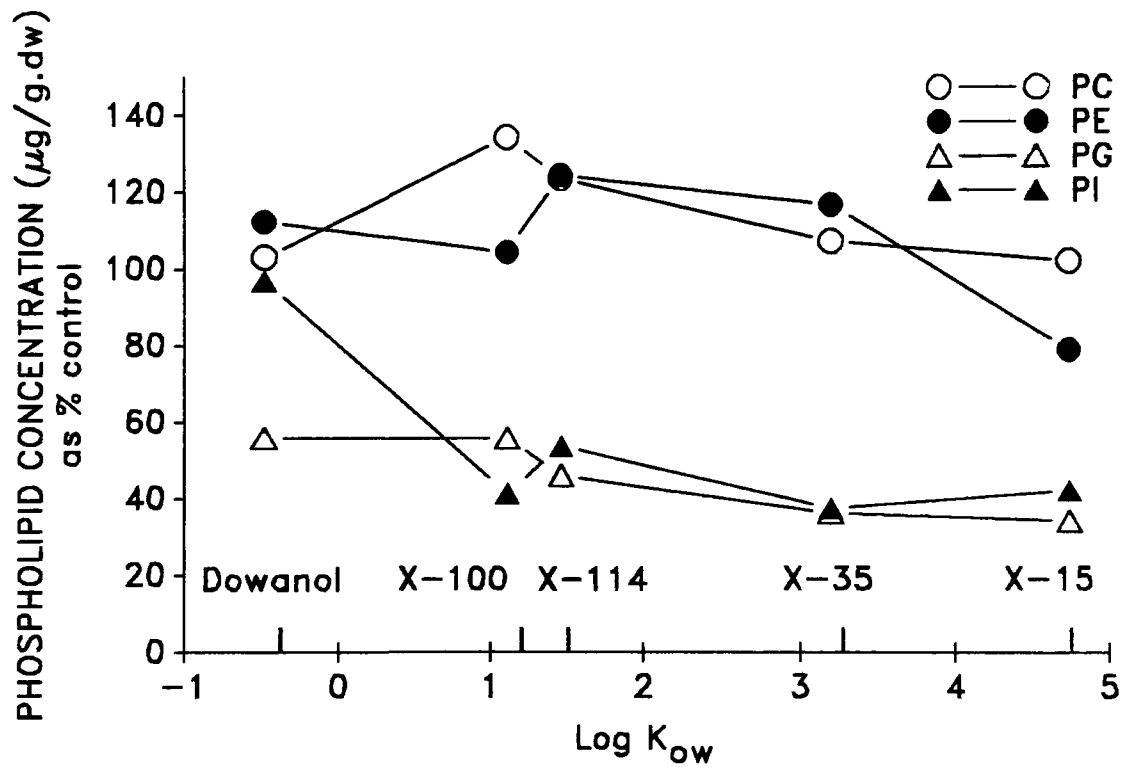

FIGURE 19. Individual phospholipid concentration as % total vs treatment, 14 days after treatment, n = 3 replicates, standard deviations shown.

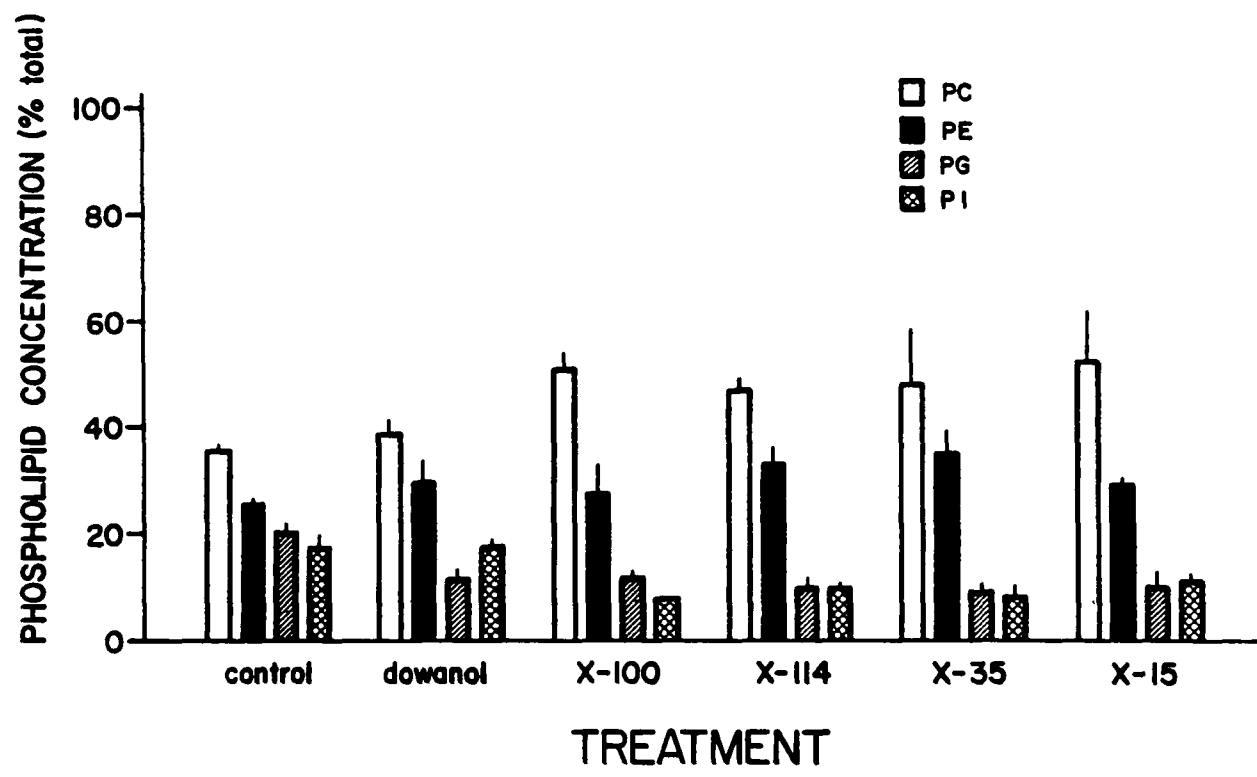

FIGURE 20. Anisotropy vs treatment, 14 days after treatment for previously treated and not previously treated fronds, n = 3 replicate experiments, standard deviations shown.

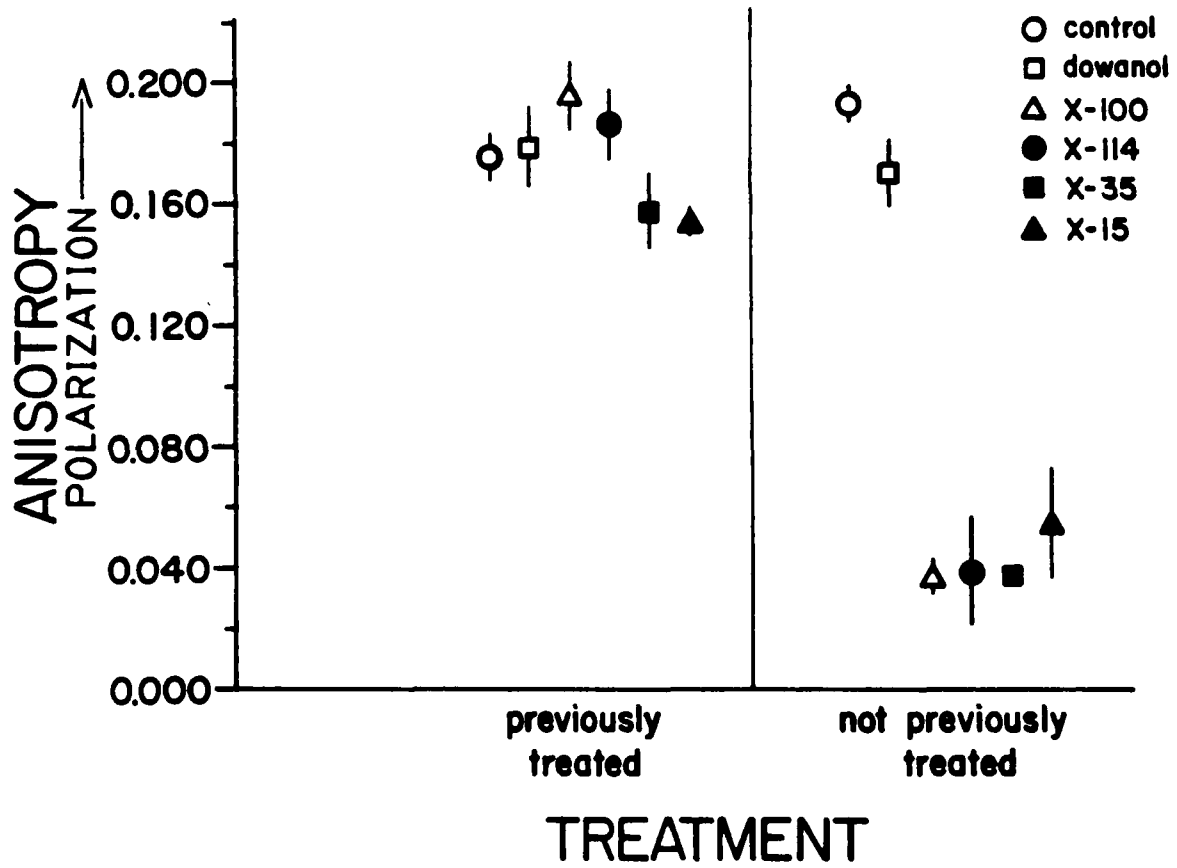
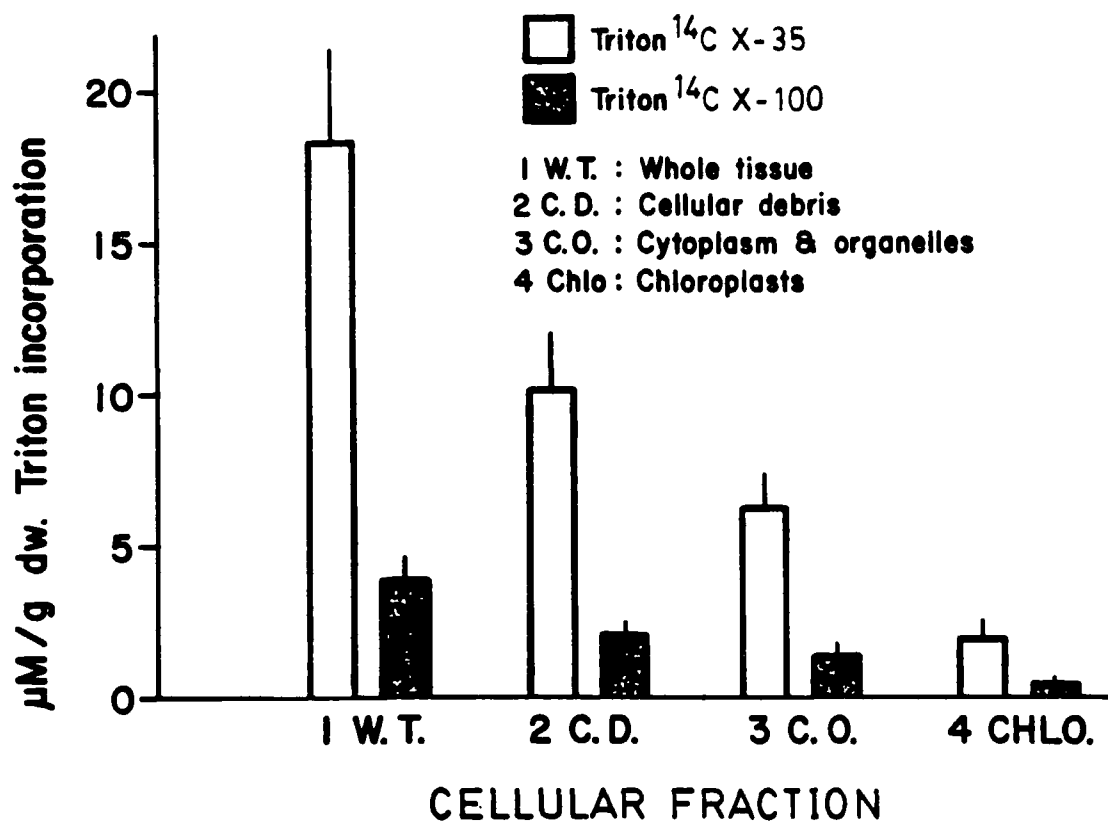

FIGURE 21. ^{14}C X-35 and ^{14}C X-100 uptake in $\mu\text{M/g dw}$ vs cellular fraction, after 14 days, n = 3 replicates, standard deviations shown.



CHAPTER IV

DISCUSSION

DOWANOL EXPERIMENTS

No previous studies to monitor toxicity using clonal cultures of physiologically comparable colony types of a higher plant have been reported. The use of R-3 fronds reduced inherent variability in metabolic reactivity to stress. In this study, significant metabolic perturbation of Lemna minor by Dowanol was only observed at the highest concentration used, $965 \mu\text{g ml}^{-1}$, which is at the level of toxicity suggested by Federal Canadian guidelines for product registration [46]. These studies are in agreement with earlier studies by Weinberger and Greenhalgh [44], who found Dowanol at concentrations below $100 \mu\text{g ml}^{-1}$ had no effect on any of the physiological functions monitored in Chlamydomonas reinhardtii and Chlorella pyrenoidosa.

The first study to explicitly describe the sequence of frond emergence and the intervals required for daughter colony separation in Lemna was performed by Datko et al. [13], where the sequence was determined for Lemna paucicostata Hegelm. (strain 6746). They showed that a Lemna population increases with an exponential growth phase to attain an equilibrium distribution of colony types a few generations after inoculation. This distribution was independent of the initial frond proportion and

in their study was reported to have 79% of the colonies in the left hemicycle and 21% in the right. Results of the present study indicate an analogous growth pattern for this particular clone of Lemna minor L., with a reversed distribution of colony types, namely 67% of the total distribution in the right hemicycle and 33% in the left; notwithstanding that, the vegetative growth cycle is divided into the same stages as those described by Datko et al. [13] and that other clones may show different distributions.

Photosynthetic activity, directly correlated with electron flow at photosystem 2 (PS 2), was measured by the fluorescence emitted from the leaf and is related to the difference between P and T transients [114,105] (Appendix F). Following exposure to 965 $\mu\text{g ml}^{-1}$ Dowanol it was observed that perturbant effects were carried over several daughter generations, namely, a right handed D1M3 or first daughter of a fourth mother as the first mother is always designated as M0. The observed effects on the daughter generations, as contrasted with the mother generations, indicates that the photosynthetic dysfunction evoked by 965 $\mu\text{g ml}^{-1}$ Dowanol was transmittable down the generations. The use of a fluorometer [44] has proven to be a rapid and efficient method to assess the relative toxicity of environmental pollutants. It is known that herbicides which inhibit photosynthesis increase chlorophyll fluorescence due to the dissipation of adsorbed radiant energy in the absence of useful photochemistry [115]. The transient changes in the fluorescence following the onset of illumination of dark-

adapted tissue are representative of the total fluorescence values obtained with the fluorometer [114,116,117,118]. Fluorescence induction changes are associated with damage to the water splitting enzyme system at PS 2. This is hypothesized to lead to the reduction of the level of efficiency of the primary electron acceptor Q which in turn effectively inhibits electron transport between PS 2 and PS 1. Lack of utilization of the electron flow leads to the destruction of chlorophyll [114]. Surfactants tend to cause mild to severe water soaking which is often followed by a decline in fluorescence [116]. Moody *et al.* [105] found similar decreases in fluorescence with algae treated with the surfactants Aerotex and Nonylphenol which are constituents of some of the fenitrothion and Matacil pesticide formulations. The ICF₁₀₀ value for Dowanol (the lowest concentration of a test compound required to totally suppress the fluorometer response) has been estimated to be over 10,000 $\mu\text{g ml}^{-1}$ [119].

It is likely that the hydrophilic Dowanol molecules, without an apparent effect on ion fluxes, may reach the photosynthetic site of the thylakoid membranes and to perhaps obstruct the Hill reaction, thereby reducing photosynthetic activity. The active site of the molecule, the hydroxyl group, may have an active role perturbing membrane lipid/protein complexes. This would invoke an inefficient system and a consequent decrease in photosynthetic activity and overall metabolism, as presently indicated by effects on biomass growth, chlorophyll, and ATP content.

The photosynthetic pigments of the photosynthetic apparatus were also affected following exposure to $965 \mu\text{g ml}^{-1}$ Dowanol (the highest concentration tested) (Figure 6). It is noteworthy that this perturbation was followed by an overshooting effect 10 days after treatment. Overcompensation is a phenomenon often observed in organisms subject to stressors [120,121]. Phytotoxicity via chlorophyll bleaching has recently been well documented [122] and may be due to a peroxidation of membrane bound polyunsaturated fatty acids together with a breakdown of carotenes and chlorophylls, leading to reduced electron transport. Because of its high water solubility, Dowanol possibly preferentially perturbs the redox-water splitting reaction of photosynthesis at PS 2, rather than uniquely denaturing the membrane pigment complexes.

Total plant vigour as reflected by total plant ATP, was also negatively affected by exposure to high treatment levels of Dowanol. Weinberger and Greenhalgh [123] reported similar depressions (20%) in ATP production in tree seeds subjected to Aerotex, Nonylphenol and Matacil 1.8D. Iyengar [124] reported a 75% decrease in ATP content when Lemna minor plants were exposed to $6.25 \mu\text{g ml}^{-1}$ Nonylphenol and Matacil 1.8D 24 h after treatment. He suggested that a reduction in ATP may have caused an inhibition of photosynthesis, since ATP is needed to operate the Calvin cycle. In the present studies, reduced ATP (and as previously

noted, reduced total chlorophyll) was subsequently followed by an overcompensation effect 8 days after treatment, again indicative of stressor response [120,121]. Dowanol displayed short term effects on Lemna which were followed by subsequent recovery. No acute or chronic effects were observed on photosynthetic fluorescence ATP or chlorophyll content. The concentration of Dowanol was followed in the media with time and no significant change was observed, hence further supporting the notion that acclimation had occurred. Subbaraj and Bose [125] observed a recovery from methyl parathion-induced damage of the photosynthetic apparatus in Chlorella protothecoides and suggested that this depended on thylakoid membrane repair. Further, they stated that recovery from the insecticide-induced damage of the photosynthetic apparatus is a general characteristic of photosynthetic organisms.

Leakage of electrolytes from plants as measured by changes in electrical conductance is an indication of membrane permeability integrity, but does not give an indication of specific ion leakage. Perturbance in the levels of specific ions are indicative of tertiary effects on membrane integrity. The effects reported in this study, observed two weeks after treatment with $965 \mu\text{g ml}^{-1}$ Dowanol, were possibly a direct consequence of photosynthetic inhibition.

Surfactant exposure has caused electrolyte imbalance in a number of organisms [50,61,126]. The ion leakage results obtained in the present study are comparable to those of Weinberger and Greenhalgh [123] who found that Mg^{2+} ion leakage was negligibly affected by exposure to a range of surfactants whereas changes in the leakage of K^+ ion were indicative of cellular perturbation [44]. A positive correlation between solubility and ion leakage induction was found by Hutchinson *et al.* [60] and this is supported by the present study.

Maximum adjuvant accumulation was concurrent with a decrease in chlorophyll and ATP contents. The $\log K_{ow}$ for the Dowanol used in this study was -0.5. Values of $\log K_{ow}$ greater than 4.5 indicate a considerable potential uptake of the chemical by aquatic fauna [37]. Because of the high water solubility of Dowanol, bioaccumulation into organisms is unexpected as the water solubility of organic compounds was found to be inversely correlated with bioaccumulation [35,127,128].

In summary, Dowanol at a concentration of $965 \mu g \text{ ml}^{-1}$ has an effect on chlorophyll and ATP contents, on photosynthetic activity and on the leakage of electrolytes in Lemna. This effect, however, did not persist as the plants recovered within a two week period. This study indicates that exposure of sensitive nontarget phytobiota to field relevant concentration of Dowanol ($1 \mu g \text{ ml}^{-1}$) should not be biotoxic and that Dowanol used under registration

guidelines can be considered to be one of the few environmentally safe adjuvants. A concentration of 22 $\mu\text{g}/10$ fronds may be indicative of the toxic threshold level that would have to be accumulated by Lemna in order for phytotoxic symptoms to be induced.

TRITON EXPERIMENTS

Structure activity relationships:

1) Physico-chemical properties:

A positive correlation was found for the degree of phytotoxicity and the hydrophilic lipophilic balance (HLB) and octanol water partition coefficients (K_{OW}) of the Triton surfactants.

A) HLB:

Triton X-114 is categorized among the higher ethoxylates thus the compound is more water soluble and less toxic than the lower ethoxylates (X-15 and X-35) as was observed in the present study. Triton X-114 contains a branched octyl alkyl moiety and 7-8 ethoxyl units, giving it an HLB of 12.4. Nonylphenol containing a nonyl alkyl moiety (a mixture of branched chain isomers) along with 11 ethoxyl units, giving it an HLB of 13.8, has been shown by

Iyengar [124] to have deleterious effects on Lemna minor, at field relevant concentrations ($4.5 \mu\text{g ml}^{-1}$). This latter surfactant was also shown to perturb the population dynamics of the alga Chlorella pyrenoidosa and distort the flagellae and the ultrastructural architecture of the cells of Chlamydomonas reinhardii at $0.5-0.7 \mu\text{g ml}^{-1}$ [129]. With regard to the HLB, one would expect nonylphenol to be less toxic than X-114. This not being the case, the determinant of toxicity may be the length and composition of the alkyl moiety. Phytotoxicological studies [50,75,130,131], in which the aliphatic chain length of nonionic compounds is varied, however, have proven to be contradictory [6,132] and any correlations found from the results of these studies are species attributed [133].

O'Sullivan et al. [134] found the surfactants, Tween 20, Triton X-77 and X-100 enhanced the effectiveness of low glyphosate rates on rape, wheat oats and barley, whereas Triton X-114 and several other surfactants reduced the glyphosate effectiveness. The mechanism for the enhancement or reduction of glyphosate phytotoxicity is still unknown but the authors suggested that surfactants affect the penetration or retention of glyphosate. In the present study, Triton X-100 an octyl phenoxy with 9-10 ethoxyl units and an HLB of 13.5, proved to be more phytotoxic at $10 \mu\text{g ml}^{-1}$, but as harmful as Triton X-114 at the $50 \mu\text{g ml}^{-1}$ level. Noteworthy, is a technical report from the Rohm and Haas Chemical Company [135], listing the surface active properties of the Triton

octylphenol series. Triton X-100 would reduce the surface and interfacial tension in a more efficient way than Triton X-114, thus being a better wetting agent. Hence the latter studies and our own have shown that a small increase in the number of ethylene oxide units of the higher ethoxylate Triton adjuvants (X-114 and X-100) does not always implicate a concomitant decrease in the phytotoxicity.

Surfactants of intermediate ethylene oxide units from the Triton octylphenoxy series have been found to enhance Mn or Zn absorption to the greatest extent in soybean leaf disks [136]. Neither the surface tension, interfacial tension nor the HLB values could directly be associated with enhanced Mn or Zn absorption. In a similar study [131], however, iron uptake increased in direct proportion to HLB values in the range of 4.3 to 15.0 for the nonionic surfactant family sorbitan monooleate. In this latter study, a curve of best fit illustrating the relationship between accumulation index and HLB indicates the optimum HLB values for members of three similar nonionic surfactant classes (ethoxylated fatty acids) to range from 13 to 16. Optimum effect is usually observed at the same HLB in all chemical families but the HLB may vary if the system (carrier) is different [137].

Results from the growth experiment, however, have in themselves clearly demonstrated that toxicity of the lower (X-15 and X-35)

and higher (X-114 and X-100) ethoxylate Triton adjuvants is a function of the number of ethylene oxide units. This is in agreement with findings by Sirois [138] and Buchanan [139], who observed a decrease in toxicity with increasing molecular weight of the hydrophilic polyethylene glycol radical of some non-ionic surfactants. It was found that Triton surfactants induced accumulation of phytoalexins in cotyledons of the French bean Phaseolus vulgaris L. [140]. The surfactant ethylene oxide unit number dependent phytotoxicity determined the degree of accumulation. The range of phytotoxic parameters used in this investigation has enabled a more rigorous toxicological evaluation and thus we can better ascertain that an increase in the ethylene oxide units in the Triton adjuvant series is concomitant with a decrease in phytotoxicity. This study to our knowledge, is one of the first to have used a range of phytotoxic parameters, as previous studies [6,130,132,136,141], have based their work on very few parameters such as biomass reduction over a relatively short span of the organisms' life cycle.

Results of the present investigations have clearly indicated that all phytotoxic parameters were more affected by the lower ethoxylates than the higher ones. Further, there may be a difference among the individual parameters, where conductivity, giving an indication of ion fluxes, is the most affected followed by fluorometry, frond number, dry weights and chlorophyll content respectively. A statistical test could not be performed to verify

this difference, due to the heterogeneity of the variance between the individual parameters. The data demonstrate that phytotoxic effects are a function of the number of ethylene oxide units, however, the data have not given a numerical order to the Triton adjuvants, relating their phytotoxicity to their hydrophilic lipophilic balance. What has been done, is to group the Triton adjuvants into lower and higher ethoxylates and to ascribe toxic levels to each group, these levels being dependent on the phytotoxicological parameter under investigation.

B) K_{OW} :

To date, the K_{OW} is one of the most useful values in the study and development of new chemicals. It has been used to predict the fate and distribution of chemicals in biota [38,142] and their potential for accumulation [37]. In the present study it was clearly demonstrated that phytotoxicity of the selected adjuvants used in the fenitrothion formulation at a field exposure concentration of $10 \mu\text{g ml}^{-1}$, increases with increasing $\log K_{OW}$. Based on the original concept of Hansch concerning K_{OW} , Chiou et al [35] have derived an equation relating K_{OW} with water solubility:

$$\log K_{OW} = 5.00 - 0.67 \log S$$

where S = water solubility in water expressed in $\mu\text{mol L}^{-1}$. The K_{OW}

values for the adjuvants used in this study are shown in Table 4 along with the water solubilities and bioconcentration factors (BCF). As previously mentioned, it was stated by Zitko and McLeese [37] that values of $\log K_{OW}$ greater than 4.5 indicate a potential for considerable uptake of the chemical by aquatic fauna. Triton X-15 with a $\log K_{OW}$ of 4.74 did indeed cause extensive perturbation in Lemna. From the radiolabelled studies, the BCF or the ratio between the adjuvant concentration found in the plants and that found in the media, was substantially greater (factor of 4) for X-35 than X-100. Hence a correlation exists between the bioconcentration, the K_{OW} , the water solubility and the phytotoxicity of the Triton adjuvants. Such relationships have been the focus of many studies [35,38,39,40]. Investigations on bioaccumulation of lipophilic compounds by fish have indicated that uptake and clearance rate constants have a fixed relationship to the octanol/water partition coefficient over the partition coefficient range $\log K_{OW}$ 2.5 - 6 [143]. The bioaccumulation that is observed in one kind of organism, however, does not describe the bioaccumulation in all types of organisms because of the morphological and physiological differences. Lockhart et al. [40] have described the uptake and toxicity of several organic compounds by Lemna minor. They derived a regression equation from laboratory data which describes the bioconcentration of ten compounds with a wide range of physical properties. The derived equation is as follows:

$$\log \text{BCF} = 0.491 \log K_{\text{OW}} + 0.0562$$

BCF is the bioconcentration factor in Lemna, and K_{OW} is the octanol/water partition coefficient for the compound under study. The equation is, however, limited to short exposure times (4 - 5 days), six orders of magnitude in K_{OW} , and compound concentration ($0.3 - 59.7 \text{ ng ml}^{-1}$). Fitting the Triton series into this equation gives a BCF of 242, 42, 5.9 and 4 for Triton X-15, X-35, X-114 and X-100, respectively. In the present investigations the BCF for X-35 and X-100 after a two week treatment period were found to be 156 and 39, respectively. The above equation cannot be extrapolated to 14 days, however, these data indicate that Triton X-35 is bioaccumulated considerably more than Triton X-100 even after a 14 day treatment period. Noteworthy is the fact that Dowanol was used to carry the Triton surfactants in the medium mixture. It enabled the use of a homogeneous mixture, especially with the lower ethoxylate Tritons X-15 and X-35. Without the use of Dowanol, these Triton surfactants partition at the surface of the mixture where they are in a much greater concentration than that calculated from their molarity.

2) Predictive models:

From the previously mentioned discussion it is evident that general predictive models based on specific chemical determinants of an array of chemicals are difficult to establish. Although

predictive models are not the focus of this study, the status of compartment model systems [37,144,145], pattern recognition (PARC) and quantitative structure-activity relationships (QSAR) [146,147,148,149,150,151] are noteworthy as these are pertinent to the present study. General conclusions in these areas attest that with QSAR, the first level of PARC, one can derive mathematical models accounting for the transport, metabolism and receptor interaction of particular xenobiotics [146]. The models, however, are limited in their predictive ability. These limitations include, the extent to which biological mechanism and physicochemical property descriptors of chemicals have been explored [146]. Thus there is a need to include mechanistic models such as that proposed earlier in this study (see model page 31).

As in the present investigations, emphasis in QSAR analysis is placed on the parameter of lipophilicity of chemicals, most widely measured by partition coefficients. Other factors devised in the correlation of partition coefficients are entropy and enthalpy of partitioning [148], molar volume, molecular surface area, molecular weight [148], and hydrogen bonding measured from molecular connectivity indices [30]. These factors are generally part of other rarely estimated parameters which include molecular electronic and steric effects, reflecting the reaction rates/ionization and quality of fit of xenobiotics, respectively [146]. Factors with properties relating to the bulk/size of molecules generally have an inverse relationship with K_{OW} and hence

are more toxic. This is generally true for apolar molecules [148]. In the case of the ethoxylated phenoxy alcohol surfactants, however, this does not apply.

Another advantage of QSAR, apart from mathematical modelling, is the systematic approach which can be taken in the evaluation of new chemicals prior to their introduction into the environment.

General effects on plant physiology:

The floating aquatic macrophyte Lemna has a cuticle on the surface exposed to the air. Its submerged side is the site of absorption and lacks a cuticle. Instead, a porous cell wall and a plasmalemma serve the plant in its absorption of nutrients and selective permeability [12]. As in root systems [152], this lower surface would hence be more sensitive to surfactants.

In the present study, it is conceivable that the more lipophilic surfactants displayed their effects at the outer membrane level of organization as indicated by effects on ion fluxes and differences in electrolyte leakage.

A trend towards an increased uptake and retention of some electrolytes, for example K^+ , is observed one week after treatment. These findings are in agreement with those of Haapala [62] who found a lessening of solutes in the bathing medium or an increased influx of solutes in beet tissue. In the present study,

it was found that following a two week treatment period, a time period representative of chronic exposure, electrolytes leaked into the bathing medium in all treatment sets. This leakage was concomitant with an increase in the conductivity of the bathing media. It would seem the increases in ionic charge content observed with the conductivity measurements of treated sets was reflected mostly by an increased efflux of K^+ ions since these are the predominant electrolyte.

Effects on ion absorption and translocation are suggested to be an important symptomatic determinant of more specific toxicological effects [152]. In the present study, an altered cell permeability is concurrent with a decrease in the photosynthetic activity as quantified by fluorescence measurements. This effect is evident with the hydrophobic adjuvants, however, it remains to decipher whether it is direct or indirect. The mode of action of two polyether type surfactants has been postulated to be either a direct interaction with membranes, and/or an indirect intervention with cellular energy generating systems that maintain membrane integrity [58]. It was observed by St. John et al. [63] who investigated surfactant effects on isolated cells of soybean and wild onion that a correlation existed between altered cell permeability and the inhibition of photosynthetic fixation of $^{14}CO_2$. In their study, photosynthetic inhibition was more sensitive than cell permeability. The authors suggest that surfactant effects are not solely restricted to the outer

plasmalemma. In a study by Horowitz and Givelberg [59], specific injury symptoms on the leaves of sorghum were described as "hunger signs" induced by differential leaking from the root system.

In the present study, since the concentrations used were exposure concentrations and these are below the critical micellar concentration (CMC), a crude detergent-like solubilization of membranes was not the mechanism by which the perturbant effects were induced. Further, no change in pH of the bathing media and no exudation of amino acids were observed (Appendix G). In order to elucidate the mode of action of these types of adjuvants on plant membranes, studies were undertaken on membrane lipid dynamics of Lemna minor following exposure to the Triton adjuvants. In parallel experiments the composition of the different classes of lipids was also monitored following exposure to the four Tritons.

Effects on membrane physiology and fluidity:

1) Lipid analysis:

The lipid composition of Lemna for each of the lipid classes has been compared with those obtained by Grenier et al [86]. They were found to be very similar. The phospholipid content ($53\% \pm 2\%$) was however found to be 10% less than that found by these authors.

The present investigations have shown that adjuvants affect the turnover of membrane components in Lemna, as the total phospholipids decreased and the total galactolipids increased. A further unsaturation effect was observed on all the lipid classes analyzed and also on the individual phospholipids with the exception of DGDG. These results demonstrate that the Triton adjuvants at field exposure concentrations do indeed act on the membrane systems as we originally hypothesized. In concordance with these results, it was shown by Nyberg and Koskimies-Soininen [82] that a decrease in the level of saturation of both MGDG and DGDG fatty acids in Porphyridium purpureum was observed after treatment with Triton X-100 and sodium desoxycholate (SDC) at a concentration of $20 \mu\text{g ml}^{-1}$. They found all detergent treatments to increase the MGDG/DGDG ratio. We found this ratio to be slightly increased, however, not significantly. This ratio has been shown to be generally low in algae (approx. 0.35). In Lemna, it was found to be close to 1.7 in control plants. This result is in agreement with that found by Grenier et al. [86] who reported a value of 1.5 in Lemna membranes. Since DGDG show a preponderance in algae [153], an increase in the MGDG/DGDG ratio is probably due to a decrease in the amounts of DGDG [83]. This further substantiates the fact that each species has its own peculiarities and that the mode of action of adjuvants will differ between species.

It was also suggested in this study that the more hydrophobic adjuvants would affect the lipids of the plasma membrane inducing their unsaturation, whereas the effect of the hydrophilic adjuvants would be targeted at inner membranes. The hydrophobic and hydrophilic moieties of these adjuvants and their non-ionic character tend to mimic membrane lipids. Hydrophobic adjuvants cannot permeate through the plasmalemma as quickly as the hydrophilic adjuvants. The hydrophobic adjuvants are more lipid soluble and would essentially be trapped in the lipid bilayer of the plasmalemma. Hydrophilic adjuvants have a greater number of hydrogen bonds with water thus rendering them more soluble and hence less toxic.

In the assessment of effects on total lipids, none were observed on the total lipid content, however, significant differential effects between treatment adjuvants were evidenced on oleic acid (18:1). It is suggested the lower ethoxylate Tritons (X-15 & X-35) may induce stearoyl-CoA desaturase in a preferential manner in total lipids. Our studies on the individual principal phospholipids has shown the absolute amounts of PC and PE to increase with a concomitant decrease in PG and PI when these are compared to controls. The fluctuations observed in the lipid ratios of the treated to non-treated plant tissues have a direct correlation with the chain length or the number of ethoxyl units in the hydrophilic moiety of the Triton adjuvant.

By plotting the lipid ratios between treatments and controls (Figure 17b & 18b), in the case of the higher ethoxylates (X-100 and X-114), it is observed that the lipid assays are "sensing" a discontinuity in the normal inhibitory effect associated with a decrease in the chain length. This discontinuity was also observed with the phytotoxicity parameters (Figure 14a & 14b). K_{OW} has its limits as it does not give details about many of the chemical and physical properties of the adjuvants. Thus, there is a need to investigate the possible presence of a new chemical parameter in the Triton adjuvants which would better explain what is observed by the biomonitors such as the ones used in this study.

While it is not in the scope of this study to discuss lipid biosynthesis, fluctuations in lipid ratios are further evidence that substantiates membrane lipid component turnover. Studies of herbicide effects on Chlorella lipid biosynthesis [154], reported that Hill reaction inhibiting herbicides markedly decrease the proportions of MGDG and DGDG while increasing those of PE and PG. Other lipid proportions decreased.

In the present study, all phospholipids show a decrease in the degree of saturation. Further, the unsaturation of phosphatidyl ethanolamine (PE) is more significantly affected by the lower ethoxylates than the other phospholipids. PE is a phospholipid in membrane systems other than chloroplasts [88]. Unlike the other

phospholipids, PE forms hexagonal phases (inverted micelles) which give it special properties. Recently, it has been suggested to be directly involved with transbilayer "flip flop" [155] and membrane fusion [156], hence its concentration in the plasmalemma, Golgi apparatus and other vesicular structures which adhere to cellular components. It is clear that the Triton adjuvants induce a chemical perturbation in Lemna membranes (extra and intra cellular). In order for such a phenomenon to occur, a concomitant physical perturbation must also be induced whereby the non-ionic adjuvants would most likely intercalate in the membrane systems, perturbing and compressing the membrane components. Spectrophotometric investigations (Appendix E) have demonstrated the Triton adjuvants to be highly incorporated in the membrane of chloroplasts. Radiolabelled investigations herein have shown both hydrophilic (X-100) and hydrophobic (X-35) adjuvants to bind to the membranes of chloroplasts.

It was observed that as the membrane lipids of root chloroplast exposed to herbicide increase in their saturation, a concomitant decrease in membrane fluidity and increase in permeability occurs [157]. Our results clearly demonstrated that a decrease in Lemna chloroplast lipid saturation brought about an increase in membrane fluidity and an increase in permeability. Both these results are a consequence of perturbances on membrane stability.

2) Membrane fluidity:

The dynamics of the chloroplast membranes, as assessed by anisotropy measurements, indicated that these are rendered more fluid by the lower ethoxylates and more rigid by the higher ethoxylates (Figure 20). Treating chloroplasts after their isolation has undoubtedly exposed the chloroplasts to greater concentration of surfactant than those they would be subjected to in intact cells. This probably accounts for the difference in magnitude observed in the anisotropy measurements. The natural membrane selectivity of whole organisms with intact membrane systems is disrupted in fractionation procedures further accounting for this difference in magnitude.

Increases in membrane fluidity, as observed in the present investigations, concur with the increased unsaturation grade of membrane lipids. By acting through changes in the fluidity of the membrane, the fatty acid desaturase enzymes are either turned "on" or "off" by a low concentration of the adjuvants as is the case for the membranes of the temperature sensitive Tetrahymena [158]. In the present case, however, an in situ unsaturation is just as probable as a heat triggered sequential unsaturation of membrane lipids initiated at the endoplasmic reticulum [111]. The fact that the Triton adjuvants have been shown in the present investigations to be incorporated with the lipid component of cells support the former suggestion. Mechanisms of lipid-linked unsaturation,

deacylation, desaturation and reacylation are a field of active research [159,160,161,162,163,164], hence, speculation on the direct involvement of adjuvants on these systems remains wide open.

Lipid domains in membranes is also a fairly recent and active research area [165,166]. Phosphatidyl serine domains are negatively charged and upon contact with Ca^{2+} tighten up against each other. Any protein caught in this domain is in a way restricted and can now perform an enzyme activity if it is in a complex, as in the acyl desaturase enzyme complex [162].

It is suggested the surfactants used in this study intercalated in membrane systems, perturbing and compressing their normal lipidic constitution. A consequence of this is a possible activation of the desaturase enzyme complex or a perturbation of other de novo membrane lipid synthesis enzyme systems and regulation mechanisms which have the overall effect of altering membrane fluidity. The phenomenon of desaturation is described by Pugh and Kates [162] and involves a direct desaturation of acyl chains in lipids. This occurs by a membrane-bound enzyme system using O_2 , NADH and CYT b_5 as cofactors (see model page 33).

At the onset of treatment, hydrophobic surfactants may act to a greater extent on the outer plasmalemma, but in due course these permeate into the organism intercalating into, and causing direct

damage on, inner membrane systems such as the chloroplasts. The uptake studies further support this evidence.

These investigations have shown the lipid components of Lemna to vary under adjuvant induced stress. A desaturase enzyme of Lemna may have been induced by the presence of the adjuvants impinging on membrane systems accounting for the increased level of lipid unsaturation. Further direct evidence, however, is warranted to substantiate this fact as other acyl chain modification mechanisms are known [167]. The lower ethoxylate Triton adjuvants invoked a greater unsaturation in phosphatidyl ethanolamine, a phospholipid found in membranes other than chloroplast membranes. Monitoring the dynamics of chloroplast membranes treated before and after their isolation, witnessed the hydrophobic Tritons (X-15, X-35) to invoke a greater fluidity than the hydrophilic Tritons (X-114, X-100). Hence, it is suggested that the non-ionic hydrophobic Triton adjuvants at field exposure concentrations have a direct effect on the inner membrane systems of Lemna minor.

CONCLUSIONS

Dowanol is considered to have no significant irreversible toxicity for Lemna minor at field exposure concentrations ($1 \mu\text{g ml}^{-1}$) and at 96.5, 482.5 and at $965 \mu\text{g ml}^{-1}$. Since the toxicity of Dowanol to Lemna and several other organisms [42,43,44,124] occurs at concentrations about three orders of magnitude higher than observed field concentrations [43], this adjuvant is hence judged to be of low environmental risk at field relevant concentrations when used as a co-solvent carrier.

Field relevant concentrations ($10 \mu\text{g ml}^{-1}$) of Triton X-100, X-35 and X-15 are toxic to Lemna. The lower ethoxylates, Tritons (X-15 and X-35), elicited approximately 2-fold greater depression of the physiological parameters assessed than treatment with the higher ethoxylates, Tritons (X-100 and X-114). The bioconcentration factor for Triton X-35 and X-100 were found to be 156 and 39 respectively, a 4-fold difference.

Phytotoxicity of the adjuvants tested was positively correlated with octanol/water partition coefficients and with their hydrophilic lipophilic balance (HLB). The sequence of increasing effects of the Triton series was Triton X-15 > X-35 > X-100 > X-114. From a toxicological point of view, Triton X-114 is hence recommended for use as a less hazardous emulsifier.

Field exposure concentrations of the Triton adjuvants perturbed the membrane integrity of whole Lemna plants, both physically and chemically. A decrease in the content of the total phospholipids and a concomitant increase in the content of the galactolipids was observed. Further, a unsaturation occurred in the fatty acids of the total lipids, phospholipids and monogalactosyldiglycerides following exposure to all the adjuvants. A differential Triton effect was evidenced on the unsaturation grade of phosphatidyl ethanolamine. The hydrophobic adjuvants (Tritons X-15 and X-35) induced a greater unsaturation than the hydrophilic adjuvants (Tritons X-114 and X-100).

Membrane dynamics were also perturbed as the fluidity of the chloroplast membranes as measured by fluorescence polarization increased. This increase was correlated with the adjuvants' HLB.

The association of the adjuvants with membrane lipids together with their biophysico-chemical perturbant effect on membranes, has led us to suggest that the adjuvants' mode of action is direct, and that the mechanism by which effects are induced may be through an in situ physical displacement of lipids directly involved with desaturase enzyme systems.

Suggestions for future research:

- 1) The present toxicological laboratory studies should be followed by ecological studies. These would predict the risk factor involved by the environmental application of xenobiotics in a much more comprehensive manner.
- 2) Biodegradation/persistence studies in the field would be very important to monitor as the role of microorganisms and abiotic factors may be consequential in the overall xenobiotic effect.
- 3) Research is needed in the areas of surfactant environmental monitoring (including methodologies), identification, dispersal/fate, recovery and disposal/transformation, since investigations into these are scarce and currently of prime importance.
- 4) Biochemical studies are required on the interactions and effects of low surfactant concentrations on macromolecules such as DNA, proteins and lipid/protein complexes in the cells and organelles of a selection of surfactant exposed organisms. These could be correlated with new chemical/physical parameters which would better explain discontinuities that the present parameters could not. These studies would have for aim to increase our knowledge on the mode of action of surfactants which in turn would further the accuracy of predictive models.

The following are examples of the framework for distinctive projects in these previous areas of research:

A) A study on the species diversity of lake-shore vegetation stressed by presence of adjuvants. The study would include the monitoring of both biotic (algae content) and abiotic factors such as sediment composition and water quality (pH, conductivity, suspended matter).

B) A study to investigate the dispersal rate of radiolabeled adjuvants in different soils. The study would incorporate the effects of leaching (rain), caging, and physical and biological degradation such as photolysis and the involvement of microorganisms.

C) Similarly, a study employing predictive models and surfactant monitoring systems such as the PPAS/MBAS¹ ratio in waters polluted by urban liquid waste to investigate the dispersal and ultimate fate of surfactants in aquatic systems.

D) 1: A study probing into the possible role proteins may play in the overall surfactant effect. The study could focus on

¹PPAS/MBAS ratio: A ratio between the concentration of non-ionic surfactants determined as Potassium Picrate Active Substances (PPAS) and the concentration of anionic surfactants determined as Methylene Blue Active Substances (MBSA).

the specificity with which a particular surfactant extracts proteins from cellular membranes.

2: A study investigating surfactant physical and chemical effects on different cellular membranes. A time scale/pulse chase design could be adopted which would give some insight into the unsaturation phenomenon. Since it is thought more lipophilic compounds would not travel in the aqueous cytoplasm, the only means that would be available to them in order to reach cellular organelles such as the endoplasmic reticulum, the mitochondria and chloroplasts are lipid rich phases. To this end they may adhere to proteins (lipoprotein complexes), to free fatty acids, and may even travel within membrane networks. The utilization of radiolabeled surfactants in the design of a time based experiment which would monitor surfactant accumulation into cellular organelles may provide some information regarding surfactant organelle accumulation and effects.

APPENDIX A: Dowanol molecular formula determination

Dowanol TPM: (Tripropylene glycol methyl ether)

Molecular formula: $\text{CH}_3\text{O}[\text{CH}_2\text{CH}(\text{CH}_3)\text{O}]_3\text{H}$

: $\text{C}_{10}\text{H}_{22}\text{O}_4$

Molecular weight: 206.3

Boiling point: 242.4 °C

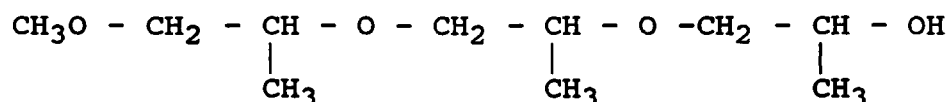

- Asymmetric centres at the CH
- Hydroxyl group - active group

SPECTRAL DATA

(A) Mass spectra

1) Fast Atom Bombardment Spectrum (FAB) is a relatively new technique used to examine liquids and compounds which may be difficult to analyse. A FAB spectrum of Dowanol TPM is shown in Spectrum 1. This spectrum is quite complex suggesting that the sample is a mixture. The main ion at 207.2 m/z is the M+1 ion for Dowanol. This is confirmed by the presence of an ion at 299.2 m/z

representing the $M+1$ +Glycerol and an agglomerate ion ($2M+1$) at 413.2. Two other ions at 265.2 and 277.2 m/z possibly represent the ($M+1$) ions of other compounds in the liquid sample.

2) Gas Chromatography/Mass Spectroscopy

Mass spectra are commonly determined in the electron impact mode where the sample is bombarded with electrons resulting in extensive fragmentation of the molecule. This forms a fingerprint of the molecule which is unique for a particular compound, however, it often results in a weak or non-existent molecular ion. In order to overcome this problem, spectra are often run in the Chemical Ionization mode (CI), which is a "softer" form of irradiation being carried out in the presence of reagent gases like methane, or ammonia and result in strong molecular ions.

Spectrum 2 shows a Reconstructed Ion Chromatogram (RIC) of Dowanol in the CI mode. It confirms the fact that the Dowanol sample is a mixture of an approximate purity of 76%. The main product peak is observed at a scan time of 5:15 min together with minor peaks at 4:34, 5:06 and 5:22 min.

The MS of the major peak with a scan time of 5:15 is shown in Spectrum 2a. It has a molecular ion of 207 m/z ($M+H$), corresponding to Dowanol. It also shows an ($M+H-18$) ion which corresponds to the loss of water and is consistent with the

presence of a hydroxyl moiety existing in the molecule.

The RIC also shows two impurities close by the main peak i.e. 5:06 and 5:22 min (Spectrum 2). These two compounds both have molecular ions of 207 m/z (Spectrum 2b and 2c) and have similar fragmented ions to those in Dowanol (Spectrum 2a). This indicates that they are isomers of Dowanol, since it is well known that the MS of isomers are very similar, differing only in the intensities of the fragmented ions.

The RIC shows one other small impurity at 4:34 min (Spectrum 2). A main ion (M+1) is observed at 113 m/z (Spectrum 2d) and the spectrum does not have similar fragmented ions to those in Dowanol (Spectrum 2a) confirming this ion to be a small impurity.

(B) ^1H and ^{13}C Nuclear Magnetic Resonance Spectra

Nuclear magnetic resonance spectroscopy compliments MS and is able to provide information on the number of atoms present in a molecule as well as the conformation of molecules. The ^1H NMR and ^{13}C NMR of the Dowanol TPM sample are shown in Spectra 3 and 4 respectively. They are consistent with the structure of Dowanol. The number of peaks in the ^{13}C spectrum exceeds 10, again indicating the presence of impurities in the sample. The main drawback of NMR is that it is a lot less sensitive than MS, which does not represent a problem in this particular case.

Instrumentation:

1) GC/MS: Mass spectra were obtained on a Finnigan GC/MS system, Model 4500, operating in the chemical ionization mode (CI) mode. The Dowanol sample was separated on a DB-5 fused silica capillary column (20 m X 0.32 mm (i.d.), 0.25 μ m film). All samples were injected on-column. The GC conditions are as described in the materials and methods section.

2) NMR: ^1H and ^{13}C NMR spectra were run on a Bruker WM 500 MHz spectrometer. The ^1H spectra were acquired with 16K data points, a 2200 Hz spectral window, 60° pulses, and 10 s repetition time. Chemical shifts are referenced to deuteriochloroform at 7.24 ppm and are reported relative to tetramethylsilane.

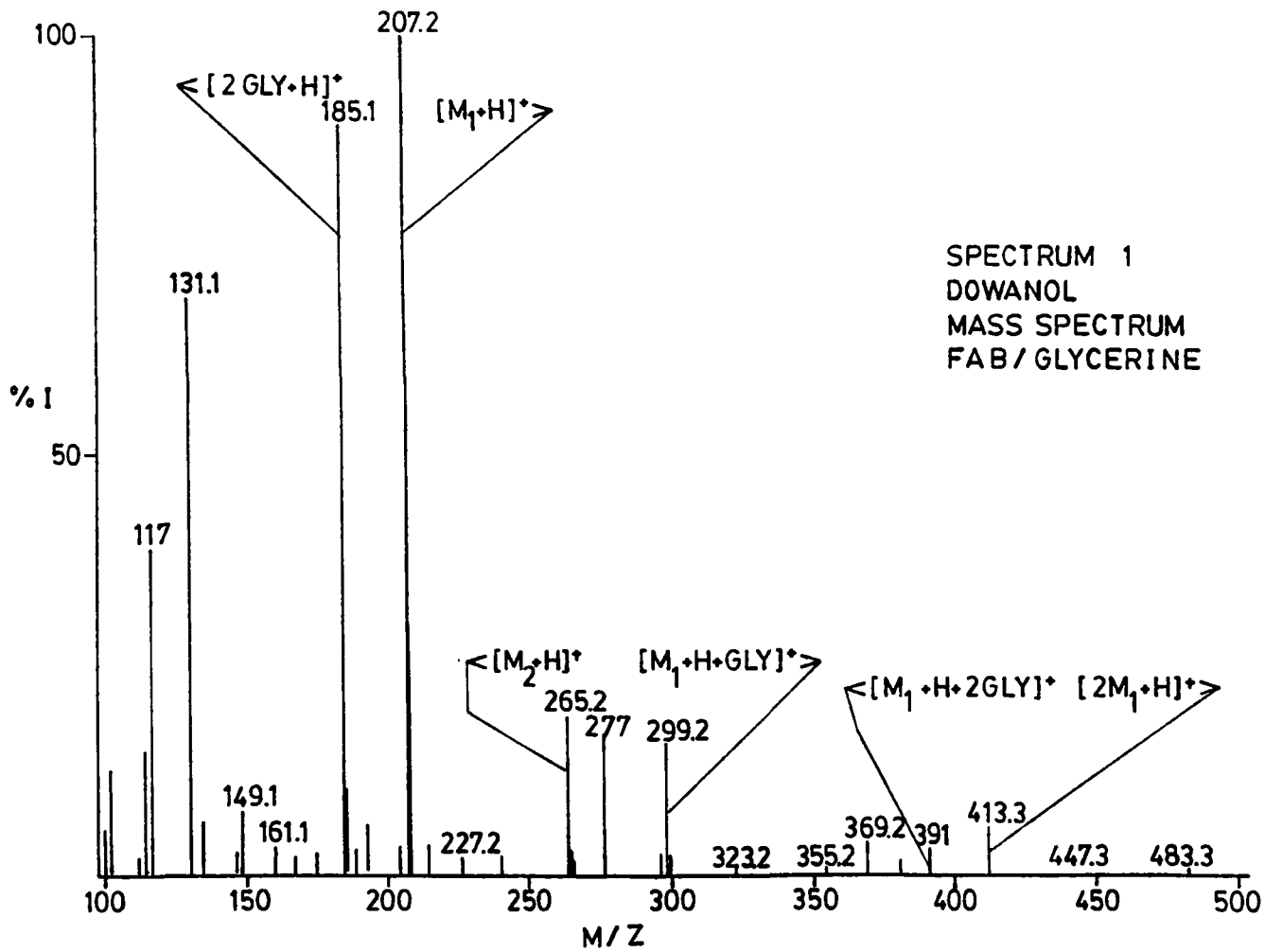

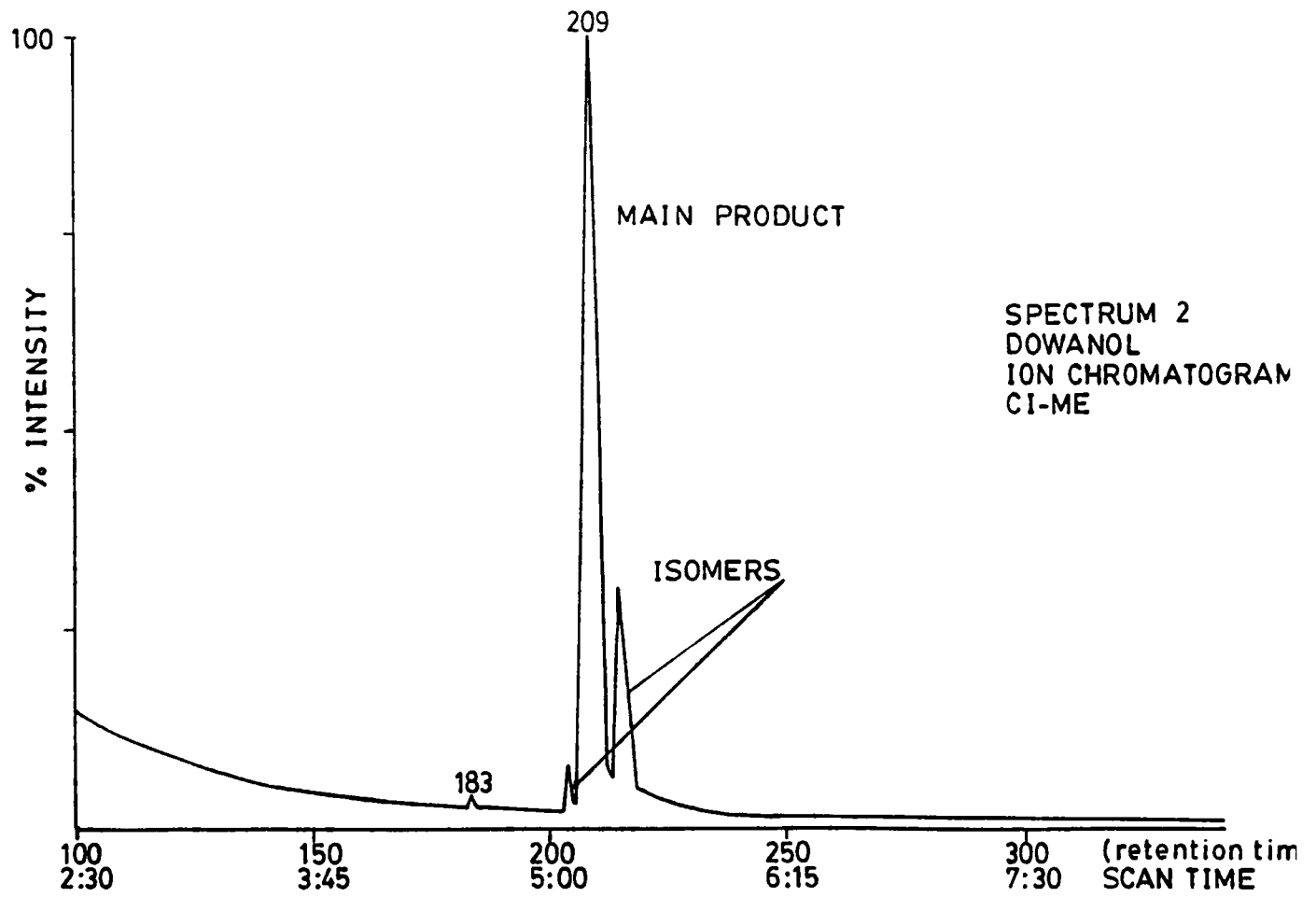

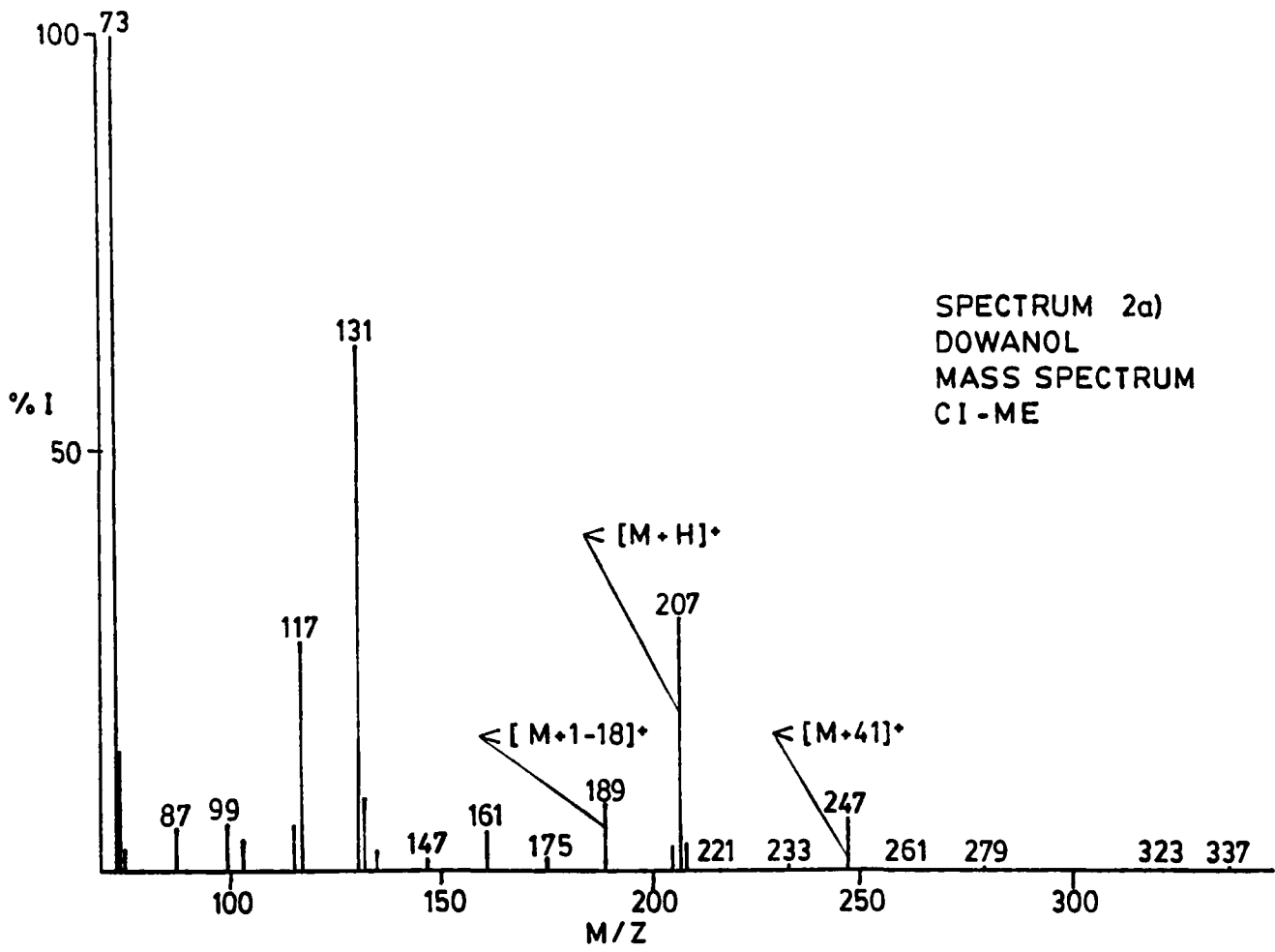

SPECTRUM 2a)
DOWANOL
MASS SPECTRUM
CI-ME

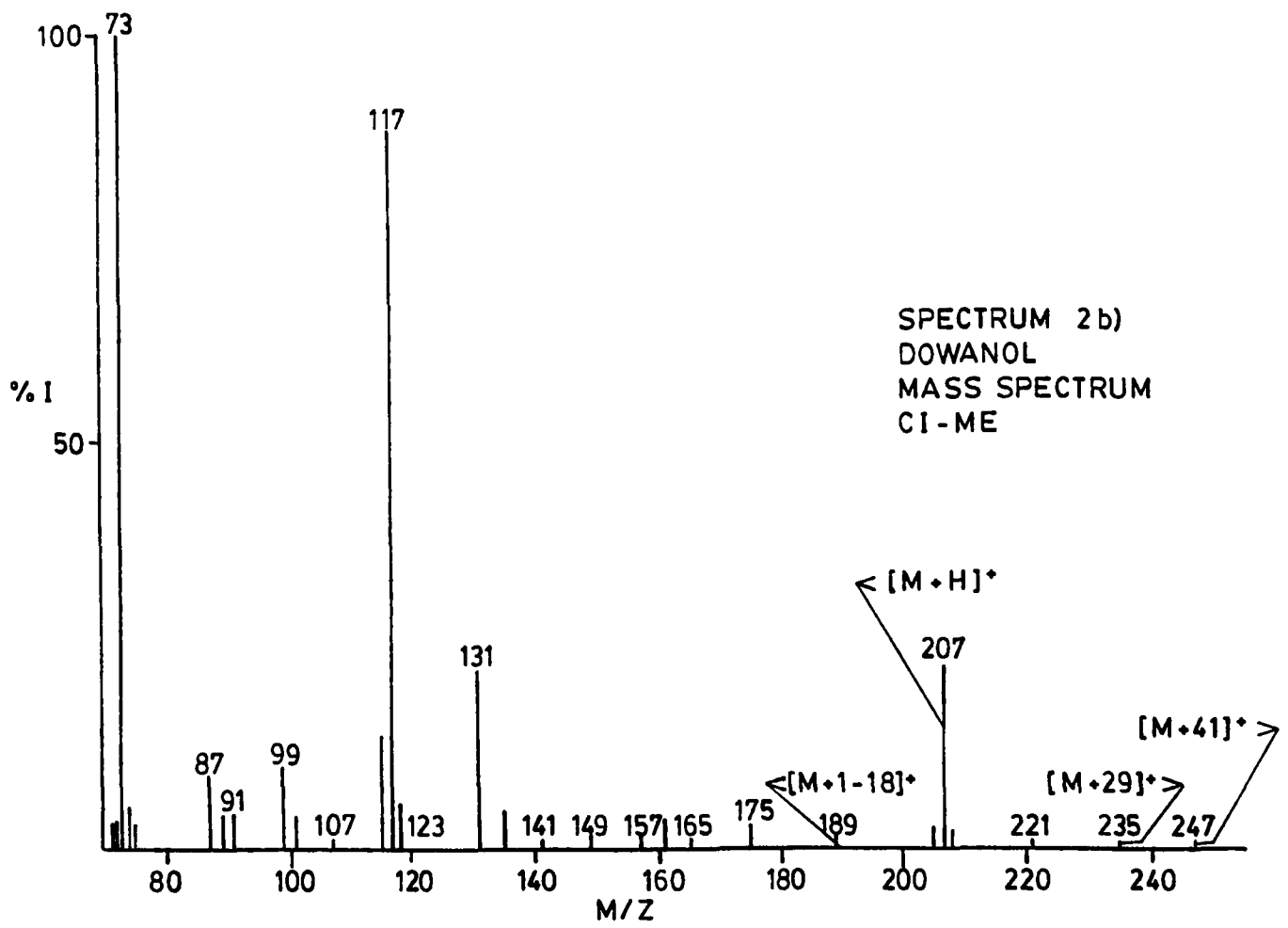

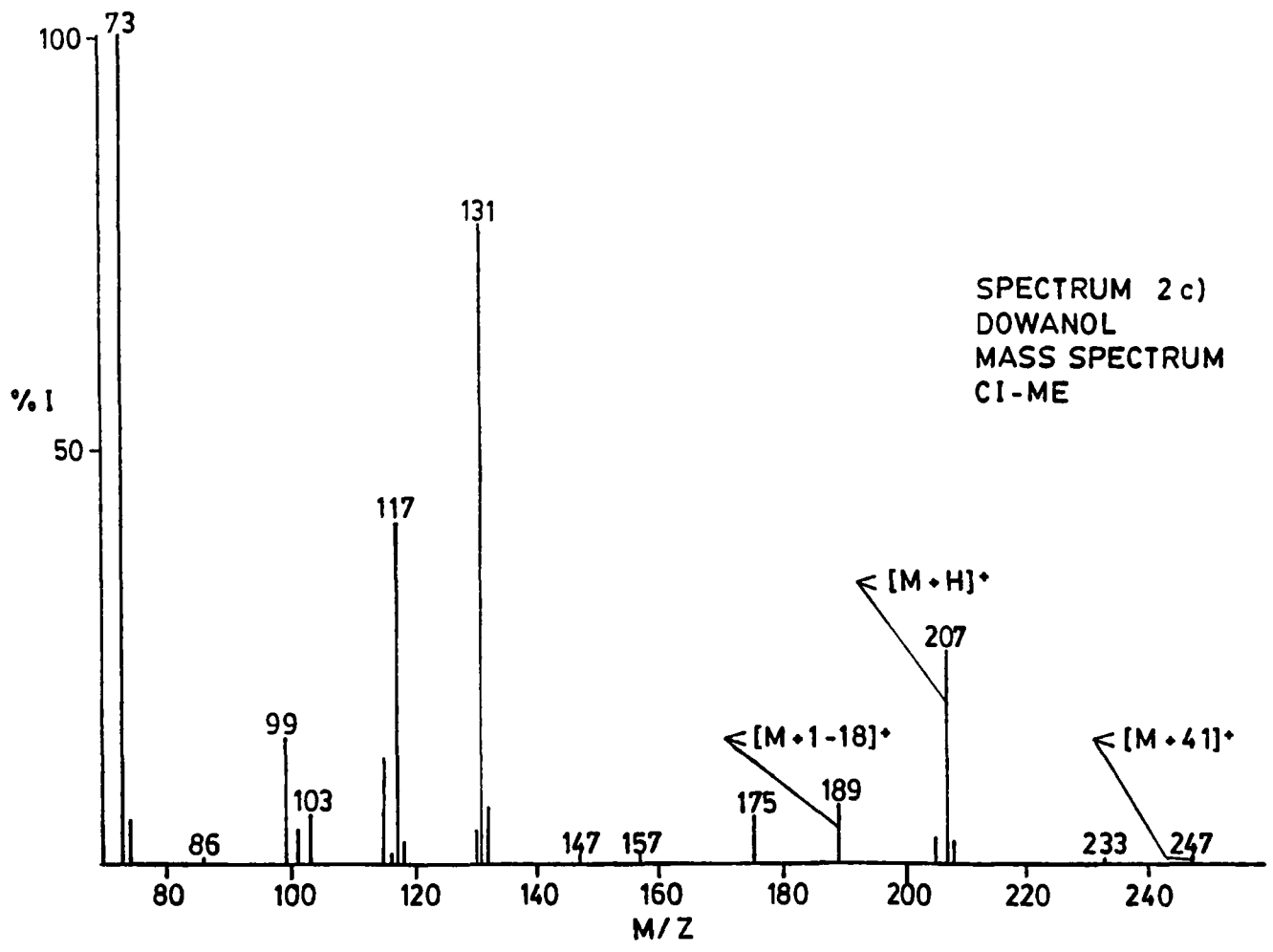

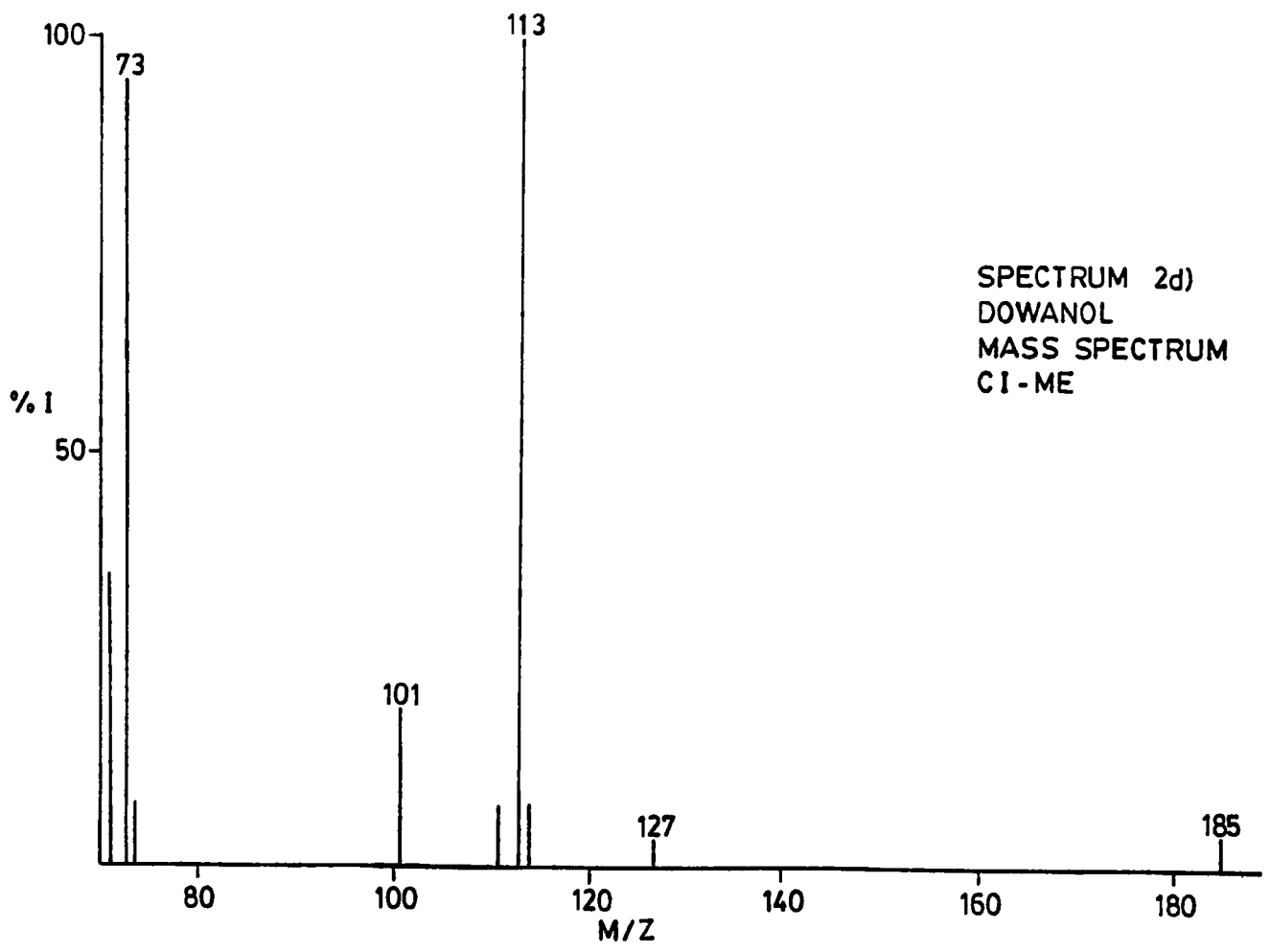

SPECTRUM 2d)
DOWANOL
MASS SPECTRUM
CI-ME

SPECTRUM 3

DOMANOL PROTON SPECTRUM

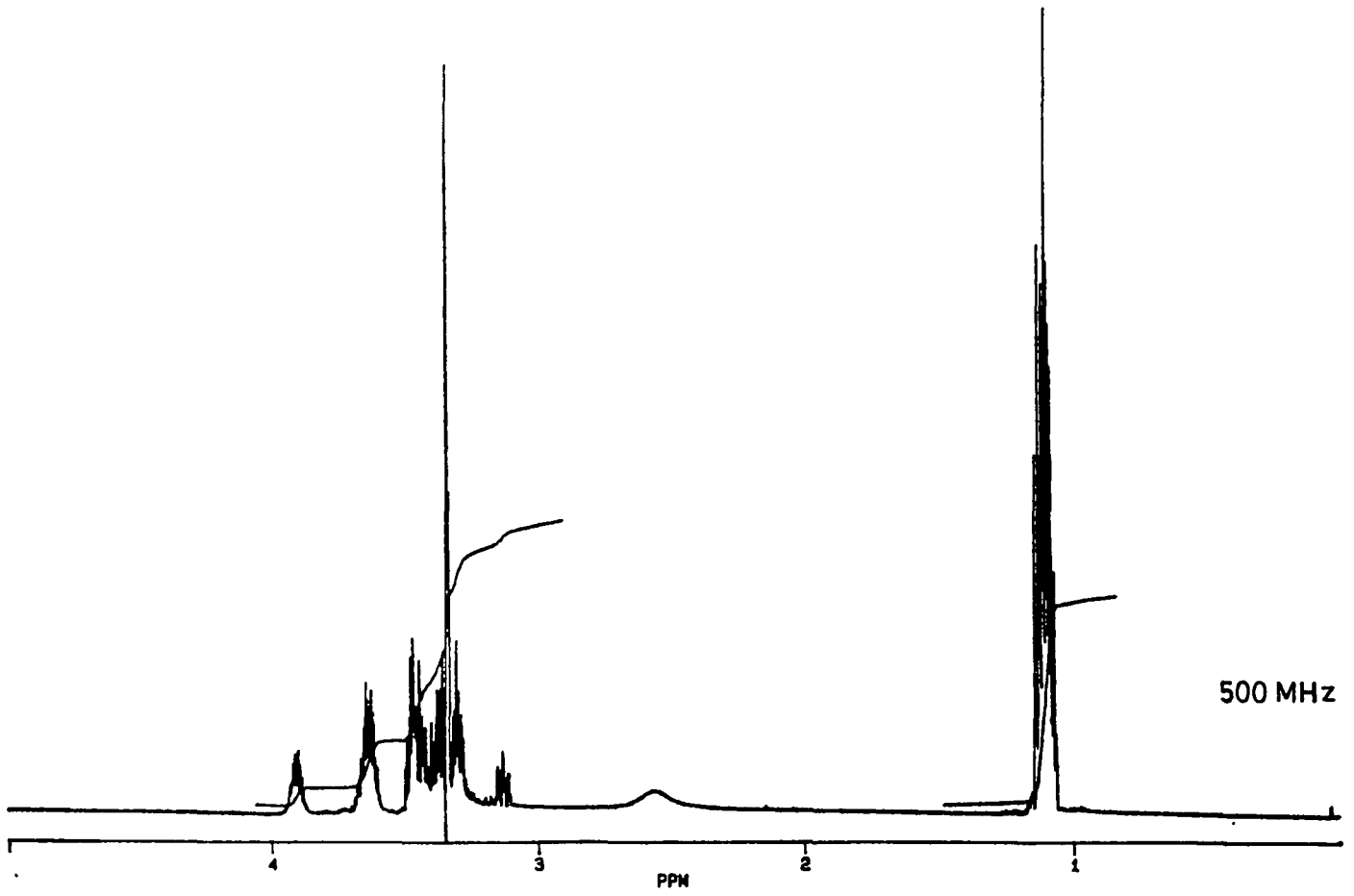

SPECTRUM 4

DOMANOL, C-13 SPECTRUM

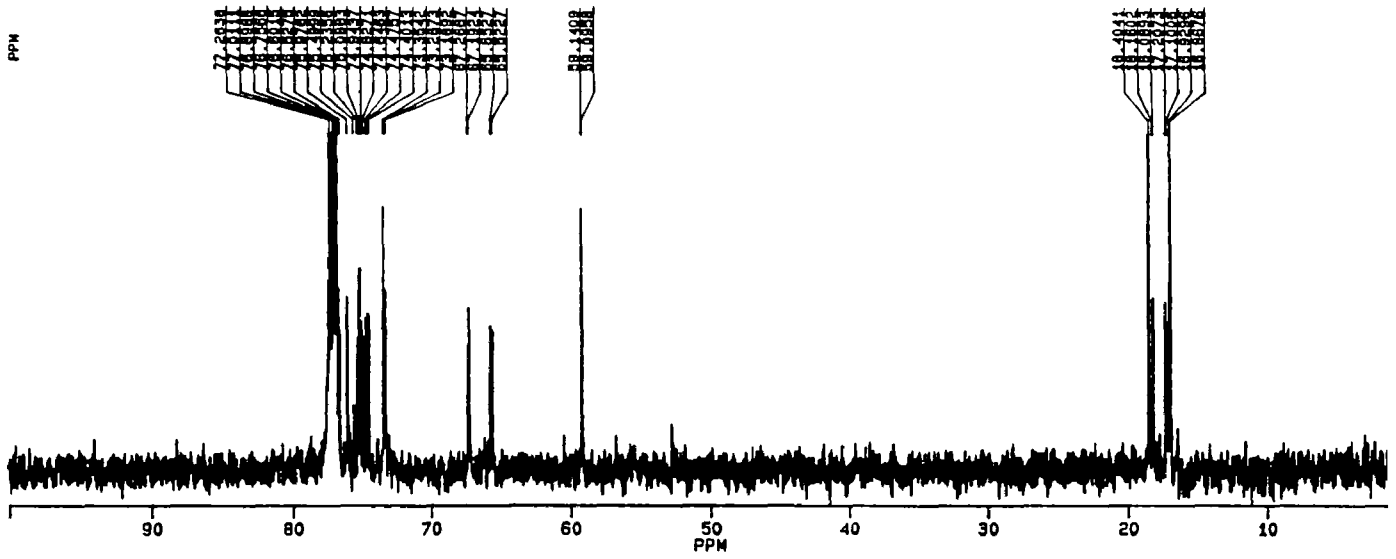

APPENDIX B: Triton structure determination

Triton: Alkyl aryl polyether alcohol (polyether/ethoxy alcohols)

Triton:	X-15	X-35	X-114	X-100
Mol. Wt.:	250	338	514	602
Density (g L ⁻¹): at 25°C	984	1020	1056	1068
CMC (μg ml ⁻¹):	98	102	106	107
CMC (μM):	393	302	206	178
Surface Tension (ST) H ₂ O 25°C dynes cm ⁻¹ at 0.01% (CMC)	-	29	30	31
ST at 0.001%	-	32	44	46
HLB:	3.6	7.8	12.4	13.5
# of ethylene oxides units (EO)	1	3	7 - 8	9 -10
Mol. formula:	C ₁₆ H ₂₆ O ₂	C ₂₀ H ₃₄ O ₄	C ₂₈ H ₅₀ O ₈	C ₃₂ H ₅₈ O ₁₀

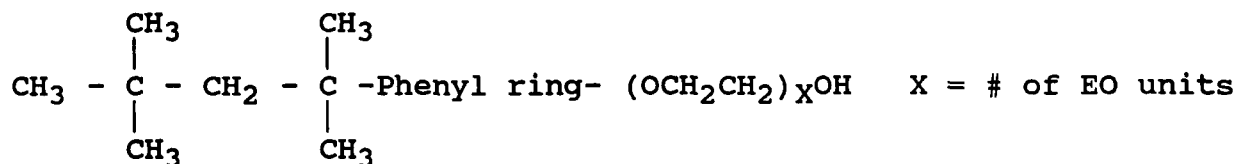

GC/MS and ¹H NMR:

Triton X-15: This Triton was found to be mostly pure by GC/MS using chemical ionization with ether (Spectrum 5). ¹H NMR showed 90% of the compound was in the monomer form ie. EO = 1 and 10% in the dimer (EO = 2).

Triton X-35: This compound was shown by GC/MS to contain some impurities (Spectrum 6). These were additional EO units probably added during the synthesis of the compound. From GC-MS the number of EO groups would be 4, 5, 6 and 3. Thus X-35 is only a minor component. ¹H NMR proved to be more difficult because the compound is a mixture.

Triton X-114: This Triton was also shown by GC/MS to be a mixture (Spectrum 7). The main constituents would be X-114 with 7-8 EO, however higher ethoxylates are present (9-10, EO) in minor quantities. Similarly, ¹H NMR proved to be difficult because the compound is a mixture.

Triton X-100: Triton X-100 was found by GC/MS to be mostly pure with 9-10 EO as the major constituents and 11 as an impurity (Spectrum 8). Again ¹H NMR proved to be difficult. Below are the GC/MS spectra for the Triton series. The ¹H NMR spectrum for X-15 is shown (Spectrum 9). The interpretation for the ¹H NMR for the other members of the Triton series was more difficult as these are mixtures and hence their spectra have been omitted.

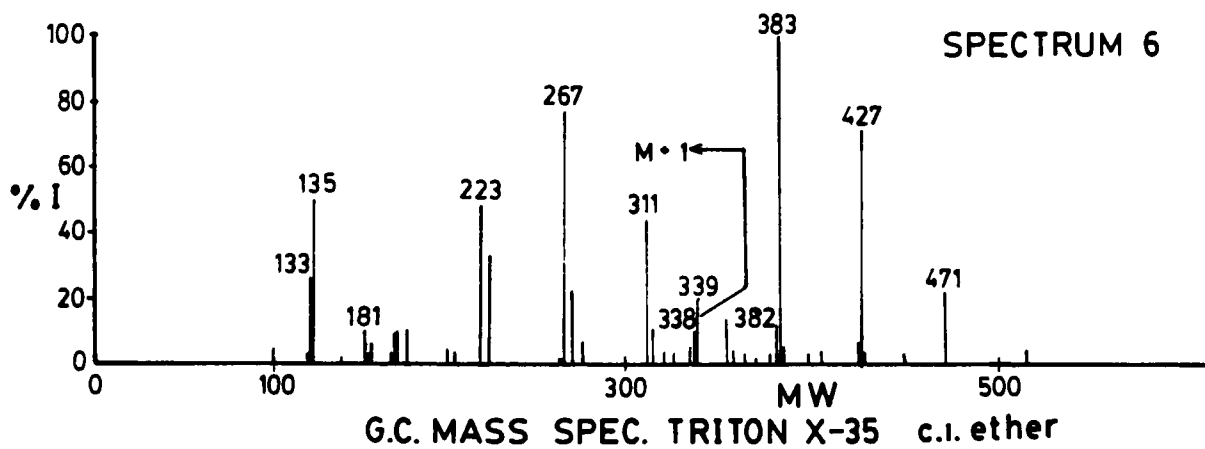
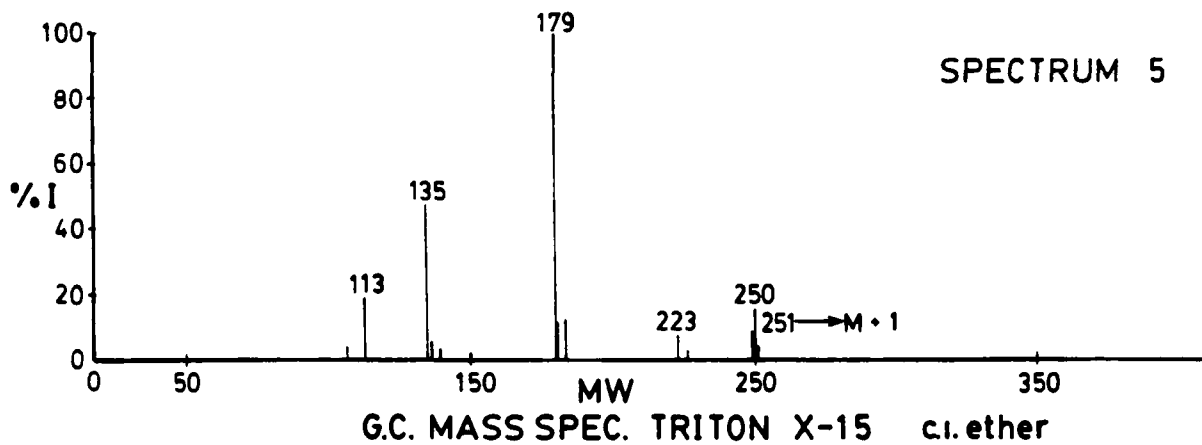

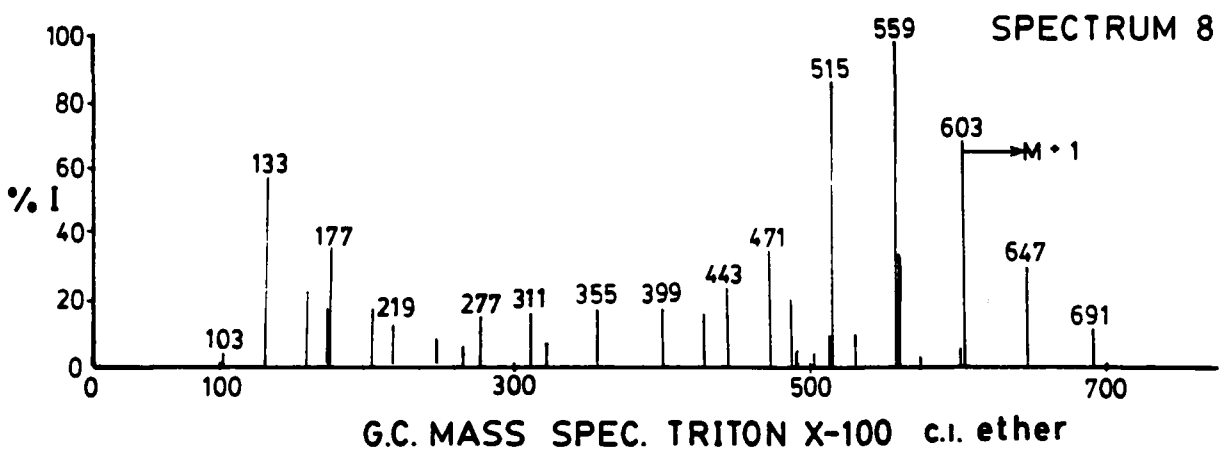
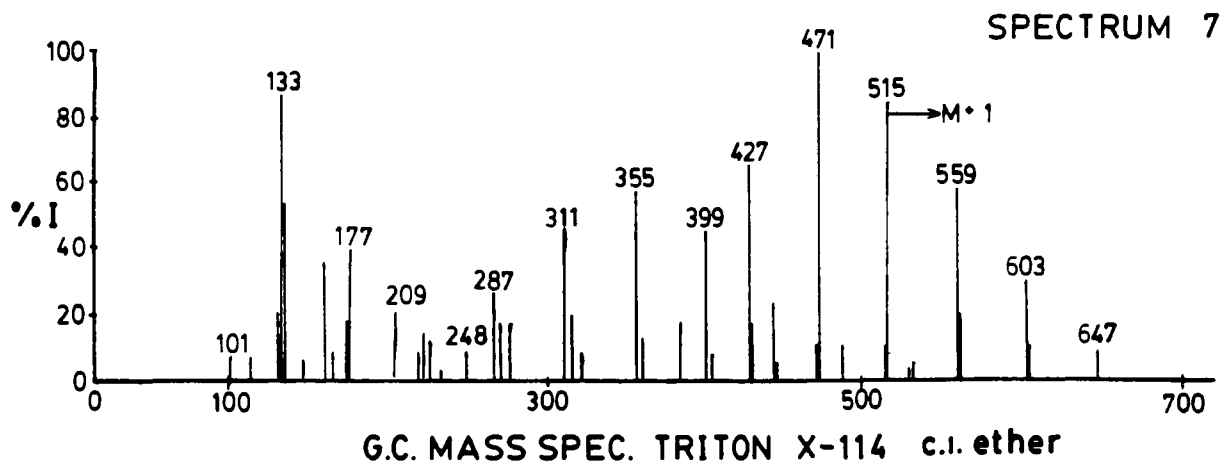

SPECTRUM 9

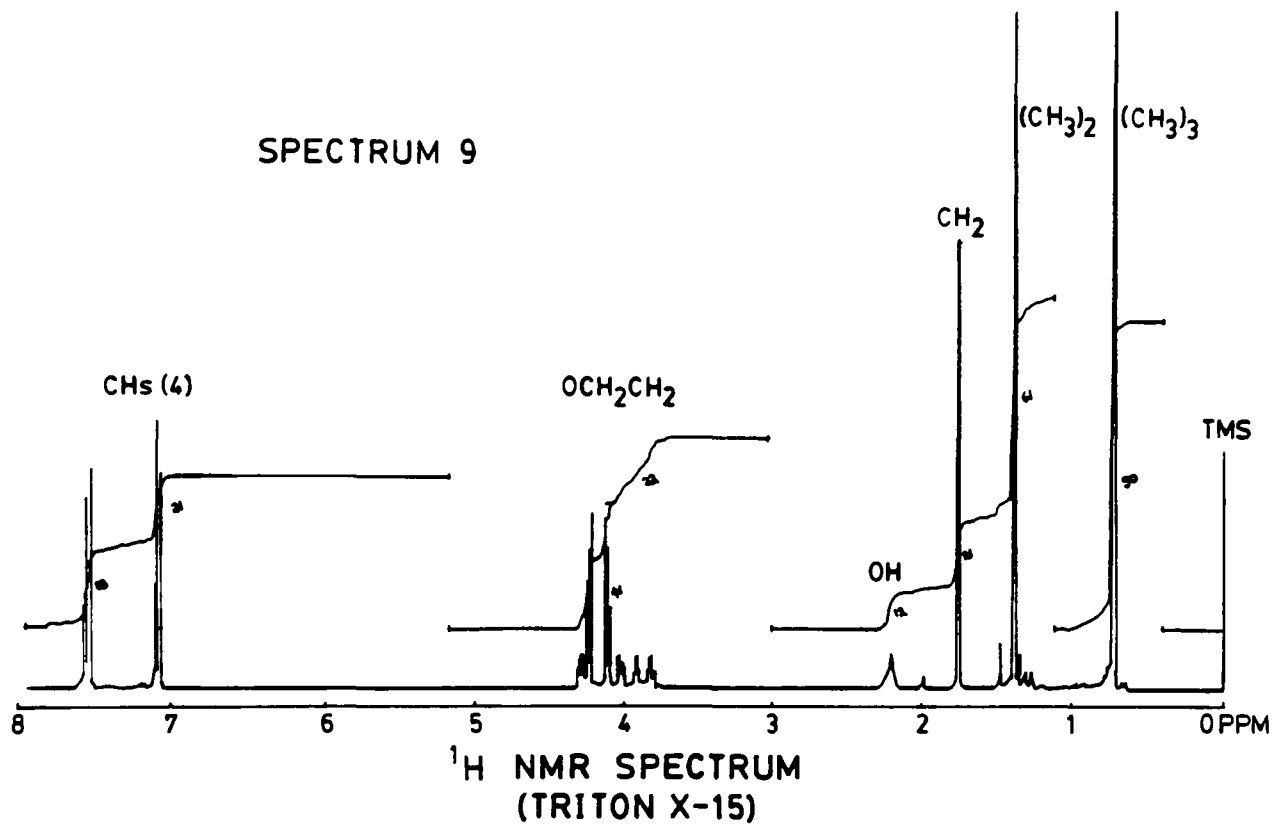

APPENDIX C: Extraction efficiencies for Dowanol

Dowanol was extracted from Bowker media (200 ml), with two 100 ml fractions of dichloromethane. Three samples injected three times into a gas chromatograph gave the following results:

	% recovery	Average	S.D.	Average (total)
1	97.3			
2	96	96.8	0.76	
3	97			
1	100			
2	96	98	2.0	97.8 ± 1.8
3	98			
1	100			
2	95.6	98.5	2.5	
3	100			

Dowanol extracted with different organic solvents, namely chloroform, ethyl acetate and hexane, gave a 90, 53, and 5% recovery respectively. It is evident then that dichloromethane is the most efficient solvent which will extract Dowanol out of the bathing media.

APPENDIX D: Triton spectra

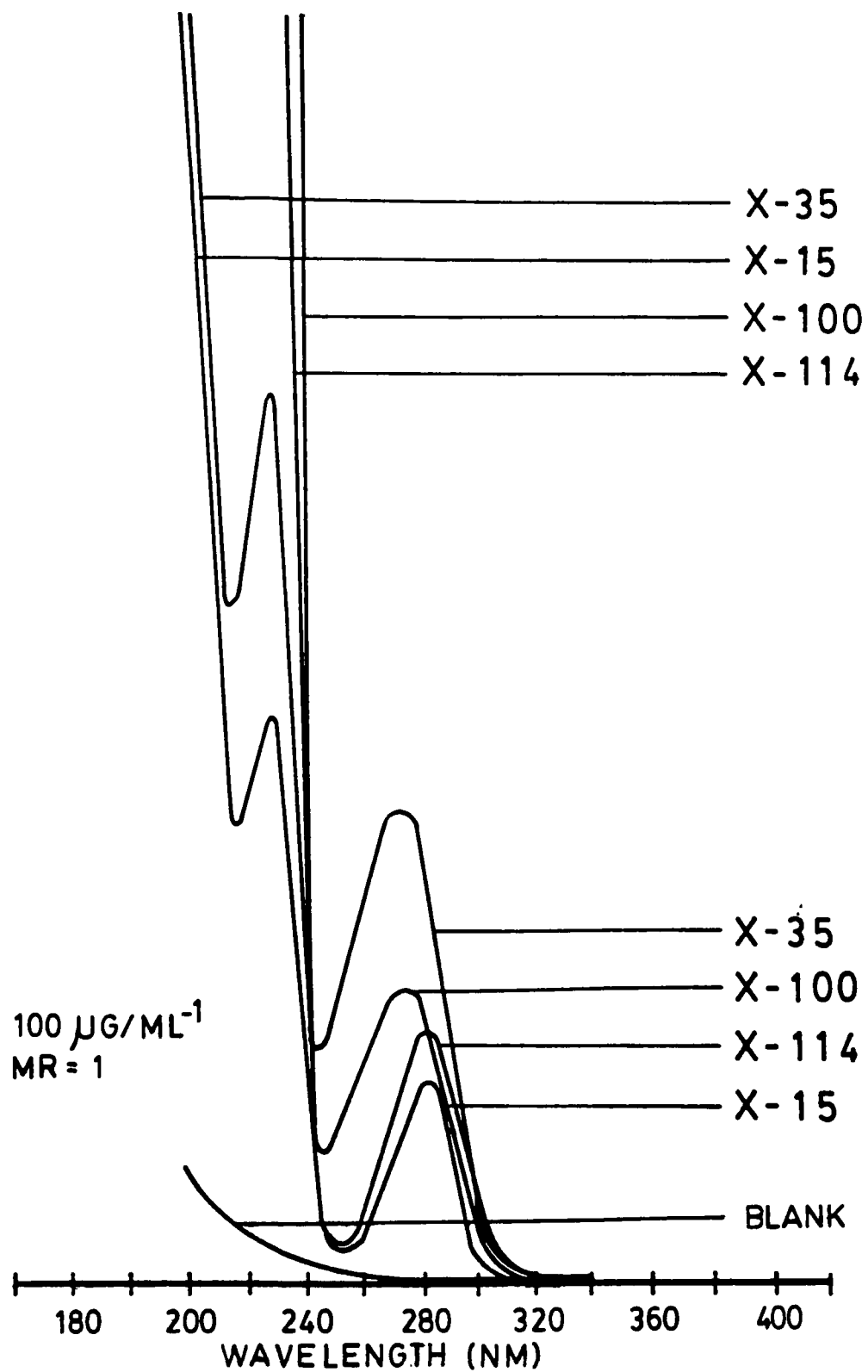

APPENDIX E: Triton incorporation in chloroplast

The Figure below shows the incorporation of Triton X-15 and X-100 in the chloroplasts of Lemna minor after their isolation. The fronds were treated with the surfactants at a concentration of 100 μM and after a two week period, their chloroplasts were isolated and the spectra of the solutions taken.

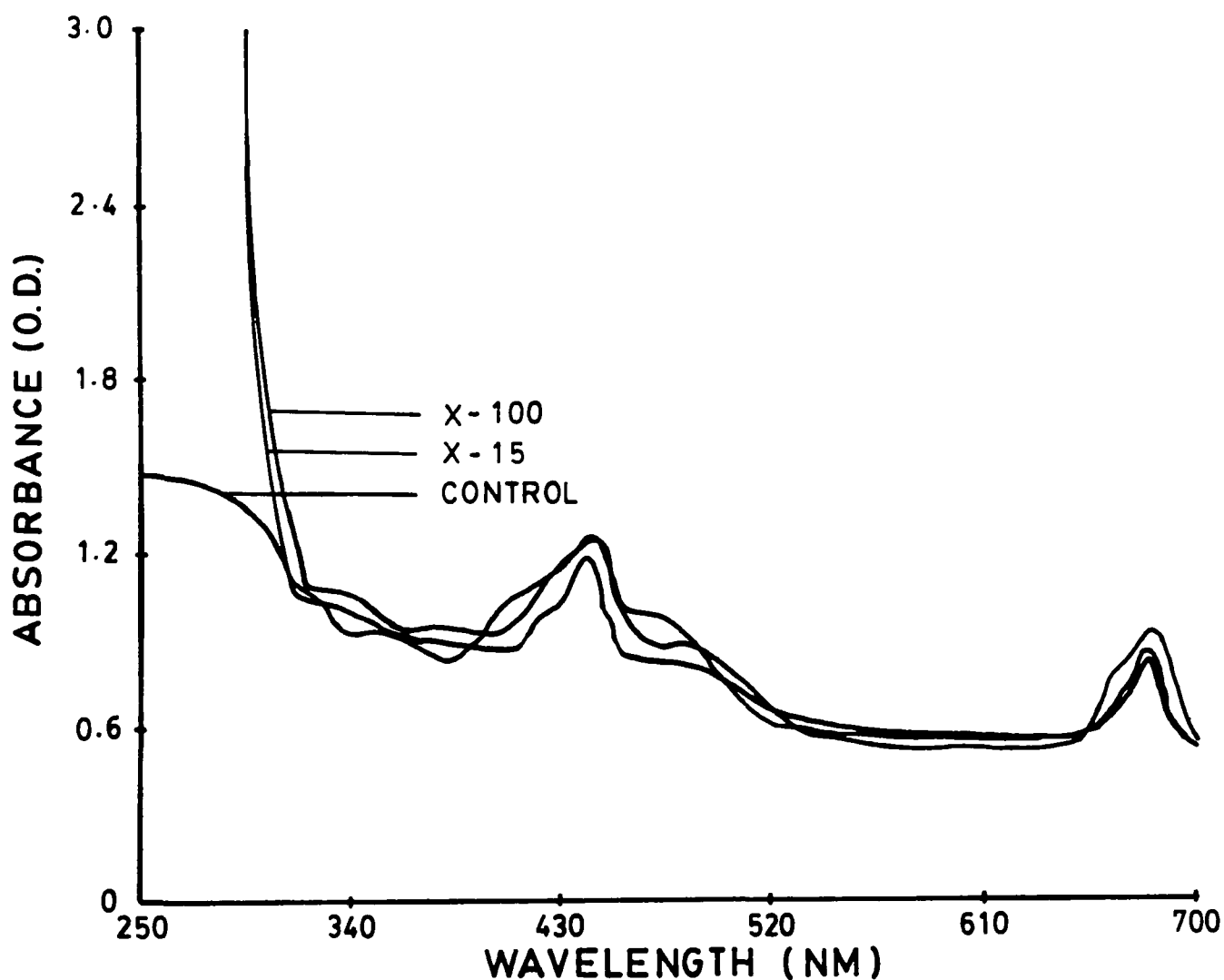

APPENDIX F: Fluorescence Transients

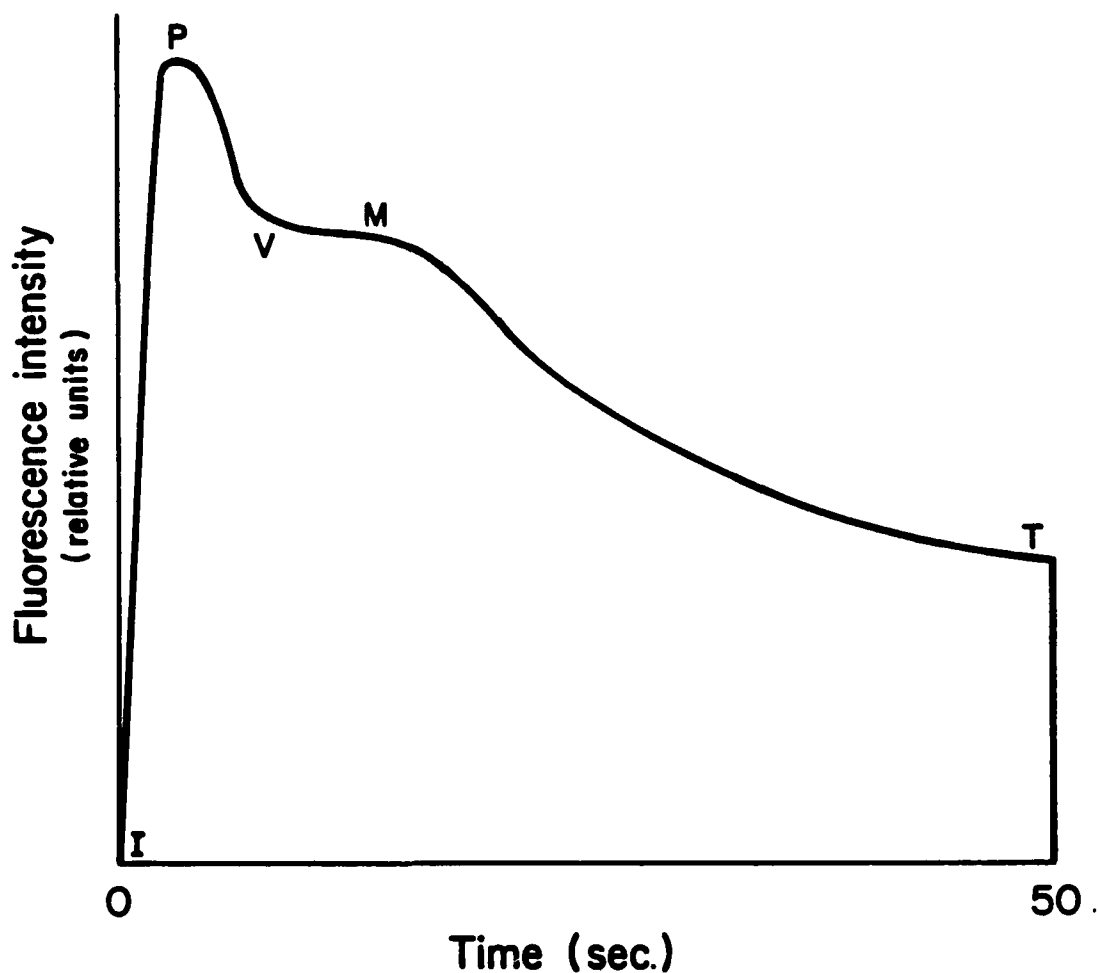

The fluorescence transients in Lemna minor, as measured with a fluorometer/chart recorder with an excitation wavelength of 670 nm and cutoff of 710 nm and an incident intensity of 10^4 ergs cm^{-2} sec^{-1} . The transients between the points I,P,V,M and T are indicative of photosynthetic partial reactions. (See: Mohanty, P., G. Papageorgiou and Govindjee. 1971. Fluorescence induction in the red alga Porphyridium cruentum. Photochem. Photobiol. 14:667-682.)

APPENDIX G: Amino acid analysis

Two ml of ninhydrin (ninhydrin monohydrate 100 mg in 100 ml deionized distilled water or 0.1% w/v) was added to 2 ml of media and the mixture heated in boiling water for 20 min, cooled and the absorbance read at 570 nm. Standards were run using different concentrations of leucine (50 mg leucine in 100 ml deionized distilled water).

Leucine concentration ($\mu\text{g ml}^{-1}$)	Abs ⁵⁷⁰
25	no color change
50	0.062
75	0.449
125	0.812
175	1.136
250	2.478 (off scale, dil. X 2)

There was no change in color in the experimental tubes. These contained the media of plants that were treated with the different Tritons at a concentration of 1, 10 and 50 $\mu\text{g ml}^{-1}$ for a period of 7 and 14 days.

REFERENCES

1. Hodgson, R.H. and F. Maryland. 1982. In: Adjuvants for Herbicides. Edited by: Hodgson, R.H. Weed Science Society of America. Champaign, IL, 144 pages.
2. Somers, E. 1985. Personal communication. Health and Welfare Canada, Ottawa, Ontario, Canada.
3. Ernst, R., J. Arditti and P.L. Healey. 1971. Biological effects of surfactants. I. Influence on the growth of orchid seedlings. *New Phytol.* 70:547-475.
4. Abel, P.D. 1974. Toxicity of synthetic detergents to fish and aquatic invertebrates. *J. Fish Biol.* 6:279-298.
5. Berry, W.O. and J.D. Brammer. 1977. Toxicity of water-soluble gasoline fractions to fourth-instar larvae of the mosquito Aedes aegypti L. *Environ. Pollut.* 13:229-234.
6. Bode, H., R. Ernst and J. Arditti. 1978. Biological effects of surfactants III. Hydra as a highly sensitive assay animal. *Environ. Pollut.* 17:175-185.
7. Devlin, R.M., M.J. Kigiel and A.S. Kostusiak. 1979. Use of organic solvents in the screening of herbicides and growth regulators. *Proc Northeastern Weed Sci. Soc.* 33:324-327.
8. William, K.W. Li and J.C. Goldman. 1981. Problems in estimating growth rates of marine phytoplankton from short-term ¹⁴C assays. *Micarb. Ecol.* 7:113-121.
9. Pest Control Products Act. 1982. Supply and Services Canada, Cat. No. YX 75-P-10-1982.
10. Swisher, E.M. 1982. Adjuvant regulation and registration. In: Adjuvants for Herbicides. Edited by: Hodgson, R.H. Weed Science Society of America. Champaign, IL, pp. 119-133.
11. Sundaram, A., L. Kotlyar and B.D. Sparks. 1987. Influence of surfactants and polymeric adjuvants on physicochemical properties, droplet size spectra and deposition of fenitrothion and Bacillus thuringiensis formulations under laboratory conditions. *J. Environ. Sci. Health.* B22:691-720.
12. Hillman, W.S. 1961. The Lemnaceae or Duckweeds. A review of the descriptive and experimental literature. *Bot. Rev.* 27:221-318.

13. Datko, A.H., H.S. Mudd, and J. Giovanelly. 1980. Lemna paucicostata Elgelm. 6746. Plant physiol. 65:913-923.
14. Hillman, W.S. and D.D. Culley, Jr. 1978. The use of duckweed. Am. Scientist. 66:442-451.
15. De Lange L. 1975. Gibbosity in the complex Lemna gibba/Lemna minor: Literature survey and ecological aspects. Aquat. Bot. 1:327-332.
16. Nasu, Y. and Kugimoto. 1981. Lemna (duckweed) as an indicator of water pollution. I. The sensitivity of Lemna paucicostata to heavy metals. Arch. Environ. Contam. Toxicol. 10:159-169.
17. Wang, W. 1987. Toxicity of nickel to common duckweed (Lemna minor). Environ. Toxicol. Chem. 6:961-967.
18. Strother, S. 1981. Toxic effects of exogenous sorbose on Lemna minor and some other angiosperms. Ann. Bot. 47:531-533.
19. Chui Lien, B. J.R.L. Walker and J.A. Peters. 1980. The effect of fluoroacetate ("compound 1080") and fluoride upon duckweeds. New Zealand J. Sci. 23:179-183.
20. Gower, R.A. and H.B. Posner. 1979. Effects of light and 3-(3,4-dichlorophenyl)-1,1-dimethylurea on levels of ATP in Lemna paucicostata 6746 and a photosynthetic mutant with abnormal flowering responses. Plant Physiol. 63:548-551.
21. O'Brien, M.C. and G.N. Prendeville. 1979. Effect of herbicides on cell membrane permeability in Lemna minor. Weed Res. 19:331-334.
22. Mortimer, D. 1985. Personal communication. National Research Council Canada, Ottawa, Ontario, Canada.
23. Porath, D. B. Hefher and A. Koton. 1979. Duckweed as an aquatic crop: Evaluation of clones for aquaculture. Aquat. Bot. 7:273-278.
24. Culley, D.D., Jr. and E.A. Epps. 1973. Use of duckweed for waste treatment and animal feed. J. Water Pollut. Control Fed. 45:337-347.
25. Loomis, T.A. 1978. Essentials of toxicology. Lea and Febiger, Philadelphia. 245 pages.
26. J.W. Van Valkenburg. 1982. Terminology, classification and chemistry. In: Adjuvants for Herbicides. Edited by: Hodgson, R.H. Weed Science Society of America. Champaign, IL, pp. 1-9.

27. Wolf, E., Schulze, F.W., Petrick, H.J., Cammenga, H.K. and G.T. Barnes. 1979. Der Einfluss technischer Tenside auf den Masse und Energietransport bei der Wasserverdunstung. Tenside Detergents. 16:57-64.
28. Parr, J.F. and A.G. Norman. 1965. Considerations in the use of surfactants in plant systems: A review. Botan. Gaz. 126:86-96.
29. Kenaga, E.E. 1972. Guidelines for environmental study of pesticides. Determination and bioconcentration potential. Res. Rev. 44:73.
30. Koch, R. 1983. Molecular connectivity index for assessing ecotoxicological behaviour of organic compounds. Toxicol. Environ. Chem. 6:87-96.
31. Norris, R.F. 1982. Action and fate of adjuvants in plants. In: Adjuvants for Herbicides. Edited by: Hodgson, R.H. Weed Science Society of America. Champaign IL, pp. 68-79.
32. Helenius, A. and K. Simons. 1975. Solubilization of membranes by detergents. Biochim. Biophys. Acta. 415:29-79.
33. Griffin, W.C. 1954. Calculation of HLB of non-ionic surfactants. J. Soc. Cosmetic Chemists. 5:249-258.
34. McWhorter, C.G. 1985. The physiological effects of adjuvants on plants. In: Weed physiology: Herbicide physiology. Edited by: Duke, S.O. CRC Press, Boca Raton, Fla. vol. II. pp. 141-158.
35. Chiou, C.T., V.H. Freed, D.W. Schmedding and R.L. Kohnert. 1977. Partition coefficient and bioaccumulation of selected organic chemicals. Environ. Sci. Tech. 11:475-478.
36. Crum Brown, A. and T.R. Fraser. 1868-69. On the connection between chemical constitution and physiological action I. On the physiological action of the salts of the ammonium bases, derived from strychnia, brucia, thebaia, codeia, morphia and nicotia. Trans. Roy. Soc. Edinburgh. 25:151-203.
37. Zitko, V. and D.W. McLeese. 1980. Evaluation of hazards of pesticide uses in forest spraying to the aquatic environment. Canadian Technical Report of Fisheries and Aquatic Science No. 985. 21 pages.
38. Neely, W.B., D.R. Branson and G.E. Blau. 1974. Partition coefficient to measure bioconcentration potential of organic chemicals. Fish Environ. Sci. Tech. 8:1113-1115.

39. Ellgehausen, H., J.H. Guth and H.O. Esser. 1980. Factors determining the bioaccumulation potential of pesticides in the individual compartments of aquatic food chains. *Ecotox. Environ. Safety*. 4:134-157.
40. Lockhart, W.L., B.N. Billeck, B.G.E. De March, and D.C.G. Muir. 1983. Uptake and toxicity of organic compounds studies with an aquatic macrophyte (Lemna minor). *Aquatic Toxicology*, Sixth Symposium. pp. 460-468.
41. Gremlyn, R. 1978. Pesticides, preparation and mode of action. Wiley and Sons Ltd., N. York. p. 15.
42. DOWANOL DPM use in cosmetic formulations. 1980. Technical Data Report. Form No 1 110 37680 and 37480. Dow Chemical USA. Midland, MI, 7 and 4 pages.
43. Moody, R. 1982. Algicidal activity of formulated fenitrothion. The effect of cosolvent, Aerotex 3470 on unicellular algae. Ph.D. thesis. University of Ottawa, Canada.
44. Weinberger, P. and R. Greenhalgh. 1984. Ecotoxicity of adjuvants used in aerial spraying. In: Chemical and biological controls in forestry. Edited by: Garner, W.Y. and J. Harvey Jr. Amer. Chem. Soc., Washington D.C. pp. 351-363.
45. Spitzer, W.O. 1982. First report: New Brunswick Task Force on the environment and Reye's syndrome. Spitzer, W.O. National Health Scientist, Director of the Division of Clinical Epidemiology, McGill University, Montreal, Quebec, H3G-1A4.
46. Sundaram, A. 1983. Development, physicochemical properties and spray behavioral characteristics of fenitrothion and aminocarb emulsion formulations. Canadian Forestry Service, Sudbury, Ontario, File Report No. 42 CFS. Action Plan.
47. Edwards, J.C. 1982. Update on the New Brunswick action program. Forest Pest Management Institute Newsletter. 1:1-6.
48. Singh, M. and J.R. Orsenigo. 1984. Phytotoxicity of non-ionic surfactants to sugarcane. *Bull. Environ. Contam. Toxicol.* 32:119-124.
49. Nethery, A.A. and G.B. Wilson. 1967. Classification of the cytological activity of phenols and aromatic organophosphates. *Cytologia*. 31:270-275.
50. Parr, J.F. and A.G. Norman. 1964. Effects of non-ionic surfactants on root growth and cation uptake. *Plant Physiol.* 39:502-507.

51. Vernon, L.P. and E.R. Shaw. 1965. Photochemical activities of spinach chloroplasts following treatment with the detergent Triton X-100. *Plant physiol.* 40:1269-1277.
52. Porstmann, B., T. Porstmann, D. Gaede, E. Nugel and E. Egger. 1981. Temperature dependent rise in activity of horseradish peroxidase caused by non-ionic detergents and its use in enzyme-immunoassay. *Clin. Chim. Acta.* 109:175-181.
53. Stowe, B.B. 1960. Growth promotion in pea stem sections. *Plant Physiol.* 35:262-269.
54. Haapala, E. 1973. The growth of the primary roots and root hairs of Sinapis alba and Lepidium sativus in Triton X-100. *Physiol. Plant.* 28:56-60.
55. Markwell J.P. and P. Thornber. 1982. Treatment of the thylakoid membrane with surfactants. *Plant Physiol.* 70:633-636.
56. Shelton, K.R. 1976. Selective effects of nonionic detergent and salt solutions in dissolving nuclear envelope protein. *Biochim. Biophys. Acta.* 455:973-982.
57. Nethery, A.A. 1967. Inhibition of mitosis by surfactants. *Cytologia.* 32:321-327.
58. Towne, C.A., P.G. Bartels and J.L. Hilton. 1978. Interaction of surfactant and herbicide treatments on single cells of leaves. *Weed Sci.* 26:182-188.
59. Horowitz, M. and A. Givelberg. 1979. Toxic effects of surfactants applied to plant roots. *Pestic. Sci.* 10:547-557.
60. Hutchinson, T.C. J.A. Hellebust, D. Mackay, D. Tam and P. Kauss. 1979. Relationship of hydrocarbon solubility to toxicity in algae and cellular membrane effects. *Oil Spill Conference, Spill Behavior and Effects, API/EPA.* pp. 541-547.
61. Schmid, O.F. and H. Mann. 1961. Action of detergent (dodecyl benzene sulphonate) on the gills of trout. *Nature.* 192:675.
62. Haapala, E. 1970. The effect of a non-ionic detergent on some plant cells. *Physiol. Plant.* 23:187-201.
63. St. John, J.B., P.G. Bartels and J.L. Hilton. 1974. Surfactant effects on isolated plant cells. *Weed Sci.* 22:233-237.
64. Blinkhorn, C and M.N. Jones. 1973. Effect of surfactant structure on ribonuclease A-surfactant interactions. *Biochem. J.* 135:547-549.

65. Clapshaw, P.A. and W. Seifert. 1980. Effects of detergents, proteins and lipids on 2':3'-cyclic nucleotide 3'-phosphodiesterase activity. *J. Neurochem.* 35:164-169.
66. Mazliak, P. and A.M. Decotte. 1976. Effects of four detergents on the oxidative and phosphorylating capacities of potato mitochondria. *J. Expt. Bot.* 27:769-777.
67. Sauer, K. and R.B. Park. 1964. Molecular orientation in quantasomes II. Absorption spectra, hill activity and fluorescence yields. *Biochim. Biophys. Acta.* 79:476-489.
68. Deamer, D.W. and A. Crofts. 1967. Action of Triton X-100 on chloroplast membranes. *J. Cell Biol.* 33:395-410.
69. Newman, J. and A. Jagendorf. 1965. Uncoupling photophosphorylation by detergents. *Biochim. Biophys. Acta.* 109:382-389.
70. Johnstone, D.R. 1973. Spreading and retention of agricultural sprays on foliage. In: Pesticide formulations. Edited by: Van Valkenburg, W. Marcel Dekker, Inc., N. York. pp. 343-386.
71. Hull, H.M., D.G. Davis and G.E. Stozenberg. 1982. Action of adjuvants on plant surfaces. In: Adjuvants for herbicides. Edited by: Hodgson, R.H. Weed Science Society of America, Champaign IL. pp. 27-67.
72. DeRuiter, H., J.R. Hoekstra and A.J.M. Uffing. 1987. The influence of different adjuvants on the phytotoxicity of glyphosate and fluzafop-p-butyl. *Med. Fac. Landbouww. Rijksuniv. Gent.* 52:1217-1224.
73. Takeno, T. and C.L. Foy. 1974. Effect of polysorbate surfactants on the ultrastructure of leaf surfaces. *Weed Sci. Soc. Amer. Abstr.* p. 92.
74. Shafer, W.E. and M.J. Bukovac. 1987. Studies on octylphenoxy surfactants. III Sorption of Triton X-100 by isolated tomato fruit cuticles. *Plant Physiol.* 85:965-970.
75. Smith, L.W., C.L. Foy and D.E. Bayer. 1966. Structure-activity relationships of alkylphenol ethylene oxide ether non-ionic surfactants and three water-soluble herbicides. *Weed Res.* 6:233-242.
76. Schlieper, P. and E. DeRobertis. 1977. Triton X-100 as a channel-forming substance in artificial lipid bilayer membranes. *Arch. Biochem. Biophys.* 184:204-208.

77. **Banghan, J.A. and E.J.A. Lea.** 1978. The interaction of detergents with bilayer lipid membranes. *Biochim. Biophys. Acta* 511:388-396.
78. **Simone, C.B. and P. Henkart.** 1980. Permeability changes in erythrocyte ghost targets by antibody dependent cytotoxic effector cell: Evidence for membrane pores. *J. Immunol.* 124:954-963.
79. **Aloia, R.C.** 1983. Membrane fluidity in biology. General principles. Vol 1. Academic Press, N. York.
80. **Haynes, D.H. and H. Staerk.** 1974. 1-anilino-8-naphthalenesulfonate: A fluorescent probe of membrane surface structure, composition and mobility. *J. Membrane Biol.* 17:313-340.
81. **Gulik-Krzywicki, T., E. Shechter, M. Iwatsubo, J.L. Ranck and V. Luzzati.** 1970. *Biochim. Biophys. Acta.* 219:1-10.
82. **Nyberg, H. and K. Koskimies-Soininen.** 1984. The glycolipid fatty acids of Porphyridium purpureum cultured in the presence of detergents. *Phytochemistry.* 23:751-757.
83. **Nyberg, H.** 1985. Physiological effects of four detergents on the algae Nitzschia actinastroides and Porphyridium purpureum. Helsingin Yliopiston Kasvitieteen Laitoksen Julkaisuja. Publications from the Department of Botany, University of Helsinki, Helsinki. 77 pages.
84. **Singer, S.J. and G.L. Nicholson.** 1972. The fluid mosaic model of the structure of cell membranes. *Science.* 175:720-731.
85. **Seeman, P.** 1972. The membrane actions of anaesthetics and tranquilizers. *Pharmacol. Rev.* 24:583-655.
86. **Grenier, G., J-P. Marier et G. Beaumont.** 1979. Effets physiologiques de l'atrazine à doses sublétale sur Lemna minor L. IV. Influence sur la composition lipidique. *Can. J. Bot.* 57:1015-1020.
87. **Grenier, G., J-P. Marier et G. Beaumont.** 1982. Effets physiologiques de l'atrazine à doses sublétales sur Lemna minor. VI. Influence sur les classes importantes de phospholipides. *Physiol. Vég.* 20:179-185.
88. **Trémolière, A.** 1970. Les lipides des tissus photosynthétiques. *Ann. Biol.* 9:113-156.
89. **Kates, M. and M.O. Marshall.** 1975. In: Recent advances in chemistry and biochemistry of plant lipids. Edited by: Galliard, T. and I. Mercer. Academic Press, N. York. Chpt. 5.

90. Stubbs, C.D., T. Kouyama, K. Kinoshita Jr. and A. Ikegami. 1981. Effects of double bonds on the dynamic properties of the hydrocarbon region of lecithin bilayers. *Biochemistry*. 20:4257-4262.
91. Lenaz, G. and G. Parenti Castelli. 1983. Membrane fluidity: Molecular basis and physiological significance. In: Membrane fluidity in biology. General principles. Edited by: Aloia, R.C. Vol 1-2. Academic Press, N. York. Chpt. 6. pp. 93-136.
92. Aloia, R.C. 1983. Membrane fluidity in biology. General principles. Vol 2. Academic Press, N. York.
93. Lyons, J.M., J.K. Raison and P.L. Steponkus. 1979. The plant membrane in response to low temperature: An overview. In: Low temperature stress in crop plants, the role of the membrane. Edited by: Lyons, J.M., D. Graham and J.K. Raison. Academic Press, N. York. pp. 1-24.
94. Boggs, J.M. 1983. The hydrophobic and electrostatic effects of proteins on lipid fluidity and organization. In: Membrane fluidity in biology. General principles. Edited by: Aloia, R.C. Academic Press, N. York. p. 126.
95. Shinitzky, M. and I. Yuli. 1982. Lipid fluidity at the submacroscopic level: Determination by fluorescence polarization. *Chem. Phys. Lipids*. 30:261-26.
96. Ottewill, R.H. and T. Walker. 1968. The influence of nonionic surface active agents on the stability of poly-styrene latex dispersions. *Kolloid-ZZ Polymere*. 227:108-115.
97. Garret, Diane E. 1968. Analytical methods for atomic absorption spectrophotometry. Atomic Applications Laboratory, Perkin-Elmer Corporation, Norwalk, Connecticut. 60 pages.
98. Landlot, E. 1975. Morphological differentiation and geographical distribution of the Lemna gibba-Lemna minor group. *Aquat. Bot.* 1:345-363.
99. Bowker, D.W., A.N. Duffield and P. Denny. 1980. Methods for the isolation, sterilization and cultivation of Lemnaceae. *Freshwater Biol.* 10:385-388.
100. Caux, P-Y., P. Weinberger and D.B. Carlisle. 1986. Dowanol, an environmentally safe adjuvant. *Env. Tox. Chem.* 5:1047-1054.
101. Arnon, D.I. 1949. Copper enzymes in isolated chloroplasts. Polyphenoloxidase in Beta vulgaris. *Plant physiol.* 24:1-15.

102. Vernon, L.P. 1960. Spectrophotometric determination of chlorophylls and pheophytins in plant extracts. *Anal. Chem.* 32:1140-1150.
103. Gower, R.A. 1983. Solubility of hydrophobic compounds. *Bull. Environ. Contam. Toxicol.* 32:53-58.
104. Patterson, J.W., P.L. Brezonik and D. Putman. 1970. Measurement and significance of adenosine triphosphate in activated sludge. *Current Res.* 4:569-575.
105. Moody, R., P. Weinberger, and R. Greenhalgh. 1983. Algal fluorometric determination of the potential phytotoxicity of environmental pollutants. In: Aquatic Toxicology. Edited by: Nriagu, J.O. John Wiley and Sons Inc. New York. pp. 503-512.
106. Bligh, E.G. and Dyer, W.J. 1959. A rapid method of total lipid extraction and purification. *Can. J. Biochem. Physiol.* 37:911-917.
107. Jones, R.A.D. 1969. Studies on metabolic changes accompanying imbibition and vernalization of a spring and a winter wheat. PhD thesis, University of Ottawa, Ottawa, Ontario. p. 20.
108. Kates, M. 1970. In: Techniques of lipidology. Edited by: Work, T.S. and E. Work. Am. Elsevier Pu. Co. N. York. 438 pages.
109. Metcalfe, L.D., A.A. Schmitz and J.R. Pelka. 1966. Rapid preparation of fatty acid esters from lipids for gas chromatographic analysis. *Analytical Chemistry.* 38:514-515.
110. Thomson, W.W. and C.H. Moeller. 1983. Effects of Tween-20, polyoxyethylene sorbitan monolaurate on the ultrastructure and organization of chloroplast membranes. *Protoplasma.* 114:174-178.
111. Martin, C.E. and G.A. Thompson. 1978. Use of fluorescence polarization to monitor intracellular membrane changes during temperature acclimation. Correlation with lipid compositional and ultrastructural changes. *Biochemistry.* 17:3581-3586.
112. Bartlett, M.S. 1937. Some examples of statistical methods of research in agriculture and applied biology. *J. Roy. Statist. Soc. Suppl.* 4:137-170.
113. Tukey, J.W. 1949. Comparing individual means in the analysis of variance. *Biometrics.* 5:99-104.
114. Schreiber, U., W. Vidaver, V.C. Runeckle and P. Rosen. 1978. Chlorophyll fluorescence assay for ozone injury in intact plants. *Plant Physiol.* 61:80-84.

115. Ahrens, W.H., C.J. Arntzen and E.W. Stoller. 1981. Chlorophyll fluorescence assay for the determination of triazine resistance. *Weed Sci.* 29:316-322.
116. Kaustsky, H. and A. Hirsch. 1931. Neve Versuche zur Kohlensaure Assimilation. *Naturwissenschaften.* 19:964.
117. Govindjee and C. Papageorgiou. 1971. Chlorophyll fluorescence and photosynthesis: Fluorescence transients. In: Photobiology. Edited by: Giese, A.C. Academic Press, N. York. pp. 1-46.
118. Schreiber, U., L. Groberman and W. Vidaver. 1975. Portable solid-state fluorometer for the measurement of chlorophyll fluorescence induction in plants. *Rev. Sci. Instrum.* 46:538-542.
119. Moody, R. 1984. Personal communication. Health and Welfare Canada, Ottawa, Ontario, Canada.
120. Smyth, H.F. 1967. Sufficient challenge. *Food Cosmetic Toxicol.* 5:51-58.
121. Stebbing, A.R.D. 1982. Homesis - The stimulation of growth by low levels of inhibitors. *Sci. Total Environ.* 22:213-234.
122. Sandmann, G. and P. Boger. 1982. Mode of action of herbicidal bleaching. In: Biochemical responses induced by herbicides. Edited by: Moreland, D., J.B. St.-John and F.D. Hess. American Chemical Society, Washington, DC. pp. 111-129.
123. Weinberger, P. and R. Greenhalgh. 1984. Some adjuvant effects on the fate of fenitrothion and aminocarb. *Environ. Toxicol. Chem.* 3:325-334.
124. Iyengar, S. 1983. The effects of Matacil 1.8D and its constituents Aminocarb, Nonylphenol and diluent oil, on Lemna minor L. a non target species. M.Sc. thesis, Department of Biology, Faculty of Science and Engineering, University of Ottawa, Ottawa, Canada.
125. Subbaraj, G. and S. Bose. 1984. Recovery from methyl parathion-induced damage of the photosynthetic apparatus in Chlorella protothecoides. *Bull. Environ. Contam. Toxicol.* 32:102-108.
126. McLeese, D.W., V. Zitko, C.D. Metcalf and D.B. Sergeant. 1980. Lethality of Aminocarb and the components of the Aminocarb formulation to juvenile Atlantic salmon, marine invertebrates and a freshwater clam. *Chemosphere.* 9:79-82.

127. Korte, F., D. Freitag, H. Geyer, W. Klein, A.G. Krause and E. Lahaniatis. 1978. Ecotoxicology profile analysis. *Chemosphere*. 11:475-478.
128. Kenaga, E.E. and C.A.I. Goring. 1980. Relationship between water solubility, soil absorption, octanol water partitioning, and concentration of chemicals in biota. In: *Aquatic Toxicology*. Edited by: Eaton, J.G., P.R. Parish and A.C. Hendricks. STP 707. American Society for Testing and Materials, Philadelphia, PA, pp. 78-115.
129. Weinberger, P. and M. Rea. 1980. Nonylphenol: A perturbant additive to an aquatic ecosystem. Proceedings of the 7th Annual Toxicology Workshop, Montreal, Quebec, Canada. pp. 370-381.
130. Ernst, R., E.A. Ball and J. Arditti. 1982. Biological effects of surfactants. V. Growth and anthocyanin production by callus cultures of Dimorphotheca. *Amer. J. Bot.* 69:1340-1345.
131. Nelson, P.V. and H.H. Garlich. 1969. Relationship of chemical classification and hydrophile-lipophile balance of surfactants to enhancement of foliar uptake of iron. *J. Agr. Food Chem.* 17:148-152.
132. Davis, D.G., R.L. Stolzenberg and G.E. Stolzenberg. 1982. Phototoxicity of selected non-ionic surfactants to soybean, Glycine max cell suspensions. *Environ. Pollut.* 27:197-206.
133. Bourget, S.J. and E.V. Parups. 1963. Growth of tobacco and soil-moisture evaporation as influenced by long-chain fatty alcohols in the soil. *Soil Sci.* 95:82-85.
134. O'Sullivan, P.A., J.T. Donovan and W.M. Hamman. 1981. Influence of non-ionic surfactants, ammonium sulphate, water quality and spray volume on the phytotoxicity of glyphosate. *Can. J. Plant Sci.* 61:391-400.
135. Rohm and Haas Technical Reports on Octyl and Nonyl Triton Series of Non-ionic Surface Active Agents. 1982. Rohm and Haas Chemical Co. Philadelphia, USA.
136. Beauchamp, E.G. 1972. Manganese and zinc absorption with octylphenoxyethanol surfactants by soybean leaf tissues. *Can. J. Bot.* 51:613-620.
137. Hull, H.M. 1970. Leaf structure and absorption. In: *Residues of pesticides and other foreign chemicals in foods and feeds*. Edited by: Gunther, F.A. and J.D. Gunther, Springer-Verlag, N. York. Vol. 31. p. 91.

138. Sirois, D.L. 1967. Toxicity of surfactant-herbicide combinations to Lemna minor L. Ph.D. Diss., Iowa State Univ. Sci. Technol. 97 pages.
139. Buchanan, G.A. 1965. Patterns of surfactant toxicity to plant tissues. Ph.D. Thesis, Iowa State University (LC Card No. Mic. 65-7599); available from University Microfilms, Ann Arbor, Mich.
140. Hargreaves, J.A. 1981. Accumulation of phytoalexins in cotyledons of French bean (Phaseolus vulgaris L.) following treatment with Triton (T-octylphenol polyethoxyethanol) surfactants. *New Phytol.* 87:733-741.
141. Ukeles, R. 1965. Inhibition of unicellular algae by synthetic surface-active agents. *J. Phycol.* 1:102-110.
142. Leo, A.J. 1976. Symposium on nonbiological transport and transformation, National Bureau of Standards, Gaithersburg, MD. USA.
143. Hawker, D.W. and D.W. Connell. 1985. Relationships between partition coefficient, uptake rate constant, clearance rate constant and time to equilibrium for bioaccumulation. *Chemosphere.* 14:1205-1219.
144. Smith, J.H., W.R., Mabey, N. Bohonos, B.R. Holt, S.S. Lee, T.-W. Chou, B.C. Bomberber and T. Mill. 1977. Environmental pathways of selected chemicals in freshwater systems. Part I: Background and experimental procedures. EPA-600/7-77-113.
145. Mackay, D. 1979. Finding fugacity feasible. *Environ. Sci. Technol.* 13:1218-1223.
146. Lipnick, R.L. 1985. A perspective on quantitative structure-activity relationships in ecotoxicology. *Environ. Toxicol. Chem.* 4:255-257.
147. Wold, S., W.J. Dunn and Hellberg, S. 1985. Toxicity modeling and prediction with pattern recognition. *Environ. Health Perspect.* 61:257-268.
148. Dearden, J.C. 1985. Partitioning and lipophilicity in quantitative structure-activity relationships. *Environ. Health Perspect.* 61:203-228.
149. Lien, E.J. 1985. Molecular structures and different modes of exposure affecting transport and toxicities of chemicals: QSAR analyses. *Environ. Toxicol. Chem.* 4:259-271.

150. Hermens, J., H. Könemann, P. Leeuwangh and Aalt Musch. 1985. Quantitative structure-activity relationships in aquatic toxicity studies of chemicals and complex mixtures of chemicals. *Environ. Toxicol. Chem.* 4:273-279.
151. Klopman, G. 1985. Predicting toxicity through a computer automated structure evaluation program. *Environ. Health Perspect.* 61:269-274.
152. Parr, J.F. 1982. Toxicology of adjuvants. In: Adjuvants for herbicides. Edited by: Hodgson, R.H. Weed Science Society of America, Champaign IL. pp. 93-114.
153. Douce, R. and Joyard, J. 1980. Plant galactolipids. In: The biochemistry of plants, vol 4. Edited by: Stumpf, P.K. Academic Press, London, ISBN 0-12-675404-7.
154. Sumida, S. and U. Minoru. 1973. Studies of pesticide effects on Chlorella metabolism I. Effect of herbicides on complex lipid biosynthesis. *Plant Cell Physiol.* 14:781-785.
155. Cullis, P.R. and B. De Kruijff. 1978. Polymorphic phase behaviour of lipid mixtures as detected by ^{31}P NMR. Evidence that cholesterol may destabilize bilayer structure in membrane systems containing phosphatidylethanolamine. *Biochim. Biophys. Acta.* 507:207-218.
156. Cullis, P.R. and B. De Kruijff. 1978. Effects of fusogenic agent on membrane structure of erythrocyte ghosts and the mechanism of membrane fusion. *Nature.* 271:672-674.
157. Jackson, P.C. and J.B. St.John. 1982. Effects of 2,4-dinitrophenol on membrane lipids of roots. *Plant Physiol.* 70:858-862.
158. Martin, C.E., K. Hiramitsu, Y. Kitajima, Y. Nozawa, L. Skriver and G.A. Thompson Jr. 1976. Molecular control of membrane properties during temperature acclimation. Fatty acid desaturase regulation of membrane fluidity in acclimating Tetrahymena cells. *Biochemistry.* 15:5218-5227.
159. Oshino, N., Y. Imai and R. Sato. 1966. Electron-transfer mechanism associated with fatty acid desaturation catalyzed by liver microsomes. *Biochim. Biophys. Acta.* 128:13-28.
160. Kameyama, Y., S. Yoshioka and Y. Nozawa. 1984. Mechanism for adaptive modification during cold acclimation of phospholipid acyl chain composition in Tetrahymena. I. Principal involvement of deacylation-reacylation. *Biochim. Biophys. Acta.* 793:28-33.

161. Jaworski, J.G. and P.K. Stumpf. 1984. Fat metabolism in higher plants. Properties of a soluble stearyl-acyl carrier protein desaturase from maturing Carthamus tinctorius. Arch. Biochem. Biophys. 162:158-165.
162. Pugh, E.L. and M. Kates. 1975. Characterization of a membrane-bound phospholipid desaturase system of Candida lipolytica. Biochim. Biophys. Acta. 380:442-453.
163. Slack, C.R., P.G. Roughman and J. Terpstra. 1976. Some properties of a microsomal oleate desaturase from leaves. Biochem. J. 155:71-80.
164. Sato, N., Y. Seyama and N. Murata. 1986. Lipid-linked desaturation of palmitic acid in monogalactosyl diacylglycerol in the blue-green alga (cyanobacterium) Anabaena variabilis studied in vivo. Plant Cell Physiol. 27:819-835.
165. Van Deenen, L.L.M. 1981. Topology and dynamics of phospholipids in membranes. FEBS Lett. 123:3-15.
166. Robertson, J.D. 1982. Membrane structure. J. Cell Biol. 91:189-204.
167. Kates, M. 1988. Personal communications. Department of Biochemistry, University of Ottawa, Ottawa, Ontario, Canada.