

**Investigation into the Mechanical Properties and Structural Behaviour of Recycled  
Concrete Members**

Meika Hayles

A thesis submitted in partial fulfillment of the requirements for the  
Master of Applied Science in Civil Engineering

Department of Civil Engineering  
Faculty of Engineering  
University of Ottawa

## **Abstract**

Recycled concrete aggregates (RCA) are an eco-sustainable alternative to traditional aggregates. The equivalent mortar volume method has been developed to design RCA concrete with comparable mechanical and strength properties to natural aggregate concrete by accounting for the adhered mortar that distinguishes RCA from natural aggregates. This method also presents an opportunity to reduce the cement content of RCA concrete, increasing its cement efficiency. Modifications to mix design procedures were introduced to improve the fresh state properties of RCA concrete with a 19% cement reduction compared to the control mix. Beams cast with the RCA concrete had similar flexural capacity to corresponding control beams, however the shear strength varied as a function of RCA content in the concrete. Polished core samples taken from RCA members showed that crack development and aggregate interlock in RCA members is influenced by the aggregate properties and the spacing of coarse aggregates, indicating that knowing the compressive strength of RCA concrete is not the only parameter required for member design.

## **Acknowledgements**

First and foremost, I would like to acknowledge the efforts of my supervisors, Dr. Martin Noel and Dr. Leandro Sanchez from the Civil Engineering Department at the University of Ottawa. Their knowledge, help and guidance throughout the research process was essential to the completion of this final product.

The laboratory testing undertaken as part of the research was aided by a number of individuals. Lab supervisors, Muslim Majeed and Gamal Elnabelsya offered to help with everything from day to day tasks, to batching concrete along side of me and their assistance is greatly appreciated.

The effort put by my colleagues and fellow students did not go unnoticed. From shoveling and sieving aggregate, weighing out materials, building rebar cages and testing beams, the time and sweat they put into these tasks were crucial in completing this research. Mayra Grazia and Aynsley Griffin deserve additional thanks for their on-going support throughout my studies, making the long days put in so much more enjoyable.

Lastly I would like to thank Natural Sciences and Engineering Research Council of Canada (NSERC) for the funding they provided for this research project and LafargeHolcim and Tomlinson Group for generously supplying aggregates used to conduct this research.

## Table of Contents

Abstract.....	ii
Acknowledgements.....	iii
Table of Contents.....	iv
List of Figures.....	vii
List of Tables.....	viii
1. Introduction.....	1
1.1. Background.....	1
1.1.1. Cement and the Environment.....	1
1.1.2. Aggregates and the Environment.....	2
1.1.3. Construction and Demolition Waste.....	3
1.1.4. Historical Usage of Recycled Aggregates.....	3
1.1.5. Existing Structures Using Recycled Aggregate Concretes.....	4
1.1.6. Eco-Efficient Concrete in Industry and Research.....	5
1.2. Research Objectives and Scope of Work.....	7
1.3. Thesis Organization.....	9
1.4. Important Terms and Definitions.....	9
2. Literature Review.....	11
2.1. Recycled Concrete Aggregates.....	11
2.1.1. Production of RCA.....	11
2.1.2. Physical Properties of RCA.....	13
2.1.3. Residual Mortar Content.....	14
2.2. Design with RCA.....	17
2.2.1. Direct Replacement Design Methods.....	18
2.2.2. Equivalent Mortar Volume Method.....	18
2.2.3. Modified EMV.....	20
2.3. Mechanical Properties of RCA Concrete.....	20
2.3.1. Compressive Strength.....	20

2.3.2.	Tensile Strength .....	23
2.3.3.	Elastic Modulus .....	24
2.3.4.	Microstructure.....	25
2.4.	Long Term Performance of RCA.....	27
2.4.1.	Creep and Shrinkage .....	27
2.4.2.	Permeability .....	27
2.4.3.	Chloride Penetration .....	28
2.4.4.	Freeze-Thaw Resistance .....	29
2.5.	Structural Performance of RCA Concrete.....	29
2.5.1.	Flexural Performance.....	29
2.5.2.	Shear Performance .....	31
2.6.	Existing Standards and Guides for RCA and RCA Concrete .....	33
2.6.1.	CSA Standards .....	33
2.6.2.	ACI.....	34
2.6.3.	RILEM .....	34
2.6.4.	Germany.....	35
2.6.5.	New Zealand .....	36
2.7.	Minimum Cement Content in Design Codes .....	37
2.8.	Research Gaps and Objectives .....	38
3.	Eco-Efficient Recycled Concrete Aggregate Mix for Structural Applications .....	40
3.1.	Introduction .....	40
3.2.	Equivalent Mortar Volume Method .....	42
3.3.	Research Significance .....	45
3.4.	Materials and Methods .....	45
3.4.1.	Materials .....	45
3.4.2.	Mix Designs .....	47
3.5.	Experimental Results.....	49

3.5.1.	Fresh State.....	49
3.5.2.	Mechanical Properties.....	51
3.6.	Analysis and Discussion.....	55
3.6.1.	Mechanical Properties of RCA concrete.....	55
3.6.2.	Mix Optimization.....	58
3.6.3.	Cement Efficiency .....	64
3.7.	Conclusions .....	66
4.	Investigation of Structural Behaviour .....	69
4.1.	Introduction .....	69
4.2.	Beam Design .....	70
4.3.	Test Setup and Instrumentation.....	74
4.4.	Experimental Results.....	74
4.5.	Discussion .....	78
4.6.	Summary .....	84
5.	Conclusions.....	86
6.	References.....	91
Appendix A: A Modified EMV Design Method Example .....		105
Appendix B : Stress-Strain Curves for Concrete Cylinders.....		108
Appendix C: Beam Test Strain Gauge Data .....		112

## List of Figures

Figure 1-1: Waldspirale Residential Complex, Darmstadt, Germany [12] .....	4
Figure 1-2: Samwoh Eco-Green Building in Singapore. ....	5
Figure 2-1 Schematic of EMV Method Design Principle.....	19
Figure 2-2: Ratio of RCA to Control Compressive Strength Across Multiple Studies .....	22
Figure 3-1: Visual Comparison of RCA Concrete Cylinders .....	50
Figure 3-2: 25 MPa Cylinder Compressive Strength at 7, 14 and 28 Days.....	52
Figure 3-3: 35 MPa Cylinder Compressive Strength at 7, 14 and 28 Days.....	52
Figure 3-4: Tensile Splitting Strength, $f_t$ , vs Calculated Modulus of Rupture, $f_r$ .....	54
Figure 3-5: Measured Elastic Modulus, $E_m$ , vs Calculated Elastic Modulus, $E_c$ .....	55
Figure 3-6: Cross section of an RCA cylinder highlighting the location of embedded asphalt .....	56
Figure 3-7: Crushed RCA Cylinder showing cracks within RCA.....	58
Figure 3-8: Comparisons of Abrams Law and a modified Abrams Law for RCA concrete ...	60
Figure 3-9: Compressive Strengths of 35MPa Concrete Made with a Modified EMV.....	63
Figure 4-1: Shear Failure Beam Design.....	72
Figure 4-2: Flexural Failure Beam Design .....	72
Figure 4-3: Beam Cross-section and Stirrup Design .....	73
Figure 4-4: Images of each test beam at failure .....	75
Figure 4-5: Flexural Beam Load-Deflection Curves .....	76
Figure 4-6: Shear Beam Load-Deflection Curves .....	77
Figure 4-7: Locations of concrete cores taken in flexure members.....	80
Figure 4-8 – Cracked surfaces with different proportions of coarse RCA .....	81
Figure 4-9 – Polished concrete core surface showing crack propagation.....	83

## **List of Tables**

Table 2-1: Maximum Replacement Ratio of Coarse NA by RCA for Concrete Exposed to Various Environmental Conditions .....	35
Table 2-2: Replacement Maximums for RCA from New Zealand Guide [107] .....	36
Table 2-3: Minimum Cement Requirements by International Design Standards.....	37
Table 3-1: Acronyms used while the mix- design of RCA concrete using the EMV.....	43
Table 3-2: Properties of RCA and Natural Aggregate.....	47
Table 3-3: RCA Concrete Mix Design Proportions.....	48
Table 3-4: RCA Concrete Fresh State Properties .....	50
Table 3-5: Modified RCA Mix Designs .....	59
Table 3-6: Optimized RCA Mix Design.....	62
Table 3-7: Binder Intensity of RCA Concretes.....	66
Table 4-1: Testing Matrix .....	71
Table 4-2: Concrete Strength at Time of Testing .....	71
Table 4-3: Beam Design Data.....	73
Table 4-4: Beam Performance .....	74
Table 4-5 Crack development at Service Load.....	77

## **1. Introduction**

### **1.1. Background**

Globally, concrete is the most widely used construction material with 450 kg per person being consumed annually worldwide as of 2009 [1]. As a result, the CO<sub>2</sub> emissions from the production and distribution of concrete are substantial, on the order of 5% of total emissions annually [2]. The main constituent responsible for greenhouse gas emissions is Portland cement, while the extraction and transportation of aggregates adds to the overall embodied energy of concrete and other environmental impacts.

Recycled concrete aggregates (RCA) are receiving increasing attention as a potential approach to reduce the impact that such a widely used material has on the environment. Combining this with other methods for improving the eco-sustainability of concrete, such as reducing binder and cement content, there is the potential to create a concrete that effectively balances performance and holistic environmental impact.

#### **1.1.1. Cement and the Environment**

Cement production is an intensive process that generates a lot of pollution from start to finish. Large amounts of thermal energy are required for the calcination and drying processes as well as operation of the kiln at extremely high temperatures. Energy is also consumed heavily by fans, and mills used to grind down the material into the very fine particulate size required for cement. As a result of these steps, large amounts of CO<sub>2</sub> and other emissions are generated in the production of cement [3]. The environmental sustainability of cement can be improved by reducing the levels of contaminants emitted and consumption of fossil fuels during its production. Alternatively, the environmental sustainability of concretes can be improved by reducing the volume of cement in the concrete's mix design [4].

To compensate for these issues, it is common practice today and, in many places, required by law, that ready-mix concrete facilities replace a portion of the cement in their concrete with supplementary cementitious materials (SCMs). SCMs include materials such as blast furnace slag, and fly ash which are waste by-products generated from other industrial processes such as steel manufacturing and coal power plants [4]. Once considered useless, SCMs are now commonly used to reduce the cost of concrete for the manufacture and reducing the carbon footprint of concrete by incorporating these waste materials that would otherwise be discarded. Alternatively, the efficiency of concrete can be improved by simply creating a design with fewer cementitious materials overall [2].

### **1.1.2. Aggregates and the Environment**

The environmental impact of concrete does not only include material production. Transportation has a huge impact on the both the environmental and monetary costs of a project, particularly as large urban centres continue to grow [5]. As of 2009, estimates placed the average consumption of aggregates in Ontario at 14 tonnes per capita, 81% of which was used in the construction of buildings, roads and other infrastructure [6]. Sourcing high-quality aggregate near city centres is becoming more difficult; populated areas, for example the Greater Toronto Area import most of its aggregate from neighbouring districts because nearby supplies have been depleted [6]. Coarse aggregate is the largest component of concrete by volume. Traditionally this has been because natural aggregates have been much cheaper than any of the other constituents of concrete, however the cost rises as the transportation distance increases. Being able to provide an alternate source of coarse aggregate that can be locally sourced, is readily available, and simple to use is one way that the eco-sustainability of concrete can be improved without significantly increasing the cost of the material.

### **1.1.3. Construction and Demolition Waste**

Global initiatives to promote the recycling of materials have been increasing, particularly in more recent years. The Netherlands requires that all concrete from construction and demolition waste (C&DW) be recycled. Norway recycles nearly 95% of its concrete from C&DW, and Japan predominately uses recycled concrete as underlay for paving applications [1]. In Canada, the construction waste was estimated to be at 11 million tonnes per year as of 2009; of this 53% was concrete [7]. Finding applications for the recycled materials being produced to add value and divert them from landfills is a key measure for promoting environmentally sustainable construction in the future.

Recycled concrete aggregates (RCA) provide a sustainable alternative to the production of new aggregate material and help reduce the impact of waste generated during the demolition of existing infrastructure [8]. RCA is generally made from crushed concrete that has been either generated from demolition, or from excess concrete that is returned to the ready-mix plant. RCA can be used in place of natural coarse aggregates in the design of new concrete and prevents material from being sent to landfill.

### **1.1.4. Historical Usage of Recycled Aggregates**

Research into the use of RCA as a replacement for aggregates in concrete is a not a new field. The benefits of utilizing waste materials in the production of new concrete began as early as the 1940's as part of a cost saving measure during and in the years following the second world war [5].

More recently the environmental impact of recycled materials has become of interest fueling more research into the applications of this material. The widespread use of concrete as a construction material give it a significant role in the future of sustainable development [9].

The predominate use of RCA at present is for road underlay, backfill and non-structural concrete applications [10]. In some cases, the use of RCA for these applications is not only permitted but required. In South Korea for example, partial replacement with RCA is required for road subbase [11]. RCA in structural concrete is a bit more limited as confidence in RCA is lacking, which is likely a result of lack of experience and technical guidelines on its use, as well as various research studies available in the literature reporting that concrete made with RCA is an inferior building material to conventional concrete made with natural aggregates. Nevertheless, it is likely that economic and environmental pressure to use RCA for structural concrete will continue to increase in the coming years, and certain existing showcase structures have already begun to incorporate some RCA concrete (although these cases are still quite rare).

#### **1.1.5. Existing Structures Using Recycled Aggregate Concretes**

The Waldspirale complex completed in 2000 in Darmstadt, Germany, was one of the first structures to use concrete made using partial replacement of coarse aggregates with RCA. The building has many “green” features, and coarse RCA was used for many of the internal structural elements [12].



**Figure 1-1: Waldspirale Residential Complex, Darmstadt, Germany [12]**

The Samwoh Eco-Green Building in Singapore was completed in 2010 using concrete made with 100% recycled concrete aggregates for some structural members [13]. These are just some examples available of RCA concrete being used outside a laboratory setting and can serve as models for what can be done with RCA concrete in the future.



**Figure 1-2: Samwoh Eco-Green Building in Singapore, an example of the structural applications of RCA currently in place [13].**

Despite the introduction of initiatives to promote the use of RCA, such as LEED credits and the cost savings associated with recycled materials, lack of knowledge about its behaviour has led to misconceptions about the performance and durability of RCA concrete. Codes and standards are hesitant to incorporate RCA mix designs into their documents and industry professionals are cautious when adopting new techniques and procedures for dealing with alternative aggregates.

#### **1.1.6. Eco-Efficient Concrete in Industry and Research**

The general consensus in the concrete industry is that RCA is an inferior product that is inadequate for structural applications, and even when the replacement level is kept minimal as a “safety” precaution. RCA concrete is most often used for low-risk applications such as

paving, sidewalks and other non-structural applications. Furthermore, the replacement with RCA is often limited to a low percentage, often less than 30%. Reduced cement concrete is also a concern in design with the common perception that a reduction in the volume of cementitious materials in a concrete mix design will reduce the strength and long-term performance of concrete. The current recommendations in Canada for RCA are limited to road base and non-structural applications, with no mention of its potential as a structural material [14]. Many international concrete design codes have similar restrictions or recommendations, limiting the amount of RCA that can be used in a project [15–17]. Similarly, lower limits for cement content place restrictions on the amount of cement that a concrete must contain, even if all performance requirements are otherwise met [18–20]. While CSA standards do not prescribe a value explicitly, ACI 211.1-91 is the standard adopted for mix design and limits cement content to a minimum of 335 kg/m<sup>3</sup> for any applications where any exposure to moisture, chlorides or sulphates is anticipated.

Despite the limitations mentioned above, research on the use of RCA as a material for structural applications indicate that when the unique structure of RCA is properly studied and accounted for, the performance of RCA concrete is comparable to concrete made with natural aggregate sources. Fathifazl et al. [21] introduced the concept of equivalent mortar volume in their research, one of the first research methods to acknowledge the presence and properties of residual mortar on RCA particles and its effects on the composition of RCA concrete. Developing a mix design procedure that accounted for this residual mortar, the researchers were able to produce concrete members with the same capacity of the traditional concrete members [22–25]. Further research showed that the long term performance and durability of concrete was not impacted in any significant way by the presence of RCA [26–28]. Similarly, the cement content of concrete has been shown to be unrelated to its durability and long-term performance when designed appropriately [29–32]. Combining these two techniques for

improving the eco-sustainability of concrete has not been studied in any depth at this time. The shortcomings of RCA concrete resulting from an improper understanding of how it works or by obtaining poor quality materials have generally been addressed by decreasing the amount of RCA used and/or increasing the amount of cement used to improve strength and long-term performance. A holistically sustainable concrete could be achieved by combining techniques to incorporate RCA and reduce the cement content of the concrete as both are effective tools to reduce the cost and carbon emissions associated with concrete production.

## **1.2. Research Objectives and Scope of Work**

This project will look at the fresh and hardened state properties of eco-efficient concrete containing RCA and relatively low cement content. One of the main objectives of this work is to develop a practical mix design with a low environmental footprint with a particular focus on use in structural applications. Hence, the thesis will be divided into material aspects (i.e. mix design development) and structural aspects (i.e. performance of reinforced concrete beams).

The investigation of material properties focuses on the use of the EMV method, a mix-design procedure that incorporates RCA by considering the individual impacts that the original virgin aggregate (OVA) and residual mortar (RM) have on the hardened matrix of the concrete. The EMV method reduces the volume of new mortar added into the system by accounting for the residual mortar already adhered to the OVA in the RCA particles. Building on this concept, mix designs will be developed with the goal of significantly reducing the mortar content of an RCA concrete compared to a companion control mix, without compromising mechanical performance and without the need of using supplementary cementing materials (SCMs) and/or chemical admixtures. Restricting the use of admixtures and SCMs has the added benefit of allowing this study to obtain the baseline behaviour of eco-sustainable RCA concretes. With this complete, further studies may be able to build upon the findings to increase the

performance and further optimize RCA concrete mixtures. RCA used in this study will be locally sourced material that is readily available for use by nearby concrete mix facilities. The intent is to limit the amount of analysis and processing that is required on the RCA before use and employ a procedure that is simple and easy to follow to promote the use of RCA outside of laboratory settings. The goal will be to achieve a structural quality mix design that can then be used to build reinforced concrete beams.

The second part of this thesis investigates the structural performance of reinforced concrete beams made with eco-efficient RCA concrete. The serviceability and ultimate limit states behaviour of the beams will be evaluated, and a particular emphasis will be made on linking the material characteristics of the RCA concrete to the response of the large scale structural beams. In particular, a better understanding of the cracking mechanism will be sought, with the aim of explaining the observed differences in behaviour in concrete beams containing large amounts of RCA.

The general intent of this research is to demonstrate that RCA usage can be expanded beyond just non-structural applications. By using straightforward mix-design procedures and no admixtures, the goal is to improve confidence in RCA concrete among industry professionals and help to facilitate more widespread and smarter use of eco-efficient concrete.

The specific objectives of this study are outlined below:

1. Use locally sourced RCA with minimal known properties along with the EMV method to develop RCA concrete mixtures with reduced cement contents and up to 100% RCA replacement using two different aggregate sources.
2. Characterize the hardened state properties (i.e. compressive strength, tensile splitting strength and elastic modulus) of RCA mixtures designed with the EMV method to assess the mechanical performance of lower cement RCA concrete.

3. Optimise the EMV method for improving the quality of RCA mixtures, especially in the fresh state.
4. Evaluate the structural behaviour (flexural and shear capacities) of beams with different reinforcement configurations and replacement levels of RCA, and link the structural behaviour to material characteristics of the RCA.

### **1.3. Thesis Organization**

This thesis is divided into five chapters. This introduction presents an overview on the current use of recycled concrete aggregates and their benefits. This is followed by Chapter 2, a detailed literature review of topics including the properties of RCA, mix proportioning methods, RCA concrete performance, measuring the eco-efficiency of concrete and existing recommendations and standards for using RCA concrete and their limitations. Chapter 3 is a reproduction of a journal paper currently under review by *Construction and Building Materials*, which focuses on the materials aspects of the project. It evaluates the properties of the RCA used in the project, develops eco-efficient mix designs, identifies issues with the designs and optimizes the use of eco-efficient concrete for structural applications. Chapter 4 builds on the material development by examining the impact of RCA at different replacement levels on the performance of full-sized structural members. Reinforced concrete beams with different replacement levels were tested to failure in shear and flexure to study the influence of RCA properties on service performance and ultimate capacity. Finally, Chapter 5 summarizes the conclusions of this research work and proposes some recommendations for future work.

### **1.4. Important Terms and Definitions**

The following terms and abbreviations appear extensively throughout this document:

RCA: Recycled Concrete Aggregates. Aggregates produced by crushing waste concrete. For the purposes of this project, RCA will refer to coarse aggregates only ( $>4.75\text{mm}$  nominal diameter), unless otherwise noted.

RCA Concrete: Concrete that has been created by replacing some portion of the natural coarse aggregate with RCA. May also be referred to in some literature as Recycled Aggregate Concrete (RAC).

NA: Natural Aggregates. Aggregates derived from traditional sources and that have not been used for any applications previously.

RM: Residual Mortar. The portion of the RCA comprised of hydrated cementitious materials and fine aggregates.

RMC: Residual Mortar Content. The percentage of RCA that is residual mortar. RMC is a physical property of RCA and unique to each aggregate sample.

Conventional Concrete: Concrete made with natural aggregates (i.e. without any use of RCA). Control or companion mixes referred to in this project are conventional concretes.

OVA: Original Virgin Aggregates. The natural coarse aggregate used to produce the source concrete for the RCA.

EMV Method: Equivalent Mortar Volume Method. The design procedure developed by Fathifazl et al. [21] for optimizing the hardened matrix of RCA Concrete.

Direct Replacement Design: Design methods for RCA concrete that replace some portion of natural aggregates with RCA and do not account for the presence of residual mortar.

## **2. Literature Review**

Existing research on the use of RCA is often varied and inconsistent given the wide range of material properties and mix design methodologies used. The results of studies on concrete made with RCA are highly dependent on the quality and source of the RCA. Synthesizing current knowledge to extract the main findings across studies with different materials and mix designs is essential to build confidence in use of the material and lead to more widespread adoption of RCA in the construction industry.

### **2.1. Recycled Concrete Aggregates**

RCA is a multi-phase material generated from the crushing of hardened concrete to an appropriate size distribution to be reused as a replacement for traditional natural aggregates (NA) [8]. The environmental benefits of their use is evident, as RCA can be produced from concrete that was once part of an existing structure or by crushing excess concrete returned to production facilities, and thus divert waste material from landfills and reduce the consumption of raw materials.

#### **2.1.1. Production of RCA**

Hardened concrete from demolition waste or returned material is first processed through a jaw crusher to break the concrete down into manageable sizes, similar to that of traditional aggregate. After an initial sizing, any undesirable material must be removed before the RCA can be processed any further. The undesirable material can include products such as reinforcing steel which has been intentionally added to the concrete, or other construction debris, such as plastics, wood or organic material that has become incorporated into the waste [8]. *ACI 555R-01: Removal and Reuse of Hardened Concrete* [17] recommends that this screening be followed by an initial crushing phase and use of a magnet to remove any remaining reinforcing steel from the concrete, as well as another screening to remove any non-metallic debris from

the RCA followed by another crushing cycle. The final steps in the process are to wash the RCA to remove any remaining contaminants and fine material before screening and grading the material according to the needs of the user.

Alternatively, the RCA can be created from concrete that has been returned to a ready-mix facility because of excess unused material or unsatisfactory fresh state properties [33]. In this case, the concrete is poured off the truck and allowed to set or partially set before primary crushing [1]. With this product, the screening, sorting and cleaning is a much less labour-intensive process than the true “reused” material because from the time it is poured until the crushing stage there has been little opportunity for deleterious materials to contaminate the concrete. Another added advantage to this method is that the exposure of the concrete to unfavourable environmental conditions, such as the presence of chlorides, carbonation and sulphate attack, is limited, and in some cases the original material properties such as compressive strength and air entrainment may be known (which is often not the case for demolished concrete) [34].

The presence of residual mortar on RCA also provides an additional opportunity to design concrete mixes with low mortar content and therefore less cement by replacing fresh mortar with an equivalent volume of hardened mortar [35]. Much of the research that does exist on RCA does not account for the presence of the residual mortar on the hardened matrix of the concrete [5,33,36–43] and some recommend higher cement contents when using the material [25,36]. This occurs primarily because of the belief that RCA concrete is always of inferior quality to conventional concrete [34,44]. It has been shown that any cost or environmental savings achieved using RCA may be negated by heavy dosages of cement, which itself is both expensive and environmentally unsustainable [9].

Grading of RCA is a function of the mechanical processes used to crush and sort the material. In the absence of other guidelines, it has been recommended to account for the physical properties of RCA the same as would be done for NA [14]. As a result, studies conducted on RCA generally grade the aggregate according to the same standards that are used for NA, for example, CSA A23.1 [14], ASTM C33 [45], or AASHTO M 80[46]. Studies suggest that producing RCA of a satisfactory grading is possible through standard crushing methods, although removal of excess fine material may be required if it is not to be included in the final mix design [47].

### **2.1.2. Physical Properties of RCA**

Although it has been used to replace natural coarse aggregates, RCA has many characteristics that are different from NA. The presence of residual mortar is largely responsible for these differences [48]. The mortar component of concrete has a different density, porosity and chemical composition than natural aggregates. Furthermore, with the use of supplementary cementing materials (SCMs) and admixtures in the parent concrete, the mortar composition can vary significantly between RCA samples [49].

#### **2.1.2.1. Absorption**

All design procedures must consider the physical properties of RCA which can vary significantly from NA. RCA is, on average, much more porous than NA and has a higher absorption capacity because of the adhered mortar [47]. The properties of the concrete used to produce the RCA have nearly limitless possibilities and as a result, the properties of the RCA that are directly related to the volume of adhered mortar can vary significantly across different studies with different sources of RCA. Absorption of RCA is closely related to the pores and water absorption of the residual mortar (RM) [50]. Despite having higher water absorption on average, the time required for RCAs to become fully saturated can be longer than NA and this

should be accounted for both in design and in tests requiring RCA to be at saturated surface dry (SSD) condition [51].

The increased variability in absorption capacity makes it a critical parameter for design with RCA. A review of existing research into the absorption of RCA yields results ranging from a negligible difference in absorption capacity when compared to NA, to values as high as 11.6%, which is more than 20 times higher than the lowest value reported [52–55].

#### **2.1.2.2. Density**

A lower specific gravity, when compared to NA, is also typical of RCA as a result of the presence of adhered mortar. Increasing residual mortar content (RMC) can therefore be correlated to both an increase in the absorption capacity and a decrease in density [48]. Research has shown that the wet density of RCA concrete tends to be lower than that of NA concrete mixes, on average by 6% [47] with a possible contributor to this reduction in wet density is an increase in air content of the aggregates themselves.

#### **2.1.3. Residual Mortar Content**

What is considered by many to be the most important and distinguishing feature of RCA is the presence of residual mortar [49]. Once crushed, the RCA is comprised of two main components, the original virgin aggregate (OVA), and the residual mortar (RM). The OVA is what is traditionally thought of as coarse aggregate: any type of natural stone or gravel that was used in the original concrete mix greater than 4.75 mm or retained by a No. 4 sieve. The RM is the mortar from the original concrete that has stayed adhered to the OVA throughout the crushing and cleaning processes [7]. The RM is comprised of cement and any SCMs that were used in the original concrete mix, as well as fine aggregates. The properties of the RM are what distinguish RCA from natural aggregates (NA). While it is possible to remove all the mortar from the RCA to achieve a usable NA, the time and energy required to do so are

counterproductive [56]. Being able to classify the residual mortar content (RMC) of an RCA sample is an important step in making appropriate mix designs that account for the uniqueness of the material [7]. RMC is a function of the crushing process used to create the RCA and the mechanical properties of the concrete at the time of crushing. There is no set standard for quantifying the RMC of RCA although several methods have been developed. The main principle of many of these methods is the same: the mass of the RCA is taken before and after the residual mortar is removed. The RMC as a percentage can then be calculated as follows [7]:

$$\% \text{ RMC} = \frac{\text{Mass of RCA} - \text{Mass of RCA without mortar}}{\text{Mass of RCA}} \times 100 \quad (2-1)$$

#### 2.1.3.1. Image Analysis

Considered by some researchers to be the benchmark for quantification of RMC, image analysis studies aim to compare the area of RM to the area of OVA on a flat surface using microscopic or petrographic methods. Abbas et al. [7] used this method of analysis as a reference point for evaluating new tools in the determination of RMC. Liu et al. [57] also used this method for studies related to the mechanical properties of RCA. Despite the accuracy of the method, the current lack of automated tools makes it extremely time consuming and therefore not used in practice.

#### 2.1.3.2. Heat Treatment

At temperatures above 400°C, the chemical bonds that have formed as a result of the hydration process in the mortar begin to break down [58–60]. Tests performed on concrete exposed to high temperatures have verified this phenomenon and hence this degradation process can be used to the benefit of designers working with RCA. If the RCA is exposed to high temperatures in a kiln (studies suggest anywhere from 2-24hrs) the cement in the mortar will begin to break

down, while the OVA remains unaltered [49]. After the RCA is cooled down to room temperature the RM can easily be removed manually with a rubber mallet or similar instrument. This method was found to be more effective for large particles (>4.75 mm). For smaller particles, additional methods must be employed to remove the mortar and get an accurate measurement of RMC [49].

#### **2.1.3.3. Acid Solution**

A popular method of mortar removal involves soaking aggregates in an acid solution, often 0.1M hydrochloric, sulphuric or nitric acid [56]. After 24 hours of soaking in a solution the aggregates are rinsed with distilled water to completely remove the acid solution. Care needs to be taken with this method that the acid will not react with the original virgin aggregate, which occurs when the material is limestone based. Handling of these acids needs to also be done with care, and proper disposal is essential. Ultimately the recommendation of studies using this method was not to use the acid-pres soaking as a means of measuring the RMC of an RCA source, but rather to remove all the RM from the RCA and improve the quality of the aggregate by simply reducing it back to just the OVA, which is more expensive and labour intensive in the long term than using the entirety of the RCA [61].

#### **2.1.3.4. Freeze-Thaw Cycles**

Research conducted by Abbas et al.[7] has led to the development of a new simplified method for quantifying the RMC in RCA samples. The first step in the method is to subject representative samples to tests per ASTM C 127 to obtain porosity and specific gravity of the RCA with attached residual mortar. The samples subsequently undergo a series of 5 freeze-thaw cycles in a sodium sulphate solution [7] to remove the mortar from the RCA to calculate the percent mortar by weight of the RCA. The results of this quantification procedure were verified using petrographic imaging analysis. The advantage that this method holds over those

previously mentioned is that it significantly reduces the time and labour required to calculate RMC and requires only lab equipment that is readily available [1].

As an alternative to the lengthy freeze-thaw cycles, a method has been proposed that combines liquid nitrogen baths and microwave oven cycles [62]. The samples are first fully submerged in water for 36 hours before being immersed in a liquid nitrogen bath for 25 minutes, then transferred to another container and heated in a microwave oven for 35 minutes. The cooling and heating sessions are repeated a total of 5 times in immediate succession. Lastly, the mortar is removed manually with a hammer. Both approaches were found to have similar efficacy, but the sodium sulphate method was preferred due to the easier application and lower demand for chemicals [62]. This same study also aimed to remove additional mortar from the aggregates by soaking them in a solution of salicylic acid dissolved in methanol. This procedure was found to be effective when the size of the particles was small (<1mm) but the additional step did not show much change in the measured residual mortar content for coarse aggregates.

## **2.2. Design with RCA**

Investigations of the use of waste concrete as an aggregate began as early as the late 1940's. Further research into the material continued to develop with more interest picking up in the 1970's as existing structures began to be demolished and new ones built. A paper published in 1986 by Hansen summarised 40 years of research into the usability of RCA and concluded that 30% was the maximum recommended replacement of NA with RCA before the RCA began to negatively impact the concrete [5]. This 30% has been used and referenced as a benchmark for many studies and applications of RCA in the decades since.

Like the studies before them, current research into RCA continues to use similar design methodologies, like the direct replacement method, and low replacement percentages (i.e. < 30%). With more recent advancements in research and an increasing focus on the use of

environmentally sustainable materials, as well as a better understanding of how to increase the replacement percentage of RCA, new methods of design are being developed to improve the performance and predictability of concretes made with RCA [8].

### **2.2.1. Direct Replacement Design Methods**

The earliest attempts at using RCA as a replacement for NA in concrete used direct replacement approaches. These techniques can differ slightly in execution but are based on the same concept: RCA is used to replace an equivalent quantity of NA, either by weight or volume, without considering the impact that residual mortar has on the concrete design.

The results of these methods are variable, but nearly all show a similar trend. An increase in the amount of RCA used to replace NA is correlated to a decrease in mechanical performance [35]. The conclusions from many of these studies recommend an upper bound limit on the permissible percentage replacement with RCA, often less than 30%. Improvement of the strength and fresh properties of these concretes can sometimes be achieved through the addition of admixtures and SCMs or pre-treatment of the RCA [47]. To the author's knowledge, no studies have reported equal or improved mechanical properties using a direct replacement method and 100% replacement with RCA without additional modifications to materials and/or mix designs.

### **2.2.2. Equivalent Mortar Volume Method**

Another mix design procedure was developed that accounts for the RMC of RCA through a new design parameter [35]. The equivalent mortar volume (EMV) method recognises that RCA is a multi-phase material and cannot be assumed to behave in the same manner as NA. This approach reduces the volume of new cementitious materials in the concrete mix, accounting for the volume of RMC already present in the RCA. The governing principle behind the EMV is that the total design volumes of mortar and coarse aggregate should always remain the same,

regardless of whether the mortar is already hardened (RM) or fresh. This concept is shown schematically in Figure 2-1, and can be expressed using Equation 2-2:

$$V_{air} + V_{FA}^{NAC} + V_{cement}^{NAC} + V_{water}^{NAC} = V_{RM}^{RCA} + V_{FA}^{RCA} + V_{cement}^{RCA} + V_{water}^{RCA} + V_{air} \quad (2-2)$$

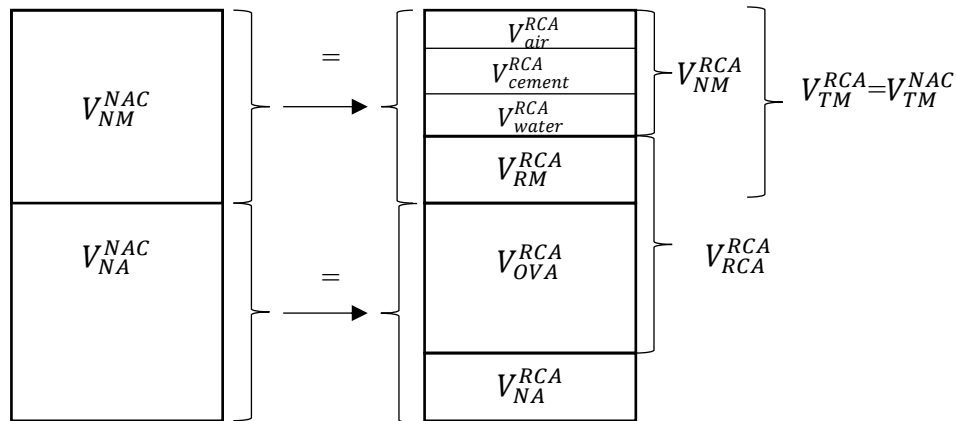

**Figure 2-1 Schematic of EMV Method Design Principle**

where  $V^{NAC}$  refers to the volume of a constituent within the normal aggregate concrete and  $V^{RCA}$  is the volume of a constituent within the RCA concrete. Subscripts on both  $V^{NAC}$  and  $V^{RCA}$  denote each of the constituents. FA and RM represent the fine aggregates and residual mortar respectively, while subscripts TM and NM refer to the proportions of Total Mortar and New Mortar in the designs.

Using this method, the designer can specify the volumetric ratio of NA in the RCA concrete to aggregate in the control mix with, denoted by  $R$ :

$$R = V_{NA}^{RCA} / V_{NA}^{NAC} \quad (2-3)$$

Where  $V_{NA}^{RCA}$  and  $V_{NA}^{NAC}$  are the volumes of natural aggregate in the RCA mix and in the control mix design, respectively. With this relationship,  $R = 0$  corresponds to a mix that does not contain any natural aggregates, and  $R = 1$  is the control mix, or no RCA. This factor  $R$  is then used to calculate the required volume of mortar in the RCA mix design. The required masses of water, cement and fine aggregates are scaled down accordingly based on the reduced volume of mortar.

Past researches show the use of EMV and conventional methods to mix- design RCA concrete mixes with fresh aggregates to RCA replacement ranging from 60% to 100%. Results showed that RCA mixes proportioned with the EMV method could obtain comparable mechanical properties to concrete made entirely with natural aggregates using traditional mix design methods [35].

### **2.2.3. Modified EMV**

Although the concept behind the EMV procedure is quite innovative and scientifically sound, it has been found that a weakness of the method is the often found difficult behaviour in the fresh state of mixtures proportioned through this method. This happens very likely due to the use of the RMC to reduce the volume of mortar in the RCA concrete and thus forces designers to increase significantly either the amount of binders or admixtures (or both) which plays against sustainable actions.

Building on the principles of the EMV, a modification was proposed by researchers to improve the fresh state properties of RCA concrete intended for paving applications. A scale factor was introduced to the mix design procedure to modify the percent replacement of the RCA and the usable proportion of the RMC [11]. Combining this modification with water reducing admixtures, mixes were designed for paving applications having the adequate compressive strength and mechanical properties. The focus of the study was improving the fresh state properties of concrete proportioned using the EMV method and keeping the consumption of sand as high as possible as is desirable for paving concretes. This modification allowed concrete to be designed with 100% RCA but the design was not suitable for structural applications and the cement content was not optimised [55].

## **2.3. Mechanical Properties of RCA Concrete**

### **2.3.1. Compressive Strength**

Compressive strength is often considered by many in the construction industry to be one of the most important criterion for evaluating the performance of concrete. Usually, concrete strength is measured by a uniaxial compressive test on a cylinder with a diameter of 100 mm and 200 mm high. Water to cement (w/c) ratio is widely regarded as the most important factor in the compressive strength of concrete, but other factors also include the type and quality of aggregate, admixture type and content, air content, maturity and curing practices. Although nearly all studies on RCA report the compressive strength of concrete, it is difficult to compare across studies because of these factors. The comparison is better done by examining the difference in strength between RCA concretes and control concretes within a single study. Figure 2-2 shows the impact of the percentage replacement of RCA on the 28-day compressive strength of concrete.

All of the concrete mixtures presented in Figure 2-2 used a direct replacement method without any attempt to improve the strength of the material, with the exception of the study by Fathifazl et. al.[35]. Replacement percentages up to approximately 30% show very little change in the strength of the material. As the replacement percentage increases, the strength of the concrete tends to decrease, sometimes significantly. At the 100% replacement level, the strength decrease resulting from the use of RCA was as high as 30%. Some researchers have suggested that decreasing the w/c ratio for RCA is one method that may be used to improve the strength of RCA concretes. The magnitude of the decrease will always vary for different sources of RCA and would need to be assessed on a case by case basis.

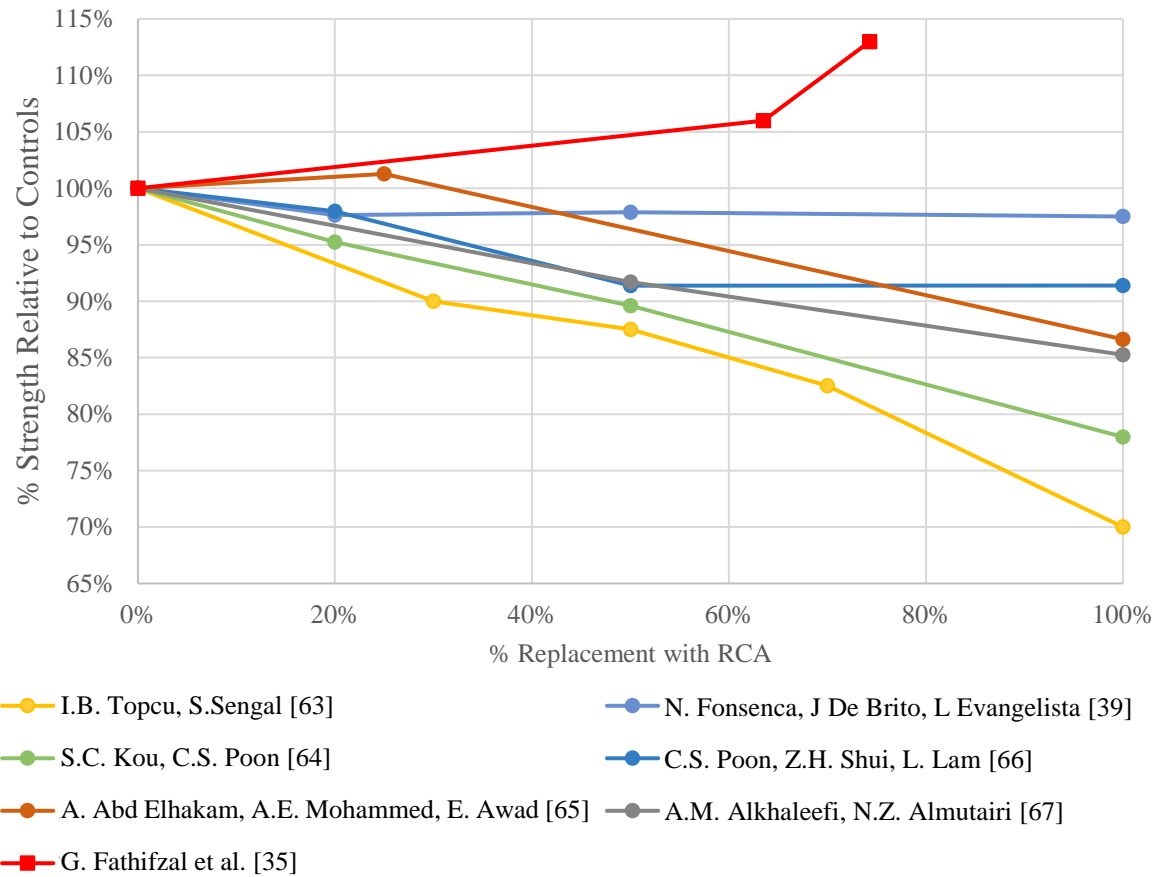

**Figure 2-2: Ratio of RCA to Control Compressive Strength Across Multiple Studies**

The EMV method described above was developed as an improvement to direct replacement methods. Using the EMV or a modified EMV improves the performance of RCA at high replacement levels and little to no decrease in strength is observed for cylinders made according to these methods [35]. Rather than compare compressive strength directly to RCA content it is more appropriate to compare compressive strength to RMC or other properties of the RCA [35] as these can vary from source to source and the quality of RCA can have a significant impact on the properties of RCA concrete just as natural aggregate plays a role in the properties of traditional concrete.

### 2.3.2. Tensile Strength

Direct measurement of the tensile strength of concrete is difficult to obtain in many cases. One of the more common indirect methods for assessing the tensile strength of concrete is the splitting tensile strength which applies load longitudinally on a concrete cylinder forcing it to “split” in two [68]. The splitting tensile strength of RCA concrete, like compressive strength, is a function of several factors, including the w/c ratio, aggregate quality, and replacement ratios. In general, the tensile strength of concrete, no matter how it is measured, is related to the compressive strength. Codes and standards often adopt empirical equations to relate the tensile strength (or modulus of rupture) to the compressive strength of the concrete, such as that provided in CSA A23.3-14[69], given as follows:

$$f_r = 0.6\sqrt{f'_c} \quad (2-4)$$

with  $f_r$ , the modulus of rupture being proportional to the square root of  $f'_c$ , the compressive strength of the concrete. As the compressive strength increases, the tensile strength also increases. Based on a statistical study by Mirza et al., splitting tensile strengths are approximately 75% of modulus of rupture values on average [70]: the average  $f_t$  is  $0.53\sqrt{f'_c}$  compared to  $f_r = 0.69\sqrt{f'_c}$ .

This trend is also observed with RCA concrete; studies have reported a decrease in splitting tensile strength with increasing RCA content, as would be expected from the lower compressive strengths [16,64,71]. The decay in splitting tensile strength is not as apparent as the compressive strength decrease with studies showing a maximum difference of approximately 10%. There was little difference in the splitting tensile strengths of the RCA concrete and the control mixtures below 30% replacement and the strength decrease also seems to taper off as the replacement percentages approached 100% [47].

### 2.3.3. Elastic Modulus

The elastic modulus of concrete is largely governed by the quality and properties of the aggregates used [72]. However, elastic modulus is also related to compressive strength and can be calculated using empirical equations, although not always accurately because the aggregate type/amount is neglected. CSA A23.3-4-14 [14] recommends the following equation to relate the elastic modulus to the compressive strength for normal strength and density concrete:

$$E_c = 4500\sqrt{f'_c} \text{ (MPa)} \quad (2-5)$$

Similarly, ACI 318-14 [73] provides an equation also as a function of concrete strength, given as follows:

$$E_c = w_c^{1.5} * 0.403\sqrt{f'_c} \text{ (GPa)} \quad (2-6)$$

with  $w_c$  being the density of the concrete in  $\text{kg/m}^3$ . Research that uses direct replacement methods to study the impact of RCA on the elastic modulus of concrete report a decrease in the elastic modulus correlated to an increase in the replacement percentage of RCA. Similar to compressive and tensile strengths, the biggest decrease in the elastic modulus was measured when the replacement percentage was increased beyond 50% [47]. Early research into RCA conducted in the mid-1990s by Topcu and Guncan showed an 80% decrease in the elastic moduli for RCA concrete [74]. A better understanding of the properties of RCA has led to slight improvements in the way it is designed since that time. Research by Kou et al. observed 12.6% and 25.2% decreases in the elastic moduli of concretes with 50% and 100% replacement with RCA respectively [64]. Rahal reported a much less significant decrease of 3% with 100% RCA replacement [33]. Xiao et al. also found a decrease in the elastic moduli of 45% when 100% RCA was used [75]. This same study concluded that the existing empirical formulas provided by CSA A23.3 and ACI 318 were not accurate in predicting the elastic modulus of

RCA concrete. A modified equation was developed as a result, incorporating the percentage replacement as a parameter relating compressive strength to elasticity. The variation in the source and quality of the RCAs as well as the target strengths of the concretes are major contributors to the differences found between the studies. This confirms the importance of understanding the properties of each RCA sample before its use.

A study of the EMV method for proportioning RCA concrete compared the effectiveness of developing a concrete with equivalent stiffness to conventional concrete [35]. Tests indicated that this design procedure was able to produce concrete with comparable or higher elastic moduli to the conventional concretes prepared. The EMV method always produced concrete with a higher elastic modulus than the direct replacement methods also, cast for comparison in this study.

#### **2.3.4. Microstructure**

A defining characteristic of RCA concrete is the presence of residual mortar on the aggregates. This property introduces multiple types of interfacial transition zones (ITZ) to the material. The first exists between the OVA and new paste where the RCA does not have residual mortar; the second type exists between the OVA and the RM; and the third is found between the new mortar in the concrete and the RM [76]. The microstructure of RCA is dependent on the RM content, surface area (of the OVA, RM and the RCA as a whole), grading of the RCA and percentage of replacement used. The method of crushing the RCA has been found to influence the microstructure of the concrete. Researchers have shown that minimal crushing of the RCA can introduce microdefects into the aggregates, while further processing could force failure at these points, and excessive crushing can excessively reduce the size of the particles and make them unusable for the intended application. The ideal amount of processing balances these risks and benefits [77].

The presence of the RM means that failure planes in RCA concrete can develop differently than in conventional concrete. Failure planes in RCA concrete may develop because of one or more of the following:

- Failure in the old mortar
- Failure in the new mortar
- Failure through aggregates (OVA or NA where  $R > 0$ )
- Failure at new ITZ
- Failure at old ITZ

As with normal strength concrete made with NA, failure typically initiates at the ITZ with cracks propagating through the mortar and around aggregate particles. The old ITZ is usually associated with a higher porosity and more cracks, making it the weakest component of the concrete [78].

Differences in mortar strength were also found to play a role in the failure of RCA. In cases where the new mortar had a significantly higher w/c ratio than the old mortar, the new ITZ and mortar were found to be the governing criteria for the failure and strength. In contrast, in concretes where the w/c ratio of the old mortar was significantly higher than the new mortar, the old ITZ and mortar governed and the strength of the RCA concrete failed to achieve the same strength as the control concretes with the same mortar and only NA. Unfortunately, the compressive strength of the parent concrete is often unknown. The microstructure of RCA has been examined using techniques such as scanning electron microscopy [79,80] and energy dispersive x-ray analyser, but these tools are time consuming and often not feasible to use on each sample of RCA.

## **2.4. Long Term Performance of RCA**

Sustainability of a construction material is not only measured by the impact of the processes used to manufacture it but also the maintenance, repair requirements, and overall lifespan. Durability is an issue to be considered for any concrete, especially in winter climates where freeze-thaw cycles and exposure to de-icing salts is of high concern.

One of the biggest challenges with respect to the durability of RCA concrete is assessing the impact of cumulative damage on the performance of RCA concrete. When RCA is produced from construction and demolition waste, the prior use and exposure of the RCA could be an important factor in how it should be used. Embedding RCA that has already been subjected to chloride exposure, carbonation or having ASR gel could very well reduce the usable lifespan of the new concrete.

### **2.4.1. Creep and Shrinkage**

When proportioned with direct replacement methods, RCA concrete shows higher creep and drying shrinkage than NA concrete [26,27,30,81,82]. This difference has been attributed to the increase in absorption capacity typical of RCA, and the creep and drying shrinkage were found to increase with the volume of RM in the mix relative to the new mortar [83].

Conversely, concrete proportioned with the EMV method was found to be comparable to concrete made with NA in terms of creep and shrinkage [26], with superior durability properties compared to concrete with the same RCA proportioned with a direct replacement method.

### **2.4.2. Permeability**

Most of the studies examining the permeability of RCA show that RCA concrete is more permeable than NA concrete. This is true when comparing both the water permeability and capillary water absorption of RCA concrete [64,83,84]. A review by Kisku et al. [47] concluded

by looking at multiple studies that an increase in water absorption of RCA concrete can be correlated to an increased percentage of replacement with RCA, noting however that with less than 30% replacement there is little impact on the permeability of RCA concrete when compared to conventional concrete. With 100% replacement, water absorption was seen to increase for all studies; the control values ranged from 3.5% to 6.5%, which increased to 6.0% to 9.5% when no natural aggregates were used.

Some studies have shown that the increase in permeability associated with the use of RCA can be combatted with one of a few modifications. An extended wet curing process was shown to decrease the water absorption and air permeability of RCA concrete when compared to concrete that was not cured [84]. The use of fly ash or slag as a replacement for cement has also been shown to offset the reduction in durability that resulted from the use of RCA [85,86].

### **2.4.3. Chloride Penetration**

The resistance of RCA concrete to chloride penetration has been found to decrease as the percentage replacement with RCA is increased [47]. However, as with conventional concrete, the chloride penetration was also found to be largely dependent on the w/c ratio and recommendations were made to apply an upper bound value to the w/c ratio, as is traditionally done with conventional concrete to increase durability and resistance to chloride penetration [87–89].

Aside from adjusting the w/c ratio, there are other techniques to improve the resistance to chlorides of RCA concrete. Washing RCA before using it was found to be a simple and effective approach to removing existing contaminants and improving durability [90]. Replacing Portland cement with fly ash in the new mortar was also found to improve the resistance to chloride penetration [88]. The addition of fly ash or slag was also recommended

to improve the durability of RCA concrete proportioned with the EMV method and provided results comparable to that of the conventional mixes studied [28].

#### **2.4.4. Freeze-Thaw Resistance**

The resistance to freeze-thaw of RCA concrete, like the other durability properties examined in this chapter, was found in most cases to decrease with an increase in the replacement of NA with RCA [47,91–94]. The properties of the RM on the RCA were largely held responsible for the increased mass of concrete observed during the freezing and thawing cycles, with one author citing that if the parent concrete of the RCA was not air-entrained, any replacement of NA with RCA could be detrimental on the performance of the concrete in cold weather conditions [94]. The performance of RCA concrete proportioned with the EMV method was found to be comparable to the control mixes studies, a result of keeping the total mortar volumes consistent between the two mix designs [28].

### **2.5. Structural Performance of RCA Concrete**

The feasibility of RCA concrete for structural applications is dependent on more than just the performance of cylinders in compression. In addition to the compressive strength and other mechanical properties of the cylinders, structural member capacity and serviceability performance are dependent on many criteria, including aggregate interlock, bond behaviour, crack width and crack propagation that must be examined on a larger scale.

#### **2.5.1. Flexural Performance**

A review of reported values for the cracking and ultimate moment resistance of reinforced concrete beams made with RCA concrete found that their flexural behaviour is comparable to control beams made with NA concrete when tested under static loading [47]. Research conducted by Ajdukeiwicz et al. [95] concluded that the 3.5% reduction in flexural capacity observed in the 100% RCA, under-reinforced beams was negligible. Similar research

conducted by Ignjatović et al. [10] compared control beams to companion specimens made with 50% and 100% replacement with RCA. That study concluded that the replacement ratio with coarse RCA had little to no effect on the load-deflection behaviour, service load deflection, ultimate moment capacity or the linear strain distribution over the height of the beams with steel yielding at approximately the same load in all cases. Concrete designed using the EMV method described earlier in this section was also found to have comparable or superior strength to control members [25] and was true for both under and over-reinforced beams. The study looked at RCA concrete made from two different sources and developed a separate mix design for each with one having 63.5% RCA and the other made with 73.5% RCA replacement. The cracking moment and crack spacing were found to be lower in these members than in the control beams but were underpredicted by ACI 318 models. ACI 318 and Eurocode 2 equations did accurately predict the load-deflection behaviour of the beams, with Eurocode 2 being slightly more accurate for beams with a lower reinforcement ratio [25]. Using data from 194 sources as part of a review, Tošić et al. [96] analysed existing data on the flexural and shear capacities of RCA concrete and compared the results to values predicted by Eurocode 2. The standard was found to accurately predict the flexural strength of under-reinforced RCA beams with both 50% and 100% replacement, and the researchers stated that no changes to the provisions are required to accommodate these materials.

Flexural fatigue behaviour of RCA members has been studied less and the results appear to be inconclusive. Arora and Singh [38] demonstrated that concrete made with 100% RCA has a higher variation in its fatigue performance than control members (higher variation is a common characteristic of RCA concrete), but that overall the RCA concrete did not perform as well as the control beams. The two million cycle endurance limit was used as the comparison of fatigue performance with 100% RCA having 50% of the static flexural strength, 14% lower than the value of 58% observed for the control members [38]. Another study by Xiao et al. showed that

the fatigue behaviour of RCA concrete did not vary significantly from that of NA concrete but noted that the fatigue life of RCA concrete is lower than NA concrete when the same stress levels are compared. It does not appear that the impact of the RCA replacement percentage on the fatigue behaviour of concrete has been studied previously in any detail.

### **2.5.2. Shear Performance**

Some of the studies on RCA members indicate that shear performance is reduced if transverse reinforcement is not provided. Looking at beams with higher RCA replacement levels, the shear capacity of RCA beams was found to drop as much as 17% for beams with 100% RCA [97]. It has been observed that for low replacement ratios (i.e. < 25%) the shear behaviour of concrete is not impacted by the presence of RCA [41]. This study also found that with an increased RCA replacement proportion, shear cracks formed at lower loads, even though the compressive strength was found to be the same as the control members studied. This observation is not always consistent though, since other studies show a less drastic drop in shear capacity with the use of RCA, or none at all, as was the case with experiments conducted by Choi et al. [98] and González-Fonteboa et al. [99]. In both these studies the experimental capacity of the beams without shear reinforcement was comparable to or exceeded the capacities predicted by the design standards used for comparison.

Improving the shear capacity of beams without transverse reinforcement, as well as the consistency of results, has been done by introducing a number of modifications to mix and design procedures. Katkhuda and Shatarat examined the impact of pre-treating RCA with a hydrochloric acid bath on the shear capacity of RCA beams [100]. They concluded that for beams with 50-100% RCA, pre-treating the RCA increased the shear capacity, whereas RCA that had not been pre-treated reduced the strength when compared to control members by up to 20%. The difference in capacities was attributed to the pre-treating process improving the bond

between the RCA and new mortar. Using fly ash with RCA was found to have mixed results on the shear capacity of beams without transverse reinforcement. After testing beams with 50% fly ash and 50% RCA, one study concluded that although beams containing either fly ash or RCA performed similarly to the control concrete beams, combining the two resulted in a decrease in shear capacity of up to 18% [101]. The same study found that for the beams tested, ACI 318-14 [73] was conservative in predicting the shear strength of the beams, whereas CSA A23.3 [69] overestimated the shear capacity by up to 10%. Where the EMV method was used to design reinforced concrete beams without stirrups, the shear capacity and behaviour of the beams were found to be similar to the conventional control beams and within the limits of many design standards [23]. Crack widths were observed to be larger for the RCA beams than for the conventional beams, but within ACI and CSA code limits and the authors noted that RCA beams appeared to be more ductile after the formation of shear cracks than conventional beams.

In cases where transverse reinforcement was provided, the behaviour of RCA concrete members have been found to be more consistent and exhibit behaviour that is better predicted by current design codes without modifications. Choi and Yun studied beams with 100% RCA and concluded that the shear behaviour and failure modes were in agreement with the conventional beams studied and recommended the ACI 318-14 [73] design equations without modifications as a conservative method of designing for shear in beams made with RCA [98]. González-Fonteboa and Martínez-Abella noted in their research that the differences in shear cracking observed between RCA and conventional concrete beams can be well controlled with the addition of transverse reinforcement. The experimental shear capacity of all the beams studied exceeded the predicted shear capacity of the international design codes they examined, including ACI 318-14 and CSA A23.3-14 [99]. Using the EMV method to proportion concrete mixes resulted in RCA members that had on average a slightly higher shear strength than the conventional beams, with code predictions being conservative for all members tested [24]. A

comprehensive study of RCA beams identified 25 studies of beams exhibiting shear failure with stirrups and compared the results to predicted strengths using Eurocode 2. The results of this comparison were inconclusive, noting that the Eurocode 2 was both inaccurate and imprecise, albeit conservative [96]; the authors concluded that more research is needed to better understand the shear behaviour of RCA beams with transverse reinforcement.

## **2.6. Existing Standards and Guides for RCA and RCA Concrete**

With a higher emphasis being placed on sustainable development, design codes are beginning to adopt provisions that allow for the use of recycled materials in concrete mix designs. The standards that do currently exist often limit the amount of replacement that is permitted, recommending only non-structural applications or providing only “suggestions” for how to use RCA.

### **2.6.1. CSA Standards**

CSA A23.1-14 adopted Appendix O in its most recent revisions, which addresses concrete made with RCA [14]. Along with Appendix M, which addresses the need for sustainable development with concrete, these sections provide recommendations for implementing RCA concrete in the field. The recommendations in these appendices focus primarily on the use of RCA in non-structural applications, such as sidewalks, curbs and fill [14].

The standard highlights the importance of quality control for RCA concrete, with a few properties highlighted. Within the code itself, Clause 8.11.1.1.2.1 simply states the RCA can be used if it does not negatively impact the performance of the concrete. The additional recommendations in the appendices are that RCA should be free from foreign materials, high levels of chlorides, high levels of sulphates and alkali-aggregate reactivity; shrinkage in RCA concrete should be addressed and care should be taken to ensure that the compressive strength of the RCA is at least comparable to the new mix design. The section concludes by

recommending that RCA be held to the same standards as natural aggregates and with the correct research and development low-to-moderate levels of RCA may be permitted in low value applications [14].

CSA A23.3-14 [69], which deals with the design of concrete structures, makes no mention of the use of RCA in concrete mix designs for structures.

### **2.6.2. ACI**

Similar to the Canadian standards, ACI 318-14, which covers the design of concrete structures, makes no mention of the use of RCA for structural applications [73]. ACI 211.1-91, which has long been the design standard for concrete mix designs, also fails to incorporate any details pertaining to the inclusion of RCA in concrete [102]. ACI has published a technical document *ACI 555R-01: Removal and Reuse of Hardened Concrete* which exists to serve as a guideline for the production and use of RCA [103]. It summarises research into the use of RCA up to the time it was published (2001) and provides some information about special concerns and considerations to address when using RCA. Similar to the recommendations of CSA A23.1-14 [14], the report highlights the need for understanding the durability of RCA as a replacement for natural aggregates. The report serves only as a source of information and guideline to the use of RCA with no explicit rules or provisions provided [103].

### **2.6.3. RILEM**

European guidelines for RCA were last published by RILEM in 1994. The recommendations cover the use of coarse aggregates made from crushed masonry, concrete and a combination of recycled and natural aggregates [104]. Much like the North American standards, the guide outlines several tests and procedures to follow to ensure that the quality of the RCA will not be detrimental to the concrete, especially as it relates to durability. Tables are provided to help with the classification of aggregates and provide limits for properties such as density and

absorption while also placing limits on the amount of deleterious materials present to help with quality control of the RCA [104]. There have been a substantial number of studies conducted with RCA in the decades since this report was published and not all recommendations and findings are up to date with current research.

#### 2.6.4. Germany

Germany has codified its requirements for the properties of RCA in *DIN 4226-100, Aggregates for Mortar and Concrete, Part 100—Recycled Aggregate* [105], published in 2002 with further information on RCA concrete supplemented by the German Committee for Reinforced Concrete recommendations initially published four years prior [15]. These two documents together provide guidance and restrictions for the use of RCA in concrete.

Depending on the composition of the aggregates, RCA is divided into one of four classes, Types 1-4. Limits on density, absorption and chemical contaminants are restricted by class. Type 1 and Type 2 are considered higher quality aggregates and permitted for use in concrete with some limitations. Maximum replacement with RCA is restricted by exposure class, with the upper limit for all concretes set at 45%. The applications of RCA concrete are also restricted; lightweight and prestressed concrete cannot be made with RCA [105].

**Table 2-1: Maximum Replacement Ratio of Coarse NA by RCA for Concrete Exposed to Various Environmental Conditions**

Environmental Class, per EN-206:2013 [18]	Exposed Condition	Replacement Amount, %	
		Type 1	Type 2
<b>XC1</b>	Carbonation	≤45	≤35
<b>X0</b>	No Attack		
<b>XC1 &amp; XC4</b>	Carbonation		
<b>XF1 &amp; XF3</b>	Freeze-thaw without salts	≤35	≤25
<b>XA1</b>	Chemical attack	≤25	≤25

(Adapted from de Brito and Saikia's book *Recycled Aggregate in Concrete* [106])

### 2.6.5. New Zealand

In 2011, the Cement and Concrete Association of New Zealand first published their recommendations for the use of RCA as *Technical Report 14 - Best Practise Guide for the use of Recycled Aggregates in New Concrete* [107]. The guide is more recent and thorough than many other international guides for RCA and covers a variety of items including demolition and collection, testing and physical properties, and design and use. Similar to European and North American guides, the document outlines a number of the physical properties and limitations that RCA must meet in order to for it to not interfere with the durability of the concrete. Unique to this guide are specific upper limits to the percentage replacement, provided as a function of the target strength of the material, the values of which are provided in Table 2.

**Table 2-2: Replacement Maximums for RCA from New Zealand Guide [107]**

<b>Specified Compressive Strength</b>	<b>Percentage on Coarse Aggregate Fraction</b>
Up to and including 17.5 MPa non-structural concrete	100%
17.5 MPa structural concrete	100%
20 MPa structural concrete	50%
25, 30, 35 MPa structural concrete	30%
40, 45, 50 MPa structural concrete	10%

For higher strength structural concretes, the recommended maximum replacement with RCA is only 10%. The value presented is conservative when compared to the results of the current body of research. Some studies, like that conducted by Fathifazl et al. [21] using the EMV method, show that mixes with over 50% RCA can create concrete with strengths greater than 40 MPa having sufficient mechanical properties.

## 2.7. Minimum Cement Content in Design Codes

Nearly all design standards for concrete include some provision for the minimum amount of cement or cementitious materials to be provided in a mix design [31]. The reasoning for this requirement varies from document to document, but there are a few commonalities between them. Minimum cement content is often recommended to ensure the protection of reinforcing steel against various exposure conditions, to ensure adequate workability of the concrete and a fully developed matrix. The lower bound on cement content in concrete in many design codes exists to ensure concrete durability rather than as a concern about strength or mechanical performance and this is especially true in areas where concrete is regularly exposed to freeze thaw cycles, de-icing salts and other conditions known to cause the deterioration of concrete. A summary of some international design code requirements for minimum cement content in structural concrete is provided in Table 3.

**Table 2-3: Minimum Cement Requirements by International Design Standards**

Code	Minimum Cement Content (kg/m <sup>3</sup> )	Notes
CSA A23.1-2014 [14]	-	Not limited <sup>1</sup>
ACI 211.1-91 [102]	335	Freeze-thaw, de-icer, or sulfate exposure
New Zealand Standard 3101[19]	350	
EN 206-1:2013 (European Standard) [18]	260-300 300-320 300-340	Mild to severe carbonation exposure Mild to severe chloride exposure Mild to severe freeze thaw attack
IS-10262-2009 (India) [20]	300-360	Mild to extreme exposure conditions

1. In practise in Canada the ACI design procedure is often used and as a result the lower limit of 335 kg/m<sup>3</sup> is often adopted, even if no minimum is required by governing codes

In some cases, cement content may also be related to the target strength of a concrete, as is the case for European and German Standards, but there is a large body of evidence indicating that for a fixed water to cement ratio the cement content is not an important factor in the compressive strength [31].

## **2.8. Research Gaps and Objectives**

Many of the studies presented consider the performance of RCA concrete with respect to one narrow aspect. Structural research studies often do not provide a full understanding of why certain behaviours are displayed or work with material optimisation, while studies that focus on the mechanical properties of RCA quite often do not scale their studies up to examine the structural behaviour of the material. Furthermore, many research studies look at the impact of using RCA with known properties or take advantage of techniques and equipment available at research institutions that may be impractical or infeasible to use in industry or on a larger scale. Where the emphasis is placed on improving the mechanical performance of RCA, it is easy to forget the primary reasons for using RCA, which are costs savings and improvement of eco-sustainability. The addition of cement and chemical admixtures are effective approaches to improve the workability and, depending on the binder and admixtures types, the mechanical properties of RCA, but come with increased cost and are associated with a higher amount of CO<sub>2</sub> production.

To address the gaps in the existing research into RCA concretes, the primary goal of this study will be using the EMV method to develop holistically eco-friendly concrete mix designs with RCA and reduced cement contents with the intent of optimizing the mix for structural applications. Use of admixtures, SCMs and additional material processing will not be used in this project so that the baseline behaviour of the material might be properly studied and understood before modifications and optimizations are introduced.

Analysis of the beams will be done by examining performance at serviceability and ultimate limit states, with a particular emphasis on crack propagation and linking behaviour with RCA material properties and comparing them to conventional concrete members to observe any significant differences. Lastly, the applicability of existing design standards for predicting the

behaviour of eco-sustainable concrete made with RCA and lower cement contents will be studied to provide a final recommendation on how to design and properly use the concretes developed.

### 3. Eco-Efficient Recycled Concrete Aggregate Mix for Structural Applications

The chapter has been prepared as a reproduction of a journal paper currently under review by Construction and Building Materials. The structure of this chapter is reflective of the format required by the publication.

#### Abstract

Research has shown that good quality recycled concrete aggregates (RCA) can be produced for structural applications if the aggregate properties are properly considered in the mix design, especially the residual mortar content (RMC). Previous studies on RCA have generally used mixes with moderate to high cement contents, which negates many of the environmental and economic advantages of this material. In this study, the *equivalent mortar volume* (EMV) method was used to develop RCA mixes with the aim of minimizing new cement content by accounting for the RMC already present, thus improving binder efficiency. Conventional RCA mixes (i.e. 25 and 35 MPa compressive strengths) containing low cement content were developed without any chemical or mineral admixtures. A modified EMV method was proposed to overcome challenges encountered in the fresh state and an optimized 35 MPa mix was developed with a low binder intensity of  $9.2 \text{ kg/m}^3 \cdot \text{MPa}^{-1}$ .

**Keywords:** recycled concrete aggregate, low cement content concrete, sustainable design, concrete mix design

#### 3.1. Introduction

The use of recycled concrete aggregates (RCA) in construction industry is predominantly limited to non-structural applications, mostly due to concerns over material quality, mechanical properties and long-term performance. In fact, many studies have reported inferior behaviour of RCA concrete in the fresh and hardened states, as well as durability. The response of many researchers has been to suggest that RCA should not be permitted for use in concrete structures,

and/or that additional cement and chemicals should be added to compensate for this behaviour.

Much of the research reported in the literature implicitly treats RCA material as *homogeneous* and directly replaces certain proportions of natural aggregate in the concrete mix design, with little to no consideration made to account for both phases of the material: namely, the original aggregate particles and the residual mortar content (RMC) that remains adhered to them. Using these procedures, some percentage of natural aggregates in a mix is replaced with an equivalent mass of RCA without modifying the mix design (except perhaps to account for the higher absorption of the aggregates) [35]. Given the high variability of both the amount and quality of the residual mortar phase from different sources of RCA, it is generally difficult or even impossible to accurately predict the fresh and hardened state properties of the new recycled concrete without accounting for this parameter, and in most situations both the strength and elastic modulus are found to be lower than similar conventional concrete (CC) mixes made with natural aggregates (NA) [35].

Among the alternatives to RCA direct replacement is the previously developed *equivalent mortar volume (EMV) method* [1]. This procedure utilizes a CC control mix to develop the proportions for an RCA mix design as a function of RMC. Previous research has shown that the EMV method can be used to obtain similar behaviour for concrete with RCA as the same control mix made with NA [2, 3, 4, 5]. However, these studies have typically used a CC mix with moderate to high amounts of cementitious materials (i.e. higher than 400 kg/m<sup>3</sup>) and superplasticizer, mainly to overcome challenges in the fresh state which result when the volume of new cement paste is reduced. Considering the fact that cement production is responsible for more than 5% of CO<sub>2</sub> emissions worldwide [6], new approaches are needed with a more holistic view of sustainability which balances and optimizes the use of all constituent materials.

One measure of the environmental sustainability of concrete is its cement efficiency, which

refers to the relationship between the cement content (in mass) used in a concrete mix design and its performance (e.g. the change in compressive strength associated with one unit increase in the mass of cement). Concrete mixes with high cement efficiency have adequate strength and suitable overall performance while using lower amounts of cement to achieve these targets. Normally cement efficiency tends to increase with concrete compressive strength, but CC mixes in the range of 25-45 MPa 28-day compressive strengths are generally not eco-efficient in this respect [2]. The objective of the current study is to explore whether the EMV method previously proposed as by [1] can be used to improve binder efficiency to produce eco-efficient RCA concrete with low carbon footprint, while still meeting performance criteria in the fresh and hardened states.

### 3.2. Equivalent Mortar Volume Method

The EMV method is fully described in [1], but is briefly reviewed here for convenience. Table 3-1 summarizes all the acronyms used in the mix- design procedure for a better understanding of the EMV method.

The theory behind the EMV is that all mortar and aggregates should be treated the same, regardless of whether or not they are sourced from new material or as a constituent of the RCA. RCA is comprised of two components: the original virgin aggregate (OVA) and residual mortar (RM).

The volume of total mortar in the control mix is matched by the volume of new mortar and the RM of the RCA. Similarly, the total volume of aggregates in the control mix is matched by the volume of OVA within the RCA and new NA. The mix design should meet the following criteria:

$$V_{air} + V_{FA}^{NAC} + V_{cement}^{NAC} + V_{water}^{NAC} = V_{RM}^{RCA} + V_{FA}^{RCA} + V_{cement}^{RCA} + V_{water}^{RCA} + V_{air} \quad (3-1)$$

**Table 3-1: Acronyms used in the mix- design of RCA concrete using the EMV.**

<b>EMV Acronyms</b>	<b>Description</b>
NA	Natural aggregate
CC (or NAC)	Conventional concrete (or Natural Aggregates Concrete)
RCA	Recycled concrete aggregate
OVA	Original virgin aggregate
RM	Residual mortar
RMC	Residual mortar content
EMV	Equivalent mortar volume
$SG^{NA}$	Specific Gravity of the natural aggregate
$SG^{RCA}$	Specific Gravity of the RCA
R	Replacement ratio
$RMC_{max}$	Maximum residual content permitted in the RCA
$V^{NAC}$	Volume of a constituent within the CC
$V_{NA}^{NAC}$	Unit volume of NA within the CC
$V_{OVA}^{RCA}$	Unit volume of OVA within the RCA
$V_{NA}^{RCA}$	Volume of new aggregate in the RCA mix
$V_{RM}^{RCA}$	Volume of residual mortar in the RCA
$V_{NM}^{RCA}$	Volume of new mortar in the RCA
$W_c^{NAC}$	Weight of cement in the CC
$W_c^{RCA}$	Weight of cement in the RCA
$W_{FA}^{NAC}$	Weight of fine aggregates in the CC
$W_{FA}^{RCA}$	Weight of fine aggregates in the RCA

where  $V^{NAC}$  refers to the volume of a constituent within the normal aggregate concrete,  $V^{RCA}$  is the volume of a constituent within the RCA concrete, and subscripts FA and RM denote the fine aggregates and residual mortar respectively. The concept is to match the total volume of

the mortar in the final mix design, including mortar that has already hardened.

The design principles of the EMV employ a limiting technique to restrict the upper limit of RM on the RCA that can be used for design. For example, if the RCA is comprised only of residual mortar, it will be impossible to satisfy Equation 1. The maximum permissible design RMC content defined by [35] is given by the equation below:

$$RMC_{\max} = 1 - V_{DR-NA}^{NAC} \cdot (SG^{NA}/SG^{RCA}) \quad (3-2)$$

$RMC_{\max}$  can be correlated with a value  $R_{\min}$ , the minimum percentage value of NA required in the RCA mix design. After determining the RMC of the RCA, the desired replacement percentage is selected, ensuring that this value is less than the calculated maximum. A unit volume of NA in the control mix is then matched with the unit volume of OVA within the RCA such that the following condition is met:

$$V_{OVA}^{RCA} = V_{NA}^{NAC} - V_{NA}^{RCA} \quad (3-3)$$

where  $V_{OVA}^{RCA}$  is the unit volume of OVA within the RCA,  $V_{NA}^{NAC}$  is the unit volume of NA within the control mix and  $V_{NA}^{RCA}$  is the volume of new aggregate in the RCA mix.

Knowing the unit weights of each component,  $W^{NAC}$ , and volumes,  $V^{NAC}$ , needed for the control mix, the volumes of RCA and NA in the RCA mix can be calculated as follows:

$$V_{RCA}^{RCA} = V_{NA}^{NAC} * (1 - R) / [(1 - RMC) SG_{OVA} / SG_{RCA}] \quad (3-4)$$

$$V_{NA}^{RCA} = R * V_{NA}^{NAC} \quad (3-5)$$

The remaining volume within a unit of concrete must then be comprised of mortar, either new mortar (NM) or residual mortar (RM), and can be calculated as follows.

$$V_{RM}^{RCA} = V_{RCA}^{RCA} (1 - (1 - RMC) SG_{RCA} / SG_{OVA}) \quad (3-6)$$

$$V_{NM}^{RCA} = 1 - V_{RM}^{RCA} - V_{NA}^{RCA} \quad (3-7)$$

Once the required volume of new mortar is known, the components of the mortar are proportioned using the ratio of required new mortar in the RCA design to the total mortar in the control mix.

$$W_c^{RCA} = W_c^{NAC} * V_{NM}^{RCA} / V_{TM}^{NAC} \quad (3-8)$$

$$W_{FA}^{RCA} = W_{FA}^{NAC} * V_{NM}^{RCA} / V_{TM}^{NAC} \quad (3-9)$$

where  $W_c^{RCA}$  is the weight of cement in the RCA mix,  $W_c^{NAC}$  is the weight of cement in the control mix,  $W_{FA}^{RCA}$  is the weight of fine aggregates in the RCA mix and  $W_{FA}^{NAC}$  is the weight of the fine aggregates in the control mix.

### 3.3. Research Significance

RCA provides a sustainable alternative to the production of new aggregates and help reducing the impact of construction waste generated during the demolition of existing infrastructure. Lack of knowledge about its behaviour has led to misconceptions about the performance and durability of RCA concrete. Furthermore, to the authors' knowledge, the use of RCA and the EMV method as a means to increase binder efficiency has not been explored to date. This research focuses on a holistic approach to the sustainable design of RCA concrete by using residual mortar to reduce the cement content of new mixes, helping support a better knowledge and understanding of this eco-friendly material.

### 3.4. Materials and Methods

#### 3.4.1. Materials

RCA from two sources was obtained for use within this study. The first, Source-RU, is reused concrete material produced from waste collected from multiple demolition sites. The second, Source-RT, is produced from material returned to the concrete production facility and crushed on site to create the RCA. No additional information on the composition of the RCA was

available. An important factor in effectively using the EMV method is having an accurate measurement of the ratio of the RM and OVA within the RCA. No standard test exists for determining the RMC of RCA. Previous attempts at quantifying RMC have included petrography, application of acid solution and manual removal of the mortar [7].

Research conducted by Abbas et al. has led to the development of a new simplified method for quantifying the RMC in RCA samples [7]. All fines and deleterious materials were removed from the RCA, and the samples were taken such that the grading curve of the sample matched the grading that would eventually be used in the mix design. Samples of approximately 3.0 kg were rinsed and oven dried at 105°C for 24 hours. The dry weight before removal of the mortar was recorded. The samples were then fully submerged in a 26% by weight sodium sulphate solution and allowed to soak for 24 hours. The submerged samples were then subjected to a series of 5 freeze-thaw cycles; approximately 16 hours in a freezer at -17 °C and 8 hours in an oven at 80°C. At each transfer between oven and freezer the samples were stirred with a metal rod to help remove any loose mortar from the RCA. After the last cycle the samples were rinsed with water over a 4.75mm sieve and any remaining mortar was easily removed manually. The samples were then oven dried again for 24 hours at 105°C and gently sieved a final time before the weight was recorded. The mass lost over the freeze thaw-cycles was determined to calculate the RMC as follows:

$$RMC = [W_{RCA} - W_{OVA}]/W_{RCA} \quad (3-10)$$

The advantage that this method holds over those previously mentioned is that it significantly reduces the time and labour required to calculate RMC and requires only lab equipment that is readily available. Additional research has looked at modifying this method of assessment with an additional series of heat cycles and submersion in acid baths, but the additional time and effort required to complete this procedure was determined to outweigh the benefits of having

only slightly more accurate results [62].

Employing the method described above, the RMCs for Source-RU and Source-RT were determined. Moreover, aggregate properties for the OVA such as specific gravity and absorption were determined as per ASTM C 127 [108] on the source material once the RM has been stripped. Table 3-2 shows the results of these tests and the aggregate properties used for design with the EMV method.

**Table 3-2: Properties of RCA and Natural Aggregate**

Source	RMC	Bulk SG RCA	Bulk SG OVA	Absorption, %	$V^{NAC}_{DR-NA}$	RMC <sub>max</sub>	R <sub>min</sub>
RT	25.3%	2.39	2.68	3.13%	-	28.2%	-4.1%
RU	41.0%	2.36	2.72	3.43%	-	27.4%	18.8%
NA	-	-	2.68	0.58%	0.64	-	-
FA	-	-	2.60	0.50%	-	-	-

Keeping in mind the restrictions of the EMV method, the upper bound replacement limit with Source-RU was calculated from Equation 3-2 as 81.2% by mass. The RMC of Source-RT is low enough that there is no upper limit. The -4.1% value for the RT R<sub>min</sub> means that the calculated upper limit of RT RCA based on the given specific gravities and RMC is higher than the aggregate content if 100% natural aggregates were used. Any calculated value less than 0% for R<sub>min</sub> can be rounded to 0% and has no true upper limit on the value for RCA replacement. The RCA was paired with a natural limestone aggregate in designs that used less than 100% replacement. Natural sand, not from RCA, was used for fine aggregate.

### 3.4.2. Mix Designs

Using each of the aggregate sources, EMV mix designs were proportioned with aggregate replacement contents of 0%, 50%, and 100% RCA (50%, and 81.2% in the case of Source RU) at two different target strengths. Two different control mixes were designed with compressive

strengths of 25 MPa and 35 MPa with water-to-cement (w/c) ratios of 0.61 and 0.47 respectively. These target strengths were selected because existing research into RCA concrete has mainly focused on mixes with strengths at or above 35 MPa presenting high amount of binder, especially portland cement (PC). Many of these mixes also contained a combination of SCMs and admixtures to improve the fresh and hardened states of the concrete. Therefore, a lack of RCA studies and information accounting for more “conventional”, yet very important mixtures (i.e. 25-35 MPa represents the majority of concrete used for infrastructure construction worldwide) was found and addressed in this research.

The NA used in the control mixes and for supplementing RCA mixtures was a 19mm limestone graded to ASTM C 33 [45]. The RCA used was graded to the same standard. General Use (GU), Type 1 cement was selected for all mixes. No chemical or mineral admixtures were utilized in the mixes so that a benchmark (and full understanding) of the recycled material behaviour in the fresh and hardened states could be determined alongside with practical thresholds. A summary of all design batches is provided in Table 3-3.

**Table 3-3: RCA Concrete Mix Design Proportions**

<b>Batch Name</b>	<b>Cement, kg/m<sup>3</sup></b>	<b>Fines, kg/m<sup>3</sup></b>	<b>RCA, kg/m<sup>3</sup></b>	<b>Natural CA, kg/m<sup>3</sup></b>	<b>Water, kg/m<sup>3</sup></b>
<b>0-NA-25</b>	314	790	0	1029	192
<b>50-RU-25</b>	220	555	887	515	135
<b>50-RT-25</b>	264	665	697	509	162
<b>81-RU-25A</b>	162	405	1440	193	99
<b>81-RU-25B</b>	208	384	1367	183	127
<b>100-RT-25</b>	215	542	1380	0	132
<b>0-NA-35</b>	370	790	0	1029	174
<b>50-RU-35</b>	260	555	887	515	122
<b>50-RT-35</b>	312	666	690	515	147
<b>81-RU-35A</b>	191	408	1440	193	90
<b>81-RU-35B</b>	239	390	1375	184	113
<b>100-RT-35</b>	254	542	1380	0	119

[a] Naming convention for batches is as follows:  
(Replacement percentage) – (Aggregate Source) – (Target Strength)(Batch Letter)

Two different mix-designs, distinguished as A and B were designed for Source RU due to concerns on the material's fresh state behaviour at the maximum replacement level. After concluding that the total mortar content of the first batch was too low to bind the aggregates' skeleton together and provide the mixture with required workability for manual handling, placing and compaction, changes were made with the intention of reducing the consistency of the mix, without altering the RCA volume used. Thus, for batch B mixes, the cement content was increased while the water-to-cement ratio was kept the same, as was the amount of aggregates. This increases the overall mortar content of the mix, resulting in a mix with more suitable fresh state behaviour. A single design was used for all other mixes.

### **3.5.Experimental Results**

#### **3.5.1.Fresh State**

The low amounts of new cement paste in the RCA mix-designs lead to some issues in the fresh state, especially consistency (as measured by the slump test using the Abrams cone). The RCA concrete mixes all showed a lower slump than the control mixes, as would be expected since these mixes contain less fresh cement paste. Fresh concrete properties, including slump, air content, and fresh state density are provided in Table 3-43-4.

Not all mixes with low slump presented similar fresh properties. Mixes with higher PC content (i.e. higher RM) were easier to vibrate and produced good quality cylinders, likely presenting a rheological shear thinning (or pseudoplastic) behaviour. In cases where the total RM was significantly reduced, in particular in the "81-RU-25 -& 35" cases, the volume of new cement paste used was not enough to fully coat all of the aggregates and separate them with a "minimum" required paste thickness, forming a homogeneous matrix. Visually, a clear difference could be seen in these cylinders and a measurable difference is present in their density and air content. Figure 3-1 shows the difference between the two different batches at

the maximum replacement level.

**Table 3-4: RCA Concrete Fresh State Properties**

Batch	Slump, cm	Air Content, %	Fresh state Density, kg/m <sup>3</sup>
<b>0-NA-25A</b>	19.0	2.1	2471
<b>0-NA-25B</b>	19.5	1.4	2489
<b>50-RT-25A</b>	13.5	1.8	2406
<b>50-RT-25B</b>	11.0	2.1	2417
<b>100-RT-25A</b>	2.0	2.9	2371
<b>100-RT-25B</b>	1.5	5.5	2314
<b>50-RU-25A</b>	4.5	2.0	2406
<b>50-RU-25B</b>	3.0	3.0	2374
<b>81-RU-25A</b>	0.0	12.5	2084
<b>81-RU-25B</b>	0.0	3.7	2374
<b>0-NA-35A</b>	9.0	1.6	2483
<b>0-NA-35B</b>	8.5	1.0	2483
<b>50-RT-35A</b>	2.5	6.0	2483
<b>50-RT-35B</b>	2.0	2.4	2431
<b>50-RU-35A</b>	1.0	-	2360
<b>50-RU-35B</b>	0.0	5.1	2414
<b>100-RT-35A</b>	0.0	4.9	2266
<b>100-RT-35B</b>	0.0	-	2331
<b>81-RU-35A</b>	0.0	6.1	2243
<b>81-RU-35B</b>	1.0	7.2	2277

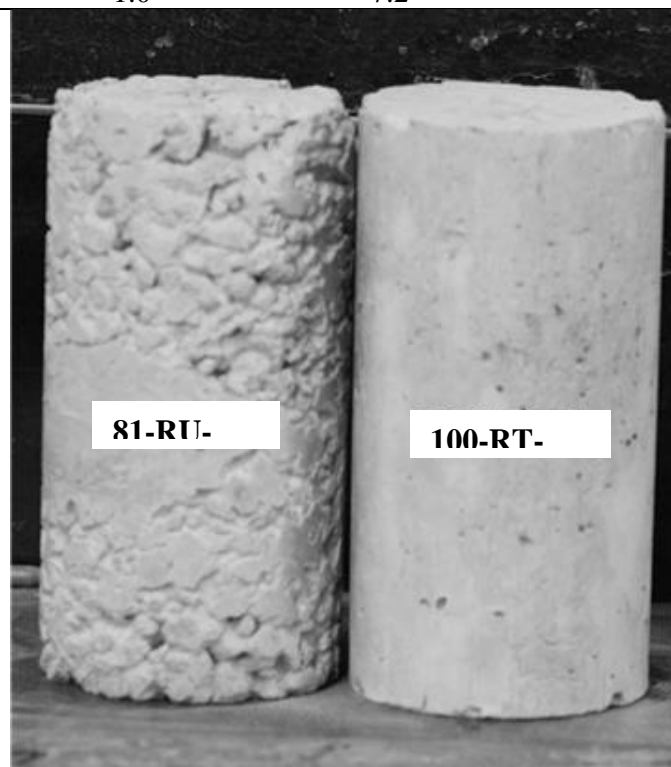

**Figure 3-1: Visual Comparison of RCA Concrete Cylinders**

Batch 81-RU-25A on the left was made with 162kg/m<sup>3</sup> of PC, while batch 100-RT-25A on the

right was made with 215kg/m<sup>3</sup> of PC. While the difference between the measured slumps of these two mixes was fairly small, 0.0 and 2.0 cm respectively, it is clear that batch 100-RT-B produced a much better quality mixture. Furthermore, all concrete samples were designed to have an air content of approximately 2-3%. In cases where the fresh concrete could not be properly compacted, the entrapped air content increased significantly, resulting in a lower density material. Referring again to the two cylinders shown in Figure 3-1 batch 81-RU-25A had an air content 10.4% higher than batch 100-RT-25A. It is worth noting once again, that all of the mixes in this study were intentionally prepared without the use of any type of admixtures (chemical or mineral).

### **3.5.2. Mechanical Properties**

#### *Compressive strength*

Cylinder compressive strengths were obtained at 7, 14 and 28 days. Three cylinders from each batch were used to measure the average compressive strength at each age. The results of these tests are presented in Figure 3-2 and Figure 3-3. The average strength of most of the RCA designs were lower than the targets of 25 MPa and 35 MPa, and the average strength reached by the control mix. The exception to this being one batch of cylinders made with 50% Source-RT RCA with an average compressive strength of 35 MPa. The cylinders cast from Source-RT material performed better on average than the cylinders made with Source RU material.

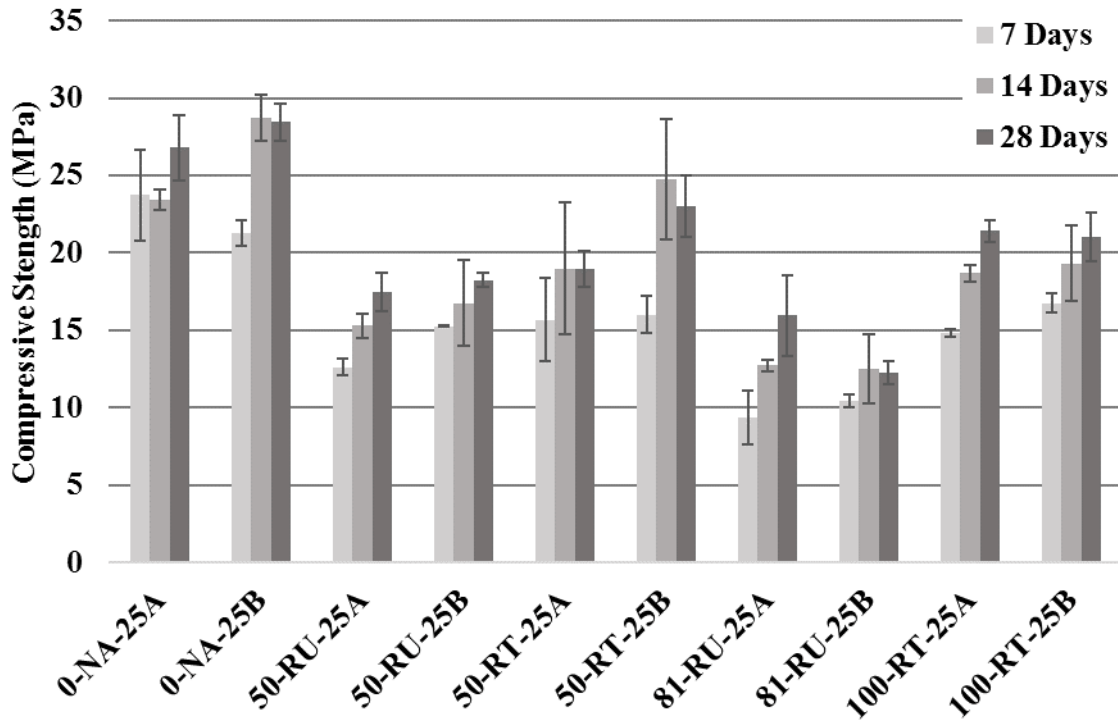

Figure 3-2: 25 MPa Cylinder Compressive Strength at 7, 14 and 28 Days

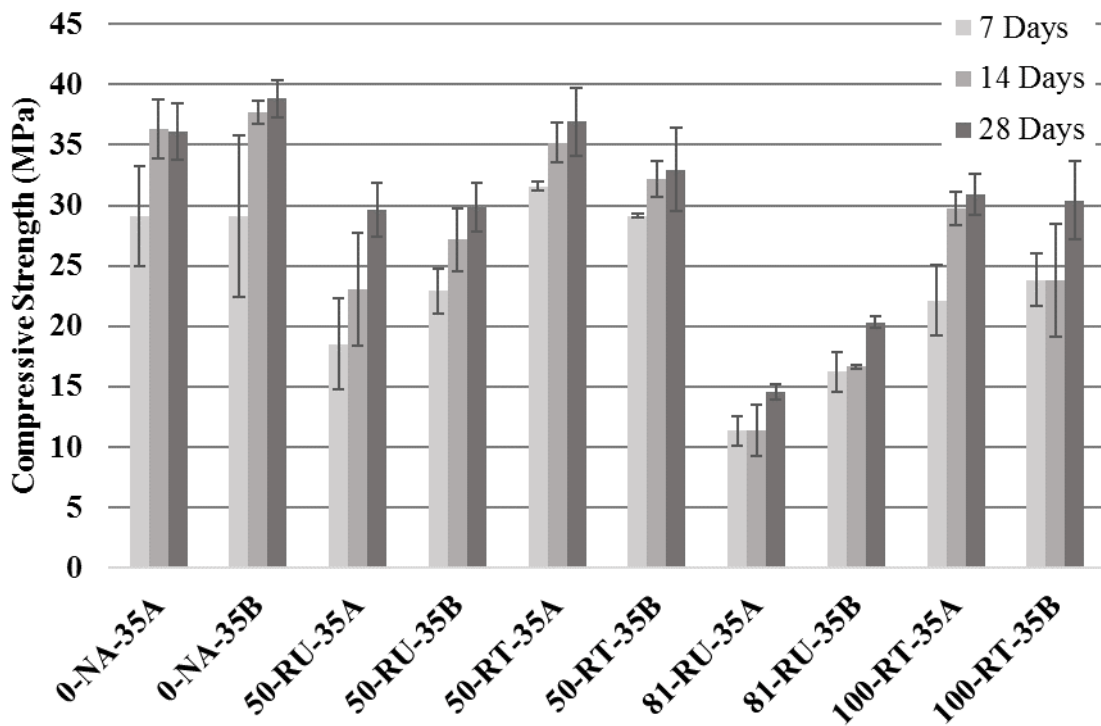

Figure 3-3: 35 MPa Cylinder Compressive Strength at 7, 14 and 28 Days

Looking at the 25 MPa target strength group, it can be observed that there was little change in the average 28-day strength of the Source-RT cylinders when the replacement percentage was increased from 50% to 100% and the cement content was reduced accordingly. Both had an average strength of 21 MPa, i.e. 16% below the target strength. In contrast, the increase in the replacement percentage in the design of the batches with Source-RU RCA corresponded to a reduction in the average strength. The average 28-day strength was reduced from 17.8 MPa at the 50% replacement level, to 16 MPa for batch 81-RU-A and 12.26 MPa for batch 81-RU-B. Batch 81-RU-B also displayed a lower average strength than batch 81-RU-A despite having more cement and being more workable.

The 35 MPa batches were generally closer to their target strengths, with one batch, 50-RT-35A, reaching an average strength above 35 MPa at 28-days, although still less than the control mix. The 100-RU-35 batches performed particularly poorly, with the likely explanation being that the reduction in the water content without the addition of cementitious materials or the use of chemical admixtures, severely compromised the fresh state properties of the mixes. This was such a threshold to the strength and quality of these concrete mixtures that even with a reduction in w/c ratio, the average strength at 28-day obtained was less than the 25 MPa mix with the same replacement level. There again was a loss in strength measured when the replacement level was increased from 50% to the maximum replacement, with both aggregate sources. With the Source-RT material the strength loss was less significant than with the Source RU mixes, 4.3 MPa as compared with 12.3 MPa on average, which again may be attributed to the better fresh state properties of the Source-RT mixes overall. The nearly 10 MPa increase in strength between the two 100% replacement mixes with Source-RT RCA is evidence to suggest that the percentage replacement with RCA is not the limiting criterion towards the compressive strength of these concretes.

### Tensile strength & Elastic modulus

Tensile splitting strength and elastic modulus were also measured at 28 days. Figure 3-4 shows the comparison between measured tensile splitting strength and the predicted modulus of rupture using the empirical method prescribed in CSA A23.3-14 as  $f_r = 0.6\sqrt{f'_c}$ . [14]. Generally, splitting tensile strengths are about 75% of modulus of rupture values on average. Based on a statistical study by Mirza et al. [70] the average  $f_t$  is  $0.53\sqrt{f'_c}$  compared to  $f_r = 0.69\sqrt{f'_c}$ . Tensile strengths were comparable to predicted values for both the control mixes and the mixes made with Source-RT material. Although a direct comparison of the two values is not appropriate, the similarity in the values indicate the actual modulus of rupture for these cylinders are close the code prescribed values. In contrast, cylinders made with Source RU material had a much lower tensile splitting strength than would be expected based on their measured strength.

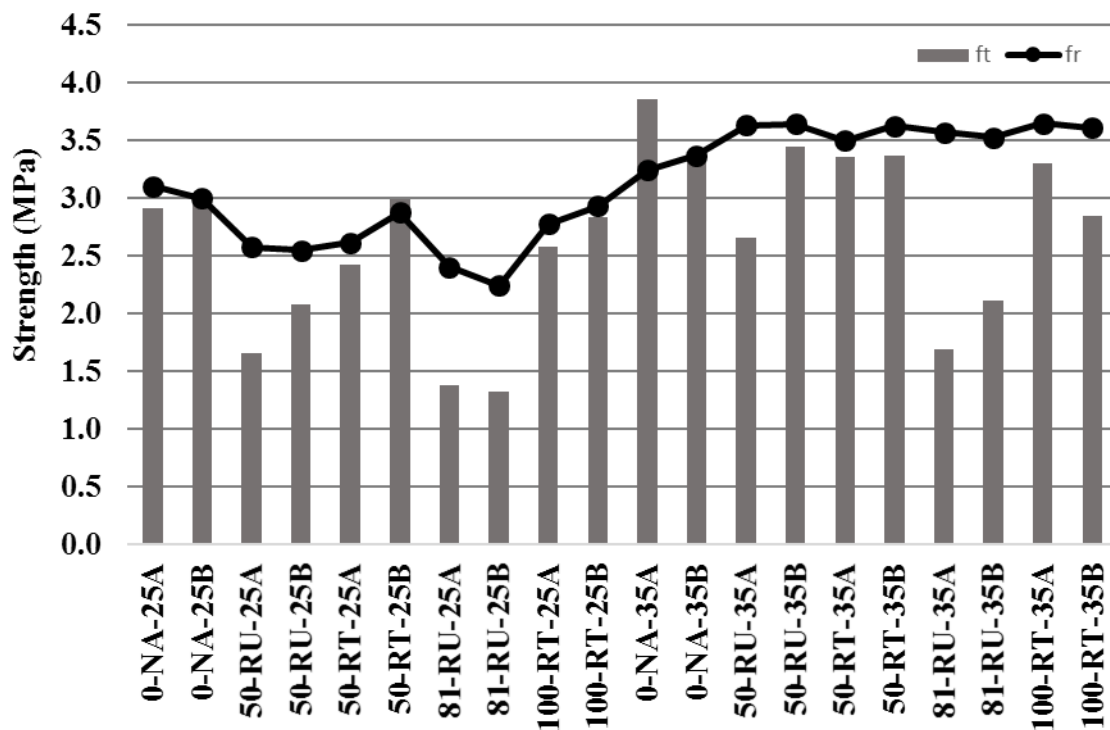

Figure 3-4: Tensile Splitting Strength,  $f_t$ , vs Calculated Modulus of Rupture,  $f_r$

The reduction in strength also corresponded to a reduced elastic modulus, with measured and predicted values summarized in Figure 3-5. Predicted values were calculated using the measured compressive strength and the formula  $E_c = 4500\sqrt{f'_c}$  provided by CSA A23.3-14 [14]. Although the RCA cylinders were found to be less stiff than the control cylinders tested, with the exception of one batch, the measured modulus of elasticity was higher than the values predicted using CSA A23.3-14 based on the average measured compressive strength at 28 days.

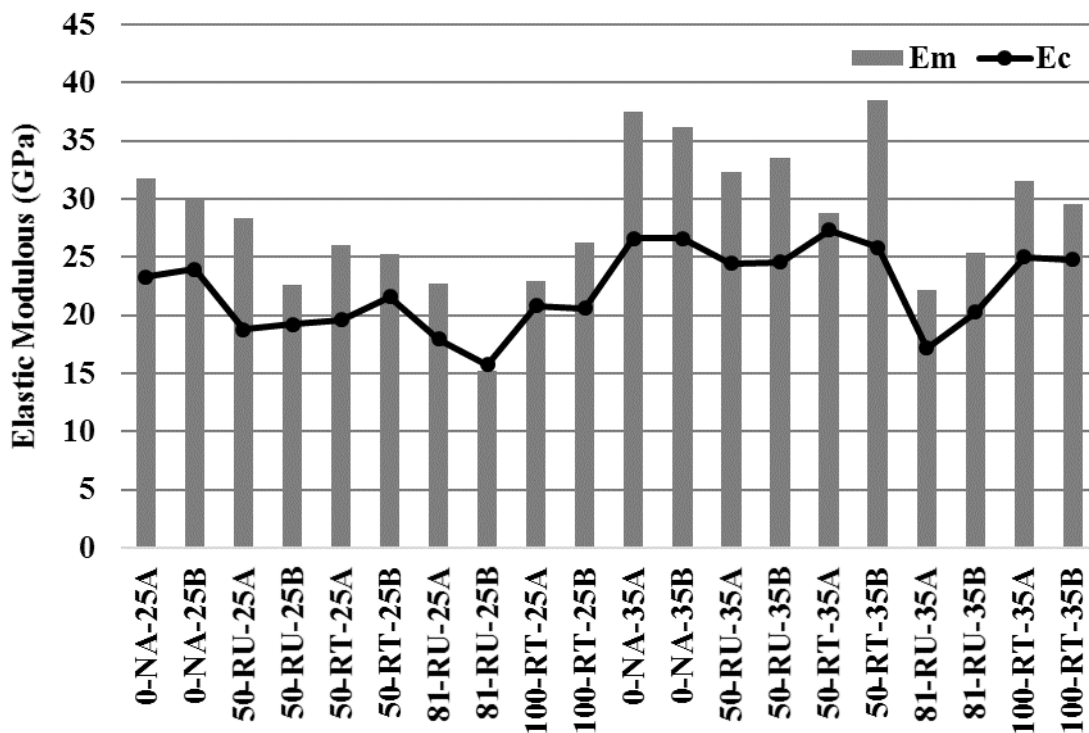

Figure 3-5: Measured Elastic Modulus,  $E_m$ , vs Calculated Elastic Modulus,  $E_c$

### 3.6. Analysis and Discussion

#### 3.6.1. Mechanical Properties of RCA concrete

Some of the reduction in the mechanical properties of the concrete might be attributed to workability issues in the fresh state which could result in improper compaction of the material, especially when the RMC of the RCA was high and thus the amount of fresh mortar low;

however there were also some other underlying issues linked to the RCA microstructure which likely had a considerable effect as well.

While completing the compressive strength tests on the reused material (Source RU) it became clear that initial estimates of the RCA material composition and quality were not accurate. Visual inspection of the broken cylinders revealed that much more of the Source-RU RCA material was comprised of *asphalt* than was initially accounted for. It is estimated that at least  $\approx 30\%$  of this RCA is asphalt, as shown in Figure 3-6.

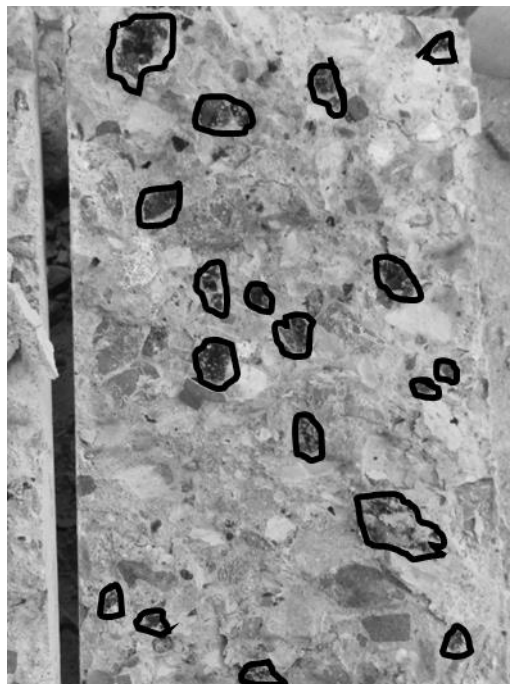

**Figure 3-6: Cross section of an RCA cylinder highlighting the location of embedded asphalt**

This not only impacts the compressive strength of the material, given the lower mechanical properties of asphalt, but also introduces errors in the determination of the residual mortar content. Asphalt will dissolve in the sodium sulphate solution used to remove the residual mortar from the RCA samples, skewing the results of this test and thus the design of the mixes using this source material. Hence, the Source-RU mixes cannot be considered as equivalent mixtures to the control samples. This result further underscores the importance of quality

control practices when sourcing RCA materials for structural concrete.

In this context, in order to fully understand the results presented in the previous section, there is a need to characterize the RCA mechanism of failure in compression, studying mixes presenting different aggregate types, RMC amounts & qualities as well as mechanical properties with more in-depth microscopic analyses and mechanical testing. Although quite preliminary, a visual analysis was performed on the RCA cylinders tested in compression. Observing the cracking patterns within the cylinders tested, there is a potential indication of why the strength results were slightly lower than conventional concrete, which could be directly linked to the quality of the RCA source. Cracks in the cylinders were found to develop within the OVA of the RCA instead of developing at the ITZs and propagating around the aggregate. Figure 3-7 shows a cylinder from batch 100-RT-25A with a large crack having formed in the mortar and continuing through the RCA, directly across the OVA. With this type of failure, it is clear that further research needs to be developed to better understand the impact that the quality of the RCA source will have on the overall performance of the recycled concrete it produces. This indicates that a limiting factor with respect to the use of RCA concrete would be the quality of the RCA source and not only the mix-design (especially in eco-efficient mixes with relatively low cement contents).



**Figure 3-7: Crushed RCA Cylinder showing cracks within RCA**

### **3.6.2. Mix Optimization**

The EMV method employed in this study effectively increased the cement efficiency of the mix designs through the use of RCA, but further optimization was required to produce consistent and predictable results with sufficient strength for structural applications. Abrams law is the widely-accepted equation used to predict the compressive strength of conventional concrete mixtures based on its w/c ratio [109]. It basically states that w/c ratio (or porosity) is the main parameter that influences the mechanical properties of hardened conventional concrete. Although quite accepted for conventional concrete, the results presented in the *Results section* seem to indicate that changes should be made in the Abrams equation in order to account for RCA quality and failure pattern (i.e. Figure 3-7). Abrams Law for the control mixes, both 25 MPa and 35 MPa, can be well defined by the following empirical formula for cylinder strength at 28 days:

$$f'_{c,NA} = 96.6 \cdot 8.2^{-(w/c)} \text{ (MPa)} \quad (3-11)$$

The cylinders with RCA at all the w/c ratios tested were lower than the expected values, much likely due to the different microstructure and crack pattern found for RCA mixes as previously discussed, which indicates that the same Abrams law cannot be directly applied to RCA mixes. In an attempt to develop a similar curve for the RCA concrete, two additional batches of cylinders were cast with 100% Source-RT RCA, with the w/c ratio reduced from 0.47 to 0.45. Further study of the Source-RU RCA was not conducted due to concerns over the material's composition, as mentioned earlier. Furthermore, the decision was made to focus on achieving a mix design of at least 35 MPa, with the reasoning that it would be possible to increase the w/c ratio with the correct equation to achieve a 25 MPa concrete. An optimized mix, 100-RTO-35, mix A and B, was a modification to the 100% Source-RT batch at 35 MPa, with slightly higher cement contents for improve overall workability and a reduced w/c ratio. Complete mix designs for these additional batches are provided in Table 3-5. Both saw an increase in the overall strength due to the lower w/c ratio (31.9 MPa on average versus 30.4 MPa for the concrete with w/c=0.45), however they were lower than the 35 MPa target, leaving room for further improvement. The fresh state behaviour of both mixes, was also highly improved, especially mix 35B.

**Table 3-5: Modified RCA Mix Designs**

<b>Batch</b>	<b>Cement, kg/m<sup>3</sup></b>	<b>Fines, kg/m<sup>3</sup></b>	<b>RCA, kg/m<sup>3</sup></b>	<b>Natural Aggregates, kg/m<sup>3</sup></b>	<b>Water, kg/m<sup>3</sup></b>	<b>w/c</b>
<b>100-RTO-35A</b>	277	614	1416	0	125	0.45
<b>100-RTO-35B</b>	322	521	1416	0	191	0.45

The compressive strength results can be plotted as a function of w/c ratio to allow for a curve to be fit through the data points (Figure 3-8). Maintaining the same format for Abrams Law,  $A * B^{-w/c}$ , the empirical parameters A and B were varied to achieve a curve of best fit for the RCA mixes. The curve provides the following equation which can be used to predict the strength of

RCA concrete mix designs based on a given w/c ratio.

$$f'_{c, \text{RCA}} = 103.4 \cdot 13.4^{-(w/c)} \text{ (MPa)} \quad (R^2 = 0.67) \quad (3-12)$$

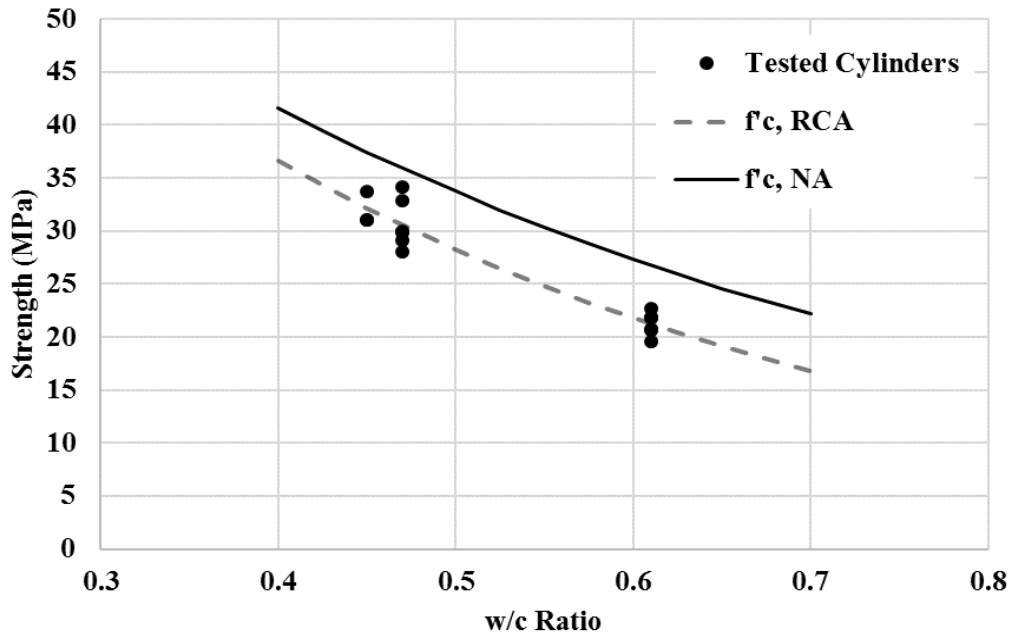

**Figure 3-8: Comparisons of Abrams Law and a modified Abrams Law for RCA concrete**

The applicability of this equation to other sources of RCA, including the Source-RU RCA, is still unknown. However, this finding does suggest that to obtain an optimized mix with a strength equal to the control mix, RCA low cement content mixtures must utilize a reduced w/c ratio (in this case, a w/c ratio of 0.42 would provide a predicted 28-day compressive strength of 35 MPa). Reduction of the w/c ratio will help improve the mechanical properties of RCA mixtures, especially compressive strength, however it will only contribute further to the issues that were experienced with the workability of the material if the cement content remains constant. To address this issue, the volume and proportioning of the new mortar should be reassessed.

The EMV method is restricted in the way that new mortar is proportioned. The ratio of sand and cement in the new mortar is defined by the same ratio as the control mix. The volume of

solid material increases with the use of RCA (as the residual mortar can be considered as a coarse aggregate in the fresh state, but also a mortar in the hardened state) and the consistency of the control mortar may not be suitable for such a large volume of coarse aggregates at high replacement ratios. Decreasing the amount of sand and increasing the amount of cement keeping the same amount of mortar (i.e. cement + sand + water) will help improve the fresh state overall behaviour (i.e. decrease consistency) of the mixture, but decreases its overall efficiency. To alleviate this issue, a modification is proposed to the EMV method to allow the designer more control over the ratio of constituents in the mortar.

The initial procedure for the modified EMV (M-EMV) method is the same as described by Equations 3-1 through 3-7. However, the mortar proportions may be modified to improve the performance of the concrete in the fresh state, since low cement content mixes designed with the conventional EMV method were found to have issues with workability with the new mortar being unable to fully embed the coarse aggregates. To overcome this issue the M-EMV calculates the required weights of fine aggregate and cement as a function of the desired ratio of the specific volumes of cement and sand, represented by  $\psi$ . The designer is then able to specify the value of  $\psi$  needed to achieve a workable mix for a given application. Defining the inverse of bulk specific gravity as  $\beta$ , the volume and mass of cement in the RCA mix can be calculated.

$$\beta_c = 1/SG_c ; \beta_{FA} = 1/SG_{FA} \quad (3-13); (3-14)$$

$$V_c^{RCA} = V_c^{NAC} - V_{RM}^{RCA} * \beta_c / (\beta_c + \psi \beta_{FA}) \quad (3-15)$$

$$W_w^{RCA} = V_c^{RCA} * SG_{RCA} * (w/c) \quad (3-16)$$

with w/c being specified, keeping in the mind the recommended modifications to Abrams law presented earlier in this paper as Equation (3-12).

Having calculated the volume of all other components, the remaining volume of materials in a unit of RCA concrete must be comprised of either air or fine aggregates. If the air content ( $V_A^{RCA}$ ) is specified by the designer, then the volume of fine aggregates in the RCA mix is as follows:

$$V_{FA}^{RCA} = 1 - V_C^{RCA} - V_W^{RCA} - V_A^{RCA} - V_{NA}^{RCA} - V_{RCA}^{RCA} \quad (3-17)$$

Increasing parameter  $\psi$  increases the volume of cement in the mix and decreases the volume of sand. By doing so the consistency of the mortar is improved without the addition of admixtures. The drawback to this choice is that increasing this parameter also reduces the cement efficiency if there is no increase in strength.

Combining both of these design modifications, a new optimized mix design was developed. Starting with a new control mix (0-NA2-35) containing 400 kg/m<sup>3</sup> of cement, a new RCA mix with 100% replacement, 100-RTM-35 was developed and fabricated. A control mix with a slightly higher cement content was selected as another strategy of increasing the workability of the concrete in the fresh state. The predicted strength of this control mix without RCA was 39.5 MPa using a w/c ratio of 0.42. Details for this mix are provided in Table 3-6.

**Table 3-6: Optimized RCA Mix Design**

<b>Batch</b>	<b>Cement, kg/m<sup>3</sup></b>	<b>Fines, kg/m<sup>3</sup></b>	<b>R-CA, kg/m<sup>3</sup></b>	<b>Natural CA, kg/m<sup>3</sup></b>	<b>Water, kg/m<sup>3</sup></b>	<b>w/c</b>
<b>0-NA2-35</b>	400	723	0	1056	180	0.42
<b>100-RTM-35</b>	322	547	1416	0	135	0.42

Although the cement content for mix 100-RTM-35 is higher than many of the other mixes developed as part of this study at 322 kg/m<sup>3</sup>, this still corresponds to a 19.5% reduction in the amount of cement used compared to the control mix. Parameter  $\psi$  was set to 6 (relating the unit volume of sand to the unit volume of cement), which provided a mortar with the appropriate consistency to allow cylinders to be adequately vibrated and for enough of the voids to be removed, despite still only having a slump of  $\approx 1.0$  cm. The control concrete in this

study had  $\psi = 3.5$ , and values from 3 to 4 are typical of traditional concrete. In a repair mortar where more flowability is valued sand is omitted in favour of more cement (and water to obtain a consistent w/c ratio) and  $\psi = 8$  to 10 is common.  $\psi = 6$  was selected knowing that the desired behaviour of the mortar for the RCA concrete was somewhere in between a traditional concrete mortar and a repair mortar. Figure 3-9 shows the results of the compressive strength tests conducted at 7, 14 and 28 days for two batches made from this material.

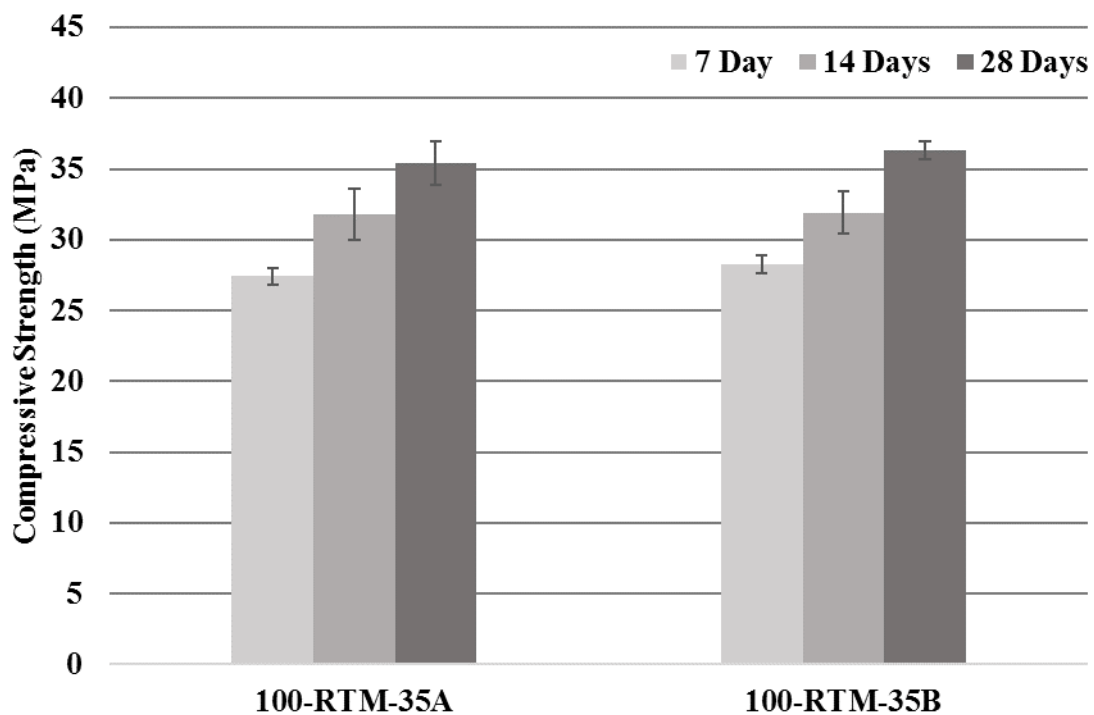

**Figure 3-9: Compressive Strengths of 35MPa Concrete Made with a Modified EMV**

The average strength of the concrete from both batches was greater than the 35 MPa target strength at 28 days. The modulus of elasticity was found to be 35.2 GPa, exceeding the value of 26.7 GPa calculated by CSA 23.3 based on the cylinder strength at 28 days. The tensile splitting strength was measured as 3.01 MPa, which is predictable based on the modulus of rupture calculated to be 3.61 MPa, again based on the equations provided by CSA A23.3. In addition to achieving all of the desired targets, the methods used to optimize this mix design reduced the standard deviation significantly, indicating that this mix design is duplicable and

able to produce consistent results that regularly meet performance requirements.

### 3.6.3. Cement Efficiency

It is a common misconception that a decrease in the amount of cement in a concrete design will result in a lower strength material. Many studies have shown that this is not true and that scientific design methods exist (e.g. particle packing models) to help reduce the content of cement and alternative binders within concrete and improve the cement efficiency of the material [2]. Binder efficiency may be measured using a parameter known as the binder intensity ( $bi$ ). (In the case of the concrete mixes presented in this study, the cement efficiency and binder efficiency are the same as no SCMs were used as part of this project.) Binder intensity is calculated by dividing the weight of binders per cubic meter of concrete ( $\text{kg/m}^3$ ) by a targeted performance indicator such as compressive strength. In other words, it is the amount of cement used to achieve 1 unit of a targeted property, such as 1 MPa of compressive strength in this case.

Comparing the  $bi$  factor for the EMV mixes can be done in one of two ways, the theoretical  $bi$  factor, based on target strength, and the actual  $bi$  factor, based on the measured average strength. Although some of the initial mixes did fail to meet target strengths, for many of them the mixes were still usable, provided that the weaker strength is accounted for, and it is possible that with optimization of workability through adjustments in mortar consistency and  $w/c$  ratio that target strengths could be met. Binder efficiencies for each of the mix designs are shown Table 3-7. Two separate  $bis$  are provided for each mix, first the  $bi_{\text{pred}}$ , the value that would hold true had the cylinders met their target strengths. The second,  $bi_{\text{meas}}$ , is the binder intensity based on the average measured compressive strength at 28-days, which seems to be a more accurate indicator of binder efficiency in this case.

For good cement efficiency, it is preferable to maintain a  $bi$  of less than  $10 \text{ kg/m}^3 \cdot \text{MPa}^{-1}$  [2].

Achieving this target with high strength concretes is often feasible because the additional strength achieved helps to reduce the value [2]. Otherwise, in CC (i.e. 25-35 MPa), especially for 25 MPa mixes, achieving a lower  $b_i$  may be extremely difficult. In cases where higher cement efficiency is observed it is often the result of replacing cement with a combination of SCMs, such as fly ash and silica fume [2]. It has been observed that for concrete with a strength of 20 MPa the minimum  $b_i$  is approximately  $13 \text{ kg/m}^3 \cdot \text{MPa}^{-1}$  [2]. Theoretically, all of the RCA mixes were able to reach the target of  $10 \text{ kg/m}^3 \cdot \text{MPa}^{-1}$ , however once corrected for strength loss, the true  $b_i$  factor could end up higher than that of the target value. The 35MPa target strength mixes performed very well by this matrix, even when corrected, as would be expected for concretes with an increased strength. The optimized concrete mix design has a predicted  $b_i$  of  $9.2 \text{ kg/m}^3 \cdot \text{MPa}^{-1}$ , keeping it below the desired value of  $10 \text{ kg/m}^3 \cdot \text{MPa}^{-1}$  without compromising on strength and other mechanical properties.

When referring to eco-sustainability, the  $b_i$  provides a simple quantitative term for comparison, but there does not currently exist a simple term that combines both the environmental sustainability associated with a reduction of cement and the use of recycled materials over new natural aggregates. Further areas of research might include a more in depth analysis to estimate the  $\text{CO}_2$  intensity ( $c_i$ ) of these concretes. Similar to  $b_i$ ,  $c_i$  compares the amount of  $\text{CO}_2$  produced in the production and transportation of raw materials per unit of strength achieved by the concrete [2]. RCA performs favourably in this category because not only does it reduce the demand for cement, it also reduces the emissions required to produce new coarse aggregate and in many cases needs to be transported a shorter distance than new coarse aggregates. Furthermore, the reduction of waste material is an additional environmental benefit of RCA. Without going into a more detailed analysis, it is still clear that the impact of all these factors is not insignificant. Further development of these mixes to include SCMs and admixtures has the potential to reduce the  $b_i$  and  $c_i$  even more. The mixes studied for this project are the first

step in the development of a mix-design that combines multiple elements to be holistically eco-efficient.

**Table 3-7: Binder Intensity of RCA Concretes**

<b>Mix Design</b>	<b>Cement Content (kg/m<sup>3</sup>)</b>	<b>Average Compressive Strength (MPa)</b>	<b>BI<sub>pred</sub> (kg/m<sup>3</sup>·MPa<sup>-1</sup>)</b>	<b>BI<sub>meas</sub> (kg/m<sup>3</sup>·MPa<sup>-1</sup>)</b>
<b>0-NA-25A</b>	314	25	12.6	12.6
<b>0-NA-25B</b>	314	25	12.6	12.6
<b>50-RU-25A</b>	220	17.46	8.8	12.6
<b>50-RU-25B</b>	220	18.24	8.8	12.1
<b>50-RT-25A</b>	264	18.99	10.6	13.9
<b>50-RT-25B</b>	264	23	10.6	11.5
<b>81-RU-25A</b>	162	15.96	6.5	10.2
<b>81-RU-25B</b>	219	12.26	8.8	17.9
<b>100-RT-25A</b>	215	21.41	8.6	10.0
<b>100-RT-25B</b>	215	21.01	8.6	10.2
<b>0-NA-35A</b>	370	35.0	10.6	10.6
<b>0-NA-35B</b>	370	35.0	10.6	10.6
<b>50-RU-35A</b>	260	29.6	7.4	8.8
<b>50-RU-35B</b>	260	29.8	7.4	8.7
<b>50-RT-35A</b>	312	36.9	8.9	8.5
<b>50-RT-35B</b>	312	33.0	8.9	9.5
<b>81-RU-35A</b>	191	14.6	5.5	13.1
<b>81-RU-35B</b>	250	20.3	7.1	12.3
<b>100-RT-35A</b>	254	30.9	7.3	8.2
<b>100-RT-35B</b>	254	30.4	7.3	8.3
<b>100-RTM-35A</b>	322	35.4	9.2	9.1
<b>100-RTM-35A</b>	322	36.33	9.2	8.9

### 3.7. Conclusions

Based on the research conducted on the mechanical performance of RCA concrete, the following conclusions can be made:

1. Use of the EMV method allows for the new cement and mortar content of a concrete mix design to be reduced by taking into account the contribution that adhered mortar on the RCA has on the total cement demand of the mix. This method allowed for the

cement content to be reduced from 314 kg/m<sup>3</sup> and 370 kg/m<sup>3</sup> for the control mixes to as low as 162 kg/m<sup>3</sup> and 191 kg/m<sup>3</sup> for mixes with RCA, for targeted strengths of 25MPa and 35MPa, respectively.

2. For a concrete with a lower mortar content, the quality of the RCA source has a significant role in the quality of the final product. RCA containing significant amounts of undesirable material (asphalt, clay brick etc.) will reduce the strength and stiffness of the concrete.
3. Even in cases where the RCA concrete failed to meet the design strength, the strength that was achieved can accurately be used to estimate the elastic modulus of the concrete of the material using design equations. Modulus of rupture is less predictable when non-concrete aggregates are present.
4. A modified Abrams Law is recommended for use with RCA concretes. Findings suggest that in order to achieve comparable strength to the control mix, RCA concretes with low cement content must utilize a lower w/c ratio. The new equation developed in the project was able to accurately predict the w/c ratio of 0.42 needed to reach 35 MPa with 100% RCA replacement. The applicability of this specific equation to other sources of RCA is unknown and a modified Abrams law may need to be calculated for each RCA source for the most accurate results.
5. Modification of mix proportions through a modified EMV method is one solution to improve the consistency and workability of RCA. Strategically increasing the volume of cement and decreasing the volume of fine aggregates can significantly reduce the viscosity of the mortar so that it is able to more uniformly cover the RCA particles.
6. Combining the modifications to the w/c ratio and cement contents, a 35MPa mix was optimized, with 322 kg/m<sup>3</sup> of cement, corresponding to a 19.5% decrease in the mass of cement and a bi lower than 10 ( 9.2 kg/m<sup>3</sup>•MPa<sup>-1</sup>).

7. Microscopic and further analyses are still required in order to understand how RCA microstructure governs the mechanism of concrete in its fresh and hardened states.

## **4. Investigation of Structural Behaviour**

### **4.1. Introduction**

Following the optimization process developed in Chapter 3, the best performing mix designs with 35 MPa compressive strength were used to fabricate a series of six reinforced concrete beams to further evaluate their use for structural applications. Although many researchers have reported inferior structural behaviour of reinforced concrete elements containing large proportions of RCA, previous research has also shown that concrete beams proportioned according to the EMV method can perform similarly to companion beams made with natural aggregates in terms of flexural stiffness, shear, and moment capacity [23–25,35]. Therefore, to validate the use of the mix designs presented in Chapter 3, one of the objectives of the beam tests was to compare the performance of beams made with 0, 50, and 100% RCA replacement of natural coarse aggregates in terms of their load-deflection response and ultimate capacity in shear and flexure.

While several studies are available in the literature describing the overall structural behaviour of concrete beams with RCA, relatively little focus has been placed on the effect of RCA properties on the development and propagation of cracks; hence, one motivation for this study was to compare the overall distribution of cracks (i.e. spacing and number of cracks) of beams with different amounts of coarse RCA, and to observe the effects of residual mortar and particular microstructure of crushed RCA on crack propagation.

It is well-known that in conventional concrete, cracks tend to propagate through the interfacial transition zone (ITZ) between aggregates and mortar, thus creating an uneven cracked surface which helps to prevent relative transverse displacement (i.e. sliding) between the two faces of the crack known as aggregate interlock. In the case of RCA concrete, multiple ITZs exist between the original aggregate and residual mortar, original aggregate and new mortar, and

between the old and new mortar. Furthermore, if the grading of RCA particles is consistent with that of natural aggregates in a reference mix, the actual size of the original aggregate particles may be considerably smaller and it is unclear how this difference in particle size combined with the adhered mortar will impact the fracture mechanics of the RCA concrete. Finally, as observed in the results of Chapter 3, pre-existing defects in RCA particles (likely induced during the crushing process) may reduce the energy required for a crack to propagate through an aggregate rather than around it, possibly resulting in a less uneven crack surface. It seems likely, therefore, that both the kinetics (crack propagation) and kinematics (crack sliding) of a cracked reinforced concrete beam may be linked to the quantity and quality of an RCA material used.

It is also worth mentioning that some researchers have also reported a reduction in bond stiffness and bond strength in the case of steel reinforcing bars embedded in RCA concrete [110,111]. This would likely result in a reduction in tension stiffening behaviour as well as an increase in crack widths and spacing. The intricacies of this are outside the scope of this analysis, but provide an interesting basis for future studies.

#### **4.2. Beam Design**

A total of six beams were designed for this study. All beams were designed in accordance with CSA A23.3-14. Three mix designs were used as previously presented in Chapter 3 for the returned concrete source (RCA-RT) having a specified 28-day compressive strength of 35 MPa and having suitable fresh state properties (0-NA-35, 50-RT-35 and 100-RTO-35). A testing matrix for the investigation is provided in Table 4-1.

**Table 4-1: Testing Matrix**

<b>Mix Design</b>	<b>Flexural Controlled</b>	<b>Shear Controlled</b>
<b>Control</b>	NA-FL	NA-S
<b>50% RCA</b>	50-FL	50-S
<b>100% RCA</b>	100-FL	100-S

The volume of the mixer and equipment available governed the volume of the beams, as a result each beam was cast with a single batch of concrete. The actual compressive strength of each mix at 28-days and the time of testing is given in Table 4-2.

**Table 4-2: Concrete Strength at Time of Testing**

<b>Beam</b>	<b>28 Day Strength (MPa)</b>	<b>Test Day Strength (MPa)</b>	<b>Age at Testing (Days)</b>
<b>NA-FL</b>	35.5	35.9	99
<b>NA-S</b>	35.4	36.2	100
<b>50-FL</b>	35.2	36.3	99
<b>50-S</b>	35.2	36.1	98
<b>100-FL</b>	35.4	35.2	72
<b>100-S</b>	36.3	38.8	72

While the slump for the control mix was 10 cm (as expected), the slumps of the each of the RCA mixes was lower, at 6 cm and 3 cm for 50% and 100% RCA mixes, respectively. Despite this, the concrete was workable and was placed easily with a rod vibrator. With the 100% RCA mix, achieving a smooth trowel finish on the top of the beams was more difficult than for the control mix because of the smaller quantity of new mortar. One beam for each mix was designed to achieve a flexural failure by placing transverse reinforcement along the length of the beam at a spacing of 200 mm. An additional beam for each mix was designed to force a shear failure to occur on one end of the beam. Stirrups were intentionally removed from one side of the shear beams so that the location of the critical shear crack was known. All beams

had the same longitudinal reinforcement: two 20M bars as tension reinforcement and a single 10M bar for compressive reinforcement, provided primarily to support the stirrups. The cross section was kept consistent across all beams at 150mm x 350mm. 10M closed stirrups were spaced at 200 mm in either one or both shear spans, depending on the failure mode that was being targeted. A beam cross section is shown in Figure 4-3.

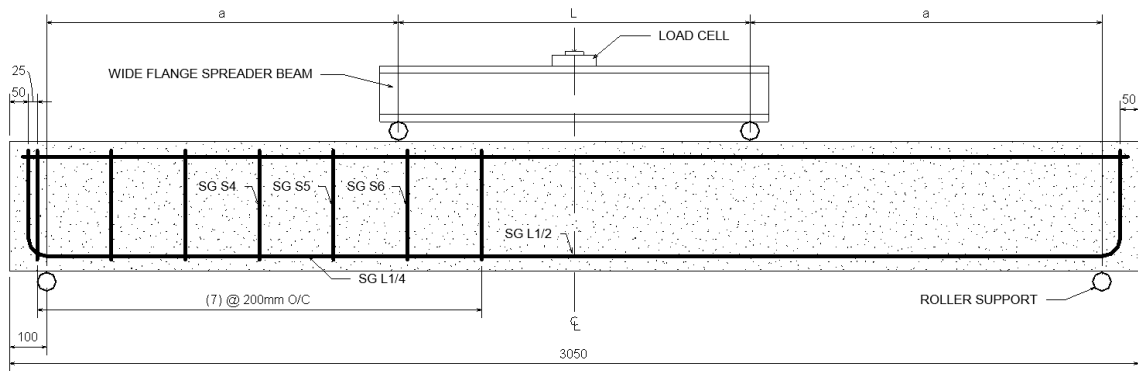

**Figure 4-1: Shear Failure Beam Design**

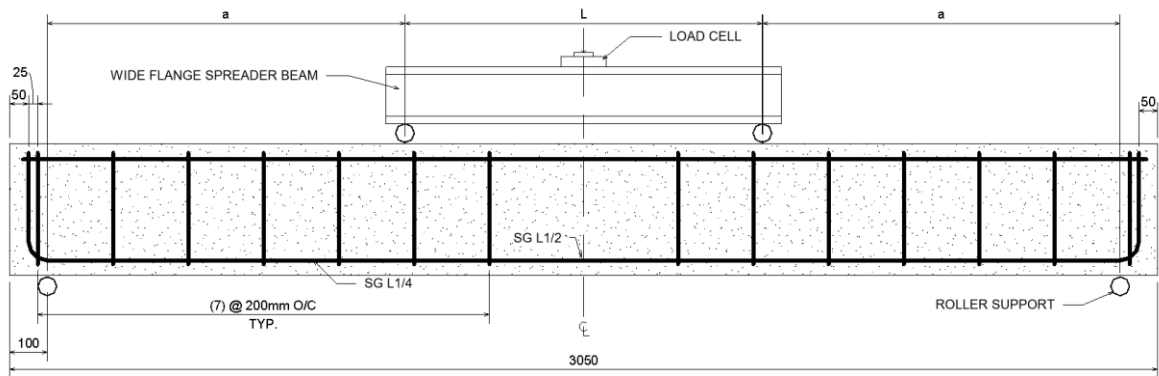
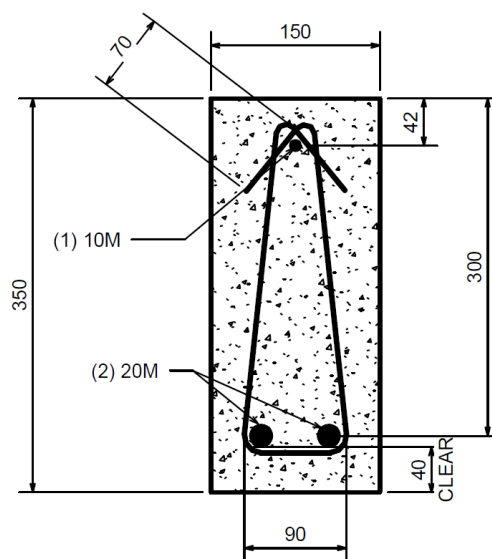

**Figure 4-2: Flexural Failure Beam Design**

**Table 4-3: Beam Design Data**

<b>Beam</b>	<b>Zero Moment Region Length, L (mm)</b>
<b>NA-FL</b>	950
<b>50-FL</b>	950
<b>100-FL</b>	900
<b>NA-S</b>	950
<b>50-S</b>	750
<b>100-S</b>	950

50-S was the first of the beams to be tested in the lab. The results of the test were not as expected with the beam ultimately failing in flexure by yielding of the steel reinforcement followed by concrete crushing in compression. Subsequently, the test setup was modified to increase the length of the zero-moment region from 750 mm to 950 mm (reducing the shear span length from 1050 mm to 950 mm) with the goal of increasing the predicted failure load for flexure and allowing for a shear failure to be achieved where desired, as highlighted in Table 4-3. In the case of the 100-FL specimen, the loading point locations were slightly modified to avoid interfering with the hoisting hooks placed in the top of the beam.



**Figure 4-3: Beam Cross-section and Stirrup Design**

### 4.3. Test Setup and Instrumentation

Electrical resistance strain gauges were used to measure the strain in the reinforcing steel. The strain gauges were placed as shown in Figure 4-1 and Figure 4-2. Two cable extension linear position transducers were placed to record mid-span displacement of the beams.

All beams were tested in four-point bending and roller assemblies were used to transfer load from a spreader beam to the tested beam and at the beam support points. The spreader beam was placed symmetrically about the centreline of the beam. Load was applied to the beam using a manual pump and one data point was recorded every second. Strain and load measurements were recorded once per second.

### 4.4. Experimental Results

The results of the beam tests are shown below. The cracking moment for the beams was calculated to be 10.9 kNm, with a yield moment of 65 kNm for the flexural beams and a calculated unfactored shear capacity of 51 kN for the beams without stirrups, according to the General Method described in the CSA A23.3 design code. The service load was taken as 30 kN, which is approximately 40% of the maximum predicted flexural capacity of the beams. Experimental  $M_{cr}$  values were determined based on changes in the stiffness observed in the load-deflection curve for each of the beams. Table 4-4 summarizes the results of the beam tests and compares them to the design values for the members. Figure 4-4 shows the beams at failure.

**Table 4-4: Beam Performance**

Beam	$M_{cr}$ (kNm)	$M_y$ (kNm)	$\frac{M_y}{M_{pred}}$	$\delta_{service}$ (mm)	Beam	$M_{cr}$ (kNm)	$V_u$ (kN)	$\frac{V_u}{V_{pred}}$	$\delta_{service}$ (mm)
NA-FL	14.3	67.1	1.03	4.55	NA-S	11.9	52.6	1.02	5.77
50-FL	9.5	68.2	1.04	4.84	50-S	10.5	65.4	1.25 <sup>1</sup>	6.22
100-FL	9.5	66.7	1.02	4.35	100-S	9.5	45.9	0.85	5.95

1. This beam experienced a flexural failure, with yielding of the steel and not a shear failure as predicted.

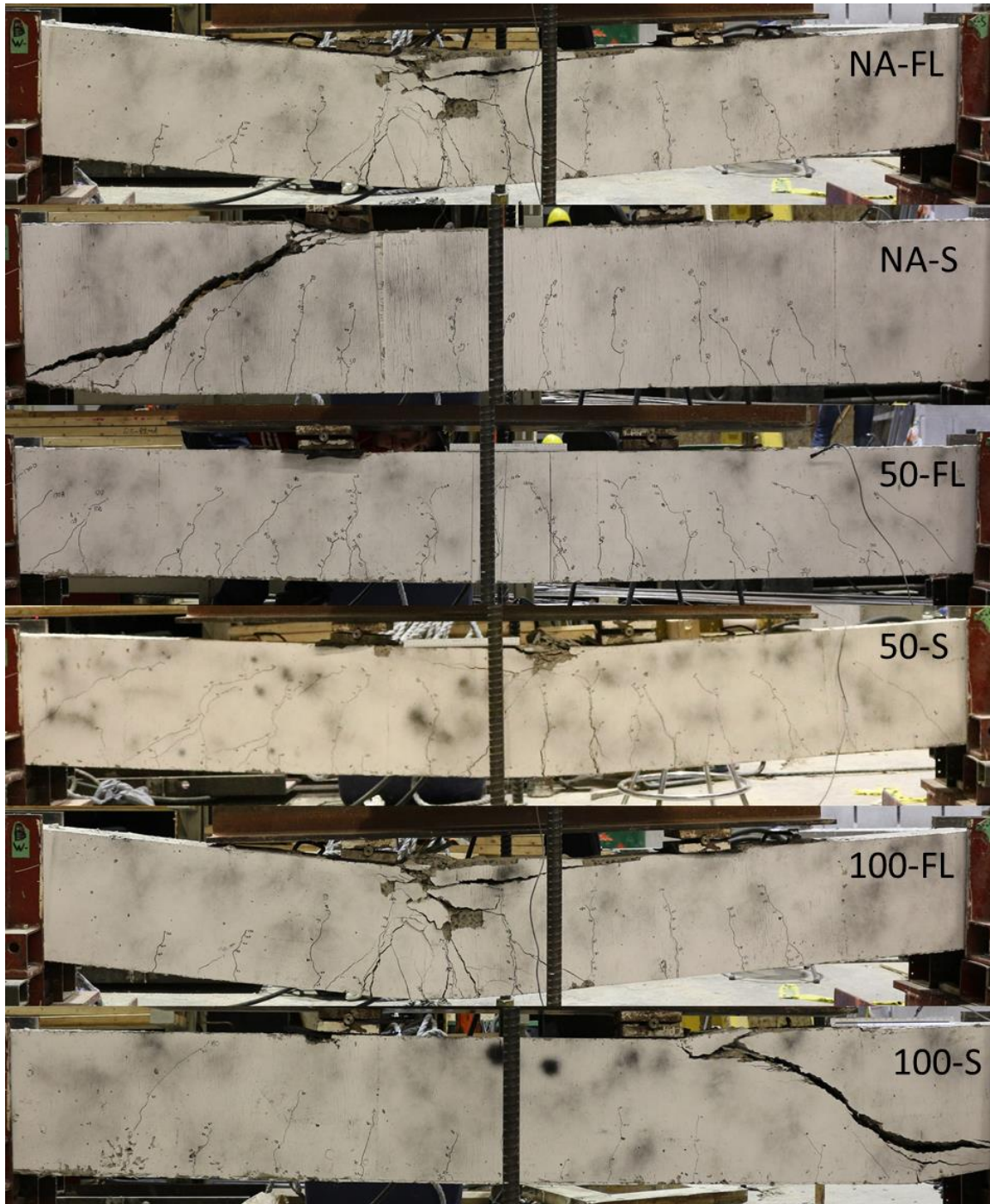

**Figure 4-4: Images of each test beam at failure**

\*Beam 50-FL is shown photographed shortly before failure. This beam was tested well beyond yielding of the steel and in the final state the beam fell out of the testing apparatus and making photography for comparison difficult.

The load-deflection curves for the beams are provided in Figure 4-5 for the beams designed to fail in flexure, and Figure 4-6 for the beams designed to fail in shear. One interesting observation from the test results is that the 50% RCA beam designed to fail in shear exceeded

the shear capacity of the beam, as designed according CSA A23.3-14, and ultimately failed in flexure, at the predicted flexural capacity. Both the control beam and the beam with 100% RCA replacement without transverse stirrups failed in shear as expected. The 100% RCA beam designed for a shear failure did not reach the predicted shear capacity or that of the control member despite the cylinders from the same batch having the highest average compressive strength overall. Potential explanations for this result are presented in the following section of this chapter.

The cracking moment in the RCA beams was consistent among all the beam tests at approximately 9.5 kNm, slightly lower than the predicted cracking moment and the cracking moment of the control members. At service conditions, the cracks in each of the beams had stabilized and although there is some variability in crack spacing, the average crack spacing length does not seem to be correlated to the amount of RCA used or the lower cement contents (Table 4-5).

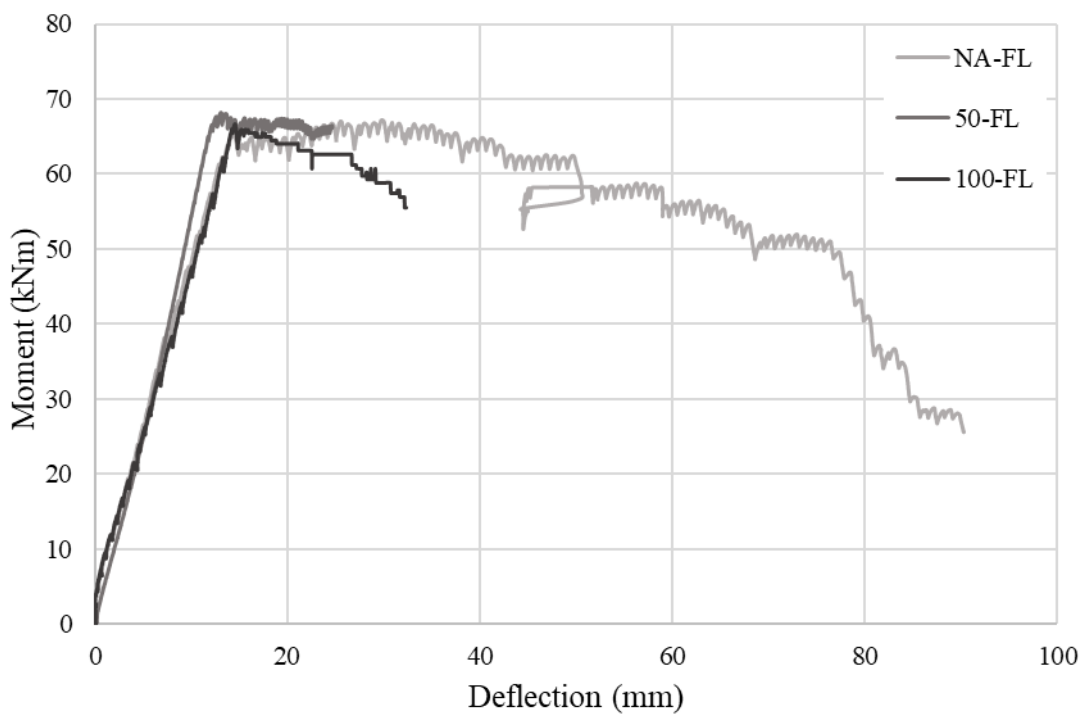

**Figure 4-5: Flexural Beam Load-Deflection Curves**

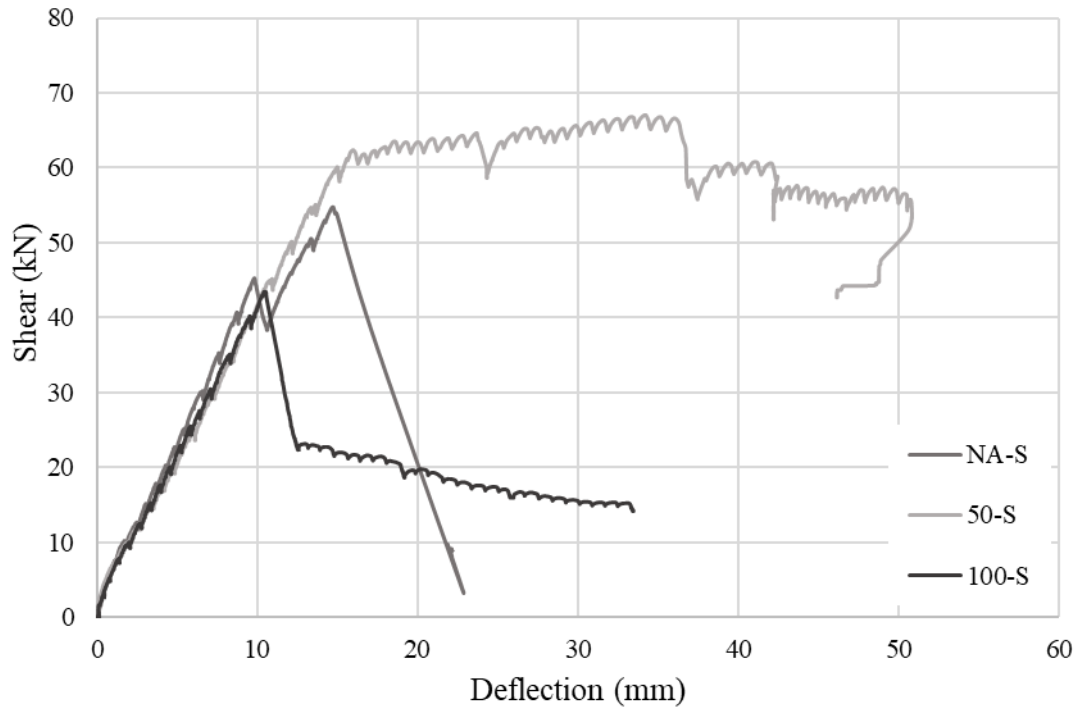

**Figure 4-6: Shear Beam Load-Deflection Curves**

**Table 4-5 Crack development at service load**

<b>Beam</b>	<b>Number of cracks</b>	<b>Maximum crack spacing (mm)</b>	<b>Average crack spacing (mm)</b>
<b>NA-FL</b>	6	322	178
<b>50-FL</b>	7	252	178
<b>100-FL</b>	8	355	228
<b>NA-S</b>	8	319	186
<b>50-S</b>	7	269	189
<b>100-S</b>	6	234	194

The midspan deflections of the beams at service did not change significantly between each test, with a maximum variation of 1 mm within each set of test specimens. With each beam spanning a length of 2850 mm, all midspan displacements at service conditions were less than  $L/360$ , corresponding to a displacement of 7.91 mm. Strain gauge data from the beam tests is provided

for reference in Appendix C but this data does not form the basis of any substantial analysis for part of this study.

All of the beams designed to fail in flexure behaved as expected, with yielding of the longitudinal steel reinforcement followed by concrete crushing. The post-yield behaviour of the flexural beams varied somewhat, as the ductility of the members after yielding of the steel appeared to be reduced in the flexure beams that utilized RCA, although there was little difference between the two RCA beams with different replacement levels. However, the beam designed to fail by shear containing 50% RCA ultimately displayed a flexural mode of failure with ductile behaviour, reaching an ultimate displacement of more than 50 mm, which seems to contradict the results obtained from the flexural beams.

The beams designed to fail in shear presented some interesting results. The control beam containing only natural aggregates failed in shear very close to the predicted strength of 51 kN. The beam with 100% replacement by coarse aggregates showed a reduction in shear strength of approximately 15%, which is also not completely surprising given the points previously presented regarding the weaker zones present in the RCA. Most surprising was the result of the beam with 50% replacement of natural coarse aggregates with RCA. This, along with the detailed cracking behaviour of the RCA concrete merits further discussion and is explored in more detail in the following section.

#### **4.5. Discussion**

While the cause of the excess capacity of the shear beam with 50% RCA content is not known with certainty and is based on only one beam sample, an effort is made here to understand some of the mechanisms that contribute to the shear strength of concrete and provide a potential explanation. The discussion points raised in this section should be considered within the

context of this study having a limited sample size, and should not be widely generalized without further study.

Based on the beam tested for flexural failure, the ductility of the RCA concrete appears to be reduced when compared to the control beams. The exact cause of this is unknown without further studies. Knowing that the microstructure of RCA is different than natural aggregate and the way that cracks develop through RCA may be different than traditional aggregates (see discussion later in this section) it is hypothesized that the presence of microcracking or small irregularities in the RCA may allow cracks, and ultimately failure of the concrete, to occur sooner than they would in concrete made with all natural aggregates not exhibiting these same imperfections.

Aggregate interlock is an important factor in the design of concrete for shear strength, and is influenced by the properties of the aggregates, width of the crack, and the geometry of the critical shear failure crack. RCA is different from natural aggregates in that the graded size is not always the same as the actual size of the OVA particles due to the presence of RM. The method of crushing, strength of the original concrete, exposure and age of the material will all impact the shape of particles and quantity of residual mortar. The RCA containing residual mortar behaves as an aggregate in the fresh state but has been shown to behave as a mix of aggregate and mortar in the hardened state; hence, the nominal size of the original aggregate particles present in the RCA will tend to be smaller than the RCA particle itself. The EMV matches the total volume of mortar and coarse aggregates but does not inherently account for any differences in particle size.

The results presented in Chapter 3 also clearly indicated that the failure planes in RCA concrete are not always through the matrix or ITZ as normally expected in the case of conventional concrete made with natural aggregates. Even in cases where the design compressive strength

was achieved, there was evidence of cracking through the original aggregates, an undesirable and more brittle failure mechanism.

Two forensic studies were performed on the tested beams from this study. First, the beams were cut so that the crack faces of the shear failure planes could be exposed and further examined. High resolution photos were taken of the surface and qualitatively assessed. Second, a set of cores were taken perpendicular to some of the cracks in each beam to investigate the crack propagation through and around aggregate particles in each of the three mixes. Locations of the cores are shown in Figure 4-7.

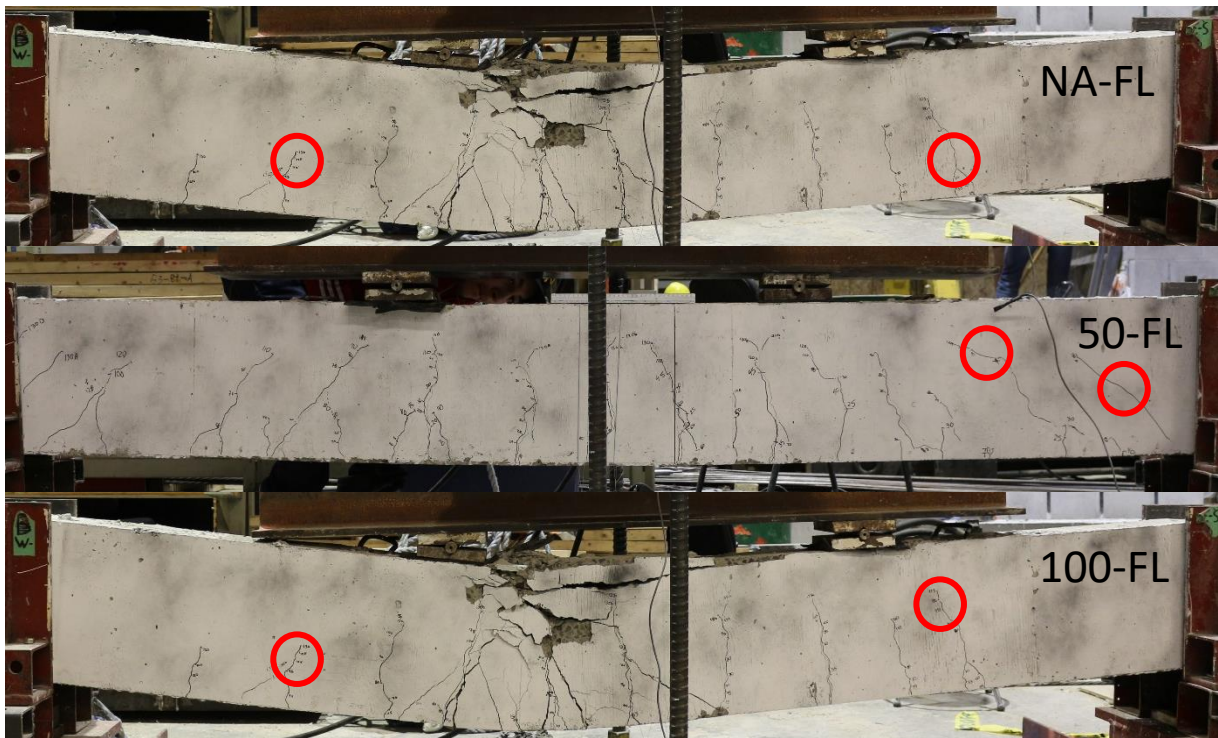

**Figure 4-7: Locations of concrete cores taken in flexure members**



**From left to right: photos of shear failure planes for control, 50% RCA and 100% RCA beams**

**Figure 4-8 – Cracked surfaces with different proportions of coarse RCA**

Visual examination of the shear failure planes (shown in Figure 4-8) of beams from the three mix types were notably different. The control member showed a moderately rough surface, with a large amount of exposed aggregate and pop out where the surfaces of the beam met. The 100% RCA beam had a much smoother surface with a large amount of fracturing in the aggregates. This reduction in surface roughness helps to explain the loss in shear strength despite the concrete mix design having adequate compressive strength. Visually, the surface of the 50% RCA beam appeared to be the roughest. The surface showed that some of aggregates had separated from the new mortar, but the weakest plane appears to be between the adhered mortar on the RCA and the new mortar in the RCA concrete. The increased roughness of the surface would provide more aggregate interlock across the shear plane, which corresponds to the beam failing in flexure well after the predicted shear failure load was reached.

Figure 4-9 shows sample surfaces obtained from concrete cores taken from the beams after testing. The cores were extracted perpendicular to the crack plane and were then cut into discs

and polished. Several interesting observations may be found from comparing these images. First, in the case of the control beams (0% RCA, Figure 4-9a), the crack tends to mostly outline the coarse aggregates through the ITZ, and cracks through the mortar are relatively straight and smooth. This is considered to be a fairly typical case as it follows the general expectations for crack propagation in a conventional concrete mix.

Looking next at the image from the concrete sample with 50% RCA (Figure 4-9b), several things clearly stand out: first, some cracks propagate through the ITZ between the new and old mortar as opposed to the original aggregates and residual mortar, or between the original aggregate and new mortar, suggesting that the weakest interface is found between the RCA and new mortar such that at least in this scenario the RCA may be considered to behave like a natural aggregate in terms of crack mechanics; second, since the mix was designed using the EMV method, less new mortar was added to the concrete mix causing a reduced spacing between the coarse aggregates (which in this case includes the RCA due to the first observation), causing an apparent increase in the tortuosity of the crack path (i.e. unevenness of the crack surface); and third, when an aggregate intercepts the crack in such a way that more energy is needed to propagate the crack around the aggregate than through it, fracture of the aggregate itself is observed. The first observation may possibly be an indication that the older mortar in the RCA, is able to achieve a stronger bond to the original aggregate than is developed in the new ITZ at the interface between the RCA and the new mortar. The first two observations together provide some explanation for the observed increase in shear strength in the beams with 50% RCA. It should be carefully noted once again that these observations are based on only a single qualitative assessment, and that further microscopic analysis is needed to present a more quantitative analysis.

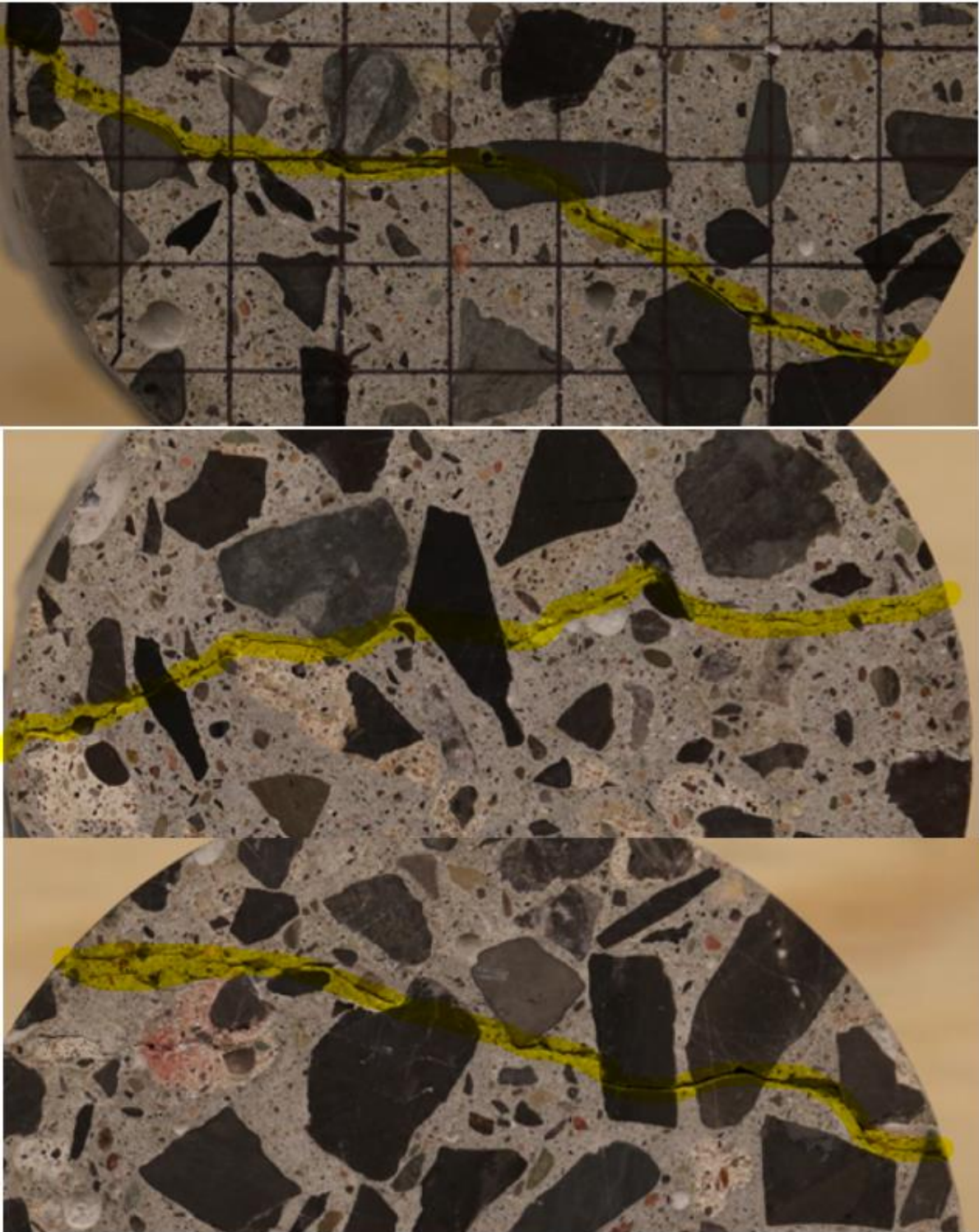

**Figure 4-9 – Polished concrete core surface showing crack propagation. From top to bottom: 0%, 50%, and 100% RCA**

In the case of concrete with 100% RCA (Figure 4-9c), it is observed once again that the spacing between coarse aggregates has reduced when compared to the image of the control specimen. However, in this case, the crack path around the aggregates appears to require too much energy and the crack instead propagates directly through the aggregates leading to a smoother crack surface and hence a reduction in aggregate interlock resulting in the lower shear capacity observed for the beam with 100% RCA.

While very interesting and providing several key insights into the structural behaviour of concrete made with RCA, it is important to note that these results are quite preliminary and additional work is needed to verify and better understand the results.

#### **4.6. Summary**

Through the study of reduced cement content RCA concrete as a structural material, there are several observations that can be made based on the test results.

The flexural capacity of members made with the reduced cement content RCA concrete was comparable to control members tested. The behaviour of the members prior to yielding of the reinforcement was predictable when designed in accordance with CSA A23.3-14. The post-yielding behaviour of the members was less predictable, with only one test member having similar behaviour to the control. The capacity of the under-reinforced members does not appear to be correlated to the replacement percentage with RCA.

The shear capacity of the RCA, although comparable to the capacity of the control members, was less predictable than the flexural capacity. The control member had a failure as calculated using the general method of CSA A23.3-14, while the 50% RCA member unexpectedly failed in flexure, and the 100% RCA member failed at 85% of the calculated capacity. Visual inspections of the shear failure planes and polished cores showed that each of the concrete mixes showed different paths for crack development. The increased tortuosity of the crack path

in the 50% RCA sample helps explain the increase in shear strength of the members, but in the case of 100% RCA replacement, the closely spaced aggregates resulted in a lower energy demand for aggregate fracture than for the cracks to travel around the aggregate ITZ. From these preliminary results, it seems that while the presence of RCA may indeed have a non-negligible effect on aggregate interlock and shear capacity, the properties of the RCA and the aggregate packing structure both play an important role and further research is needed to understand this phenomenon more clearly.

## 5. Conclusions

The intent of this research was to develop and study a reduced cement content RCA concrete with the goal of establishing a mix design with sufficient material and mechanical properties for structural applications. In recent years, the construction industry has begun to focus more and more on environmentally sustainable alternatives to traditional materials. Often these alternatives come with an increased cost to manufacturers. RCA is a low cost, readily available alternative to traditional natural aggregates. For RCA concrete to be adopted for use in the construction industry it needs to be well understood, with predictable properties, comparable to the material it is replacing. It is also vital that the benefits of using RCA not be offset by the inclusion of additional cement or admixtures which can undermine benefits to the environment and any cost savings. The research presented in this study with reduced cement content RCA concrete suggests that it is possible to produce a viable material for structural use when the correct design procedure and testing is used.

Use of the EMV method allows for the new cement and mortar content of a concrete mix design to be reduced by considering the contribution that adhered mortar on the RCA has on the total cement demand of the mix. Ideally, the additional testing required for RCA when compared to natural aggregate sources would be minimal. This method requires that the only “non-standard” test performed on the RCA be measurement of the residual mortar content by mass. This method allowed for the cement content to be reduced to 52% that of the corresponding control mix; unfortunately, the workability of the mix was not ideal with these replacement rates and this is believed to have compromised the strength of the cylinders tested. Despite the shortcomings of this design method in the fresh state, the strength that was achieved can accurately be used to estimate the elastic modulus of the concrete of the material using design equations. Modulus of rupture is less predictable when non-concrete aggregates are present.

With a reduced fresh mortar content, the quality of the RCA source has a significant role in the quality of the final product. Testing of the cylinders exposed the interior of the aggregates used, revealing a higher content of nonconcrete aggregates than initially estimated. The presence of undesirable material (asphalt, clay brick etc.) will reduce the strength and stiffness of the concrete. When using RCA for concrete, and especially concrete intended for structural applications where compressive strength and mechanical properties are of high importance, the aggregate must be appropriately screened and processed before use. It is unrealistic to expect adequate performance of RCA concrete containing poor quality aggregates and deleterious materials.

A modified Abrams Law is recommended for use with RCA concretes. Findings suggest that to achieve comparable strength to the control mix, RCA concretes with low cement content must utilize a lower w/c ratio. The new equation developed in the project was able to accurately predict the w/c ratio of 0.42 needed to reach 35 MPa with 100% RCA replacement for the aggregates used in this study. The applicability of this specific equation to other sources of RCA is unknown and a modified Abrams law may need to be calculated for each RCA source for the most accurate results, but knowing that a reduced w/c ratio is required compared to natural aggregate sources can begin the basis of future development.

Modification of mix proportions through a modified EMV method is one solution to improve the consistency and workability of RCA. Strategically increasing the volume of cement and decreasing the volume of fine aggregates can reduce the viscosity of the mortar enough that it is able to more uniformly cover the RCA particles. Combining the modifications to the w/c ratio and cement contents, a 35Mpa mix was optimized, with 322 kg/m<sup>3</sup> of cement, corresponding to a 19.5% decrease in the mass of cement and a bit lower than 10 (9.2 kg/m<sup>3</sup>•Mpa<sup>-1</sup>). The sustainability of RCA concrete could also be further improved with the inclusion of supplementary cementitious materials to further reduce the cement content.

The flexural capacity of under-reinforced members made with the reduced cement content RCA concrete was comparable to control members tested. The behaviour of the members prior to yielding of the reinforcement was predictable when designed in accordance with CSA A23.3-14. The post-yield behaviour of the members was less predictable, with only one test member having similar behaviour to the control. The capacity of the members does not appear to be correlated to the replacement percentage with RCA.

The shear capacity of the RCA beams, although comparable to the capacity of the control member, was less predictable than the flexural capacity. The control member had a failure as calculated using the general method of CSA A23.3-14, while the 50% RCA member failed in flexure by yielding of the steel reinforcement at a load 25% higher than the control beam, and the 100% RCA member failed at 85% of the calculated capacity. While reduction in shear strength cannot be directly correlated to the percentage of RCA replacement (more RCA does not always equal less strength), the RCA properties and aggregate packing structure clearly do have an impact on the aggregate interlock mechanism and shear strength of the concrete.

While cracks measured on the surfaces of the concrete beams did not vary significantly between the control members and the RCA members, visual inspections of the shear failure planes and polished cores showed that each of the concrete mixes had different paths for crack development. The increased tortuosity of the crack path in the 50% RCA sample helps explain the increased shear strength of the members, but in the case of the 100% RCA mix this resulted in greater energy required than for aggregate fracture, resulting in a smoother crack surface.

Measurement of the mechanical properties of reduced cement content RCA concrete (i.e. elastic modulus, compressive strength) are not the only properties at play when looking at the capacity of RCA members. Research of concrete often divides itself into two categories, material properties and structural performance. Although presented as two separate chapters,

these areas of research are highly dependent on each other. For design of concrete members in flexure, compressive strength is the only mechanical property of concrete used; it is easy to assume that concrete having the prescribed compressive strength will have suitable performance. Shear capacity, per CSA A23.3-14, adds in a factor to account for aggregate size as it relates to aggregate interlock, but no other mechanical properties are required for design. It was shown that the dissimilar micro-structure of reduced cement content RCA concrete leads to cracks forming differently than in natural aggregate concrete, making the development of cracks and the shear capacity of the RCA members more variable than the controls. Further research on the microstructure of both RCA and RCA concrete will be essential in understanding the differences in the materials and establishing predictable models for calculating the shear strength of structural members.

Based on the results obtained in this study, the following recommendations are made for future research topics:

- Microscopic studies to quantify some of the observations made about material and structural behaviour will help to bridge the gap between the mechanical properties and structural behaviour of RCA concrete. Measurements of tortuosity of each failure plane, density of aggregates (both NA and RCA) and particle spacing are just some of the parameters that can be compared on cores taken from concrete beams. Using RCA from varied sources, perhaps with properties that are well known, and developing concrete with a greater range of RCA replacement would help to determine under what circumstances RCA behaves similar to or differently from natural aggregates.
- Serviceability of RCA concrete should be studied for short and long-term performance. Short and long-term crack development and widths should be studied and compared to traditional concretes. For most applications concrete only sees service level loads, not failure loads, so how it behaves under these loads is important to understand. Wider

cracks are a concern from a durability standpoint if concrete is exposed to water or chemicals and can be perceived as a safety concern if visible to users of a structure. Long term there may be impacts on creep and fatigue behaviour if concrete contains mortars of different age and usage.

- As RCA research continues to show that RCA concrete need not be an inferior material if properly understood, more opportunities for using and studying RCA may emerge. Further optimization of mix designs through inclusion of SCMs and design procedures for reducing cement content, for example packing models, could be introduced to reduced cement RCA concrete, improving cement efficiency and sustainability of the material. The relationship between the residual mortar strength and possible strength limits of new RCA concrete could yield results that help improve guidelines and restrictions for applications and limitations of RCA's use.

## 6. References

- [1] Cement Sustainability Initiative, *Recycling Concrete*, Geneva, Switzerland, 2009.
- [2] B.L. Damineli, F.M. Kemeid, P.S. Aguiar, V.M. John, Measuring the eco-efficiency of cement use, *Cement and Concrete Composites*. 32 (2010) 555–562. doi:10.1016/j.cemconcomp.2010.07.009.
- [3] Cement Sustainability Initiative, *Guidelines for Emissions Monitoring and Reporting in the Cement Industry*, 2012.
- [4] N. Müller, J. Harnisch, *A blueprint for a climate friendly cement industry (A report prepared for the WWF – Lafarge Conservation Partnership)*, Gland, Switzerland, 2008.
- [5] T.C. Hansen, Recycled aggregates and recycled aggregate concrete second state-of-the-art report developments 1945-1985, *Materials and Structures*. 19 (1986) 201–246. doi:10.1007/BF02472036.
- [6] Altus Group Economic Consulting, *State of the Aggregate Resource in Ontario Study (SAROS) Paper 1 -Aggregate Consumption and Demand*, 2009.
- [7] A. Abbas, G. Fathifazl, B. Fournier, O.B. Isgor, R. Zavadil, A.G. Razaqpur, S. Foo, Quantification of the residual mortar content in recycled concrete aggregates by image analysis, *Materials Characterization*. 60 (2009) 716–728. doi:10.1016/j.matchar.2009.01.010.
- [8] C. Pellegrino, F. Faleschini, *Sustainability Improvements in the Concrete Industry*, 2016. doi:10.1007/978-3-319-28540-5.
- [9] S.B. Marinković, I. Ignjatović, V. Radonjanin, *Life-cycle assessment (LCA) of concrete with recycled aggregates (RAs)*, 2013. doi:10.1533/9780857096906.4.569.

- [10] I.S. Ignjatović, S.B. Marinković, Z.M. Mišković, A.R. Savić, Flexural behavior of reinforced recycled aggregate concrete beams under short-term loading, *Materials and Structures*. (2012) 1045–1059. doi:10.1617/s11527-012-9952-9.
- [11] S. Yang, H. Lee, Mechanical properties of recycled aggregate concrete proportioned with modified equivalent mortar volume method for paving applications, *Construction and Building Materials*. 136 (2017) 9–17. doi:10.1016/j.conbuildmat.2017.01.029.
- [12] M. Malešev, V. Radonjanin, G. Broćeta, Properties of recycled aggregate concrete, *Contemporary Materials*. 2 (2014) 239–249. doi:10.7251/COMEN1402239M.
- [13] R. Dhir, K. Paine, N. Ho, C.S. Poon, M. Etxeberria, J. De Brito, V. Tam, Use of Recycled and Secondary Aggregates in Concrete: An Overview, in: 2011. doi:10.13140/rg.2.1.4378.2166.
- [14] Canadian Standards Association, CSA A23.1-14/A23.2-14, Concrete materials and methods of concrete construction - test methods and standard practices for concrete, CSA, Missisagua, Ontario, Canada, 2014.
- [15] P. Grubl, M. Ruhl, German Committee for Reinforced Concrete (DAfStb) - Code: Concrete with Recycled Aggregates, in: International Symposium on Sustainable Construction: Use of Recycled Coarse Aggregate, University of Dundee, Concrete Technology Unit, London (UK), 1998.
- [16] I. Maruyama, M. Sogo, T. Sogabe, R. Sato, K. Kawai, Flexural properties of reinforced recycled concrete beams, International RILEM Conference on the Use of Recycled Materials in Buildings and Structures, 8-11 November. (2004) 525–535.
- [17] J.F. Lamond, R.L. Campbell, T.R. Campbell, J.A. Cazares, A. Giraldo, W. Halczak, H.C. Hale, N.J.T. Jenkins, R. Miller, P.T. Seabrook, ACI 555R-01 - Removal and reuse of

hardened concrete, 2002.

- [18] EN (European Standard), EN 206 2013. Concrete — Specification, performance, production and conformity, 2013.
- [19] Standards New Zealand, NZS 3101:Part 1:2006 Concrete Structures Standard, Standards New Zealand, Wellington N.Z, 2006.
- [20] M. Kisan, S. Sangathan, J. Nehru, S.G. Pitroda, IS 10262:2009 - Guidelines for Concrete Mix Design Proportioning, Bureau of Indian Standards, New Dehli, 2009.
- [21] G. Fathifazl, A.G. Razaqpur, O.B. Isgor, A. Abbas, B. Fournier, S. Foo, Proportioning Concrete Mixtures with Recycled Concrete Aggregate, Concrete International. (2010) 37–43.
- [22] G. Fathifazl, A.G. Razaqpur, O. Burkan Isgor, A. Abbas, B. Fournier, S. Foo, Shear capacity evaluation of steel reinforced recycled concrete (RRC) beams, Engineering Structures. 33 (2011) 1025–1033. doi:10.1016/j.engstruct.2010.12.025.
- [23] G. Fathifazl, A. Abbas, A.G. Razaqpur, O.B. Isgor, B. Fournier, S. Foo, Shear strength of reinforced recycled concrete beams without stirrups, Magazine of Concrete Research. 61 (2009) 477–490. doi:10.1680/mac.2008.61.7.477.
- [24] G. Fathifazl, A.G. Razaqpur, O.B. Isgor, A. Abbas, B. Fournier, S. Foo, Shear strength of reinforced concrete beams with stirrups, Magazine of Concrete Research. 62 (2010) 685–699. doi:10.1617/s11527-007-9223-3.
- [25] G. Fathifazl, A.G. Razaqpur, O.B. Isgor, A. Abbas, B. Fournier, S. Foo, Flexural Performance of Steel-Reinforced Recycled Concrete Beams, ACI Structural Journal. 106 (2009) 858–867.
- [26] G. Fathifazl, A. Ghani Razaqpur, O. Burkan Isgor, A. Abbas, B. Fournier, S. Foo, Creep

- and drying shrinkage characteristics of concrete produced with coarse recycled concrete aggregate, *Cement and Concrete Composites*. 33 (2011) 1026–1037. doi:10.1016/j.cemconcomp.2011.08.004.
- [27] G. Fathifazl, A.G. Razaqpur, Creep Rheological Models for Recycled Aggregate Concrete, *ACI Materials Journal*. 110 (2014) 115–126.
- [28] A. Abbas, G. Fathifazl, O.B. Isgor, A.G. Razaqpur, B. Fournier, S. Foo, Durability of recycled aggregate concrete designed with equivalent mortar volume method, *Cement and Concrete Composites*. 31 (2009) 555–563. doi:10.1016/j.cemconcomp.2009.02.012.
- [29] L. Carvalho, Durability properties of low cement concrete (LCC), (2017).
- [30] F. Debieb, L. Courard, S. Kenai, R. Degeimbre, Mechanical and durability properties of concrete using contaminated recycled aggregates, *Cement and Concrete Composites*. 32 (2010) 421–426. doi:10.1016/j.cemconcomp.2010.03.004.
- [31] R. Wassermann, A. Katz, A. Bentur, Minimum cement content requirements: a must or a myth?, *Materials and Structures*. 42 (2009) 973–982. doi:10.1617/s11527-008-9436-0.
- [32] R.K. Dhir, M.J. McCarthy, S. Zhou, P.A.J. Tittle, Role of cement content in specifications for concrete durability: cement type influences, *Proceedings of the Institution of Civil Engineers - Structures and Buildings*. 157 (2004) 113–127. doi:10.1680/stbu.2004.157.2.113.
- [33] K. Rahal, Mechanical properties of concrete with recycled coarse aggregate, *Building and Environment*. 42 (2007) 407–415. doi:10.1016/j.buildenv.2005.07.033.
- [34] A. Sucic, A. Lotfy, Effect of new paste volume on performance of structural concrete

- using coarse and granular recycled concrete aggregate of controlled quality, *Construction and Building Materials*. 108 (2016) 119–128. doi:10.1016/j.conbuildmat.2015.10.064.
- [35] G. Fathifazl, A. Abbas, A.G. Razaqpur, O.B. Isgor, B. Fournier, S. Foo, New Mixture Proportioning Method for Concrete Made with Coarse Recycled Concrete Aggregate, *Journal of Materials in Civil Engineering*. 21 (2009) 601–611. doi:10.1061/(ASCE)0899-1561(2009)21:10(601).
- [36] M. Etxeberria, A.R. Marí, E. Vázquez, Recycled aggregate concrete as structural material, *Materials and Structures*. 40 (2007) 529–541. doi:10.1617/s11527-006-9161-5.
- [37] V.M. Malhotra, Recycled concrete—a new aggregate, *Canadian Journal of Civil Engineering*. 5 (1978) 42–52. doi:10.1139/l78-006.
- [38] S. Arora, S.P. Singh, Analysis of flexural fatigue failure of concrete made with 100% Coarse Recycled Concrete Aggregates, *Construction and Building Materials*. 102 (2016) 782–791. doi:10.1016/j.conbuildmat.2015.10.098.
- [39] N. Fonseca, J. De Brito, L. Evangelista, The influence of curing conditions on the mechanical performance of concrete made with recycled concrete waste, *Cement and Concrete Composites*. 33 (2011) 637–643. doi:10.1016/j.cemconcomp.2011.04.002.
- [40] S. Omary, E. Ghorbel, G. Wardeh, Relationships between recycled concrete aggregates characteristics and recycled aggregates concretes properties, *Construction and Building Materials*. 108 (2016) 163–174. doi:10.1016/j.conbuildmat.2016.01.042.
- [41] M. Malešev, V. Radonjanin, S. Marinković, Recycled concrete as aggregate for structural concrete production, *Sustainability*. 2 (2010) 1204–1225.

doi:10.3390/su2051204.

- [42] I. Nováková, K. Mikulica, Properties of Concrete with Partial Replacement of Natural Aggregate by Recycled Concrete Aggregates from Precast Production, *Procedia Engineering*. 151 (2016) 360–367. doi:10.1016/j.proeng.2016.07.387.
- [43] P.J. Nixon, Recycled concrete as an aggregate for concrete - a review. First state-of-the-art report RILEM TC-37-DRC., *Matériaux et Construction*. 11 (1978) 371–378. doi:10.1007/BF02473878.
- [44] G. Wardeh, E. Ghorbel, H. Gomart, Mix Design and Properties of Recycled Aggregate Concretes: Applicability of Eurocode 2, *International Journal of Concrete Structures and Materials*. 9 (2015) 1–20. doi:10.1007/s40069-014-0087-y.
- [45] ASTM International, ASTM Standard C33/C33-Me1, Standard Specification for Concrete Aggregates, West Conshohocken, PA, 2016. doi:10.1520/C0033\_C0033M-16E01.
- [46] American Association of State Highway and Transportation Officials, AASHTO M 80:2013 - Specification For Coarse Aggregate For Hydraulic Cement Concrete, Washington, D.C., 2013.
- [47] N. Kisku, H. Joshi, M. Ansari, S.K. Panda, S. Nayak, S.C. Dutta, A critical review and assessment for usage of recycled aggregate as sustainable construction material, *Construction and Building Materials*. 131 (2016) 721–740. doi:10.1016/j.conbuildmat.2016.11.029.
- [48] I. González-Taboada, B. González-Fonteboa, F. Martínez-Abella, D. Carro-López, Study of recycled concrete aggregate quality and its relationship with recycled concrete compressive strength using database analysis, *Materiales de Construcción*. 66 (2016).

doi:10.3989/mc.2016.06415.

- [49] M. Sánchez, D. Juan, P. Alaejos, Study on the influence of attached mortar content on the properties of recycled concrete aggregate, *Construction and Building Materials*. 23 (2009) 872–877. doi:10.1016/j.conbuildmat.2008.04.012.
- [50] T.C. Hansen, H. Narud, Strength of recycled concrete made from crushed concrete coarse aggregate, *Concrete International*. 5 (1983) 79–83.
- [51] L. Butler, J.S. West, S.L. Tighe, Quantification of Recycled Concrete Aggregate (RCA) Properties for Usage in Bridges and Pavements: An Ontario Case Study, in: *Innovative Developments in Sustainable Pavements Session*, Conference of the Transportation Association of Canada, 2011.
- [52] Gómez-Soberón, J.M. V, Porosity of recycled concrete with substitution of recycled concrete aggregate: An experimental study, *Cement and Concrete Research*. 32 (2002) 1301–1311. doi:10.1016/S0008-8846(02)00795-0.
- [53] M. Martín-Morales, M. Zamorano, I. Valverde-Palacios, G.M. Cuenca-Moyano, Z. Sánchez-Roldán, *Quality control of recycled aggregates (RAs) from construction and demolition waste (CDW)*, Woodhead Publishing Limited, 2013. doi:10.1533/9780857096906.2.270.
- [54] A. Katz, Properties of concrete made with recycled aggregate from partially hydrated old concrete, *Cement and Concrete Research*. 33 (2003) 703–711. doi:10.1016/S0008-8846(02)01033-5.
- [55] N. Kim, J. Kim, S. Yang, Mechanical strength properties of RCA concrete made by a modified EMV method, *Sustainability*. 8 (2016) 1–15. doi:10.3390/su8090924.
- [56] V.W.Y. Tam, C.M. Tam, K.N. Le, Removal of cement mortar remains from recycled

- aggregate using pre-soaking approaches, *Resources, Conservation and Recycling*. 50 (2007) 82–101. doi:10.1016/j.resconrec.2006.05.012.
- [57] Q. Liu, J. Xiao, Z. Sun, Experimental study on the failure mechanism of recycled concrete, *Cement and Concrete Research*. 41 (2011) 1050–1057. doi:10.1016/j.cemconres.2011.06.007.
- [58] M.R. Khan, Post heat exposure behaviour of reinforced concrete beams, *Magazine of Concrete Research*: 38 (1986) 59–66.
- [59] Q. Ma, R. Guo, Z. Zhao, Z. Lin, K. He, Mechanical properties of concrete at high temperature — A review, *Construction and Building Materials*. 93 (2015) 371–383. doi:10.1016/j.conbuildmat.2015.05.131.
- [60] U. Schneider, Concrete at High Temperatures - - A General Review, *Fire Safety Journal*. 13 (1988) 55–68.
- [61] V.W.Y. Tam, Improving waste management plans in construction projects, Woodhead Publishing Limited, 2013. doi:10.1533/9780857096906.1.9.
- [62] X.X. Gao, M. Cyr, S. Multon, A. Sellier, A three-step method for the recovery of aggregates from concrete, *Construction and Building Materials*. 45 (2013) 262–269. doi:10.1016/j.conbuildmat.2013.04.003.
- [63] I.B. Topcu, S. Sengel, Properties of concretes produced with waste ceramic tile aggregate, *Asian Journal of Civil Engineering*. 14 (2013) 369–382. doi:10.1016/j.cemconres.2003.12.019.
- [64] S.C. Kou, C.S. Poon, Long-term mechanical and durability properties of recycled aggregate concrete prepared with the incorporation of fly ash, *Cement and Concrete Composites*. 37 (2013) 12–19. doi:10.1016/j.cemconcomp.2012.12.011.

- [65] A. Abd Elhakam, A.E. Mohamed, E. Awad, Influence of self-healing, mixing method and adding silica fume on mechanical properties of recycled aggregates concrete, *Construction and Building Materials*. 35 (2012) 421–427. doi:10.1016/j.conbuildmat.2012.04.013.
- [66] C.S. Poon, Z.H. Shui, L. Lam, Effect of microstructure of ITZ on compressive strength of concrete prepared with recycled aggregates, *Construction and Building Materials*. 18 (2004) 461–468. doi:10.1016/j.conbuildmat.2004.03.005.
- [67] A.M. Alkhaleefi, N.Z. Almutairi, Strength of Concrete Made With Crushed Concrete Strength of Concrete Made With Crushed Concrete, in: *Our World in Concrete & Structures*, Singapore, 2006.
- [68] O.A. Mohamed, Z.I. Syed, O.F. Najm, Splitting Tensile Strength of Sustainable self-consolidating Concrete, in: *International Conference on Sustainable Design, Engineering and Construction*, Elsevier B.V., 2016: pp. 1218–1225. doi:10.1016/j.proeng.2016.04.157.
- [69] Canadian Standards Association, CSA A23.3-14 - Design of Concrete Structures, CSA, Missisagua, Ontario, Canada, 2014.
- [70] S.A. Mirza, J.G. MacGregor, M. Hatzinikolas, Statistical descriptions of strength of concrete, *Journal of the Structural Division*. 105 (1979) 1021–1037.
- [71] R. V. Silva, J. De Brito, R.K. Dhir, Tensile strength behaviour of recycled aggregate concrete, *Construction and Building Materials*. 83 (2015) 108–118. doi:10.1016/j.conbuildmat.2015.03.034.
- [72] S. Ahmad, S.A. Alghamdi, A Study on Effect of Coarse Aggregate Type on Concrete Performance, *Arabian Journal for Science and Engineering*. 37 (2012) 1777–1786.

doi:10.1007/s13369-012-0282-6.

- [73] ACI, Building Code Requirements for Structural Concrete (ACI 318-14) and Commentary (ACI 318R-14), 2014. doi:10.1016/0262-5075(85)90032-6.
- [74] İ.B. Topçu, N.F. Günçan, Using waste concrete as aggregate, *Cement and Concrete Research*. 25 (1995) 6.
- [75] J. Xiao, J. Li, C. Zhang, Mechanical properties of recycled aggregate concrete under uniaxial loading, *Cement and Concrete Research*. 35 (2005) 1187–1194. doi:10.1016/j.cemconres.2004.09.020.
- [76] M. Guedes, L. Evangelista, J. De Brito, A.C. Ferro, Microstructural Characterization of Concrete Prepared with Recycled Aggregates, *Microscopy and Microanalysis*. 19 (2013) 1222–1230. doi:10.1017/S1431927613001463.
- [77] S. Nagataki, A. Gokce, T. Saeki, M. Hisada, Assessment of recycling process induced damage sensitivity of recycled concrete aggregates, *Cement and Concrete Research*. 34 (2004) 965–971. doi:10.1016/j.cemconres.2003.11.008.
- [78] G.C. Lee, H.B. Choi, Study on interfacial transition zone properties of recycled aggregate by micro-hardness test, *Construction and Building Materials*. 40 (2013) 455–460. doi:10.1016/j.conbuildmat.2012.09.114.
- [79] K.L. Scrivener, D.B. Teknik, The Interfacial Transition Zone ( ITZ ) Between Cement Paste and Aggregate, (2004) 411–421.
- [80] J. Xiao, W. Li, Z. Sun, D.A. Lange, S.P. Shah, Properties of interfacial transition zones in recycled aggregate concrete tested by nanoindentation, *Cement and Concrete Composites*. 37 (2013) 276–292. doi:10.1016/j.cemconcomp.2013.01.006.
- [81] D. Matias, J. De Brito, A. Rosa, D. Pedro, Durability of Concrete with Recycled Coarse

- Aggregates : Influence of Superplasticizers, *Journal of Materials in Civil Engineering*. 6014011 (2014) 1–5. doi:10.1061/(ASCE)MT.1943-5533.0000961.
- [82] A. Domingo-cabo, C. Lázaro, F. López-gayarre, M.A. Serrano-lópez, P. Serna, J.O. Castaño-tabares, Creep and shrinkage of recycled aggregate concrete, *Construction and Building Materials*. 23 (2009) 2545–2553. doi:10.1016/j.conbuildmat.2009.02.018.
- [83] W.H. Kwan, M. Ramli, K.J. Kam, M.Z. Sulieman, Influence of the amount of recycled coarse aggregate in concrete design and durability properties, *Construction and Building Materials*. 26 (2012) 565–573. doi:10.1016/j.conbuildmat.2011.06.059.
- [84] F. Buyle-Bodin, R. Hadjieva-Zaharieva, Influence of industrially produced recycled aggregates on flow properties of concrete, *Materials and Structures/Materiaux et Constructions*. 35 (2002) 504–509. doi:10.1007/BF02483138.
- [85] S.C. Kou, C.S. Poon, Enhancing the durability properties of concrete prepared with coarse recycled aggregate, *Construction and Building Materials*. 35 (2012) 69–76. doi:10.1016/j.conbuildmat.2012.02.032.
- [86] R. Somna, C. Jaturapitakkul, A.M. Amde, Effect of ground fly ash and ground bagasse ash on the durability of recycled aggregate concrete, *Cement and Concrete Composites*. 34 (2012) 848–854. doi:10.1016/j.cemconcomp.2012.03.003.
- [87] Y.A. Villagrán-Zaccardi, C.J. Zega, Á.A. Di Maio, Chloride Penetration and Binding in Recycled Concrete, *Journal of Materials in Civil Engineering*. 20 (2008) 449–455. doi:10.1061/(ASCE)0899-1561(2008)20:6(449).
- [88] S.C. Kou, C.S. Poon, D. Chan, Influence of fly ash as a cement addition on the hardened properties of recycled aggregate concrete, *Materials and Structures*. 41 (2008) 1191–1201. doi:10.1617/s11527-007-9317-y.

- [89] E. Vázquez, M. Barra, D. Aponte, C. Jiménez, S. Valls, Improvement of the durability of concrete with recycled aggregates in chloride exposed environment, *Construction and Building Materials*. 67 (2014) 61–67. doi:10.1016/j.conbuildmat.2013.11.028.
- [90] N. Jain, M. Garg, A.K. Minocha, Green Concrete from Sustainable Recycled Coarse Aggregates : Mechanical and Durability Properties, *Journal of Waste Management*. 2015 (2015) 8. doi:10.1155/2015/281043.
- [91] M. Tuyan, A. Mardani-Aghabaglou, K. Ramyar, Freeze-thaw resistance, mechanical and transport properties of self-consolidating concrete incorporating coarse recycled concrete aggregate, *Materials and Design*. 53 (2014) 983–991. doi:10.1016/j.matdes.2013.07.100.
- [92] M. Chakradhara Rao, S.K. Bhattacharyya, S. V. Barai, Influence of field recycled coarse aggregate on properties of concrete, *Materials and Structures*. 44 (2011) 205–220. doi:10.1617/s11527-010-9620-x.
- [93] J.A. Bogas, J. de Brito, D. Ramos, Freeze-thaw resistance of concrete produced with fine recycled concrete aggregates, *Journal of Cleaner Production*. 115 (2015) 294–306. doi:10.1016/j.jclepro.2015.12.065.
- [94] A. Gokce, S. Nagataki, T. Saeki, M. Hisada, Freezing and thawing resistance of air-entrained concrete incorporating recycled coarse aggregate: The role of air content in demolished concrete, *Cement and Concrete Research*. 34 (2004) 799–806. doi:10.1016/j.cemconres.2003.09.014.
- [95] A.B. Ajdukiewicz, A.T. Kliszczewicz, Comparative Tests of Beams and Columns Made of Recycled Aggregate Concrete and Natural Aggregate Concrete, *Journal of Advanced Concrete Technology*. 5 (2007) 259–273. doi:10.3151/jact.5.259.

- [96] N. Tošić, S. Marinković, I. Ignjatović, A database on flexural and shear strength of reinforced recycled aggregate concrete beams and comparison to Eurocode 2 predictions, *Construction and Building Materials*. 127 (2016) 932–944. doi:10.1016/j.conbuildmat.2016.10.058.
- [97] Y. Lan, *Study on the Flexural and Shear Behaviour of RAC Beams*, Tongji University, Shanghai, 2005.
- [98] W.-C. Choi, H.-D. Yun, Shear Strength of Reinforced Recycled Concrete Beams Without Shear Reinforcements, *Journal of Civil Engineering and Management*. 23 (2017) 76–84.
- [99] B. González-Fontebao, F. Martínez-Abella, Shear strength of recycled concrete beams, *Construction and Building Materials*. 21 (2007) 887–893. doi:10.1016/j.conbuildmat.2005.12.018.
- [100] H. Katkhuda, N. Shatarat, Shear behavior of reinforced concrete beams using treated recycled concrete aggregate, *Construction and Building Materials*. 125 (2016) 63–71. doi:10.1016/j.conbuildmat.2016.08.034.
- [101] S. Sadati, M. Arezoumandi, K.H. Khayat, J.S. Volz, Shear performance of reinforced concrete beams incorporating recycled concrete aggregate and high-volume fly ash, *Journal of Cleaner Production*. 115 (2016) 284–293. doi:10.1016/j.jclepro.2015.12.017.
- [102] ACI, 211.1-91 Standard Practice for Selecting Proportions for Normal, Heavyweight, and Mass Concrete (Reapproved 2009), ACI, 1991.
- [103] ACI Committee 555, 555R-01: Removal and Reuse of Hardened Concrete, Technical Documents. (2002).
- [104] RILEM TC121-DRG, Specifications for Concrete with Recycled Aggregates, Materials

- and Structures. 27 (1994) 557–559.
- [105] Deutsches Institut für Normung, DIN 4226-100: Aggregates for Concrete and Mortar, Part 100-recycled aggregates., Deutsches Institut für Normung, Berlin, 2002.
- [106] J. de Brito, N. Saikia, Recycled Aggregate in Concrete, Springer-Verlag, London (UK), 2013. doi:10.1007/978-1-4471-4540-0.
- [107] Cement & Concrete Association of New Zealand, TR 14 - Best Practise Guide for the use of Recycled Aggregates in New Concrete, 2013.
- [108] ASTM International, ASTM C127-15 Standard Test Method for Relative Density (Specific Gravity) and Absorption of Coarse Aggregate, West Conshohocken, PA, 2015. doi:10.1520/C0127-15.
- [109] M. Pepe, R.D. Toledo Filho, E.A.B. Koenders, E. Martinelli, A novel mix design methodology for Recycled Aggregate Concrete, Construction and Building Materials. 122 (2016) 362–372. doi:10.1016/j.conbuildmat.2016.06.061.
- [110] G. Fathifazl, a. G. Razaqpur, O.B. Isgor, A. Abbas, B. Fournier, S. Foo, Bond performance of deformed steel bars in concrete produced with coarse recycled concrete aggregate, Canadian Journal of Civil Engineering. 39 (2012) 128–139. doi:10.1139/111-120.
- [111] L.J. Butler, J.S. West, S.L. Tighe, Bond of Reinforcement in Concrete Incorporating Recycled Concrete Aggregates, Journal of Structural Engineering. 141 (2014) 1–12. doi:10.1061/(ASCE)ST.1943-541X.0000928.

## **Appendix A: A Modified EMV Design Method Example**

**Table A-1: Material Properties of RCA and NA**

	RCA	NA
$W_{RCA}$ (kg)	3.00	-
$W_{OVA}$ (kg)	2.24	-
RMC (%)	25.3%	-
Bulk SG		
RCA	2.39	-
Bulk SG		
OVA	2.68	2.68
$V_{DR-NA}^{NAC}$	-	0.64
$RMC_{max}$	28.2%	-
* $R_{min}$	-4.1%	-

\*Obtained using EMV method design calculations per [7]

**Table A-2: Control Mix Design and Material Volumes**

Control NAC Mix	Mass (kg/m <sup>3</sup> )	Volume (L/m <sup>3</sup> )
Cement (kg/m <sup>3</sup> )	400	129
Fine Aggregate (kg/m <sup>3</sup> )	723	26
Coarse Aggregate (kg/m <sup>3</sup> )	1056	394
Water (L/m <sup>3</sup> )	180	180
Air (L/m <sup>3</sup> )	-	30
w/c ratio	0.45	-

2. Select Replacement Ratio:  $R (V_{NA}^{RCA-conc} / V_{RCA}^{NAC}) = 0.00$

3. Determine required volume of RCA

$$V_{RCA}^{RAC} = \frac{V_{NA}^{NAC} \times (1 - R)}{(1 - RMC) \times \frac{SG_{b,RCA}}{SG_{b,OVA}}} = \frac{394 L \times (1 - 0)}{(1 - 25.3\%) \times \frac{2.39}{2.68}} = 529L$$

$$W_{RCA}^{RAC} = V_{RCA}^{RAC} \times 2.68 kg/L = 529L \times 2.68 kg/L = 1416 kg$$

4. Determine required volume of NA:

$$V_{NA}^{RAC} = V_{NA}^{NAC} \times R = 394L \times 0 = 0$$

5. Convert volumes back to weights:

$$W_{OD-RCA}^{RAC} = V_{RCA}^{RAC} \cdot SG_{b,RCA} = 529 \times 2.68 = 1415 kg$$

$$W_{OD-NA}^{RAC} = V_{NA}^{RAC} \cdot SG_{b,NA} = 0 \times 2.7 = 0 kg$$

6. Subtract the volume of aggregates from the control to find the volume of mortar

$$V_{TM}^{NAC} = 1000L - V_{NA}^{NAC} = 1000L - 394L = 606L$$

7. Subtract the volume of residual mortar from the total mortar content of the control

$$V_{NM}^{RAC} = V_{TM}^{NAC} - V_{RCA}^{RAC} \left[ 1 - (1 - RMC) \times \frac{SG_{b,RCA}}{SG_{b,OVA}} \right]$$

$$= 606L - 529L \left[ 1 - (1 - 25.3\%) \left( \frac{2.39}{2.68} \right) \right] = 408L$$

8. Select the volumetric ratio of cement and fine aggregates  $\psi$ :

$$\psi = 6$$

(a value between the ratio in natural aggregate concretes and repair mortars as discussed in Section 3.)

9. Proportion the cement content using the new parameter:

$$V_c^{RAC} = V_c^{NAC} - V_{RM}^{RCA} \left( \frac{\frac{1}{SG_c}}{\frac{1}{SG_c} + \frac{1 * \psi}{SG_{FA}}} \right) = 129L - 198L * \frac{\frac{1}{3.1}}{\frac{1}{3.1} + \frac{6}{2.37}} = 104L$$

$$W_c^{RAC} = 104L * 3.1kg/L = 322 kg$$

10. Determine the volume of water required to hydrate the cement

$$W_w^{RAC} = W_c^{RAC} * (w/c) = 322 kg * 0.45 = 145kg$$

$$V_w^{RAC} = 145 L$$

11. The volume in the mix not comprised of RCA, natural aggregates, cement, water and air is the remaining volume required to be filled by fine aggregates:

$$V_{FA}^{RAC} = 1000L - V_w^{RAC} - V_{RCA}^{RAC} - V_{NA}^{RAC} - V_c^{RAC} - V_{air}^{RAC}$$

$$= 1000L - 145L - 529L - 0L - 104L - 30L = 193L$$

$$W_{FA}^{RAC} = 192L * 2.7kg/L = 521kg$$

**Table A-3: Comparison of Mix Designs (kg/m<sup>3</sup>)**

	Control NAC Mix	M-EMV Mix with 100% RCA
<b>Cement (kg/m<sup>3</sup>)</b>	400	322
<b>Fine Aggregate (kg/m<sup>3</sup>)</b>	723	521
<b>Coarse Aggregate (kg/m<sup>3</sup>)</b>	1056	0
<b>RCA (kg/m<sup>3</sup>)</b>	0	1416
<b>Water (L/m<sup>3</sup>)</b>	180	145

## **Appendix B : Stress-Strain Curves for Concrete Cylinders**

Data Provided for a Select Trial Batches and from Mixes used for Beam Testing

Beam - Cylinder Stress-Strain Curves

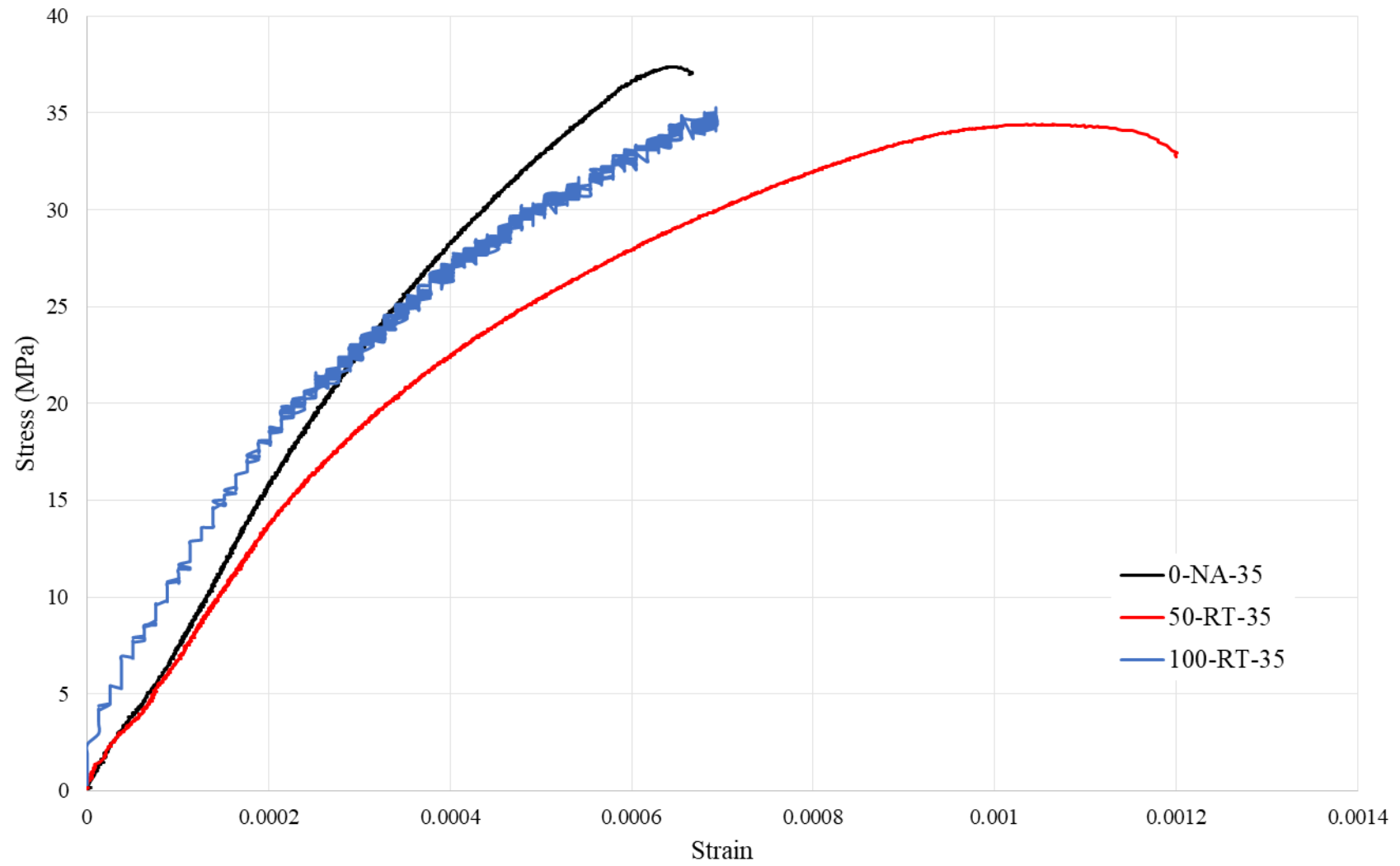

25 MPa Cylinder Stress-Strain Curves

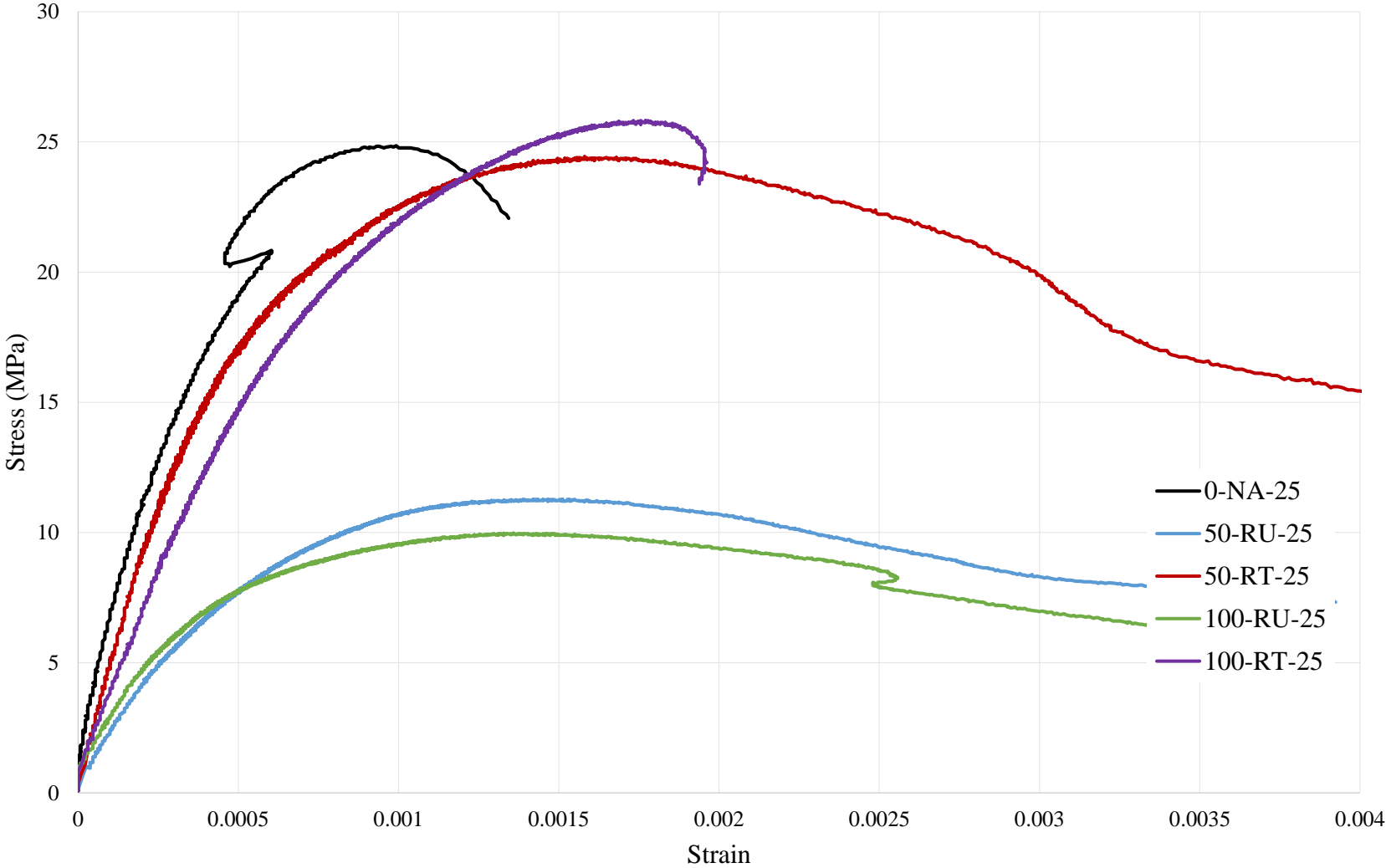

35 MPa Cylinder Stress-Strain Curves

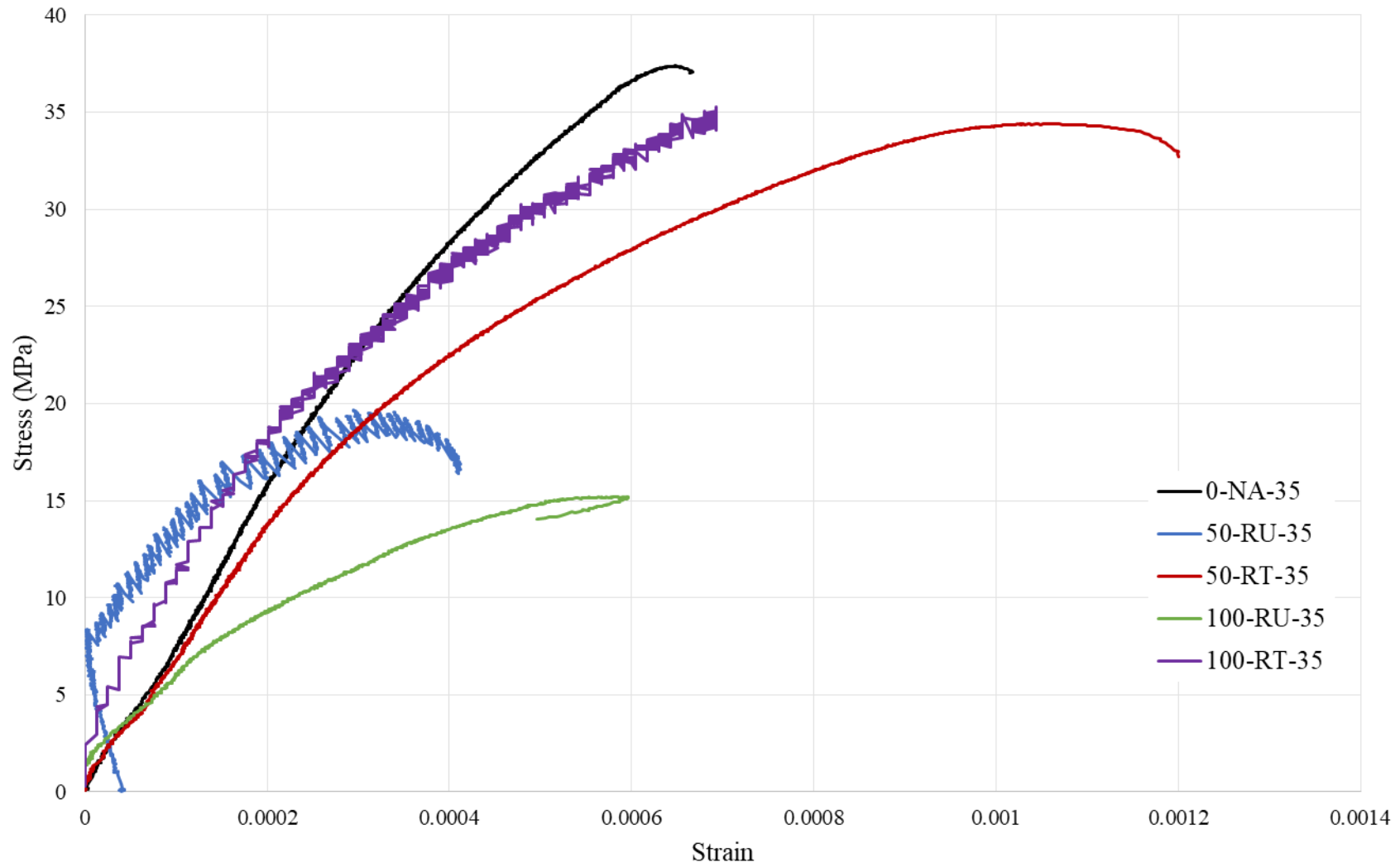

## **Appendix C: Beam Test Strain Gauge Data**

\*Strain Gauge Data for Beam 50-FL did not record correctly during testing and has been omitted from this appendix. Strain gauge data has been omitted where gauges were damaged or defective.

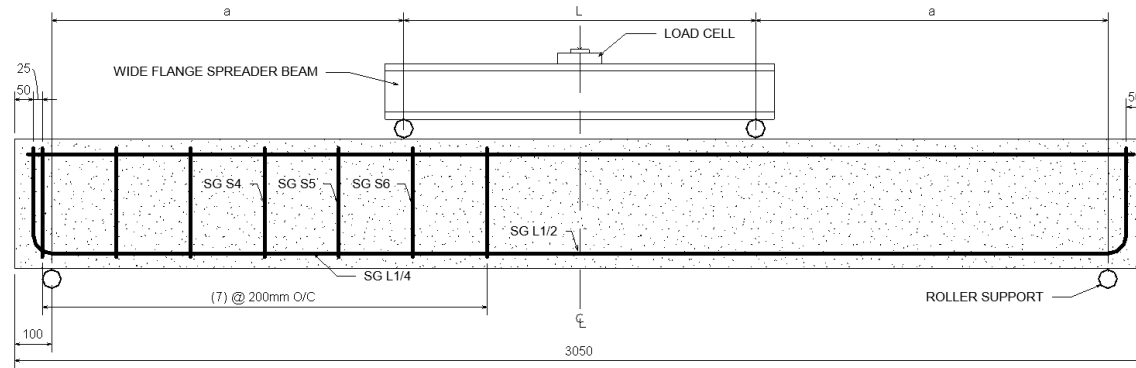

**Figure A-1: Shear Failure Beam Design**

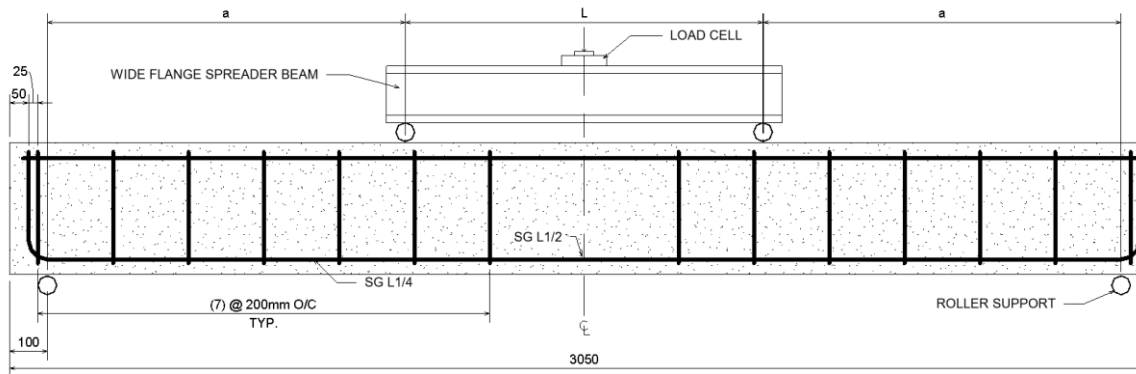

**Figure A-2: Flexural Failure Beam Design**

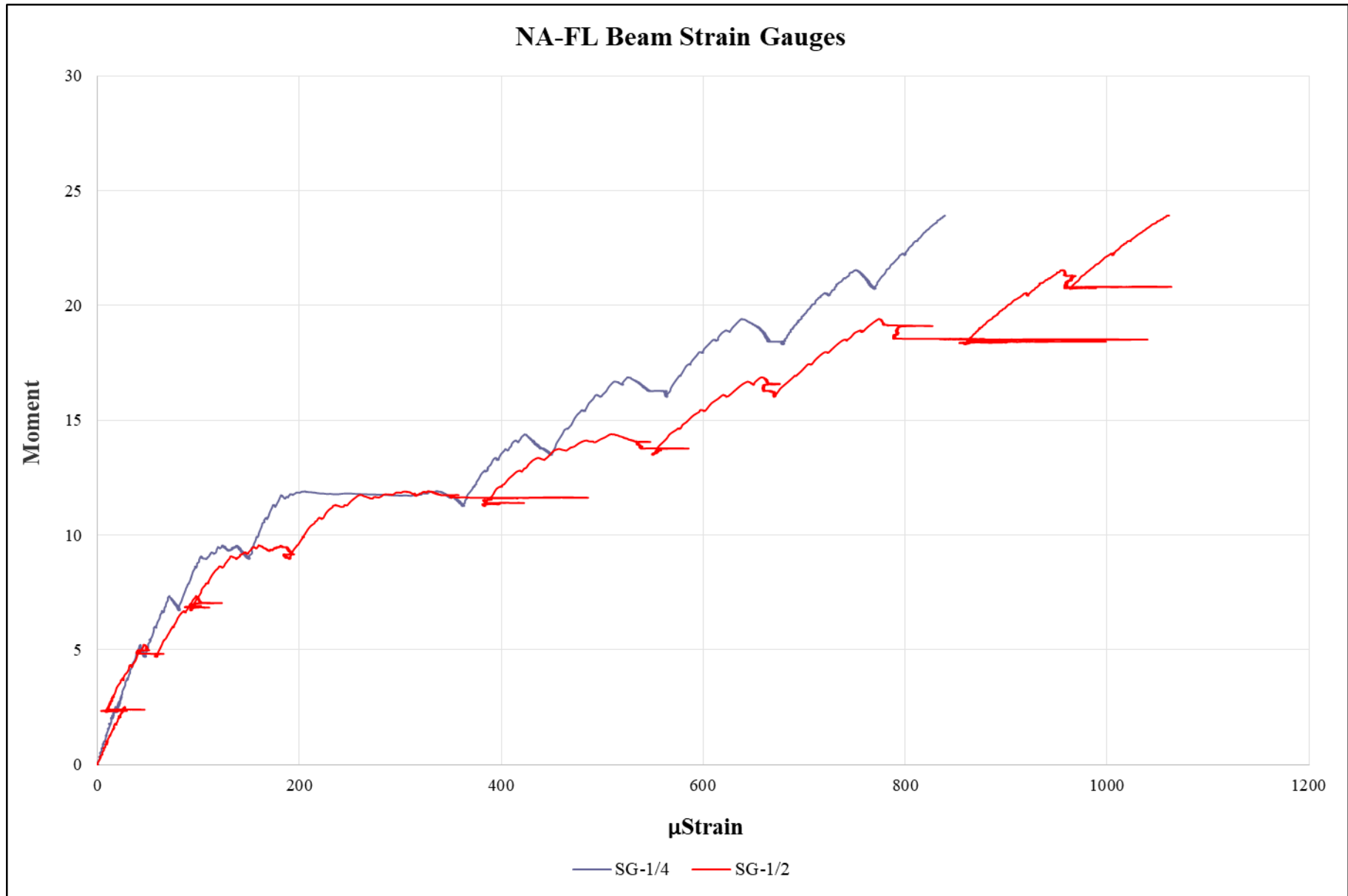

### NA-S Beam Strain Gauges

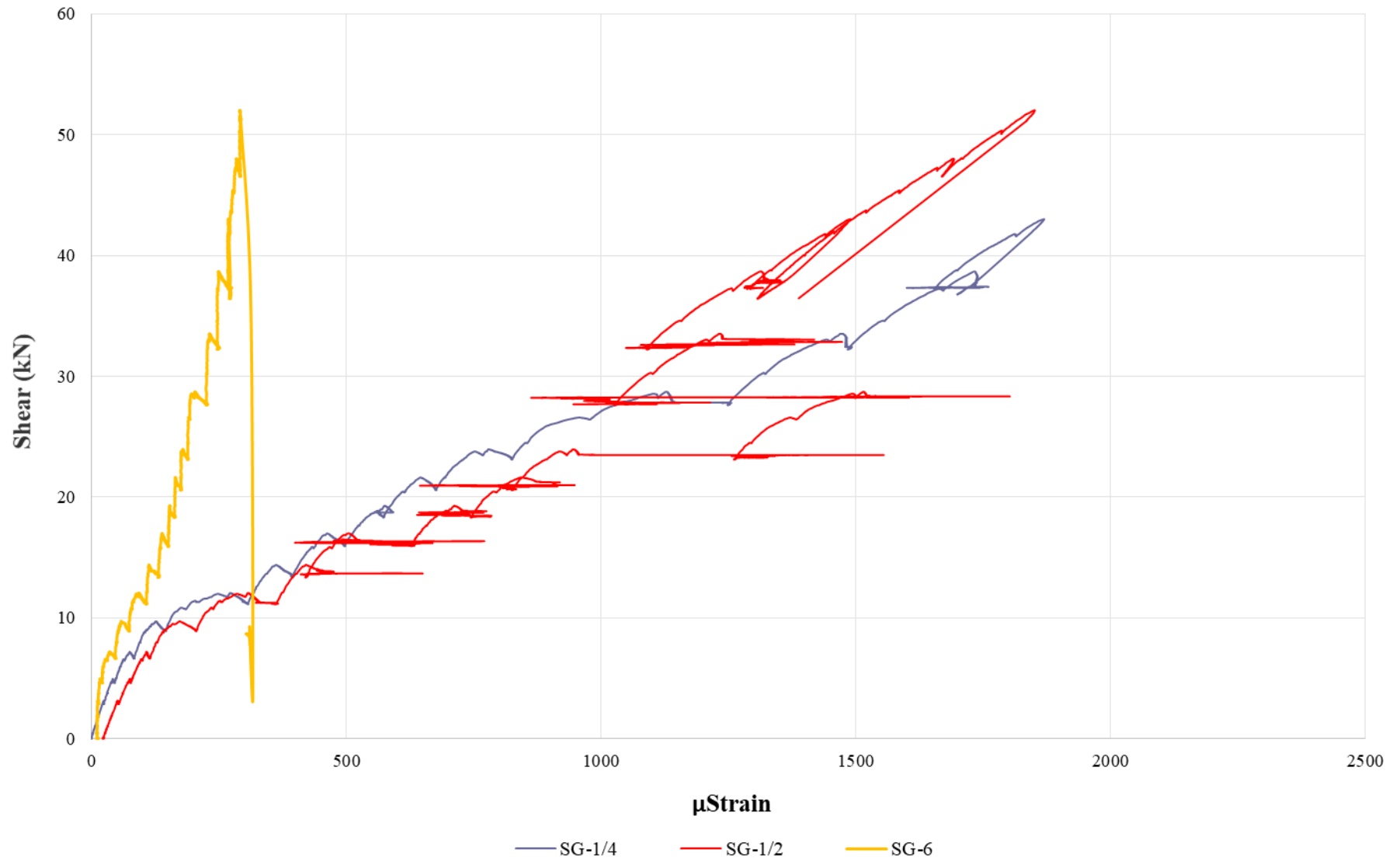

50-S Beam Strain Gauges

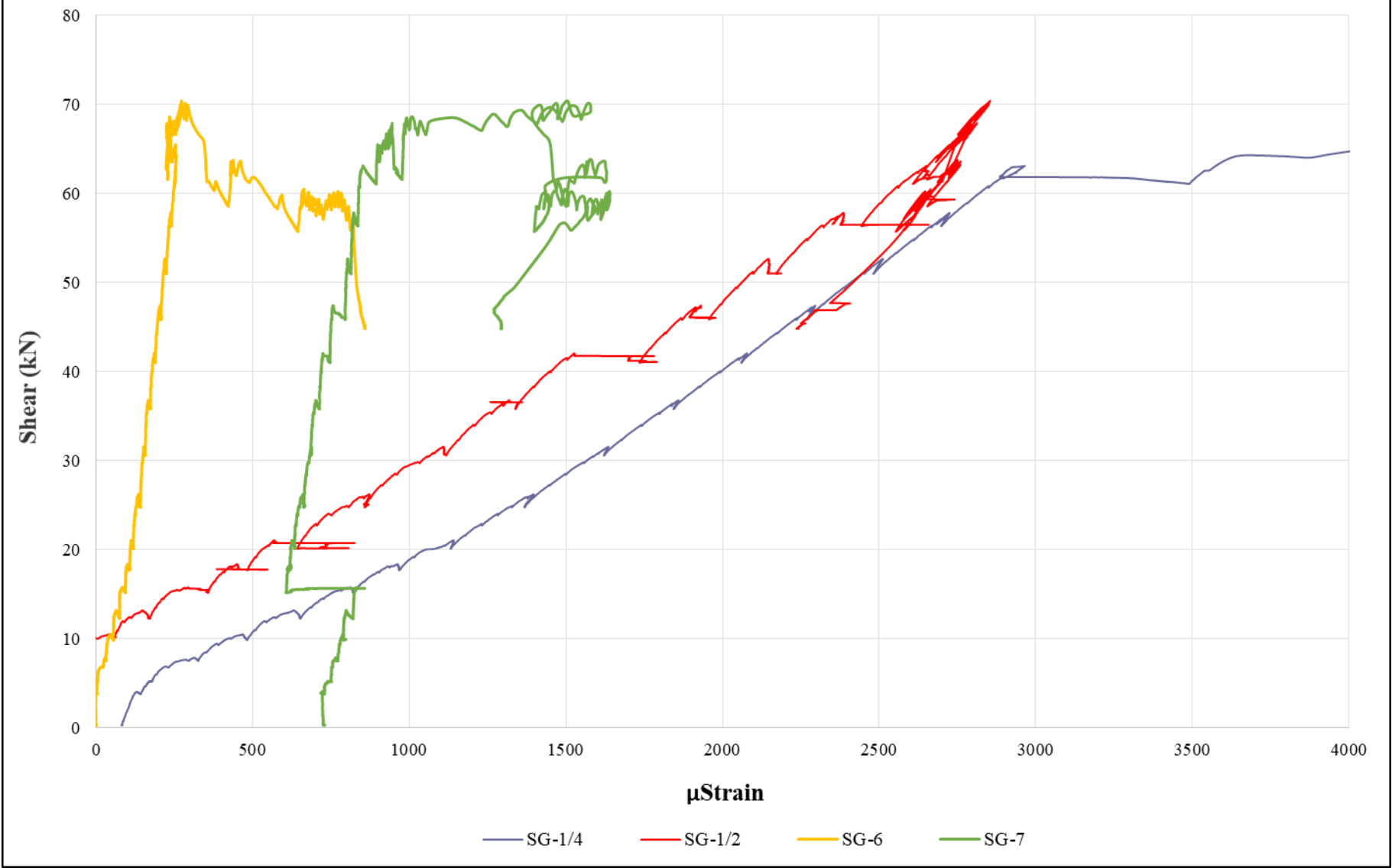

### 100-FL Beam Strain Gauges

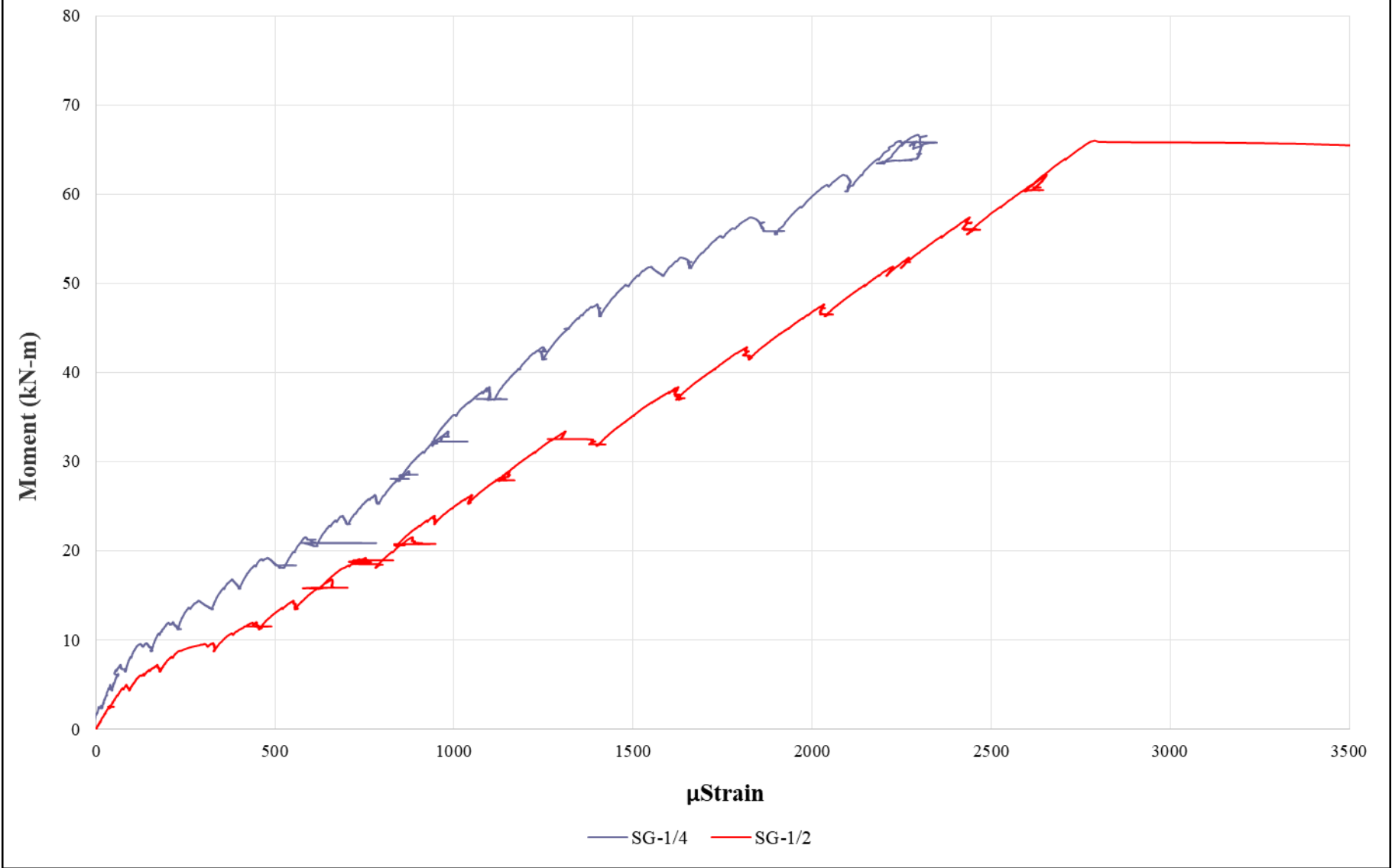

### 100-S Beam Strain Gauges

